

TRADE OF  
**Industrial Insulation**

PHASE 2

---

**Module 1**

---

**Sheet Metal and Insulation Fundamentals**

UNIT: 10

**Pipe Insulation (Hot & Cold)  
Material Selection & Application**

*Produced by*

**S O L A S**

**An tSeirbhís Oideachais Leanúnaigh agus Scileanna  
Further Education and Training Authority**

*In cooperation with subject matter expert:*

**Michael Kelly**

**© SOLAS 2014**

## Table of Contents

Introduction.....	1
Unit Objective .....	2
1.0 Insulation.....	3
1.1 Temperature Ranges.....	3
1.2 Insulation Types.....	4
1.3 Insulation Forms.....	4
1.4 Insulating Materials-Hot and Cold Applications.....	4
2.0 Health and Safety.....	7
2.1 Hazards.....	7
2.2 Safety Precautions.....	7
3.0 Understanding a Typical Works Specification .....	9
3.1 Scope.....	9
3.2 General Conditions.....	9
3.3 Material Specification .....	10
3.4 Application Specification.....	10
4.0 Application of Insulation Material to Pipe Work .....	11
4.1 Installing Insulation on New Pipe Work.....	11
4.2 The Slip-On Method .....	12
4.3 The Snap-On Method .....	13
4.4 Installing ArmaTuff.....	13
4.5 Vapour Barrier.....	15
Summary.....	16

# Introduction

There are many insulating products on the market today which cover all temperature ranges and all conceivable installation situations. Although there are too many products to mention, it is important that the apprentice has a good understanding of some of the different products available and their applications. The apprentice must have a grasp of the correct method of insulation construction and be able to understand a works specification.

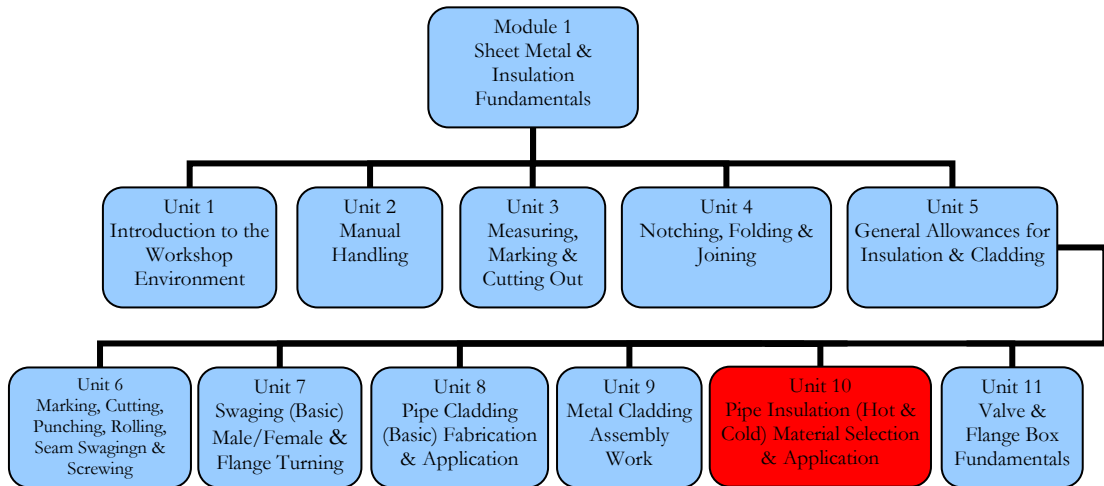

## Unit Objective

By the end of this unit **each apprentice** will be able to:

- Identify Insulation Materials.
- Identify the hazards associated with insulation materials.
- Understand a typical works specification.
- Apply a section of insulating material to pipe work.
- Apply sealant to hot and cold work insulation.
- Apply a vapour barrier to cold work insulation.

# 1.0 Insulation

## Key Learning Points

- Identification of insulating materials.
- Selection criteria of materials for hot and cold work.
- Insulation requirements for hot and cold work materials.

Insulations are defined as those materials or combinations of materials which retard the flow of heat energy by performing one or more of the following functions:

- Conserve energy by reducing heat loss or gain.
- Control surface temperatures for personnel protection and comfort.
- Facilitate temperature control of process.
- Prevent vapour flow and water condensation on cold surfaces.
- Increase operating efficiency of heating/ventilating/cooling, plumbing, steam, process and power systems found in commercial and industrial installations.
- Prevent or reduce damage to equipment from exposure to fire or corrosive atmospheres.
- Assist mechanical systems in meeting criteria in food and cosmetic plants.
- Reduce emissions of pollutants to the atmosphere.

## 1.1 Temperature Ranges

The temperature range, within which the term "thermal insulation" will apply, is from  $-75^{\circ}\text{C}$  to  $815^{\circ}\text{C}$ . All applications below  $-75^{\circ}\text{C}$  are termed "cryogenic", and those above  $815^{\circ}\text{C}$  are termed "refractory".

Thermal insulation is further divided into three general application temperature ranges as follows:

### A. Low Temperature Thermal Insulation

- (1).  $5^{\circ}\text{C}$  through  $0^{\circ}\text{C}$  - i.e. Cold or chilled water.
- (2).  $0^{\circ}\text{C}$  through  $-40^{\circ}\text{C}$  - i.e. Refrigeration or glycol.
- (3).  $-40^{\circ}\text{C}$  through  $-75^{\circ}\text{C}$  - i.e. Refrigeration or brine.
- (4).  $-75^{\circ}\text{C}$  through  $-275^{\circ}\text{C}$  (absolute zero) - i.e. Cryogenic.

### B. Intermediate Temperature Thermal Insulation

- (1).  $16^{\circ}\text{C}$  through  $100^{\circ}\text{C}$  - i.e. Hot water and steam condensate.
- (2).  $100^{\circ}\text{C}$  through  $315^{\circ}\text{C}$  - i.e. Steam, high temperature hot water.

## C. High Temperature Thermal Insulation

- (1). 315°C through 815°C - i.e. Turbines, breechings, stacks, exhausts, incinerators.

### 1.2 Insulation Types

Insulation materials are generally divided into three main types:

- **Fibrous Insulation** - composed of small diameter fibres which finely divide the air space. The fibres may be perpendicular or parallel to the surface being insulated, and they may or may not be bonded together. Silica, rock wool, slag wool and alumina silica fibres are used. The most widely used insulations of this type are glass fibre and mineral wool. Glass fibre and mineral wool products usually have their fibres bonded together with organic binders that supply the limited structural integrity of the products.
- **Cellular Insulation** - composed of small individual cells separated from each other. The cellular material may be glass or foamed plastic such as cellular glass, phenolic foam or nitrile rubber.
- **Granular Insulation** - composed of small nodules which may contain voids or hollow spaces. It is not considered a true cellular material since gas can be transferred between the individual spaces. This type may be produced as a loose or pourable material, or combined with a binder and fibres or undergo a chemical reaction to make a rigid insulation. Examples of these insulations are calcium silicate and vermiculite.

### 1.3 Insulation Forms

Insulations are produced in a variety of forms suitable for specific functions and applications. The combined form and type of insulation determine its proper method of installation. The forms most widely used are:

- Rigid boards, blocks, sheets, and pre-formed shapes such as pipe insulation, curved segments, lagging etc. Cellular, granular, and fibrous insulations are produced in these forms.
- Flexible sheets and pre-formed shapes. Cellular and fibrous insulations are produced in these forms.
- Flexible blankets. Fibrous insulations are produced in flexible blankets.
- Cements (insulating and finishing). Produced from fibrous and granular insulations and cement, they may be of the hydraulic setting or air drying type.
- Foams. Poured or froth foam used to fill irregular areas and voids. Spray used for flat surfaces.

### 1.4 Insulating Materials-Hot and Cold Applications

The following is a general inventory of the characteristics and properties of major insulation materials used in commercial and industrial installations.

## Mineral Fibre

Glass: Available as flexible blanket, rigid board, pipe covering and other pre-molded shapes. Service temperature range is up to 535°C.

Rock and Slag: Rock and slag fibres are bonded together with a heat resistant binder to produce mineral fibre or wool. Upper temperature limit can reach 1035°C.

## Cellular

Available in board and block form capable of being fabricated into pipe covering and various shapes. Service temperature range is -260°C to 200°C and to 650°C in composite systems. Good structural strength, poor impact resistance. Material is non-combustible, non-absorptive and resistant to many chemicals.

## Calcium Silicate

Calcium Silicate is a granular insulation made of lime and silica, reinforced with organic and inorganic fibres and moulded into rigid forms. Service temperature range covered is 35°C to 815°C. Flexural and compressive strength is good. Calcium silicate is water absorbent. However, it can be dried out without deterioration. The material is non-combustible and used primarily on hot piping and surfaces. Finishing material is applied on site.

## Expanded Silica or Perlite

Perlite is made from an inert siliceous volcanic rock combined with water. The rock is expanded by heating to above 535°C causing the water to vaporize and the rock volume to expand. This creates a cellular structure of minute air cells surrounded by vitrified product. Added binders resist moisture penetration and inorganic fibres reinforce the structure. The material has low shrinkage and high resistance to substrate corrosion. Perlite is non-combustible and operates in the intermediate and high temperature ranges. The product is available in rigid pre-formed shapes and blocks.

## Elastomeric Foam

Foamed resins combined with elastomers produce a flexible cellular material. Available in pre-formed shapes and sheets, elastomeric insulations possess good cutting characteristics and low water and vapour permeability. The upper temperature limit is at 105°C. Elastomeric insulation is cost efficient for low temperature applications with no cladding necessary. Resiliency is high. Consideration should be made for fire retardancy of the material.

## Foamed Plastic

Insulations produced from foaming plastic resins create predominately closed cellular rigid materials. "K" values or lambda values decline after initial use as the gas trapped within the cellular structure is eventually replaced by air. Check manufacturers' data. Foamed plastics are light weight with excellent cutting characteristics. The chemical content varies with each manufacturer. Available in pre-formed shapes and boards, foamed plastics are generally used in the lower intermediate temperature range. Consideration should be made for fire retardancy of the material.



### **Refractory Fibre**

Refractory fibre insulations are mineral or ceramic fibres, including alumina and silica, bonded with extremely high temperature inorganic binders, the mechanical interlocking of fibres eliminates the need for any binder. The material is manufactured in blanket or rigid form. Thermal shock resistance is high. Temperature limits reach 1750 °C. The material is non-combustible.

### **Phenolic Foam**

Rigid closed cell foamed insulation manufactured from phenolic resin.

### **Insulating Cement**

Insulating and finishing cements are a mixture of various insulating fibres and binders with water and cement, to form a soft plastic mass for application on irregular surfaces. Insulation values are moderate. Cements may be applied to high temperature surfaces. Finishing cements or one-coat cements are used in the lower intermediate range and as a finish to other insulation applications. Check each manufacturer for shrinkage and adhesion properties.

## 2.0 Health and Safety

### Key Learning Points

- Health hazard identification.
- Adaptability to new situations, problem analysis and problem solving.
- Professional attitude towards finish and quality.

### 2.1 Hazards

All industrial and residential insulating products have some known negative health effects. Apprentices and tradespersons who are exposed on a daily basis to different insulating products should ensure that they fully understand the health risks associated with each product, and take the appropriate health and safety precautions when using these products. Some common health effects would be, but not limited to, the following:

- Skin irritation due to contact with small fibres in the insulation.
- Lung and respiratory problems due to inhaling fibres.
- Toxic fumes given off from burning.
- Dust particles.

Every apprentice will be subject to different job situations every day. Risks associated with one job site may be completely different to potential risks on another job. It is important that the apprentice is able to adapt to new situations according to each job. Every new job will in turn require problem analysis and problem solving. The apprentice should develop a professional attitude towards his/her work from the start including health and safety, working with people, quality and finish and taking pride in their work.

### 2.2 Safety Precautions

The following safety precautions should be taken when handling different insulating materials:

1. Protective clothing and gloves should be worn to protect the skin.
2. A good quality dust mask should be worn to protect the lungs.
3. Always work in a well ventilated area. Unless proper procedures and control measures have been implemented, dust collection systems should be used in manufacturing and fabrication settings where appropriate and feasible.
4. Caution should be taken using knives or saws for cutting insulation.
5. Keep materials in their packaging as long as practical and possible.
6. Keep work areas clean and free from scrap materials.

7. Avoid unnecessary handling of waste insulation materials by placing them in waste disposal containers or bags, and keep equipment as close to work areas as possible to prevent the release of fibres.
8. Tools that generate the least amount of dust should be used. If power tools are to be used, they should be equipped with dust collecting systems attached.
9. Always refer to the manufacturer's instructions and safety data sheets for additional information.

## 3.0 Understanding a Typical Works Specification

### Key Learning Points

- Works specification interpretation and analysis.
- Use of technical data and information gathering.

A well written specification must convey to the installing contractor or personnel, clearly and without exception, the intent of the specification. It must provide the information necessary for the installation to proceed but does not have to state what is not required. It must list only the things required for the proper installation and supply of the insulation system as defined by the scope. Lastly, a well-written specification will serve to establish proven standard methods of construction.

Regardless of how thorough the specification is written, however, it will not always be practical to cover every conceivable detail that may arise. As is the case in all phases of construction, good common sense and judgement must be exercised in conjunction with any specification. Alternative designs will always be available and can be submitted as options.

An works specification should be broken down into four different sections: scope, general conditions, material specifications and application specification.

### 3.1 Scope

This section should set the boundaries of the work within the specification. It can be relatively short and can be done by a written description, key arrangement drawing or quantitative take-off. An example of a descriptive scope could be written as the following:

*These specifications cover the insulation material and application for the surfaces outlined on the following pages and in accordance with the relative drawings.*

Providing a quantitative take-off in the specification is the best way to define work scope. A take-off detailing area by area with the specific materials and attachments required will eliminate any questions such as “What materials are required to be used in a specific area” and “What exactly are the scope limitations”.

### 3.2 General Conditions

This section should clearly specify what the job conditions are relating to storage, warehousing and responsibilities. It should also tie the specifications to the actual contract agreement that may exist between the customer and the installing contractor. Some examples are:

- These specifications are to provide for the economic application of the insulation material.
- Questions concerning application methods as specified in this contract are to be resolved with the company prior to signing of the contract.
- The contractor, upon signing this contract, covenants and agrees to the requirements of this contract.
- All materials required for the proper support and fastening of the insulation shall be installed by the insulating contractor and be of such quality to be suitable for the purpose intended.
- Where application drawings differ from actual contract drawings, written specifications, key arrangement drawings and section drawings, the insulation contractor will follow the latter.

### 3.3 Material Specification

This section must clearly specify what materials can be used. A material can be specified by what it is made of and the manner in which the material was manufactured (e.g. a cellular glass product). A material can be specified by a manufacturer or trade name. Lastly, it can be specified by its generic classification and its properties (e.g. mineral wool slab to BS 3958-5, 200 kg/m<sup>3</sup> normal bulk density).

### 3.4 Application Specification

This section must state or clearly show by a written specification and/or by application drawings the minimum requirements and accepted standards for applying the insulation. The information will be used as a guide to apply the insulation to the scope of the work shown on the actual contract design drawings. An example of a well written specification defining application is:

Install 50mm thick mineral wool blanket insulation wired to the secondary super heater tube sections and headers. Where the tube or section spacing is greater than 225mm, an inner support shall be utilised. Refer to material specifications for approved insulation materials, lacing wire and insulation support. All blanket edges must be sewn together.

## 4.0 Application of Insulation Material to Pipe Work

### Key Learning Points

- Measuring, cutting and shaping of insulation material.
- Application of cut insulation to given pipe work.
- Pipe insulation securing methods and devices.
- Function of vapour barriers. Sealant and vapour barrier selection and application.

The quality of an insulating product depends largely on the installation, and the tradesperson's knowledge of the product and the limitations of its use. For the purposes of this unit we will focus on a number of Armaflex insulating products and their applications. The following precautions should be followed when installing any type of insulation:

1. Insulation products should only be applied to pipe work which is clean, dry and unheated.
2. Do not compress Armaflex at joists, studs, columns, ducts etc. This is important because any insulation loses some of its insulation value if it is compressed. On cold pipes condensation may occur where the insulation is compressed.
3. Space should be allowed around pipe work to help air circulation. Air movement is an extra safeguard against condensation on cold pipes especially in hot, humid weather.
4. Never stretch Armaflex insulation. Always use the proper size of insulation for the job. Do not stretch it over the pipe. Use pieces of Armaflex that are at least as long as the section of pipe to be insulated. Butt-end joints can be made without stretching the lengths of insulation.
5. Proper sealing of all pipe insulation is important to minimise heat loss and control condensation. On cold lines, open pipe insulation joints may allow the formation of condensate drip or contribute to possible pipe or tubing corrosion. All insulation joints should be sealed as shown in the insulation instructions.

### 4.1 Installing Insulation on New Pipe Work

1. Before the fitting is soldered, push the Armaflex insulation back on the tubing, and hold in place with clamps applied to the tubing. To avoid damage to the insulation, temperatures must not exceed the upper use limit of 105° C. Remove the clamps after the fitting has been soldered and cooled.

2. Fabricate fitting cover from properly mitred pieces. After adhesive has dried, carefully slit the fitting cover.
3. Snap the fitting cover in place over the fitting.
4. After the line has been tested, apply brush coating of 520 or 520 BLV adhesive to all joint surfaces.
5. Allow adhesive to dry until dry to the touch but tacky under slight pressure before joining surfaces.

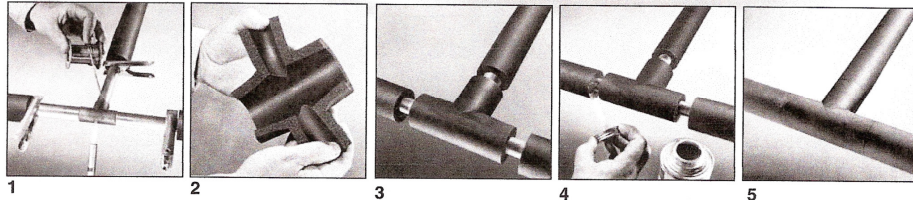

6. Armaflex is slipped over the line and butted tightly against the fitting.
7. Fabricate fitting covers from mitre-cut pieces of Armaflex. Slit the completed cover, and snap it into position over the fitting.
8. After the line has been tested complete the installation by cementing the slit joint of the fitting cover with 520 or 520 BLV adhesive. When the adhesive has become tacky to the touch, press the joint firmly together. Also cement the 25mm overlap with the adhesive by forcing the brush between the two surfaces.

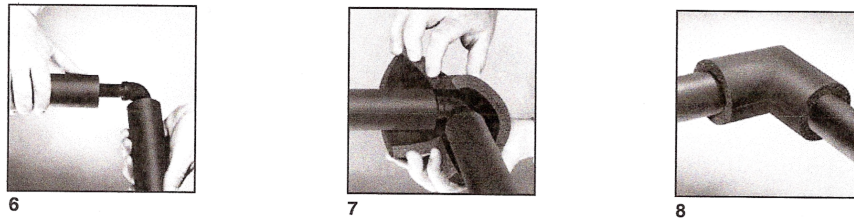

9. Insulate screwed fittings with sleeve-type fittings made from Armaflex pipe insulation having an inside diameter large enough to overlap the insulation on the straight piping next to the fitting by at least 25mm.

## 4.2 The Slip-On Method

The slip-on method is used when you can insulate new piping before it goes up or while it is being connected.

1. Slip the pipe insulation over the pipe or copper tubing. The inside surface of Armaflex insulation is coated with a powder lubricant, making it easy to slip the insulation over the pipe. It is important to note that the powdered lubricant should not be allowed to enter the ends of the pipe work and it is advisable to cover the ends of the pipe before applying the insulation.
2. Since the insulation is flexible it will follow the bends in the tubing and can be slipped right over bent tubing, 45° sweat bends and couplings.

3. At 90° sweat bends, cut the insulation, and butt against each side of the fitting. A fitting cover will be installed later over these fittings.
4. Use a length of Armaflex as long as or slightly longer than the section of piping to be covered. Never stretch the Armaflex.
5. Apply brush coating of 520 or 520 BLV adhesive to both butt ends to be joined, since this is a contact type adhesive.
6. Allow the adhesive to set until dry to the touch but tacky under slight pressure before joining both surfaces.

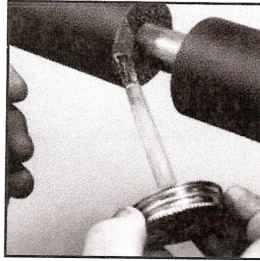

### 4.3 The Snap-On Method

The snap-on method is used when pipe or copper tubing is insulated after it has been installed.

1. With unslit tubular Armaflex pipe insulation, use a sharp knife to slit the insulation lengthwise on one side. For oval tubes, slit on the flat side only.
2. Snap the insulation over the pipe.
3. Brush coat both slit surfaces with Armaflex 520 or 520 BLV adhesive alternating sides for even drying times. Push the insulation down over the pipe to hold the adhesive coated surfaces apart while the adhesive dries.
4. Allow the adhesive to dry until dry to the touch but tacky under pressure before joining the surfaces. Test with the back of your fingernails.
5. If the insulation should become stuck to the pipe after applying the insulation, break the insulation loose by running a finger down the pipe.
6. When the insulation has air-dried, apply a moderate pressure to the entire joint to assure a vapour tight bond.
7. In double layer work when using the snap-on method, apply Armaflex insulation with the side and end joints staggered where possible.

*Refer to module 4 – unit 10 – section 2 – cutting and application.*

### 4.4 Installing ArmaTuff

Flexible ArmaTuff Plus, ArmaTuff White or ArmaTuff Silver can be used on all exterior applications. They are practical also for use on exterior ducts, tanks, vessels, large pipes and fittings. The material provides a durable tough and maintenance-free surface. The material is resistant to UV, ozone, acid rain and most industrial pollutants, and no painting is required.



The recommended temperature range for ArmaTuff is -70°F to 180°F. The closed cell structure of the insulation effectively retards the flow of water vapour, and it is considered a low transmittance vapour retarder. ArmaTuff does not require additional vapour retarder. The white surface reflects heat to reduce energy load.

ArmaTuff is installed using 520 or 520BLV adhesive or with pre-applied pressure sensitive adhesive (PSA). For application to large, flat or curved metal surfaces such as ducts, vessels, very large pipes or tanks, full Armaflex 520 or 520 BLV adhesive coverage or product with PSA is used. The seams must be installed in compression and sealed with Armaflex adhesive. Cover the seam with 100mm and exposed edges with 100mm-150mm ArmaTuff seal tape. Armaflex 520 or 520Blv adhesive is a contact adhesive and must be applied to both surfaces, allowed to get tacky, and the surfaces are joined with pressure.

### Applying Non-Self Adhering ArmaTuff Sheets



1. Always prepare surface by cleaning with denatured alcohol.



4. Position carefully and apply ArmaTuff. Contact adhesive bonds instantly.

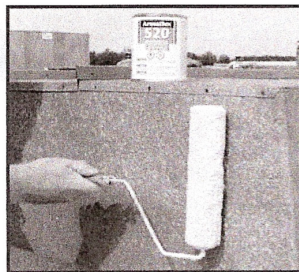

2. Insulate sides first. Apply thin, uniform coat of Armaflex 520 or 520 BLV Adhesive.

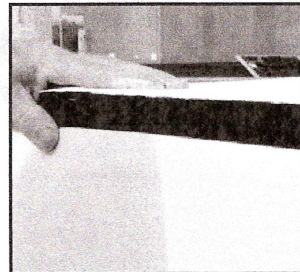

5. Apply ArmaTuff to top surface, overlapping the side pieces.



3. Roll thin coat of 520 or 520 BLV Adhesive to insulation.

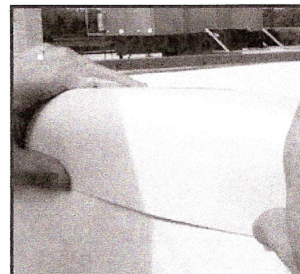

6. Seal and protect exposed edges and seams with ArmaTuff Seal Tape.

## 4.5 Vapour Barrier

Vapour barriers are designed to retard the passage of moisture vapour from the atmosphere to the insulated surface. Joints and overlaps must be sealed with a vapour tight adhesive or sealer, free of pin holes or cracks. Vapour-barriers take three forms:

- Rigid jacketing - plastic fabricated to the exact dimensions and sealed vapour tight.
- Membrane jacketing - laminated foils and treated or coated products which are field or factory applied to the insulation material. (Additional sealing beyond the factory seal may be necessary depending on temperature/humidity conditions of the installation.)
- Mastic applications - solvent types which provide a seamless coating but require time to dry.

### PIPING (0°C THROUGH -40°C)

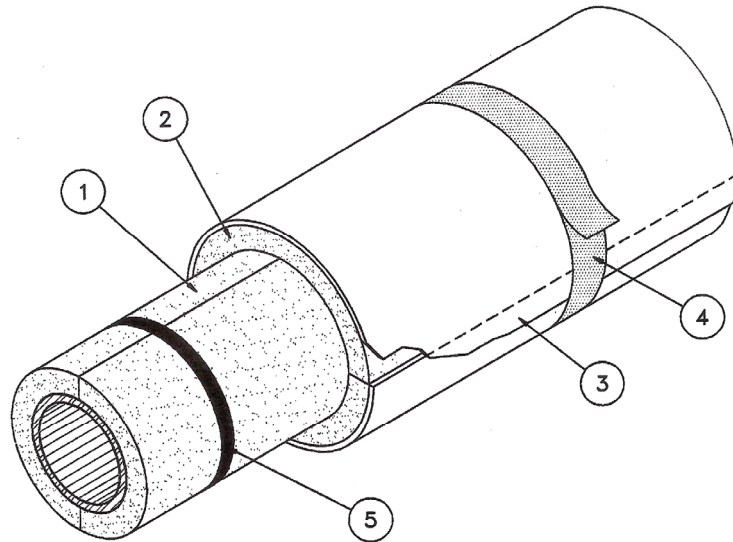

- 1 INSULATION INNER LAYER
- 2 INSULATION OUTER LAYER WITH JOINTS STAGGERED
- 3 LONGITUDINAL LAP ON VAPOUR RETARDER SEALED
- 4 BUTT JOINT VAPOUR RETARDER SEALED
- 5 BANDING, WIRE OR TAPE AS REQUIRED

## Summary

Insulation materials are used to retard the flow of heat energy by reducing heat loss or gain from pipe work, ductwork, tanks and vessels. Insulation products are available in many shapes and forms from rolls, slabs and pipe sections to insulating and finishing cements. They are used on mechanical services ranging in temperature from cryogenic to refractory. Insulation products can assist mechanical systems to operate within environmental criteria and also reduce emissions of pollutants to the atmosphere.

S O L A S

An tSeirbhís Oideachais Leanúnaigh agus Scileanna  
Further Education and Training Authority

*Castleforbes House  
Castleforbes Road  
Dublin 1*