



PROCESS  
INDUSTRY  
PRACTICES

COMPLETE REVISION

*P&ID Sample*

**PIP PIC001**  
**Piping and Instrumentation Diagram**  
**Documentation Criteria**

---

Sample - Not for Commercial Use

## PURPOSE AND USE OF PROCESS INDUSTRY PRACTICES

In an effort to minimize the cost of process industry facilities, this Practice has been prepared from the technical requirements in the existing standards of major industrial users, contractors, or standards organizations. By harmonizing these technical requirements into a single set of Practices, administrative, application, and engineering costs to both the purchaser and the manufacturer should be reduced. While this Practice is expected to incorporate the majority of requirements of most users, individual applications may involve requirements that will be appended to and take precedence over this Practice. Determinations concerning fitness for purpose and particular matters or application of the Practice to particular project or engineering situations should not be made solely on information contained in these materials. The use of trade names from time to time should not be viewed as an expression of preference but rather recognized as normal usage in the trade. Other brands having the same specifications are equally correct and may be substituted for those named. All Practices or guidelines are intended to be consistent with applicable laws and regulations including OSHA requirements. To the extent these Practices or guidelines should conflict with OSHA or other applicable laws or regulations, such laws or regulations must be followed. Consult an appropriate professional before applying or acting on any material contained in or suggested by the Practice.

This Practice is subject to revision at any time.

© Process Industry Practices (PIP), Construction Industry Institute, The University of Texas at Austin, 3925 West Braker Lane (R4500), Austin, Texas 78759. PIP Member Companies and Subscribers may copy this Practice for their internal use. Changes or modifications of any kind are not permitted within any PIP Practice without the express written authorization of PIP. Authorized Users may attach addenda or overlays to clearly indicate modifications or exceptions to specific sections of PIP Practices. Authorized Users may provide their clients, suppliers and contractors with copies of the Practice solely for Authorized Users' purposes. These purposes include but are not limited to the procurement process (e.g., as attachments to requests for quotation/ purchase orders or requests for proposals/contracts) and preparation and issue of design engineering deliverables for use on a specific project by Authorized User's client. PIP's copyright notices must be clearly indicated and unequivocally incorporated in documents where an Authorized User desires to provide any third party with copies of the Practice.

**Note:** *PIP PIC001, Piping and Instrumentation Diagram Documentation Criteria*, incorporates symbols previously published in standards owned and copyrighted by The Instrumentation, Systems, and Automation Society (ISA). These are printed with agreement from ISA.

### **PUBLISHING HISTORY**

November 1998      Issued  
April 2008          Complete Revision

Not printed with State funds



# PIP PIC001 Piping and Instrumentation Diagram Documentation Criteria

## Table of Contents

**1. Introduction .....2**

1.1 Purpose .....2

1.2 Scope .....2

**2. References .....2**

2.1 Process Industry Practices .....3

2.2 Industry Codes and Standards .....3

2.3 Government Regulations .....3

**3. Definitions .....3**

**4. Requirements .....6**

4.1 General .....6

4.2 Format .....6

4.3 Equipment .....11

4.4 Piping .....17

4.5 Instrumentation and Controls .....20

## Appendixes

Appendix A – Detailed Equipment Labels  
PIC001-A-001-1 – Appendix A – Suggested  
Detailed Equipment Labels  
PIC001-A-001-2 – Appendix A – Suggested  
Detailed Equipment Labels

Appendix B – Legend Sheets  
PIC001-B-001 – Appendix B-1 – Typical  
Piping Legend Sheet  
PIC001-B-002 – Appendix B-2 – Typical  
Instrumentation Legend Sheet

PIC001-B-003-1 – Appendix B-3 – Driven  
Equipment Legend Sheet  
PIC001-B-003-2 – Appendix B-3 – Heat  
Transfer Equipment Legend Sheet  
PIC001-B-003-3 – Appendix B-3 – Vessels &  
Tanks Legend Sheet  
PIC001-B-003-4 – Appendix B-3 – Solids &  
Material Handling Equipment Legend Sheet  
PIC001-B-003-5 – Appendix B-3 – Fire &  
Safety Equipment Legend Sheet  
PIC001-B-004 – Appendix B-4 – Typical  
Details with Implied Components

Appendix C – Example P&IDs  
PIC001-C-001 – Appendix C-1 – Example  
Process P&ID 1  
PIC001-C-002 – Appendix C-2 – Example  
Process P&ID 2  
PIC001-C-003 – Appendix C-3 – Example  
Utility P&ID

Appendix D – P&IDs for the Hygienic Processing  
Industries  
PIC001-DB-001 – Appendix DB-1 – Hygienic  
Process Piping Legend Sheet  
PIC001-DB-002 – Appendix DB-3 – Hygienic  
Process Equipment Legend Sheet  
PIC001-DC-001 – Appendix DC-1 – Hygienic  
Process Example Process P&ID 1  
PIC001-DC-002 – Appendix DC-2 – Hygienic  
Process Example Process P&ID 2  
PIC001-DC-003 – Appendix DC-3 – Hygienic  
Process Example Process P&ID 3

## 1. Introduction

---

### 1.1 Purpose

This Practice provides requirements for designers preparing Piping and Instrumentation Diagrams (P&IDs).

### 1.2 Scope

This Practice describes the requirements for P&ID format and content. The Practice is independent of time in a facility life cycle and encompasses design, construction, operations, and maintenance.

This Practice covers the generation of new P&IDs and does not apply to the revision of existing P&IDs. This Practice also applies to P&IDs provided by packaged equipment vendors.

This Practice applies to all diagrams that fit the definition of a P&ID in Section 3.

The requirements provided in this Practice can be applied to any CAD system used for developing the P&IDs and are not vendor, hardware, or software specific.

The requirements provided in this Practice provide a balance between showing all data on P&IDs and making P&IDs legible and easy to read. While this Practice is expected to incorporate the majority of requirements of most users, individual applications may involve requirements that will be appended to and take precedence over this Practice. Determinations concerning fitness for purpose and particular matters or application of the Practice to particular project or engineering situations should not be made solely on information contained in these materials.

The example P&IDs included in the Appendixes of this Practice are not intended to recommend specific design details or requirements. Example P&IDs are included to provide an illustration of how the elements of this Practice are combined into a P&ID.

Electronic native files for the text, symbols, and cover sheets are available to PIP Member Companies for input to members' CAD systems. Development of project-specific cover sheets is recommended using the PIP native files as a starting point. Additions and/or deletions are allowed to meet requirements. Cover sheet borders and title blocks can be altered.

## 2. References

---

Applicable parts of the following Practices, industry codes and standards, and references shall be considered an integral part of this Practice. The edition in effect on the date of start of P&ID development shall be used, except as otherwise noted. Short titles are used herein where appropriate.

### 2.1 Process Industry Practices (PIP)

- PIP INEG1000 – *Insulation Design and Type Codes*
- PIP PCCIP001 – *Instrument Piping and Tubing Systems Criteria*
- PIP PCSIP001 – *Instrument Piping and Tubing Systems Specifications*

- PIP PNE00001 – *Design of ASME B31.3 Metallic Piping Systems*
- PIP PNSM0001 – *Piping Line Class Designator System*

## 2.2 Industry Codes and Standards

- American National Standards Institute (ANSI)
  - ANSI/FCI 70-2-2003 – *Control Valve Seat Leakage*
- American Society of Mechanical Engineers (ASME)
  - *ASME Boiler and Pressure Vessel Code*  
Section VIII – *Pressure Vessels*
- The Instrumentation, Systems, and Automation Society (ISA)
  - ISA 5.1 – *Instrumentation Symbols and Identification*
  - ISA 5.2 – *Binary Logic Diagrams for Process Operations*
  - ISA 5.3 – *Graphic Symbols for Distributed Control / Shared Display Instrumentation, Logic and Computer Systems*
  - ISA 84.01 – *Application of Safety Instrumented Systems for the Process Industries*
- Tubular Exchanger Manufacturers Association (TEMA)
  - TEMA Standards

## 2.3 Government Regulations

- Occupational Safety and Health Administration (OSHA)
  - OSHA 29 CFR 1910.119 – *Occupational Safety and Health Standards, Process Safety Management of Highly Hazardous Chemicals*

## 3. Definitions

---

For the purposes of this Practice, the following definitions apply:

*accessible*: Term applied to a device or function that can be used or seen by an operator for the purpose of performing control actions (e.g., set point changes, auto-manual transfer, or on/off actions) (Reference ISA 5.1)

*automated valve*: Any valve with a locally or remotely controlled actuator. Examples are throttling control valves and on/off block valves. Actuators are typically air-operated (diaphragm or piston), electric or hydraulic, some with a spring-return function. Manually-operated valves are sometimes tagged as automated valves (e.g., if a manual valve is fitted with position switches).

*auxiliary P&ID*: Used to show details to unclutter other P&IDs (e.g., lube oil system, sample systems, instrument details)

*Basic Process Control System (BPCS)*: Control equipment and system installed to regulate normal production functions. It may contain combinations of single-loop pneumatic controllers, single-loop electronic controllers, Programmable Logic Controllers (PLCs), and Distributed Control Systems (DCSs). The BPCS is required to operate the process. Examples of control

functions included in the BPCS are cascade control, override control, and pump start/stop. Also known as Basic Regulatory Controls. (See also HLCS and SIS)

*bubble*: Circular symbol used to denote and identify the purpose of an instrument or function. The bubble usually contains a tag number. (Synonym for balloon) (Reference *ISA 5.1*)

*design pressure*: Pressure used in the design of a vessel component together with the coincident design metal temperature for determining the minimum permissible thickness or physical characteristics of the different zones of the vessel. (Reference *ASME Boiler Pressure Vessel Code*, Section VIII, Division 1, Appendix 3)

*fail closed (FC)*: Characteristic of an automated valve that causes the valve to close as a result of specific malfunctions, including loss of signal or motive power. (Reference *ISA 5.1*)

*fail indeterminate (FI)*: Characteristic of an automated valve that causes the valve to move to an unknown position as a result of specific malfunctions, including loss of signal or motive power. Some automated valves will not stay at the last position upon failure and instead move with the process differential pressure. Additional equipment may be needed to meet the definition of FC, FO, or FL. (Reference *ISA 5.1*)

*fail locked (FL) last position*: Characteristic of an automated valve that causes the valve to remain in the last (locked) position as a result of specific malfunctions, including loss of signal or motive power. Automated valves may fail indeterminately without additional equipment. (Reference *ISA 5.1*)

*fail open (FO)*: Characteristic of an automated valve that causes the valve to open as a result of specific malfunctions, including loss of signal or motive power. (Reference *ISA 5.1*)

*hand switch (HS)*: Any operator-manipulated discrete control device, including hardwired panel switches and software points.

*heat exchanger type*: Type designation shall be shell and tube, plate and frame, spiral, etc. For shell and tube exchangers, use the three-letter designation describing stationary head, shell, and rear end or head, in that order, in accordance with TEMA.

*Higher Level Control System (HLCS)*: Provides sophistication above that of the BPCS. The HLCS is not necessary to operate the process. HLCS functions are typically based in process computers or higher level DCS hardware that interacts with the process by manipulating set points in the BPCS. Examples of control functions in the HLCS are statistical process control and model predictive control. (See also BPCS and SIS)

*interlock*: System that, in response to a predetermined condition, initiates a predefined action. Typically comprised of binary (on/off) signals and logic used for process control, sequencing, or protective interruption of normal process control functions. Protective interlocks are typically further defined as being either safety-related or commercial-related (asset or production protection).

*isolation valve*: A valve used for isolation of process equipment while performing activities such as purging, de-pressuring or de-inventorying. This valve is also commonly referred to as the primary block valve.

*line class*: Section of the Piping Material Specifications that provides a listing of piping components for specific design conditions.

*logic solver*: Control equipment that performs the logic function. It can be either hardwired (e.g., relays) or Programmable Electronic Systems (e.g., DCS-based or PLC-based, including dual-redundant or triple-redundant microprocessors).

*packaged equipment*: One or more pieces of equipment furnished by a vendor with supportive devices and components to perform a specific operation as a unit

*Piping and Instrumentation Diagram (P&ID)*: Detailed graphical representation of a process including the hardware and software (i.e., piping, equipment, and instrumentation) necessary to design, construct and operate the facility. Common synonyms for P&IDs include Engineering Flow Diagrams (EFDs), Utility Flow Diagrams (UFDs), and Mechanical Flow Diagrams (MFDs)

*Programmable Electronic System (PES)*: Logic performed by programmable or configurable devices (Reference ISA 84.01)

*root valve*: First valve or valves between the process and an auxiliary device (e.g., an instrument) that contacts the process and is used to isolate the device from the process. This valve is typically a line class valve used for shut-off and isolation.

*Safety Integrity Level (SIL)*: One of four possible discrete integrity levels (SIL 1, SIL 2, SIL 3, and SIL 4) of Safety Instrumented Systems. SILs are defined in terms of Probability of Failure on Demand (PFD). (Reference ISA 84.01)

*Safety Instrumented Systems (SIS)*: Systems composed of sensors, logic solvers, and final control elements for the purpose of taking the process to a safe state if predetermined conditions are violated. Other terms commonly used include Emergency Shutdown System (ESD or ESS), Safety Shutdown System (SSD), and Safety Interlock System (SIS). (Reference ISA S84.01) (See also BPCS and HLCS)

*skirt*: Cylindrical supporting structure, welded to the bottom of a vertical vessel and extended to the base support

*tagged*: For the purposes of labeling instrumentation and control components, a hardware device or a software point that is identified with an ISA style tag number

*Tight Shut-Off (TSO)*: Tight Shut-Off is defined in this Practice as ANSI Class V or ANSI Class VI in accordance with ANSI/FCI 70-2

*trim*: Item attached to equipment as an integral component, identified as part of the equipment that is exposed to the process, and having a function local to the equipment being served. Examples are vent and drain valves, instrument bridles, blind flanges, plugs, or other miscellaneous items associated with a piece of equipment. Typically, trim is purchased independently from the equipment.

## **4. Requirements**

---

### **4.1 General**

- 4.1.1 Most details available from other types of documentation (e.g., instrument loop diagrams and vessel data sheets) should not be included on P&IDs.

- 4.1.2 This Practice uses the concepts of typical details with implied components where appropriate to simplify P&IDs. (See the cover sheet in Appendix B for examples.) Additional examples can be added as required.
- 4.1.3 While the intent of this Practice is to simplify the P&IDs through the use of implied components and cover sheets, this may not be compatible with the work processes or design software used for a project. Therefore, this Practice does not require the use of implied components. It is the responsibility of the project team to determine the compatibility of implied components with project needs and work processes (*e.g.*, safety reviews, material take-off method, integration plan, etc.).

## 4.2 Format

### 4.2.1 Layout

*Comment:* The layout and orientation statements specified herein are recommended as optimal, and slight deviation, although not encouraged, may be required due to space constraints.

#### 4.2.1.1 Piping Orientation

1. The top of a horizontal line and the left side of a vertical line shall be the top of a pipe.
2. The bottom of a horizontal line and the right side of a vertical line shall be the bottom of a pipe.
3. A note shall be used to clarify the orientation as required.

4.2.1.2 Drawing size shall be 22 inches x 34 inches.

4.2.1.3 Each P&ID shall be laid out to avoid clutter and allow future modifications. No more than three pieces of major equipment shall be shown on a P&ID. A set of pumps in the same service shall be one piece of equipment for the purpose of a P&ID layout in accordance with Appendix C.

#### 4.2.1.4 Flow Orientation

1. Primary flow shall be shown on each P&ID from left to right.
2. Flow-through equipment shall be shown relative to actual arrangement (*e.g.*, cooling water supply in bottom of exchanger tube bundle and cooling water return out top).

4.2.1.5 Primary process lines shall be shown heavier than secondary and utility lines as described in Section 4.2.3.

#### 4.2.1.6 Connector Symbols

1. Off-page and off-plot connectors for primary, secondary, and instrumentation lines shall be shown entering the P&ID horizontally 0.25 inch from the left inside borderline and exiting 0.25 inch horizontally from the right inside borderline in accordance with Appendix C.
2. Utility connectors can be shown at any convenient location on the body of the P&ID.



#### 4.2.1.7 Utility P&IDs

1. Utility collection/distribution P&IDs shall be laid out relative to plot plan orientation in accordance with Appendix C.
2. To depict plot plan orientation, utility off-page connectors for a utility connection/distribution P&ID may be positioned vertically in accordance with Appendix C.
3. If match lines are required on utility collection/distribution P&IDs, the lines shall match the connecting drawing match lines in accordance with Appendix C.

#### 4.2.1.8 Connector Descriptions

1. Service description, connector number, P&ID number, and origin/destination shall be shown for off-page and off-plot connectors in accordance with Appendix A-3.
2. Origin/destination shall be shown as an equipment number, line number, or loop number.
3. Service description for a piping off-page and off-plot connector shall be shown as name of fluid (*e.g.*, Cracked Gas) or line description (*e.g.*, Reactor Feed, Tower Overhead).
4. Service description for an instrument off-page and off-plot connector shall be shown as a line function (*e.g.*, Low Level Override) or equipment to be controlled (*e.g.*, PV-10014A/B).
5. Text associated with off-page and off-plot connectors on the left side of the P&ID should be left justified; text associated with off-page and off-plot connectors on the right side of a P&ID should be right justified.

4.2.1.9 Equipment arrangement shall be shown relative to its elevation to grade (*e.g.*, pumps at bottom of P&ID) in accordance with Appendix C.

4.2.1.10 A control valve actuator shall be shown above a horizontal line or left of a vertical line.

4.2.1.11 If a control valve identification bubble is required, the center point of the bubble shall be shown 0.5 inch above and 0.5 in away from the actuator in a horizontal line or 0.5 inch to the left and 0.5 inch away from the actuator in a vertical line.

4.2.1.12 The center point of an instrument bubble shall be shown 0.5 inch directly above an in-line instrument in a horizontal line or 0.5 inch directly left of an in-line instrument in a vertical line. Examples are restriction orifices and stand-alone thermowells.

4.2.1.13 Pump and compressor driver piping, instrumentation, and auxiliaries can be shown on a separate, auxiliary P&ID. "Primary" P&ID and auxiliary P&ID shall be cross-referenced.

4.2.1.14 Typical details shall be used if clutter can be eliminated without detracting from clarity. These details shall be shown on the P&ID, on an auxiliary P&ID, or on a cover sheet.

#### 4.2.4.2 Equipment Information

1. Equipment numbers shall use a text height of 0.16 inch at a weight of 0.03 inch.
2. Equipment numbers shall be underlined.
3. Equipment title and data shall use a text height of 0.1 inch at a weight of 0.02 inch.
4. Equipment text shall be justified at the top and center.
5. Equipment numbers, titles, and data for fixed or static equipment (*i.e.*, exchangers, vessels, tanks, towers, filters, and material handling) shall be shown within 2 inches from the top inside borderline of the P&ID, directly above the equipment, and on the same horizontal plane as other equipment identification.
6. Equipment numbers, titles, and data for rotating equipment (*i.e.*, pumps, blowers, compressors, and agitators) shall be shown within 2 inches from the bottom inside borderline of the P&ID, directly below the equipment, and on the same horizontal plane as other equipment identification.
7. Equipment number, title, and data shall be shown once for identical equipment with the same number, title, and service (*e.g.*, P-601A/B).

#### 4.2.4.3 Line Numbers

1. Line numbers shall be shown in accordance with Appendix A-3. See example shown in Appendix C.
2. Line numbers shall use a text height of 0.1 inch at a weight of 0.03 inch.
3. Line number text shall be placed 0.06 inch from the line and shall be lined up vertically 0.25 inch from the connector.
4. Line numbers at entering off-page and off-plot connectors shall be justified at the top and left.
5. Line numbers at exiting off-page and off-plot connectors shall be justified at the top and right.
6. Line numbering shall be shown with the orientation of the line.

#### 4.2.4.4 Text Arrangement

1. Text shall be shown horizontal if possible.
2. Vertical text shall be placed to the left of supporting graphics if possible.
3. Vertical text shall be read from bottom to top.

4.2.4.5 Abbreviations shall be in accordance with Appendix A-1.

#### 4.2.4.6 Control Valve Information

1. Control valve failure action abbreviation shall be shown at 0.06 inch directly below the control valve in horizontal lines and 0.06 inch to the right of the control valve in vertical lines. See examples shown in Appendix C.
2. If the valve size is not line size or easily inferred from adjoining pipe, reducers, or equipment, control valve size shall be shown between the actuator and valve body symbol. If necessary, control valve size can be repositioned so as not to be obscured by other items shown on actuator (*i.e.*, position switches, handwheels, etc.). See examples shown in Appendix C.
3. Control valve seat leakage criteria (*i.e.*, tight shut-off [TSO]) shall be shown between the actuator and valve body symbol. If necessary, control valve leakage criteria can be repositioned so as not to be obscured by other items shown on the actuator (*i.e.*, position switches, handwheels, etc.). See examples shown in Appendix C.

- 4.2.4.7 For PSVs, PSEs, and pressure control valves (PCVs), the device size and set pressure shall be shown close to the identification bubble. See examples shown in Appendix C.

### 4.3 Equipment

#### 4.3.1 General

##### 4.3.1.1 Equipment Symbols

1. Equipment symbols shall be shown in accordance with Appendix A-2.
2. Equipment shall be shown with simple outline representation.
3. Discretion shall be exercised for equipment symbols to not dominate the drawing, but the symbols shall be drawn large enough for clear understanding.
4. Equipment shall not be drawn to scale.
5. Equipment shall be shown relative to associated equipment both in size and general orientation.

##### 4.3.1.2 Nozzles

1. Nozzles, including spares, shall be shown on equipment as single lines.
2. Manways shall be shown as double lines.
3. Process and utility nozzles may be labeled.
4. Nozzle sizes shall be shown, unless the size is implied by piping connections.

- 4.3.1.3 Equipment not specifically identified in this Practice shall be shown with an equipment symbol that is a reasonable representation of the equipment as it will exist in the field.

4.3.1.4 Equipment shall be identified by a classification letter and sequence number. Classifications used in this Practice are shown in Section 4.3.12.

*Comment:* The classifications shown in Section 4.3.12 are used on the example P&IDs contained in Appendix C for illustrative purposes only. The classifications are only one example of classifications allowed by this Practice.

4.3.1.5 Equipment Item Number and Title/Service shall be shown as a minimum. Section 4.3.13 provides a complete list of equipment data for all equipment addressed in this Practice. For equipment not covered in this Practice, equipment data shall be shown as necessary.

4.3.1.6 Internals for equipment shall be shown as dashed lines as described in Section 4.2.2.2. Details of internals that have no significant bearing on the piping design and layout or equipment operation shall be omitted.

4.3.1.7 Equipment elevations shall not be shown unless the elevations are necessary to specify process requirements for associated equipment location or orientation relative to one another.

4.3.1.8 Associated trim (e.g., vent and drain valves, instrument bridles) for equipment shall be shown.

4.3.1.9 Auxiliary system requirements for individual pieces of equipment (e.g., lube oil systems, seal flush systems, turbine gland leak-off piping, sample systems) shall be shown on auxiliary P&IDs.

4.3.1.10 Jacketing and tracing requirements for equipment shall be shown.

4.3.1.11 The type of insulation (e.g., personnel protection, heat conservation) for equipment shall be shown as part of the equipment data. Insulation thickness shall be shown where applicable.

#### **4.3.2 Agitators**

4.3.2.1 The term agitator shall apply to mechanical mixers and aerators.

4.3.2.2 Agitators shall be shown in accordance with Appendix A-2.

#### **4.3.3 Blowers**

4.3.3.1 Blower symbols shall be shown as centrifugal or positive displacement as required.

4.3.3.2 Blowers shall be shown in accordance with Appendix A-2.

#### **4.3.4 Compressors**

4.3.4.1 The compressor symbol shall be shown for each stage of multistage compressors.

4.3.4.2 Multistaged compressors can be shown on multiple P&IDs.

4.3.4.3 Compressors shall be shown in accordance with Appendix A-2.

#### **4.3.5 Drivers**

4.3.5.1 Drivers shall be shown with the driven equipment and shall use the symbols for motors, diesel engines, and turbines.

**Table 1: Equipment Classifications**

CLASS	SUBJECT	DESCRIPTION
A	Mixing Equipment	Agitators, Aerators, Mechanical Mixers
B	Blowers	Centrifugal Blowers, Positive Displacement Blowers, Fans
C	Compressors	Centrifugal, Reciprocating, Screw, Vacuum
D	Mechanical Drivers	Electric and Pneumatic Motors, Diesel Engines, Steam and Gas Turbines
E	Heat Exchangers	Unfired Heat Exchangers, Condensers, Coolers, Reboilers, Vaporizers and Heating Coils, Double Pipe, Spiral, Plate & Frame, Air Coolers
F	Furnaces	Fired Heaters, Furnaces, Boilers, Kilns
P	Pumps	Horizontal and Vertical Centrifugal, Positive Displacement, Vertical Canned, Screw, Gear, Sump
R	Reactors	
T	Towers / Columns	
TK	Tanks	API atmospheric and low pressure
U	Miscellaneous Equipment	Filters, Bins, Silos
V	Vessels	Separators, Driers, Accumulators, Drums

#### 4.3.13 Equipment Data

The following equipment information shall be shown on the P&ID in relation to the appropriate equipment symbol and in accordance with Section 4.2.4.2:

##### 4.3.13.1 Agitators, Mixers

- Equipment/Item Number
- Title/Service
- Power Requirements
- Materials of Construction

##### 4.3.13.2 Blowers

- Equipment/Item Number
- Title/Service
- Capacity (Flow and D/P)
- Power Requirements
- Materials of Construction

##### 4.3.13.3 Compressors

- Equipment/Item Number
- Title/Service
- Capacity (Flow and D/P)

## 4.5 Instrumentation and Controls

### 4.5.1 Symbols

- 4.5.1.1 Instrument and control symbols shall be shown in accordance with Appendix A-4. (Reference *ISA-5.1* for additional details)
- 4.5.1.2 The conventions established by *ISA-5.1* shall be followed for tagging and numbering of instrument and control devices. (Reference Appendix A-4)

*Comment:* The tagging and numbering scheme described in the following example is used on the example P&IDs contained in the Appendixes for illustrative purposes only. This example tagging and numbering scheme is only one example of tagging and numbering schemes described in this Practice. The tagging structure is shown in the following example:

01 FC 100 01

01 – Plant Number (shall not appear on P&IDs or in a bubble)

FC – Function Identifier (*e.g.*, Flow Controller)

100 – Equipment (or P&ID) Number (optional)

01 – Loop Sequence Number.

Breaks in the instrument bubble may be used to accommodate longer tag numbers.

- 4.5.1.3 All measurement types shall be identified by an ISA symbol.
- 4.5.1.4 If necessary, a descriptive text label may be added (*e.g.*, analysis components like CO, H<sub>2</sub>, CH<sub>4</sub>, or unique flow measurement devices like “Mass”).
- 4.5.1.5 Interlock symbols shall be depicted as follows:
  - a. For discrete, hardware-based interlocks, the conventional diamond symbol shall be used in accordance with *ISA-5.1* and *ISA-5.2*.
  - b. For PLC-based interlocks, the diamond-in-a-box symbol shall be used in accordance with *ISA-5.1* and *ISA-5.2*.
  - c. For DCS-based interlocks, the DCS symbol (bubble-in-a-box) shall be used.
  - d. For PLCs integral to the DCS, the PLC symbol (diamond-in-a-box) shall be used.

*Comment:* Reference Appendix A-4 and Section 4.5.6 for additional information.

- 4.5.1.6 Directional arrows on instrumentation signal lines shall be used only if the function is not obvious (*e.g.*, cascades, selectors, interlocks).
- 4.5.1.7 Instrument function symbols, shown in Appendix A-4, shall be used to clarify the function of certain tagged instrument bubbles. The symbol shall be placed outside the bubble at the upper right.

3. The symbols shown in Appendix A-4 shall be used for pressure and temperature regulators.

#### 4.5.3.2 Automated Valves

1. Automated valve fail actions shall be shown with text (FC/FO/FL/FI) in accordance with ISA-5.1. (Reference Section 4.2.4.6)

*Comment:* Using stem arrows as outlined in ISA-5.1 is not recommended.

2. For multi-port automated valves, FL and FI shall be used where appropriate.

*Comment:* FO and FC shall not be used; instead, arrows shall be used to show fail position flow paths. Note that multiple arrows may be required.

3. Valves with different fail actions for loss of signal and for loss of motive power require an explanatory note.
4. Valve body sizes shall be shown for all automated valves if not line sized or otherwise implied. (Reference Section 4.2.4.6)
5. Automated valve specifications or commodity codes shall not be shown.
6. For automated valves, tight shut-off requirements shall be identified by using the abbreviation "TSO." (Reference Section 4.2.4.6)

*Comment:* TSO defines the seat shut-off requirements for a new valve. Testing requirements, if any, are defined in other unit operation documents.

#### 4.5.3.3 Identifying Tags

1. Valve identifying tags with bubbles shall not be shown if the associated loop tag is readily apparent.
2. An identifying tag with a bubble shall be shown for split range valves, self-contained regulators, or valves located on a separate P&ID from its controller. (Reference Section 4.2.1.6)

- 4.5.3.4 The ranges (*e.g.*, 0-50%, 50-100%) shall be shown for split range control valves.

*Comment:* The preferred labeling is controller percentage output because it applies to both pneumatic and electronic systems.

- 4.5.3.5 Valve positioners shall not be shown unless necessary to clarify loop operation (*e.g.*, if used with trip solenoids or pneumatic trip relays).

*Comment:* If shown, valve positioners are normally included with the automated valve symbol and are not tagged.

#### 4.5.6 Interlocks and Alarms

4.5.6.1 Interlocks shall be shown only symbolically on the P&ID.

4.5.6.2 The functional definition shall be shown on auxiliary documents (*e.g.*, binary logic diagrams, descriptive narratives, truth tables).

*Comment:* Interlocks can be designed for a variety of functions, from simple process sequences to complex safety shutdown systems. A variety of hardware can be used for implementation (*e.g.*, DCS, PLC, relays, redundant, fault-tolerant Safety Interlock Systems).

Alarms can be similarly designed in a variety of ways. Alarms come from hardware, over serial links, from DCS software and can be shown on a variety of facility documents, including P&IDs, alarm summaries, logic and loop diagrams, and operating procedures.

Because of this variety, along with individual owner interpretations of the requirements of *OSHA 1910.119* and *ISA -84.01*, many documentation aspects of interlock and alarm system design should be defined by the owner.

4.5.6.3 Logic functions or interlocks shall be shown with the proper symbols in accordance with Section 4.5.1.

4.5.6.4 Binary logic gates, input/output tables, or descriptive narratives shall not be shown.

4.5.6.5 All logic function and interlock symbols shall contain an identification that provides reference to a unique logic diagram, narrative, truth table, or program. The reference shall be located within the interior of the symbol. The format of the reference shall be determined by the owner. Descriptive text or a note reference can be placed outside the symbol.

4.5.6.6 If Safety Instrumented Systems (SIS) are distinguished from other interlock systems, the preferred method shall be to add an "S" prefix to the unique interlock identification.

4.5.6.7 Each interlock shall be uniquely labeled, using a serial (not parallel) tagging scheme. The "S" prefix shall not be used to distinguish a unique interlock label.

*Comment:* A valid tagging scheme shall be I-100, I-101, SI-200, SI-201. The scheme I-100, SI-100 should not be used.

4.5.6.8 The type of logic solver hardware or level of redundancy shall not be shown except through the normal use of ISA symbols and the input and output signals described in Section 4.5.1 and the Appendixes.

4.5.6.9 Classifications or Safety Integrity Levels (SIL) shall not be shown for interlocks.

4.5.6.10 All operator-initiated interlock trip and reset hand switches shall be shown.



- 4.5.6.11 If used, all bypass hand switches for SIS interlocks shall be shown, including all individual initiator and system bypass switches.

*Comment:* Unnecessary clutter can be avoided by use of a table or reference note if large numbers of bypasses are necessary.

- 4.5.6.12 All hardwired alarms shall be shown.
- 4.5.6.13 All alarms that require engineering or other review and approval based on safety or operability shall be shown.
- 4.5.6.14 Hardware-based diagnostic alarms shall be shown.
- 4.5.6.15 Software-based diagnostic alarms shall be shown only if safety or operationally related (e.g., defined in safety reviews).

*Comment:* Measurement out-of-range alarms are an example of software diagnostic alarms not generally shown.

- 4.5.6.16 Required alarms shall be shown with tag and level (e.g., PAH), but alarm trip points or settings shall not be shown.
- 4.5.6.17 For alarms based on analog measurements, the functional tag (e.g., PI) shall be shown inside the bubble and the alarm levels shall be shown outside the bubble.
- 4.5.6.18 High alarms (e.g., H, HH) shall be placed at the upper right outside the bubble, and low alarms (e.g., L, LL) shall be placed at the lower right outside the bubble.

*Comment:* The alarm modifier (A) should not be shown.

- 4.5.6.19 For discrete alarm points (on/off signals), the complete functional tag and alarm level (e.g., PAH) shall be shown inside the bubble.
- 4.5.6.20 Standard ISA-5.1 abbreviations shall be used for both trip and alarm functions (e.g., LSHH and LAHH).

#### 4.5.7 DCS Points

- 4.5.7.1 A DCS point shall be shown if operations manipulates the process with it or receives information from it, or if the point is essential to understanding the functional operation of the process controls.

*Comment:* It is not necessary for every point configured in a DCS to be shown. It is not necessary for implied functions (e.g., I for indicate, R for recorder) to be included in every DCS point tag.

It is not the intent of this section to define which DCS points to show for every supplier of a DCS or each type of system that can communicate with a DCS via a software link (e.g., analyzer data highways, anti-surge control systems, vibration monitoring systems, Safety Instrumented Systems, PLCs, tank gauging systems).

## Appendixes Summary

---

The Appendixes of this Practice contain tables of commonly used symbols, abbreviations and other identifiers; typical details; and example P&IDs.

Appendix A contains symbols and text grouped by function. The symbols and text are shown the same size as would be utilized for a standard, full-size (22 inches x 34 inches) P&ID.

Appendix B contains the same data as Appendix A, organized into cover sheets. Cover sheets are also commonly referred to as lead sheets or legend sheets.

Appendix C contains example P&IDs that illustrate the text and utilize the symbols and legends on the cover sheets.

*Comment:* The cover sheets and P&IDs are drawn as standard, full-size (22 inches x 34 inches) P&IDs, but reduced to standard 8-1/2 inch x 11-inch pages for electronic distribution purposes. It is recommended that the cover sheets and P&IDs be printed on 11-inch x 17-inch pages.

Sample - No Commercial Use

## **Appendix A – Tables and Symbols**

### **A-1 Format Tables and Symbols**

1. Abbreviations
2. Miscellaneous Symbols

### **A-2 Equipment Tables and Symbols**

1. Pumps
2. Compressors and Blowers
3. Drivers and Agitator/Mixer
4. TEMA Type Exchangers
5. Miscellaneous Exchangers
6. Storage Tanks
7. Storage Tanks
8. Storage Sphere and Furnace
9. Miscellaneous Vessel Details
10. Jacketed Pressure Vessels

### **A-3 Piping Tables and Symbols**

1. Line Data Identification
2. Line Service Codes
3. Piping Line Symbols
4. Valve Symbols
5. Piping Specialty Items
6. Piping Fittings
7. Connectors and Tie-In Symbol
8. Drain Connectors
9. Notes

### **A-4 Instruments & Controls Tables and Symbols**

1. Instrument Identification Letters
2. General Instrument Symbols
3. Instrument Function Symbols
4. Instrument Line Symbols
5. Primary Element Symbols (Flow)
6. Control Valve Actuator Symbols
7. Self-Actuated Devices
8. Miscellaneous Instrument Symbols

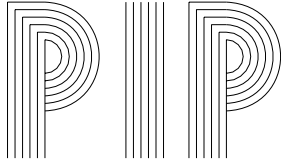

PROCESS INDUSTRY PRACTICES  
APPENDIX

A-1

ISSUED: 7/15/98  
REAFFIRMED: APRIL 2008  
PAGE 1 OF 2

ABBREVIATIONS

PRACTICE REF. PIC001

AG	ABOVE GROUND	MAX	MAXIMUM
ATM	ATMOSPHERE	MIN	MINIMUM
BL	BATTERY LIMIT	MOV	MOTOR OPERATED VALVE
BTL	BOTTOM TANGENT LINE	MTL	MATERIAL
BYP	BYPASS	MW	MANWAY
CC	CHEMICAL CLEANOUT	NC	NORMALLY CLOSED
CL	CENTERLINE	NNF	NORMALLY NO FLOW
CO	CLEANOUT	NO	NORMALLY OPEN
CONN	CONNECTION	NOZ	NOZZLE
CSC	CAR SEAL CLOSED	O/C	OPEN/CLOSE
CSO	CAR SEAL OPEN	O/O	ON/OFF
CTR	CENTER	OP	OUTPUT
DCS	DISTRIBUTED CONTROL SYSTEM	OSBL	OUTSIDE BATTERY LIMITS
DES	DESIGN	OVHD	OVERHEAD
DIA	DIAMETER	PLC	PROGRAMMABLE LOGIC CONTROLLER
DP	DESIGN PRESSURE	PRESS	PRESSURE
D/P	DIFFERENTIAL PRESSURE	PV	PROCESS VARIABLE
DRN	DRAIN	(R)	RELOCATED
DT	DESIGN TEMPERATURE	REQD	REQUIRED
DWG	DRAWING	RTD	RESISTANCE TEMPERATURE DETECTOR
(E)	EXISTING	SC	SAMPLE CONNECTION
EL	ELEVATION	SCH	SCHEDULE
ESD	EMERGENCY SHUTDOWN	SD	SHUTDOWN
FOF	FACE OF FLANGE	SG	SPECIFIC GRAVITY
(F)	FURNISHED	SIS	SAFETY INSTRUMENTED SYSTEM
FC	FAIL CLOSED	SO	STEAM OUT
FI	FAIL INDETERMINATE	SP	SET POINT
FL	FAIL LOCKED (LAST POSITION)	SS	STAINLESS STEEL
FLG	FLANGE	S/S	START/STOP
FO	FAIL OPEN	STD	STANDARD
FP	FULL PORT	T/C	THERMOCOUPLE
FV	FULL VACUUM	TDH	TOTAL DIFFERENTIAL HEAD
GO	GEAR OPERATED	TEMP	TEMPERATURE
GR	GRADE	THRD	THREADED
HC	HOSE CONNECTION	TL	TANGENT LINE
HDR	HEADER	TSO	TIGHT SHUT-OFF
HH	HAND HOLE	T/T	TANGENT TO TANGENT
HOA	HAND/OFF/AUTOMATIC	TYP	TYPICAL
HP	HIGH PRESSURE	UG	UNDERGROUND
HPT	HIGH POINT	VNT	VENT
IAS	INSTRUMENT AIR SUPPLY	VAC	VACUUM
ISBL	INSIDE BATTERY LIMITS	VB	VORTEX BREAKER
LC	LOCKED CLOSED	W/	WITH
LO	LOCKED OPEN	W/O	WITHOUT
LP	LOW PRESSURE		
LPT	LOW POINT		

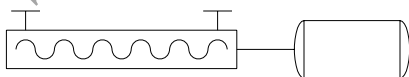
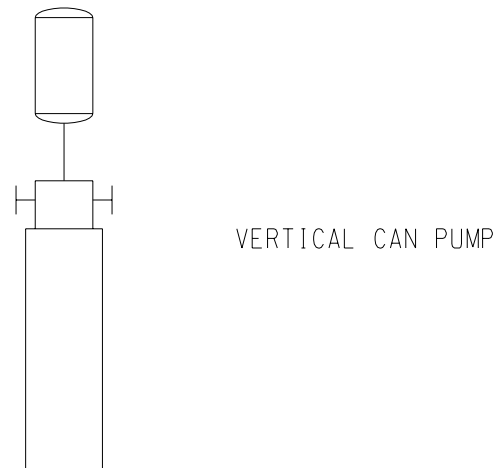
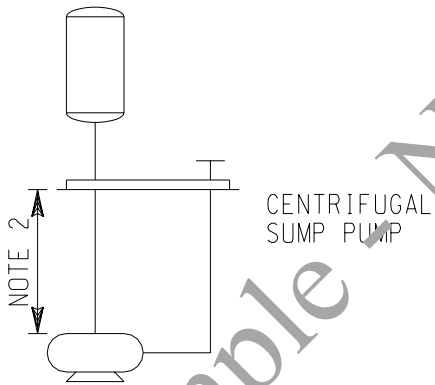
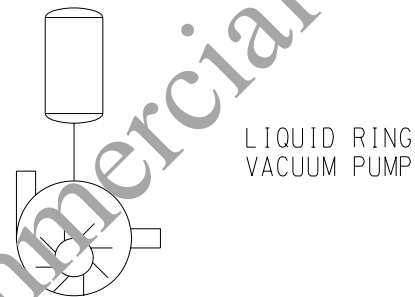
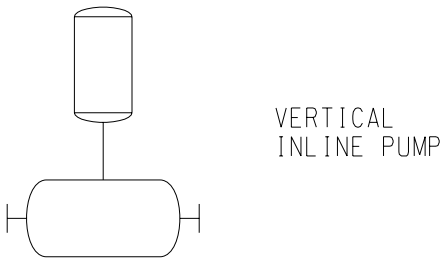
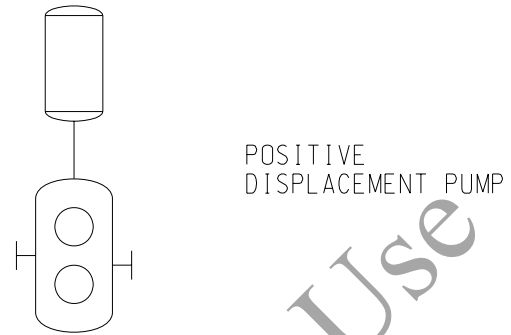
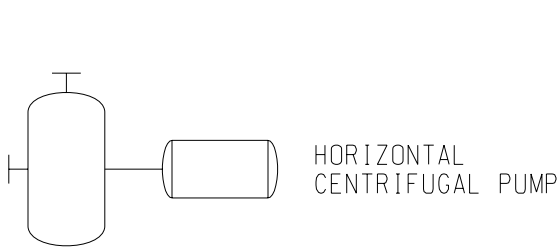
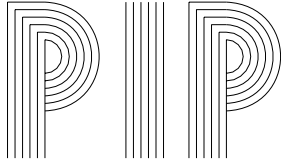

PROGRESSIVE CAVITY PUMP

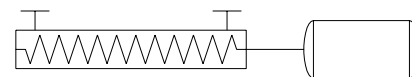

SCREW PUMP

NOTES:

1. SYMBOLS ARE SHOWN HERE AT ACTUAL SIZE USED ON 22"x34" DOCUMENTS.
2. LENGTH VARIES DEPENDING UPON DEPTH OF SUMP.
3. MOTORS SHOWN HERE TO ILLUSTRATE DRIVER ORIENTATION. FOR DRIVER SYMBOLS, SEE APPENDIX A-2, p.3.

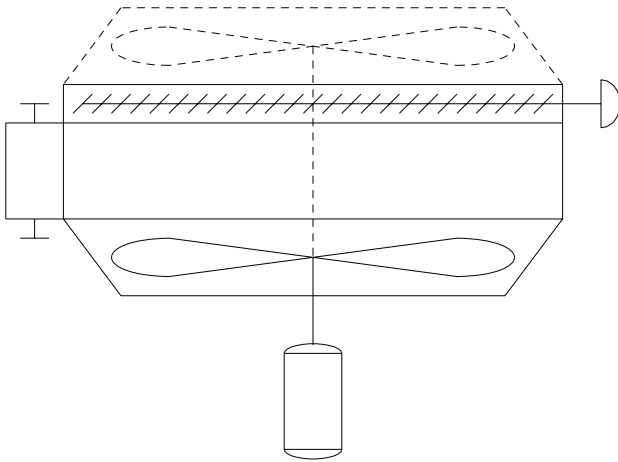
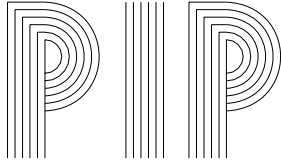

AIR COOLED EXCHANGER  
(LOUVERS OPTIONAL)

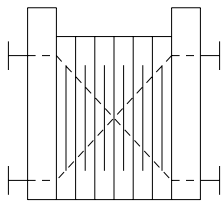
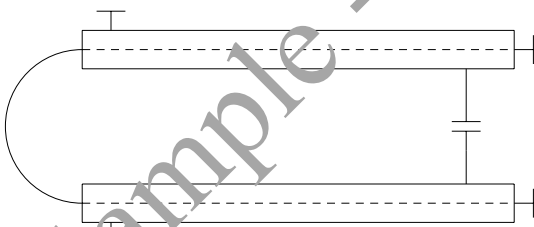
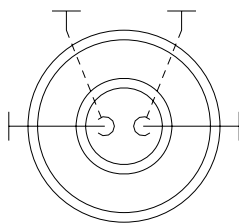

PLATE AND FRAME EXCHANGER



DOUBLE PIPE EXCHANGER



SPIRAL EXCHANGER

NOTE: SYMBOLS SHOWN HERE AT ACTUAL SIZE USED ON 22"x34" DOCUMENTS.

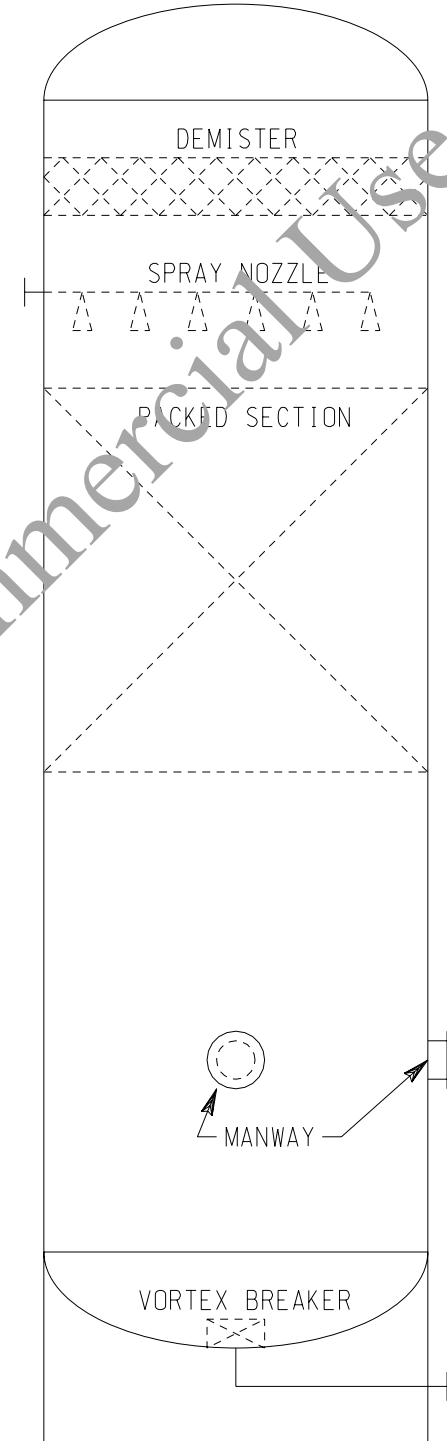
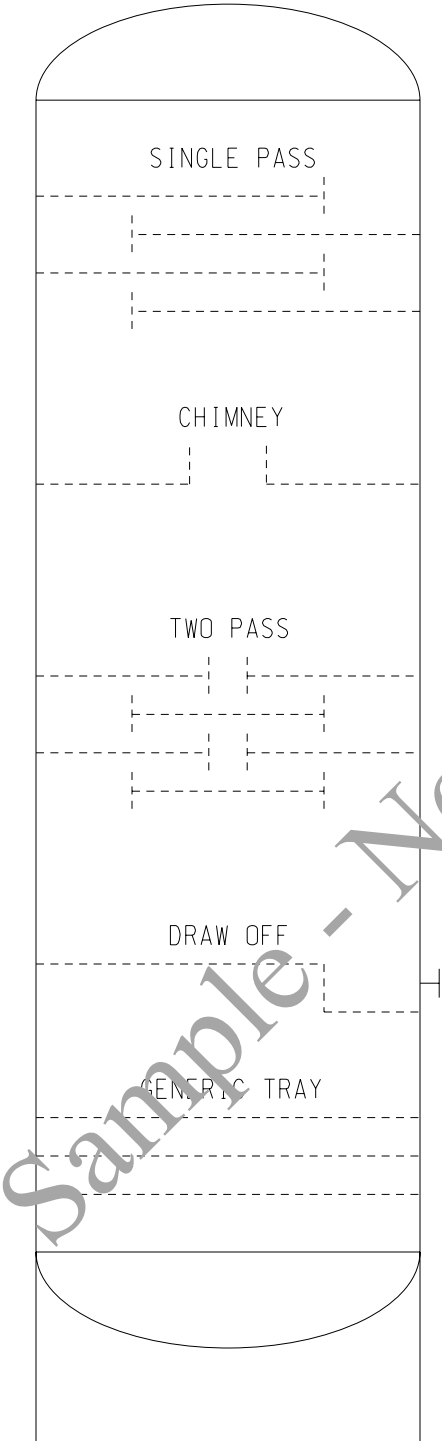
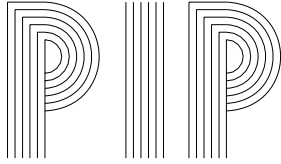

Sample - No Commercial Use

NOTE: ACTUAL SIZE WILL VARY.

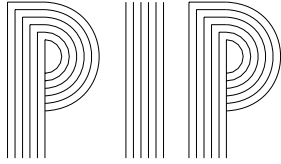

PROCESS INDUSTRY PRACTICES  
APPENDIX

A-3

ISSUED: APRIL 2008  
REAFFIRMED:  
PAGE 1 OF 9

LINE DATA  
IDENTIFICATION

PRACTICE REF. PIC001

UNIT/AREA SERVICE SEQUENCE SIZE LINE CLASS  
(NUMERIC) (ALPHA) (NUMERIC) (NUMERIC) (NOTE 1)

XX - XXX - XXXXX - XXXY - XXXXXXXX  
(-----)

XXXX - XXXX - XXXX

INSULATION TYPE INSULATION THICKNESS OPTIONAL  
(NOTE 2) (NUMERIC) (USER DEFINED)

NOTES:

1. DEFINED BY PIP PNSM0001; PIPING LINE CLASS DESIGNATOR SYSTEM. FOR INSTRUMENT PIPING AND TUBING SPECIFICATION, SEE PIP PCS1P001.
2. DEFINED BY PIP INEG1000; INSULATION DESIGN AND TYPE CODES.
3. USER IS NOT LIMITED TO THE NUMBER OF SPACES REPRESENTED BY THE "XX" CHARACTERS IN THE LINE DATA IDENTIFICATION EXAMPLE.



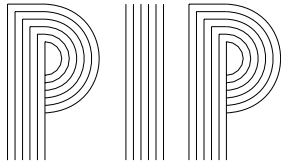

PROCESS INDUSTRY PRACTICES  
APPENDIX

**A-3**

ISSUED: 7/15/98  
REAFFIRMED: APRIL 2008  
PAGE 5 OF 9

PIPING  
SPECIALTY ITEMS

PRACTICE REF. PIC001



Y-TYPE STRAINER

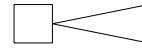

EJECTOR/EDUCTOR



CONE STRAINER



REMOVABLE SPOOL



TEMPORARY STRAINER



DESUPERHEATER



T-TYPE STRAINER



FLEXIBLE HOSE



DUPLEX STRAINER



EXPANSION JOINT



BASKET STRAINER



DAMPER



FILTER



BREATHER



DETONATION ARRESTOR



VENT COVER



FLAME ARRESTOR



IN-LINE MIXER



STEAM TRAP



DIVERTER VALVE



EXHAUST HEAD



ROTARY VALVE



IN-LINE SILENCER



EXCESS FLOW VALVE

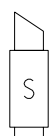

VENT SILENCER



PULSATION DAMPENERS

NOTE: SYMBOLS ARE SHOWN HERE AT ACTUAL SIZE USED ON 22"x34" SIZE DOCUMENTS

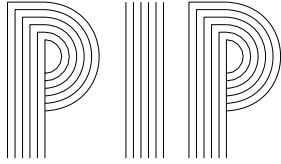

PROCESS INDUSTRY PRACTICES  
APPENDIX

**A-4**

ISSUED: 7/15/98  
REAFFIRMED: APRIL 2008  
PAGE 1 OF 8

INSTRUMENT IDENTIFICATION  
LETTERS

PRACTICE REF. PIC001

FIRST LETTER			SUCCEEDING LETTERS		
	MEASURED OR INITIATING VARIABLE	MODIFIER	READOUT OR PASSIVE FUNCTION	OUTPUT FUNCTION	MODIFIER
A	ANALYSIS		ALARM		
B	BURNER, FLAME, COMBUSTION		USER'S CHOICE	USER'S CHOICE	USER'S CHOICE
C	USER'S CHOICE (TYPICALLY CONDUCTIVITY - ELECTRICAL)			CONTROL	CLOSED
D	USER'S CHOICE (TYPICALLY DENSITY OR SPECIFIC GRAVITY)	DIFFERENTIAL			DIVERT
E	VOLTAGE		SENSOR (PRIMARY ELEMENT)		
F	FLOW RATE	RATIO (FRACTION)			
G	USER'S CHOICE OR GAUGING (DIMENSIONAL)		GLASS, VIEWING DEVICE		
H	HAND				HIGH
I	CURRENT (ELECTRICAL)		INDICATE		
J	POWER	SCAN			
K	TIME, TIME SCHEDULE	TIME RATE OF CHANGE		CONTROL STATION	
L	LEVEL		LIGHT		LOW
M	USER'S CHOICE (TYPICALLY MOISTURE OR HUMIDITY)	MOMENTARY			MIDDLE, INTERMEDIATE
N	USER'S CHOICE		USER'S CHOICE	USER'S CHOICE	USER'S CHOICE
O	USER'S CHOICE		ORIFICE, RESTRICTION		OPEN
P	PRESSURE, VACUUM		POINT (TEST) CONNECTION		
Q	QUANTITY OR HEAT DUTY	INTEGRATE, TOTALIZE			
R	RADIATION		RECORD		
S	SPEED, FREQUENCY	SAFETY		SWITCH	
T	TEMPERATURE			TRANSMIT	THROUGH
U	MULTIVARIABLE		MULTIFUNCTION	MULTIFUNCTION	MULTIFUNCTION
V	VIBRATION, MECHANICAL ANALYSIS			VALVE, DAMPER, LOUVER	
W	WEIGHT, FORCE		WELL		
X	UNCLASSIFIED	X AXIS	UNCLASSIFIED	UNCLASSIFIED	UNCLASSIFIED
Y	EVENT, STATE OR PRESENCE	Y AXIS		RELAY, COMPUTE, CONVERT	
Z	POSITION, DIMENSION	Z AXIS		DRIVER, ACTUATOR, UNCLASSIFIED FINAL CONTROL ELEMENT	

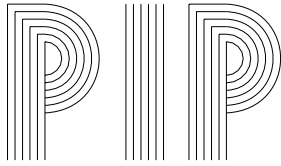

CONTROL VALVE  
ACTUATOR SYMBOLS (NOTE 2)

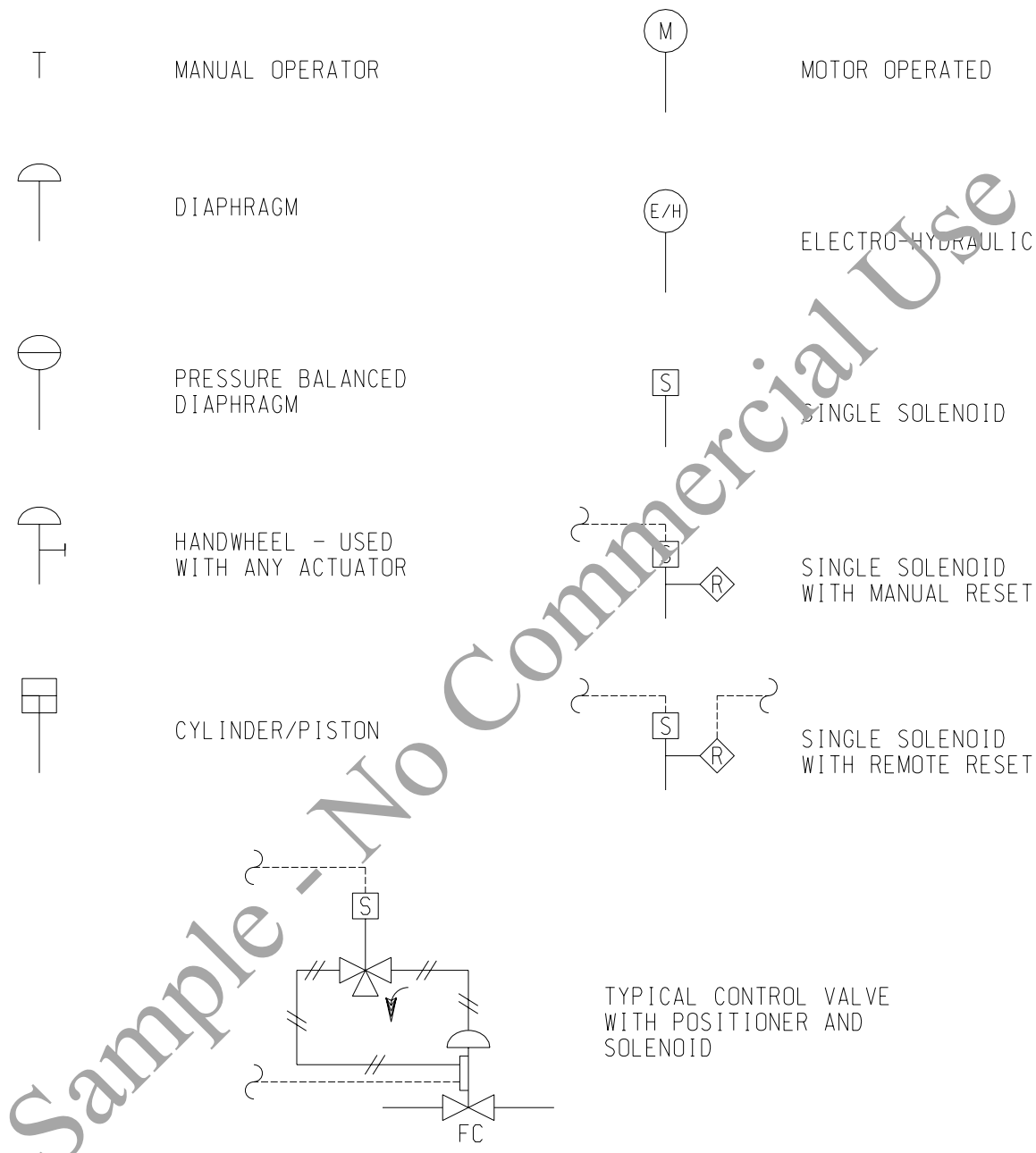

NOTE:

- 1. SYMBOLS ARE SHOWN HERE AT ACTUAL SIZE USED ON 22"x34" SIZE DOCUMENTS
- 2. SEE PIPING APPENDIX A-3, p.4 FOR TYPICAL VALVE SYMBOLS. BY ADDING AN ACTUATOR TO THE BASIC VALVE SYMBOL, THE VALVE BECOMES A CONTROL VALVE.

## **Appendix B – Cover Sheets**

- B-1: Symbols and Nomenclature – Typical Piping
- B-2: Symbols and Nomenclature – Typical Instrumentation
- B-3: Symbols and Nomenclature – Typical Equipment
- B-4: Typical Details with Implied Components

Note: The example cover sheets in this Appendix are not all-inclusive of the potential uses of implied components. The implied component examples shown do not cover all actual occurrences or design possibilities for instrument assemblies, such as the level bridges shown. The user must ensure that the cover sheets capture their piping/instrument requirements for their use of implied components. There are many more systems that may require a cover sheet explanation to show the implied components – pump seals, sampling systems, analyzer systems for example, as well as other types of level systems than those shown here.

**INSTRUMENT LINE SYMBOLS**

INSTRUMENT SUPPLY OR CONNECTION TO PROCESS	—
PNEUMATIC SIGNAL	— / / / /
ELECTRIC SIGNAL	- - - - -
HYDRAULIC SIGNAL	—   —   —   —
CAPILLARY TUBE	— x — x — x — x
ELECTROMAGNETIC, SONIC, OPTICAL, OR NUCLEAR SIGNAL	— ~ ~ ~ ~
SOFTWARE OR DATA LINK	— o — o — o — o
MECHANICAL LINK	— • — • — • — •
FIBERBUS	— □ — □ — □ — □

**MISCELLANEOUS SYMBOLS**

ESD	CHEMICAL SEAL/DIAPHRAGM
	PILOT LIGHT OR GAUGE GLASS ILLUMINATOR
	DUAL FUNCTION OR INSTRUMENTS SHARING COMMON HOUSING
	UNDEFINED INTERLOCK LOGIC
	INSTRUMENT WITH LONG TAG NUMBER

**CONTROL VALVE ACTUATOR SYMBOLS**

T	MANUAL OPERATOR
	DIAPHRAGM
	PRESSURE BALANCED DIAPHRAGM
	HANDWHEEL — USED WITH ANY ACTUATOR
	CYLINDER/PISTON
M	MOTOR OPERATED
	ELECTRO-HYDRAULIC
	SINGLE SOLENOID WITH REMOTE RESET
	SINGLE SOLENOID WITH MANUAL RESET

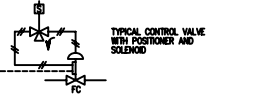

**PRIMARY ELEMENT SYMBOLS (FLOW)**

	GENERAL SYMBOL IN-LINE ELEMENT XX = FS, FG, FE, FT
	IN-LINE FLOW ELEMENT WITH INTEGRAL TRANSMITTER XXXX = MASS, CORIOLIS, THERMAL, W.T. ORifice
	IN-LINE FLOW ELEMENT WITH SEPARATE TRANSMITTER XXXX = MASS, CORIOLIS, THERMAL...
	ORIFICE
	MAGNETIC
	TURBINE OR PROPELLER
	ULTRASONIC
	VORTEX
	PILOT TUBE
	AVERAGING PITOT TUBE
	FLOW NOZZLE
	VENTURI
	WEDGE METER
	FLUME
	WEIR
	POSITIVE DISPLACEMENT
	ORIFICE IN QUICK CHANGE FITTING
	TARGET
	ROTAMETER (OR PURGE) (SHOWING WITH OPTIONAL INTERNAL VALVE)
	FLOW SWITCH * = N/A
	FLOW GLASS
	FLOW CONDITIONING DEVICE (e.g., STRAIGHTENING DEVICES)
	RESTRICTION ORIFICE

**INSTRUMENT FUNCTION SYMBOLS**

	SUMMING
	AVERAGING
	DIFFERENCE
	MULTIPLYING
	DIVIDING
	SQUARE ROOT
	EXPONENTIAL
	CONVERSION INPUT/OUTPUT
	HIGH SELECT
	LOW SELECT
	HIGH LIMIT
	LOW LIMIT
	BIAS
	UNSPECIFIED FUNCTION
	USER DEFINED

**SELF-ACTUATED DEVICES**

	RUPTURE DISC OR SAFETY HEAD FOR PRESSURE RELIEF (EXPLOSION PANEL)
	VACUUM RELIEF VALVE
	PRESSURE RELIEF OR SAFETY VALVE
	PRESSURE AND VACUUM RELIEF VALVE OR CONSERVATION VENT
	BUCKLING PIN
	PILOT OPERATED RELIEF VALVE WITH INHERENT SENSITIVE SENSOR (USE APPROPRIATE RELIEF VALVE SYMBOL)
	PRESSURE REDUCING REGULATOR (SELF-CONTAINED)
	BACK PRESSURE REGULATOR (SELF-CONTAINED)
	BACK PRESSURE REGULATOR W/ EXTERNAL TAP
	PRESSURE REDUCING REGULATOR W/ EXTERNAL TAP
	DIFFERENTIAL PRESSURE REDUCING REGULATOR
	TEMPERATURE REGULATOR (FIELD SYSTEM TYPE)

**GENERAL INSTRUMENT SYMBOLS**

LOCATION/ACCESSIBILITY	DISCRETE INSTRUMENTS	SHARED DISPLAY AND CONTROL (DCS)	DISCRETE HARDWARE INTERLOCK
<b>FIELD MOUNTED</b> 1. FIELD OR LOCALLY MOUNTED. 2. ACCESSIBLE TO AN OPERATOR AT DEVICE.			
<b>PRIMARY LOCATION NORMALLY ACCESSIBLE TO AN OPERATOR</b> 1. CENTRAL OR MAIN CONTROL ROOM. 2. FRONT OF MAIN PANEL OR CONSOLE MOUNTED. 3. FRONT OR REAR OF NEED DISPLAY. 4. ACCESSIBLE TO AN OPERATOR AT DEVICE OR CONSOLE.			
<b>PRIMARY LOCATION NORMALLY UNACCESSIBLE TO AN OPERATOR</b> 1. CENTRAL OR MAIN CONTROL ROOM. 2. REAR OF PANEL OR CABINET MOUNTED. 3. NOT NORMALLY ACCESSIBLE TO AN OPERATOR AT DEVICE OR CONSOLE.			
<b>ALTERNATE LOCATION NORMALLY ACCESSIBLE TO AN OPERATOR</b> 1. SECONDARY OR LOCAL CONTROL ROOM. 2. FIELD OR LOCAL CONTROL PANEL. 3. FRONT OR REAR OF SECONDARY OR LOCAL PANEL MOUNTED. 4. NOT NORMALLY ACCESSIBLE TO AN OPERATOR AT DEVICE OR CONSOLE.			
<b>MULTI-LOCATION NORMALLY ACCESSIBLE TO AN OPERATOR</b> 1. SECONDARY OR LOCAL CONTROL ROOM. 2. FIELD OR LOCAL CONTROL PANEL. 3. FRONT OR REAR OF SECONDARY OR LOCAL PANEL MOUNTED. 4. NOT NORMALLY ACCESSIBLE TO AN OPERATOR AT DEVICE OR CONSOLE.			

**INSTRUMENT IDENTIFICATION LETTERS**

FIRST LETTER	SUCCEEDING LETTERS			
	MEASURED OR INITIATING VARIABLE	MODIFIER	READOUT OR PASSIVE FUNCTION	OUTPUT FUNCTION
A	ANALYSIS		ALARM	
B	BURNER, FLAME, COMBUSTION		USER'S CHOICE	USER'S CHOICE
C	USER'S CHOICE (TYPICALLY CONDUCTIVITY — ELECTRICAL)			CLOSED
D	USER'S CHOICE (TYPICALLY DENSITY OR SPECIFIC GRAVITY)		DIFFERENTIAL	
E	VOLTAGE		SENSOR (PRIMARY ELEMENT)	
F	FLOW RATE	RATIO (FRACTION)		
G	USER'S CHOICE OR GAUGING (DIMENSIONAL)		GLASS, WEIGHING DEVICE	
H	HAND			HIGH
I	CURRENT (ELECTRICAL)		INDICATE	
J	POWER	SCAN		
K	TIME, TIME SCHEDULE	TIME RATE OF CHANGE		CONTROL STATION
L	LEVEL		LIGHT	LOW
M	USER'S CHOICE (TYPICALLY MOISTURE OR HUMIDITY)	MOMENTARY		MIDDLE, INTERMEDIATE
N	USER'S CHOICE		USER'S CHOICE	USER'S CHOICE
O	USER'S CHOICE		ORIFICE, RESTRICTION	OPEN
P	PRESSURE, VACUUM		POINT (TEST) CONNECTION	
Q	QUANTITY OR HEAT DUTY	INTEGRATE, TOTALIZE		
R	RAMINATION		RECORD	
S	SPEED, FREQUENCY	SAFETY		SWITCH
T	TEMPERATURE		TRANSMIT	THROUGH
U	MULTIFUNCTION		MULTIFUNCTION	MULTIFUNCTION
V	VIBRATION, MECHANICAL ANALYSIS		VALVE, DAMPER, LOUVER	
W	WEIGHT, FORCE		WELL	
X	UNCLASSIFIED	X AXIS	UNCLASSIFIED	UNCLASSIFIED
Y	EVENT, STATE OR PRESENCE	Y AXIS		RELAY, COMPUTE, CONVERT
Z	POSITION, DIMENSION	Z AXIS		DRIVER, ACTUATOR, UNCLASSIFIED FINAL CONTROL ELEMENT

- NOTES:**
- REFERENCE ISA S5.1, S5.2 & S5.3.
  - FLOW ASSUMED LEFT TO RIGHT AS SHOWN.
  - MULTIPLE LOCATIONS OF THE SAME TYPE CAN BE DISTINGUISHED BY ADDING A TEXT LABEL OR NOTE.
  - FOR VALVE SYMBOLS, SEE APPENDIX B, p.1.

PROCESS INDUSTRY PRACTICES  
PIPING AND INSTRUMENTATION DIAGRAM

SYMBOLS AND NOMENCLATURE  
TYPICAL INSTRUMENTATION COVER SHEET  
APPENDIX B

**PIP**

PRACTICE REF. PICO01  
ISSUED: APRIL 2008  
REPLACES: PIP-00-002  
PAGE 2 OF 4  
PIP-00-002

PUMPS ①

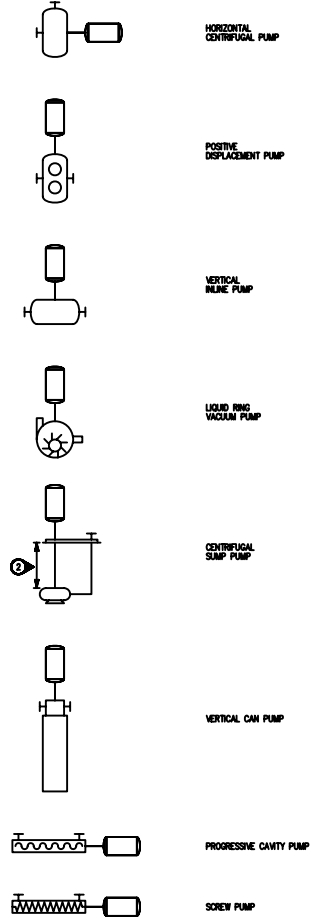

COMPRESSORS & BLOWERS ①

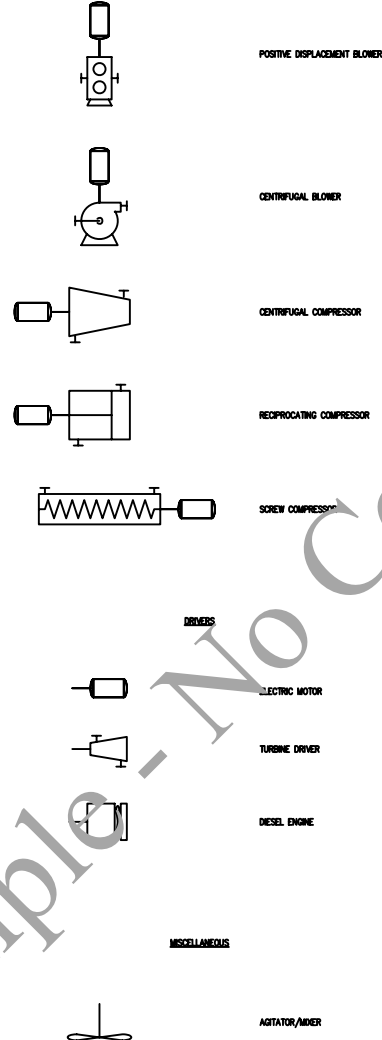

HEAT EXCHANGERS ②

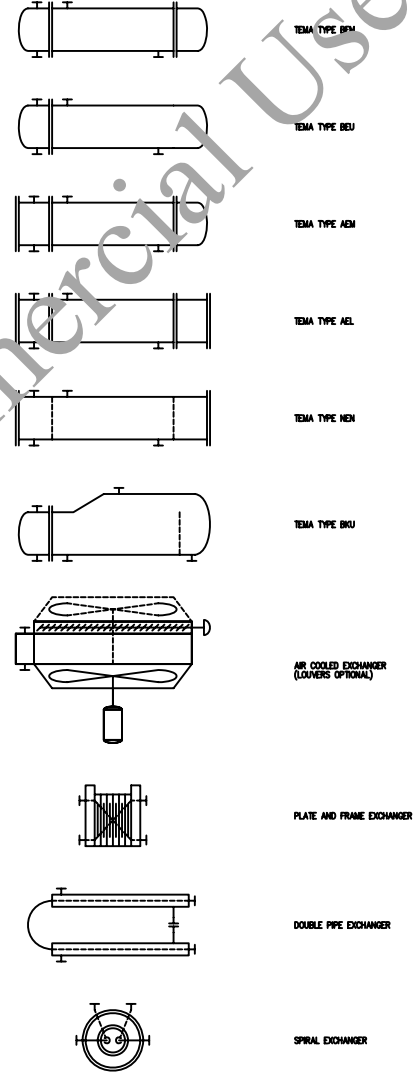

- NOTES:
1. MOTORS ARE SHOWN HERE TO ILLUSTRATE DRIVER ORIENTATION.
  2. LENGTH VARIES DEPENDING UPON DEPTH OF SUMP.
  3. CONSULT TEMA FOR TYPES OTHER THAN THOSE SHOWN.
  4. EXCHANGERS SHOWN HERE REPRESENT SINGLE PASS SHELL AND EVEN NUMBER OF TUBE PASSES.

PROCESS INDUSTRY PRACTICES  
PIPING AND INSTRUMENTATION DIAGRAM

SYMBOLS AND NOMENCLATURE  
TYPICAL EQUIPMENT COVER SHEET  
APPENDIX B

**PIP**

PRACTICE REF. PIP001  
ISSUED: 7/75/88  
REAFFIRMED: APRIL 2008  
PAGE 3 OF 4  
PIP-00-003

### **Appendix C – Example P&IDs**

C-1: Example P&ID 1

C-2: Example P&ID 2

C-3: Example Utility P&ID

Note: The examples shown on the sample P&IDs in this Appendix are not all-inclusive of the potential uses of implied components. The user must ensure that the cover sheets capture their piping/instrument requirements for their use of implied components. There are many more systems that may require a cover sheet explanation to show the implied components – pump seals, sampling systems, analyzer systems for example, as well as other types of level systems than those shown here.

Sample - No Commercial Use

**E-100**  
 REBOILER  
 DUTY: 49 MM BTU/HR  
 SURFACE AREA: 10,000 SQ FT  
 DES PRESS @ TEMP:  
 SHELL: 150 PSIG @ 200°F  
 TUBE: 150 PSIG @ 325°F  
 MATL (SHELL/TUBE): CS/304SS  
 TRIM (SHELL/TUBE): 1CS1S01/1CS1S02  
 INSULATION: HC

**T-100**  
 FRACTIONATING TOWER  
 SIZE: 6'-0" D x 43'-0" T/T  
 DES PRESS @ TEMP:  
 MATL: CS  
 TRIM: 1CS1S01  
 INSULATION: HC

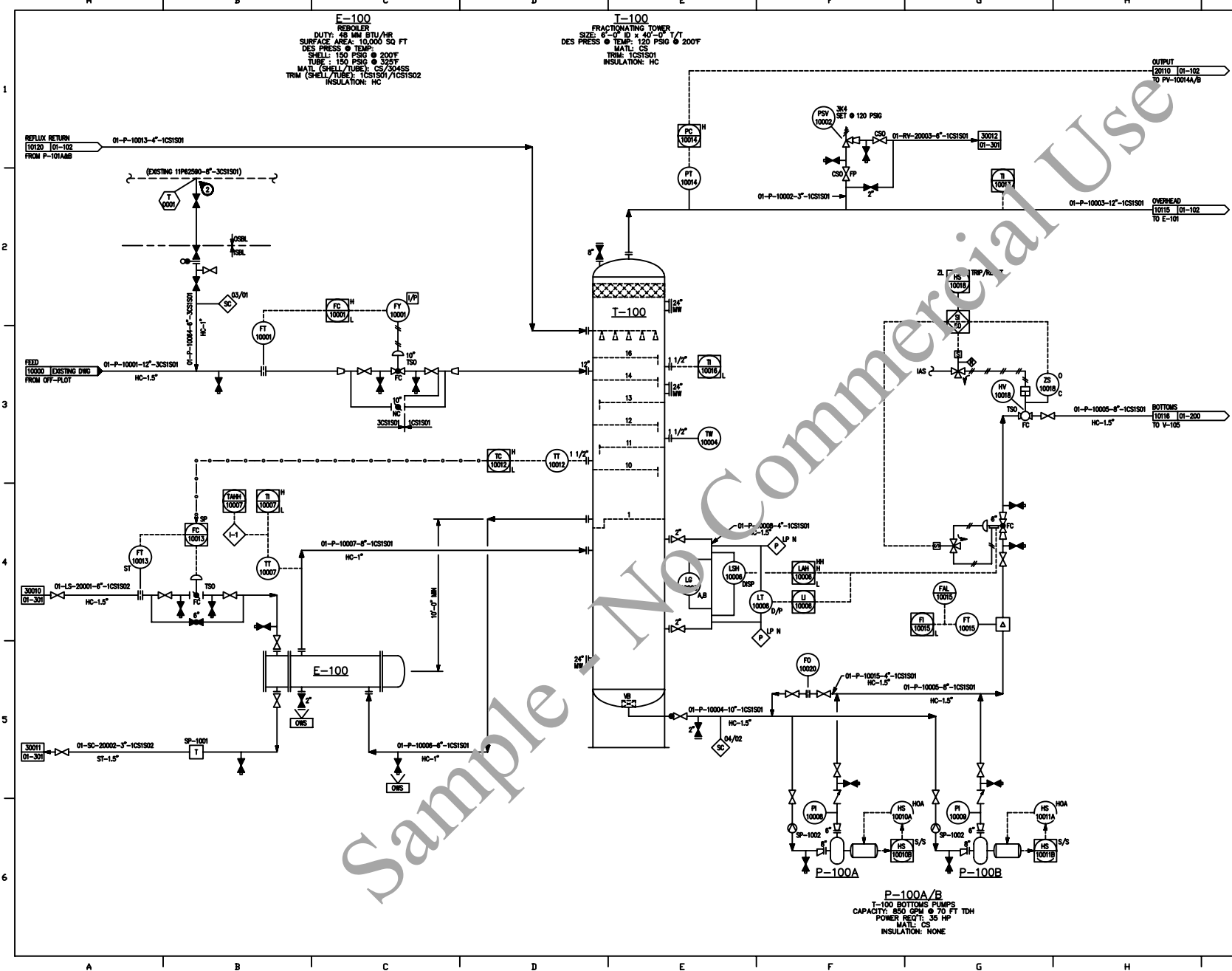

NOTES:  
 1. FOR NOTES, SYMBOLS AND ABBREVIATIONS, SEE "SYMBOLS AND NOMENCLATURE", PIP-00-001 THROUGH 003, AND "TYPICAL DETAILS WITH IMPLIED COMPONENTS", PIP-00-004.  
 2. CONNECT TO TOP OF LINE.

PROCESS INDUSTRY PRACTICES  
 PIPING AND INSTRUMENTATION DIAGRAM

EXAMPLE PAID 1  
 APPENDIX C

**PIP**  
 PRACTICE REF. PIP001  
 ISSUED: APRIL 2008  
 REAPPROVED:  
 PAGE 1 OF 3  
 PIP-01-101