



PistenBully 400

On its own or part of a fleet.

www.pistenbully.com

PistenBully[®]



A strong and dependable companion.

Technically top of its class. Extremely easy and comfortable to operate. Absolute precision. The PistenBully 400 possesses all the features which are essential for work on the roofs of the world. From its comfortable cockpit to its powerful yet economical engine, to its robust frame structure – the new companion has been designed to cater in the most effective way possible for the demands of the driver and the severe conditions of the mountains.



No finer place of work anywhere in the world.

As soon as you enter the cockpit, you feel on top of the world. The PistenBully 400 is impressive any time you look at it – whether for the first time or for the hundredth time. Our insistence on top quality design and our extensive experience have combined to create a place of work which is absolutely without equal. And the impression lasts!





Well thought out.

There is a large box underneath the passenger seat. This provides sufficient storage space for tool kits and much more besides.

Details that speak for themselves.

The extremely spacious cockpit has been built using Kässbohrer's tried and trusted hybrid construction method, is very stable and is ROPS certified in accordance with DIN 30770 and ÖN 9850. The large windscreen extends fully downwards and provides perfect all-round visibility. A pleasant low-noise working atmosphere is ensured by means of numerous sound insulation features in the floor pan, the cockpit ceiling and the external panelling. When the temperature falls below freezing, heat is provided to the floor area and the side windows by means of two separate heat exchangers equipped with blowers.



Everything clearly within view.

The PistenBully 400's control panel is neatly arranged and highly user friendly. All important functions can be grasped quickly, ensuring safe and efficient operation. The clear monitor provides access to all important information and enables the operator to understand quickly what is happening.



Driver friendly.

The ergonomically designed driver's seat is infinitely adjustable and allows the driver to carry out his work with comfort and without causing tiredness.



Precision steering.

The semi-circular steering wheel is infinitely adjustable within the horizontal plane and feels comfortable. The PistenBully can be driven effortlessly and the most important functions can be operated directly via the controls integrated in the steering wheel.



Straightforward operation.

All important functions have been integrated into the ergonomically designed joystick and can be easily accessed by the driver.

Robust running gear. For controlled power in the terrain.

The best running features for the best pushing capabilities. This optimally balanced vehicle ensures a pleasant driving experience and produces perfectly prepared pistes. Something for the PistenBully 400 driver to look forward to.



Foldable transport railing.

A major plus is the facility to safely transport DIN 30770 and ÖNORM 9850 trained personnel. When the (optional) transport railing is folded down, the PistenBully 400 offers a fully useable loading area which can accommodate weights of up to 1,500 kg.



Rear view.

The PistenBully 400's external mirrors are especially large and are electrically heated, guaranteeing a perfect view of the tracks and tiller.

Top performance across the board.



Comfortable.

The PistenBully 400's tensioning axle can be adjusted hydraulically. The hydraulic track tensioner ensures that the tracks have a long operational lifespan.



Drive performance.

The Cummins QSL 6 cylinder in line diesel engine with turbocharger and aftercooling, 370 hp and a maximum torque of 1519 Nm at 1500 rpm produces pure power on the slope. It is rated Euromot IIIA / EPA Tier 3.

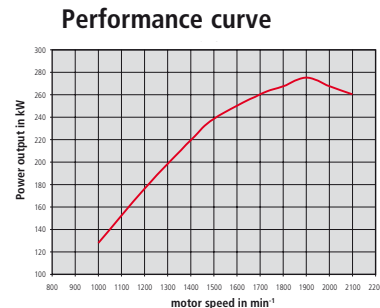
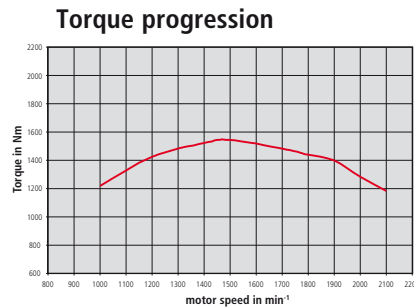

Perfect finishing.

The PistenBully 400's AlpineFlexTiller produces marvellous results in all snow conditions. Its overall weight is low, with the extension and tiller frames being particularly light. The finishing outrigger ensures perfect alignment to the engine compartment by means of the "windscreen wiper system" and the large protector unit prevents snow from finding its way onto the tiller or the finished parts of the slope. In addition, a large tiller pump ensures optimal rotational speed and perfect torque for the AlpineFlexTiller even in the most difficult operating conditions. The optional hydraulically foldable side flaps prevent the build up of side embankments and ensure a perfect transition in the case of overlapping grooming.

An illuminating experience.

The PistenBully 400's lighting concept is an all-round success. Two front headlamps and a twin searchlight are integrated into the roof of the driver's cab, ensuring clear long-range and working-area illumination. H3 SideFinder lights mounted on the left and right sides of the supporting frame ensure excellent illumination of the slope edges and the side wings of the clearing blade. Two H11 rear spotlights ensure a perfect view of the AlpineFlexTiller and the slope and there is also a service light in the engine compartment which ensures good illumination of the supporting frame area. As an option, it is also possible to have Xenon versions of the front and rear working area spotlights or to have two TreeLine lamps plus two additional Xenon working lights on the support handrail. The overall effect is illumination of the working area which is as good as daylight.

PistenBully 400 with standard lights

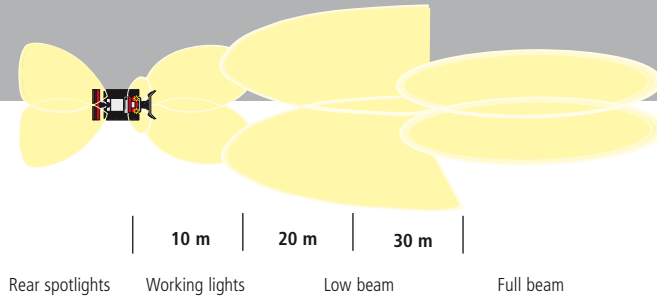

PistenBully 400 with Xenon lights

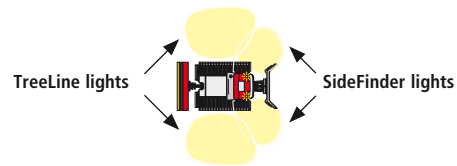
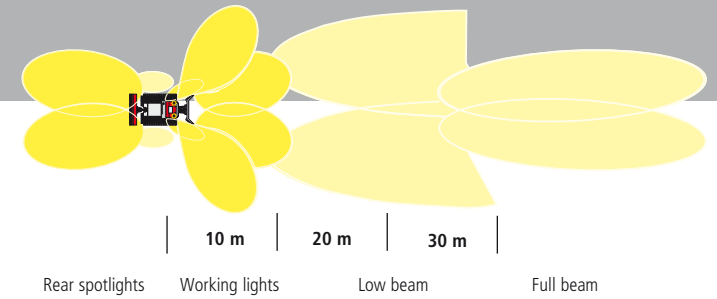

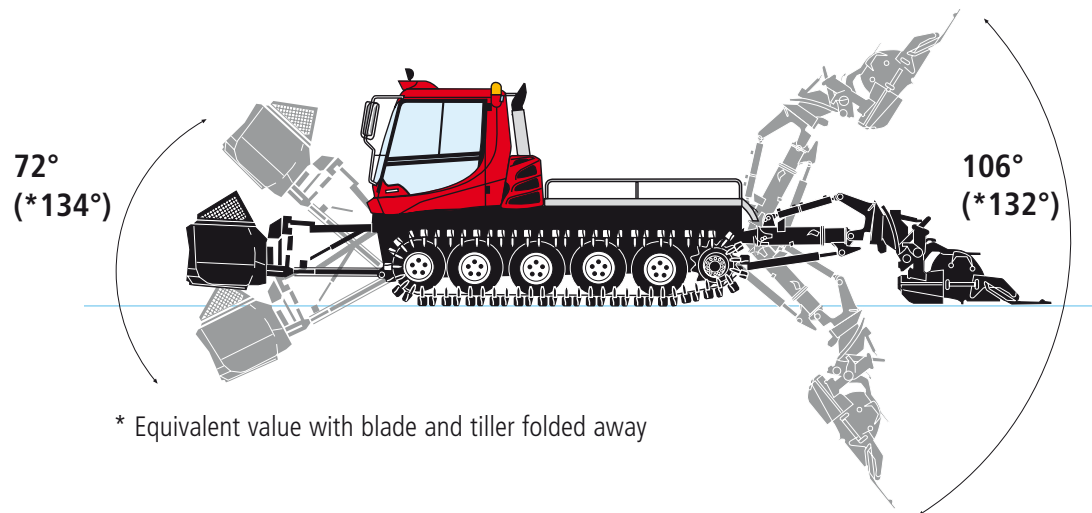

* Equivalent value with blade and tiller folded away

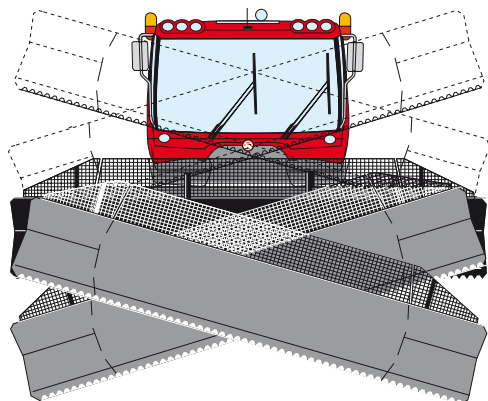

PistenBully 400 in the fun park. Options without limit.

Every season, expectations rise with regard to what makes a perfect fun park. Powerful and extremely versatile snow groomers are the order of the day. And the best way of meeting those expectations is with the PistenBully 400 *Park*. ParkFlexTiller, PipeMagician, Front Snow-blower, Snowbucket and ParkBlade. There are numerous accessories to help in laying out a fun park in a way which provides lots of variety and challenges. Thanks to the panoramic visibility from the cockpit, the driver has no difficulty in controlling the accessories with precision. The driver's seat can be swivelled about 20 degrees, allowing the driver to have a good view to the rear.





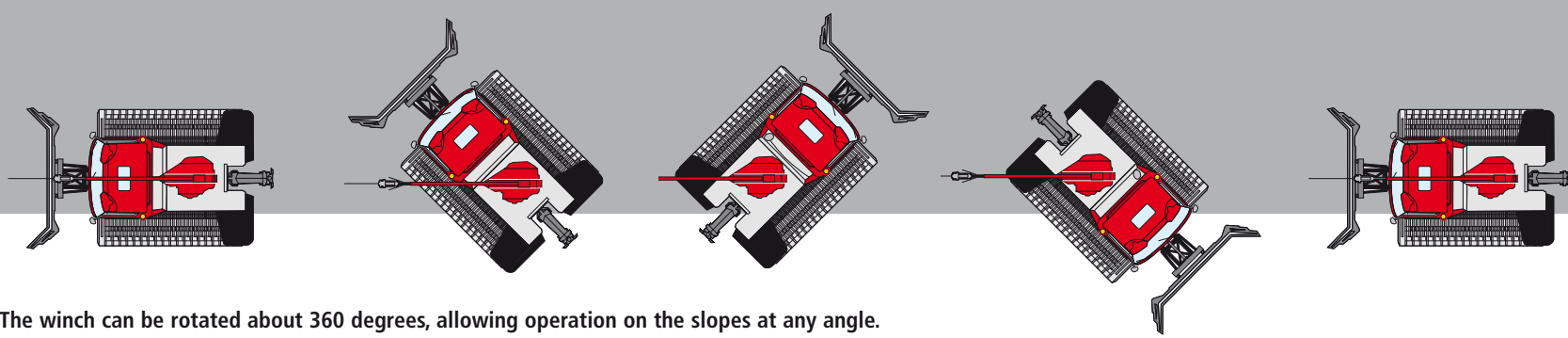

The winch can be rotated about 360 degrees, allowing operation on the slopes at any angle.

PistenBully 400 with winch. Safety guaranteed.



The maximum cable traction power of up to 4 tonnes provides high safety reserve levels. The Rope Failure Detector early warning system automatically monitors the rope and can detect wire and rope tears early on. When the winch arm is tilted and when the maximum usable rope length of 1,000 metres has been reached, an alarm sounds to alert the driver. Thanks to new glass production technology, there is no longer any need for additional protective windows on the winch machines. This guarantees optimal visibility. Other safety features include an electric rope traction monitoring system, an automatic winch winder control with differential sensors to monitor the condition of the ropes, and a winder and stop position indicator with built-in alarm to alert the driver in the event of a malfunction.



The all-round, carefree package.



The PistenBully service concept: with more than 130 service facilities and local representations worldwide, rapid support and spare parts supply are guaranteed 24 hours a day, 7 days a week, 52 weeks a year. What's more, we offer a service providing training, consultancy and shows, allowing exchange of experience, greater background knowledge and thus more independence for you. A partnership with the promise of success!



And those who know us also know that PistenBullys are not only low on service; they are also high on economy. In development, we have already tackled the need for outstanding performance, long lifetime and low ongoing costs. A PistenBully pays. Today, tomorrow and beyond.

Technical Data PistenBully 400 / PistenBully 400 Park / PistenBully 400 W

Dimensions		
Width without tracks	2.500 mm	98.4"
Over combined tracks	4,206 mm	165.6"
Over steel tracks	4,206 mm	165.6"
Over finisher and AlpineFlexTiller	5,500 mm	216.5"
Over foldable side flaps (optional)	6,400 mm	252.0"
Height above winch ready for operation	3,280 mm	129.1"
Height when driver's cabin tilted	3,250 mm	128.0"
Height above everything	2,830 mm	111.4"
Length with All-Way-Blade and AlpineFlexTiller	9,010 mm	354.7"
Ground clearance	350 mm	13.8"
Load area	2,120 x 1,920 mm (4.1 m ²)	83.5" x 75.6" (4.9 yd ²)
Engine		
Type	Cummins QSL 9	
No. of cylinders	6	
Displacement	8,9 l / 8,900 cm ³	
Power output (ECE)	272 kW (370 hp)	
Max. torque	1,519 Nm at 1,500 rpm	
Fuel consumption	from 19 l/h	
Fuel tank capacity	260 l	
Exhaust emissions standard	EUROMOT III A / EPA TIER 3	
Brakes		
	Using hydromatic transmission, with no mechanical wear	
	Two multidisk-holding brakes	
Electrics		
Voltage	24 volts	
Alternator	28 volts / 140 amps	
Batteries	2 x 12 volts / 135 Ah V3 SHD	
Cold start rating	900 A EN (50342)	

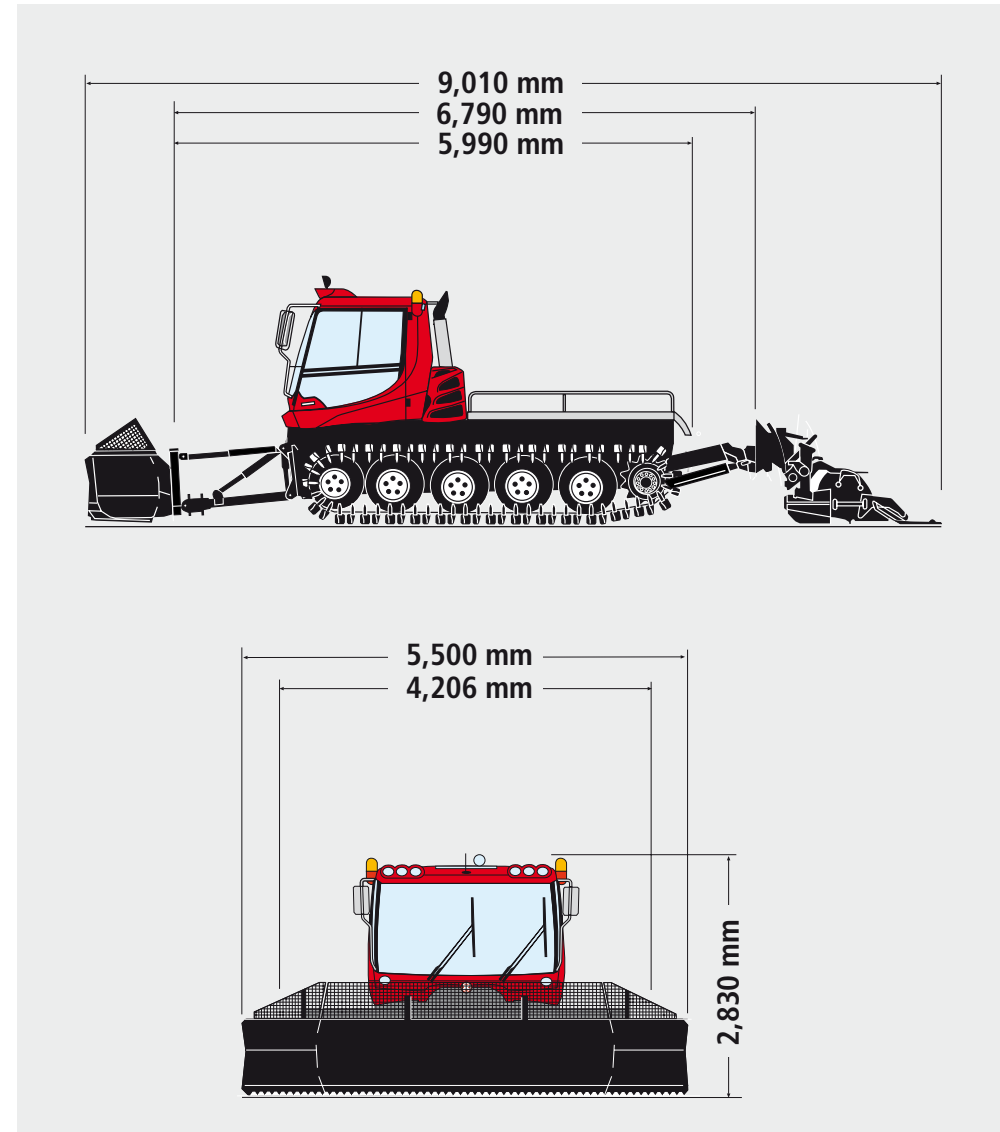

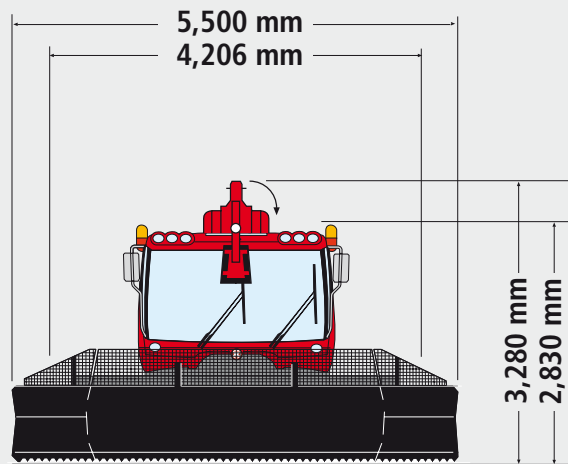
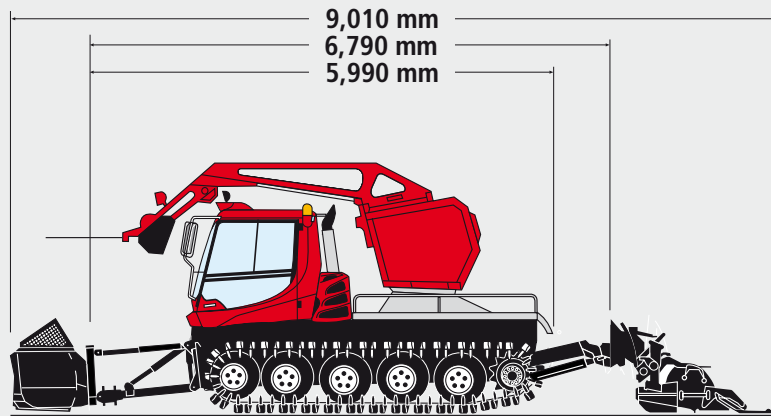

Technical Data PistenBully 400 / PistenBully 400 Park / PistenBully 400 W

	PistenBully 400 / PistenBully 400 Park	PistenBully 400 W
Weight		
Tare weight with combined tracks	7,340 kg /16,182 lbs	9,270 kg /20,437 lbs
Tare weight with steel tracks	8,020 kg /17,681 lbs	9,950 kg /21,936 lbs
Gross weight limit including attachments	11,800 kg /26,015 lbs	11,800 kg /26,015 lbs
Payload on platform without winch	1,500 kg /3,300 lbs	2,500 kg /5,510 lbs
Performance data		
Speed, infinitely variable	0–23 km/h /0–14 mp/h	–
Speed with winch in operation	–	0–17 km/h /0–11 mp/h, 3-stage
Speed with winch mounted	–	0–20 km/h /0–12 mp/h, 3-stage
Spec. ground pressure with combined tracks	0.052 kg/cm ² /0.74 psi	0.066 kg/cm ² /0.94 psi
Spec. ground pressure with steel tracks	0.057 kg/cm ² /0.81 psi	0.070 kg/cm ² /1.0 psi
Ø Ground coverage with AlpineFlexTiller	93,000 m ² /h /23 acres	93,000 m ² /h /23 acres
max. Ground coverage with AlpineFlexTiller	126,000 m ² /h /31,1 acres	110,000 m ² /h /27,2 acres
Winch superstructure		
Rope pull		40 kN (4,080 kp), 3-stage
Rope diameter		11 mm /0.43"
Rope length		1,050 m /1148,3 yd
Useable rope length		1,000 m /1093,6 yd
Rope breaking strength		129.8 kN (13,240 kp)
Drive rating at 40 kN rope pull		110 kW (150 hp)
Weight (winch, rope and superstructure)		1,900 kg /4,180 lbs
Attachments		
Front	All-Way-Blade, Front Snow-blower, SnowCutter, PipeMagician, Snowbucket, ParkBlade, Blade Loader	
Rear	AlpineFlexTiller, ParkFlexTiller, flexible smoothing board	

Kässbohrer Geländefahrzeug AG

Kässbohrerstraße 11, 88471 Laupheim

Phone: +49 (0) 73 92/9 00-0, Fax: +49 (0) 73 92/9 00-4 45

www.pistenbully.com, E-Mail: info@pistenbully.com

Austria

Gewerbestraße 173, 5431 Kuchl

Phone: +43 (0) 62 44/4 00 10, Fax: +43 (0) 62 44/40 01 11

www.pistenbully.at, E-Mail: office@pistenbully.at

Switzerland

Bruneggerstraße 45, 5103 Möriken

Phone: +41 (0) 62/8 87 70 50, Fax: +41 (0) 62/8 87 70 51

www.pistenbully.ch, E-Mail: info@pistenbully.ch

Italy

Via Galileo Galilei, 32, 39100 Bolzano

Phone: +39 04 71/93 30 27, Fax: +39 04 71/93 29 75

www.pistenbully.it, E-Mail: info@pistenbully.it

France

Kässbohrer E.S.E.

Portes de Tarentaise, 73790 Tours en Savoie

Phone: +33 (0) 4 79/10 46 10, Fax: +33 (0) 4 79/10 46 40

www.pistenbully.fr, E-Mail: info@pistenbully.fr

USA

Kässbohrer All Terrain Vehicles Inc.

750 A South Rock Boulevard, Reno Nevada 89502

Phone: +1 (0) 7 75/8 57 50 00, Fax: +1 (0) 7 75/8 57 50 10

www.pistenbullyusa.com, E-Mail: info@katvpb.com



KÄSSBOHRER GELÄNDEFahrZEUG AG

About the details in this catalogue: Changes may have been made to the product after the time of this brochure going to press. The images also contain accessories and special equipment that are not supplied as standard. Slight variations in colour may occur as a result of the printing process. Any statements regarding the statutory, legal and tax regulations and their effects are only valid for the Federal Republic of Germany. For the definitive latest version, please ask your contact at Kässbohrer Geländefahrzeug AG. Printed in Germany on chlorine-free bleached paper. · 080 · 4/2008 · e1 · WA · 3.000