

## PLASTIC PROCESSING TECHNIQUE

Plastic processing can be defined as the process of converting the plastics raw material into semi-finished products.

Ex: Buckets, Automobile Parts, Crates, Tanks, Pipes, Bottles, Carry bags, Ropes, Profiles etc.

Classification of processing methods

1. Primary Processing Methods: Injection, Extrusion, Blow, Compression and transfer moulding.
2. Secondary Processing Methods: Roto, Thermoforming, Coating, Casting, Fabrication and Calendaring etc.
3. Tertiary Processing Methods: Cutting, Drilling, Welding and Bending etc.

Fundamentals of Processing

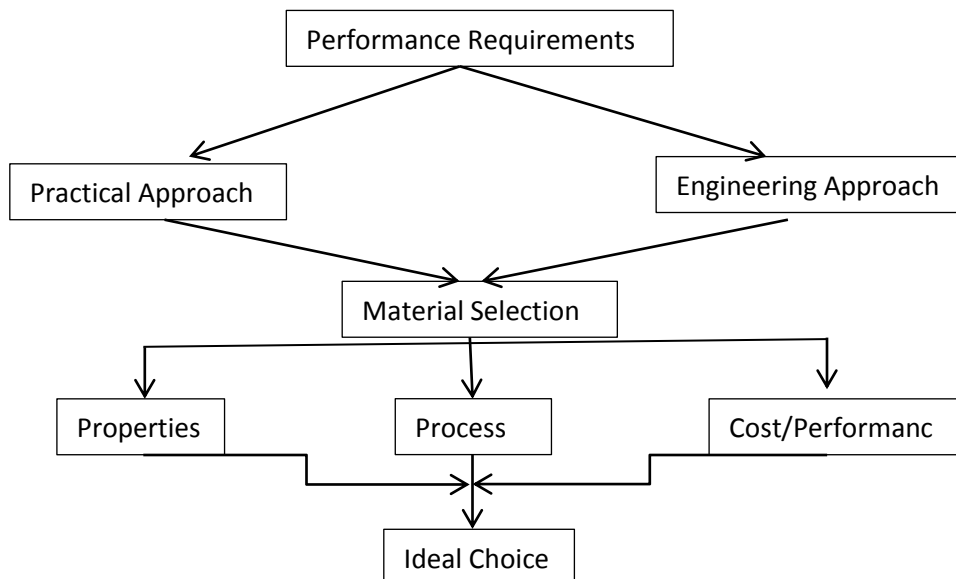

Processability:

Processability is generally the ease or difficulty with which a plastic can be handled during its fabrication into film, moulded products, pipe, profile etc.

A plastic with good processability possesses the properties necessary to make it easy to process the plastics into desired shapes. The main characteristics or the properties which determine a plastic's processability are molecular weight, uniformity, additive type, content and plastic feed rates.

Primary Processing Technology Types:

1. **Injection Moulding:** Thermoplastic or Thermoset plasticated at control temperature inside the screw pump (a combination of screw & barrel), then forced under pressure through a nozzle into sprue, runners, gates and cavities of mould.  
Types of products: Spools, bobbin, bottle caps, automotive parts, gem clips, crates, buckets etc.

Types of Injection moulding machine:

1. Hand injection moulding:
2. Semi-auto (Plunger type) Injection moulding:
3. Fully-auto (Screw type) Injection moulding:
4. Advanced injection moulding:

1. *Hand Injection moulding*: vertical machine consists of Barrel, Plunger, Band Heaters along with energy regulator, Rack & Pinion system for Injecting the material by the plunger, a torpedo and nozzle.

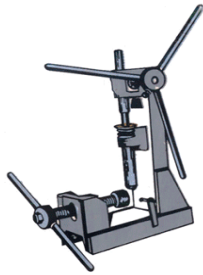

(Machine)



(Product)

2. *Semi auto injection moulding (Plunger type)*

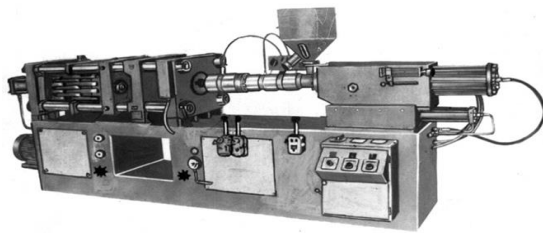

(Horizontal Machine)



(Vertical Machine)



(Product)



(Product)

3. *Fully auto injection moulding: (Screw type)*





(Products)

4. *Advanced injection moulding :*



(Machine)



(Products)

2. **Blow Moulding:** An extruded parison tube of heated thermoplastics is positioned between two halves of an open split mould and inflated against the sides of the closed mould using air pressure.  
 Types of Products: Bottles, Containers, Air ducts, Panels, Portable toilets, Arm rests, tanks, gas tanks.

Types of Blow moulding machine:

1. Extrusion Blow moulding
2. Injection Blow moulding
3. Stretch Blow moulding

1. *Extrusion Blow moulding:* In extrusion blow molding (EBM), plastic is melted and extruded into a hollow tube (a parison). This parison is then captured by closing it into a cooled metal mold. Air is then blown into the parison, inflating it into the shape of the hollow bottle, container or part. After the plastic has cooled sufficiently, the mold is opened and the part is ejected.

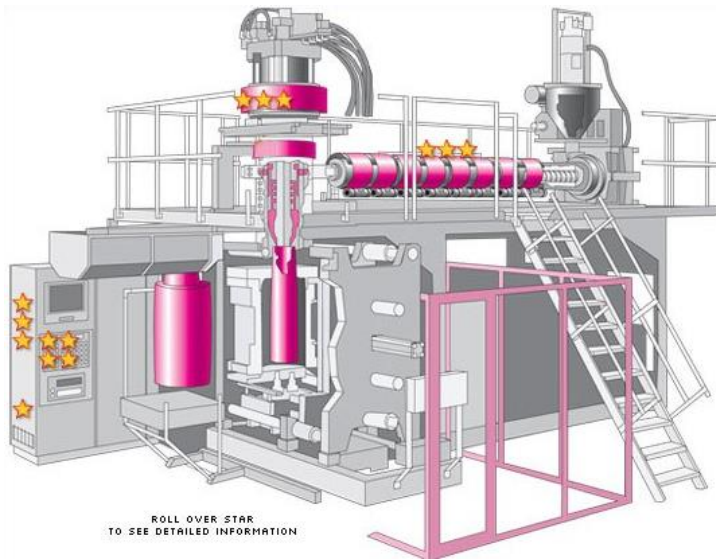

(Machine)



(Product)

2. *Injection Blow moulding*: The process of injection blow molding (IBM) is used for the production of hollow glass and plastic objects in large quantities. The blow molding process begins with melting down the plastic and forming it into a parison or in the case of injection. The parison is a tube-like piece of plastic with a hole in one end through which compressed air can pass.

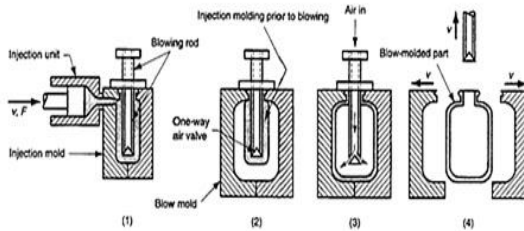

(Process)



(Machine)



(Product)

3. *Stretch Blow moulding*: In the stretch blow molding (SBM) process, the plastic is first molded into a "preform" using the injection molding process. The preforms are heated (typically using infrared heaters) above their glass transition temperature, then blown using high pressure air into bottles using metal blow molds. The preform is always stretched with a core rod as part of the process. In the single-stage process both preform manufacture and bottle blowing are performed in the same machine.

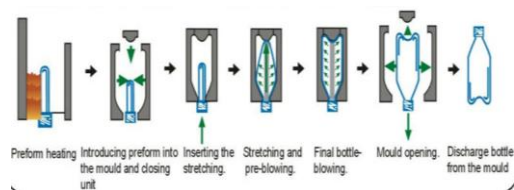

(Process)



(Machine)

4. **Extrusion Process:** It is continues Process. Thermoplastic moulding compound/material is fed from a hopper to a screw pump where it is to plasticated then pumped out through the shaping orifice (die) to achieve desired cross section.

5. Types of products: Films, Pipes, Strapping, Sheets, Multilayer films, Profiles etc.

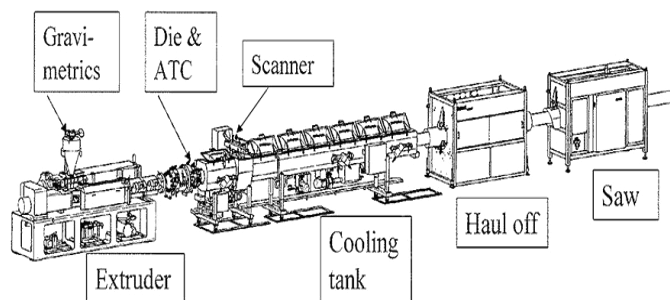

(Machine: Pipes)

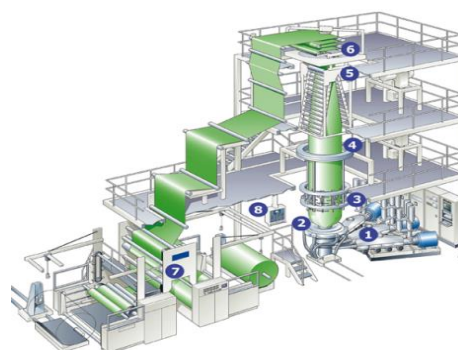

(Machine: Films)



(Product)



(Product)

6. **Compression Moulding:** Thermoset compound, usually preformed, is positioned in a heated mould cavity; the mould is closed with the application of heat and pressure the material flows and fills the mould cavity. Heat completes polymerization and identification the part of ejected.

Types of Products: Plugs, sockets, handles, Engine Casing switches, cistern etc.

## Compression Moulding

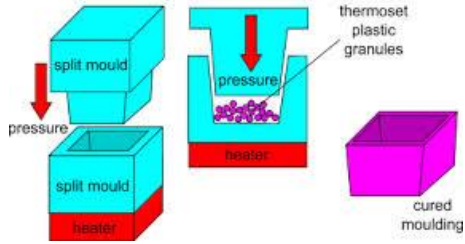

- 7. Transfer Moulding:** Thermoset moulding compound is fed into transfer chamber where it is then heated to plasticated; it is then fed by a plunger through sprue, runners, and gates into a closed mould where it cures; mould is opened and part ejected.

Types of Products: Plugs, Sockets, Handles, Engine Casing Switches, Cistern etc.

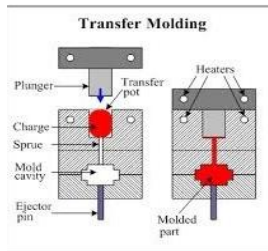

(Process)



(Product)

## Secondary Processing Technology Types:

- 1. Rotation Moulding:** A predetermined amount of powdered thermoplastic material is poured into mould; mould is closed, heated, and rotated in the axis of two planes until contents have fused to the inner walls of mould; mould is then opened and part is removed.



(Machine)

ers, Medical Ca



(Product)

2. **Thermoforming Moulding:** Heat-softened thermoplastic sheet is positioned over male or female mould; air is evacuated between sheet and mould, forcing sheet to conform to contour of mould.

Types of Products: House wares, Ducts, Toys, Refrigerator panels, Boat windshields etc.



(Machine)

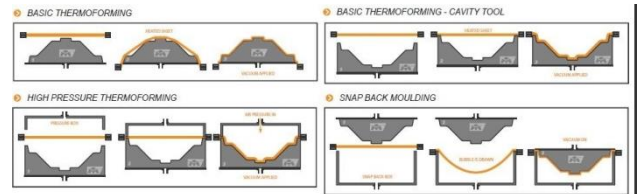

(Process)



(Product)

3. **Calendering:** Dough-consistent thermoplastic mass is formed into a sheet of uniform thickness by passing it through and over a series of heated or cooled rolls. Calenders are also utilized to apply plastic covering to the backs of other materials.

Types of Products: Luggage, Rain wear, Tank lining, Credit cards, Trays, Helmet liner etc.

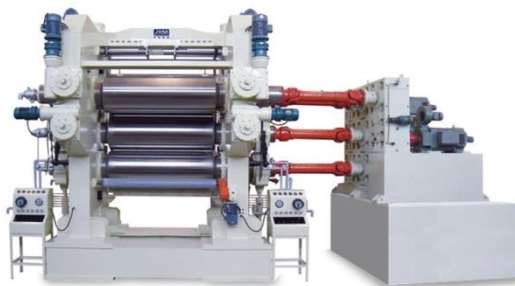

(Machine)

4. **Coating:** Process methods both thermoplastics and thermosets are widely used in coating of numerous materials, roller coating is similar to calendaring process. Spread coating employs blade is front of roller to position resin on material.

Types of Products: Polyethylene coating, Outdoor fencing, Chemical tanks, Plastics racks, Dish washers etc.



(PVC coating Machine)

5. **Casting:** Liquid resin which is generally thermoset except for acrylics is poured into a heated mould without pressure, cured, and taken from the mould. Cast thermoplastic films are produced via building up the material against a highly polished supporting surface.

Types of products: Rain boots, Shoes, Hollow toys, Balls, large pipes and tubes etc.

6. **Fabrication:** Plastic fabrication methods that are able to strengthen plastics. Compounding or Blending is the process of combining two or more types of plastic materials by melting, molding, and cooling them into different shapes.

Types of Products:

