

---

# Playground Safety & Maintenance



- Jodi L. Traas
  - Certified Playground Safety Inspector
  - Senior Risk Management Consultant
  - Community Insurance Corporation
-

---

# U.S. Organizations Concerned with Playground Safety

- CPSC – US Consumer Products Safety commission
    - ❑ Handbook for Public Playground Safety, Pub. No. 325 (2008)
    - ❑ Handbook for Home Playground Safety, Pub. No 324 (2005)
    - ❑ Only Federal Agency that has authority to have equipment removed
    - ❑ [www.cpsc.gov](http://www.cpsc.gov)
    - ❑ **Federal Guideline (1981-2008)**
  - ASTM – American Society for Testing & Materials
    - ❑ **National Voluntary Standard F1487-11 (2011)**
    - ❑ [www.astm.org](http://www.astm.org)
    - ❑ Standard Consumer Safety Performance Specification for Playground Equipment for Public Use
    - ❑ World's largest voluntary standard
-

# Other Relevant ASTM Standards

- F2373 – Standard Consumer Safety Performance Specification for Public Use Play Equipment for Children 6 months through 23 months (2005)
- F1292 – Method to Test Impact Attenuation of Safety Surfacing for Playgrounds
- F1951 – Method to Test Accessibility of Safety Surfacing for Playgrounds
- F2049 – Guide for fencing/Barriers for Playgrounds (Use this if decide to fence)
- F2075 – Engineered Wood Fiber Safety Surfacing (15 different manufacturers)

---

# U.S. Organizations Concerned with Playground Safety

- **IPEMA – International Playground Equipment Manufacturers Association**
    - ❑ New designs are sent to IPEMA
    - ❑ Piece of equipment is IPEMA Certified not a manufacturer
    - ❑ [www.ipema.org](http://www.ipema.org)
  - **NPCA – National Playground Contractor's Association**
    - ❑ [www.playground-contractors.org/](http://www.playground-contractors.org/)
    - ❑ International organization
-



---

# U.S. Organizations Concerned with Playground Safety

- NPSI – National Playground Safety Institute
    - [www.nrpa.org](http://www.nrpa.org)
    - Certified Playground Safety Inspector Course & Certification
  - NPPS - National Program for Playground Safety
    - [www.uni.edu/playground/](http://www.uni.edu/playground/)
    - Videotapes, newsletters and a SAFE Playground Supervision Kit
    - [www.playgroundsafety.org](http://www.playgroundsafety.org)
-

---

# Significant Revisions for CPSC 2008

- Equipment guidelines for toddlers, guidelines for track rides and log rolls, exit zone requirements for slides
  - Critical height table revised, suggestions for surfacing over asphalt added
  - Suggestions on sun exposure added
  - Editorial changes to make the handbook easier to understand and use
-

---

# U.S. Law

- Is there a national playground safety law? NO
  - WI enforces playground safety criteria as a “Standard of Care”
  - All new or rebuilt playgrounds are subject to the ADAAG (American with Disabilities Act Accessibility Guidelines), ADA/ABA
  - Installation Procedures
-

---

# Additional Information

- Magazine Today's Playground  
[www.todaysplayground.com](http://www.todaysplayground.com)  
\$30/year
- Wis. Stats. 895.52,  
Recreational Use Statute



# Wisconsin's Playground Safety Report Card

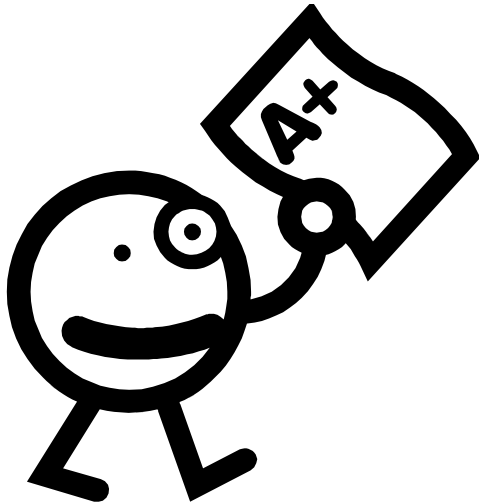

- 2000 = C-
  - 2004 = B+
  - Park Grade
    - 2000 = D+
    - 2004 = B+
  - School Grade
    - 2000 = C-
    - 2004 = B+
- UNITED STATES = C+

---

# U.S. Law

- Is there a national playground safety law? NO
  - WI enforces playground safety criteria as a “Standard of Care”
  - All new or rebuilt playgrounds are subject to the ADAAG (American with Disabilities Act Accessibility Guidelines)
-

# ADA Accessibility Guidelines (ADAAG)

- Federal Register October 2000
- <http://www.access-board.gov/ada-aba/final.cfm>
- Approach, Enter & Use
- Minimum Number of accessible play components both ground level and elevated play components
- Firm, stable & slip resistant accessible route (60-inch pathway)
- IPEMA Checklist for Access





# NEISS

- National Electronic Injury Surveillance System
- CPSC has operated a statistically valid injury surveillance and follow-back system for 30 years. It has become an important public health research tool.



---

# How often is a Child Injured on a Playground in America?

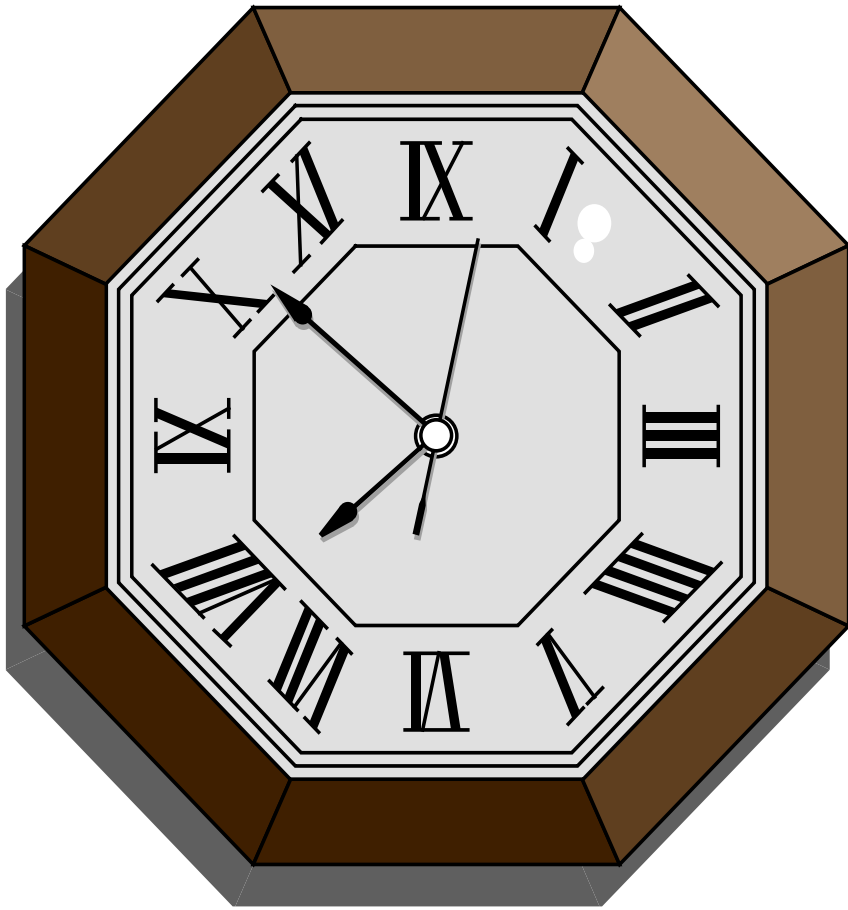

- One every 2 ½ minutes

# Injury Pyramid



- Death
- Strangulation & Brain Damage
- Physical Paralysis/Organ Loss
- Amputation/Blindness
- Fractures & Sever Burns
- Serious Laceration
- Sprains & Dislocations
- Simple Bruises, Cuts and Scratches
  - Greater frequency of injuries, then the severity increases!
  - Playground injury every 2.5 minutes

---

# Public Playgrounds vs. Home Playgrounds



- Nearly 76% of all injuries occurred on public playgrounds (45% in schools)
  - While 70% of deaths occurred on home playgrounds
  - Percentage of deaths greater for boys (62%)
-

# Causes of Public Playground Injuries



- 44% - Equipment Use & Supervision
- 36% - Poor Maintenance
- 10% - Improper Equipment
- 6% - Poor Installation
- 4% - Poor Layout

---

# Playground Layout

- Accessibility
- Age Separation
- Conflicting Activities
- Sight Lines
- Signage and/or Labeling
- Supervision
- **Sun Exposure:** Exposed bare metal slides, platforms, steps and surfacing – provide warnings or located out of the sun

Exposure during most intense part of the day (10-2)

Consider shading or providing shaded areas nearby

---

---

# Ages of Those Injured on Public Playgrounds



- ❑  $<2 = 3\%$
- ❑  $2-4 = 27\%$  (most at risk for life threatening injuries)
- ❑  $5-9 = 56\%$
- ❑  $10-12 = 12\%$
- ❑  $13-14 = 2\%$



# Falls are Cause of Most Injuries

- 79% of all playground injuries are Falls
- Falls are the MOST COMMON cause of injury on PUBLIC Playgrounds
  - 68% are falls to surface
  - 10% are falls to other parts of the equipment
  - 1 % are falls to unknown



# Causes of Playground Injuries

- 11% Impact
  - ❑ 8% impact with stationary equipment
  - ❑ 3% impact with moving equipment
- 10% Miscellaneous
  - ❑ Generally contact with crush points and sharp edges



# Major Cause of Death and Seriously Debilitating Injury

- ENTANGLEMENT of clothing, strings or ropes (most common cause of fatalities)
- FALLS to hard underlying surfaces
- HEAD ENTRAPMENT in equipment openings
- STRIKE IMPACT by moving swings or by tipped/loose equipment
- Strangulation = 30 seconds unconscious
- 2 year old dies in 3 minutes with 3 pounds of pressure



# Not Recommended for Public Playgrounds

- Swinging Gates
- Trapeze Bar
- Swinging Exercise Rings
- Animal Swings (Ordered Removed from Public Playgrounds by 1995)
- Trampolines
- Giant Stride





# Age Designation

- All playground equipment is broken down into three age categories
- Toddler 6 Months - 23 Months Old
- Pre-School Age Children 2-5 Year Olds
- School Age Children 5-12 Year Olds



---

## Tot Lots – Following are not recommended for Preschool-Age Children (2-5 yrs. old)



- Free-Standing Flexible Climbers (Cargo Net Type)
  - Track rides
  - Vertical sliding poles
  - Horizontal Ladders (4 yrs and older)
-

# Tot Lots – Following are not recommended for Preschool-Age Children (2-5 yrs. Old)



- Free standing arch climbers
- Chain/cable walks
- Fulcrum seesaws
- Log rolls



# Other Hazards



- Crush/Shearing Points (seesaw)
- Tripping Hazards (anchoring devices and containment walls)
- Strangulation hazard with Playground Cargo Nets ((when Perimeter of the net openings are between 17-28 inches (sum of the length of the four sides)) CPSC #5065)
- Burns on hot metal playground equipment (slides) 2nd -3rd degree burns CPSC #5036

# Other Hazards

- Wear bike helmets on bicycles - Not on playgrounds (strangulation hazard) CPSC #5121
- Drawstrings on jackets/sweatshirts - No drawstrings on hoods or around the neck CPSC #5094 (scarves/mittens too)
- Waist/ bottom no more than 3 inches (remember: car and bus doors)
- Lead Paint (prior to 1978) CPSC Recommendations October 1996
- Ropes not secured on both ends
- Insects



# Space Net





---

# Soccer Goals Anchored



# Use Zones



- An area under and around the equipment where protective surfacing is required.
- Stationary equipment: a minimum of 6 feet in all directions
- Swings – End of swing structure – 72”;  
Front-to-rear use zone where swing motion occurs is 2X from the beam, front and rear)
- Bucket Seats – $W$ =vertical distance from top of sitting surface to the pivot point.  
2W from the beam, front and rear



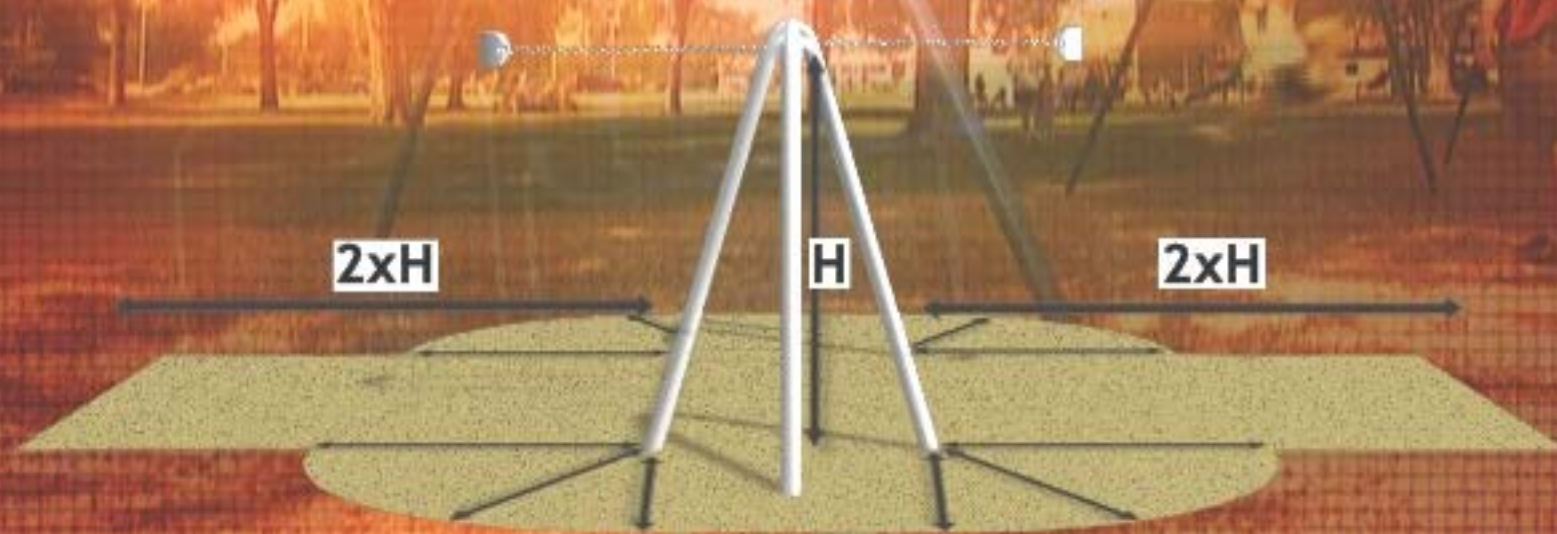
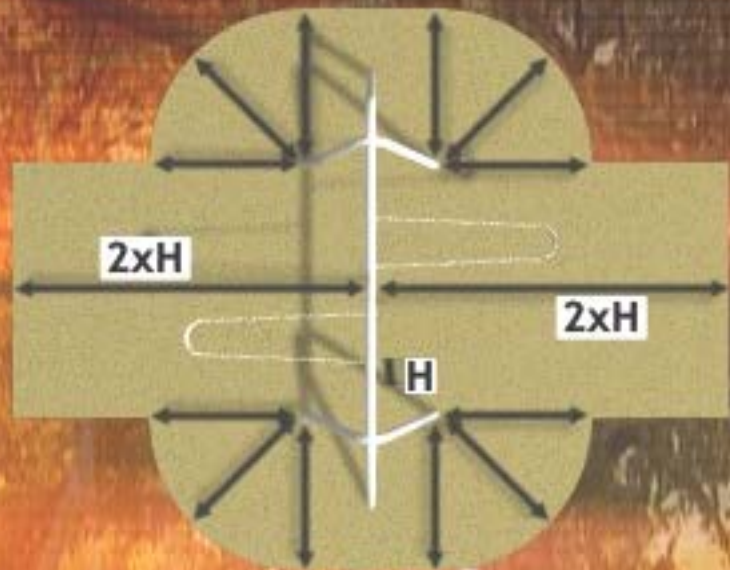



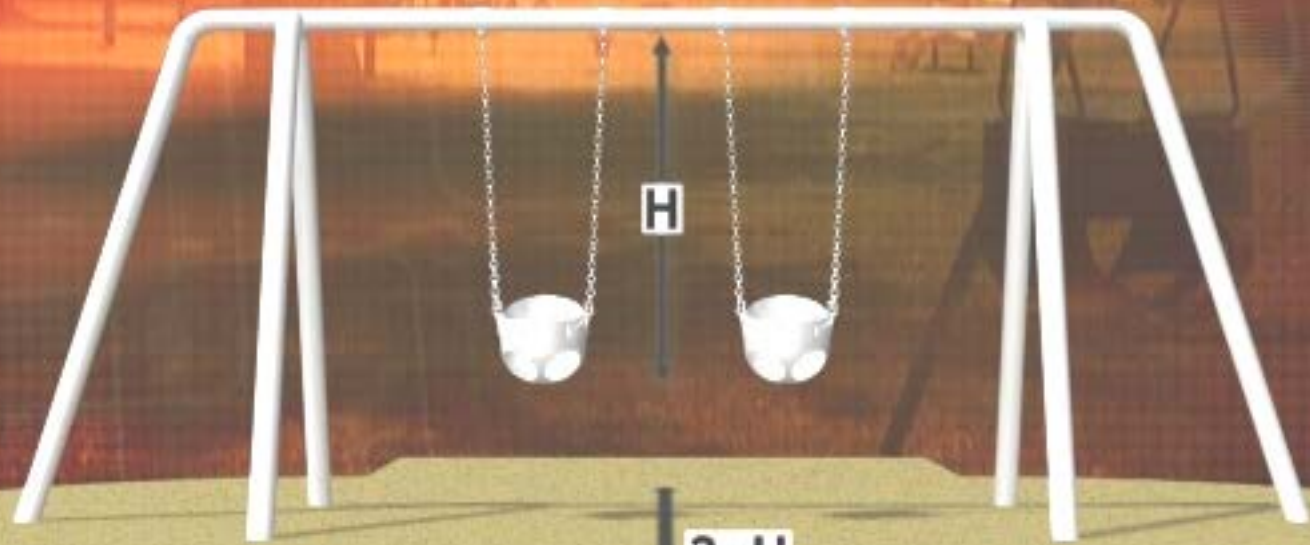
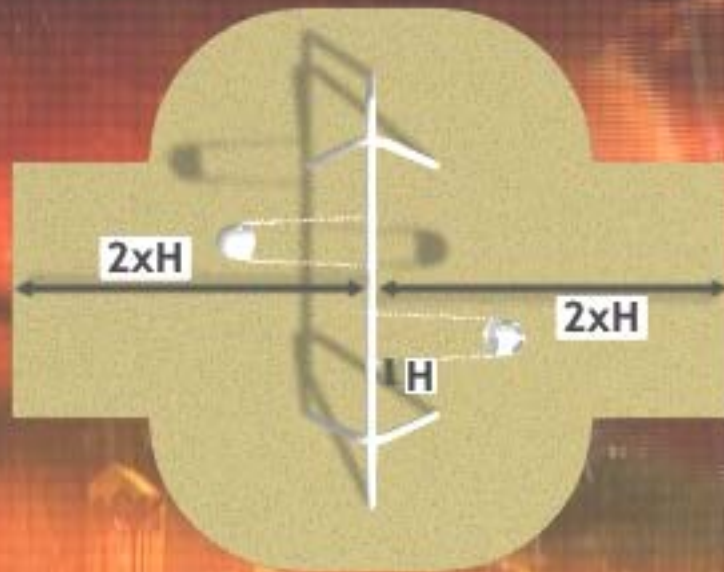

$2xH$



# Use Zones



# Use Zones

- Free Standing or Attached Slides
- X=highest point of the sliding surface
- 72” is the minimum depth of this zone
- 96” is the maximum depth of this zone





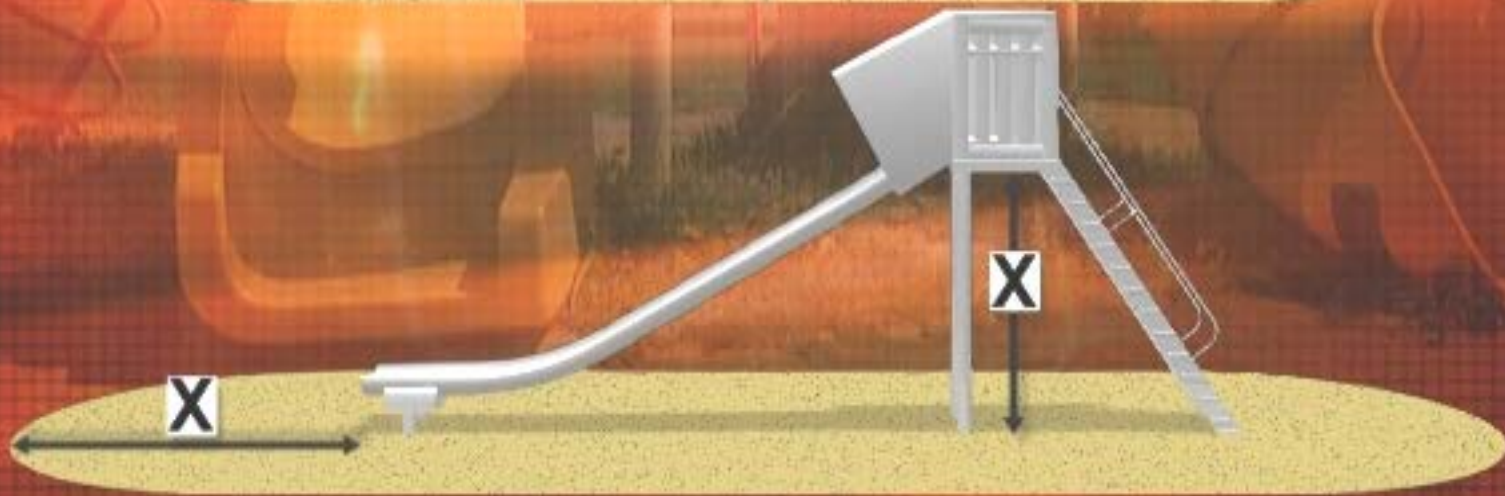
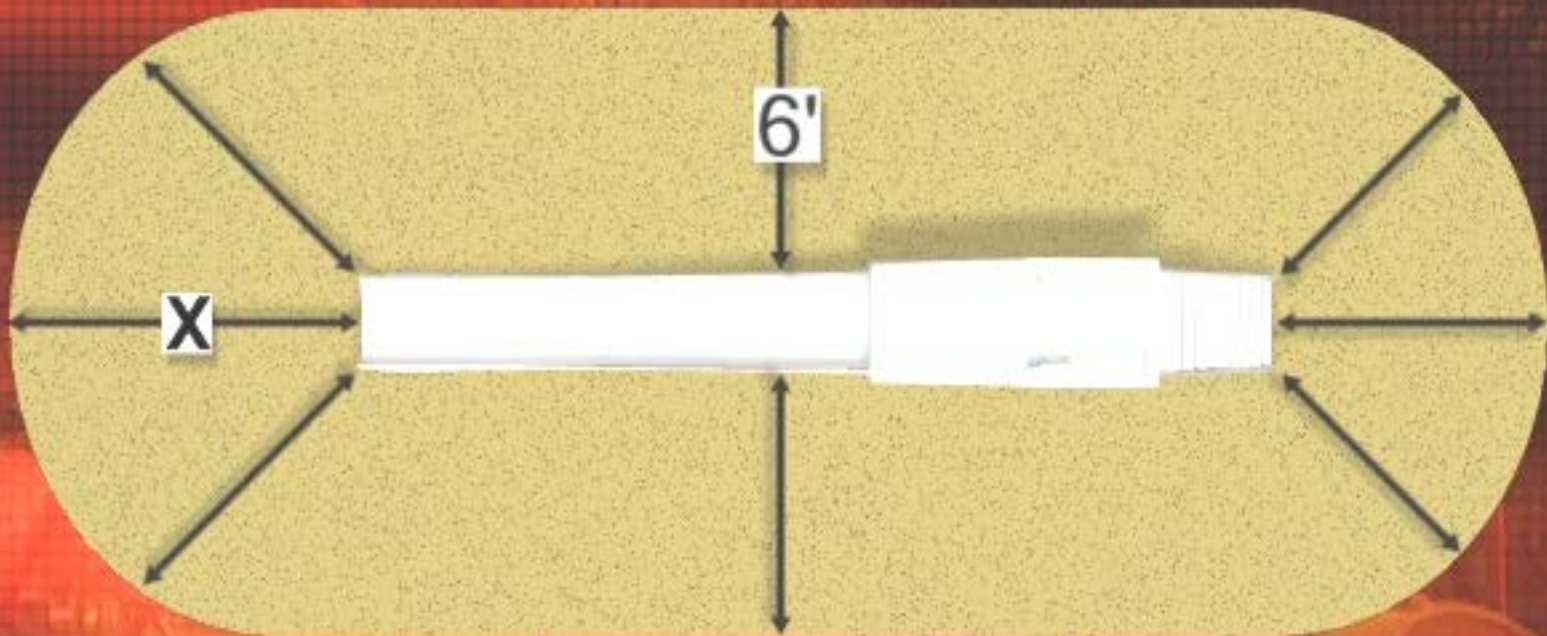

# Various Surfacing Materials-ASTM F1292

## Loose Fill

- **Wood Mulch (not CCA treated - weekly rake)**
- **Wood Chips**
- **Engineered Wood Fibers**
- **Sand (weekly rake so soft)**
- **Pea Gravel**
- **Shredded Tires**

## Unitary Materials

- **Rubber Mats, rubber tiles and poured rubber**
- **See CPSC Table**



# Fall Height

- This height can be considered as an approximation of the fall height below which a life-threatening head injury would not be expected to occur. Manufacturers and installers of playground protective surfacing should provide the critical height rating of their materials.
- This rating should be greater than or equal to the fall height of the highest piece of equipment on the playground. The fall height of a piece of equipment is the distance between the highest designated play surface on a piece of equipment and the protective surface beneath it.

## Table 2 – Minimum Compressed Loose-fill surfacing depths

Inches of	Loose-Fill Material	Protects to Fall Height (Feet)
6	Shredded/ recycled rubber	10
9	Sand	4
9	Pea Gravel	5
9	Wood Mulch (non-CCA)	7
9	Wood Chips	10



# Installation Layers

- Layer 1: Hard surface
- Layer 2: 3-6 inches of loose fill (gravel for drainage)
- Layer 3: Geotextile Cloth
- Layer 4: Loose-fill surfacing material
- Layer 5: Impact mats under swings
- Snow & Ice?
- See Figure 1 (CPSC)  
Page 11





# Tripping Hazard





# Wood Structures

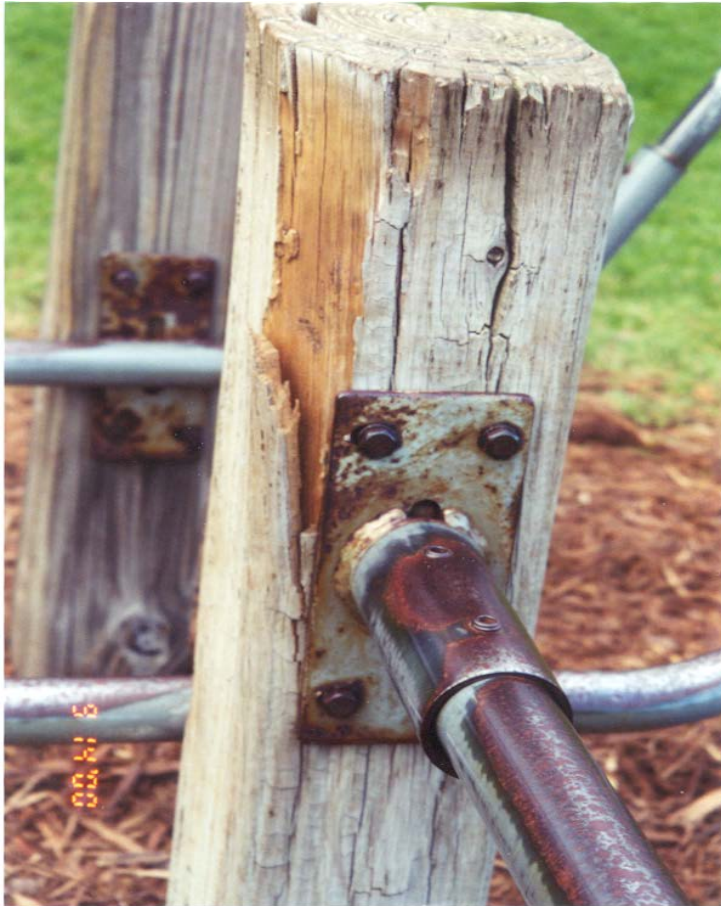

- Smooth & free from splinters and decay
- Corners, metal and wood, should be rounded.
- Creosote, pentachlorophenol & tributyl tin oxide are too toxic or irritating and should not be used.
- Metal equipment should not be rusted
- Rusted metal has a reduced tensile strength. The structural integrity of those parts will be compromised if rust is allowed to take over.

# Chromated Copper Arsenate (CCA)

- Wood may be CCA pressure treated wood. Protects against rotting due to insects and other microbial agents.
- CPSC & EPA phasing out CCA treated wood. CPSC Status Report (Dec 2003) enclosed.
- Disposal of CCA addressed via the Consumer Awareness Program (CAP).
- Never burn CCA wood in open fires, stoves, fireplaces or residential boilers. See [www.epa.gov/pesticides/factsheets/chemicals/1file.htm](http://www.epa.gov/pesticides/factsheets/chemicals/1file.htm)
- Chemical used until December 2003



# Head Entrapments – Completely Bounded Openings



- A child's head may become entrapped if the child enters an opening either feet first or head first.
- Test completely bounded openings between 3.5" & 9"
- Except where the ground serves as the opening's lower boundary
- Especially equipment installed before 1991

# Head Entrapment Testing

- Users at risk: Pre-school Age
- If the Torso Probe can be inserted in the opening, then use the Head Probe. Head probe dimension is based on the 95<sup>th</sup> percentile five-year old (chin to the back of the head)
- When the head probe cannot be inserted through the opening – the opening is considered a head entrapment
- Head & Torso Probes must be inserted at least 4”





# Head Entrapment - Slide



# Head Entrapment





# Completely Bounded Nonrigid Openings

- Flexible openings of bucket seats should be tested with the torso probe using 50 lbs. force.
- 50 lbs. force is needed to test non-rigid completely bounded openings.



# Head/Neck Entrapments – Partially Bounded Openings



- Use the Fish Probe Template
- Dimensions are based on the anthropometrics of 2 and 5 year old children.
- The opening is NOT a neck entrapment if the “A” portion of the wedge or fish probe does not touch the sides before hitting the bottom.
- If the “A” portion touches both sides than enter the “B” portion. If “B” portion of the wedge (or “fish”) probe can be fully inserted it is a potential neck entrapment.
- Angles should not be greater than 55 degrees unless one side is horizontal or below horizontal.



# Protrusions & Projections



- Protrusions/Projection
- 1/4 inch laceration
- 3/4 inch – eye socket
- 1.5 inch – impaling hazard
- Projection
- 1/8 inch – swings/slides
- No more than 2 bolt threads exposed beyond the nut.

# Pinch, Crush & Shear



- **3/16 “ dowel - roller slides**
- **5/16” dowel - merry-go-round**
- **5/8 inch – Pinch, crush & shear of moving equipment**



# Entanglement:

The act of twisting together or entwining into a confusing mass; to snarl



---

# Entanglement Hazard Protrusion

- Top part of the compound projection has a vertical projection that is greater than 1/8" high.
- Entanglements two greatest hazards: top rail of swing beams and gaps at top of slide bed.



# Entanglement





# Loose Ropes



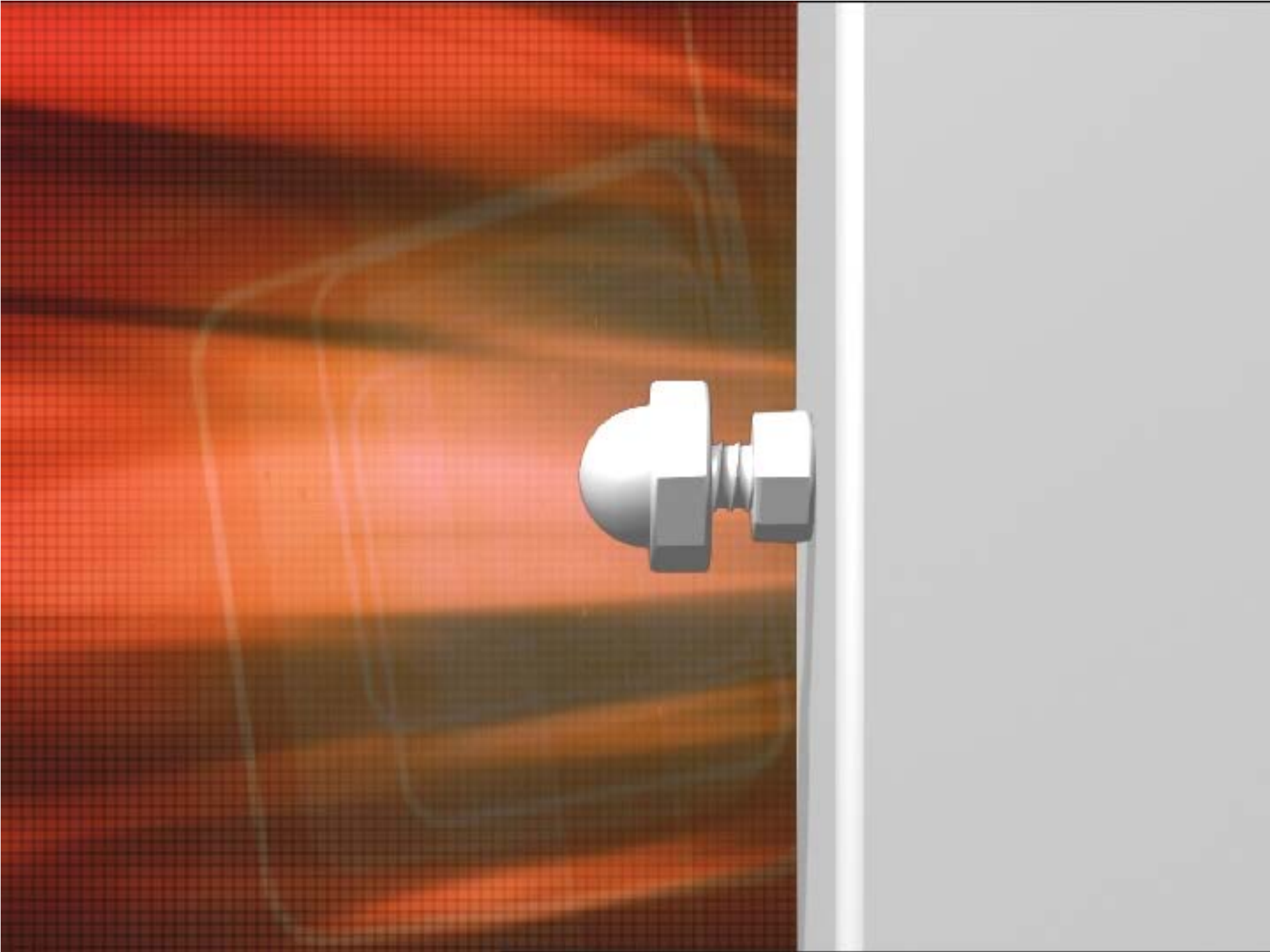

# Swings



- Animal Swings Removed
- Two swings per bay
- Tot swings separate bay
- Swings 30” from structure
- Swing chains of adjacent swing is 24 inches
- Swings hangers at least 20” apart
- Swing seats not metal or wood
- Swing frame designed to discourage climbing and has no designated play surfaces (2”x2”)
- Fully enclosed swing seat (bucket seat) to surfacing = 24”
- Pivot Points of bucket seats should be more than 47 inches but no more than 95 inches above the protective surfacing



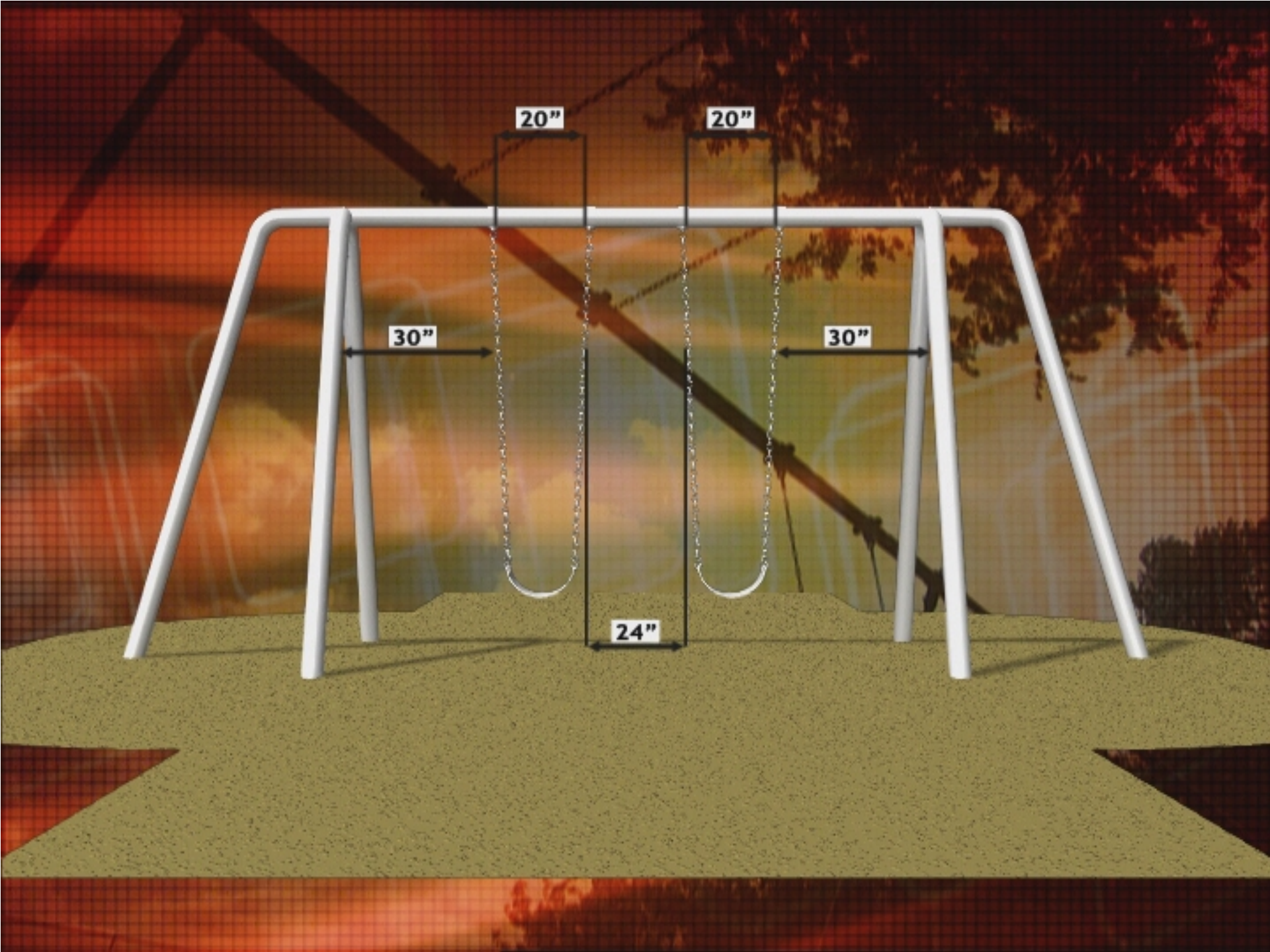

20"

20"

30"

30"

24"

# Swings

- “S” & “C” hook properly closed = .04”
- No greater than the thickness of a dime or credit card
- “S” hooks lower loop should not extend beyond boundary of upper loop.
- “S” hook upper loop or lower loop should not overlap body





PASS



Gap not  
greater  
.04in.  
(1.0mm)



FAIL

FAIL



FAIL



# Tire Swings or Rotating Swings

- Location away from other play structures
- Cannot be attached to composite structure
- Swing frame designed to discourage climbing
- Swing frame to have no designated play surface
- No more than one swing per bay
- Swing seats to not weigh more than 35 lbs.





# Swing Set



# Slides



- Height/length ratio must not exceed 30 degrees.
- Straight slides have a minimum of 4" sides.
- Guardrail and protective barriers must surround a slide appropriately for the platform height.
- Slide exit height for all slides less than 48 in. tall is 0-11 inches
- Slide exit height for all slides more than 48 in. tall is 7-15 in.
- Transition area on slides must no <14"
- No spaces or gaps between the platform and start of chute.
- Tube Slide – min. 23" diameter
- Slides must have means to channel user into a seated position (hood, bar, chute)







# Slide Exit Heights

<48"

0"-11"

Off Ground

>48"

7"-15"

Off Ground

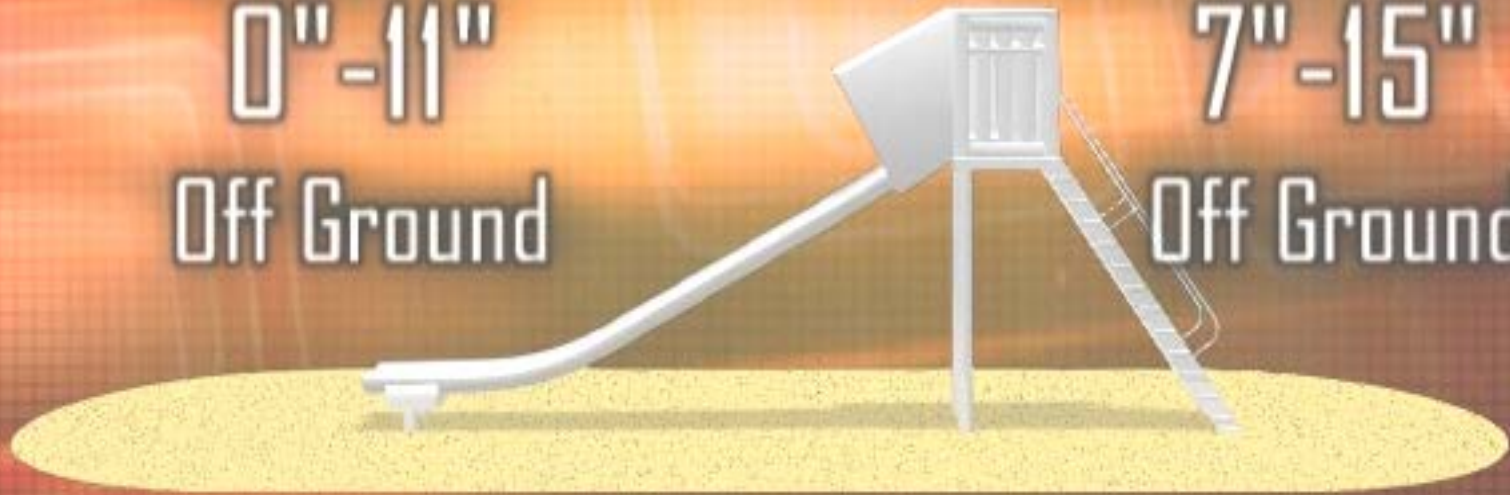

---

# Playground Supervision Guidelines



- Same ratio of adults on the playground as there are in the classroom.
  - Zoning
  - Children should be visible to supervisors.
  - Supervisors should be trained.
  - Emergency plan (notice of insect sting allergies, etc.)
  - Emergency items: radio, phone, gloves, whistle, etc.
-

---

# Playground Safety Management

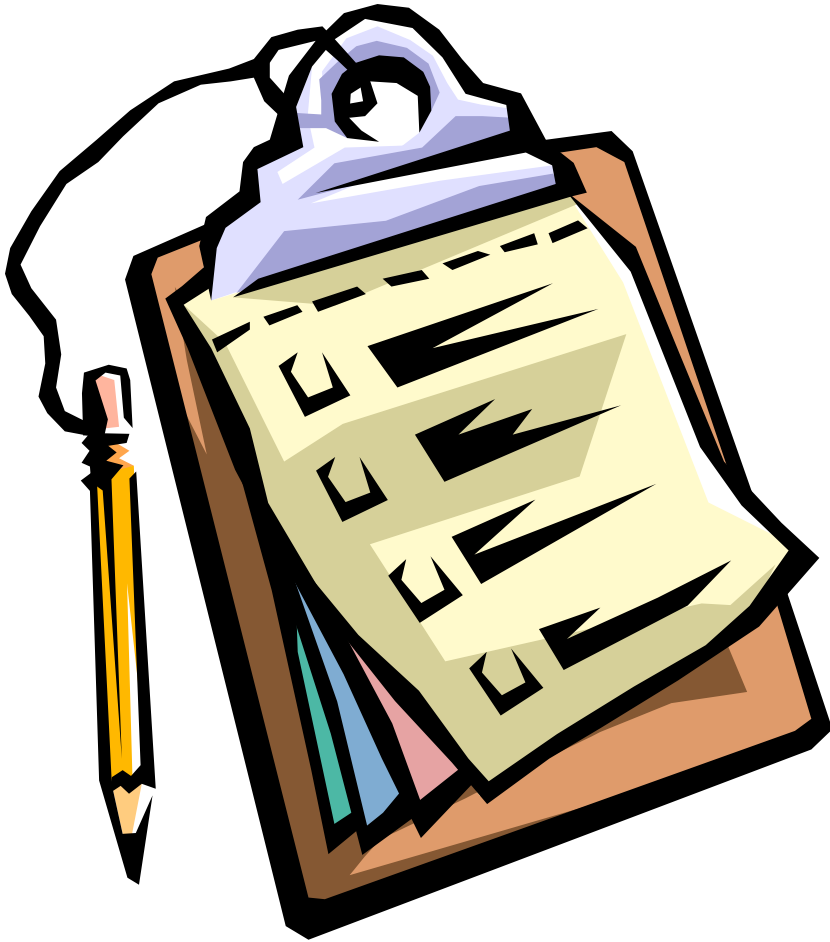

- ❑ Playground Safety Coordination
  - ❑ Audits (top to bottom)
  - ❑ Inspections
  - ❑ Maintenance
  - ❑ Recordkeeping
-



# Inspections

- Manufacturer's maintenance instructions and recommended inspection schedules followed.
- If not available, a maintenance schedule should be developed based on actual or anticipated playground use.
- Routine maintenance does not replace regular inspections.
- All areas should be inspected for excessive wear, deterioration and potential hazards.
- Check moving parts.
- Must be carried out in a systematic manner by personnel familiar with the playground, such as maintenance or playground supervisors.
- CPSC Publication 325, Appendix A and Table 3

---

# Repairs

- Problems found during the inspection should be noted and fixed as soon as possible
  - Follow manufacturer's instructions for repairs and obtain manufacturer's parts
  - Remove loose-ended ropes tied to elevated parts removed immediately (tether ball without the ball)
  - Frequency of inspections depends on the type and age of equipment, the amount of use, and the local climate.
-

# Loose Ropes



---

# Loose-Fill Surfacing

- High use public playgrounds should be checked frequently to ensure surfacing has not displaced significantly, particularly in areas of the playground most subject to displacement (under swings and slide exits).
  - Impact attenuating mats placed in high traffic areas can significantly reduce displacement. Should be installed below or level with surfacing so as not to be a tripping hazard.
  - Pooling water on mulch surfacing. If puddles regularly consider addressing larger drainage issues.
-



---

# Recordkeeping

- Records of ALL maintenance inspections and repairs should be retained, including the manufacturer's maintenance instructions and any checklists used. When any inspection is performed, the person performing it should sign and date the form used. A record of any accident and injury reported to have occurred on the playground should also be retained. This will help identify potential hazards or dangerous design features that should be corrected.
  - Review injuries at each school and during the district safety committee meeting.
-

---

# Example Hazard Priority Rating

- 1. Permanent Disability, loss of life or body part – Condition should be corrected immediately
  - 2. Serious Injury resulting in temporary disability – Condition should be corrected ASAP
  - 3. Minor (Non-Disabling Injury) –Condition should be corrected very soon
  - 4. Potential for Injury Very Minimal – Condition should be corrected if it worsens
  - 5. Existing condition does not present a hazard at this time.
-

---

# Priority 1 Hazard

- Death
  - Brain Damage
  - Permanent Paralysis
  - Loss of Vision
  - Loss of Speech
  - Loss of Limb
  - Organ Destruction
-

---

# Priority 1 Hazard's 3 Factors

- 1. Exposure (easy access by users, heavy use area and condition can become worse)
  - 2. Odds (the probability that users could have an accident as a result of the exposure)
  - 3. Severity (will the accident caused by the hazard typically result in minor or major injuries?)
-



# Inspections/Repairs & Recordkeeping

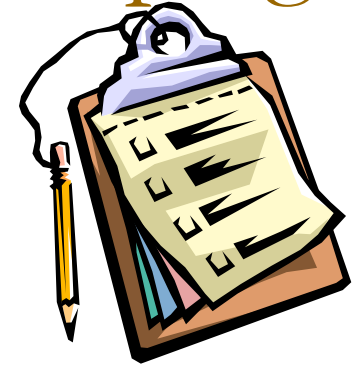

- Performed by trained staff
- Documented with easy-to-use checklists/forms
- Should be based upon Manufacturer's recommendations and entities policies and procedures
- Tailored to equipment and conditions identified in audit
- Based on frequency of use, type and age of equipment and local climate.
- Low Frequency (seasonally, in-depth inspection with focus on preventative maintenance) Document work orders.
- High Frequency (usually done frequently, identifies change with focus on routine and remedial maintenance) Includes surfacing materials.

---

# Factors that Affect Inspection Frequency

- Use Factors
    - Extent of playground use
    - Ages of children using playground
    - Vandalism patterns
  
  - Developmental Factors
    - Types of surfacing materials
    - Materials used to manufacture equipment
    - Age and type of playground equipment
  
  - Environmental Factors
    - Soil/drainage conditions
    - Freezing/thawing
    - Climatic/Atmospheric conditions
-

---

# Track Rides/Log Rolls

- No obstacles along the path of the ride
- No obstacles that would interfere in the take-off or landing areas
- Two track rides next to each other should be at least 4 feet apart
- Handle between 64-78 inches from surfacing
- Rolling parts should be enclosed to prevent crush hazards

## Log Rolls

- Should have handholds to assist with balance
  - Highest point of rolling log should be a maximum of 18 inches above surface
-

# Merry-Go-Round (at least 20 inch diameter)



- Supervision required for pre-school age children
- The underside of the perimeter of the platform should be between 9"-14" above the level of the protective surfacing
- No oscillatory motion (up and down)
- Handgrips diameter range between .95"-1.55"



# Seesaws (Teeter Totter)

- Partial car tires or other shock absorbing material should be embedded in the ground underneath the seat of a fulcrum seesaw.
- Handholds should allow two hands.
- Maximum height is 60” on high end.



# Balance Beams

- **Height**
  - **2-5 ≤ 12”**
  - **5-12 ≤ 16”**
- **No Trip Hazards**



# Guardrails

- ❑ 2-5 yr. old Guardrails
  - Greater than 20"
  - Min. height 29"
  - Max. opening at lower boundary 23"
- ❑ 5-12 yr. Old guardrails
  - Greater than 30"
  - Min. height 38"
  - Max. opening at lower boundary 28"





# Protective Barriers

- ❑ 2-5 yr. Old Barriers
  - If Platform Height Greater than 30"
  - Min. height 29"
  - No opening allows passage of torso probe
- ❑ 5-12 yr. Old Barriers
  - Greater than 48"
  - Min. height 38"
  - No opening allows passage of torso probe





# 2-5 year olds

Guard Rail

Protective Barrier

Top of Rail  
at least  
29" high

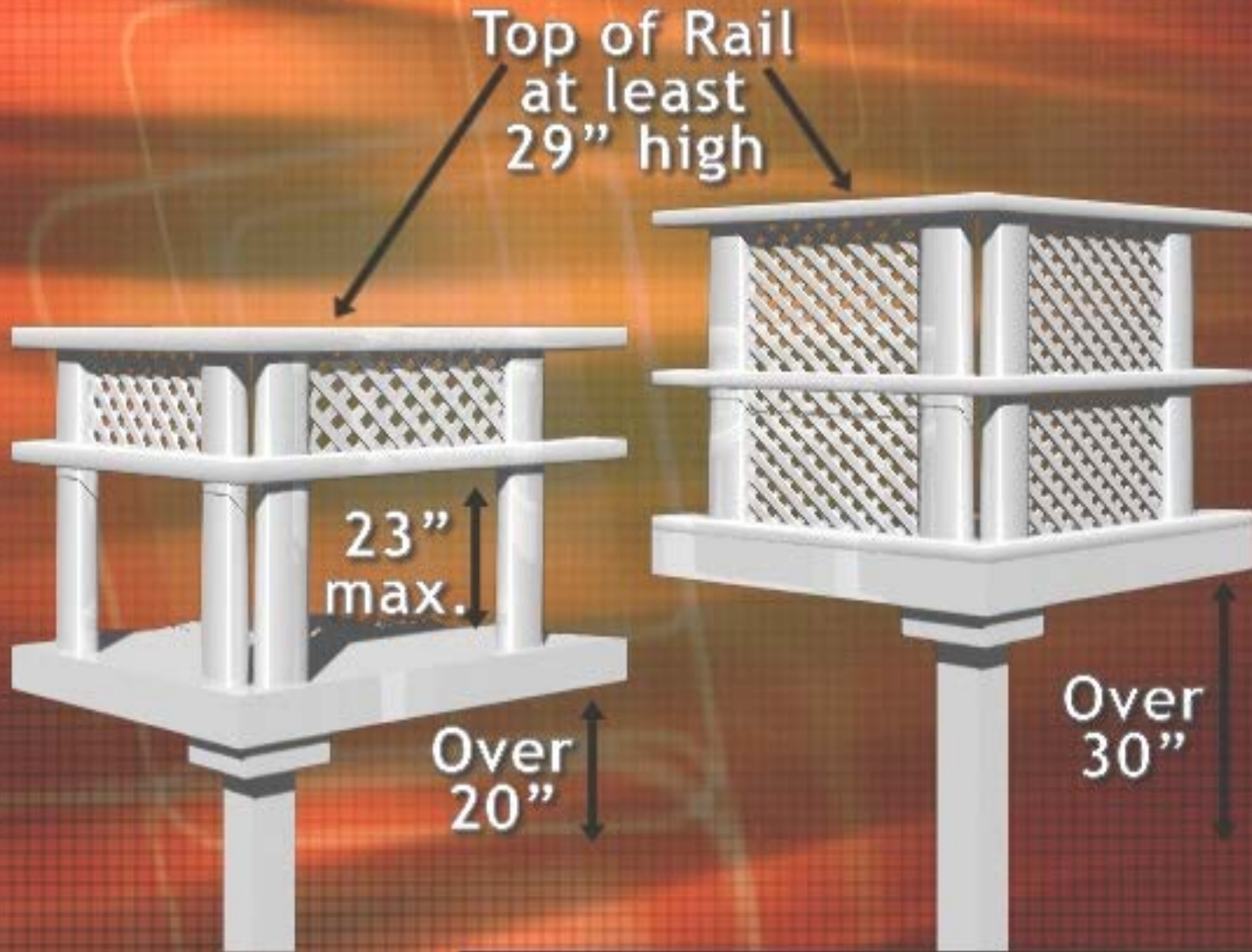

23"  
max.

Over  
20"

Over  
30"



# 5-12 year olds

Guard Rail

Protective Barrier

Top of Rail at least 38" high

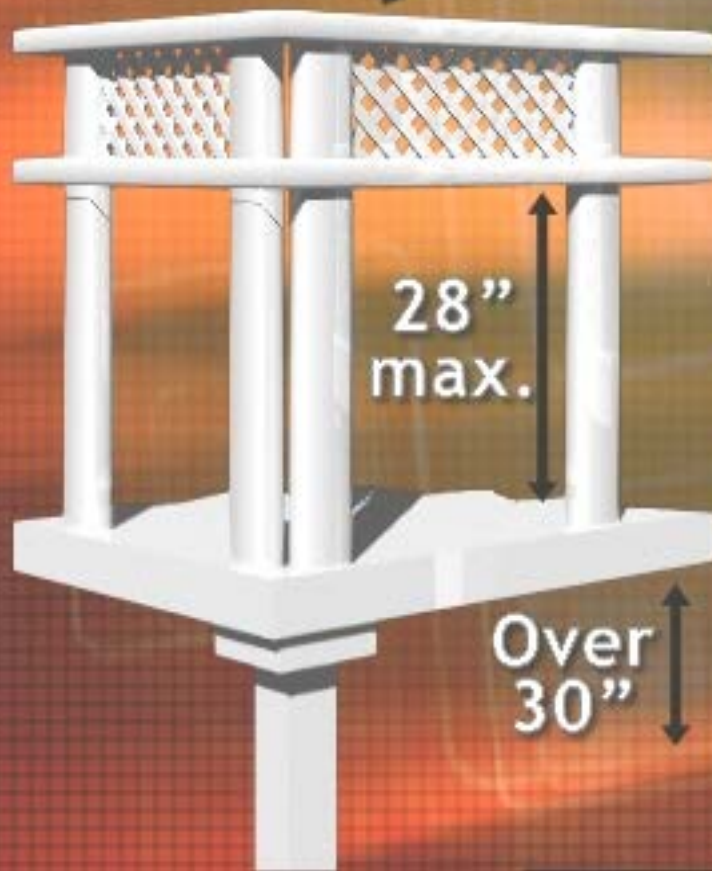

- 
- **A public entity cannot prevent all falls and injuries on playgrounds. It must, however, put controls in place, maintain equipment and document regular inspections in order to reduce the frequency and severity of falls and injuries on public playgrounds.**
-



# Kids Will Be Kids

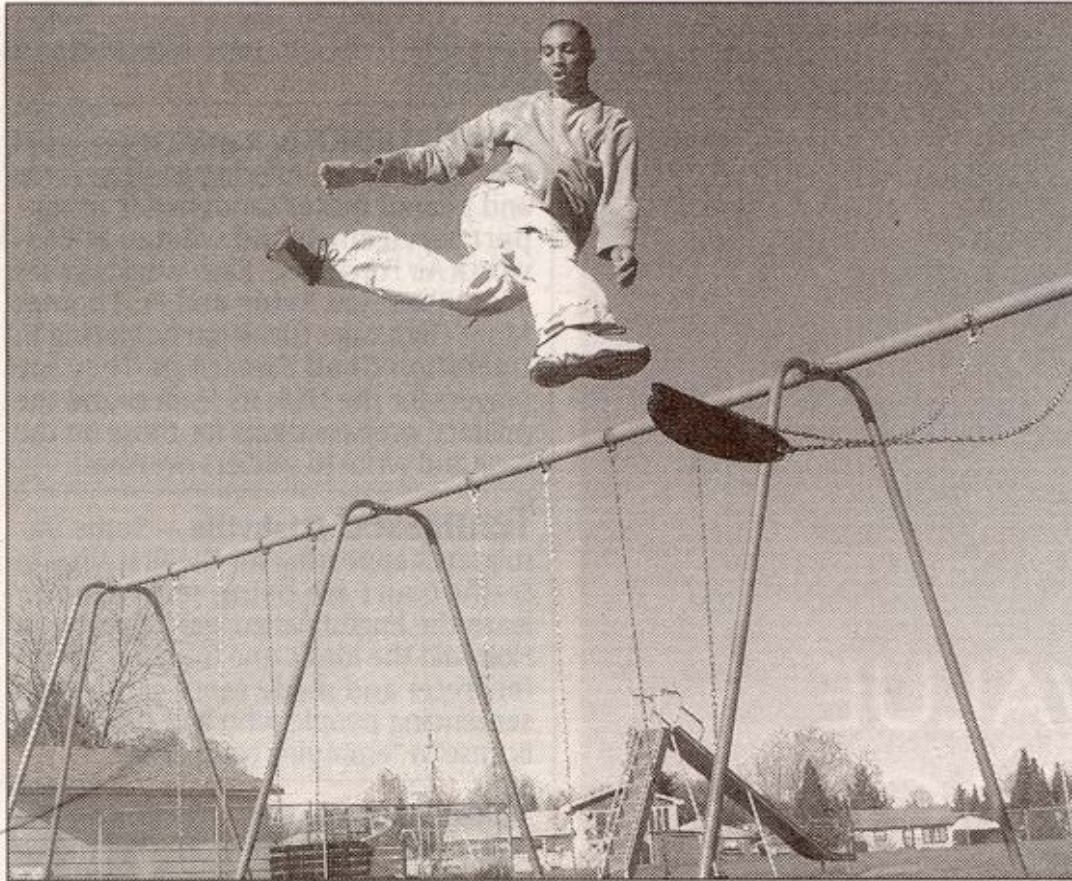

By Mark Sauer, *Mesabi Daily News*, via AP

## Substituting swings for slopes

**Big air:** Competitive snowboarder Garrett Wegener doesn't let a lack of snow keep him from practicing. He rehearses his twists and spins from a playground swing in Mountain Iron, Minn., on Monday afternoon.