

PLD Amplifiers

User Manual

PLD4.2 – 4 Channel, 1600 W Amplifier

PLD4.3 – 4 Channel, 2500 W Amplifier

PLD4.5 – 4 Channel, 5000 W Amplifier

TD-000368-01-A



EXPLANATION OF SYMBOLS

The term "**WARNING!**" indicates instructions regarding personal safety. If the instructions are not followed the result may be bodily injury or death.

The term "**CAUTION!**" indicates instructions regarding possible damage to physical equipment. If these instructions are not followed, it may result in damage to the equipment that may not be covered under the warranty.

The term "**IMPORTANT!**" indicates instructions or information that are vital to the successful completion of the procedure.

The term "**NOTE**" is used to indicate additional useful information.



The intent of the lightning flash with arrowhead symbol in a triangle is to alert the user to the presence of un-insulated "dangerous" voltage within the product's enclosure that may be of sufficient magnitude to constitute a risk of electric shock to humans.



The intent of the exclamation point within an equilateral triangle is to alert the user to the presence of important safety, and operating and maintenance instructions in this manual.



IMPORTANT SAFETY INSTRUCTIONS



WARNING!: TO PREVENT FIRE OR ELECTRIC SHOCK, DO NOT EXPOSE THIS EQUIPMENT TO RAIN OR MOISTURE.

- Keep these instructions.
- Heed all warnings.
- Follow all instructions.
- Do not use this apparatus near water.
- Clean only with a dry cloth.
- Do not block any ventilation opening. Install in accordance with the manufacturer's instructions.
- Do not install near any heat sources such as radiators, heat registers, stoves, or other apparatus (including amplifiers) that produce heat.
- Do not defeat the safety purpose of the polarized or grounding-type plug. A polarized plug has two blades with one wider than the other. A grounding type plug has two blades and a third grounding prong. The wide blade or the third prong are provided for your safety. If the provided plug does not fit into your outlet, consult an electrician for replacement of the obsolete outlet.
- Protect the power cord from being walked on or pinched particularly at plugs, convenience receptacles, and the point where they exit from the apparatus.
- Only use attachments/accessories specified by the manufacturer.
- Unplug this apparatus during lightning storms or when unused for long periods of time.
- Refer all servicing to qualified service personnel. Servicing is required when the apparatus has been damaged in any way, such as power-supply cord or plug is damaged, liquid has been spilled or objects have fallen into the apparatus, the apparatus has been exposed to rain or moisture, does not operate normally, or has been dropped.
- The appliance coupler, or the AC Mains plug, is the AC mains disconnect device and shall remain readily operable after installation.
- Adhere to all applicable, local codes.
- Consult a licensed, professional engineer when any doubt or questions arise regarding a physical equipment installation.

FCC Statement



NOTE: This equipment has been tested and found to comply with the limits for a Class A digital device, pursuant to Part 15 of the FCC Rules. These limits are designed to provide reasonable protection against harmful interference when the equipment is operated in a commercial environment. This equipment generates, uses, and can radiate radio frequency energy and, if not installed and used in accordance with the instruction manual, may cause harmful interference to radio communications. Operation of this equipment in a residential area is likely to cause harmful interference in which case the user will be required to correct the interference at his own expense.

RoHS STATEMENT

The QSC PLD4.2, PLD4.3 and PLD4.5 amplifiers are in compliance with European Directive 2002/95/EC – Restriction of Hazardous Substances (RoHS).

The QSC PLD4.2, PLD4.3 and PLD4.5 amplifiers are in compliance with “China RoHS” directives. The following chart is provided for product use in China and its territories:

		QSC PLD4.2, PLD4.3, and PLD4.5 Amplifiers				
部件名称 (Part Name)	有毒有害物质或元素 (Toxic or hazardous Substances and Elements)					
	铅 (Pb)	汞 (Hg)	镉 (Cd)	六价铬 (Cr(vi))	多溴联苯 (PBB)	多溴二苯醚 (PBDE)
电路板组件 (PCB Assemblies)	X	O	O	O	O	O
机壳装配件 (Chassis Assemblies)	X	O	O	O	O	O

O: 表明这些有毒或有害物质在部件使用的同类材料中的含量是在 SJ/T11363_2006 极限的要求之下。
(O: Indicates that this toxic or hazardous substance contained in all of the homogeneous materials for this part is below the limit requirement in SJ/T11363_2006.)

X: 表明这些有毒或有害物质在部件使用的同类材料中至少有一种含量是在 SJ/T11363_2006 极限的要求之上。
(X: Indicates that this toxic or hazardous substance contained in at least one of the homogeneous materials used for this part is above the limit requirement in SJ/T11363_2006.)

Warranty (USA only; other countries, see your dealer or distributor)

QSC Audio Products 3 Year Limited Warranty

QSC Audio Products, LLC ("QSC") guarantees its products to be free from defective material and/or workmanship and will replace defective parts and repair malfunctioning products under this warranty when the defect occurs under normal installation and use, provided the unit is returned to our factory, one of our authorized service stations or an authorized QSC International Distributor via pre-paid transportation with a copy of proof of purchase (i.e., sales receipt). This warranty provides that the examination of the return product must indicate, in our judgment, a manufacturing defect. This warranty does not extend to any product which has been subjected to misuse, neglect, accident, improper installation, or where the date code has been removed or defaced. QSC shall not be liable for incidental and/or consequential damages. This warranty gives you specific legal rights. This limited warranty is freely transferable during the term of the warranty period. The warranty on QSC products is NOT VALID if the products have been purchased from an unauthorized dealer/online e-tailer, or if the original factory serial number has been removed, defaced, or replaced in any way. Damage to, or loss of any software or data residing on the product is not covered. When providing repair or replacement service, QSC will use reasonable efforts to reinstall the product's original software configuration and subsequent update releases, but will not provide any recovery or transfer of software or data contained on the serviced unit not originally included in the product.

Customers may have additional rights, which vary from state to state or from country to country. In the event that a provision of this limited warranty is void, prohibited or superseded by local laws, the remaining provisions shall remain in effect.

The QSC limited warranty is valid for a period of three (3) years from date of purchase in the United States and many (but not all) other countries.

For QSC warranty information in countries other than the United States, contact your authorized QSC international distributor. A list of QSC International distributors is available at www.qsc.com.

To register your QSC product online, go to www.qsc.com and select "Product Registration". Other questions regarding this warranty can be answered by calling, e-mailing or contacting your authorized QSC distributor.

Phone: 1-800-854-4079 within US and Canada, +1-714-754-6175 international, **Email:** warranty@qscaudio.com, **Website:** www.qsc.com.

Introduction

Built for system integrators, the PLD series amplifiers provide multi-channel amplification with built-in DSP and enough power to drive wide varieties of speaker systems with optimal energy efficiency. The PLD Series consists of three light-weight, 2RU, four-channel amplifiers with on-board DSP and flexible channel combining. These amplifiers not only provide the power and processing to make your system perform better, they offer outstanding efficiency ensuring that energy costs are kept to a minimum over the life of the installation.

PLD amplifiers feature Flexible Amplifier Summing Technology (FAST). Depending on the model, 1600, 2500, or 5000 Watts of total power can be distributed across one to four outputs.

The PLD Series amplifiers use QSC's third-generation class-D power-amplifier design in combination with a custom power stage utilizing a new output device. In addition, PLD amplifiers employ the proven PowerLight power supply in conjunction with Power Factor Correction (PFC) which aligns the current waveform with the AC mains voltage waveform. PFC enables the PLD Series amplifiers to draw current from the wall in a more efficient and controlled manner resulting in very high power from a single standard AC breaker. Additionally, the PLD Series amplifiers offer multi-stage sleep modes saving energy when possible without sacrificing performance. The result is an exceptionally powerful and flexible platform that offers low weight and efficiency.

With four channels of amplification plus signal processing in just 2RUs, the PLD series replaces equipment taking up as much as three times the rack-space.

A single PLD Series amplifier is a capable and sophisticated loudspeaker processor. Integration of processing and amplification means that the DSP knows exactly what the amplifier is doing so dynamics processing can be far more accurate and effective. This approach employs both RMS and Peak Limiters that allow the amplifier and loudspeaker to produce more output without being pushed to distortion or destruction.

The on-board DSP offers four channels of crossover filters, 5-band parametric EQ/Low-shelf/High-shelf, alignment delay and dynamics processing – everything needed to optimize a loudspeaker system. Additionally when using QSC loudspeakers, PLD amplifiers provide Intrinsic Correction™, a combination of filtering, limiting and loudspeaker knowhow that was first developed for QSC's WideLine line-array loudspeakers. Intrinsic Correction compensates for the non-linearity in array and horn design resulting in exceptional performance.

The PLD also includes manufacturers' recommended tunings for the most popular passive loudspeakers. A system setup wizard helps you select the right preset, or select one of the 20 configuration templates and create tunings that you can save in the user preset library.

With a dedicated front panel user interface, complete with LED meters and indicators, a 400 x 240 TFT color display, a rotary encoder and navigation buttons, the PLD amplifiers provide an intuitive means to control the system.

Unpacking

There are no special unpacking instructions. You may want to keep the shipping material for the unlikely event that the amplifier should need returning for service.

Package Contents

1. Quick-Start Guide TD-000351-00
2. Warning Information Sheet TD-000420-00
3. PLD Amplifier
4. IEC AC Power Cord
5. USB Cable

Features

Amplifier Front Panel

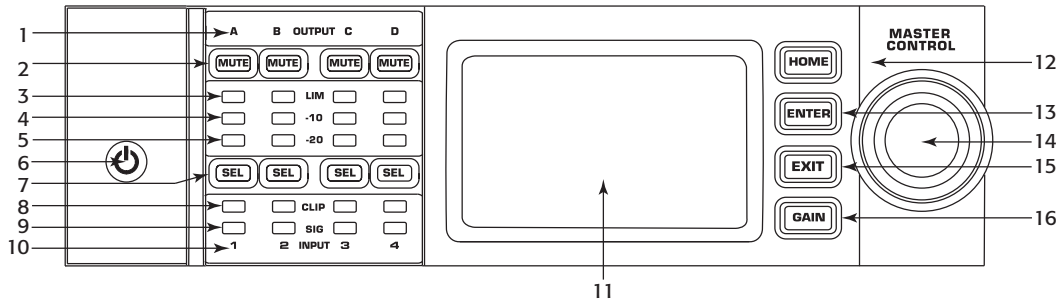

– Figure 1 –

- | | |
|---|---|
| 1. Output channels are labeled A, B, C, and D | 9. Input Channel Signal-Present LEDs (Blue) |
| 2. Output Channel Mute Buttons and LEDs (Red) | 10. Input channels are labeled 1, 2, 3, and 4 |
| 3. Output Channel Limiter LEDs (Red) | 11. LCD Graphic Display |
| 4. Output Channel -10 dB Below Limiter Activation LEDs (Blue) | 12. HOME Button |
| 5. Output Channel -20 dB Below Clip LEDs (Blue) | 13. ENTER Button |
| 6. Soft Power Button (Blue/Red) | 14. MASTER CONTROL Knob |
| 7. Channel Select Buttons and LEDs (Amber for Input, Blue for Output) | 15. EXIT Button |
| 8. Input Channel Clip LEDs (Red) | 16. GAIN Button |

Amplifier Rear Panel



NOTE: The PLD4.3, and PLD4.5 models have a different rear panel configuration than the PLD4.2 rear panel. The difference is the position of the fan and the connectors.

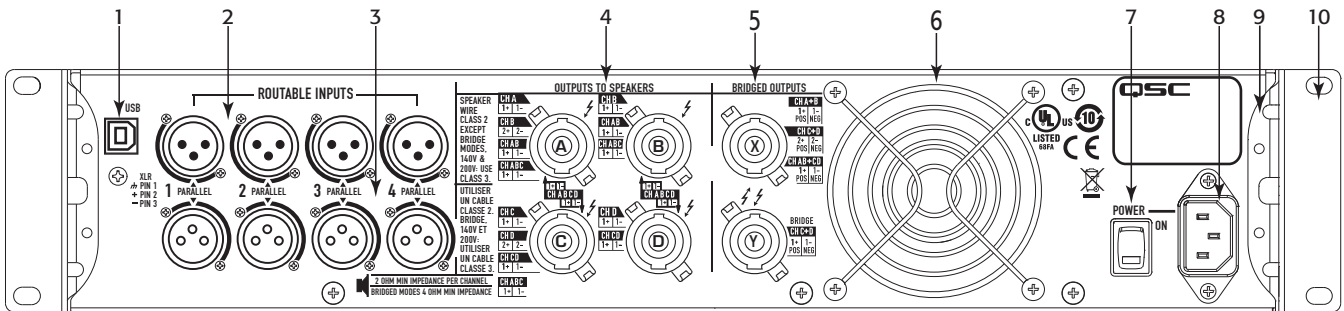

– Figure 2 –

- | | |
|---|---|
| 1. USB Type B, 4-Pin | 6. Cooling Fan |
| 2. Four XLR-F Female Line Input Connectors | 7. Power Switch |
| 3. Four XLR-M Male Line Output Connectors | 8. Locking IEC Power Connection (100 – 240 VAC, 50 – 60 Hz) |
| 4. Four NL4 Output Connectors (Individual and Parallel) | 9. Rear Rack-mount Brackets |
| 5. Two NL4 Output Connectors (Bridged Outputs) | 10. Front Rack-mount Brackets |

Amplifier Control

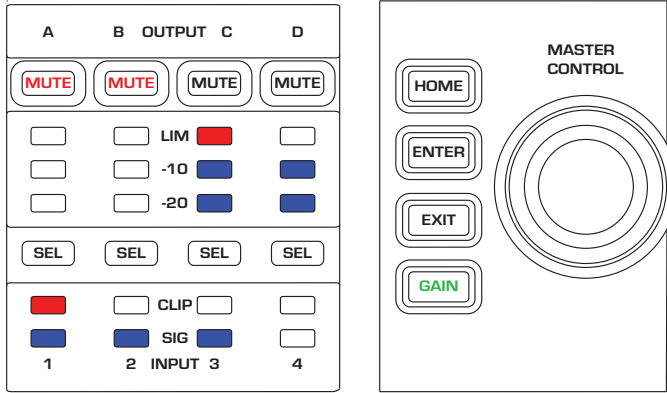

– Figure 3 –

Off Mode



- Rear power switch is off, the amplifier is not operable. The power switch is the AC Mains disconnect.
- The power button is not illuminated.
- Turn the power switch to on. The amplifier enters the mode it was in when power was removed. The power button is illuminated based on the mode.

Run Mode



- From Standby or Mute All modes, press and release the power button on the front panel.
- The power button is illuminated blue.
- The amplifier is fully operable; audio can pass.

Standby Mode



- From Mute All or Run modes, press and hold the power button on the front panel for two to three seconds.
- The power button illuminates solid red.
- The front panel LCD is off.
- The amplifier is not operable; audio will not pass.

Mute All Mode



- From the Run Mode, quickly press and release the power button.
- The power button flashes red.
- The outputs are muted and amplifiers are off.
- The front panel and DSP functionality are fully operable. Any changes you make are saved and take effect in the Run Mode.

Master Control Knob



- Scrolls up/down and right/left to select menu items and parameters
- Adjusts parameters

ENTER Button



- Navigates into the menu structure
- Enters the edit mode for adjusting parameters
- Confirms the changes you make and exits edit mode.

EXIT Button



- Navigates out of the menu structure and parameter selection.
- In the edit mode, pressing EXIT reverts the value back to its prior state, and exits the edit mode.

HOME Button



- If you are on the Home screen, pressing HOME displays the alternate Home screen. Pressing HOME again returns you to the primary Home screen.
- If you are on a navigation screen, pressing HOME takes you to the home screen.
- If you are on an edit screen, pressing HOME will confirm any value being edited and take you to the Home screen.

GAIN Button



- Pressing the GAIN button from any screen takes you to the output gain screen for the most recently accessed output channel.
- Pressing GAIN again confirms the gain change and returns to the screen you were on when you pressed GAIN.
- The Gain button illuminates green when selected.

SEL Buttons



- Use these buttons to navigate between input channels or output channels. For example, if you are adjusting output gain on channel A, pressing the channel B SEL button takes you to the gain adjustment for channel B.
- The SEL buttons are active only when the LCD screen is on an input or output parameter adjustment screen.
- The SEL buttons illuminate blue for output channels, and amber for input channels.

LIM LEDs



- Illuminates red when the Limiter is engaged.

-10 and -20 LEDs



- Indicates the output level of the channel.

CLIP LEDs



- Illuminates red when the input signal is being clipped.

SIG LEDs



- Illuminates blue when a signal is present.

PLD Amplifier Signal Flow

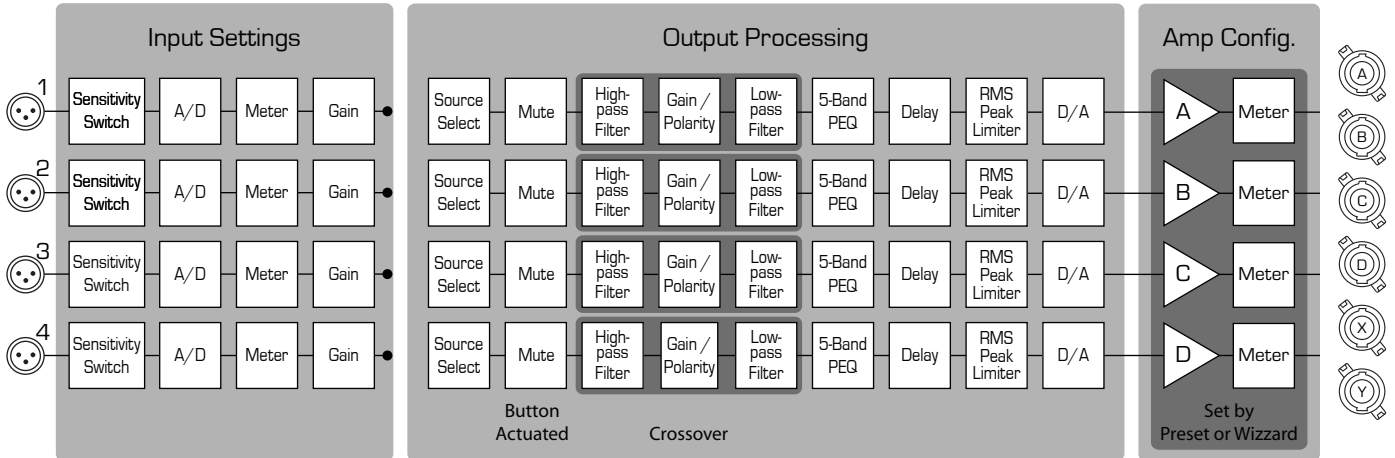

– Figure 4 –

Screen Types

Informational

Informational screens, like the HOME screen, are designed to provide you with a good amount of useful information at a glance.

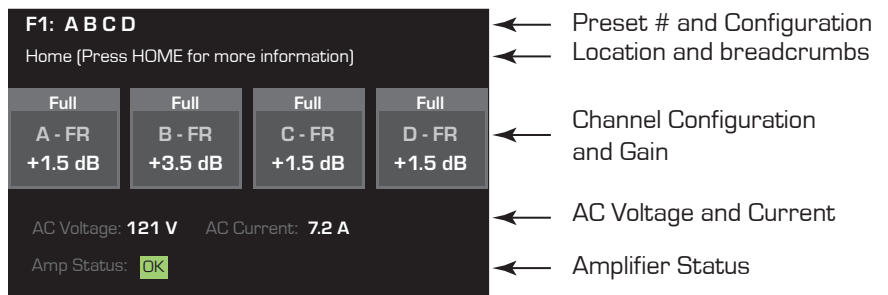

– Figure 5 –

Navigational

Navigational screens provide the means to move around and select menu items. Use the Master Control knob, ENTER and EXIT buttons for navigation. This is an example of one type of navigational screen, there are others.

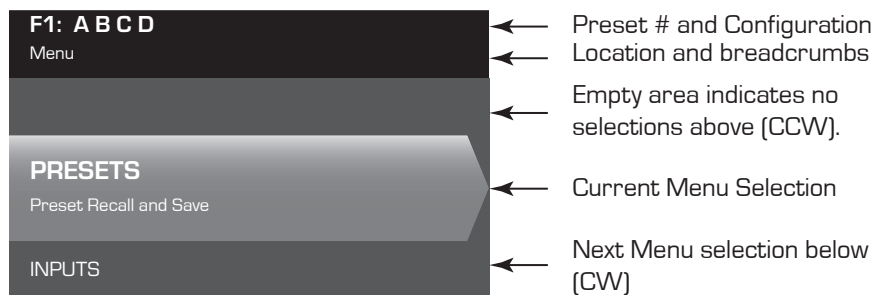

– Figure 6 –

Parameter Editing

Parameter editing screens allow you to select, edit, and confirm changes for various system parameters. Use the ENTER button to edit and confirm changes to parameters. Use the Master Control knob to select parameter, and make adjustments. Use the EXIT button to exit the edit mode without saving changes.

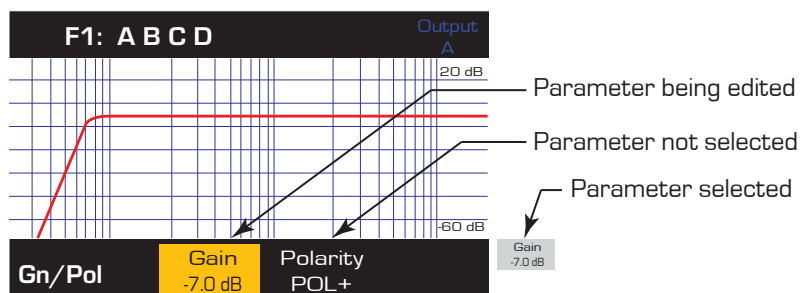

– Figure 7 –

Menu Tree

Presets

- Preset Recall
- Preset Save
- Preset Wizard

Inputs

- Input Sensitivity
- Input Gain

Outputs

- Source Select
- Processing
 - Crossover
 - PEQ
 - Delay
 - Limiter
 - Array Correction *
- Load Speaker
- Save Speaker

Utilities

- Status
- Amp ID
- Display
- Lockout
- Password

*For GSC Line Arrays only

About Presets

The PLD amplifiers are preset driven. In order to get the most out of the amplifiers, an understanding of how presets work is essential. A Preset, in the context of the PLD amplifiers, is a combination of amplifier configuration (inputs and outputs), DSP and loudspeaker assignments. When a preset is recalled it can change the output routing and wiring and/or any of the DSP settings.

The PLD amplifiers come with 20 unchangeable factory presets, and 50 user-defined presets. The factory presets are designed to be starting points for creating the presets you need for your particular installation. Factory presets F1: thru F9: have no DSP or loudspeaker assignments, only output configurations. Factory presets F10: thru F20: include basic settings along with the output configurations.

Creating User-defined Presets

A preset can be created in two ways, the first is to modify an existing preset, then save this as a new preset. The second is to use the Preset Wizard to create a Preset from scratch.

Save As a New Preset

After selecting a starting preset, navigate through the Input and Output menus to select and modify the parameters needed for your system. After modifying the parameters for each channel, return to the Preset menu and save your work. If you started with a user-defined preset, you can update the preset you started with using the SAVE function or, you can use the SAVE AS function.

Preset Wizard

The Preset Wizard simplifies the preset creation process, and allows you to create a preset from the ground up. The Preset Wizard provides a mechanism for you to select the desired power and load. Based on these selections, the best amplifier configuration is selected and you are then allowed to select and assign loudspeakers to each output.



NOTE: By default, all 50 of the user-defined presets are configured the same as factory preset F1. Either method described above "overwrites" some existing preset. The main difference is the SAVE function overwrites only the preset number you started with, and the SAVE AS function allows you to save to a different user preset number and change the name.

Installation

The following steps are written in the recommended installation order.

Mount the PLD Amplifier

The PLD Series amplifiers are designed to be mounted in a standard rack-mount unit. The amplifiers are 2RU high, the PLD4.3 and 4.5 are 381 mm (15 in) deep, the PLD4.2 is 229 mm (9 in) deep.

Depending on the depth of your rack, the Rear Rack Ear Support kit (FG-000031-00) may be required for rack mounting. Refer to <http://qsc.com/products/> under Accessories for details.

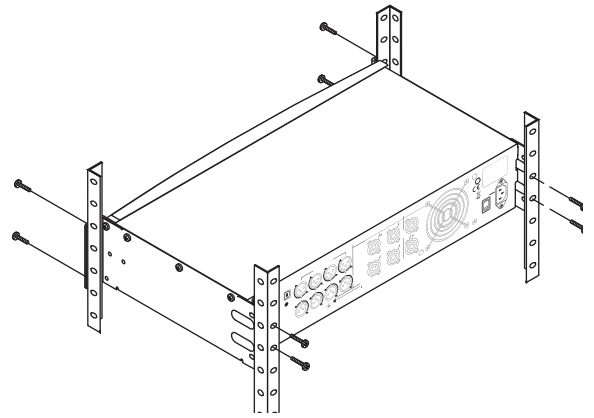

– Figure 8 –



CAUTION! Be sure that nothing is blocking the front or rear ventilation openings, and that each side has a minimum of 2 cm clearance.

1. Use the proper fastening hardware (not included) to secure the amplifier in the rack. The PLD4.3 and PLD4.5 have four front and four rear mounting tabs. The PLD4.2 has four front mounting tabs.

AC Mains



WARNING! When the AC Power is on, there is a potential of having dangerous voltage at the output terminals on the rear of the amplifier. Use caution not to touch these contacts. Turn off the AC Mains disconnect switch prior to making any connections.

The PLD amplifiers have a Universal power supply 100 – 240 VAC, 50 – 60 Hz, with an IEC locking connector.

1. Connect the IEC AC power cord to the rear AC inlet and the AC source.

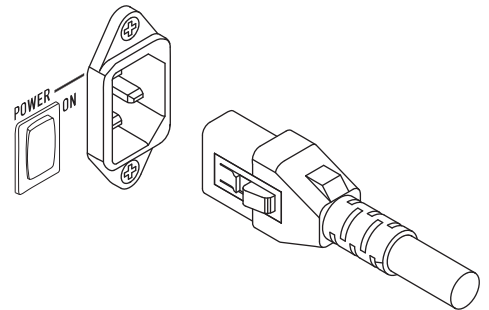

– Figure 9 –

AC Power



NOTE: If the amplifier has no audio for fifteen minutes, the amplifier stops switching. The amplifier returns to the Run mode the instant audio is present.”

When you remove power from the amplifier, then re-apply the power, the amplifier returns to its last state.

Inputs

Connect the Audio Inputs

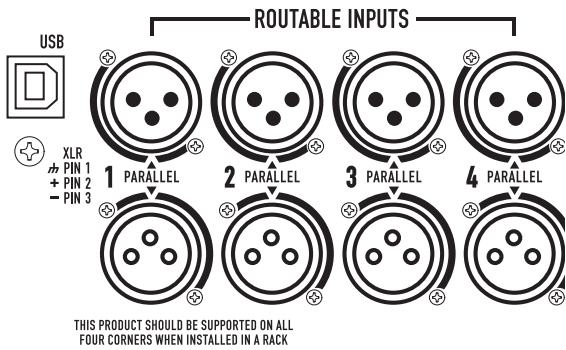

– Figure 10 –

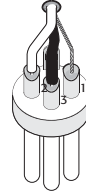
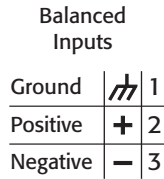

– Figure 11 –

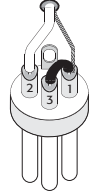
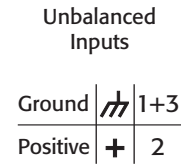

– Figure 12 –

There are four female XLR connectors labeled 1 through 4 that provide the audio inputs to the PLD amplifiers. A single input can be routed to one or a combination of outputs. You can use from one to four of the inputs. The inputs are 10 kΩ balanced or unbalanced, with a selectable sensitivity of either +4 or +14 dBu. There are four male XLR connectors in parallel with the four female connectors. The male XLRs are for daisy chaining to the inputs of other amplifiers.

1. Make sure your audio source devices are powered off.
2. Connect the input source XLRs to the four female XLRs. (Figure 10)



NOTE: The PLD Series has the capability of routing the inputs to different outputs. Be sure that the connections you make here match the configuration of the amplifier.

USB (Optional)

The USB cable (supplied) connects to a Mac or PC for use with the Amplifier Navigator software. You can update the amplifier firmware, save and deploy configuration files, and more. Refer to the Amplifier Navigator online help for details.

Outputs

The PLD amplifiers have four configurable outputs. You can set the power, combine outputs (bridged and parallel), and adjust the DSP for each output. When the output configuration of the amplifier changes, the output connections, controlled by relays, change accordingly. Use the diagrams shown in Figure 14 thru Figure 22 as a reference for wiring the loudspeakers.

Select the Output Configuration

The first step is to select a Preset based on the loudspeakers being connected to the amplifier. You can use a factory preset, and then adjust the parameters as needed, then save the configuration as a user-defined preset. In addition, you can use the "Power Distribution Charts" on page 15 to create presets from the ground up. When the configuration is changed, all four channels are automatically muted.

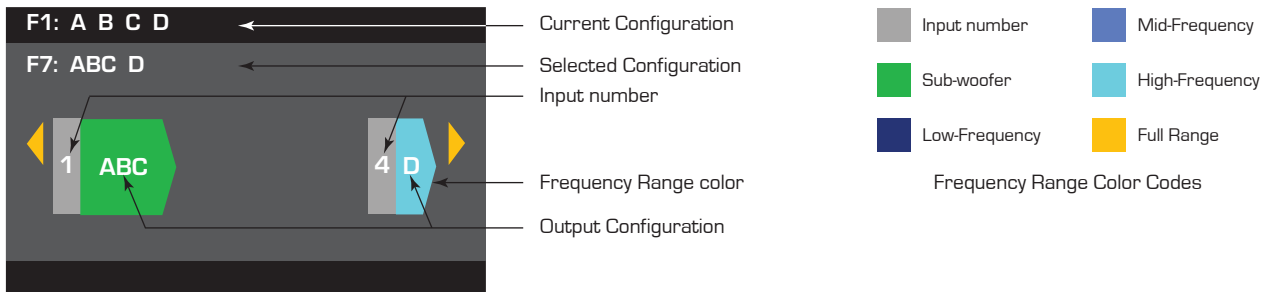

– Figure 13 –



WARNING! When the AC Power is on, there is a potential of having dangerous voltage at the output terminals on the rear of the amplifier. Use caution not to touch these contacts. Turn off the AC Mains disconnect switch prior to making any connections.



IMPORTANT! QSC recommends that you connect jumpers where the terminals are the same points electrically. Refer to Figure 14 thru Figure 22.

1. Turn the AC Mains power switch to on. The amplifier starts in the Run mode, or the last mode it was in before power was turned off.
2. Press and release the front-panel power button. The button flashes red, the amplifier is in Mute All mode.
3. Select the configuration appropriate for your loudspeakers, using either Preset Recall, or the Preset Wizard.

The following is a list of configurations for 1-, 2-, 3-, and 4-channel outputs. This is not an exhaustive list, but is intended to give you an idea of what is available and how the outputs would be wired.

One-Channel Configurations

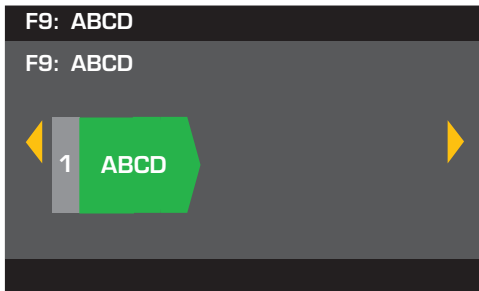

ABCD Parallel

■ = Subwoofer

The following are electrically the same point
A, B, C, and D, (1+)
A, B, C, and D, (1-)

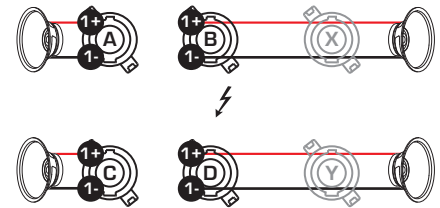

You can use any, or all of the connectors A, B, C, and/or D.

– Figure 14 –

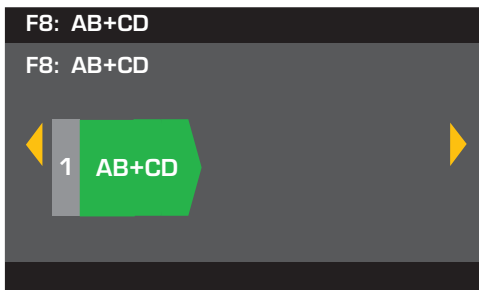

AB in Parallel
Bridged with
CD in Parallel

■ = Subwoofer

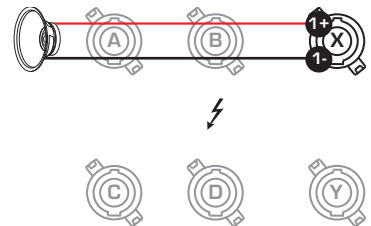

– Figure 15 –

Two-Channel Configurations

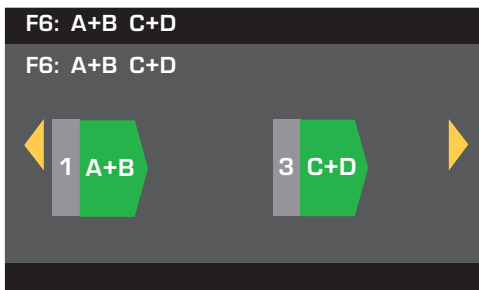

A+B Bridged
C+D Bridged

■ = Subwoofer

The following are electrically the same point
X (2+) and Y (1+)
X (2-) and Y (1-)

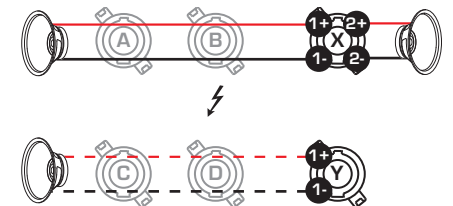

Optional - - - -

– Figure 16 –

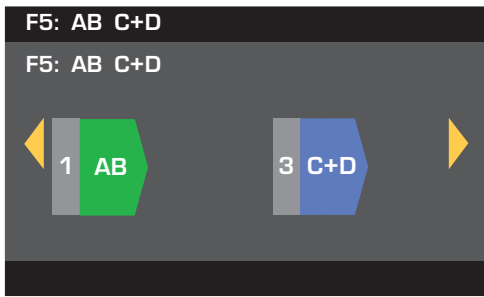

AB Parallel
C+D Bridged

■ = Subwoofer
■ = Mid Range

The following are electrically the same point
A (1+) and B (1+)
A (1-) and B (1-)
X (2+) and Y (1+)
X (2-) and Y (1-)

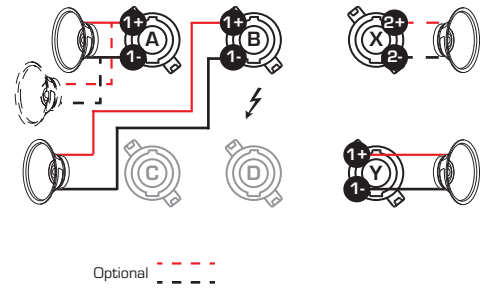

– Figure 17 –

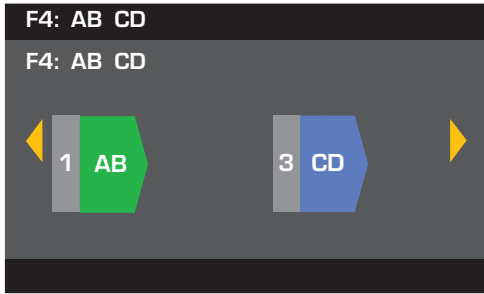

AB Parallel
CD Parallel

■ = Subwoofer
■ = Mid Range

The following are electrically the same point
A (1+) and B (1+)
A (1-) and B (1-)

C (1+) and D (1+)
C (1-) and D (1-)

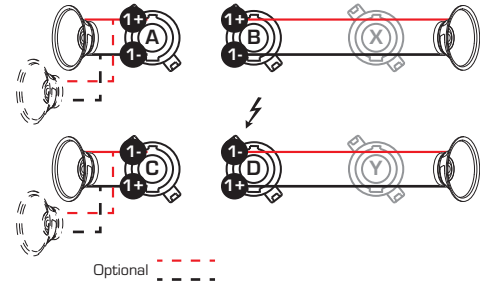

– Figure 18 –

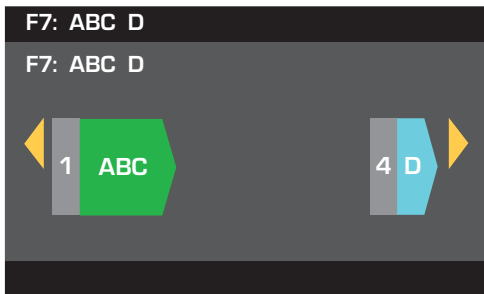

ABC Parallel
D Single

■ = Subwoofer
■ = High Range

The following are electrically the same point
A (1+), B (1+), and C (1+)
A (1-), B (1-), and C (1-)

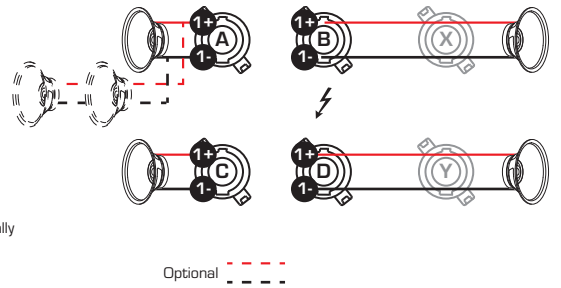

– Figure 19 –

Three-Channel Configurations

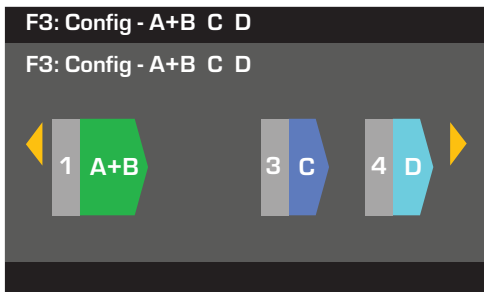

A+B Bridged
C Single
D Single

■ = Subwoofer
■ = Mid Range
■ = High Range

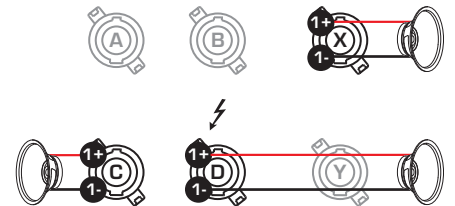

– Figure 20 –

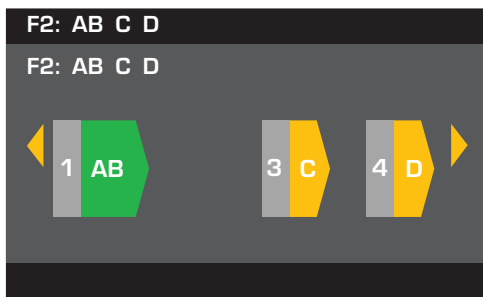

AB Parallel
C Single
D Single

■ = Subwoofer
■ = Full Range

The following are electrically the same point
A (1+) and B (1+)
A (1-) and B (1-)

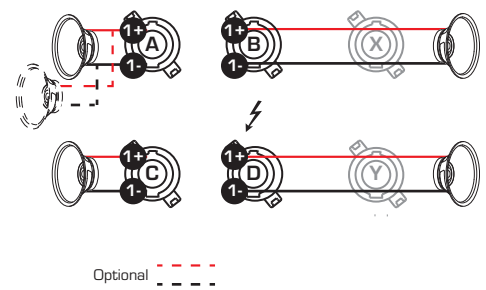

– Figure 21 –

Four-Channel Configuration

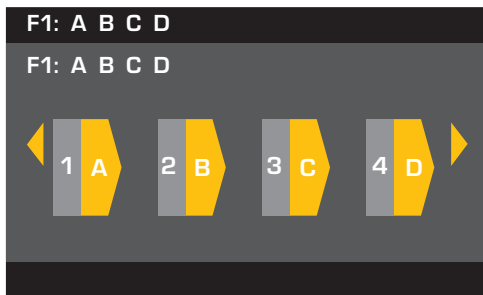

A Single
B Single
C Single
D Single

■ = Full Range

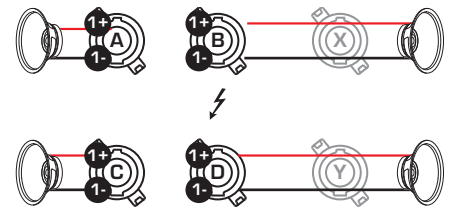

– Figure 22 –

Connect the Loudspeakers



WARNING! When the AC Power is on, there is a potential of having dangerous voltage at the output terminals on the rear of the amplifier. Use caution not to touch these contacts. Turn off the AC Mains disconnect switch prior to making any connections.

1. Turn the AC Mains power switch on the back of the amplifier to OFF.
2. Connect the loudspeaker wiring to male NL4 connectors (Figure 23) as needed for your amplifier's configuration. Refer to Figure 14 thru Figure 22 for wiring diagrams. When combining channels, QSC recommends that you connect jumpers between output terminals that are the same points electrically. Refer to Figure 14 for details.
3. Connect the male NL4 connectors to the female NL4 connectors, on the rear of the amplifier, according to your amplifier's configuration.

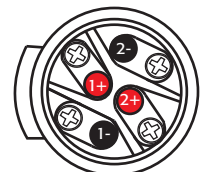

Male NL4 Wiring

– Figure 23 –

The following table shows you which pins on which NL4 you can use for each mode. Where there is more than one connector for a given mode, the PLD allows you to use one, all or some of the available connectors. For example, in ABCD Parallel mode, you can use pins 1+ and 1- of NL4 (A, B, C, and D), (A, or B, or C, or D), or (A and B), and so on; the pins are all in parallel and electrically the same point. It is recommended that where the pins are electrically the same, you use all available pins whether by jumpers between pins, or direct wiring to each loudspeaker

NL4	Mode			
	Separate	AB Parallel	ABC Parallel	ABCD Parallel
A	Ch A 1+ / 1- Ch B 2+ / 2- ¹	1+ / 1-	1+ / 1-	1+ / 1-
B	1+ / 1-	1+ / 1-	1+ / 1-	1+ / 1-
CD Parallel				
C	Ch C 1+ / 1- Ch D 2+ / 2- ¹	1+ / 1-	1+ / 1-	1+ / 1-
D	1+ / 1-	1+ / 1-	1+ / 1-	1+ / 1-

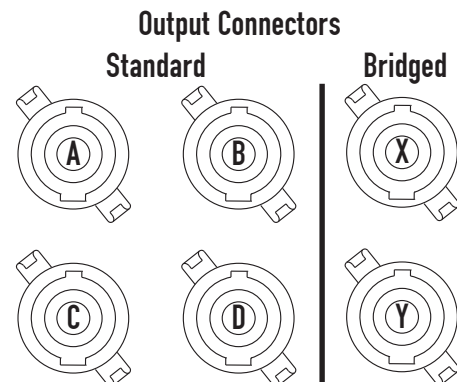

– Figure 24 –

	A+B Bridged	C+D Bridged	AB+CD Bridged
X	1+ / 1-	2+ / 2- ¹	1+ / 1-
Y		1+ / 1-	

– Table 1 –

¹ For Bi-Amp operation.

AC Power On

After connecting the outputs to the loudspeakers, you may turn the amplifier on.

1. Make sure the output gain settings for all audio-source devices (CD Players, Mixers, Instruments, etc.) at the lowest output (max attenuation).
2. Turn on all audio sources.
3. Turn the AC Mains power switch on the back of the amplifier to ON. The amplifier starts in the state it was in when power was removed.
4. You can now bring up the outputs of your audio sources.

Power Distribution Charts

The following charts show the maximum power output for each channel in each configuration, and under different loads.

PLD 4.3 – Total Power: 2500W												
Configuration	8Ω Load				4Ω Load				2Ω Load			
	A	B	C	D	A	B	C	D	A	B	C	D
4 CH (A B C D)	625	625	625	625	650	650	650	650	600	600	600	600
3 CH (AB C D)	1000		625	625	1200		650	650	1200		600	600
3 CH (A+B C D)	1250		625	625	1150		650	650	625		600	600
2 CH (AB CD)	1000		1000		1200		1200		1200		1200	
2 CH (AB C+D)	1000		1250		1200		1150		1200		625	
2 CH (A+B C+D)	1250		1250		1150		1150		625		625	
2 CH Alt (ABC D)	1100			625	2000			650	2500			600
1 CH (ABCD)	1100				2100				2500			
1 CH (AB+CD)	2500				2370				2230			

– Table 2 –

PLD 4.5 – Total Power: 5000W												
Configuration	8Ω Load				4Ω Load				2Ω Load			
	A	B	C	D	A	B	C	D	A	B	C	D
4 CH (A B C D)	1150	1150	1150	1150	1250	1250	1250	1250	625	625	625	625
3 CH (AB C D)	1200		1150	1150	2250		1250	1250	2100		625	625
3 CH (A+B C D)	2250		1150	1150	1150		1250	1250	625		625	625
2 CH (AB CD)	1200		1200		2250		2250		2100		2100	
2 CH (AB C+D)	1200		2250		2250		1150		2100		625	
2 CH (A+B C+D)	2250		2250		1150		1150		625		625	
2 CH Alt (ABC D)	1150			1150	2400			1250	4100			625
1 CH (ABCD)	1150				2300				4200			
1 CH (AB+CD)	4200				4250				2250			

– Table 3 –

Preset Wizard



NOTE: The power levels shown in this procedure are taken from the PLD4.3 unless indicated otherwise. PLD4.2 will show less power and PLD4.5 will show greater power.

HOME > PRESETS > PRESET WIZARD > ENTER

Step 1 – Adjust Impedance and Power

OUTPUTS
SPEAKERS
SAVE

	A	B	C	D
Output:	A	B	C	D
Imped:	8.0	--	--	--
Power:	625	--	--	--
Remaining Power Available: 1875 W				
Enter Load Profile (Impedance and Power)				

Adjust Impedance based on the total loudspeaker load connected to the channel.

← Default = 8 Ω

← Default = min. for amp

Impedance and Power are dynamically linked for adjustments.

Scroll to select (Imped or Power)

To edit, press

Turn to adjust parameter

To confirm, press

Repeat for remaining output channels

Possible Output Mode Combinations using the Preset Wizard

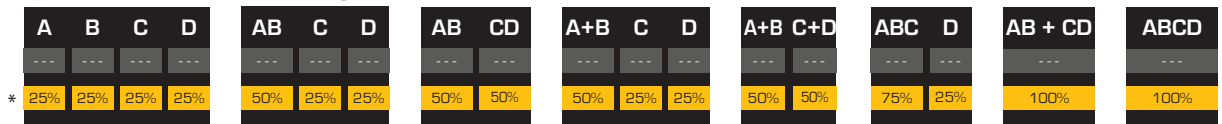

Modes: A B = Separate Channels / A+B = Bridge Mode / AB = Parallel Mode

* Percentages are used to represent the power for different amplifier models.

– Figure 25 –

Step 2 – Select Output Channel for Speaker Assignment

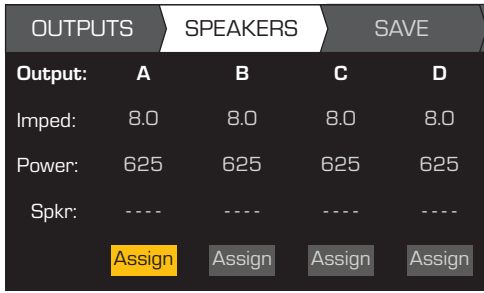

When you are finished setting the Impedance and Power for each output, continue to scroll to access the SPEAKERS tab.

Loudspeaker assignment is optional, you can assign a loudspeaker to one or more channels, or none at all.

Scroll to select Output channel

To Assign a loudspeaker, press Continue to Step 3.

Step 3 – Select Speaker Type for Channel

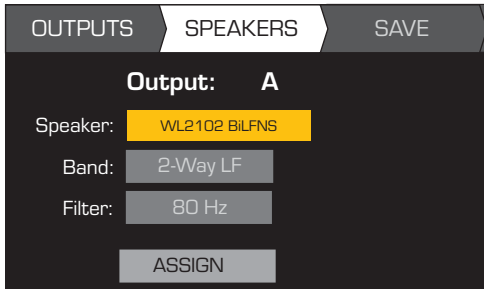

Band and Filter selections are based on the Speaker you select. You must select a loudspeaker before selecting Band and Filter.

To edit Speaker, press

Scroll to select a Speaker model

To confirm, press

Scroll to select (Band, Filter)

To edit, press

Turn to adjust parameter

To confirm, press

Scroll to select ASSIGN

To assign the speaker to the output channel, press

Step 4 – Select User Preset Number

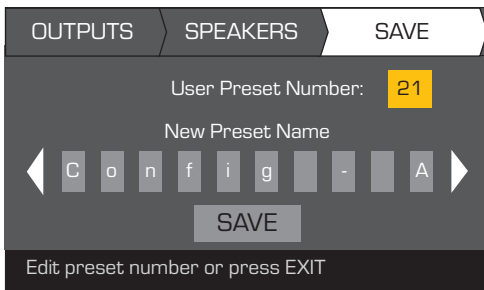

When you have finished selecting loudspeakers, continue to scroll to access the SAVE tab.

Scroll to the Save screen

To edit User Preset number, press

Turn to adjust parameter

To confirm, press

Step 5 – Assign New User Preset Name

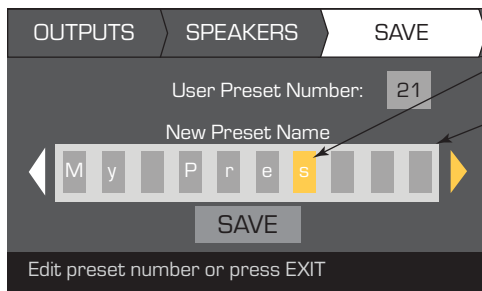

Indicates editing

Indicates "New Preset Name" selection

Up to 21 characters
A-Z / a-z / 0-9 /
_ / - / space

Scroll to New Preset Name press

Scroll to desired letter position press

Turn to select desired character press

When finished, scroll to SAVE press

Create New Preset from an Existing Preset

To create a preset from an existing preset, recall the preset with the desired output configuration, modify the Input parameters, Output parameters, then save the preset. In addition, you can save the preset as you are going thru the creation process.

Recall a Preset

A Preset includes the output configuration, input parameters, and loudspeaker profiles (DSP, load, and assignments). There are 20 factory presets that can be recalled, but not overwritten.

- Factory presets F1: thru F9: contain output configurations only.
- Factory presets F10: thru F20: contain the output configurations and basic DSP for the configurations.
- There are 50 user presets that can be recalled and overwritten.

HOME > PRESETS > PRESET RECALL > ENTER

Step 1 – Select Preset

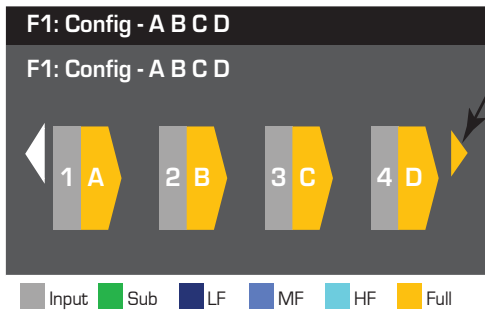

Indicates more Presets

Scroll to desired Preset
20 Factory, 50 User-defined

Step 2 – Confirm Selection

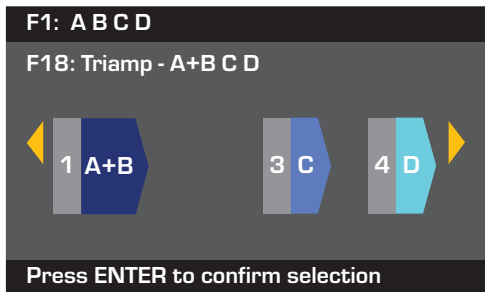

To select the Preset configuration, press

To confirm the selection, press

The message at the bottom changes to: "Recalling Preset now..."
You may hear relays clicking

Set up the Inputs



NOTE: Changes made to input levels are in real time.

HOME > INPUTS > INPUT SENS > ENTER

Step 1 – Select Input Sensitivity

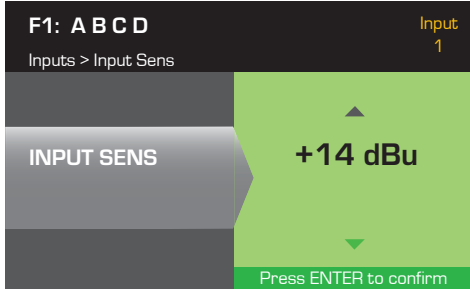

Scroll to select (+14 or +4 dBu)
(The background turns to green.)

To confirm selection, press

To move to the next input, press

Repeat procedure for remaining input channels.

HOME > INPUTS > INPUT GAIN > ENTER

Step 2 – Set Input Gain

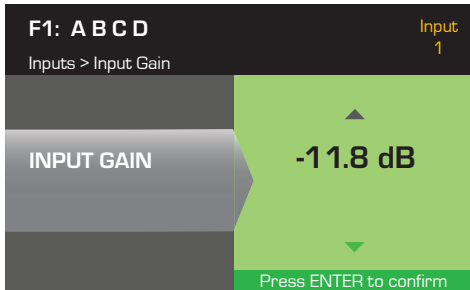

Scroll to select (-100 thru 20 dB)
(0.1 dB increments)

To confirm selection, press

To move to the next input, press

Repeat procedure for remaining input channels.

Set up the Outputs



NOTE: Changes made to outputs are in real time.

Source Select

The PLD amplifiers are equipped with an internal router that allows you to select the input sources for each of the four output channels.

- The default setting is Input 1 to Output A, 2 to B, 3 to C, and 4 to D.
- – Table 4 gives the possible input routings for a single output channel.

When you combine inputs, the input audio is summed equally to the output.

HOME > OUTPUTS > SOURCE SEL > ENTER

Step 1 – Select Input Source for each output channel

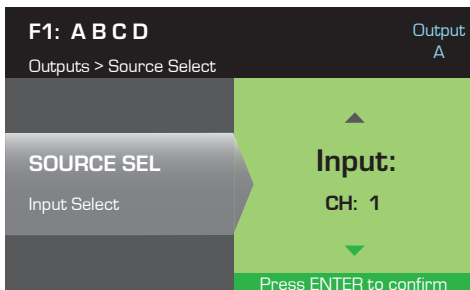

Scroll to select Input combination
(1), (1+2), (2), (2+3), (3), (3+4), or (4)

To confirm selection, press

To move to the next output, press

Repeat procedure for remaining input channels.

Input Routings						
1	1+2	2	2+3	3	3+4	4

– Table 4 –

Loudspeaker Processing

The Speaker Processing section allows you to make adjustments to the Crossover, EQ, Delay, Limiter, and QSC Array details for each output channel. In addition, you can load a pre-defined loudspeaker then make any adjustments needed, and save the changes as a user-defined loudspeaker. Depending on the loudspeaker selection, various parameters are not available for adjustment. When you make adjustments, you are making them in real time. If audio is passed while making changes, it is affected by the change.

The following instructions are not all in menu order, and all are optional. Repeat the following procedure for each output channel as necessary.

Load Speaker Profile

HOME > OUTPUTS > SPKR PROC > LOAD SPKR > ENTER

A loudspeaker profile includes all the DSP and loudspeaker characteristics available in the SPKR PROC section. When you LOAD a loudspeaker, you are loading all of the DSP and characteristics of that loudspeaker. You can start by loading a loudspeaker and then make modifications and save your new profile, or you can build the profile without loading a loudspeaker, and then save it as a new profile. If you load a QSC loudspeaker, the amplifier is set for that specific loudspeaker and some parameters may be locked out because they are set to their optimal value by the Intrinsic Correction Calculator, and should not be adjusted. The PLD supports a number of loudspeakers from other manufacturers. Refer to the list under "Included Loudspeaker Profiles" on page 26. There may be additions to this list in the future that can be loaded with firmware updates.



NOTE: If you make changes to any of the loudspeaker processing parameters, and then LOAD a loudspeaker profile, all the changes you made are overwritten.

Step 1 – Load an Existing Loudspeaker for the Selected Output

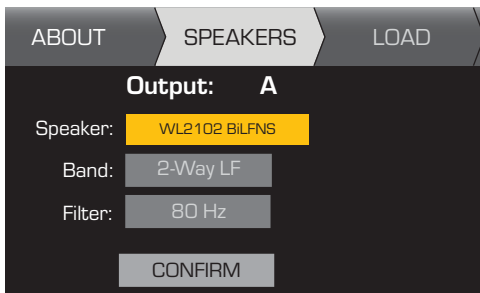

Band and Filter selections are displayed and constrained based on the loudspeaker.

To edit Speaker, press

Scroll to select Speaker model

To confirm, press

Scroll to (Band, Filter)

To adjust, press

Adjust selected parameter

To confirm, press

Scroll to LOAD

To Load the speaker profile to the selected output, press

Crossover

HOME > OUTPUTS > SPKR PROC > CROSSOVER > HIGH-PASS (OR LOW-PASS) > FREQ > ENTER

Step 1 – Set the Crossover High- and/or Low-pass filters

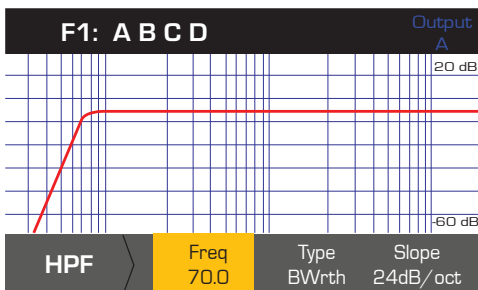

Freq: 20 - 20 kHz
Type:
• Butterworth
• Linkwitz-Riley,
• Bessel-Thomson
Slope:
6dB to 48dB/oct depending on Type

Scroll to select (Freq, Type, Slope)

To edit, press

Turn to adjust parameter

To confirm, press

To exit, press

HOME > OUTPUTS > SPKR PROC > CROSSOVER > GAIN/POL > GAIN > ENTER

Step 2 – Set the Crossover Gain and Polarity

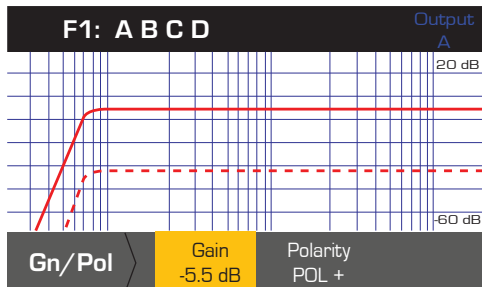

- Scroll to select (Gain or Polarity)
- To edit, press
- Turn to adjust parameter
- To confirm, press
- To exit, press

Parametric EQ

HOME > OUTPUTS > SPKR PROC > PEQ > BAND 1, 2, 3, 4, OR 5 > BAND BYPASS > ENTER

The graph is a composite of all five bands. Each band has a full range of 20 Hz to 20 kHz.

Step 1 – Set the Crossover EQ

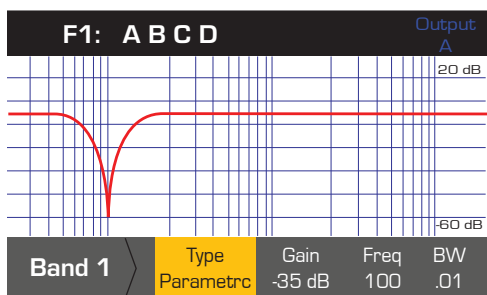

- Type: Bypass, Parametric, Low Shelf, High Shelf (Default Bypass)
- Gain: -40 to +20 dB (Default 0.00)
- Freq: 20 to 20kHz (Band 1 Def 100 Hz)
(Band 2 Def 500 Hz)
(Band 3 Def 1 kHz)
(Band 4 Def 2.5 kHz)
(Band 5 Def 5 kHz)
- BW: 0.01 to 3.00 Octive (Default 1.00 Oct.)

- Scroll to select (Type, Gain, Freq, BW)
- To edit, press
- Turn to adjust parameter
- To confirm, press
- To exit, press

Delay

HOME > OUTPUTS > SPKR PROC > DELAY > DELAY TIME > ENTER

Step 1 – Set the Output Delay Time

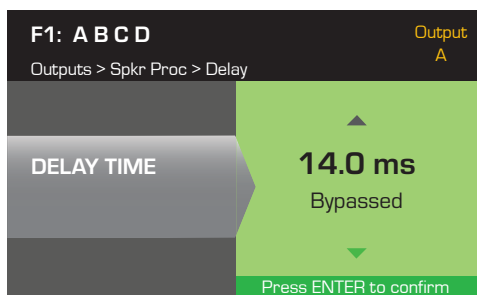

- Delay: 0.0 ms to 50.00 ms
1.0 ms increments
- Bypass: Bypassed or Enabled

- Scroll to (Delay Time or Bypass)
- To edit, press
- Turn to adjust parameter
- To confirm, press
- To exit, press

Limiter

HOME > OUTPUTS > SPKR PROC > LIMITER > ENTER

Step 1 – Set the Limiter Mode

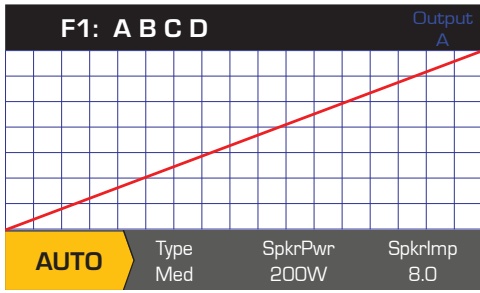

To edit the Limiter mode, press 

Turn to select the mode for the Limiter 



To confirm setting, press 

HOME > OUTPUTS > SPKR PROC > LIMITER > AUTO



NOTE: SpkrPwr maximum output depends on the amplifier and the output configuration you select. The maximum for separate channels is 1250 W, a single combined channel (ABCD or AB+CD) can be up to 5000 W depending on the amplifier.

Step 2 – Set the AUTO Mode Parameters

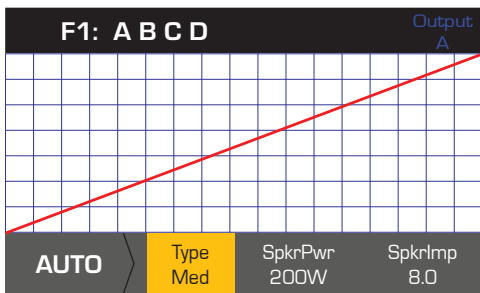

Type:
Aggressive
Medium
Mild

SpkrPwr:
10.0 W to 1250 KW

SpkrImpd:
2.0 Ω to 32.0 Ω

Scroll to select (Type, SpkrPwr, SpkrImp) 

To edit, press 

Turn to adjust parameter 

To confirm, press 

To exit, press 

Type - the Auto Limiter Type is a protection level and its values are, Mild, Medium and Aggressive. This Type parameter, along with the Power Rating and Impedance drive an algorithm designed to maximize the performance of your loudspeakers. They set the RMS and Peak threshold values as well as their attack and release setting.

SpkrPwr - if a single speaker is being driven, the SpkrPwr should be the continuous power rating of that loudspeaker. If multiple speakers are being driven this value should be the combined power rating for the load.

SpkrImp - if a single speaker is being driven, the SpkrImp should be the nominal impedance of that loudspeaker. If multiple speakers are being driven this value should be the combined impedance for the load.

HOME > OUTPUTS > SPKR PROC > LIMITER > ADV

Step 3 – Set the ADV Mode Parameters

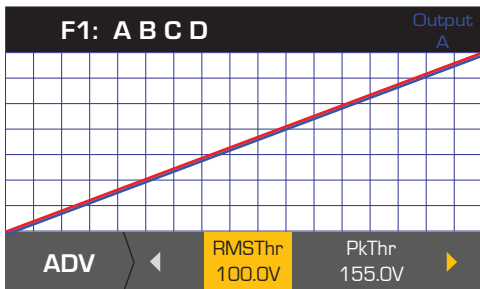

RMSThr: 3.0V to 100.0V

PkThr: 5.0V to 155.0V

PkAttk: 0.10 ms to 20.0 ms

PkRel: 1.00 ms to 1.0 s

RMSAttk: 0.05 s to 10.0 s

RMSRel: 1.0 s to 60.0 s

Scroll to select (RMSThr, PkThr, PkAttk, PkRel, RMSAttk, & RMSRel) 

To edit, press 

Turn to adjust parameter 

To confirm, press 

To exit, press 

Thr = Threshold, Pk = Peak, Attk = Attack, Rel = Release

Array Correction



NOTE: You must have a QSC line array loaded in order to access the Array Correction parameters.

HOME > OUTPUTS > SPKR PROC > ARRAY > ENTER

Step 1 – Set Splay Angle and Number of Boxes in the Array

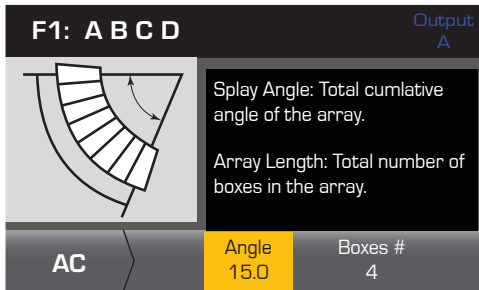

Angle:
0.0° to 90.0°

Boxes #:
0 to 20

Scroll to select (Angle or Boxes#)

To edit, press

Turn to adjust parameter

To confirm, press

To exit, press

Save a Loudspeaker

HOME > OUTPUTS > SPKR PROC > SAVE SPKR > ENTER

When you Save a speaker profile, you are saving all of the output settings currently active for the channel. The new profile you save does not need to be Loaded, it is already active.

Step 1 – Save a Loudspeaker with Custom Load Profile

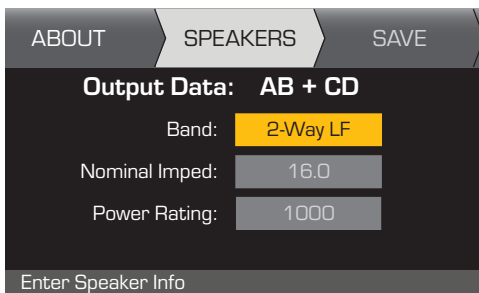

Nominal Impedance and Power Rating are the nominal settings for a single loudspeaker of this type.

Scroll to select (Band, Nominal Imped, Power Rating)

To edit, press

Turn to adjust parameter

To confirm, press

After confirming settings, Scroll to SAVE

Step 2 – Name the Loudspeaker Profile

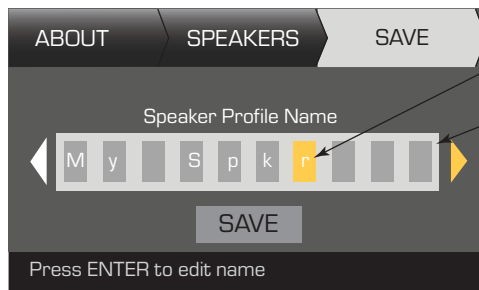

Indicates editing

Indicates "Speaker Profile Name" is selected

Up to 21 characters
A-Z / a-z / 0-9 /
_ / - / space

To add Speaker Profile Name, press

Scroll to desired letter position press

Turn to select desired character press

When finished, scroll to SAVE press

Save the Preset

After modifying the Inputs and Outputs for all channels, save the current settings as one of the 50 user-defined presets (U1: thru U50:). Each of the user presets, by default, is the same as factory preset F1: Config A B C D, so when you save the preset you are "overwriting" the preset currently in that numbered position. If you started by recalling a factory preset, you must use the SAVE AS feature. If you started with a user-defined preset, you can overwrite the preset you started with using the SAVE feature, or use the SAVE AS feature to overwrite a different user preset.

HOME > PRESETS > PRESET > SAVE > SAVE AS > ENTER

Step 1 – Save a New Preset - Select and Edit Preset Number



To edit User Preset number, press

Turn to select desired number (1 thru 50)

To confirm User Preset Number, press

Step 2 – Name the Preset



Indicates editing

Indicates "New Preset Name" is selected

Up to 21 characters
A-Z / a-z / 0-9 /
_ / - / space

Scroll to New Preset Name press

Scroll to desired letter position press

Turn to select desired character press

Step 3 – Save the Preset



When you are finished naming, press

Scroll to SAVE

Press

To confirm Save, press

HOME > PRESETS > PRESET SAVE > SAVE > ENTER

Use this procedure when you are saving the preset by overwriting the currently active user preset. After you use the SAVE AS feature to save the preset you are working on, it then becomes the currently active preset, and you can use the SAVE feature to save periodically as you work on the preset.

Step 1 – Overwrite Preset

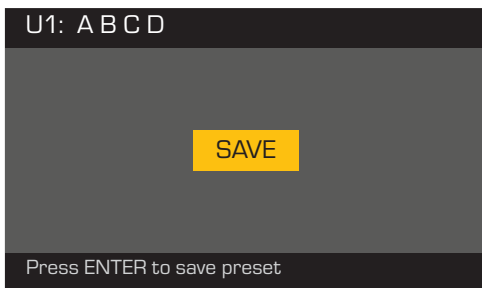

To save, press

To exit without saving, press

To confirm the save, press

Utilities

HOME > UTILITIES > STATUS > ENTER

Step 1 – Check the amplifier's health

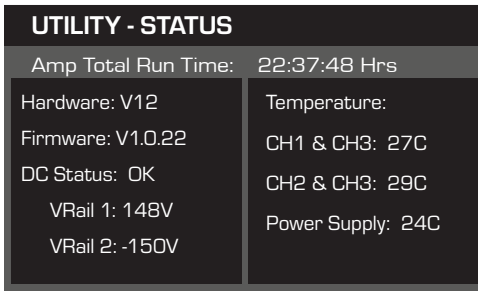

Amp Total Run Time:
HH:MM:SS

Hardware version

Firmware version
update thru Amplifier Navigator

DC Status:
VRail 1 = +147VDC +/- 5V typical
VRail 2 = -147VDC +/- 5V typical

Temperature (PLD 4.3 & 4.5)
Thermal Limiting starts at 69°C
Thermal Shutdown at 80°C

HOME > UTILITIES > AMP ID > ENTER

Step 2 – Name the Amplifier

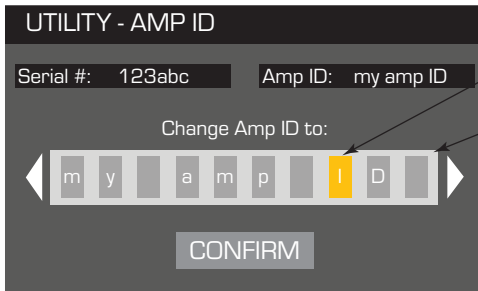

Indicates editing

Indicates "New Preset Name" is selected

Up to 21 characters
A - Z / a - z / 0 - 9 /
_ / - / space

To edit "Change Amp ID to:", press

Scroll to desired letter position press

Turn to select desired character press

When you are finished, press

Scroll to CONFIRM

Press

HOME > UTILITIES > PASSWORD > ENTER

The default password for all amplifiers is **QSC** - all uppercase. The password is case sensitive, can be up to 10 characters long, and contain, **A - Z a - z 0 - 9 _ - space**

Step 1 – Add or change the Password

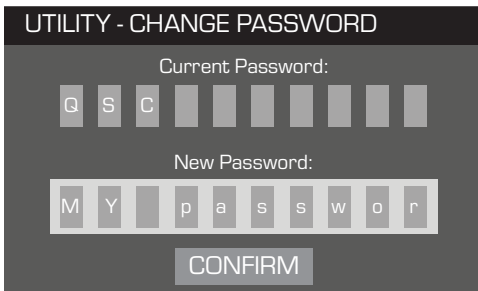

To enter "Current Password:", press

With the first letter position selected, press

Turn to select desired character press

When you complete the current password, the "New Password:" is automatically selected
Repeat the procedure for the "New Password:"

Scroll to CONFIRM

Press

HOME > UTILITIES > LOCKOUT > ENTER

All controls are locked except the Mute buttons, the front-panel and rear power buttons, the Enter button and Master Control knob to unlock the amplifier.

Step 2 – Enter Password to lock or unlock

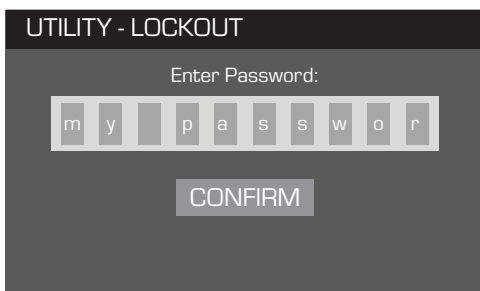

With "Enter Password:" selected, press

With the first letter position selected press

Scroll to desired character press

When you complete the password correctly, CONFIRM is automatically selected.

To lock or unlock the amplifier, press

Included Loudspeaker Profiles

QSC Audio

AP-5102
AP-5122
AP-5122m FOH
AP-5122m MON
AP-5152
GP118-sw
GP212-sw
GP218-sw
S8T
S10T
S12
WL118-sw
WL-2102
WL212-sw
WL218-sw

B52

LX1515V3
LX18V3
MX1515
MX18S

Cerwin-Vega (CV)

EL-36C
TS-42

EV

ELX112
ELX115
ELX215
TX2152
TX2181

JBL

JRX112M
JRX115
JRX118S
JRX125
MRX515
MRX518S
MRX525
MRX528S
PRX415M
PRX425
SRX712M
SRX715
SRX718S
SRX722
SRX725
SRX728S
SRX738
VRX932LA

Peavy

PR10
PR12
PR15
PV115
PV118
PV12M
PV215
PVX12
PVX15
SP218
SP4

Yamaha

BR12
BR12M
BR15
C115V
S115V
S215V
SM15V
SW218V

Specifications

	PLD4.2	PLD4.3	PLD4.5
4 Ch. Continuous ¹			
8Ω	400 Watts	625 Watts	1150 Watts
4Ω	400 Watts	625 Watts	1250 Watts
2Ω	325 Watts	625 Watts	625 Watts
2 Ch. Continuous ¹			
8Ω	800 Watts	1250 Watts	2250 Watts
4Ω	800 Watts	1200 Watts	2250 Watts
2Ω	650 Watts	1200 Watts	2100 Watts
1 Ch. Continuous ¹			
8Ω	1600 Watts	2500 Watts	4200 Watts
4Ω	1600 Watts	2500 Watts	4200 Watts
2Ω	1600 Watts	2500 Watts	4250 Watts
1Ω	1600 Watts	2500 Watts	3700 Watts
Typical Distortion			
8Ω	0.01 - 0.03%	0.01 - 0.03%	0.01 - 0.03%
4Ω	0.03 - 0.06%	0.03 - 0.06%	0.03 - 0.06%
Maximum Distortion			
4Ω - 8Ω	1.0%	1.0%	1.0%
Frequency response (8Ω)	20 Hz - 15 kHz +/- 0.2 dB 20 Hz - 20 kHz +0.2 dB / -0.7 dB	20 Hz - 15 kHz +/- 0.2 dB 20 Hz - 20 kHz +0.2 dB / -0.7 dB	20 Hz - 15 kHz +/- 0.2 dB 20 Hz - 20 kHz +0.2 dB / -0.7 dB
Noise			
Unweighted Output Unmuted	-101 dB	-101 dB	-101 dB
Weighted Output Muted	-109 dB	-109 dB	-109 dB
Gain (1.2V setting)	34.0 dB	38.4 dB	38.4 dB
Damping factor	>150	>150	>150
Input impedance	>10k, balanced or unbalanced	>10k, balanced or unbalanced	>10k, balanced or unbalanced
Maximum input level			
(3.9V setting)	12.28V (+24 dBu)	12.28V (+24 dBu)	12.28V (+24 dBu)
(1.2V setting)	3.88V (+14 dBu)	3.88V (+14 dBu)	3.88V (+14 dBu)
Controls and indicators (front)	Power • Channel MUTE Buttons • Channel SELECT Buttons • Channel Input Signal and CLIP LED Indicators • Channel Output and LIMIT LED Meters • HOME, ENTER, EXIT, GAIN Navigation Buttons • Control Knob		
Controls and indicators (rear)	AC Power Disconnect	AC Power Disconnect	AC Power Disconnect
Input connectors	Female XLR	Female XLR	Female XLR
Output connectors	NL4	NL4	NL4
Amplifier and load protection	Short circuit, open circuit, thermal, RF protection. On/Off muting, DC fault shutdown, active inrush limiting, input current limiting		
AC Power Input	Universal Power Supply 100 - 240 VAC, 50 - 60 Hz		
Dimensions (HWD)	3.5" x 19" x 12" (89 x 482 x 305 mm)	3.5" x 19" x 16" (89 x 482 x 406 mm)	3.5" x 19" x 16" (89 x 482mm x 406mm)
Weight, Net / Shipping	18.5 lb (8.4 kg) / 22 lb (10.0 kg)	21.0 lb (9.5 kg) / 25 lb (11.3 kg)	22.0 lb (10.0 kg) / 26 lb (11.8 kg)

1 - 1.0 kHz sine wave, 1% THD, 1 channel driven

Heat Loss Charts

	BTU/hr	kcal/hr
Idle		
PLD 4.3	225	57
PLD 4.5	286	72

Load per Channel	8Ω		4Ω		2Ω	
	BTU/hr	kcal/hr	BTU/hr	kcal/hr	BTU/hr	kcal/hr
1/8th Power						
PLD 4.3	684	172	794	200	1040	262
PLD 4.5	811	204	1144	288	1124	283
1/3rd Power						
PLD 4.3	983	248	1261	318	1869	470.988
PLD 4.5	881	222	1708	430	1737	438
Full Power						
PLD 4.3	2498	629	2925	737	4198	1058
PLD 4.5	3116	785	5318	1340	4208	1060

Idle

Thermal loss at idle or with very low signal level.

1/8 Power

Thermal loss at 1/8 of full power is measured with pink noise. It approximates operating with music or voice with light clipping and represents the amplifier's typical "clean" maximum level, without audible clipping. Use these figures for typical maximum level operation.

1/3 Power

Thermal loss at 1/3 of full power is measured with pink noise. It approximates operating with music or voice with very heavy clipping and a very compressed dynamic range.

Full Power

Thermal loss at full power is measured with a 1 kHz sine wave. However, it does not represent any real-world operating condition.

NOTE: Specifications are subject to change without notice.



Mailing Address:

QSC Audio Products, LLC
1675 MacArthur Boulevard
Costa Mesa, CA 92626-1468 USA

Telephone Numbers:

Main Number: (714) 754-6175

Sales & Marketing: (714) 957-7100 or toll free (USA only) (800) 854-4079

Customer Service: (714) 957-7150 or toll free (USA only) (800) 772-2834

Facsimile Numbers:

Sales & Marketing FAX: (714) 754-6174

Customer Service FAX: (714) 754-6173

World Wide Web:

www.qsc.com

E-mail:

info@qscaudio.com

service@qscaudio.com