



PRODUCT CATALOG & BUYER'S GUIDE

PM-114



PVC-Coated Rigid Metal Conduit, Fittings, and Accessories



Table of Contents

STATEMENT OF ACCURACY

The information published in this catalog and other literature has been compiled with great care and is sufficiently accurate for most purposes but is not guaranteed. The product information in this catalog, though current at the catalog printing, is subject to improvements and modifications. All statements, technical information and recommendations contained herein are based on information and tests we believe to be reliable. This catalog and the products contained within is subject to change without notice. The purchaser should determine the suitability of the product for his or her application and assumes all risk and liability whatsoever in connection therewith.

Robroy products are covered by issued patents and additional patents may be pending.
Robroy Industries values and protects its intellectual property.
For more information please visit: PermaCote.com/Patents

Perma-Cote is manufactured and distributed by Robroy Industries, USA, ISO 9001-certified. Perma-Cote complies with all standards mandated by UL 6, NEMA RN-1, ANSI C80.1, ETL PVC-001, IEC IP69/UL Type 4X and UL 1203 Hazardous Location. Patented SIB.

Industrial-Strength Corrosion Protection	2	LTR Combination Couplings	44
The Degree of Difference	3	TECK Series Cable Fittings	45
Did You Know?	9	Grounding Bushings	46
Resources for Safety and Success	9	Split Couplings	46
Listings and What They Mean	10	Reducing Bushings	47
Installation Tips	12	Reducing Couplings	48
Training	14	Plugs	49
PVC-Coated Conduit	15	Conduit Expansion Joints	50
Nipples	16	Service Entrance Elbows	51
PVC-Coated Elbows	18	Malleable Elbows	52
PVC-Coated Couplings	20	Conduit Unions	53
PVC-Coated SpeedCouple	21	GUA Series Outlet Boxes	54
PVC-Coated Sealing Locknut	22	Sealing Fittings	58
Cast Device Boxes	23	Sealing Compounds	63
Cast Device Boxes – Single Gang	24	ECGJH and ECLK Series Couplings	64
Cast Device Boxes – Two Gang	28	OE Series Outlet Boxes	66
Cast Device Box Covers	29	Support Products	67
Conduit Bodies and Covers	31	Stainless Steel Accessories	74
LBD Pulling Elbows	36	Installation Tools	83
Mogul Style Conduit Bodies	37	Installer Certification	84
Knockout Hubs	40	Lower Your Project Risks and Costs	85
Liquid Tight Connectors	42	Technical Information	86

INDUSTRIAL-STRENGTH CORROSION PROTECTION

PERMA-COTE PVC-COATED CONDUIT, FITTINGS, AND ACCESSORIES

Corrosion doesn't stand a chance when you install Perma-Cote's comprehensive line of PVC-coated rigid metal conduit and fittings to provide proven, maximum protection for electrical raceway systems in demanding and harsh environments.

Perma-Cote's PVC-coated conduit system creates a complete corrosion barrier, with PVC on the outside and urethane on the inside.



PUT PERMA-COTE PVC-COATED CONDUIT AND FITTINGS TO WORK

The strength of Perma-Cote's comprehensive line of products makes it the perfect solution for a broad range of industries where risk of corrosion to electrical raceways could result in costly, catastrophic damage; creating downtime, safety, legal, and environmental concerns.

INFRASTRUCTURE

- Airports
- Bridges
- Transportation

INDUSTRIAL

- Chemical
- Food & Beverage
- Mining
- Pharmaceutical

- Petrochemical
- Power Plants
- Pulp & Paper
- Water & Wastewater

COMMERCIAL

- Campus
- Fuel Station
- Parking Lot



The Degree of Difference

You can depend on Perma-Cote to meet full compliance for your project and provide an unmatched level of safety and performance.

Perma-Cote is ISO 9001-certified manufactured and distributed by Robroy Industries, a pioneer and industry leader, originally founded in 1905. Robroy Industries has been innovating corrosion protection for over 100 years and was the first company to produce PVC-coated products in 1967.

ETL VERIFICATION

Perma-Cote's PVC-coated, rigid galvanized metal conduit is UL 6 listed for safety and ETL PVC-001 verified, validating interior and exterior coating performance and predictability of service life longevity – at least 10X longer than other brands that do not carry the ETL-verified listing.

Testing for ETL PVC-001 is not intended to replicate a specific environment. Rather, it is designed to predict the service life of a coating under the two most common conditions that affect adhesive bonds: heat and humidity. Perma-Cote consistently earns its ETL PVC-001 label on a quarterly basis by repeatedly and successfully passing the stringent performance tests required for verification.

ADHESION ENHANCEMENT PROCESS

Perma-Cote's unique Adhesion Enhancement Process (AEP) removes oxidation, white rust, and contaminants from the conduit's outer zinc surface without harm or deterioration and readies it for maximum bonding, maintaining all industry standards and conformances.

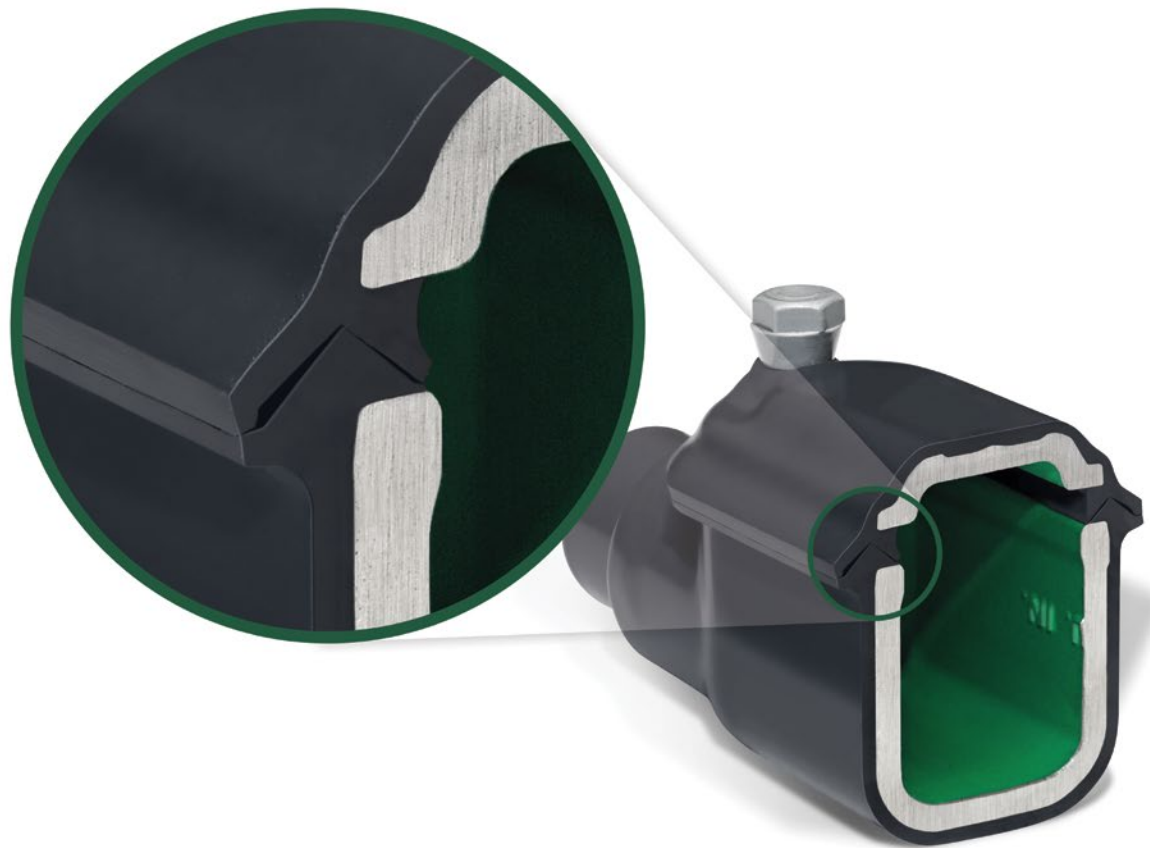

FORM 8 AND MARK 9 FITTINGS

One of the key benefits of Perma-Cote Form 8 and Mark 9 fittings is our patented V-Seal® gasket with a special interlocking groove, providing the most effective seal for PVC-coated Form 8 (Feraloy® iron alloy and aluminum) and Mark 9 bodies. In addition, Form 8 and Mark 9 fittings carry the UL Type 4X and IEC IP69 rating (tested to DIN Standard IP69K), meeting the highest protection rating on the scale and providing defense against ingress of dust, water, and other foreign matter.

Testing for IP69 includes a set of tests to certify ingress protection against both solids and liquids. The dust test is conducted in a closed dust chamber containing 2 kg/m³ of suspended talcum powder particles of 50-µm diameter or less. The powder is circulated 8 hours at a rate sufficient to cycle the volume of powder present at least 60 times.

In order to bear an IP69 label for protection from water intrusion, the water jetting test is conducted by placing the fitting on a turntable that rotates every 12 seconds (5 rpm) and spraying 176°F (80°C) water from 4-6 inches at a flow rate of 4 gallons per minute. Water is sprayed at angles of 0, 30, 60, and 90 degrees for 30 seconds each. Products tested to the IP69k standard undergo water pressure of 1160-1450 psi throughout the testing procedure. The product provides the most complete protection against water ingress in washdown environments.

SEALING LOCKNUT

Exposed conduit threads at points of connections in your electrical system are the weakest link in any conduit system and can lead to potential corrosion issues. Perma-Cote Sealing Locknuts cover exposed threads and provide protection against harsh environments. The simply designed detachable sleeve provides a consistent seal over exposed conduit threads and is easy to install and tighten. This is especially useful in transitioning from PVC to PVC-coated GRC or items that are unable to be coated (i.e. firebox or motor).

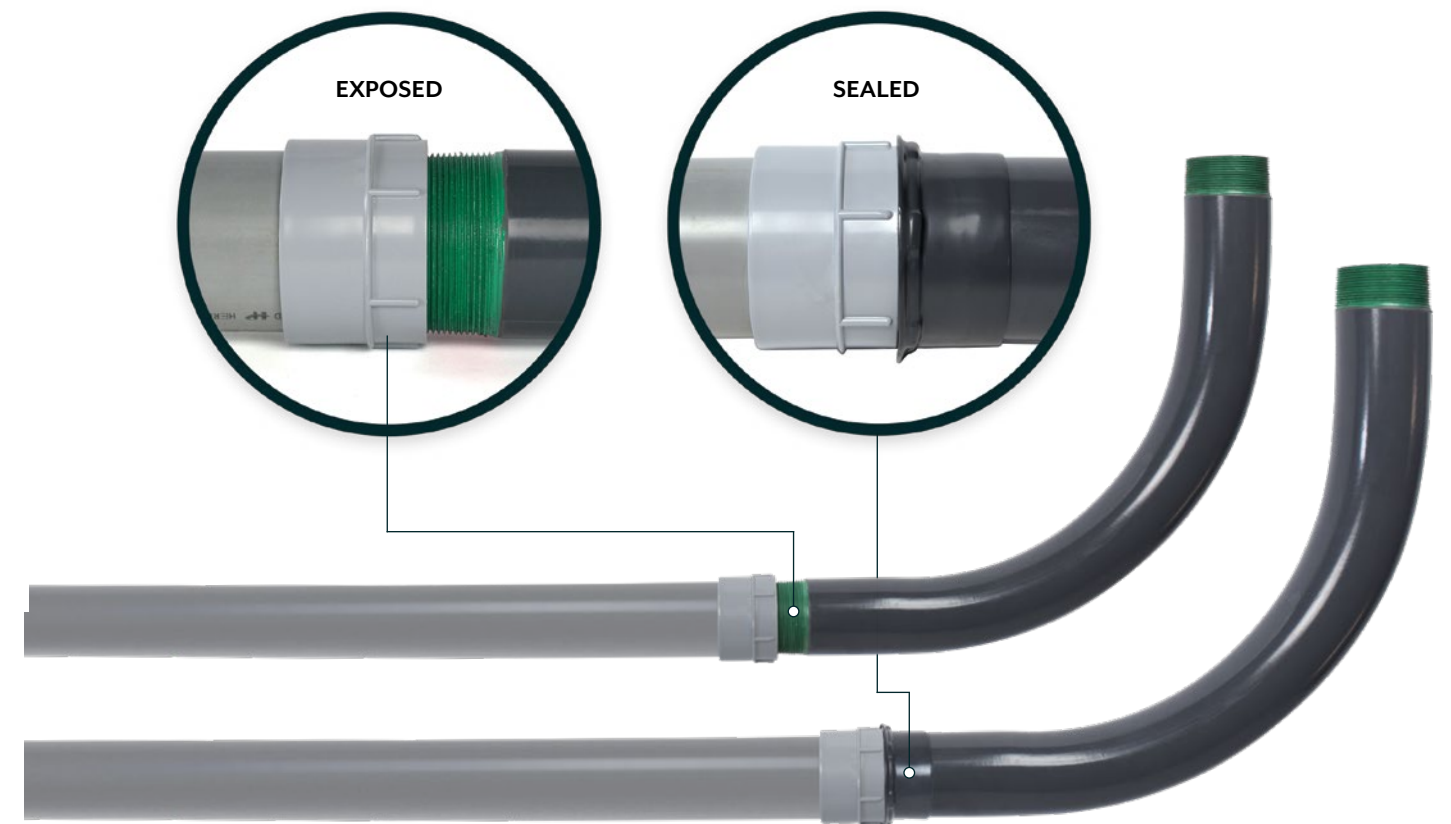

PVC-COATED SPEEDCOUPLE

The simplified installation of Perma-Cote's new PVC coated SpeedCouple is ideal for applications with limited space or where turning conduit or elbows may be difficult, saving time and money.

SpeedCouple is concrete tight and suitable for direct burial. This makes it a preferred choice for duct bank applications where groups of conduit protect and consolidate cabling. It is available in trade sizes 2" through 6".



The Degree of Difference

P5SA™ PLUG 5 SAFETY ASSURANCE

Our patented P5SA™ validation system, available on sealing fittings, provides additional assurance to installers and inspectors that Perma-Cote urethane-coated plugs are correctly engaged the first time, every time with visual confirmation.

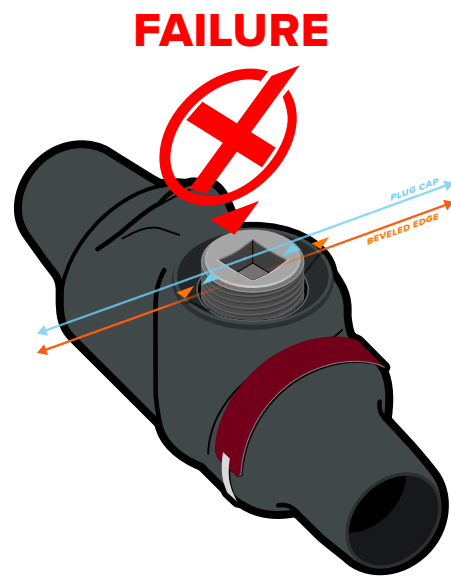

SUCCESS

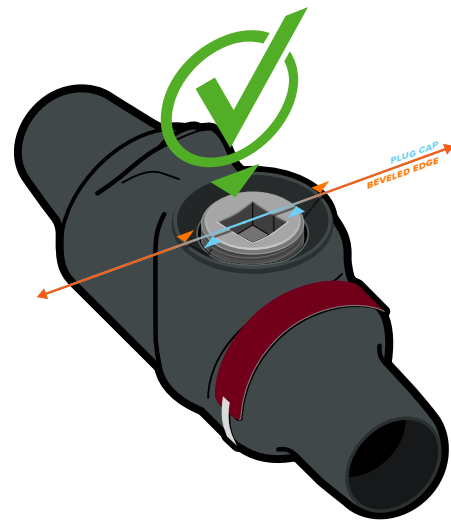

ENHANCED AND SMART UL CERTIFICATION MARK AND BADGE SYSTEM

Convenient QR codes make it easy for contractors and inspectors to scan Perma-Cote products on site, giving you immediate access to vital information about the product and certification compliance from the UL Smart Marks hub.

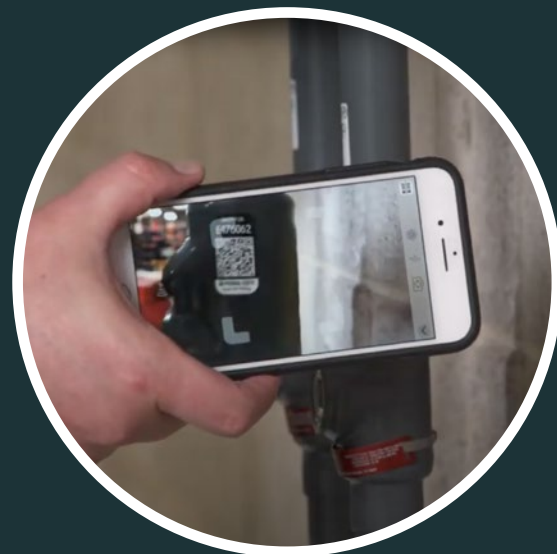

UL 1203 HAZARDOUS LOCATION LISTED FITTING

Perma-Cote's PVC-coated hazardous (classified) location fittings (sealing fittings, conduit unions, GUA outlet boxes, and EC series flexible couplings) are UL 1203 Listed for safety, **AFTER THE COATING IS APPLIED**, providing customers with the safest and best performing corrosion-resistant solutions. PVC-coated products that are UL 1203 Listed are easily identifiable by the red metal tag attached.



Always ensure you are using UL Listed hazardous location fittings. Simply stated, if there is no UL label, that product is NOT UL Listed.



PVC COATING REPAIR KIT

Our PVC Coating repair kit is a UL-recognized, two-part epoxy formulated to bond to steel, aluminum, and PVC substrates, and has been tested for safety of flame propagation. Repairing damage to exterior PVC Coating immediately improves the exterior's appearance and helps to maintain the product's integrity and corrosion resistance. Kit includes all tools necessary for a quality repair, along with other instructions and chemical information.

HOT GALVANIZED THREADS

After machining of conduit threads to exacting tolerances, Perma-Cote conduit threads are further enhanced utilizing a specialized hot galvanizing process that protects the threads. Perma-Cote threads are coated with a clear polyurethane spray to provide additional corrosion protection. This process allows for zinc to be evenly applied to the threads, keeping zinc from pooling inbetween threads. In addition, threads are not over-exposed to molten zinc. This prevents threads from becoming brittle.

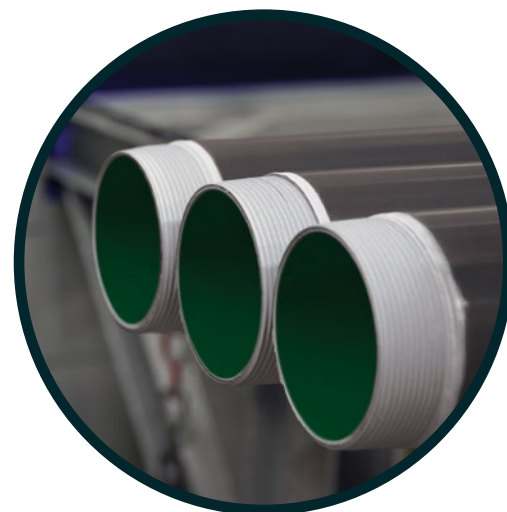

WHY WE USE DARK GRAY FOR THE EXTERIOR OF OUR PERMA-COTE PRODUCTS?

Simple, it's all about performance. Our specially formulated gray plastisol offers long-term UV resistance and prevents deterioration when exposed to elements in the environment. It also remains more flexible over time opposed to other colors that may cause premature failure of the protective coating. Color also affects the coating's flammability level and conductivity, important to static discharge.

Do you need a custom color? For options, contact Perma-Cote at (903) 843-4388 or email us at CSR@Robroy.com.

NEED HELP WITH YOUR SPECIFICATION?

For assurance of the right products for safety and performance installed by trained professionals, Perma-Cote offers a complimentary specification reviewing service.

To learn more, contact us at (903) 843-4388 or email CSR@Robroy.com.

DIFFERENCE BETWEEN BUY AMERICAN AND BUY AMERICA

Buy American Act – Typically applies to purchases by the federal government being directly purchased for federal buildings or facilities (such as U.S. highways). Requires 51% of the final product components to be made in the U.S.

Buy America Act – Generally applicable to state and local government projects, typically when funded by the Federal Transit Authority (FTA). Requires 100% of the supply components or construction materials to be made in the U.S.

Traditional Perma-Cote products comply with Buy American Act. If your project requires the use of 100% domestic product, please let us know at the time of the quote so we can accommodate. Upon request, domestic certifications can be provided at time of order.

DO YOU HAVE A REQUIREMENT FOR A PRODUCT THAT YOU DO NOT SEE IN OUR CATALOG?

Perma-Cote can provide custom coating for most electrical fittings and raceway materials. To learn more, please contact us at (903) 843-4388 or email your inquiry to CSR@Robroy.com.

Resources for Safety and Success

Perma-Cote's commitment to the safe, successful installation and use of its product line is backed by a wealth of resources, training, and support. To learn more about our convenient installation training and Corrosion College classes, see Page 14.

SAFETY DATA SHEETS

SDS sheets provide comprehensive information on hazardous chemical properties. For the latest up-to-date SDS sheets go online to PermaCote.com/SDS.

PROPER MATERIAL HANDLING

The best way to prevent product damage is to be knowledgeable about proper handling techniques. For a video overview on proper material handling of Perma-Cote products, go to PermaCote.com/MaterialHandling.

Listings and What They Mean



NEMA RN 1 (NATIONAL ELECTRICAL MANUFACTURERS ASSOCIATION)

This industry best practice standard covers continuous PVC exterior coatings, corrosion resistant interior coatings, and galvanized steel conduit, along with couplings and elbows. It states conduit must follow ANSI C80.1 and UL 6. NEMA RN 1 provides properties and dimensions of coating and is intended as an aid for selecting proper coating.

It also sets guidelines for post cutting/threading protective coatings, thickness of PVC, and requirements for each ASTM testing method – hardness, tensile strength, elongation, dielectric strength, brittleness temperature, abrasion resistance, bendability, and artificial weathering. NEMA RN 1 states best practices for cleanliness of conduit, proper use of primer for adhesion, and workmanship/appearance (finish shall be free of blisters, bubbles, and pinholes). Standards also set protocol for PVC adhesion pull test (bond stronger than PVC).



ETL PVC-001

ETL SEMKO, a division of Intertek, specializes in electrical product safety and performance testing. ETL, along with UL and CSA, are the three major laboratories operating in the U.S. that have been certified by the Occupational Safety and Health Administration (OSHA) as a Nationally Recognized Testing Laboratory (NRTL).

Carrying the ETL Verified Mark indicates to consumers that a product has met certain design and performance standards as confirmed through independent testing and periodic follow-up inspections.

ETL PVC-001 signifies compliance to the Intertek SEMKO High Temperature H2O PVC-Coating Test Procedure for predicting service (200 hours), in accordance with ASTM B870 and ASTM D2247.

ANSI C80.1 (AMERICAN NATIONAL STANDARDS INSTITUTE)



Under the guidelines and represented by NEMA, ANSI C80.1 aims to set consistency in the manufacturing of electrical conduit. Length, circular cross sections, wall thickness, surface specs, cleaning, welding, zinc coating, threading, and identification are all covered.

The standard also sets guidelines for inspection and incorporates additional testing procedures – ductility of steel, ductility of zinc coating, thickness of coating, and quality of enamel coating of interior surfaces.

UL (UNDERWRITERS LABORATORIES)



UL 6 is the Standard for Safety for Electrical Rigid Metal Conduit – Steel. This includes elbows, couplings, and nipples for use as a metal raceway for installation of wires and cables and is the common ANCE, CSA, and UL standard in accordance with CSA C22.1, Canadian Electrical Code, Part I, NOM-001-SEDE, Standard for Electrical Installations, and NFPA 70, National Electrical Code.

UL 6 references requirements for material properties, dimensions, and testing to evaluate zinc coating protection for ERMC-S. Supplementary nonmetallic coatings undergo tests involving flame propagation, coupling fit, and electrical continuity with coupling. If PVC is listed as primary corrosion protection, it must also undergo salt-spray (fog), water, moist carbon dioxide-sulfur dioxide-air, and ultraviolet light tests, as well as cold impact, tensile strength, and adhesion tests.

Electrical conduit also covered by UL 6A includes Standard for Safety for Electrical Rigid Metal Conduit – Aluminum, Bronze, and Stainless Steel; UL 797 & 797A - Electrical Metallic Tubing; and UL 1242 - Electrical Intermediate Metal Conduit.

Additionally, fittings and hardware are covered by UL 514B, Standard for Safety for Fittings for use with Cable and Conduit, UL 514A and 514D - Metallic Outlet Boxes and Cover Plates for Flush-Mounted Wiring Devices (Aluminum including), UL 467 - Grounding and Bonding Equipment, and UL 2239 - Hardware for the Support of Conduit, Tubing, and Cable.

UL 1203 is the UL Safety Standard for Explosion-Proof and Dust-Ignition-Proof Electrical Equipment for Use in Hazardous (Classified) Locations. Some of the most common locations that require product ratings for explosion and dust-ignition protection are also those located in corrosive environments. UL 1203 evaluates both the construction and performance of enclosures and fittings for use in hazardous classified locations along with the additional criteria of protection against corrosion.

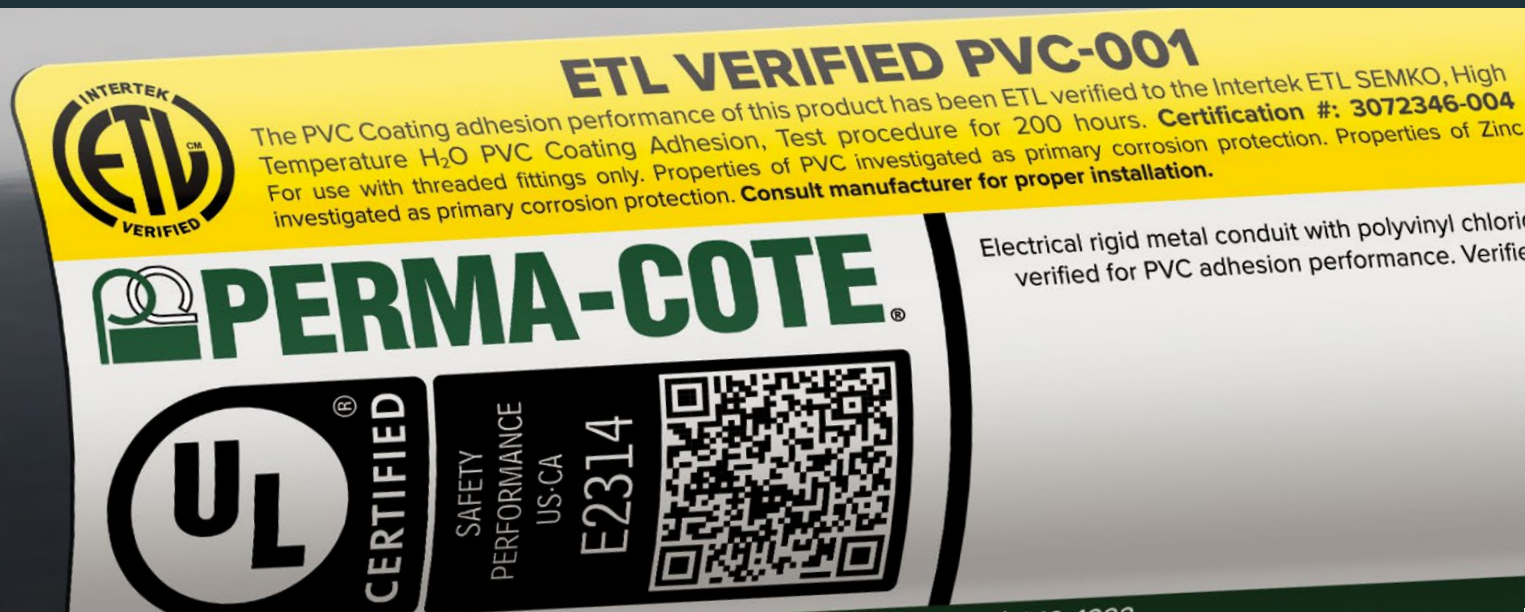



CLAMPING

When using a yoke style pipe vise, replace the jaw assembly with special vise adapters. When using a chain vise for conduit, use half-shell clamps to clamp a 2-inch or larger diameter PVC-coated conduit. If you use a power unit that spins the conduit, equip the chuck with inserts designed for use with coated conduit.

CUTTING

A roller cutter is recommended for cutting PVC-coated conduit. This will make a square cut end and remove about 1/4" of PVC coating that aids in threading the conduit. If using a band saw, make sure the cut is square before threading can occur.

Cutting away 1/4" of the exterior coating in the same manner as sharpening a pencil allows the pipe guide to ride up and over the PVC coating, facilitates coating removal, and enables cutting the thread in one operation. A reamer is used to remove any rough internal edges caused by cutting to prevent insulation damage during wire pulling.

THREADING

Before threading, make a series of cuts in the PVC along the longitudinal axis of the conduit, using the thread protector attached to the end of each conduit section to gauge the length. These cuts help remove the PVC in small pieces rather than long strips that can foul the die head and cause the conduit to collapse. Before threading, machine the stationary guide to remove 0.12 inch so the pipe guide can ride up and over the PVC coating, or purchase die heads that are specifically designed for PVC-coated conduit. Always use a new die head to thread coated aluminum. Using the same die head to thread PVC-coated aluminum and coated rigid steel conduit is not recommended.

After threading, clean the threads and conduit interior with a degreasing spray to prepare for the application of the thread compound. Cleaning ensures proper adherence of compound to the unprotected metal substrate.

HYDRAULIC BENDING

For best results, use equipment designed to bend coated conduit. Hydraulic and electric powered benders are available with shoes sized for coated conduit. When bending coated conduit, use rubbing alcohol to clean the inside of the shoe and the area of conduit you wish to bend.

Never use lubricant in the shoe or on the conduit. Lubricant allows the conduit to slip above the centerline of the shoe, resulting in flattening of the elbow.

Conventional shoes can be used to bend conduit if 0.06 inches are removed from the inside surface to accommodate the coating thickness.

HAND BENDING

When using a conventional hand bender, use the next larger size bending shoe to allow space for the coating. You can make hand bends with a special coated bending hickey that reduces damage potential to the coating when making sharp bends, saddles, or offsets. Installers typically use these tools for 1/2" to 3/4" diameter conduit.

ASSEMBLY

You should use special Z-Wrenches in lieu of standard adjustable pliers to assemble PVC-coated conduit and fittings. Z-Wrenches spread the clamping force and enable the tool to grip securely without damaging the conduit coating. Strap wrenches can be used to tighten conduit or couplings without damaging the coating.

For smaller conduit sizes, Spin-It tools are available for use with air impact or standard ratchet wrenches to assemble the conduit and fittings faster than conventional methods. This method never touches the PVC coating and saves time by eliminating the need to touch up damage marks.

Special sockets are available for use with ratchets to tighten encapsulated screws on conduit fittings, hangers, and clamps.

PVC sleeves on conduit couplings and fittings help isolate corrosives from the threads at joints. Typically, the sleeves should not be cut; however, it may become necessary to remove portions of the sleeve when the fitting is close to other sleeves, such as with a short nipple. In this instance, cut away half of each sleeve and apply touch-up compound to the joints.



CORROSION COLLEGE

This is a two-day, hands-on short course that provides proven solutions for the prevention of industrial corrosion through classroom and actual experience. Corrosion College is accredited for 15 Professional Development Hours (PDHs) through Texas A&M, Purdue University, Kilgore College, American Institute of Architects, and PDH Engineer. For more information, contact Corrosion College at (903) 843-3461 or CorrosionCollege@Robroy.com.



LUNCH AND LEARNS

These learning opportunities are aimed directly at educating owners, engineers, end-users, and product specifiers about labels and listings that relate to critical issues such as product performance and safety. The knowledge gained provides insight on proper material selection and results in reduction of high costs and consequences of corrosion damage. Lunch and Learns are accredited for one Professional Development Hour (PDH).

INSTALLER CERTIFICATION

Proper installation of Perma-Cote products is essential to ensure the best possible service life for a raceway system. Perma-Cote offers installer certification training with classroom and hands-on instruction:

- Proper installation techniques and tools
- Clamping, cutting, threading, bending, and assembly of PVC-coated conduit
- System assembly and best practices
- Techniques and troubleshooting

Only installers who are able to present valid, unexpired credentials of having passed required instruction and examination are officially certified to install Perma-Cote's products.

There is no charge for installer certification. To learn more about this certification program, contact Perma-Cote at (903) 843-4388.

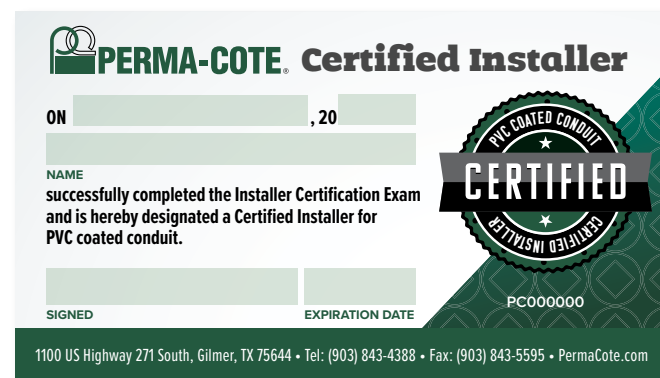

PVC-Coated Conduit

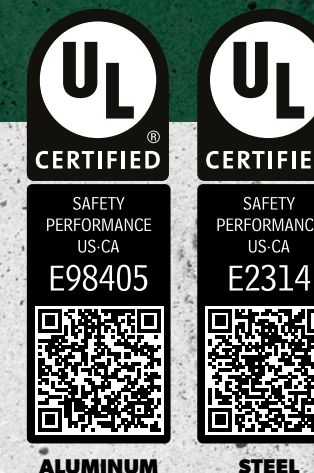

DESCRIPTION

PVC-coated galvanized rigid conduit with green urethane interior coating protects conductors from mechanical damage and corrosive attack. Electrical continuity is maintained across assembled joints.

FEATURES

- 40 mil gray PVC exterior coating
- 2 mil green urethane interior coating
- PROTECH threads – A clear urethane coating over hot galvanized threads
- 12 trade sizes from 1/2" through 6"
- Shipped in 10' lengths with coupling. One "no-charge" coupling is included with each 10' length of conduit
- Plastic thread protector caps are color coded for quick identification of conduit size

STANDARDS

Steel

- ETL PVC-001
- UL 6 (E2314)
- CSA C22.2 No. 45
- ANSI C80.1

Aluminum

- UL 6A (E98405)
- CSA C22.2 No. 45.2
- ANSI C80.5

**Both PVC and zinc coatings have been investigated as primary protection against corrosion. Restricted for use with threaded fittings only.*



INSTALLATION TIP!

Use the spin-it or z-wrench to tighten conduit to protect the coating.

METRIC SIZE DESIGNATORS	PIPE SIZE INCHES	CATALOG #	OUTSIDE WALL THICKNESS INCHES	DIAMETER WITH COATING INCHES	INTERNAL INSIDE DIAMETER INCHES	TRAVERSE AREA SQ. INCHES	NOMINAL WEIGHT	ALUMINUM CATALOG #
16	1/2"	PM050-CON	.104"	.920"	0.632"	0.314"	85.0	PM050-CON-A
21	3/4"	PM075-CON	.107"	1.130"	0.836"	0.549"	112.0	PM075-CON-A
27	1"	PM100-CON	.126"	1.395"	1.063"	0.887"	164.0	PM100-CON-A
35	1-1/4"	PM125-CON	.133"	1.740"	1.394"	1.526"	217.0	PM125-CON-A
41	1-1/2"	PM150-CON	.138"	1.980"	1.624"	2.071"	268.0	PM150-CON-A
53	2"	PM200-CON	.146"	2.455"	2.083"	3.408"	358.0	PM200-CON-A
63	2-1/2"	PM250-CON	.193"	2.955"	2.489"	4.866"	546.0	PM250-CON-A
78	3"	PM300-CON	.205"	3.580"	3.090"	7.499"	708.0	PM300-CON-A
91	3-1/2"	PM350-CON	.215"	4.080"	3.570"	10.010"	851.0	PM350-CON-A
103	4"	PM400-CON	.225"	4.580"	4.050"	12.882"	1009.0	PM400-CON-A
129	5"	PM500-CON	.245"	5.643"	5.073"	20.212"	1337.0	PM500-CON-A
155	6"	PM600-CON	.266"	6.705"	6.093"	29.158"	1993.0	PM600-CON-A

Nipples



DESCRIPTION

Perma-Cote factory-threaded nipples save you time and money in the field. Electrical continuity is maintained across assembled joints.

**The exterior of certain short nipples are coated with urethane in lieu of PVC. This is dictated by the manufacturing process as well as assembly considerations.*

FEATURES

- 40 mil gray PVC exterior coating
- 2 mil green urethane interior coating
- 12 trade sizes from 1/2" through 6"
- 11 standard lengths available: Close, from 2" through 12"
- Made-to-order lengths available in 1/2" increments.
Call for quote
- Plastic thread protector caps are color coded for quick identification of size

Does your installation require custom-length nipples?
Call for a quote at (903) 843-4388 or email your request to CSR@Robroy.com.

STANDARDS

Steel and Aluminum

- UL 6 (E2314); UL 6A (E98405)
- CSA C22.2 No. 45
- Both PVC and zinc coatings have been investigated as primary protection against corrosion. Restricted for use with threaded fittings only

SIMPLE STEPS TO ORDERING

To order the Perma-Cote coated nipples, follow this simple formula to create your Perma-Cote catalog number. Use the Conversion Chart to convert trade sizes to trade code.

PMNIP - CODE X LENGTH -A

The catalog number for a Perma-Cote coated steel, 1/2" nipple with a length of 10": **PMNIP - 050 X 10**

TRY IT!

Enter "NIP" Standard Nipple Prefix Enter Trade Size Code Enter Desired Nipple Length For Aluminum Add '-A' Suffix

PMNIP - [] x [] - A

This number can then be looked up in the price list to determine price and availability.

CONVERSION CHART

TRADE SIZE	TRADE SIZE CODE
1/2"	050
3/4"	075
1"	100
1-1/4"	125
1-1/2"	150
2"	200
2-1/2"	250
3"	300
3-1/2"	350
4"	400
5"	500
6"	600

STEEL NIPPLES

STEEL NIPPLE SIZE	NIPPLE LENGTH							
	CL	1-1/2"	2"	2-1/2"	3"	3-1/2"	4"	5"
1/2"	Yellow	Yellow	Yellow	Yellow	Blue	Blue	Blue	Blue
3/4"	Yellow	Yellow	Yellow	Yellow	Blue	Blue	Blue	Blue
1"	Yellow	Grey	Yellow	Yellow	Blue	Blue	Blue	Blue
1-1/4"	Yellow	Grey	Yellow	Yellow	Blue	Blue	Blue	Blue
1-1/2"	Yellow	Grey	Yellow	Yellow	Blue	Blue	Blue	Blue
2"	Yellow	Grey	Grey	Yellow	Blue	Yellow	Blue	Blue
2-1/2"	Yellow	Grey	Grey	Grey	Blue	Yellow	Blue	Blue
3"	Yellow	Grey	Grey	Grey	Blue	Yellow	Blue	Blue
3-1/2"	Yellow	Grey	Grey	Grey	Blue	Grey	Yellow	Blue
4"	Yellow	Grey	Grey	Grey	Blue	Grey	Grey	Yellow
5"	Yellow	Grey	Grey	Grey	Blue	Grey	Grey	Yellow
6"	Yellow	Grey	Grey	Grey	Blue	Grey	Grey	Yellow

Yellow: Urethane on Interior and Exterior Blue: Urethane on Interior and Threads, PVC Exterior Grey: Invalid Size

ALUMINUM NIPPLES

ALUMINUM NIPPLE SIZE	NIPPLE LENGTH							
	CL	1-1/2"	2"	2-1/2"	3"	3-1/2"	4"	5"
1/2"	Yellow	Yellow	Yellow	Yellow	Blue	Blue	Blue	Blue
3/4"	Yellow	Yellow	Yellow	Yellow	Blue	Blue	Blue	Blue
1"	Yellow	Grey	Yellow	Yellow	Blue	Blue	Blue	Blue
1-1/4"	Yellow	Grey	Yellow	Yellow	Blue	Blue	Blue	Blue
1-1/2"	Yellow	Grey	Yellow	Yellow	Blue	Blue	Blue	Blue
2"	Yellow	Grey	Grey	Yellow	Blue	Yellow	Blue	Blue
2-1/2"	Yellow	Grey	Grey	Grey	Blue	Yellow	Blue	Blue
3"	Yellow	Grey	Grey	Grey	Blue	Yellow	Blue	Blue
3-1/2"	Yellow	Grey	Grey	Grey	Blue	Grey	Yellow	Blue
4"	Yellow	Grey	Grey	Grey	Blue	Grey	Grey	Yellow
5"	Yellow	Grey	Grey	Grey	Blue	Grey	Grey	Yellow
6"	Yellow	Grey	Grey	Grey	Blue	Grey	Grey	Yellow

Yellow: Urethane on Interior and Exterior Blue: Urethane on Interior and Threads, PVC Exterior Grey: Invalid Size

PVC-Coated Elbows



ALUMINUM

STEEL

DESCRIPTION

Perma-Cote factory-bent standard radius elbows are available and ready to ship. Factory-bent elbows are more accurate, quicker to install, and more economical because they save field bending time and do not waste materials. Electrical continuity is maintained across assembled joints.

FEATURES

- 40 mil gray PVC exterior coating
- 2 mil green urethane interior coating
- 12 trade sizes from 1/2" through 6"
- Available in standard sizes 90°, 60°, 45°, 30°, and 22 1/2° bends
- Plastic thread protector caps are color coded for quick identification of conduit size

STANDARDS

Steel and Aluminum

- UL 6 (E2314); UL 6A (E98405)
- CSA C22.2 No. 45
- Both PVC and zinc coatings have been investigated as primary protection against corrosion. Restricted for use with threaded fittings only



INSTALLATION TIP!

If transitioning from Schedule 40 or 80 PVC use a sealing locknut to project your elbow threads.

SIMPLE STEPS TO ORDERING

To order the Perma-Cote coated elbows, follow this simple formula to create your Perma-Cote catalog number. Use the Conversion Chart to convert trade sizes to trade code.

The catalog number for a Perma-Cote coated steel, 1/2" elbow with a 45° bend: **PMEL - 050 X 45**

TRY IT!

REQUIRED

Enter "EL" Standard Elbow Prefix

Enter Trade Size Code

Enter the Degree of Bend

OPTIONAL

For Large Radius Elbows Enter Radius

For Aluminum Add 'A' Suffix

PMEL - X X - A

This number can then be looked up in the price list to determine price and availability.

CONVERSION CHART

TRADE SIZE	TRADE SIZE CODE
1/2"	050
3/4"	075
1"	100
1-1/4"	125
1-1/2"	150
2"	200
2-1/2"	250
3"	300
3-1/2"	350
4"	400
5"	500
6"	600

- A = Radius at inside of bend
- B = Radius at center line of bend
- C = Radius at outside of bend
- D = Offset at inside of bend
- E = Offset at center of bend
- F = Offset at outside of bend

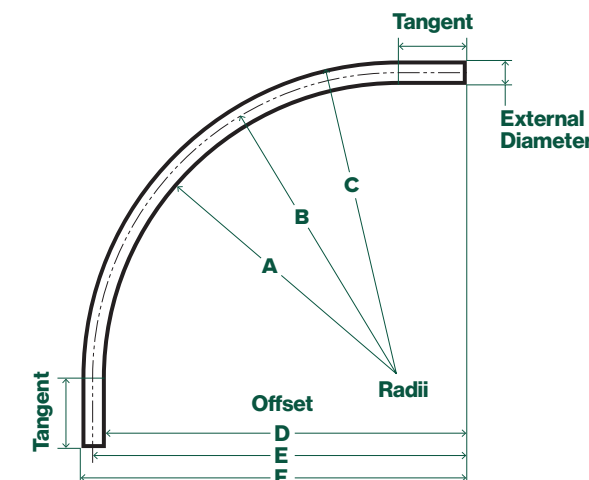

STANDARD RADIUS ELBOWS

METRIC SIZE DESIGNATORS	NOMINAL SIZE INCHES	DIAMETERS		NIPPLE LENGTHS INCHES	RADI			OFFSET			TANGENT INCHES
		EXTERNAL INCHES	INTERNAL INCHES		A INCHES	(STANDARD) B INCHES	C INCHES	D INCHES	E INCHES	F INCHES	
16	1/2"	0.920"	0.632"	11-1/4"	3.79"	4.25"	4.71"	6.040"	6.500"	6.960"	2.250"
21	3/4"	1.130"	0.836"	12-1/2"	3.94"	4.50"	5.07"	6.685"	7.250"	7.815"	2.750"
27	1"	1.395"	1.063"	14-3/4"	5.05"	5.75"	6.45"	7.928"	8.625"	9.323"	2.875"
35	1-1/4"	1.740"	1.394"	17-3/4"	6.38"	7.25"	8.12"	9.567"	10.437"	11.307"	3.187"
41	1-1/2"	1.980"	1.624"	19-3/4"	7.26"	8.25"	9.24"	10.635"	11.625"	12.615"	3.375"
53	2"	2.455"	2.083"	22-1/2"	8.27"	9.50"	10.73"	12.086"	13.313"	14.541"	3.813"
63	2-1/2"	2.955"	2.489"	28"	9.02"	10.50"	11.98"	14.776"	16.253"	17.731"	5.753"
78	3"	3.580"	3.080"	32"	11.21"	13.00"	14.79"	17.000"	18.790"	20.580"	5.790"
91	3-1/2"	4.080"	3.570"	39-1/2"	12.96"	15.00"	17.04"	20.920"	22.960"	25.000"	7.960"
103	4"	4.580"	4.050"	39-1/2"	13.71"	16.00"	18.29"	20.890"	23.180"	25.470"	7.180"
129	5"	5.643"	5.073"	59-1/2"	21.18"	24.00"	26.82"	32.079"	34.900"	37.722"	10.900"
155	6"	6.705"	6.093"	76"	26.65"	30.00"	33.35"	41.088"	44.440"	47.793"	14.440"

SPECIAL RADIUS ELBOWS

B - RADIUS IN INCHES	12"	15"	18"	18"	24"	24"	30"	30"	36"	36"	36"	42"	42"	48"	48"	48"
E - OFFSET	1'5-1/2"	1'9-1/4"	2'1/4"	2'3"	2'8"	2'10"	3'4"	3'5"	3'11"	3'11-1/4"	4'3-1/4"	4'5"	4'6"	5'1/4"	5'1-1/4"	5'3-1/4"
NIPPLE LENGTH	2'6"	3'0"	3'5"	3'10"	4'6"	4'9"	5'6"	5'9"	6'7"	6'7"	7'3"	7'4"	7'6"	8'4"	8'6"	8'10"
TANGENT	5-1/2"	6-1/4"	6-1/4"	9"	8"	10"	10"	11"	11"	11-1/4"	15-1/4"	11"	12"	12-1/4"	13-1/4"	15-1/4"
AVAILABLE PIPE SIZES	1" & 2"	2"	1"	1-1/2" to 3"	3/4" to 2"	2-1/2" to 5"	2" to 3"	4" to 5"	3/4" to 4"	5"	6"	4"	5"	1-1/2" to 4"	5"	6"

Perma-Cote factory-bent elbows are also available in larger than standard radii to accommodate your special needs. Simply follow the four steps for standard radius elbows on the previous page, then continue with Steps 5 and 6 for large radius elbows. Refer to the table below to determine which radius is available for the size of conduit you need.

To use the Long or Special Radius Elbow table, find the elbow radius required in the first row. Then look down the column to determine which conduit sizes are available in that radius. Use this information in Steps 5 and 6 on the previous page to build a catalog number.

PVC-Coated Couplings



DESCRIPTION

PVC-coated couplings with green urethane interior connect conduit sections. Electrical continuity is maintained across assembled joints. PVC sleeves overlap conduit, preventing corrosive liquids and vapors from attacking threaded joints.

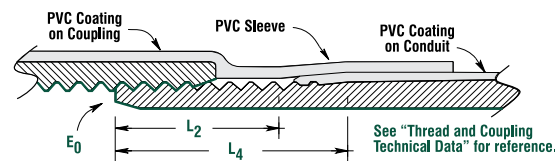

All female pipe openings are provided with a PVC sleeve sized to fit tightly over the PVC-coated conduit when assembled. This prevents corrosion from attacking threaded joints, and are not to be removed.

COUPLING					THREADS				ALUMINUM CATALOG #
METRIC SIZE DESIGNATORS	PIPE SIZE INCHES	STEEL CATALOG #	NOMINAL WEIGHT PER 100 (POUNDS)	OUTSIDE DIAMETER WITH RIBS INCHES	THREADS PER INCH	EFFECTIVE LENGTH L2	TOTAL LENGTH OF THREADS TO VANISH POINT L4	PITCH AT END OF THREAD 3/4 IN. TAPER E0	
16	1/2"	PM CPL-050	19	1.344"	14	.5337"	.7815"	.7584"	PM CPL-050-A
21	3/4"	PM CPL-075	32	1.531"	14	.5457"	.7935"	.9677"	PM CPL-075-A
27	1"	PM CPL-100	40	1.781"	11-1/2	.6828"	.9845"	1.2156"	PM CPL-100-A
35	1-1/4"	PM CPL-125	50	2.156"	11-1/2	.7068"	1.0085"	1.5571"	PM CPL-125-A
41	1-1/2"	PM CPL-150	69	2.469"	11-1/2	.7235"	1.0252"	1.7961"	PM CPL-150-A
53	2"	PM CPL-200	93	2.969"	11-1/2	.7565"	1.0582"	2.2690"	PM CPL-200-A
63	2-1/2"	PM CPL-250	123	3.594"	8	1.1375"	1.5712"	2.7195"	PM CPL-250-A
78	3"	PM CPL-300	217	4.250"	8	1.2000"	1.6337"	3.3406"	PM CPL-300-A
91	3-1/2"	PM CPL-350	422	4.875"	8	1.2500"	1.6837"	3.8375"	PM CPL-350-A
103	4"	PM CPL-400	391	5.250"	8	1.3000"	1.7337"	4.3344"	PM CPL-400-A
129	5"	PM CPL-500	550	6.080"	8	1.4063"	1.8400"	5.3907"	PM CPL-500-A
155	6"	PM CPL-600	884	7.280"	8	1.5125"	1.9462"	6.4461"	PM CPL-600-A

FEATURES

- 40 mil gray PVC exterior coating
- 2 mil green urethane interior coating over galvanized threads
- 12 trade sizes from 1/2" through 6"
- Sealing sleeves on both ends
- Molded external ribs on 1/2" through 4" for ease of installation
- Couplings are straight tapped

STANDARDS

Steel and Aluminum

- UL 6 (E2314); UL 6A (E98405)
- CSA C22.2 No. 45



PVC-Coated SpeedCouple



DESCRIPTION

PVC-Coated SpeedCouple is used to quickly and easily install PVC-coated rigid conduit and elbows. Rated for direct burial and ideal for tight space applications, PVC-Coated SpeedCouple allows you to complete connections without having to turn the conduit or elbows.

FEATURES

- Trade sizes 2" through 6"
- 40 mil gray PVC exterior coating, urethane interior coating
- Sealing Sleeves on both ends
- Stainless Steel Locking Screw
- Lead-in threads facilitate threading & ground continuity
- Concrete tight
- Suitable for direct burial
- NPT Threads

ORDERING INFORMATION

CATALOG NUMBER	DESCRIPTION	WEIGHT PER 100 (LBS)	STANDARD PACK QUANTITY	UPC	AVAIL. CODE
PMSCPLG-2	2" PVC-COATED SPEEDCOUPLE	88	30	784011923090	1
PMSCPLG-2-1/2	2-1/2" PVC-COATED SPEEDCOUPLE	176	9	784011923106	1
PMSCPLG-3	3" PVC-COATED SPEEDCOUPLE	198	8	784011923113	1
PMSCPLG-3-1/2	3-1/2" PVC-COATED SPEEDCOUPLE	265	8	784011923120	1
PMSCPLG-4	4" PVC-COATED SPEEDCOUPLE	309	8	784011923137	1
PMSCPLG-5	5" PVC-COATED SPEEDCOUPLE	397	4	784011923144	1
PMSCPLG-6	6" PVC-COATED SPEEDCOUPLE	525	2	784011923151	1

STANDARDS

- UL 514B (E200413)
- CSA C22.2 No. 18.3-12

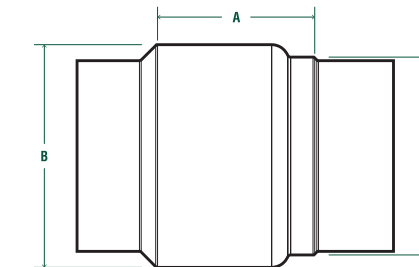

DIMENSIONS

COUPLING SIZE	A	B	C
2"	2.459	2.955	2.64
2-1/2"	3.425	3.58	3.131
3"	3.545	4.19	3.748
3-1/2"	3.665	4.83	4.25
4"	3.761	5.33	4.755
5"	4.065	6.355	5.86
6"	4.065	7.463	6.91



INSTALLATION TIP!

In a tight space and having a hard time turning conduit or elbows? This installation method only requires you to spin the speed couple instead. Make sure you have a strap wrench and hex wrench on hand.





DESCRIPTION

The patented PVC-coated sealing locknut properly protects exposed conduit threads at the point of connection, giving you a superior sealed system. Ideal for transitions where product is unable to be coated (for example, when transitioning from coated galvanized rigid conduit to Schedule 40 PVC).

FEATURES

- 40 mil gray PVC exterior coating
- Trade sizes from ½" through 6"
- Built-in gasket at face of locknut
- Integral sleeve on reverse side of locknut

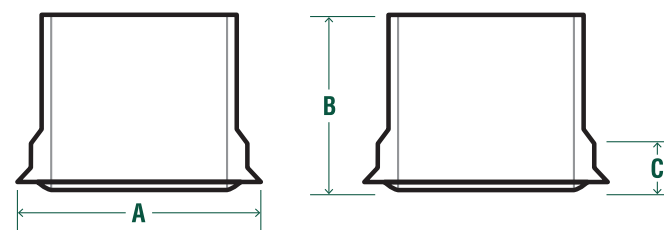

METRIC SIZE DESIGNATORS	PIPE SIZE (INCHES)	CATALOG #	A	B	C	NOMINAL WEIGHT
16	1/2"	PMSIB101	1.375	1.250	0.250	0.03
21	3/4"	PMSIB102	1.625	1.250	0.250	0.04
27	1"	PMSIB103	1.940	1.250	0.250	0.06
35	1-1/4"	PMSIB104	2.375	1.250	0.250	0.08
41	1-1/2"	PMSIB105	2.625	1.563	0.313	0.11
53	2"	PMSIB106	3.125	1.563	0.313	0.14
63	2-1/2"	PMSIB107	3.750	1.813	0.313	0.18
78	3"	PMSIB108	4.500	1.875	0.375	0.22
91	3-1/2"	PMSIB109	5.000	2.250	0.375	0.30
103	4"	PMSIB110	5.500	2.250	0.375	0.38
129	5"	PMSIB111	6.000	2.375	0.500	0.54
155	6"	PMSIB112	6.500	2.375	0.500	0.70

DESCRIPTION

Perma-Cote device boxes and covers are available in several configurations and may be used in coated conduit systems to accommodate wiring devices, to serve as pull boxes for conductors, or to allow for splices and taps in conductors. Covers are available separately. Electrical continuity of the conduit system is maintained across assembled joints.

FEATURES

- 40 mil gray PVC exterior coating
- 2 mil green urethane interior coating
- 3 trade sizes from ½" through 1"
- Available in Standard (FS) and Deep (FD) styles
- Internal grounding screw is standard
- Sealing sleeves on all female conduit openings

STANDARDS

Steel and Aluminum

- UL 514A, 514D (E231035)
- CSA C22.2 No. 18, CSA C22.2 No. 42

Cast Device Boxes – Single Gang

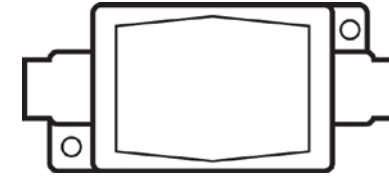
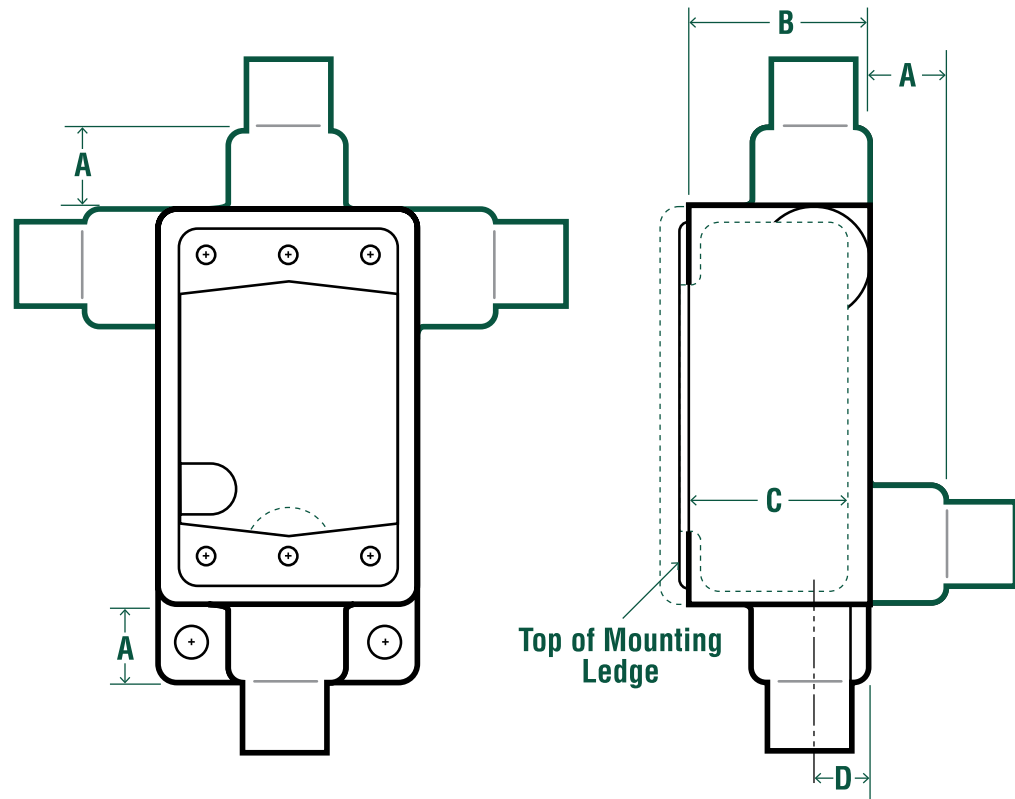

FSC SERIES (SHALLOW BOX) - SINGLE GANG THROUGH FEED

PIPE SIZE	FERROUS CATALOG #	NOMINAL WEIGHT	A	B	C	D	ALUMINUM CATALOG #
1/2"	PMFSC-150	2.2	0.88	1.92	1.69	0.67	PMFSC-150-A*
3/4"	PMFSC-175	2.4	0.88	1.92	1.69	0.79	PMFSC-175-A*
1"	PMFSC-100	2.7	1.00	1.92	1.69	0.92	PMFSC-100-A*

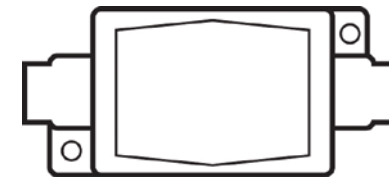

FDC SERIES (DEEP BOX) - SINGLE GANG THROUGH FEED

PIPE SIZE	FERROUS CATALOG #	NOMINAL WEIGHT	A	B	C	D	ALUMINUM CATALOG #
1/2"	PMFDC-150	2.7	0.88	2.69	2.50	0.67	PMFDC-150-A*
3/4"	PMFDC-175	2.8	0.88	2.69	2.50	0.79	PMFDC-175-A*
1"	PMFDC-100	3.1	1.00	2.69	2.50	0.92	PMFDC-100-A*

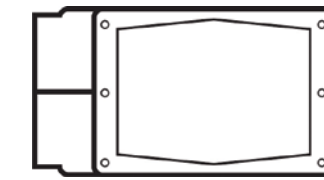

FSS SERIES

PIPE SIZE	FERROUS CATALOG #	NOMINAL WEIGHT	A	B	C	D	ALUMINUM CATALOG #
1/2"	PMFSS1	3.2	0.88	1.92	1.69	0.67	PMFSS1-A*
3/4"	PMFSS2	3.3	0.88	1.92	1.69	0.79	PMFSS2-A*
1"	PMFSS3	3.5	1.00	1.92	1.69	0.92	-

All configurations offered in both 'FS' or 'FD' box depths. FS prefix: Shallow configuration, FD prefix: Deep configuration.

* Available in copper-free aluminum.

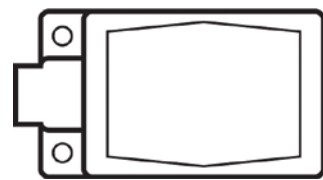

FS SERIES (SHALLOW BOX) - SINGLE GANG DEAD END

PIPE SIZE	FERROUS CATALOG #	NOMINAL WEIGHT	A	B	C	D	ALUMINUM CATALOG #
1/2"	PMFS-150	3.2	0.88	1.92	1.69	0.67	PMFS-150-A*
3/4"	PMFS-175	3.3	0.88	1.92	1.69	0.79	PMFS-175-A*
1"	PMFS-100	3.5	1.00	1.92	1.69	0.92	PMFS-100-A*

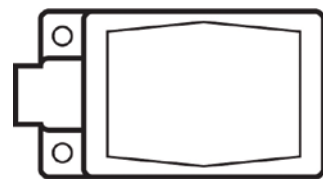

FD SERIES (DEEP BOX) - SINGLE GANG DEAD END

PIPE SIZE	FERROUS CATALOG #	NOMINAL WEIGHT	A	B	C	D	ALUMINUM CATALOG #
1/2"	PMFD-150	2.7	0.88	2.69	2.50	0.67	PMFD-150-A*
3/4"	PMFD-175	2.8	0.88	2.69	2.50	0.79	PMFD-175-A*
1"	PMFD-100	3.1	1.00	2.69	2.50	0.92	PMFD-100-A*

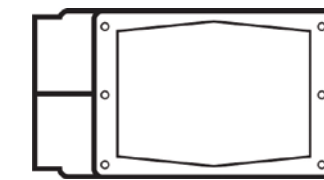

FDD SERIES

PIPE SIZE	FERROUS CATALOG #	NOMINAL WEIGHT	A	B	C	D	ALUMINUM CATALOG #
1/2"	PMFDD-150	2.7	0.88	2.69	2.50	0.67	-
3/4"	PMFDD-175	2.8	0.88	2.69	2.50	0.79	PMFDD-175-A*
1"	PMFDD-100	3.1	1.00	2.69	2.50	0.92	-

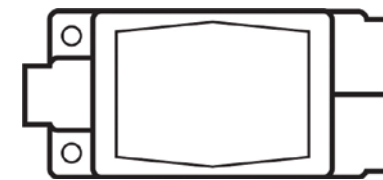

FSCC SERIES

PIPE SIZE	FERROUS CATALOG #	NOMINAL WEIGHT	A	B	C	D
1/2"	PMFSCC-150	2.0	0.88	1.92	1.69	0.67
3/4"	PMFSCC-175	2.2	0.88	1.92	1.69	0.79

Cast Device Boxes – Single Gang

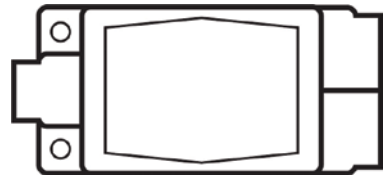

FDCC SERIES

PIPE SIZE	FERROUS CATALOG #	NOMINAL WEIGHT	A	B	C	D
1/2"	PMFDCC-1-50	2.7	0.88	2.69	2.50	0.67
3/4"	PMFDCC-1-75	2.8	0.88	2.69	2.50	0.79

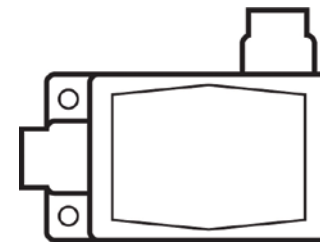

FSR SERIES

PIPE SIZE	FERROUS CATALOG #	NOMINAL WEIGHT	A	B	C	D
1/2"	PMFSR-1-50	2.0	0.88	1.92	1.69	0.67
3/4"	PMFSR-1-75	2.2	0.88	1.92	1.69	0.79

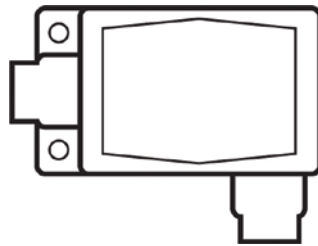

FDL SERIES

PIPE SIZE	FERROUS CATALOG #	NOMINAL WEIGHT	A	B	C	D
1/2"	PMFDL-1-50	3.1	0.88	2.69	2.50	0.67
3/4"	PMFDL-1-75	3.3	0.88	2.69	2.50	0.79

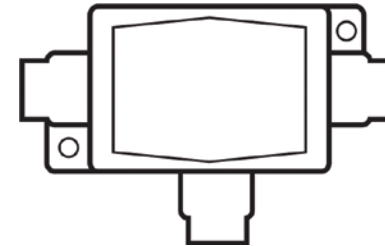

FDCT SERIES

PIPE SIZE	FERROUS CATALOG #	NOMINAL WEIGHT	A	B	C	D
1/2"	PMFDCTI-50	3.1	0.88	2.69	2.50	0.67
3/4"	PMFDCTI-75	3.4	0.88	2.69	2.50	0.79
1"	PMFDCTI-100	3.9	1.00	2.69	2.50	0.92

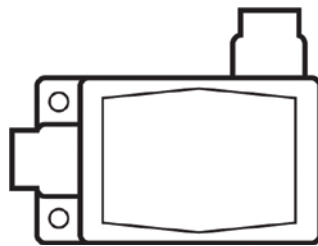

FDR SERIES

PIPE SIZE	FERROUS CATALOG #	NOMINAL WEIGHT	A	B	C	D
1/2"	PMFDR-1-50	3.2	0.88	2.69	2.50	0.67
3/4"	PMFDR-1-75	3.3	0.88	2.69	2.50	0.79

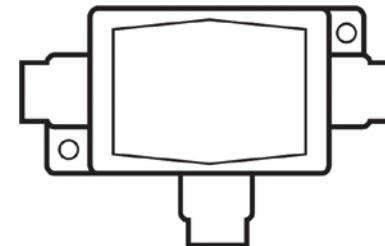

FSCT SERIES

PIPE SIZE	FERROUS CATALOG #	NOMINAL WEIGHT	A	B	C	D
1/2"	PMFSCTI-50	2.2	0.88	1.92	1.69	0.67
3/4"	PMFSCTI-75	2.5	0.88	1.92	1.69	0.79
1"	PMFSCTI-100	2.8	1.00	1.92	1.69	0.92

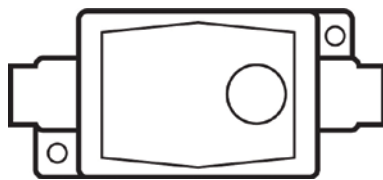

FSCA SERIES

PIPE SIZE	FERROUS CATALOG #	NOMINAL WEIGHT	A	B	C	D
1/2"	PMFSCA-1-50	2.5	0.88	1.92	1.69	0.67
3/4"	PMFSCA-1-75	3.5	0.88	1.92	1.69	0.79

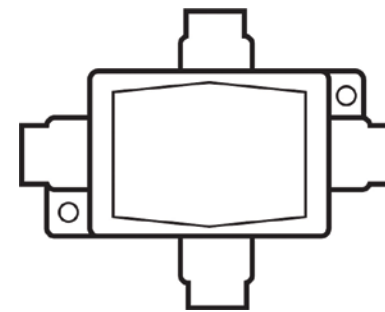

FSX SERIES

PIPE SIZE	FERROUS CATALOG #	NOMINAL WEIGHT	A	B	C	D
1/2"	PMFSX1	2.5	0.88	1.92	1.69	0.67
3/4"	PMFSX2	2.7	0.88	1.92	1.69	0.79

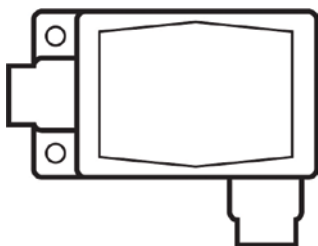

FSL SERIES

PIPE SIZE	FERROUS CATALOG #	NOMINAL WEIGHT	A	B	C	D
1/2"	PMFSL-1-50	2.5	0.88	1.92	1.69	0.67
3/4"	PMFSL-1-75	2.7	0.88	1.92	1.69	0.79

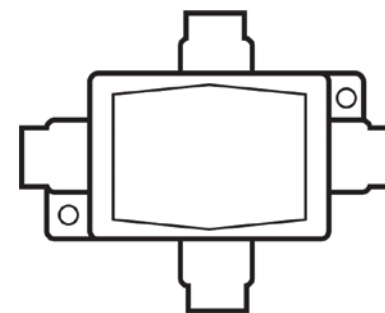

FDX SERIES

PIPE SIZE	FERROUS CATALOG #	NOMINAL WEIGHT	A	B	C	D
1/2"	PMFDX1	2.5	0.88	2.69	2.50	0.67
3/4"	PMFDX2	2.7	0.88	2.69	2.50	0.79
1"	PMFDX3	2.5	1.00	2.69	2.50	0.92

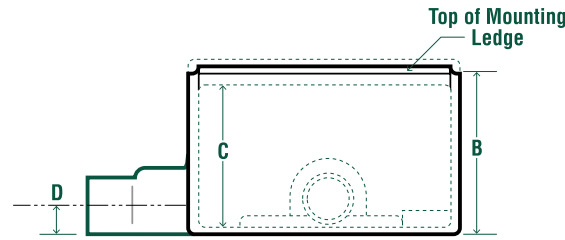
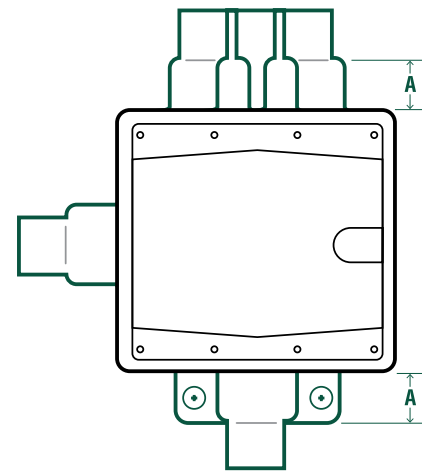

All configurations offered in both 'FS' or 'FD' box depths. FS prefix: Shallow configuration, FD prefix: Deep configuration.

* Available in copper-free aluminum.

FS/FD SINGLE GANG COVER CONFIGURATIONS



PMDS100



PMDS100G

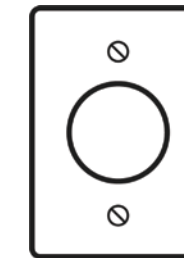

PMDS21



PMDS21G

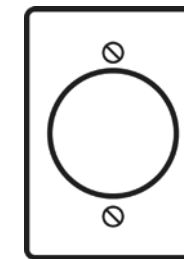

PMDS35



PMDS32G

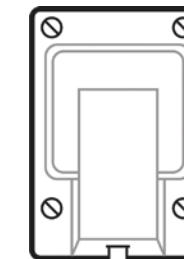

PMDS128

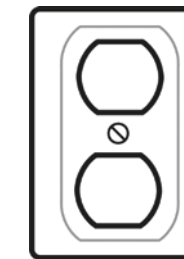

PMDS23



PMDS23G

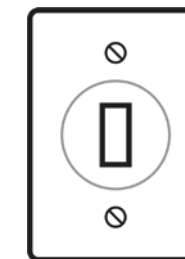

PMDS32

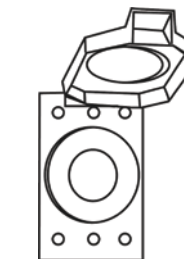

PMWLR1

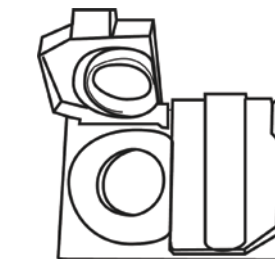

PMWLRD1

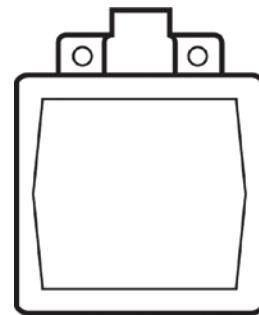

FS SERIES

(SHALLOW BOX) - TWO GANG DEAD END

PIPE SIZE	FERROUS CATALOG #	NOMINAL WEIGHT	A	B	C	D	ALUMINUM CATALOG #
1/2"	PMFS-2-50	3.3	0.88	1.92	1.69	0.67	PMFS-2-50-A*
3/4"	PMFS-2-75	3.4	0.88	1.92	1.69	0.79	PMFS-2-75-A*
1"	PMFS-2-100	3.6	1.00	1.92	1.69	0.92	-

FD SERIES

(DEEP BOX) - TWO GANG

PIPE SIZE	FERROUS CATALOG #	NOMINAL WEIGHT	A	B	C	D	ALUMINUM CATALOG #
1/2"	PMFD12	3.3	0.88	2.69	2.50	0.67	-
3/4"	PMFD22	3.3	0.88	2.69	2.50	0.79	PMFD22-A*
1"	PMFD32	3.6	1.00	2.69	2.50	0.92	-

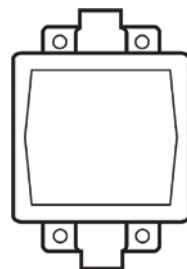

FSC SERIES

(SHALLOW BOX) - TWO GANG THROUGH FEED

PIPE SIZE	FERROUS CATALOG #	NOMINAL WEIGHT	A	B	C	D
1/2"	PMFSC-2-50	3.3	0.88	1.92	1.69	0.67
3/4"	PMFSC-2-75	3.6	0.88	1.92	1.69	0.79
1"	PMFSC-2-100	4.0	1.00	1.92	1.69	0.92

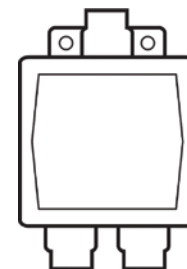

FSD SERIES

(DEEP BOX) - TWO GANG THROUGH FEED

PIPE SIZE	CATALOG #	NOMINAL WEIGHT	A	B	C	D
3/4"	PMFSD-2-75	2.5	0.88	2.69	1.69	0.79

* Bottom hubs are 1/2".

FERROUS COVERS - ONE GANG

CATALOG #	DESCRIPTION	NOMINAL WEIGHT
PMDS32	General Use Snap On Or Toggle (S)	0.4
PMDS23G	Duplex Convenience Receptacle (S,F)	0.4
PMDS35	Plug Receptacle 1-5/8" Diameter (S)	0.4
PMDS21	3P 2W Grounding Round Flush Receptacles (S)	0.3
PMDS21G	3P 2W Grounding Round Flush Receptacles (S,F)	0.3
PMDS23	Duplex Convenience Receptacle (S)	0.3
PMDS32G	Square Handle Snap Or Toggle (S,F)	0.4

S - Surface F - Flush

ALUMINUM COVERS - ONE GANG

CATALOG #	DESCRIPTION	NOMINAL WEIGHT
PMDS23SA	Duplex Convenience Receptacle (S)	0.1
PMDS100	Blank Cover (S)	0.1
PMDS128	Snap Switch	0.5
PMDS100G	Blank Cover Cast (S,F)	0.3
PMWLRD1	Spring Door Duplex Cover 1-3/8" (F)	0.4
PMWLR1	Spring Door Single Cover 1-3/8" (F)	0.3
PMWLR2	Spring Door Single Cover 1-1/2" (F)	0.3
PMWLGF-FS	Spring Door Cover For GFCI (S) - Horizontal	0.5
PMWLGF-FSV	Spring Door Cover For GFCI (S) - Vertical	0.5
PMWLGF	Spring Door Cover For GFCI (F) - Horizontal	0.5

FS/FD 2 GANG COVER CONFIGURATIONS

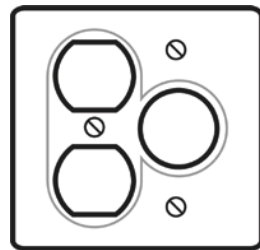

PMS21232

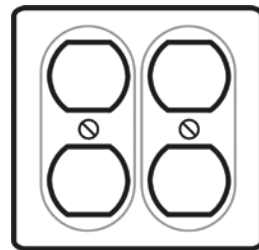

PMS232

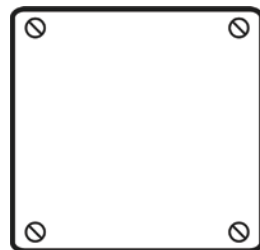

PMS1002

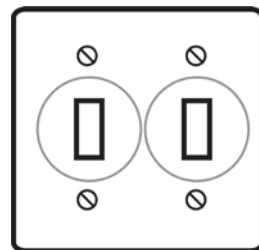

PMS322

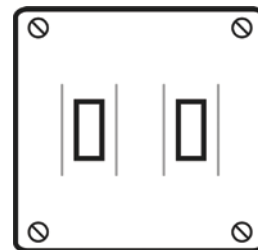

PMS322G

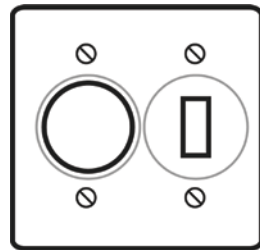

PMS32212

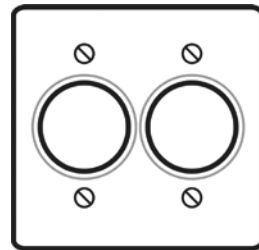

PMS212

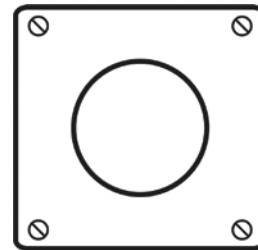

PMS612

FERROUS COVERS - TWO GANG

CATALOG #	DESCRIPTION	NOMINAL WEIGHT
PMS1002	Blank Cover Sheet Steel (S)	1.0
PMS1002G	Blank Cover Iron Alloy (S,F)	1.0
PMS21232	Round Receptacle + Duplex Convenience	1.2
PMS232	Duplex Convenience (S)	1.2
PMS322	Snap Switch (S)	1.0
PMS32212	Round Receptacle + Snap Switch (S)	1.2
PMS212	Two Round Receptacles (S)	2.0
PMS612	20 Amp, 250 Vold Receptacle (S)	1.2
PMS322G	Snap Switches Iron Alloy (S,F)	1.2

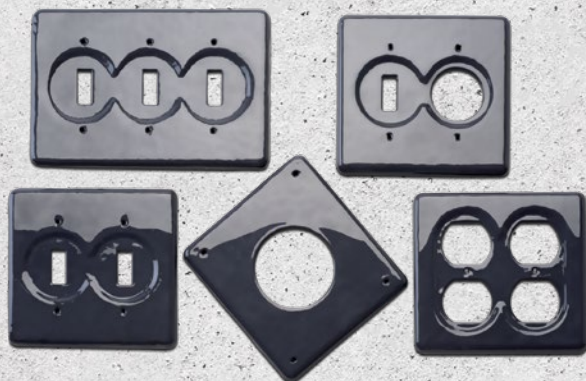

DESCRIPTION

Perma-Cote conduit bodies with covers are offered in Form 7, Form 8, and Mark 9 styles, each with numerous configurations to provide a complete coated conduit system. May be used to make 90° bends, for pull outlets, to provide for taps or splices, to act as a mounting outlet for wiring devices or lighting fixtures, etc. Form 8 and Mark 9 style fittings from ½” through 4” have an integral V-Seal gasket for superior corrosion protection. Electrical continuity of the conduit system is maintained across assembled joints.

FEATURES

- 40 mil gray PVC exterior coating
- 2 mil green urethane interior coating
- Sealing sleeves on all female conduit openings
- Form 7 style cover uses retained stainless screw and wedge clip design
- Form 8 style cover uses plastic encapsulated stainless steel screws with retainers built into covers
- Integral V-Seal gasket on Form 8 and Mark 9 style

STANDARDS

Steel and Aluminum

- UL 514A, 514B, 514D (E231035)
- CSA C22.2 No. 18, CSA C22.2 No. 42

Form 8 & Mark 9 Fittings – ½” through 4”

- IEC IP69 (E489286)
- UL Type 4X

NOTE: Form 7 fittings are not available with encapsulated screws. All cover screws are stainless steel.



INSTALLATION TIP!

Never remove sealing sleeves. They provide protection at the joints.

Conduit Bodies and Covers

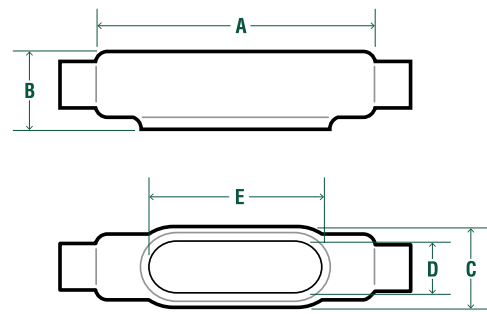

C FORM 7

PIPE SIZE	FERROUS CATALOG #	NOMINAL WEIGHT	A	B	C	D	E	ALUMINUM CATALOG #
1/2"	PMC17	1.0	5.38	1.42	1.46	0.94	3.19	PMC17-A
3/4"	PMC27	1.4	6.00	1.67	1.64	1.13	3.81	PMC27-A
1"	PMC37	2.2	7.00	1.92	1.83	1.38	4.50	PMC37-A
1-1/4"	PMC47	2.7	7.44	2.35	2.27	1.75	5.00	PMC47-A
1-1/2"	PMC57	4.0	8.19	2.60	2.52	1.94	5.44	PMC57-A
2"	PMC67	5.5	9.19	3.17	3.08	2.44	6.38	PMC67-A
2-1/2"	PMC77	10.0	12.00	3.67	4.33	3.56	8.38	PMC77-A
3"	PMC87	11.8	11.75	4.42	4.33	3.56	8.38	PMC87-A

C FORM 8

PIPE SIZE	FERROUS CATALOG #	NOMINAL WEIGHT	A	B	C	D	E
1/2"	PMC50	2.0	5.69	1.48	1.46	1.00	3.31
3/4"	PMC75	2.3	6.28	1.73	1.27	1.19	3.94
1"	PMCI00	2.8	7.31	1.98	1.83	1.38	4.56
1-1/4"	PMCI25	4.5	8.50	2.42	2.27	1.75	5.31
1-1/2"	PMCI50	6.5	10.38	2.82	2.83	2.13	6.50
2"	PMC200	10.3	12.25	3.60	3.83	3.00	8.56
2-1/2"	PMC250	18.0	15.63	4.48	5.08	4.25	10.88
3"	PMC300	20.5	15.63	4.85	5.08	4.25	10.88

C MARK 9

PIPE SIZE	NOMINAL WEIGHT	A	B	C	D	E	ALUMINUM CATALOG #
1/2"	2.0	5.00	1.42	1.46	1.19	3.31	PMC50-A
3/4"	2.3	5.69	1.67	1.64	1.38	3.94	PMC75-A
1"	2.8	6.59	1.92	1.83	1.50	4.56	PMCI00-A
1-1/4"	4.5	7.50	2.54	2.27	1.94	5.31	PMCI25-A
1-1/2"	6.5	8.25	2.79	2.58	2.25	6.00	PMCI50-A
2"	10.3	10.50	3.48	3.27	2.88	8.06	PMC200-A
2-1/2"	18.0	15.63	4.48	5.08	4.25	10.88	PMC250-A
3"	20.5	15.63	4.85	5.08	4.25	10.88	PMC300-A
3-1/2"	10.0	18.75	5.73	6.33	5.44	13.44	PMC350
4"	12.0	18.75	5.98	6.33	5.44	13.44	PMC400

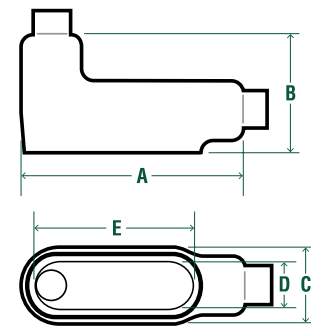

LB FORM 7

PIPE SIZE	FERROUS CATALOG #	NOMINAL WEIGHT	A	B	C	D	E	ALUMINUM CATALOG #
1/2"	PMLB17	1.1	4.60	2.25	1.46	0.94	3.19	PMLB12-A
3/4"	PMLB27	1.7	5.24	2.50	1.64	1.13	3.81	PMLB27-A
1"	PMLB37	2.2	6.04	2.88	1.83	1.38	4.50	PMLB37-A
1-1/4"	PMLB47	3.1	6.54	3.31	2.27	1.75	5.00	PMLB47-A
1-1/2"	PMLB57	3.8	7.17	3.69	2.52	1.94	5.44	PMLB57-A
2"	PMLB67	5.2	8.17	4.25	3.08	2.44	6.38	PMLB67-A
2-1/2"	PMLB777	10.0	10.54	5.13	4.33	3.56	8.38	PMLB777-A
3"	PMLB87	13.0	10.54	5.88	4.33	3.56	8.38	PMLB87-A
3-1/2"	PMLB97	19.0	12.73	6.56	5.33	4.50	10.25	PMLB97-A
4"	PMLB107	18.5	12.73	7.06	5.33	4.50	10.25	PMLB107-A

LB FORM 8

PIPE SIZE	FERROUS CATALOG #	NOMINAL WEIGHT	A	B	C	D	E
1/2"	PMLB50	1.5	4.98	2.22	1.46	1.00	3.31
3/4"	PMLB75	2.0	5.60	2.44	1.64	1.19	3.94
1"	PMLB100	2.9	6.51	2.81	1.83	1.38	4.56
1-1/4"	PMLB125	4.1	7.57	3.34	2.27	1.75	5.31
1-1/2"	PMLB150	6.5	9.17	4.03	2.83	2.13	6.50
2"	PMLB175	8.2	11.04	4.81	3.83	3.00	8.56
2-1/2"	PMLB200	18.2	13.98	6.13	5.08	4.25	10.88
3"	PMLB250	21.2	13.98	6.50	5.08	4.25	10.88
3-1/2"	PMLB300	31.2	16.92	7.56	6.33	5.44	13.44
4"	PMLB400	32.0	16.92	7.81	6.33	5.44	13.44

LB MARK 9

PIPE SIZE	NOMINAL WEIGHT	A	B	C	D	E	ALUMINUM CATALOG #
1/2"	1.5	4.63	2.13	1.46	1.19	3.31	PMLB50-A
3/4"	2.0	5.29	2.41	1.64	1.38	3.94	PMLB75-A
1"	2.9	6.13	2.84	1.83	1.50	4.56	PMLB100-A
1-1/4"	4.1	7.07	3.47	2.27	1.94	5.31	PMLB125-A
1-1/2"	6.5	7.79	3.75	2.58	2.25	6.00	PMLB150-A
2"	8.2	10.07	4.47	3.27	2.88	8.06	PMLB200-A
2-1/2"	18.2	13.98	6.13	5.08	4.25	10.88	PMLB250-A
3"	21.2	13.98	6.50	5.08	4.25	10.88	PMLB300-A
3-1/2"	31.2	16.92	7.56	6.33	5.44	13.44	PMLB350-A
4"	32.0	16.92	7.81	6.33	5.44	13.44	PMLB400-A

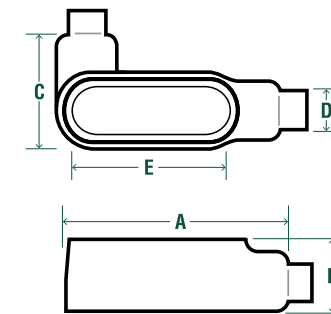

LL FORM 7

PIPE SIZE	FERROUS CATALOG #	NOMINAL WEIGHT	A	B	C	D	E	ALUMINUM CATALOG #
1/2"	PMLL17	1.2	4.60	1.42	2.29	0.94	3.19	PMLL17-A
3/4"	PMLL27	1.6	5.23	1.67	2.48	1.13	3.81	PMLL27-A
1"	PMLL37	2.1	6.04	1.92	2.79	1.38	4.50	PMLL37-A
1-1/4"	PMLL47	3.0	6.54	2.35	3.23	1.75	5.00	PMLL47-A
1-1/2"	PMLL57	4.1	7.17	2.60	3.60	1.94	5.44	PMLL57-A
2"	PMLL67	5.7	8.17	3.17	4.17	2.44	6.38	PMLL67-A
2-1/2"	PMLL77	10.0	10.54	3.67	5.79	3.56	8.38	PMLL77-A
3"	PMLL87	12.7	10.54	4.42	5.79	3.56	8.38	PMLL87-A
3-1/2"	PMLL97	19.0	12.73	4.92	6.98	4.50	10.25	PMLL97-A
4"	PMLL107	19.0	12.73	5.42	6.98	4.50	10.25	PMLL107-A

LL MARK 9

PIPE SIZE	NOMINAL WEIGHT	A	B	C	D	E	ALUMINUM CATALOG #
1/2"	1.4	4.63	1.42	2.17	1.19	3.31	PMLL50-A
3/4"	2.1	5.29	1.67	2.42	1.38	3.94	PMLL75-A
1"	2.6	6.13	1.92	2.67	1.50	4.56	PMLL100-A
1-1/4"	4.2	7.07	2.54	3.13	1.94	5.31	PMLL125-A
1-1/2"	6.2	7.79	2.79	3.48	2.25	6.00	PMLL150-A
2"	10.5	10.07	3.48	4.17	2.88	8.06	PMLL200-A
2-1/2"	19.0	13.98	4.48	6.73	4.25	10.88	PMLL250-A
3"	21.5	13.98	4.85	6.73	4.25	10.88	PMLL300-A
3-1/2"	21.5	16.92	5.73	8.17	5.44	13.44	PMLL350
4"	24.5	16.92	5.98	8.17	5.44	13.44	PMLL400

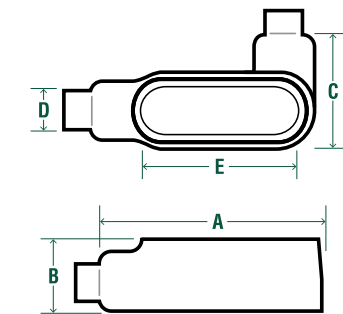

LR FORM 7

PIPE SIZE	FERROUS CATALOG #	NOMINAL WEIGHT	A	B	C	D	E	ALUMINUM CATALOG #
1/2"	PMLR17	1.2	4.60	1.42	2.29	0.94	3.19	PMLR17-A
3/4"	PMLR27	1.6	5.23	1.67	2.48	1.13	3.81	PMLR27-A
1"	PMLR37	2.1	6.04	1.92	2.79	1.38	4.50	PMLR37-A
1-1/4"	PMLR47	3.0	6.54	2.35	3.23	1.75	5.00	PMLR47-A
1-1/2"	PMLR57	4.1	7.17	2.60	3.60	1.94	5.44	PMLR57-A
2"	PMLR67	5.7	8.17	3.17	4.17	2.44	6.38	PMLR67-A
2-1/2"	PMLR77	10.0	10.54	3.67	5.79	3.56	8.38	PMLR77-A
3"	PMLR87	12.7	10.54	4.42	5.79	3.56	8.38	PMLR87-A
3-1/2"	PMLR97	19.0	12.73	4.92	6.98	4.50	10.25	PMLR97-A
4"	PMLR107	19.0	12.73	5.42	6.98	4.50	10.25	PMLR107-A

LR FORM 8

PIPE SIZE	FERROUS CATALOG #	NOMINAL WEIGHT	A	B	C	D	E
1/2"	PMLR50	1.4	4.98	1.48	2.20	1.00	3.31
3/4"	PMLR75	2.1	5.60	1.73	2.35	1.19	3.94
1"	PMLR100	2.6	6.51	1.98	2.67	1.38	4.56
1-1/4"	PMLR125	4.5	7.61	2.42	3.20	1.75	5.31
1-1/2"	PMLR150	6.2	9.17	2.82	4.04	2.13	6.50
2"	PMLR200	10.7	11.04	3.60	5.04	3.00	8.56
2-1/2"	PMLR250	17.7	13.98	4.48	6.73	4.25	10.88
3"	PMLR300	18.0	13.98	4.85	6.73	4.25	10.88

LR MARK 9

PIPE SIZE	NOMINAL WEIGHT	A	B	C	D	E	ALUMINUM CATALOG #
1/2"	1.4	4.63	1.42	2.17	1.19	3.31	PMLR50-A
3/4"	2.1	5.29	1.67	2.42	1.38	3.94	PMLR75-A
1"	2.6	6.13	1.92	2.67	1.50	4.56	PMLR100-A
1-1/4"	4.5	7.07	2.54	3.13	1.94	5.31	PMLR125-A
1-1/2"	6.2	7.79	2.79	3.48	2.25	6.00	PMLR150-A
2"	10.7	10.07	3.48	4.17	2.88	8.06	PMLR200-A
2-1/2"	17.7	13.98	4.48	6.73	4.25	10.88	PMLR250-A
3"	18.0	13.98	4.85	6.73	4.25	10.88	PMLR300-A
3-1/2"	21.0	16.92	5.73	8.17	5.44	13.44	PMLR350
4"	24.0	16.92	5.98	8.17	5.44	13.44	PMLR400

Conduit Bodies and Covers

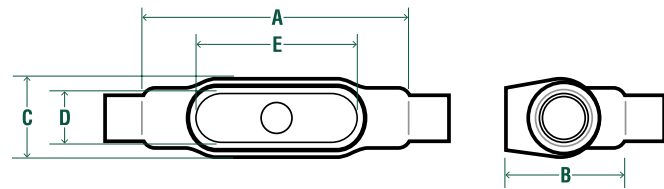

TB FORM 7

PIPE SIZE	FERROUS CATALOG #	NOMINAL WEIGHT	A	B	C	D	E	ALUMINUM CATALOG #
1/2"	PMTB17	1.6	5.63	2.63	1.64	0.94	3.19	PMTB17-A
3/4"	PMTB27	2.1	6.25	2.88	1.83	1.13	3.81	PMTB27-A
1"	PMTB37	2.7	7.25	3.25	2.08	1.38	4.50	PMTB37-A
1-1/4"	PMTB47	3.7	7.44	3.31	2.27	1.75	5.00	PMTB47-A
1-1/2"	PMTB57	4.7	8.19	5.00	2.52	1.94	5.44	PMTB57-A
2"	PMTB67	7.0	9.19	6.13	3.08	2.44	6.38	PMTB67-A

TB FORM 8

PIPE SIZE	FERROUS CATALOG #	NOMINAL WEIGHT	A	B	C	D	E
1/2"	PMTB50	2.0	5.69	2.53	1.46	1.00	3.31
3/4"	PMTB75	2.3	6.28	2.75	1.64	1.19	3.94
1"	PMTB100	3.1	7.31	3.13	1.83	1.38	4.56
1-1/4"	PMTB125	5.2	8.50	3.34	2.27	1.75	5.31
1-1/2"	PMTB150	7.0	10.38	4.03	2.83	2.13	6.50
2"	PMTB200	11.0	12.25	4.81	3.83	3.00	8.56

TB MARK 9

PIPE SIZE	NOMINAL WEIGHT	A	B	C	D	E	ALUMINUM CATALOG #
1/2"	2.0	5.00	2.13	1.46	1.19	3.31	PMTB50-A
3/4"	2.3	5.69	2.41	1.64	1.38	3.94	PMTB75-A
1"	3.1	6.59	2.84	1.83	1.50	4.56	PMTB100-A
1-1/4"	5.2	7.50	3.47	2.27	1.94	5.31	PMTB49
1-1/2"	7.0	8.34	3.88	2.58	2.16	5.88	PMTB59
2"	11.0	10.63	4.59	3.30	2.81	8.09	PMTB69

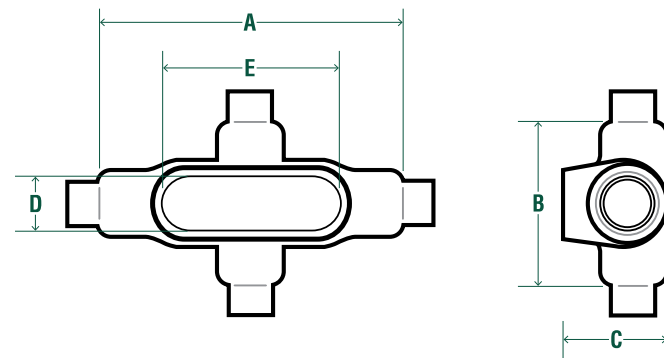

X FORM 7

PIPE SIZE	FERROUS CATALOG #	NOMINAL WEIGHT	A	B	C	D	E	ALUMINUM CATALOG #
1/2"	PMX17	1.7	5.63	3.31	1.79	0.94	3.19	PMX17-A
3/4"	PMX27	2.4	6.25	3.50	2.04	1.13	3.81	PMX27-A
1"	PMX37	2.7	7.25	4.00	2.29	1.38	4.50	PMX37-A
1-1/4"	PMX47	3.6	7.44	4.13	2.35	1.75	5.00	PMX47-A
1-1/2"	PMX57	5.0	8.19	4.63	2.60	1.94	5.44	PMX57-A
2"	PMX67	7.5	9.19	5.19	3.17	2.44	6.38	PMX67-A

X FORM 8

PIPE SIZE	FERROUS CATALOG #	NOMINAL WEIGHT	A	B	C	D	E
1/2"	PMX50	2.0	5.69	2.91	1.79	1.00	3.31
3/4"	PMX75	2.6	6.28	3.06	2.04	1.19	3.94
1"	PMX100	3.1	7.31	3.50	2.29	1.38	4.56
1-1/4"	PMX125	5.2	8.50	4.13	2.67	1.75	5.31
1-1/2"	PMX150	7.5	10.38	5.25	2.51	2.13	6.50
2"	PMX200	11.7	12.25	6.25	3.60	3.00	8.56

X MARK 9

PIPE SIZE	NOMINAL WEIGHT	A	B	C	D	E	ALUMINUM CATALOG #
1/2"	2.0	5.69	2.91	1.79	1.00	3.31	PMX50-A
3/4"	2.6	6.28	3.06	2.04	1.19	3.94	PMX75-A
1"	3.1	7.31	3.50	2.29	1.38	4.56	PMX100-A

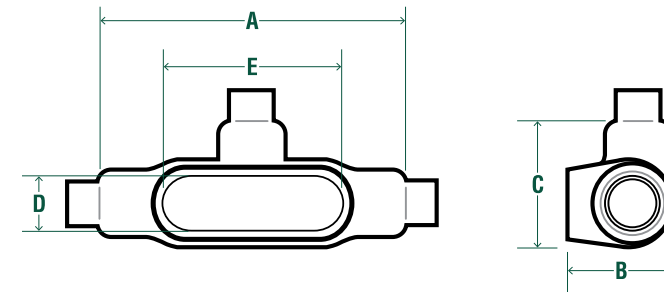

T FORM 7

PIPE SIZE	FERROUS CATALOG #	NOMINAL WEIGHT	A	B	C	D	E	ALUMINUM CATALOG #
1/2"	PMT17	1.5	5.63	1.79	2.48	0.94	3.19	PMT17-A
3/4"	PMT27	2.1	6.25	2.04	2.67	1.13	3.81	PMT27-A
1"	PMT37	2.9	7.25	2.29	3.04	1.38	4.50	PMT37-A
1-1/4"	PMT47	3.6	7.44	2.35	3.23	1.75	5.00	PMT47-A
1-1/2"	PMT57	4.5	8.19	2.60	3.60	1.94	5.44	PMT57-A
2"	PMT67	6.5	9.19	3.17	4.17	2.44	6.38	PMT67-A
2-1/2"	PMT77	10.7	12.00	3.67	5.79	3.56	8.38	PMT77-A
3"	PMT87	15.4	12.06	4.42	5.79	3.56	8.38	PMT87-A
3-1/2"	PMT97	19.0	14.31	4.92	6.98	4.50	10.25	PMT97-A
4"	PMT107	21.0	14.31	5.42	6.98	4.50	10.25	PMT107-A

T FORM 8

PIPE SIZE	FERROUS CATALOG #	NOMINAL WEIGHT	A	B	C	D	E
1/2"	PMT50	1.8	5.69	1.79	2.20	1.00	3.31
3/4"	PMT75	2.5	6.28	2.04	2.35	1.19	3.94
1"	PMT100	3.3	7.31	2.29	2.67	1.38	4.56
1-1/4"	PMT125	4.9	8.50	2.67	3.20	1.75	5.31
1-1/2"	PMT150	7.5	10.38	2.82	4.04	2.13	6.50
2"	PMT200	11.7	12.25	3.60	5.04	3.00	8.56
2-1/2"	PMT250	19.8	15.63	4.48	6.73	4.25	10.88
3"	PMT300	23.5	15.63	4.85	6.73	4.25	10.88

T MARK 9

PIPE SIZE	NOMINAL WEIGHT	A	B	C	D	E	ALUMINUM CATALOG #
1/2"	1.8	5.00	1.42	2.17	1.19	3.31	PMT50-A
3/4"	2.5	5.69	1.92	2.42	1.38	3.31	PMT75-A
1"	3.3	6.59	1.92	2.67	1.50	4.56	PMT100-A
1-1/4"	4.9	7.50	2.54	3.13	1.94	5.31	PMT125-A
1-1/2"	7.5	8.25	2.79	3.48	2.25	6.00	PMT150-A
2"	11.7	10.50	3.48	4.17	2.88	8.06	PMT200-A
2-1/2"	19.8	15.63	4.48	6.73	4.25	10.88	PMT250-A
3"	23.5	15.63	4.85	6.73	4.25	10.88	PMT300-A
3-1/2"	21.0	18.75	5.73	8.17	5.44	13.44	PMT350
4"	24.0	18.75	5.98	8.17	5.44	13.44	PMT400



REPLACEMENT SCREW KITS

CATALOG #	DESCRIPTION	QUANTITY
PMSCREW-KIT-1	1/2" and 3/4" Form 8 ENCAP Screws	2
PMSCREW-KIT-2	1" and 1-1/4" Form 8 ENCAP Screws	2
PMSCREW-KIT-3	1-1/2" Form 8 ENCAP Screws	2
PMSCREW-KIT-4	2" Form 8 ENCAP Screws	4
PMSCREW-KIT-5	2-1/2" and 3" Form 8 ENCAP Screws	4
PMSCREW-KIT-6	3-1/2" and 4" Form 8 ENCAP Screws	4
PMSCREW-KIT-7	1/2" OE ENCAP Screws	4
PMSCREW-KIT-8	3/4" OE ENCAP Screws	4
PMSCREW-KIT-9	1-1/4" LBD ENCAP Screws	4
PMSCREW-KIT-10	1-1/2" LBD ENCAP Screws	4
PMSCREW-KIT-11	2" LBD ENCAP Screws	4
PMSCREW-KIT-12	2-1/2" and 3" LBD ENCAP Screws	6
PMSCREW-KIT-13	2-1/2" and 3" Mark 9 ENCAP Screws	4
PMSCREW-KIT-14	3-1/2" and 4" Mark 9 ENCAP Screws	4

FORM 7 COVERS

PART #	DESCRIPTION
PM170	1/2 FORM 7 COVER
PM170-A	1/2 AL FORM 7 COVER
PM270	3/4 FORM 7 COVER
PM270-A	3/4 FORM 7 AL COVER
PM370	1 FORM 7 COVER
PM370-A	1 AL FORM 7 COVER
PM470	1-1/4 FORM 7 COVER
PM470-A	1-1/4 AL FORM 7 COVER
PM570	1-1/2 FORM 7 COVER
PM570-A	1-1/2 AL FORM 7 COVER
PM670	2 FORM 7 COVER
PM670-A	2 AL FORM 7 COVER
PM870	2-1/2 - 3 FORM 7 COVER
PM870-A	2-1/2 - 3 FORM 7 AL COVER
PM970	3-1/2 - 4 FORM 7 COVER
PM970-A	3-1/2 - 4 FORM 7 COVER

FORM 8 COVERS

PART #	DESCRIPTION
PMBC100G	1/2 FORM 8 COVER
PMBC125G	3/4 FORM 8 COVER
PMBC150G	1 FORM 8 COVER
PMBC200G	1-1/4 FORM 8 COVER
PMBC250G	1-1/2 FORM 8 COVER
PMBC350G	2 FORM 8 COVER
PMBC50G	2-1/2 - 3 FORM 8 COVER
PMBC75G	3-1/2 - 4 FORM 8 COVER

MARK 9 COVERS

PART #	DESCRIPTION
PMBC50-A	1/2 MARK 9 COVER
PMBC75-A	3/4 MARK 9 COVER
PMBC100-A	1 MARK 9 COVER
PMBC125-A	1-1/4 MARK 9 COVER
PMBC150-A	1-1/2 MARK 9 COVER
PMBC200-A	2 MARK 9 COVER
PMBC300-A	2-1/2 - 3 MARK 9 COVER
PMBC350-A	3-1/2 - 4 MARK 9 COVER

LBD Pulling Elbows

Mogul Style Conduit Bodies



DESCRIPTION

Perma-Cote LBD conduit bodies are used at 90° bends in conduit runs to allow straight pulls at bends, to serve as pull outlets for stiff conductors, to allow for service entrance into buildings, or to allow conductor entrance into motors. Electrical continuity of the conduit system is maintained across assembled joints.

FEATURES

- 40 mil gray PVC exterior coating
- 2 mil green urethane interior coating
- 10 trade sizes from 1/2" through 4"
- Sealing sleeves on all female conduit openings
- Molded-in seal between body and cover
- Domed covers allow gentle bends of conductors
- Shipped with covers
- Angled covers allow straight pulling in either direction

STANDARDS

Ferrous Only

- UL 514B (E200413)

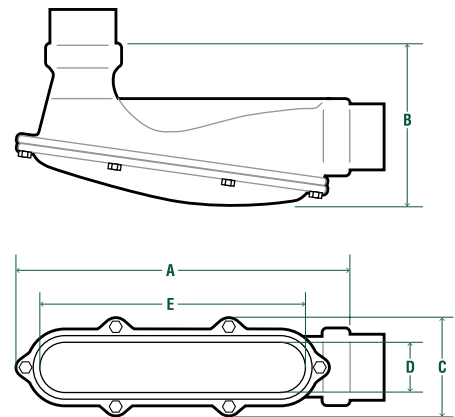

PIPE SIZE	FERROUS CATALOG #	NOMINAL WEIGHT	A	B	C	D	E	ALUMINUM CATALOG #
1/2"	PMLBD-1100	1.2	5.00	2.35	1.39	1.00	3.34	PMLBD-1100-A
3/4"	PMLBD-2200	2.0	6.25	2.67	1.64	1.25	4.53	PMLBD-2200-A
1"	PMLBD-3300	2.5	6.25	2.98	1.89	1.50	4.34	PMLBD-3300-A
1-1/4"	PMLBD-4400	6.0	8.63	4.29	3.58	1.81	7.19	PMLBD-4400-A
1-1/2"	PMLBD-5500	11.5	12.44	5.48	4.71	2.63	10.88	PMLBD-5500-A
2"	PMLBD-6600	18.0	12.44	5.48	4.71	2.63	10.88	PMLBD-6600-A
2-1/2"	PMLBD-7700	22.0	19.69	9.60	5.71	3.00	15.75	PMLBD-7700-A
3"	PMLBD-8800	35.0	19.69	9.60	5.71	3.00	15.75	PMLBD-8800-A
3-1/2"	PMLBD-9900	60.0	20.88	10.92	7.83	4.75	19.89	-
3-1/2"	-	-	27.81	11.92	7.21	4.00	24.00	PMLBD-9900-A
4"	PMLBD-10900	70.0	20.88	10.92	7.83	4.75	19.89	-
4"	-	-	27.81	11.92	7.21	4.00	24.00	PMLBD-10900-A

DESCRIPTION

Perma-Cote mogul style conduit bodies are offered in various configurations to provide a complete coated conduit system. Mogul BG Covers are sold separately. Mogul style fitting bodies have long openings and may be used to make bends in conduit runs, for pull outlets for stiff conductors, to provide additional room for taps or splices, etc. Electrical continuity of the conduit system is maintained across assembled joints.

FEATURES

- 40 mil gray PVC exterior coating
- 2 mil green urethane interior coating
- 8 trade sizes from 1" through 4"
- Sealing sleeves on all female conduit openings
- Molded-in seal between bodies and covers
- Large cover openings provide ample room

STANDARDS

Ferrous and Aluminum

- UL 514A, 514B, 514D (E231035)
- CSA C22.2 No. 18, CSA C22.2 No. 42

Mogul Style Conduit Bodies

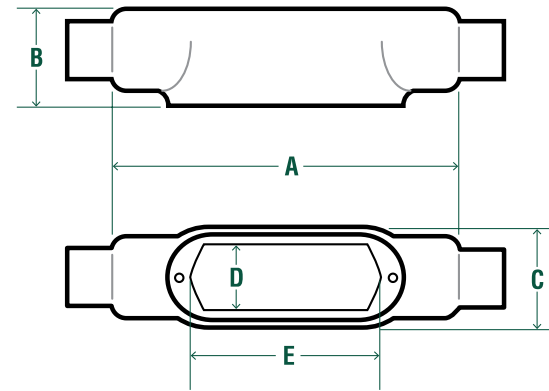

BC

PIPE SIZE	FERROUS CATALOG #	NOMINAL WEIGHT	A	B	C	D	E	ALUMINUM CATALOG #
1"	PMC8X100G	3.2	9.56	1.92	2.27	1.88	6	PMC8X100-A
1-1/4"	PMC8X125G	4.2	9.56	2.35	2.27	1.88	6	PMC8X125-A
1-1/2"	PMC8X150G	6.0	13.75	2.60	3.08	2.63	10	PMC8X150-A
2"	PMC8X200G	7.0	13.75	3.17	3.08	2.63	10	PMC8X200-A
2-1/2"	PMC8X250G	13.8	18.38	3.67	4.33	3.81	15	PMC8X250-A
3"	PMC8X300G	17.5	18.38	4.42	4.33	3.81	15	PMC8X300-A
3-1/2"	PMC8X350G	25.0	23.75	4.92	5.33	4.75	20	PMC8X350-A
4"	PMC8X400G	28.0	23.75	5.42	5.33	4.75	20	PMC8X400-A

(Cover sold separately.)

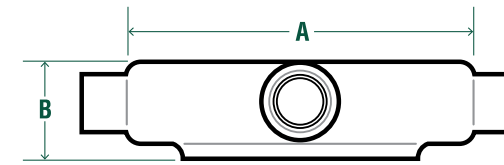

BT

PIPE SIZE	FERROUS CATALOG #	NOMINAL WEIGHT	A	B	C	D	E	ALUMINUM CATALOG #
1"	PMT8X100G	3.2	9.56	1.92	3.24	1.88	6	PMT8X100-A
1-1/4"	PMT8X125G	3.6	9.56	2.35	3.24	1.88	6	PMT8X125-A
1-1/2"	PMT8X150G	7.5	13.75	2.60	4.14	2.63	10	PMT8X150-A
2"	PMT8X200G	9.0	13.75	3.17	4.14	2.63	10	PMT8X200-A
2-1/2"	PMT8X250G	15.0	18.38	3.67	5.67	3.81	15	PMT8X250-A
3"	PMT8X300G	19.0	18.38	4.42	5.80	3.81	15	PMT8X300-A
3-1/2"	PMT8X350G	29.0	23.75	4.92	6.96	4.75	20	PMT8X350-A
4"	PMT8X400G	32.0	23.75	5.42	6.96	4.75	20	PMT8X400-A

(Cover sold separately.)

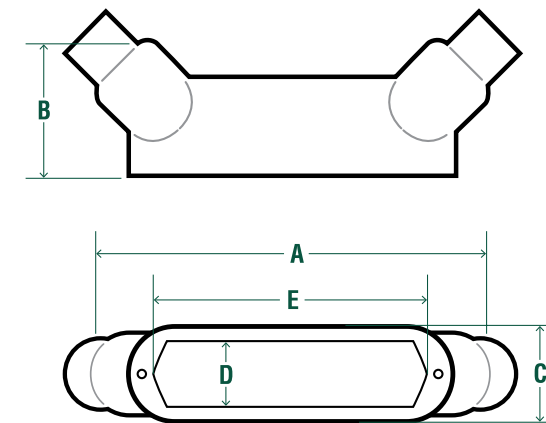

BUB

PIPE SIZE	FERROUS CATALOG #	NOMINAL WEIGHT	A	B	C	D	E	ALUMINUM CATALOG #
1"	PMUB6X100G	3.2	9.19	2.69	2.27	1.88	6	PMUB6X100-A
1-1/4"	PMUB6X125G	4.0	9.31	3.19	2.27	1.88	6	PMUB6X125-A
1-1/2"	PMUB6X150G	5.9	13.50	3.50	3.08	2.63	10	PMUB6X150-A
2"	PMUB6X200G	7.8	13.50	4.13	3.08	2.63	10	PMUB6X200-A
2-1/2"	PMUB6X250G	12.5	17.75	4.81	4.33	3.81	15	PMUB6X250-A
3"	PMUB6X300G	17.0	17.88	5.63	4.33	3.81	15	PMUB6X300-A
3-1/2"	PMUB6X350G	25.0	23.38	6.38	5.33	4.75	20	PMUB6X350-A
4"	PMUB6X400G	28.0	23.25	6.81	5.33	4.75	20	PMUB6X400-A

(Cover sold separately.)

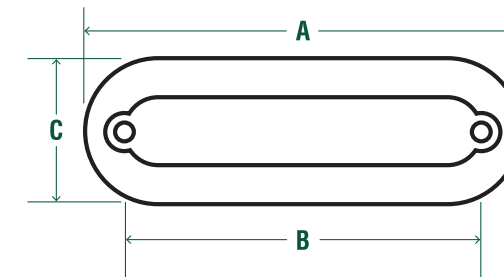

MOGUL STYLE BG COVERS

FERROUS CATALOG #	DESCRIPTION	NOMINAL WEIGHT	ALUMINUM CATALOG #
PMBG48	1 - 1-1/4 BG COVER MOGUL	2.5	PMBG48-A
PMBG68	1-1/2 - 2 BG COVER MOGUL	3.2	PMBG68-A
PMBG88	2-1/2 - 3 BG COVER MOGUL	6.4	PMBG88-A
PMBG98	3-1/2 - 4 BG COVER MOGUL	9.8	PMBG98-A

(Body sold separately.)

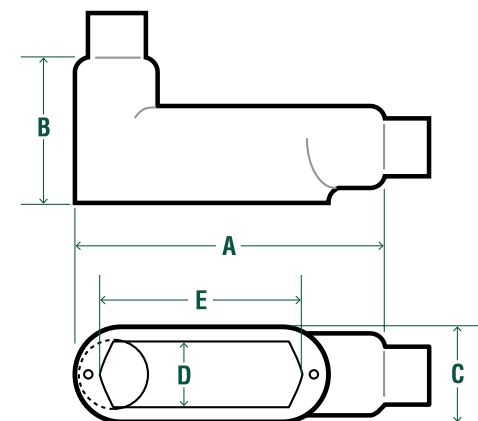
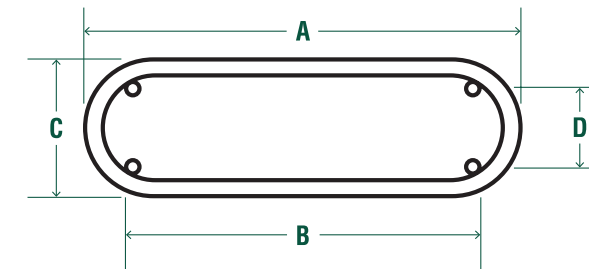

BLB

PIPE SIZE	FERROUS CATALOG #	NOMINAL WEIGHT	A	B	C	D	E	ALUMINUM CATALOG #
1"	PMLB6X100G	3.2	8.63	2.84	2.27	1.88	6	PMLB6X100-A
1-1/4"	PMLB6X125G	4.2	8.63	3.28	2.27	1.88	6	PMLB6X125-A
1-1/2"	PMLB6X150G	6.0	12.73	3.63	3.08	2.63	10	PMLB6X150-A
2"	PMLB6X200G	7.0	12.73	4.19	3.08	2.63	10	PMLB6X200-A
2-1/2"	PMLB6X250G	13.8	16.95	5.09	4.33	3.81	15	PMLB6X250-A
3"	PMLB6X300G	17.5	16.95	5.84	4.33	3.81	15	PMLB6X300-A
3-1/2"	PMLB6X350G	25.0	22.17	6.50	5.33	4.75	20	PMLB6X350-A
4"	PMLB6X400G	28.0	22.17	7.00	5.33	4.75	20	PMLB6X400-A

(Cover sold separately.)

Knockout Hubs

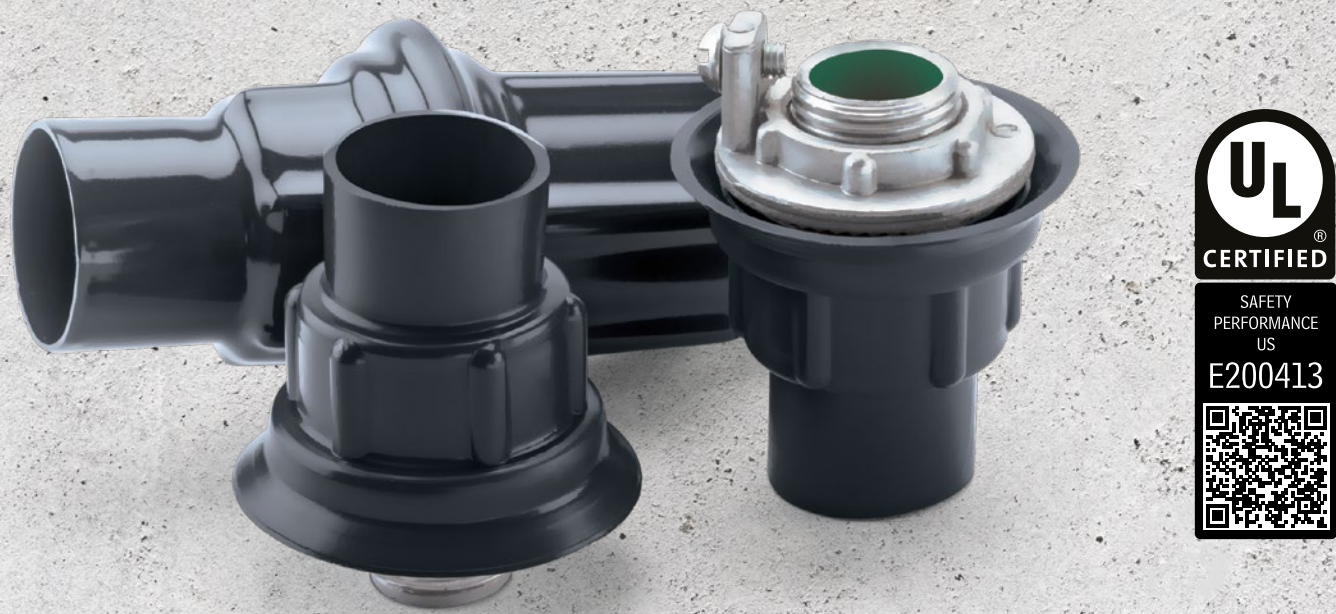

DESCRIPTION

Perma-Cote ST style knockout hubs are used to terminate conduit runs through the wall of an electrical enclosure. They are available with or without grounding lug. STTB style hubs are "through-bulkhead" fittings used to pass conduit runs through firewalls or bulkheads up to 1/8" thick. STTTB style hubs perform the same function for unlimited wall thicknesses, (furnished without nipples).

FEATURES

- 40 mil gray PVC exterior coating
- ST available in 12 trade sizes from 1/2" through 6"
- STTB available in 10 trade sizes from 1/2" through 4"
- STTTB available in 6 trade sizes from 1/2" through 2"
- Sealing sleeves on conduit side of hub
- Molded PVC gasket seals flush with enclosure wall
- O-ring gasket provides additional seal

STANDARDS

Zinc Only: ST, STG

- UL 514B (E200413)
- NEC/CEC:
 - Class I, Division 2
 - Class II, Division 1 & 2
 - Class III, Division 1 & 2

NOTE: All screw-tight hubs are listed for NEMA and UL type enclosures 2, 3, 3R, 4, 4X, 11, and 12. Grounding and bonding hubs are listed for NEMA Enclosures 2, 3, 3R, 4, 4X, and 12.



INSTALLATION TIP!

Conduit layout is critical, plan for proper spacing at the termination point to ensure adequate room for installation.

ST

PIPE SIZE	CATALOG #	NOMINAL WEIGHT	A	B	C	MAX WALL THICK	ALUMINUM CATALOG #
1/2"	PMST-1	0.2	1.34	2.00	0.81	0.19	PMSTA-1
3/4"	PMST-2	0.3	1.47	2.25	0.91	0.19	PMSTA-2
1"	PMST-3	0.4	1.66	2.50	1.03	0.25	PMSTA-3
1-1/4"	PMST-4	0.4	1.69	3.25	1.03	0.25	PMSTA-4
1-1/2"	PMST-5	0.6	1.69	3.50	1.03	0.25	PMSTA-5
2"	PMST-6	1.2	1.75	4.25	1.09	0.25	PMSTA-6
2-1/2"	PMST-7	1.5	2.22	4.75	1.28	0.25	PMSTA-7
3"	PMST-8	2.1	2.31	5.25	1.38	0.25	PMSTA-8
3-1/2"	PMST-9	3.0	2.38	5.50	1.44	0.25	PMSTA-9
4"	PMST-10	3.5	2.44	6.25	1.50	0.25	PMSTA-10
5"	PMST-11	5.4	2.94	7.50	2.00	0.25	PMSTA-11
6"	PMST-12	6.9	3.00	8.50	2.00	0.31	PMSTA-12

STG

PIPE SIZE	CATALOG #	NOMINAL WEIGHT	A	B	C	MAX WALL THICK	ALUMINUM CATALOG #
1/2"	PMSTG-1	0.2	1.34	2.00	0.81	0.19	PMSTAG-1
3/4"	PMSTG-2	0.3	1.47	2.25	0.91	0.19	PMSTAG-2
1"	PMSTG-3	0.4	1.66	2.50	1.03	0.25	PMSTAG-3
1-1/4"	PMSTG-4	0.4	1.69	3.25	1.03	0.25	PMSTAG-4
1-1/2"	PMSTG-5	0.6	1.69	3.50	1.03	0.25	PMSTAG-5
2"	PMSTG-6	1.2	1.75	4.25	1.09	0.25	PMSTAG-6
2-1/2"	PMSTG-7	1.5	2.22	4.75	1.28	0.25	PMSTAG-7
3"	PMSTG-8	2.1	2.31	5.25	1.38	0.25	PMSTAG-8
3-1/2"	PMSTG-9	3.0	2.38	5.50	1.44	0.25	PMSTAG-9
4"	PMSTG-10	3.5	2.44	6.25	1.50	0.25	PMSTAG-10
5"	PMSTG-11	5.4	2.94	7.50	2.00	0.25	PMSTAG-11
6"	PMSTG-12	6.9	3.00	8.50	2.00	0.31	PMSTAG-12

STTB

PIPE SIZE	CATALOG #	NOMINAL WEIGHT	A	B	MAX WALL THICK	ALUMINUM CATALOG #
1/2"	PMSTTB-1	0.5	1.34	2.00	0.19	PMSTTBA-1
3/4"	PMSTTB-2	0.5	1.47	2.25	0.19	PMSTTBA-2
1"	PMSTTB-3	0.7	1.66	2.50	0.25	PMSTTBA-3
1-1/4"	PMSTTB-4	1.0	1.69	3.25	0.25	PMSTTBA-4
1-1/2"	PMSTTB-5	1.2	1.69	3.5	0.25	PMSTTBA-5
2"	PMSTTB-6	1.7	1.75	4.25	0.25	PMSTTBA-6
2-1/2"	PMSTTB-7	2.5	2.22	4.75	0.25	PMSTTBA-7
3"	PMSTTB-8	3.0	2.31	5.25	0.25	PMSTTBA-8
3-1/2"	PMSTTB-9	4.2	2.38	5.50	0.25	-
4"	PMSTTB-10	5.9	2.44	6.25	0.25	-

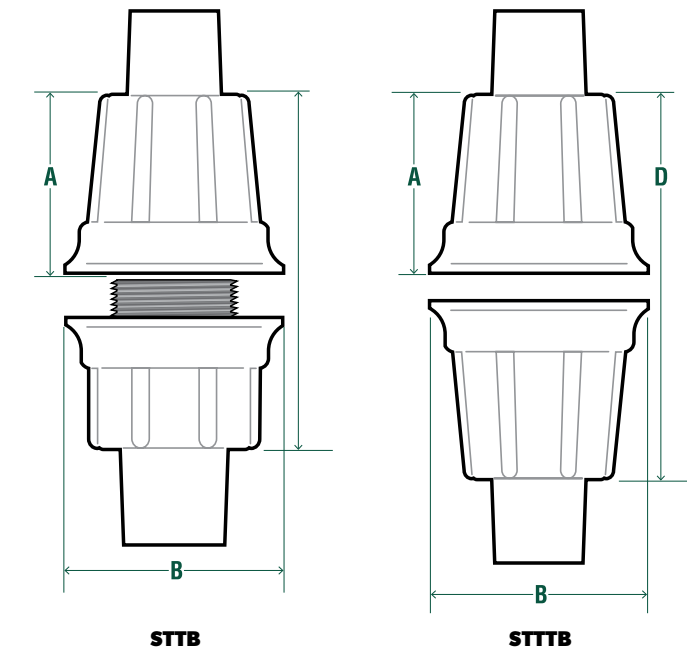
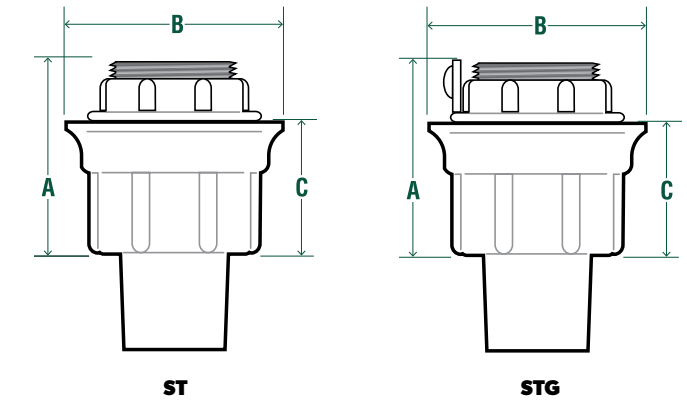

STTTB

PIPE SIZE	CATALOG #	NOMINAL WEIGHT	A	B	MAX WALL THICK	ALUMINUM CATALOG #
1/2"	PMSTTTB-1	1.0	1.34	2.00	*	PMSTTTBA-1
3/4"	PMSTTTB-2	1.0	1.47	2.25	*	PMSTTTBA-2
1"	PMSTTTB-3	1.4	1.66	2.50	*	PMSTTTBA-3
1-1/4"	PMSTTTB-4	2.0	1.69	3.25	*	PMSTTTBA-4
1-1/2"	PMSTTTB-5	2.4	1.69	3.50	*	PMSTTTBA-5
2"	PMSTTTB-6	3.4	1.75	4.25	*	PMSTTTBA-6

* Unlimited wall thickness - determined by nipple used.

Liquid Tight Connectors



FEATURES

- 40 mil gray PVC exterior coating
- 2 mil green urethane interior coating
- 10 trade sizes from 3/8" through 4"
- Sealing sleeves on all female conduit openings
- Available in straight, 45°, or 90° body configurations
- Available with an external grounding lug

STANDARDS

Ferrous Only

- UL 514B (E200413)
- UL 467 (E217890): 3/8" to 1"

DESCRIPTION

Perma-Cote liquid tight connectors are used to wire motors, transformers, processing equipment, pumps, etc. The flexible conduit and the PVC-coated connector work together to seal out water and other corrosive liquids, protecting the conductors from damage.

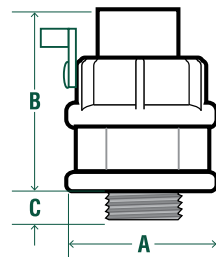
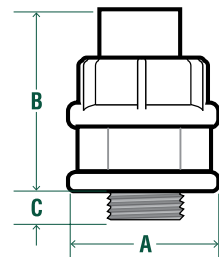

STRAIGHT CONNECTOR

PIPE SIZE	FERROUS CATALOG #	A	B	C	NOMINAL WEIGHT	ALUMINUM CATALOG #
3/8"	PM4Q38T	1.24	1.50	0.56	0.2	PM4Q38T-A
1/2"	PM4Q50T	1.46	1.56	0.56	0.2	PM4Q50T-A
3/4"	PM4Q75T	1.74	1.63	0.56	0.3	PM4Q75T-A
1"	PM4Q100T	1.96	2.06	0.75	0.4	PM4Q100T-A
1-1/4"	PM4Q125T	2.36	2.50	0.81	0.8	PM4Q125T-A
1-1/2"	PM4Q150T	2.80	2.69	0.81	0.9	PM4Q150T-A
2"	PM4Q200T	3.33	3.06	0.88	1.7	PM4Q200T-A
2-1/2"	PM4Q250T	3.83	4.13	1.00	3.0	PM4Q250T-A
3"	PM4Q300T	4.58	4.25	1.00	4.2	PM4Q300T-A
4"	PM4Q350T	5.58	4.50	1.13	6.2	PM4Q350T-A

STRAIGHT CONNECTOR WITH GROUND

PIPE SIZE	FERROUS CATALOG #	A	B	C	NOMINAL WEIGHT	ALUMINUM CATALOG #
3/8"	PM4Q38LT	1.24	1.50	0.56	0.2	PM4Q38LT-A
1/2"	PM4Q50LT	1.46	1.56	0.56	0.2	PM4Q50LT-A
3/4"	PM4Q75LT	1.74	1.63	0.56	0.3	PM4Q75LT-A
1"	PM4Q100LT	1.96	2.06	0.75	0.4	PM4Q100LT-A
1-1/4"	PM4Q125LT	2.33	2.50	0.81	0.8	PM4Q125LT-A
1-1/2"	PM4Q150LT	3.33	2.69	0.81	0.9	PM4Q150LT-A
2"	PM4Q200LT	3.89	3.06	0.88	1.7	PM4Q200LT-A
2-1/2"	PM4Q250LT	4.52	4.13	1.00	3.0	PM4Q250LT-A
3"	PM4Q300LT	5.27	4.25	1.00	4.2	PM4Q300LT-A
4"	PM4Q350LT	6.21	4.50	1.13	6.2	PM4Q350LT-A

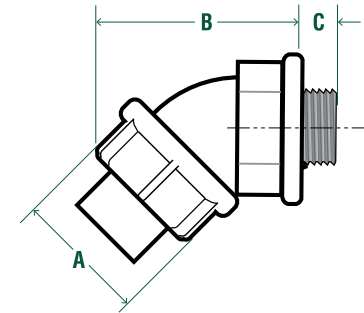

45° CONNECTOR

PIPE SIZE	FERROUS CATALOG #	A	B	C	NOMINAL WEIGHT
3/8"	PM4Q38T	1.24	1.56	0.56	0.3
1/2"	PM4Q450T	1.46	1.88	0.56	0.3
3/4"	PM4Q475T	1.74	2.13	0.56	0.4
1"	PM4Q4100T	1.96	2.25	0.75	0.5
1-1/4"	PM4Q4125T	2.36	2.75	0.81	1.5
1-1/2"	PM4Q4150T	2.8	3.38	0.81	1.2
2"	PM4Q4200T	3.33	3.88	0.88	2.0
2-1/2"	PM4Q4250T	3.83	4.25	1.00	3.0
3"	PM4Q4300T	4.58	4.25	1.00	4.2
4"	PM4Q4400T	5.58	4.63	1.13	6.2

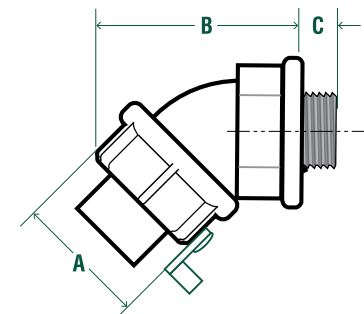

45° CONNECTOR WITH GROUND

PIPE SIZE	FERROUS CATALOG #	A	B	C	NOMINAL WEIGHT
3/8"	PM4Q438LT	1.24	1.56	0.56	0.3
1/2"	PM4Q450LT	1.46	1.88	0.56	0.3
3/4"	PM4Q475LT	1.74	2.13	0.56	0.4
1"	PM4Q4100LT	1.96	2.25	0.75	0.5
1-1/4"	PM4Q4125LT	2.33	2.75	0.81	1.5
1-1/2"	PM4Q4150LT	3.33	3.38	0.81	1.2
2"	PM4Q4200LT	3.89	3.88	0.88	2.0
2-1/2"	PM4Q4250LT	4.52	4.25	1.00	3.0
3"	PM4Q4300LT	5.27	4.25	1.00	4.2
4"	PM4Q4400LT	6.21	4.63	1.13	6.2

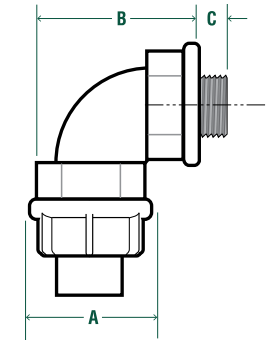

90° CONNECTOR

PIPE SIZE	FERROUS CATALOG #	A	B	C	NOMINAL WEIGHT	ALUMINUM CATALOG #
3/8"	PM4Q938T	1.24	1.38	0.56	0.3	PM4Q938T-A
1/2"	PM4Q950T	1.46	1.56	0.56	0.3	PM4Q950T-A
3/4"	PM4Q975T	1.74	1.75	0.56	0.4	PM4Q975T-A
1"	PM4Q9100T	1.96	2.19	0.75	0.6	PM4Q9100T-A
1-1/4"	PM4Q9125T	2.36	2.75	0.81	1.0	PM4Q9125T-A
1-1/2"	PM4Q9150T	2.80	2.94	0.81	1.7	PM4Q9150T-A
2"	PM4Q9200T	3.33	3.44	0.88	2.7	PM4Q9200T-A
2-1/2"	PM4Q9250T	3.83	8.88	1.00	3.8	-
3"	PM4Q9300T	4.58	10.25	1.00	4.2	-
4"	PM4Q9400T	5.58	12.63	1.13	6.2	-

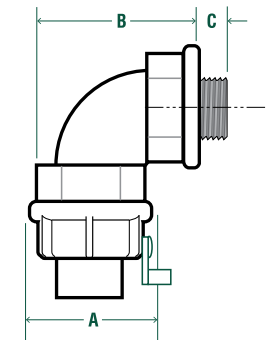

90° CONNECTOR WITH GROUND

PIPE SIZE	FERROUS CATALOG #	A	B	C	NOMINAL WEIGHT	ALUMINUM CATALOG #
3/8"	PM4Q938LT	1.24	1.25	0.56	0.3	PM4Q938LT-A
1/2"	PM4Q950LT	1.46	1.44	0.56	0.3	PM4Q950LT-A
3/4"	PM4Q975LT	1.74	1.81	0.56	0.4	PM4Q975LT-A
1"	PM4Q9100LT	1.96	2.06	0.75	0.6	PM4Q9100LT-A
1-1/4"	PM4Q9125LT	2.33	2.50	0.81	1.0	PM4Q9125LT-A
1-1/2"	PM4Q9150LT	3.33	2.94	0.81	1.7	PM4Q9150LT-A
2"	PM4Q9200LT	3.89	3.44	0.88	2.7	PM4Q9200LT-A
2-1/2"	PM4Q9250LT	4.52	8.88	1.00	3.8	-
3"	PM4Q9300LT	5.27	10.25	1.00	4.2	-
4"	PM4Q9400LT	6.21	12.63	1.13	6.2	-

LTR Combination Couplings



DESCRIPTION

PVC Coated LTR Combination Couplings are used with liquid tight conduit. The LTR combination coupling allows the installer to transition from flexible conduit to threaded rigid conduit. The LTR fitting can also be used when transitioning from flexible conduit to fittings with female openings. Note a short nipple will be required since the LTR fittings is female/female.

LTR COMBINATION COUPLING

PIPE SIZE	FERROUS CATALOG #
PMLTR50	1/2"
PMLTR75	3/4"
PMLTR100	1"
PMLTR125	1-1/4"
PMLTR150	1-1/2"
PMLTR200	2"



INSTALLATION TIP!

If using a liquid tight fitting in conjunction with a conduit body, never remove the sleeve of the conduit body. Instead, use a LTR fitting in conjunction with a short nipple to create the transition.

FEATURES

- 40 mil gray PVC exterior coating
- 2 mil green urethane interior coating
- Trade sizes 1/2" through 2"
- Sealing sleeves on all conduit openings
- Available with an external grounding lug

LTR COMBINATION COUPLING WITH GROUND

PIPE SIZE	FERROUS CATALOG #
PMLTR50G	1/2"
PMLTR75G	3/4"
PMLTR100G	1"
PMLTR125G	1-1/4"
PMLTR150G	1-1/2"
PMLTR200G	2"

TECK Series Cable Fittings

DESCRIPTION

Perma-Cote TECK Series cable fittings are designed for use with jacketed TECK cable with aluminum or steel armor. TECK series cable fittings are installed to provide a means for passing TECK type cable into an enclosure, panel board, or other equipment, to form a mechanical watertight and dust tight termination, and to provide ground continuity between the cable armour and metal enclosures.

FEATURES

- 40 mil gray PVC exterior coating with cable sleeve and sealing gland
- Standard material is aluminum
- Stainless steel copper-plated spring provides grounding continuity of cable armour (TECK cable only)
- Watertight seal on outer sheath of cable
- Standard neoprene seal suitable for use in operating temperatures -25° to 60°C
- An integral o-ring seal on entry threads
- Available with NPT threads

Gland Type

- Armoured

Cable Type

- TECK Armoured

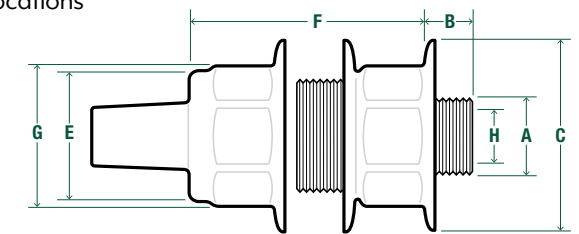
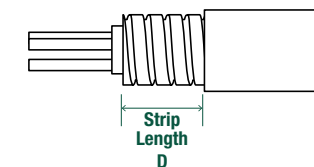

STANDARDS

- Class II, Div. 1 & 2, Groups E, F, G; Class III
- Type 4 and IP56
- Wet locations

PVC COATED ALUMINUM CATALOG #	ENTRY THREAD SIZE A NPT SIZE	THREAD LENGTH B NPT	CABLE ACCEPTANCE		GLAND LENGTH F (LESS ENTRY)	HEXAGON DIMENSIONS					
			ARMOR RANGE H MIN	OUTER SHEATH E MAX		ACROSS FLATS	ACROSS CORNERS G	SEALING GLAND C	STRIP LENGTH D		
PMTECK050-1	1/2"	0.630	0.415	0.570	0.525	0.650	2.300	1.250	1.350	1.925	1-1/4"
PMTECK050-2	1/2"	0.630	0.490	0.680	0.600	0.760	2.300	1.375	1.500	1.925	1-1/4"
PMTECK050-3	1/2"	0.630	0.615	0.805	0.725	0.885	2.300	1.500	1.600	1.925	1-1/4"
PMTECK050-4	1/2"	0.630	0.715	0.905	0.825	0.985	2.300	1.500	1.600	1.925	1-1/4"
PMTECK075-5	3/4"	0.630	0.770	0.985	0.880	1.065	2.500	2.000	2.125	2.000	1-1/4"
PMTECK075-6	3/4"	0.630	0.915	1.125	1.025	1.205	2.500	2.000	2.125	2.000	1-1/4"
PMTECK100-7	1"	0.750	1.077	1.295	1.187	1.375	2.625	2.250	2.400	2.370	1-1/4"
PMTECK125-8	1-1/4"	0.800	1.240	1.545	1.350	1.625	3.500	3.000	3.125	2.370	1-3/4"
PMTECK125-9	1-1/4"	0.800	1.390	1.545	1.500	1.625	3.400	3.000	3.125	2.370	1-3/4"
PMTECK125-10	1-1/4"	0.800	1.490	1.795	1.600	1.875	3.500	3.000	3.125	2.870	1-3/4"
PMTECK150-11	1-1/2"	0.800	1.590	1.885	1.700	1.965	3.800	3.750	3.600	3.750	1-3/4"
PMTECK150-12	1-1/2"	0.800	1.790	2.107	1.900	2.187	3.900	3.500	3.750	3.250	1-3/4"
PMTECK200-13	2"	0.825	1.790	2.107	1.900	2.187	4.000	3.750	4.000	3.750	1-3/4"
PMTECK200-14	2"	0.825	1.990	2.280	2.100	2.375	4.000	3.750	4.000	3.750	1-3/4"
PMTECK200-15	2"	0.875	2.190	2.485	2.300	2.565	4.000	4.125	4.400	3.750	1-3/4"
PMTECK200-16	2"	0.875	2.390	2.656	2.500	2.750	4.000	4.125	4.400	3.750	1-3/4"
PMTECK250-17	2-1/2"	1.300	2.240	2.560	2.380	2.640	5.000	4.500	4.750	4.500	2-1/2"
PMTECK250-18	2-1/2"	1.300	2.440	2.750	2.580	2.840	5.000	4.500	4.750	4.500	2-1/2"
PMTECK300-19	3"	1.400	2.640	2.970	2.790	3.060	5.000	4.600	4.900	5.000	2-1/2"
PMTECK300-20	3"	1.400	2.870	3.190	3.000	3.270	5.000	4.900	5.250	5.000	2-1/2"
PMTECK300-21	3"	1.400	3.042	3.390	3.210	3.480	5.000	5.000	5.250	5.000	2-1/2"
PMTECK350-22	3-1/2"	1.400	3.270	3.590	3.420	3.690	5.000	5.600	5.900	5.500	2-1/2"
PMTECK350-23	3-1/2"	1.400	3.440	3.770	3.610	3.870	5.000	5.500	5.900	5.500	2-1/2"
PMTECK400-24	4"	1.400	3.600	3.930	3.810	4.030	5.000	6.125	6.500	6.100	2-1/2"
PMTECK400-25	4"	1.400	3.755	4.065	3.965	4.185	5.000	6.125	6.500	6.100	2-1/2"
PMTECK400-26	4"	1.400	3.910	4.220	4.120	4.340	5.000	6.125	6.500	6.100	2-1/2"

Grounding Bushings



PIPE SIZE	FERROUS CATALOG #	NOMINAL WEIGHT
1/2"	PMGLL1	0.1
3/4"	PMGLL2	0.1
1"	PMGLL3	0.1
1-1/4"	PMGLL4	0.2
1-1/2"	PMGLL5	0.2
2"	PMGLL6	0.3
2-1/2"	PMGLL7	0.5
3"	PMGLL8	0.7
3-1/2"	PMGLL9	1.0
4"	PMGLL10	1.1

DESCRIPTION

Perma-Cote grounding bushings are used on threaded PVC-coated rigid conduit to provide a means of grounding conduit through an insulated bushing.

FEATURES

- 40 mil gray PVC exterior coating
- 2 mil green urethane interior coating
- 10 trade sizes from 1/2" through 4"
- Aluminum lug for copper or aluminum grounding conductor
- Screws are zinc-plated steel

Reducing Bushings



DESCRIPTION

RE style reducers reduce conduit hubs to a smaller size. They are provided with an integral bushing to prevent conductor damage and full, clean cut threads for ease of assembly.

All RE reducers are coated at the edges with green polyurethane for corrosion protection.

STANDARDS

- NEC/CEC:
 - Class I, Division 1 & 2, Groups A, B, C, D
 - Class II, Division 1, Groups E, F, G
 - Class II, Division 2, Groups F, G
 - Class III
- *Class I, Division 2 Group A & B
- +Class I, Division 1 & 2, Group B

NOTE: REs and PLGs meet the above standards only when used in conjunction with hazardous location fittings and when installed in accordance of NEC® and local code requirements.

Split Couplings



PIPE SIZE	FERROUS CATALOG #	NOMINAL WEIGHT
1/2"	PMSSP-50	0.2
3/4"	PMSSP-75	0.3
1"	PMSSP-100	0.4
1-1/4"	PMSSP-125	0.6
1-1/2"	PMSSP-150	0.7
2"	PMSSP-200	1.0
2-1/2"	PMSSP-250	2.3
3"	PMSSP-300	3.0
3-1/2"	PMSSP-350	3.8
4"	PMSSP-400	4.1
5"	PMSSP-500	6.0
6"	PMSSP-600	8.6

DESCRIPTION

Perma-Cote split couplings are used to connect two pieces of conduit where the conduit can't be turned because of limited clearance between runs or a wall, or other obstruction.

FEATURES

- 40 mil gray PVC exterior coating
- 2 mil green urethane interior coating
- 12 trade sizes from 1/2" through 6"
- Sealing sleeves on all female conduit openings

PIPE SIZE	FERROUS CATALOG #	NOMINAL WEIGHT	ALUMINUM CATALOG #
3/4" - 1/2"	*PMRE21	0.2	PMRE21SA
1" - 1/2"	*PMRE31	0.7	PMRE31SA
1" - 3/4"	*PMRE32	0.5	PMRE32SA
1-1/4" - 1/2"	*PMRE41	0.8	PMRE41SA
1-1/4" - 3/4"	*PMRE42	0.8	PMRE42SA
1-1/4" - 1"	*PMRE43	0.8	PMRE43SA
1-1/2" - 1/2"	*PMRE51	0.9	PMRE51SA
1-1/2" - 3/4"	*PMRE52	0.9	PMRE52SA
1-1/2" - 1"	*PMRE53	0.9	PMRE53SA
1-1/2" - 1-1/4"	*PMRE54	0.9	PMRE54SA
2" - 1/2"	*PMRE61	1.1	PMRE61SA
2" - 3/4"	*PMRE62	1.1	PMRE62SA
2" - 1"	*PMRE63	1.2	PMRE63SA
2" - 1-1/4"	*PMRE64	1.3	PMRE64SA
2" - 1-1/2"	*PMRE65	1.6	PMRE65SA
2-1/2" - 1"	*PMRE73	1.6	PMRE73SA
2-1/2" - 1-1/4"	*PMRE74	1.6	PMRE74SA

PIPE SIZE	FERROUS CATALOG #	NOMINAL WEIGHT	ALUMINUM CATALOG #
2-1/2" - 1-1/2"	*PMRE75	1.6	PMRE75SA
2-1/2" - 2"	*PMRE76	1.7	PMRE76SA
3" - 1"	*PMRE83	1.7	PMRE83SA
3" - 1-1/4"	*PMRE84	2.3	PMRE84SA
3" - 1-1/2"	*PMRE85	2.4	PMRE85SA
3" - 2"	*PMRE86	2.5	PMRE86SA
3" - 2-1/2"	*PMRE87	4.0	PMRE87SA
3-1/2" - 2"	*PMRE96	4.6	PMRE96SA
3-1/2" - 2-1/2"	*PMRE97	4.7	PMRE97SA
3-1/2" - 3"	*PMRE98	4.8	PMRE98SA
4" - 2"	*PMRE106	5.0	PMRE106SA
4" - 2-1/2"	*PMRE107	5.2	PMRE107SA
4" - 3"	*PMRE108	6.0	PMRE108SA
4" - 3-1/2"	*PMRE109	6.1	PMRE109SA
5" - 4"	PMRE01210	7.4	PMRE01210SA
6" - 5"	PMRE01412	8.0	PMRE01412SA



DESCRIPTION

Perma-Cote reducing couplings are used to connect two pieces of conduit of different sizes.

STANDARDS

- NEC/CEC:
 - Class I, Division 1 & 2, Groups A, B, C, D
 - Class II, Division 1, Groups E, F, G
 - Class II, Division 2, Groups F, G
 - Class III
 - *Class I, Division 2 Group A & B
 - +Class I, Division 1 & 2, Group B

NOTE: REs and PLGs meet the above standards only when used in conjunction with hazardous location fittings.

PIPE SIZE	FERROUS CATALOG #	NOMINAL WEIGHT	ALUMINUM CATALOG #
3/4" - 1/2"	*PMREC-0705	0.2	PMREC-0705-A
1" - 1/2"	*PMREC-1005	0.7	PMREC-1005-A
1" - 3/4"	PMREC-1007	0.5	PMREC-1007-A
1-1/4" - 3/4"	PMREC-1207	1.0	PMREC-1207-A
1-1/4" - 1"	PMREC-1210	0.8	PMREC-1210-A
1-1/2" - 3/4"	PMREC-1507	1.4	PMREC-1507-A
1-1/2" - 1"	PMREC-1510	1.2	PMREC-1510-A
1-1/2" - 1-1/4"	PMREC-1512	1.3	PMREC-1512-A
2" - 3/4"	PMREC-2007	1.5	PMREC-2007-A
2" - 1"	PMREC-2010	2.3	PMREC-2010-A
2" - 1-1/4"	PMREC-2012	2.6	PMREC-2012-A
2" - 1-1/2"	PMREC-2015	2.8	PMREC-2015-A
2-1/2" - 1-1/2"	PMREC-2515	3.2	-
3" - 2"	PMREC-3020	3.7	PMREC-3020-A
3-1/2" - 2-1/2"	PMREC-97	4.6	-
4" - 3"	PMREC-4030	5.9	-
5" - 4"	PMREC-5040	7.4	-

DESCRIPTION

PLG style plugs are used to close unused conduit hubs. They are available with either recessed square drive sockets or raised square drive heads. **All PLG plugs are coated with a polyester urethane powder for corrosion protection.**

SQUARE HEAD PLUGS

PIPE SIZE	FERROUS CATALOG #	NOMINAL WEIGHT
1/2"	*PMPLG15	0.5
3/4"	*PMPLG25	0.6
1"	*PMPLG35	0.2
1-1/4"	†PMPLG45	0.3
1-1/2"	†PMPLG55	0.3
2"	†PMPLG65	0.4
2-1/2"	PMPLG75	0.4
3"	PMPLG85	0.5
3-1/2"	PMPLG95	0.5
4"	PMPLG105	0.6

RECESSED PLUGS

PIPE SIZE	FERROUS CATALOG #	NOMINAL WEIGHT
1/2"	*PMPLG1	0.2
3/4"	*PMPLG2	0.2
1"	*PMPLG3	0.3
1-1/4"	†PMPLG4	0.3
1-1/2"	†PMPLG5	0.3
2"	†PMPLG6	0.3
2-1/2"	†PMPLG7	0.3
3"	†PMPLG8	0.4
3-1/2"	†PMPLG9	0.4
4"	†PMPLG10	0.5

Conduit Expansion Joints

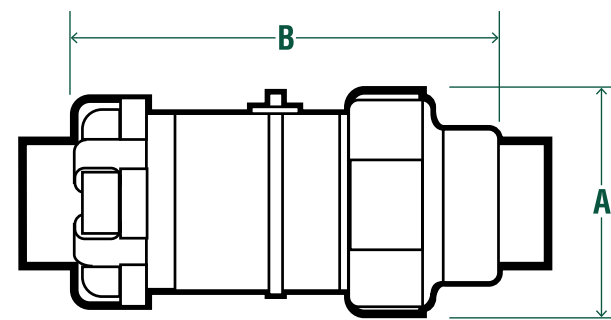

4" TRAVEL AX SERIES

PIPE SIZE	FERROUS CATALOG #	A	B	NOMINAL WEIGHT	ALUMINUM CATALOG #
1/2"	PMAX50	1.83	6.75	1.5	PMAX50-A
3/4"	PMAX75	2.20	6.75	2.9	PMAX75-A
1"	PMAX100	2.51	7.25	3.6	PMAX100-A
1-1/4"	PMAX125	3.27	7.56	3.8	PMAX125-A
1-1/2"	PMAX150	3.76	7.87	6.2	PMAX150-A
2"	PMAX200	4.83	8.25	7.3	PMAX200-A
2-1/2"	PMAX250	4.95	9.31	9.8	-
3"	PMAX300	5.45	10.00	13.6	PMAX300-A
3-1/2"	PMAX350	6.70	9.81	16.1	PMAX350-A
4"	PMAX400	6.70	9.81	22.5	PMAX400-A

8" TRAVEL AX SERIES

PIPE SIZE	FERROUS CATALOG #	A	B	NOMINAL WEIGHT	ALUMINUM CATALOG #
1/2"	PMAX850	1.83	10.75	1.9	PMAX850-A
3/4"	PMAX875	2.20	10.75	3.0	PMAX875-A
1"	PMAX8100	2.51	11.25	3.3	PMAX8100-A
1-1/4"	PMAX8125	3.27	11.56	4.7	PMAX8125-A
1-1/2"	PMAX8150	3.76	11.87	7.3	PMAX8150-A
2"	PMAX8200	4.83	12.25	10.7	PMAX8200-A
2-1/2"	PMAX8250	4.95	13.31	14.4	PMAX8250-A
3"	PMAX8300	5.45	14.00	15.9	PMAX8300-A
3-1/2"	PMAX8350	6.70	13.81	23.8	PMAX8350-A
4"	PMAX8400	6.70	13.81	25.7	PMAX8400-A



INSTALLATION TIP!

Ensure you pull the body away from the conduit so that the locking feature disengages. This will allow for telescoping movement in either direction.

DESCRIPTION

Perma-Cote XJG type expansion joints are used to connect two lengths of conduit subject to longitudinal movement, including movement in long runs by thermal expansion and contraction.

FEATURES

- 40 mil gray PVC exterior coating
- 2 mil green urethane interior coating
- 10 trade sizes from 1/2" through 4"
- Sealing sleeves on all female conduit openings
- Available with either 4" or 8" maximum movement
- Internally grounded

STANDARDS

- NEC Article 250-77
- NEC Article 300-7 (b)
- NEMA FBI

Service Entrance Elbows



DESCRIPTION

Perma-Cote LBY type elbows are used as service entrance elbows between service entrance and vertical weatherhead conduit runs, to change direction of a conduit run 90° when space is limited, and for pull outlets. They may be used for general service or hazardous locations.

FEATURES

- 40 mil gray PVC exterior coating
- 2 mil green urethane interior coating
- 5 trade sizes from 1/2" through 1 1/2"
- Sealing sleeves on all female conduit openings
- Molded PVC gasket seals fitting cover to body

STANDARDS

- NEC/CEC
 - Class I, Division 1 & 2, Groups C, D
 - Class II, Division 1, Groups E, F, G
 - Class II, Division 2, Groups F, G
 - Class III

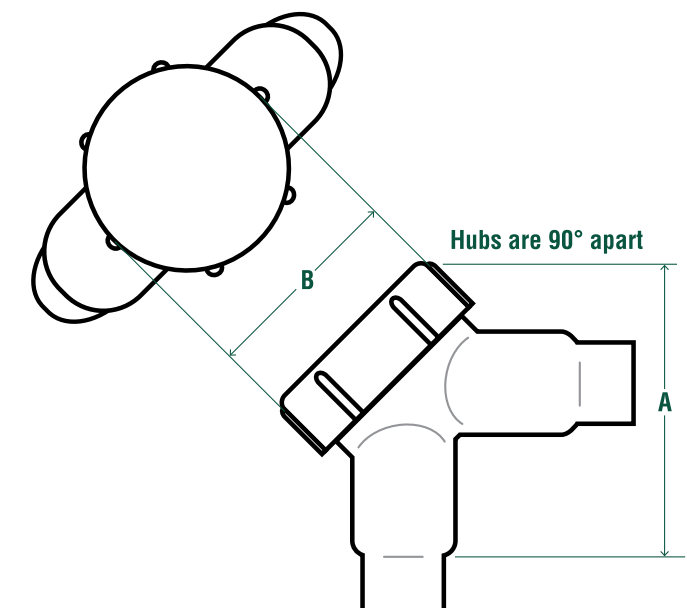

LBY SERIES

FOR HAZARDOUS LOCATIONS

PIPE SIZE	FERROUS CATALOG #	A	B	NOMINAL WEIGHT	ALUMINUM CATALOG #
1/2"	PMLBY-50	2.81	2.08	1.0	PMLBY-50-A
3/4"	PMLBY-75	3.19	2.33	1.2	PMLBY-75-A
1"	PMLBY-100	3.25	2.58	1.7	PMLBY-100-A
1-1/4"	PMLBY-125	3.78	3.02	2.5	PMLBY-125-A
1-1/2"	PMLBY-150	4.50	3.46	2.7	PMLBY-150-A

Malleable Elbows

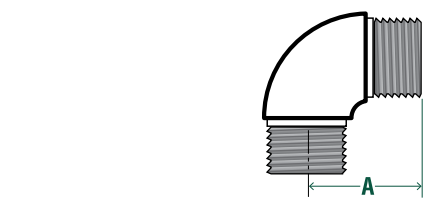

90° MALE-MALE

PIPE SIZE	FERROUS CATALOG #	A	NOMINAL WEIGHT
1/2"	PMEL-195	1.44	0.3
3/4"	PMEL-295	1.63	0.5
1"	PMEL-395	1.88	0.7

DESCRIPTION

Perma-Cote EL style malleable elbows are used in a conduit run to change direction 90° or to terminate at a fitting or box. They are available with male threads only, female threads only, or male and female threads.

FEATURES

- 40 mil gray PVC exterior coating
- 2 mil green urethane interior coating
- Various configurations in 10 trade sizes from 1/2" through 2 1/2"
- Sealing sleeves on all female conduit openings

STANDARDS

- Sizes 1/2" through 1":
NEC/CEC
Class I, Division 1 & 2, Groups A, B, C, D
Class II, Division 1, Groups E, F, G
Class II, Division 2, Groups F, G
Class III
- Sizes 1 1/4" through 2 1/2":
NEC/CEC
Class I, Division 1 & 2, Groups C, D
Class II, Division 1, Groups E, F, G
Class II, Division 2, Groups F, G
Class III

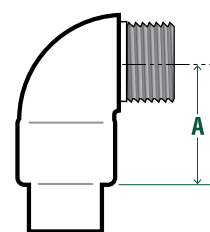

90° MALE-FEMALE

PIPE SIZE	FERROUS CATALOG #	A	NOMINAL WEIGHT	ALUMINUM CATALOG #
1/2"	PM8-50	1.53	0.3	PM8-50-A
3/4"	PM8-75	1.63	0.5	PM8-75-A
1"	PM8-100	1.88	1.2	PM8-100-A
1-1/4"	PM8-125	2.13	2.8	-

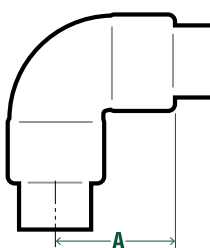

90° FEMALE-FEMALE

PIPE SIZE	FERROUS CATALOG #	A	NOMINAL WEIGHT	ALUMINUM CATALOG #
1/2"	PMEL-950	1.53	0.7	PMEL-950-A
3/4"	PMEL-975	1.75	0.9	PMEL-975-A
1"	PMEL-9100	2.00	1.2	PMEL-9100-A
1-1/4"	PMEL-9125	2.25	2.4	PMEL-9125-A
1-1/2"	PMEL-9150	4.00	3.0	PMEL-9150-A
2"	PMEL-9200	5.00	6.0	PMEL-9200-A
2-1/2"	PMEL-9250	6.44	7.9	-

Conduit Unions



DESCRIPTION

Perma-Cote UNF unions are used to connect conduit to conduit and to allow for future changes to the conduit system. Female threads are provided at each end. Perma-Cote UNY unions are used to connect conduit to a conduit fitting, junction box, or device enclosure. One end is a male thread and the other is female.

FEATURES

- 40 mil gray PVC exterior coating
- 2 mil green urethane interior coating
- 13 trade sizes from 1/2" through 6"
- Sealing sleeves on all female conduit openings
- Molded PVC gasket seals fitting

UNF

PIPE SIZE	FERROUS CATALOG #	NOMINAL WEIGHT	LENGTH	MAX DIA.	ALUMINUM CATALOG #
1/2"	PMUNF50	0.3	1.81	2.00	PMUNF50-A
3/4"	PMUNF75	0.5	1.75	2.25	PMUNF75-A
3/4" - 1/2"	PMUNF75-50	0.6	1.75	2.25	-
1"	PMUNF100	0.7	2.00	2.75	PMUNF100-A
1-1/4"	PMUNF125	1.5	2.25	3.00	PMUNF125-A
1-1/2"	PMUNF150	2.3	2.63	3.50	PMUNF150-A
2"	PMUNF200	3.6	2.56	4.50	PMUNF200-A
2-1/2"	PMUNF250	5.0	3.19	4.75	PMUNF250-A
3"	PMUNF300	6.5	3.44	5.50	PMUNF300-A
3-1/2"	PMUNF350	8.2	4.13	6.50	PMUNF350-A
4"	PMUNF400	10.0	4.13	7.00	PMUNF400-A
5"	PMUNF500	12.5	3.81	9.00	-
6"	PMUNF600	14.8	3.81	10.25	-

STANDARDS

UL 1203 (E476062)

- NEC/CEC
- CSA C22.2 NO.30

UNF/UNY 1/2" through 1"

- Class I, Division 1 & 2, Groups A, B, C, D
- Class II, Division 1, Groups E, F, G
- Class II, Division 2, Groups F, G
- Class III

UNF/UNY 1 1/2" through 4"

- Class I, Division 1 & 2, Groups B, C, D
- Class II, Division 1, Groups E, F, G
- Class II, Division 2, Groups F, G
- Class III

Aluminum - All Sizes

- Class I, Division 1 & 2, Groups C, D
- Class II, Division 1, Groups E, F, G
- Class II, Division 2, Groups F, G
- Class III

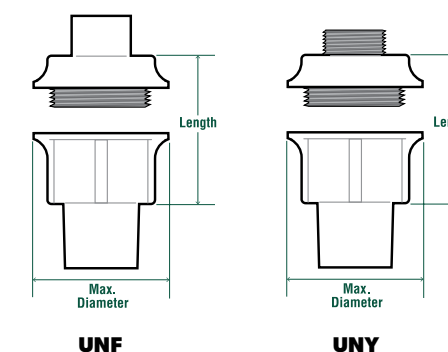

UNY

PIPE SIZE	FERROUS CATALOG #	NOMINAL WEIGHT	LENGTH	MAX DIA.	ALUMINUM CATALOG #
1/2"	PMUNY50	0.4	2.38	2.00	PMUNY50-A
3/4"	PMUNY75	0.7	2.44	2.25	PMUNY75-A
3/4" - 1/2"	PMUNY75-50	0.8	2.44	2.25	-
1"	PMUNY100	1.3	2.75	2.75	PMUNY100-A
1-1/4"	PMUNY125	2.6	3.19	3.00	PMUNY125-A
1-1/2"	PMUNY150	3.9	3.56	3.50	PMUNY150-A
2"	PMUNY200	4.2	3.75	4.50	PMUNY200-A
2-1/2"	PMUNY250	5.5	4.63	4.75	PMUNY250-A
3"	PMUNY300	7.5	5.00	5.50	PMUNY300-A
3-1/2"	PMUNY350	8.4	5.50	6.50	PMUNY350-A
4"	PMUNY400	10.5	5.63	7.00	PMUNY400-A
5"	PMUNY500	12.0	5.25	9.00	-
6"	PMUNY600	14.9	5.38	10.25	-



GUA Series Outlet Boxes



DESCRIPTION

Perma-Cote GUA series conduit outlet boxes are installed in hazardous location conduit systems to serve as pull-and-splice boxes, to change the direction of a conduit run, to connect runs of conduit, or to provide access to conductors. They are provided with covers as standard. Inquire about special covers to use as mounts for light fixtures or as sealing fittings. Electrical continuity of the conduit system is maintained across assembled joints.

FEATURES

- 40 mil gray PVC exterior coating
- 2 mil green urethane interior coating
- Trade sizes from 1/2" through 2" in various styles and configurations
- Sealing sleeves on all female conduit openings
- Neoprene O-ring is standard
- Molded-in PVC seal preserves venting characteristics of fitting, but seals out corrosives
- Standard material is a cast iron alloy body with a copper-free aluminum cover. Consult factory for availability of cast iron covers
- Internal green grounding screw is standard

STANDARDS

UL 1203 (E495357)

- NEC/CEC
- CSA C22.2 NO.30

Steel and Aluminum

- UL 514A, 514D (E231035)
- CSA C22.2 No. 18, CSA C22.2 No. 42

NEC/CEC

- Class I, Division 1 & 2, Groups C, D
- Class II, Division 1, Groups E, F, G
- Class II, Division 2, Groups F, G
- Class III

ANSI Standard C-33.27

NEMA/EEMAC 3,4

**When ordered with suffix -SA are listed for Class I, Division 1 & 2, Groups B, C and D, Class II, Division 1, Groups E, F, G and Class III. Covers have 16 pitch threads. Replacement cover is a GUA06-GB.*

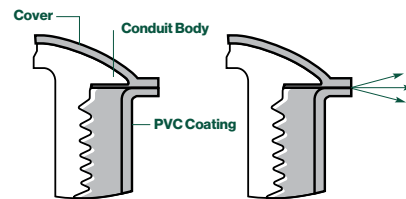

An integral PVC gasket on GUA type fittings preserves the venting characteristics of the uncoated fitting, but prevents corrosive liquids from entering from the outside.

Variables referenced to the technical data charts.

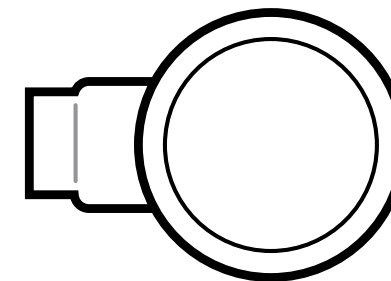
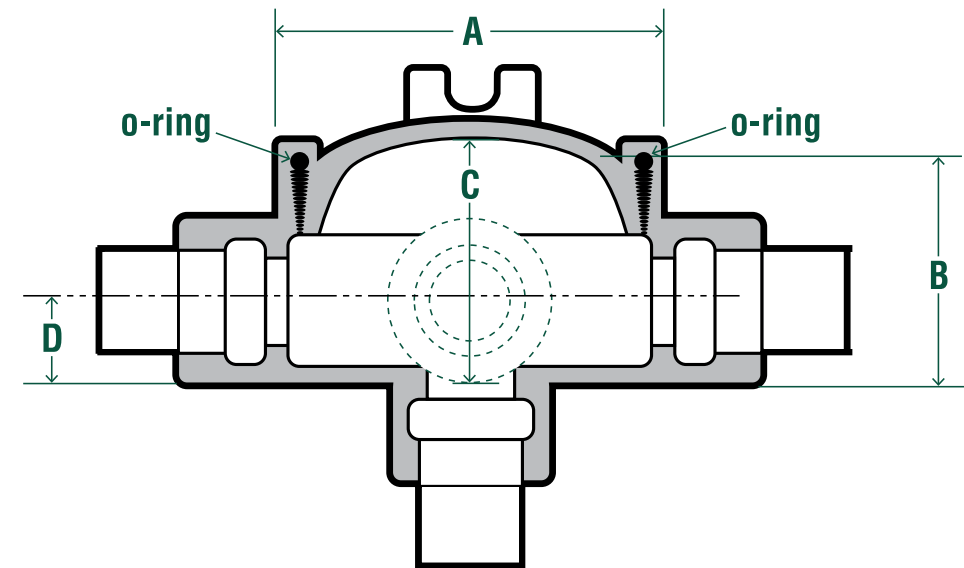

GUA

PIPE SIZE	FERROUS CATALOG #	COVER OPENING	ALUMINUM CATALOG #	PRODUCT DIMENSIONS			
				A	B	C	D
1/2"	PMGUA14	2"	-	2.58	1.85	1.75	0.67
1/2"	PMGUA16	3"	-	3.58	2.04	1.88	0.67
3/4"	PMGUA24	2"	-	2.58	2.04	2.00	0.79
3/4"	PMGUA26	3"	PMGUA-26-A	3.58	2.04	1.88	0.79
1"	PMGUA36	3"	-	3.58	2.35	2.19	0.92
1-1/4"	PMGUA47	3-5/8"	-	4.33	2.73	2.75	1.13
1-1/2"	PMGUA59	5"	-	5.83	3.85	3.75	1.32

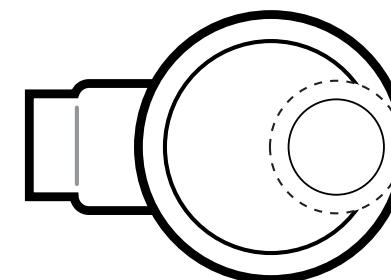

GUAB

PIPE SIZE	FERROUS CATALOG #	COVER OPENING	NOMINAL WEIGHT	ALUMINUM CATALOG #	PRODUCT DIMENSIONS			
					A	B	C	D
1/2"	PMGUA14	2"	2.0	PMGUA14-A	2.58	2.29	2.19	0.67
1/2"	PMGUALB50	3"	3.2	PMGUALB50-A	3.58	2.04	1.88	0.67
3/4"	PMGUALB24	2"	2.2	-	2.58	2.54	2.44	0.79
3/4"	PMGUALB75	3"	3.3	PMGUALB75-A	3.58	2.04	1.88	0.79
1"	PMGUALB100	3"	3.8	PMGUALB100-A	3.58	2.35	2.19	0.92
1-1/4"	PMGUALB125	3-5/8"	5.0	PMGUALB125-A	4.33	2.73	2.75	1.13
1-1/2"	PMGUALB150	5"	8.1	PMGUALB150-A	5.83	3.85	3.75	1.32
2"	PMGUALB200	5"	9.1	PMGUALB200-A	5.83	4.10	4.00	1.60

GUA Series Outlet Boxes

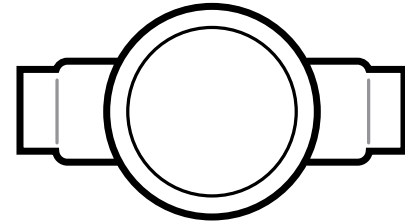

GUAC

PIPE SIZE	FERROUS CATALOG #	COVER OPENING	NOMINAL WEIGHT	ALUMINUM CATALOG #	PRODUCT DIMENSIONS			
					A	B	C	D
1/2"	PMGUAC14	2"	3.5	PMGUAC14-A	2.58	2.29	2.19	0.67
1/2"	PMGUAC50	3"	2.0	PMGUAC50-A	3.58	2.04	1.88	0.67
3/4"	PMGUAC24	2"	3.5	PMGUAC24-A	2.58	2.04	2.00	0.79
3/4"	PMGUAC75	3"	2.0	PMGUAC75-A	3.58	2.04	1.88	0.79
1"	PMGUAC100	3"	3.9	PMGUAC100-A	3.58	2.35	2.19	0.92
1-1/4"	PMGUAC125	3-5/8"	5.2	PMGUAC125-A	4.33	2.73	2.75	1.13
1-1/4"	PMGUAC49	5"	9.5	-	5.83	3.85	3.75	1.20
1-1/2"	PMGUAC150	5"	11.0	PMGUAC150-A	5.83	3.85	3.75	1.32
2"	PMGUAC200	5"	11.0	PMGUAC200-A	5.83	4.10	4.00	1.60

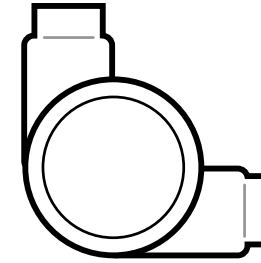

GUAN

PIPE SIZE	FERROUS CATALOG #	COVER OPENING	NOMINAL WEIGHT	ALUMINUM CATALOG #	PRODUCT DIMENSIONS			
					A	B	C	D
1/2"	PMGUANI4	2"	2.0	-	2.58	2.17	2.06	0.67
1/2"	PMGUANI6	3"	3.8	-	3.58	2.04	1.88	0.67
3/4"	PMGUAN24	2"	2.5	-	2.58	2.35	2.25	0.79
3/4"	PMGUAN26	3"	3.5	-	3.58	2.04	1.88	0.79
1"	PMGUAN36	3"	3.0	-	3.58	2.35	2.38	0.92
1-1/4"	PMGUAN47	3-5/8"	5.2	-	4.33	2.73	2.75	1.13
1-1/2"	PMGUAN59	5"	9.5	-	5.83	4.10	4.00	1.32
2"	PMGUAN69	5"	12.0	-	5.83	4.10	4.00	1.60

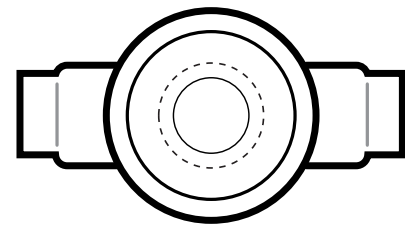

GUAD

PIPE SIZE	FERROUS CATALOG #	COVER OPENING	NOMINAL WEIGHT	ALUMINUM CATALOG #	PRODUCT DIMENSIONS			
					A	B	C	D
1/2"	PMGUAD14	2"	2.0	-	2.58	1.85	1.75	0.67
1/2"	PMGUAD16	3"	3.2	-	3.58	2.04	1.88	0.67
3/4"	PMGUAD24	2"	3.5	-	2.58	2.04	2.00	0.79
3/4"	PMGUAD26	3"	3.8	PMGUAD26-A	3.58	2.04	1.88	0.79
1"	PMGUAD36	3"	3.8	PMGUAD36-A	3.58	2.35	2.19	0.92
1-1/4"	PMGUAD49	5"	10.9	-	5.83	3.85	3.75	1.13

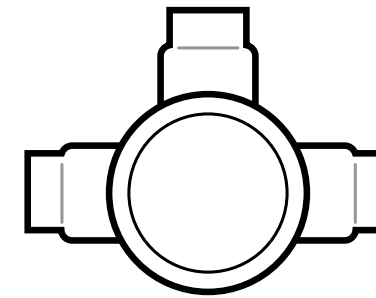

GUAT

PIPE SIZE	FERROUS CATALOG #	COVER OPENING	NOMINAL WEIGHT	ALUMINUM CATALOG #	PRODUCT DIMENSIONS			
					A	B	C	D
1/2"	PMGUAT14	2"	2.0	PMGUAT14-A	2.58	2.29	2.19	0.67
1/2"	PMGUAT50	3"	2.8	PMGUAT50-A	3.58	2.04	1.88	0.67
3/4"	PMGUAT24	2"	2.2	PMGUAT24-A	2.58	2.04	2.00	0.79
3/4"	PMGUAT75	3"	3.5	PMGUAT75-A	3.58	2.04	1.88	0.79
1"	PMGUAT100	3"	3.2	PMGUAT100-A	3.58	2.35	2.19	0.92
1-1/4"	PMGUAT125	3-5/8"	5.7	PMGUAT125-A	4.33	2.73	2.75	1.13
1-1/2"	PMGUAT150	5"	9.1	PMGUAT150-A	5.83	3.85	3.75	1.32
2"	PMGUAT200	5"	10.0	PMGUAT200-A	5.83	4.10	4.00	1.60

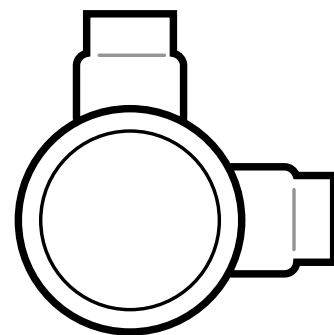

GUAL

PIPE SIZE	FERROUS CATALOG #	COVER OPENING	NOMINAL WEIGHT	ALUMINUM CATALOG #	PRODUCT DIMENSIONS			
					A	B	C	D
1/2"	PMGUAL14	2"	2.0	PMGUAL14-A	2.58	1.85	1.75	0.67
1/2"	PMGUAL50	3"	2.1	PMGUAL50-A	3.58	2.04	1.88	0.67
3/4"	PMGUAL24	2"	3.2	PMGUAL24-A	2.58	2.04	2.00	0.79
3/4"	PMGUAL75	3"	2.5	PMGUAL75-A	3.58	2.04	1.88	0.79
1"	PMGUAL100	3"	3.7	PMGUAL100-A	3.58	2.35	2.19	0.92
1-1/4"	PMGUAL125	3-5/8"	5.2	PMGUAL125-A	4.33	2.73	2.75	1.13
1-1/4"	PMGUAL49	5"	8.5	PMGUAL49-A	5.83	3.85	3.75	1.20
1-1/2"	PMGUAL150	5"	11.2	PMGUAL150-A	5.83	3.85	3.75	1.32
2"	PMGUAL200	5"	12.5	PMGUAL200-A	5.83	4.10	4.00	1.60

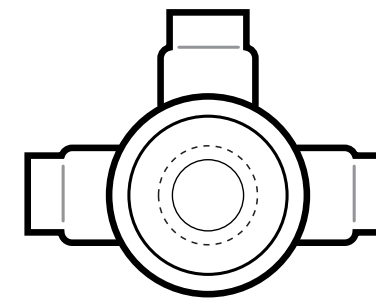

GUAW

PIPE SIZE	FERROUS CATALOG #	COVER OPENING	NOMINAL WEIGHT	ALUMINUM CATALOG #	PRODUCT DIMENSIONS			
					A	B	C	D
1/2"	PMGUAW14	2"	2.0	-	2.58	1.85	1.75	0.67
1/2"	PMGUAW16	3"	2.0	-	3.58	2.04	1.88	0.67
3/4"	PMGUAW24	2"	3.0	-	2.58	2.04	2.00	0.79
3/4"	PMGUAW26	3"	3.0	PMGUAW26-A	3.58	2.04	1.88	0.79

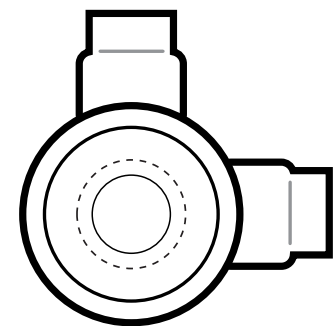

GUAM

PIPE SIZE	FERROUS CATALOG #	COVER OPENING	NOMINAL WEIGHT	ALUMINUM CATALOG #	PRODUCT DIMENSIONS			
					A	B	C	D
1/2"	PMGUAM14	2"	2.0	PMGUAM14-A	2.58	1.85	1.75	0.67
1/2"	PMGUAM24	3"	3.2	-	3.58	2.04	1.88	0.67
3/4"	PMGUAM16	2"	2.2	-	2.58	2.04	2.00	0.79
3/4"	PMGUAM26	3"	3.3	-	3.58	2.04	1.88	0.79
1"	PMGUAM36	3"	3.8	-	3.58	2.35	2.19	0.92
1-1/4"	PMGUAM47	3-5/8"	5.0	-	4.33	2.73	2.75	1.13
2"	PMGUAM69	5"	9.1	-	5.83	4.10	4.00	1.60

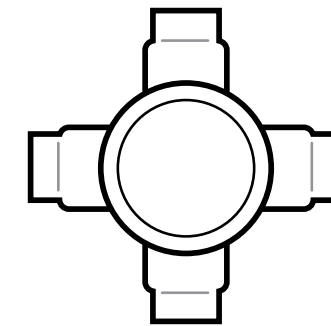

GUAX

PIPE SIZE	FERROUS CATALOG #	COVER OPENING	NOMINAL WEIGHT	ALUMINUM CATALOG #	PRODUCT DIMENSIONS			
					A	B	C	D
1/2"	PMGUAX14	2"	2.0	-	2.58	1.85	1.75	0.67
1/2"	PMGUAX50	3"	3.8	PMGUAX50-A	3.58	2.04	1.88	0.67
3/4"	PMGUAX24	2"	2.5	PMGUAX24-A	2.58	2.04	2.00	0.79
3/4"	PMGUAX75	3"	2.8	PMGUAX75-A	3.58	2.04	1.88	0.79
1"	PMGUAX100	3"	4.2	PMGUAX100-A	3.58	2.35	2.19	0.92
1-1/4"	PMGUAX125	3-5/8"	4.8	PMGUAX125-A	4.33	2.73	2.75	1.13
1-1/2"	PMGUAX150	5"	11.7	PMGUAX150-A	5.83	3.85	3.75	1.32
2"	PMGUAX200	5"	12.5	PMGUAX200-A	5.83	4.10	4.00	1.60

Sealing Fittings



FEATURING THE
P5SA™
INNOVATION

DESCRIPTION

Perma-Cote Sealing Fittings are used in conduit runs to stop gasses, vapors or flames from migrating from one part of the conduit system to another. This limits the spread of any potential explosion, enhancing safety. The PVC and urethane coatings of the fittings protects them from corrosive atmospheres so they can continue to function in hazardous locations. These fittings are available in several different configurations and with optional breathers and drains to accommodate installation in a variety of locations and positions. The EYD, EYDM, EYDEF and EZD styles of fittings are for installation in vertical conduit runs. The EYA, EYS, EYAM and EYSEF style fittings are for installation in either vertical or horizontal runs. The EZS and EYDM style fitting may be used in any angle of conduit run.



INSTALLATION TIP!

To make sure you have proper plug engagement, the plug should be below the beveled edge of the PVC.

FEATURES

- 40 mil gray PVC exterior coating
- 2 mil green urethane interior coating
- 10 trade sizes from ½” through 4”
- Sealing sleeves on all conduit openings
- EYDEF and EYSEF seals have 40% wire fill capacity
- EYD, EYDM and EZD fittings include a drain for condensate
- EZD fittings may be used at any conduit angle and include drain
- P5SA™ Plug Verification System

STANDARDS

UL 1203 (E476062)

- NEC/CEC
- CSA C22.2 NO.30

EY 50-100, EYA 50-100, EYM 50-100, EYAM 50-100

- Class I, Division 1 & 2, Groups A, B, C, D
- Class II, Division 1, Groups E, F, G
- Class II, Division 2, Groups F, G
- Class III

EYS 41-61, EYSEF 50-300, EYDEF 50-300

- Class I, Division 1 & 2, Groups B, C, D
- Class II, Division 1, Groups E, F, G
- Class II, Division 2, Groups F, G
- Class III

EYA 125-400, EYAM 125-400, EZS 50-300, EZDM 50-300, EYD 50-400, EYDM 50-400, EZD 50-200

- Class I, Division 1 & 2, Groups C, D
- Class II, Division 1, Groups F, G
- Class II, Division 2, Groups F, G
- Class III

EYSEF 350-400

- Class I, Division 1 & 2, Groups C, D
- Class II, Division 1, Groups E, F, G
- Class II, Division 2, Groups F, G
- Class III

These Perma-Cote sealing fittings should be used with a suitable system of sealing compound, such as Chico A, Chico X, or Chico A-P from Crouse-Hinds. Chico® SpeedSeal™ may be used on EYS or EYD sizes ½” through 2”. Follow the installation instructions included with the sealing compound and properly tag after installation to ensure correct classification ratings.

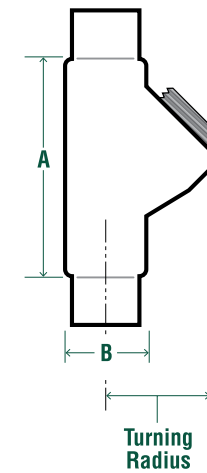

EY - FEMALE HUBS

FOR SEALING IN VERTICAL POSITIONS ONLY

PIPE SIZE	FERROUS CATALOG #	NOMINAL WEIGHT	A	B	TURNING RADIUS	ALUMINUM CATALOG #
1/2"	PMEY-50	1.0	3.28	1.33	1.63	PMEY-50-A
3/4"	PMEY-75	1.5	3.75	1.58	1.91	PMEY-75-A
1"	PMEY-100	2.1	4.31	1.83	2.38	PMEY-100-A

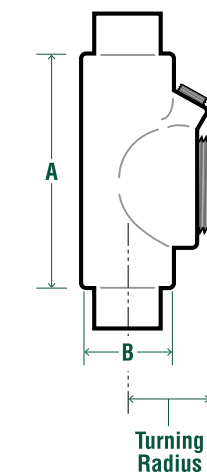

EYA - FEMALE HUBS

FOR SEALING IN VERTICAL OR HORIZONTAL POSITIONS

PIPE SIZE	FERROUS CATALOG #	NOMINAL WEIGHT	A	B	TURNING RADIUS	ALUMINUM CATALOG #
1-1/4"	PMEYA-125	2.7	5.06	2.27	1.72	PMEYA-125-A
1-1/2"	PMEYA-150	3.7	5.50	2.52	2.06	PMEYA-150-A
2"	PMEYA-200	4.7	6.25	3.08	2.31	PMEYA-200-A
2-1/2"	PMEYA-250	10.0	7.50	3.58	2.69	PMEYA-250-A
3"	PMEYA-300	11.2	8.50	4.33	3.31	PMEYA-300-A
3-1/2"	PMEYA-350	14.5	9.19	4.83	3.44	PMEYA-350-A
4"	PMEYA-400	16.0	9.75	5.33	3.69	PMEYA-400-A

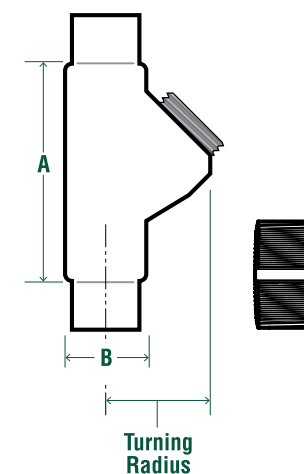

EYM - MALE/FEMALE HUBS

FOR SEALING IN VERTICAL POSITIONS ONLY

PIPE SIZE	FERROUS CATALOG #	NOMINAL WEIGHT	A	B	TURNING RADIUS	ALUMINUM CATALOG #
1/2"	PMEYM-50	1.5	3.28	1.33	1.63	PMEYM-50-A
3/4"	PMEYM-75	1.5	3.75	1.58	1.91	PMEYM-75-A
1"	PMEYM-100	2.3	4.31	1.83	2.38	PMEYM-100-A

Sealing Fittings

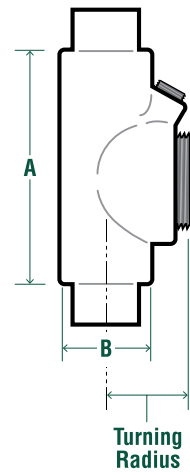

EYA - FEMALE HUBS FOR SEALING IN VERTICAL OR HORIZONTAL POSITIONS

PIPE SIZE	FERROUS CATALOG #	NOMINAL WEIGHT	A	B	TURNING RADIUS	ALUMINUM CATALOG #
1/2"	PMEYA-50	1.3	3.69	1.33	1.16	PMEYA-50-A
3/4"	PMEYA-75	1.1	3.69	1.58	1.25	PMEYA-75-A
1"	PMEYA-100	2.2	4.31	1.83	1.38	PMEYA-100-A

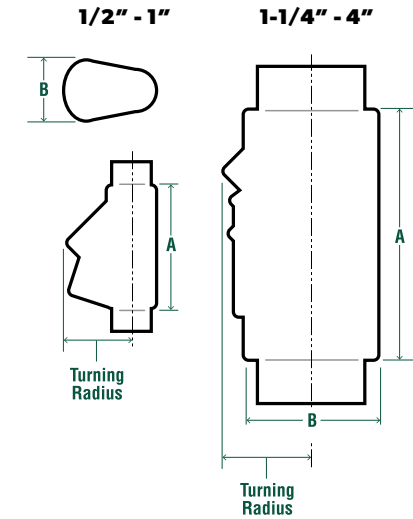

EYD - FEMALE HUBS WITH DRAIN FOR SEALING IN VERTICAL POSITIONS ONLY

PIPE SIZE	FERROUS CATALOG #	NOMINAL WEIGHT	A	B	TURNING RADIUS	ALUMINUM CATALOG #
1/2"	PMEYD-50	1.4	3.28	1.33	1.63	PMEYD-50-A
3/4"	PMEYD-75	1.7	3.69	1.58	1.91	PMEYD-75-A
1"	PMEYD-100	2.3	4.31	2.27	2.38	PMEYD-100-A
1-1/4"	PMEYD-125	2.5	5.06	2.27	1.84	PMEYD-125-A
1-1/2"	PMEYD-150	4.0	5.50	2.52	2.06	PMEYD-150-A
2"	PMEYD-200	4.7	6.25	3.08	2.31	PMEYD-200-A
2-1/2"	PMEYD-250	9.0	7.50	3.58	2.69	PMEYD-250-A
3"	PMEYD-300	10.2	8.50	4.33	3.31	PMEYD-300-A
3-1/2"	PMEYD-350	10.5	9.19	4.83	3.44	PMEYD-350-A
4"	PMEYD-400	4.0	9.75	5.33	3.50	PMEYD-400-A

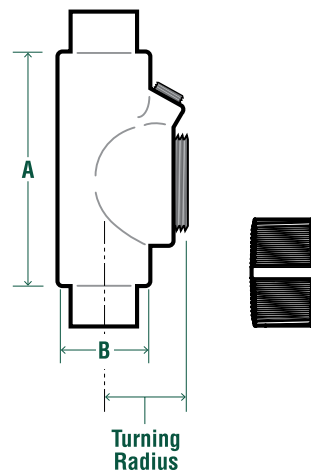

EYAM - MALE/FEMALE HUBS FOR SEALING IN VERTICAL OR HORIZONTAL POSITIONS

PIPE SIZE	FERROUS CATALOG #	NOMINAL WEIGHT	A	B	TURNING RADIUS	ALUMINUM CATALOG #
1/2"	PMEYAM-50	1.5	3.69	1.33	1.16	PMEYAM-50-A
3/4"	PMEYAM-75	1.2	3.69	1.58	1.25	PMEYAM-75-A
1"	PMEYAM-100	2.6	4.31	1.83	1.38	PMEYAM-100-A
1-1/4"	PMEYAM-125	2.8	5.06	2.27	1.72	PMEYAM-125-A
1-1/2"	PMEYAM-150	3.7	5.50	2.52	2.06	PMEYAM-150-A
2"	PMEYAM-200	5.6	6.25	3.08	2.31	PMEYAM-200-A
2-1/2"	PMEYAM-250	13.2	7.50	3.58	2.69	PMEYAM-250-A
3"	PMEYAM-300	11.2	8.50	4.33	3.31	PMEYAM-300-A
3-1/2"	PMEYAM-350	14.5	9.19	4.83	3.44	PMEYAM-350-A
4"	PMEYAM-400	1.5	9.75	5.33	3.69	PMEYAM-400-A

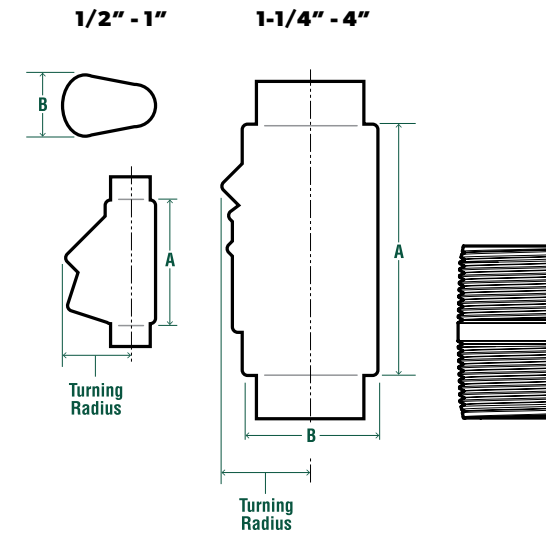

EYDM - MALE/FEMALE HUBS WITH DRAIN FOR SEALING IN VERTICAL POSITIONS ONLY

PIPE SIZE	FERROUS CATALOG #	NOMINAL WEIGHT	A	B	TURNING RADIUS	ALUMINUM CATALOG #
1/2"	PMEYDM-50	2.7	3.28	1.33	1.63	PMEYDM-50-A
3/4"	PMEYDM-75	2.8	3.69	1.58	1.91	PMEYDM-75-A
1"	PMEYDM-100	2.9	4.31	2.27	2.38	PMEYDM-100-A
1-1/4"	PMEYDM-125	2.6	5.06	2.27	1.84	PMEYDM-125-A
1-1/2"	PMEYDM-150	3.7	5.50	2.52	2.06	PMEYDM-150-A
2"	PMEYDM-200	5.2	6.25	3.08	2.31	PMEYDM-200-A
2-1/2"	PMEYDM-250	9.5	7.50	3.58	2.69	PMEYDM-250-A
3"	PMEYDM-300	11.3	8.50	4.33	3.31	PMEYDM-300-A
3-1/2"	PMEYDM-350	12.5	9.19	4.83	3.44	PMEYDM-350-A
4"	PMEYDM-400	16.7	9.75	5.33	3.50	PMEYDM-400-A

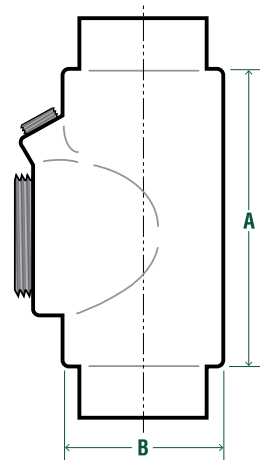

EYSEF - EXPANDED FILL FEMALE HUBS FOR SEALING IN VERTICAL OR HORIZONTAL POSITIONS

PIPE SIZE	FERROUS CATALOG #	NOMINAL WEIGHT	A	B	TURNING RADIUS	ALUMINUM CATALOG #
1/2"	PMEYSEF-50	1.5	3.69	1.58	1.25	PMEYSEF-50-A
3/4"	PMEYSEF-75	2.1	4.31	1.83	1.38	PMEYSEF-75-A
1"	PMEYSEF-100	2.7	5.06	2.27	1.72	PMEYSEF-100-A
1-1/4"	PMEYSEF-125	3.7	6.25	3.08	2.31	PMEYSEF-125-A
1-1/2"	PMEYSEF-150	4.7	6.25	3.08	2.31	PMEYSEF-150-A
2"	PMEYSEF-200	6.7	8.50	4.33	3.31	PMEYSEF-200-A
2-1/2"	PMEYSEF-250	7.7	9.19	4.83	3.44	PMEYSEF-250-A
3"	PMEYSEF-300	8.7	9.75	5.33	3.69	PMEYSEF-300-A
3-1/2"	PMEYSEF-350	9.7	11.06	6.58	4.59	PMEYSEF-350-A
4"	PMEYSEF-400	10.7	11.06	6.58	4.59	PMEYSEF-400-A

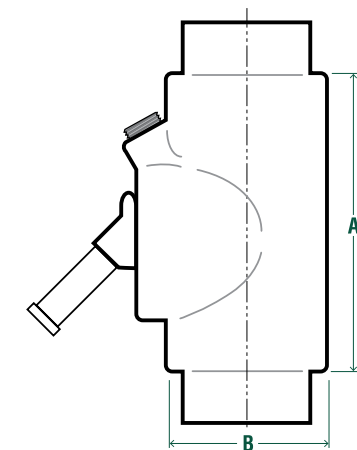

EYDEF - EXPANDED FILL FEMALE HUBS WITH DRAIN FOR SEALING IN VERTICAL POSITIONS ONLY

PIPE SIZE	FERROUS CATALOG #	NOMINAL WEIGHT	A	B	TURNING RADIUS	ALUMINUM CATALOG #
1/2"	PMEYDEF-50	1.7	3.69	1.83	1.91	PMEYDEF-50-A
3/4"	PMEYDEF-75	2.3	4.31	2.27	2.38	PMEYDEF-75-A
1"	PMEYDEF-100	2.5	5.06	2.27	1.84	PMEYDEF-100-A
1-1/4"	PMEYDEF-125	4.0	6.25	3.08	2.31	PMEYDEF-125-A
1-1/2"	PMEYDEF-150	4.7	6.25	3.08	2.31	PMEYDEF-150-A
2"	PMEYDEF-200	9.0	8.50	4.33	3.31	PMEYDEF-200-A
2-1/2"	PMEYDEF-250	10.2	9.19	4.83	3.44	PMEYDEF-250-A
3"	PMEYDEF-300	10.5	9.75	5.33	3.50	PMEYDEF-300-A

Sealing Fittings

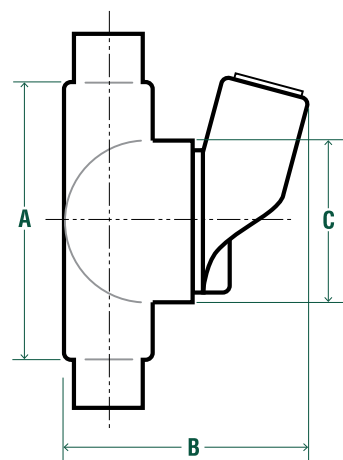

EZS - FEMALE HUBS
FOR SEALING IN ANY POSITION

PIPE SIZE	FERROUS CATALOG #	NOMINAL WEIGHT	A	B	C	TURNING RADIUS
1/2"	PMEZS-50	2.0	4.19	3.71	2.58	1.88
3/4"	PMEZS-75	2.3	4.19	3.71	2.58	1.88
1"	PMEZS-100	2.7	4.94	4.05	3.08	2.13
1-1/4"	PMEZS-125	3.5	5.06	4.49	3.08	2.31
1-1/2"	PMEZS-150	4.0	5.19	4.64	3.33	2.34
2"	PMEZS-200	8.2	7.06	5.49	5.27	3.28
2-1/2"	PMEZS-250	8.5	7.94	5.92	5.27	3.38
3"	PMEZS-300	9.0	8.63	6.58	5.96	3.88

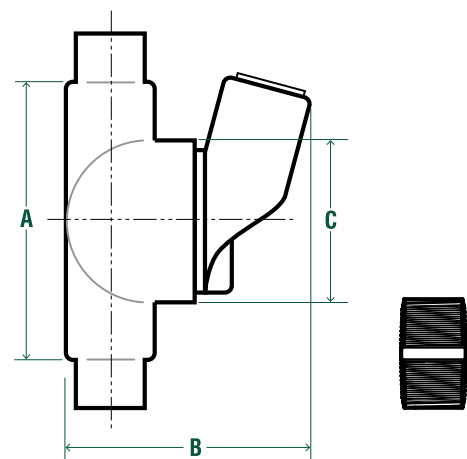

EZDM - MALE/FEMALE HUBS WITH DRAIN
FOR SEALING IN ANY POSITION

PIPE SIZE	FERROUS CATALOG #	NOMINAL WEIGHT	A	B	C	TURNING RADIUS
1/2"	PMEZDM-50	2.0	4.19	3.71	2.58	1.88
3/4"	PMEZDM-75	2.4	4.19	3.71	2.58	1.88
1"	PMEZDM-100	3.0	4.94	4.05	3.08	2.13
1-1/4"	PMEZDM-125	4.0	5.06	4.49	3.08	2.31
1-1/2"	PMEZDM-150	4.6	5.19	4.64	3.33	2.34
2"	PMEZDM-200	6.9	7.06	5.49	5.27	3.28
2-1/2"	PMEZDM-250	9.2	7.94	5.92	5.27	3.38
3"	PMEZDM-300	8.7	8.63	6.58	5.96	3.88

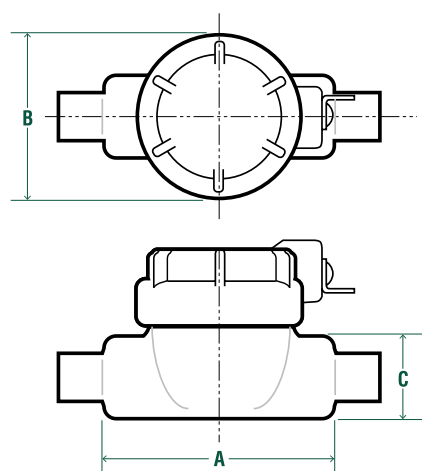

EZD - FEMALE HUBS WITH DRAIN AND INSPECTION COVER
FOR SEALING IN VERTICAL POSITIONS ONLY

PIPE SIZE	FERROUS CATALOG #	A	B	C	TURNING RADIUS
1/2"	PMEZD-50	4.19	3.08	3.46	2.06
3/4"	PMEZD-75	4.19	3.08	3.71	2.19
1"	PMEZD-100	4.94	3.58	3.96	2.44
1-1/4"	PMEZD-125	4.94	3.58	4.39	2.63
1-1/2"	PMEZD-150	5.19	3.58	4.64	2.69
2"	PMEZD-200	7.13	5.64	5.33	3.69

Sealing Compounds

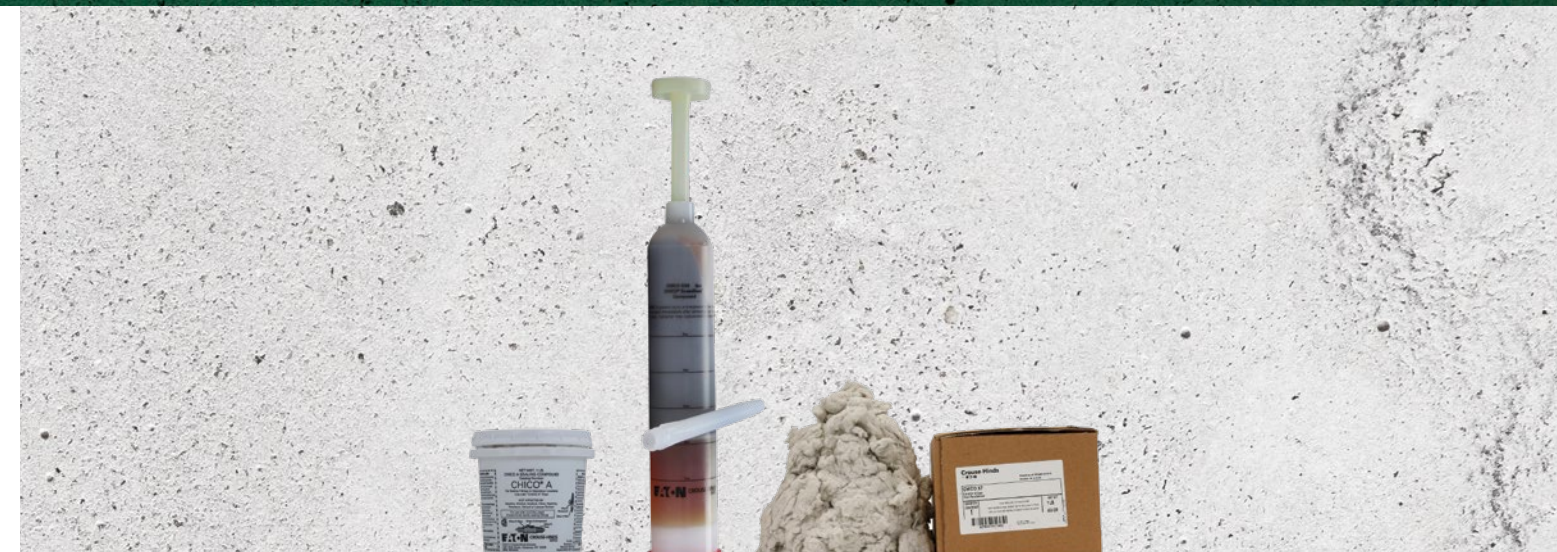

DESCRIPTION

Chico sealing compounds and fiber are used to form a seal around and between each electrical conductor, and inside of the sealing fitting to restrict the passage of gases, vapors or flames.

Chico A sealing compound is a water soluble powder that can be easily mixed and poured. The dense compound expands slightly when hardening and bonds to inner walls of sealing fittings. **Chico A-P Intrapak** is packaged in a two compartment plastic pouch with precise amount of water for mixing. No measuring is required, speeding up the installation process. **Chico X fiber** forms a dam between the integral bushing of the sealing fitting and the end of the conduit and around the electrical conductors entering the hub. It is a mineral wool that packs easily, forming around each conductor.

Chico SpeedSeal compound lets you reliably install a complete explosionproof seal in five minutes. Chico SpeedSeal comes in a self-contained applicator kit that eliminates the need for measuring before mixing. Just pump to mix the material, inject the pre-measured amount, replace the plug and the fitting is sealed. Chico SpeedSeal expands after injection to tightly fill the entire fitting, automatically separating the conductors. The time-consuming and tedious task of packing fiber to separate the individual conductors is eliminated. Once cured, Chico SpeedSeal forms an explosionproof seal around each electrical conductor in Eaton's Crouse-Hinds series EYS and EYD sealing fittings, restricting the passage of gases, vapors or flames through the sealing fitting.

STANDARDS

Chico A, Chico A-P, Chico X

- Class I, Division 1, Groups A, B, C, D
- Class II, Division 1, Groups E, F, G

Chico SpeedSeal

- Class I, Division 1, Groups C, D
- Class II, Division 1, Groups E, F, G

CATALOG #	DESCRIPTION
PMCHICOA3	Chico A 1lb bucket
PMCHICOA4	Chico A 1lb bucket with 1oz Chico X Fiber
PMCHICOA05	Chico A 5lb bucket
PMCHICOA19PX	Chico A-P Intrapak 5 cubic inch fill
PMCHICOA39PX	Chico A-P Intrapak II cubic inch fill
PMCHICOSS2	Chico SpeedSeal 2oz
PMCHICOSS6	Chico SpeedSeal 6oz
PMCHICOX4	Chico X Fiber 2oz
PMCHICOX6	Chico X Fiber 8oz
PMCHICOX7	Chico X Fiber 1lb

ECGJH and ECLK Series Couplings



DESCRIPTION

EC Series couplings are used in hazardous areas where a flexible member is required in a conduit system to accomplish difficult bends or to allow for movement or vibration of connected equipment or units.

FEATURES

- 40 mil gray PVC exterior coating
- Rugged design to withstand explosive pressure (Class I) and mechanical abuse
- Liquid tight for wet locations
- For use where lack of space makes use of rigid conduit difficult
- Wire duct liner in sizes from 1/2" through 2" insulates against grounds and burn-through from short circuit
- No bonding jumpers required; metallic braid provides continuous electrical path
- ECGJH combination has two threaded male end fittings
- ECLK combination has one female union and one male threaded end fitting

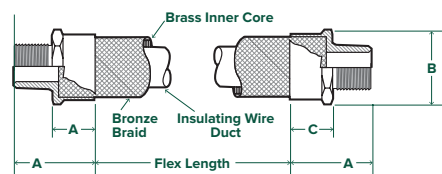

DIMENSIONS (IN INCHES)

HUB SIZE	A	B	C	D	E
1/2"	1-7/8	1-1/2	1-1/8	3	1-9/16
3/4"	2-1/16	1-7/8	1-3/16	3-1/4	1-13/16
1"	2-1/2	2-1/8	1-1/2	3-5/8	1-7/8
1-1/4"	2-7/8	2-15/16	1-7/8	4-3/16	2-3/4
1-1/2"	3-5/16	3-1/2	1-7/8	5-3/16	3-1/16
2"	3-1/4	4-1/4	2	5-1/16	3-13/16
2-1/2"	3	4-7/16	1-5/8	5-1/16	4-5/16
3"	3-1/8	4-9/16	1-3/4	5-3/8	5-1/16
4"	4-5/8	4-15/16	3-1/4	7-1/2	6-3/16

STANDARDS

NEC/CEC

- 1/2" and 3/4": Class I, Division I, Groups A, B, C, D
- 1" through 2": Class I, Division I, Groups C, D
- All sizes for use in Class II, Division I, Groups E, F, G; Class III

UL Standard

- UL 1203
- CSA C22.2 NO.30

Standard Materials and Fittings

- End fittings – 1/2" through 2": forged brass, natural; 2 1/2" through 4": stainless steel, natural
- Female unions – 1/2" through 1": steel, electrogalvanized with PVC coating; 1 1/4" through 4": Feraloy® iron alloy, electrogalvanized with PVC coating
- 1/2" through 2" have bronze braid covering and flexible brass inner core; packing is woven cotton braid impregnated with asphalt
- 2 1/2" through 4" have a Type 304 stainless steel braid

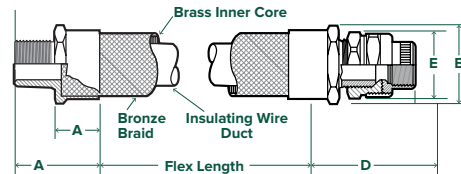

MINIMUM RECOMMENDED RADIUS OF BEND

HUB SIZE	RADIUS
1/2"	10
3/4"	12
1"	14
1-1/4"	14
1-1/2"	16
2"	16
2-1/2"	16
3"	18
4"	30

ECGJH - MALE/MALE

FLEXIBLE LENGTH	HUB SIZE	CATALOG #
4	1/2	PMECGJH14
4	3/4	PMECGJH24
6	1/2	PMECGJH16
6	3/4	PMECGJH26
6	1	PMECGJH36
8	1/2	PMECGJH18
8	3/4	PMECGJH28
8	1	PMECGJH38
10	1/2	PMECGJH10
10	3/4	PMECGJH20
10	1	PMECGJH30
12	1/2	PMECGJH12
12	3/4	PMECGJH22
12	1	PMECGJH32
12	1-1/4	PMECGJH42
12	1-1/2	PMECGJH52
12	2	PMECGJH62
12	2-1/2	PMECGJH72
12	3	PMECGJH82
12	4	PMECGJH102
15	1/2	PMECGJH15
15	3/4	PMECGJH25
15	1	PMECGJH35

FLEXIBLE LENGTH	HUB SIZE	CATALOG #
15	1-1/4	PMECGJH45
15	1-1/2	PMECGJH55
15	2	PMECGJH65
15	2-1/2	PMECGJH75
15	3	PMECGJH85
15	4	PMECGJH105
18	1/2	PMECGJH18
18	3/4	PMECGJH28
18	1	PMECGJH38
18	1-1/4	PMECGJH48
18	1-1/2	PMECGJH58
18	2	PMECGJH68
18	2-1/2	PMECGJH78
18	3	PMECGJH88
18	4	PMECGJH108
21	1/2	PMECGJH21
21	3/4	PMECGJH31
21	1	PMECGJH41
21	1-1/4	PMECGJH51
21	1-1/2	PMECGJH61
21	2-1/2	PMECGJH71
21	3	PMECGJH81

FLEXIBLE LENGTH	HUB SIZE	CATALOG #
21	4	PMECGJH1021
24	1/2	PMECGJH24
24	3/4	PMECGJH24
24	1	PMECGJH324
24	1-1/4	PMECGJH424
24	1-1/2	PMECGJH524
24	2	PMECGJH624
24	2-1/2	PMECGJH724
24	3	PMECGJH824
24	4	PMECGJH1024
27	1/2	PMECGJH127
27	3/4	PMECGJH227
27	1	PMECGJH327
27	1-1/4	PMECGJH427
27	1-1/2	PMECGJH527
27	2	PMECGJH627
27	2-1/2	PMECGJH727
27	3	PMECGJH827
27	4	PMECGJH1027
30	1/2	PMECGJH130
30	3/4	PMECGJH230
30	1	PMECGJH330
30	1-1/4	PMECGJH430

FLEXIBLE LENGTH	HUB SIZE	CATALOG #
30	1-1/2	PMECGJH530
30	2	PMECGJH630
30	2-1/2	PMECGJH730
30	3	PMECGJH830
30	4	PMECGJH1030
33	1/2	PMECGJH133
33	3/4	PMECGJH233
33	1	PMECGJH333
33	1-1/4	PMECGJH433
33	1-1/2	PMECGJH533
33	2	PMECGJH633
33	2-1/2	PMECGJH733
33	3	PMECGJH833
33	4	PMECGJH1033
36	1/2	PMECGJH136
36	3/4	PMECGJH236
36	1	PMECGJH336
36	1-1/4	PMECGJH436
36	1-1/2	PMECGJH536
36	2	PMECGJH636
36	2-1/2	PMECGJH736
36	3	PMECGJH836
36	4	PMECGJH1036

ECLK - MALE/FEMALE

FLEXIBLE LENGTH	HUB SIZE	CATALOG #
4	1/2	PMECLK14
4	3/4	PMECLK24
6	1/2	PMECLK16
6	3/4	PMECLK26
6	1	PMECLK36
8	1/2	PMECLK18
8	3/4	PMECLK28
8	1	PMECLK38
10	1/2	PMECLK10
10	3/4	PMECLK20
10	1	PMECLK30
12	1/2	PMECLK12
12	3/4	PMECLK22
12	1	PMECLK32
12	1-1/4	PMECLK42
12	1-1/2	PMECLK52
12	2	PMECLK62
12	2-1/2	PMECLK72
12	3	PMECLK82
12	4	PMECLK102
15	1/2	PMECLK15
15	3/4	PMECLK25
15	1	PMECLK35

FLEXIBLE LENGTH	HUB SIZE	CATALOG #
15	1-1/4	PMECLK45
15	1-1/2	PMECLK55
15	2	PMECLK65
15	2-1/2	PMECLK75
15	3	PMECLK85
15	4	PMECLK105
18	1/2	PMECLK18
18	3/4	PMECLK28
18	1	PMECLK38
18	1-1/4	PMECLK48
18	1-1/2	PMECLK58
18	2	PMECLK68
18	2-1/2	PMECLK78
18	3	PMECLK88
18	4	PMECLK108
21	1/2	PMECLK21
21	3/4	PMECLK31
21	1	PMECLK41
21	1-1/4	PMECLK51
21	1-1/2	PMECLK61
21	2-1/2	PMECLK71
21	3	PMECLK81

FLEXIBLE LENGTH	HUB SIZE	CATALOG #
21	4	PMECLK1021
24	1/2	PMECLK124
24	3/4	PMECLK224
24	1	PMECLK324
24	1-1/4	PMECLK424
24	1-1/2	PMECLK524
24	2	PMECLK624
24	2-1/2	PMECLK724
24	3	PMECLK824
24	4	PMECLK1024
27	1/2	PMECLK127
27	3/4	PMECLK227
27	1	PMECLK327
27	1-1/4	PMECLK427
27	1-1/2	PMECLK527
27	2	PMECLK627
27	2-1/2	PMECLK727
27	3	PMECLK827
27	4	PMECLK1027
30	1/2	PMECLK130
30	3/4	PMECLK230
30	1	PMECLK330
30	1-1/4	PMECLK430

FLEXIBLE LENGTH	HUB SIZE	CATALOG #
30	1-1/2	PMECLK530
30	2	PMECLK630
30	2-1/2	PMECLK730
30	3	PMECLK830
30	4	PMECLK1030
33	1/2	PMECLK133
33	3/4	PMECLK233
33	1	PMECLK333
33	1-1/4	PMECLK433
33	1-1/2	PMECLK533
33	2	PMECLK633
33	2-1/2	PMECLK733
33	3	PMECLK833
33	4	PMECLK1033
36	1/2	PMECLK136
36	3/4	PMECLK236
36	1	PMECLK336
36	1-1/4	PMECLK436
36	1-1/2	PMECLK536
36	2	PMECLK636
36	2-1/2	PMECLK736
36	3	PMECLK836
36	4	PMECLK1036

OE Series Outlet Boxes



DESCRIPTION

Perma-Cote OE Series conduit outlet boxes are installed in hazardous location conduit systems to serve as pulling and splicing fittings, connect runs of conduit, change the direction of a conduit run, or to provide access to conductors. They are provided with covers. Electrical continuity of the conduit system is maintained across assembled joints.

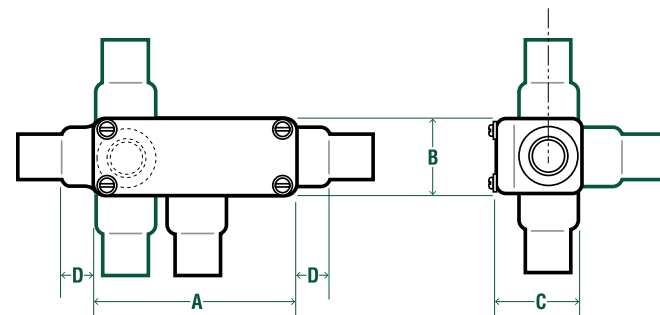

FEATURES

- 40 mil gray PVC exterior coating
- 2 mil green urethane interior coating
- Available in 1/2" or 3/4" trade sizes
- PVC-coating on outer edge of cover provides additional protection to seal out corrosives
- Sealing sleeves on all female conduit openings
- Compact design saves space
- Encapsulated stainless steel cover screws

STANDARDS

- NEC/CEC
 - Class I, Division 1 & 2, Groups C, D
 - Class II, Division 1, Groups E, F, G
 - Class II, Division 2, Groups F, G
 - Class III

OELB OUTLET BOXES

PIPE SIZE	FERROUS CATALOG #	NOMINAL WEIGHT	A	B	C	D
1/2"	PMOELB50	2.2	4.14	1.64	1.89	0.69
3/4"	PMOELB75	3.0	4.39	1.96	2.14	0.69

OET OUTLET BOXES

PIPE SIZE	FERROUS CATALOG #	NOMINAL WEIGHT	A	B	C	D
1/2"	PMOET50	2.2	4.14	1.64	1.89	0.69
3/4"	PMOET75	3.0	4.39	1.96	2.14	0.69

OE SCREW KIT

CATALOG #	FOR USE WITH
????	PROET1 & PROELB1
????	PROET2 & PROELB2

Support Products

PIPE STRAPS

DESCRIPTION

Perma-Cote PVC-coated pipe straps are used to securely mount conduit to a wall or other structure for support. They are available in two styles: a one-hole malleable iron strap or a two-hole stamped steel strap. Mounting hardware not provided.



CONDUIT PIPE STRAP - 1 HOLE

PIPE SIZE	FERROUS CATALOG #	NOMINAL WEIGHT FOR 100
1/2"	PMI4-50G	11
3/4"	PMI4-75G	14
1"	PMI4-100G	12
1-1/4"	PMI4-125G	25
1-1/2"	PMI4-150G	36
2"	PMI4-200G	71
2-1/2"	PMI4-250G	111
3"	PMI4-300G	134
3-1/2"	PMI4-350G	166
4"	PMI4-400G	256

FEATURES

- 20 mil gray PVC exterior coating
- 10 trade sizes from 1/2" through 4"



CONDUIT PIPE STRAP - 2 HOLE

PIPE SIZE	FERROUS CATALOG #	NOMINAL WEIGHT FOR 100
1/2"	PMHS-901	2.0
3/4"	PMHS-902	3.0
1"	PMHS-903	4.0
1-1/4"	PMHS-904	4.5
1-1/2"	PMHS-905	5.0
2"	PMHS-906	10.0
2-1/2"	PMHS-907	13.0
3"	PMHS-908	17.0
3-1/2"	PMHS-909	20.0
4"	PMHS-910	25.0

CLAMP BACK SPACERS

DESCRIPTION

Perma-Cote PVC-coated clamp back spacers are used with malleable or stamped pipe straps to provide a mounting stand-off for a conduit from a wall or other structure.



CONDUIT CLAMP BACK SPACER

PIPE SIZE	FERROUS CATALOG #	NOMINAL WEIGHT EACH
1/2"	PMI41-G	0.1
3/4"	PMI42-G	0.1
1"	PMI43-G	0.1
1-1/4"	PMI44-G	0.2
1-1/2"	PMI45-G	0.2
2"	PMI46-G	0.3
2-1/2"	PMI47-G	1.0
3"	PMI48-G	1.7
3-1/2"	????	1.8
4"	PMI50-G	2.0

FEATURES

- 20 mil gray PVC exterior coating
- 10 trade sizes from 1/2" through 4"

CONDUIT CLAMP HANGERS



DESCRIPTION

Perma-Cote PVC-coated conduit clamp hangers are used with threaded rod to securely suspend conduit runs supported from above. They are provided with stainless steel hardware.

FEATURES

- 20 mil gray PVC exterior coating
- 10 trade sizes from 1/2" through 4"

PIPE SIZE	CATALOG #	NOMINAL WEIGHT
1/2"	PMH0WBS	0.1
3/4"	PMH1WBS	0.1
1"	PMH2WBS	0.1
1-1/4"	PMH3WBS	0.1
1-1/2"	PMH4WBS	0.2
2"	PMH5WBS	0.3
2-1/2"	PMH6WBS	0.4
3"	PMH7WBS	0.5
3-1/2"	PMH8WBS	0.6
4"	PMH9WBS	0.7

PVC-COATED ALL THREAD ROD



DESCRIPTION

PVC-coated all thread rod is used as a fastening or supporting means in electrical and mechanical installations in industrial facilities – inside or outside - where corrosion is a concern. Typical uses include overhead and trapeze mounting with coated products like conduit and pipe hangers, beam clamps, strut, split ring hangers and stainless steel or aluminum Rocket Rack® Standard support platform products.

FEATURES

- Available in 1/2" & 3/8" diameter rod in 6' & 12' lengths
- Black PVC exterior coating with inner adhesive liner for permanent impermeable seal
- 304 stainless rod for strength and corrosion resistance
- All thread design eliminates need for field threading

INSTALLATION TIP!

Use the Rod Stripping tool to aid in trimming the PVC.

SIZE	CATALOG #
1/2" X 6'	PMCR304061/2
3/8" X 6'	PMCR304063/8
1/2" X 12'	PMCR304121/2
3/8" X 12'	PMCR304123/8

PVC-COATED STRUT STRAPS AND J HANGERS

DESCRIPTION

Perma-Cote PVC-coated strut straps and J hangers are used with coated strut to support conduit installations in a variety of configurations. Strut straps may be used in either vertical or horizontal positions to support conduit. Both are provided with stainless steel hardware. Conduit spacing may be as close together as allowed by the couplings. J hangers may be used with hanger rods or other means of support to securely fasten conduit runs.

FEATURES

- 20 mil gray PVC exterior coating
- Available in 11 trade sizes



PVC-COATED STRUT STRAPS

SIZE	FERROUS CATALOG #	GAUGE METAL	WEIGHT FOR 100 PCS	STD PACK
1/2"	PMB2008	14	13.0	100
3/4"	PMB2009	14	15.0	100
1"	PMB2010	14	17.0	100
1-1/4"	PMB2011	12	19.5	100
1-1/2"	PMB2012	12	28.0	100
2"	PMB2013	12	31.0	50
2-1/2"	PMB2014	12	36.0	50
3"	PMB2015	12	42.0	50
3-1/2"	PMB2016	11	56.0	25
4"	PMB2017	11	64.0	25
5"	PMB2019	10	76.0	25

PVC-COATED J HANGERS

SIZE	FERROUS CATALOG #	WEIGHT FOR 100 PCS	STD PACK
1/2"	PMB3690-1/2	18	25
3/4"	PMB3690-3/4	21	25
1"	PMB3690-1	22	25
1-1/4"	PMB3690-1-1/4	25	25
1-1/2"	PMB3690-1-1/2	27	25
2"	PMB3690-2	29	25
2-1/2"	PMB3690-2-1/2	64	25
3"	PMB3690-3	72	25
3-1/2"	PMB3690-3-1/2	84	25
4"	PMB3690-4	138	10
5"	PMB3690-5	162	10



PVC-COATED FERROUS STRUTS

DESCRIPTION

Perma-Cote PVC-coated strut is a versatile system of structural elements that can be used to build supports for a variety of applications. When combined with coated conduit hangers and other accessories, coated strut is a versatile and economical way to provide reliable support for conduit runs and other electrical and mechanical installations.

FEATURES

- 20 mil gray PVC exterior coating
- 2 trade sizes and 3 standard styles

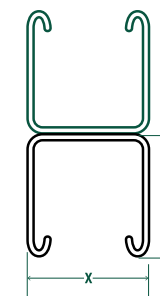

PVC-COATED STRUT

FERROUS CATALOG #	STYLE	NOMINAL WEIGHT PER 100 FT.	X	Y	STRUT THICKNESS
PMP1000-10	CHANNEL	200.0	1.67	1.67	12 GA.
PMSH1000-10	CHANNEL SLOTTED	185.0	1.67	1.67	12 GA.
PMP1001-10	CHANNEL BACK TO BACK	380.0	1.67	3.29	12 GA.
PMP3300-10	CHANNEL SHALLOW	135.0	1.67	0.92	12 GA.
PMSH3300-10	CHANNEL SHALLOW SLOTTED	130.0	1.67	0.92	12 GA.

PVC-COATED STRUT CUT-TO-LENGTH

FERROUS CATALOG #	DESCRIPTION	X	Y	LENGTH IN FT.	STRUT THICKNESS
PMP1000-1	1-5/8 CHANNEL	1.67	1.67	1	12 GA.
PMP1000-1-1/2	1-5/8 CHANNEL	1.67	1.67	1-1/2	12 GA.
PMP1000-2	1-5/8 CHANNEL	1.67	1.67	2	12 GA.
PMP1000-2-1/2	1-5/8 CHANNEL	1.67	1.67	2-1/2	12 GA.
PMP1000-3	1-5/8 CHANNEL	1.67	1.67	3	12 GA.

CHANNELS WITH SLOTTED HOLES

FERROUS CATALOG #	DESCRIPTION	X	Y	LENGTH IN FT.	STRUT THICKNESS
PMSH1000-1	1-5/8 CHANNEL	1.67	1.67	1	12 GA.
PMSH1000-1-1/2	1-5/8 CHANNEL	1.67	1.67	1-1/2	12 GA.
PMSH1000-2	1-5/8 CHANNEL	1.67	1.67	2	12 GA.
PMSH1000-2-1/2	1-5/8 CHANNEL	1.67	1.67	2-1/2	12 GA.
PMSH1000-3	1-5/8 CHANNEL	1.67	1.67	3	12 GA.

PVC-COATED STRUT NUTS

DESCRIPTION

Perma-Cote PVC-coated strut nuts are used to assemble strut components and to secure coated all thread rod in a section of strut. These are available with or without a spring to aid in placement and assembly.

FEATURES

- 20 mil gray PVC exterior coating
- 10 trade sizes from 1/2" through 4"



PIPE SIZE	FERROUS CATALOG #
3/8"	PMN228-WO
1/2"	PMN225-WO
3/8"	PMN228
1/2"	PMN225
3/8"	PMN2500-375
1/2"	PMN2500-050

Support Products

BEAM CLAMPS AND U-BOLTS

DESCRIPTION

Perma-Cote PVC-coated beam clamps are used to securely support conduit runs by attaching them to beams, angles, trusses, and other structural members. They are available in the following styles:

Window Clamp – to attach strut at a 90° angle to a beam or structural member

Parallel – to attach the conduit run parallel to a beam or structural member

Edge – to attach the conduit run at a 90° angle to a thin beam or structural member

Right Angle – to attach the conduit run at a 90° angle to a beam or structural member

U-Bolt – to attach the conduit run to a structural member or support

Hanger Rod Beam Clamp – to attach a single all thread rod to a beam or structural member

FEATURES

- 20 mil minimum gray PVC exterior coating on all types of beam clamps
- Right angle clamps supplied with plastic encapsulated screws
- All clamps specifically sized to fit PVC-coated conduit
- Right angle and parallel clamps available in 10 trade sizes from ½" through 4"
- Edge clamps available in 3 trade sizes from ½" through 1"
- Hanger rod beam clamps available with 5 different jaw openings from 15/16" through 2 1/8"
- U-Bolts available in 12 trade sizes from ½" through 6"



STRUT WINDOW BEAM CLAMPS

FERROUS CATALOG #	DESCRIPTION	NOMINAL WEIGHT
PMB441-22	5/16" ENC NUTS-RA, UBLT 1/2" to 1-1/4"	0.9
PMB441-22A	3/8" ENC NUTS-RA, UBLT 1-1/2" to 6"	0.9



PVC-COATED NUTS

FERROUS CATALOG #	DESCRIPTION
PMNUT-KIT-1	5/16" ENC NUTS-RA, UBLT 1/2" to 1-1/4"
PMNUT-KIT-2	3/8" ENC NUTS-RA, UBLT 1-1/2" to 6"



PARALLEL CONDUIT CLAMPS

PIPE SIZE	FERROUS CATALOG #	NOMINAL WEIGHT
1/2"	PMUPC-50	46.8
3/4"	PMUPC-75	63.0
1"	PMUPC-100	67.0
1-1/4"	PMUPC-125	100.0
1-1/2"	PMUPC-150	130.0
2"	PMUPC-200	158.0
2-1/2"	PMUPC-250	175.0
3"	PMUPC-300	200.0
3-1/2"	PMUPC-350	250.0
4"	PMUPC-400	275.0

EDGE-STYLE CONDUIT CLAMPS

PIPE SIZE	FERROUS CATALOG #	NOMINAL WEIGHT
1/2"	PMUEC-50	74.0
3/4"	PMUEC-75	90.0
1"	PMUEC-100	100.0



RIGHT ANGLE CONDUIT CLAMPS

PIPE SIZE	FERROUS CATALOG #	NOMINAL WEIGHT
1/2"	PMRA-50	49.0
3/4"	PMRA-75	53.0
1"	PMRA-100	61.0
1-1/4"	PMRA-125	65.0
1-1/2"	PMRA-150	92.0
2"	PMRA-200	100.0
2-1/2"	PMRA-250	125.0
3"	PMRA-300	150.0
3-1/2"	PMRA-350	175.0
4"	PMRA-400	198.0



CONDUIT U-BOLTS

PIPE SIZE	FERROUS CATALOG #	NOMINAL WEIGHT
1/2"	PMU-050-PVC	17.0
3/4"	PMU-075-PVC	18.0
1"	PMU-100-PVC	20.0
1-1/4"	PMU-125-PVC	20.0
1-1/2"	PMU-150-PVC	31.0
2"	PMU-200-PVC	34.0
2-1/2"	PMU-250-PVC	39.0
3"	PMU-300-PVC	44.0
3-1/2"	PMU-350-PVC	45.0
4"	PMU-400-PVC	49.0
5"	PMU-500-PVC	100.0
6"	PMU-600-PVC	130.0



HANGER ROD BEAM CLAMPS

FERROUS CATALOG #	A THREADED HOLE	B BOLT SIZE	C JAW OPENING	MAXIMUM LOAD
PMIS-500	1/4" – 20"	5/16" – 18"	25/32"	120
PMIS-501	5/16" – 18"	3/8" – 16"	27/32"	300
PMIS-502	3/8" – 16"	1/2" – 13"	1-3/32"	300
PMIS-503	1/2" – 13"	5/8" – 11"	15/16"	600
PMIS-508	1/2" – 13"	1/2" – 13"	2-3/32"	1250

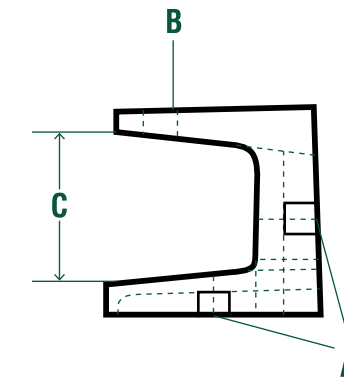

Stainless Steel Accessories

DRAIN PLUGS

Stainless

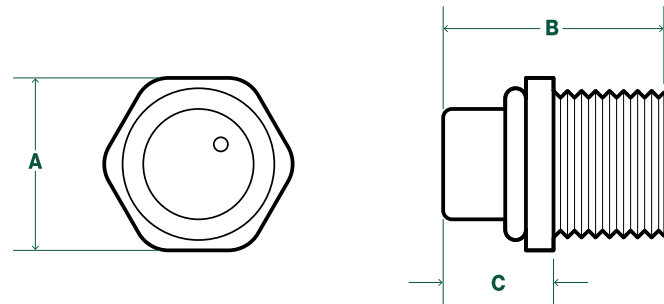

DESCRIPTION

Robroy Stainless Drain Plugs allow for an easy method to drain an assembly reducing accumulation of water, fluids and condensation. Locknut included as standard.

CATALOG #	DESCRIPTION	WEIGHT EACH (LBS.)	A WIDTH ACROSS FLATS (IN.)	B LENGTH (IN.)	C OUTSIDE LENGTH (IN.)
RSDP116	Drain Plug 1/2 Inch 316	0.11	0.98	1.26	0.63
RSDP216	Drain Plug 3/4 Inch 316	0.16	1.18	1.26	0.63

BASKET DRAINS

Stainless



STANDARDS

- cULus Listed
- UL 514B
- UL File Number: E511845

DESCRIPTION

Robroy Stainless Basket Drains are 304 stainless steel and are designed to provide means for the release of condensation within a conduit system.

CATALOG #	DESCRIPTION	WEIGHT EACH (LBS.)
RSBDR104	Basket Drain 1/2 Inch 304	0.08
RSBDR204	Basket Drain 3/4 Inch 304	0.18

HYGIENIC PLUGS

Hygienic

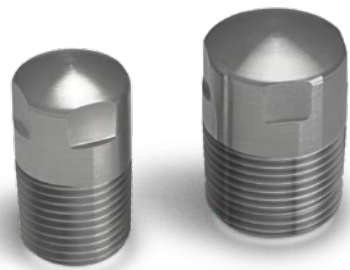

STANDARDS

- cULus Listed
- UL 1203
- CSA 22.2 No. 25-17
- CSA 22.2 No. 30
- UL File Number: E476062
- Class I, Div 1 Grp A,B,C,D
- Class II, Div 1 Grp E, F, G

DESCRIPTION

Robroy Stainless Hygienic Plugs are 316 stainless steel and are specially designed for the hygienic system. These can be used in conjunction with hygienic reducers to accommodate larger trade sizes. Plugs are also listed for hazardous locations.

CATALOG #	DESCRIPTION	WEIGHT EACH (LBS.)	OVERALL LENGTH (IN.)	OUTSIDE DIAMETER (IN.)
RSPLG116	Hygienic Plug 1/2 Inch 316	0.21	1.50	0.84
RSPLG216	Hygienic Plug 3/4 Inch 316	0.33	1.50	1.05

LOW POINT DRAINS

Stainless



STANDARDS

- cULus Listed
- UL 514A
- UL File number E511845
- CSA C22.2 No. 18-1

DESCRIPTION

Robroy Stainless Low Point Drains are designed to be used in connection with Robroy Stainless conduit bodies and provide an exit point for water or accumulated condensation in electrical raceway systems. The sleek, rounded construction adheres with hygienic design principles. The low point drain is available in 1/2", 3/4" & 1" trade sizes and is produced from corrosion resistant 316 grade stainless steel.

CATALOG #	DESCRIPTION	WEIGHT EACH (LBS.)
RSLPD116	Low Point Drain 1/2 Inch 316	0.11
RSLPD216	Low Point Drain 3/4 Inch 316	0.16
RSLPD316	Low Point Drain 1 Inch 316	0.21

Stainless Steel Accessories

ONE AND TWO HOLE STRAPS

Stainless



DESCRIPTION

Robroy Stainless One and Two Hole Straps are made from 316 stainless steel and are used to secure rigid or PVC-coated conduit to a wall or other types of supports.

STANDARDS

- cULus Listed
- UL 2239
- UL File Number: E216996

CATALOG #	DESCRIPTION	WEIGHT EACH (LBS.)
RSIHS116	One Hole Strap 1/2 Inch 316	0.03
RSIHS216	One Hole Strap 3/4 Inch 316	0.05
RSIHS316	One Hole Strap 1 Inch 316	0.06
RSIHS416	One Hole Strap 1-1/4 Inch 316	0.08
RSIHS516	One Hole Strap 1-1/2 Inch 316	0.16
RSIHS616	One Hole Strap 2 Inch 316	0.22
RSIHS716	One Hole Strap 2-1/2 Inch 316	0.49
RSIHS816	One Hole Strap 3 Inch 316	0.56
RSIHS1016	One Hole Strap 4 Inch 316	0.69
RS2HS116	Two Hole Strap 1/2 Inch 316	0.02
RS2HS216	Two Hole Strap 3/4 Inch 316	0.03
RS2HS316	Two Hole Strap 1 Inch 316	0.04
RS2HS416	Two Hole Strap 1-1/4 Inch 316	0.06
RS2HS516	Two Hole Strap 1-1/2 Inch 316	0.07
RS2HS616	Two Hole Strap 2 Inch 316	0.10
RS2HS716	Two Hole Strap 2-1/2 Inch 316	0.18
RS2HS816	Two Hole Strap 3 Inch 316	0.21
RS2HS1016	Two Hole Strap 4 Inch 316	0.27

RIGHT ANGLE CLAMPS

Stainless



DESCRIPTION

Robroy Stainless Right Angle Clamps are made from 316 stainless steel and are designed to secure rigid or PVC-coated conduit perpendicular to beam, channel and angle supports.

STANDARDS

- cULus Listed
- UL 2239
- UL File Number: E216996

CATALOG #	DESCRIPTION	WEIGHT EACH (LBS.)
RSRAC116	Right Angle Clamp 1/2 Inch 316	0.30
RSRAC216	Right Angle Clamp 3/4 Inch 316	0.34
RSRAC316	Right Angle Clamp 1 Inch 316	0.39
RSRAC416	Right Angle Clamp 1-1/4 Inch 316	0.44
RSRAC516	Right Angle Clamp 1-1/2 Inch 316	0.52
RSRAC616	Right Angle Clamp 2 Inch 316	0.71
RSRAC716	Right Angle Clamp 2-1/2 Inch 316	0.90
RSRAC816	Right Angle Clamp 3 Inch 316	1.04
RSRAC1016	Right Angle Clamp 4 Inch 316	1.27

CLAMP BACK SPACERS

Stainless

DESCRIPTION

Robroy Stainless universal clamp back spacer is designed for use with stainless steel rigid conduit and stainless steel one and two hole mounting straps to provide additional spacing between conduit and wall or mounting surface. Quarter inch raise provides gap from surface to facilitate turning or connecting conduit. Unique design allows for use in securing 1/2" or 3/4" trade size conduit in conjunction with a one strap or 1/2", 3/4" or 1" trade size conduit with a two hole strap. Stamped 316 stainless steel material provides strong, sturdy construction and superior corrosion resistance.

STANDARDS

- UL Listed
- UL 2239
- CSA C22.2 No. 18.4
- UL File Number: E216996



CATALOG #	DESCRIPTION	WEIGHT EACH (LBS.)
RSCBS12316	Universal Clamp Back Spacer 1/2 Inch - 1 Inch 316	0.11

PARALLEL CLAMPS

Stainless



DESCRIPTION

Robroy Stainless Parallel Clamps are made from 316 stainless steel and are designed for use with rigid or PVC-coated conduit to run pipe or conduit parallel to the flange of I-beams or channel simply and easily without drilling holes.

STANDARDS

- cULus Listed
- UL 2239
- UL File Number: E216996

CATALOG #	DESCRIPTION	WEIGHT EACH (LBS.)
RSPAR216	Parallel Clamp 3/4 Inch 316	0.56
RSPAR316	Parallel Clamp 1 Inch 316	0.58

Stainless Steel Accessories

LOCKNUTS

Stainless



DESCRIPTION

Robroy Stainless Locknuts are made from 316 stainless steel and are used to connect and secure threaded rigid conduit to an enclosure or outlet box.

STANDARDS

- cULus Listed
- UL 514B
- UL File Number: E200413

CATALOG #	DESCRIPTION	WEIGHT EACH (LBS.)
RSLN116	Locknut 1/2 Inch 316	0.01
RSLN216	Locknut 3/4 Inch 316	0.02
RSLN316	Locknut 1 Inch 316	0.03
RSLN416	Locknut 1-1/4 Inch 316	0.04
RSLN516	Locknut 1-1/2 Inch 316	0.05
RSLN616	Locknut 2 Inch 316	0.06

CONDUIT HANGERS

Stainless



DESCRIPTION

Robroy Stainless Conduit Hangers are designed to be used with threaded rod, beam clamps, etc. to suspend rigid or PVC-coated conduit from I-beams, flanges, etc. All conduit hangers are made from 316 stainless steel and come with a 316 stainless steel bolt and nut.

STANDARDS

- cULus Listed
- UL 2239
- UL File Number: E216996

CATALOG #	DESCRIPTION	WEIGHT EACH (LBS.)
RSCH116	Conduit Hanger 1/2 Inch 316	0.06
RSCH216	Conduit Hanger 3/4 Inch 316	0.06
RSCH316	Conduit Hanger 1 Inch 316	0.10
RSCH416	Conduit Hanger 1-1/4 Inch 316	0.11
RSCH516	Conduit Hanger 1-1/2 Inch 316	0.16
RSCH616	Conduit Hanger 2 Inch 316	0.18
RSCH716	Conduit Hanger 2-1/2 Inch 316	0.25
RSCH816	Conduit Hanger 3 Inch 316	0.29
RSCH1016	Conduit Hanger 4 Inch 316	0.35

ALL THREAD ROD

Stainless



DESCRIPTION

Robroy Stainless All Thread Rod is used as a fastening or supporting means in electrical and mechanical installations in industrial facilities – inside or outside - where corrosion is a concern. Typical uses include overhead and trapeze mounting with conduit and pipe hangers, beam clamps, strut, and split ring hangers.

CATALOG #	DESCRIPTION	WEIGHT EACH (LBS.)
RSATR304063/8	3/8 Inch x 6 Foot 304 ATR Hanger Rod	1.875
RSATR304123/8	3/8 Inch x 12 Foot 304 ATR Hanger Rod	3.75
RSATR304061/2	1/2 Inch x 6 Foot 304 ATR Hanger Rod	3.36
RSATR304121/2	1/2 Inch x 12 Foot 304 ATR Hanger Rod	6.72

BEAM CLAMPS

Stainless



DESCRIPTION

Robroy Stainless Beam Clamps are made from 316 stainless steel and are designed for use on I-beams, channel, and other structural members and are used for hanging conduit or cables. Attachment holes are located on the back and bottom.

CATALOG #	DESCRIPTION	MAX BEAM FLANGE (IN.)	WEIGHT EACH (LBS.)	DESIGN LOAD (LBS.)
RSBC116	Beam Clamp for 1/4 Inch -20 Threaded Rod	0.75	0.25	150
RSBC216	Beam Clamp for 3/8 Inch -16 Threaded Rod	1	0.80	750
RSBC316	Beam Clamp 1/2 Inch -13 Threaded Rod	1	1.48	1100

SLOTTED STRUTS

Stainless



DESCRIPTION

Robroy Stainless Slotted Strut is available in 304 or 316 stainless steel and provides framework and support for conduit systems. The slotted hole design allows for fastening at various points.

CATALOG #	DESCRIPTION	WEIGHT EACH (LBS.)
RSA-4PLH-304X10	Slotted Strut 7/8 Inch 304	10.00
RSA-1PLH-304X10	Slotted Strut 1-5/8 Inch 304	19.00
RSA-4PLH-316X10	Slotted Strut 7/8 Inch 316	10.00
RSA-1PLH-316X10	Slotted Strut 1-5/8 Inch 316	19.00

BACK TO BACK SLOTTED STRUTS

Stainless



DESCRIPTION

Robroy Stainless Back to Back Slotted Strut is available in 304 or 316 stainless steel and provides framework and support for conduit systems. The slotted hole design allows for fastening at various points.

CATALOG #	DESCRIPTION	WEIGHT EACH (LBS.)
RSA-1201PLH-304X10	Back To Back Slotted Strut 1-5/8 Inch 304	38.00
RSA-1201PLH-316X10	Back To Back Slotted Strut 1-5/8 Inch 316	38.00

Stainless Steel Accessories

RIGID STRUT STRAPS

Stainless



DESCRIPTION

Robroy Stainless Rigid Strut Straps are designed to be used with strut in order to secure a conduit run. Robroy Stainless Rigid Strut Straps are available in 316 stainless steel.

CATALOG #	DESCRIPTION	WEIGHT EACH (LBS.)
RSP-1050-316	Rigid Strut Straps 1/2 Inch 316	1.05
RSP-1075-316	Rigid Strut Straps 3/4 Inch 316	1.45
RSP-1100-316	Rigid Strut Straps 1 Inch 316	1.65
RSP-1125-316	Rigid Strut Straps 1-1/4 Inch 316	1.90
RSP-1150-316	Rigid Strut Straps 1-1/2 Inch 316	3.00
RSP-1200-316	Rigid Strut Straps 2 Inch 316	3.30
RSP-1250-316	Rigid Strut Straps 2-1/2 Inch 316	3.90
RSP-1300-316	Rigid Strut Straps 3 Inch 316	4.40
RSP-1400-316	Rigid Strut Straps 4 Inch 316	6.20

BRACKETS

Stainless

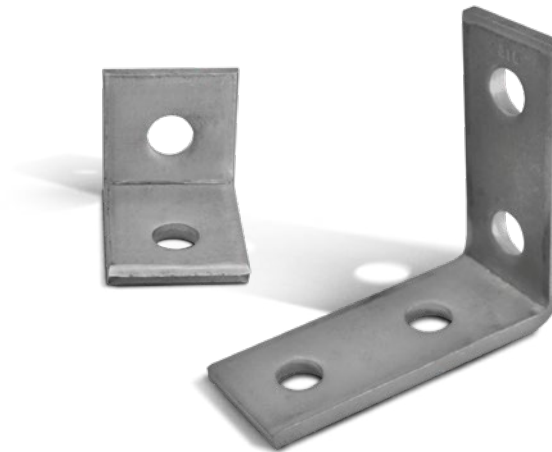

DESCRIPTION

Robroy Stainless Brackets are used to connect stainless steel strut. They are constructed of 316 stainless steel and hole size is 3/16".

CATALOG #	DESCRIPTION	WEIGHT EACH (LBS.)
RSF-2202-316	2 Hole Bracket 316	0.40
RSF-2407-316	4 Hole Angle Bracket 316	0.84

STRUT NUT WITH SPRINGS

Stainless



DESCRIPTION

Robroy Stainless Strut Nuts with Spring help secure components in a strut system and are available in 316 stainless steel.

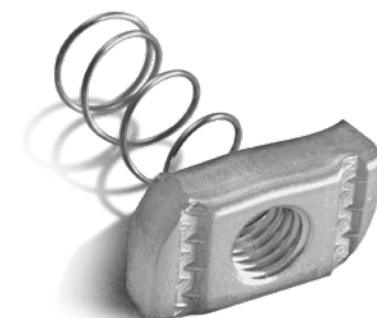

CATALOG #	DESCRIPTION	WEIGHT EACH (LBS.)
RSSN-1025-316	1/4 Inch Strut Nut with Spring 316	0.10
RSSN-1037-316	3/8 Inch Strut Nut with Spring 316	0.10
RSSN-1050-316	1/2 Inch Strut Nut with Spring 316	0.10

FLAT ANGLES

Stainless



DESCRIPTION

Robroy Stainless Flat Plates are used to connect sections of channel strut together in vertical or horizontal sections forming a splice joint. Robroy Stainless Flat Plates are 316 stainless steel and hole size is 3/16".

CATALOG #	DESCRIPTION	WEIGHT EACH (LBS.)
RSF-1301-316	3 Hole Flat Angle Plate 316	0.58
RSF-1406-A-316	4 Hole Flat Angle Plate 316	0.80

Stainless Steel Accessories

FLAT SQUARE WASHERS

Stainless



DESCRIPTION

Robroy Stainless Flat Square Washers are 316 stainless steel and are designed for use with strut in order to make connections within the system or act as a spacer, shim or seat for various hardware components.

CATALOG #	DESCRIPTION	WEIGHT EACH (LBS.)
RSF-1101-1/2-316	Flat Square Washer 1/2 Inch 316	0.19

BASE PLATES

Stainless

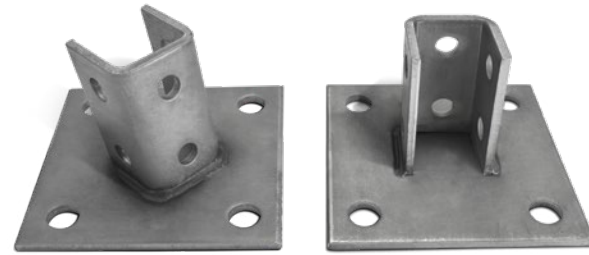

DESCRIPTION

Robroy Stainless Base Plates are designed to be floor mounted to support upright strut installations. They are available in 316 stainless steel and hole size is 3/16".

CATALOG #	DESCRIPTION	WEIGHT EACH (LBS.)
RSF-9601-316	Channel Base Plate 316	3.27
RSF-9601-SQ-316	Square Channel Base Plate 316	3.27

FLAT PLATES

Stainless

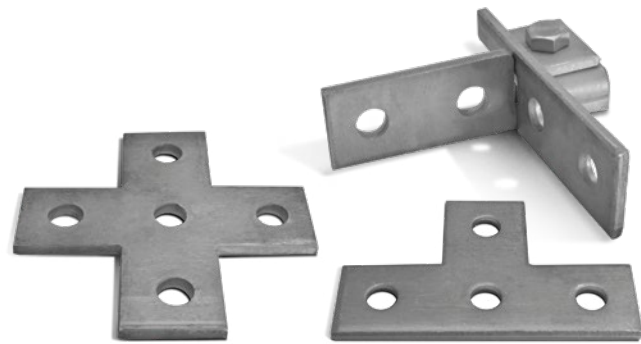

DESCRIPTION

Robroy Stainless Flat Plates are 316 stainless steel and are used to connect sections of channel strut together in vertical or horizontal sections forming a splice joint. Robroy Stainless Flat Plates are 316 stainless steel and hole size is 3/16".

CATALOG #	DESCRIPTION	WEIGHT EACH (LBS.)
RSF-1401-316	4 Hole T Plate 316	0.83
RSF-1402-316	4 Hole Splice Plate 316	0.77
RSF-1501-316	5 Hole Cross Plate 316	1.05

Installation Tools

SPIN-IT

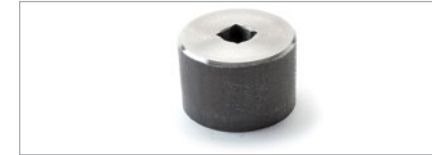

With the Spin-It, Perma-Cote can be tightened much faster than with conventional tools. Because the Spin-It never touches the coating, damage to the conduit is eliminated.

CATALOG #	DESCRIPTION
PMSPIN-IT-3/4	3/4" Spin-It
PMSPIN-IT-1	1" Spin-It
PMSPIN-IT-1-1/4	1-1/4" Spin-It
PMSPIN-IT-1-1/2	1-1/2" Spin-It
PMSPIN-IT-2	2" Spin-It

JAWS 3



JAWS 3 are a set of aluminum-nickel-bronze vise jaws designed to replace the regular jaws in a RIGID #23 or #40-A pipe vise. They completely protect the exterior coating from damage caused by the vise jaws when cutting or threading.

CATALOG #	DESCRIPTION
PMJAWS3-#23	JAWS3 #23 Bench Mount Pipe Vise
PMJAWS3-#40-A	JAWS3 #40-A Tripod Pipe Vise

PVC COATING REPAIR KIT



The PVC Coating Repair Kit is a UL recognized two-part epoxy capable of bonding to PVC and steel or aluminum substrates. It includes all necessary tools in order to repair the damaged area and is dark gray in color.

CATALOG #	DESCRIPTION
PMPVCREPAIR-KIT	PVC Coating Repair Kit

PLASTI-SOCKET



Plasti-Socket is a plastic encapsulated 3/8" drive socket for use with the square encapsulated U-Bolt and beam clamp nuts used in the Perma-Cote conduit support system. The Plasti-Socket helps avoid coating damage from metal sockets, pliers, or wrenches.

CATALOG #	DESCRIPTION
PMPLASTISOCKET-3/8	3/8" Plasti-Socket

HALF-SHELL CLAMPS



Half-Shell Clamps are designed to cover a large surface area when clamping conduit, especially in a chain vise. This allows for a strong grip without damaging the exterior coating.

CATALOG #	DESCRIPTION
PMHLF-SHL-CLP2	2" Half-Shell Conduit Clamp
PMHLF-SHL-CLP2-1/2	2-1/2" Half-Shell Conduit Clamp
PMHLF-SHL-CLP3	3" Half-Shell Conduit Clamp
PMHLF-SHL-CLP3-1/2	3-1/2" Half-Shell Conduit Clamp
PMHLF-SHL-CLP4	4" Half-Shell Conduit Clamp
PMHLF-SHL-CLP5	5" Half-Shell Conduit Clamp
PMHLF-SHL-CLP6	6" Half-Shell Conduit Clamp

ROD STRIPPING TOOL



Robroy Stainless Rod stripping tool is used to safely and efficiently strip the coating from Rocket Rod or PVC coated all thread rod exposing the desired length of exposed rod required for installation.

CATALOG #	DESCRIPTION
RSRST12	1/2" Rod Stripping Tool
RSRST38	3/8" Rod Stripping Tool

Z-WRENCH



Z-Wrench features extra wide jaws that spread the clamping force, enabling the tool to grip without marring the surface of the conduit. The "V" shaped upper jaw allows Z-Wrench to accommodate a wide range of conduit sizes. Shallow grooves in the upper and lower jaws provide an excellent grip.

CATALOG #	DESCRIPTION
PMJPZ1	1/2" - 1-1/4" Z-Wrench
PMJPZ2	1-1/2" - 2-1/2" Z-Wrench

HICKEY



The Perma-Cote Hickey is a special bending tool with a 40 mil PVC coating which reduces the possibility of damage during conduit bending.

CATALOG #	DESCRIPTION
PMHICKEY	1/2" & 3/4" Conduit Bender

TOUCH-UP COMPOUNDS



Perma-Cote Touch-up Compounds are available to repair minor damage to the interior urethane or exterior PVC factory coatings. The exterior PVC touch-up compound is gray and available in a 12 oz. aerosol can and a pint can with brush-top applicator. The approved thread compound is available in a pint can with a brush-top applicator.

CATALOG #	DESCRIPTION	SIZE
PMTC-1700	Exterior Spray Type (Gray)	12 oz.
PMTC-1600	Exterior Non-Spray with Brush-Top (Gray)	1 pt.
PMTHREAD-COMPOUND	Approved Conductive Compound-Brush-Top Pint	1 pt.

Perma-Cote is a system providing the best available exterior and interior protection against corrosion. Proper installation is essential to ensure the best possible service life for a conduit system. To ensure the best possible PVC-coated conduit installation, it is recommended that installers are certified.

Qualified installation provides these benefits:

- **The End User...**
...receives optimum installation quality and best possible service life.
- **The Professional...**
...benefits because of obvious concern for providing only the best to the end-user.
- **The Contractor...**
...achieves more cost-effective installation.

Everyone benefits!

Perma-Cote Installer Certification is based upon training that includes classroom and hands-on instruction encompassing:

- Proper installation techniques and tools
- Hands-on instruction for clamping, cutting, threading, bending, and assembly of PVC-coated conduit
- Interactive discussion of techniques and troubleshooting

Only installers who are able to present valid, unexpired credentials of having passed our instruction and examination are officially certified to install Perma-Cotes's top quality products.

Installer certification is free of charge and available at the job site, contractor's shop, factory, or wherever it is convenient to you! For more information about Installer Certification, contact Perma-Cote at (903) 843-4388.

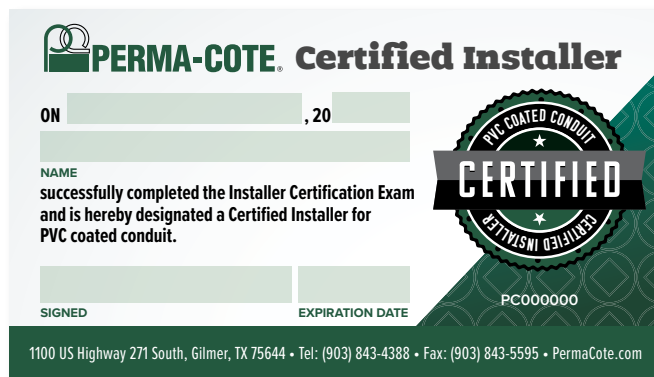
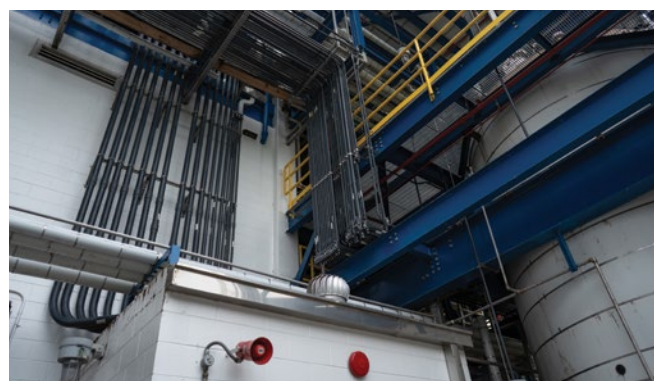

LOWER YOUR PROJECT RISKS AND COSTS

LATEST INFORMATION ON NEW PVC-COATED PRODUCTS

Our customers trust in the long-term value of our products because their facilities are safely and effectively protected against corrosion and/or contamination. The investment of our customers in our products is best realized by meaningful education. Therefore, we market ourselves through accredited educational programs that provide the knowledge base required for our customers to reach their own conclusions about how and why our products meet their application needs. Our extensive education and training programs mitigate risks and reduce costs by helping ensure proper system design and product installation.



CORROSION PROTECTION AND SAFETY ASSURANCE

ACCREDITED

For End Users, Engineers
Accreditation/Certification: 1 PDH engineering credit

PRODUCT PERFORMANCE VERIFICATION FOR CORROSIVE ENVIRONMENTS

ACCREDITED

For End Users, Engineers
Accreditation/Certification: 1 PDH engineering credit

PVC-COATED INNOVATION

For End Users, Engineers, Inspectors, Installers
Latest info on new products

INSTALLER CERTIFICATION

CERTIFIED

For Inspectors, Installers
Certification: Certified PVC-Coated Installer

SCHEDULE YOUR COURSE TODAY.

Email: lwhite@robroy.com

Phone: (903) 843-5591

Technical Information

URETHANE INTERIOR COATING CHEMICAL RESISTANCE CHART

SOLUTIONS	CONC.	TEMP.	RECOMMENDED EXPOSURE		
			FUMES	SPLASH	IMMERSION
Acetic Acid	10%	75° F	YES	YES	NO
Acid Copper Plating Sol.	Any	75° F	YES	YES	NO
Alkaline Cleaners	Any	75° F	YES	YES	NO
Aluminum Chloride	Sat'd	75° F	YES	YES	NO
Aluminum Sulfate	Sat'd	75° F	YES	YES	NO
Alums	Sat'd	75° F	YES	YES	NO
Ammonium Chloride	Sat'd	75° F	YES	YES	NO
Ammonium Hydroxide	28%	75° F	YES	YES	NO
Ammonium Hydroxide	10%	75° F	YES	YES	NO
Ammonium Sulfate	Sat'd	75° F	YES	YES	NO
Ammonium Thiocyanate	Sat'd	75° F	YES	YES	NO
Amyl Alcohol	Sat'd	75° F	YES	YES	YES
Arsenic Acids	Any	75° F	YES	YES	NO
Barium Sulfide	Sat'd	75° F	YES	YES	NO
Black Liquor	Sat'd	75° F	YES	YES	NO
Benzoic Acid	Sat'd	75° F	YES	YES	NO
Brass Plating Solution	Sat'd	75° F	YES	YES	NO
Bromine Water	Sat'd	75° F	YES	YES	NO
Butyl Alcohol	Any	75° F	YES	YES	NO
Cadmium Plating Sol.	Any	75° F	YES	YES	NO
Cadmium Bisulfate	Any	75° F	YES	YES	NO
Calcium Chloride	Sat'd	75° F	YES	YES	NO
Calcium Hypochlorite	Sat'd	75° F	YES	YES	NO
Carbonic Acid	Sat'd	75° F	YES	YES	NO
Casein	Any	75° F	YES	YES	NO
Castor Oil	Any	75° F	YES	YES	YES
Caustic Soda	35%	75° F	YES	YES	NO
Caustic Soda	10%	75° F	YES	YES	NO
Caustic Potash	35%	75° F	YES	YES	NO
Caustic Potash	10%	75° F	YES	YES	NO
Chlorine Water	Sat'd	75° F	YES	YES	NO
Chromium Plating Sol.	Any	75° F	YES	YES	NO
Citric Acid	Sat'd	75° F	YES	YES	NO
Copper Chloride	Sat'd	75° F	YES	YES	NO
Copper Cyanide Plating Sol.	Any	75° F	YES	YES	NO
Copper Sulfate	Sat'd	75° F	YES	YES	NO
Coconut Oil	Sat'd	75° F	YES	YES	YES
Cottonseed Oil	Sat'd	75° F	YES	YES	YES
Disodium Phosphate	Sat'd	75° F	YES	YES	NO
Ethyl Alcohol	Any	75° F	YES	YES	NO
Ethylene Glycol	Any	75° F	YES	YES	YES
Ferrous Sulfate	Sat'd	75° F	YES	YES	NO
Fluoboric Acid	Any	75° F	YES	YES	NO
Formaldehyde	37%	75° F	YES	YES	NO
Formic Acid	85%	75° F	YES	YES	NO
Gallic Acid	Sat'd	75° F	YES	YES	NO
Glucose	Any	75° F	YES	YES	YES
Glycerine	Any	75° F	YES	YES	YES
Gold Plating Solution	Any	75° F	YES	YES	NO
Hydrochloric Acid	10%	75° F	YES	YES	NO
Hydrochloric Acid	21.5%	75° F	YES	YES	NO
Hydrochloric Acid	37.5%	75° F	YES	YES	NO
Hydrofluoric Acid	4%	75° F	YES	YES	NO
Hydrofluoric Acid	10%	75° F	YES	YES	NO
Hydrofluoric Acid	48%	75° F	YES	YES	NO
Hydrogen Peroxide	30%	75° F	YES	YES	NO
Hydroquinone	Any	75° F	YES	YES	NO
Indium Plating Solution	Any	75° F	YES	YES	NO
Lactic Acid	Any	75° F	YES	YES	NO
Lead Plating Solution	Any	75° F	YES	YES	NO

SOLUTIONS	CONC.	TEMP.	RECOMMENDED EXPOSURE		
			FUMES	SPLASH	IMMERSION
Malic Acid	Any	75° F	YES	YES	NO
Methyl Alcohol	Any	75° F	YES	YES	NO
Mineral Oils	Any	75° F	YES	YES	YES
Nickel Acetate	Sat'd	75° F	YES	YES	NO
Nickel Plating Solution	Any	75° F	YES	YES	NO
Nickel Salts	Sat'd	75° F	YES	YES	NO
Nitric Acid	35%	75° F	YES	YES	NO
Nitric Acid	40%	75° F	YES	YES	NO
Nitric Acid	60%	75° F	YES	YES	NO
Nitric/Hydrofluoric Acid	15%/4%	75° F	YES	YES	NO
Nitric Acid/ Sodium Dichromate Water	16%/13%/71%	75° F	YES	YES	NO
Oleic Acid	Any	75° F	YES	YES	NO
Oxalic Acid	Any	75° F	YES	YES	NO
Phenol	Sat'd	75° F	YES	YES	NO
Phosphoric Acid	75%	75° F	YES	YES	NO
Phosphoric Acid	85%	75° F	YES	YES	NO
Potassium Acid Sulfate	Sat'd	75° F	YES	YES	NO
Potassium Antimonate	Sat'd	75° F	YES	YES	NO
Potassium Bisulfite	Sat'd	75° F	YES	YES	NO
Potassium Chloride	Sat'd	75° F	YES	YES	NO
Potassium Cuprocyanide	Sat'd	75° F	YES	YES	NO
Potassium Cyanide	Sat'd	75° F	YES	YES	NO
Potassium Dichromate	Sat'd	75° F	YES	YES	NO
Potassium Hypochlorate	Sat'd	75° F	YES	YES	NO
Potassium Sulfide	Sat'd	75° F	YES	YES	NO
Potassium Thiosulfate	Sat'd	75° F	YES	YES	NO
Propyl Alcohol	Sat'd	75° F	YES	YES	NO
Rhodium Plating Solution	Sat'd	75° F	YES	YES	NO
Silver Plating Solution	Sat'd	75° F	YES	YES	NO
Soaps	Any	75° F	YES	YES	NO
Sodium Acid Sulfate	Sat'd	75° F	YES	YES	NO
Sodium Antimonate	Sat'd	75° F	YES	YES	NO
Sodium Bicarbonate	Sat'd	75° F	YES	YES	NO
Sodium Bisulfite	Sat'd	75° F	YES	YES	NO
Sodium Chloride	Sat'd	75° F	YES	YES	NO
Sodium Cyanide	Sat'd	75° F	YES	YES	NO
Sodium Dichromate	Sat'd	75° F	YES	YES	NO
Sodium Hydroxide	10%	75° F	YES	YES	NO
Sodium Hydroxide	35%	75° F	YES	YES	NO
Sodium Hydroxide	73%	75° F	YES	YES	NO
Sodium Hypochlorite	Sat'd	75° F	YES	YES	NO
Sodium Hypochlorite	15%	75° F	YES	YES	NO
Sodium Sulfide	Sat'd	75° F	YES	YES	NO
Sodium Thiosulfate	Sat'd	75° F	YES	YES	NO
Sulfuric Acid	15%	75° F	YES	YES	NO
Sulfuric Acid	50%	75° F	YES	YES	NO
Sulfuric Acid	70%	75° F	YES	YES	NO
Sulfuric Acid	98%	75° F	YES	YES	NO
Sulfurous Acid	2%	75° F	YES	YES	NO
Sulfurous Acid	4%	75° F	YES	YES	NO
Tannic Acid	Sat'd	75° F	YES	YES	NO
Tartaric Acid	Sat'd	75° F	YES	YES	NO
Tin Chloride	Sat'd	75° F	YES	YES	NO
Tin Plating Solution	Sat'd	75° F	YES	YES	NO
Triethanolamine	Sat'd	75° F	YES	YES	NO
Trisodium Phosphate	Sat'd	75° F	YES	YES	NO
White Liquor	Sat'd	75° F	YES	YES	NO
Zinc Plating Solution	Sat'd	75° F	YES	YES	NO
Zinc Sulfate	Sat'd	75° F	YES	YES	NO

PVC EXTERIOR COATING CHEMICAL RESISTANCE CHART

SOLUTIONS	CONC.	TEMP.	RECOMMENDED EXPOSURE		
			FUMES	SPLASH	IMMERSION
Acetic Acid	10%	120	NO	NO	NO
Acid Copper Plating Sol.	Any	160	YES	YES	YES
Alkaline Cleaners	Any	160	YES	YES	YES
Aluminum Chloride	Sat'd	160	YES	YES	YES
Aluminum Sulfate	Sat'd	160	YES	YES	YES
Alums	Sat'd	160	YES	YES	YES
Ammonium Chloride	Sat'd	160	YES	YES	YES
Ammonium Hydroxide	28%	120	YES	YES	YES
Ammonium Hydroxide	10%	120	YES	YES	YES
Ammonium Sulfate	Sat'd	160	YES	YES	YES
Ammonium Thiocyanate	Sat'd	160	YES	YES	YES
Amyl Alcohol	Any	90	YES	YES	YES
Arsenic Acids	Any	150	YES	YES	YES
Barium Sulfide	Sat'd	160	YES	YES	YES
Black Liquor	Sat'd	90	YES	YES	YES
Benzoic Acid	Sat'd	160	YES	YES	YES
Brass Plating Solution	Any	160	YES	YES	YES
Bromine Water	Sat'd	120	YES	YES	YES
Butyl Alcohol	Any	90	YES	YES	YES
Cadmium Plating Sol.	Any	150	YES	YES	YES
Cadmium Bisulfate	Any	150	YES	YES	YES
Calcium Chloride	Sat'd	160	YES	YES	YES
Calcium Hypochlorite	Sat'd	120	YES	YES	YES
Carbonic Acid	Sat'd	160	YES	YES	YES
Casein	Any	90	YES	YES	YES
Castor Oil	Any	90	YES	YES	YES
Caustic Soda	35%	120	YES	YES	YES
Caustic Soda	10%	150	YES	YES	YES
Caustic Potash	35%	120	YES	YES	YES
Caustic Potash	10%	150	YES	YES	YES
Chlorine Water	Sat'd	90	YES	YES	YES
Chromium Plating Sol.	Any	150	YES	YES	YES
Citric Acid	Sat'd	160	YES	YES	YES
Copper Chloride	Sat'd	160	YES	YES	YES
Copper Cyanide Plating Sol.	Any	160	YES	YES	YES
(High Speed)	Any	180	YES	YES	YES
(with Alkali Cyanides)	Sat'd	160	YES	YES	YES
Copper Sulfate	Sat'd	160	YES	YES	YES
Coconut Oil	Sat'd	90	YES	YES	YES
Cottonseed Oil	Sat'd	90	YES	YES	YES
Disodium Phosphate	Sat'd	160	YES	YES	YES
Ethyl Alcohol	Any	90	YES	YES	YES
Ethylene Glycol	Any	90	YES	YES	NO
Ferric Chloride	45%	120	YES	YES	YES
Ferrous Sulfate	Sat'd	150	YES	YES	YES
Fluoboric Acid	Any	150	YES	YES	YES
Formaldehyde	37%	120	YES	YES	YES
Formic Acid	85%	100	NO	NO	NO
Gallic Acid	Sat'd	150	YES	NO	NO
Glucose	Any	150	YES	YES	YES
Glycerine	Any	90	YES	YES	YES
Gold Plating Solution	Any	150	YES	YES	YES
Hydrochloric Acid	10%	120	YES	YES	YES
Hydrochloric Acid	21.5%	120	YES	YES	YES
Hydrochloric Acid	37.5%	120	YES	YES	NO
Hydrochloric Acid	37.5%	90	YES	YES	NO
Hydrofluoric Acid	4%	140	YES	YES	NO
Hydrofluoric Acid	10%	120	YES	YES	NO
Hydrofluoric Acid	48%	120	YES	YES	NO
Hydrogen Peroxide	30%	120	YES	YES	YES
Hydrogen Sulfide	Sat'd	120	YES	YES	YES
Hydroquinone	Any	90	YES	YES	YES
Indium Plating Solution	Any	150	YES	YES	YES

SOLUTIONS	CONC.	TEMP.	RECOMMENDED EXPOSURE		
			FUMES	SPLASH	IMMERSION
Lactic Acid	50%	120	YES	YES	YES
Lactic Acid	Any	90	YES	YES	YES
Lead Plating Solution	Any	150	YES	YES	YES
Malic Acid	Any	90	YES	YES	YES
Methyl Alcohol	Any	90	YES	YES	YES
Mineral Oils	Any	90	YES	YES	YES
Nickel Acetate	Sat'd	160	YES	YES	YES
Nickel Plating Solution	Any	160	YES	YES	YES
Nickel Salts	Sat'd	160	YES	YES	YES
Nitric Acid	35%	120	YES	YES	NO
Nitric Acid	40%	90	YES	YES	NO
Nitric Acid	60%	120	YES	YES	NO
Nitric/Hydrofluoric Acid	15%/4%	140	YES	YES	YES
Nitric Acid/ Sodium Dichromate Water	16%/13%/71%	130	YES	YES	YES
Oleic Acid	Any	90	YES	YES	YES
Oxalic Acid	Any	90	YES	YES	YES
Phenol	Sat'd	120	NO	NO	NO
Phosphoric Acid	75%	150	YES	YES	YES
Phosphoric Acid	85%	120	YES	YES	YES
Potassium Acid Sulfate	Sat'd	150	YES	YES	YES
Potassium Antimonate	Sat'd	150	YES	YES	YES
Potassium Bisulfite	Sat'd	90	YES	YES	YES
Potassium Chloride	Sat'd	160	YES	YES	YES
Potassium Cuprocyanide	Sat'd	150	YES	YES	YES
Potassium Cyanide	Sat'd	160	YES	YES	YES
Potassium Dichromate	Sat'd	160	YES	YES	YES
Potassium Hypochlorate	Sat'd	90	YES	YES	YES
Potassium Sulfide	Sat'd	150	YES	YES	YES
Potassium Thiosulfate	Sat'd	150	YES	YES	YES
Propyl Alcohol	Sat'd	150	YES	YES	YES
Rhodium Plating Solution	Sat'd	150	YES	YES	YES
Silver Plating Solution	Sat'd	150	YES	YES	YES
Soaps	Any	90	YES	YES	YES
Sodium Acid Sulfate	Sat'd	160	YES	YES	YES
Sodium Antimonate	Sat'd	150	YES	YES	YES
Sodium Bicarbonate	Sat'd	160	YES	YES	YES
Sodium Bisulfite	Sat'd	90	YES	YES	YES
Sodium Chloride	Sat'd	160	YES	YES	YES
Sodium Cyanide	Sat'd	160	YES	YES	YES
Sodium Dichromate	Sat'd	160	YES	YES	YES
Sodium Hydroxide	10%	150	YES	YES	NO
Sodium Hydroxide	35%	120	YES	YES	NO
Sodium Hydroxide	73%	160	NO	NO	NO
Sodium Hypochlorite	Sat'd	90	YES	YES	NO
Sodium Hypochlorite	15%	120	YES	YES	NO
Sodium Sulfide	Sat'd	150	YES	YES	YES
Sodium Thiosulfate	Sat'd	150	YES	YES	YES
Sulfuric Acid	15%	120	YES	YES	YES
Sulfuric Acid	50%	120	YES	YES	YES
Sulfuric Acid	70%	90	YES	YES	NO
Sulfuric Acid	98%	100	YES	NO	NO
Sulfurous Acid	2%	120	YES	YES	NO
Sulfurous Acid	6%	120	YES	YES	NO
Tannic Acid	Sat'd	90	YES	YES	YES
Tartaric Acid	Sat'd	90	YES	YES	YES
Tin Chloride	Sat'd	150	YES	YES	YES
Tin Plating Solution	Sat'd	150	YES	YES	YES
Triethanolamine	Sat'd	150	YES	YES	YES
Trisodium Phosphate	Sat'd	150	YES	YES	YES
White Liquor	Sat'd	90	YES	YES	YES
Zinc Plating Solution	Sat'd	160	YES	YES	YES
Zinc Sulfate	Sat'd	160	YES	YES	YES

PERMA-COTE PERFORMANCE STANDARDS/DESCRIPTIONS

Exterior PVC and interior urethane coating performance shall be confirmed by the characteristics and tests listed below. Test samples shall be selected at random.

FLAMMABILITY

The PVC coating will burn if subjected to sustained flame or heat above 400°F, however, it will self extinguish upon removal of the heat source or flame.

TOXICITY

Prolonged exposure to heat greater than 200°F or exposure to fire may cause the PVC coating to release harmful emissions that could pose a potential health hazard. Therefore, PVC use is not recommended in areas exposed to sustained temperatures above 200°F. If exposed to fire, particularly in closed areas, users should be aware and observe proper caution.

BOIL TEST

Acceptable conduit coating bonds shall be confirmed if there is no disbondment after a minimum average of 200 hours in boiling water or exposure to steam vapor at one atmosphere. The periodic increments between bond tests shall not exceed 5 hours for the first 25 hours, then it may be lengthened by mutual consent. The RNI Bond Test and the Standard Method for Measuring Adhesion by Tape Test shall be utilized.

Exterior Adhesion

A 6"-length of conduit test specimen shall be placed in boiling water. The specimen shall be periodically removed, cooled to ambient temperature and immediately tested according to the bond test (RNI). When the PVC coating separates from the substrate, the boil time to failure in hours shall be recorded. ASTM D870 describes this test method for accelerated testing of coating adhesive bonds.

Interior Adhesion

6" conduit test specimen shall be cut in half longitudinally and placed in boiling water or directly above boiling water with the urethane surface facing down. The specimen shall be periodically removed, cooled to ambient temperature,

and tested in accordance with the Standard Method of Adhesion by Tape Test (ASTM D3359). When the coating disbonds, the time to failure in hours shall be recorded.

HEAT/HUMIDITY TEST

Acceptable conduit coating bonds shall be confirmed by a minimum average of 30 days in the Heat and Humidity Test. The periodic increment between bond tests shall not exceed 5 days for the first 30 days, then may be lengthened by mutual consent. The RNI Bond Test and the Standard Method for Measuring Adhesion by Tape Test shall be utilized.

Exterior Adhesion

Conduit specimens shall be placed in a heat and humidity environment where the temperature is maintained at 150°F (66°C) and 95% relative humidity. The specimens shall be periodically removed and a bond test (RNI) performed. When the PVC coating separates from the substrate, the exposure time to failure in days shall be recorded. ASTM D1151, D1735, D2247, and D4585 are the basis for this accelerated method of evaluating adhesive bonding.

Interior Adhesion

The conditions for interior adhesion testing of conduit specimens are the same as those for external adhesion. ASTM D3359 is used to determine adhesive failure.

ETL VERIFIED PVC-001

The PVC coating adhesion performance of this product has been ETL verified to the Intertek ETL SEMKO High Temperature H2O PVC-Coating Adhesion Test Procedure for 200 hours.

CHEMICAL RESISTANCE TEST

No trace of the internal coating shall be visible on a white cloth following six wipes over the coating that has been wetted with acetone (ASTM D1308).

POLYURETHANE

The supplier shall confirm that the internal coating that meets the above condition is a polyurethane.

Perma-Cote has used the American Society for Testing and Materials (ASTM) standards to provide comparable and consistent test data. A list of ASTM standards referenced in the Perma-Cote Coated Conduit Specification appears below.

ASTM B1117

Standard Practice for Operating Salt Spray (Fog) Apparatus

ASTM D149

Test Methods for Dielectric Breakdown Voltage and Dielectric Strength of Solid Electrical Insulating Materials at Commercial Power Frequencies

ASTM D638

Test Method for Tensile Properties of Plastics

ASTM D746

Test Method for Brittleness Temperature of Plastics and Elastomers by Impact

ASTM D870

Method for Water Immersion Test of Organic Coatings on Steel

ASTM D1151

Test Method for Effect of Moisture and Temperature on Adhesive Bonds

ASTM D1654

Standard Test Method for Evaluation of Painted or Coated Specimens Subjected to Corrosive Environments

ASTM D1735

Method for Water Fog Testing of Organic Coatings

ASTM D2240

Test Method for Rubber Property-Durometer Hardness

ASTM D2247

Method of Testing Coated Metal Specimens at 100% Relative Humidity

ASTM D2444

Standard Test Method for Determination of the Impact Resistance of Thermoplastic Pipe and Fittings by Means of a Tup (Falling Weight)

ASTM D3359

Method for Measuring Adhesion by Tape Test

ASTM D4585

Testing Water Resistance of Coatings Using Controlled Condensation

ASTM D1308

Effect of Chemicals on Clear and Pigmented Organic Finishes

ASTM G153

Standard Practice for Operating Enclosed Carbon Arc Light Apparatus for Exposure of Non-Metallic Materials

ASTM G155

Standard Practice for Operating Xenon Arc Light Apparatus for Exposure of Non-Metallic Materials



ROBROY
INDUSTRIES
LEADING THE WAY

 **PERMA-COTE**®

1100 US Highway 271 South
Gilmer, TX 75644
Phone: (903) 843-4388
Fax: (903) 843-5595
Sales Fax: (903) 680-4259

CSR@Robroy.com

ISO
9001:2015
CERTIFIED

Perma-Cote PVC-Coating galvanized rigid conduit and fittings provide unequalled corrosion protection. Manufactured in the U.S.A., ISO 9001-certified Perma-Cote complies with all standards mandated by UL 6, UL 1203, NEMA RN-1, and ANSI C80.1. In addition, Perma-Cote is ETL Verified for product performance and reliable longevity ten or more times longer than brands that are not ETL Verified. Look for the combined ETL/UL label to be sure you are receiving the protection you've paid for.

© 2022 Robroy Industries
Effective Date: 04/2022
Order Item: PM-114