



# Gardner-Denver® Pneumatic Hoists

 **COOPER** Tools



Model Number Index . . . . .	2-3
ISO-9001 . . . . .	4
Warranty, Lubrication, Safety . . . . .	5
Hoist Introduction/Overview . . . . .	6-8
Selecting the Proper Hoist . . . . .	9
<b>Hook Mounted Hoists</b>	
<b>Rotary Vane Hoists</b>	
7 Series . . . . .	11
K5 Series . . . . .	12-13
K1 Series . . . . .	14-15
<b>Axial Piston Hoists</b>	
P1 Series . . . . .	16-17
P2 Series . . . . .	18-19
P3 Series . . . . .	20-21
Trolleys for Hook Mounted Hoists . . . . .	22
<b>Lug Mounted Hoists</b>	
<b>Rotary Vane Hoists</b>	
K5 Series . . . . .	24-25
<b>Axial Piston Hoists</b>	
P1 Series . . . . .	26-27
Trolleys for Lug Mounted Hoists . . . . .	28
<b>Trolley Mounted Hoists</b>	
<b>Rotary Vane Hoists</b>	
K5 Series . . . . .	30-31
K1 Series . . . . .	32-33
<b>Axial Piston Hoists</b>	
P1 Series . . . . .	34-35
P2 Series . . . . .	36-37
P3 Series . . . . .	38-39
<b>Hoist/Hoisttractor</b>	
Hoisttractor Overview . . . . .	40-41
TA Series . . . . .	42-43
<b>Hoist/Hoisttractor Combination Units</b>	
<b>Rotary Vane Hoists</b>	
K1 Series . . . . .	44-45
<b>Axial Piston Hoists</b>	
P2 Series . . . . .	46-47
P3 Series . . . . .	48-49
<b>Hoist/Hoisttractor Combination Units (Low Headroom)</b>	
<b>Axial Piston Hoists</b>	
P3 Series . . . . .	50-51
<b>Accessories &amp; Replacement Parts . . . . .</b>	
<b>52-59</b>	
“I” Beam Specifications . . . . .	53
Chain containers . . . . .	54
Hooks . . . . .	56
Pendent controls . . . . .	58
Chain . . . . .	58
<b>General Information . . . . .</b>	
<b>52-59</b>	
Training . . . . .	60
Sales & Service Centers . . . . .	62
Cooper Tools on the web . . . . .	63
Catalogs . . . . .	64

# Model Number Index

MODEL NUMBER	PAGE	MODEL NUMBER	PAGE	MODEL NUMBER	PAGE
<b>7 Series</b>					
75250AC5.....	11	K5HA22RRER010CGA22 .....	13	P1TA03LREL010AAA03.....	35
<b>K1 Series</b>		K5LA05LPEL010AAA05.....	25	P1TA05LPEL010AAA05.....	35
K1CA22LPEP010AAA22 .....	45	K5LA05LREL010AAA05 .....	25	P1TA05LREL010AAA05.....	35
K1CA33LPEP010AAA33 .....	45	K5LA11LPEL010AAA11.....	25	P1TA10LPEL010AAA10.....	35
K1CA44LPEP010AAA44 .....	45	K5LA11LREL010AAA11 .....	25	P1TA10LREL010AAA10.....	35
K1CA6 6LPEP010GCA66 .....	45	K5LA22LPEL010BEA22.....	25	P1HA04RREN010CCA05.....	17
K1CA88LPEP010GCA88.....	45	K5LA22LREL010BEA22 .....	25	P1HA09RPEN010CCA10.....	17
K1HA22LPEP010AAA22 .....	15	K5TA05LPEL010AAA05.....	31	P1HA09RREN010CCA10.....	17
K1HA22LREP010AAA22 .....	15	K5TA05LREL010AAA05.....	31	P1LA03LPEL010AAA03 .....	27
K1HA33LPEP010AAA33 .....	15	K5TA11LPEL010AAA11.....	31	P1LA03LREL010AAA03 .....	27
K1HA33LREP010AAA33 .....	15	K5TA11LREL010AAA11.....	31	P1LA05LPEL010AAA05 .....	27
K1HA44LPEP010AAA44 .....	15	K5TA22LPEL010ACA22.....	31	P1LA05LREL010AAA05 .....	27
K1HA44LREP010AAA44 .....	15	K5TA22LREL010ACA22 .....	31	P1LA10LPEL010AAA10 .....	27
K1HA66LPEP010CCA66.....	15	<b>P1 Series</b>		P1LA10LREL010AAA10 .....	27
K1HA66LREP010CCA66.....	15	P1HA03LPEL010AAA03 .....	17	P1LA20LPEL010BHA20.....	27
K1HA88LPEP010CCA88.....	15	P1HA03LREL010AAA03 .....	17	P1LA20LREL010BHA20.....	27
K1HA88LREP010CCA88.....	15	P1HA03RPER010AGA03.....	17	P1TA03LPEL010AAA03 .....	35
K1TA22LPEP010AAA22 .....	33	P1HA03RRER010AGA03 .....	17	P1TA03LREL010AAA03 .....	35
K1TA22LREP010AAA22 .....	33	P1HA04RPEN010CCA05 .....	17	P1TA05LPEL010AAA05 .....	35
K1TA33LPEP010AAA33 .....	33	P1HA04RREN010CCA05 .....	17	P1TA05LREL010AAA05 .....	35
K1TA33LREP010AAA33 .....	33	P1HA05LPEL010AAA05 .....	17	P1TA10LPEL010AAA10 .....	35
K1TA44LPEP010AAA44 .....	33	P1HA05LREL010AAA05 .....	17	P1TA10LREL010AAA10 .....	35
K1TA44LREP010AAA44 .....	33	P1HA05RPER010AGA05.....	17	<b>P2 Series</b>	
K1TA66LPEP010BCA66 .....	33	P1HA05RRER010AGA05 .....	17	P2CA11LPEL010AAA11 .....	47
K1TA66LREP010BCA66 .....	33	P1HA09RPEN010CCA10 .....	17	P2CA15LPEQ010CCA15.....	47
K1TA88LPEP010BCA88 .....	33	P1HA09RREN010CCA10 .....	17	P2CA22LPEL010AAA22 .....	47
K1TA88LREP010BCA88 .....	33	P1HA10LPEL010AAA10 .....	17	P2CA30LPEQ010CEA30.....	47
<b>K5 Series</b>		P1HA10LREL010AAA10 .....	17	P2CA44LPEL010AGA44 .....	47
K5HA05LPEL010AAA05 .....	13	P1HA10RPEP010AGA10.....	17	P2HA10LPEQ010CCA10.....	19
K5HA05LREL010AAA05 .....	13	P1HA10RRER010AGA10 .....	17	P2HA10LREQ010CCA10.....	19
K5HA05RPER010ACA05.....	13	P1HA20LPEL010EHA20 .....	17	P2HA11LPEL010AAA11 .....	19
K5HA05RRER010ACA05.....	13	P1HA20LREL010EHA20 .....	17	P2HA11LREL010AAA11 .....	19
K5HA11LPEL010AAA11 .....	13	P1LA03LPEL010AAA03.....	27	P2HA11RPER010AKA11.....	19
K5HA11LREL010AAA11 .....	13	P1LA03LREL010AAA03 .....	27	P2HA11RRER010AKA11.....	19
K5HA11RPER010ACA11.....	13	P1LA05LPEL010AAA05.....	27	P2HA15LPEQ010CCA15.....	19
K5HA11RRER010ACA11.....	13	P1LA05LREL010AAA05 .....	27	P2HA15LREQ010CCA15.....	19
K5HA22LPEL010CEA22 .....	13	P1LA10LPEL010AAA10.....	27	P2HA22LPEL010AAA22 .....	19
K5HA22LREL010CEA22 .....	13	P1LA10LREL010AAA10 .....	27	P2HA22LREL010AAA22 .....	19
K5HA22RPER010CGA22 .....	13	P1LA20LPEL010BHA20 .....	27	P2HA22RPER010AKA22.....	19
		P1LA20LREL010BHA20 .....	27	P2HA22RRER010AKA22.....	19
		P1TA03LPEL010AAA03.....	35	P2HA30LPEQ010EEA30 .....	19





Cooper Tools Division has attained ISO 9001 Quality System Certification for seven of our facilities. The driving force behind the implementation of the Quality System is the commitment "to provide our customers with the **best value delivered** by offering only products and services **that meet or exceed their expectations**".



Lexington, South Carolina



Dayton, Ohio



Hicksville, Ohio



Springfield, Ohio



Braunschweig, Germany



Westhausen, Germany



Ozoir-la-Ferrière, France

## Warranty

Cooper warrants products and parts sold by it, insofar as they are of its own manufacture, against defects of material and workmanship, under normal use and service in accordance with its written instructions, recommendations, and ratings for installation, operation, maintenance, and service of products, for a period of **ONE YEAR FROM THE DATE OF INITIAL USE, BUT IN NO EVENT SHALL THE WARRANTY EXCEED 24 MONTHS FROM DATE OF DELIVERY TO DISTRIBUTOR.** Proof of Purchase with shipment date must be furnished by the user to validate the warranty. This warranty applies only to products manufactured by Cooper and specifically excludes products manufactured by others. Products not manufactured by Cooper are warranted only to the extent and in the manner warranted to Cooper by the manufacturer

and then only to the extent Cooper is able to enforce such warranty. Cooper's warranty with respect to products manufactured by it is limited to the repair or replacement, as Cooper may elect, of any defective part regarding which the Distributor has given 5 days written notice from the discovery of such defect. Installation and transportation costs are not included. Cooper shall have the option of requiring the return to it of the defective material, transportation prepaid, for inspection. No allowance will be made for repairs without Cooper's approval. **COOPER MAKES NO OTHER WARRANTY OF ANY KIND WHATSOEVER, EXPRESSED OR IMPLIED, AND HEREBY DISCLAIMS ALL WARRANTIES OF MERCHANTABILITY AND FITNESS FOR A PARTICULAR PURPOSE.**

## Lubrication Products

Cooper Tools' products are classified as non-hazardous manufactured items, defined in the OSHA 1910.1200 Hazard Communication Standard as "Articles". These products, under conditions of normal use, do not release or cause exposure to a hazardous chemical.

Under normal conditions of use, lubrication products sold separately for or used within these tools should not cause an exposure hazard. Refer to the Material Safety Data Sheet (M.S.D.S.) for Safety and Disposal Information. M.S.D.S. sheets are available upon request from Cooper Tools.

Cooper is also aware of, and complies with, the

provisions of section 611 amendments to the Clean Air Act of 1990. No ozone depleting chemicals have been used in the manufacture of our products.

If you resell or distribute these products, you have the responsibility for ensuring that the Material Safety Data Sheets are provided to the purchaser.

Proper lubrication is essential to the economical operation of pneumatic and electric tools. Cooper Tools perform better and their life is extended by using the recommended lubricants. All lubricants that are listed in the accessory section of this catalog have undergone extensive testing and are recommended for use with Cooper Tools products.



# Pneumatic Hoist Introduction

## Tools of the highest quality

Gardner-Denver hoists are engineered to provide high productivity for virtually limitless applications. Each and every hoist is rigorously tested before it is shipped, plus the manufacturing processes of Cooper Tools are ISO 9001 certified, so you can be sure that every Gardner-Denver hoist is manufactured to the highest standards.

## Hoists that are flexible

The wide range of hoists that are available from Gardner-Denver means that every application requirement can be suited. Because of the limitless combinations of power, speed, weight, size, mounting, and materials – your hoist becomes as flexible in its application solutions as you need it to be.

## Hoists of superior design

All our hoists are engineered to very high tolerances to ensure smooth running and long life. The option of the axial piston motor (made only by Gardner-Denver) offers an extra standard of performance. Using less air than a rotary vane motor, the axial piston design adds high torque and smooth operation to a hoist that is powerful, relatively small, compact, economical and quiet. Another example of high quality engineering from Gardner-Denver, designed to improve your efficiency.



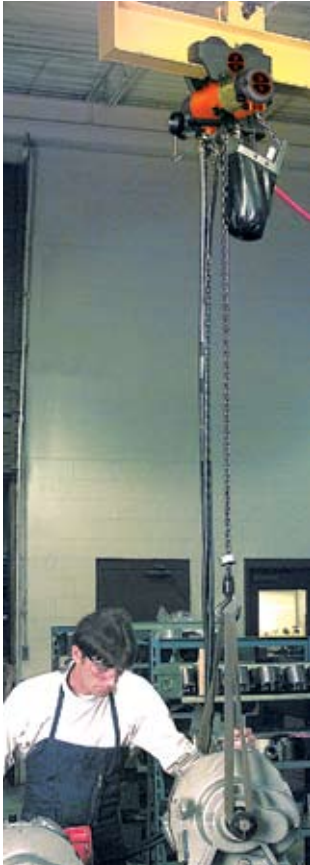

## Advantages of air hoists....

When compared to electric hoists, Gardner-Denver air hoists offer many advantages in speed, weight, simplicity, spark resistance, and their ability to operate in adverse conditions.

The speed of an air hoist is continually variable, allowing greater application flexibility. The weight can be 40% to 50% less, offering easier installation and greater portability, and because of design simplicity, air hoists do not require skilled repair technicians.

Air hoists do not create an electrical arc, are

inherently spark-resistant, and do not pose a risk of electric shock if the operator is standing in water, or if the control cord is damaged. In addition, they have a much greater resistance to weather, dampness, dirt, dust, steam and corrosive fumes, and have a longer duty cycle, higher temperature tolerance, and do not require costly surge protectors in the event of a brownout.

Together with these advantages, the Gardner-Denver Air Hoist is a very well engineered unit designed and tested to provide long, trouble-free operation.

## Spark resistant and clean room hoists

Gardner-Denver spark resistant hoists featuring stainless steel chain and bronze upper and lower hooks, and trolleys featuring rubber bumpers and bronze wheels, are ideal for use in paint booths, grain elevators, munitions factories, and chemical tanks. With the addition of edible grease and a piped exhaust adapter, they can be used in clean room applications such as food processing, pharmaceuticals and textile environments.

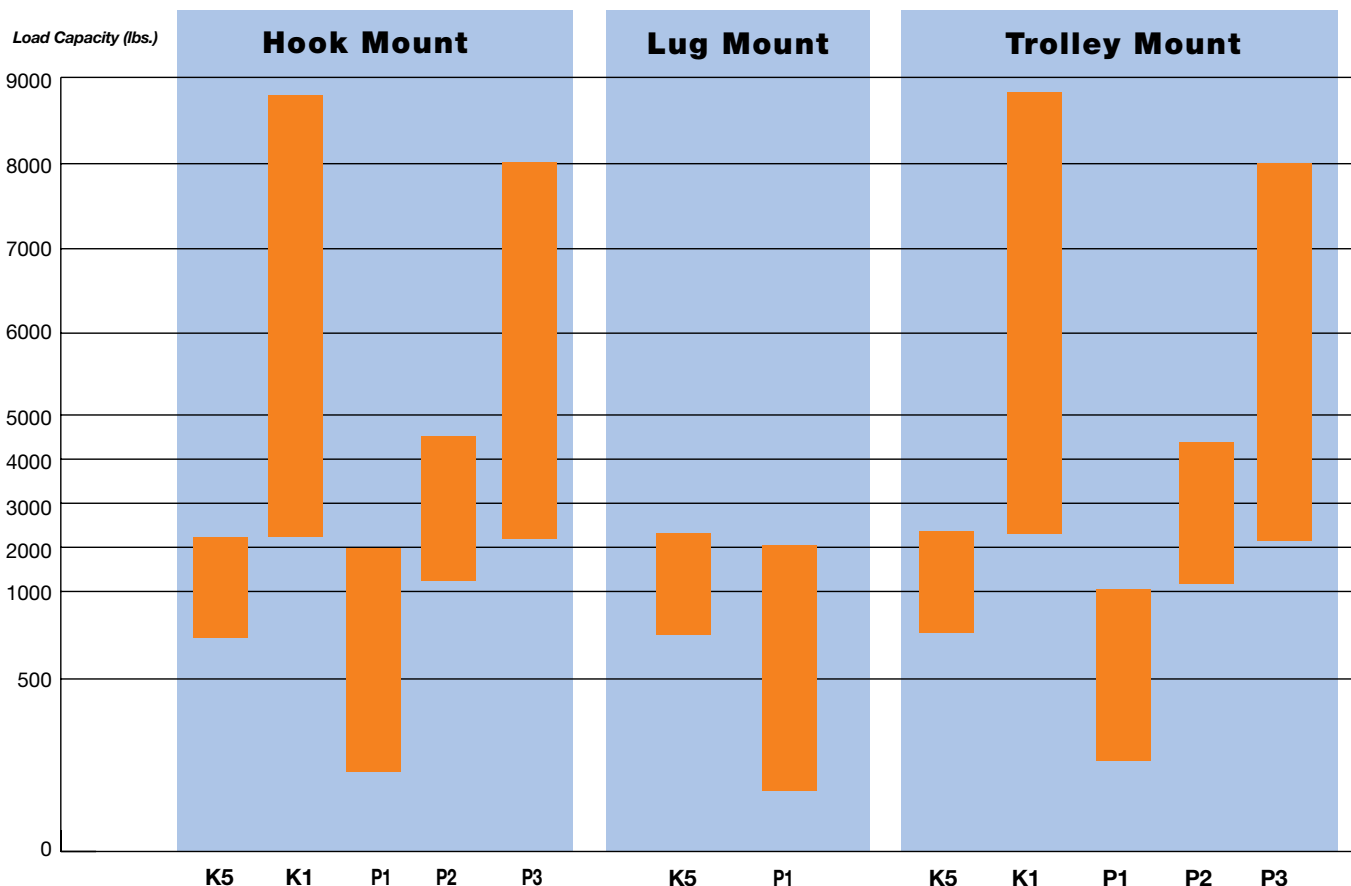



# Pneumatic Hoist Overview

Fueled by endless numbers of varying applications, and the desire to provide greater flexibility, Gardner-Denver offers an extensive list of hoist options, and accessories. As you begin to define the hoist configuration which best suits your unique application, utilize the criteria outlined here to obtain the optimum operator/hoist/task relationship.

## Mounting Options



### ■ Hook Mount

Although requiring more headroom than lug mounts, the flexibility of hook mounted hoists make them the more popular choice. Easier to hang and relocate, hook mounted hoists rotate at both the upper and lower hooks, allowing the operator greater flexibility when manipulating a load into a desired position or angle. In addition, many hook mounted hoists offer the option of link or roller chain, and when hung from the appropriate Gardner-Denver trolley, allow horizontal movement of the load.

### ■ Lug Mount

The compact, low headroom design of lug mounted hoists make them ideal for applications where space is at a premium. This semi-permanent mount provides the greatest benefits in tight working situations where the non-rotating, non-swinging lug allows precise placement of the load. Lug mounted hoists are available with link chain only, to allow side movement of the load, and can be mounted on the appropriate Gardner-Denver trolley for horizontal movement of the load.



### ■ Trolley Mount

For semi-permanent applications requiring horizontal load movement, trolley mounted hoists provide the greatest benefits. This compact, non-rotating configuration holds the load in constant alignment, as ball bearing constructed wheels provide smooth movement along the beam. Gardner-Denver trolleys adapt to many "I" beam sizes and are offered in link chain only, to allow side movement of the load.

## Motor Options

### ■ Rotary Vane

The industry standard in air hoists, rotary vane motors provide an economical, easy to maintain solution for the majority of fast, rugged applications. The Gardner-Denver 7, K5, and K1 series of easy to operate hoists incorporate rotary vane motors which can be removed without disturbing brakes, valving, or gearing, while highly reliable spring loaded vanes insure immediate response start after start.



### ■ Axial Piston *(Manufactured exclusively by Gardner-Denver)*

For applications where precise load control is essential, Gardner-Denver offers the P1, P2, and P3 series of axial piston hoists. These motors operate using multiple air driven pistons providing axial force; this force is converted to rotary motion through the use of a socket plate and driveshaft assembly, all within a small, compact package. Axial piston motors provide several advantages including precise load control, quiet operation, low air consumption, and greater resistance to adverse air conditions.



## Control Options



### ■ Rope

Rope control provides a simple, direct link to the hoist control valve, allowing the operator to "feather" the operation of the hoist, making starts and stops more accurate and predictable. Because there are no moving parts, rope controls require minimum maintenance and are economical to replace.

### ■ Pendant

Gardner-Denver hoist control pendants provide a versatile, one-handed method of hoist control. With varying length options, the operator can safely control both lifting and lowering of the hoist as well as horizontal movement of a hoist tractor, from 5 to 25 ft away. With the required cable assembly, the pendant control provides a means for pulling a trolley, and the ergonomic handle design provides operator comfort while preventing accidental operation.



## Chain Options

### ■ Link

Link chain, with its relatively low cost, is available on all hoist models, and is practical for use in a wide variety of applications. Its capacity for rotation allows the operator to rotate the load slightly to assist with precise placement. For applications requiring rust and spark resistance, Gardner-Denver offers zinc plated chain on all models of hoists, and stainless steel chain on hoists with capacities up to 3000 lbs.



### ■ Roller

For smoother operation and extended life, Gardner-Denver offers roller chain on the K5, P1, and P2 series of hook mounted hoists. In addition, roller chain manufactured with stainless steel is available for applications requiring spark resistant or clean room operation.



## Single or Double Reeved

### ■ Single Reeved

When speed is of more importance than capacity, the single reeved hoist is the best choice. Through the direct connection of the lower hook to the chain, and then to the hoist, all available drive speed is transferred to the load.



### ■ Double Reeved

For extra lifting capacity, the double reeved configuration increases the amount of weight the motor can lift. By routing the chain around a sprocket on the lower hook before connecting it to the hoist drive, lifting capacity is doubled. In turn, the speed of the lift is reduced by half. For heavy and sensitive loads, this slower action could be preferable.



## General Hoist Selection

### Hoist Mounting (page 8):

- Hook (pages 11-21)    Lug (pages 23-28)    Trolley (pages 29-39)  
 Hoistactor (pages 40-43)    Hoist/Hoistactor Combination Units (pages 44-51)

### Hoist Motor Type (page 8):

- Rotary Vane    Axial Piston

### Capacity Requirement (see appropriate hoist page):

### Control Type (page 8):

- Rope:       Standard 5 feet      \_\_\_\_\_ Specify optional length  
Pendent:    Standard 5 feet      \_\_\_\_\_ Specify optional length

### Chain Type (page 8):

- Link       Roller       Spark Resistant

### Lift (see appropriate Hoist page):

- Standard 10 feet      \_\_\_\_\_ Specify optional length      \_\_\_\_\_ Lifting speed

### Hook Type: (optional hooks, page 56)

- Upper:       Standard       Bullard  
Lower:       Standard       Bullard

## Trolley Mounted Hoists, Hoistactors & Combination Units

### Beam Specifications (page 53):

\_\_\_\_\_ Width \_\_\_\_\_ Height

### Wheel Type:

- Trolley (pages 29-39):       Tapered (Standard)    Flat    Narrow Flat\*  
Hoistactor (page 42-43):       Tapered (Standard)    Flat    Narrow Flat\*  
Hoist/Hoistactor Comb. Unit (pages 44-51):       Tapered (Standard)    Flat    Narrow Flat\*

\*NOTE: Suitable for American Std., American Monorail, Cleveland Tramrail, Spanmaster, Whiting, and Loudon patented "I" beams

### Hoistactor Engagement (page 40):

- Spring (Standard)       Free Wheel to Positive Drive       Positive Drive to Free Wheel

### Hoistactor Engaging Wheel Type (page 42):

- Neoprene (Standard)       Adiprene

## Extra Equipment

- Chain Container (Pg. 54-55)    Auxiliary Cable (Pg. 57)    Hose Trolley    Piped Exhaust Adapter    Flow Control Valve (Pg. 57)

# Hook Mounted Hoists

## Introduction

Gardner-Denver hook mounted hoists are designed to provide the ultimate in high strength and flexibility. Hook mounted hoists can quickly be hung from virtually any structure including trolleys, and their portability make them ideal for maintenance applications or on construction sites. Ball bearing constructed upper and lower hooks allow full 360° rotation of the hoist and load for precision load placement, while optional roller chain, available exclusively on hook mounted hoists, provides longer chain life and smoother lifting and lowering motion. With load lifting capacities ranging from 275 to 8800 lbs., choice of rotary vane or axial piston configurations, and many spark resistant options, matching one of these industrial grade hoists to your shop or clean room application will not be a problem.

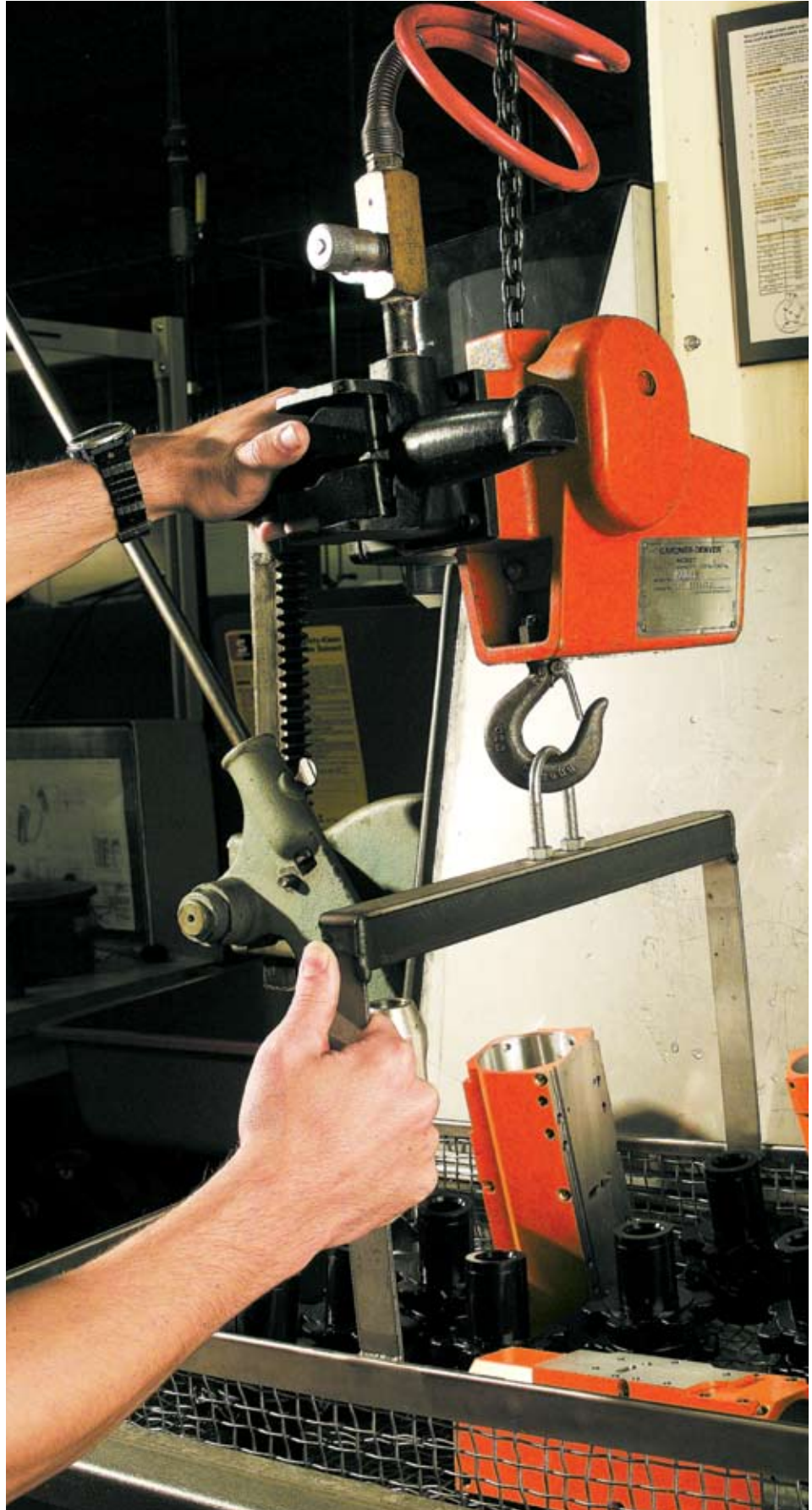





## GARDNER-DENVER®

### 7 Series

**Capacity:**  
275 lbs. 125 kg

- **Compact, Lightweight Design** makes the 7 series the ideal portable, plug-n-go hoists.
- **Self-Cooling, Self-Adjusting Disc Brake** provides smooth stops and starts through 8 ft. of lift.
- **Conveniently Positioned Thumb Controls** allow right or left hand operation.

The smooth running Gardner-Denver 7 series hoists feature a built in chain container and load capacity up to 275 lbs., making this lightweight (only 24 lbs), compact hoist the perfect solution for an endless number of light duty, low lift height applications. Often found on loading docks, in shipping or receiving areas, or mounted above parts washers or tooling fixtures, this simple to use, portable hoist provides an economical solution for increasing worker productivity.

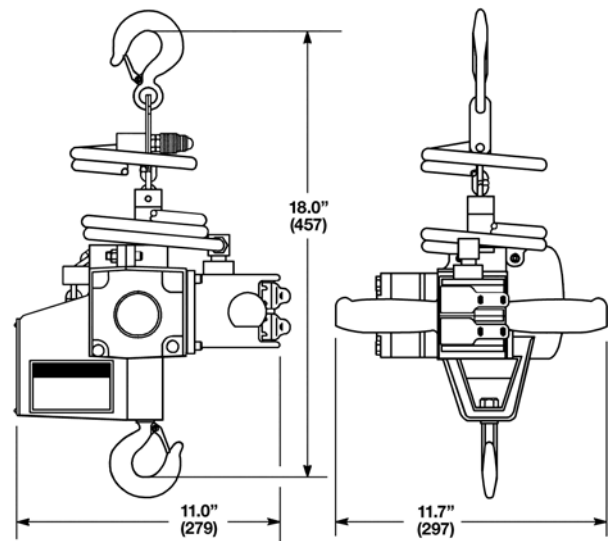

Model Number	Chain Type	Capacity		Lifting & Lowering Speeds				Lift Distance		Weight	
				Maximum Lift		Maximum Lower					
Unit Mounted Control		lbs.	kg	fpm	mpm	fpm	mpm	ft	m	lbs.	kg
75250AC5	Link	275	125	38	12	60	18	8.0	2.4	24	11

**General:**

Air Inlet: 3/8" NPT (use 1/2" I.D. Hose)  
Performance rated at 90 psig (6 bar/620 kPa).  
Air Consumption 40 cfm (1.13m<sup>3</sup>/min.) at rated load.

**Standard Equipment:**

Hook mounted air hoist with built-in chain container

**Extra Equipment:**

Trolley – page 22  
Air strainer intake fitting – A9P1450

# Hook Mounted Hoists

K5 Series

## GARDNER-DENVER®

### K5 Series

Capacity:

550-2200 lbs. 250-1000 kg

- Rotary Vane Air Motor
- Rope or Pendant Control
- Link or Roller Chain



**Single Reeved**  
550 lbs. (250 kg) & 1100 lbs.  
(500 kg) Capacity

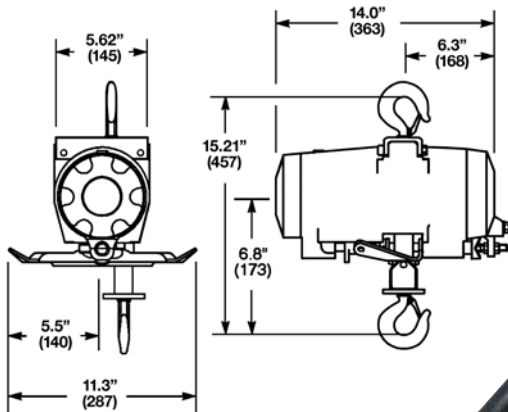

**Double Reeved**  
2200 lbs. (1000 kg) Capacity

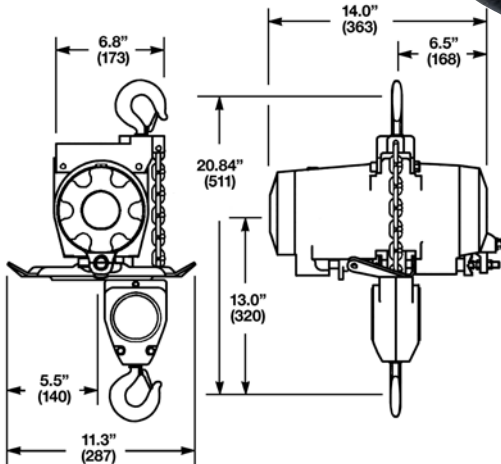

**K5 H A 05 L P E L --- A A A 05**

**SERIES**

**K5**

**TYPE MOUNT**

H = Hook

**FEATURES**

A = Standard Unit  
H = Hi Temp Grease  
P = Epoxy Paint  
S = Epoxy Paint/Hi Temp Grease

**CAPACITY**

05 = 550 lbs.  
11 = 1100 lbs.  
22 = 2200 lbs.

**CHAIN TYPE**

L = Link  
R = Roller

**CONTROL TYPE**

P = Pendant (Standard-2LVR)  
R = Rope  
W = None-Pendant Ready  
X = None

**CONTROL LENGTH**

E = 5 FT      T = 20 FT  
J = 10 FT     Y = 25 FT  
O = 15 FT     Z = None

**CHAIN OPTIONS**

L = Link  
R = Standard Roller  
X = No Chain

**CAPACITY RATING**

05 = 550 lbs. (05)  
06 = 550 lbs. (22)  
11 = 1100 lbs. (11)  
12 = 1100 lbs. (22)  
22 = 2200 lbs. (22)

**VINTAGE**

A

**LOWER HOOK**

A = Standard Link (05/11)  
B = Bullard Link (05/11)  
C = Standard Roller (05/11)  
D = Bullard Roller (05/11)  
E = Standard Link (22)  
F = Bullard Link (22)  
G = Standard Roller (22)  
H = Bullard Roller (22)  
X = No Hook

**UPPER HOOK**

A = Standard (05/11)  
B = Bullard (05/11)  
C = Standard (22)  
D = Bullard (22)  
X = No Hook

**AMOUNT OF LIFT**

--- Specify Length in Feet, 3 digits  
Example: 10' lift 010

Note: Numbers in parentheses following an option, represent the hoist capacities for which that option is available.

Model Number		Chain Type	Capacity		Lifting & Lowering Speeds				Reeves	Weight	
Pendant Control	Rope Control		lbs.	kg	Lifting		Lowering			lbs.	kg
					fpm	mpm	fpm	mpm			
K5HA05LPEL010AAA05	K5HA05LREL010AAA05	Link	550	250	40-67	12-20	110-147	33-44	1	42	19
K5HA05RPER010ACA05	K5HA05RRER010ACA05	Roller	550	250	40-67	12-20	110-147	33-44	1	42	19
K5HA11LPEL010AAA11	K5HA11LREL010AAA11	Link	1100	500	20-50	6-15	80-120	24-36	1	42	19
K5HA11RPER010ACA11	K5HA11RRER010ACA11	Roller	1100	500	20-50	6-15	80-120	24-36	1	42	19
K5HA22LPEL010CEA22	K5HA22LREL010CEA22	Link	2200	1000	10-25	3-7	40-60	12-18	2	54	25
K5HA22RPER010CGA22	K5HA22RRER010CGA22	Roller	2200	1000	10-25	3-7	40-60	12-18	2	54	25

**General:**

Air Inlet: 1/2" NPT (use 3/4" I.D. Hose)  
Performance rated at 90 psig (6.2 bar/620 kPa) air pressure.  
Air Consumption 75 cfm (2.12m<sup>3</sup>/min.) at rated load.

**Standard Equipment:**

Hook mounted air hoist with 10 ft. (3.0m) lift  
Rope Control: 5 ft. (1.5m) rope length  
Pendant Control: 5 ft. (1.5m) hose length

**Extra Equipment:**

Chain container – page 54-55  
Hoist trolleys – page 22  
Auxiliary cable (Backup suspension) – page 57  
Air strainer intake fitting – A10161  
Piped exhaust adapter (3/4"NPT) – 536567



# Hook Mounted Hoists

K1 Series

## GARDNER-DENVER®

### K1 Series

Capacity:

2200-8800 lbs. 1000-4000 kg

- Rotary Vane Air Motor
- Rope or Pendant Control
- Link Chain

**Single Reeved**  
2200 lbs. (1000 kg), 3300 lbs. (1500 kg)  
& 4400 lbs. (2000 kg) Capacity

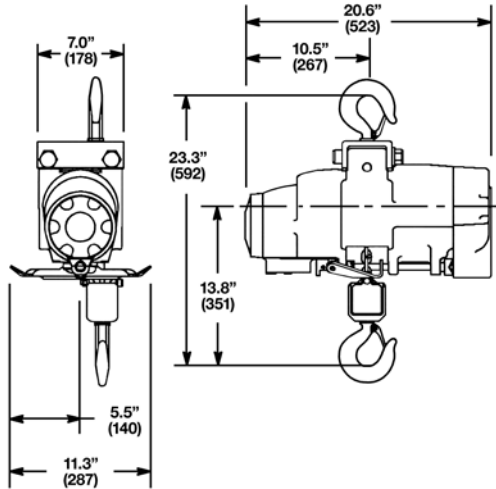

**Double Reeved**  
6600 lbs. (3000 kg) & 8800 lbs.  
(4000 kg) Capacity

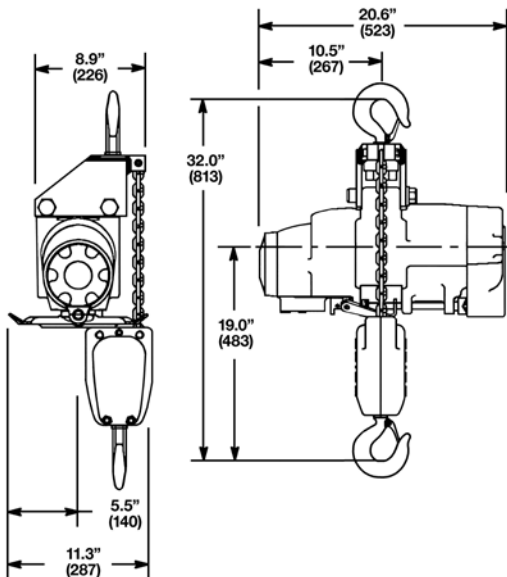

**K1 H A 22 L P E P --- A A A 22**

**SERIES**

K1

**TYPE MOUNT**

H = Hook

**FEATURES**

A = Standard Unit  
 H = Hi Temp Grease  
 P = Epoxy Paint  
 S = Epoxy Paint/Hi Temp Grease

**CAPACITY**

22 = 2200 lbs.      66 = 6600 lbs.  
 33 = 3300 lbs.      88 = 8800 lbs.  
 44 = 4400 lbs.

**CHAIN TYPE**

L = Link

**CONTROL TYPE**

P = Pendent (Standard-2LVR)  
 R = Rope  
 W = None-Pendent Ready  
 X = None

**CONTROL LENGTH**

E = 5 FT      T = 20 FT  
 J = 10 FT      Y = 25 FT  
 O = 15 FT      Z = None

**CHAIN OPTIONS**

P = Zinc Plated Link  
 X = No Chain

**CAPACITY RATING**

11 = 1100 lbs. (11/22/33/44)  
 22 = 2200 lbs. (22/33/44)  
 33 = 3300 lbs. (33/44)  
 34 = 3300 lbs. (66)  
 44 = 4400 lbs. (44)  
 45 = 4400 lbs. (66/88)  
 66 = 6600 lbs. (66)  
 88 = 8800 lbs. (88)

**VINTAGE**

A

**LOWER HOOK**

A = Standard Link (22/33/44)  
 B = Bullard Link (22/33/44)  
 C = Standard Link (66/88)  
 D = Bullard Link (66/88)  
 X = No Hook

**UPPER HOOK**

A = Standard (22/33/44)  
 B = Bullard (22/33/44)  
 C = Standard (66/88)  
 D = Bullard (66/88)  
 X = No Hook

**AMOUNT OF LIFT**

--- Specify Length in Feet, 3 digits

Example: 10' lift 010

Note: Numbers in parentheses following an option, represent the hoist capacities for which that option is available.

Model Number		Chain Type	Capacity		Lifting & Lowering Speeds				Reeves	Weight	
Pendent Control	Rope Control		lbs.	kg	Maximum Lift		Maximum Lower			lbs.	kg
					fpm	mpm	fpm	mpm			
K1HA22LPEP010AAA22	K1HA22LREP010AAA22	Link	2200	1000	33	10	52	16	1	107	49
K1HA33LPEP010AAA33	K1HA33LREP010AAA33	Link	3300	1500	21	6	34	10	1	107	49
K1HA44LPEP010AAA44	K1HA44LREP010AAA44	Link	4400	2000	15	5	24	7	1	107	49
K1HA66LPEP010CCA66	K1HA66LREP010CCA66	Link	6600	3000	10	3	17	5	2	130	59
K1HA88LPEP010CCA88	K1HA88LREP010CCA88	Link	8800	4000	7	2	12	4	2	130	59

**General:**

Air Inlet: 1/2" NPT (use 3/4" I.D. Hose)  
 Performance rated at 90 psig (6 bar/620 kPa) air pressure.  
 Air Consumption 75 cfm (2.12m<sup>3</sup>/min.) at rated load.

**Standard Equipment:**

Hook mounted air hoist with 10 ft. (3.0m) lift  
 Rope Control: 5 ft. (1.5m) rope length  
 Pendent Control: 5 ft. (1.5m) hose length

**Extra Equipment:**

Chain container – page 54-55  
 Hoist trolleys – page 22  
 Auxiliary cable (Backup suspension) – page 57  
 Piped exhaust adapter (3/4" NPT) – 536567  
 Tractor connection kit – 516710

# Hook Mounted Hoists

P1 Series

## GARDNER-DENVER®

### P1 Series

Capacity:

300-2000 lbs. 136-907 kg

- Axial Piston Air Motor
- Rope or Pendant Control
- Link or Roller Chain

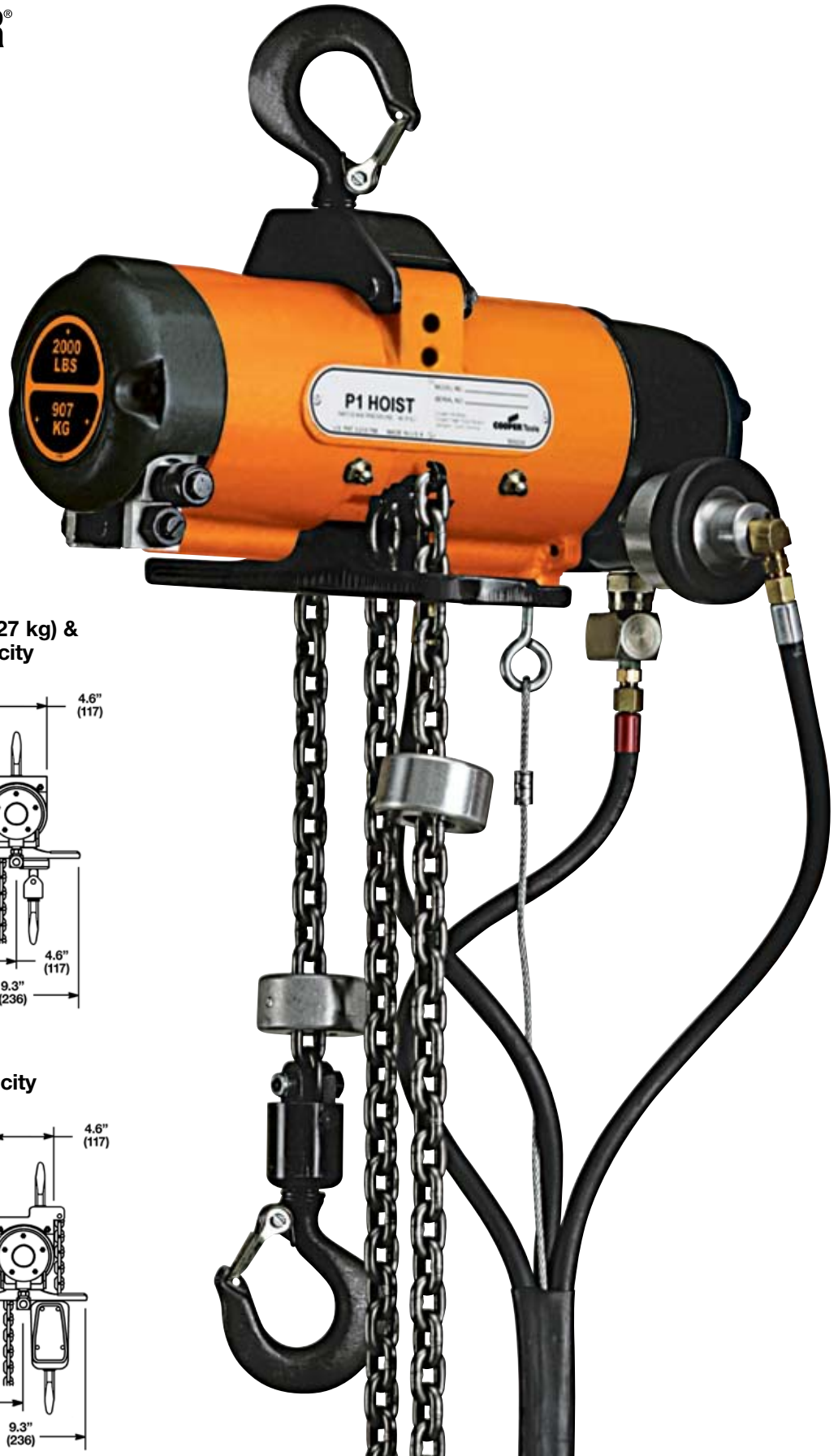

**Single Reeved**  
300 lbs. (136 kg), 500 lbs. (227 kg) &  
1000 lbs. (454 kg) Capacity

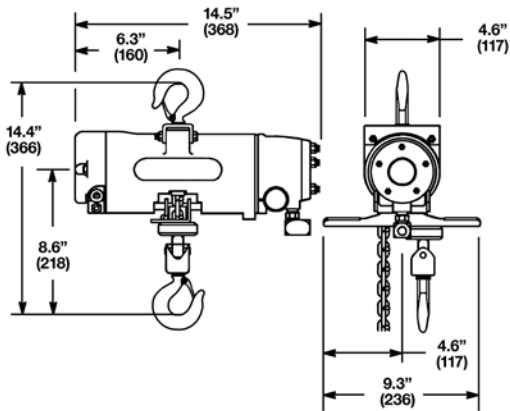

**Double Reeved**  
2000 lbs. (907 kg) Capacity

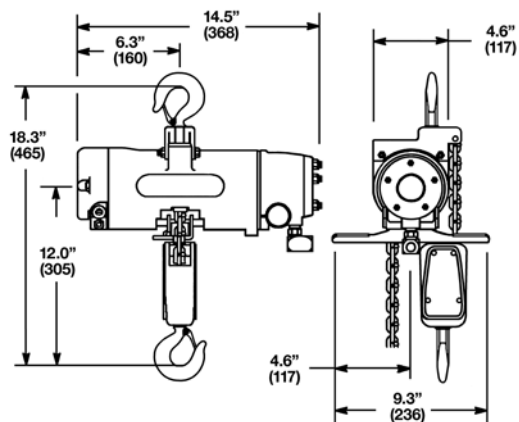



**P1 H A 03 L P E L --- A A A 03**

**SERIES**

P1

**TYPE MOUNT**

H = Hook

**FEATURES**

A = Standard Unit  
H = Hi Temp Grease  
P = Epoxy Paint  
S = Epoxy Paint/Hi Temp Grease

**CAPACITY**

03 = 300 lbs.      09 = \*1000 lbs.  
04 = \*500 lbs.    10 = 1000 lbs.  
05 = 500 lbs.     20 = 2000 lbs    \*Spark Resistant

**CHAIN TYPE**

L = Link  
R = Roller

**CONTROL TYPE**

P = Pendent (Standard-2LVR)  
R = Rope  
T = No Control Type (Rope Ready)  
W = None-Pendent Ready

**CONTROL LENGTH**

E = 5 FT            T = 20 FT  
J = 10 FT          Y = 25 FT  
O = 15 FT          Z = No Control Length

**CHAIN OPTIONS**

L = Standard Link  
N = Spark Resistant Roller  
P = Zinc Plated Link  
R = Standard Roller  
X = No Chain

**CAPACITY RATING**

03 =300 lbs. (03/04/05/09/10)  
05 =500 lbs. (04/05/09/10)  
10 =1000 lbs. (09/10)  
11 =1000 lbs. (20)  
15 =1500 lbs. (20)  
20 =2000 lbs. (20)

**VINTAGE**

A

**LOWER HOOK**

A = Standard (03/05/10)  
B = Bullard (03/05/10)  
C = S.R. Standard Roller (04/09)  
D = S.R. Bullard Roller (04/09)  
E = Standard Roller w/mod. lift (03/05/10)  
F = Bullard Roller w/10ft. lift (03/05/10)  
G = Standard Roller w/10ft. lift (03/05/10)  
H = Standard Link (20)  
I = Bullard Link (20)  
P = Bullard Roller w/mod. lift (03/05/10)  
X = No Lower Hook

**UPPER HOOK**

A = Standard (03/05/10)  
B = Bullard (03/05/10)  
C = S.R. Standard (04/09)  
D = S.R. Bullard (04/09)  
E = Standard (20)  
F = Bullard (20)  
X = No Upper Hook

**AMOUNT OF LIFT**

--- Specify Length in Feet, 3 digits  
Example: 10' lift 010

Note: Numbers in parentheses following an option, represent the hoist capacities for which that option is available.

Model Number		Chain Type	Capacity		Lifting & Lowering Speeds				Reeves	Weight	
Pendent Control	Rope Control		lbs.	kg	Lifting		Lowering			lbs.	kg
					fpm	mpm	fpm	mpm			
P1HA03LPEL010AAA03	P1HA03LREL010AAA03	Link	300	136	80	24	88	27	1	28	13
P1HA03RPER010AGA03	P1HA03RRER010AGA03	Roller	300	136	80	24	88	27	1	28	13
P1HA05LPEL010AAA05	P1HA05LREL010AAA05	Link	500	227	47	14	115	35	1	28	13
P1HA05RPER010AGA05	P1HA05RRER010AGA05	Roller	500	227	47	14	115	35	1	28	13
P1HA10LPEL010AAA10	P1HA10LREL010AAA10	Link	1000	454	19	6	49	15	1	28	13
P1HA10RPEP010AGA10	P1HA10RRER010AGA10	Roller	1000	454	19	6	49	15	1	28	13
P1HA20LPEL010EHA20	P1HA20LREL010EHA20	Link	2000	907	9.5	3	24	7	2	31	14
<b>Spark Resistant Units</b>											
P1HA04RPEN010CCA05	P1HA04RREN010CCA05	Roller	500	227	47	14	115	35	1	28	13
P1HA09RPEN010CCA10	P1HA09RREN010CCA10	Roller	1000	454	19	6	49	15	2	28	13

**General:**

Air Inlet: 3/8" NPT (use 1/2" I.D. Hose)  
Performance rated at 90 psig (6 bar/620 kPa) air pressure.  
Air Consumption 25 cfm (.71 m<sup>3</sup>/min.) at rated load.

**Standard Equipment:**

Hook mounted air hoist with 10 ft. (3.0m) lift  
Rope Control: 5 ft. (1.5m) rope length  
Pendent Control: 5 ft. (1.5m) hose length

**Extra Equipment:**

Chain container – pages 54-55  
Hoist trolleys – page 22  
Auxiliary cable (Backup suspension) – page 57  
Piped exhaust adapter (1/2" NPT) – 500344

# Hook Mounted Hoists

P2 Series

## GARDNER-DENVER®

### P2 Series

Capacity:

1100-4400 lbs. 500-2000 kg

- Axial Piston Air Motor
- Rope or Pendant Control
- Link or Roller Chain



**Single Reeved**  
1100 lbs. (500 kg), 1500 lbs. (680 kg)  
& 2200 lbs. (1000 kg) Capacity

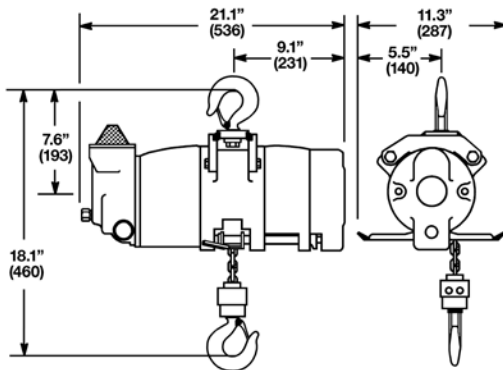

**Double Reeved**  
3000 lbs. (1360 kg) & 4400 lbs.  
(2000 kg) Capacity

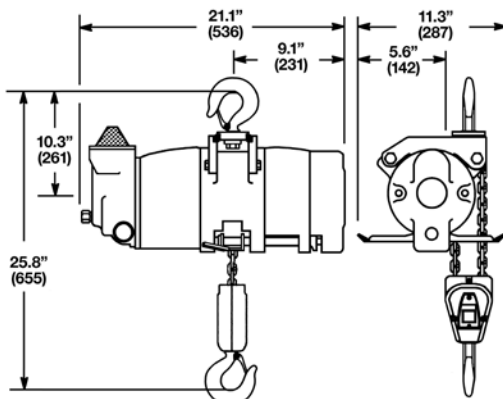

**P2 H A 11 L P E L --- A A A 11**

**SERIES**

P2

**TYPE MOUNT**

H = Hook

**FEATURES**

- A = Standard Unit
- E = Edible grease
- H = Hi Temp Grease
- P = Epoxy Paint
- R = Epoxy Paint/Edible Grease
- S = Epoxy Paint/Hi Temp Grease

**CAPACITY**

- 10 = 1000 lbs.
- 11 = 1100 lbs.
- 15 = \*1500 lbs.
- 30 = \*3000 lbs.
- 22 = 2200 lbs.
- 44 = 4400 lbs.
- \*Spark Resistant

**CHAIN TYPE**

- L = Link
- R = Roller

**CONTROL TYPE**

- P = Pendent (Standard-2LVR)
- R = Rope
- T = No Control (Rope Ready)
- W = None-Pendent Ready

**CONTROL LENGTH**

- E = 5 FT
- J = 10 FT
- O = 15 FT
- T = 20 FT
- Y = 25 FT
- Z = No Control Length

**CHAIN OPTIONS**

- L = Standard Link
- R = Standard Roller
- Q = S.R. Link
- P = Zinc Plated Link
- X = No Chain

**CAPACITY RATING**

- 03 = 300 lbs. (10/11/15)
- 05 = 500 lbs. (10/11/15)
- 10 = 1000 lbs. (10/11/15)
- 11 = 1000 lbs. (10/15/22)
- 15 = 1500 lbs. (15/22)
- 20 = 2000 lbs. (22)
- 22 = 2200 lbs. (22)
- 30 = 3000 lbs. (30/44)
- 31 = 1100 lbs. (30/44)
- 32 = 2200 lbs. (30/44)
- 40 = 4000 lbs. (44)
- 44 = 4400 lbs. (44)

**VINTAGE**

A

**LOWER HOOK**

- A = Standard (11/22)
- B = Bullard (11/22)
- C = S.R. Standard Link (10/15)
- D = S.R. Bullard (10/15)
- E = S.R. Standard Link (30)
- F = S.R. Bullard Link (30)
- G = Standard Link (44)
- H = Bullard Link (44)
- I = Standard Roller (44)
- J = Bullard Roller (44)
- K = Standard Roller (11/22)
- L = Bullard Roller (11/22)
- X = No Hook

**UPPER HOOK**

- A = Standard (11/22)
- B = Bullard (11/22)
- C = S.R. Standard (10/15)
- D = S.R. Bullard (10/15)
- E = S.R. Standard (30)
- F = S.R. Bullard (30)
- G = Standard (44)
- H = Bullard (44)
- X = No Hook

**AMOUNT OF LIFT**

--- Specify Length in Feet, 3 digits

Example: 10' lift 010

Note: Numbers in parentheses following an option, represent the hoist capacities for which that option is available.

Model Number		Chain Type	Capacity		Lifting & Lowering Speeds				Reeves	Weight	
Pendent Control	Rope Control		lbs.	kg	Lifting	Lowering		lbs.		kg	
						fpm	mpm	fpm	mpm		
P2HA11LPEL010AAA11	P2HA11LREL010AAA11	Link	1100	500	34	10	107	33	1	94	43
P2HA11RPER010AKA11	P2HA11RRER010AKA11	Roller	1100	500	34	10	107	33	1	94	43
P2HA22LPEL010AAA22	P2HA22LREL010AAA22	Link	2200	1000	17	5	56	17	1	94	43
P2HA22RPER010AKA22	P2HA22RRER010AKA22	Roller	2200	1000	17	5	56	17	1	94	43
P2HA44LPEL010GGA44	P2HA44LREL010GGA44	Link	4400	2000	9	3	28	9	2	126	57
P2HA44RPER010GIA44	P2HA44RRER010GIA44	Roller	4400	2000	9	3	28	9	2	126	57

**Spark Resistant Units**

P2HA10LPEQ010CCA10	P2HA10LREQ010CCA10	Link	1000	454	38	12	107	33	1	94	43
P2HA15LPEQ010CCA15	P2HA15LREQ010CCA15	Link	1500	680	23	7	58	18	1	94	43
P2HA30LPEQ010EEA30	P2HA30LREQ010EEA30	Link	3000	1360	11	3	26	8	2	126	57

**General:**

Air Inlet: 3/8" NPT (use 1/2" I.D. Hose)  
 Performance rated at 90 psig (6 bar/620 kPa) air pressure.  
 Air Consumption 44 cfm (1.3 m<sup>3</sup>/min.) at rated load.

**Standard Equipment:**

Hook mounted air hoist with 10 ft. (3.0m) lift  
 Rope Control: 5 ft. (1.5m) rope length  
 Pendent Control: 5 ft. (1.5m) hose length

**Extra Equipment:**

Chain container – pages 54-55  
 Hoist trolleys – page 22  
 Auxiliary cable (Backup suspension) – page 57  
 Piped exhaust adapter (3/4" NPT) – 535779

# Hook Mounted Hoists

P3 Series

## GARDNER-DENVER®

### P3 Series

Capacity:

2200-8000 lbs. 1000-3629 kg

- Axial Piston Air Motor
- Pendant Control
- Link Chain



Single Reeved  
2200 lbs. (1000 kg) &  
4300 lbs. (1950 kg) Capacity

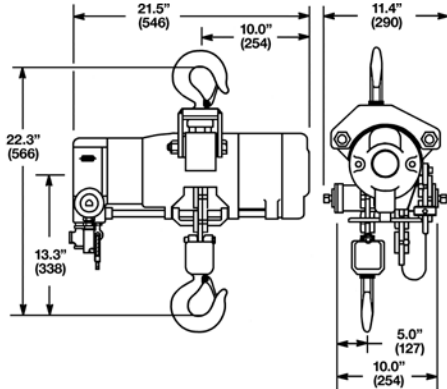

Double Reeved  
8000 lbs. (3629 kg) Capacity

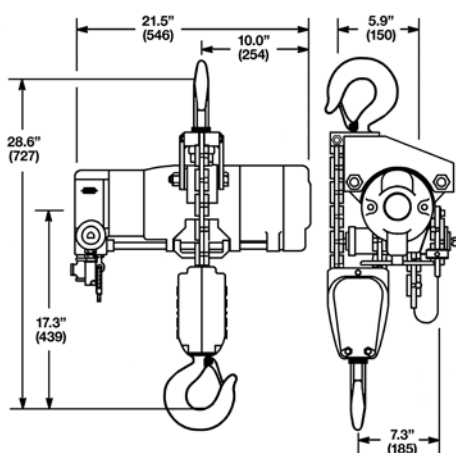



**P3 H A 22 L P E P --- A A A 22**

<p><b>SERIES</b> P3</p> <p><b>TYPE MOUNT</b> H = Hook</p> <p><b>FEATURES</b> A = Standard Unit H = Hi Temp Grease P = Epoxy Paint S = Epoxy Paint/Hi Temp Grease</p> <p><b>CAPACITY</b> 22 = 2200 lbs. 43 = 4300 lbs. 80 = 8000 lbs.</p> <p><b>CHAIN TYPE</b> L = Link</p> <p><b>CONTROL TYPE</b> L = Pendent (Hoist w/Hoist tractor-4LVR) P = Pendent Standard (STD-2LVR) X = None-Pendent ready</p> <p><b>CONTROL LENGTH</b> E = 5 FT      T = 20 FT J = 10 FT     Y = 25 FT O = 15 FT     Z = No Control Length</p> <p><b>CHAIN OPTIONS</b> P = Zinc Plated Link X = No Chain</p>	<p><b>CAPACITY RATING</b> 11 = 1100 lbs. (22) 20 = 2000 lbs. (22/43) 22 = 2200 lbs. (22/43) 40 = 4000 lbs. (43) 43 = 4300 lbs. (43) 50 = 5000 lbs. (80) 60 = 6000 lbs. (80) 80 = 8000 lbs. (80)</p> <p><b>VINTAGE</b> A</p> <p><b>LOWER HOOK</b> A = Standard (22/43) B = Bullard (22/43) C = Standard (80) D = Bullard (80) X = No Hook</p> <p><b>UPPER HOOK</b> A = Standard (22/43) B = Bullard (22/43) C = Standard (80) D = Bullard (80) X = No Hook</p> <p><b>AMOUNT OF LIFT</b> --- Specify Length in Feet, 3 digits Example: 10' lift <u>010</u></p>
--------------------------------------------------------------------------------------------------------------------------------------------------------------------------------------------------------------------------------------------------------------------------------------------------------------------------------------------------------------------------------------------------------------------------------------------------------------------------------------------------------------------------------------------------------------------------------------------------------------------------------------------------------------	--------------------------------------------------------------------------------------------------------------------------------------------------------------------------------------------------------------------------------------------------------------------------------------------------------------------------------------------------------------------------------------------------------------------------------------------------------------------------------------------------------------------------------------------------------------------------------------------------------------------------------------------------

Note: Numbers in parentheses following an option, represent the hoist capacities for which that option is available.

Model Number	Chain Type	Capacity		Lifting & Lowering Speeds				Reeves	Weight	
				Max. Lift		Max. Lower				
		lbs.	kg	fpm	mpm	fpm	mpm		lbs.	kg
P3HA22LPEP010AAA22	Link	2200	1000	30	9	80	24	1	135	61
P3HA43LPEP010AAA43	Link	4300	1950	15	5	40	12	1	135	61
P3HA80LPEP010CCA80	Link	8000	3629	7	2	20	6	2	180	82

**General:**  
Air Inlet: 1/2" NPT (use 3/4" I.D. Hose)  
Performance rated at 90 psig (6 bar/620 kPa) air pressure.  
Air Consumption 83 cfm (2.35 m<sup>3</sup>/min.) at rated load.

**Standard Equipment:**  
Hook mounted air hoist with 10 ft. (3.0) lift  
Pendent Control: 5 ft. (1.5m) hose length

**Extra Equipment:**  
Chain container – page 54-55  
Hoist trolleys – page 22  
Auxiliary cable (Backup suspension) – page 57  
Tractor connection kit – 516710

# Trolleys for Hook Mounted Hoists

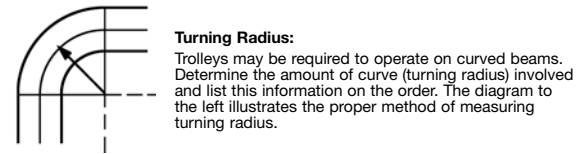
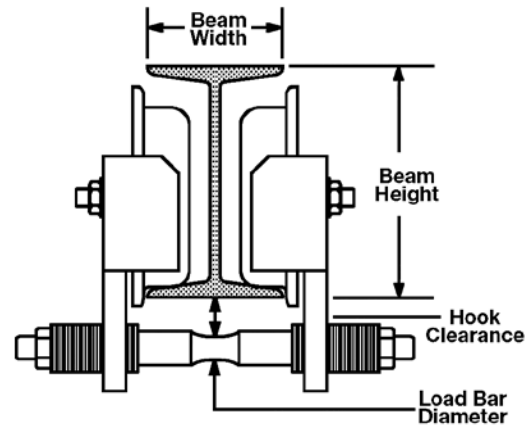

Hoist Capacity		Beam Width				Minimum Radius Turning		Part Number			Hook Clearance**		Load Bar Diameter		
		Min.		Max.				Taper Wheel	Flat Wheel	Drawbar*	in.	mm	in.	mm	
lbs.	kg	in.	mm	in.	mm	in.	mm				in.	mm	in.	mm	
<b>Hoist Series 7</b>															
275	125	2.33	59	4.66	118	18	457	532992				1.50	38	0.75	19
<b>Hoist Series K5</b>															
550	250	2.66	68	4.66	118	18	457	534925	534926	A60165	1.88	48	0.88	22	
1100	500	2.66	68	4.66	118	18	457	527431	528235	A60165	1.88	48	0.88	22	
2200	1000	3.00	76	5.25	133	21	533	527432	528236	A60164	2.25	57	1.12	28	
<b>Hoist Series K1</b>															
2200*	1000	3.00	76	5.25	133	21	533	527432	528236	A60164	2.25	57	1.12	28	
3300	1498	3.31	84	6.00	152	42	1067	534451	534709	A60164	2.25	57	1.25	32	
4400	2000	3.31	84	6.00	152	42	1067	532274	534710	A60164	2.25	57	1.25	32	
6600	3000	4.00	102	6.25	159	72	1829	531040	531040	516710	3.00	76	1.75	44	
8800	4000	4.00	102	6.25	159	72	1829	531041	531041	516710	3.00	76	1.75	44	
<b>Hoist Series P1</b>															
300	136	2.66	68	4.66	118	18	457	539383	539384	A60165	1.88	48	0.88	22	
500	227	2.66	68	4.66	118	18	457	534923	534924	A60165	1.88	48	0.88	22	
1000	454	2.66	68	4.66	118	18	457	527491	528161	A60165	1.88	48	0.88	22	
2000	908	3.00	76	5.25	133	21	533	527492	528166	A60164	2.25	57	1.12	28	
<b>Hoist Series P2</b>															
1100	500	2.66	68	4.66	118	18	457	527431	528235	A60165	1.88	48	0.88	22	
2200	1000	3.00	76	5.25	133	21	533	527432	528236	A60164	2.25	57	1.12	28	
4400	2000	3.31	84	6.00	152	42	1067	532274	534710	A60164	2.25	57	1.12	32	
<b>Hoist Series P3</b>															
2200	1000	3.00	76	5.25	133	21	533	527432	528236	A60164	2.25	57	1.12	28	
4300	1950	3.31	84	6.00	152	42	1067	528234	528237	A60164	2.25	57	1.25	32	
8000	3629	4.00	102	6.25	159	72	1829	533578	533578	516710	3.00	76	1.75	44	
<b>Spark Resistant Trolleys</b>															
<b>Hoist Series P1</b>															
500	227	2.66	68	4.66	118	18	457	539388	539389	A60165	1.88	48	0.88	22	
1000	454	3.00	76	5.25	133	21	533	539376	539377	A60164	2.25	57	1.12	28	
<b>Hoist Series P2</b>															
1500	680	3.00	76	5.25	133	21	533	528186	528179	A60164	2.25	57	1.12	28	
3000	1361	3.31	84	6.00	152	42	1067	528187	528188	A60164	2.25	57	1.12	32	

\*NOTE: Drawbar for Hoistractor  
\*\*NOTE: Dimensions are for smallest size track

# Lug Mounted Hoists

Introduction

The compact, low headroom design of lug mounted hoists make them ideal for applications where space is at a premium. This semi-permanent mount provides the greatest benefits in tight working situations where the non-rotating, non-swinging lug allows precise placement of the load. Lug mounted hoists are available with link chain only, to allow side movement of the load, and can be mounted on the appropriate Gardner-Denver trolley for horizontal movement of the load.



# Lug Mounted Hoists

K5 Series

## GARDNER-DENVER®

### K5 Series

Capacity:  
550-2200 lbs. 250-1000 kg

- Rotary Vane Air Motor
- Rope or Pendant Control
- Link Chain



Single Reeved  
550 lbs. (250 kg) & 1100 lbs.  
(500 kg) Capacity

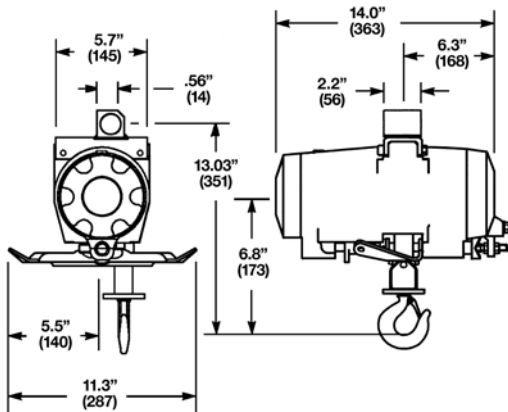

Double Reeved  
2200 lbs. (1000 kg) Capacity

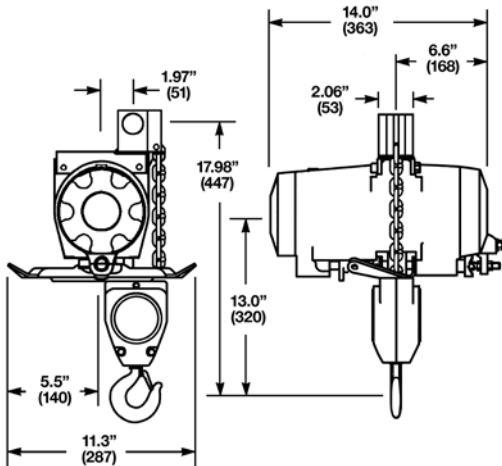



**K5 L A 05 L P E L --- A A A 05**

**SERIES**

**K5**

**TYPE MOUNT**

L = Lug

**FEATURES**

A = Standard Unit  
 H = Hi Temp Grease  
 P = Epoxy Paint  
 S = Epoxy Paint/Hi Temp Grease

**CAPACITY**

05 = 550 lbs.  
 11 = 1100 lbs.  
 22 = 2200 lbs.

**CHAIN TYPE**

L = Link

**CONTROL TYPE**

P = Pendant (Standard-2LVR)  
 R = Rope  
 W = None-Pendant Ready  
 X = None

**CONTROL LENGTH**

E = 5 FT      T = 20 FT  
 J = 10 FT     Y = 25 FT  
 O = 15 FT     Z = None

**CHAIN OPTIONS**

L = Link  
 X = No Chain

**CAPACITY RATING**

05 = 550 lbs. (05)  
 06 = 550 lbs. (22)  
 11 = 1100 lbs. (11)  
 12 = 1100 lbs. (22)  
 22 = 2200 lbs. (22)

**VINTAGE**

A

**LOWER HOOK**

A = Standard Link (05/11)  
 B = Bullard Link (05/11)  
 E = Standard Link (22)  
 F = Bullard Link (22)  
 X = No Hook

**UPPER LUG**

A = Standard (05/11)  
 B = Standard (22)  
 X = No Hook

**AMOUNT OF LIFT**

--- Specify Length in Feet, 3 digits  
 Example: 10' lift 010

Note: Numbers in parentheses following an option, represent the hoist capacities for which that option is available.

Model Number		Chain Type	Capacity		Lifting & Lowering Speeds				Reeves	Weight	
Pendant Control	Rope Control		lbs.	kg	Maximum Lift		Maximum Lower			lbs.	kg
					fpm	mpm	fpm	mpm			
K5LA05LPEL010AAA05	K5LA05LREL010AAA05	Link	550	250	40-67	12-20	110-147	33-44	1	42	19
K5LA11LPEL010AAA11	K5LA11LREL010AAA11	Link	1100	500	20-50	6-15	80-120	24-36	1	42	19
K5LA22LPEL010BEA22	K5LA22LREL010BEA22	Link	2200	1000	10-25	3-7	40-60	12-18	2	54	25

**General:**

Air Inlet: 1/2" NPT (use 3/4" I.D. Hose)  
 Performance rated at 90 psig (6.2 bar/620 kPa) air pressure.  
 Air Consumption 75 cfm (2.12m<sup>3</sup>/min.) at rated load.

**Standard Equipment:**

Lug mounted air hoist with 10 ft. (3.0m) lift  
 Rope Control: 5 ft. (1.5m) rope length  
 Pendant Control: 5 ft. (1.5m) hose length

**Extra Equipment:**

Chain container – page 54-55  
 Hoist trolleys – page 22  
 Auxiliary cable (Backup suspension) – page 57  
 Air strainer intake fitting – A10161  
 Piped exhaust adapter (3/4"NPT) – 536567

# Lug Mounted Hoists

P1 Series

## GARDNER-DENVER®

### P1 Series

Capacity:

300-2000 lbs. 136-907 kg

- Axial Piston Air Motor
- Rope or Pendant Control
- Link Chain

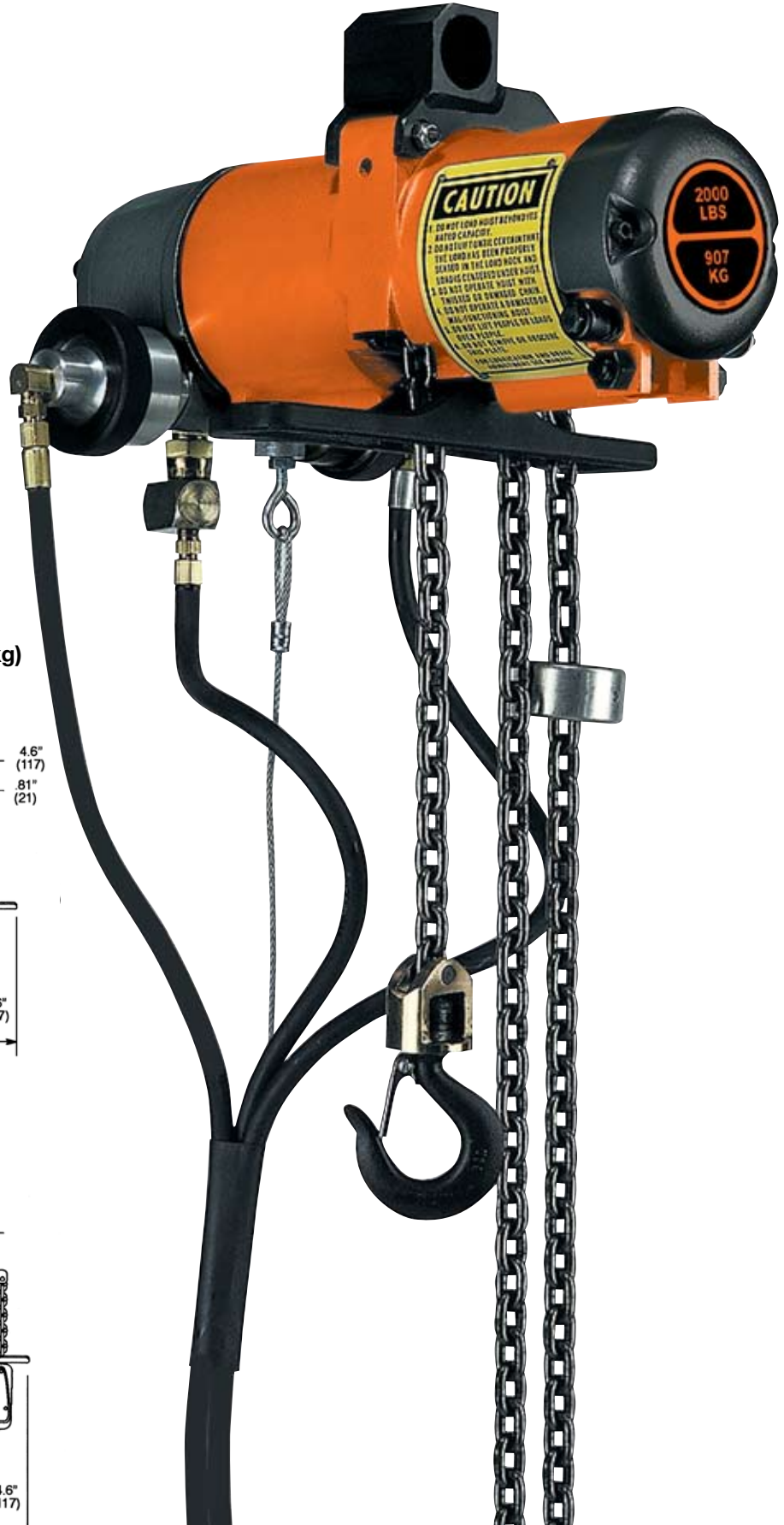

**Single Reeved**  
300 lbs. (136 kg), 500 lbs. (227 kg)  
& 1000 lbs. (454 kg) Capacity

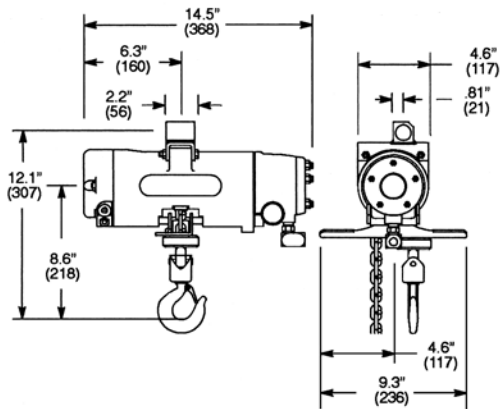

**Double Reeved**  
2000 lbs. (907 kg) Capacity

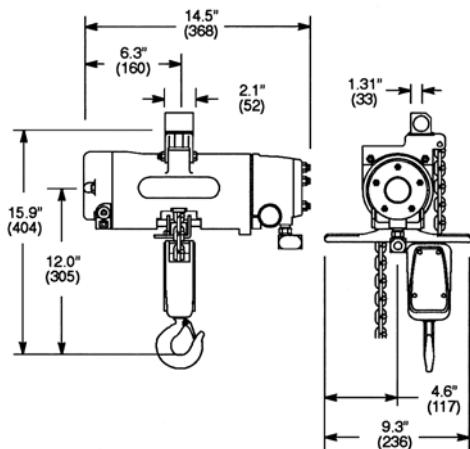

**P1 L A 03 L P E L --- A A A 03**

**SERIES**  
P1

**TYPE MOUNT**  
L = Lug

**FEATURES**  
A = Standard Unit  
H = Hi Temp Grease  
P = Epoxy Paint  
S = Epoxy Paint/Hi Temp Grease

**CAPACITY**  
03 = 300 lbs.      10 = 1000 lbs.  
05 = 500 lbs.      20 = 2000 lbs

**CHAIN TYPE**  
L = Link

**CONTROL TYPE**  
P = Pendent (Standard-2LVR)  
R = Rope  
T = No Control Type (Rope Ready)  
W = None-Pendent Ready

**CONTROL LENGTH**  
E = 5 FT      T = 20 FT  
J = 10 FT      Y = 25 FT  
O = 15 FT      Z = No Control Length

**CHAIN OPTIONS**  
L = Standard Link  
P = Zinc Plated Link  
X = No Chain

**CAPACITY RATING**  
03 =300 lbs. (03/04/05/09/10)  
05 =500 lbs. (04/05/09/10)  
10 =1000 lbs. (09/10)  
11 =1000 lbs. (20)  
15 =1500 lbs. (20)  
20 =2000 lbs. (20)

**VINTAGE**  
A

**LOWER HOOK**  
A = Standard (03/05/10)  
B = Bullard (03/05/10)  
H = Standard Link (20)  
I = Bullard Link (20)  
X = No Lower Hook

**UPPER LUG**  
A = Standard (03/05/10)  
B = Standard (20)  
X = No Upper Hook

**AMOUNT OF LIFT**  
--- Specify Length in Feet, 3 digits  
Example: 10' lift 010

Note: Numbers in parentheses following an option, represent the hoist capacities for which that option is available.

Model Number		Chain Type	Capacity		Lifting & Lowering Speeds				Reeves	Weight	
Pendent Control	Rope Control		lbs.	kg	Maximum Lift		Maximum Lower			lbs.	kg
					fpm	mpm	fpm	mpm			
P1LA03LPEL010AAA03	P1LA03LREL010AAA03	Link	300	136	80	24	88	27	1	28	13
P1LA05LPEL010AAA05	P1LA05LREL010AAA05	Link	500	227	47	14	115	35	1	28	13
P1LA10LPEL010AAA10	P1LA10LREL010AAA10	Link	1000	454	19	6	49	15	1	28	13
P1LA20LPEL010BHA20	P1LA20LREL010BHA20	Link	2000	907	9.5	3	24	7	2	31	14

**General:**  
Air Inlet: 3/8" NPT (use 1/2" I.D. Hose)  
Performance rated at 90 psig (6 bar/620 kPa) air pressure.  
Air Consumption 25 cfm (.71 m<sup>3</sup>/min.) at rated load.

**Standard Equipment:**  
Lug mounted air hoist with 10 ft. (3.0m) lift  
Rope Control: 5 ft. (1.5m) rope length  
Pendent Control: 5 ft. (1.5m) hose length

**Extra Equipment:**  
Chain container – page 54-55  
Hoist trolleys – page 22  
Auxiliary cable (Backup suspension) – page 57  
Piped exhaust adapter (1/2"NPT) – 500344

# Trolleys for Lug Mounted Hoists

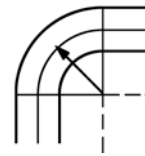
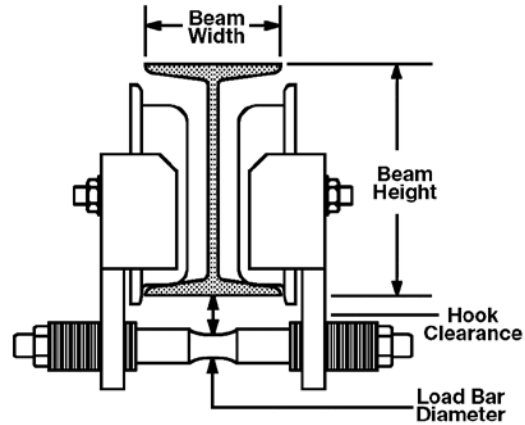

**Turning Radius:**

Trolleys may be required to operate on curved beams. Determine the amount of curve (turning radius) involved and list this information on the order. The diagram to the left illustrates the proper method of measuring turning radius.

Hoist Capacity		Beam Width				Minimum Radius Turning		Part Number			Hook Clearance**		Load Bar Diameter		
		Min.		Max.											
lbs.	kg	in.	mm	in.	mm	in.	mm	Taper Wheel	Flat Wheel	Drawbar*	in.	mm	in.	mm	
<b>Hoist Series K5</b>															
550	250	2.66	68	4.66	118	18	457	534925	534926	A60165	1.88	48	0.88	22	
1100	500	2.66	68	4.66	118	18	457	527431	528235	A60165	1.88	48	0.88	22	
2200	1000	3.00	76	5.25	133	21	533	527432	528236	A60164	2.25	57	1.12	28	
<b>Hoist Series P1</b>															
300	136	2.66	68	4.66	118	18	457	539383	539384	A60165	1.88	48	0.88	22	
500	227	2.66	68	4.66	118	18	457	534923	534924	A60165	1.88	48	0.88	22	
1000	454	2.66	68	4.66	118	18	457	527491	528161	A60165	1.88	48	0.88	22	
2000	908	3.00	76	5.25	133	21	533	527492	528166	A60164	2.25	57	1.12	28	

\*NOTE: Drawbar for Hoistractor

\*\*NOTE: Dimensions are for smallest size track



# Trolleys for Hook & Lug Mounted Hoists

Introduction

**COOPER** Tools



Trolley mounted air hoists offer a low hook-to-beam dimension for low headroom or permanent installations. The heavy-duty trolleys will adapt to almost every size "I" beam. Trolleys have ball bearing construction for easy movement and long life. Trolley mounted hoists feature link chain only, to allow side movement of load, and all are adaptable for use with the Gardner-Denver Hoistractor.

# Trolley Mounted Hoists

K5 Series

## GARDNER-DENVER®

### K5 Series

**Capacity:**

550-2200 lbs. 250-1000 kg

**Beam flange width:**

3.0-6.0 in 76-162 mm

**Minimum turning radius:**

34 in 864 mm

- Rotary Vane Air Motor
- Rope or Pendant Control
- Link Chain



**Single Reeved  
5500 lbs. (250 kg) & 1100 lbs.  
(500 kg) Capacity**

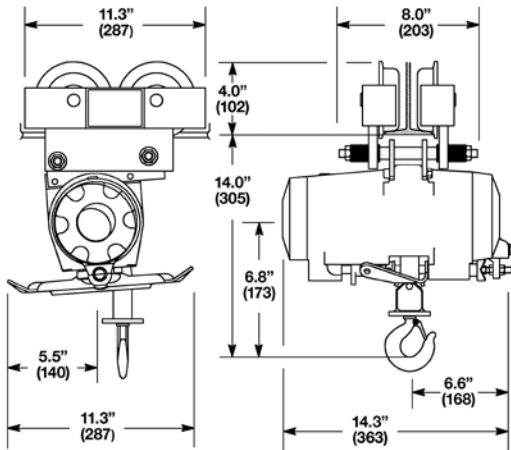

**Double Reeved  
2200 lbs. (1000 kg) Capacity**

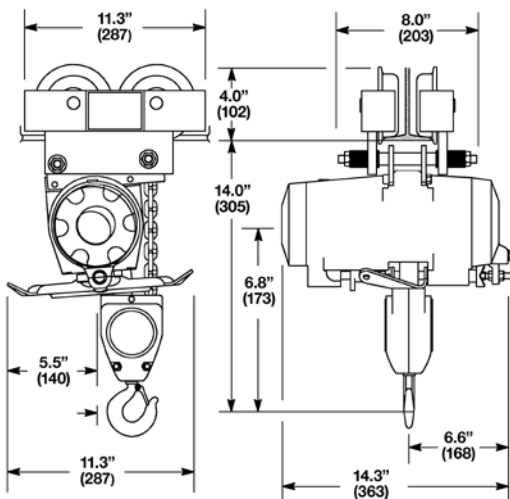

**K5 T A 05 L P E L --- A A A 05**

**SERIES**  
K5

**TYPE MOUNT**  
T = Trolley

**FEATURES**  
A = Standard Unit  
H = Hi Temp Grease  
P = Epoxy Paint  
S = Epoxy Paint/Hi Temp Grease

**CAPACITY**  
05 = 550 lbs.  
11 = 1100 lbs.  
22 = 2200 lbs.

**CHAIN TYPE**  
L = Link

**CONTROL TYPE**  
P = Pendent (Standard-2LVR)  
R = Rope  
W = None-Pendent Ready  
X = None

**CONTROL LENGTH**  
E = 5 FT      T = 20 FT  
J = 10 FT     Y = 25 FT  
O = 15 FT     Z = No Control Length

**CHAIN TYPE**  
L = Link  
X = No Chain

**CAPACITY RATING**  
05 = 550 lbs. (05/11)  
06 = 550 lbs. (22)  
11 = 1100 lbs. (11)  
12 = 1100 lbs. (22)  
22 = 2200 lbs. (22)

**VINTAGE**  
A

**LOWER HOOK**

A = Standard Link (05/11)  
B = Bullard Link (05/11)  
C = Standard Link (22)  
D = Bullard Link (22)  
X = No Hook

**TROLLEY**

A = 3-5" Tapered for (05/11/22)  
B = 5-6" Tapered for (05/11/22)  
C = 3-5" Tapered w/Hoistractor bracket (05/11/22)  
D = 5-6" Flat for (05/11/22)  
E = 3-5" Flat for (05/11/22)  
F = 3-5" Flat w/Hoistractor bracket (05/11/22)  
G = 2" Nr w Flat for (05/11/22)  
H = 2" Nr w Flat w/Hoistractor bracket (05/11/22)

**AMOUNT OF LIFT**

--- Specify Length in Feet, 3 digits  
Example: 10' lift\_010

Note: Numbers in parentheses following an option, represent the hoist capacities for which that option is available.

Model Number		Chain Type	Capacity		Lifting & Lowering Speeds				Reeves	Weight	
Pendent Control	Rope Control		lbs.	kg	Maximum Lift		Maximum Lower			lbs.	kg
					fpm	mpm	fpm	mpm			
K5TA05LPEL010AAA05	K5TA05LREL010AAA05	Link	550	250	40-67	12-20	110-147	33-44	1	82	37
K5TA11LPEL010AAA11	K5TA11LREL010AAA11	Link	1100	500	20-50	6-15	80-120	24-36	1	82	37
K5TA22LPEL010ACA22	K5TA22LREL010ACA22	Link	2200	1000	10-25	3-7	40-60	12-18	2	93	42

**General:**  
Air Inlet: 1/2" NPT (use 3/4" I.D. Hose)  
Performance rated at 90 psig (6 bar/620 kPa) air pressure.  
Air Consumption 75 cfm (2.12 m<sup>3</sup>/min.) at rated load.

**Standard Equipment:**  
Trolley mounted air hoist with 10 ft. (3.0m) lift  
Tapered Wheels  
Rope Control: 5 ft. (1.5m) rope length  
Pendent Control: 5 ft. (1.5m) hose length

**Extra Equipment:**  
Chain container – page 54-55  
Air strainer intake fitting – A10161  
Piped exhaust adapter (3/4" NPT) – 536567  
Tractor connection kit – 530388 (Used to modify existing Hoist)



# Trolley Mounted Hoists

K1 Series

## GARDNER-DENVER®

### K1 Series

**Capacity:**

2200-8800 lbs. 1000-4000 kg

**Beam flange width:**

2200, 3300, 4400 lbs. cap.

3.00-6.25 in 76-159 mm

6600, 8800 lbs. capacity

4.00-6.25 in 102-159 mm

**Minimum turning radius:**

2200, 3300, 4400 lbs. cap.

60 in 1524 mm

6600, 8800 lbs. cap.

72 in 1829 mm

- Rotary Vane Air Motor
- Rope or Pendant Control
- Link Chain



**Single Reeved**

2200 lbs. (1000 kg), 3300 lbs. (1500 kg)  
& 4400 lbs. (2000 kg) Capacity

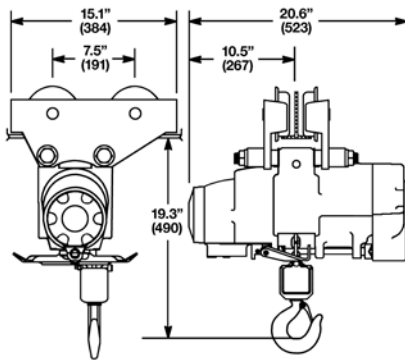

**Double Reeved**  
6600 lbs. (3000 kg) &  
8800 lbs. (4000 kg) Capacity

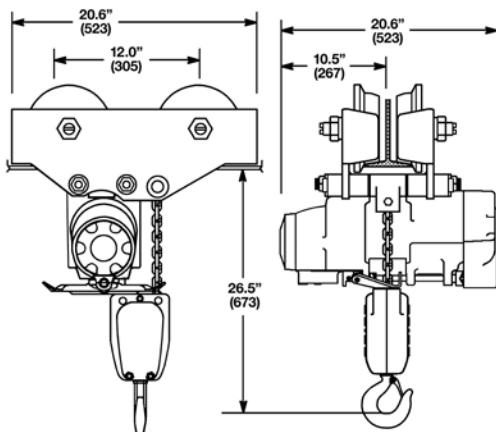



**K1 T A 22 L P E P --- A A A 22**

**SERIES**  
K1

**TYPE MOUNT**  
T = Trolley

**FEATURES**  
A = Standard Unit  
H = Hi Temp Grease  
P = Epoxy Paint  
S = Epoxy Paint/Hi Temp Grease

**CAPACITY**  
22 = 2200 lbs.      66 = 6600 lbs.  
33 = 3300 lbs.      88 = 8800 lbs.  
44 = 4400 lbs.

**CHAIN TYPE**  
L = Link

**CONTROL TYPE**  
P = Pendent (Standard-2LVR)  
R = Rope  
W = None-Pendent Ready  
X = None

**CONTROL LENGTH**  
E = 5 FT      T = 20 FT  
J = 10 FT      Y = 25 FT  
O = 15 FT      Z = No Control Length

**CHAIN OPTIONS**  
P = Zinc Plated Link  
X = No Chain

**CAPACITY RATING**  
11 = 1100 lbs. (22/33/44)  
22 = 2200 lbs. (22/33/44)  
33 = 3300 lbs. (33/44)  
34 = 3300 lbs. (66)  
44 = 4400 lbs. (44)  
45 = 4400 lbs. (66/88)  
66 = 6600 lbs. (66)  
88 = 8800 lbs. (88)

**VINTAGE**  
A

**LOWER HOOK**

A = Standard Link (22/33/44)  
B = Bullard Link (22/33/44)  
C = Standard Link (66/88)  
D = Bullard Link (66/88)  
X = No Hook

**TROLLEY**

A = 3-6.25" Tapered (22/33/44)  
B = 4-6.25" Tapered (66/88)  
C = 3.25" NrW Flat (66/88)  
D = 3-6.25" Flat (22/33/44)  
E = 4-6.25" Flat (66/88)  
F = 2" NrW Flat (22/33/44)

**AMOUNT OF LIFT**

--- Specify Length in Feet, 3 digits  
Example: 10' lift 010

Note: Numbers in parentheses following an option, represent the hoist capacities for which that option is available.

Model Number		Chain Type	Capacity		Lifting & Lowering Speeds				Reeves	Weight	
Pendent Control	Rope Control		lbs.	kg	Maximum Lift		Maximum Lower			lbs.	kg
					fpm	mpm	fpm	mpm			
K1TA22LPEP010AAA22	K1TA22LREP010AAA22	Link	2200	1000	33	10	52	16	1	270	123
K1TA33LPEP010AAA33	K1TA33LREP010AAA33	Link	3300	1500	21	6	34	10	1	270	123
K1TA44LPEP010AAA44	K1TA44LREP010AAA44	Link	4400	2000	15	5	24	7	1	270	123
K1TA66LPEP010BCA66	K1TA66LREP010BCA66	Link	6600	3000	10	3	17	5	2	278	140
K1TA88LPEP010BCA88	K1TA88LREP010BCA88	Link	8800	4000	7	2	12	4	2	278	140

**General:**  
Air Inlet: 1/2" NPT (use 3/4" I.D. Hose)  
Performance rated at 90 psig (6 bar/620 kPa) air pressure.  
Air Consumption 75 cfm (2.12 m<sup>3</sup>/min.) at rated load.

**Standard Equipment:**  
Trolley mounted air hoist with 10 ft. (3.0m) lift  
Tapered Wheels  
Rope Control: 5 ft. (1.5m) rope length  
Pendent Control: 5 ft. (1.5m) hose length

**Extra Equipment:**  
Chain container – page 54-55  
Piped exhaust adapter (3/4" NPT) – 536567  
Tractor connection kit – 516710 (Used to modify existing Hoist)

# Trolley Mounted Hoists

P1 Series

## GARDNER-DENVER®

### P1 Series

Capacity:  
300-1000 lbs. 136-454 kg

Beam flange width:  
2.63-5.00 in 67-127 mm

Minimum turning radius:  
26 in 660 mm

- Axial Piston Air Motor
- Rope or Pendant Control
- Link Chain



Single Reeved  
300 lbs. (136 kg), 500 lbs. (227 kg)  
& 1000 lbs. (454 kg) Capacity

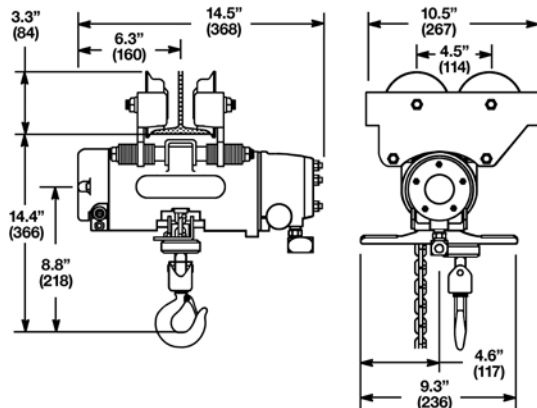

**P1 T A 05 L P E L --- A A A 05**

**SERIES**

P1

**TYPE MOUNT**

T = Trolley

**FEATURES**

A = Standard Unit  
H = Hi Temp Grease  
P = Epoxy Paint  
S = Epoxy Paint/Hi Temp Grease

**CAPACITY**

03 = 300 lbs.  
05 = 500 lbs.  
10 = 1000 lbs.

**CHAIN TYPE**

L = Link

**CONTROL TYPE**

P = Pendent (Standard-2LVR)  
R = Rope  
W = None-Pendent Ready  
T = No Control Type (Rope Ready)

**CONTROL LENGTH**

E = 5 FT      T = 20 FT  
J = 10 FT     Y = 25 FT  
O = 15 FT     Z = No Control Length

**CHAIN OPTIONS**

L = Standard Link  
P = Zinc Plated Link  
X = No Chain

**CAPACITY RATING**

03 = 300 lbs. (03/05/10)  
05 = 500 lbs. (05/10)  
10 = 1000 lbs. (10)

**VINTAGE**

A

**LOWER HOOK**

A = Standard (03/05/10)  
B = Bullard (03/05/10)  
X = No Hook

**TROLLEY**

A = 2.63-5" Tapered (03/05/10) (standard)  
B = 5-7" Tapered (03/05/10)  
C = 2.63-5" Tapered w/Hoistractor bracket (03/05/10)  
D = 5-7" Flat (03/05/10)  
E = 2.63-5" Flat (03/05/10)  
F = 2.63-5" Flat w/Hoistractor bracket (03/05/10)  
G = 2" Nr w Flat (03/05/10)  
H = 2" Nr w Flat w/Hoistractor bracket (03/05/10)

**AMOUNT OF LIFT**

--- Specify Length in Feet, 3 digits  
Example: 10' lift 010

Note: Numbers in parentheses following an option, represent the hoist capacities for which that option is available.

Model Number		Chain Type	Capacity		Lifting & Lowering Speeds				Reeves	Weight	
Pendent Control	Rope Control		lbs.	kg	Lifting		Lowering			lbs.	kg
						fpm	mpm	fpm	mpm		
P1TA03LPEL010AAA03	P1TA03LREL010AAA03	Link	300	136	80	24	88	27	1	50	23
P1TA05LPEL010AAA05	P1TA05LREL010AAA05	Link	500	227	47	14	115	35	1	50	23
P1TA10LPEL010AAA10	P1TA10LREL010AAA10	Link	1000	454	19	6	49	15	1	50	23

**General:**

Air Inlet: 3/8" NPT (use 1/2" I.D. Hose)  
Performance rated at 90 psig (6 bar/620 kPa) air pressure.  
Air Consumption 25 cfm (.71 m<sup>3</sup>/min.) at rated load.

**Extra Equipment:**

Chain container – page 54-55  
Piped exhaust adapter (1/2" NPT) – 500344  
Tractor connection kit – 502953 (Used to modify existing Hoist)

**Standard Equipment:**

Trolley mounted air hoist with 10 ft. (3.0m) lift  
Tapered Wheels  
Rope Control: 5 ft. (1.5m) rope length  
Pendent Control: 5 ft. (1.5m) hose length

# Trolley Mounted Hoists

P2 Series

## GARDNER-DENVER®

### P2 Series

**Capacity:**

1100-4400 lbs. 500-2000 kg

**Beam flange width:**

3.00-5.00 in 76-127 mm

**Minimum turning radius:**

1000 lbs., 1100 lbs., 1500 lbs.,  
2200 lbs. capacity  
36 in 914 mm

3000 lbs., 4400 lbs. capacity  
60 in 1524 mm

- Axial Piston Air Motor
- Rope or Pendant Control
- Link Chain



**Single Reeved**

1100 lbs. (500 kg), 1500 lbs. (680 kg)  
& 2200 lbs. (1000 kg) Capacity

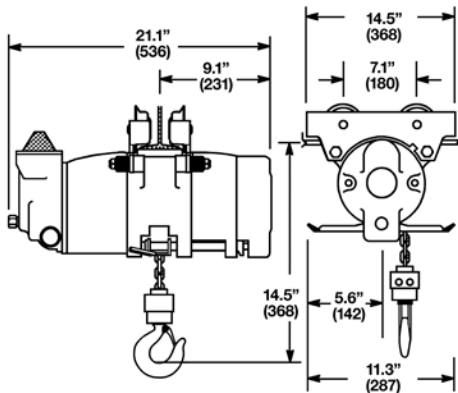

**Double Reeved**  
3000 lbs. (1360 kg) &  
4400 lbs. (2000 kg) Capacity

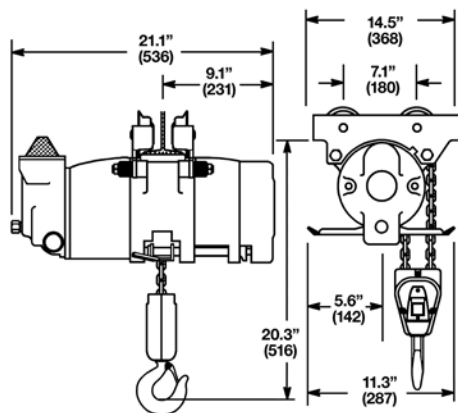



**P2 T A 11 L P E L --- A A A 11**

**SERIES**

P2

**TYPE MOUNT**

T = Trolley

**FEATURES**

- A = Standard Unit
- E = Edible Grease
- H = Hi Temp Grease
- P = Epoxy Paint
- R = Epoxy Paint/Edible Grease
- S = Epoxy Paint/Hi Temp Grease

**CAPACITY**

- 10 = 1000 lbs.
- 11 = 1100 lbs.
- 15 = \*1500 lbs.
- 22 = 2200 lbs.
- 30 = \*3000 lbs.
- 44 = 4400 lbs.

\*Spark Resistant

**CHAIN TYPE**

L = Link

**CONTROL TYPE**

- P = Pendent (Standard-2LVR)
- R = Rope
- W = None-Pendent Ready
- T = No Control (Rope Ready)

**CONTROL LENGTH**

- E = 5 FT
- J = 10 FT
- O = 15 FT
- T = 20 FT
- Y = 25 FT
- Z = No Control Length

**CHAIN OPTIONS**

- L = Standard Link
- P = Zinc Plated Link
- Q = S.R. Link
- X = No Chain

Note: Numbers in parentheses following an option, represent the hoist capacities for which that option is available.

**CAPACITY RATING**

- 03= 300 lbs. (10/11/15)
- 05= 500 lbs. (10/11/15)
- 10= 1000 lbs. (10/11/15)
- 11= 1100 lbs. (11/15/22)
- 15= 1500 lbs. (15/22)
- 20= 2000 lbs. (22)
- 22= 2200 lbs. (22)
- 30= 3000 lbs. (30/44)
- 31= 1100 lbs. (30)
- 32= 2200 lbs. (30/44)
- 40= 4000 lbs. (44)
- 44= 4400 lbs. (44)

**VINTAGE**

A

**LOWER HOOK**

- A = Standard (11/22)
- B = Bullard (11/22)
- C = S.R. Std. (10/15)
- D = S.R. Bullard (10/15)
- E = S.R. Std. (30)
- F = S.R. Bullard (30)
- G = Standard (44)
- H = Bullard (44)
- X = No Hook

**TROLLEY**

- A = 3-5" Tapered (11/22)
- B = 3-5" Tapered S.R. (10/15)
- C = 3-5" Tapered S.R. (30)
- D = 3-5" Tapered (44)
- E = 3-5" Flat (11/22)
- F = 3-5" Flat S.R. (10/15)
- G = 3-5" Flat S.R. (30)
- H = 3-5" Flat (44)
- I = 2" NrW Flat (11/22)
- J = 2" NrW Flat S.R. (10/15)
- K = 2" NrW Flat S.R. (30)
- L = 2" NrW Flat (44)
- M = 5-7" Tapered (11/22)
- N = 5-7" Tapered (44)
- O = 5-7" Tapered S.R. (10/15)
- P = 5-7" Tapered S.R. (30)
- Q = 5-7" Flat (11/22)
- R = 5-7" Flat (44)
- S = 5-7" Flat S.R. (10/15)
- T = 5-7" Flat S.R. (30)

**AMOUNT OF LIFT**

--- Specify Length in Feet, 3 digits  
Example: 10' lift 010

Model Number		Chain Type	Capacity		Lifting & Lowering Speeds				Reeves	Weight	
Pendent Control	Rope Control		lbs.	kg	Maximum Lift		Maximum Lower			lbs.	kg
						fpm	mpm	fpm	mpm		
P2TA11LPEL010AAA11	P2TA11LREL010AAA11	Link	1100	500	34	10	107	33	1	113	51
P2TA22LPEL010AAA22	P2TA22LREL010AAA22	Link	2200	1000	17	5	56	17	1	113	51
P2TA44LPEL010DGA44	P2TA44LREL010DGA44	Link	4400	2000	9	3	28	9	2	145	66
<b>Spark Resistant Units</b>											
P2TA10LPEQ010BCA10	P2TA10LREQ010BCA10	Link	1000	454	38	12	107	33	1	113	51
P2TA15LPEQ010BCA15	P2TA15LREQ010BCA15	Link	1500	680	23	7	58	18	1	113	51
P2TA30LPEQ010CEA30	P2TA30LREQ010CEA30	Link	3000	1360	11	3	26	8	2	145	66

**General:**

Air Inlet: 3/8" NPT (use 1/2" I.D. Hose)  
Performance rated at 90 psig (6 bar/620 kPa) air pressure.  
Air Consumption 44 cfm (1.2 m<sup>3</sup>/min.) at rated load.

**Standard Equipment:**

Trolley mounted air hoist with 10 ft. (3.0m) lift  
Tapered Wheels  
Rope Control: 5 ft. (1.5m) rope length  
Pendent Control: 5 ft. (1.5m) hose length

**Extra Equipment:**

Modified lift length (specify when ordering)  
Chain container – page 54-55  
Piped exhaust adapter (3/4" NPT) – 535779  
Tractor connection kit: (Used to modify existing Hoist)  
(1100, 1500, 2200 cap.) – 534919  
(3000, 4400 cap.) – 534920

# Trolley Mounted Hoists

P3 Series

## GARDNER-DENVER®

### P3 Series

#### Capacity:

2200-8000 lbs. 1000-3629 kg

#### Beam flange width:

2200 lbs., 4300 lbs. capacity  
3.38-6.25 in 86-159 mm

8000 lbs. capacity  
4.00-6.25 in 102-159 mm

#### Minimum turning radius:

2200 lbs., 4300 lbs. capacity  
60 in 1524 mm

8000 lbs. capacity  
72 in 1829 mm

- Axial Piston Air Motor
- Pendant Control
- Link Chain



Single Reeved  
2200 lbs. (1000 kg) &  
4300 lbs. (1950 kg) Capacity

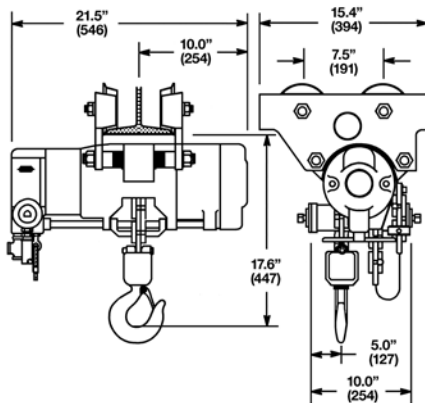

Double Reeved  
8000 lbs. (3629 kg) Capacity

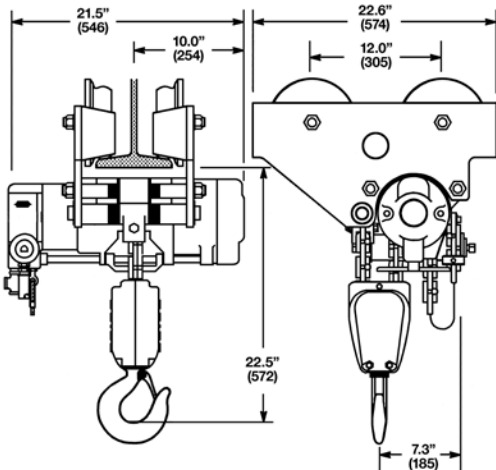

**P3 T A 22 L P E P --- A A A 22**

**SERIES**  
P3

**TYPE MOUNT**  
T = Trolley

**FEATURES**  
A = Standard Unit  
H = Hi Temp Grease  
P = Epoxy Paint  
S = Epoxy Paint/Hi Temp Grease

**CAPACITY**  
22 = 2200 lbs.  
43 = 4300 lbs.  
80 = 8000 lbs.

**CHAIN TYPE**  
L = Link

**CONTROL TYPE**  
P = Pendant Standard (2LVR)  
X = None-Pendant Ready

**CONTROL LENGTH**  
E = 5 FT      T = 20 FT  
J = 10 FT     Y = 25 FT  
O = 15 FT     Z = No Control Length

**CHAIN OPTIONS**  
P = Zinc Plated Link  
X = No Chain

**CAPACITY RATING**

11 = 1100 lbs. (22)  
20 = 2000 lbs. (22/43)  
22 = 2200 lbs. (22/43)  
40 = 4000 lbs. (43)  
43 = 4300 lbs. (43)  
50 = 5000 lbs. (80)  
60 = 6000 lbs. (80)  
80 = 8000 lbs. (80)

**VINTAGE**

A

**LOWER HOOK**

A = Standard (22/43)  
B = Bullard (22/43)  
C = Standard (80)  
D = Bullard (80)  
X = No Hook

**TROLLEY**

A = 3.38-6.25" Tapered (22/43)  
B = 4-6.25" Tapered (80)  
C = 3.25-3.33" NrW Flat (80)  
D = 3.38-6.25" Flat (22/43)  
E = 4-6.25" Flat (80)

**AMOUNT OF LIFT**

--- Specify Length in Feet, 3 digits  
Example: 10' lift 010

Note: Numbers in parentheses following an option, represent the hoist capacities for which that option is available.

Model Number	Chain Type	Capacity		Lifting & Lowering Speeds				Reeves	Weight	
				Maximum Lift		Maximum Lower				
		lbs.	kg	fpm	mpm	fpm	mpm		lbs.	kg
P3TA22LPEP010AAA22	Link	2200	1000	30	9	80	24	1	270	123
P3TA43LPEP010AAA43	Link	4300	1950	15	5	40	12	1	270	123
P3TA80LPEP010BCA80	Link	8000	3629	7	2	20	6	2	335	152

**General:**  
Air Inlet: 1/2" NPT (use 3/4" I.D. Hose)  
Performance rated at 90 psig (6 bar/620 kPa) air pressure.  
Air Consumption 83 cfm (2.35 m<sup>3</sup>/min.) at rated load.

**Standard Equipment:**  
Trolley mounted air hoist with 10 ft. (3.0m) lift  
Tapered Wheels  
Pendant Control: 5 ft. (1.5m) hose length

**Extra Equipment:**  
Chain container – page 54-55



# Hoistractor & Hoist/Hoistractor Combination Units

## Introduction

### **Hoistractor**

When used with a hoist, the powerful, lightweight Hoistractor moves heavy loads quickly and without operator fatigue. The Hoistractor may be attached to a variety of different styles of trolley mounted hoists, and speed of travel is variable from a slow creep to full speed. With a single one-hand control for Hoistractor and hoist, the operator can raise, lower or move loads with positive control. While sensitive piston-actuated air controls permit smooth acceleration and deceleration, the mechanical brake provides positive stopping to spot loads precisely.

### **Combination Units**

Gardner-Denver Hoist/Hoistractor Units combine a hoist and Hoistractor within a common frame to provide a powerful and versatile means of handling materials. These units fit a wide variety of "I" beams, cover an extensive range of lifting capacities and speeds, and eliminated extra sideplates, wheels, drawbars, etc., required by conventional arrangements.

### **Low Headroom**

Designed with hoist and Hoistractor combined as one unit, Gardner-Denver low headroom hoists are ideal where maximum use must be made of available space. They fit a variety of beam sizes and are the ultimate in compact design with minimum hook-to-beam dimensions.







### Wheel Options

Gardner-Denver Hoistactors come standard with a neoprene drive wheel, however for improved wear resistance and extended life, a molded adiprene wheel is also available. Please contact a Gardner-Denver service technician for applications involving high temperature.

### Drive Options

For added flexibility and safety, Gardner-Denver Hoistactors are available with your choice of three different drive options. As described below, each option has its advantages whether it be ease of operation or positive stopping characteristics.

#### Standard Drive

##### ■ Even number of levers

The standard Hoistactor drive utilizes a powerful compression spring to hold the drive wheel in engagement with the beam. This type of drive requires only two pendant levers to control horizontal movement in forward and reverse. When either the forward or reverse lever is depressed, the Hoistactor immediately moves in the corresponding direction until the lever is released. Upon releasing the lever, a brake engages, and the load comes to an immediate stop.

This type of drive provides the simplest method for movement and precision location of a load.

#### Free Wheel to Positive Drive

##### ■ Even number of levers

Requiring only two pendant levers to control horizontal movement, forward and reverse, this drive feature utilizes a drive wheel that is normally disengaged from the beam, allowing free movement of the load. When either the forward or reverse lever is depressed, the drive wheel is automatically moved into engagement with the beam by means of an air cylinder. Upon engagement, the load will move in the corresponding direction until the lever is released. When the lever is released, the drive wheel gradually disengages from the beam; this action will slow the horizontal movement of the load somewhat, before coasting to a stop. Because the drive wheel is normally disengaged, this type of drive allows the operator to manually position the load.

##### ■ Odd number of levers only

Requiring at least three pendant levers for operation, one to engage the wheel, and two to control forward and reverse horizontal movement, this drive feature utilizes a drive wheel that is normally disengaged from the beam, allowing free movement of the load. To advance the Hoistactor the operator must depress one lever to

move the wheel into engagement with the beam, and a second lever to impart horizontal movement. The load will continue to move along the beam as long as both levers remain depressed. If the movement lever is released while the beam engagement lever remains depressed, the Hoistactor brake will engage, and the unit will come to an immediate stop. However, if the beam engagement lever is released before the motion lever, the drive wheel will move out of engagement with the beam, and the load will coast to a stop.

This drive type allows greater control over the horizontal movement of the load because the operator manually controls the engagement of the drive wheel with the beam.



#### Positive Drive to Free Wheel

##### ■ Odd number of levers only

This type of drive is very similar to the previous except that the drive wheel is normally held in engagement with the beam by an air cylinder, and will remain so until pressure is bled from the cylinder by depressing the appropriate lever. Available only with an odd number of levers, two to control horizontal movement and one to disengage the drive wheel for manual movement, this drive provides the added safety feature of an immediate stop upon release of the levers.

To advance the Hoistactor, the operator must depress either the forward or reverse lever, the load will continue to move along the beam as long as the lever remains depressed. Upon release of the lever, the brake will engage, and the load will come to an immediate stop. If the lever to disengage the drive wheel is depressed while the load is in motion, the drive wheel will disengage from the beam, and the load will coast freely.

The benefit of this type of drive is that the Hoistactor brake will not allow movement of the load unless the one of the levers is depressed, or air pressure is bled off. However, if the operator wishes to manually move the load for precise positioning, he has but to depress the lever to disengage the drive wheel.

## GARDNER-DENVER®

### TA Series

**Traversing Speed (no load):**  
40-240 fpm 12-73 mpm

**Beam flange width:**  
2.60-6.00 in 66-152 mm

**Minimum turning radius:**  
21 in 533 mm

- Axial Piston Air Motor
- Pendant Control
- Neoprene Wheel Drive



Standard Unit*	Model Number		Traversing Speed			
	Free Wheel to Positive Drive	Positive Drive to Free Wheel	No Load		4000 lb. Load	
			fpm	mpm	fpm	mpm
<b>Universal Units</b>						
TATA04NPESXAXA	TATA04OAE GXAXA	TATA04PBEPXAXA	40	12	40	12
TATA12NPESXAXA	TATA12OAE GXAXA	TATA12PBEPXAXA	120	37	90	27
TATA24NPESXAXA	TATA24OAE GXAXA	TATA24PBEPXAXA	240	73	180	55
<b>K5 – All</b>						
TATA04NDESCAXA	TATA04OEEG CAXA	TATA04PFEP CAXA	40	12	40	12
TATA12NDESCAXA	TATA12OEEG CAXA	TATA12PFEP CAXA	120	37	90	27
TATA24NDESCAXA	TATA24OEEG CAXA	TATA24PFEP CAXA	240	73	180	55
<b>K1 – All</b>						
TATA04NDESKAXA	TATA04OEEG KAXA	TATA04PFEP KAXA	40	12	40	12
TATA12NDESKAXA	TATA12OEEG KAXA	TATA12PFEP KAXA	120	37	90	27
TATA24NDESKAXA	TATA24OEEG KAXA	TATA24PFEP KAXA	240	73	180	55
<b>P1 – All</b>						
TATA04NDESDAXA	TATA04OEEG DAXA	TATA04PFEP DAXA	40	12	40	12
TATA12NDESDAXA	TATA12OEEG DAXA	TATA12PFEP DAXA	120	37	90	27
TATA24NDESDAXA	TATA24OEEG DAXA	TATA24PFEP DAXA	240	73	180	55
<b>P2 – 1100 &amp; 2200</b>						
TATA04NDESEAXA	TATA04OEEG EAXA	TATA04PFEP EAXA	40	12	40	12
TATA12NDESEAXA	TATA12OEEG EAXA	TATA12PFEP EAXA	120	37	90	27
TATA24NDESEAXA	TATA24OEEG EAXA	TATA24PFEP EAXA	240	73	180	55
<b>P2 – 4400</b>						
TATA04NDESFAXA	TATA04OEEG FAXA	TATA04PFEP FAXA	40	12	40	12
TATA12NDESFAXA	TATA12OEEG FAXA	TATA12PFEP FAXA	120	37	90	27
TATA24NDESFAXA	TATA24OEEG FAXA	TATA24PFEP FAXA	240	73	180	55
<b>Universal Spark Resistant Units</b>						
TATA04NPESXBXA			40	12	40	12
TATA12NPESXBXA			120	37	90	27
TATA24NPESXBXA			240	73	180	55
<b>P2 – 1500 Spark Resistant</b>						
TATA04NDESEBXA			40	12	40	12
TATA12NDESEBXA			120	37	90	27
TATA24NDESEBXA			240	73	180	55
<b>P2 – 3000 Spark Resistant</b>						
TATA04NDESF BXA			40	12	40	12
TATA12NDESF BXA			120	37	90	27
TATA24NDESF BXA			240	73	180	55
<b>P3 – All</b>						
TATA04NDESHAXA	TATA04OEEG HAXA	TATA04PFEP HAXA	40	12	40	12
TATA12NDESHAXA	TATA12OEEG HAXA	TATA12PFEP HAXA	120	37	90	27
TATA24NDESHAXA	TATA24OEEG HAXA	TATA24PFEP HAXA	240	73	180	55

\*NOTE: Spring engagement

**General:**

Air Inlet: 3/8" NPT (use 1/2" I.D. Hose)  
Performance rated at 90 psig (6 bar/620 kPa) air pressure.  
Air Consumption 30 cfm (.80 m<sup>3</sup>/min.) at rated load.  
Nominal weight: 70 lbs. (32 kg)

**Standard Equipment:**

Hoistractor with Pendant Control: 5 ft. (1.5m) hose length

**Extra Equipment:**

Piped exhaust adapter (1/2" NPT) – 500344  
Flow Control Valve (3/8" NPT) – 502905

**TA T A 04 N P E S X A X A**

**SERIES**

TA

**TYPE MOUNT**

T = Trolley

**FEATURES**

A = Standard Unit    P = Epoxy Paint  
 E = Edible Grease    R = Epoxy Paint/Edible Grease  
 H = Hi Temp Grease    S = Epoxy Paint/Hi Temp Grease

**TRANSVERSING SPEED**

04 = 40 fpm  
 12 = 120 fpm  
 24 = 240 fpm

**DRIVE WHEEL TYPE**

**Neoprene Drive Wheel**

N = Spring engagement  
 M = Free wheel to positive drive\*  
 (2 or 4 lever pendent control handle)  
 O = Free wheel to positive drive\*  
 (3 or 5 lever pendent control handle)  
 P = Positive drive to free wheel\*  
 (3 or 5 lever pendent control handle)

**Adiprene Drive Wheel**

A = Spring engagement  
 B = Free wheel to positive drive\*  
 (2 or 4 lever pendent control handle)  
 C = Free wheel to positive drive\*  
 (3 or 5 lever pendent control handle)  
 D = Positive drive to free wheel\*  
 (3 or 5 lever pendent control handle)

**CONTROL TYPE**

A = Free to positive (3/LVR)\*    P = Standard (2/LVR)\*\*  
 B = Positive to free (3/LVR)\*    R = Rope Standard  
 D = Standard hoist w/Hoistractor (4 LVR)\*\*    T = None (Rope ready)  
 E = Free to positive (5/LVR)\*    W = None (Pendent Ready)  
 F = Positive to free (5/LVR)\*    \*See page 39  
 I = P3 Models (4/LVR)\*    \*\*Excluding P3 Hoists & P3 Combination units

**CONTROL LENGTH**

E = 5 FT    T = 20 FT  
 J = 10 FT    Y = 25 FT  
 O = 15 FT    Z = No Control Length

**VINTAGE**

A

**EXHAUST**

X = Standard Muffler  
 P = Piped Exhaust

**TROLLEY**

A = 2.62-6" Tapered  
 B = 2.62-6" S.R. Tapered  
 C = 2.62-6" Flat  
 D = 2.62-6" S.R. Flat  
 E = 2" NrW Flat  
 F = 2" S.R. NrW Flat  
 G = 6-8" Tapered  
 H = 6-8" S.R. Tapered  
 I = 6-8" Flat  
 J = 6-8" S.R. Flat

**CONNECTING LINK**

A = 300-1100 lbs. 2.66-4.66" H/T\*  
 B = 1500-4400 lbs. 3-6" H/T\*  
 C = K5 Series 2-5" Trolley  
 D = P1 Series 2-5" Trolley  
 E = P2 (11/15/22) 2-5" Trolley  
 F = P2 (30/44) 2-5" Trolley  
 L = P2 (11/15/22) 5-7" Trolley  
 M = P2 (30/44) 5-7" Trolley  
 G = K1 (66/88) & P3 (80) 4-6-25" Trolley  
 H = P3 (22/43) 3.33-6.25" Trolley  
 K = K1 (22/33/44) 2-6.25" Trolley  
 X = Standard Connecting Link

\*H/T = Hook type trolley

\*\*Code 'G' can be used with both Hook-type and trolley mounted Hoists (3.25-6.25"). Codes C-M to be used with existing trolley mounted hoists; A&B used with hook type trolleys

Note: Numbers in parentheses following an option, represent the hoist capacities for which that option is available.

**DRIVE ENGAGEMENT**

S = Spring for (04A/04N/12A/12N/24A/24N)  
 F = Free to Positive (2 or 4 lever)  
 for (04B/04M/12B/12M/24B/24M)  
 G = Free to Positive (3 or 5 lever)  
 for (04C/04O/12C/12O/24C/24O)  
 P = Positive to Free (3 or 5 lever)  
 for (04D/04P/12D/12P/24D/24P)

Note: Numbers and letters in parentheses following a Drive Engagement option, represent the Traversing Speed and Drive Wheel Type for which that Drive Engagement option is available.

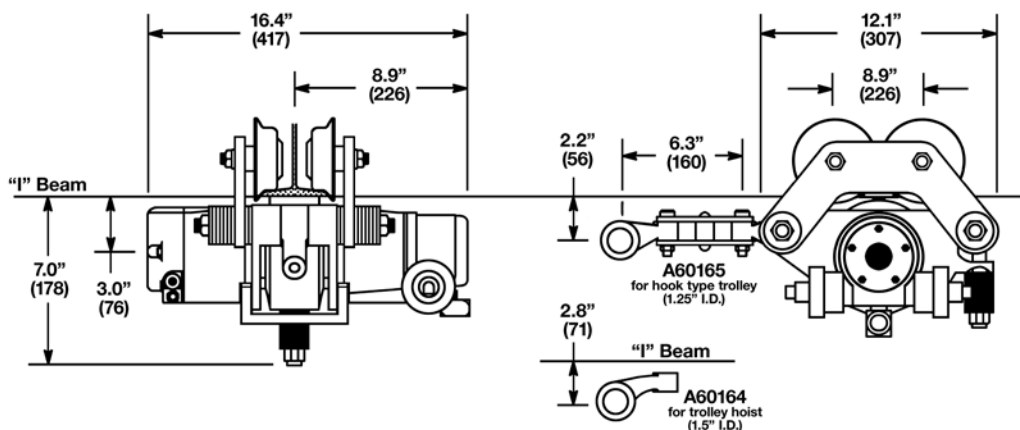

# Hoist/Hoisttractor Combination Units

K1 Series

## GARDNER-DENVER®

### K1 Series

**Capacity:**

2200-8800 lbs. 1000-4000 kg

**Beam flange width:**

2200 lbs., 3300 lbs., 4400 lbs. cap.

3.00-6.25 in 76-159 mm

6600 lbs., 8800 lbs. cap.

4.00-6.25 in 102-159 mm

**Minimum turning radius:**

2200 lbs., 3300 lbs., 4400 lbs. cap.

60 in 1254 mm

6600, 8800 lbs. cap.

72 in 1829 mm

- Rotary Vane Air Motor
- Pendant Control
- Link Chain



**Single Reeved**

2200 lbs. (1000 kg), 3300 lbs. (1500 kg)  
& 4400 lbs. (2000 kg) Capacity

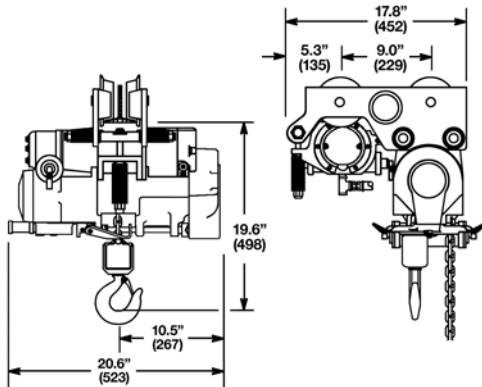

**Double Reeved**  
6600 lbs. (3000 kg) & 8800 lbs.  
(4000 kg) Capacity

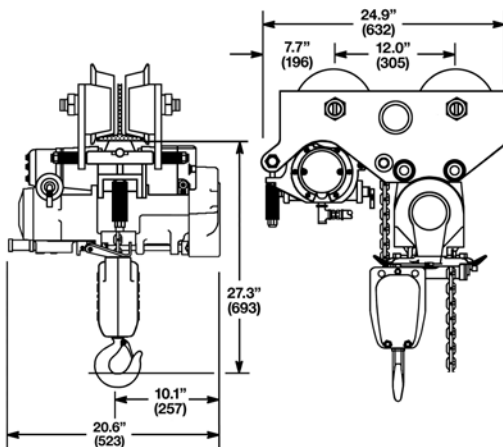



**K1 C A 22 L P E P --- A A A 22**

**SERIES**

K1

**TYPE MOUNT**

C = Combination

**FEATURES**

A = Standard Unit  
H = Hi Temp Grease  
P = Epoxy Paint  
S = Epoxy Paint/Hi Temp Grease

**CAPACITY**

22 = 2200 lbs.      66 = 6600 lbs.  
33 = 3300 lbs.      88 = 8800 lbs.  
44 = 4400 lbs.

**CHAIN TYPE**

L = Link

**CONTROL TYPE**

P = Pendant (w/Hoistractor-4LVR)  
W = Pendant Ready

**CONTROL LENGTH**

E = 5 FT      T = 20 FT  
J = 10 FT      Y = 25 FT  
O = 15 FT      Z = No Control Length

**CHAIN TYPE**

P = Zinc Plated Link  
X = No Chain

**CAPACITY RATING**

11 = 1100 lbs. (22/33/44)  
22 = 2200 lbs. (22/33/44)  
33 = 3300 lbs. (33/44)  
34 = 3300 lbs. (66)  
44 = 4400 lbs. (44)  
45 = 4400 lbs. (66/88)  
66 = 6600 lbs. (66/88)  
88 = 8800 lbs. (88)

**VINTAGE**

A

**LOWER HOOK**

A = Standard Link (22/33/44)  
B = Bullard Link (22/33/44)  
C = Standard Link (66/88)  
D = Bullard Link (66/88)  
X = No Lower Hook

**TROLLEY**

A = 3-6.25" Standard Speed, Tapered (22/33/44)  
B = 3-6.25" Standard Speed, Flat (22/33/44)  
C = 3-6.25" Slow Speed, Tapered (22/33/44)  
D = 3-6.25" Slow Speed, Flat (22/33/44)  
E = 3-6.25" High Speed, Tapered (22/33/44)  
F = 3-6.25" High Speed, Flat (22/33/44)  
G = 4-6.25" Standard Speed, Tapered (66/88)  
H = 4-6.25" Standard Speed, Flat (66/88)  
I = 3.25" Standard Speed, NrW (66/88)  
J = 4-6.25" Slow Speed, Tapered (66/88)  
K = 4-6.25" Slow Speed, Flat (66/88)  
L = 3.25" Slow Speed, NrW Flat (66/88)  
M = 4-6.25" High Speed, Tapered (66/88)  
N = 4-6.25" High Speed Flat (66/88)  
O = 3.25" High Speed NrW (66/88)

**AMOUNT OF LIFT**

--- Specify Length in Feet, 3 digits  
Example: 10' lift 010

Note: Numbers in parentheses following an option, represent the hoist capacities for which that option is available.

Model Number	Chain Type	Capacity		Lifting & Lowering Speeds				Traversing Speed		Reeves	Weight	
				Maximum Lift		Maximum Lower		fpm	mpm		lbs.	kg
Pendant Control		lbs.	kg	fpm	mpm	fpm	mpm	fpm	mpm		lbs.	kg
K1CA22LPEP010AAA22	Link	2200	1000	33	10	52	16	69	21	1	325	147
K1CA33LPEP010AAA33	Link	3300	1500	21	6	34	10	67	20	1	325	147
K1CA44LPEP010AAA44	Link	4400	2000	15	5	24	7	65	20	1	325	147
K1CA66LPEP010GCA66	Link	6600	3000	10	3	17	5	57	17	2	390	177
K1CA88LPEP010GCA88	Link	8800	4000	7	2	12	4	50	15	2	390	177

**General:**

Air Inlet: 1/2" NPT (use 3/4" I.D. Hose)  
Performance rated at 90 psig (6 bar/620 kPa) air pressure.  
Air Consumption:  
Hoist – 75 cfm (2.12 m<sup>3</sup>/min.) at rated load.  
Hoistractor – 30 cfm (.8 m<sup>3</sup>/min.) at rated load.

**Standard Equipment:**

Hoist/Hoistractor combination unit with 10 ft. (3.0m) lift  
Pendant Control: 5 ft. (1.5m) hose length

**Extra Equipment:**

Chain container – page 54-55  
Piped exhaust adapter (1/2" NPT) – 500344  
(3/4" NPT) – 536567

# Hoist/Hoisttractor Combination Units

P2 Series

## GARDNER-DENVER®

### P2 Series

Capacity:  
1100-4400 lbs. 500-2000 kg

Beam flange width:  
3.00-5.25 in 76-133 mm

Minimum turning radius:  
1100 lbs., 1500 lbs., 2200 lbs. cap.  
26 in 660 mm

3000 lbs., 4000 lbs. cap.  
42 in 1067 mm

- Axial Piston Air Motor
- Pendant Control
- Link Chain



#### Single Reeved

1100 lbs. (500 kg), 1500 lbs. (680 kg)  
& 2200 lbs. (1000 kg) Capacity

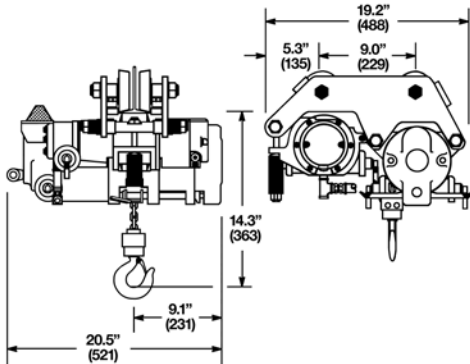

Double Reeved  
3000 lbs. (1360 kg) &  
4400 lbs. (2000 kg) Capacity

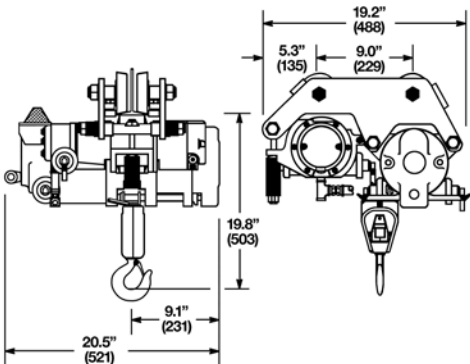

**P2 C A 11 L P E L --- A A A 11**

**SERIES**

P2

**TYPE MOUNT**

C = Combination

**FEATURES**

- A = Standard Unit
- E = Edible Grease
- H = Hi Temp Grease
- P = Epoxy Paint
- R = Epoxy Paint/Edible Grease
- S = Epoxy Paint/Hi Temp Grease

**CAPACITY**

- 10 = 1000 lbs.      22 = 2200 lbs.
- 11 = 1100 lbs.      30 = 3000 lbs.
- 15 = 1500 lbs.      44 = 4400 lbs.

**CHAIN TYPE**

L = Link

**CONTROL TYPE**

- P = Pendant (w/Hoistrator-4LVR)
- W = Pendant Ready

**CONTROL LENGTH**

- E = 5 FT              T = 20 FT
- J = 10 FT            Y = 25 FT
- O = 15 FT            Z = No Control Length

**CHAIN OPTIONS**

- L = Standard Link
- P = Zinc Plated Link
- Q = S.R. Link
- X = No Chain

**AMOUNT OF LIFT**

--- Specify Length in Feet, 3 digits  
Example: 10' Lift 010

**CAPACITY RATING**

- 03 = 300 lbs. (10/11/15)
- 05 = 500 lbs. (10/11/15)
- 10 = 1000 lbs. (10/11/15)
- 11 = 1100 lbs. (10/11/15)
- 15 = 1500 lbs. (15/22)
- 20 = 2000 lbs. (22)
- 22 = 2200 lbs. (22)
- 30 = 3000 lbs. (30/44)
- 31 = 1100 lbs. (30)
- 32 = 2200 lbs. (30/44)
- 40 = 4000 lbs. (44)
- 44 = 4400 lbs. (44)

**VINTAGE**

A

**LOWER HOOK**

- A = Standard (11/22)      F = S.R. Bullard (30)
- B = Bullard (11/22)      G = Standard (44)
- C = S.R. Std. (10/15)    H = Bullard (44)
- D = S.R. Bullard (10/15) X = No Hook
- E = S.R. Std. (30)

**TRACTOR/TROLLEY**

- A = 3-5.25" Std. Speed Tapered (11/22/44)
- B = 3-5.25" Std. Speed Flat (11/22/44)
- C = 3-5.25" Std. Speed S.R. Tapered (10/15/30)
- D = 3-5.25" Std. Speed S.R. Flat (10/15/30)
- E = 3-5.25" Slow Speed Tapered (11/22/44)
- F = 3-5.25" Slow Speed Flat (11/22/44)
- G = 3-5.25" Slow Speed S.R. Tapered (10/15/30)
- H = 3-5.25" Slow Speed S.R. Flat (10/15/30)
- I = 3-5.25" High Speed Tapered (11/22/44)
- J = 3-5.25" High Speed Flat (11/22/44)
- K = 3-5.25" High Speed S.R. Tapered (10/15/30)
- L = 3-5.25" High Speed S.R. Flat (10/15/30)
- M = 5-7" Std. Speed Tapered (11/22/44)
- N = 5-7" Std. Speed Flat (11/22/44)
- O = 5-7" Std. Speed S.R. Tapered (10/15/30)
- P = 5-7" Std. Speed S.R. Flat (10/15/30)
- Q = 5-7" Slow Speed Tapered (11/22/44)
- R = 5-7" Slow Speed Flat (11/22/44)
- S = 5-7" Slow Speed S.R. Tapered (10/15/30)
- T = 5-7" Slow Speed S.R. Flat (10/15/30)
- U = 5-7" High Speed Tapered (11/22/44)
- V = 5-7" High Speed Flat (11/22/44)
- W = 5-7" High Speed S.R. Tapered (10/15/30)
- Y = 5-7" High Speed S.R. Flat (10/15/30)

Note: Numbers in parentheses following an option, represent the hoist capacities for which that option is available.

Model Number	Chain Type	Capacity		Lifting & Lowering Speeds				Traversing Speed		Reeves	Weight	
		lbs.	kg	Maximum Lift		Maximum Lower		fpm	mpm		lbs.	kg
P2CA11LPEL010AAA11	Link	1100	500	34	10	107	33	70	21	1	145	66
P2CA22LPEL010AAA22	Link	2200	1000	17	5	56	17	69	21	1	170	77
P2CA44LPEL010AGA44	Link	4400	2000	9	3	28	9	65	20	2	202	92
<b>Spark Resistant Units</b>												
P2CA15LPEQ010CCA15	Link	1500	680	23	7	58	18	70	21	1	170	77
P2CA30LPEQ010CEA30	Link	3000	1360	11	3	26	8	65	20	2	202	92

**General:**

- Air Inlet: 3/8" NPT (use 5/8" I.D. Hose)
- Performance rated at 90 psig (6 bar/620 kPa) air pressure.
- Air Consumption:
  - Hoist – 44 cfm (1.2 m<sup>3</sup>/min.) at rated load.
  - Hoistractor – 30 cfm (.8 m<sup>3</sup>/min) at rated load.

**Standard Equipment:**

- Hoist/Hoistractor combination unit with 10 ft. (3.0m) lift
- Pendant Control: 5 ft. (1.5m) hose length

**Extra Equipment:**

- Chain container – page 54-55
- Additional Pendant Control hose lengths (specify when ordering)
- Piped exhaust adapter (1/2" NPT) – 500344
- (3/4" NPT) – 535779

# Hoist/Hoistactor Combination Units

P3 Series

## GARDNER-DENVER®

### P3 Series

Capacity:  
2200-8000 lbs. 1000-3629 kg

Beam flange width:  
2200 lbs., 4300 lbs. capacity  
3.38-6.25 in 86-159 mm

8000 lbs. capacity  
4.00-6.25 in 102-159 mm

Minimum turning radius:  
2200 lbs., 4300 lbs. capacity  
72 in 1829 mm

8000 lbs. capacity  
72 in 1829 mm

- Axial Piston Air Motor
- Pendant Control
- Link Chain

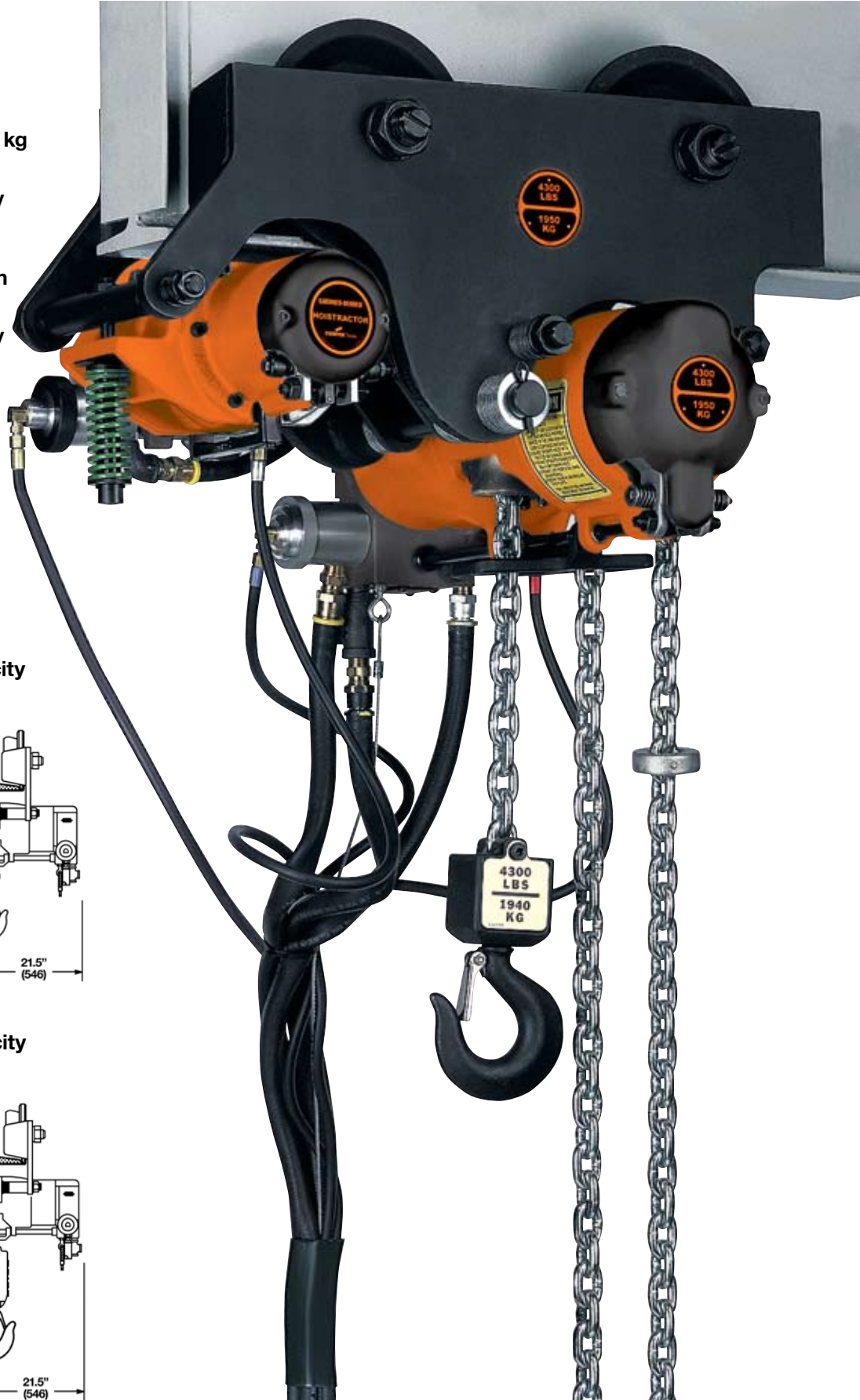

Single Reeved  
2200 lbs. (1000 kg) &  
4300 lbs. (1950 kg) Capacity

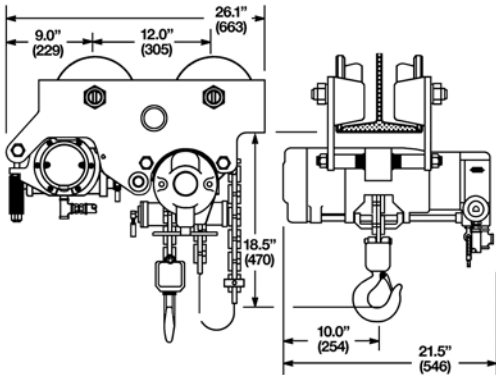

Double Reeved  
8000 lbs. (3629 kg) Capacity

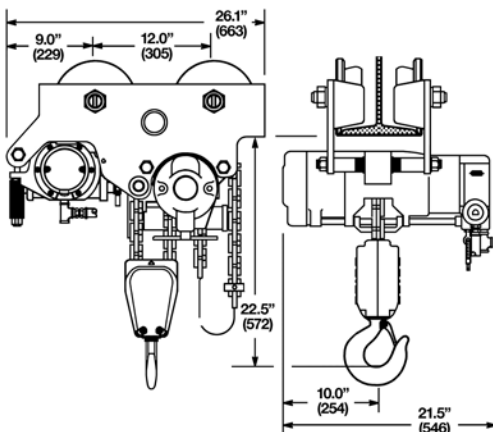



**P3 C A 22 L P E P --- A A A 22**

**SERIES**

P3

**TYPE MOUNT**

C = Combination

**FEATURES**

A = Standard Unit  
 H = Hi Temp Grease  
 P = Epoxy Paint  
 S = Epoxy Paint/Hi Temp Grease

**CAPACITY**

22 = 2200 lbs.  
 43 = 4300 lbs.  
 80 = 8000 lbs.

**CHAIN TYPE**

L = Link

**CONTROL TYPE**

P = Pendent Standard  
 X = None-Pendent Ready

**CONTROL LENGTH**

E = 5 FT            T = 20 FT  
 J = 10 FT         Y = 25 FT  
 O = 15 FT         Z = No Control Length

**CHAIN OPTIONS**

P = Zinc Plated Link  
 X = No Chain

**CAPACITY RATING**

11 = 1100 lbs. (22)  
 20 = 2000 lbs. (22/43)  
 22 = 2200 lbs. (22/43)  
 40 = 4000 lbs. (43)  
 43 = 4300 lbs. (43)  
 50 = 5000 lbs. (80)  
 60 = 6000 lbs. (80)  
 80 = 8000 lbs. (80)

**VINTAGE**

A

**LOWER HOOK**

A = Standard (22/43)  
 B = Bullard (22/43)  
 C = Standard (80)  
 D = Bullard (80)  
 X = No Lower Hook

**TROLLEY**

A = 4-6.25" Standard Speed Tapered (22/43/80)  
 B = 4-6.25" Standard Speed Flat (22/43/80)  
 C = 3.25-3.33" Nrwr Flat (22/43/80) Std.  
 D = 4-6.25" Slow Speed Tapered (22/43/80)  
 E = 4-6.25" Slow Speed Flat (22/43/80)  
 F = 3.25-3.33" Slow Speed Nrwr Flat (922/43/80)  
 G = 4-6.25" High Speed Tapered (22/43/80)  
 H = 4-6.25" High Speed Flat (922/43/80)  
 I = 3.25-3.33" High Speed Nrwr Flat (22/43/80)

**AMOUNT OF LIFT**

--- Specify Length in Feet, 3 digits  
 Example: 10' Lift 010

Note: Numbers in parentheses following an option, represent the hoist capabilities for which that option is available.

Model Number	Chain Type	Capacity		Lifting & Lowering Speeds				Traversing Speed		Reeves	Weight	
				Maximum Lift		Maximum Lower		fpm	mpm		lbs.	kg
Pendent Control		lbs.	kg	fpm	mpm	fpm	mpm	fpm	mpm		lbs.	kg
P3CA22LPEP010AAA22	Link	2200	1000	30	9	80	24	69	21	1	325	147
P3CA43LPEP010AAA43	Link	4300	1950	15	5	40	12	65	20	1	325	147
P3CA80LPEP010ACA80	Link	8000	3629	7	2	20	6	55	17	2	365	166

**General:**

Air Inlet: 1/2" NPT (use 3/4" I.D. Hose)  
 Performance rated at 90 psig (6 bar/620 kPa) air pressure.  
 Air Consumption:  
 Hoist – 83 cfm (2.35 m<sup>3</sup>/min.) at rated load.  
 Hoistactor – 30 cfm (.8 m<sup>3</sup>/min) at rated load.

**Standard Equipment:**

Hoist/Hoistactor combination unit with 10 ft. (3.0m) lift  
 Pendent Control: 5 ft. (1.5m) hose length

**Extra Equipment:**

Chain container – page 54-55

# Hoist/Hoistactor Combination (Low Headroom)

P3 Series

## GARDNER-DENVER®

### P3 Series

Capacity:  
2200-4300 lbs. 1000-1950 kg

Beam flange width:  
3.00-4.00 in 76-102 mm

Minimum turning radius:  
60 in 1524 mm

- Axial Piston Air Motor
- Pendant Control
- Link Chain

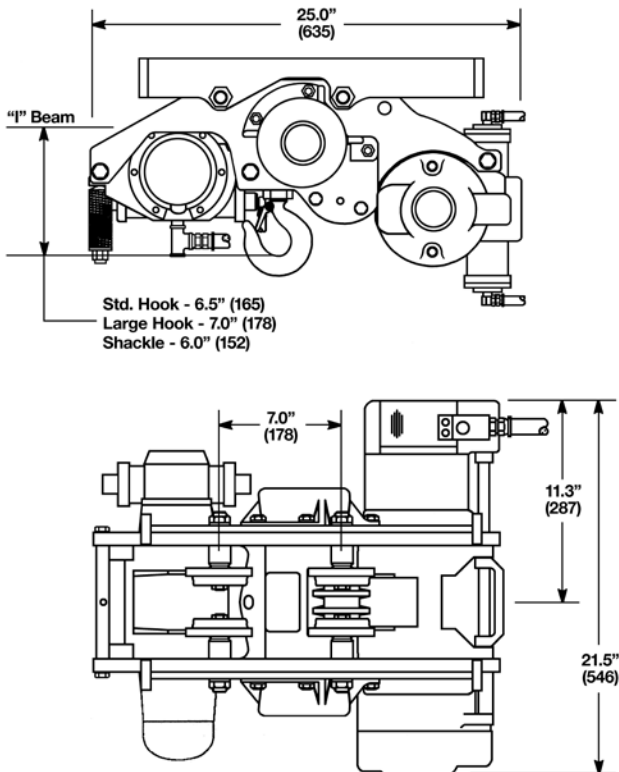
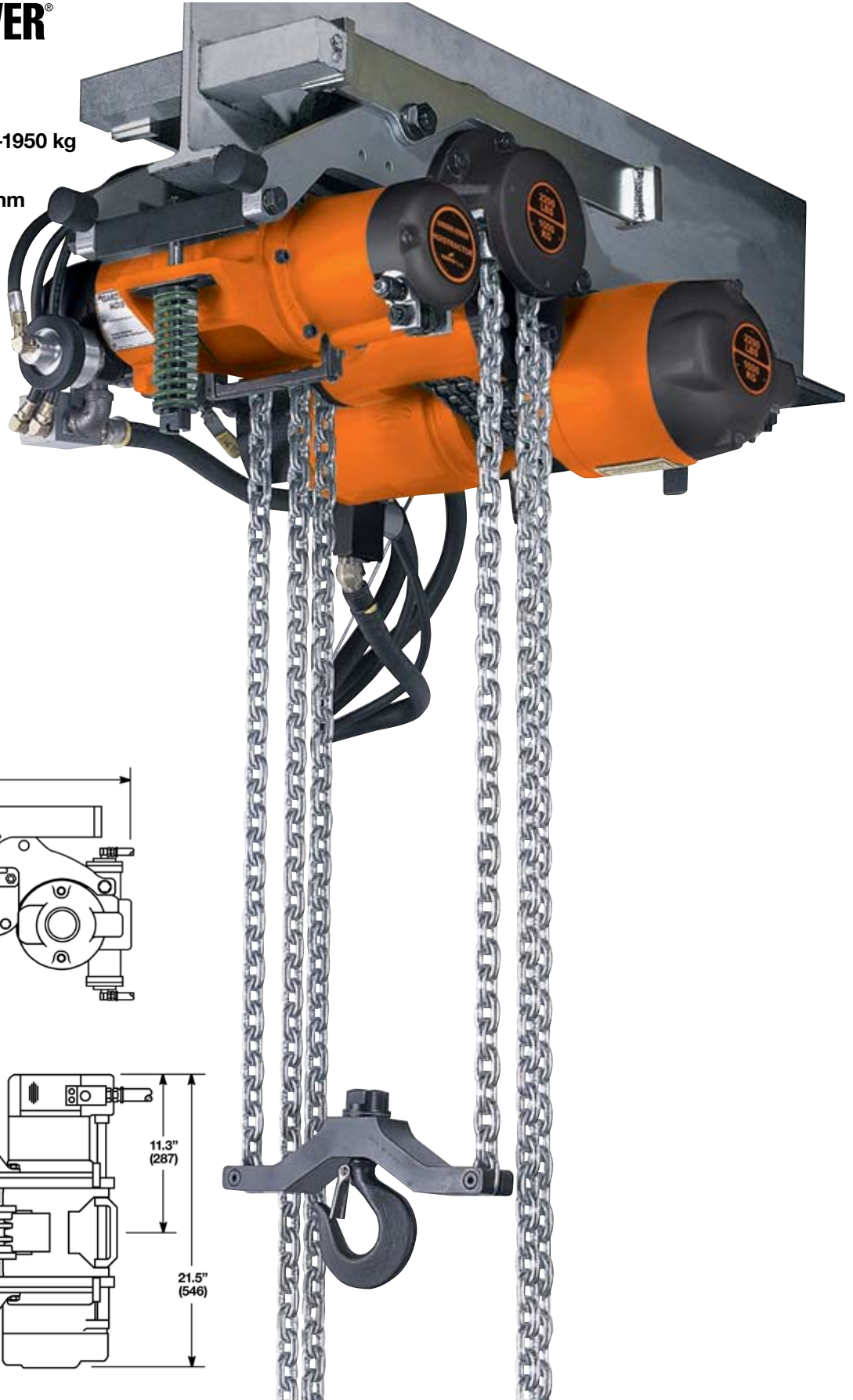

**P3 N A 22 L P E P 010 A A A 22**

**SERIES**  
P3

**TYPE MOUNT**  
N = Combination Unit (Low Headroom)

**FEATURES**  
A = Standard Unit  
H = Hi Temp Grease  
P = Epoxy Paint  
S = Epoxy Paint/Hi Temp Grease

**CAPACITY**  
22 = 2200 lbs.  
43 = 4300 lbs.

**CHAIN TYPE**  
L = Link

**CONTROL TYPE**  
P = Pendent Standard

**CONTROL LENGTH**  
E = 5 FT                              T = 20 FT  
J = 10 FT                             Y = 25 FT  
O = 15 FT                            Z = No control length

**CHAIN OPTIONS**  
P = Zinc Plated Link

**CAPACITY RATING**  
10 = 1000 lbs. (22)  
15 = 1500 lbs. (22)  
20 = 2000 lbs. (22/43)  
22 = 2200 lbs. (22/43)  
40 = 4000 lbs. (43)  
43 = 4300 lbs. (43)

**VINTAGE**  
A

**LOWER SUPPORT**  
A = Std. Hook (1-1/8" opening)  
B = Large Hook (1-11/32" opening)  
C = Shackle (1-1/6" W x 1" H opening)

**TRACTOR/TROLLEY**  
Standard  
A = STD SPD/Taper (22/43)  
B = STD SPD/Flat (22/43)  
D = Slow SPD/Taper (22/43)  
E = Slow SPD/Flat (22/43)  
G = Hi-Spd. Taper (22/43)  
H = Hi-Spd Flat (22/43)  
High Temp Grease  
I = STD SPD, Taper (22/43)  
J = STD SPD, Flat (22/43)  
K = Slow SPD, Taper (22/43)  
L = Slow SPD, Flat (22/43)  
M = Hi Spd., Taper (22/43)  
N = Hi Spd, Flat (22/43)

**AMOUNT OF LIFT**  
--- Specify Length in Feet, 3 digits  
Example: 10' Lift 010

Note: Numbers in parentheses following an option, represent the hoist capabilities for which that option is available.

Model Number	Chain Type	Capacity		Lifting & Lowering Speeds				Traversing Speed		Reeves	Weight	
				Maximum Lift		Maximum Lower		fpm	mpm		lbs.	kg
Pendent Control		lbs.	kg	fpm	mpm	fpm	mpm	fpm	mpm		lbs.	kg
P3NA22LPEP010AAA22	Link	2200	1000	30	9	80	24	69	21	1	225	102
P3NA43LPEP010AAA43	Link	4300	1950	15	5	40	12	65	20	1	225	102

**General:**

Air Inlet: 1/2" NPT (use 3/4" I.D. Hose)  
Performance rated at 90 psig (6 bar/620 kPa) air pressure.  
Air Consumption:  
Hoist – 83 cfm (2.35 m<sup>3</sup>/min.) at rated load.  
Hoist tractor – 30 cfm (.8 m<sup>3</sup>/min) at rated load.

**Standard Equipment:**

Hoist/Hoist tractor combination unit with 10 ft. (3.0m) lift  
Pendent Control: 5 ft. (1.5m) hose length

**Extra Equipment:**

Chain container – page 54-55



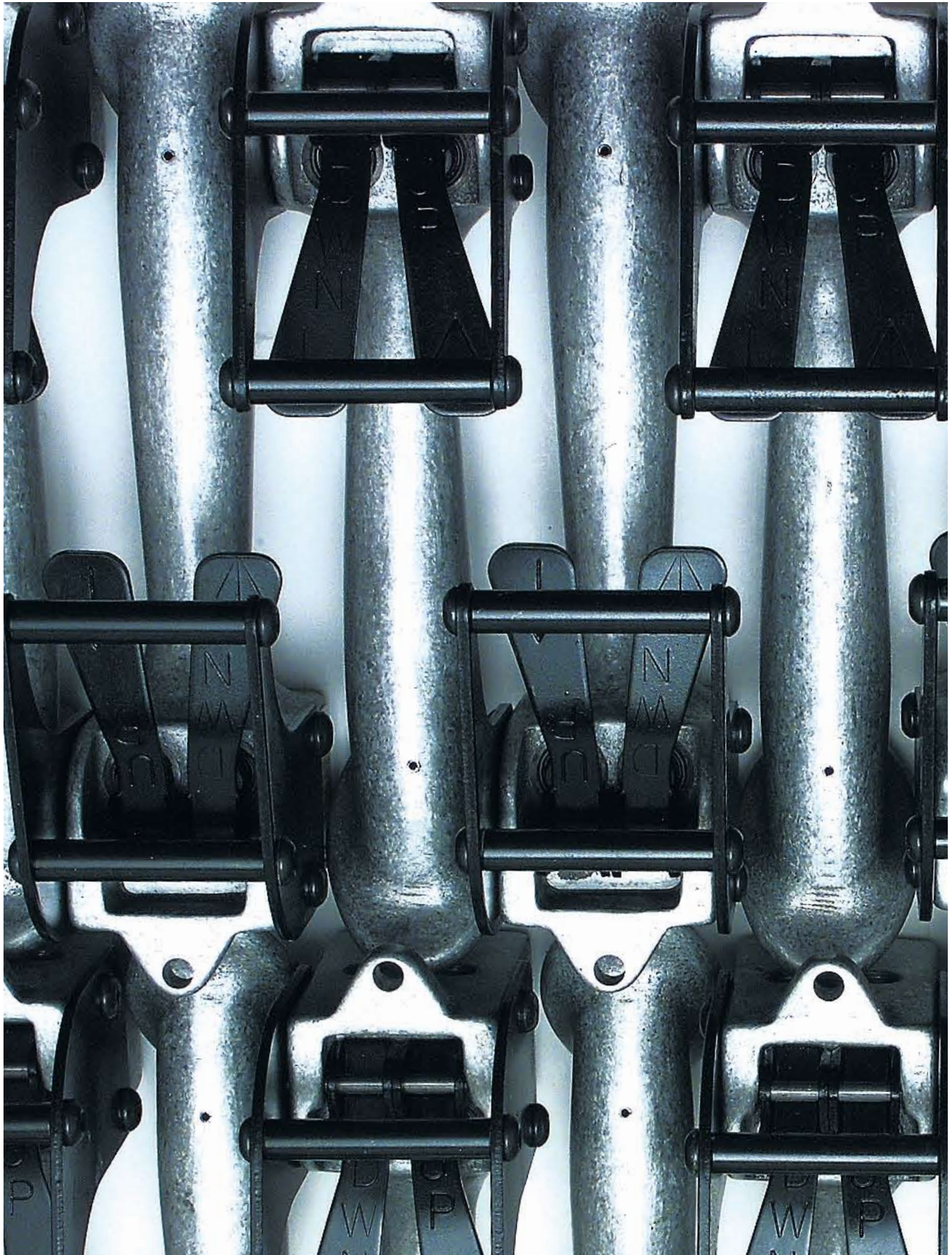



### S-Beams (tapered)

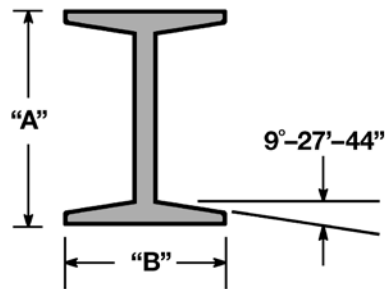

### W-Beams (flat)

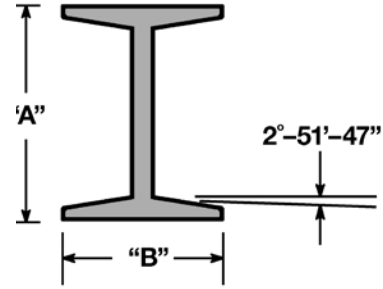

Standard Size Height ("A")		Weight per Foot		Beam Flange width ("B")	
in.	mm	lbs.	kg	in.	mm

#### American Standard "I" Beam Sizes

4	101.6	7.70	3.49	2.660	67.564
4	101.6	9.50	4.31	2.796	71.018
5	127.0	10.00	4.54	3.000	76.200
5	127.0	14.75	6.69	3.284	83.414
6	152.4	12.50	5.67	3.330	84.582
6	152.4	17.25	7.82	3.565	90.551
7	177.8	15.30	6.94	3.660	92.964
7	177.8	20.00	9.07	3.860	98.044
8	203.2	28.40	8.35	4.000	101.600
8	203.2	23.00	10.43	4.171	105.943
10	254.0	25.40	11.34	4.660	118.364
10	254.0	35.00	15.88	4.944	125.578
12	304.8	31.80	14.06	5.000	127.000
12	304.8	35.00	15.88	5.078	128.981
12	304.8	40.80	18.51	5.250	133.350
12	304.8	50.00	22.68	5.477	139.116
15	381.0	42.90	19.46	5.500	139.700
15	381.0	50.00	22.68	5.640	143.256
18	457.2	54.70	24.81	6.000	152.400
18	457.2	70.00	31.75	6.251	158.775
20	508.0	65.90	29.67	6.250	158.750
20	508.0	75.00	34.02	6.391	162.331
20	508.0	85.00	38.56	7.053	179.146
20	508.0	95.00	43.09	7.200	182.880
24	609.6	79.90	36.24	7.000	177.800
24	609.6	90.00	40.82	7.124	180.950
24	609.6	100.00	45.36	7.247	184.074
24	609.6	105.90	48.04	7.875	200.025
24	609.6	120.00	54.43	8.048	204.419

Standard Size Height ("A")		Flange Type*	Weight per Foot		Beam Flange width ("B")	
in.	mm		lbs.	kg	in.	mm

#### W or Wide Flange "I" Beam Sizes

6	152.4	(B)	10	4.55	3.000	76.200
7	177.8	(B)	12	5.44	3.500	88.900
8	203.2	(WF)	17	7.71	5.250	133.350
8	203.2	(WF)	20	9.07	5.268	133.807
10	254.0	(WF)	21	9.53	5.750	146.050
10	254.0	(WF)	25	11.34	5.762	146.355
10	254.0	(WF)	29	13.15	5.799	147.295
12	302.8	(WF)	21	9.53	6.500	165.100
12	304.8	(WF)	31	14.06	6.525	165.735
12	304.8	(WF)	36	16.33	6.565	166.751
14	355.6	(WF)	30	13.61	6.733	171.018
14	355.6	(WF)	34	15.42	6.750	171.450
14	355.6	(WF)	38	17.24	6.776	172.110
16	406.4	(WF)	36	16.33	6.992	177.597
16	406.4	(WF)	40	18.14	7.000	177.800
16	406.4	(WF)	45	20.41	7.039	178.791
16	406.4	(WF)	50	22.68	7.073	179.654
16	406.4	(WF)	58	26.31	8.464	214.986
16	406.4	(WF)	64	29.03	8.500	215.900
16	406.4	(WF)	71	32.21	8.543	216.992
16	406.4	(WF)	78	35.38	8.586	218.084
18	457.2	(WF)	50	22.68	7.500	190.500
18	457.2	(WF)	55	24.95	7.532	191.313
18	457.2	(WF)	60	27.22	7.558	191.973
18	457.2	(WF)	64	29.03	8.715	221.361
18	457.2	(WF)	70	31.75	8.750	222.250
18	457.2	(WF)	77	34.93	8.787	223.190
18	457.2	(WF)	85	38.56	8.838	224.485
21	533.4	(WF)	62	28.12	8.240	209.296
21	533.4	(WF)	68	30.84	8.270	210.058
21	533.4	(WF)	73	33.11	8.295	210.693
21	533.4	(WF)	82	37.20	8.962	227.635
21	533.4	(WF)	96	43.55	9.038	229.565
24	609.6	(WF)	76	34.47	8.985	228.219
24	609.6	(WF)	84	38.10	9.015	228.981
24	609.6	(WF)	94	42.64	9.061	230.149
24	609.6	(WF)	100	45.36	12.000	304.800
24	609.6	(WF)	110	49.90	12.042	305.867
24	609.6	(WF)	112	50.80	12.068	307.035

These charts show common standard beam sizes, weights, and flange widths for both American standard section "I" beams and wide flange shapes (as listed by the American Institute of Steel Construction). Always include beam sizes when ordering trolley hoists.

**NOTE:**

Carnegie 24" WF beams of these weights have straight flanges.

\*(WF) = Wide Flange

# Accessories & Replacement Parts

## Chain Containers

### How to order a chain container:

1. Identify chain type, hoist series, and hoist capacity for which the chain container is to be used.
2. Determine the required lift and select the applicable part number.

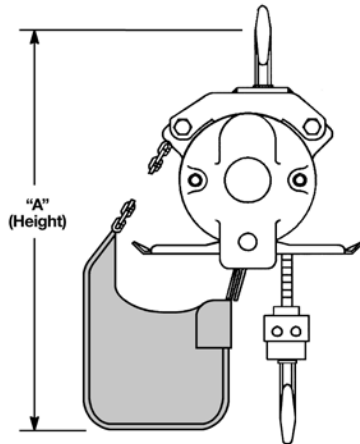

Metal Type Chain Container Shown



Link Chain model shown.

## Roller Chain Containers

Hoist Series	Part Number	Hoist Capacity (lbs.)							
		550 & 1100		2200		550 & 1100		2200	
		Lift				"A" (Height)			
		ft.	M	ft.	M	in.	mm	in.	mm
K5	535028	10	3.0			22.5	572		
K5	535029	20	6.1	10	3.0	30.6	777	31.5	800
K5	535031	40	12.2	20	6.1	44.8	1138	45.8	1163

Hoist Series	Part Number	Hoist Capacity (lbs.)							
		300, 500 & 1000		2000		300, 500 & 1000		2000	
		Lift				"A" (Height)			
		ft.	M	ft.	M	in.	mm	in.	mm
P1	533664	15	4.6			24.0	610		
P1	533665	25	7.6	12	3.7	32.5	826	33.1	841
P1	533666	40	12.2	20	6.1	42.5	1080	43.1	1095
P1	533667	55	16.8	27	8.2	52.5	1334	53.1	1349

### Spark Resistant

P1	A299101	10	3.0			19.8	503		
P1	A299102	15	4.6			24.0	610		
P1	A299103	20	6.1			28.3	719		

Hoist Series	Part Number	Hoist Capacity (lbs.)							
		1100 & 2200		4400		1100 & 2200		4400	
		Lift				"A" (Height)			
		ft.	M	ft.	M	in.	mm	in.	mm
P2	533664	12	3.7			27.3	693		
P2	533665	20	6.1	10	3.0	36.8	935	37.3	947
P2	533666	30	9.1	15	4.6	45.8	1163	47.3	1201
P2	533667	40	12.2	20	6.1	55.8	1417	57.3	1455

Chain Container nominal width: 11" (279 mm)

\*Canvas type chain container

# Link Chain Containers

Hoist Series	Part Number	Hoist Capacity (lbs.)							
		550 & 1100		2200		550 & 1100		2200	
		Lift				"A" (Height)			
		ft.	M	ft.	M	in.	mm	in.	mm
K5	535302	25	7.6	12	3.7	21.7	551	22.5	572
K5	527410*	30	9.1	15	4.6	20.0	508	20.9	531
K5	535304	45	13.7	22	6.7	26.3	668	27.3	693
K5	527277*	60	18.3	30	9.1	40.0	1016	40.9	1039
K5	535306	65	19.8	32	9.8	32.3	820	32.3	820

Chain Container nominal width: Metal type: 8.5" (216 mm)  
Canvas type: 4.3" (109 mm)

Hoist Series	Part Number	Hoist Capacity (lbs.)									
		2200, 3300 & 4400		6600 & 8800		2200		3300 & 4400		6600 & 8800	
		Lift				"A" (Height)					
		ft.	M	ft.	M	in.	mm	in.	mm	in.	mm
K1	532275*	20	6.1	10	3.0	27.7	704	28.4	721	31.8	808
K1	534907	20	6.1	10	3.0	28.6	726	29.3	744	32.6	828
K1	532276*	30	9.1	15	4.6	32.7	831	33.4	848	36.8	935
K1	532277*	40	12.2	20	6.1	37.7	958	38.4	975	41.8	1062
K1	534908	40	12.2	20	6.1	33.6	853	34.3	871	37.6	955
K1	534909	60	18.3	30	9.1	37.7	958	38.4	975	41.8	1062
K1	535070	80	24.4	40	12.2	43.7	1110	44.4	1128	47.8	1214
K1	539797	95	29.0	47	14.3	47.2	1199	47.9	1217	51.3	1303

Hoist Series	Part Number	Hoist Capacity (lbs.)							
		300, 500 & 1000		2000		300, 500 & 1000		2000	
		Lift				"A" (Height)			
		ft.	M	ft.	M	in.	mm	in.	mm
P1	A25190	12	3.7	-	-	17.2	437	-	-
P1	533521	30	9.1	15	4.6	19.3	490	19.9	505
P1	539415*	30	9.1	15	4.6	18.6	472	19.2	589
P1	533523	50	15.2	25	7.6	24.0	610	24.6	625
P1	539416*	60	18.3	30	9.1	24.6	625	25.2	640
P1	533520	15	4.6	-	-	17.1	434	-	-
P1	533525	70	21.3	35	10.7	29.0	737	29.6	752

Hoist Series	Part Number	Hoist Capacity (lbs.)							
		1100 & 2200		4400		1100 & 2200		4400	
		Lift				"A" (Height)			
		ft.	M	ft.	M	in.	mm	in.	mm
P2	533520	14	4.3	-	-	20.2	513	-	-
P2	533521	20	6.1	10	3.0	22.4	569	23.9	607
P2	539415*	25	7.6	12	3.7	21.7	551	23.2	589
P2	533523	40	12.2	20	6.1	27.1	688	28.6	726
P2	539416*	40	12.2	20	6.1	27.7	704	29.2	742
P2	533525	60	18.3	30	9.1	32.1	815	33.6	853

## Spark Resistant

P2	533527	20	6.1	10	3.0	22.4	569	23.9	607
P2	533529	40	12.2	20	6.1	27.1	688	28.6	726
P2	533531	60	18.3	30	9.1	32.1	815	33.6	853

Hoist Series	Part Number	Hoist Capacity (lbs.)							
		2200 & 4300		8000		2200 & 4300		8000	
		Lift				"A" (Height)			
		ft.	M	ft.	M	in.	mm	in.	mm
P3	516648*	20	6.1	10	3.0	28.0	711	31.4	798
P3	537490	20	6.1	10	3.0	29.0	737	32.4	823
P3	516611*	30	9.1	15	4.6	33.0	838	35.4	899
P3	516649*	40	12.2	20	6.1	38.0	965	40.4	1026
P3	537491	40	12.2	20	6.1	34.0	864	37.4	950
P3	537492	60	18.3	30	9.1	40.0	1016	43.4	1102

## P3 Low Headroom

P3	533591*	20	6.1			16.0	406		
P3	533592*	40	12.1			19.5	495		

Chain Container nominal width: K1 Series: 7.5" (191 mm) P1, P2, P3 Series: 8.5" (216 mm)

\*Canvas type Chain Container

### Hooks

#### How to order a hook:

1. Identify hoist series and capacity for which hooks are to be used.
2. Determine chain type and required hook opening.
3. Determine chain type or latch/gate replacement.
4. Select hook and the applicable part number.

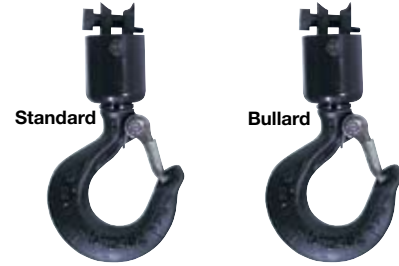

**WARNING: Failure to use the proper hook may result in operator injury or damage to the workpiece.**

Hoist Capacity (lbs.)	*Hook Type	Hook Opening (inches)	Link Chain			Roller Chain			Latch/Gate Replacement		
			Upper Hook	Lower Hook	Lower Hook Asm.	Upper Hook	Lower Hook	Lower Hook Asm.	Crosby (old)	Crosby (new)	Bullard Gate Kit
<b>Hoist Series 7</b>											
275	STD	7/8			532361					507523	542390
275	STD	15/16	540831							540832	540832
<b>Hoist Series K5</b>											
550/1100	STD	1-1/8	523386			523386			A27352		
550/1100	STD	15/16		530222			530222		A27305	540832	
550/1100	B	1-1/4	526329			526329					526567
550/1100	B	1-1/32		529455			529455				526566
2200	STD	1-1/8	523385	523443	523390	523385	A26061	534932	A27352	542388	
2200	B	1-1/4	526331	526327	526326	526331	A29919	535092			526567
<b>Hoist Series K1</b>											
2200	STD	1-11/32	528710	531008	531852				507938	542386	
2200	B	1-1/2	531763	531766	531768						528618
3300	STD	1-11/32	528710	531008	531853				507938	542386	
3300	B	1-1/2	531763	531766	531769						528618
4400	STD	1-11/32	528710	531008	531854				507938	542386	
4400	B	1/1/2	531763	531766	531770						526618
6600	STD	1-11/16	530232	530228	530371				516719	542389	
6600	B	1-7/8	531764	531767	531773						528618
8800	STD	1-11/16	530232	530228	530362				516719	542389	
8800	B	1-7/8	531764	531767	531774						528618
<b>Hoist Series P1</b>											
300/500/1000	STD**	7/8		539224					507523	542390	
300/500/1000	STD	15/16	539500	A20705S		539500	A10781S		A27305	540832	
500	SR	15/16	539557			539557	A17247S		A27305		
300/500/1000	B	1-1/32	539558	A29935		539558	A29934				526566
2000	STD	1-1/8	500374	A26061	AA27103	500374	A26061	AA26061	A27352	542388	
1000	SR	1-1/8							A27352	542406	
2000	B	1-1/4	505109	A29919	AA30728	505109	A29919	AA29919			526567
<b>Hoist Series P2</b>											
1100/2200	STD	1-1/8	541145	532074	533196	541145	532074	533197	A27352	542388	
1100/2200	B	1/14	541146	533167	533192	533163	533167	533193			526567
1500	SR	1-1/8	541189	532146	533490				A27352	542406	
1500	B/SR	1-1/4	533188	533170	533194						526567
3000	SR	1-11/32	542355	532194	532156				507938	542407	
3000	B/SR	1-1/2	542356	533156	533157						528618
4400	STD	1-11/32	542378	532177	532155	532164	532177	532162	507938	542386	
4400	B	1-1/2	542342	533153	533154	533160	533155	533155			528618
<b>Hoist Series P3</b>											
2200	STD	1-11/32	531129						507938	542386	
2200	STD	1-11/32		531008					507938	542386	
2200	B	1-1/2	537266	531766	531768						528618
4300	STD	1-11/32	531129	531008	531776				507938	542386	
4300	B	1-1/2	537266	531766							528618
8000	STD	1-11/16	531874	530228	531085				516719	542389	
8000	B	1-7/8	537266	531767	531775						528618

\*B = Bullard; SR = Spark Resistant; STD = Standard

\*\*Trolley Mounted Only



## Filters, Lubricators

### Modular Construction

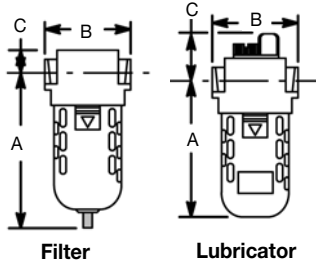

## Modular Sleeve & Bracket

(with O-Ring)

**Model:** MS-102  
Combination sleeve/wall mounting bracket as shown. Designed for mounting a single unit or combination of units directly to the wall. The sleeve and mounting bracket can be ordered assembled at the factory, or just the mounting bracket alone to be used on existing modular sleeves.



Model Number	NPT	Air Flow		Bowl Capacity		"A"		"B"		"C"	
	in.	SCFM	m <sup>3</sup> /min	oz.	liter	in.	mm	in.	mm	in.	mm

### Filters

F02-M	1/4	35	9.9	5.0	0.15	5.6	142	3.0	76	0.9	23
F03-M	3/8	44	12.9	5.0	0.15	5.6	142	3.0	76	0.9	23

### Lubricators – Economist (Standard Mist)

L03-EP	3/8	48	6.2	5.0	0.15	4.8	122	3.0	76	1.6	41
--------	-----	----	-----	-----	------	-----	-----	-----	----	-----	----

## Lubricants

Part Number	Size	Description	M.S.D.S. No.
-------------	------	-------------	--------------

### Oils

540397	1 qt. plastic	Air Line Oil	CPT-153
533485	1 gal. metal	Air Line Oil	CPT-153
536333	1 gal. metal	High Film Strength Air Line Oil	CPT-154
535577	8 oz. tube	Hoist Chain Oil	CPT-152

### Greases

A123771	16 oz. can	Piston Hoist Motor (P1, P2, P3). Hoistractor (TA)	CPT-142
518569	12 oz. can	Edible Grease	CPT-150
525430	16 oz. can	Hoist and Hoistractor Gearing	CPT-143
540450	16 oz. can	High Temp Grease for Piston Hoists (P1, P2, P3)	CPT-151

**NOTE:** Under normal conditions of use, lubrication products sold separately for or used within these tools should not cause an exposure hazard. Refer to the Material Safety Data Sheet (M.S.D.S.) for Safety and Disposal Information. M.S.D.S. sheets shown in the above chart are available upon request from Cooper PowerTools.

Hoist/Hoistractor Series	Drops Per Minute
<b>Air Line Lubrication</b>	
7	4 to 5
K5	8 to 10
K1	8 to 10
P1 & TA	3 to 4
P2	5 to 7
P3	8 to 10

### LUBRICATION:

The recommended drops per minute (shown in the Air Line Lubrication table at the left) is for use with Cooper PowerTools' Economist Lubricators. Use 540397, 533485, or 536333 air line oil.

## Flow Control Valve

Reduces lifting, lowering, or traversing speeds (used with P1 & TA models).



Part Number	Description
502905	3/8" NPT (inlet)

## Auxiliary Cable

(Backup Suspension for Hook and Lug Mounted Units)

Used with "Hook" and "Lug" mounted hoists. Cable inserts through a hole in hoist housing (K5, K1, P1 Models) or through the hook bracket (P2, P3 Models) and around the "I" beam or other support. The auxiliary cable is capable of supporting the hoist and hoist rated load weight.



Hoist Series	Hoist Capacity	Part Number
K5	All	520277
K1	2200, 3300	520277
K1	4400, 6600, 8800	520277 & •A19791
P1	All	520276
P2	1100, 1500, 2200, 3000	520277
P2	4400	520277 & •A19791
P3	2200	520277
P3	4300, 8800	520277 & •A19791

## Air Pressure Gage Kit

Part Number	Description
A13157	Gage, needle, cap & case



## Service Tools

Hoist Model	Part No.	Description
P1	525209	Valve Guide
P2	525208	Valve Guide



# Accessories & Replacement Parts

Pendent Controls, Hose Assemblies & Chain

## Pendent Control Handles and Hose Assemblies

### How to order a pendent control handle and hose assembly:

1. Identify hoist series and configuration for which the pendent control is to be used.
2. Select the pendent control part number.
3. Determine the required length of hose assembly and select applicable part number.



Hoist Configuration	Pendent Control Handles					Pendent Control Hose Assemblies						
	No. of Levers	Part No.	Lever Controls					5 ft. (1.5m)	10 ft. (3.0m)	15 ft. (4.6m)	20 ft. (6.1m)	25 ft. (7.6m)
			Up	Dn	Fd	Rv	**					
<b>Hoist Series K5</b>												
Standard Unit (Standard Control)	2	540119	1	1			526150	526151	526152	526164	529384	
Standard Unit (2 Hoist Control)	4	541565	2	2			526170	526171	526172	526175	526176	
Standard Unit with Hoistractor	4	539844	1	1	1	1	526170	526171	526172	526175	526176	
Standard Unit with Hoistractor (Free Wheel to Positive Drive)	5	539855	1	1	1	1	528220	528221	528222	542299	528223	
Standard Unit with Hoistractor (Positive Drive to Free Wheel)	5	540181	1	1	1	1	528220	528221	528222	542299	528223	
<b>Hoist Series K1</b>												
Standard Unit (Standard Control)	2	540119	1	1			526150	526151	526152	526164	529384	
Standard Unit (2 Hoist Control)	4	541565	2	2			526170	526171	526172	526175	526176	
Standard Unit with Hoistractor	4	539844	1	1	1	1	526170	526171	526172	526175	526176	
Standard Unit with Hoistractor (Free Wheel to Positive Drive)	5	539855	1	1	1	1	528220	528221	528222	542299	528223	
Standard Unit with Hoistractor (Positive Drive to Free Wheel)	5	540181	1	1	1	1	528220	528221	528222	542299	528223	
Combination Unit (Hoist/Hoistractor) with Bridge Crane Hoistractor	6	539860	1	1	2	2	539065	539066	539067		539458	
Combination Unit (Hoist/Hoistractor) with Bridge Crane Axial Piston Motor (A2, A6, A8, or B4 Series)	6	539858	1	1	2	2	522911	519306	519307	522928	522824	

\*\*Contact Application Specialist

NOTE: To order other hose lengths contact the factory.

NOTE: Hose lengths longer than 25 feet (7.6m) require Quick Exhaust Valves as part of the hose assembly for K5, K1, P1, P2 and TA.

NOTE: To order other hose lengths contact the factory. Hose lengths longer than 25 feet (7.6m) require Quick Exhaust Valves as part of the pendent control handles (539754 valve stem).

These handles are also used with hose lengths longer than 30 feet for K5, K1, P1, P2 and TA.

\*\*\*Axial Piston Motors require (2) Quick Exhaust Valves, contact factory.

### Rope Control Assembly

Rope Control assembly includes two (2) ropes, two (2) handles and one (1) connecting bar.

Part Number	Description
A108886	Rope Control Assembly 6 ft. Length.
A108886-10	Rope Control Assembly 10 ft. Length.



### Chain (specify length required in feet when ordering)

Part Number	Chain Type	Link Chain	Roller Chain
<b>7 Series</b>			
532394	Link (Zinc Plated)		
<b>K5 Series</b>			
522893	Link		
536462	Link (Zinc Plated)		
10356	Roller		
<b>K1 Series</b>			
513131	Link (Zinc Plated)		
542040	Standard Link		
<b>P1 Series</b>			
20676	Link		
31445	Link (Zinc Plated)		
10356	Roller		
17265	Spark Resistant Roller (Stainless)		
<b>P2 Series</b>			
20592	Link		
29962	Link (Zinc Plated)		
541397	Spark Resistant Link (Stainless)		
11532	Roller		
17266	Spark Resistant Roller (Stainless)		
<b>P3 Series</b>			
513131	Link (Zinc Plated)		
507245	Link (Zinc Plated Low Headroom)		
542040	Standard Link		

## Pendent Control Handles and Hose Assemblies

Hoist Configuration	Pendent Control Handles						Pendent Control Hose Assemblies				
	No. of Levers	Part No.	Lever Controls				5 ft. (1.5m)	10 ft. (3.0m)	15 ft. (4.6m)	20 ft. (6.1m)	25 ft. (7.6m)
			Up	Dn	Fd	Rv					
<b>Hoist Series P1</b>											
Standard Unit (Standard Control)	2	540119	1	1			526150	526151	526152	526164	529384
Standard Unit (2 Hoist Control)	4	541565	2	2			526170	526171	526172	526175	526176
Standard Unit with Hoistractor	4	539844	1	1	1	1	526170	526171	526172	526175	526176
Standard Unit with Hoistractor (Free Wheel to Positive Drive)	5	539855	1	1	1	1	528220	528221	528222	542299	528223
Standard Unit with Hoistractor (Positive Drive to Free Wheel)	5	540181	1	1	1	1	528220	528221	528222	542299	528223
<b>Hoist Series P2</b>											
Standard Unit (Standard Control)	2	540119	1	1			526150	526151	526152	526164	529384
Standard Unit (2 Hoist Control)	4	541565	2	2			526170	526171	526172	526175	526176
Standard Unit with Hoistractor	4	539844	1	1	1	1	526170	526171	526172	526175	526176
Standard Unit with Hoistractor (Free Wheel to Positive Drive)	5	539855	1	1	1	1	528220	528221	528222	542299	528223
Standard Unit with Hoistractor (Positive Drive to Free Wheel)	5	540181	1	1	1	1	528220	528221	528222	542299	528223
Combination Unit (Hoist/Hoistractor) with Bridge Crane Hoistractor	6	539860	1	1	2	2	539065	539066	539067		539458
Combination Unit (Hoist/Hoistractor) with Bridge Crane Axial Piston Motor (A2, A6, A8, or B4 Series)***	6	539858	1	1	2	2	522911	519306	519307	522928	522824
<b>Hoist Series P3</b>											
Standard Unit (Standard Control)	2	540117			1	1	513549	513550	513551	516696	523360
Standard Unit with Hoistractor	4	539856	1	1	1	1	522911	519306	519307	522948	522824
Combination Unit (Hoist/Hoistractor)	4	539856	1	1	1	1	522911	519306	519307	522948	522824
Low Headroom	4	539856	1	1	1	1	518504	518505	518506	518575	539788
<b>Hoist Series TA</b>											
Standard Unit	2	540120			1	1	526150	526151	526152	526164	529384
Standard Unit (Free Wheel to Positive Drive with coast down)	2	539854			1	1	526150	526151	5261521	526164	529384
Standard Unit (Free Wheel to Positive Drive)	3	539854			1	1	531111	531112	531113	531114	542266
Standard Unit (Positive Drive to Free Wheel)	3	539847			1	1	531111	531112	531113	531114	542266
Standard Unit with Existing Hoist (K5, K1, P1, or P2)	4	539844	1	1	1	1	526170	526171	526172	526175	526176
Standard Unit with Existing Hoist (K5, K1, P1, or P2); (Free Wheel to Positive Drive with coast down)	4	539844	1	1	1	1	526170	526171	526172	526175	526176
Standard Unit with Existing Hoist (P3)	4	539856	1	1	1	1	522911	519306	519307	522948	522824
Standard Unit (Positive Drive to Free Wheel) with Existing Hoist (K5, K1, P1, or P2)	5	540181	1	1	1	1	528220	528221	528222	542299	528223
Standard Unit (Free Wheel to Positive Drive) with Existing Hoist (K5, K1, P1, or P2)	5	539855	1	1	1	1	528220	528221	528222	542299	528223
<b>Axial Piston Motor</b>											
A2 Motor*	2	506151			1	1	506136	506138	506140		
B4 Motor*	2	506152			1	1	506136	506138	506140		
A6 Motor*	2	506153			1	1	506496	506498	506500		
A8 Motor*	2	506154			1	1	506496	506498	506500		
A2 Motor with Hoist*	4	506147	1	1	1	1	513549	513550	513551		
B4 Motor with Hoist*	4	506148	1	1	1	1	513549	513550	513551		
A6 Motor with Hoist*	4	506149	1	1	1	1	513549	513550	513551		
A8 Motor with Hoist*	4	506148	1	1	1	1	513549	513550	513551		

\*Includes (2) quick exhaust valves and all necessary fittings.

\*\*Contact Application Specialist

NOTE: To order other hose lengths contact the factory. Hose lengths longer than 25 feet (7.6m) require Quick Exhaust Valves as part of the pendent control handles (539754 valve stem).

These handles are also used with hose lengths longer than 30 feet for K5, K1, P1, P2 and TA.

\*\*\*Axial Piston Motors require (2) Quick Exhaust Valves, contact factory.



# The Total Solution

The total solution from Cooper Tools includes not only a complete line of quality industrial tools and accessories but also a professional engineering and product support staff to help customize each tool to specific application requirements. All are as close as a telephone or e-mail.

Cooper Tools maintains company-owned Service Centers in strategic locations throughout the world, staffed with professional tool repair technicians who use genuine Cooper Tools parts and who are outfitted with the very latest in testing, calibration



and inspection equipment. Each tool that is returned to a customer from one of our Service Centers carries with it a warranty that is Cooper Tools' assurance that it will perform just like it did when it was purchased new.

Our support personnel are fully capable of helping to diagnose problems and promptly recommend solutions.

Our complete line of tools are carefully designed and

built from the finest materials available in order to provide years of trouble free service. But, as with any piece of equipment, service problems can occur. All tools are designed to be easy to service ... that is, of course, with properly trained personnel.

To facilitate quick repairs, and limit downtime ...

## TRAINING

Cooper Tools conducts training seminars covering all aspects of every tool we make.

Introductory training seminars are designed to fully acquaint students with the entire line of tools and their fundamental operation. Advanced training seminars, which are often tailored to individual needs, are designed to hone the skills of the experienced student. Hands-on experience, with an emphasis on troubleshooting and repairing, are the focus of this training.

Service literature, product information, brand catalogs and FAQs are also available around the clock on the web. Just access [www.coopertools.com](http://www.coopertools.com) for the latest information available.







# Sales & Service Centers

**Note:** All locations may not service all products. Please contact the nearest Sales & Service Center for the appropriate facility to handle your service requirements.

## Dallas, TX

**Cooper Tools  
Sales & Service Center**  
1470 Post & Paddock  
Grand Prairie, TX 75050  
Tel: (972) 641-9563  
Fax: (972) 641-9674

## Detroit, MI

**Cooper Tools  
Sales & Service Center**  
2630 Superior Ct.  
Auburn Hills, MI 48326  
Tel: (248) 391-3700  
Fax: (248) 391-7824

## Houston, TX

**Cooper Tools  
Sales & Service Center**  
6550 West Sam Houston  
Parkway North, Suite 200  
Houston, TX 77041  
Tel: (713) 849-2364  
Fax: (713) 849-2047

## Seattle, WA

**Cooper Tools  
Sales & Service Center**  
2865 152nd Ave N.E.  
Redmond, WA 98052  
Tel: (425) 497-0476  
Fax: (425) 497-0496

## Lexington, SC

**Cooper Tools**  
670 Industrial Drive  
Lexington, SC 29072  
Tel: (800) 845-5629  
Tel: (803) 951-7544  
Fax: (803) 358-7681

## Los Angeles, CA

**Cooper Tools  
Sales & Service Center**  
15503 Blackburn Ave  
Norwalk, CA 90650  
Tel: (562) 926-0810  
Fax: (562) 802-1718

## York, PA

**Cooper Tools  
Sales & Service Center**  
York Service Center  
3990 E. Market Street  
York, PA 17402  
Tel: (717) 755-2933  
Fax: (717) 757-1659

## Brazil

**Cooper Tools Industrial Ltda.**  
Av. Liberdade, 4055  
Zona Industrial - Iporanga  
18087-170 Sorocaba, SP Brazil  
Tel: (011) 55 15 238 3929  
Fax: (011) 55 15 228 3260

## Canada

**Cooper Tools  
Sales & Service Center**  
5925 McLaughlin Road  
Mississauga, Ont. L5R 1B8  
Canada  
Tel: (905) 501-4785  
Fax: (905) 501-4786

## China

**Cooper (China) Co., Ltd.**  
955 Sheng Li Road,  
Heqing Pudong, Shanghai  
China 201201  
Tel: +86-21-28994176  
Fax: + 86-21-51118446

## France

**Cooper Power Tools SAS  
Recoules Operation**  
Zone Industrielle  
BP 28  
Avenue Maurice Chevalier  
77831 Ozoir-la-Ferrière Cedex  
France  
Tel: (011) 33 1 64 43 22 00  
Fax: (011) 33 1 64 40 17 17

## Germany

**Cooper Power Tools  
GmbH & Co. OHG**  
Postfach 30  
D-73461 Westhausen  
Tel: +49 (0) 73 63/ 81-0  
Fax: +49 (0) 73 63/ 81-222

## Mexico

**Cooper Power Tools  
de México S.A. de C.V.**  
Libramiento La Joya No. 1  
Bodega No. 2  
Esq. Politécnico, Barrio San José  
Cuautitlán, Edo de México C.P. 54870  
Phone: (011) 525 5899 9510  
Fax: (011) 525 5870 5012



## Cooper Tools Is On The Web!

Cooper Tools provides a complete resource for power tools on-line. Our website [www.coopertools.com](http://www.coopertools.com) offers product information, service literature, brand catalogs, press releases and more. A dominant source of information, the Cooper Tools website is your source for application solutions on-line.



## Making your job easier is our goal!

You can access service literature anytime. Choose a category such as Assembly Tools or Material Removal Tools from the main menu and then click on the brand you're looking for. You'll be on your way to any current service literature you need, whether it's Cleco, Apex, Master Power, or any of our power tool brands.

Up-to-date product catalogs are also available online providing

you with current information on our broad product line. Even Material Safety Data Sheets (M.S.D.S.) for Safety and Disposal Information are available on our website.



## It's simple!

Our *Customer Care* section provides you with information such as answers to frequently asked questions or contact phone numbers and addresses for your area of the country. You can browse through the *What's New* information to learn how Cooper Tools continues to be your source for solutions.

For even faster searches, you can go direct to a brand site by simply entering the brand name. Entering [www.dotco-tools.com](http://www.dotco-tools.com) takes you directly to the Dotco brand site.



What is the future of [www.coopertools.com](http://www.coopertools.com)? A dynamic site continuing to focus on your need for up-to-date information on the latest Cooper Tools' offerings that you can access anytime you need...twenty-four hours a day, seven days a week!

## ***One of the broadest range of tools in the world is at your fingertips!***

Cooper Tools covers a wide range of industrial markets, including aerospace, automotive, foundries, furniture, general industry, metal fabrication, petroleum, power generation, shipbuilding, and transportation. These markets have been served by Cooper Tools' brands for many decades, by offering our customers solutions and products that meet their demanding productivity requirements.

To receive a product catalog quickly, just go to [www.coopertoolscatalogs.com](http://www.coopertoolscatalogs.com). Select the literature or software you want. Then complete the "Contact Information" form, hit "Submit Request" and your order will be processed immediately. Materials normally arrive within 48 hours.



## ***Below are a few of our more popular product catalogs***



### **Apex Fastener Tools**

A comprehensive line of industrial quality bits, finders, sockets and extensions.  
(Catalog # TC-100)  
[www.apex-tools.com](http://www.apex-tools.com)



### **Dotco/Cleco Material Removal Tools**

A full line of pneumatic material removal tools including drills, sanders, and grinders.  
(Catalog # SP-102)  
[www.dotco-tools.com](http://www.dotco-tools.com)



### **Gardner-Denver Air Hoists**

A broad line of quality pneumatic hoists for industrial applications.  
(Catalog # SP-103)  
[www.gardnerdenvertools.com](http://www.gardnerdenvertools.com)



### **Apex Universal Joints**

Industrial quality universal joints that can be custom designed for most any application.  
(Catalog # SP-1400)  
[www.apexuniversal.com](http://www.apexuniversal.com)



### **Buckeye • Dotco • Gardner-Denver Power Motors**

A comprehensive line of industrial pneumatic motors for a multitude of applications.  
(Catalog # SP-104)  
[www.buckeye-tools.com](http://www.buckeye-tools.com)



### **Master Power Industrial Air Tools**

A complete line of industrial pneumatic tools for assembly and material removal applications.  
(Catalog # SP-904)  
[www.masterpowertools.com](http://www.masterpowertools.com)



### **Cleco Pneumatic Assembly Tools**

A full line of industrial pneumatic assembly tools from screwdrivers to nutrunners to impacts.  
(Catalog # SP-1000)  
[www.clecotools.com](http://www.clecotools.com)



### **Buckeye Fixtured Drills**

An extensive line of industrial pneumatic fixtured drills.  
(Catalog # SP-105)  
[www.buckeye-tools.com](http://www.buckeye-tools.com)



### **Utica Torque Products**

A full line of torque measuring products including torque screwdrivers, torque wrenches and analyzers.  
(Catalog # SP-301)  
[www.uticatools.com](http://www.uticatools.com)



### **Cleco D.C. Electric Assembly Tools**

A complete line of industrial D.C. electric assembly tools and controllers.  
(Catalog # SP-105)  
[www.clecotools.com](http://www.clecotools.com)



### **DGD Assembly Systems**

A complete line of spindles, D.C. electric assembly tools and controllers for the MVI.  
(Catalog # SP-703DE/EN)  
[www.coopertools.com](http://www.coopertools.com)



### **Airetool Tube Cleaners & Expanders**

A complete line of industrial tube cleaners, expanders and installation tools.  
(Catalog # SP-1100)  
[www.airetools.com](http://www.airetools.com)



## Sales & Service Centers

**Note:** All locations may not service all products. Please contact the nearest Sales & Service Center for the appropriate facility to handle your service requirements.

**Dallas, TX**  
**Cooper Tools**  
**Sales & Service Center**  
1470 Post & Paddock  
Grand Prairie, TX 75050  
Tel: (972) 641-9563  
Fax: (972) 641-9674

**Detroit, MI**  
**Cooper Tools**  
**Sales & Service Center**  
4121 North Atlantic Blvd.  
Auburn Hills, MI 48326  
Tel: (248) 391-3700  
Fax: (248) 391-6295

**Houston, TX**  
**Cooper Tools**  
**Sales & Service Center**  
6550 West Sam Houston  
Parkway North, Suite 200  
Houston, TX 77041  
Tel: (713) 849-2364  
Fax: (713) 849-2047

**Lexington, SC**  
**Cooper Tools**  
670 Industrial Drive  
Lexington, SC 29072  
Tel: (800) 845-5629  
Tel: (803) 359-1200  
Fax: (803) 358-7681

**Los Angeles, CA**  
**Cooper Tools**  
**Sales & Service Center**  
15503 Blackburn Ave  
Norwalk, CA 90650  
Tel: (562) 926-0810  
Fax: (562) 802-1718

**Seattle, WA**  
**Cooper Tools**  
**Sales & Service Center**  
2865 152nd Ave N.E.  
Redmond, WA 98052  
Tel: (425) 497-0476  
Fax: (425) 497-0496

**York, PA**  
**Cooper Tools**  
**Sales & Service Center**  
3990 East Market Street  
York, PA 17402  
Tel: (717) 755-2933  
Fax: (717) 757-1659

**Canada**  
**Cooper Tools**  
**Sales & Service Center**  
5925 McLaughlin Road  
Mississauga, Ont. L5R 1B8  
Canada  
Tel: (905) 501-4785  
Fax: (905) 501-4786

**Cooper Tools**  
P.O. Box 1410  
Lexington, SC 29071-1410  
USA  
Phone: 800-845-5629  
803-359-1200  
Fax: 803-359-0822

**Cooper Tools**  
2630 Superior Ct.  
Auburn Hills, MI 48326  
USA  
Phone: (248) 391-3700  
Fax: (248) 391-7824

**Cooper Tools**  
5925 McLaughlin Road  
Mississauga, Ontario  
Canada L5R 1B8  
Phone: (905) 501-4785  
Fax: (905) 501-4786

**Cooper Tools**  
**de México S.A. de C.V.**  
Libramiento La Joya No. 1  
Bodega No. 2  
Esq. Politécnico  
Barrio San José  
Cuautitlán, Edo de México  
C.P. 54870  
Phone: +52-55-5899-9510  
Fax: +52-55-5870-5012

**Cooper Tools Industrial Ltda.**  
Av. Liberdade, 4055  
Zona Industrial - Iporanga  
18087-170 Sorocaba, SP  
Brazil  
Tel: +55-15-3238-3929  
Fax: +55-15-228-3260

**Cooper Power Tools SAS**  
Zone industrielle – B.P. 28  
77831 Ozoir-la-Ferrière Cedex  
France  
Téléphone: +33-1-6443-2200  
Téléfax: +33-1-6440-1717

**Cooper Power Tools**  
**GmbH & Co. OHG**  
Postfach 30  
D-73461 Westhausen  
Germany  
Phone: +49 (0) 73 63/ 81-0  
Fax: +49 (0) 73 63/ 81-222  
HTWE.sales  
@cooperindustries.com

**Cooper Tools Hungária Kft.**  
Berkenyefa sor 7  
H-9027 Győr  
Hungary  
Tel: +36-96-505 300  
Fax: +36-96-505 301

**Cooper (China) Co., Ltd.**  
955 Sheng Li Road,  
Heqing Pudong, Shanghai  
China 201201  
Tel: +86-21-28994176  
+86-21-28994177  
Fax: + 86-21-51118446

[www.coopertools.com](http://www.coopertools.com)

**Cooper Industries, Ltd.**  
600 Travis, Ste. 5800  
Houston, TX 77002-1001  
P: 713-209-8400  
[www.cooperindustries.com](http://www.cooperindustries.com)