

SereneLife



SLPAC12

Portable Air Conditioner
Fan and Dehumidifier

USER MANUAL

CONTENT

I. Notes.....	3
II. Features and Components.....	4
III. Installation and Adjustment.....	6
IV. Control Setting.....	8
V. Drainage Instructions.....	11
VI. Maintenance.....	12
VII. Troubleshooting.....	14
VIII. Appendix.....	15

Please keep the manual for later review, and read the manual carefully before use.

I. Notes

Notes:

- The air conditioner is only suitable for indoor use, and is not suitable for other applications.
- Follow local grid interconnection rules while installing the air conditioner and ensure that it is properly grounded. If you have any question on electrical installation, follow the instructions of the manufacturer, and if necessary, ask a professional electrician to install it.
- Place the machine in a flat and dry place and keep a distance of above 50cm between the machine and the surrounding objects or walls.
- After the air conditioner is installed, ensure that the power plug is intact and firmly plugged into the power outlet, and place the power cord orderly to prevent someone from being tripped or pulling out the plug.
- Do not put any objects into the air inlet and outlet of the air conditioner. Keep the air inlet and outlet free from obstructions.
- When drainage hose is installed, ensure that it is properly connected, and is not blocked or bended.
- While adjusting the upper and lower wind-guide strips of the air outlet, pluck it with hands gently to avoid damaging wind-guide strips.
- When moving the machine, make sure that it is in an upright position.
- The machine should stay away from gasoline, flammable gas, stoves and other heat sources.
- Don't disassemble, overhaul and modify the machine arbitrarily, otherwise it will cause a machine malfunction or even bring harm to persons and properties. To avoid danger, if a machine failure occurs, ask the manufacturer or a professional to repair it.
- Do not install and use the air conditioner in the bathroom or other humid environments.
- Do not pull the plug to turn off the machine.
- Do not place cups or other objects on the unit to prevent water or other liquids from spilling into the air conditioner.

- Do not use insecticide sprays or other flammable substances near the air conditioner.
- Do not wipe or wash the air conditioner with chemical solvents such as gasoline and alcohol. When you need to clean the air conditioner, you must disconnect the power supply, and clean it with a half-wet soft cloth. If the machine is really dirty, scrub with a mild detergent.
- Children shall not play with the appliance. Cleaning and maintenance shall not be made by children without supervision.

II. Features and Components

1. Features

- New look, compact structure, streamlined machine, aristocratic atmosphere.
- Provides cooling, dehumidification and air supply function.
- Has automatic air swing function. The outlet can be covered when the machine is turned off to prevent dust from entering the unit.
- LED display control panel. The machine is beautiful and elegant. High-quality LED remote control is equipped to facilitate operation. The remote control can be placed on the back of the body. It adopts a user-friendly remote control storage design.
- Handles on both sides makes unit easy to move or relocate.
- Exhaust air vent is set high to facility assembly and keep the smooth flow of the exhaust hose.

2. Components

1. Mask
2. Top cover
3. Swing Leaf Air Vent
4. Rear Housing
5. Front Housing
6. Omni-directional wheel
7. Exhaust Hose Assembly
8. Window Sealing Plate Assembly
9. Remote Control
10. Rear Housing
11. EVA Filter Housing



- 12. Power COrd Hook
- 13. Handle
- 14. Air vent exhaust
- 15. Continuous Drainage hole
- 16. CON filter screen
- 17. Air Inlet Grille
- 18. Drainage hole
- 19. Power Cord
- 20. Power Cord Plug

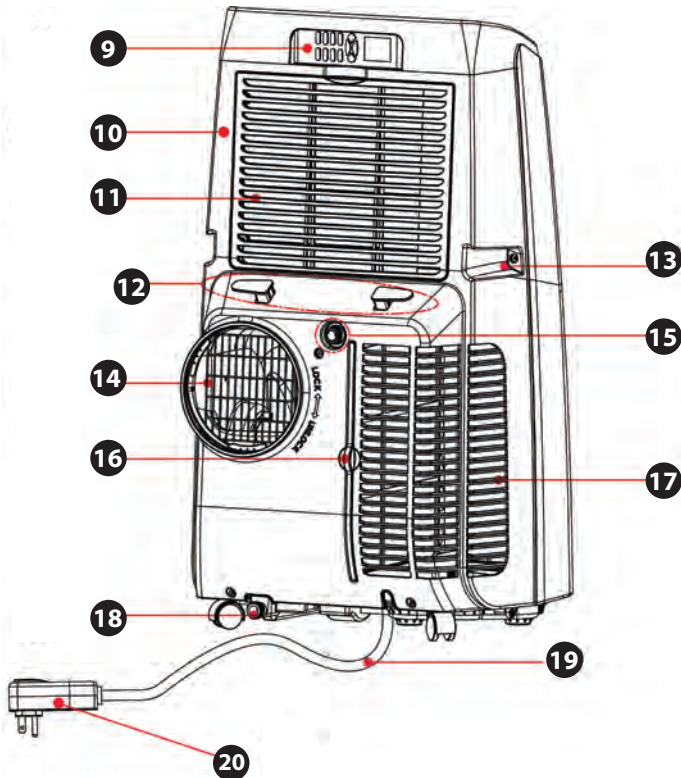
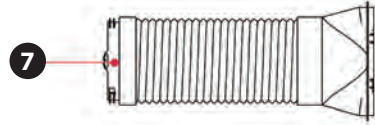

III. Installation and Adjustment

1. Installation:

Warning: before using the mobile air conditioner, keep it upright for at least two hours.

The air conditioner can be easily moved in the room. In the moving process, ensure that the air conditioner is in the upright position and should be placed on a flat surface.

Do not install and use the air conditioner in the bathroom or other humid environments.

1.1 Install the exhaust hose assembly (as shown in Figure 1):

Screw the hose assembly (exhaust fitting end) into the exhaust port on the rear panel (counterclockwise).

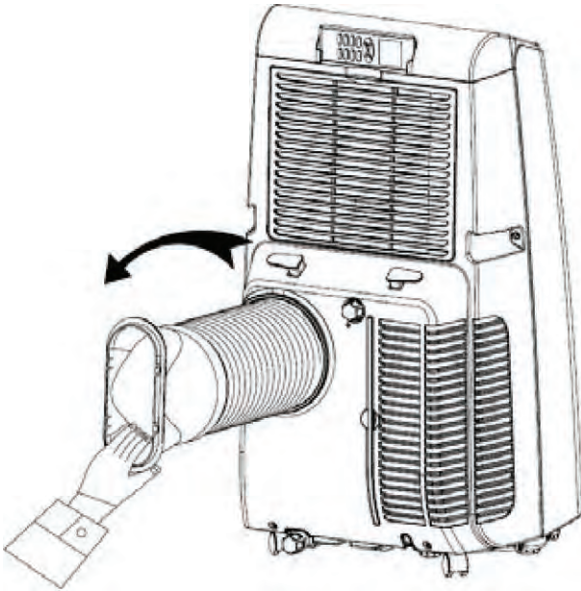

Figure 1

1.2 Install the window sealing plate assembly

1. Half open the window, and mount the window sealing plate assembly to the window (as shown in Figure 2 and Figure 3); the assembly can be placed in horizontal or vertical direction

- Slide open the window plate assembly. Adjust their opening distance to bring both ends of the assembly into contact with the window frame, and fix into place with screw.

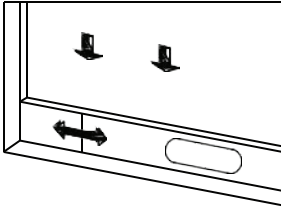

Figure 2

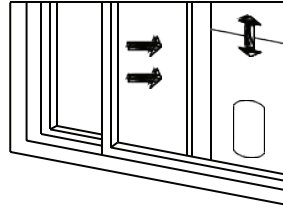

Figure 3

1.3 Install the unit

- Move the machine with installed heat hose and fittings near the window. The distance between the unit and walls or other objects shall be least 50cm (as shown in Figure 4)

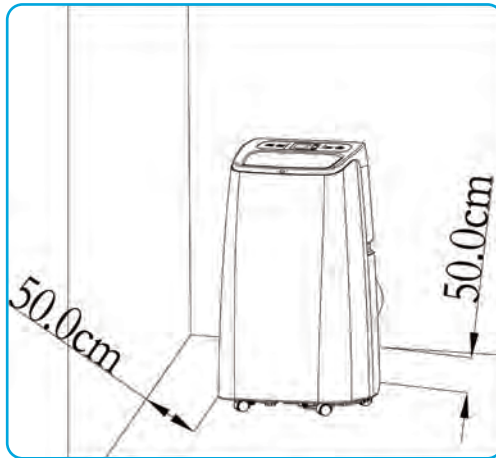

Figure 4

- Elongate the hose and snap the flat end of the hose joints into the elliptical hole of the window sealing plate assembly (as shown in Figure 5 and Figure 6) .

Notes:

- the flat end of the hose joints must be snapped into place.
- The hose cannot be distorted nor has substantial turning (greater than 45 °). Keep the ventilation of the hose unobstructed.

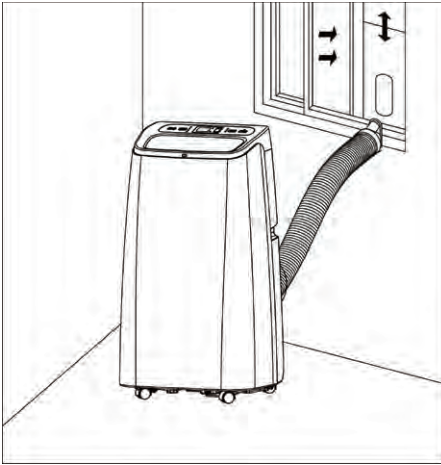

Figure 5



Figure 6

Important Notice

The length of the exhaust hose shall be 280~1,500mm, and this length is based on the specifications of the air conditioner. Do not use extension tubes or replace it with other different hoses, or this may cause a malfunction. Exhaust must be unobstructed; otherwise it may cause overheating.

IV. Control Setting

I. Operating Instructions

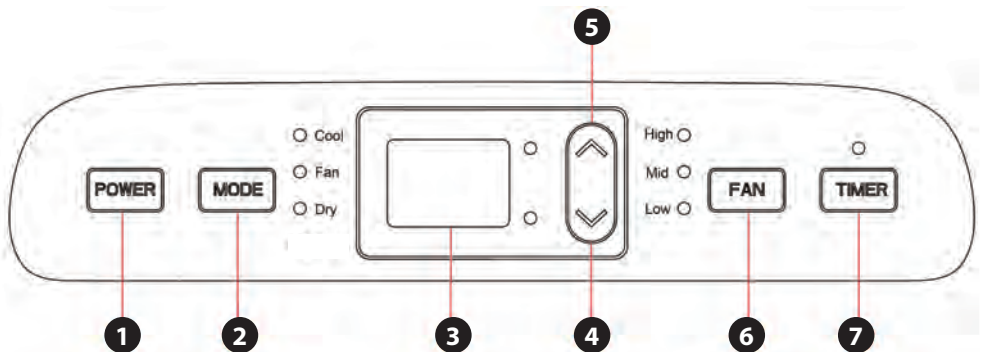

1. Power key
2. Mode selection key
3. Window display
4. Down key
5. Up key
6. Wind speed selection key
7. Timing key

When power is connected to the unit for the first time, buzzer will play power-on music, and then the machine will get into standby status.

- 1. Power Key:** Press the key to turn on and turn off the machine.
- 2. Mode Selection Key:** When power is on, press the key to switch between cooling → air supply → dehumidification → cooling → .mode.
- 3. Window display**
- 4.5. Up Key and Down Key:** Press the two keys to change the set temperature or timing the value, operate as follows:

While setting temperature, press UP key or DOWN key to select the required temperature (not available in air supply or dehumidification mode.) Simultaneously press both keys to switch between Celsius (°C) and Fahrenheit (°F).

6. Wind Speed Selection Key:

In cooling and air supply mode, press the key to select high, medium or low wind speed operation. In dehumidification mode, pressing the key is invalid and the fan will automatically choose low wind speed operation.

- 7. Timer Key:** During power ON, press the key to close timing.
During power off, press the key to open timing.

Press the key when timing symbol flashes, press up and down key to select required timing value.

Timing values can be set within 1-24 hours and the timing value is adjusted upwards or downwards by one hour increments.

II. Operating Instructions of the Remote Control

Instructions of key operation of the high-quality remote control are as follows:

- 1. Power:** Press the key to turn **ON** or turn **OFF** the machine.
- 2. Mode:** Press the key to switch between cooling, air supply, dehumidification.
- 3. Up:** Press the key to increase temperature and timing set value.
- 4. Down:** Press the key to reduce temperature and timing set value.
- 5. Fan:** Press the key to select high, medium and low wind speed.
- 6. Timer:** Press the key to set timing value.
- 7. Swing:** Press the key to turn on the air vent swing. Air flow of the air outlet can blow at different angles.
- 8. °C ↔ °F :** press the key to switch between Celsius and Fahrenheit.

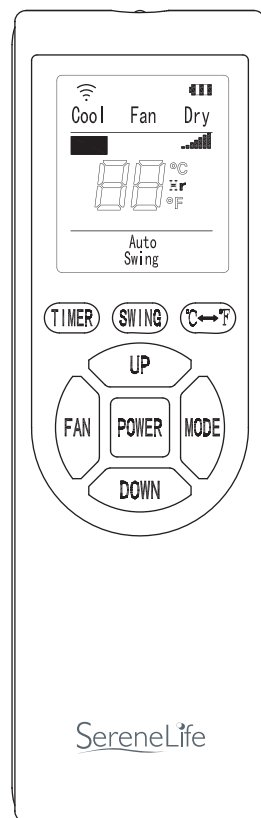

III. Protection Functions

3.1 Frost Protection Function:

In cooling, dehumidification or economic power saving mode, if the temperature of the exhaust hose is too low, the machine will automatically enter protection status; if the temperature of the exhaust hose rises to a certain temperature, it can automatically revert to normal operation.

3.2 Overflow Protection Function:

When water in the water pan exceeds level the warning level, the machine will automatically sound an alarm, and the LDC temperature display area will show "FL". At this point, you need to connect the drainage hose connecting the machine or the water outlet to drainage area to empty the water (details see Drainage Instructions at the end

of this chapter). After the water is emptied, the machine will automatically return to the original state.

3.3 Automatic Defrosting (cooling models have this function):

The machine has automatic defrosting function: during defrosting, heating symbol on the display screen will flash.

3.4. Protection Function of the Compressor

To increase the service life of the compressor, it has a 3-minute delay booting protection function after the unit is turned off and on again.

V. Drainage Instructions

1. Manual Drainage:

1. When the machine stops after the water is full, turn off the machine power and unplug the power plug.

Notes: Please move the machine carefully, so as not to spill the water in the water pan at the bottom of the body.

2. Place the water container below the side water outlet behind the unit.

3. Unscrew the drainage cover and unplug the water plug, the water will automatically flow out the water container.

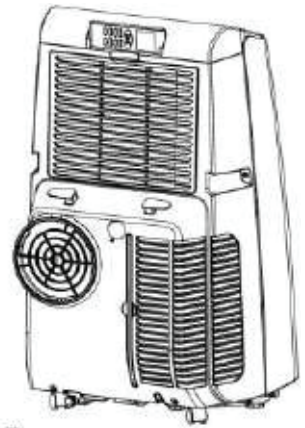

Figure 1

Notes:

1. Keep the drainage cover and the water plug properly set.

2. During drainage, the body can be tilted slightly backwards.

3. If your water container cannot hold all the water, before the water container is full, stuff the water outlet with the water plug as soon as possible to prevent water from flowing to the floor or the carpet.

4. When the water is discharged, re-insert the water plug, and tighten the drainage cover.

Notes:

1. Restart the machine after the water plug and drainage cover are installed, otherwise condensate water of the machine will flow to the floor or the carpet.

2. Continuous drainage (only applicable to cooling and dehumidification mode), as shown in figure 2:

1. Unscrew the drainage cover, and unplug the water plug.
2. Set the drainage hose into the water outlet.
3. Connect the drainage hose to the bucket.



Figure 2

VI. Maintenance

Cleaning:

Before cleaning and maintenance, turn off the machine and unplug.

1. Clean the surface

Clean the surface of the machine with a wet soft cloth. DO NOT use chemicals such as benzene, alcohol, gasoline etc; otherwise the surface of the aircondition or the whole machine might get damaged.

2. Clean the filter screen

If the filter screen is clogged with dust and the effectiveness of the air conditioning is reduced, be sure to clean the screen every two weeks.

1. Retaining screw
2. Filter holder
3. Filter holder

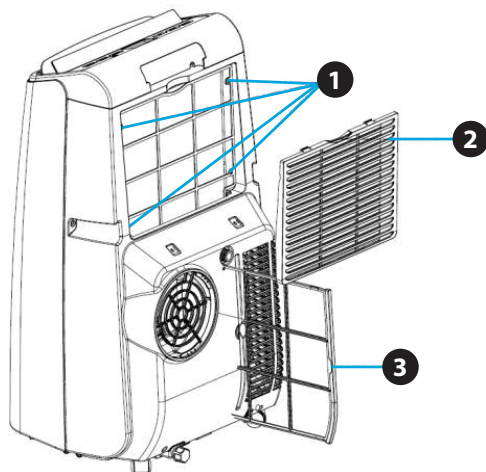
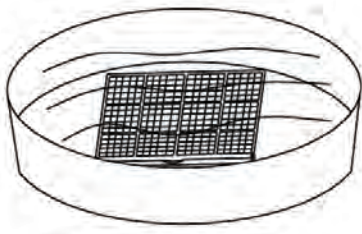

2.1 Clean the upper filter screen frame

1. Clasp the wedging block of the EVA filter screen frame with hands. Force down from the outside to remove the EVA filter screen frame. Unscrew 4 screws fixing the EVA filter screen and rear housing to remove the EVA filter screen (as image shown)
2. With vacuum cleaner, vacuum off all lint, and dander trapped on filter.
3. Put the EVA filter screen into warm water with neutral detergent (about 40°C/104°F) and dry it in the shade after rinsing clean.

2.2: Clean the lower filter screen frame

1. Hold the handle of the CON filter screen frame, and pull it outward gently to remove it
2. Follow cleaning instructions listed on 2.1.2 above.

Postseason Storage

1. Unscrew the drainage cover, unplug the water plug, and discharge the water in the internal water pan into other water containers or directly tilt the body to discharge the water into other containers.
2. Turn on the machine, adjust it to low-wind ventilation mode, and maintain this state until the drainage hose becomes dry, so as to keep the inside of the body in a dry state and prevent it from mildewing.
3. Turn off the machine, unplug the power plug, and wrap the power cord around the wrapping post; install the water plug and the drainage cover.
4. Remove the exhaust hose and keep it in safe place.
5. Cover the air conditioner with a plastic bag. Put the air conditioner in a dry place, keep it out of the reach of children, and take dust control measures. Ideally, store in original box.
6. Remove batteries of the remote control to prevent acid damage.

Note: Ensure that the unit is placed in a dry place and keep all machine components properly stored.

VII. Troubleshooting

Do not repair or disassemble the air conditioner by yourself. Unqualified repair will void the warranty, and may cause damage to users or their properties.

Problems	Reasons	Solutions
The conditioner does not work	There is no electricity	Turn it on after connecting it to a socket with electricity. Reset circuit breaker on the power cord
	The overflow indicator displays "FL"	Discharge the water inside.
	The ambient temperature is too low or too high?	Recommend to use the machine in at the temperature of 7-35 °C (44-95 °F).
	In cooling mode, the room temperature is lower than the set temperature.	Change the set temperature
	In dehumidification mode, the ambient temperature is low.	The machine is placed in a room with an ambient temperature of greater than 17 °C (62 °F).
The cooling effect is not good	There is direct sunlight	Pull the Curtain.
	Doors or windows are open; there are a lot of people; or in cooling mode, there are other sources of heat	Close doors and windows, and add new air conditioner
	The filter screen is dirty	Clean or replace the filter screen
	The air inlet or outlet is blocked	Clear obstructions
Big Noise	The air conditioner is not placed on a flat surface	Put the air conditioner on a flat and hard place (to reduce noise)
The compressor does not work.	Overheat protection starts	Wait for 3 minutes until the temperature is lowered, and then restart the machine
The remote control does not work.	The distance between the machine and the remote control is too far.	Let the remote control get close to the air conditioner, and make sure that the remote control directly faces to the direction of the remote control receiver.
	The remote control is not aligned with the direction of the remote control receiver.	
	Batteries are dead	Replace batteries
Displays 'E1'.	The hose temperature sensor is abnormal.	Check the hose temperature sensor and related circuitry.
Displays 'E2'	The room temperature sensor is abnormal.	Check the room temperature sensor and related circuitry.

If problems not listed in the table occur or recommended solutions do not work, please contact the professional service organization.

Intelligent Detection Function

Code	Meaning
E1	The hose temperature sensor is abnormal
E2	The room temperature sensor is abnormal
E4	Anti-freeze protection
FL	Full water

VIII. Appendix

Fuse Parameters

Type: FSD or 50F

Voltage: 250V

Current: 3.15A

Schematic Diagram

1	Condenser
2	Capillary
3	Compressor
4	Evaporator

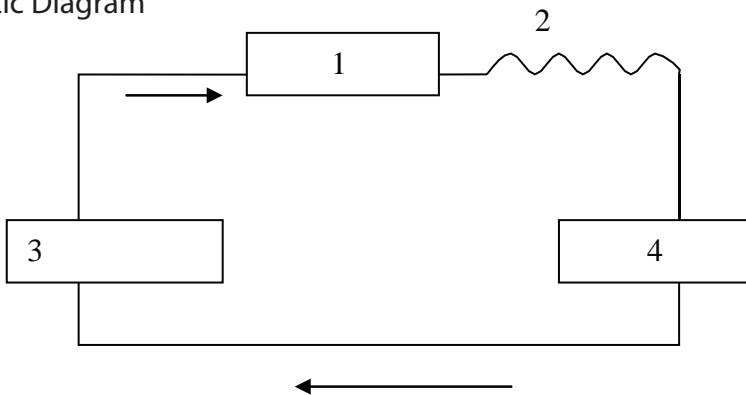

For model, technology and specific parameters please refer to product nameplate



Treatment: Don't put the abandoned machine with other unsorted waste together. Such waste shall be placed separately for other special use.

SereneLife



VISIT US ONLINE:

Have a question?

Need service or repair?

Want to leave a comment?

PyleUSA.com/ContactUs

PYLE