

*Potential Failure Mode
and Effects Analysis*

FMEA
Fourth Edition



POTENTIAL FAILURE MODE AND EFFECTS ANALYSIS (FMEA)

Reference Manual
Fourth Edition

First Edition, February 1993 • Second Edition, February 1995 • Third Edition, July 2001,
Fourth Edition, June 2008

Copyright © 1993, © 1995, © 2001, © 2008

Chrysler LLC, Ford Motor Company, General Motors Corporation

ISBN: 978-1-60534-136-1

FOREWORD

4th Edition

The FMEA 4th Edition is a reference manual to be used by suppliers to Chrysler LLC, Ford Motor Company, and General Motors Corporation as a guide to assist them in the development of both Design and Process FMEAs. The manual does not define requirements; it is intended to clarify questions concerning the technical development of FMEAs. This manual is aligned with SAE J1739.

Summary of Changes in the 4th edition FMEA Reference Manual

The DFMEA and PFMEA methods described in the 4th edition FMEA Reference Manual include those associated with design at the system, subsystem, interface, and component level and the process at manufacturing and assembly operations.

General Changes

- The formatting used in the 4th edition is intended to provide easier reading.
 - An index is included.
 - Icons are used to indicate key paragraphs and visual cues are used.
- Additional examples and verbiage have been provided to improve the utility of the manual and to provide a closer tie into the FMEA process as it develops.
- Reinforcement of the need for management support, interest, and review of the FMEA process and results.
- Define and strengthen the understanding of the linkage between DFMEA and PFMEA as well as defining the linkages to other tools.
- Improvements to the Severity, Occurrence, Detection ranking tables so that they are more meaningful to real world analysis and usage.
- Alternative methods are introduced that are currently being applied in industry.
 - Additional appendices which have example forms and special case application of FMEA.
 - The focus on the “standard form” has been replaced with several options that represent the current application of FMEA in industry.
- The suggestion that RPN not be used as the primary means for assessing risk. The need for improvement has been revised including an additional method, and the use of thresholds on RPN is clarified as a practice that is not recommended.

Chapter I provides general FMEA guidelines, the need for management support and having a defined process for developing and maintaining FMEAs, and the need for continuous improvement.

Chapter II describes the general application of the FMEA methodology, which is common between DFMEA and PFMEA processes. This includes the planning, strategy, action plans, and the need for management support and responsibility in FMEAs.

Chapter III focuses on DFMEA (Design Failure Mode Effects and Analysis), establishing the scope of the analysis, use of block diagrams, various types of DFMEAs, formation of the teams, basic procedure for analysis, action plans, and follow-up, alternatives to RPN, and connection to PFMEAs and validation plans.

Chapter IV focuses on PFMEA (Process Failure Mode Effects and Analysis), establishing the scope of the analysis, use of flow diagrams, formation of teams, basic procedure for analysis, action plans, the connection to DFMEAs and the development of control plans.

The **Appendices** have several examples of forms for DMFEA and PFMEA and addresses different applications and procedures for addressing design and process risk.

The Supplier Quality Requirements Task Force would like to thank the following individuals, and their companies, who have contributed their time and efforts to the development of this edition of the FMEA Reference Manual:

Michael Down, General Motors Corporation
Lawrence Brozowski, General Motors Corporation
Hisham Younis, Ford Motor Company
David Benedict, Chrysler LLC
John Feghali, Chrysler LLC
Michael Schubert, Delphi
Rhonda Brender, Delphi
Gregory Gruska, Omnex
Glen Vallance, Control Planning Initiatives
Milena Krasich, Bose
William Haughey, ReliaTrain

This manual is a copyright of Chrysler LLC, Ford Motor Company and General Motors Corporation, with all rights reserved. Additional copies may be obtained from AIAG @ www.aiag.org. Supply chain organizations of Chrysler LLC, Ford Motor Company or General Motors Corporation have permission to copy forms used in this manual.

TABLE OF CONTENTS

General Changes.....	i
Chapter I.....	1
General FMEA Guidelines.....	1
Introduction.....	2
FMEA Process.....	2
Purpose of Manual.....	3
Scope of Manual.....	4
Impact on Organization and Management.....	4
FMEA Explained.....	5
Follow-up and Continuous Improvement.....	6
Chapter II.....	7
Overview of FMEA Strategy, Planning and Implementation.....	7
Introduction.....	8
Basic Structure.....	8
Approach.....	8
Identify the Team.....	9
Define the Scope.....	10
Define the Customer.....	11
Identify Functions, Requirements, and Specifications.....	11
Identify Potential Failure Modes.....	12
Identify Potential Effects.....	12
Identify Potential Causes.....	12
Identify Controls.....	13
Identifying and Assessing Risk.....	13
Recommended Actions and Results.....	13
Management Responsibility.....	14
Chapter III.....	15
DFMEA Design Failure Mode and Effects Analysis.....	15
Introduction.....	16
Customer Defined.....	16
Team Approach.....	17
Manufacturing, Assembly and Serviceability Considerations.....	17
Development of a Design FMEA.....	18
Prerequisites.....	18
Block (Boundary) Diagrams.....	18
Parameter (P) Diagrams.....	21
Functional Requirements.....	22
Other Tools and Information Resources.....	22
Example DFMEA.....	25
Header of the Design FMEA Form (fields A-H).....	25
Body of the DFMEA Form (fields a – n).....	29
Maintaining DFMEAs.....	64
Leveraging DFMEAs.....	65
Linkages.....	65
Design Verification Plan & Report (DVP&R).....	66
PFMEA.....	66
Chapter IV.....	67
PFMEA Process Failure Mode and Effects Analysis.....	67
Introduction.....	68
Customer Defined.....	69
Team Approach.....	69
Design Considerations.....	69
Development of a Process FMEA.....	70

Prerequisites	70
Process Flow Diagram and linkage to PFMEA	70
Other Tools and Information Sources	73
Research Information	73
Example PFMEA Form	75
Header of the Process FMEA Form (fields A-H)	75
Body of the PFMEA Form (fields a – n)	77
Maintaining PFMEAs	110
Leveraging PFMEAs	110
Linkages	111
To DFMEA	111
To Control Plan	112
APPENDICES	113
Appendix A: Sample Forms	114
DFMEA Forms	114
PFMEA Forms	121
Appendix B: System Level FMEA	130
Interfaces	131
Interactions	131
Relationships	133
Multiple Levels of Design FMEAs	133
Appendix C: Alternative Risk Assessments	135
Alternatives to RPN	135
Alternative: SO (S x O)	136
Alternative: SOD, SD	136
Appendix D: Alternative Analyses Techniques	137
Failure Mode, Effect and Criticality Analysis (FMECA)	137
Design Review Based on Failure Modes (DRBFM)	137
Fault Tree Analysis (FTA)	137
References and Suggested Readings	140
Index	141

TABLES and FIGURES

Figure III.1a Block (Boundary) Diagram Examples	19
Figures III.1b, c Block (Boundary) Diagram Examples	20
Figure III.2 Example of a Parameter (P) Diagram for a Generic Catalytic Converter	21
Table III.1 Sample DFMEA Form with Minimal Information Elements & Example Entries.....	24
Table III.3 Example Potential Failure Modes.....	32
Table III.4 Example Potential Effects	35
Table Cr1 Suggested DFMEA Severity Evaluation Criteria	37
Table III.5 Example Potential Causes	42
Table Cr2 Suggested DFMEA Occurrence Evaluation Criteria.....	46
Table III.6 Examples of Prevention and Detection Design Controls.....	51
Table Cr3 Suggested DFMEA/PFMEA Prevention/Detection Evaluation Criteria	54
Table III.7 Examples of Causes, Controls and Recommended Actions	64
Figure III.7 DFMEA Information Interrelationships Flow	65
Figure IV.1 High Level to Detailed Process Maps	71
Figure IV.2 Example Process Flow Diagram	72
Table IV.1 Sample PFMEA Form with Minimal Information Elements & Example Entries	74
Table IV.2 Example of Process Step/Function/Requirements Columns on PFMEA Form including Potential Failure Modes.....	81
Table IV.3 Example of Effects.....	85
Table Cr1 Suggested PFMEA Severity Evaluation Criteria.....	88
Table Cr2 Suggested PFMEA Occurrence Evaluation Criteria.....	93
Table IV.4 Examples of Causes and Controls	96
Table Cr3 Suggested Process FMEA Detection Evaluation Criteria.....	100
Table IV.5 Examples of Causes, Controls and Actions.....	110
Figure IV.5 PFMEA Information Interrelationship Flow.....	111
DFMEA Form A	115
DFMEA Form B.....	116
DFMEA Form C.....	117
DFMEA Form D	118
DFMEA Form E.....	119
DFMEA Form F	120
PFMEA Form A	122
PFMEA Form B	123
PFMEA Form C	124
PFMEA Form D.....	125
PFMEA Form E.....	126
PFMEA Form F.....	127
PFMEA Form G	128
PFMEA Form H	129
Figure B.1 Interfaces and Interactions.....	130
Figure B.2 Item, Functions, and Failure.....	132
Figure B.3 DFMEA Effects Linkages	134
Table C.1 Contrast among RPN, SOD and SD.....	136
Figure D.1 Example of DRBFM Elements.....	138
Figure D.2 FTA Tree Structure	139

Chapter I

General FMEA Guidelines

Introduction

This manual introduces the topic of Potential Failure Mode and Effects Analysis (FMEA) and gives general guidance in the application of the technique.

FMEA Process

FMEA is an analytical methodology used to ensure that potential problems have been considered and addressed throughout the product and process development process (APQP – Advanced Product Quality Planning). Its most visible result is the documentation of the collective knowledge of cross-functional teams.

Part of the evaluation and analysis is the assessment of risk. The important point is that a discussion is conducted regarding the design (product or process), review of the functions and any changes in application, and the resulting risk of potential failure.

Each FMEA should ensure that attention is given to every component within the product or assembly. Critical and safety related components or processes should be given a higher priority.

One of the most important factors for the successful implementation of an FMEA program is timeliness. It is meant to be a “before-the-event” action, not an “after-the-fact” exercise. To achieve the greatest value, the FMEA must be done before the implementation of a product or process in which the failure mode potential exists. Up-front time spent properly completing an FMEA, when product/process changes can be most easily and inexpensively implemented, will minimize late change crises. Actions resulting from an FMEA can reduce or eliminate the chance of implementing a change that would create an even larger concern.

Ideally, the Design FMEA process should be initiated in the early stages of the design and the Process FMEA before tooling or manufacturing equipment is developed and purchased. The FMEA evolves throughout each stage of the design and manufacturing development process and may also be used in problem solving.

FMEA can also be applied to non-manufacturing areas. For example, FMEA could be used to analyze risk in an administration process or the evaluation of a safety system. In general, FMEA is applied to potential failures in product design and manufacturing processes where the benefits are clear and potentially significant.

Purpose of Manual

This manual describes the basic principles and implementation of the FMEA¹ process and how it is integrated within the product and process development cycle. This includes the documentation of this process and how the analyses can be applied for timely necessary improvement of a product or a process in its early and full development stage.

This manual also provides descriptions and examples of alternate and supporting methodologies for these analyses, their specific advantages and limitations, guidance of how the analysis is to be carried out for the maximum reliability improvement or mitigation of potential safety risks. The manual provides guidance on how the risk can be represented, measured and prioritized for cost effective mitigation of the failure effects.

As a tool in risk evaluation, FMEA is considered to be a method to identify severity of potential effects of failure and to provide an input to mitigating measures to reduce risk. In many applications, FMEA also includes an estimation of the probability of occurrence of the causes of failure and their resultant failure modes. This broadens the analysis by providing a measure of the failure mode's likelihood. To minimize risk, the likelihood of failure occurrence is reduced which increases product or process reliability. FMEA is a tool that is instrumental in reliability improvement.

There are three basic cases for which FMEA process is to be applied, each with a different scope or focus:

- | | |
|---------|---|
| Case 1: | New designs, new technology, or new process.

The scope of the FMEA is the complete design, technology, or process. |
| Case 2: | Modifications to existing design or process.

The scope of the FMEA should focus on the modification to design or process, possible interactions due to the modification, and field history. This can include changes in regulatory requirements. |
| Case 3: | Use of an existing design or process in a new environment, location, application, or usage profile (including duty cycle, regulatory requirements, etc.).

The scope of the FMEA should focus on the impact of the new environment, location, or application usage on the existing design or process. |

¹ The FMEA present herein also is known as a Failure Modes Effects and Criticality Analysis (FMECA) since it includes a quantification of the risks.

Scope of Manual

The analytical methods presented in this manual are applicable to any product or process. However, this manual will focus on those applications prevalent within the automotive industry and its suppliers.

Impact on Organization and Management

FMEA is an important activity within any company. Because the development of an FMEA is a multi-disciplined activity affecting the entire product realization process, its implementation needs to be well planned to be fully effective. This process can take considerable time and a commitment of the required resources is vital. Important to FMEA development is a process owner and senior management commitment.

Implementation approach will vary depending on the size and structure of the company concerned, although the principles will be the same:

- The scope will cover FMEAs produced in house and by multi-tier suppliers.
- Address Design and Process FMEAs, as applicable.
- Accomplish this by having the FMEA process an integral part of the APQP process.
- Part of engineering technical reviews.
- Part of the regular sign-off and approval of the product or process design.

An FMEA is developed by a multi-functional (or cross-functional) team. The team size will depend both on the complexity of the design and the size and organization of the company. Team members need relevant expertise, available time and authority sanctioned by management.

A comprehensive training program should be implemented including:

- Management Overview
- Training for users
- Supplier Training
- Facilitator Training

Ultimately, management has the responsibility and ownership for development and maintenance of the FMEAs.

FMEA Explained

FMEAs are an integral part of managing risk and supporting continual improvement. Consequently, FMEA becomes a key part of Product and Process development. The Advanced Product Quality Planning (APQP) process identifies five general areas of focus in this development process:

- Plan and Define Program
- Product Design and Development
- Process Design and Development
- Product and Process Validation
- Feedback, Assessment and Corrective Action

The APQP Reference manual shows DFMEAs as an activity in the Product Design and Development section of the timing chart and PFMEAs in the Process Planning and Development section. The development of either DFMEA or PFMEA is a process that helps to guide the teams in developing product and process designs that meet expectations.

The FMEA analysis should not be considered a single event, but a long-term commitment that complements the product and process development to ensure potential failures are evaluated and actions are taken to reduce their risk.

One key aspect of continual improvement is the retention of knowledge from past learning which often is captured in FMEAs. It is advisable for organizations to capitalize on prior analyses of similar product and process designs for use as the starting point for the next program and/or application.

The language used in FMEAs should be as specific as possible when describing an item (for example, failure mode, or cause) and not extend or extrapolate beyond the team's level of understanding as to what the failure effects may be.

Clear statements, concise terminology and focus on the actual effects are key to the effective identification and mitigation of risk issues.

Follow-up and Continuous Improvement

The need for taking effective preventive/corrective actions, with appropriate follow-up on those actions, cannot be overemphasized. Actions should be communicated to all affected activities. A thoroughly thought-out and well-developed FMEA will be of limited value without positive and effective preventive/corrective actions.

Team leadership (typically the team leader/lead engineer) is in charge of ensuring that all recommended actions have been implemented or adequately addressed. The FMEA is a living document and should always reflect the latest level, as well as the latest relevant actions, including those occurring after the start of production.

The team leader/lead engineer has several means of assuring that recommended actions are implemented. They include, but are not limited to the following:

- Reviewing designs, processes, and related records to ensure that recommended actions have been implemented,
- Confirming the incorporation of changes to design/assembly/manufacturing documentation, and,
- Reviewing Design/Process FMEAs, special FMEA applications, and Control Plans.

Chapter II

Overview of FMEA Strategy, Planning and Implementation

Introduction

FMEA development, either design or process, uses a common approach to address:

- Potential product or process failure to meet expectations
- Potential consequences
- Potential causes of the failure mode
- Application of current controls
- Level of risk
- Risk reduction

Before the FMEA document is started, the team must define the scope of the project and collect existing information which is necessary for an effective and efficient FMEA development process.

Basic Structure

The purpose of the recommended FMEA formats described in this manual is to organize the collection and display of relevant FMEA information. Specific formats may vary based on the needs of the organization and the requirements of the customer.

Fundamentally, the format utilized should address:

- Functions, requirements, and deliverables of the product or process being analyzed,
- Failure modes when functional requirements are not met,
- Effects and consequences of the failure mode,
- Potential causes of the failure mode,
- Actions and controls to address the causes of the failure mode, and,
- Actions to prevent recurrence of the failure mode.

Approach

There is no single or unique process for FMEA development; however there are common elements as described below.

Identify the Team



As previously mentioned, FMEA development is the responsibility of a multi-disciplinary (or cross-functional) team whose members encompass the necessary subject matter knowledge. This should include facilitation expertise and knowledge of the FMEA process. A team approach is recommended to benefit the FMEA development process to ensure input and collaboration from all affected functional areas.

The FMEA team leader should select team members with the relevant experience and necessary authority. In addition to the design and process engineers, the following are examples of additional resources:

FMEA development topic	Relevant Resources or Expertise
Scope	Program Management, Customer, Integration responsible individual(s)
Functions, requirements and expectations	Customer, Program Management, Integration responsible individual(s), Service Operations, Safety, Manufacturing and Assembly, Packaging, Logistics, Materials
Potential failure mode – the way a process or product might fail	Customer, Program Management, Integration responsible individual(s), Service Operations, Safety, Manufacturing and Assembly, Packaging, Logistics, Materials, Quality
Effects and consequences of the failure – to both the organization’s processes or to a downstream customer.	Customer, Program Management, Integration responsible individual(s), Service Operations, Safety, Manufacturing and Assembly, Packaging, Logistics, Materials, Quality
Causes of the potential failure	Customer, Manufacturing and Assembly, Packaging, Logistics, Materials, Quality, Reliability, Engineering Analysis, Equipment Manufacturer, Maintenance
Frequency of occurrence of potential failure	Customer, Manufacturing and Assembly, Packaging, Logistics, Materials, Quality, Reliability, Engineering Analysis, Statistical Analysis, Equipment Manufacturer, Maintenance
Application of current controls-prevention	Manufacturing and Assembly, Packaging, Logistics, Materials, Quality, Equipment Manufacturer, Maintenance
Application of current controls-detection	Customer, Manufacturing and Assembly, Packaging, Logistics, Materials, Quality, Maintenance
Recommended actions required	Customer, Program Management, Integration responsible individual(s), Manufacturing and Assembly, Packaging, Logistics, Materials, Quality, Reliability, Engineering Analysis, Statistical Analysis, Equipment Manufacturer, Maintenance

Define the Scope

Scope establishes the boundary of the FMEA analysis. It defines what is included and excluded, determined based on the type of FMEA being developed, i.e., system, subsystem, or component. Before the FMEA can begin, a clear understanding of what is to be evaluated must be determined. What to exclude can be just as important as what to include in the analysis. The scope needs to be established at the start of the process to assure consistent direction and focus.

The following may assist the team in defining the scope of the FMEA:

- Function Model
- Block (Boundary) diagrams
- Parameter (P) diagrams
- Interface diagrams
- Process flow diagrams
- Interrelationship matrices
- Schematics
- Bill of Materials (BOM)

System FMEA

A system FMEA is made up of various subsystems. Examples of systems include: Chassis System, Powertrain System, or Interior System, etc. The focus of the System FMEA is to address all interfaces and interactions among systems, subsystems, the environment and the customer.

Subsystem FMEA

A Subsystem FMEA is a subset of a system FMEA. An example of a subsystem is the front suspension subsystem, which is a subset of the chassis system. The focus of the Subsystem FMEA is to address all interfaces and interactions among the subsystem components and interactions with other subsystems or systems.

Component FMEA

A Component FMEA is a subset of a subsystem FMEA. For example, a brake pad is a component of the brake assembly, which is a subsystem of the chassis system.

NOTE: Any subsequent adjustments to the scope may require a modification of the team structure and membership.

Define the Customer

There are four major customers to be considered in the FMEA process, all need to be taken into account in the FMEA analysis:

- **END USER:** the person or organization that will utilize the product. The FMEA analysis affecting the End User could include, for example, durability.
- **OEM ASSEMBLY and MANUFACTURING CENTERS (PLANTS):** the OEM locations where manufacturing operations (e.g., stamping and powertrain) and vehicle assembly take place. Addressing the interfaces between the product and its assembly process is critical to an effective FMEA analysis.
- **SUPPLY CHAIN MANUFACTURING:** the supplier location where manufacturing, fabricating or assembling of production materials or parts takes place. This includes fabricating production and service parts and assemblies and processes such as heat treating, welding, painting, plating or other finishing services. This may be any subsequent or downstream operation or a next tier manufacturing process.
- **REGULATORS:** government agencies that define requirements and monitor compliance to safety and environmental specifications which can impact the product or process.

Knowledge of these customers can help to define the functions, requirements and specifications more robustly as well as aid in determining the effects of related failure modes.

Identify Functions, Requirements, and Specifications

Identify and understand the functions, requirements and specifications relevant to the defined scope. The purpose of this activity is to clarify the item design intent or process purpose. This assists in the determination of the potential failure mode for each attribute or aspect of the function.

Identify Potential Failure Modes

Failure mode is defined as the way or manner in which a product or process could fail to meet design intent or process requirements. The assumption is made that the failure could occur but may not necessarily occur. A concise and understandable failure definition is important since it properly focuses the analysis. Potential failure modes should be described in technical terms and not as a symptom necessarily noticeable by the customer. A large number of failure modes identified for a single requirement may indicate that the defined requirement is not concise.

Identify Potential Effects

Potential effects of failure are defined as the effects of the failure mode as perceived by the customer. The effects or impact of the failure are described in terms of what the customer might notice or experience. The customer may be an internal customer as well as the End User.

Determining potential effects includes the analysis of the consequences of the failures and the severity or seriousness of those consequences.

Identify Potential Causes

Potential cause of failure is defined as an indication of how the failure could occur, described in terms of something that can be corrected or can be controlled. Potential cause of failure may be an indication of a design weakness, the consequence of which is the failure mode.

There is a direct relation between a cause and its resultant failure mode (i.e., if the cause occurs, then the failure mode occurs). Identifying the root cause(s) of the failure mode, in sufficient detail, enables the identification of appropriate controls and action plans. A separate potential cause analysis is performed for each cause if there are multiple causes.

Identify Controls

Controls are those activities that prevent or detect the cause of the failure or failure mode. In developing controls it is important to identify what is going wrong, why, and how to prevent or detect it. Controls are applicable to product design or manufacturing processes. Controls focused on prevention will provide the greatest return.

Identifying and Assessing Risk

One of the important steps in the FMEA process is the assessment of risk. This is evaluated in three ways, severity, occurrence, and detection:

Severity is an assessment of the level of impact of a failure on the customer.

Occurrence is how often the cause of a failure may occur.

Detection is an assessment of how well the product or process controls detect the cause of the failure or the failure mode.

Organizations need to understand their customer requirements for risk assessment.

Recommended Actions and Results

The intent of recommended actions is to reduce overall risk and likelihood that the failure mode will occur. The recommended actions address reduction of the severity, occurrence and detection.

The following can be used to assure that the appropriate actions are taken, including but not limited to:

- Ensuring design requirements including reliability are achieved,
- Reviewing engineering drawings and specifications,
- Confirming incorporation in assembly/manufacturing processes, and,
- Reviewing related FMEAs, control plans and operations instructions.

Responsibility and timing to complete the recommended actions should be recorded.

Once actions are completed and results captured, the updated ratings for severity, occurrence and detection should also be recorded.

Management Responsibility



Management owns the FMEA process. Management has the ultimate responsibility of selecting and applying resources and ensuring an effective risk management process including timing.

Management responsibility also includes providing direct support to the team through on-going reviews, eliminating roadblocks, and incorporating lessons learned.

Chapter III

DFMEA

Design Failure Mode and Effects Analysis

Introduction

The Design Failure Mode Effects Analysis, referred to as DFMEA, supports the design process in reducing the risk of failures by:

- Aiding in the objective evaluation of the design, including functional requirements and design alternatives,
- Evaluating the initial design for manufacturing, assembly, service, and recycling requirements,
- Increasing the probability that potential failure modes and their effects on system and vehicle operation have been considered in the design/development process,
- Providing additional information to aid in the planning of thorough and efficient design, development, and validation programs,
- Developing a ranked list of potential failure modes according to their effect on the customer, thus establishing a priority system for design improvements, development, and validation testing/analysis,
- Providing an open issue format for recommending and tracking risk-reducing actions, and,
- Providing future reference, (e.g., lessons learned), to aid in addressing field concerns, evaluating design changes, and developing advanced designs.

The DFMEA is a living document and should:

- Be initiated before design concept finalization,
- Be updated as changes occur or additional information is obtained throughout the phases of product development,
- Be fundamentally completed before the production design is released, and,
- Be a source of lessons learned for future design iterations.

Customer Defined

The definition of “Customer” provided in Chapter II applies to DFMEA. It is important to correctly identify the customer(s) because such knowledge directs the development of the DFMEA, including the impact of the function of the design.

Team Approach

The DFMEA is developed and maintained by a multi-disciplinary (or cross-functional) team typically led by the design responsible engineer from the responsible design source (e.g., OEM, Tier 1 supplier or Tier 2 supplier and below).

The responsible engineer is expected to directly and actively involve representatives from all affected areas. The areas of expertise and responsibility may include, but are not limited to, assembly, manufacturing, design, analysis/test, reliability, materials, quality, service, and suppliers, as well as the design area responsible for the next higher or lower assembly or system, subsystem, or component.

Manufacturing, Assembly and Serviceability Considerations

The DFMEA should include any potential failure modes and causes that can occur during the manufacturing or assembly process which are the result of the design. Such failure modes may be mitigated by design changes (e.g., a design feature which prevents a part from being assembled in the wrong orientation – i.e., error-proofed). When not mitigated during the DFMEA analysis (as noted in the action plan for that item), their identification, effect, and control should be transferred to and covered by the PFMEA.

The DFMEA does not rely on process controls to overcome potential design weaknesses, but it does take the technical and physical limits of a manufacturing and assembly process into consideration, for example:

- Necessary mold drafts
- Limited surface finish capability
- Assembling space (e.g., access for tooling)
- Limited hardenability of steels
- Tolerances/process capability/performance

The DFMEA can also take into consideration the technical and physical limits of product serviceability and recycling once the product has entered field use, for example:

- Tool access
- Diagnostic capability
- Material classification symbols (for recycling)
- Materials/chemicals used in the manufacturing processes

Development of a Design FMEA

The DFMEA focuses on the design of the product that will be delivered to the final customer (End User). The prerequisite tasks for an effective analysis of the product design include: assembling a team, determining scope, creating block diagrams or P-diagrams depicting product function and requirements. A clear and complete definition of the desired product characteristics better facilitates the identification of potential failure modes. A DFMEA form is used to document the results of the analysis including any recommended actions and responsibilities (See Table III.1).

The DFMEA process can be mapped to the customer or organization's product development process.

Prerequisites

A DFMEA should begin with the development of information to understand the system, subsystem, or component being analyzed and define their functional requirements and characteristics.

In order to determine the scope of the DFMEA, the team should consider the following as applicable to component, subsystem or system DFMEAs:

- What processes, mating components, or systems does the product interface with?
- Are there functions or features of the product that affect other components or systems?
- Are there inputs provided by other components or systems that are needed to perform intended functions of the product?
- Do the product's functions include the prevention or detection of a possible failure mode in a linked component or system?

The following sections describe tools that may be applied, as appropriate, to assist the team in developing the DFMEA.

Block (Boundary) Diagrams

The block diagram of the product shows the physical and logical relationships between the components of the product. There are different approaches and formats to the construction of a block diagram

The block diagram indicates the interaction of components and subsystems within the scope of the design. This interaction may include: flow of information, energy, force, or fluid. The objective is to understand the requirements or inputs to the

system, the activities acting on the inputs or function performed, and the deliverables or output.

The diagram may be in the form of boxes connected by lines, with each box corresponding to a major component of the product or a major step of the process. The lines correspond to how the product components are related to, or interface with each other. The organization needs to decide the best approach or format for the block diagram. Figure III.1a, b, and c contain examples of block diagrams.

Copies of the diagrams used in DFMEA preparation should accompany the DFMEA.

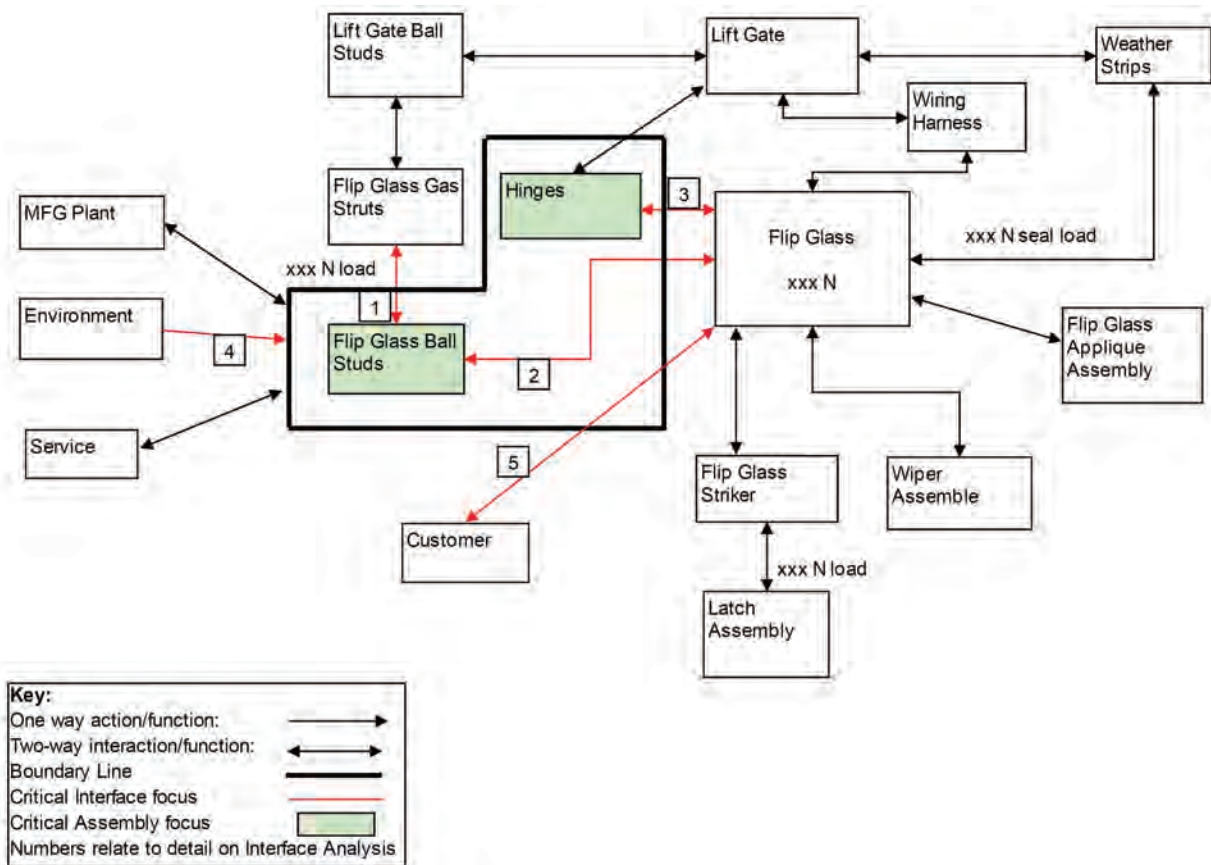
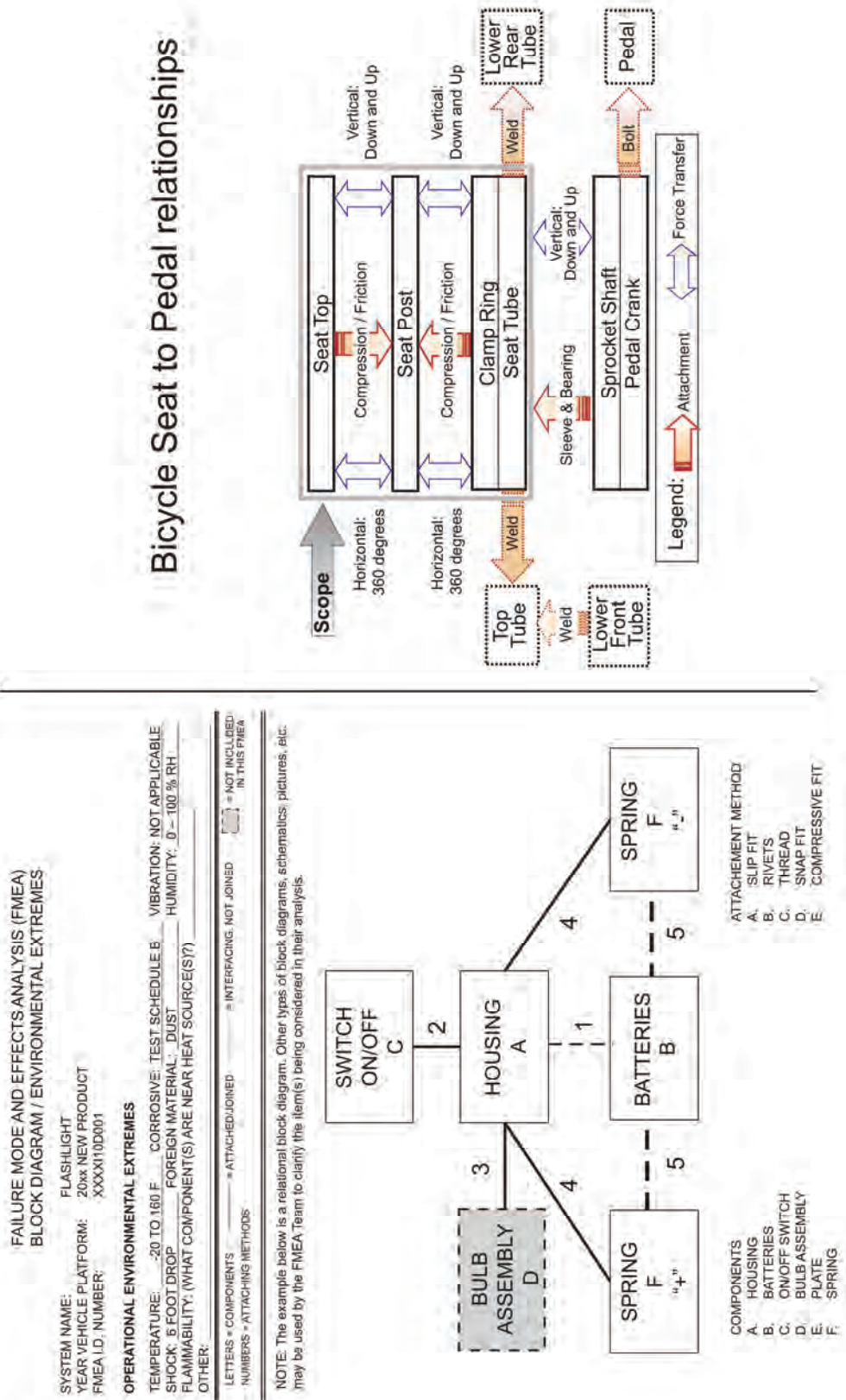

Figure III.1a Block (Boundary) Diagram Examples



Figures III.1b, c Block (Boundary) Diagram Examples

Parameter (P) Diagrams

The P-Diagram is a structured tool to help the team understand the physics related to the function(s) of the design. The team analyzes the intended inputs (signals) and outputs (responses or functions) for the design as well as those controlled and uncontrolled factors which can impact performance.

The inputs to the product and outputs from the product, i.e., the intended and unintended functions of the product, are useful in identifying error states, noise factors, and control factors.

The error states correspond to the Potential Failure Modes in the DFMEA.

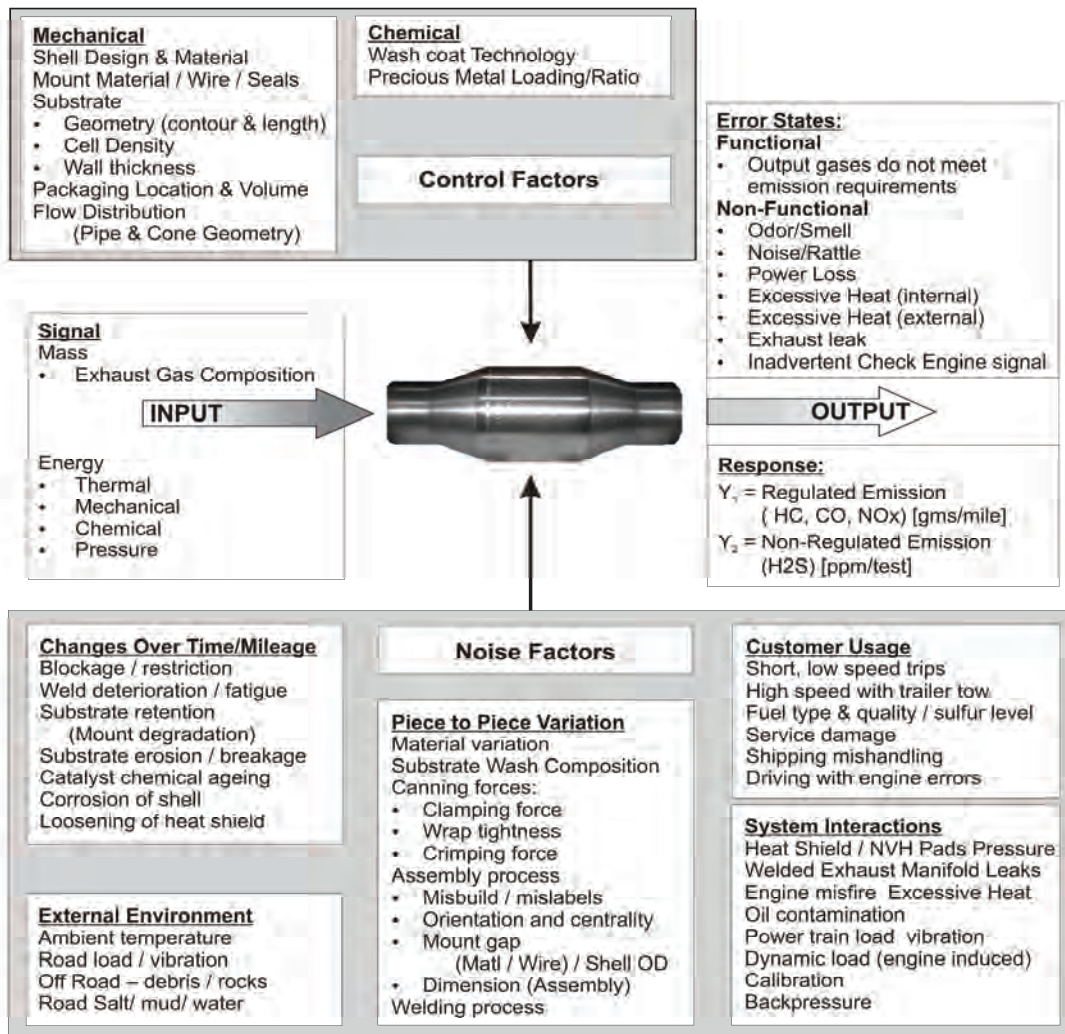

Figure III.2 Example of a Parameter (P) Diagram for a Generic Catalytic Converter

Functional Requirements

Another step in the DFMEA process is a compilation of the functional and interface requirements of the design. This list may include the following categories:

- General: This category considers the purpose of the product and its overall design intent
- Safety
- Government Regulations
- Reliability (Life of the Function)
- Loading and Duty Cycles: Customer product usage profile
- Quiet Operations: Noise, vibration and harshness (NVH)
- Fluid Retention
- Ergonomics
- Appearance
- Packaging and Shipping
- Service
- Design for Assembly
- Design for Manufacturability

Other Tools and Information Resources

Other tools and resources that may help the team understand and define the design requirements may include:

- Schematics, drawings, etc.
- Bill of Materials (BOM)
- Interrelationship matrices
- Interface matrix
- Quality Function Deployment (QFD)
- Quality and Reliability History

The use of these tools, supported by engineering experience and historical information, can assist in defining a comprehensive set of requirements and functions.

After considering these prerequisites, start filling out the form (Table III.1 below).

This page intentionally left blank.

POTENTIAL
FAILURE MODE AND EFFECTS ANALYSIS
(DESIGN FMEA)

____ System
____ Subsystem
____ Component **B**
Model Year(s)/Program(s) **D**
Core Team **G**

Design Responsibility **C**
Key Date **E**

FMEA Number **A**
Page _____ of _____
Prepared By: **H**
FMEA Date (Orig.) **F**

Table III.1 Sample DFMEA Form with Minimal Information Elements & Example Entries

Item Function	Requirement	Potential Failure Mode	Potential Effect(s) of Failure	Severity	Classification	Potential Cause(s) of Failure	Current Design				Recommended Action	Responsibility & Target Completion Date	Action Results					
							Controls Prevention	Occurrence	Controls Detection	Detection			RPN	Actions Taken Completion Date	Severity	Occurrence	Detection	RPN
Front Door L.H. H8HX-0000-A	Maintain integrity of inner door panel	Integrity breach allows environ. access of inner door panel	Corroded interior lower door panels Deteriorated life of door leading to: •Unsatisfactory appearance due to rust through paint over time. • Impaired function of interior door hardware	5		Upper edge of protective wax application specified for inner door panels is too low	Design requirements (#31268) and best practice (BP 3455)	3	Vehicle durability test. T-118 (7)	7	105	Laboratory accelerated corrosion test	A. Tate Body Engineer 0X 09 03	Based on test results (test no. 1481) upper edge spec raised 125 0X 09 30	5	2	3	30
						Insufficient wax thickness specified	Design requirements (#31268) and best practice (BP 3455)	3	Vehicle durability test. T-118 (7)	7	105	Laboratory accelerated corrosion test	A. Tate Body Engineer 0X 09 03	Test results (Test No. 1481) show specified thickness is adequate. 0X 09 30	5	2	3	30
											Design of Experiments (DOE) on Wax Thickness	J. Smythe Body Engineer 0X 10 18	DOE shows 25% variation in specified thickness is acceptable 0X 10 25	5	2	3	30	
						Inappropriate wax formulation specified	Industry standard MS-1893	2	Physical and Chemical Lab test - Report No. 1265 (5) Vehicle durability test. T-118 (7)	5	50	None						
						Corner design prevents spray equip from reaching all areas		5	Design aid with non-functioning spray head (8) Vehicle durability test. T-118 (7)	7	175	Team evaluation using production spray equipment and specified wax	T. Edwards Body Engineer and Assy Ops 0X 11 15	Based on test: 3 additional vent holes provided in affected areas (error-proofed) 0X 12 15	5	1	1	5
						Insufficient room between panels for spray head access		4	Drawing evaluation of spray head access (4) Vehicle durability test. T-118 (7)	4	80	Team evaluation using design aid buck and spray head	Body Engineer and Assy Ops 0X 11 15	Evaluation showed adequate access 0X 12 15	5	2	4	40
a1	a2	b	c	d	e	f	h	g	h	i	j	k	l	m	---	n	---	

SAMPLE

Example DFMEA

The example used with the sample form deals with a Front Door assembly. The product has several functional requirements:

- Permit ingress to and egress from vehicle
- Provide occupant protection from
 - Weather (comfort)
 - Noise (comfort)
 - Side impact (safety)
- Support anchorage for door hardware including
 - Mirror
 - Hinges
 - Latch
 - Window regulator
- Provide proper surface for appearance items
 - Paint
 - Soft trim
- Maintain integrity of inner door panel

The final DFMEA would include analysis of all these requirements. The example includes part of the analysis of the requirement: “Maintain integrity of inner door panel”.

Header of the Design FMEA Form (fields A-H)

The following describes the information to be entered on the form.

The header should clearly identify the focus of the FMEA as well as information related to the document development and control process. This should include an FMEA number, identification of the scope, design responsibility, completion dates, etc. The header should contain the following elements²:

² The letters at the end of each heading indicate the area referred to on the sample form.

POTENTIAL FAILURE MODE AND EFFECTS ANALYSIS (DESIGN FMEA)

FMEA Number A of pages

Page H of

Prepared By: F

FMEA Date (Orig.)

Design Responsibility C

Key Date E

System

Subsystem

Component B

Model Year(s)/Program(s) D

Core Team G

Item / Function	Requirement	Potential Failure Mode	Potential Effect(s) of Failure	Severity	Classification	Potential Cause(s) of Failure	Current Design		RPN	Recommended Action	Responsibility & Target Completion Date	Action Results				
							Controls Prevention	Controls Detection				Completion Date	Severity	Occurrence	Detection	RPN
Front Door, LH HBH-K-000-0-A	Maintain integrity of inner door panel	Integrity breach allows environ. access of inner door panel	Corroded interior lower door panels Deteriorated life of door leading to: •Unsatisfactory appearance due to rust through paint over time. •Impaired function of interior door hardware	5		Upper edge of protective wax formulation for inner door panels is too low Insufficient wax thickness specified	Design requirements (#31268) and best practice (BP-3455)	Vehicle durability test T-118 (7)	105	Laboratory accelerated corrosion test	A. Tate Body Engineer OX 09 03	Based on test results (test no. 1481) upper edge spec raised 125 OX 09 30	5	2	3	30
						Inappropriate wax formulation specified	Design requirements (#31268) and best practice (BP-3455)	Vehicle durability test T-118 (7)	105	Laboratory accelerated corrosion test	A. Tate Body Engineer OX 09 03	Test results (Test No. 1481) show specified thickness is adequate. OX 09 30	5	2	3	30
						Inappropriate wax formulation specified	Industry standard MS-1633	Physical and Chemical Lab test - Report No. 1265 (5) Vehicle durability test T-118 (7)	50	None	J. Smythe Body Engineer OX 10 18	DOE shows 25% variation in specified thickness is acceptable OX 10 25				
						Corner design prevents spray equip from reaching all areas		Design aid with non-functioning spray head (8) Vehicle durability test T-118 (7)	175	Team evaluation using production spray equipment and specified wax	T. Edwards Body Engineer and Assy Ops OX 11 15	Based on test: 3 additional vent holes provided in affected areas (error-proofed) OX 12 15	5	1	1	5
						Insufficient room between panels for spray head access		Drawing evaluation of spray head access (4) Vehicle durability test T-118 (7)	80	Team evaluation using design aid buck and spray head	Body Engineer and Assy Ops OX 11 15	Evaluation showed adequate access OX 12 15	5	2	4	40
a1	a2	b	c	d	e	f	g	h	i	j	k	l	m	n	o	p

SAMPLE

Table III.1 Sample DFMEA Form with Minimal Information Elements & Example Entries

FMEA Number (A)

Enter an alphanumeric string which is used to identify the FMEA document. This is used for document control.

System, Subsystem, or Component Name and Number (B)

Enter the name and number of the system, subsystem, or component which is being analyzed. (See section entitled Define the Scope).

Design Responsibility (C)

Enter the OEM, organization, and department or group who is design responsible. Also enter the supply organization name, if applicable.

Model Year(s)/Program(s) (D)

Enter the intended model year(s) and program(s) that will use or be affected by the design being analyzed (if known).

Key Date (E)

Enter the initial DFMEA due date, which should not exceed the scheduled production design release date.

FMEA Dates (F)

Enter the date the original DFMEA was completed and the latest revision date.

Core Team (G)

Enter the team members responsible for developing the DFMEA. Contact information (e.g., name, organization, telephone number, and email) may be included in a referenced supplemental document.

Prepared By (H)

Enter the name and contact information including the organization (company) of the engineer responsible for preparing the DFMEA.

POTENTIAL FAILURE MODE AND EFFECTS ANALYSIS (DESIGN FMEA)

System _____ FMEA Number A

Subsystem _____ Page _____ of _____

Component B Prepared By: H

Model Year(s)/Program(s) D Design Responsibility C

G Key Date _____ FMEA Date (Orig.) F

Core Team _____

Item / Function	Requirement	Potential Failure Mode	Potential Effect(s) of Failure	Severity	Classification	Potential Cause(s) of Failure	Current Design			Recommended Action	Responsibility & Target Completion Date	Action Results					
							Controls Prevention	Controls Detection	RPN			Actions Taken	Completion Date	Severity	Occurrence	Detection	RPN
Front Door, LH HBH-K-000-0-A	Maintain integrity of inner door panel	Integrity breach allows environ. access of inner door panel	Corroded interior lower door panels Deteriorated life of door leading to: • Unsatisfactory appearance due to rust through paint over time. • Impaired function of interior door hardware	5		Upper edge of protective wax formulation for inner door panels is too low Insufficient wax thickness specified	Design requirements (#31268) and best practice (BP 3455)	Vehicle durability test T-118 (7)	105	Laboratory accelerated corrosion test	A. Tate Body Engineer OX 09 03	Based on test results (test no. 1481) upper edge spec raised 125 OX 09 30	5	2	3	30	
						Inappropriate wax formulation specified	Industry standard MS-1633	Physical and Chemical Lab test - Report No. 1265 (5) Vehicle durability test T-118 (7)	50	None							
		Corner design prevents spray equip from reaching all areas						Design aid with non-functioning spray head (8) Vehicle durability test T-118 (7)	175	Team evaluation using production spray equipment and specified wax	T. Edwards Body Engineer and Assy Ops OX 11 15	Based on test: 3 additional vent holes provided in affected areas (error-proofed) OX 12 15	5	1	1	5	
		Insufficient room between panels for spray head access						Drawing evaluation of spray head access (4) Vehicle durability test T-118 (7)	80	Team evaluation using design aid buck and spray head	Body Engineer and Assy Ops OX 11 15	Evaluation showed adequate access OX 12 15	5	2	4	40	
a1	a2	b	c	d	e	f	h	g	h	i	j	k	l	m	n	o	

SAMPLE

Table III.1 Sample DFMEA Form with Minimal Information Elements & Example Entries

Body of the DFMEA Form (fields a – n)

The body of the FMEA contains the analysis of risks related to the potential failures, and improvement action being taken.³

Item / Function / Requirements (a)

Item/Function can be separated into two (or more) columns or combined into a single, bridged column which encompasses these elements. Interfaces (as “items” of analysis) can be either combined or separate. Components may be listed in the item/function column, and an additional column may be added containing the functions or requirements of that item. “Item”, “Function”, and “Requirements” are described below:

Item (a1)

Enter the items, interfaces, or parts which have been identified through block diagrams, P-diagrams, schematics and other drawings, and other analysis conducted by the team.

The terminology used should be consistent with customer requirements and with those used in other design development documents and analysis to ensure traceability.

Function (a1)

Enter the function(s) of the item(s) or interface(s) being analyzed which are necessary to meet the design intent based on customer requirements and the team’s discussion. If the item(s) or interface has more than one function with different potential modes of failure, it is highly recommended that each of these functions and associated failure mode(s) is listed separately.

Function becomes a2 if Item and Function are split.

Requirements (a2)

An additional column, “Requirements”, may be added to further refine the analysis of the failure mode(s). Enter the requirement(s) for each of the functions being analyzed (based on customer requirements and the team’s discussion; see also Chapter II, Section: Prerequisites). If the function has more than one requirement with different potential modes of failure, it is highly recommended that each of the requirements and functions are listed separately.

Requirement becomes a3 if Item and Function are split into separate columns, e.g., a1 and a2.

³ The letters at the end of each heading indicate the area referred to on the sample form.

POTENTIAL FAILURE MODE AND EFFECTS ANALYSIS (DESIGN FMEA)

FMEA Number: A of pages

Page: H of pages

Prepared By: F

FMEA Date (Orig.):

Design Responsibility: C

Key Date: E

System:

Subsystem:

Component: B

Model Year(s)/Program(s): D

Core Team: G

Item / Function	Requirement	Potential Failure Mode	Potential Effect(s) of Failure	Severity	Classification	Potential Cause(s) of Failure	Current Design		RPN	Recommended Action	Responsibility & Target Completion Date	Action Results				
							Controls Prevention	Controls Detection				Completion Date	Severity	Occurrence	Detection	
Front Door, LH HBH-K-000-0-A	Maintain integrity of inner door panel	Integrity breach allows environ. access of inner door panel	Corroded interior lower door panels Deteriorated life of door leading to: • Unsatisfactory appearance due to rust through paint over time. • Impaired function of interior door hardware	5		Upper edge of protective wax formulation for inner door panels is too low Insufficient wax thickness specified	Design requirements (#31268) and best practice (BP-3455)	Vehicle durability test T-118 (7)	105	Laboratory accelerated corrosion test	A. Tate Body Engineer OX 09 03	Based on test results (test no. 1481) upper edge spec raised 125 OX 09 30	5	2	3	30
						Inappropriate wax formulation specified	Design requirements (#31268) and best practice (BP-3455)	Vehicle durability test T-118 (7)	105	Laboratory accelerated corrosion test	A. Tate Body Engineer OX 09 03	Test results (Test No. 1481) show specified thickness is adequate. OX 09 30	5	2	3	30
						Inappropriate wax formulation specified	Industry standard MS-1633	Physical and Chemical Lab test - Report No. 1265 (5) Vehicle durability test T-118 (7)	50	None	J. Smythe Body Engineer OX 10 18	DOE shows 25% variation in specified thickness is acceptable OX 10 25				
						Corner design prevents spray equip from reaching all areas		Design aid with non-functioning spray head (8) Vehicle durability test T-118 (7)	175	Team evaluation using production spray equipment and specified wax	T. Edwards Body Engineer and Assy Ops OX 11 15	Based on test: 3 additional vent holes provided in affected areas (error-proofed) OX 12 15	5	1	1	5
						Insufficient room between panels for spray head access		Drawing evaluation of spray head access (4) Vehicle durability test T-118 (7)	80	Team evaluation using design aid buck and spray head	Body Engineer and Assy Ops OX 11 15	Evaluation showed adequate access OX 12 15	5	2	4	40
a1	a2	b	c	d	e	f	g	h	i	j	k	l	m	n	o	p

SAMPLE

Table III.1 Sample DFMEA Form with Minimal Information Elements & Example Entries

Potential Failure Mode (*b*)

Potential failure mode is defined as the manner in which a component, subsystem, or system could potentially fail to meet or deliver the intended function described in the item column.

Identify the potential failure mode(s) associated with the function(s)/requirement(s). Potential failure modes should be described in technical terms, and not necessarily as a symptom noticeable by the customer.

Each function may have multiple failure modes. A large number of failure modes identified for a single function may indicate that the requirement is not well defined.

The assumption is made that the failure could occur, but may not necessarily occur, consequently the use of the word “potential”.

Potential failure modes that could occur only under certain operating conditions (i.e., hot, cold, dry, dusty, etc.) and under certain usage conditions (i.e., above-average mileage, rough terrain, city driving only, etc.) should be considered.

After determining all the failure modes, a validation of the completeness of the analysis can be made through a review of past things-gone-wrong, concerns, reports, and group brainstorming.

The potential failure mode may also be the cause of a potential failure mode in a higher level subsystem or system, or lead to the effect of one in a lower level component.

Example failure modes, as related to different requirements, are shown in table III.3.

Item	Function	Requirement	Failure Mode
Disk Brake system	Stop vehicle on demand (considering environmental conditions such as wet, dry, etc.)	Stop vehicle traveling on dry asphalt pavement within specified distance within specified g's of force	Vehicle does not stop
			Vehicle stops in excess of specified distance
			Stops vehicle with more than xx g's of force
		Allow unimpeded vehicle movement on no system demand	Activates with no demand; Vehicle movement is partially impeded
			Activates with no demand Vehicle cannot move
Brake Rotor	Allows transfer of force from brake pads to axle	Must deliver specified torque resistance at axle	Insufficient torque resistance delivered

Table III.3 Example Potential Failure Modes

This page intentionally left blank.

POTENTIAL FAILURE MODE AND EFFECTS ANALYSIS (DESIGN FMEA)

System _____ FMEA Number A

Subsystem _____ Page _____ of _____

Component B Prepared By: H

Model Year(s)/Program(s) D Design Responsibility C

G Key Date _____ FMEA Date (Orig.) F

Core Team _____

Item / Function	Requirement	Potential Failure Mode	Potential Effect(s) of Failure	Severity	Classification	Potential Cause(s) of Failure	Current Design			Recommended Action	Responsibility & Target Completion Date	Action Results					
							Controls Prevention	Controls Detection	RPN			Actions Taken	Completion Date	Severity	Occurrence	Detection	RPN
Front Door, LH HBH-K-000-0-A	Maintain integrity of inner door panel	Integrity breach allows environ. access of inner door panel	Corroded interior lower door panels Deteriorated life of door leading to: • Unsatisfactory appearance due to rust through paint over time. • Impaired function of interior door hardware	5		Upper edge of protective wax formulation for inner door panels is too low Insufficient wax thickness specified	Design requirements (#31268) and best practice (BP-3455)	Vehicle durability test T-118 (7)	105	Laboratory accelerated corrosion test	A. Tate Body Engineer OX 09 03	Based on test results (test no. 1481) upper edge spec raised 125 OX 09 30	5	2	3	30	
						Inappropriate wax formulation specified	Industry standard MS-1633	Physical and Chemical Lab test - Report No. 1265 (5) Vehicle durability test T-118 (7)	50	None							
		Corner design prevents spray equip from reaching all areas						Design aid with non-functioning spray head (8) Vehicle durability test T-118 (7)	175	Team evaluation using production spray equipment and specified wax	T. Edwards Body Engineer and Assy Ops OX 11 15	Based on test: 3 additional vent holes provided in affected areas (error-proofed) OX 12 15	5	1	1	5	
		Insufficient room between panels for spray head access						Drawing evaluation of spray head access (4) Vehicle durability test T-118 (7)	80	Team evaluation using design aid buck and spray head	Body Engineer and Assy Ops OX 11 15	Evaluation showed adequate access OX 12 15	5	2	4	40	
a1	a2	b	c	d	e	f	h	g	ij	k	l	m	n	o	p	q	r

Table III.1 Sample DFMEA Form with Minimal Information Elements & Example Entries

Potential Effect(s) of Failure (c)

Potential effects of failure are defined as the effects of the failure mode on the function, as perceived by the customer(s).

Describe the effects of the failure in terms of what the customer might notice or experience, remembering that the customer may be an internal customer as well as the ultimate End User. State clearly if the failure mode could impact safety or non-compliance to regulations. The effects should always be stated in terms of the specific system, subsystem, or component being analyzed. Remember that a hierarchical relationship exists between the component, subsystem, and system levels⁴. For example, a part could fracture, which may cause the assembly to vibrate, resulting in an intermittent system operation. The intermittent system operation could cause performance to degrade and ultimately lead to customer dissatisfaction. The intent is to predict the potential failure effects to the team's level of knowledge.

Typical failure effects should be stated in terms of product or system performance. Table III.4 shows example effects of the failure modes from Table III.3.

Item	Failure Mode	Effect
Disk Brake System	Vehicle does not stop	Vehicle control impaired; Regulatory non-compliance
	Vehicle stops in excess of specified distance	Vehicle control impaired; Regulatory non-compliance
	Stops vehicle with more than xx g's of force	Regulatory non-compliance
	Activates with no demand; Vehicle movement is partially impeded	Decreased pad life; diminished vehicle control
	Activates with no demand Vehicle cannot move	Customer unable to drive vehicle

Table III.4 Example Potential Effects

⁴ See also Appendix B

POTENTIAL FAILURE MODE AND EFFECTS ANALYSIS (DESIGN FMEA)

FMEA Number: A of pages

Page: H of pages

Prepared By: F

FMEA Date (Orig.):

Design Responsibility: C

Key Date: E

System:

Subsystem:

Component: B

Model Year(s)/Program(s): D

Core Team: G

Item / Function	Requirement	Potential Failure Mode	Potential Effect(s) of Failure	Severity	Classification	Potential Cause(s) of Failure	Current Design		RPN	Recommended Action	Responsibility & Target Completion Date	Action Results				
							Controls Prevention	Controls Detection				Actions Taken	Completion Date	Severity	Occurrence	Detection
Front Door, LH HBH-K-000-0-A	Maintain integrity of inner door panel	Integrity breach allows environ. access of inner door panel	Corroded interior lower door panels Deteriorated life of door leading to: • Unsatisfactory appearance due to rust through paint over time. • Impaired function of interior door hardware	5		Upper edge of protective wax formulation for inner door panels is too low Insufficient wax thickness specified	Design requirements (#31268) and best practice (BP-3455)	Vehicle durability test T-118 (7)	105	Laboratory accelerated corrosion test	A. Tate Body Engineer OX 09 03	Based on test results (test no. 1481) upper edge spec raised 125 OX 09 30	5	2	3	30
						Inappropriate wax formulation specified	Design requirements (#31268) and best practice (BP-3455)	Vehicle durability test T-118 (7)	105	Laboratory accelerated corrosion test	A. Tate Body Engineer OX 09 03	Test results (Test No. 1481) show specified thickness is adequate. OX 09 30	5	2	3	30
						Inappropriate wax formulation specified	Industry standard MS-1633	Physical and Chemical Lab test - Report No. 1265 (5) Vehicle durability test T-118 (7)	50	None	J. Smythe Body Engineer OX 10 18	DOE shows 25% variation in specified thickness is acceptable OX 10 25				
						Corner design prevents spray equip from reaching all areas		Design aid with non-functioning spray head (8) Vehicle durability test T-118 (7)	175	Team evaluation using production spray equipment and specified wax	T. Edwards Body Engineer and Assy Ops OX 11 15	Based on test: 3 additional vent holes provided in affected areas (error-proofed) OX 12 15	5	1	1	5
						Insufficient room between panels for spray head access		Drawing evaluation of spray head access (4) Vehicle durability test T-118 (7)	80	Team evaluation using design aid buck and spray head	Body Engineer and Assy Ops OX 11 15	Evaluation showed adequate access OX 12 15	5	2	4	40
a1	a2	b	c	d	e	f	g	h	i	j	k	l	m	n	o	p

SAMPLE

Table III.1 Sample DFMEA Form with Minimal Information Elements & Example Entries

Severity (S) (d)

Severity is the value associated with the most serious effect for a given failure mode. Severity is a relative ranking within the scope of the individual FMEA.

Suggested Evaluation Criteria

The team should agree on evaluation criteria and a ranking system and apply them consistently, even if modified for individual process analysis. (See Table Cr1 below for criteria guidelines.)

It is not recommended to modify criteria ranking values of 9 and 10. Failure modes with a rank of severity 1 should not be analyzed further.

Effect	Criteria: Severity of Effect on Product (Customer Effect)	Rank
Failure to Meet Safety and/or Regulatory Requirements	Potential failure mode affects safe vehicle operation and/or involves noncompliance with government regulation without warning.	10
	Potential failure mode affects safe vehicle operation and/or involves noncompliance with government regulation with warning.	9
Loss or Degradation of Primary Function	Loss of primary function (vehicle inoperable, does not affect safe vehicle operation).	8
	Degradation of primary function (vehicle operable, but at reduced level of performance).	7
Loss or Degradation of Secondary Function	Loss of secondary function (vehicle operable, but comfort / convenience functions inoperable).	6
	Degradation of secondary function (vehicle operable, but comfort / convenience functions at reduced level of performance).	5
Annoyance	Appearance or Audible Noise, vehicle operable, item does not conform and noticed by most customers (> 75%).	4
	Appearance or Audible Noise, vehicle operable, item does not conform and noticed by many customers (50%).	3
	Appearance or Audible Noise, vehicle operable, item does not conform and noticed by discriminating customers (< 25%).	2
No effect	No discernible effect.	1

Table Cr1 Suggested DFMEA Severity Evaluation Criteria

POTENTIAL FAILURE MODE AND EFFECTS ANALYSIS (DESIGN FMEA)

FMEA Number: A of pages

Page: H of pages

Prepared By: F

FMEA Date (Orig.):

Design Responsibility: C

Key Date: E

System:

Subsystem:

Component: B

Model Year(s)/Program(s): D

Core Team: G

Item / Function	Requirement	Potential Failure Mode	Potential Effect(s) of Failure	Severity	Classification	Potential Cause(s) of Failure	Current Design		RPN	Recommended Action	Responsibility & Target Completion Date	Action Results				
							Controls Prevention	Controls Detection				Actions Taken	Completion Date	Severity	Occurrence	Detection
Front Door, LH HBH-K-000-0-A	Maintain integrity of inner door panel	Integrity breach allows environ. access of inner door panel	Corroded interior lower door panels Deteriorated life of door leading to: • Unsatisfactory appearance due to rust through paint over time. • Impaired function of interior door hardware	5		Upper edge of protective wax formulation for inner door panels is too low Insufficient wax thickness specified	Design requirements (#31268) and best practice (BP-3455)	Vehicle durability test T-118 (7)	105	Laboratory accelerated corrosion test	A. Tate Body Engineer OX 09 03	Based on test results (test no. 1481) upper edge spec raised 125 OX 09 30	5	2	3	30
						Inappropriate wax formulation specified	Design requirements (#31268) and best practice (BP-3455)	Vehicle durability test T-118 (7)	105	Laboratory accelerated corrosion test	A. Tate Body Engineer OX 09 03	Test results (Test No. 1481) show specified thickness is adequate. OX 09 30	5	2	3	30
						Inappropriate wax formulation specified	Industry standard MS-1633	Physical and Chemical Lab test - Report No. 1265 (5) Vehicle durability test T-118 (7)	50	None	J. Smythe Body Engineer OX 10 18	DOE shows 25% variation in specified thickness is acceptable OX 10 25				
						Corner design prevents spray equip from reaching all areas		Design aid with non-functioning spray head (8) Vehicle durability test T-118 (7)	175	Team evaluation using production spray equipment and specified wax	T. Edwards Body Engineer and Assy Ops OX 11 15	Based on test: 3 additional vent holes provided in affected areas (error-proofed) OX 12 15	5	1	1	5
						Insufficient room between panels for spray head access		Drawing evaluation of spray head access (4) Vehicle durability test T-118 (7)	80	Team evaluation using design aid buck and spray head	Body Engineer and Assy Ops OX 11 15	Evaluation showed adequate access OX 12 15	5	2	4	40
a1	a2	b	c	d	e	f	g	h	i	j	k	l	m	n	o	p

SAMPLE

Table III.1 Sample DFMEA Form with Minimal Information Elements & Example Entries

Classification (e)

This column may be used to highlight high-priority failure modes and their associated causes.

As a result of this analysis, the team may use this information to identify special characteristics.

Customer specific requirements may identify special product or process characteristic symbols and their usage.

A characteristic designated in the design record as special without an associated design failure mode identified in the DFMEA is an indication of a weakness in the design process.

Potential Cause(s)/Mechanism(s) of Failure Mode (f)

This information can be separated into multiple columns or combined into a single column.

In the development of the FMEA, the identification of all potential causes of the failure mode is key to subsequent analysis. Although varied techniques (such as brainstorming) can be used to determine the potential cause(s) of the failure mode, it is recommended that the team should focus on an understanding of the *failure mechanism* for each failure mode.

Potential Mechanism(s) of Failure Mode (f1)

A failure mechanism is the physical, chemical, electrical, thermal, or other process that results in the failure mode. It is important to make the distinction that a failure mode is an "observed" or "external" effect so as not to confuse failure mode with failure mechanism, the actual physical phenomenon behind the failure mode or the process of degradation or chain of events leading to and resulting in a particular failure mode.

To the extent possible, list every potential mechanism for each failure mode. The mechanism should be listed as concisely and completely as possible.

For a system, the failure mechanism is the process of error propagation following a component failure which leads to a system failure.

A product or process can have several failure modes which are correlated to each other because of a common failure mechanism behind them.

Ensure that process effects are considered as part of the DFMEA process.

POTENTIAL
FAILURE MODE AND EFFECTS ANALYSIS
(DESIGN FMEA)

FMEA Number A
Page H of F
Prepared By: F
FMEA Date (Orig.) _____

Design Responsibility C
Key Date _____

Design Responsibility E
Key Date _____

System _____
Subsystem _____
Component B
Model Year(s)/Program(s) D
Core Team _____

Item / Function	Requirement	Potential Failure Mode	Potential Effect(s) of Failure	Severity	Classification	Potential Cause(s) of Failure	Current Design		RPN	Recommended Action	Responsibility & Target Completion Date	Action Results					
							Controls Prevention	Controls Detection				Completion Date	Severity	Occurrence	Detection	RPN	
Front Door, LH HBH-K-000-0-A	Maintain integrity of inner door panel	Integrity breach allows environ. access of inner door panel	Corroded interior lower door panels Deteriorated life of door leading to: • Unsatisfactory appearance due to rust through paint over time. • Impaired function of interior door hardware	5		Upper edge of protective wax formulation for inner door panels is too low Insufficient wax thickness specified	Design requirements (#31268) and best practice (BP-3455) Design requirements (#31268) and best practice (BP-3455)	Vehicle durability test T-118 (7) Vehicle durability test T-118 (7)	105 105	Laboratory accelerated corrosion test Laboratory accelerated corrosion test	A. Tate Body Engineer OX 09 03 A. Tate Body Engineer OX 09 03	Based on test results (test no. 1481) upper edge spec raised 125 OX 09 30 Test results (Test No. 1481) show specified thickness is adequate. OX 09 30	5 5	2 2	3 3	30 30	
						Inappropriate wax formulation specified	Industry standard MS-1633	Physical and Chemical Lab test - Report No. 1265 (5) Vehicle durability test T-118 (7)	50	None							
						Corner design prevents spray equip from reaching all areas		Design aid with non-functioning spray head (8) Vehicle durability test T-118 (7)	175	Team evaluation using production spray equipment and specified wax	T. Edwards Body Engineer and Assy Ops OX 11 15	Based on test: 3 additional vent holes provided in affected areas (error-proofed) OX 12 15	5	1	1	5	
						Insufficient room between panels for spray head access		Drawing evaluation of spray head access (4) Vehicle durability test T-118 (7)	80	Team evaluation using design aid buck and spray head	Body Engineer and Assy Ops OX 11 15	Evaluation showed adequate access OX 12 15	5	2	4	40	
a1	a2	b	c	d	e	f	h	g	i	j	k	l	m	n	o	p	q

Table III.1 Sample DFMEA Form with Minimal Information Elements & Example Entries

Potential Cause(s) of Failure Mode (f_2)

Potential cause of failure is defined as an indication of how the design process could allow the failure to occur, described in terms of something that can be corrected or can be controlled. Potential cause of failure may be an indication of a design weakness, the consequence of which is the failure mode.

Causes are the circumstances that induce or activate a failure mechanism.

In identifying potential causes of failure, use concise descriptions of the specific causes of failures, e.g., specified bolt plating allows for hydrogen embrittlement. Ambiguous phrases such as, poor design or improper design, should not be used.

Investigation of causes needs to focus on the failure mode and not on the effect(s). In determining the cause(s), the team should assume the existence of the cause under discussion will result in the failure mode (i.e., the failure mode does not require multiple causes to occur).

Typically, there may be several causes each of which can result in the failure mode. This results in multiple lines (cause branches) for the failure mode.

To the extent possible, list every potential cause for each failure mode/failure mechanism. The cause should be listed as concisely and completely as possible. Separating the causes will result in a focused analysis for each cause and may yield different measurement, controls, and action plans.

Table III.5. shows sample causes for the failure modes in Table III.3. Although not required as part of the minimum FMEA form elements, the table includes the failure mechanism to show the relationships among failure mode, failure mechanism, and cause.

In preparing the DFMEA, assume that the design will be manufactured and assembled to the design intent. Exceptions can be made at the team's discretion where historical data indicate deficiencies in the manufacturing process.

Failure Mode	Mechanism	Cause
Vehicle does not stop	No transfer of force from pedal to pads	Mechanical linkage break due to inadequate corrosion protection
		Master cylinder vacuum lock due to seal design
		Loss of hydraulic fluid from loose hydraulic line due to incorrect connector torque specification
		Loss of hydraulic fluid due to hydraulic lines crimped/compressed, inappropriate tube material specified
Vehicle stops in excess of yy feet	Reduced transfer of force from pedal to pads	Mechanical linkage joints stiff due to inappropriate lubrication specification
		Mechanical linkage joints corroded due to inadequate corrosion protection
		Partial loss of hydraulic fluid due to hydraulic lines crimped, inappropriate tube material specified
Stops vehicle with more than xx g's of force	Excessive/rapid transfer of force from pedal to pads	Cumulative pressure build-up in master cylinder due to seal design
Activate with no demand; Vehicle movement is impeded	Pads do not release	Corrosion or deposit build up on rails or pad ears due to surface finish not promoting adequate self cleaning and corrosion protection
Activate with no demand Vehicle cannot move	Hydraulic pressure does not release	Master cylinder vacuum lock due to seal design

Table III.5 Example Potential Causes

This page intentionally left blank.

POTENTIAL FAILURE MODE AND EFFECTS ANALYSIS (DESIGN FMEA)

FMEA Number: A of H Page F

Prepared By: F

FMEA Date (Orig.): _____

Design Responsibility: C

Key Date: _____

Design Responsibility: E

Key Date: _____

System: _____

Subsystem: _____

Component: B

Model Year(s)/Program(s): D

Core Team: G

Item / Function	Requirement	Potential Failure Mode	Potential Effect(s) of Failure	Severity	Classification	Potential Cause(s) of Failure	Current Design		RPN	Recommended Action	Responsibility & Target Completion Date	Action Results					
							Controls Prevention	Controls Detection				Completion Date	Severity	Occurrence	Detection	RPN	
Front Door, LH HBH-K-0000-A	Maintain integrity of inner door panel	Integrity breach allows environ. access of inner door panel	Corroded interior lower door panels Deteriorated life of door leading to: •Unsatisfactory appearance due to rust through paint over time. •Impaired function of interior door hardware	5		Upper edge of protective wax formulation for inner door panels is too low Insufficient wax thickness specified	Design requirements (#31268) and best practice (BP-3455) Design requirements (#31268) and best practice (BP-3455)	Vehicle durability test T-118 (7) Vehicle durability test T-118 (7)	105 105	Laboratory accelerated corrosion test Laboratory accelerated corrosion test	A. Tate Body Engineer OX 09 03 A. Tate Body Engineer OX 09 03	Based on test results (test no. 1481) upper edge spec raised 125 OX 09 30 Test results (Test No. 1481) show specified thickness is adequate. OX 09 30	5 5	2 2	3 3	30 30	
						Inappropriate wax formulation specified	Industry standard MS-1633	Physical and Chemical Lab test - Report No. 1265 (5) Vehicle durability test T-118 (7)	50	None							
		Corner design prevents spray equip from reaching all areas						Design aid with non-functioning spray head (8) Vehicle durability test T-118 (7)	175	Team evaluation using production spray equipment and specified wax	T. Edwards Body Engineer and Assy Ops OX 11 15	Based on test: 3 additional vent holes provided in affected areas (error-proofed) OX 12 15	5	1	1	5	
		Insufficient room between panels for spray head access						Drawing evaluation of spray head access (4) Vehicle durability test T-118 (7)	80	Team evaluation using design aid buck and spray head	Body Engineer and Assy Ops OX 11 15	Evaluation showed adequate access OX 12 15	5	2	4	40	
a1	a2	b	c	d	e	f	g	h	i	j	k	l	m	n	o	p	q

SAMPLE

Table III.1 Sample DFMEA Form with Minimal Information Elements & Example Entries

Occurrence (O) (g)

Occurrence is the likelihood that a specific cause/mechanism will occur resulting in the failure mode within the design life.

The likelihood of occurrence ranking number has a relative meaning rather than an absolute value (See Table Cr2).

A consistent occurrence ranking system should be used to ensure continuity. The occurrence number is a relative ranking within the scope of the FMEA and may not reflect the actual likelihood of occurrence.

Suggested Evaluation Criteria

The team should agree on evaluation criteria and a ranking system and apply them consistently, even if modified for individual process analysis. Occurrence should be estimated using a 1 to 10 scale using Table Cr2 as a guideline.

In determining this estimate, questions such as the following should be considered:

- What is the service history and field experience with similar components, subsystems, or systems?
- Is the item a carryover or similar to a previous level item?
- How significant are changes from a previous level item?
- Is the item radically different from a previous level item?
- Is the item completely new?
- What is the application or what are the environmental changes?
- Has an engineering analysis (e.g., reliability) been used to estimate the expected comparable occurrence rate for the application?
- Have preventive controls been put in place?

Likelihood of Failure	Criteria: Occurrence of Cause - DFMEA (Design life/reliability of item/vehicle)	Criteria: Occurrence of Cause - DFMEA (Incidents per items/vehicles)	Rank
Very High	New technology/new design with no history.	≥ 100 per thousand ≥ 1 in 10	10
High	Failure is inevitable with new design, new application, or change in duty cycle/operating conditions.	50 per thousand 1 in 20	9
	Failure is likely with new design, new application, or change in duty cycle/operating conditions.	20 per thousand 1 in 50	8
	Failure is uncertain with new design, new application, or change in duty cycle/operating conditions.	10 per thousand 1 in 100	7
Moderate	Frequent failures associated with similar designs or in design simulation and testing.	2 per thousand 1 in 500	6
	Occasional failures associated with similar designs or in design simulation and testing.	.5 per thousand 1 in 2,000	5
	Isolated failures associated with similar design or in design simulation and testing.	.1 per thousand 1 in 10,000	4
Low	Only isolated failures associated with almost identical design or in design simulation and testing.	.01 per thousand 1 in 100,000	3
	No observed failures associated with almost identical design or in design simulation and testing.	$\leq .001$ per thousand 1 in 1,000,000	2
Very Low	Failure is eliminated through preventive control.	Failure is eliminated through preventive control.	1

Table Cr2 Suggested DFMEA Occurrence Evaluation Criteria

This page intentionally left blank.

POTENTIAL FAILURE MODE AND EFFECTS ANALYSIS (DESIGN FMEA)

FMEA Number: A of pages

Page: H of pages

Prepared By: F

FMEA Date (Orig.):

Design Responsibility: C

Key Date: E

System:

Subsystem:

Component: B

Model Year(s)/Program(s): D

Core Team: G

Item / Function	Requirement	Potential Failure Mode	Potential Effect(s) of Failure	Severity	Classification	Potential Cause(s) of Failure	Current Design			Recommended Action	Responsibility & Target Completion Date	Action Results					
							Controls Prevention	Controls Detection	RPN			Actions Taken	Completion Date	Severity	Occurrence	Detection	RPN
Front Door, LH HBH-K-000-0-A	Maintain integrity of inner door panel	Integrity breach allows environ. access of inner door panel	Corroded interior lower door panels Deteriorated life of door leading to: • Unsatisfactory appearance due to rust through paint over time. • Impaired function of interior door hardware	5		Upper edge of protective wax formulation for inner door panels is too low Insufficient wax thickness specified	Design requirements (#31268) and best practice (BP-3455)	Vehicle durability test T-118 (7)	105	Laboratory accelerated corrosion test	A. Tate Body Engineer OX 09 03	Based on test results (test no. 1481) upper edge spec raised 125 OX 09 30	5	2	3	30	
						Inappropriate wax formulation specified	Industry standard MS-1633	Physical and Chemical Lab test - Report No. 1265 (5) Vehicle durability test T-118 (7)	50	None							
		Corner design prevents spray equip from reaching all areas						Design aid with non-functioning spray head (8) Vehicle durability test T-118 (7)	175	Team evaluation using production spray equipment and specified wax	T. Edwards Body Engineer and Assy Ops OX 11 15	Based on test: 3 additional vent holes provided in affected areas (error-proofed) OX 12 15	5	1	1	5	
		Insufficient room between panels for spray head access						Drawing evaluation of spray head access (4) Vehicle durability test T-118 (7)	80	Team evaluation using design aid buck and spray head	Body Engineer and Assy Ops OX 11 15	Evaluation showed adequate access OX 12 15	5	2	4	40	
a1	a2	b	c	d	e	f	h	g	h	i	j	k	l	m	n	o	p

Table III.1 Sample DFMEA Form with Minimal Information Elements & Example Entries

Current Design Controls (*h*)

Current Design Controls are those activities conducted as part of the design process that have been completed or committed to and that will assure the design adequacy for the design functional and reliability requirements under consideration.

There are two types of design controls to consider:

Prevention:

Eliminate (prevent) the cause of the mechanism of failure or the failure mode from occurring, or reduce its rate of occurrence.

Detection:

Identify (detect) the existence of a cause, the resulting mechanism of failure or the failure mode, either by analytical or physical methods, before the item is released for production.

The preferred approach is to first use prevention controls, if possible. The initial occurrence rankings will be affected by the prevention controls provided they are integrated as part of the design intent.

Detection control should include identification of those activities which detect the failure mode as well as those that detect the cause.

The team should consider analysis, testing, reviews, and other activities that will assure the design adequacy such as:

Prevention Controls

- Benchmarking studies
- Fail-safe designs
- Design and Material standards (internal and external)
- Documentation – records of best practices, lessons learned, etc. from similar designs
- Simulation studies – analysis of concepts to establish design requirements
- Error-proofing

Detection controls

- Design reviews
- Prototype testing
- Validation testing
- Simulation studies – validation of design
- Design of Experiments; including reliability testing
- Mock-up using similar parts

POTENTIAL FAILURE MODE AND EFFECTS ANALYSIS (DESIGN FMEA)

FMEA Number A of pages

Page H of

Prepared By: F

Design Responsibility C

Key Date E

FMEA Date (Orig.) F

System

Subsystem

Component B

Model Year(s)/Program(s) D

Core Team G

Potential Cause(s) of Failure

Potential Effect(s) of Failure

Potential Failure Mode

Requirement

Item

Item	Requirement	Potential Failure Mode	Potential Effect(s) of Failure	Severity	Classification	Potential Cause(s) of Failure	Current Design			Recommended Action	Responsibility & Target Completion Date	Action Results				
							Controls Prevention	Controls Detection	RPN			Actions Taken	Completion Date	Severity	Occurrence	Detection
Front Door, LH HBH-K-000-0-A	Maintain integrity of inner door panel	Integrity breach allows environ. access of inner door panel	Corroded interior lower door panels Deteriorated life of door leading to: •Unsatisfactory appearance due to rust through paint over time. •Impaired function of interior door hardware	5		Upper edge of protective wax formulation for inner door panels is too low Insufficient wax thickness specified	Design requirements (#31268) and best practice (BP 3455)	Vehicle durability test T-118 (7)	105	Laboratory accelerated corrosion test	A. Tate Body Engineer OX 09 03	Based on test results (test no. 1481) upper edge spec raised 125 OX 09 30	5	2	3	30
						Inappropriate wax formulation specified	Industry standard MS-1633	Physical and Chemical Lab test - Report No. 1265 (5) Vehicle durability test T-118 (7)	50	None	A. Tate Body Engineer OX 09 03	Test results (Test No. 1481) show specified thickness is adequate. OX 09 30	5	2	3	30
						Corner design prevents spray equip from reaching all areas		Design aid with non-functioning spray head (8) Vehicle durability test T-118 (7)	175	Team evaluation using production spray equipment and specified wax	T. Edwards Body Engineer and Assy Ops OX 11 15	Based on test: 3 additional vent holes provided in affected areas (error-proofed) OX 12 15	5	1	1	5
						Insufficient room between panels for spray head access		Drawing evaluation of spray head access (4) Vehicle durability test T-118 (7)	80	Team evaluation using design aid buck and spray head	Body Engineer and Assy Ops OX 11 15	Evaluation showed adequate access OX 12 15	5	2	4	40
a1	a2	b	c	d	e	f	h	g	ij	k	l	m	n	o	p	q

Table III.1 Sample DFMEA Form with Minimal Information Elements & Example Entries

The example Design FMEA form in this manual has two columns for the design controls (i.e., separate columns for Prevention Controls and Detection Controls) to assist the team in clearly distinguishing between these two types of design controls. This allows for a quick visual determination that both types of design controls have been considered.

If a one-column (for design controls) form is used, then the following prefixes should be used. For prevention controls, place a 'P' before each prevention control listed. For detection controls, place a 'D' before each detection control listed.

Preventing the causes of the failure mode through a design change or design process change is the only way a reduction in the occurrence ranking can be effected.

Table III.6 shows example prevention and detection controls for the causes identified in Table III.5.

Failure Mode	Cause	Prevention controls	Detection controls
Vehicle does not stop	Mechanical linkage break due to inadequate corrosion protection	Designed per material standard MS-845	Environmental stress test 03-9963
	Master cylinder vacuum lock due to seal design	Carry-over design with same duty cycle requirements	Pressure variability testing – system level
	Loss of hydraulic fluid from loose hydraulic line due to incorrect connector torque specification	Designed per torque requirements - 3993	Vibration step-stress test 18-1950
	Loss of hydraulic fluid due to hydraulic lines crimped/compressed, inappropriate tube material specified	Designed per material standard MS-1178	Design of Experiments (DOE) – tube resiliency

Table III.6 Examples of Prevention and Detection Design Controls

POTENTIAL FAILURE MODE AND EFFECTS ANALYSIS (DESIGN FMEA)

FMEA Number A of
 Page H of
 Prepared By: F
 FMEA Date (Orig.)

Design Responsibility C
 Key Date E

System B
 Subsystem D
 Component G
 Model Year(s)/Program(s)
 Core Team

Item / Function	Requirement	Potential Failure Mode	Potential Effect(s) of Failure	Severity	Classification	Potential Cause(s) of Failure	Current Design			Recommended Action	Responsibility & Target Completion Date	Action Results					
							Controls Prevention	Controls Detection	RPN			Actions Taken	Completion Date	Severity	Occurrence	Detection	RPN
Front Door, LH HBH-K-000-0-A	Maintain integrity of inner door panel	Integrity breach allows environ. access of inner door panel	Corroded interior lower door panels Deteriorated life of door leading to: •Unsatisfactory appearance due to rust through paint over time. •Impaired function of interior door hardware	5		Upper edge of protective wax formulation for inner door panels is too low Insufficient wax thickness specified	Design requirements (#31268) and best practice (BP-3455)	Vehicle durability test T-118 (7)	105	Laboratory accelerated corrosion test	A. Tate Body Engineer OX 09 03	Based on test results (test no. 1481) upper edge spec raised 125 OX 09 30	5	2	3	30	
						Inappropriate wax formulation specified	Industry standard MS-1633	Physical and Chemical Lab test - Report No. 1265 (5) Vehicle durability test T-118 (7)	50	None							
						Corner design prevents spray equip from reaching all areas		Design aid with non-functioning spray head (8) Vehicle durability test T-118 (7)	175	Team evaluation using production spray equipment and specified wax	T. Edwards Body Engineer and Assy Ops OX 11 15	Based on test: 3 additional vent holes provided in affected areas (error-proofed) OX 12 15	5	1	1	5	
						Insufficient room between panels for spray head access		Drawing evaluation of spray head access (4) Vehicle durability test T-118 (7)	80	Team evaluation using design aid buck and spray head	Body Engineer and Assy Ops OX 11 15	Evaluation showed adequate access OX 12 15	5	2	4	40	
a1	a2	b	c	d	e	f	h	g	i	j	k	l	m	n	o	p	q

Table III.1 Sample DFMEA Form with Minimal Information Elements & Example Entries

Detection (D) (i)

Detection is the rank associated with the best detection control listed in the Current Design Control Detection column. When more than one control is identified, it is recommended that the detection ranking of each control be included as part of the description of the control. Record the lowest ranking value in the Detection column.

A suggested approach to Current Design Control Detection is to assume the failure has occurred and then assess the capabilities of the current design controls to detect this failure mode.

Do not automatically presume that the detection ranking is low because the occurrence is low. It is important to assess the capability of the design controls to detect low frequency failure modes or reduce the risk of them going further in the design release process.

Detection is a relative ranking within the scope of the individual FMEA. In order to achieve a lower ranking, generally the design control (analysis or verification activities) has to be improved.

Suggested Evaluation Criteria

The team should agree on evaluation criteria and a ranking system and apply them consistently, even if modified for individual process analysis. Detection should be estimated using Table Cr3 as a guideline.

The ranking value of one (1) is reserved for failure prevention through proven design solutions.

Opportunity for Detection	Criteria: Likelihood of Detection by Design Control	Rank	Likelihood of Detection
No detection opportunity	No current design control; Cannot detect or is not analyzed.	10	Almost Impossible
Not likely to detect at any stage	Design analysis/detection controls have a weak detection capability; Virtual Analysis (e.g., CAE, FEA, etc.) is not correlated to expected actual operating conditions.	9	Very Remote
Post Design Freeze and prior to launch	Product verification/validation after design freeze and prior to launch with pass/fail testing (Subsystem or system testing with acceptance criteria such as ride and handling, shipping evaluation, etc.).	8	Remote
	Product verification/validation after design freeze and prior to launch with test to failure testing (Subsystem or system testing until failure occurs, testing of system interactions, etc.).	7	Very Low
	Product verification/validation after design freeze and prior to launch with degradation testing (Subsystem or system testing after durability test, e.g., function check).	6	Low
Prior to Design Freeze	Product validation (reliability testing, development or validation tests) prior to design freeze using pass/fail testing (e.g., acceptance criteria for performance, function checks, etc.).	5	Moderate
	Product validation (reliability testing, development or validation tests) prior to design freeze using test to failure (e.g., until leaks, yields, cracks, etc.).	4	Moderately High
	Product validation (reliability testing, development or validation tests) prior to design freeze using degradation testing (e.g., data trends, before/after values, etc.).	3	High
Virtual Analysis - Correlated	Design analysis/detection controls have a strong detection capability. Virtual analysis (e.g., CAE, FEA, etc.) is highly correlated with actual or expected operating conditions prior to design freeze.	2	Very High
Detection not applicable; Failure Prevention	Failure cause or failure mode can not occur because it is fully prevented through design solutions (e.g., proven design standard, best practice or common material, etc.).	1	Almost Certain

Table Cr3 Suggested DFMEA/PFMEA Prevention/Detection Evaluation Criteria

This page intentionally left blank.

POTENTIAL FAILURE MODE AND EFFECTS ANALYSIS (DESIGN FMEA)

System _____ FMEA Number A

Subsystem _____ Page _____ of _____

Component B Prepared By: H

Model Year(s)/Program(s) D Design Responsibility C

G Key Date _____ FMEA Date (Orig.) F

Core Team _____

Item / Function	Requirement	Potential Failure Mode	Potential Effect(s) of Failure	Severity	Classification	Potential Cause(s) of Failure	Current Design			Recommended Action	Responsibility & Target Completion Date	Action Results					
							Controls Prevention	Controls Detection	RPN			Actions Taken	Completion Date	Severity	Occurrence	Detection	RPN
Front Door, LH HBH-K-000-0-A	Maintain integrity of inner door panel	Integrity breach allows environ. access of inner door panel	Corroded interior lower door panels Deteriorated life of door leading to: • Unsatisfactory appearance due to rust through paint over time. • Impaired function of interior door hardware	5		Upper edge of protective wax formulation for inner door panels is too low Insufficient wax thickness specified	Design requirements (#31268) and best practice (BP-3455)	Vehicle durability test T-118 (7)	7	105	Laboratory accelerated corrosion test	A. Tate Body Engineer OX 09 03	Based on test results (test no. 1481) upper edge spec raised 125 OX 09 30	5	2	3	30
						Inappropriate wax formulation specified	Industry standard MS-1633	Physical and Chemical Lab test - Report No. 1265 (5) Vehicle durability test T-118 (7)	5	50	None	A. Tate Body Engineer OX 09 03	Test results (Test No. 1481) show specified thickness is adequate. OX 09 30	5	2	3	30
						Corner design prevents spray equip from reaching all areas		Design aid with non-functioning spray head (8) Vehicle durability test T-118 (7)	7	175	Team evaluation using production spray equipment and specified wax	T. Edwards Body Engineer and Assy Ops OX 11 15	Based on test: 3 additional vent holes provided in affected areas (error-proofed) OX 12 15	5	1	1	5
						Insufficient room between panels for spray head access		Drawing evaluation of spray head access (4) Vehicle durability test T-118 (7)	4	80	Team evaluation using design aid buck and spray head	Body Engineer and Assy Ops OX 11 15	Evaluation showed adequate access OX 12 15	5	2	4	40
a1	a2	b	c	d	e	f	h	g	h	i	j	k	l	m	n	o	p

SAMPLE

Table III.1 Sample DFMEA Form with Minimal Information Elements & Example Entries

Determining Action Priorities

Once the team has completed the initial identification of failure modes and effects, causes and controls, including rankings for severity, occurrence, and detection, they must decide if further efforts are needed to reduce the risk. Due to the inherent limitations on resources, time, technology, and other factors, they must choose how to best prioritize these efforts.

The initial focus of the team should be oriented towards failure modes with the highest severity rankings. When the severity is 9 or 10, it is imperative that the team must ensure that the risk is addressed through existing design controls or recommended actions (as documented in the FMEA).

For failure modes with severities 8 or below the team should consider causes having highest occurrence or detection rankings. It is the team's responsibility to look at the information identified, decide upon an approach, and determine how to best prioritize the risk reduction efforts that best serve their organization and customers.

Risk Evaluation; Risk Priority Number (RPN) (j)

One approach to assist in action prioritization has been to use the Risk Priority Number:

$$\text{RPN} = \text{Severity (S)} \times \text{Occurrence (O)} \times \text{Detection (D)}$$

Within the scope of the individual FMEA, this value can range between 1 and 1000.

*The use of an RPN threshold is **NOT** a recommended practice for determining the need for actions.*

Applying thresholds assumes that RPNs are a measure of relative risk (which they often are not) and that continuous improvement is not required (which it is).

For example, if the customer applied an arbitrary threshold of 100 to the following, the supplier would be required to take action on the characteristic B with the RPN of 112.

Item	Severity	Occurrence	Detection	RPN
A	9	2	5	90
B	7	4	4	112

POTENTIAL FAILURE MODE AND EFFECTS ANALYSIS (DESIGN FMEA)

FMEA Number: A of pages

Page: H of pages

Prepared By: F

FMEA Date (Orig.):

Design Responsibility: C

Key Date: E

System:

Subsystem:

Component: B

Model Year(s)/Program(s): D

Core Team: G

Item / Function	Requirement	Potential Failure Mode	Potential Effect(s) of Failure	Severity	Classification	Potential Cause(s) of Failure	Current Design		RPN	Recommended Action	Responsibility & Target Completion Date	Action Results				
							Controls Prevention	Controls Detection				Completion Date	Severity	Occurrence	Detection	RPN
Front Door, LH HBH-K-000-0-A	Maintain integrity of inner door panel	Integrity breach allows environ. access of inner door panel	Corroded interior lower door panels Deteriorated life of door leading to: •Unsatisfactory appearance due to rust through paint over time. •Impaired function of interior door hardware	5		Upper edge of protective wax formulation for inner door panels is too low Insufficient wax thickness specified	Design requirements (#31268) and best practice (BP-3455)	Vehicle durability test T-118 (7)	105	Laboratory accelerated corrosion test	A. Tate Body Engineer OX 09 03	Based on test results (test no. 1481) upper edge spec raised 125 OX 09 30	5	2	3	30
						Inappropriate wax formulation specified	Design requirements (#31268) and best practice (BP-3455)	Vehicle durability test T-118 (7)	105	Laboratory accelerated corrosion test	A. Tate Body Engineer OX 09 03	Test results (Test No. 1481) show specified thickness is adequate. OX 09 30	5	2	3	30
						Inappropriate wax formulation specified	Industry standard MS-1633	Physical and Chemical Lab test - Report No. 1265 (5) Vehicle durability test T-118 (7)	50	None	J. Smythe Body Engineer OX 10 18	DOE shows 25% variation in specified thickness is acceptable OX 10 25				
						Corner design prevents spray equip from reaching all areas		Design aid with non-functioning spray head (8) Vehicle durability test T-118 (7)	175	Team evaluation using production spray equipment and specified wax	T. Edwards Body Engineer and Assy Ops OX 11 15	Based on test: 3 additional vent holes provided in affected areas (error-proofed) OX 12 15	5	1	1	5
						Insufficient room between panels for spray head access		Drawing evaluation of spray head access (4) Vehicle durability test T-118 (7)	80	Team evaluation using design aid buck and spray head	Body Engineer and Assy Ops OX 11 15	Evaluation showed adequate access OX 12 15	5	2	4	40
a1	a2	b	c	d	e	f	g	h	i	j	k	l	m	n	o	p

SAMPLE

Table III.1 Sample DFMEA Form with Minimal Information Elements & Example Entries

In this example, the RPN is higher for characteristic B, but the priority should be to work on A with the higher severity of 9, although the RPN is 90 which is lower and below the threshold.

Another concern with using the threshold approach is that there is no specific RPN value that requires mandatory action.

Unfortunately, establishing such thresholds may promote the wrong behavior causing team members to spend time trying to justify a lower occurrence or detection ranking value to reduce RPN. This type of behavior avoids addressing the real problem that underlies the cause of the failure mode and merely keeps the RPN below the threshold. It is important to recognize that while determining “acceptable” risk at a particular program milestone (e.g., vehicle launch) is desirable, it should be based on an analysis of severity, occurrence and detection and not through the application of RPN thresholds.

Use of the RPN index in the discussions of the team can be a useful tool. The limitations of the use of RPN need to be understood. However, the use of RPN thresholds to determine action priority is not recommended.

Recommended Action(s) (*k*)

In general, prevention actions (i.e., reducing the occurrence) are preferable to detection actions. An example of this is the use of proven design standard or best practice rather than product verification/validation after design freeze.

The intent of recommended actions is to improve the design. Identifying these actions should consider reducing rankings in the following order: severity, occurrence, and detection. Example approaches to reduce these are explained below:

- **To Reduce Severity (*S*) Ranking:** Only a design revision can bring about a reduction in the severity ranking.

High severity rankings can sometimes be reduced by making design revisions that compensate or mitigate the resultant severity of failure. For example: The requirement for a tire is to “retain applied air pressure under use”. The severity of the effect of the failure mode “rapid loss of air pressure” would be lower for a “run flat” tire.

A design change, in and of itself, does not imply that the severity will be reduced. Any design change should be reviewed by the team to determine the effect to the product functionality and process.

POTENTIAL FAILURE MODE AND EFFECTS ANALYSIS (DESIGN FMEA)

System _____ FMEA Number A

Subsystem _____ Page _____ of _____

Component B Prepared By: H

Model Year(s)/Program(s) D Design Responsibility C

G Key Date _____ FMEA Date (Orig.) F

Core Team _____

Item / Function	Requirement	Potential Failure Mode	Potential Effect(s) of Failure	Severity	Classification	Potential Cause(s) of Failure	Current Design			Recommended Action	Responsibility & Target Completion Date	Action Results				
							Controls Prevention	Controls Detection	RPN			Actions Taken	Completion Date	Severity	Occurrence	Detection
Front Door, LH HBH-K-000-0-A	Maintain integrity of inner door panel	Integrity breach allows environ. access of inner door panel	Corroded interior lower door panels Deteriorated life of door leading to: • Unsatisfactory appearance due to rust through paint over time. • Impaired function of interior door hardware	5		Upper edge of protective wax formulation for inner door panels is too low Insufficient wax thickness specified	Design requirements (#31268) and best practice (BP 3455)	Vehicle durability test T-118 (7)	105	Laboratory accelerated corrosion test	A. Tate Body Engineer OX 09 03	Based on test results (test no. 1481) upper edge spec raised 125 OX 09 30	5	2	3	30
						Inappropriate wax formulation specified	Industry standard MS-1633	Physical and Chemical Lab test - Report No. 1265 (5) Vehicle durability test T-118 (7)	50	None	A. Tate Body Engineer OX 09 03	Test results (Test No. 1481) show specified thickness is adequate. OX 09 30	5	2	3	30
						Corner design prevents spray equip from reaching all areas		Design aid with non-functioning spray head (8) Vehicle durability test T-118 (7)	175	Team evaluation using production spray equipment and specified wax	T. Edwards Body Engineer and Assy Ops OX 11 15	Based on test: 3 additional vent holes provided in affected areas (error-proofed) OX 12 15	5	1	1	5
						Insufficient room between panels for spray head access		Drawing evaluation of spray head access (4) Vehicle durability test T-118 (7)	80	Team evaluation using design aid buck and spray head	Body Engineer and Assy Ops OX 11 15	Evaluation showed adequate access OX 12 15	5	2	4	40
a1	a2	b	c	d	e	f	h	g	i	j	k	m	n	o	p	q

Table III.1 Sample DFMEA Form with Minimal Information Elements & Example Entries

For maximum effectiveness and efficiency of this approach, changes to the product and process design should be implemented early in the development process. For example, alternate materials may need to be considered early in the development cycle to eliminate corrosion severity.

- ***To Reduce Occurrence (O) Ranking:*** A reduction in the occurrence ranking can be effected by removing or controlling one or more of the causes or mechanisms of the failure mode through a design revision. Actions such as, but not limited to, the following should be considered:
 - Error proof the design to eliminate the failure mode
 - Revised design geometry and tolerances
 - Revised design to lower the stresses or replace weak (high failure probability) components
 - Add redundancy
 - Revised material specification
- ***To Reduce Detection (D) Ranking:*** The preferred method is the use of error/mistake proofing. An increase in design validation/verification actions should result in a reduction of the detection ranking only. In some cases, a design change to a specific part may be required to increase the likelihood of detection (i.e., reduce the detection ranking). Additionally, the following should be considered:
 - Design of Experiments (particularly when multiple or interactive causes of a failure mode are present)
 - Revised test plan

If the assessment leads to no recommended actions for a specific failure mode/cause/control combination, indicate this by entering “None” in this column. It may be useful to also include a rationale if “None” is entered, especially in case of high severity.

For design actions consider using the following:

- Results of design DOE or reliability testing
- Design analysis (reliability, structural or physics of failure) that would confirm that the solution is effective and does not introduce new potential failure modes
- Drawing, schematics, or model to confirm physical change of targeted feature
- Results from a design review
- Changes to a given Engineering Standard or Design Guidelines
- Reliability analysis results

POTENTIAL FAILURE MODE AND EFFECTS ANALYSIS (DESIGN FMEA)

System _____ FMEA Number **A**

Subsystem _____ Page _____ of _____

Component **B** Design Responsibility **C** Prepared By: **H**

Model Year(s)/Program(s) **D** Key Date _____ FMEA Date (Orig.) **F**

Core Team **G**

Item Function	Requirement	Potential Failure Mode	Potential Effect(s) of Failure	Severity	Classification	Potential Cause(s) of Failure	Current Design			RPN	Recommended Action	Responsibility & Target Completion Date	Action Results				
							Controls Prevention	Controls Detection	Detection				Actions Taken	Completion Date	Severity	Occurrence	Detection
Front Door, LH HBH-K-000-0-A	Maintain integrity of inner door panel	Integrity breach allows environ. access of inner door panel	Corroded interior lower door panels Deteriorated life of door leading to: • Unsatisfactory appearance due to rust through paint over time. • Impaired function of interior door hardware	5		Upper edge of protective wax formulation specified for inner door panels is too low Insufficient wax thickness specified	Design requirements (#31268) and best practice (BP 3455)	Vehicle durability test. T-118 (7)	7	105	Laboratory accelerated corrosion test	A. Tate Body Engineer OX 09 03	Based on test results (test no. 1481) upper edge spec raised 125 OX 09 30	5	2	3	30
						Inappropriate wax formulation specified	Industry standard MS-1633	Physical and Chemical Lab test - Report No. 1265 (5) Vehicle durability test. T-118 (7)	5	50	None	J. Smythe Body Engineer OX 10 18	DOE shows 25% variation in specified thickness is acceptable OX 10 25	5	2	3	30
						Corner design prevents spray equip from reaching all areas		Design aid with non-functioning spray head (8) Vehicle durability test. T-118 (7)	7	175	Team evaluation using production spray equipment and specified wax	T. Edwards Body Engineer and Assy Ops OX 11 15	Based on test: 3 additional vent holes provided in affected areas (error-proofed) OX 12 15	5	1	1	5
						Insufficient room between panels for spray head access		Drawing of spray head access (4) Vehicle durability test. T-118 (7)	4	80	Team evaluation using design aid buck and spray head	Body Engineer and Assy Ops OX 11 15	Evaluation showed adequate access OX 12 15	5	2	4	40
a1	a2	b	c	d	e	f	h	g	i	j	k	l	m	n	o	p	q

Table III.1 Sample DFMEA Form with Minimal Information Elements & Example Entries

Table III.7 below provides an example of the application of causes (Column f), controls (Column h) and recommended actions (Column k).

Responsibility & Target Completion Date (*l*)

Enter the name of the individual and organization responsible for completing each recommended action including the target completion date. The design-responsible engineer/team leader is responsible for ensuring that all actions recommended have been implemented or adequately addressed.

Action Results (*m-n*)

This section identifies the results of any completed actions and their effect on S, O, D rankings and RPN.

Action(s) Taken and Completion Date (*m*)

After the action has been implemented, enter a brief description of the action taken and actual completion date.

Severity, Occurrence, Detection and RPN (*n*)

After the preventive/corrective action has been completed, determine and record the resulting severity, occurrence, and detection rankings.

Calculate and record the resulting action (risk) priority indicator (e.g., RPN).

All revised rankings should be reviewed. Actions alone do not guarantee that the problem was solved (i.e., cause addressed), thus an appropriate analysis or test should be completed as verification. If further action is considered necessary, repeat the analysis. The focus should always be on continuous improvement.

Item	Failure Mode	Cause	Prevention Controls	Detection Controls	Recommended Actions
Disk Brake system	Vehicle does not stop	Mechanical linkage break due to inadequate corrosion protection	Designed per material standard MS-845	Environmental stress test 03-9963	Change material to stainless steel
		Master cylinder vacuum lock due to seal design	Carry-over design with same duty cycle requirements	Pressure variability testing – system level	Use carry-over seal design
		Loss of hydraulic fluid from loose hydraulic line due to incorrect connector torque specification	Designed per torque requirements - 3993	Vibration step-stress test 18-1950	Modify connector from bolt-style to quick-connect
		Loss of hydraulic fluid due to hydraulic lines crimped/compressed, inappropriate tube material specified	Designed per material standard MS-1178	DOE – tube resiliency	Modify hose design from MS-1178 to MS-2025 to increase strength

Table III.7 Examples of Causes, Controls and Recommended Actions

Maintaining DFMEAs

The DFMEA is a living document and should be reviewed whenever there is a product design change and updated, as required. Recommended actions updates should be included into a subsequent DFMEA along with the final results (what worked and what did not work).

Another element of on-going maintenance of DFMEAs should include a periodic review of the rankings used in the DFMEA. Specific focus should be given to Occurrence and Detection rankings. This is particularly important where improvements have been made either through product changes or improvements in design controls. Additionally, in cases where field issues have occurred, the rankings should be revised accordingly.

Leveraging DFMEAs

If a new project or application is functionally similar to the existing product, a single DFMEA may be used with customer concurrence. Using a fundamentally sound baseline DFMEA as the starting point provides the greatest opportunity to leverage past experience and knowledge. If there are slight differences, the team should identify and focus on the effects of these differences.

Linkages

The DFMEA is not a “stand-alone” document. For example, the output of the DFMEA can be used as input for subsequent product development processes. It is the summary of the team’s discussions and analysis. Figure III.7 shows the linkages of some of the commonly used documents.

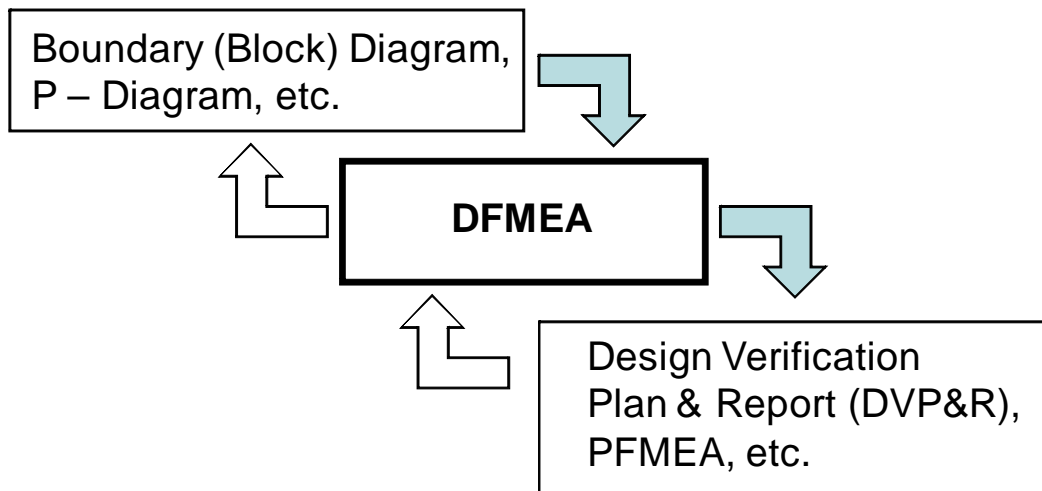

Figure III.7 DFMEA Information Interrelationships Flow

Design Verification Plan & Report (DVP&R)

DFMEA and DVP&R have an important linkage. The DFMEA identifies and documents the current design prevention and detection controls which become input to the test description included within the DVP&R. The DFMEA identifies “what” the controls are while the DVP&R provides the “how” such as acceptance criteria, procedure and sample size.

PFMEA

Another important linkage is between the DFMEA and PFMEA. For example, a Process (PFMEA) failure mode or a Design (DFMEA) failure mode can result in the same potential product effect. In this case, the effects of the design failure mode should be reflected in the effects and severity rankings of the DFMEA and PFMEA.

Chapter IV

PFMEA

Process Failure Mode and Effects Analysis

Introduction

The process FMEA, referred to as PFMEA, supports manufacturing process development in reducing the risk of failures by:

- Identifying and evaluating the process functions and requirements,
- Identifying and evaluating potential product and process-related failure modes, and the effects of the potential failures on the process and customers,
- Identifying the potential manufacturing or assembly process causes,
- Identifying process variables on which to focus process controls for occurrence reduction or increased detection of the failure conditions, and
- Enabling the establishment of a priority system for preventive/corrective action and controls.

The PFMEA is a living document and should:

- Be initiated before or at the feasibility stage,
- Be initiated prior to tooling for production,
- Take into account all manufacturing operations from individual components to assemblies, and
- Include all processes within the plant that can impact the manufacturing and assembly operations, such as shipping, receiving, transporting of material, storage, conveyors or labeling.

Early review and analysis of new or revised processes is advised to anticipate, resolve, or monitor potential process concerns during the manufacturing planning stages of a new model or component program.

The PFMEA assumes the product as designed will meet the design intent. Potential failure modes that can occur because of a design weakness may be included in a PFMEA. Their effect and avoidance is covered by the Design FMEA.

The PFMEA does not rely on product design changes to overcome limitations in the process. However, it does take into consideration a product's design characteristics relative to the planned manufacturing or assembly process to assure that, to the extent possible, the resultant product meets customer needs and expectations. For example, the PFMEA development generally assumes that the machines and equipment will meet their design intent and therefore are excluded from the scope. Control mechanisms for incoming parts and materials may need to be considered based on historical data.

Customer Defined

The definition of “Customer” for a PFMEA should normally be the “End User.” However, the customer can also be a subsequent or downstream manufacturing or assembly operation, a service operation, or regulator.⁵

Team Approach

The PFMEA is developed and maintained by a multi-disciplinary (or cross-functional) team typically led by the responsible engineer. During the initial development of the PFMEA, the responsible engineer/team leader is expected to directly and actively involve representatives from all affected areas. These areas should include but are not limited to design, assembly, manufacturing, materials, quality, service, and suppliers, as well as the area responsible for the next assembly. The PFMEA should be a catalyst to stimulate the interchange of ideas between the areas affected and thus promote a team approach.

Design Considerations

The team should assume the product as designed will meet the design intent.

During the development of a PFMEA, the team may identify design opportunities which, if implemented, would either eliminate or reduce the occurrence of a process failure mode. For example, adding a feature to a part and a matching feature to a fixture will eliminate the possibility of an operator placing a part in the wrong orientation. Such information must be provided to the responsible design engineer as well as the tooling / equipment / fixture design-responsible individual for consideration and possible implementation.

⁵ See discussion in Chapter II, Customer Defined

Development of a Process FMEA

The process-responsible engineer/team leader has at his or her disposal a number of documents that will be useful in preparing the PFMEA. The PFMEA begins by developing a list of what the process is expected to do and what it is expected not to do, i.e., the process intent.

The PFMEA should begin with a flow chart of the general process. This flow chart should identify the product/process characteristics associated with each operation. Identification of product effects from the corresponding DFMEA should be included. Copies of the flow chart used in the PFMEA preparation should accompany it.

In order to facilitate documentation of the analysis of potential failures and their consequences, example PFMEA forms have been developed and are provided in Appendix A. The minimum information content required for a PFMEA is discussed below. (Also see Table IV.1)

Prerequisites

A PFMEA should begin with the development of information to understand the manufacturing and assembly operations being analyzed and define their requirements.

The process flow diagram is a primary input to the PFMEA. The flow diagram is used as a tool to help establish the scope of analysis during manufacturing system design.

Process Flow Diagram and linkage to PFMEA

A process flow diagram⁶ describes the flow of the product through the process – from incoming to outgoing. This should include each step in a manufacturing or assembly process as well as their related outputs (product characteristics, requirements, deliverables, etc.) and inputs (process characteristics, sources of variation, etc.). The detail of the process flow depends on the stage of process development discussion. The initial flow diagram is generally considered a high level process map. It needs more detailed analysis to identify the potential failure modes.

⁶ The Process Flow Diagram is also referred to as a Process Flow Chart.

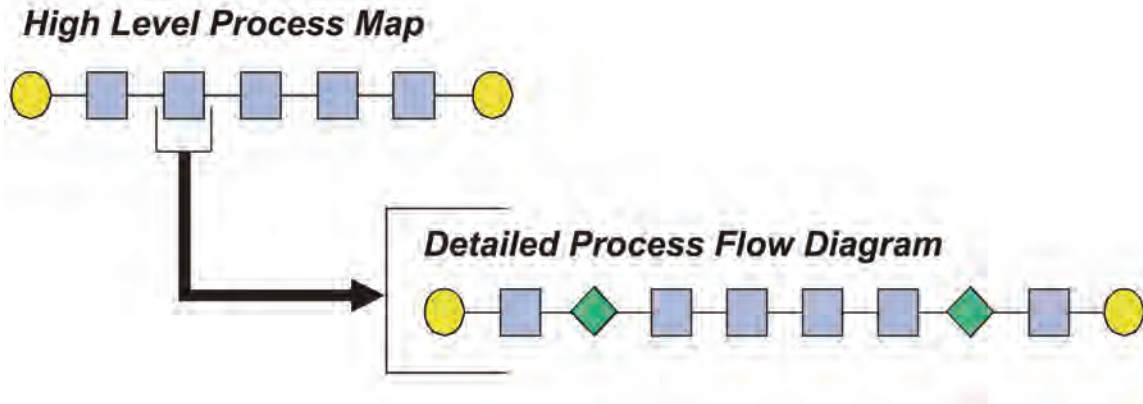

Figure IV.1 High Level to Detailed Process Maps

The PFMEA should be consistent with the information in the process flow diagram. The scope of the process flow diagram should include all manufacturing operations from processing of individual components to assemblies including shipping, receiving, transportation of material, storage, conveyors, labeling, etc. A preliminary risk assessment using the process flow diagram may be performed to identify which of these operations or individual steps can have an impact on the product manufacturing and assembly and should be included in the PFMEA.

The PFMEA development continues by identifying the requirement(s) for each process/function. Requirements are the outputs of each operation/step and relate to the requirements for the product. The Requirements provide a description of what should be achieved at each operation/step. The Requirements provide the team with a basis to identify potential failure modes.

In order to assure continuity, it is highly recommended that the same cross-functional team develop the Process Flow Diagram, PFMEA, and Control Plan.

See Figure IV.2 for an example process flow diagram.

Department: XXXXXXXXXX

Page 1 of 2

Prod/Svc: Belt Drive Component

ID Number: XXXXXXXXXX

Date: 09/24/08

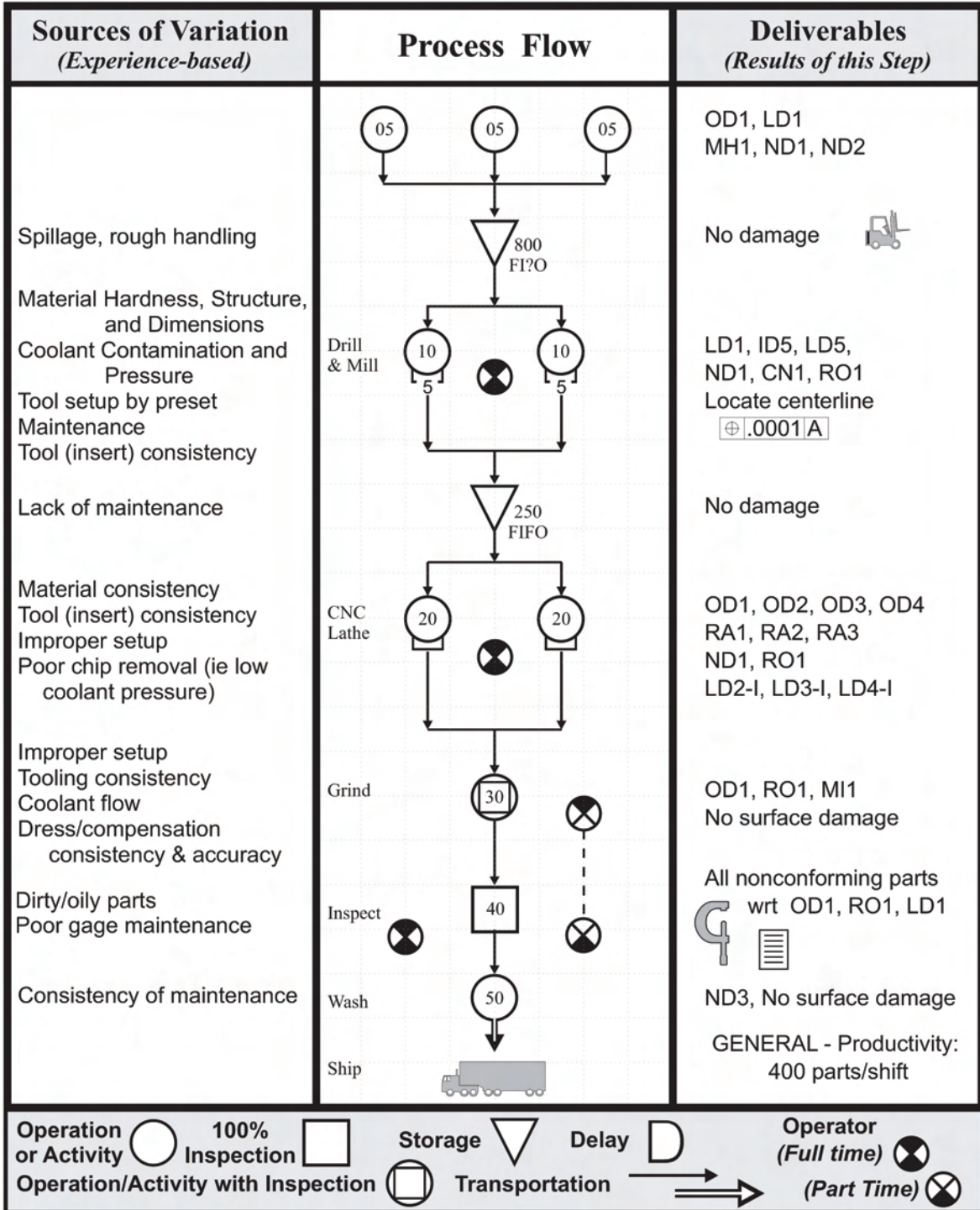

© 1985-1993 THE THIRD GENERATION, INC.

Figure IV.2 Example Process Flow Diagram

Other Tools and Information Sources

Other sources of information that are useful in providing the team with ways to focus and capture discussions on the requirements of the process include:

- DFMEA
- Drawings and design records
- Bill of Process
- Interrelationship (Characteristic) matrix
- Internal and external (customer) nonconformances (i.e., known failure modes based on historical data)
- Quality and Reliability History

Research Information

After establishing the scope of the analysis effort, the team should begin by reviewing historical information. The areas to review should include:

- Lessons that have been learned from previous product and process design implementation, and
- Any information available that establishes best practices including items such as guidelines and standards, standard part identification, or error-proofing methods.

Quality performance information available from similar, previous product and process designs, including items such as: process yield⁷, first time capability (both end of line and at each operation), Parts per Million (PPM), process capability indices (C_{pk} and P_{pk}), and warranty metrics.

The information can be useful input for determination of severity, occurrence and detection rankings.

After considering these prerequisites, start filling out the form (Table IV.1 below).

⁷ First Time Quality (FTQ); First Time Through (FTT)

FMEA Number A
 Page of
 Prepared By: H
 FMEA Date (Orig.) F

POTENTIAL FAILURE MODE AND EFFECTS ANALYSIS (PROCESS FMEA)
 Process Responsibility C
 Key Date E

Item: B
 Model Year(s)/Program(s) D
 Core Team G

Process Step / Function	Requirement	Potential Failure Mode	Potential Effect(s) of Failure	Severity	Classification	Potential Cause(s) of Failure	Current Process			Recommended Action	Responsibility & Target Completion Date	Action Results					
							Controls Prevention	Controls Detection	RPN			Actions Taken	Completion Date	Severity	Occurrence	Detection	RPN
Op 70: Manual application of wax inside door panel	Cover inner door, lower surfaces with wax to specification thickness	Insufficient wax coverage over specified surface	Allows integrity breach of inner door panel Corroded interior lower door panels Deteriorated life of door leading to: • Unsatisfactory appearance due to rust through paint over time. • Impaired function of interior door hardware	7		Manually inserted spray head not inserted far enough	None	8	Variables check for film thickness Visual check for coverage.	280	Mfg Engineering by DX 10 15	Stop added, sprayer checked online	7	2	5	70	
			Spray head clogged - Viscosity too high - Temperature too low - Pressure too low			Test spray at start-up and after life periods and preventative maintenance program to clean heads	5	Variables check for film thickness Visual check for coverage.	175	Mfg Engineering by DX 10 01	Rejected due to complexity of different doors on the same line	Temp and Press Limits were determined and limit controls have been installed. Control charts show process is in control Cpk=1.85	7	1	5	35	
			Spray head deformed due to impact			Preventative maintenance programs to maintain heads	2	Variables check for film thickness Visual check for coverage.	70	None							
			Spray time sufficient			None	5	Operator instructions (visual) check coverage of critical areas	245	Maintenance XXX/XX/XX	Automatic spray timer installed- operator starts spray, timer controls shut-off control charts show process is in control - Cpk=2.05	7	1	7	49		
a1	a2	b	c	d	e	f	h	g	i	j	k	l	m	n	o	p	
		Excessive wax coverage over specified surface															

Table IV.1 Sample PFMEA Form with Minimal Information Elements & Example Entries

Example PFMEA Form

The form used in the examples in this reference manual is a guide to document the team's discussions and analysis of the PFMEA elements. It contains the *minimum* content that is normally expected by the OEMs.

Column order can be modified and columns can be added to this form depending on the organization and customer needs and expectations. In any case, any form submitted must be acceptable to the customer.

Header of the Process FMEA Form (fields A-H)

The following describes the information to be entered on the form.

The PFMEA header should clearly identify the focus of the PFMEA as well as information related to the document development and control process. This should include an FMEA number, identification of the scope, design responsibility, completion dates, etc. The header should contain the following elements⁸:

FMEA Number (A)

Enter an alphanumeric string which is used to identify the PFMEA document. This is used for document control.

Item (B)

Enter the name and number of the system, subsystem or component for which the process is being analyzed.

Process Responsibility (C)

Enter the OEM, organization, and department or group who is process design responsible. Also enter the supply organization name, if applicable.

Model Year(s)/Program(s) (D)

Enter the intended model year(s) and program(s) that will use or be affected by the process being analyzed (if known).

⁸ The letters at the end of each heading indicate the area referred to on the sample form.

FMEA Number A
 Page H of
 Prepared By: H F
 FMEA Date (Orig.)

POTENTIAL FAILURE MODE AND EFFECTS ANALYSIS (PROCESS FMEA)
 Process Responsibility C E
 Key Date

Item: B D G
 Model Year(s)/Program(s)
 Core Team

Process Step / Function	Requirement	Potential Failure Mode	Potential Effect(s) of Failure	Severity	Classification	Potential Cause(s) of Failure	Current Process			Recommended Action	Responsibility & Target Completion Date	Action Results					
							Controls Prevention	Controls Detection	RPN			Actions Taken	Completion Date	Severity	Occurrence	Detection	RPN
Op 70: Manual application of wax inside door panel	Cover inner door, lower surfaces with wax to specification thickness	Insufficient wax coverage over specified surface	Allows integrity breach of inner door panel Corroded interior lower door panels Deteriorated life of door leading to: • Unsatisfactory appearance due to rust through paint over time. • Impaired function of interior door hardware	7		Manually inserted spray head not inserted far enough	None	8	Variables check for film thickness Visual check for coverage.	280	Mfg Engineering by DX 10 15	Stop added, sprayer checked online	7	2	5	70	
			Spray head clogged - Viscosity too high - Temperature too low - Pressure too low			Test spray at start-up and after life periods and preventative maintenance program to clean heads	5	Variables check for film thickness Visual check for coverage.	175	Mfg Engineering by DX 10 01	Rejected due to complexity of different doors on the same line	Temp and Press Limits were determined and limit controls have been installed. Control charts show process is in control Cpk=1.85	7	1	5	35	
			Spray head deformed due to impact			Preventative maintenance programs to maintain heads	2	Variables check for film thickness Visual check for coverage.	70	None							
			Spray time sufficient			None	5	Operator instructions Lot sampling (visual) check coverage of critical areas	245	Maintenance XXX/XX/XX	Automatic spray timer installed- operator starts spray, timer controls shut-off control charts show process is in control - Cpk=2.05	7	1	7	49		
a1	a2	b	c	d	e	f	h	g	h	i	j	k	l	m	n	o	p
		Excessive wax coverage over specified surface															

Table IV.1 Sample PFMEA Form with Minimal Information Elements & Example Entries

Key Date (E)

Enter the initial PFMEA due date, which should not exceed the scheduled start of production date. In case of a supply organization, this date should not exceed the customer required Production Part Approval Process (PPAP) submission date.

FMEA Date (Original) (F)

Enter the date the original PFMEA was completed and the latest revision date.

Core Team (G)

Enter the team members responsible for developing the PFMEA. Contact information (e.g., name, organization, telephone number, and email) may be included in a referenced supplemental document.

Prepared By (H)

Enter the name and contact information including the organization (company) of the engineer/team leader responsible for preparing the PFMEA.

Body of the PFMEA Form (fields a – n)

The body of the PFMEA contains the analysis of risks related to the potential failures and improvement action being taken.⁹

Process Step / Process Function / Requirements (a)

Process Step/Function can be separated into two (or more) columns or combined into a single, bridged column which encompasses these elements. Process Steps may be listed in the Process Step/Function column or additional column(s) may be added containing the functions or requirements of that process step. “Process Step”, “Function”, and “Requirements” are described below:

⁹ The letters at the end of each heading indicate the area referred to on the sample form.

FMEA Number A
 Page H of
 Prepared By: H F
 FMEA Date (Orig.)

POTENTIAL FAILURE MODE AND EFFECTS ANALYSIS (PROCESS FMEA)
 Process Responsibility C E
 Key Date

Item: B D G
 Model Year(s)/Program(s)
 Core Team

Process Step / Function	Requirement	Potential Failure Mode	Potential Effect(s) of Failure	Severity	Classification	Potential Cause(s) of Failure	Current Process			Recommended Action	Responsibility & Target Completion Date	Action Results					
							Controls Prevention	Controls Detection	RPN			Actions Taken	Completion Date	Severity	Occurrence	Detection	RPN
Op 70: Manual application of wax inside door panel	Cover inner door, lower surfaces with wax to specification thickness	Insufficient wax coverage over specified surface	Allows integrity breach of inner door panel Corroded interior lower door panels Deteriorated life of door leading to: • Unsatisfactory appearance due to rust through paint over time. • Impaired function of interior door hardware	7		Manually inserted spray head not inserted far enough	None	8	Variables check for film thickness Visual check for coverage.	280	Mfg Engineering by DX 10 15	Stop added, sprayer checked online	7	2	5	70	
			Spray head clogged - Viscosity too high - Temperature too low - Pressure too low				Test spray at start-up and after life periods and preventative maintenance program to clean heads	5	Variables check for film thickness Visual check for coverage.	175	Mfg Engineering by DX 10 01	Rejected due to complexity of different doors on the same line	7	1	5	35	
			Spray head deformed due to impact				Preventative maintenance programs to maintain heads	2	Variables check for film thickness Visual check for coverage.	70							
			Spray time sufficient				None	5	Operator instructions (visual) check coverage of critical areas	245	Maintenance XXX/XX/XX	Automatic spray timer installed- operator starts spray, timer controls shut-off control charts show process is in control - CpK=2.05	7	1	7	49	
a1	a2	b	c	d	e	f	h	g	h	i	j	k	l	m	n	o	p
		Excessive wax coverage over specified surface															

Table IV.1 Sample PFMEA Form with Minimal Information Elements & Example Entries

Process Step (a1)

Enter the identification of the process step or operation being analyzed, based on the numbering process and terminology. For example, enter the number and identifier (e.g., name). Process numbering scheme, sequencing, and terminology used should be consistent with those used in the process flow diagram to ensure traceability and relationships to other documents (Control Plans, operator instructions, etc). Repair and rework operations should also be included.

Process Function (a1)

List the process function that corresponds to each process step or operation being analyzed. The process function describes the purpose or intent of the operation. A risk analysis is recommended in order to limit the number of steps to be included to only those that add value or otherwise are seen as likely to have a negative impact on the product. If there are multiple process functions being analyzed with respect to a given operation, each should be aligned on the form with its respective “Requirements” to aid in the development of the associated failure modes.

Process Function becomes a2 if Process Step and Process Function are split.

Requirements (a2)

List the requirements for each process function of the process step or operation being analyzed. Requirements are the inputs to the process specified to meet design intent and other customer requirements. If there are multiple requirements with respect to a given function, each should be aligned on the form with the respective associated failure modes in order to facilitate the analysis.

Requirements become a3 if Process Step and Process Function are split into separate columns, e.g., a1 and a2.

FMEA Number A
 Page H of
 Prepared By: H F
 FMEA Date (Orig.) F

POTENTIAL FAILURE MODE AND EFFECTS ANALYSIS (PROCESS FMEA)
 Process Responsibility C E
 Key Date E

Item: B D G
 Model Year(s)/Program(s)
 Core Team

Process Step / Function	Requirement	Potential Failure Mode	Potential Effect(s) of Failure	Severity	Classification	Potential Cause(s) of Failure	Current Process			Recommended Action	Responsibility & Target Completion Date	Action Results					
							Controls Prevention	Controls Detection	RPN			Actions Taken	Completion Date	Severity	Occurrence	Detection	RPN
Op 70: Manual application of wax inside door panel	Cover inner door, lower surfaces with wax to specification thickness	Insufficient wax coverage over specified surface	Allows integrity breach of inner door panel Corroded interior lower door panels Deteriorated life of door leading to: •Unsatisfactory appearance due to rust through paint over time. • Impaired function of interior door hardware	7		Manually inserted spray head not inserted far enough	None	8	Variables check for film thickness Visual check for coverage.	280	Mfg Engineering by DX 10 15	Stop added, sprayer checked online	7	2	5	70	
			Spray head clogged - Viscosity too high - Temperature too low - Pressure too low				Test spray at start-up and after life periods and preventative maintenance program to clean heads	5	Variables check for film thickness Visual check for coverage.	175	Mfg Engineering by DX 10 01	Rejected due to complexity of different doors on the same line	7	1	5	35	
			Spray head deformed due to impact				Preventative maintenance programs to maintain heads	2	Variables check for film thickness Visual check for coverage.	70							
			Spray time sufficient				None	5	Operator instructions (visual) check coverage of critical areas	245	Maintenance XXX/XX/XX	Automatic spray timer installed- operator starts spray, timer controls shut-off control charts show process is in control - CpK=2.05	7	1	7	49	
a1	a2	b	c	d	e	f	h	g	h	i	j	k	l	m	n	o	p
		Excessive wax coverage over specified surface															

Table IV.1 Sample PFMEA Form with Minimal Information Elements & Example Entries

Potential Failure Mode (b)

Potential failure mode is defined as the manner in which the process could potentially fail to meet the process requirements (including the design intent).

In preparing the FMEA, assume that the incoming part(s)/material(s) are correct. Exceptions can be made by the FMEA team where historical data indicate deficiencies in incoming part quality. The team should also assume that the basic design of the product is correct; however, if there are design issues which result in process concerns, those issues should be communicated to the design team for resolution.

List the potential failure mode(s) for the particular operation in terms of the process requirement(s) (e.g., as documented in the process flow diagram.) Assume that the failure could occur but may not necessarily occur. Potential failure modes should be described in technical terms, not as a symptom noticeable by the customer. See the example table below.

Process Step/Function	Requirement	Potential Failure Mode
Operation 20: Attach seat cushion to track using a torque gun	Four screws	Fewer than four screws
	Specified screws	Wrong screw used (larger dia)
	Assembly sequence: First screw in right front hole	Screw placed in any other hole
	Screws fully seated	Screw not fully seated
	Screws torqued to dynamic torque specification	Screw torqued too high

Table IV.2 Example of Process Step/Function/Requirements Columns on PFMEA Form including Potential Failure Modes

If the requirements have been well defined, then the potential failure mode is readily identifiable by determining the condition when a specific requirement is not met. Each requirement may have multiple failure modes. A large number of failure modes identified for a single requirement usually indicates that the requirement is not well defined.

The assumption is made that the failure could occur but may not necessarily occur – consequently the use of the word “potential”.

Verification of completeness of the potential failure modes can be made through a review of past things-gone-wrong, concerns,

POTENTIAL
FAILURE MODE AND EFFECTS ANALYSIS
(PROCESS FMEA)

FMEA Number A Page H of F

Prepared By: C Process Responsibility E

Item: B Key Date E

Model Year(s)/Program(s) D

Core Team G

Process Step	Function	Requirement	Potential Failure Mode	Potential Effect(s) of Failure	Severity	Classification	Potential Cause(s) of Failure	Current Process			Recommended Action	Responsibility & Target Completion Date	Action Results					
								Controls Prevention	Controls Detection	Detection			RPN	Actions Taken	Completion Date	Severity	Occurrence	Detection
Op 70- Manual application of wax inside door panel	Cover inner door, lower surfaces with wax to specification thickness	Insufficient wax coverage over specified surface	Allows integrity breach of inner door panel Corroded interior lower door panels Deteriorated life of door leading to: • Unsatisfactory appearance due to rust through paint over time. • Impaired function of interior door hardware	7			Manually inserted spray head not inserted far enough	8	Variables check for film thickness Visual check for coverage.	5	Add positive depth stop to sprayer Automate spraying	Mfg Engineering by OX 10 15	Stop added, sprayer checked online	7	2	5	70	
				Spray head clogged - Viscosity too high - Temperature too low - Pressure too low	5		Test spray at start-up and after life periods and preventative maintenance program to clean heads	5	Variables check for film thickness Visual check for coverage.	5	Use Design of experiments (DOE) on viscosity vs. temperature vs. pressure	Mfg Engineering by OX 10 01	Temp and Press Limits were determined and limit controls have been installed. Control charts show process is in control Cpk=1.85	7	1	5	35	
				Spray head deformed due to impact	2		Preventative maintenance programs to maintain heads	2	Variables check for film thickness Visual check for coverage.	5	None							
				Spray time sufficient	5		None	5	Operator instructions Lot sampling (visual) check coverage of critical areas	7	Install Spray timer.	Maintenance XXX/XXX	Automatic spray timer installed- operator starts spray, timer controls shut-off control charts show process is in control - Cpk=2.05	7	1	7	49	
a1	a2	b	c	d	e	f	g	h	i	j	k	l	m	n	o	p	q	r
		Excessive wax coverage over specified surface																

Table IV.1 Sample PFMEA Form with Minimal Information Elements & Example Entries

reject or scrap reports, and group brainstorming. Sources for this should also include a comparison of similar processes and a review of customer (End User and subsequent operation) claims relating to similar components.

Potential Effect(s) of Failure (c)

Potential effects of failure are defined as the effects of the failure mode as perceived by the customer(s).

The effects of the failure should be described in terms of what the customer might notice or experience, remembering that the customer may be an internal customer as well as the ultimate End User. The customer(s) in this context could be the next operation, subsequent operations or locations, the dealer, and/or the vehicle owner. Each must be considered when assessing the potential effect of a failure. The product effects in the PFMEA should be consistent with those in the corresponding DFMEA.

If the failure mode could impact safety or cause noncompliance to regulations, this should be clearly identified in the PFMEA.

For the End User, the effects should be stated in terms of product or system performance. If the customer is the next operation or subsequent operation(s) / location(s), the effects should be stated in terms of process / operation performance. See Table IV.3 Example of Effects.

In order to determine the Potential Effect(s), the following questions should be asked:

1. Does the Potential Failure Mode physically prevent downstream processing or cause potential harm to equipment or operators?

This includes an inability to assemble or join to a mating component at any subsequent customer's facility. If so, then assess the manufacturing impact. No further analysis is required. If not, then go to question 2. Examples could include:

- Unable to assemble at operation x
- Unable to attach at customer facility
- Unable to connect at customer facility
- Cannot bore at operation x
- Causes excessive tool wear at operation x
- Damages equipment at operation x
- Endangers operator at customer facility

Note: The location, station or operation at which the effect occurs should be identified. If at a customer's facility, this should be stated.

2. What is the potential impact on the End User?

Independent of any controls planned or implemented including error or mistake-proofing, consider what the End User would notice or experience. This information may be available within the DFMEA. Once determined, go to question 3. Examples could include:

- Noise
- High effort
- Unpleasant odor
- Intermittent operation
- Water leak
- Rough idle
- Unable to adjust
- Difficult to control
- Poor appearance

3. What would happen if an effect was detected prior to reaching the End User?

The potential effect at the current or receiving locations also needs to be considered. Examples could include:

- Line shutdown
- Stop shipment
- Yard hold
- 100% of product scrapped
- Decreased line speed
- Added manpower to maintain required line rate

Note: If more than one potential effect is identified when considering questions 2 and 3, all may be listed, but for purposes of the analysis, only consider the worst case when documenting the resulting Severity ranking.

Example of Effects

Requirement	Failure Mode	Effect
Four screws	Fewer than four screws	<i>EndUser:</i> Loose seat cushion and noise. <i>Manufacturing and Assembly:</i> Stop shipment and additional sort and rework due to affected portion.
Specified screws	Wrong screw used (larger dia.)	<i>Manufacturing and Assembly:</i> Unable to install screw in station.
Assembly sequence: First screw in right front hole	Screw placed in any other hole	<i>Manufacturing and Assembly:</i> Difficult to install remaining screws in station.
Screws fully seated	Screw not fully seated	<i>End User:</i> Loose seat cushion and noise. <i>Manufacturing and Assembly:</i> Sort and rework due to affected portion.
Screws torqued to dynamic torque specification	Screw torqued too high	<i>End User:</i> Loose seat cushion due to subsequent fracture of screw and noise. <i>Manufacturing and Assembly:</i> Sort and rework due to affected portion.
	Screw torqued too low	<i>End User:</i> Loose seat cushion due to gradual loosening of screw and noise. <i>Manufacturing and Assembly:</i> Sort and rework due to affected portion.

Table IV.3 Example of Effects

FMEA Number A
 Page H of
 Prepared By: H
 FMEA Date (Orig.) F

POTENTIAL FAILURE MODE AND EFFECTS ANALYSIS (PROCESS FMEA)
 Process Responsibility C
 Key Date E

Item: B
 Model Year(s)/Program(s) D
 Core Team G

Process Step / Function	Requirement	Potential Failure Mode	Potential Effect(s) of Failure	Severity	Classification	Potential Cause(s) of Failure	Current Process			Recommended Action	Responsibility & Target Completion Date	Action Results				
							Controls Prevention	Controls Detection	RPN			Actions Taken	Completion Date	Severity	Occurrence	Detection
Op 70: Manual application of wax inside door panel	Cover inner door, lower surfaces with wax to specification thickness	Insufficient wax coverage over specified surface	Allows integrity breach of inner door panel Corroded interior lower door panels Deteriorated life of door leading to: • Unsatisfactory appearance due to rust through paint over time. • Impaired function of interior door hardware	7		Manually inserted spray head not inserted far enough	None	8	Variables check for film thickness Visual check for coverage.	5	280	Stop added, sprayer checked online	7	2	70	
			Spray head clogged - Viscosity too high - Temperature too low - Pressure too low			Test spray at start-up and after life periods and preventative maintenance program to clean heads	5	Variables check for film thickness Visual check for coverage.	5	175	Mig Engineering by DX 10 15 Mig Engineering by DX 12 15 Mig Engineering by DX 10 01	Temp and Press Limits were determined and limit controls have been installed. Control charts show process is in control CpK=1.85	7	1	35	
			Spray head deformed due to impact			Preventative maintenance programs to maintain heads	2	Variables check for film thickness Visual check for coverage.	5	70	None					
			Spray time sufficient			None	5	Operator instructions (visual) check coverage of critical areas	7	245	Maintenance XXX/XX/XX	Automatic spray timer installed- operator starts spray, timer controls shut-off control charts show process is in control - CpK=2.05	7	1	49	
a1	a2	b	c	d	e	f	h	g	h	i	j	k	l	m	n	o
		Excessive wax coverage over specified surface														

Table IV.1 Sample PFMEA Form with Minimal Information Elements & Example Entries

Severity (S) (*d*)

Severity is the value associated with the most serious effect for a given failure mode. Severity is a relative ranking within the scope of the individual FMEA.

Suggested Evaluation Criteria

The team should agree on evaluation criteria and a ranking system and apply them consistently, even if modified for individual process analysis (See Table Cr1 for criteria guidelines).

It is not recommended to modify criteria for ranking values 9 and 10. Failure modes with a rank of 1 should not be analyzed further.

Effect	Criteria: Severity of Effect on Product (Customer Effect)	Rank	Effect	Criteria: Severity of Effect on Process (Manufacturing/Assembly Effect)
Failure to Meet Safety and/or Regulatory Requirements	Potential failure mode affects safe vehicle operation and/or involves noncompliance with government regulation without warning.	10	Failure to Meet Safety and/or Regulatory Requirements	May endanger operator (machine or assembly) without warning.
	Potential failure mode affects safe vehicle operation and/or involves noncompliance with government regulation with warning.	9		
Loss or Degradation of Primary Function	Loss of primary function (vehicle inoperable, does not affect safe vehicle operation).	8	Major Disruption	100% of product may have to be scrapped. Line shutdown or stop ship.
	Degradation of primary function (vehicle operable, but at reduced level of performance).	7	Significant Disruption	A portion of the production run may have to be scrapped. Deviation from primary process including decreased line speed or added manpower.
Loss or Degradation of Secondary Function	Loss of secondary function (vehicle operable, but comfort / convenience functions inoperable).	6	Moderate Disruption	100% of production run may have to be reworked off line and accepted.
	Degradation of secondary function (vehicle operable, but comfort / convenience functions at reduced level of performance).	5		A portion of the production run may have to be reworked off line and accepted.
Annoyance	Appearance or Audible Noise, vehicle operable, item does not conform and noticed by most customers (> 75%).	4	Moderate Disruption	100% of production run may have to be reworked in station before it is processed.
	Appearance or Audible Noise, vehicle operable, item does not conform and noticed by many customers (50%).	3		A portion of the production run may have to be reworked in-station before it is processed.
	Appearance or Audible Noise, vehicle operable, item does not conform and noticed by discriminating customers (< 25%).	2		Slight inconvenience to process, operation, or operator.
No effect	No discernible effect.	1	No effect	No discernible effect.

Table Cr1 Suggested PFMEA Severity Evaluation Criteria

This page intentionally left blank.

POTENTIAL
FAILURE MODE AND EFFECTS ANALYSIS
(PROCESS FMEA)

FMEA Number A Page H of

Prepared By: F FMEA Date (Orig.)

Item: B Process Responsibility C

Model Year(s)/Program(s) D Key Date E

 G

Core Team _____

Process Step	Requirement	Potential Failure Mode	Potential Effect(s) of Failure	Severity	Classification	Potential Cause(s) of Failure	Current Process			RPN	Recommended Action	Responsibility & Target Completion Date	Action Results					
							Controls Prevention	Controls Detection	Detection				Actions Taken	Completion Date	Severity	Occurrence	Detection	RPN
Op 70- Manual application of wax inside door panel	Cover inner door, lower surfaces with wax to specification thickness	Insufficient wax coverage over specified surface	Allows integrity breach of inner door panel Corroded interior lower door panels Deteriorated life of door leading to: •Unsatisfactory appearance due to rust through paint over time. • Impaired function of interior door hardware	7		Manually inserted spray head not inserted far enough	None	8	Variables check for film thickness Visual check for coverage.	5	Add positive depth stop to sprayer Automate spraying	Mfg Engineering by OX 10 15	Stop added, sprayer checked online	7	2	5	70	
						Spray head clogged - Viscosity too high - Temperature too low - Pressure too low	Test spray at start-up and after life periods and preventative maintenance program to clean heads	5	Variables check for film thickness Visual check for coverage.	5	Use Design of experiments (DOE) on viscosity vs. temperature vs. pressure	Mfg Engineering by OX 10 01	Temp and Press Limits were determined and limit controls have been installed. Control charts show process is in control Cpk=1.85	7	1	5	35	
						Spray head deformed due to impact	Preventative maintenance programs to maintain heads	2	Variables check for film thickness Visual check for coverage.	5	None							
						Spray time sufficient	None	5	Operator instructions Lot sampling (visual) check coverage of critical areas	7	Install Spray timer.	Maintenance XXX/XXX	Automatic spray timer installed- operator starts spray, timer controls shut-off control charts show process is in control – Cpk=2.05	7	1	7	49	
a1	a2	b	c	d	e	f	h	g	h	i	j	k	l	m	n	o	p	q
		Excessive wax coverage over specified surface																

Table IV.1 Sample PFMEA Form with Minimal Information Elements & Example Entries

Classification (e)

This column may be used to highlight high priority failure modes or causes that may require additional engineering assessment.

This column may also be used to classify any special product or process characteristics (e.g., critical, key, major, significant) for components, subsystems, or systems that may require additional process controls.

Customer specific requirements may identify special product or process characteristic symbols and their usage.

Where a special characteristic is identified with a severity of 9 or 10 in the PFMEA, the design responsible engineer should be notified since this may affect the engineering documents.

Potential Cause(s) of Failure Mode (f)

Potential cause of failure is defined as an indication of how the failure could occur, and is described in terms of something that can be corrected or can be controlled. Potential cause of failure may be an indication of a design or process weakness, the consequence of which is the failure mode.

To the extent possible, identify and document every potential cause for each failure mode. The cause should be detailed as concisely and completely as possible. Separating the causes will result in a focused analysis for each and may yield different measurement, controls, and action plans. There may be one or more causes that can result in the failure mode being analyzed. This results in multiple lines for each cause in the table or form.¹⁰

In preparing the PFMEA, the team should assume that the incoming part(s)/material(s) are correct. Exceptions can be made at the team's discretion where historical data indicate deficiencies in incoming part quality.

Only specific errors or malfunctions (e.g., seal not installed or seal installed inverted) should be listed. Ambiguous phrases (e.g., operator error or seal mis-installed, etc.) should not be used. See Table IV.4 Example of Causes and Controls.

¹⁰ In preparing the PFMEA, the team needs to ensure that any limitations of the design that may result in a potential process failure mode are communicated to the design function.

Occurrence (O) (g)

Occurrence is the likelihood that a specific cause of failure will occur. The likelihood of occurrence ranking number has a relative meaning rather than an absolute value (See Table Cr2).

Estimate the likelihood of occurrence of a potential cause of failure on a 1 to 10 scale. A consistent occurrence ranking system should be used to ensure continuity. The occurrence ranking number is a relative ranking within the scope of the FMEA and may not reflect the actual likelihood of occurrence.

The “Incident per items/vehicles” is used to indicate the number of failures that are anticipated during the process execution. If statistical data are available from a similar process, the data should be used to determine the occurrence ranking. In other cases, a subjective assessment can be made by using the word descriptions in the left hand column of the table, along with input from the appropriate process knowledge source to estimate the ranking.

Suggested Evaluation Criteria

The team should agree on evaluation criteria and a ranking system and apply them consistently, even if modified for individual process analysis. Occurrence should be estimated using a 1 to 10 scale based upon Table Cr2 as a guideline.

Likelihood of Failure	Criteria: Occurrence of Cause - PFMEA (Incidents per items/vehicles)	Rank
Very High	≥ 100 per thousand ≥ 1 in 10	10
High	50 per thousand 1 in 20	9
	20 per thousand 1 in 50	8
	10 per thousand 1 in 100	7
Moderate	2 per thousand 1 in 500	6
	.5 per thousand 1 in 2,000	5
	.1 per thousand 1 in 10,000	4
Low	.01 per thousand 1 in 100,000	3
	$\leq .001$ per thousand 1 in 1,000,000	2
Very Low	Failure is eliminated through preventive control.	1

Table Cr2 Suggested PFMEA Occurrence Evaluation Criteria

FMEA Number A
 Page H of
 Prepared By: H
 FMEA Date (Orig.) F

POTENTIAL FAILURE MODE AND EFFECTS ANALYSIS (PROCESS FMEA)
 Process Responsibility C
 Key Date E

Item: B
 Model Year(s)/Program(s) D
 Core Team G

Process Step / Function	Requirement	Potential Failure Mode	Potential Effect(s) of Failure	Severity	Classification	Potential Cause(s) of Failure	Current Process			Recommended Action	Responsibility & Target Completion Date	Action Results					
							Controls Prevention	Controls Detection	RPN			Actions Taken	Completion Date	Severity	Occurrence	Detection	RPN
Op 70: Manual application of wax inside door panel	Cover inner door, lower surfaces with wax to specification thickness	Insufficient wax coverage over specified surface	Allows integrity breach of inner door panel Corroded interior lower door panels Deteriorated life of door leading to: • Unsatisfactory appearance due to rust through paint over time. • Impaired function of interior door hardware	7		Manually inserted spray head not inserted far enough	None	8	Variables check for film thickness Visual check for coverage.	280	Mfg Engineering by DX 10 15	Stop added, sprayer checked online	7	2	5	70	
			Spray head clogged - Viscosity too high - Temperature too low - Pressure too low			Test spray at start-up and after life periods and preventative maintenance program to clean heads	5	Variables check for film thickness Visual check for coverage.	175	Mfg Engineering by DX 10 01	Rejected due to complexity of different doors on the same line	Temp and Press Limits were determined and limit controls have been installed. Control charts show process is in control CpK=1.85	7	1	5	35	
			Spray head deformed due to impact			Preventative maintenance programs to maintain heads	2	Variables check for film thickness Visual check for coverage.	70	None							
			Spray time sufficient			None	5	Operator instructions (visual) check coverage of critical areas	245	Maintenance XXX/XX/XX	Automatic spray timer installed- operator starts spray, timer controls shut-off control charts show process is in control - CpK=2.05	7	1	7	49		
a1	a2	b	c	d	e	f	h	g	i	j	k	l	m	n	o	p	q
		Excessive wax coverage over specified surface															

Table IV.1 Sample PFMEA Form with Minimal Information Elements & Example Entries

Current Process Controls (*h*)

Current Process Controls are descriptions of the controls that can either prevent to the extent possible, the cause of failure from occurring or detect the failure mode or cause of failure should it occur.

There are two types of Process Controls to consider:

Prevention:

Eliminate (prevent) the cause of the failure or the failure mode from occurring, or reduce its rate of occurrence.

Detection:

Identify (detect) the cause of failure or the failure mode, leading to the development of associated corrective action(s) or counter-measures.

The preferred approach is to first use prevention controls, if possible. The initial occurrence rankings will be affected by the prevention controls provided they are integrated as part of the process. The initial detection rankings will be based on process controls that either detect the cause of failure, or detect the failure mode.

Because statistical charting methods (i.e., Statistical Process Control)¹¹ typically use sampling to assess process stability and detect out-of-control conditions they should not be considered when evaluating the effectiveness of specific Detection Controls. SPC may, however, be considered as a Prevention Control for specific causes whose trends are identifiable in advance of an actual non-conformance being produced, such as tool wear.

The example PFMEA form in this manual has two separate columns for Prevention Controls and Detection Controls to assist the team in clearly distinguishing between these two types of controls. This allows for a quick visual determination that both types of process controls have been considered.

If a one-column (for process controls) form is used, then the following prefixes should be used. For prevention controls, place a 'P' before or after each prevention control listed. For detection controls, place a 'D' before or after each detection control listed (see Table IV.4 Example of Causes and Controls).

¹¹ See Chrysler, Ford, GM; *SPC Manual*, AIAG.

Requirement	Failure Mode	Cause	Prevention Control	Detection Control
Screws torqued until fully seated	Screw not fully seated	Nut runner not held perpendicular to work surface by operator	Operator training	Angle sensor included in nut runner to detect cross-threading not allowing part to be removed from fixture until value is satisfied
Screws torqued to dynamic torque specification	Screw torqued too high	Torque setting set too high by non-set-up personnel	Password protected control panel (only set-up personnel have access)	Torque validation box included in set-up procedure to validate setting prior to running
		Torque setting set too high by set-up personnel	Training of set-up personnel	Torque validation box included in set-up procedure to validate setting prior to running
			Settings added to set-up instructions	
	Screw torqued too low	Torque setting set too low by non-set-up personnel	Password protected control panel (only set-up personnel have access)	Torque validation box included in set-up procedure to validate setting prior to running
			Training of set-up personnel	Torque validation box included in set-up procedure to validate setting prior to running
		Torque setting set too low by set-up personnel	Settings added to set-up instructions	

Table IV.4 Examples of Causes and Controls

This page intentionally left blank.

POTENTIAL
FAILURE MODE AND EFFECTS ANALYSIS
(PROCESS FMEA)

FMEA Number A
 Page H of F
 Prepared By: H
 FMEA Date (Orig.) F

Item: B
 Model Year(s)/Program(s) D
 Core Team G

Process Responsibility C
 Key Date E

Process Step	Requirement	Potential Failure Mode	Potential Effect(s) of Failure	Severity	Classification	Potential Cause(s) of Failure	Current Process			RPN	Recommended Action	Responsibility & Target Completion Date	Action Results				
							Controls Prevention	Controls Detection	Detection				Actions Taken	Completion Date	Severity	Occurrence	Detection
Op 70: Manual application of wax inside door panel	Cover inner door, lower surfaces with wax to specification thickness	Insufficient wax coverage over specified surface	Allows integrity breach of inner door panel Corroded interior lower door panels Deteriorated life of door leading to: • Unsatisfactory appearance due to rust through paint over time. • Impaired function of interior door hardware	7		Manually inserted spray head not inserted far enough	None	8	Variables check for film thickness Visual check for coverage.	5	Add positive depth stop to sprayer Automate spraying	Mfg Engineering by OX 10 15	7	2	5	70	
						Spray head clogged - Viscosity too high - Temperature too low - Pressure too low	Test spray at start-up and after life periods and preventative maintenance program to clean heads	5	Variables check for film thickness Visual check for coverage.	5	Use Design of experiments (DOE) on viscosity vs. temperature vs. pressure	Mfg Engineering by OX 10 01	7	1	5	35	
						Spray head deformed due to impact	Preventative maintenance programs to maintain heads	2	Variables check for film thickness Visual check for coverage.	5	None						
						Spray time sufficient	None	5	Operator instructions Lot sampling (visual) check coverage of critical areas	7	Install Spray timer.	Maintenance XXX/XXX	7	1	7	49	
a1	a2	b	c	d	e	f	h	g	h	i	j	k	l	m	n	o	p
		Excessive wax coverage over specified surface															

Table IV.1 Sample PFMEA Form with Minimal Information Elements & Example Entries

Detection (D) (i)

Detection is the rank associated with the best detection control listed in the Detection Controls column. Detection is a relative ranking within the scope of the individual FMEA. In order to achieve a lower ranking, generally the planned detection control has to be improved.

When more than one control is identified, it is recommended that the detection ranking of each control be included as part of the description of the control. Record the lowest ranking value in the Detection column.

Assume the failure has occurred and then assess the capabilities of all "Current Process Controls" to prevent shipment of the part having this failure mode. Do not automatically presume that the detection ranking is low because the occurrence is low, but do assess the ability of the process controls to detect low frequency failure modes or prevent them from going further in the process.

Random quality checks are unlikely to detect the existence of an isolated problem and should not influence the detection ranking.

Suggested Evaluation Criteria

The team should agree on evaluation criteria and a ranking system and apply them consistently, even if modified for individual product analysis. Detection should be estimated using Table Cr3 as a guideline.

The ranking value of one (1) is reserved for failure prevention through proven process design solutions.

Opportunity for Detection	Criteria: Likelihood of Detection by Process Control	Rank	Likelihood of Detection
No detection opportunity	No current process control; Cannot detect or is not analyzed.	10	Almost Impossible
Not likely to detect at any stage	Failure Mode and/or Error (Cause) is not easily detected (e.g., random audits).	9	Very Remote
Problem Detection Post Processing	Failure Mode detection post-processing by operator through visual/tactile/audible means.	8	Remote
Problem Detection at Source	Failure Mode detection in-station by operator through visual/tactile/audible means or post-processing through use of attribute gauging (go/no-go, manual torque check/clicker wrench, etc.).	7	Very Low
Problem Detection Post Processing	Failure Mode detection post-processing by operator through use of variable gauging or in-station by operator through use of attribute gauging (go/no-go, manual torque check/clicker wrench, etc).	6	Low
Problem Detection at Source	Failure Mode or Error (Cause) detection in-station by operator through use of variable gauging or by automated controls in-station that will detect discrepant part and notify operator (light, buzzer, etc.). Gauging performed on setup and first-piece check (for set-up causes only).	5	Moderate
Problem Detection Post Processing	Failure Mode detection post-processing by automated controls that will detect discrepant part and lock part to prevent further processing.	4	Moderately High
Problem Detection at Source	Failure Mode detection in-station by automated controls that will detect discrepant part and automatically lock part in station to prevent further processing.	3	High
Error Detection and/or Problem Prevention	Error (Cause) detection in-station by automated controls that will detect error and prevent discrepant part from being made.	2	Very High
Detection not applicable; Error Prevention	Error (Cause) prevention as a result of fixture design, machine design or part design. Discrepant parts cannot be made because item has been error-proofed by process/product design.	1	Almost Certain

Table Cr3 Suggested Process FMEA Detection Evaluation Criteria

This page intentionally left blank

FMEA Number A
 Page H of
 Prepared By: H F
 FMEA Date (Orig.)

POTENTIAL FAILURE MODE AND EFFECTS ANALYSIS (PROCESS FMEA)
 Process Responsibility C E
 Key Date

Item: B D G
 Model Year(s)/Program(s)
 Core Team

Process Step / Function	Requirement	Potential Failure Mode	Potential Effect(s) of Failure	Severity	Classification	Potential Cause(s) of Failure	Current Process			Recommended Action	Responsibility & Target Completion Date	Action Results					
							Controls Prevention	Controls Detection	RPN			Actions Taken	Completion Date	Severity	Occurrence	Detection	RPN
Op 70: Manual application of wax inside door panel	Cover inner door, lower surfaces with wax to specification thickness	Insufficient wax coverage over specified surface	Allows integrity breach of inner door panel Corroded interior lower door panels Deteriorated life of door leading to: • Unsatisfactory appearance due to rust through paint over time. • Impaired function of interior door hardware	7		Manually inserted spray head not inserted far enough	None	8	Variables check for film thickness Visual check for coverage.	280	Mfg Engineering by DX 10 15	Stop added, sprayer checked online	7	2	5	70	
			Spray head clogged - Viscosity too high - Temperature too low - Pressure too low				Test spray at start-up and after life periods and preventative maintenance program to clean heads	5	Variables check for film thickness Visual check for coverage.	175	Mfg Engineering by DX 10 01	Rejected due to complexity of different doors on the same line	7	1	5	35	
			Spray head deformed due to impact				Preventative maintenance programs to maintain heads	2	Variables check for film thickness Visual check for coverage.	70							
			Spray time sufficient				None	5	Operator instructions (visual) check coverage of critical areas	245	Maintenance XXX/XXX	Automatic spray timer installed- operator starts spray, timer controls shut-off control charts show process is in control - CpK=2.05	7	1	7	49	
a1	a2	b	c	d	e	f	h	g	h	i	j	k	l	m	n	o	p
		Excessive wax coverage over specified surface															

Table IV.1 Sample PFMEA Form with Minimal Information Elements & Example Entries

Determining Action Priorities

Once the team has completed the initial identification of failure modes and effects, causes and controls, including rankings for severity, occurrence and detection, they must decide if further efforts are needed to reduce the risk. Due to the inherent limitations on resources, time, technology, and other factors, they must choose how to best prioritize these efforts.

The initial focus of the team should be oriented towards failure modes with the highest severity rankings. When the severity is 9 or 10, it is imperative that the team ensure that the risk is addressed through existing design controls or recommended actions (as documented in the FMEA).

For failure modes with severities of 8 or below the team should consider causes having the highest occurrence or detection rankings. It is the team's responsibility to look at the information, decide upon an approach, and determine how to best prioritize their risk reduction efforts which best serve their organization and customers.

Risk Evaluation; Risk Priority Number (RPN) (*j*)

One approach to assist in action prioritization has been to use the Risk Priority Number:

$$\text{RPN} = \text{Severity (S)} \times \text{Occurrence (O)} \times \text{Detection (D)}$$

Within the scope of the individual FMEA, this value can range between 1 and 1000.

The use of an RPN threshold is NOT a recommended practice for determining the need for actions.

Applying thresholds assumes that RPNs are a measure of relative risk (which they often are not) and that continuous improvement is not required (which it is).

For example, if the customer applied an arbitrary threshold of 100 to the following, the supplier would be required to take action on the characteristic B with the RPN of 112.

Item	Severity	Occurrence	Detection	RPN
A	9	2	5	90
B	7	4	4	112

In this example, the RPN is higher for characteristic B than characteristic A. However, the priority should be to work on A with the higher severity of 9, although its RPN is 90 which is lower and below the threshold.

FMEA Number A
 Page H of
 Prepared By: H F
 FMEA Date (Orig.)

POTENTIAL FAILURE MODE AND EFFECTS ANALYSIS (PROCESS FMEA)
 Process Responsibility C E
 Key Date

Item: B D G
 Model Year(s)/Program(s)
 Core Team

Process Step / Function	Requirement	Potential Failure Mode	Potential Effect(s) of Failure	Severity	Classification	Potential Cause(s) of Failure	Current Process			Recommended Action	Responsibility & Target Completion Date	Action Results					
							Controls Prevention	Controls Detection	RPN			Actions Taken	Completion Date	Severity	Occurrence	Detection	RPN
Op 70: Manual application of wax inside door panel	Cover inner door, lower surfaces with wax to specification thickness	Insufficient wax coverage over specified surface	Allows integrity breach of inner door panel Corroded interior lower door panels Deteriorated life of door leading to: • Unsatisfactory appearance due to rust through paint over time. • Impaired function of interior door hardware	7		Manually inserted spray head not inserted far enough	None	8	Variables check for film thickness Visual check for coverage.	280	Mfg Engineering by DX 10 15	Stop added, sprayer checked online	7	2	5	70	
			Spray head clogged - Viscosity too high - Temperature too low - Pressure too low				Test spray at start-up and after life periods and preventative maintenance program to clean heads	5	Variables check for film thickness Visual check for coverage.	175	Mfg Engineering by DX 10 01	Rejected due to complexity of different doors on the same line	7	1	5	35	
			Spray head deformed due to impact				Preventative maintenance programs to maintain heads	2	Variables check for film thickness Visual check for coverage.	70							
			Spray time sufficient				None	5	Operator instructions (visual) check coverage of critical areas	245	Maintenance XXX/XX/XX	Automatic spray timer installed- operator starts spray, timer controls shut-off control charts show process is in control - CpK=2.05	7	1	7	49	
a1	a2	b	c	d	e	f	h	g	h	i	j	k	l	m	n	o	p
		Excessive wax coverage over specified surface															

Table IV.1 Sample PFMEA Form with Minimal Information Elements & Example Entries

Another concern with using the threshold approach is that there is no specific RPN value that requires mandatory action.

Unfortunately, establishing such thresholds may promote the wrong behavior causing team members to spend time trying to justify a lower occurrence or detection ranking value to reduce the RPN. This type of behavior avoids addressing the real problem that underlies the cause of the failure mode and merely keeps the RPN below the threshold. It is important to recognize that while determining “acceptable” risk at a particular program milestone (e.g., vehicle launch) is desirable, it should be based on an analysis of severity, occurrence and detection and not through the application of RPN thresholds.

Use of the RPN index in the discussions of the team can be a useful tool. The limitations of the use of RPN need to be understood. However, the use of RPN thresholds to determine action priority is not recommended.

Recommended Action(s) (*k*)

In general, prevention actions (i.e., reducing the occurrence) are preferable to detection actions. An example of this is the use of process design error proofing rather than random quality checks or associated inspection.

The intent of any recommended action is to reduce rankings in the following order: severity, occurrence, and detection. Example approaches to reduce these are explained below:

- ***To Reduce Severity (S) Ranking:*** Only a design or process revision can bring about a reduction in the severity ranking.

A product/process design change, in and of itself, does not imply that the severity will be reduced. Any product/process design change should be reviewed by the team to determine the effect on the product functionality and process.

For maximum effectiveness and efficiency of this approach, changes to the product and process design should be implemented early in the development process. For example, process technology needs to be considered very early in the process development if severity is to be reduced.

- ***To Reduce Occurrence (O) Ranking:*** To reduce occurrence, process and design revisions may be required. A reduction in the occurrence ranking can be effected by removing or controlling one or more of the causes of the failure mode through a product or process design revision.

Studies to understand the sources of variation of the process using statistical methods may be implemented. These studies

FMEA Number A
 Page H of
 Prepared By: H F
 FMEA Date (Orig.)

POTENTIAL FAILURE MODE AND EFFECTS ANALYSIS (PROCESS FMEA)
 Process Responsibility C E
 Key Date

Item: B D G
 Model Year(s)/Program(s)
 Core Team

Process Step / Function	Requirement	Potential Failure Mode	Potential Effect(s) of Failure	Severity	Classification	Potential Cause(s) of Failure	Current Process			Recommended Action	Responsibility & Target Completion Date	Action Results					
							Controls Prevention	Controls Detection	RPN			Actions Taken	Completion Date	Severity	Occurrence	Detection	RPN
Op 70: Manual application of wax inside door panel	Cover inner door, lower surfaces with wax to specification thickness	Insufficient wax coverage over specified surface	Allows integrity breach of inner door panel Corroded interior lower door panels Deteriorated life of door leading to: • Unsatisfactory appearance due to rust through paint over time. • Impaired function of interior door hardware	7		Manually inserted spray head not inserted far enough	None	8	Variables check for film thickness Visual check for coverage.	5	280	Stop added, sprayer checked online	7	2	5	70	
			Spray head clogged - Viscosity too high - Temperature too low - Pressure too low				Test spray at start-up and after life periods and preventative maintenance program to clean heads	5	Variables check for film thickness Visual check for coverage.	5	175	Rejected due to complexity of different doors on the same line	7	1	5	35	
			Spray head deformed due to impact				Preventative maintenance programs to maintain heads	2	Variables check for film thickness Visual check for coverage.	5	70	Temp and Press Limits were determined and limit controls have been installed. Control charts show process is in control CpK=1.85					
			Spray time sufficient				None	5	Operator instructions (visual) check coverage of critical areas	7	245	Automatic spray timer installed- operator starts spray, timer controls shut-off control charts show process is in control - CpK=2.05	7	1	7	49	
a1	a2	b	c	d	e	f	h	g	h	i	j	k	l	m	n	o	p
		Excessive wax coverage over specified surface															

Table IV.1 Sample PFMEA Form with Minimal Information Elements & Example Entries

may result in actions that reduce occurrence. Further, the knowledge gained may assist in the identification of suitable controls including ongoing feedback of information to the appropriate operations for continuous improvement and problem prevention.

- **To Reduce Detection (D) Ranking:** The preferred method is the use of error/mistake proofing. A redesign of the detection methodology may result in a reduction of the detection ranking. In some cases, a design change to a process step may be required to increase the likelihood of detection (i.e., reduce the detection ranking.) Generally, improving detection controls requires the knowledge and understanding of the dominant causes of process variation and any special causes. Increasing the frequency of inspection is usually not an effective action and should only be used as a temporary measure to collect additional information on the process so that permanent preventive/corrective action can be implemented¹².

If the assessment leads to no recommended actions for a specific failure mode/cause/control combination, indicate this by entering “None” in this column. It may be useful to also include a rationale if “None” is entered, especially in case of high severity.

For process actions, the evaluation may include but is not limited to a review of:

- Results of process DOE or other testing when applicable
- Modified process flow diagram, floor plan, work instructions or preventive maintenance plan
- Review of equipment, fixtures or machinery specifications
- New or modified sensing/detection device

Table IV.5 below provides an example of the application of causes (Column f), controls (Column h) and recommended actions (Column k).

Responsibility & Target Completion Date (I)

Enter the name of the individual and organization responsible for completing each recommended action including the target completion date. The process-responsible engineer/team leader is responsible for ensuring that all actions recommended have been implemented or adequately addressed.

¹² See Chrysler, Ford, GM; *SPC Manual*, AIAG.

FMEA Number A
 Page H of
 Prepared By: H
 FMEA Date (Orig.) F

POTENTIAL FAILURE MODE AND EFFECTS ANALYSIS (PROCESS FMEA)
 Process Responsibility C
 Key Date E

Item: B
 Model Year(s)/Program(s) D
 Core Team G

Process Step / Function	Requirement	Potential Failure Mode	Potential Effect(s) of Failure	Severity	Classification	Potential Cause(s) of Failure	Current Process			Recommended Action	Responsibility & Target Completion Date	Action Results					
							Controls Prevention	Controls Detection	RPN			Actions Taken	Completion Date	Severity	Occurrence	Detection	RPN
Op 70: Manual application of wax inside door panel	Cover inner door, lower surfaces with wax to specification thickness	Insufficient wax coverage over specified surface	Allows integrity breach of inner door panel Corroded interior lower door panels Deteriorated life of door leading to: • Unsatisfactory appearance due to rust through paint over time. • Impaired function of interior door hardware	7		Manually inserted spray head not inserted far enough	None	8	Variables check for film thickness Visual check for coverage.	280	Mfg Engineering by DX 10 15	Stop added, sprayer checked online	7	2	5	70	
			Spray head clogged - Viscosity too high - Temperature too low - Pressure too low			Test spray at start-up and after life periods and preventative maintenance program to clean heads	5	Variables check for film thickness Visual check for coverage.	175	Mfg Engineering by DX 10 01	Rejected due to complexity of different doors on the same line	Temp and Press Limits were determined and limit controls have been installed. Control charts show process is in control CpK=1.85	7	1	5	35	
			Spray head deformed due to impact			Preventative maintenance programs to maintain heads	2	Variables check for film thickness Visual check for coverage.	70	None							
			Spray time sufficient			None	5	Operator instructions (visual) check coverage of critical areas	245	Maintenance XXX/XX/XX	Automatic spray timer installed- operator starts spray, timer controls shut-off control charts show process is in control - CpK=2.05	7	1	7	49		
a1	a2	b	c	d	e	f	h	g	h	i	j	k	l	m	n	o	p
		Excessive wax coverage over specified surface															

Table IV.1 Sample PFMEA Form with Minimal Information Elements & Example Entries

Action Results (*m-n*)

This section identifies the results of any completed actions and their effect on S, O, D rankings and RPN.

Action(s) Taken and Completion Date (*m*)

After the action has been implemented, enter a brief description of the action taken and actual completion date.

Severity, Occurrence, Detection and RPN (*n*)

After the preventive/corrective action has been completed, determine and record the resulting severity, occurrence, and detection rankings.

Calculate and record the resulting action (risk) priority indicator (e.g., RPN).

All revised rankings should be reviewed. Actions alone do not guarantee that the problem was solved (i.e., cause addressed), thus an appropriate analysis or test should be completed as verification. If further action is considered necessary, repeat the analysis. The focus should always be on continuous improvement.

Process Step/Function	Requirement	Failure Mode	Cause	Prevention Controls	Detection Controls	Recommended Actions
Op. 20 (attach seat cushion to track using a torque gun) Select four screws	Four screws	Fewer than four screws	Too few screws inadvertently installed	Visual aids illustrating correct quantity Operator training	Visual Inspection in station	In-station torque monitoring; Line lockout if fewer than four
	Specified screws	Wrong screw used (larger dia.)	Similar screws available at station	Visual aids illustrating correct screw Operator training	Visual inspection in station	In-station torque angle monitoring; Line lockout if angle not met Error proof by design: use one type screw for station/product
Op. 20 (attach seat cushion to track using a torque gun) Beginning with right front hole, torque each screw to the required torque	Assembly sequence: First screw in right front hole	Screw placed in any other hole	More than one hole available to operator	Visual aids identifying location of first screw Operator training	Visual inspection in station	Add position sensor to nut runner not allowing tool to operate unless runner is aligned with correct hole

Table IV.5 Examples of Causes, Controls and Actions

Maintaining PFMEAs

The PFMEA is a living document and should be reviewed whenever there is a product or process design change and updated, as required.

Another element of on-going maintenance of PFMEAs should include a periodic review. Specific focus should be given to Occurrence and Detection rankings. This is particularly important where there have been product or process changes or improvements in process controls. Additionally, in cases where either field issues or production issues, such as disruptions, have occurred, the rankings should be revised accordingly.

Leveraging PFMEAs

The use of a fundamentally sound PFMEA is the starting point that provides the greatest opportunity to leverage the use of past experience and knowledge.

If a new project or application is functionally similar to the existing product and the process to be used is similar, a single PFMEA may be used with customer concurrence. If there are differences, the team should identify and focus on the effects of these differences.

Linkages

The PFMEA is not a “stand-alone” document. Figure IV.5 shows some common linkages.

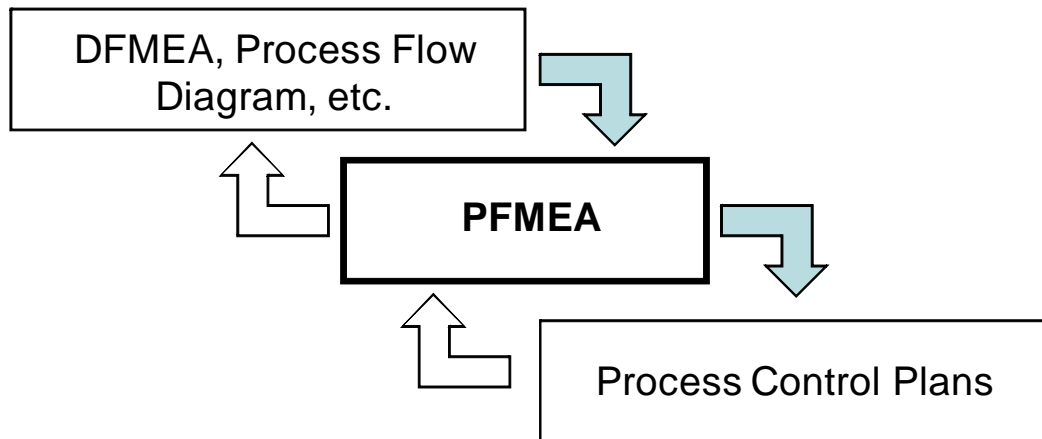

Figure IV.5 PFMEA Information Interrelationship Flow

To DFMEA

In the development of a PFMEA it is important to utilize the information and knowledge gained in the creation of the DFMEA. However, the link between the two documents is not always obvious. The difficulty occurs because the focus of each FMEA is different. The DFMEA focuses on part function whereas the PFMEA focuses on the manufacturing steps or process. Information in the columns of each form is not directly aligned. For example, Item/Function-Design does not equal Process Functions/Requirements; potential design failure mode does not equal potential process failure mode; potential design cause of failure does not equal potential process cause of failure. However, by comparing the overall analysis of design and process, a connection can be made. One such connection is between the characteristics identified during the DFMEA and PFMEA analysis.

Another connection is the relationship between potential design cause of failure (DFMEA) and potential process failure mode (PFMEA). For example, the design of a feature such as a hole can cause a particular failure mode. The corresponding process

failure mode is the inability of the process to manufacture the same feature as designed. In this example, the potential design cause of failure (hole diameter designed too large) would appear to be similar to the potential process failure mode (hole drilled too large). The potential effect of the failure mode for both design and process may be identical if there were no additional process related effects. In other words, the end result (effect) of the failure mode is the same, but there are two distinct causes.

While developing the PFMEA, it is the team's responsibility to ensure that all process related potential failure modes which lead to product related effects are consistent between the DFMEA and the PFMEA.

To Control Plan

In addition to the list of Recommended Actions and their subsequent follow-up as a result of the PFMEA activity, a Control Plan should be developed¹³. Some organizations may elect not to specifically identify the related product and process characteristics" in the PFMEA. In this situation, the "Product Characteristics" portion of the Control Plan may be derived from the "Requirements" portion of the "Process Function/Requirements" column and the "Process Characteristics" portion may be derived from the "Potential Cause(s) of Failure Mode" column.

When the team develops the Control Plan, they need to assure that the PFMEA current controls are consistent with the control methods specified in the Control Plan.

¹³ Guidelines for Control Plan development are included in Chrysler, Ford, GM; *Advanced Product Quality Planning and Control Plan (APQP)*, AIAG.

APPENDICES

Appendix A: Sample Forms

DFMEA Forms

- Form A: Basic form (with minimal information)¹⁴
 - With Prevention and Detection Controls as separate columns¹⁵
- Form B: Form with Item/Function and Requirements in separate columns
 - To assist in the determination of failure modes
- Form C: Form A with Prevention Controls column to the left of the Occurrence column
 - To better show the relationship between prevention controls and occurrence ranking
- Form D: Form B and C combined
- Form E: Form D with separate columns for Current Detection Design Controls (Cause and Failure Mode)
 - To highlight the need to consider cause-related controls
- Form F: Form B with separate columns for Responsibility and Target Completion Date and Actions Taken and Completion Date
 - To allow sorting by dates

¹⁴ This form was provided in the Chrysler, Ford, and GM; *FMEA Manual 3rd Edition*, AIAG.

¹⁵ Preventive and Detective Controls may be in the same column if each control is identified with a “P” or “D” respectively.

POTENTIAL
FAILURE MODE AND EFFECTS ANALYSIS
(DESIGN FMEA)

System _____ FMEA Number _____
 Subsystem _____ Page _____ of _____
 Component _____ Prepared By: _____
 Model Year(s)/Program(s) _____ Design Responsibility _____ FMEA Date (Orig.) _____
 Key Date _____
 Core Team _____

Item / Function Requirements	Potential Failure Mode	Potential Effect(s) of Failure	Severity	Classification	Potential Cause(s) of Failure	Occurrence	Current Design Controls Prevention	Current Design Controls Detection	RPN	Recommended Action	Responsibility & Target Completion Date	Action Results				
												Actions Taken & Effective Date	Severity	Occurance	Detection	RPN

DFMEA Form A

**POTENTIAL
FAILURE MODE AND EFFECTS ANALYSIS
(DESIGN FMEA)**

System _____
 Subsystem _____
 Component _____
 (Model Year(s)/Program(s)) _____
 Core Team _____

FMEA Number _____
 Page _____ of _____
 Prepared By: _____
 FMEA Date (Orig.) _____

Design Responsibility _____
 Key Date _____

Item Function	Requirements	Potential Failure Mode	Potential Effect(s) of Failure	Severity	Classification	Potential Cause(s) of Failure	Occurrence	Current Design Controls Prevention	Current Design Controls Detection	RPN	Recommended Action	Responsibility & Target Completion Date	Action Results				
													Actions Taken & Effective Date	Severity	Occurrence	Detection	RPN

DFMEA Form B

**POTENTIAL
FAILURE MODE AND EFFECTS ANALYSIS
(DESIGN FMEA)**

System: _____
 Subsystem: _____
 Component: _____
 Model Year(s)/Program(s): _____
 Core Team: _____

FMEA Number: _____
 Page _____ of _____
 Prepared By: _____
 FMEA Date (Orig.): _____

Design Responsibility: _____
 Key Date: _____

Item / Function Requirements	Potential Failure Mode	Potential Effect(s) of Failure	Severity	Classification	Potential Cause(s) of Failure	Current Design Controls Prevention	Occurrence	Current Design Controls Detection	Detection	RPN	Recommended Action	Responsibility & Target Completion Date	Action Results				
													Severity	Occurrence	Detection	RPN	

DFMEA Form C

**POTENTIAL
FAILURE MODE AND EFFECTS ANALYSIS
(DESIGN FMEA)**

System: _____
 Subsystem: _____
 Component: _____
 Model Year(s)/Program(s): _____
 Core Team: _____

FMEA Number: _____
 Page _____ of _____
 Prepared By: _____
 FMEA Date (Orig.): _____

Design Responsibility: _____
 Key Date: _____

Item Function	Requirements	Potential Failure Mode	Potential Effect(s) of Failure	Severity	Classification	Potential Cause(s) of Failure	Current Design Controls (Prevention)	Current Design Controls (Detection)	RPN	Action Results										
										Recommended Action	Responsibility & Target Completion Date	Actions Taken & Effective Date	Severity	Occurrence	Detection	RPN				

DFMEA Form D

**POTENTIAL
FAILURE MODE AND EFFECTS ANALYSIS
(DESIGN FMEA)**

System _____
 Subsystem _____
 Component _____
 Model Year(s)/Program(s) _____
 Core Team _____

FMEA Number _____
 Page _____ of _____
 Prepared By _____
 FMEA Date (Org.) _____

Design Responsibility _____
 Key Date _____

Item Function	Requirements	Potential Failure Mode	Potential Effect(s) of Failure	Severity	Classification	Potential Cause(s) of Failure	Controls Prevention	Occurrence	Current Detection Design Controls		RPN	Recommended Action	Responsibility & Target Completion Date	Action Results				
									Cause	Failure Mode				Detection	RPN	Severity	Occurrence	Detection

DFMEA Form E

**POTENTIAL
FAILURE MODE AND EFFECTS ANALYSIS
(DESIGN FMEA)**

System _____
 Subsystem _____
 Component _____
 Model Year(s)/Program(s) _____
 Core Team _____

FMEA Number _____
 Page _____ of _____
 Prepared By _____
 FMEA Date (Orig.) _____

Design Responsibility _____
 Key Date _____

Item Function	Requirements	Potential Failure Mode	Potential Effect(s) of Failure	Severity	Classification	Potential Cause(s) of Failure	Occurrence	Current Design Controls Prevention	Current Design Controls Detection	Detection	RPN	Recommended Action	Responsibility	Target Completion Date	Action Results					
															Actions Taken	Effective Date	Severity	Occurance	Detection	RPN

DFMEA Form F

PFMEA Forms

- Form A: Basic form (with minimal information)¹⁶
 - With Prevention and Detection Controls as separate columns¹⁷
- Form B: Form A with Process Step/Function and Requirements as separate columns
 - To assist in the determination of failure modes
- Form C: Form A with Prevention Controls Column to the left of the Occurrence column
 - To better show the relationship between prevention controls to occurrence ranking
- Form D: Form B and C combined
- Form E: Form D with separate columns for Current Detection Process Controls (Cause and Failure Mode)
 - To highlight the need to consider cause related controls
- Form F: Form B with separate columns for Responsibility and Target Completion Date and Actions Taken and Completion Date
 - To allow sorting by dates
- Form G: Form B with ID, Product and Process within a bridged Requirements column
 - To provide consistency among the Process Flow, PFMEA and Control Plan
- Form H: Form D and G combined

¹⁶ This form was adapted from that provided in the Chrysler, Ford, and GM; *FMEA Manual 3rd Edition*, AIAG.

¹⁷ Preventive and Detective Controls may be in the same column if each control is identified with a “P” or “D” respectively.

POTENTIAL
FAILURE MODE AND EFFECTS ANALYSIS
(PROCESS FMEA)

FMEA Number _____
Page _____ of _____
Prepared By: _____
FMEA Date (Orig.): _____

Item: _____
Model/Year(s)/Program(s): _____
Core Team: _____
Process Responsibility: _____
Key Date: _____

Process Step / Function / Requirements	Potential Failure Mode	Potential Effect(s) of Failure	Severity	Classification	Potential Cause(s) of Failure	Occurrence	Current Process Controls	Current Process Controls	RPN	Recommended Action	Responsibility & Target Completion Date	Action Results				
												Actions Taken & Effective Date	Severity	Occurrence	Detection	RPN

PFMEA Form A

**POTENTIAL
FAILURE MODE AND EFFECTS ANALYSIS
(PROCESS FMEA)**

FMEA Number _____
 Page _____ of _____
 Prepared By _____
 FMEA Date (Orig.) _____

Process Responsibility _____
 Key Date _____

Item: _____
 Model Year(s)/Program(s) _____
 Core Team _____

Process Step Function	Requirements	Potential Failure Mode	Potential Effect(s) of Failure	Severity	Classification	Potential Cause(s) of Failure	Occurrence	Current Process Controls (Prevention)	Current Process Controls (Detection)	Detection	RPN	Recommended Action	Responsibility & Target Completion Date	Action Results					
														Actions Taken & Effective Date	Severity	Occurrence	Detection	RPN	

PFMEA Form B

**POTENTIAL
FAILURE MODE AND EFFECTS ANALYSIS
(PROCESS FMEA)**

FMEA Number _____ of _____
 Page _____ of _____
 Prepared By: _____
 FMEA Date (Orig.) _____

Item: _____
 Model Year(s)/Program(s) _____
 Process Responsibility _____
 Key Date _____

Core Team: _____

Process Step / Function Requirements	Potential Failure Mode	Potential Effect(s) of Failure	Severity	Classification	Potential Cause(s) of Failure	Current Process Controls Prevention	Occurrence	Current Process Controls Detection	RPN	Recommended Action	Responsibility & Target Completion Date	Action Results								
												Actions Taken & Effective Date	Severity	Occurance	Detection	RPN				

PFMEA Form C

**POTENTIAL
FAILURE MODE AND EFFECTS ANALYSIS
(PROCESS FMEA)**

FMEA Number: _____
 Page _____ of _____
 Prepared By: _____
 FMEA Date (Orig): _____

Item: _____
 Model Year(s)/Program(s): _____
 Core Team: _____
 Process: Responsibility _____
 Key Date: _____

Process Step Function	Requirements	Potential Failure Mode	Potential Effect(s) of Failure	Severity	Classification	Potential Cause(s) of Failure	Current Process Controls Prevention	Current Process Controls Detection	RPN	Recommended Action	Responsibility & Target Completion Date	Action Results					
												Actions Taken & Effective Date	Severity	Occurrence	Detection		

PFMEA Form D

POTENTIAL
FAILURE MODE AND EFFECTS ANALYSIS
(PROCESS FMEA)

FMEA Number _____
Page _____ of _____
Prepared By: _____
FMEA Date (Orig.) _____

Item: _____
Model Year(s)/Vehicle(s) _____
Core Team _____
Process Responsibility _____
Key Date _____

Process Step Function	Requirements	Potential Failure Mode	Potential Effect(s) of Failure	Severity	Classification	Potential Cause(s) of Failure	Current Process Controls Prevention	Occurrence	Current Detection Process Controls		RPN	Recommended Action	Responsibility & Target Completion Date	Action Results				
									Cause	Failure Mode				Actions Taken & Effective Date	Severity	Occurance	Detection	RPN

PFMEA Form E

**FAILURE MODE AND EFFECTS ANALYSIS
(PROCESS FMEA)**

FMEA NUMBER: _____
 Page _____ of _____
 Prepared By: _____
 FMEA Date (Orig.): _____

Item: _____
 Model, Year(s)/Program(s): _____
 Core Team: _____
 Process Responsibility: _____
 Key Date: _____

Process Step Function	Requirements	Potential Failure Mode	Potential Effect(s) of Failure	Severity	Classification	Potential Cause(s) of Failure	Occurrence	Current Process Controls Prevention	Current Process Controls Detection	Detection	RPN	Recommended Action	Responsibility	Target Completion Date	Action Results		
															Actions Taken	Effective Date	Severity

PFMEA Form F

**POTENTIAL
FAILURE MODE AND EFFECTS ANALYSIS
(PROCESS FMEA)**

FMEA Number _____
 Page _____ of _____
 Prepared By: _____
 FMEA Date (Orig.) _____

Item: _____
 Process Responsibility: _____
 Model Year(s)/Program(s): _____
 Key Date: _____
 Core Team: _____

Process Step / Function	Requirements		Potential Failure Mode	Potential Effect(s) of Failure	Severity	Classification	Potential Cause(s) of Failure	Occurrence	Current Process Controls Prevention	Current Process Controls Detection	RPN	Recommended Action	Responsibility & Target Completion Date	Action Results						
	ID	Product / Process												Severity	Occurrence	Actions Taken & Effective Date	Severity	Occurrence	RPN	

PFMEA Form G

**POTENTIAL
FAILURE MODE AND EFFECTS ANALYSIS
(PROCESS FMEA)**

FMEA Number: _____
 Page _____ of _____
 Prepared By: _____
 FMEA Date (Orig.): _____

Item: _____ Process Responsibility: _____
 Model Year(s)/Program(s): _____ Key Date: _____
 Core Team: _____

Process Step Function	Requirements		Potential Failure Mode	Potential Effect(s) of Failure	Severity	Classification	Potential Cause(s) of Failure	Current Process Controls Prevention	Current Process Controls Detection	RPN	Recommended Action	Responsibility & Target Completion Date	Action Results				
	ID	Product Process											Actions Taken & Effective Date	Severity	Occurrence	Detection	RPN

PFMEA Form H

Appendix B: System Level FMEA

The process for a System FMEA is generally the same as the development of other FMEAs. The major differences between System level FMEAs and other types of FMEAs is the focus on functions and relationships that are unique to the system as a whole (i.e., do not exist at lower levels). The System level FMEA includes failure modes associated with interfaces and interactions in addition to considering single point failures which is the primary focus of product level FMEAs.

To help illustrate the meaning of System, Subsystem, and Component FMEAs, two examples have been constructed below in Figure B.1 (for Interfaces and Interactions) and in Figure B.2 (for Item, Function, and Failure Modes.).

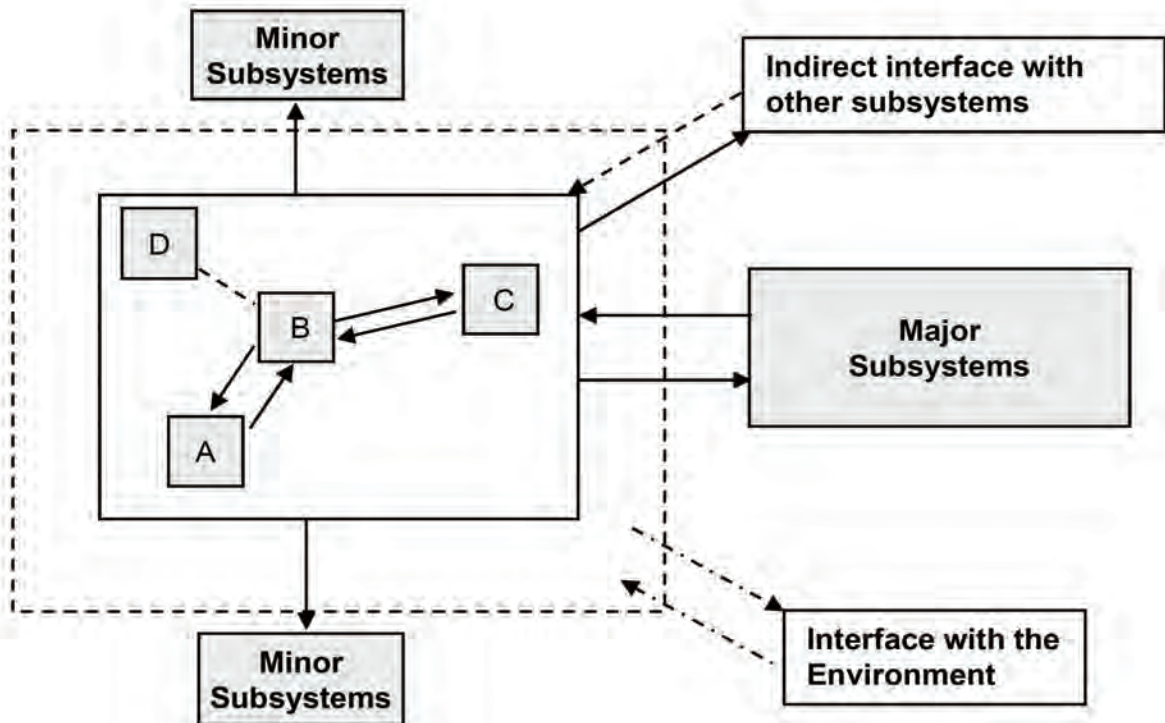

Figure B.1 Interfaces and Interactions

The FMEA team is responsible for specifying the scope of its respective FMEAs. The example in Figure B.1 shows that the team has specified Subsystems A, B, C, and D along with the surrounding environment as comprising the System that must be considered while completing the System FMEA.

Interfaces

In Figure B.1, interfaces between subsystems are shown where Subsystem A touches and (connects with) Subsystem B, B touches or connects with C, and a clearance between D and B, signified by the dashed line. The Environment also touches each of the subsystems listed in Figure B.1, which requires the “Environmental Interfaces” be considered when completing the FMEA. Also, the interfaces to major and minor subsystems, whether direct or indirect, should be included.

The interfaces which are identified in the System FMEA should be included in the respective Subsystem FMEA.

Figure B.2 shows a system and its interrelationships in a “hardware” oriented approach.

Interactions

A change in one subsystem or component may cause a change in another subsystem or component.

In Figure B.1, interactions between subsystems and components can occur among any of the interfacing systems. For example, Subsystem A heats up, resulting in Subsystem B and D gaining heat through their respective interfaces, as well as Subsystem A giving off heat to the environment. Interactions might also occur among ‘non-contacting’ systems via transfer through the ‘environment’. For example, if the environment is composed of high humidity and Subsystems A and C are dissimilar metals separated by a non-metal composing Subsystem B, Subsystem A and C can still have an electrolytic reaction due to the moisture from the environment. Thus, interactions among non-contacting subsystems can be relatively difficult to predict but are important and should be considered.

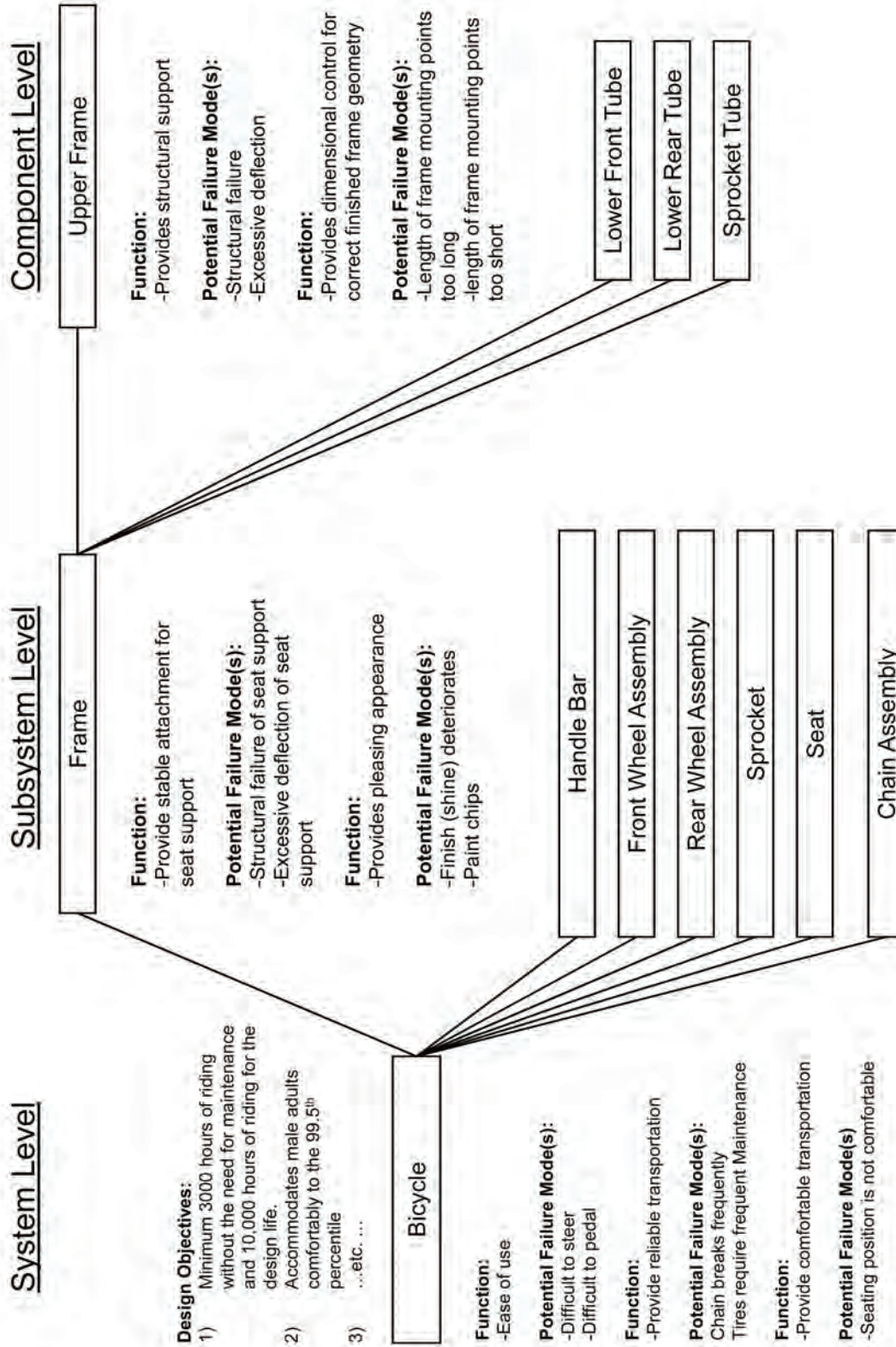

Figure B.2 Item, Functions, and Failure

Relationships

Multiple Levels of Design FMEAs

More likely than not, the focus of a DFMEA is an item which is a subset of a larger system. The FMEAs at the different levels of the design hierarchy (i.e., system, subsystem and component) are linked through the cause → failure mode → effect of failure relationships. This is a two way linkage (see Figure B.3):

From Lower to Higher Level: The effect of a failure mode at a given level is a failure mode at the next higher level.

For example, the effect of a part 2 failure mode would be a failure mode of module 3 either directly or indirectly by causing another part to fail. The effect of a module 4 failure mode is a failure mode of subsystem 4. Consequently, the effect of a failure mode at any sublevel may ultimately become a system failure mode with its customer / user related effects.

From Higher to Lower level: The linkage from a higher level to the next lower level is related to the physics of failure rather than a pure cause and effect relationship since in the development of a DFMEA, the causes identified at any level deal with the design process and only indirectly with the failure mechanisms.

Understanding these relationships will provide a consistency of analysis and an economy of effort in the development of DFMEAs.

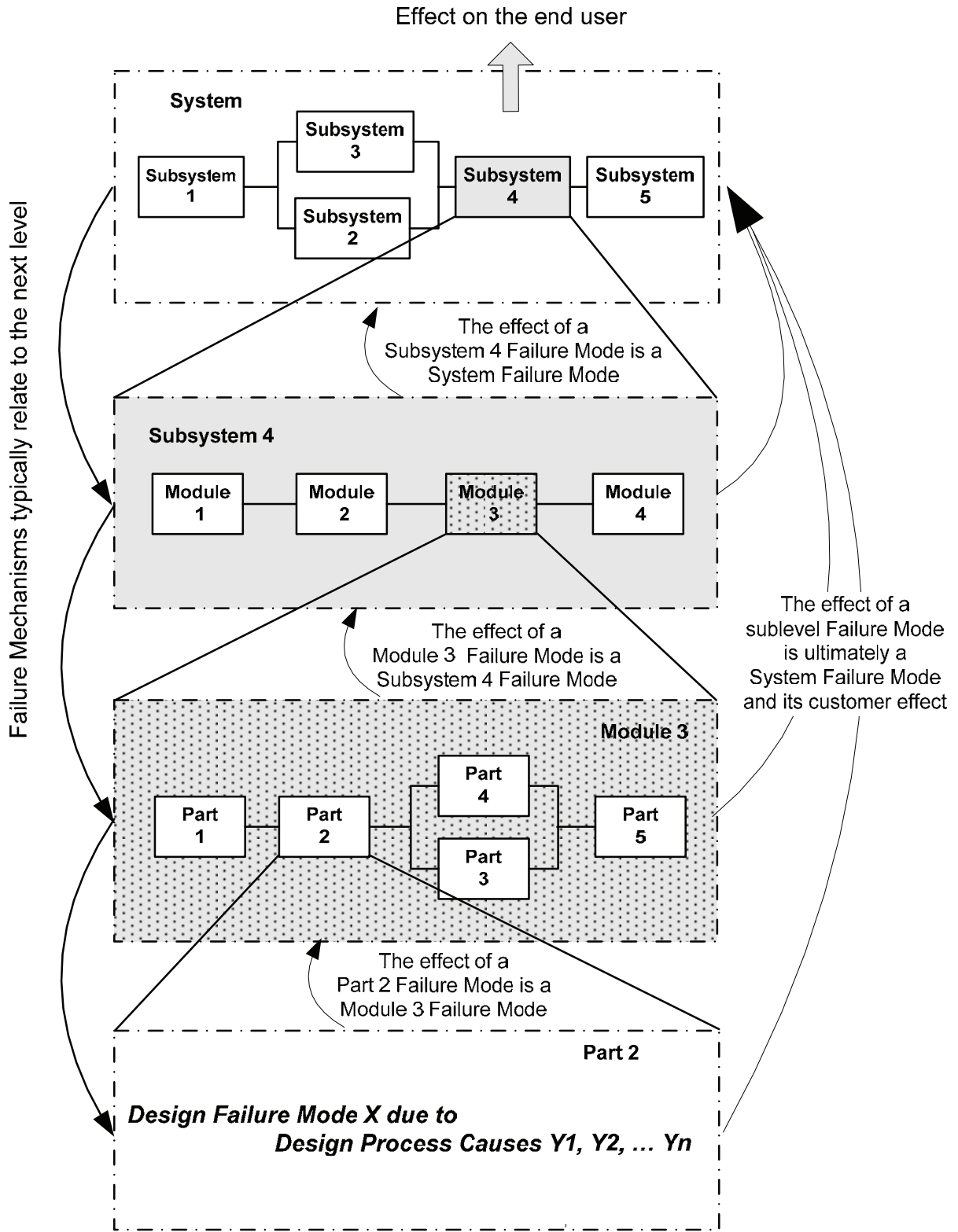

Figure B.3 DFMEA Effects Linkages

Appendix C: Alternative Risk Assessments

Alternatives to RPN

The risk priority number is the product of the severity (S), occurrence (O), and detection (D) rankings.

$$(S) \times (O) \times (D) = RPN$$

Within the scope of the individual FMEA, this value (between 1 and 1000) can be used to assist the team in ranking the concerns in the design of the product and process.

The table below, however, illustrates how *different* Severity (S), Occurrence (O) & Detection (D) scenarios result in *equal* RPN values.¹⁸

Upon review of each scenario, priorities would not be established by the team based on the RPN alone.

Fifteen Different Situations with an RPN=360

	Severity of Problem		Likelihood of Occurrence		Likelihood of Detection	
1	Hazardous	10	High	9	Moderate	4
2	Hazardous	10	Moderate	6	Low	6
3	Hazardous	10	Moderate	4	Very Remote	9
4	Hazardous	9	Very High	10	Mod High	4
5	Hazardous	9	High	8	Moderate	5
6	Hazardous	9	Moderate	5	Remote	8
7	Hazardous	9	Moderate	4	Impossible	10
8	High	8	High	9	Moderate	5
9	High	8	Moderate	5	Very Remote	9
10	Moderate	6	Very High	10	Low	6
11	Moderate	6	Moderate	6	Impossible	10
12	Moderate	5	High	9	Remote	8
13	Moderate	5	High	8	Very Remote	9
14	Moderate	4	Very High	10	Very Remote	9
15	Moderate	4	High	9	Impossible	10

The ease of calculation and sorting of this index has led many to use it exclusively and without consideration to what may be a more appropriate means of prioritizing. Examples of some such alternatives follow.

¹⁸ Used with permission from Whirlpool Corporation, ©2005, 2006

Alternative: SO (S x O)

Some organizations may choose to primarily focus on Severity and Occurrence. The SO index is the product of the Severity, and Occurrence rankings. In using this index, the organization may focus on how to reduce SO by reducing the value of “O” through preventive actions. Furthermore this may lead to subsequent detection improvements for those with the highest SO value.

Alternative: SOD, SD

Some organizations have chosen to use SOD or SD as a prioritization tool. SOD is the non-arithmetic combination of the Severity, Occurrence and Detection rankings. SD is the non-arithmetic combination of the Severity and Detection rankings.

Example (SOD):

Severity, $S = 7$

Occurrence, $O = 3$

Detection, $D = 5$

The resulting SOD is 735

Example (SD):

Severity, $S = 7$

Detection, $D = 5$

The resulting SD is 75

The SOD, when sorted in numerical, descending order, will prioritize the scenarios first by severity, second by occurrence and lastly by detection.

S	O	D	RPN	SOD	SD
7	7	3	147	773	73
7	3	7	147	737	77
3	7	7	147	377	37

} Very Different Scenarios

Equal RPN Values

Table C.1 Contrast among RPN, SOD and SD

Just as with RPN, use of the SOD/SD index should be used in context of team discussion. Defining priorities simply based on the SOD has limitations just as with the RPN. For example, a failure mode with a SOD of 711 would be ranked higher (i.e., have to be considered before) a failure mode with 599.

Appendix D: Alternative Analyses Techniques

Failure Mode and Effects Analysis is one of many techniques used to evaluate and analyze design risk. Other methods have been developed for specific areas and can be used to complement the analysis in the FMEA process. They may be used as a replacement for an FMEA with authorization by the customer. These are only a few of the examples.

Failure Mode, Effect and Criticality Analysis (FMECA)

FMECA is similar to FMEA. The C in FMECA indicates that the criticality (or severity) of the various failure effects are considered and ranked. Today, FMEA is often used as a synonym for FMECA.

Design Review Based on Failure Modes (DRBFM)

Design Review Based on Failure Modes is a cause and effect analysis of concerns related to a design change. It is a tool used to guide and manage good discussion in relation to the change. DRBFM focuses on the impact of the change on design, evaluation procedures, and manufacturing systems with the intent of anticipating and preventing problems. A design review by subject matter experts to evaluate the change(s) and related improvements is an integral part of DRBFM. (Reference Figure D.1).

Fault Tree Analysis (FTA)

FTA is a technique for system analysis where system faults are analyzed from a single potential failure to identify all possible causes. FTA considers combinations of interdependent as well as independent causes. In addition to the structure of the fault tree and all of the logic interdependencies, the FTA normally includes the failure probabilities identification. This allows the calculation of system reliability given the component reliabilities.¹⁹ (Reference Figure D.2).

¹⁹ References: IEC 61025; QICID (ASQ-20352).

Design Review Based on Failure Mode - DRBFM		Action Status					
		Recommended Actions per review (Based on Potential Failure Mode)	Responsibility & Target Completion Date			R	
			Manufacturing			R	
			Responsibility & Target Completion Date			R	
			Evaluation			R	
			Responsibility & Target Completion Date			R	
			Design			R	
		Design Actions to eliminate concerns (provide details and best practices used)			D		
		Potential Effect on Customer	Severity			R	
			Effect Code		D	R	
Customer and System or Subsystem Effect			D	R			
Potential Cause of Fw/Concern	Other Causes (Review)			R			
			D	R			
Concerns related to the change	Other Concerns (Review)			R			
	Loss of Function or Value to Customer		D				
Part Function			D				
Change to Design or Environment			D				

D = Design Responsible Input R = Team Review

Figure D.1 Example of DRBFM Elements

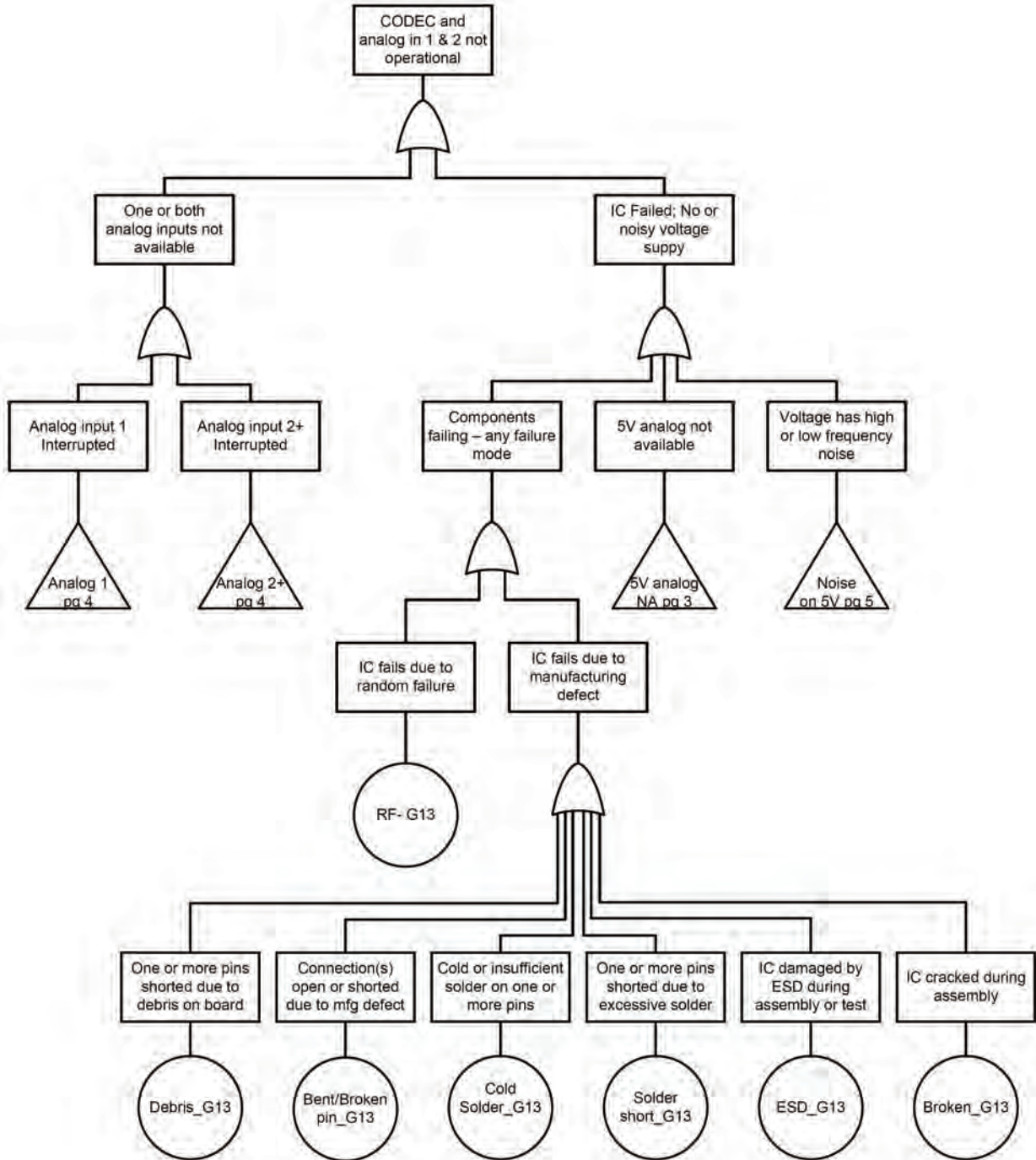

Figure D.2 FTA Tree Structure

References and Suggested Readings

- IEC 60300-3-1, *Dependability management – Part 3-1: Application guide – Analysis techniques for dependability – Guide on methodology*.
- IEC 60812, Edition 2; *Failure modes and effects analysis*, January 2006.
- IEC 61025, Edition 2; *Fault tree analysis*, January 2007.
- QICID (ASQ-20352) “*System Reliability Through Fault Tree Analysis*”.
- SAE ARP 5580, *Recommended Failure Modes and Effects Analysis (FMEA). Practices for Non-Automotive Applications*. (Replacement for MIL-STD-1629A, 1998 (withdrawn)).
- SAE J1739:2002, *Potential Failure Mode and Effects Analysis in Design (Design FMEA) and Potential Failure Mode and Effects Analysis in Manufacturing and Assembly Processes (Process FMEA)*.
- Alfredo, H.S. Ang and Wilson, H. Tang (1990). “*Probability Concepts in Engineering Planning and Design, Volume II -- Decision Risk and Reliability*”, Wiley Publications.
- Bowles, J. (2003). “An Assessment of RPN Prioritization in a Failure Modes Effects and Criticality Analysis”, *Proceedings Annual Reliability and Maintainability Symposium*, pp 380-386; also in *Journal of the IEST, Institute of Environmental Sciences and Technology*, Vol 47, 2004, pp. 51-56.
- Krasich, M. (2007). “Physics of Failure Approach to FMEA”, *Tutorial Proceedings Reliability and Maintainability Symposium*.
- Krasich, M. (2005). “Fault Tree Analysis in Product Reliability Improvement”, *Tutorial Proceedings Reliability and Maintainability Symposium*.
- O’Conner, P.D.T., (2002). *Practical Reliability Engineering*. 4th edition, (Wiley).
- Shu-Ho Dai and Ming-O Wang (1992), *Reliability Analysis in Engineering Applications*, Van Nostrand Reinhold.
- Wheeler, D. J. (2005). *The Six Sigma Practitioner's Guide to Data Analysis*, SPC Press, Knoxville, pp.311-315.
- Rausand, M. (2004). *System Reliability Theory* (2nd ed), Wiley, 2004.

Index

- APQP (Advanced Product Quality Planning), 2, 5
- block diagram, 18, 19, 29
- classification, 39, 91
- continuous improvement, 6, 57, 63, 103, 107, 109
- control plans, 6, 13, 111
- cross-functional, 2, 9, 17, 69, 71
- current design controls, 49, 53
- design improvements, 16
- design intent, 11, 12, 22, 29, 41, 49, 68, 79
- design life, 45
- detection, 13, 18, 49, 51, 57-64, 68, 73, 95, 99-110, 135, 136
- detection controls, 49, 66, 99, 107
- DFMEA (Design Failure Mode and Effects Analysis), 5, 16-19, 22, 25, 29, 39, 41, 64-66, 70, 73, 83, 84, 111, 133
- DOE (Design of Experiments), 61, 107
- DRBFM (Design Review by Failure Mode), 137, error proofing, 73, 105
- evaluation criteria, 37, 45, 53, 87, 92, 99
- flow diagram, 70, 71, 81, 107
- FMECA (Failure Mode, Effect and Critical Analysis), 3, 137
- Follow-up, 6
- FTA (Fault Tree Analysis), 137, 139
- function, 16, 18, 19, 21, 29, 31, 35, 71, 79, 111
- functional requirements, 8, 16, 18, 25
- interactions, 3, 10, 130, 131
- interfaces, 10, 11, 29, 130, 131
- item, 73, 75, 111, 133
- linkages, 65, 111, 134
- mistake proofing, 61, 107
- occurrence, 3, 13, 45, 46, 49, 53, 57, 59, 61, 63, 64, 68, 69, 92, 93, 95, 99, 103, 105, 107, 109, 110, 135, 136
- OEM (GM, Ford, Chrysler), 11, 17, 27, 75
- PFMEA (Process Failure Mode and Effects Analysis), 5, 17, 66, 68-71, 75, 77, 83, 91, 95, 110, 111
- potential cause, 12, 39, 41, 91, 92
- potential failure mode, 11, 16-18, 31, 61, 70-71, 81, 112
- preventive controls, 45
- process step, 77, 79, 107
- recommended actions, 6, 13, 18, 57, 59, 61, 103, 107
- responsible engineer, 17, 63, 69, 70, 91, 107
- RPN (Risk Priority Number), 57, 59, 63, 103, 105, 109, 135, 136
- scope, 3, 4, 8, 10, 11, 18, 25, 68, 70, 71, 73, 75, 130
- SD (Ranking by Severity and Detection), 136
- Severity, 13, 37, 57, 59, 63, 84, 87, 103, 109, 135, 136
- SO (Ranking by Severity and Occurrence), 136
- SOD (Ranking based on Severity, Occurrence and Detection), 136
- SPC (Statistical Process Control), 95, 107
- special characteristic, 39, 91
- specification, 11, 13, 61, 107
- team, 2, 4, 5, 8, 9, 10, 14, 17, 18, 21, 22, 27, 29, 35, 37, 41, 45, 49, 53, 57, 59, 69, 71, 73, 81, 87, 91, 95, 99, 103, 105, 111
- team leader, 6, 9, 69, 70, 107
- thresholds, 57, 59, 103, 105
- validation, 16, 31, 49, 59, 61

