

Breaking and protection devices

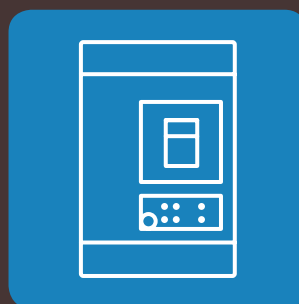

05

POWER GUIDE 2009 / BOOK 05

INTRO

The purpose of selecting a protection device is to perform two essential functions: to protect people and to protect trunking, while ensuring the best possible continuity of service. On the other hand, the role of a breaking device (isolation, functional breaking, emergency breaking) is to control the various circuits without providing protection on its own.

The purpose of the protection of trunking is to limit the effects of overloads and short circuits (see the book 4 “Sizing conductors and protection devices”). People are protected against indirect contact according to the neutral earthing system and the characteristics of the installation (see the book 6 “Electrical hazards and protecting people”).

Legrand equipment covers all requirements for breaking and LV protection:

- DMX³ air circuit breakers and switches for high-power LV main distribution boards (up to 4000 A)
- DPX moulded case circuit breakers and switches (16 to 1600 A)
- DPX-IS and Vistop load break switches
- DX modular circuit breakers for protecting terminal circuits
- Residual current circuit breakers and switches, and adaptable earth leakage modules for the protection of people
- Voltage surge protectors to protect equipment against overvoltages

A wide range of characteristics, technologies and accessories are available to meet all requirements.

Circuit breakers	04
Technologies used	04
Characteristics of circuit breakers	06
Tripping curves	08
Limitation	10
DMX³ air circuit breakers	12
The DMX ³ range	12
Technical characteristics	14
Electronic protection units	16
Communication and supervision	20
Accessories	21
Connecting DMX ³	24
Supply inverters	26
Performance data and limitation curves	30
Dimensions	34
DMX-E air circuit breakers	44
The DMX-E range	44
Electronic trip units	45
Technical characteristics	46
Control accessories	47
Signalling contacts	48
Padlocking and mechanical accessories	49
Supply inverters	49
Connection	50
Tripping curve	51
Dimensions	52

DPX moulded case circuit breakers	54
The DPX range	54
Characteristics	56
Releases	58
Mounting, accessories and connection of DPX	60
Adaptable electronic earth leakage modules	69
Special applications and derating	70
Performance data	72
Limitation curves	74
Dimensions	76
DRX moulded case circuit breakers	90
The DRX range	90
Technical characteristics	91
Lexic DX modular circuit breakers	94
The Lexic DX modular range	94
Characteristics of DX circuit breakers	96
Auxiliaries and motor-driven controls for DX	98
Connecting DX	99
Choice of protection devices according to the neutral earthing system	100
Special applications and derating	101
Performance data	103
Thermal stress limitation curves	104
Current limitation curves	108
DX-E modular circuit breakers	110
LR modular circuit breakers	112
Legrand isolating switches	114
Isolating switches with positive contact indication	114
Isolating switches with visible contact indication	115
Trip-free isolating switches	121

Fuses	122
Fuse technology	122
Fuse characteristics	124
SPX fuse carriers and fused isolating switches	130
SPX range	130
Technical characteristics	131
Connection capacity	133
Dimensions	134
Back-up protection	138
Back-up between ACBs and MCCBs	139
Back-up between MCCBs and MCBs	140
Back-up between fuse cartridges and MCBs	142
Back-up between circuit breakers and switches	142
Selectivity between protection devices	144
Current sensing selectivity	145
Time selectivity	146
Dynamic selectivity	146
Logical selectivity	148
Selectivity Tables (3-phase network 400/415 V AC)	152
Choice of products	160
DMX ³ ACBs and DMX ³ -I trip-free switches	160
DMX-E air circuit breakers	162
DPX circuit breakers and DPX-I trip-free switches	164
DRX circuit breakers	168
DX Lexic MCBs, RCDs and RCBOs	169
DX-E MCBs	174
LR MCBs and RCDs	174
DPX-IS and VISTOP isolating switches	175
SP fuse carriers and cylindrical cartridge fuses	176
Base, SPX and blade type cartridge fuses	178

Circuit breakers

A circuit breaker is both a circuit-breaking device that can make, withstand and break currents whose intensity is at most equal to its rated current (I_n), and a protection device that can automatically break overcurrents which generally occur following faults in installations. The choice of a circuit breaker and its characteristics depends on the size of the installation.

TECHNOLOGIES USED

Overcurrents are detected by three different devices: thermal for overloads, magnetic for short circuits and electronic for both. Thermal and magnetic releases, which are generally combined (thermal-magnetic circuit breakers), use an economical, tried and tested technology, but provide less flexibility of adjustment than electronic releases.



Legrand circuit breakers also perform the following functions:

- Manual or automatic control of a circuit
- Isolation with positive contact indication
- Isolation with visible contact operation for plug-in or draw-out devices
- Emergency breaking
- Residual current protection
- Undervoltage protection



Product standards Installation standards

It is important to distinguish between these two types of standard: the former concern the equipment, and are the responsibility of the manufacturers, while the latter concern installation, and ensure the correct operation, safety and durability of installations. Installation standards are compulsory by law. Installers must apply them, but beyond that they must also ensure the overall performance of the installation (from the main LV distribution board to the socket) based on the product quality and guarantees that only a major manufacturer can provide.

1 THERMAL RELEASE

This consists of a bi-metal strip which, if heated beyond the normal operating values, becomes deformed, releasing the lock holding the contacts. The reaction time of a bi-metal strip is inversely proportional to the intensity of the current. As a result of its thermal inertia, the bi-metal strip reacts faster when a second overload follows the first in quick succession. This improves the protection of the cables, the temperature of which is already higher. DPX circuit breakers enable the trip current I_r to be set between certain limits (0.4 to 1 I_n depending on the model).

2 MAGNETIC RELEASE

This consists of a magnetic loop whose effect releases the lock holding the contacts, thus triggering breaking if there is a high overcurrent. The response time is very short (around one tenth of a second). DPX moulded case circuit breakers have an I_m setting (up to $10 \times I_r$), which can be used to set the trip value to the protection conditions of the installation (fault current and indirect contact). Moreover this setting, when combined with a time delay, can be used to find the best discrimination conditions between the devices.

3 ELECTRONIC RELEASE

A coil, placed on each conductor, continuously measures the current in each of them. This information is processed by an electronic module which controls the tripping of the circuit breaker when the values of the settings are exceeded. The curve of the release shows three operating zones.

- **“Instantaneous” operating zone**

This provides protection against high intensity short circuits. It is either set by construction at a fixed value (5 to 20 kA), or adjustable according to the device.

- **“Short delay” operating zone**

This provides protection against lower intensity short circuits, which generally occur at the end of the line. The trip threshold is generally adjustable. The period of the delay may be increased by thresholds up to one second, to ensure discrimination with devices placed downstream.

- **“Long delay” operating zone**

This is similar to the characteristic of a thermal release. It protects conductors against overloads. The electronic releases available on DMX and DPX improve the discrimination and make the devices able to communicate.

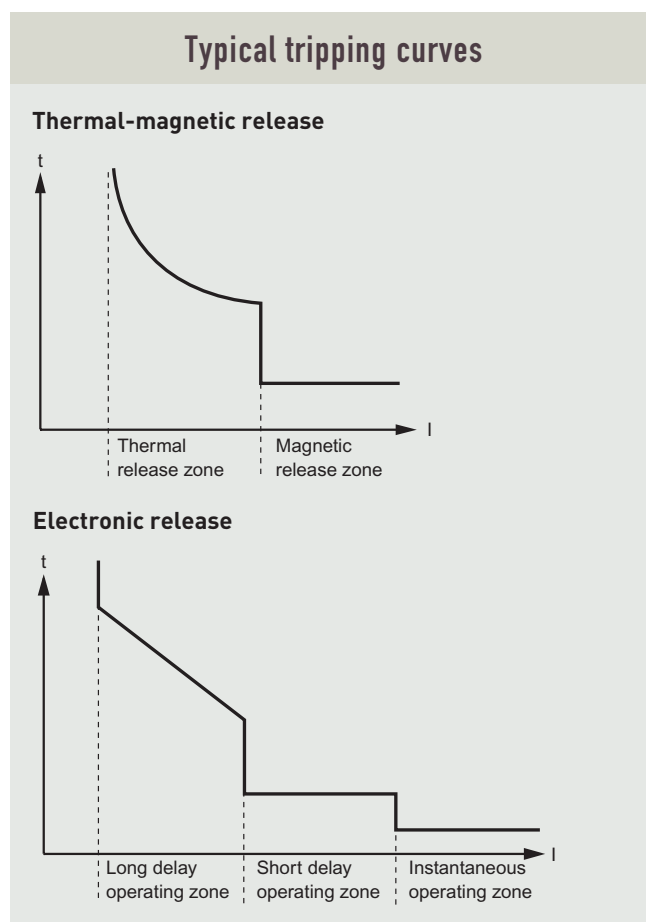

Electric arc

The current is broken in the circuit breaker arc chamber, which is designed to control the electric arc produced when the contacts open (rather like electrodes). The arc energy can become considerable, up to 100 kilojoules and 20 000°C, and can cause the contacts to be eroded by vaporisation of the metal.

It is therefore a good idea to extinguish the arc as quickly as possible, in order to limit its effects. The magnetic field produced by the arc (which is a conductor) is used to move it into an “arc chamber” and extend it until it has been extinguished.

The circuit breaker mechanisms must combine very fast opening of the contacts (limiting erosion) and high contact pressure (opposition to the electrodynamic forces).

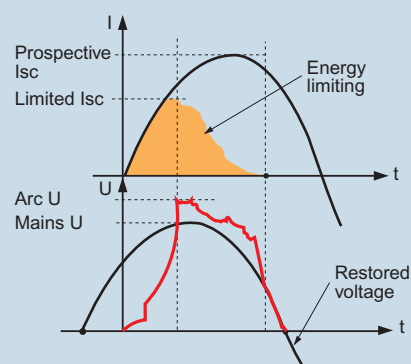

Circuit breakers (continued)

CHARACTERISTICS OF CIRCUIT BREAKERS

1 RATED OPERATING VOLTAGE U_e (in V)

This is the voltage(s) at which the circuit breaker can be used. The value indicated is usually the maximum value. At lower voltages, certain characteristics may differ, or even be improved, such as the breaking capacity.

2 INSULATION VOLTAGE U_i (in V)

This value acts as a reference for the insulation performance of the device. The insulation test voltages (impulse, industrial frequency, etc.) are determined based on this value.

3 IMPULSE VOLTAGE U_{imp} (in kV)

This value characterises the ability of the device to withstand transient overvoltages such as lightning (standard impulse 1.2/50 μ s).

4 UTILIZATION CATEGORY

IEC 60947-2 designates circuit breakers as belonging to one of two categories:

- Category A for circuit breakers which do not have a time delay before tripping on a short circuit
- Category B for circuit breakers which have a time delay. This can be adjusted in order to perform time discrimination for a short-circuit value less than I_{cw} . The value of I_{cw} must be at least equal to the larger of the two values, $12 I_n$ or 5 kA, for circuit breakers with a rated current of 2500 A at most, and 30 kA thereafter.

5 RATED CURRENT I_n (in A)

This is the maximum current value the circuit breaker can withstand on a permanent basis.

This value is always given for an ambient temperature around the device of 40°C in accordance with standard IEC 60947-2, and 30°C in accordance with standard IEC 60898-1.

If this temperature is higher, it may be necessary to reduce the operating current.

6 ULTIMATE BREAKING CAPACITY I_{cu} (in kA)

This is the maximum short-circuit current value that a circuit breaker can break at a given voltage and phase angle ($\cos \varphi$). The tests are executed according to the sequence O - t - CO. O represents an automatic break operation, t a time interval and CO a make operation followed by an automatic break operation. Following the test, the circuit breaker must continue to provide a minimum level of safety (isolation, dielectric strength).

7 NOMINAL BREAKING CAPACITY I_{cn} (in A)

In standard IEC 60898-1, the breaking capacity of the device is tested in a similar way but is called I_{cn} . After the test, the circuit breaker must retain its dielectric properties and be able to trip in accordance with the specifications in the standard.



Circuit breakers are often identified with two breaking capacities.

This distinction is the result of standards using different test conditions.

- **10 000**: standard IEC 60898-1 for household or similar applications where unqualified people can re-close a circuit with a persistent fault several times. The breaking capacity (in Amps) appears in a box, with no mention of the unit.

- **10 kA**: standard IEC 60947-2 for all applications where those who work on them are qualified. The breaking capacity then appears together with its unit.

8 STANDARD BREAKING CAPACITY I_{cs}

This is the value expressed as a percentage of I_{cu} . It will be one of the following values: 25% (category A only), 50%, 75% or 100%. The circuit breaker must be capable of operating normally after breaking the I_{cs} current several times using the sequence O-CO-CO. Standard IEC 60898 gives the minimum values to be reached according to the I_{cn} of the device.



During operation, it is very rare that a circuit breaker has to break the maximum prospective short-circuit current (which was used to determine its required breaking capacity). However, it may have to break lower currents. If they are lower than the I_{cs} of the device, this means that the installation can be restarted immediately after the break. It should be noted that to date very few specifications or installation standards have made any reference to the I_{cs} .

9 SHORT-TIME WITHSTAND CURRENT I_{cw} (in kA)

This is the value of the short-circuit current that a category B circuit breaker is capable of withstanding for a defined period without altering its characteristics. This value is intended to enable discrimination between devices. The circuit breaker concerned can remain closed while the fault is eliminated by the downstream device as long as the energy I^2t does not exceed I_{cw}^2 (1 s).



By convention the value I_{cw} is given for a time $t = 1$ s. For a different duration t , this must be indicated, for example $I_{cw0.2}$. It is then necessary to check that the thermal stress I^2t , generated until the downstream device breaks, is actually less than I_{cw}^2t .

10 RATED SHORT-CIRCUIT MAKING CAPACITY I_{cm} (kA peak)

This is the maximum current intensity a device can make at its rated voltage according to the conditions of the standard. Devices without a protection function, such as switches, must be able to withstand short-circuit currents with a value and duration resulting from the action of the associated protection device.



Product standards

- **Standard IEC 60898-1**
In practice, reference is made to this standard for the terminal circuits of household, residential and small business installations, where those involved are not qualified. It applies up to 125 A, 25 000 A breaking capacity and 440 V. Thermal tripping takes place between 1.13 and 1.45 In. It determines operating ranges, such as B, C, D, etc. for magnetic tripping. Products complying with standard IEC 60898 can also be used in industrial installations as far as their characteristics permit.
- **Standard IEC 60947-2**
This standard is used in industry, and assumes that those involved are qualified. It does define an operating range: all characteristics (I_r , I_m , t , etc.) can be adjusted.
Legrand DX circuit breakers comply with both standards.
- **Standard IEC 61009-1**
This applies to circuit breakers with a residual current function.
- **Standard IEC 61008-1**
This applies to residual current circuit breakers.

Circuit breakers (continued)

TRIPPING CURVES

Examples of tripping curves

DPX 250 circuit breaker with thermal-magnetic release

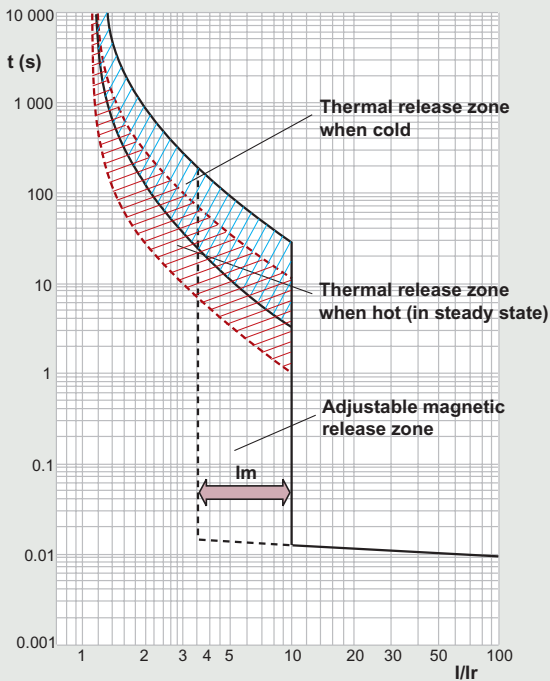

- I:** actual current
- Ir:** thermal protection against overloads (Ir setting = $x I_n$)
- Im:** magnetic protection against short circuits: (Im setting = $x I_r$)

Since the abscissa of the curves expresses the I/I_r ratio, modifying the I_r setting does not change the graphic representation of thermal tripping. However, the magnetic setting I_m can be read directly (3.5 to 10 in this example).

DPX-H 1600 circuit breaker with electronic release

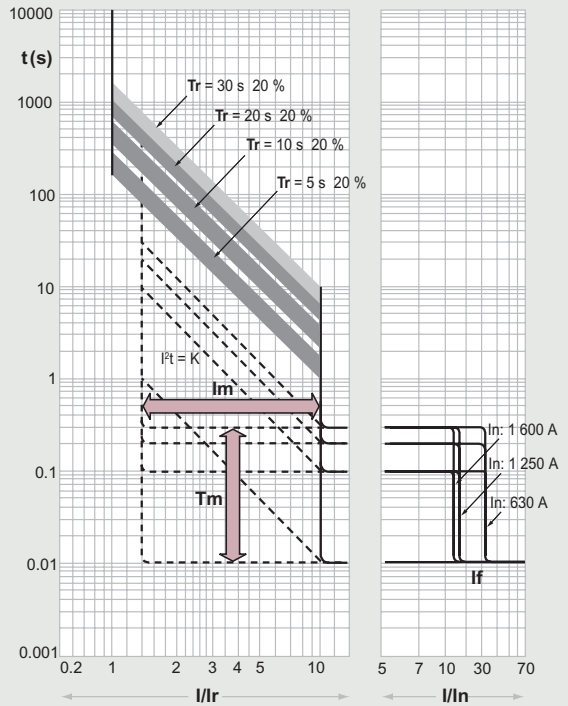

- I:** actual current
- Ir:** long delay protection against overloads (adjustable: $I_r = x I_n$, 0.4 to $1 x I_n$)
- Tr:** long delay protection operation time (adjustable: 5 to 30 s) up to $6 x I_r$
- Im:** short delay protection against short circuits (adjustable: $I_m = x I_r$, 1.5 to $10 I_r$)
- Tm:** short delay protection operation time (adjustable: 0 to 0.3 s)
- I^2t constant:** (adjustable via T_m) see p. 146
- If:** fixed threshold instantaneous protection (fixed: 5 to 20 kA depending on the model)

Example of setting a circuit breaker and reading the curves

Here: $I_B = 500 \text{ A}$ and $I_{k3_{max}} = 25 \text{ kA}$ at the installation point.
 Protection can then be provided by an electronic DPX 630,
 rating 630 A (Cat. No. 256 03/07),
 long delay setting (overload) $I_r = 0.8 \times I_n$, i.e. 504 A

Scenario 1: High min. Isc

Isc min. (at end of line) = 20 kA
 \Rightarrow short delay setting (short circuit) $I_m = 10 \times I_r$,
 i.e. 5040 A

Reading the curves:

If $I < 504 \text{ A} \Rightarrow$ no tripping

If $504 \text{ A} \leq I < 5 \text{ kA} \Rightarrow$ tripping between 1 and 200 s
 (long delay protection)

If $I > 5 \text{ kA} \Rightarrow$ tripping in 0.01 s

(fixed threshold instantaneous protection)

Scenario 2: Low min. Isc

Isc min. (at end of line) = 4 kA
 \Rightarrow short delay setting (short circuit) $I_m = 5 \times I_r$,
 i.e. 2520 A

Reading the curves:

If $I < 504 \text{ A} \Rightarrow$ no tripping

If $504 \text{ A} \leq I < 2520 \text{ A} \Rightarrow$ tripping between 6 and 200 s
 (long delay protection)

If $2520 \text{ A} \leq I < 5 \text{ kA} \Rightarrow$ tripping $< 0.1 \text{ s}$
 (short delay protection)

If $I > 5 \text{ kA} \Rightarrow$ tripping in 0.01 s

(fixed threshold instantaneous protection)

Scenario 3: Cable thermal stress limited

Isc min. (at end of line) = 20 kA
 Conductor 10 mm^2 , permissible thermal stress:
 $1.32 \times 10^6 \text{ A}^2\text{s}$, i.e. 3633 A for 0.1 s
 \Rightarrow short delay setting (short circuit) $I_m = 7 \times I_r$,
 i.e. 3528 A ($< I_{th}$ of the cable)

Reading the curves:

If $I < 504 \text{ A} \Rightarrow$ no tripping

If $504 \text{ A} \leq I < 3528 \text{ A} \Rightarrow$ tripping between 3 and 200 s
 (long delay protection)

If $3528 \text{ A} \leq I < 5 \text{ kA} \Rightarrow$ tripping $< 0.1 \text{ s}$
 (short delay protection)

If $I > 5 \text{ kA} \Rightarrow$ tripping in 0.01 s

(fixed threshold instantaneous protection)

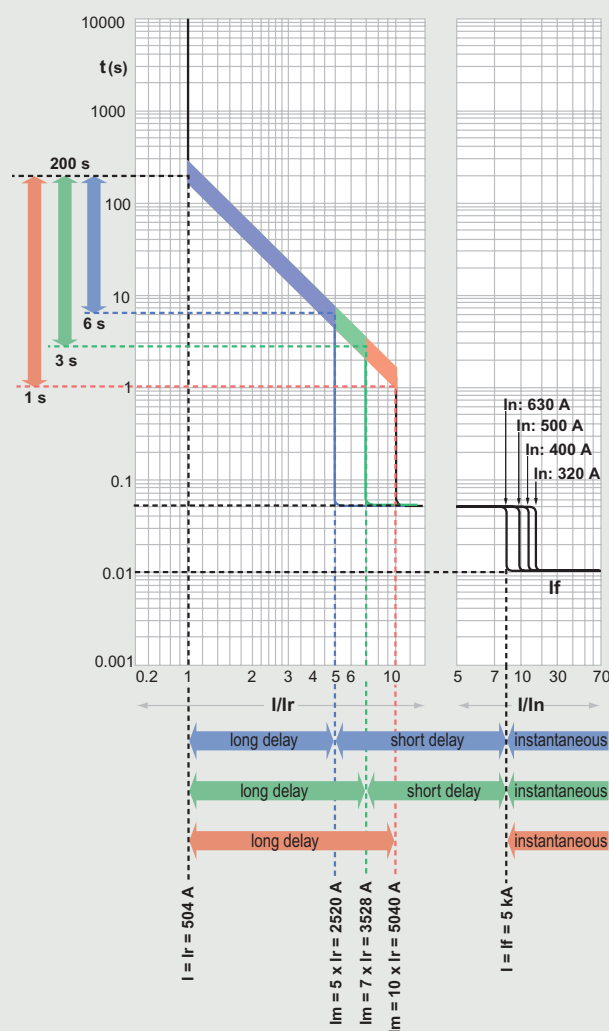

Circuit breakers (continued)

For secondary circuit breakers, standard IEC 60898-1 specifies the limits within which tripping on short circuits should take place:

- Curve B: 3 to 5 I_n
- Curve C: 5 to 10 I_n
- Curve D: 10 to 20 I_n

Other types of curve can also be used:

- Curve Z: 2.4 to 3.6 I_n
- Curve MA: 12 to 14 I_n

! As a general rule, curve C circuit breakers are used for standard distribution applications. It may be necessary to use curve B circuit breakers for low short-circuit currents (long cables, secondary circuit breaker in IT or TN system, alternator, etc.). If there are high inrush currents (transformers, motors), curve D avoids false tripping, in particular on starting. Curve Z (high sensitivity) is generally reserved for protecting circuits supplying electronic equipment. MA (magnetic only) circuit breakers are used for circuits where thermal protection is prohibited or provided by other methods: safety circuits in public buildings, motor circuits, transformers, etc.

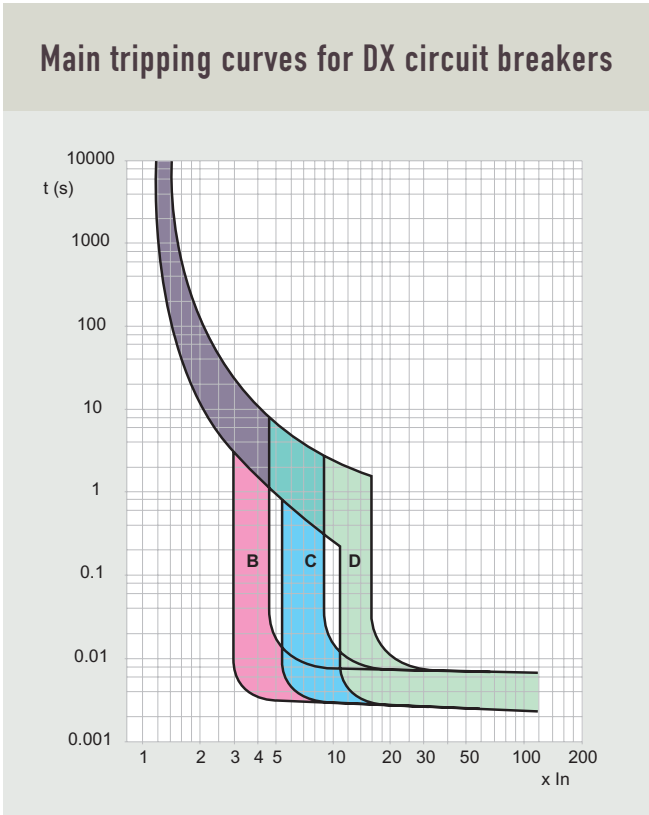

LIMITATION

If there is a short circuit, without any protection, the current that would flow through the installation is the prospective short-circuit current. When a short-circuit current crosses a circuit breaker, the circuit breaker has the capacity, to a greater or lesser extent, to allow only part of this current to flow. The short circuit is then limited in amplitude and duration. The purpose of limitation is to reduce:

- Thermal stress
- Electrodynamic forces
- Effects of electromagnetic induction

It also makes discrimination and combination easier. The limitation capacity of devices is represented in the form of limitation curves.

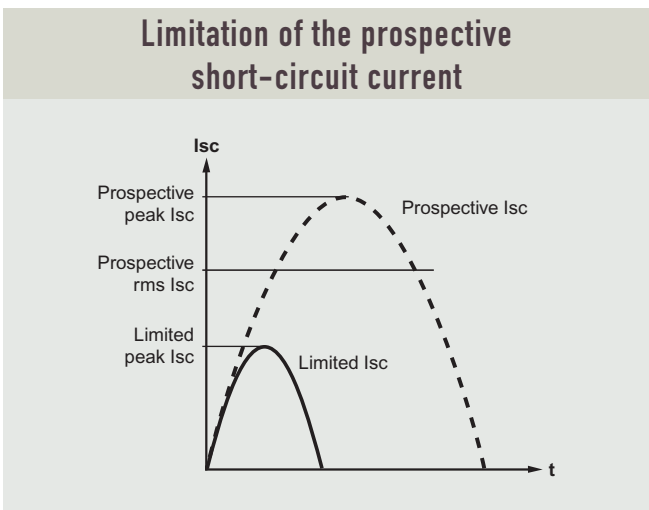

1 CURRENT LIMITATION CURVES

These give the maximum peak current values (in A peak), limited by the devices according to the value of the prospective short-circuit current. The limited current values are used to determine the size of the busbars and to check the withstand of conductors and devices.

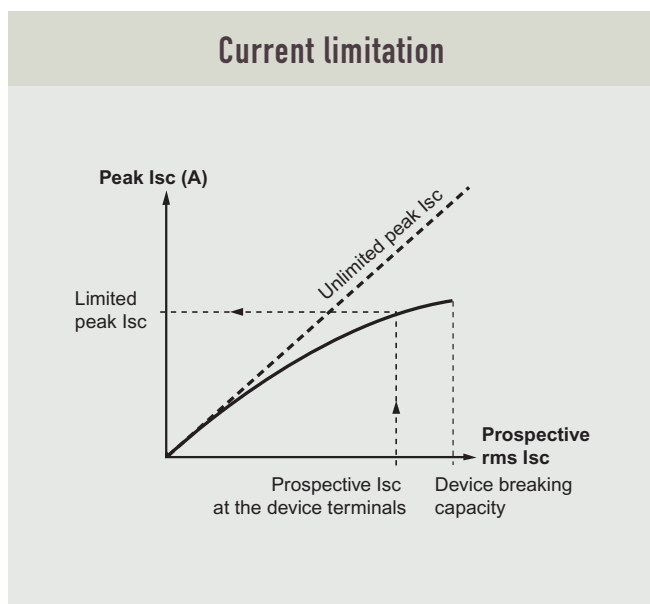

2 THERMAL STRESS LIMITATION CURVES

These give the image of the energy (in A^2s) that the device allows to flow according to the prospective short-circuit current. They can be used to check the thermal stress withstand of cables protected by the device.

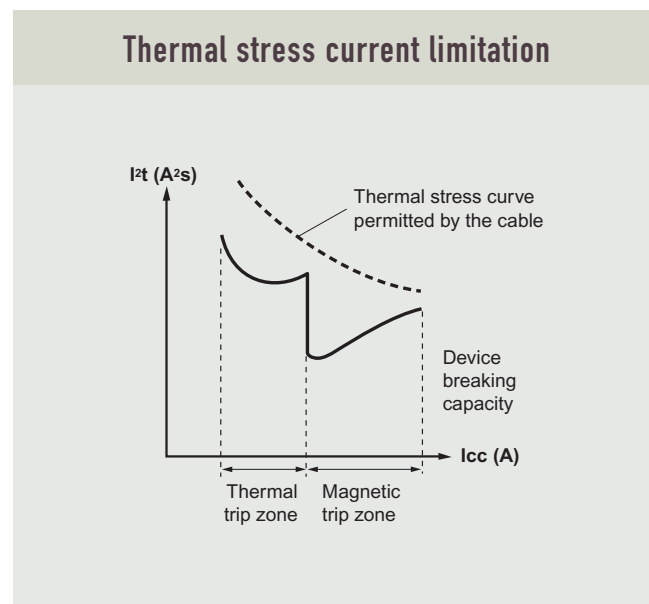

Limitation class for modular circuit breakers

Appendix ZA of standard IEC 60898-1 defines the thermal stress limitation classes for ratings of 40 A or less. The limitation classes are used to classify the thermal stress limiting capacities. Example for a 6 kA type C circuit breaker from 20 to 32 A:

- Class 1: unlimited thermal stress

- Class 2: thermal stress limited to 160 000 A²s maximum
 - Class 3: thermal stress limited to 55 000 A²s maximum
 All Legrand circuit breakers rated 40 A or less are class 3.

DMX³ air circuit breakers

Air circuit breakers get their name from the fact that their breaking chambers are in the open air to allow better energy dissipation. Their electrical and mechanical strength, breaking capacity, maintainability and optional accessories make them ideal for protection and control at the supply end of low voltage installations.

THE DMX³ RANGE

Legrand DMX³ air circuit breakers are ideal for the requirements of low voltage installations up to 4000 A, providing clarity of installation, optimised dimensions, easy mounting and simple connection.

All the devices in the DMX³ range are mounted behind the same faceplate, as they have the same dimensions and an identical front panel.

DMX³ have very high performance, technologically advanced electronic control and protection units. They are available in 3 breaking capacities with just two sizes of device. The designation DMX³-N corresponds to a breaking capacity of 50 kA, DMX³-H to 65 kA, and DMX³-L to 100 kA.

All DMX³ are available in both fixed and draw-out version. In comparison with the fixed version, the draw-out version has additional locking facilities (draw-out position), optimum safety when work is being carried out on them (padlocking and physical separation of the installation) and is easily interchangeable (no disconnection to be carried out).



3-poles
DMX³-H 2500
fixed version

4-poles DMX³-L 4000
draw-out version

Composition of a DMX³

All the circuit breakers are supplied as standard with:

- Manual control
- Terminal blocks for connecting output auxiliaries
- Connection plates
- 4 auxiliary changeover contacts
- Cover for access to lockable settings
- Mechanical indication of activation

And for draw-out versions:

- Mobile contacts for connecting auxiliaries
- IP 40 protection in draw-out position
- Retractable handles
- Padlock of the circuit breaker in inserted-draw-out position

2 sizes only for the entire range

	800 A	1000 A	1250 A	1600 A	2000 A	2500 A	3200 A	4000 A
DMX ³ -N (50 kA)	F1	F1	F1	F1	F1	F1	F2	F2
DMX ³ -H (65 kA)	F1	F1	F1	F1	F1	F1	F2	F2
DMX ³ -L (100 kA)	F2	F2	F2	F2	F2	F2	F2	F2

Draw-out DMX³

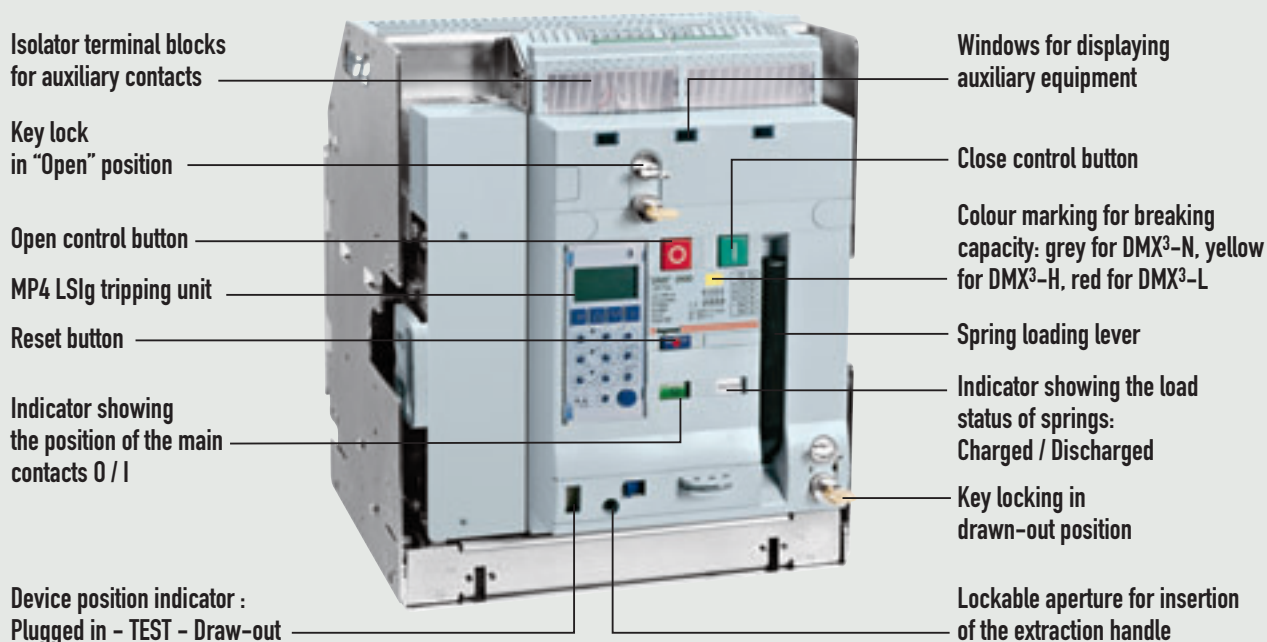

Clear and easy mounting principle

The overall dimensions of the breaker contribute considerably to efficient use of the space inside the electrical panel. The constant depth for all the rated currents facilitates connection of the busbars. In XL³, the DMX³ devices and the associated busbars are arranged using the same principle for all power ratings, ie the possibility of mounting three busbars and two devices per enclosure.

The correct size for the current, and thus the power to be dissipated, is obtained by adapting the depth of the assembly:

- 725 mm min. up to 2500 A
- 975 mm min. up to 4000 A

The installation height of DMX³ units is always 600 mm whatever the type and size of the device. When 2 DMX³ devices are installed in the same enclosure, this leaves at least a useful 600 mm for running the busbars.

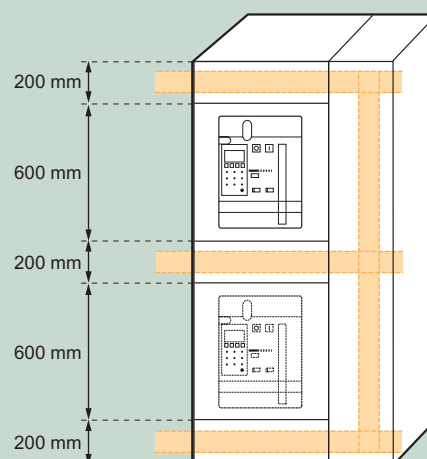

DMX³ air circuit breakers (continued)

TECHNICAL CHARACTERISTICS

Characteristics	DMX ³ 2500			DMX ³ 4000			
	N	H	L	N	H	L	
Frame	F1	F1	F2	F2	F2	F2	
Number of poles	3P - 4P			3P - 4P			
Nominal rating protection unit In (A)	800-2500			3200-4000			
Nominal rating In (A)	800-2500			3200-4000			
Rated insulation voltage Ui (V)	1000			1000			
Rated impulse withstand voltage Uimp (kV)	12			12			
Rated operating voltage (50/60Hz) Ue (V)	690			690			
Ultimate breaking capacity Icu (kA)	230 V AC	50	65	100	50	65	100
	415 V AC	50	65	100	50	65	100
	500 V AC	50	65	100	50	65	100
	600 V AC	50	60	75	50	65	75
	690 V AC	50	55	65	50	65	65
Service breaking capacity Ics (% Icu)	100%			100%			
Closing capacity on short circuits Icm (kA)	230 V AC	105	143	220	105	143	220
	415 V AC	105	143	220	105	143	220
	500 V AC	105	143	220	105	143	220
	600 V AC	105	132	165	105	143	165
	690 V AC	105	121	143	105	143	143
Short-time withstand current Icw (kA) for t = 1 s	230 V AC	50	65	85	50	65	85
	415 V AC	50	65	85	50	65	85
	500 V AC	50	65	85	50	65	85
	600 V AC	50	60	75	50	65	75
	690 V AC	50	55	65	50	65	65
Neutral protection (% In)	OFF-50-100			OFF-50-100			
Category of use	B			B			
Isolation capability	YES			YES			
Opening time	15ms			15ms			
Closing time	30ms			30ms			
Endurance (o.c. cycles) mechanical	10000			10000			
Endurance (o.c. cycles) electrical	5000			5000			
Operating temperature	-5°C to +70°C			-5°C to +70°C			
Storage temperature	-25°C to +85°C			-25°C to +85°C			

Power dissipated per pole (W)

Version	Frame	DMX ³ 2500						DMX ³ 4000	
		800 A	1000 A	1250 A	1600 A	2000 A	2500 A	3200 A	4000 A
Fixed	F1	20	32	50	82	128	200		
	F2	16	25	39	64	100	156	256	400
Draw-out	F1	51	80	125	205	320	500		
	F2	31	48	75	123	192	300	492	768

Temperature derating

Ambient temperature		Up to 40°C		50°C		60°C		65°C		70°C	
Version	Device	I _{max} (A)	I _r / I _n	I _{max} (A)	I _r / I _n	I _{max} (A)	I _r / I _n	I _{max} (A)	I _r / I _n	I _{max} (A)	I _r / I _n
Fixed	DMX ³ 2500	800	1	800	1	800	1	800	1	800	1
		1000	1	1000	1	1000	1	1000	1	1000	1
		1250	1	1250	1	1250	1	1250	1	1250	1
		1600	1	1600	1	1600	1	1600	1	1600	1
		2000	1	2000	1	1960	0,98	1920	0,96	1880	0,94
		2500	1	2450	0,98	2350	0,94	2250	0,9	2150	0,86
	DMX ³ 4000	3200	1	3200	1	3200	1	3136	0,98	3008	0,94
		4000	1	3920	0,98	3680	0,92	3440	0,86	3120	0,78
Draw-out	DMX ³ 2500	800	1	800	1	800	1	800	1	800	1
		1000	1	1000	1	1000	1	1000	1	1000	1
		1250	1	1250	1	1250	1	1250	1	1250	1
		1600	1	1600	1	1600	1	1600	1	1600	1
		2000	1	2000	1	1960	0,98	1920	0,96	1875	0,94
		2500	1	2400	0,96	2250	0,9	2100	0,84	1950	0,78
	DMX ³ 4000	3200	1	3200	1	3200	1	3072	0,96	2880	0,9
		4000	1	3760	0,94	3440	0,86	3200	0,8	2960	0,74

Altitude derating

Altitude (m)	< 2000	3000	4000	5000
U _e (V)	690	600	500	440
U _i (V)	1000	900	750	600
I _n (A) (T = 40°C)	I _n	0.98 x I _n	0.94 x I _n	0.9 x I _n

Dimensions and weight

		Fixed		Draw-out		
		3P	4P	3P	4P	
Frame 1	width (mm)	273	358	327	412	
	depth (mm)	354	354	433	433	
	height (mm)	419	419	473	473	
	volume (dm ³)	41	53	67	84	
	weight (kg)	DMX ³	41	48	77	94
		DMX ³ -I	39	45	75	91
Frame 2	width (mm)	408	538	425	555	
	depth (mm)	354	354	433	433	
	height (mm)	419	419	473	473	
	volume (dm ³)	61	80	87	114	
	weight (kg)	DMX ³	59	76	108	137
		DMX ³ -I	57	73	106	134

DMX³ air circuit breakers (continued)

ELECTRONIC PROTECTION UNITS

DMX³ air circuit breakers have modern protection units that enable very precise setting of the protection conditions while maintaining total discrimination with the upstream devices.

The MP4 standard electronic protection unit is available in three versions: LI, LSI and LSIg according to the settings it provides.

The MP6 protection unit has additional functions and its touch screen makes it very easy to use. It is available in 2 versions: LSI and LSIg.

- L: long delay protection against overloads (times t_r and currents I_r)
- S: short delay protection against short circuits (times t_m and currents I_m)
- I: instantaneous protection against very high intensity short circuits (I_i)
- g: protection against earth faults (times t_g and currents I_g)

Residual current protection (with external core) is optionally available on all models.

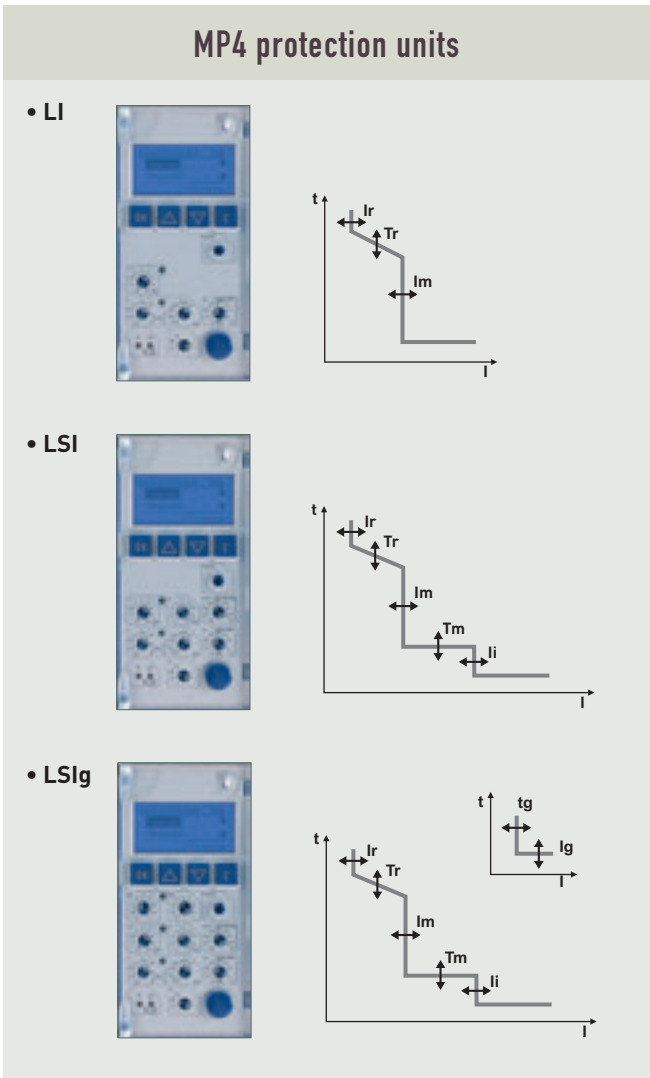

! All DMX³ breakers are factory equipped with one of the protection units on catalogue: MP4 protection unit LI, LSI or LSIg or MP6 LSI or LSIg according to your requirements. You just need to select and indicate the two catalogue numbers when placing the order (1 for the breaker and 1 for the tripping unit)

MP6 protection units

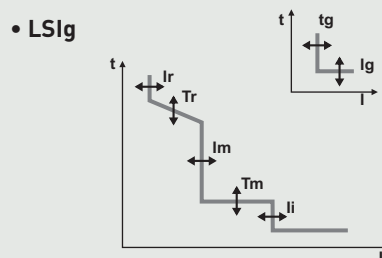
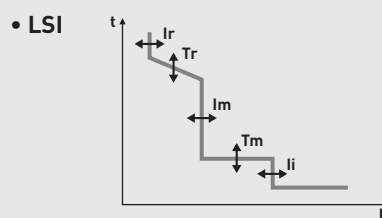

The touch screen and icon-based navigation on the MP6 unit make it very intuitive to use. The colour display provides a clear presentation of the parameters of the installation: voltages, currents, powers, frequency, harmonics.

The MP6 unit can be used even when there is no power, without having to use an external power supply, as it has an integrated battery.

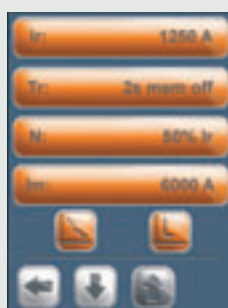

Integrated measurement unit

The MP6 protection unit has an advanced measurement unit which, in addition to monitoring currents, can also be used to display Ph/N and Ph/Ph voltages, active and reactive powers (total and per phase), frequency, power factor (total and per phase), active and reactive energy and also harmonic distortion.

Alarms can be programmed on a number of these parameters: max. voltage, min. voltage, voltage imbalance, max. and min. frequencies, etc.

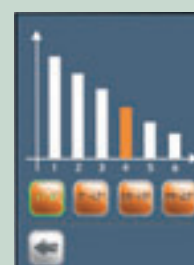

DMX³ air circuit breakers (continued)

Functions of electronic protection units						
Electronic protection unit		MP4			MP6	
		LI	LSI	LSIg	LSI	LSIg
Long delay protection against overloads	I _r adjustable: from 0.4 to 1.0 x I _n in 0.02 intervals	•	•	•	•	•
	t _r adjustable: 5-10-20-30 s (MEM ON) 30-20-10-5 s (MEM OFF)	•	•	•	•	•
Short delay protection against short circuits	I _m adjustable: from 1.5 to 10 x I _r in 0.5 intervals		•	•	•	•
	t _m adjustable: 0-0.1-0.2-0.3 s (t constant) 0.3-0.2-0.1-0.01s (I ² t constant)		•	•	•	•
Instantaneous protection	I _i adjustable: 2-3-4-6-8-10-12-15-I _{cw} x I _n	•	•	•	•	•
Protection against earth faults	I _g adjustable: OFF-0.2-0.3-0.4-0.5-0.6-0.7-0.8-1 x I _n			•		•
	t _g adjustable: 0.1-0.2-0.5-1 s (t constant) 1-0.5-0.2-0.1 s (I ² t constant)			•		•
Residual current protection (with external core)	I _d adjustable: OFF-1-1-3-3-10-10-30-30 A	optional	optional	optional	optional	optional
	t _d adjustable: 0.1-0.1-0.3-0.3-1-1-3-3 s	optional	optional	optional	optional	optional
Neutral protection	4P: OFF-50-100-200%I _r (no 200% up to 1250 A and 100% above)	•	•	•	•	•
	3P: OFF-50-100-200%I _r (4000 A max.)	•	•	•	•	•
Protection against overloads	T _{max} fixed: 95°C	•	•	•	•	•
Measurements and display (instantaneous values, maximum and mean, adjustable time)	Current	•	•	•	•	•
	Ph/N and Ph/Ph voltage				•	•
	Power (P,Q,A): total and per phase				•	•
	Frequency				•	•
	Power factor: total and per phase				•	•
	Energy (active and reactive)				•	•
	Calculation of harmonic distortion				•	•
Display	Monochrome LCD display	•	•	•		
	Colour touch screen				•	•
	Current	•	•	•	•	•
	Position: open/closed/fault	•	•	•	•	•
	Date, time and reason for last activation	•	•	•	•	•
	Required protection	•	•	•	•	•
Memorisation	Date and time	•	•	•	•	•
	Activation counter	•	•	•	•	•
	Current not broken	•	•	•	•	•
	Date, time and reason for last 20 activations	•	•	•	•	•
	Voltage dip				•	•

Functions of electronic protection units (continued)

Electronic protection unit		MP4			MP6	
		LI	LSI	LSIg	LSI	LSIg
External links	USB port for diagnostic software	•	•	•	•	•
	Terminal block for auxiliaries	•	•	•	•	•
	ModBus on RS485	optional	optional	optional	optional	optional
Signalling and alarms	Overheating >75°C	•	•	•	•	•
	Logical discrimination	•	•	•	•	•
	Management of non-priority loads				•	•
	Power return: 0.1 to 20 s - 5 to 100% I _r				•	•
	Current imbalance: 1 to 3600 s - 100 to 600 V				•	•
	Max. Ph/N voltage: 0.1 to 20 s - 60 to 400 V				•	•
	Min. Ph/N voltage: 0.1 to 20 s - 10 to 400 V				•	•
	Ph/N voltage imbalance: 0.1 to 20s - instantaneous				•	•
	Inversion of phase rotation				•	•
	Max. frequency: 45 to 500 Hz - 0.1 to 20 s				•	•
	Min. frequency: 45 to 400 Hz - 0.1 to 20 s				•	•



Memory settings

If a device is changed, the electronic tripping unit retains the settings and all the data recorded during operation of the breaker which was previously installed (faults, operations, currents, etc).

This function makes maintenance safe and reduces downtime to a minimum. The settings are thus no longer associated with the device, but with the circuit which is being protected.

On standard, all protection units are equipped with batteries so you can monitor and adjust the parameters even when the breaker is not connected. For example, it's possible to set the protection unit before install the breaker or see the info inside during a trip.



Maintenance of Air Circuit Breakers (ACB)

The requirements for functional security of the electrical systems are strategic in many domains of activity (norm IEC 61508).

By conception, in the planning of preventive maintenance, the ACBs are designed to permit a series of interventions at different levels: cleaning of breaking chamber, verification and possible change of the worn out elements, etc.

The specific Legrand documents give the detailed procedures of the operations to do.

DMX³ air circuit breakers (continued)

COMMUNICATION AND SUPERVISION

The MP4 and MP6 electronic protection units can communicate with an RS-485 communication port. This port is used for remote monitoring and management of the devices in the installation, using the MODBUS protocol. It is therefore possible to control circuit breaker opening and closing, display the electrical parameters and detect all the alarms generated by the devices, from a PC.

With the new DMX³, the installation and protection devices can be managed in a simple, functional way, determining the state of the circuit breaker at any time and solving most problems via the network. Using the circuit breaker's supervision system, maintenance operations can be planned and the efficiency of the installation optimised.

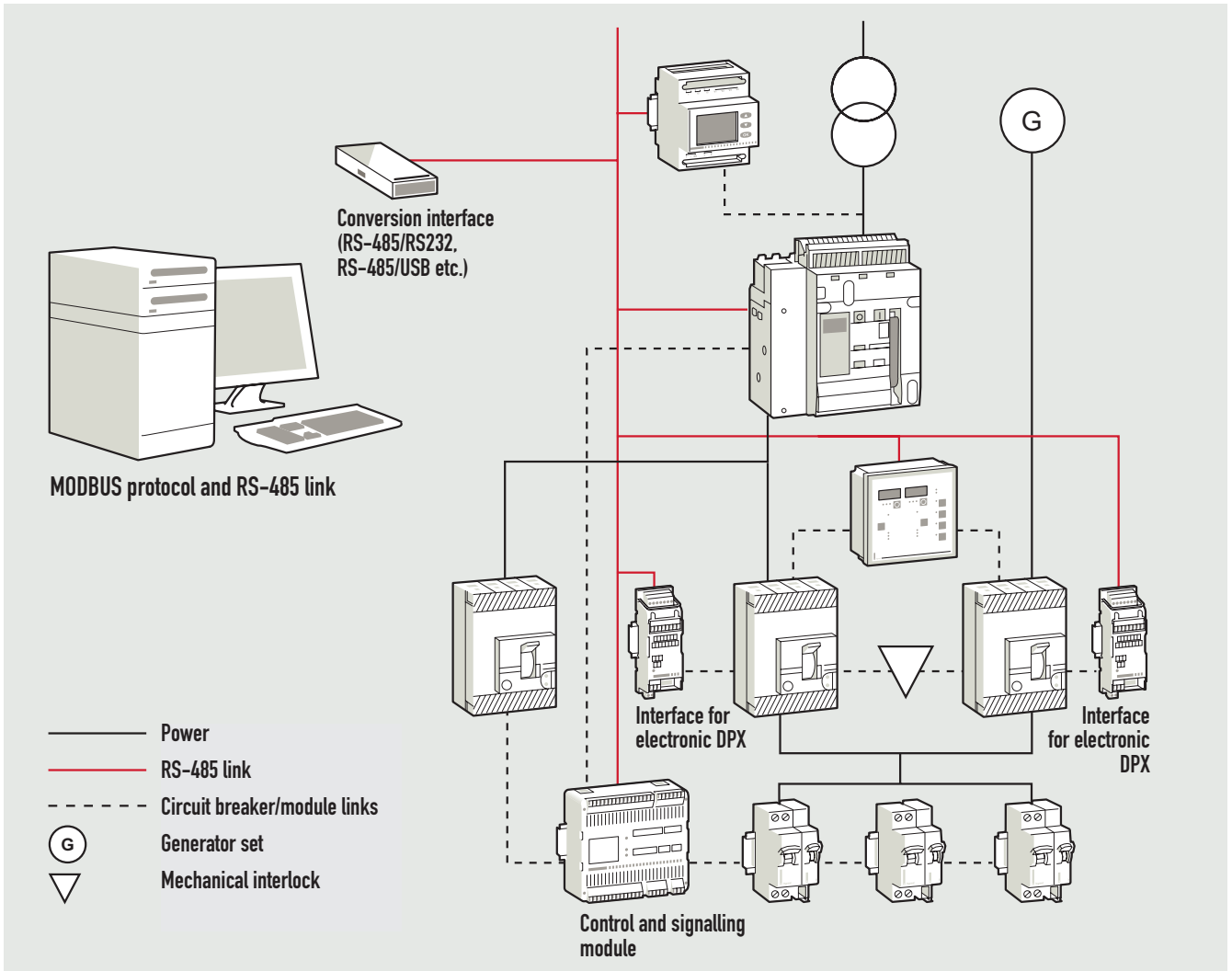

ACCESSORIES

1 SHUNT TRIP

Shunt trips are devices used for the remote instantaneous opening of the air circuit breaker. They are generally controlled through an N/O type contact. The current range of shunt trips proposes five supply voltages from 24 V to 415 V). The shunt trips are already equipped with a special fast connector, to be directly inserted into auxiliary contact block. An auxiliary contact is connected in series with the coil, cutting off its power supply when the main poles are open

- Nominal voltage Un: - 24, 48, 110, 230 V AC/DC
- 415 V AC
- Tolerance on nominal voltage: 70 to 110% Un
- Maximum power consumption (for 180 ms):
500 VA AC/500 W DC
- Continuous power: 5 VA AC/5 W DC
- Maximum opening time: 30 ms
- Insulation voltage: 2500 V 50 Hz for 1 min
- Endurance on pulse: surge proof 4 kV 1.2/50 ms

2 UNDERVOLTAGE RELEASE

Undervoltage releases are devices which are generally controlled by an N/C type contact. They trigger instantaneous opening of the circuit breaker if their supply voltage drops below a certain threshold and in particular if the control contact opens. These releases are equipped with a device for limiting their consumption after the circuit has been closed.

- Nominal voltage Un: - 24, 48, 110, 230 V AC/DC
- 415 V AC
- Tolerance on nominal voltage: 70 to 110% Un
- Maximum power consumption (for 180 ms):
500 VA AC/500 W DC
- Continuous power: 5 VA AC/5 W DC
- Opening time: 60 ms
- Insulation voltage: 2500 V 50 Hz for 1 min
- Endurance on pulse: surge proof 4 kV 1.2/50 ms

3 CLOSING COILS

These coils are used for remotely controlling the closing of the power contacts of the circuit breaker.



Electrical auxiliaries are connected on the front panel in no time, thanks to the fast connector supplied on all accessories.

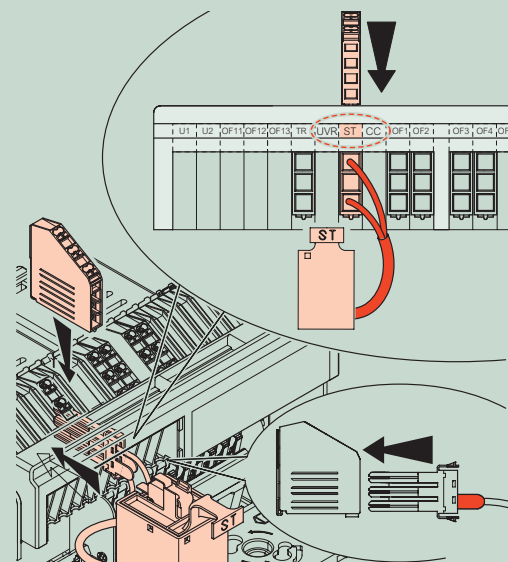

The output terminal block has automatic terminals for connection without screws

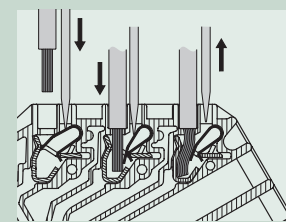

The springs of the circuit breaker are to be loaded prior to the action of the closing coils. They are controlled by an N/O type contact.

- Nominal voltage Un: - 24, 48, 110, 230 V AC/DC
- 415 V AC
- Tolerance on nominal voltage: 70 to 110% Un
- Maximum power consumption (for 180 ms):
500 VA AC/500 W DC
- Continuous power: 5 VA AC/5 W DC
- Maximum closing time: 50 ms
- Insulation voltage: 2500 V 50 Hz for 1 min
- Endurance on pulse: surge proof 4 kV 1.2/50 ms

DMX³ air circuit breakers (continued)

4 MOTOR OPERATORS

Motor operators, are used for remotely reloading the springs of the circuit breaker mechanism immediately after the device closes. The device can thus be re-closed almost immediately after an opening operation. To motorise a DMX³ it is necessary to add a release coil (undervoltage release or shunt trip) and a closing coil. If the supply voltage of the controls fails, it is still possible to reload the springs manually. Motor-driven controls have “limit switch” contacts which cut off the power supply of their motor after the springs have been reloaded. Motor operators are easy to mount, with only three screws.

- Nominal voltage Un: 24 V AC/DC, 48 V V AC/DC, 110 V AC/DC, 230 V AC/DC , 415 V AC
- Tolerance on nominal voltage: 85 to 110% Un
- Spring reloading time: 5 s
- Maximum power consumption: 140 VA AC/140 W DC
- Starting current: 2 up to 3 In 0.1 s
- Maximum cycle: 2/min

5 SIGNALLING CONTACTS

All DMX³ air circuit breakers are equipped as standard with 4 auxiliary contacts that can be used independently like NO or NC contact. It's also possible to more auxiliary contacts up to reach the number of 10.

Mounting auxiliaries

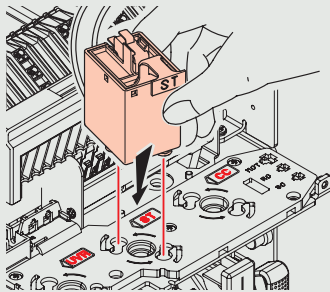

Auxiliaries are very easy to mount in the top part of the DMX³, behind the front panel. The positions are marked to prevent mounting errors. It is possible to install up to 2 current shunt trips or 2 undervoltage releases and a closing coil. Auxiliaries are identified on the front panel. The front panel of the DMX³ has windows so that users can check what auxiliaries are installed and their characteristics.

Max number of auxiliaries

shunt trip	undervoltage release	closing coil
1	1	1
2	0	1
0	2	1

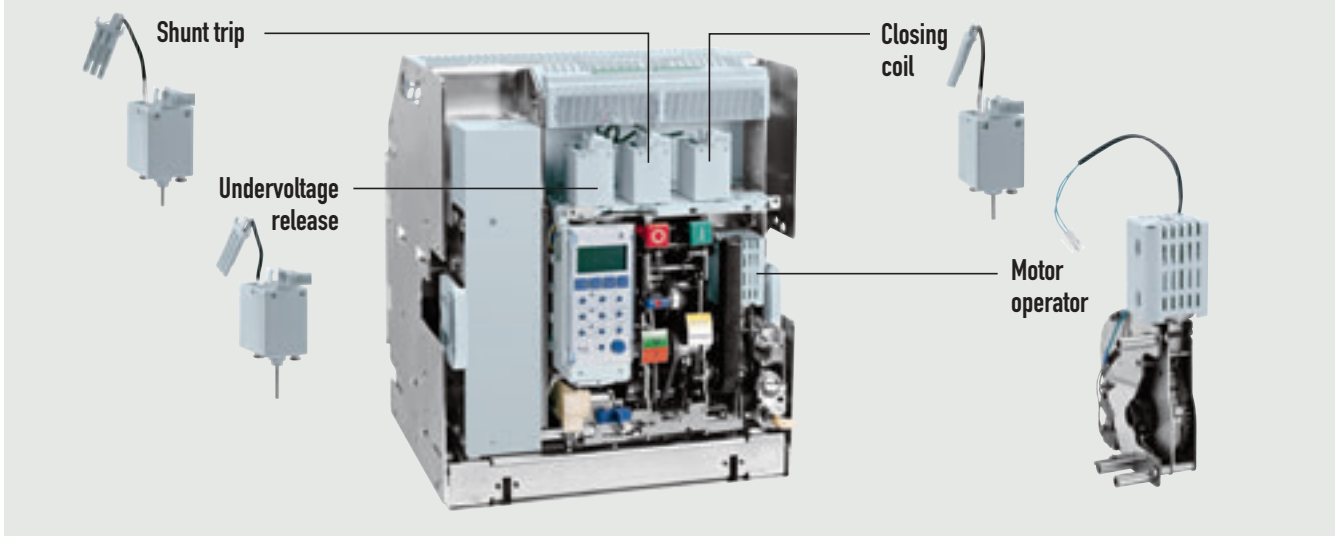

Connection diagram

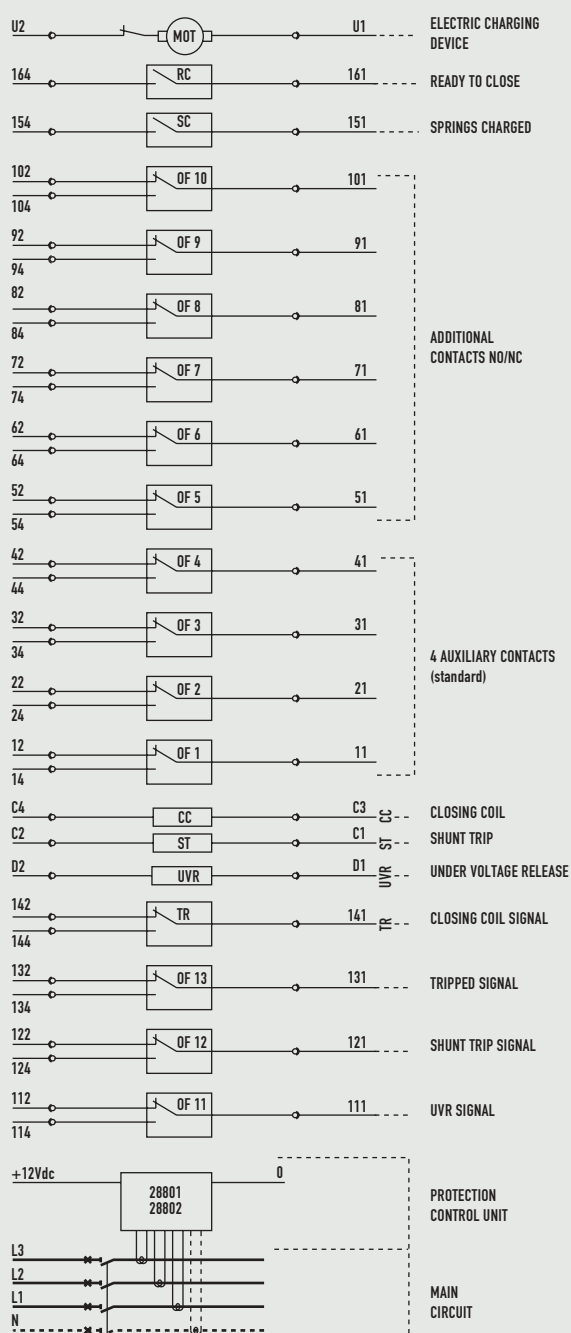

6 SAFETY AND PADLOCKING ACCESSORIES

DMX³ draw-out circuit breakers are provided as standard with safety padlocking shutters preventing access to live terminals. They have a number of other safety devices, such as:

Key-operated locks:

- Main contacts open
- Circuit breaker in draw-out position

Padlocks for:

- Main contacts open
- Contact shutters closed (for draw-out position)

Door locking:

in order to prevent the opening of the electrical switchboard door when the contacts of the ACB are closed.



^ Key locking in open position

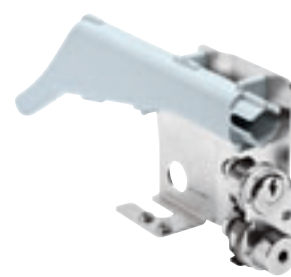

^ Key locking accessory for draw-out devices

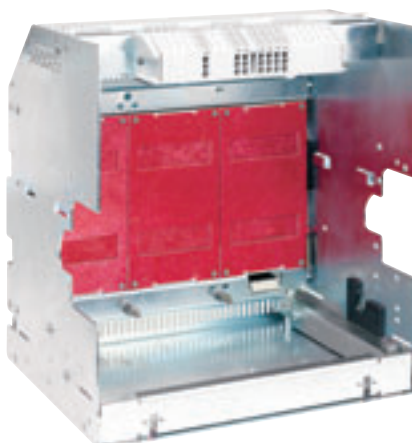

< Safety shutters provide protection against the risk of contact with live parts, as standard on every draw-out version DMX³

DMX³ air circuit breakers (continued)

CONNECTING DMX³

Correct sizing and connection are crucial for the reliability of installations and in particular for high power and very high power equipment. DMX³, both fixed and draw-out version, have generously sized connection plates and accessories enabling all connection configurations (flat, vertical, horizontal).

Fixed version



Fixed version breakers are supplied with rear terminals for horizontal connection



Rear terminals on accessories allow flat or vertical connection

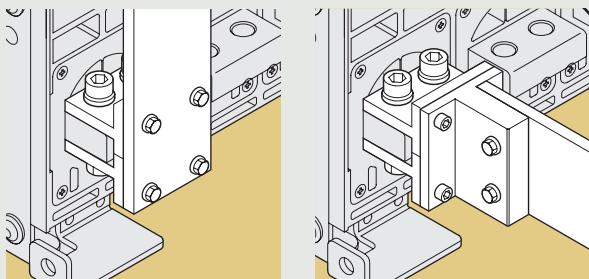

Draw-out version



Draw-out version breakers are supplied with rear terminals for flat connection



Reversible connectors allow vertical or horizontal connection

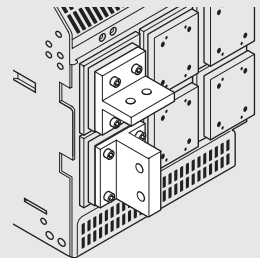

Spreaders

For size 1, fixed version DMX³, spreaders make it possible to use wider plates, in particular for connecting aluminium bars.

For flat connection



For vertical connection



For horizontal connection





Derating (A) according to the type of connection and minimum recommended cross-sections of bars

Installing circuit breakers in enclosures sometimes leads to the need to reduce the rated current. This derating is due to a risk of overheating according to the connection configuration on the busbar. The table opposite can be used to determine this derating according to the ambient temperature in the enclosure and the type of connection used. This table must however be considered as an example only. It refers to installation in an XL³ 4000 enclosure with the following dimensions:

- 2200 x 800 x 800 mm for a size 1 DMX³
- 2200 x 1400 x 800 mm for a size 2 DMX³

The values in the table are given for a plug-in circuit breaker in an IP 40 assembly with no internal separation and for a maximum terminal temperature of 120°C.

	In (A)	Ambient temperature			Copper bars (mm ²)
		35°C	45°C	55°C	
Vertical connection	800	800	800	800	1 x 60 x 10
	1000	1000	1000	1000	1 x 80 x 10
	1250	1250	1250	1250	1 x 80 x 10
	1600	1600	1600	1600	2 x 60 x 10
	2000	2000	2000	1800	2 x 80 x 10
	2500	2500	2500	2500	3 x 80 x 10
	3200	3200	3100	2800	3 x 100 x 10
	4000	4000	3980	3500	4 x 100 x 10
Horizontal or flat connection	800	800	800	800	1 x 60 x 10
	1000	1000	1000	1000	1 x 80 x 10
	1250	1250	1250	1200	2 x 60 x 10
	1600	1550	1450	1350	2 x 80 x 10
	2000	2000	2000	1750	3 x 80 x 10
	2500	2500	2450	2400	3 x 80 x 10
	3200	3000	2880	2650	3 x 100 x 10
	4000	3600	3510	3150	6 x 60 x 10

Connection options

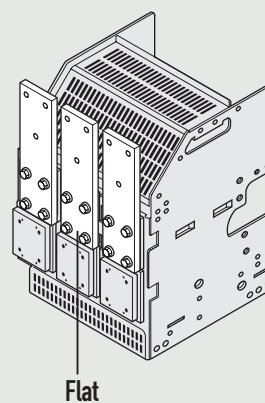
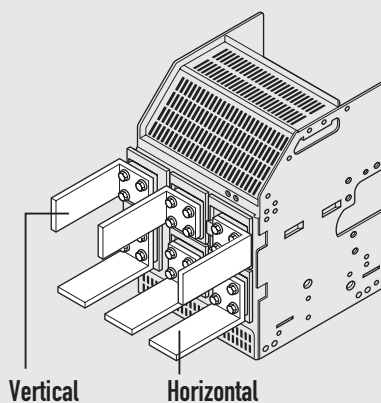
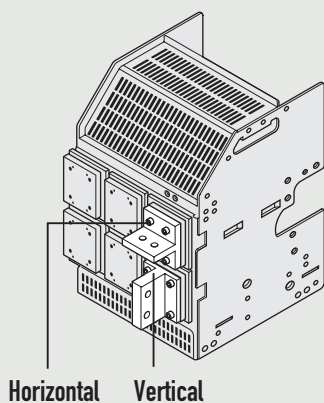

→ Dimensions of connection plates p. 39-41

DMX³ air circuit breakers (continued)

SUPPLY INVERTERS

Supply inverter performs the following functions:

- Switching between a main source and a secondary source in order to supply circuits requiring continuous service (for safety reasons) or for energy saving purposes (when the secondary source is different from the network).
- Management of the operation of the secondary source supplying the safety circuits.

DMX³ and DMX³-I devices can be fitted with an interlocking mechanism which ensures “mechanical safety” in the event of supply inversion. Interlocking is achieved using interlocking units mounted on the side of the devices and a cable system. This system allows devices of different sizes and types to be interlocked. The cable system provides the flexibility to install DMX³ devices in a vertical configuration in the same enclosure or in a horizontal configuration in different columns.

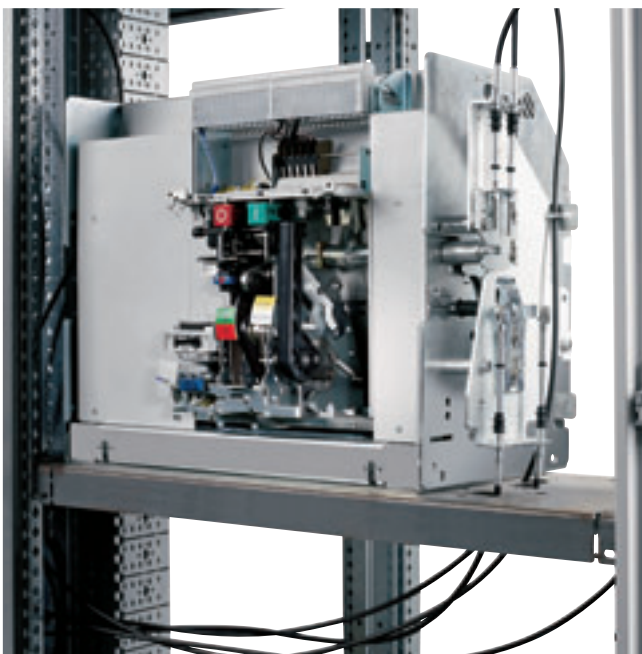

^ The interlocking mechanism with cables is easy to add to all DMX³ versions and is not dependent on their position in the assembly

DMX³ supply inverters used with XL³ 4000 enclosures enable very intuitive configuration of assemblies and busbars, as shown in the examples below.

Stand-by power supply (without load shedding)

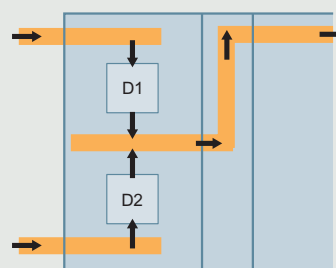
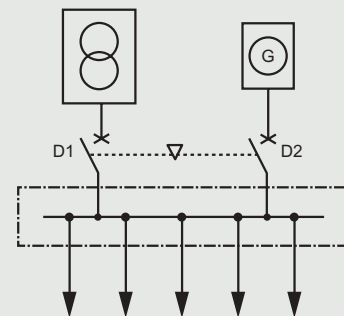

The two DMX³ devices D1 and D2 are connected to a central common busbar. Since they are not simultaneously on-load, they can be in the same enclosure.



It is possible to install two devices in the same enclosure if they are not both on-load simultaneously (supply inversion) or if the sum of their respective currents does not exceed the values recommended for correct thermal dissipation. Otherwise, a single device must be installed in each enclosure.

Stand-by power supply (with load shedding)

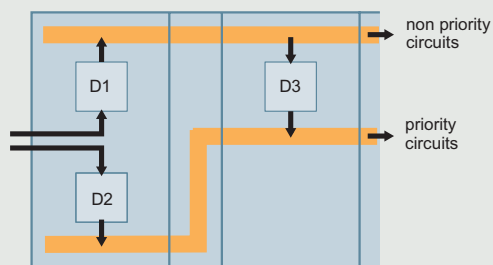
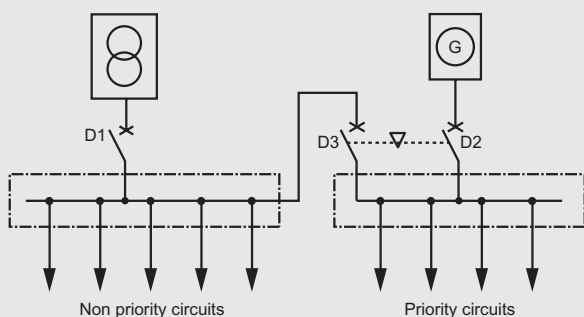

The two DMX³ devices D1 and D2 are not on-load simultaneously and can therefore be installed in the same enclosure. D3 can be on-load at the same time as D1, and must be installed in another enclosure.

Dual power supply (reduced power with priority loads)

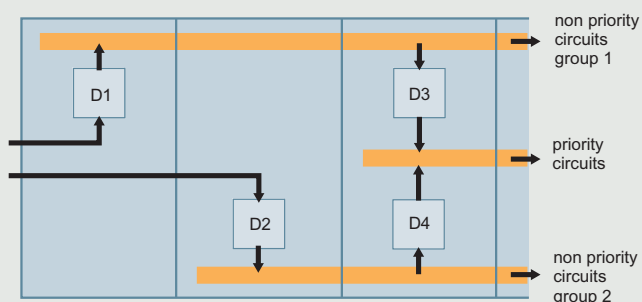
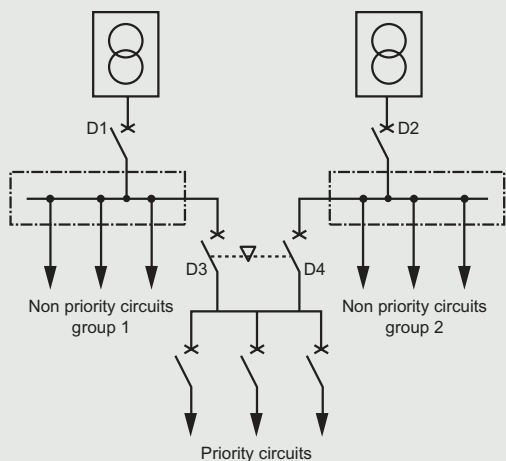

The two DMX³ devices D1 and D2 are on-load simultaneously. They can only be installed in the same enclosure if the sum of their currents does not exceed the permissible value for the recommended size. D3 and D4 are not simultaneously on-load, they can be in the same enclosure.



The ambient temperature in the enclosure must be limited as far as possible to a value which does not exceed 40°C. Above this limit it becomes necessary to modify the permissible current value in the protection devices and the bars (see p. 15).

DMX³ air circuit breakers (continued)

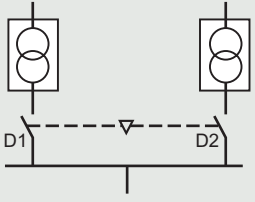
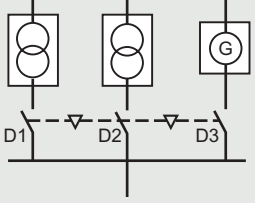
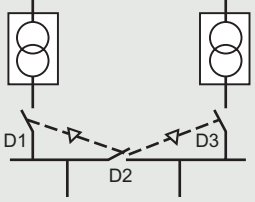
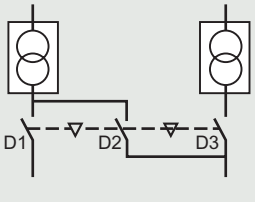
Examples of mechanical interlocking																										
<p>The following example involves two circuit breakers. D1 is used for the main power supply of the installation (normal operation), D2 for emergency power supply via a power generator (in case of mains fault). For this configuration the two breakers can be simultaneously open, but can not be closed at the same time.</p>		<table border="1"> <thead> <tr> <th>D1</th> <th>D2</th> </tr> </thead> <tbody> <tr> <td>0</td> <td>0</td> </tr> <tr> <td>1</td> <td>0</td> </tr> <tr> <td>0</td> <td>1</td> </tr> </tbody> </table>	D1	D2	0	0	1	0	0	1																
D1	D2																									
0	0																									
1	0																									
0	1																									
<p>The following example involves three circuit breakers connected to one common busbar. D1 and D2 breakers are supplying the energy from two different power transformers and D3 from a power generator (in case of emergency). For this configuration all three breakers can be simultaneously open. At any time, only one single circuit breaker can be on-load. The following table shows all possible combinations of mechanical interlocking of the 3 breakers.</p>		<table border="1"> <thead> <tr> <th>D1</th> <th>D2</th> <th>D3</th> </tr> </thead> <tbody> <tr> <td>0</td> <td>0</td> <td>0</td> </tr> <tr> <td>1</td> <td>0</td> <td>0</td> </tr> <tr> <td>0</td> <td>1</td> <td>0</td> </tr> <tr> <td>0</td> <td>0</td> <td>1</td> </tr> </tbody> </table>	D1	D2	D3	0	0	0	1	0	0	0	1	0	0	0	1									
D1	D2	D3																								
0	0	0																								
1	0	0																								
0	1	0																								
0	0	1																								
<p>The following example involves three circuit breakers, with double mechanical interlock for D2 circuit breaker. D1 and D3 breakers are supplying the electricity form 2 power transformers. There are 6 possible interlocking combinations.</p>		<table border="1"> <thead> <tr> <th>D1</th> <th>D2</th> <th>D3</th> </tr> </thead> <tbody> <tr> <td>0</td> <td>0</td> <td>0</td> </tr> <tr> <td>1</td> <td>0</td> <td>0</td> </tr> <tr> <td>0</td> <td>0</td> <td>1</td> </tr> <tr> <td>0</td> <td>1</td> <td>0</td> </tr> <tr> <td>1</td> <td>1</td> <td>0</td> </tr> <tr> <td>0</td> <td>1</td> <td>1</td> </tr> <tr> <td>1</td> <td>0</td> <td>1</td> </tr> </tbody> </table>	D1	D2	D3	0	0	0	1	0	0	0	0	1	0	1	0	1	1	0	0	1	1	1	0	1
D1	D2	D3																								
0	0	0																								
1	0	0																								
0	0	1																								
0	1	0																								
1	1	0																								
0	1	1																								
1	0	1																								
<p>The following example involves three circuit breakers, with double mechanical interlocking for D2 circuit breaker. It is a possible version of the previous layout, and has four combinations. D1 and D3 breakers supply energy for independent circuits. D2 breaker is used in case of emergency for priority circuits.</p>		<table border="1"> <thead> <tr> <th>D1</th> <th>D2</th> <th>D3</th> </tr> </thead> <tbody> <tr> <td>0</td> <td>0</td> <td>0</td> </tr> <tr> <td>1</td> <td>0</td> <td>0</td> </tr> <tr> <td>0</td> <td>0</td> <td>1</td> </tr> <tr> <td>1</td> <td>0</td> <td>1</td> </tr> <tr> <td>0</td> <td>1</td> <td>0</td> </tr> </tbody> </table>	D1	D2	D3	0	0	0	1	0	0	0	0	1	1	0	1	0	1	0						
D1	D2	D3																								
0	0	0																								
1	0	0																								
0	0	1																								
1	0	1																								
0	1	0																								



Automation control unit



The mechanical interlocking system can be supplemented by motorised operators and an electronic control unit, making the inverter fully automatic.

Choice of interlocking cable

Type of cable	Length (m)
1	2.6
2	3
3	3.6
4	4
5	4.6
6	5.6

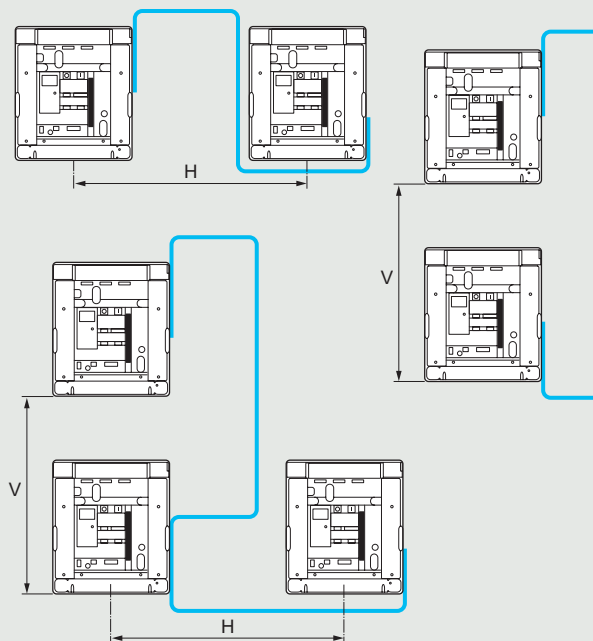

Distances between devices	H (mm)			
	0	725 to 1000	1000 to 2000	
V (mm)	0	Type 1	Type 3	
	800 to 1000	Type 1	Type 2	Type 5
	1000 to 2000	Type 3	Type 4	Type 6



^ It is very easy to create the required configuration thanks to the different available sizes of XL³ 4000 enclosures and interlocking cables

DMX³ air circuit breakers (continued)

PERFORMANCE DATA AND LIMITATION CURVES

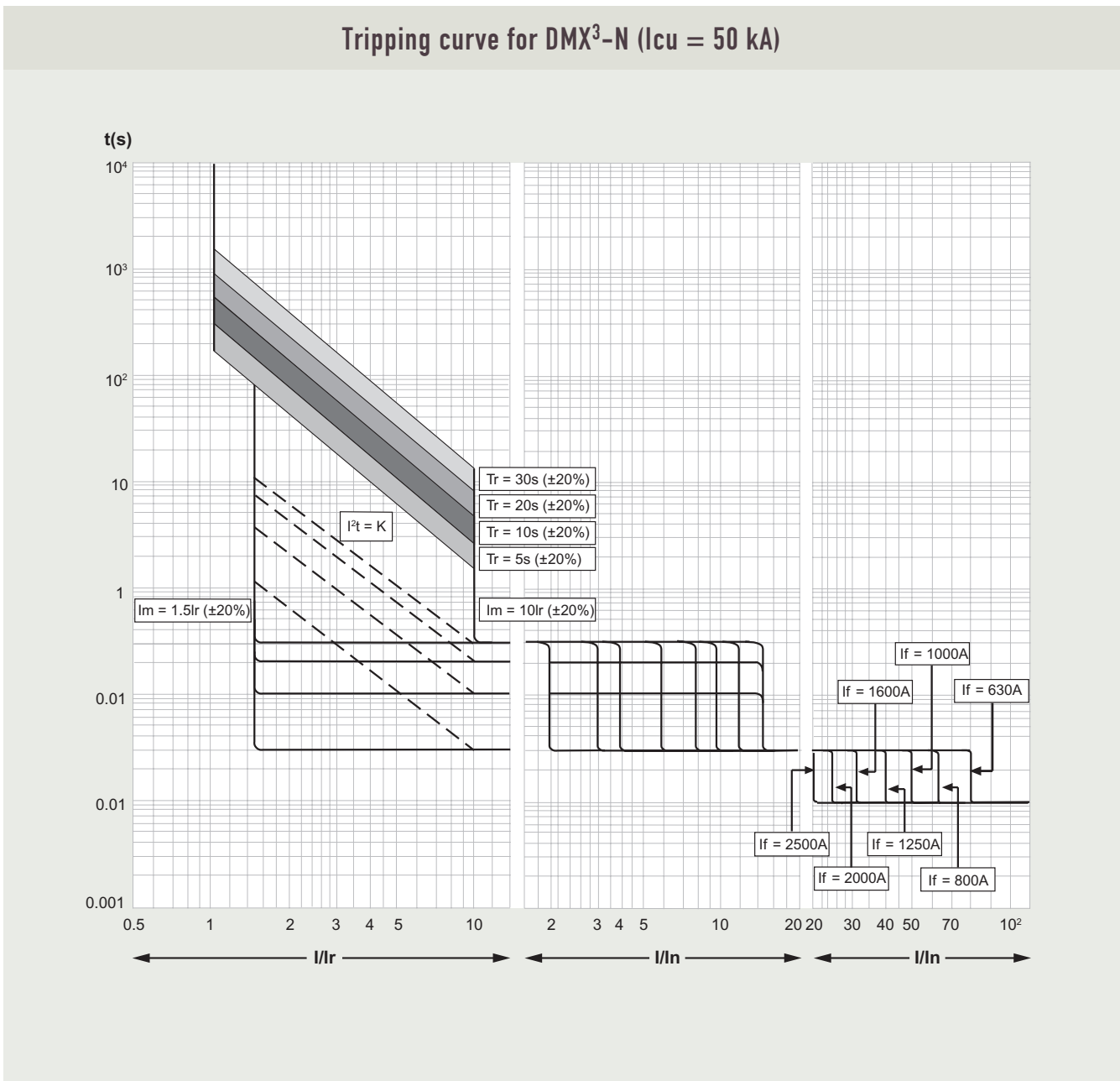

Tripping curve for DMX³-H (I_{cu} = 65 kA)

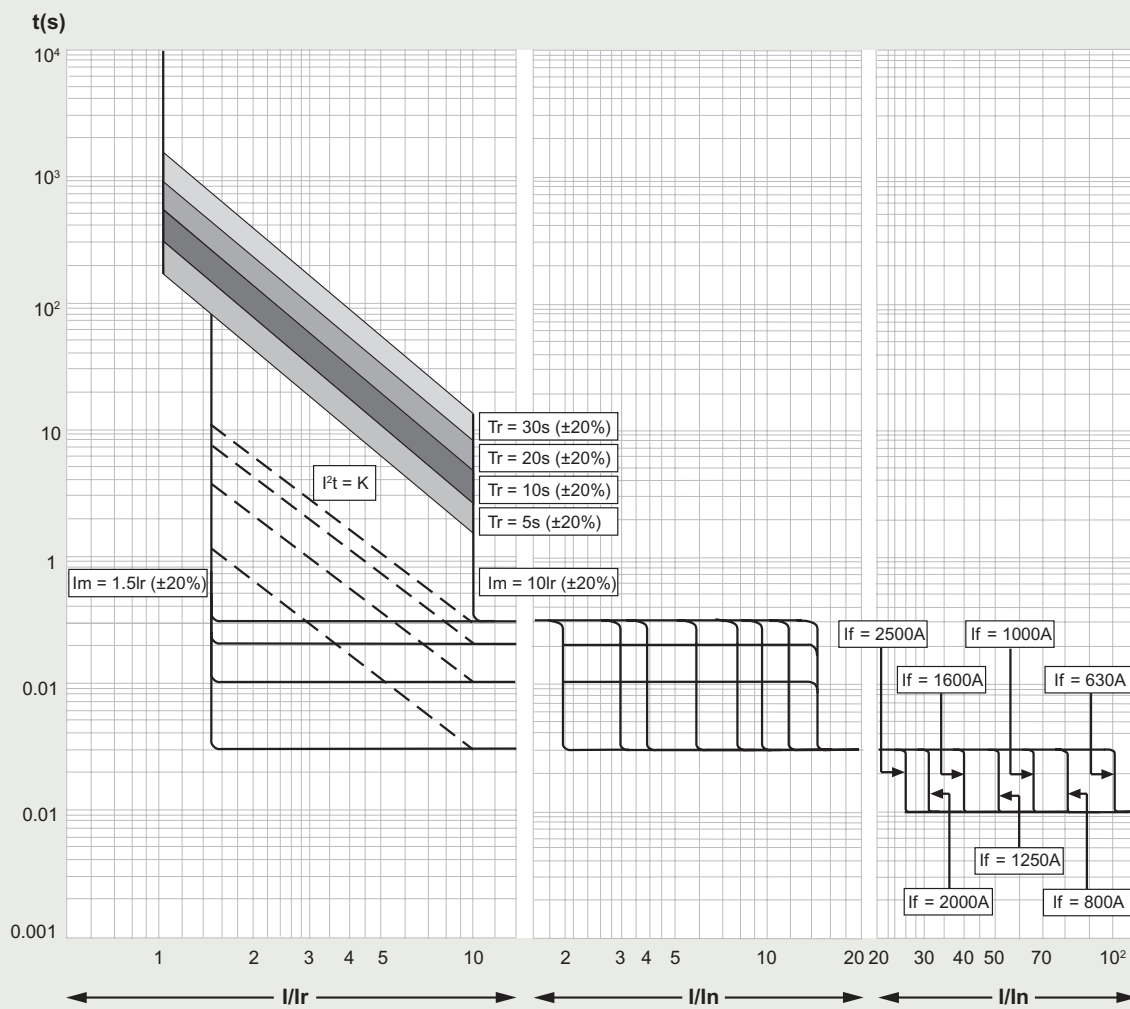

DMX³ air circuit breakers (continued)

Tripping curve for DMX³-L (I_{cu} = 100 kA)

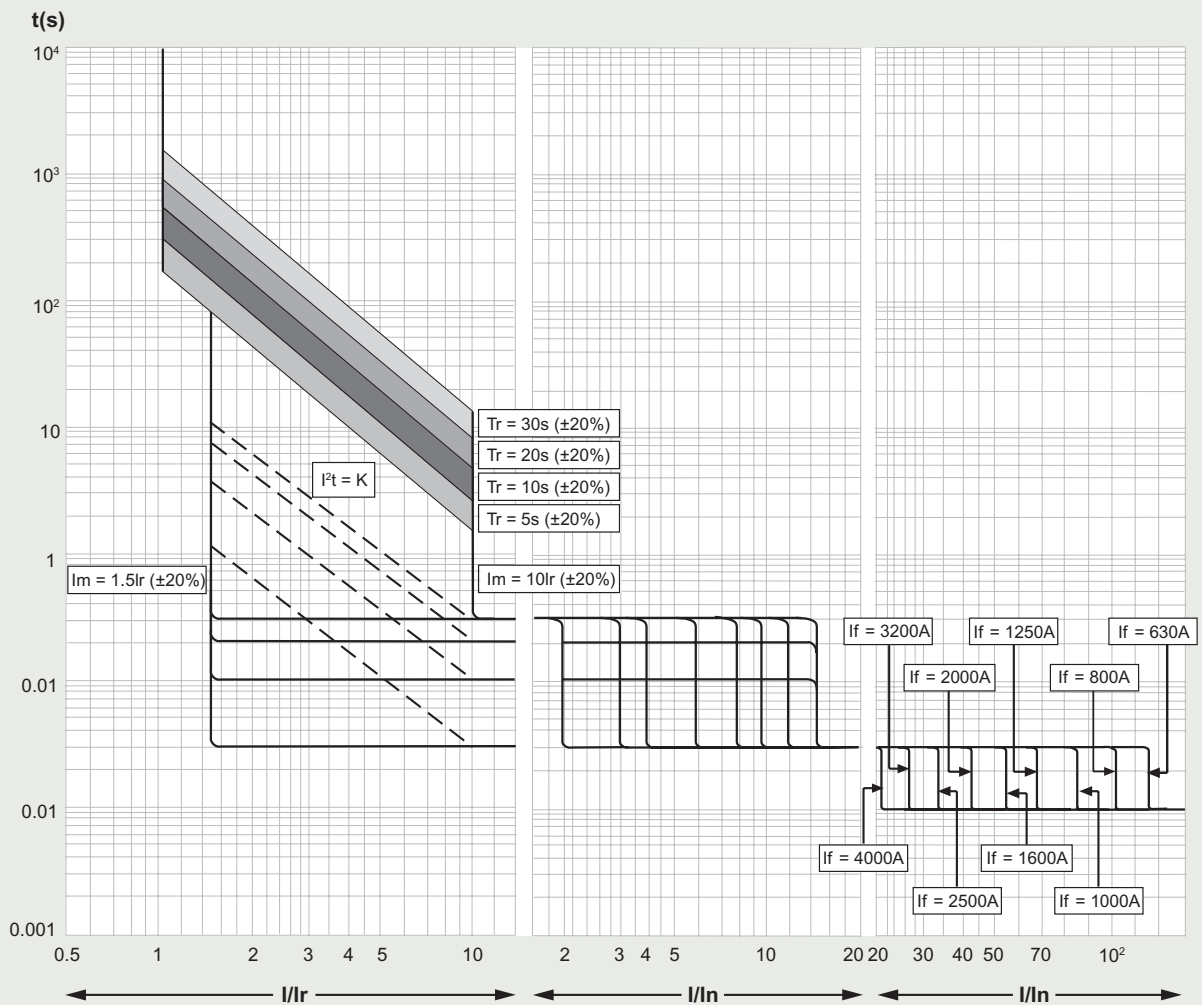

Tripping curve on earth fault

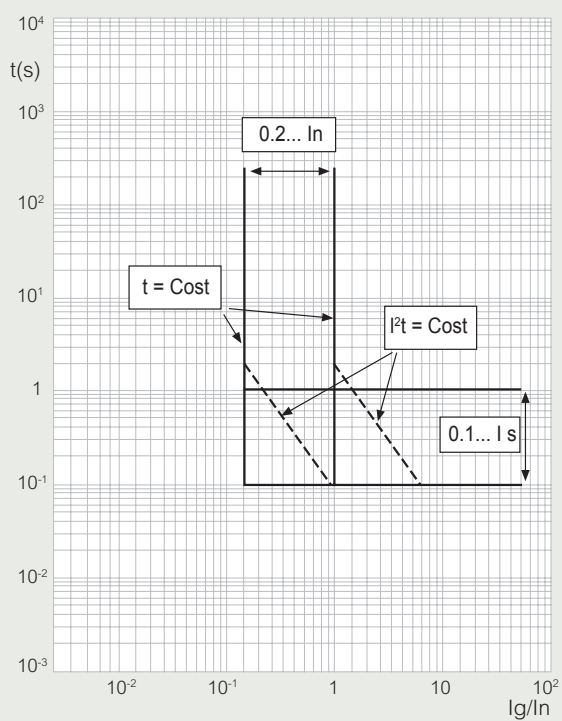

Thermal stress limitation

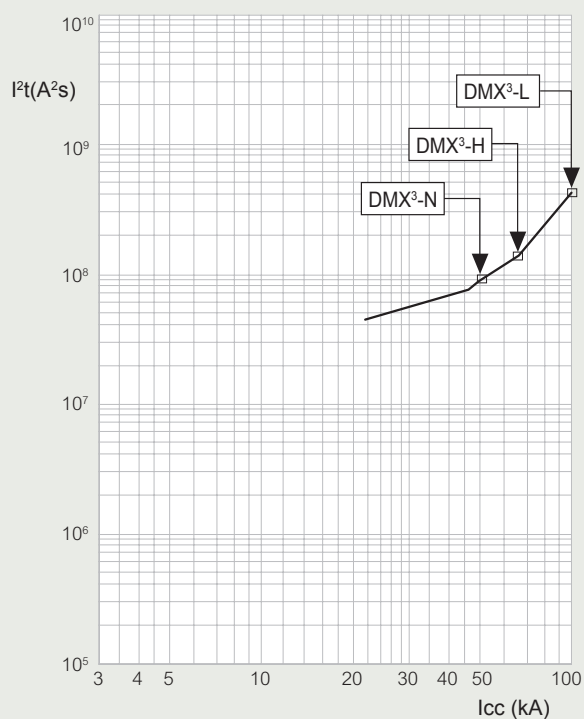

DMX³ air circuit breakers (continued)

DIMENSIONS

1 FIXED VERSION - FRAME 1

■ 3P and 4P

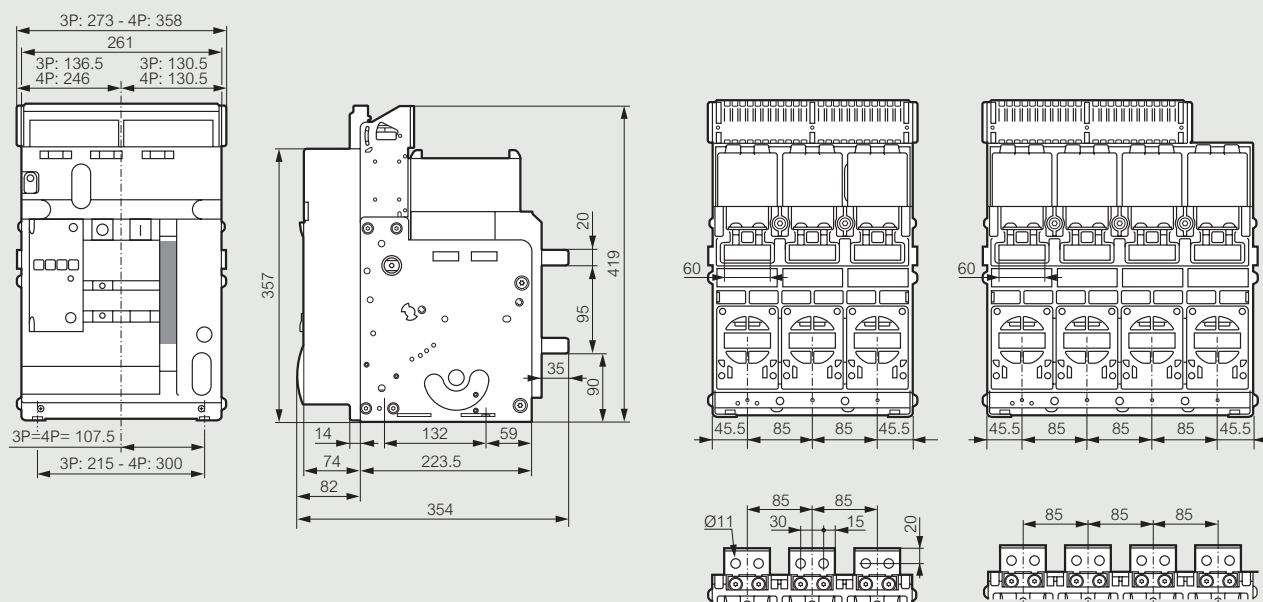

■ Rear terminals for flat connection with bars

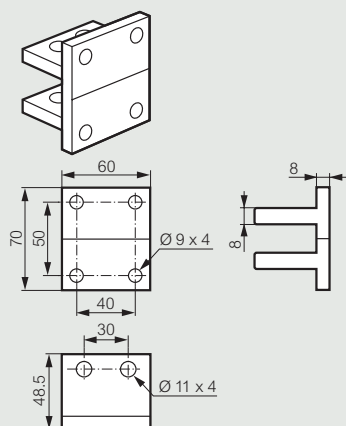

■ Rear terminals for vertical connection with bars

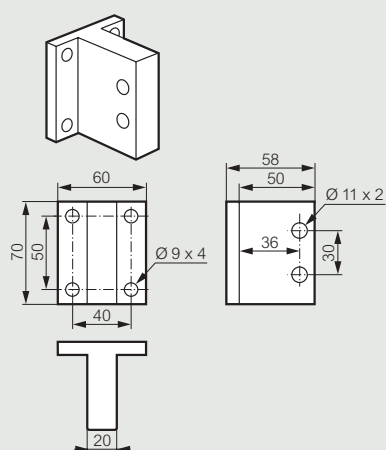

■ Spreaders for flat connection with bars

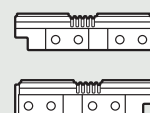
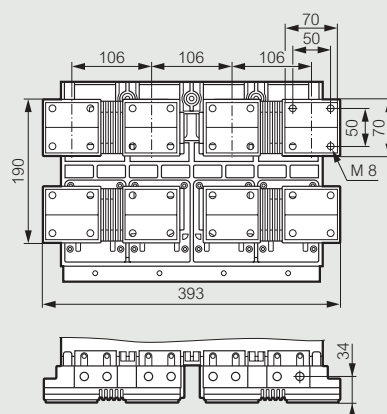
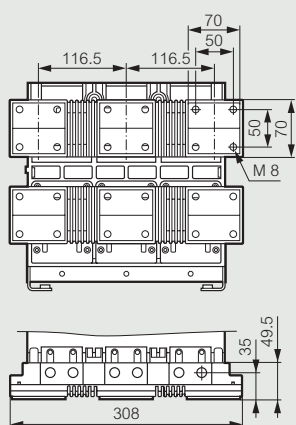

■ Spreaders for vertical connection with bars

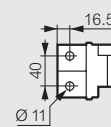
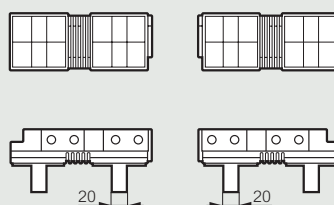
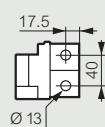
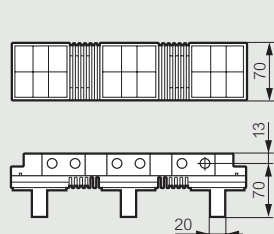

■ Spreaders for horizontal connection with bars

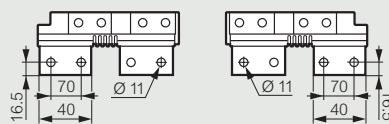
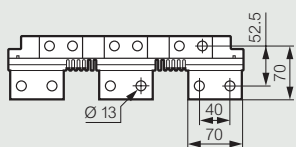
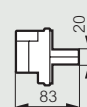
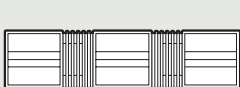

DMX³ air circuit breakers (continued)

2 FIXED VERSION - FRAME 2

■ 3P and 4P

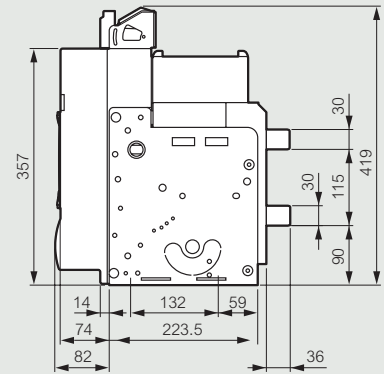
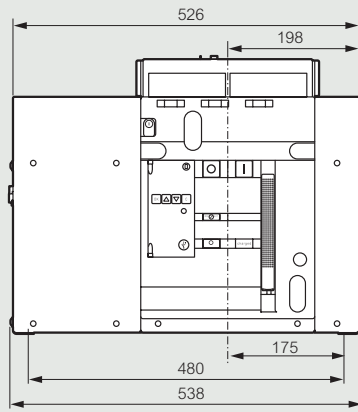
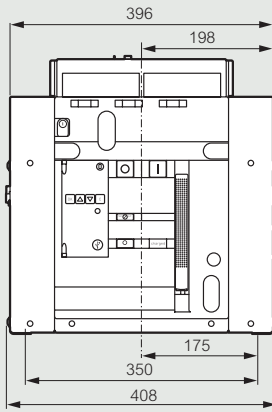

■ Rear terminals for flat connection with bars

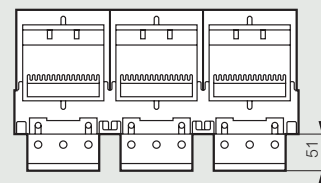
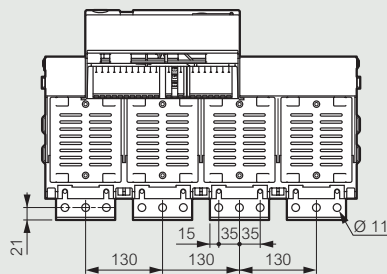
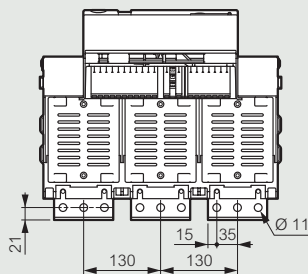
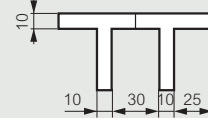
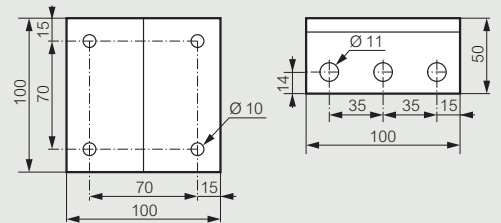
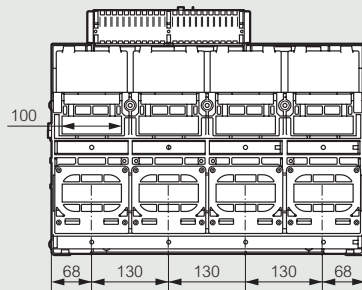
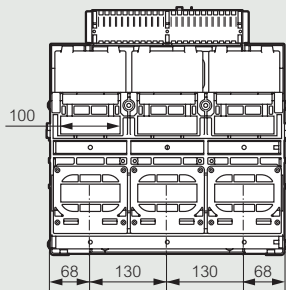

3 DRAW-OUT VERSION - FRAME 1

■ 3P and 4P

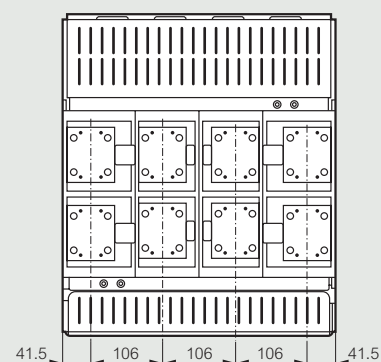
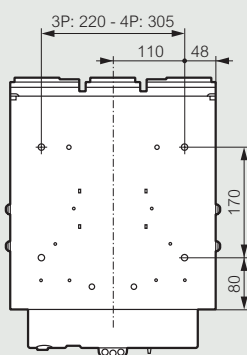
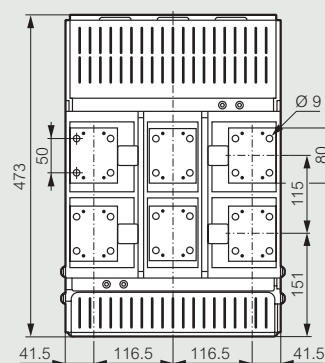
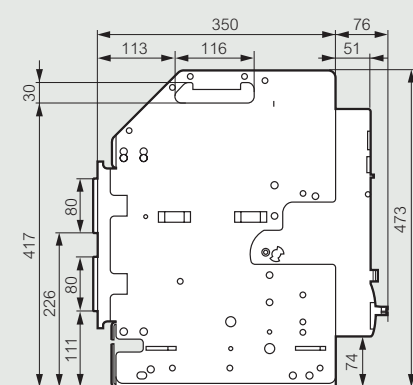
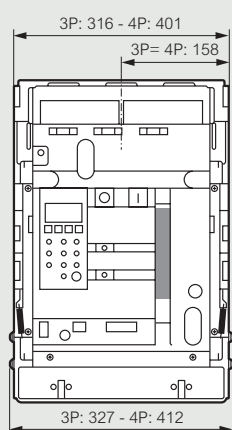

■ Rear terminals for vertical or horizontal connection with bars

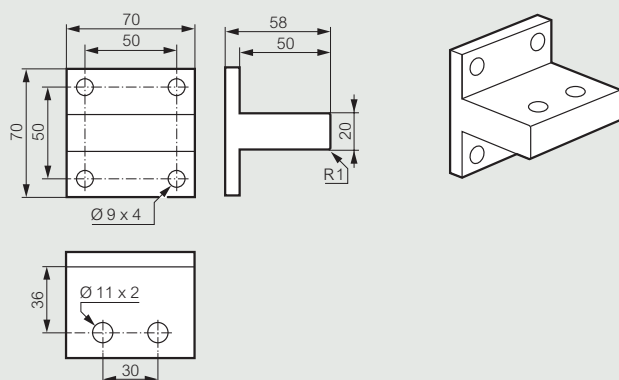

DMX³ air circuit breakers (continued)

4 DRAW-OUT VERSION - FRAME 2

■ 3P and 4P

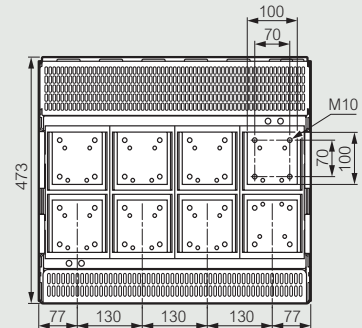
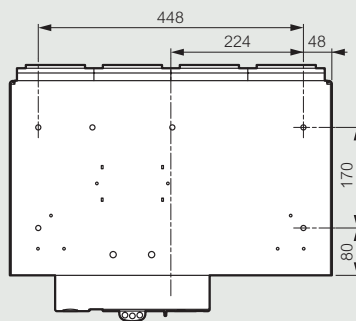
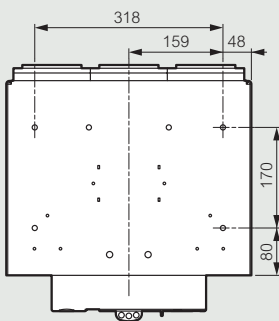
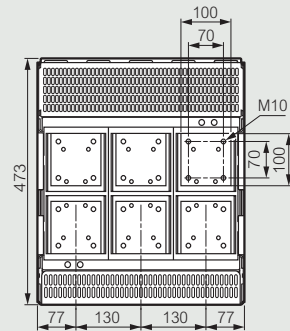
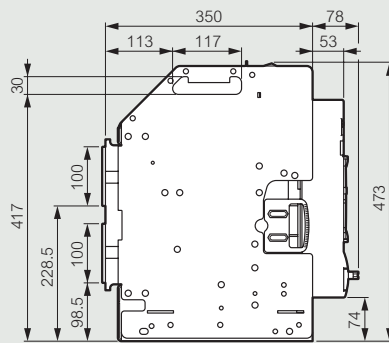
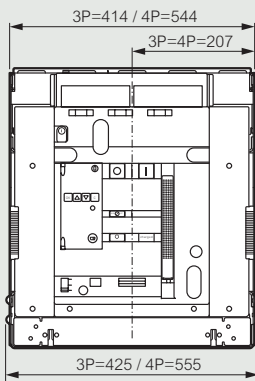

■ Rear terminals for vertical or horizontal connection with bars

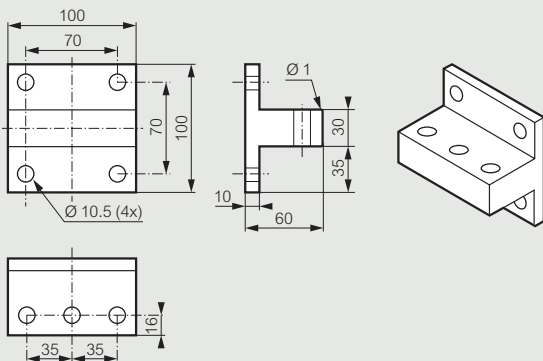

5 CONNECTION OF FIXED VERSION

■ Frame 1

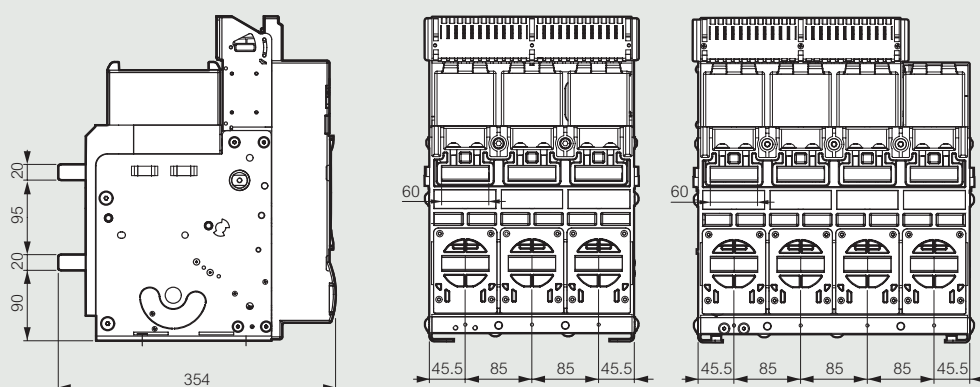

■ Frame 2

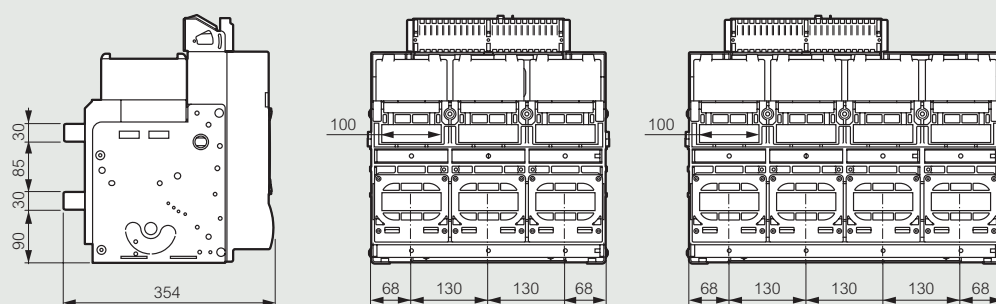

■ Termination support

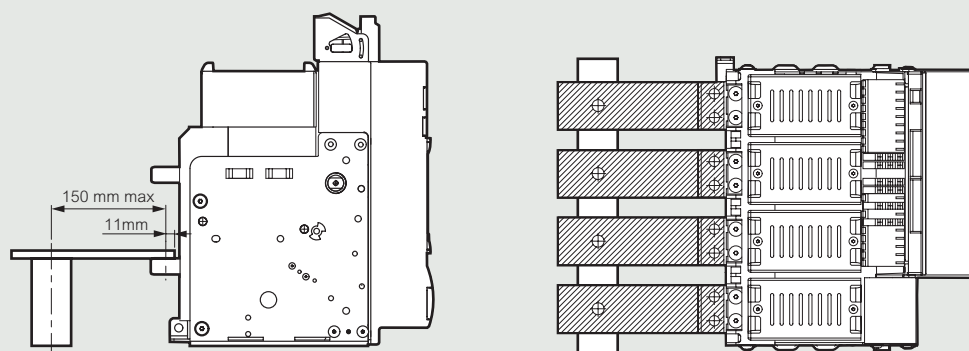

DMX³ air circuit breakers (continued)

6 CONNECTION OF DRAW-OUT VERSION FRAME 1

■ Flat connection

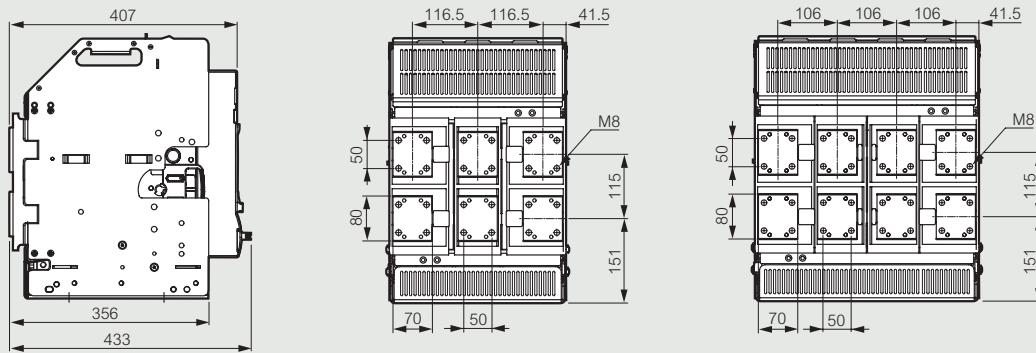

■ Horizontal connection

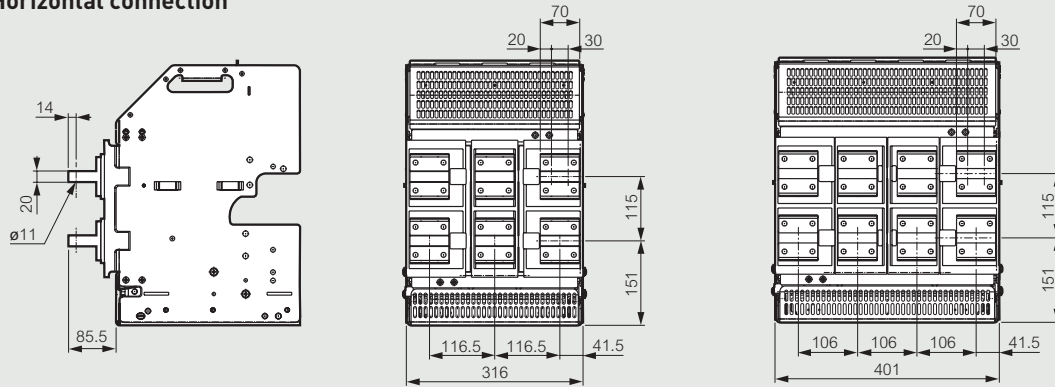

■ Vertical connection

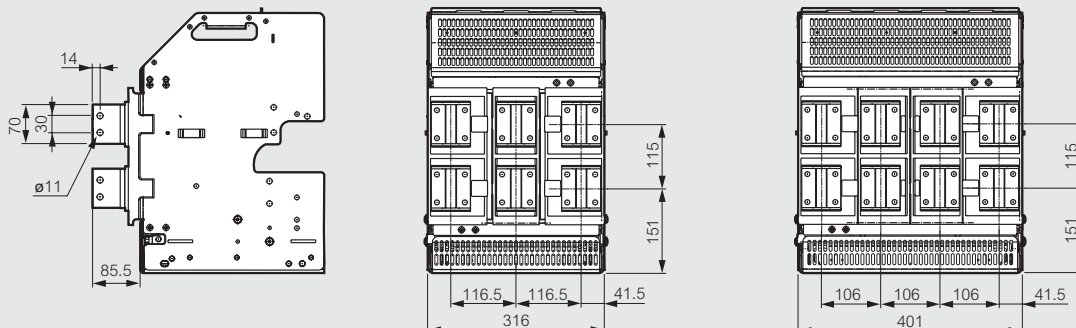

7 CONNECTION OF DRAW-OUT VERSION FRAME 2

■ Flat connection

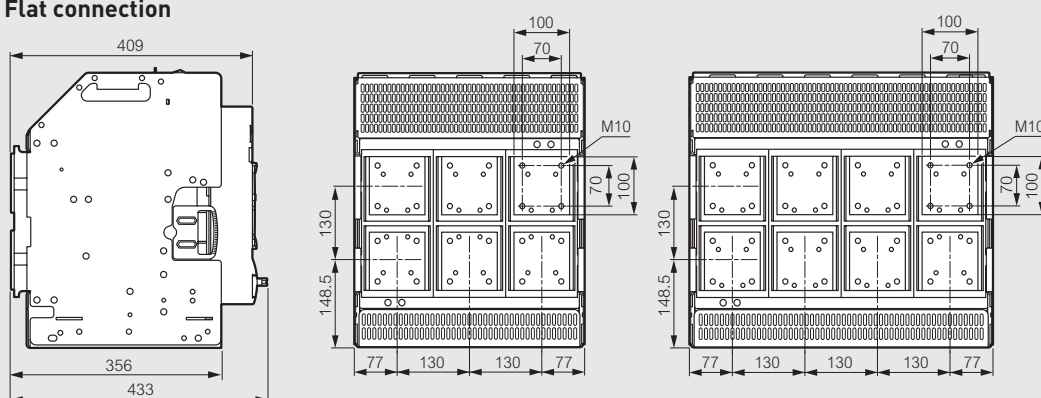

■ Horizontal connection

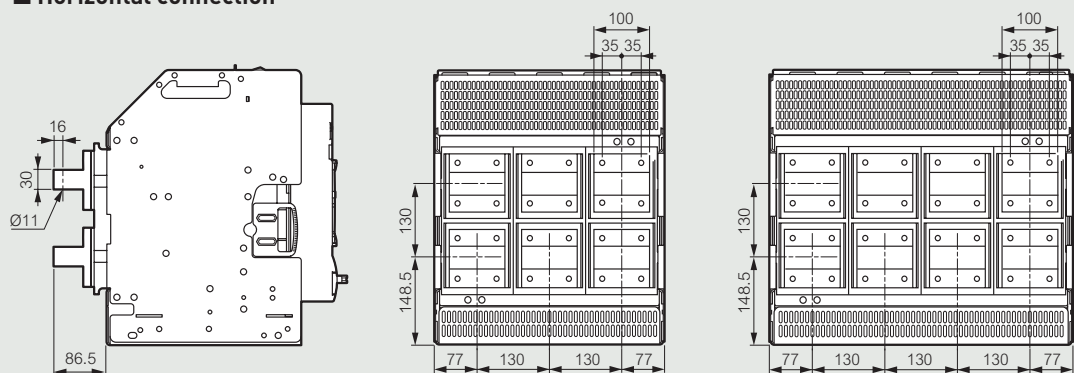

■ Vertical connection

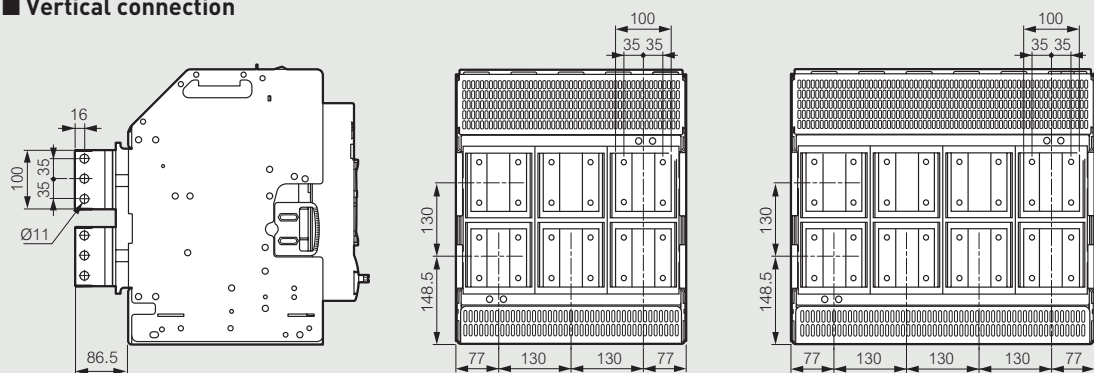

DMX³ air circuit breakers (continued)

8 INSTALLATION OF FIXED VERSION

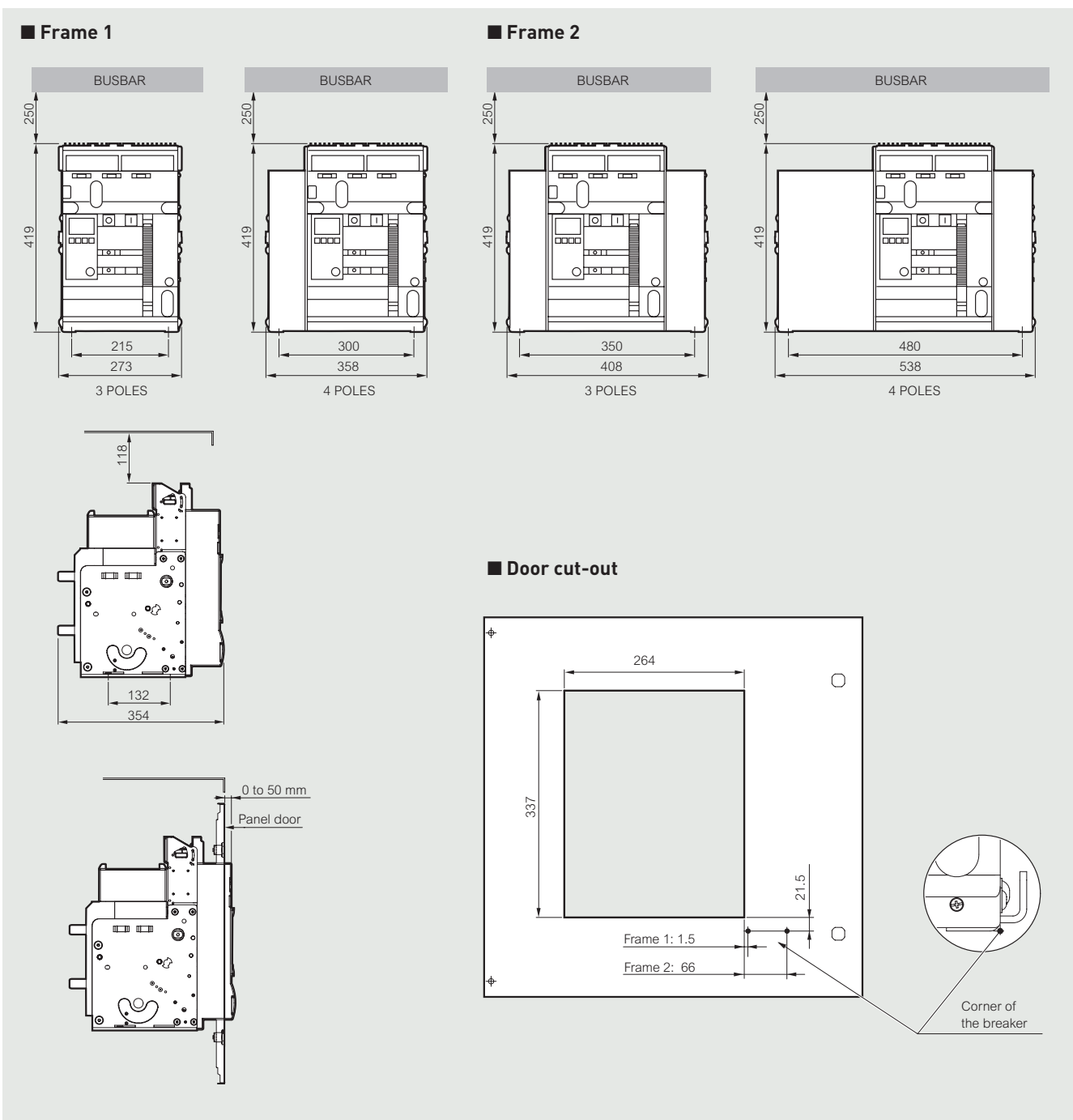

9 INSTALLATION OF DRAW-OUT VERSION

■ Frame 1

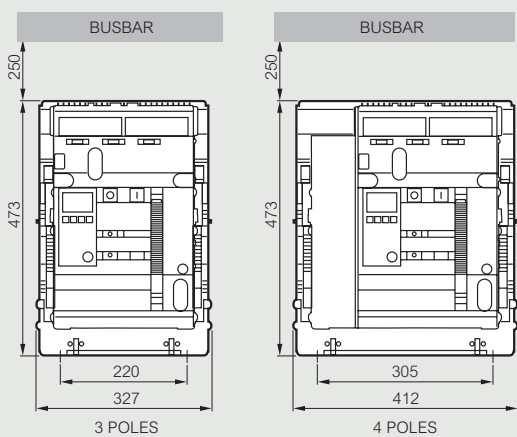

■ Frame 2

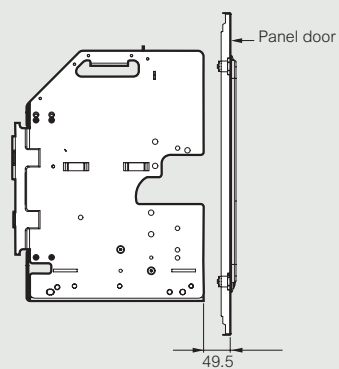
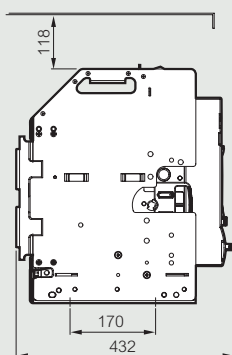
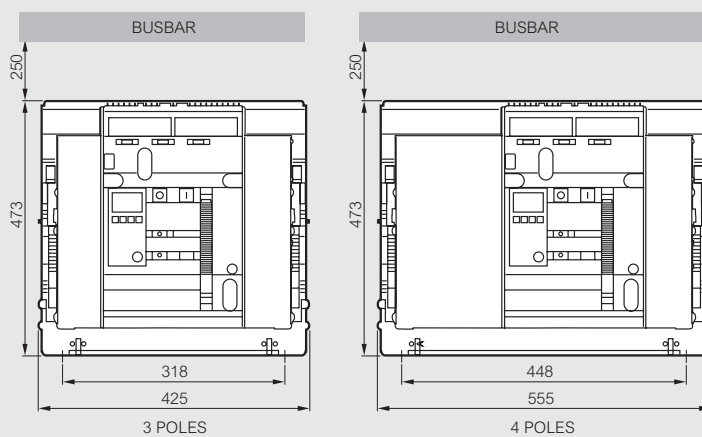

■ Door cut-out

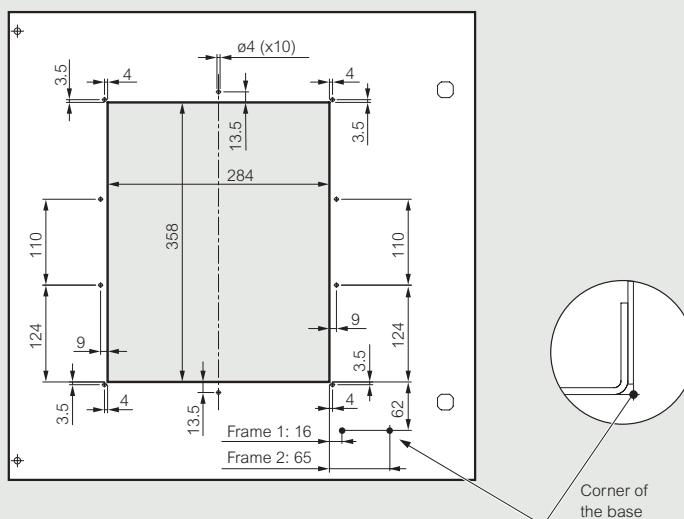

DMX-E air circuit breakers

DMX-E circuit breakers and isolating switches provide protection or control at the head of low voltage distribution installations up to 4000 A.

THE DMX-E RANGE



DMX-E 4000 A 3P fixed version



DMX-E 2500 A 4P draw-out version

The designation of the DMX-E corresponds to its breaking capacity at 415 V AC. So the DMX-E55 offers a breaking capacity (I_{cu} at 415 V AC) of 55 kA, DMX-E 65, DMX-E 80 & DMX-E 100 a breaking capacity of 65 kA, 80 kA & 100 kA respectively. DMX circuit breakers and isolating switches are available in three sizes of device:

- DMX-E 55 & DMX-E 65 up to 1600 A with a breaking capacity of 55 kA & 65 kA
- DMX-E 65 (2000 & 2500 A) & DMX-E 80 (All ratings)
- DMX-E 65 (3200 & 4000 A) & DMX-E 100 (All ratings).

All DMX, both circuit breakers and switches, are available in 3P and 4P arrangement and in fixed and draw-out version.

In comparison with the fixed version, the draw-out version has additional locking facilities, optimum safety when work is being carried out on them (padlocking and physical separation of the installation) or on the installation, and it is easily interchangeable for maintenance purposes (no disconnection to be carried out).



**One catalogue number
= one complete product**

- All breakers are delivered as standard with:
 - MP2G electronic trip unit
 - Auxiliary contacts 4NO+4NC
 - Rear connection
 - Auxiliary terminal block
 - Padlocking shroud for ON and OFF buttons
 - Lifting hooks
 - Panel door seal
- For the draw-out version, the following features are also provided as standard:
 - Safety shutters
 - Racking handle
 - Terminal adaptor

ELECTRONIC TRIP UNITS

DMX-E circuit breakers are equipped with the MP 2G electronic protection unit as standard.

Features of the MP 2G:

- Overload, short-circuit and earth fault protection with adjustable current and time
- Very high current protection
- Switchable thermal reflexivity
- Segregated fault signals
- True RMS measurement

On request, the DMX-E can be equipped with an MP 3 electronic protection unit provided with a high resolution LCD display, additional protection and measurement and communication functions.

MP 2G unit characteristics

Parameters		Settings
Overload	I_r	$I_r = I_n \times \dots$ 0.4 - 0.5 - 0.6 0.7 - 0.75 - 0.8 0.85 - 0.9 0.95 - 1
	T_r	Time delay in s at $6 \times I_r$ 0.5 - 1 - 2 - 4 6 - 8 - 12 - 18 24 - 30
	Neutral protection	$I_N = I_r \times \dots$ 0 % - 50 % - 100 %
Short-circuit	I_s	$I_s = I_n \times \dots$ 0.6 - 1 - 1.5 2 - 3 - 4 - 6 8 - 9 - 10
	T_s	Time delay in ms at $10 \times I_n - I^2t$ Off 20 - 100 - 200 300 - 400 Time delay in ms at $10 \times I_n - I^2t$ On 20 - 100 - 200 - 300 - 400
Instantaneous	I_p	$I_p = I_r \times \dots$ 1.5 - 2 - 3 - 4 5 - 6 - 8 - 10 12 - Max.
Earth fault	I_g	$I_g = I_r \times \dots$ 0.2 - 0.3 - 0.4 0.5 - 0.6
	T_g	Time delay in s I^2t Off 0.1 - 0.2 - 0.3 0.4 - 1 - Off Time delay in s - I^2t On 0.1 - 0.2 - 0.3 0.4
Thermal memory		On/Off

MP 2G electronic protection unit

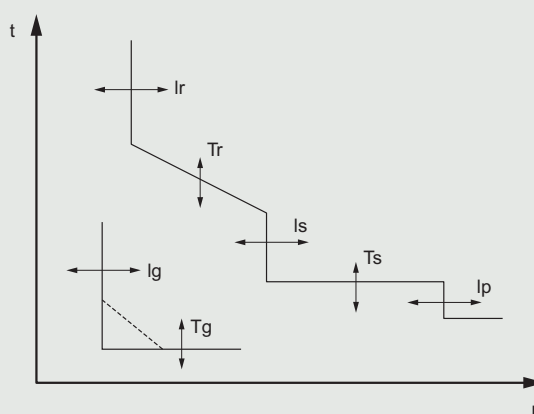
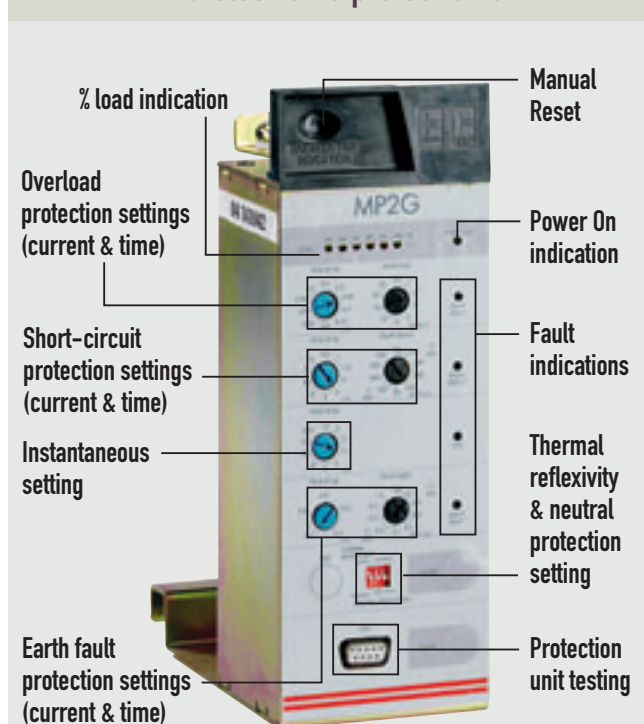

DMX-E air circuit breakers (continued)

TECHNICAL CHARACTERISTICS

DMX-E breakers (According to IEC 60947-2)								
Characteristic	DMX-E 55	DMX-E 65		DMX-E 80		DMX-E 100		
Rated current at 40 °C In (A)	800 - 1000 1250 - 1600	800 - 1000 1250 - 1600	2000 - 2500	2000 - 2500	3200 - 4000	2000 - 2500 3200 - 4000		
Neutral protection	0/50/100%	0/50/100%	0/50/100%	0/50/100%	0/50/100%	0/50/100%		
Rated insulation voltage Ui (V)	1000	1000	1000	1000	1000	1000		
Rated impulse withstand voltage Uimp (kV)	12	12	12	12	12	12		
Rated operational voltage Ue (V)	690	690	690	690	690	690		
Ultimate breaking capacity Icu (kA)	400/415 VA 50/60 Hz	55	65	65	80	80	100	
	500/550 VA 50/60 Hz	50	55	55	70	65	85	
	660/690 VA 50/60 Hz	42	50	50	55	55	75	
Service breaking capacity Ics	400/415 VA 50/60 Hz	100% Icu	100% Icu	100% Icu	100% Icu	100% Icu	100% Icu	
	500/550 VA 50/60 Hz							
	660/690 VA 50/60 Hz							
Short time withstand current Icw (kA)	0.5 s	55	65	65	80	80	100	
	1 s	50	50	55	65	65	70	
	3 s	23	26	35	35	42	50	
Short circuit making capacity Icm (kA)	400/415 VA 50/60 Hz	121	143	143	176	176	220	
	500/550 VA 50/60 Hz	105	121	121	154	154	187	
	660/690 VA 50/60 Hz	88	105	105	121	121	165	
Opening time (ms)	40							
Closing time (ms)	60							
Suitable for isolation	yes	yes	yes	yes	yes	yes		
Dimensions (mm)	Fixed device	Width 3P	347	347	447	447	647	647
		Width 4P	447	447	581	581	847	847
		Depth	335					
		Height	430					
	Draw-out device	Width 3P	347	347	447	447	647	647
		Width 4P	447	447	581	581	847	847
		Depth	421					
		Height	433					
Frame size	I	I	II	II	III	III		

CONTROL ACCESSORIES

1 SHUNT RELEASES

Shunt releases are devices used for remote instantaneous opening of the device.

These devices are available in AC and DC versions, with various supply voltages.

They are simply clipped on to the front panel of the device. No tool is required.

Nominal voltage: 24, 30, 110, 220, 250 V DC, 110, 220, 240, 380, 415 V AC 50/60 Hz

Maximum power consumption: 650 VA

Operating voltage limit: 70% - 110%

2 UNDERVOLTAGE RELEASES

Undervoltage releases are devices which are generally controlled by an NC type contact. They trigger instantaneous opening of the circuit breaker if their supply voltage drops below a certain threshold and in particular if the control contact opens.

These releases are equipped with an energy saving device for limiting their consumption in spite of continuous supply.

They are simply clipped on to the front panel of the device. No tool is required.

Nominal voltage: 24, 30, 110, 220, 250 V DC, 110, 220, 240, 380, 415 V AC 50/60 Hz

Maximum power consumption: 650 VA - 0.5 s

Operating voltage limit: 85% - 110%

3 TIME DELAYED UNDERVOLTAGE RELEASES

These releases are equipped with an electronic device which delays their operation for 3 seconds. They are designed to be used in unstable supplies, where the supply voltage of the release may be subject to variations or micro-breaks, to avoid unwanted opening of the circuit breaker.

They are also equipped with a power saving device for limiting their consumption.

They are simply clipped on to the front panel of the device. No tool is required.

Nominal voltage: 48, 110 V DC, 110, 220, 240, 380, 415 V AC 50/60 Hz

Maximum power consumption: 650 VA - 0.5 s

Operating voltage limit: 85% - 110%

4 CLOSING RELEASES

These coils are used to remotely control the closing of the circuit breaker (the circuit breaker being dependent on the prior loading of the springs). They are controlled by an N/O type contact.

They are simply clipped on to the front panel of the device. No tool is required.

Nominal voltage: 24, 30, 110, 220, 250 V DC, 110, 220, 240, 380, 415 V AC 50/60 Hz

Maximum power consumption: 650 VA

Operating voltage limit: 85% - 110%

5 MOTOR OPERATORS

Motor operators, which are available in different voltages, are used for remotely charging the closing springs of the circuit breaker.

Combined with an opening release (shunt trip or undervoltage release) and a closing release, they can thus be used for remotely controlling the circuit breaker.

They are easy to mount, with three screws.

Nominal voltage: 24, 30, 48, 60, 110, 125, 250 V DC, 110, 220, 240, 380, 415 V AC 50/60 Hz

Maximum power consumption: 300 VA

Operating voltage limit: 85% - 110%

Number of control auxiliaries for DMX-E

Shunt release	1
Undervoltage release or delayed undervoltage release	1
Closing release	1

DMX-E air circuit breakers (continued)

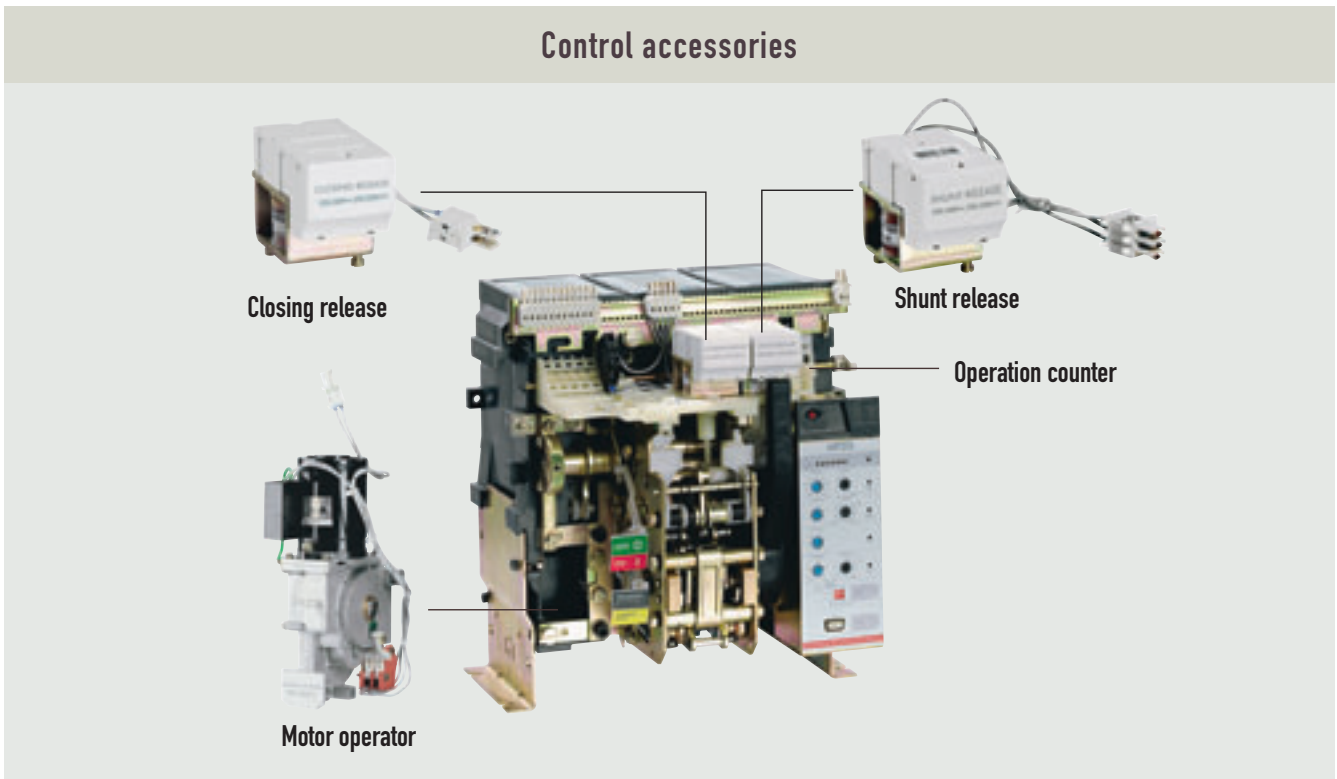

SIGNALLING CONTACTS

1 FAULT SIGNAL CONTACTS

All DMX-E are equipped as standard with 8 auxiliary contacts (4NO+4NC). A fault signal contact can be added to indicate a fault trip (Cat.No 626317). This contact remains closed

+

“Ready to Close” contact

This switch changes state when:

- All arc chambers are secured
- Undervoltage release is energised
- Closing spring is charged
- Racking shutter is closed
- Shunt release is de-energised
- Breaker or switch is in Off condition

until the device is reset. They are simply clipped on to the front panel of the device. No tool is required. A shunt release action and undervoltage release action signal contact (Cat.Nos 626315 & 626316) can also be added to provide indication of tripping due to the shunt release or undervoltage release respectively. This contact remains closed until the device is reset. Finally, DMX-E devices can be equipped with a “Ready to close” contact (Cat.No 626318).

2 POSITION INDICATING CONTACTS

An additional block of 8 changeover contacts (Cat.No 626311) can be fitted on the draw-out versions to indicate the position of the device in its base (connected / test / isolated).

PADLOCKING AND MECHANICAL ACCESSORIES

DMX-E circuit breakers and switches draw-out types are delivered as standard with safety padlocking shutters preventing access to live terminals. They have a number of other safety devices.

> Using padlocks

- ON/OFF buttons
- Racking shutter
- Access to the protection unit settings

> By key-operated lock

- Main contacts open
- Isolated position (2 different locks possible)

> By cable interlocking, for supply inversion (see below)

The DMX-E devices can be equipped with an operation counter (Cat.No 26324). Its counts the total number of operations (cycles).

For draw-out breakers or switches, a mis-insertion device can be used to prevent the insertion of a draw-out breaker into an incompatible base.



Fixed to draw-out conversion

A fixed breaker can easily be converted into a draw-out breaker. It just requires an empty base and a set of rear terminals.



Base for draw-out device

SUPPLY INVERTERS

The cable mechanical interlock is used to interlock breakers according to the desired control scheme. It can interlock 2 or 3 devices, which may not be of the same type (3P, 4P, fixed, draw-out, mixed) in a vertical or horizontal configuration.

The interlock units are mounted on the right-hand side of the device.

> Possible mounting arrangements

(cable length: 2 meters)

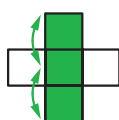

Vertical



Horizontal

Type of Interlock	Typical circuit	Interlocks possible	Schematic diagram															
Two Incomers		<table border="1"><tr><td>A</td><td>B</td></tr><tr><td>O</td><td>O</td></tr><tr><td>I</td><td>O</td></tr><tr><td>O</td><td>I</td></tr></table>	A	B	O	O	I	O	O	I	 Cable length : 2 meters, min. Radius at cable bend : 70 mm							
A	B																	
O	O																	
I	O																	
O	I																	
Three Incomers		<table border="1"><tr><td>A</td><td>B</td><td>C</td></tr><tr><td>O</td><td>O</td><td>O</td></tr><tr><td>I</td><td>O</td><td>O</td></tr><tr><td>O</td><td>I</td><td>O</td></tr><tr><td>O</td><td>O</td><td>I</td></tr></table>	A	B	C	O	O	O	I	O	O	O	I	O	O	O	I	 Cable length : 2 meters, min. Radius at cable bend : 70 mm
A	B	C																
O	O	O																
I	O	O																
O	I	O																
O	O	I																
Two Incomers One Standby		<table border="1"><tr><td>A</td><td>B</td><td>C</td></tr><tr><td>O</td><td>O</td><td>O</td></tr><tr><td>I</td><td>O</td><td>O</td></tr><tr><td>O</td><td>I</td><td>O</td></tr><tr><td>O</td><td>O</td><td>I</td></tr></table>	A	B	C	O	O	O	I	O	O	O	I	O	O	O	I	 Cable length : 2 meters, min. Radius at cable bend : 70 mm
A	B	C																
O	O	O																
I	O	O																
O	I	O																
O	O	I																
Two Incomers One BusCoupler		<table border="1"><tr><td>A</td><td>B</td><td>C</td></tr><tr><td>O</td><td>O</td><td>O</td></tr><tr><td>I</td><td>O</td><td>O</td></tr><tr><td>O</td><td>I</td><td>O</td></tr><tr><td>O</td><td>O</td><td>I</td></tr></table>	A	B	C	O	O	O	I	O	O	O	I	O	O	O	I	 Cable length : 2 meters, min. Radius at cable bend : 70 mm
A	B	C																
O	O	O																
I	O	O																
O	I	O																
O	O	I																

O - Breaker Open I - Breaker Closed

DMX-E air circuit breakers (continued)

CONNECTION

Correctly sized connections are essential for the reliability of installations and in particular for high power equipment. DMX-E devices and switches have generously sized connection plates. Fixed devices are delivered with fixed rear horizontal connections while draw-out types are delivered with adjustable

rear terminals (except 2000 and 2500 A). Terminals accept aluminium cables and bars. It is recommended that the first busbar support is placed a maximum of 100 mm from the back of the breaker.

■ Connection Fixed version 3 P/4 P

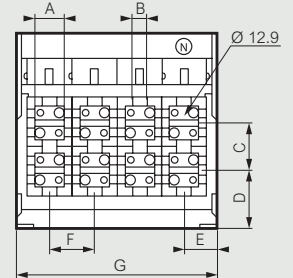
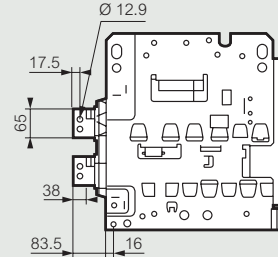
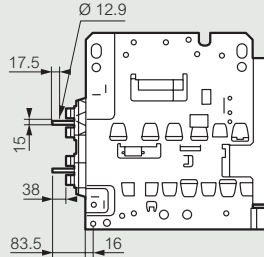
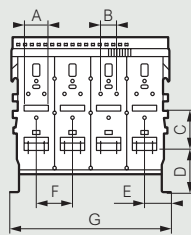
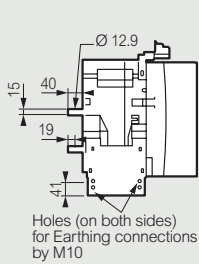

	Up to 1600 A				From 2000 to 2500 A				From 3200 to 4000 A			
	Fixed		Draw-out		Fixed		Draw-out		Fixed		Draw-out	
	3P	4P	3P	4P	3P	4P	3P	4P	3P	4P	3P	4P
A	65	65	65	65	98	98	98	98	65	65	65	65
B	40	40	27	27	28	28	27	27	40	40	27	27
C	105	105	105	105	105	105	105	105	105	105	105	105
D	122	122	129	129	122	122	129	129	122	122	129	129
E	73.5	73.5	73.5	73.5	90	90	90	90	73.5	73.5	73.5	73.5
F	100	100	100	100	133.3	133.3	133.3	133.3	100	100	100	100
G	347	447	347	447	447	581	447	581	647	847	647	847



Connections: a few recommendations!

Connections provide the electrical connection of equipment and are also responsible for a considerable proportion of their heat dissipation. Connections must never be under-sized. Plates or terminals must be used over a maximum area. Heat dissipation is encouraged by arranging the bars vertically. If an uneven number of bars is connected, place the higher number of bars on the upper part of the terminal. Avoid bars running side by side: this causes poor heat dissipation and vibrations. Place spacers between the bars to maintain a distance between them which is at least equivalent to their thickness.

TRIPPING CURVE

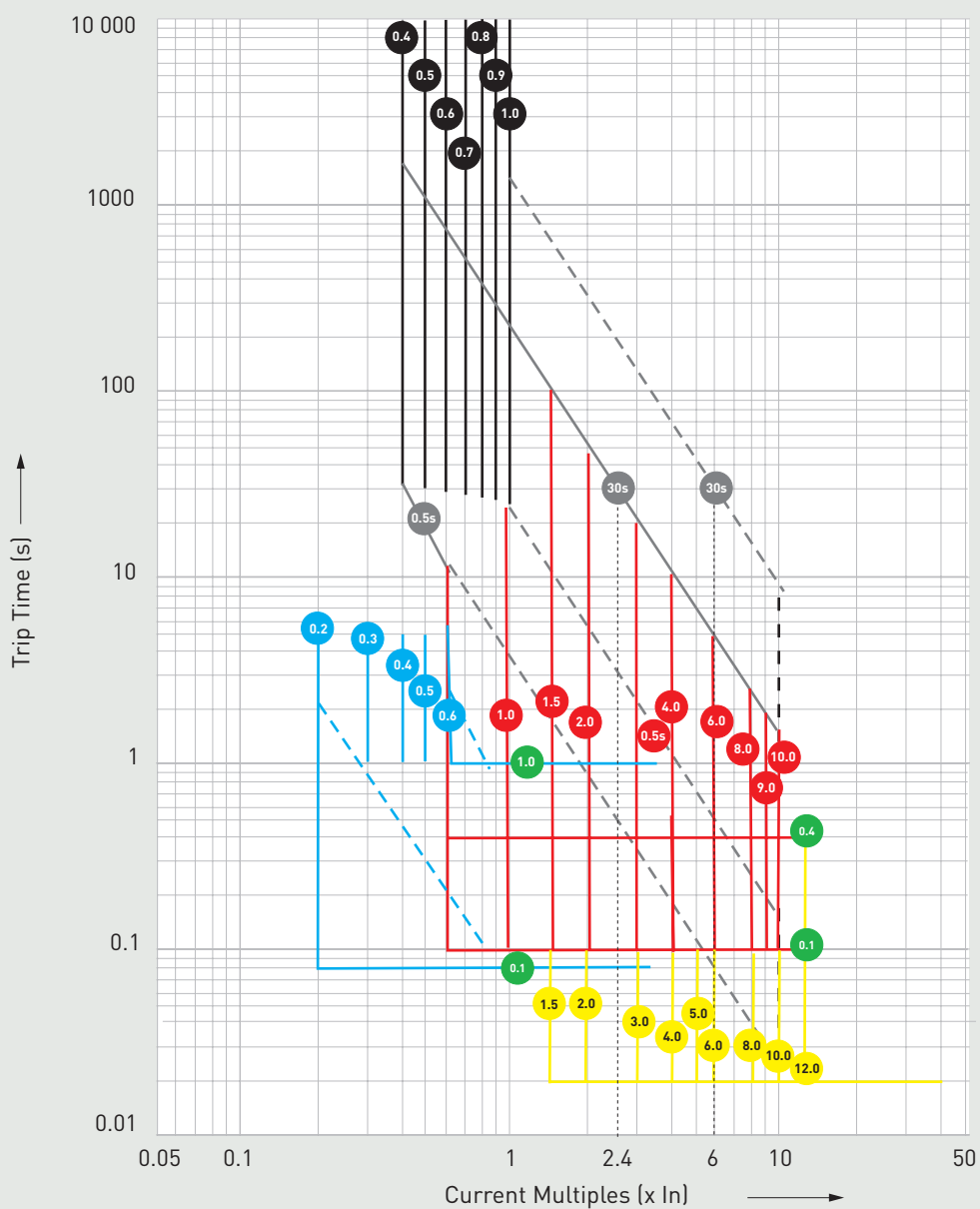

DMX-E air circuit breakers (continued)

DIMENSIONS

■ DMX-E up to 1600 A
Fixed version
3 P

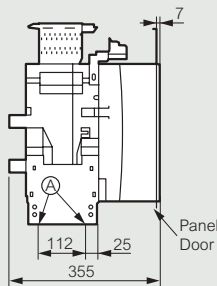
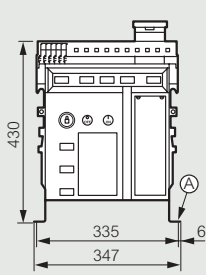

4 P

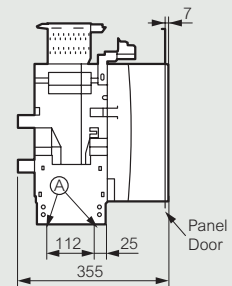
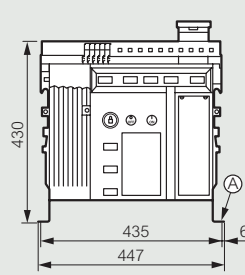

Draw-out version
3 P

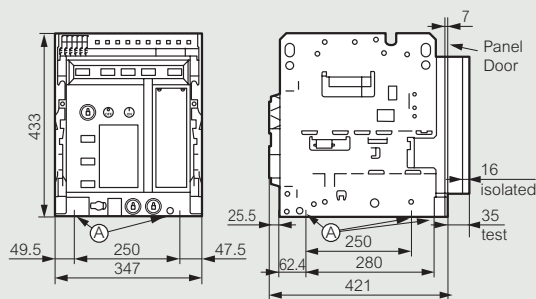

4 P

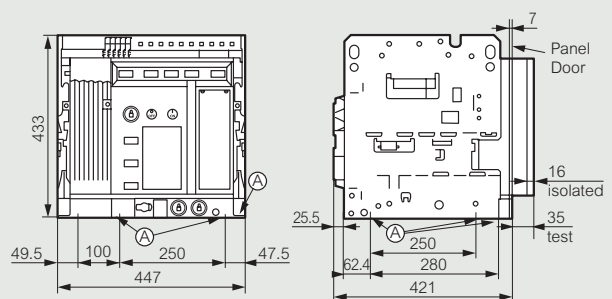

(A) Fixing holes suitable for M10

■ DMX-E from 2000 to 2500 A
Fixed version
3 P

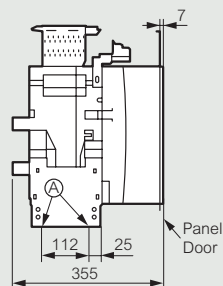
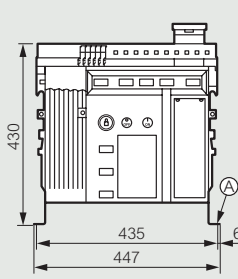

4 P

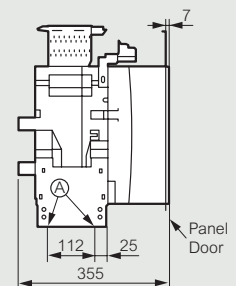
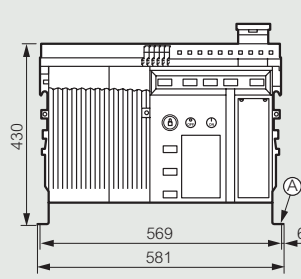

**Draw-out version
3 P**

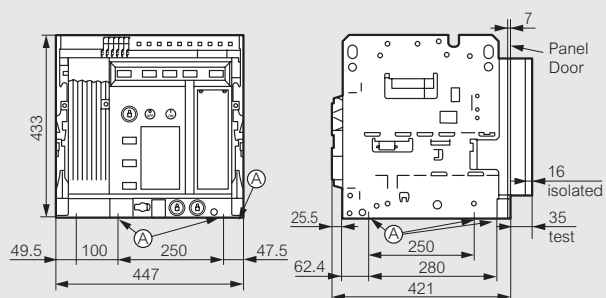

4 P

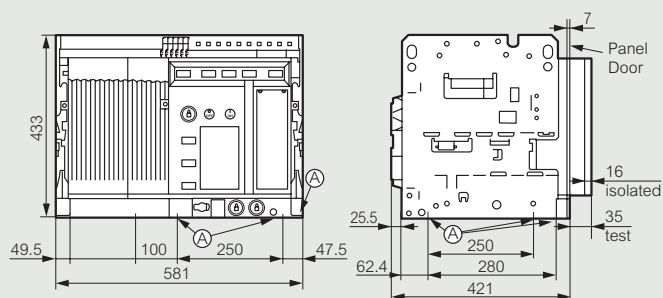

■ **DMX-E from 3200 to 4000 A**

**Fixed version
3 P**

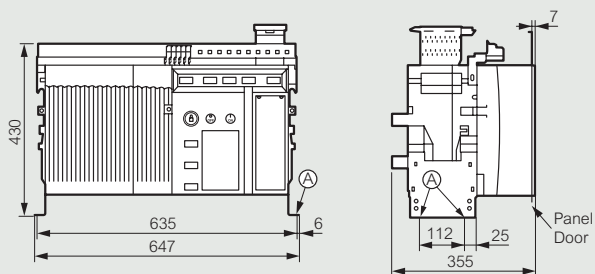

4 P

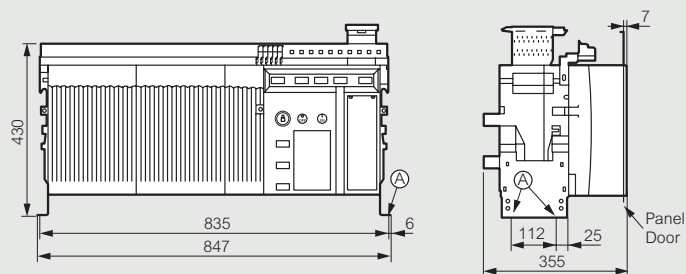

**Draw-out version
3 P**

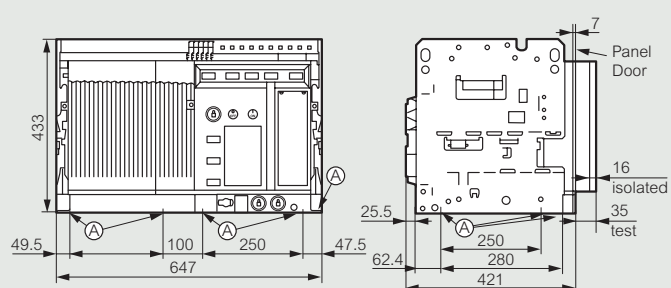

4 P

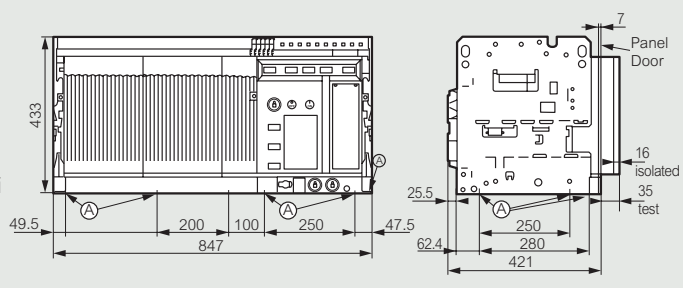







DPX moulded case circuit breakers

DPX “moulded case circuit breakers” offer optimum solutions for the protection requirements of commercial and industrial installations.

They can be installed:

- On  rail or plate up to 250 A
- On plate up to 1600 A

THE DPX RANGE

Mounting on  rail (or plate) with modular faceplate			Mounting on plate with special faceplate		
					
DPX 125	DPX 160	DPX 250 ER	DPX 250	DPX 630	DPX 1600
Thermal-magnetic releases			Thermal-magnetic and electronic releases		
Ratings from 16 to 250 A			Ratings from 63 to 1600 A		

Circuit breakers are available in thermal magnetic and electronic versions with nominal currents from 16 to 1600 A and breaking capacities from 16 to 70 kA. The main characteristics of DPX circuit breakers are their optimised dimensions, their ease of installation, use and accessorisation, and their undisputed reliability.



DPX 125, 160 and 250 ER and their side-mounted earth leakage modules can be installed on a  rail and under a modular faceplate with window.

Height spacer Cat. No. 262 99 can be used to combine modular circuit breakers and DPX on the same rail.

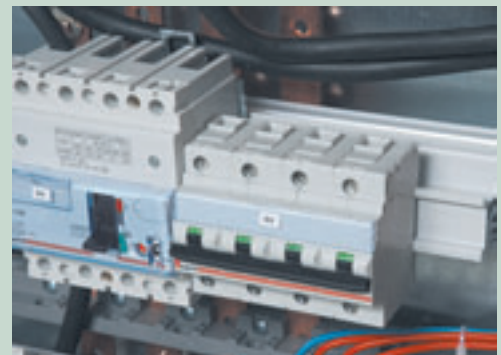

The DPX range also includes DPX-I trip-free circuit breakers (see p. 121)

1 THERMAL MAGNETIC DPX

Circuit breakers equipped with thermal magnetic releases are used to set the thermal intervention thresholds for protection against overloads and the magnetic intervention thresholds for protection against short-circuits.

The magnetic threshold setting option is available on all devices from the DPX 250 upwards. This threshold is fixed on equipment for DIN rail mounting (DPX 125, DPX 160 and DPX 250 ER).

Thermal magnetic DPXs are available from 16 to 1250 A with breaking capacities from 16 to 70 kA.

2 ELECTRONIC DPX

DPXs equipped with microprocessor-based electronic releases offer the option, depending on the version, of precise setting of both the time and current intervention thresholds for overloads, short-circuits and also for earth faults.

Electronic DPXs are available from 40 to 1600 A with breaking capacities from 36 to 100 kA.

Electronic releases are available in 2 versions:

- S1: adjustment of I_r and I_m
- S2: adjustment of I_r , T_r , I_m and T_m

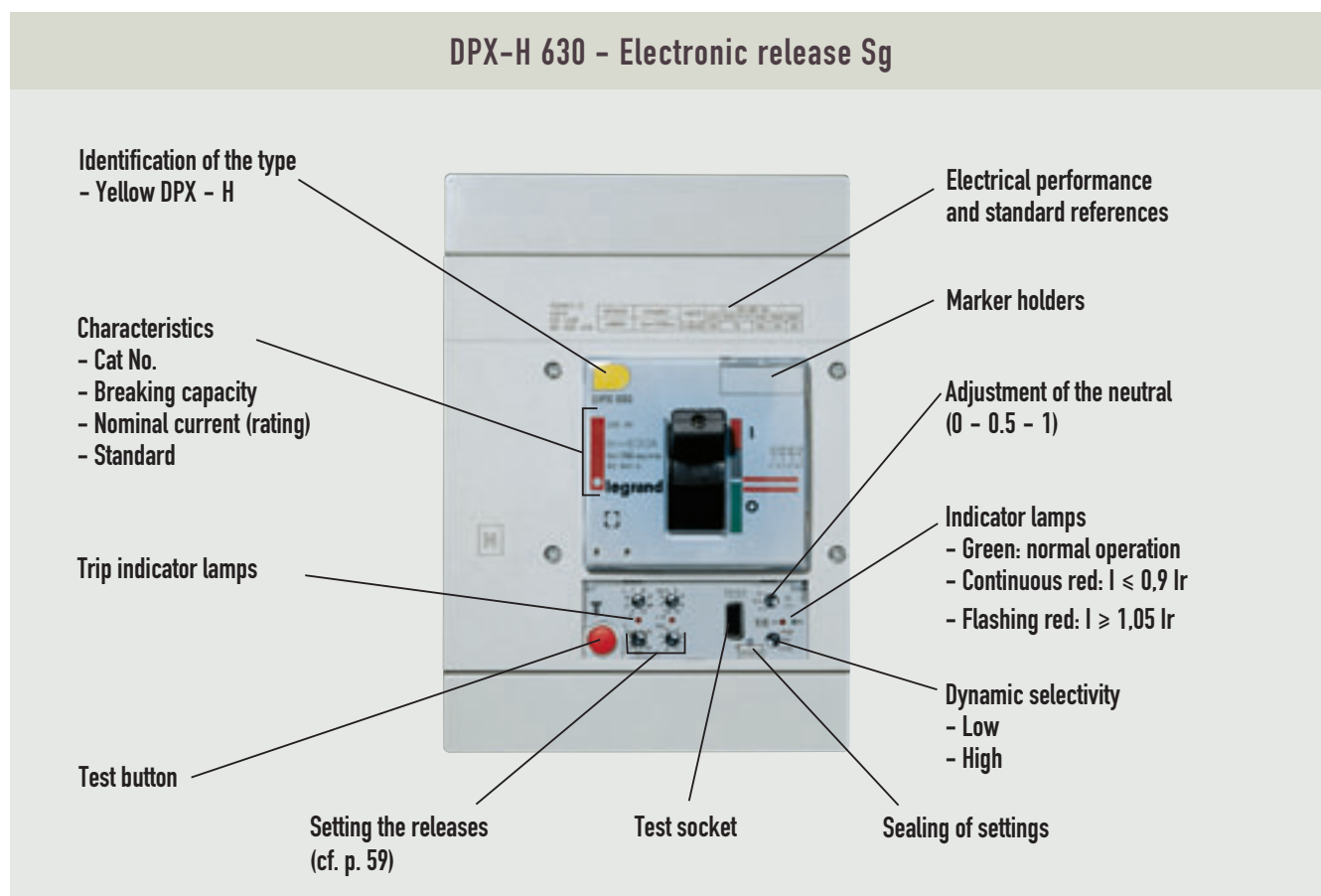

DPX moulded case circuit breakers (continued)

CHARACTERISTICS

		DPX-E 125 DPX 125				DPX 160			DPX 250 ER		
Number of poles		1P	3P - 4P - 3P+N/2			3P - 4P - 3P+N/2			3P - 4P - 3P+N/2		
Type of MCCB		16 kA	16 kA	25 kA	36 kA	25 kA	36 kA	50 kA	25 kA	36 kA	50 kA
Nominal rating I _n (A)		16-125	16-125	16-125	16-125	63-160	63-160	40-160	100-250	100-250	100-250
Rated insulation voltage U _i (V)		290	500	500	500	500	500	500	500	500	500
Rated impulse withstand voltage U _{imp} (kV)		6	6	6	6	6	6	6	6	6	6
Rated operating voltage U _e (V)	AC 50/60 Hz	230	500	500	500	500	500	500	500	500	500
	DC ⁽¹⁾		250	250	250	250	250	250	250	250	250
Ultimate breaking capacity I _{cu} (kA)	230/240 V AC	16	22	35	40	40	50	65	40	50	65
	400/415 V AC		16	25	36	25	36	50	25	36	50
	440 V AC		10	18	20	20	25	30	20	25	30
	480/500 V AC		8	12	14	10	12	15	10	12	15
	600 V AC										
	690 V AC										
2 poles in series	250 V DC ⁽¹⁾		16	25	30	25	36	45	25	36	45
Service breaking capacity I _{cs} [% I _{cu}]		50	100	50	75	100	75	50	100	75	50
Rating closing capacity on short circuit I _{cm} (kA) at 400 V AC		32	32	52.5	75.6	52.5	75.6	105	52.5	75.6	105
Category of use		A	A	A	A	A	A	A	A	A	A
Isolation capability		•	•	•	•	•	•	•	•	•	•
Release	thermal magnetic	•	•	•	•	•	•	•	•	•	•
	electronic S1										
	electronic S2										
Earth leakage modules ⁽²⁾	side by side		•	•	•	•	•	•	•	•	•
	underneath		•	•	•	•	•	•	•	•	•
Endurance (o.c. cycle)	mechanical		25000	25000	25000	20000	20000	20000	20000	20000	20000
	electrical (at I _n)		8000	8000	8000	8000	8000	8000	8000	8000	8000
	electrical (at 0.5 I _n)		10000	10000	10000	10000	10000	10000	10000	10000	10000
Dimensions L x H x D (mm)	1P	25 x 120 x 74									
	3P		75.6 x 120 x 74			90 x 150 x 74			90 x 176 x 74		
	4P		101 x 120 x 74			120 x 150 x 74			120 x 176 x 74		
Weight (kg)	3P		1			1.2			1.2		
	4P		1.2			1.6			1.6		

(1) For voltages greater than 250 V DC: please contact us

(2) Above 630 A, use of a relay with separate cores

DPX 250		DPX 250 electronic		DPX 630		DPX 630 electronic			DPX 1250		DPX 1600 electronic	
3P - 4P - 3P+N/2		3P - 4P - 3P+N/2		3P - 4P - 3P+N/2		3P - 4P - 3P+N/2			3P - 4P - 3P+N/2		3P - 4P - 3P+N/2	
36 kA	70 kA	36 kA	70 kA	36 kA	70 kA	36 kA	70 kA	100 kA	50 kA	70 kA	50 kA	70 kA
40-250	40-250	40-250	40-250	250-630	320-630	250-630	400-630	400-630	800-1250	800-1250	800-1600	800-1600
690	690	690	690	690	690	690	690	690	690	690	690	690
8	8	8	8	8	8	8	8	8	8	8	8	8
690	690	690	690	690	690	690	690	690	690	690	690	690
250	250	-	-	250	250	-	-	-	250	250	-	-
60	100	60	100	60	100	60	100	170	80	100	80	100
36	70	36	70	36	70	36	70	100	50	70	50	70
30	60	30	60	30	60	30	60	70	45	65	45	65
25	40	25	40	25	40	25	40	45	35	45	35	45
20	25	20	25	20	25	20	25	28	25	35	25	35
16	20	16	20	16	20	16	20	22	20	25	20	25
36	40			36	40				50	50		
100	75	100	75	100	75	100	75	50	100	75	100	75
75.6	154	75.6	154	75.6	154	75.6	154	220	105	154	105	154
A	A	A	A	A	A	A(250-400) / B(630 A)			A	A	A	A
•	•	•	•	•	•	•	•	•	•	•	•	•
•	•			•	•				•	•		
		•	•			•	•				•	•
		•	•			•	•	•			•	•
•	•	•	•	•	•	•	•	•				
20000	20000	20000	20000	15000	15000	15000	15000	15000	10000	10000	10000	10000
8000	8000	8000	8000	5000	5000	5000	5000	5000	4000	4000	3000	3000
10000	10000	10000	10000	8000	8000	8000	8000	8000	8000	8000	6000	6000
105 x 200 x 105		105 x 200 x 105		140 x 260 x 105		140 x 260 x 105			210 x 320 x 140		210 x 320 x 140	
140 x 200 x 105		140 x 200 x 105		183 x 260 x 105		183 x 260 x 105			280 x 320 x 140		280 x 320 x 140	
2.5		2.5		from 4.5 to 5.8		from 5.3 to 5.8			18		18	
3.7		3.7		from 6.4 to 7.4		from 6.8 to 7.4			23.4		23.4	

DPX moulded case circuit breakers (continued)

RELEASES

Thermal-magnetic DPX adjustment ranges

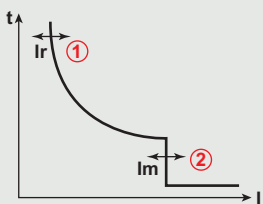
	DPX 125	DPX 160 DPX 250 ER	DPX 250	DPX 630	DPX 1600
					
① Trip threshold for overloads: I_r (thermal)	0.7 to 1 I_n	0.64 to 1 I_n	0.64 to 1 I_n	0.8 to 1 I_n	0.8 to 1 I_n
② Trip threshold for short circuits: I_m (magnetic)	Fixed: 10 I_n (100 and 125 A)	Fixed: 10 I_n	3.5 to 10 I_n	5 to 10 I_n	5 to 10 I_n

Electronic DPX adjustment ranges

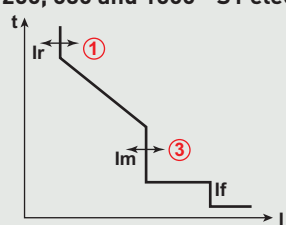
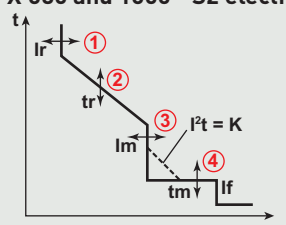
	DPX 250, 630 and 1600 - S1 electronic	DPX 630 and 1600 - S2 electronic
Settings		
① Trip threshold for overloads: I_r (long delay)	[0.4 - 0.5 - 0.6 - 0.7 - 0.8 - 0.85 - 0.9 - 0.95 - 1] x I_n	
② Long delay operation time: T_r	Fixed: 5 s (for $I = 6 \times I_r$)	5 - 10 - 20 - 30 s (for $I = 6 \times I_r$)
③ Trip threshold for short circuits: I_m (short delay)	[1.5 - 2 - 2.5 - 3 - 4 - 5 - 6 - 8 - 10] x I_r	
④ Short delay operation time: T_m	Fixed: 0.05 s	0 - 0.1 - 0.2 - 0.3 s
I^2t constant	No	Yes (T_m : 0.01 - 0.1 - 0.2 - 0.3 s)
Fixed instantaneous protection: I_f	DPX 250: 4 kA DPX 630: 5 kA DPX 1600: 10 kA (630 - 800 A); 15 kA (1250 A); 20 kA (1600 A)	
Neutral protection	[0 - 0.5 - 1] x I_n	
Thermal memory	No	Yes
Dynamic discrimination	Low/high	
Logical discrimination	No	Yes

Adjustment panels on releases

■ Thermal-magnetic releases

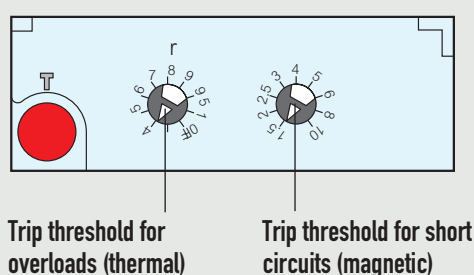

■ Electronic releases

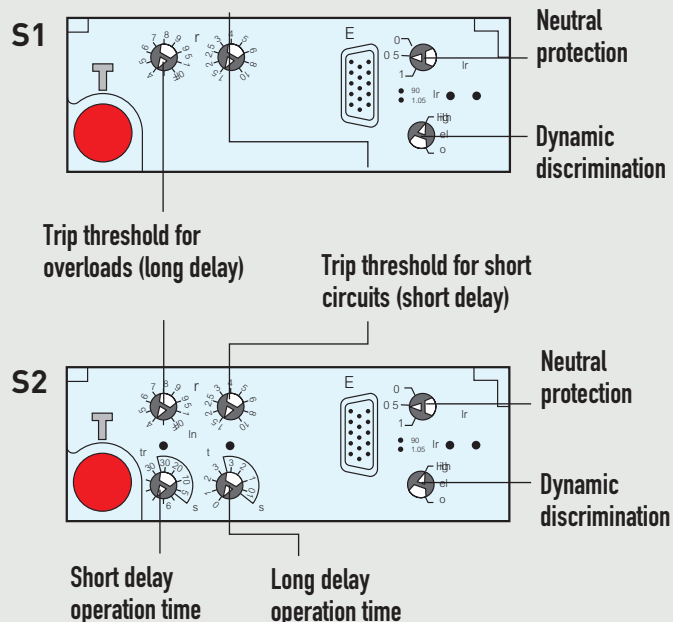

Advanced functions

The electronic releases of DPX have a number of innovative additional functions, depending on the model.

- **Thermal memory:** in the context of “long delay” protection, the release memorises the image of the temperature rise produced by an overload. This “thermal memory” is refreshed regularly if no other overload occurs. However, if there are successive overloads, the effects are cumulative and the operation time of the device will be proportionally reduced. Protection of the cable is thus maintained.
- **Setting of the neutral current on the front panel** (0%, 50%, 100% of the phase current).
- **Dynamic selectivity:** makes use of the performance of 2 devices in series.

- **Logical selectivity:** a special link between two devices can be used to assign an additional 50 ms delay to the device installed upstream in order to give the downstream device time to break the circuit (total selectivity).
- **Load shedding function:** when a device is crossed by a current greater than 105% of I_r it is possible, using the output contacts, to shed the non-priority circuits. The load shedding information is cancelled when the device’s load returns to less than 85% of I_r .
- **Signalling of the load on the device via LEDs on the front panel** (green: normal; red continuous: $I \geq 0.9 I_r$. Red flashing: $I \geq 1.05 I_r$).
- **Connector on front panel for connecting a PC.**
- **Self-protection if there is a microprocessor problem.**

DPX moulded case circuit breakers (suite)

MOUNTING, ACCESSORIES AND CONNECTION OF DPX

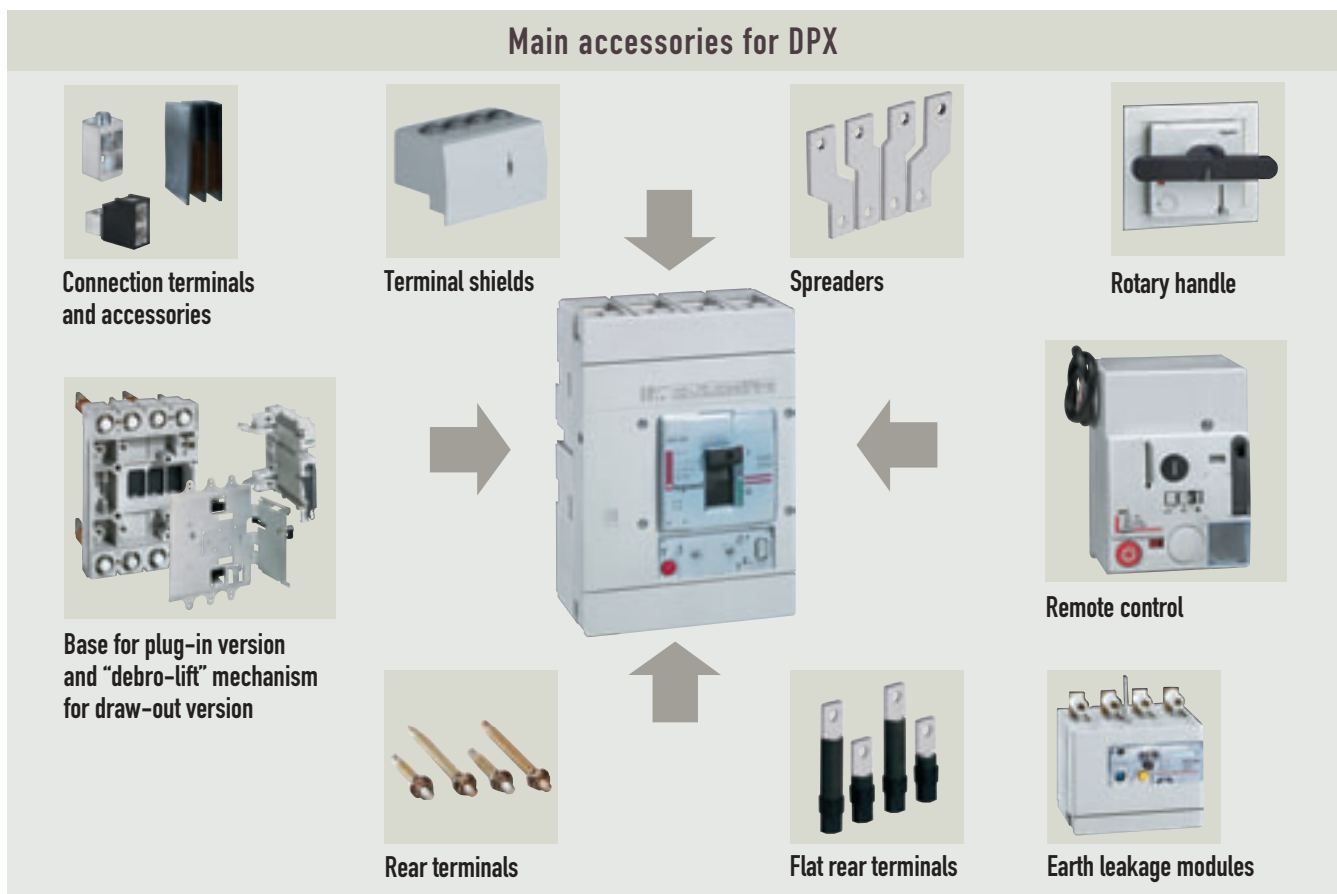

DPX mounting versions

Mounting		DPX 125			DPX 160			DPX 250 ER			DPX 250		DPX 630		DPX 1 600
		On its own	+ Side RCD	+ Downstr. RCD	On its own	+ Side RCD	+ Downstr. RCD	On its own	+ Side RCD	+ Downstr. RCD	On its own	+ Downstr. RCD	On its own	+ Downstr. RCD	On its own
On plate	Fixed	Front terminals	•	•	•	•	•	•	•	•	•	•	•	•	•
		Rear terminals	•		•	•		•		•	•	•	•	•	•
	Plug-in	Front terminals	•			•		•		•	•	•	•		•
		Rear terminals	•			•		•		•	•	•	•		•
	Draw-out	Front terminals									•	•	•	•	•
		Rear terminals									•	•	•	•	•

1 PLUG-IN AND DRAW-OUT VERSIONS

With the advantage of both plug-in and draw-out versions, DPXs - notwithstanding their ability to “make safe” installations and devices - represent a significant development in the actual functions of this type of device.

1.1. Plug-in versions

Plug-in (or disconnectable) devices can be inserted or removed without powering down the relevant circuit. Connection and disconnection are only possible when the device is open; otherwise, disconnection causes mechanical breaking of the device.

Plug-in devices can, in simple situations, be used for isolation and making safe, but they are primarily used for their interchangeability, which makes maintenance much easier.

They are sometimes designated by the letter D as “Disconnectable parts”.



< DPX 250
plug-in version,
mounted on its base
with rear terminals

Composition of plug-in and draw-out versions

Plug-in version

Base + DPX + tulip contacts

Draw-out version

Base + “Debro-lift” mechanism + DPX + tulip contacts

DPX moulded case circuit breakers (suite)

1.2. Draw-out versions

Draw-out devices, in addition to the advantages of plug-in devices (interchangeability and visible break isolation), can be used, due to the associated “debro-lift” mechanism, to control connection and disconnection, to enable tests and measurements on the auxiliary circuits while isolating the main circuits, to display the status of these circuits, and finally by means of different systems (padlocks, locks, etc) to lock the device for padlocking operations. Draw-out devices can be designated by the letter W as “Withdrawable parts”.



< DPX 1600 draw-out

“Debro-lift” mechanism

Very simple to install (two screws), the “debro-lift” mechanism is fixed on the support bases common to the devices.

The connection/disconnection operation is then performed mechanically by a crank mechanism.

The mechanism determines three positions identified by different coloured indicators:

- “connected”, main circuits and auxiliary circuits connected, red indicator
- “test”, main circuits isolated and auxiliary circuits connected, yellow indicator
- “drawn-out”, main circuits and auxiliary circuits isolated, green indicator

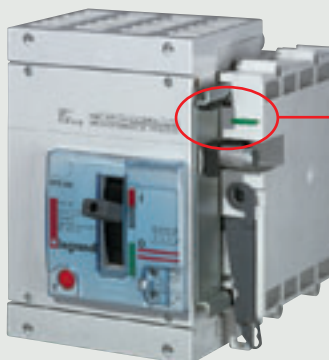

Indicator signalling the different positions of the mechanism

2 ELECTRICAL ACCESSORIES

2.1. Current shunt trip

Used to open the device remotely. It is always connected in series with an NO control type contact.

2.2. Undervoltage release

With or without a time delay, this causes the device to open during a significant reduction in or absence of control voltage. Undervoltage releases can be equipped with a time-lag module to avoid false tripping of the device when the release power supply voltage is not stable.

The releases are mounted to the left of the control switch handle under the device cover.

Characteristics of releases

Type of release	Current shunt trip	Undervoltage release
Operating voltage (% Un)	70 to 110	35 to 70
Recovery voltage (% Un)	-	85 to 110
Operating time	< 50 ms	< 50 ms
Inrush power consumption		
AC (VA)	300	5
DC (W)	300	1.6

the “tripped” position following operation of the protection unit, an auxiliary release, the residual current device, or following unplugging. The same product (Cat. No. 261 60) can be used to perform either the auxiliary contact or fault contact function, depending on where it is mounted in the DPX.

These contacts are mounted on the right of the control switch handle under the device’s cover.

2.3. Auxiliary contacts and fault signal contacts

These are used for remote feedback of information on the state of the circuit breaker. Auxiliary contacts (AC) indicate whether the device is open or closed, whereas fault signal contacts (FS) indicate that the device is in

Characteristics of auxiliary or fault signal contacts

Nominal voltage	AC (V~)	24 to 230
	DC (V=)	24 to 230
Permissible current (A)	110 V AC	4
	230 V AC	3
	24 V DC	5
	48 V DC	1.7

Mounting auxiliaries on DPX

Electrical auxiliaries are mounted on the front panel of the device, in reserved insulated compartments, with no action necessary on the internal mechanism. The cables exit via the side or rear opening on the device.

For plug-in and draw-out versions, the auxiliaries are connected on special connectors.

Maximum number of auxiliaries per DPX

	AC	FS	trip
DPX 125, 160, 250 ER	1	1	1
DPX 250	2	1	1
DPX 630	2	2	1
DPX 1600	3	1	1

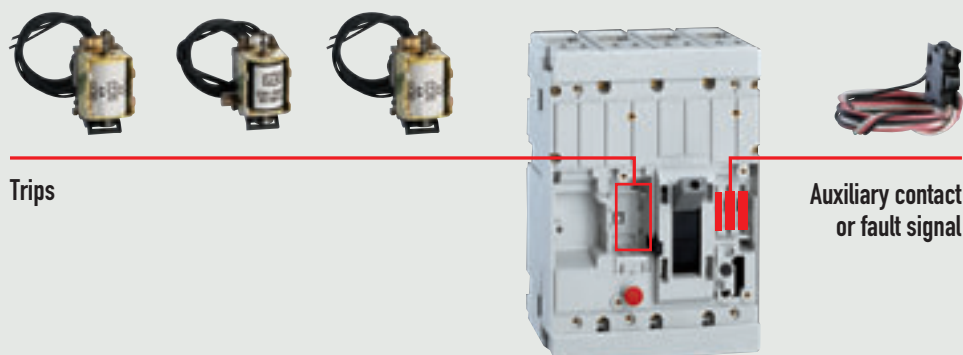

DPX moulded case circuit breakers (suite)

2.4. Motor-driven controls

These are used to control the opening and closing of circuit breakers remotely. They are mounted on the front panel of DPX. They can be fitted with locking devices.

Adding a motor-driven control makes no difference whatsoever to the mounting or connection options or auxiliaries for the devices.

Characteristics of motor-driven controls					
Device					
Power supply		24 V DC 230 V AC	24, 48 V DC 230 V AC	24, 48 V DC 230 V AC	24, 48 V DC 230 V AC
Opening + reset time		-	2 s	2 s	10 to 13 s
Opening time		< 90 ms	< 50 ms	< 50 ms	< 50 ms
Closing time		< 100 ms	< 100 ms	< 100 ms	< 100 ms
Power consumption	24 V DC	250 W	200 W	300 W	110 W
	230 V AC	250 VA	200 VA	300 VA	500 VA
Number of operations		8000	10 000	10 000	5000

3 SUPPLY INVERTORS

Supply invertors can be created with DPX 160, DPX 250, DPX 630 and DPX 1600 devices, using breakers or switches in fixed or draw-out versions, available in 3 different versions:

- **Manual:** the mounting plate, equipped with a mechanical interlock device, prevents the simultaneous closing of the two devices it supports. A device can only close if the other device is open.
- **Remote control:** the devices are equipped with motor-driven control and their operation can therefore be controlled remotely.
- **Automatic:** an electronic control unit (230 V AC or 24 V DC) drives the inverter.



< Control unit
Cat. No. 261 93, for controlling
supply invertors



< DPX 250 mounted as supply
invertors with motor-driven
controls

















4 CONNECTION OF DPX

Numerous accessories are available to meet all the various connection requirements. In addition to direct connection on a plate, they include terminals, distribution terminals, connection extensions, spreaders, rear screw terminals or rear flat terminals, etc.







All DPX can be supplied by either the upper or lower terminals without any derating of their performance.

Available connection accessories according to device and version

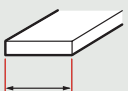

Version	Connection		DPX 125	DPX 160	DPX 250 ER	DPX 250	DPX 630	DPX 1600	
Fixed	Front terminals	Plates 		Fitted	Fitted	Fitted	Fitted	Fitted	
		Cage terminals 	Fitted	●	●	●	●	●	
		High-capacity terminals 		●			●	●	
		Connection extension 		●			●	●	
		Spreaders 				●	●	●	●
		Distribution terminals 							
	Rear terminals	Threaded 	●	●	●	●	●		
		Flat 				●	●		
		Flat short 						●	
		Flat long 						●	
	Plug-in	Front terminals	Plates 	●	●	●	●	●	
		Rear terminals	Threaded 	●	●	●	●	●	
Flat 						●	●		
Draw-out	Front terminals	Plates 				●	●	●	
	Rear terminals	Threaded 				●	●		
		Flat 				●	●		
		Flat 						●	

DPX moulded case circuit breakers (suite)

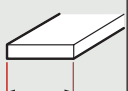

The following tables give the connection capacities for the various accessories selected.

Connection: maximum capacities for each pole								
Device	Connection method	 Busbars Width (mm)	 Conductors Cross-section (mm ²)		 Copper terminals		 Aluminium terminals	
			rigid	flexible	standard S - Ø (mm ² -mm)	compact S - Ø (mm ² -mm)	standard S - Ø (mm ² -mm)	compact S - Ø (mm ² -mm)
DPX 125 fixed version	Cage terminals (included with DPX)	12	70	70				
	Distribution terminals Cat. No. 048 67		6 x 35	6 x 25				
	Rear screw terminals Cat. Nos. 263 00/01	15						
DPX 125 plug-in version	Base with front terminals Cat. Nos. 263 02/04							
	Base with rear terminals Cat. Nos. 263 03/05	15						
DPX 160 fixed version	Direct on plate	18			50-6			50-8
	Cage terminals Cat. No. 262 18	13	95	70				
	Connection extensions Cat. No. 262 17	20			70-10			185-10
	High-capacity terminals Cat. No. 262 19		120	95				
	Distribution terminals Cat. No. 048 67		6 x 35	6 x 25				
	Rear screw terminals Cat. Nos. 263 10/11	25			120-8	185-10		120-10
DPX 160 plug-in version	Base with front terminals Cat. Nos. 263 12/14/16							
	Base with rear terminals Cat. Nos. 263 13/15/17	25			120-8	185-10		120-10

Connection: maximum capacities for each pole

Device	Connection method	 Busbars Width (mm)	Conductors		Copper terminals		Aluminium terminals	
			 Cross-section (mm ²)		standard	compact	standard	compact
			rigid	flexible	S - Ø (mm ² -mm)	S - Ø (mm ² -mm)	S - Ø (mm ² -mm)	S - Ø (mm ² -mm)
DPX 250 ER fixed version	Direct on plate	20			70-8			
	Cage terminals Cat. No. 262 88	18	185	150				
	Spreader Cat. Nos. 262 90/91	32			185-12	300-10	240-12	300-10
	Distribution terminals Cat. No. 048 68			4 x 35 + 2 x 25				
	Rear screw terminals Cat. Nos. 265 10/11				185-12		240-12	
DPX 250 ER plug-in version	Base with front terminals Cat. Nos. 265 14/15/20				95-8	185-10	95-12	185-10
	Base with rear terminals Cat. Nos. 265 16/17/21				185-12		240-12	
DPX 250 fixed version	Direct on plate	25			95-8	185-10		185-10
	Cage terminals Cat. No. 262 35	18	185	150				
	Connection extensions Cat. No. 262 32	25			150-12	300-10	240-12	300-10
	Spreaders Cat. Nos. 262 33/34	32			185-12	300-10	240-12	300-10
	Distribution terminals Cat. No. 048 68			4 x 35 + 2 x 25				
	Rear screw terminals Cat. Nos. 263 31/32	25			185-12		240-12	
	Flat rear terminals Cat. Nos. 265 27/28	25			95-10	185-10	150-12	185-10
DPX 250 plug-in or draw-out version	Base with front terminals Cat. Nos. 265 31/32/37	20						
	Base with rear screw terminals Cat. Nos. 265 33/34/38	25			185-12		240-12	
	Base with flat rear terminals Cat. Nos. 265 35/36/39	25			95-10	185-10	150-12	185-10
	XL-Part 1600 base Cat. Nos. 098 25/26/27/28	20			2 x 95-8	2 x 195-10		2 x 185-10

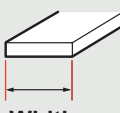
DPX moulded case circuit breakers (suite)

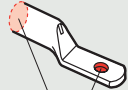
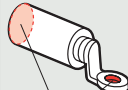
Connection: maximum capacities for each pole								
Device	Connection method	 Busbars Width (mm)	 Conductors Cross-section (mm ²)		Copper terminals standard compact  S - Ø (mm ² -mm)		Aluminium terminals standard compact  S - Ø (mm ² -mm)	
			rigide	soUPLE				
DPX 630 fixed version	Direct on plate	32			150-12	300-10	240-12	300-10
	Cage terminals Cat. Nos. 262 88	25	300	240				
	Terminals for 2 conductors Cat. No. 262 51		2 x 240	2 x 185				
	Connection extensions Cat. No. 262 47	32			2 x 150-12	2 x 300-10	2 x 240-12	2x 300-10
	Spreader Cat. Nos. 262 48/49	50			2 x 185-12	2 x 300-10	2 x 240-16	2x 300-10
	Rear screw terminals Cat. Nos. 263 50/51	32			2 x 300-16		2 x 300-16	
Flat rear terminals Cat. Nos. 263 52/53	40			2 x 185-12	2 x 300-10	2 x 240-12	2 x 300-10	
DPX 630 plug-in or draw-out version	Base with front terminals Cat. Nos. 265 52/53/58	25			150-12	300-10	240-12	300-10
	Base with rear terminals Cat. Nos. 265 54/55/59	32			2 x 300-16		2 x 300-16	
	Base with flat rear terminals Cat. Nos. 265 56/57/60	40			2 x 185-12	2 x 300-10	2 x 240-12	2 x 300-10
	XL-Part 1600 base Cat. Nos. 098/71/72/73/74	25			150-12	2 x 300-10	2 x 240-12	2 x 300-10
DPX 1600 fixed version	Direct on plate	50			300-14		300-16	
	Terminals for 2 conductors Cat. No. 262 69		2 x 240	2 x 185				
	Terminals for 4 conductors Cat. No. 262 70		4 x 240	4 x 158				
	Connection extensions Cat. Nos. 262 67/68	50			2 x 300-14		2 x 300-16	2 x 300-14
	Spreaders Cat. Nos. 262 73/74	80			4 x 300-14		2 x 300-16	2 x 300-14
	Short rear terminals Cat. Nos. 263 31/32	50			2 x 300-14		2 x 300-16	2 x 300-14
Long rear terminals Cat. Nos. 265 27/28	50			3 x 300-14		3 x 300-16	3 x 300-14	
DPX 1600 draw-out version	Base with front terminals Cat. Nos. 265 31/32/37	50			4 x 120-12 2 x 300-14	4 x 185-10	2 x 300-14	4 x 150-10
	Base with rear terminals Cat. Nos. 265 33/34/38	50			2 x 185-12		2 x 240-12	

ADAPTABLE ELECTRONIC EARTH LEAKAGE MODULES

All DPX circuit-breakers up to 630 A can be fitted with earth leakage modules without modifying their technical characteristics and with the same options for accessories.

There are two versions of the earth leakage module up to 250 ER with the same technical characteristics but a different method of mounting:

- mounted side by side
- mounted underneath

For DPX 250 and 630, the electronic module is always mounted underneath. For DPX 1600, a residual current relay with separate core is used. Residual current devices: see book 06 "Electrical hazards and protecting people".

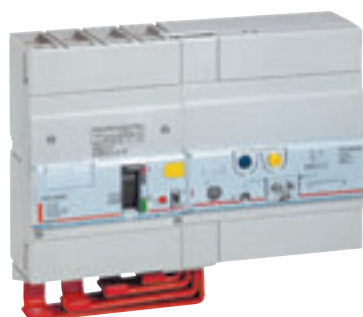

^ DPX 250 ER with side-mounted earth leakage module

Residual current relays with separate core



These add a residual current function to DPX and DMX-E circuit breakers and switches equipped with trip coils.

Characteristics of electronic earth leakage modules for DPX

Device	DPX 125		DPX 160		DPX 250 ER		DPX 250	DPX 630
	side	underneath	side	underneath	side	underneath	underneath	underneath
Mounting	side	underneath	side	underneath	side	underneath	underneath	underneath
Nominal current I_n (A)	125	125	160	160	160/250	160/250	250	400/630
Number of poles	3-4	4	3-4	4	4	4	4-3	4-3
Dimensions (mm)	Width	101	101	120	120	120	140	183
	Depth	74	74	74	74	74	105	105
	Height	120	90	150	115	150	108	152
Nominal voltage U_e V AC (50-60 Hz)	500	500	500	500	500	500	500	500
Operating voltage V AC (50-60 Hz)	230-500	230-500	230-500	230-500	230-500	230-500	230-500	230-500
Sensitivity $I_{\Delta n}$ (A)	0.03-0.3-1-3	0.03-0.3-1-3	0.03-0.3-1-3	0.03-0.3-1-3	0.03-0.3-1-3	0.03-0.3-1-3	0.03-0.3-1-3	0.03-0.3-1-3
Time delay Δt (s)	0- 0.3-1-3	0- 0.3-1-3	0- 0.3-1-3	0- 0.3-1-3	0- 0.3-1-3	0- 0.3-1-3	0- 0.3-1-3	0- 0.3-1-3
Detection of faults with DC components	•	•	•	•	•	•	•	•
Mounting on rail	•		•		•			
Versions	fixed, front terminals	•	•	•	•	•	•	•
	fixed, rear terminals		•		•		•	•
Connection terminals	Supplied with the DPX	•	•					
	On request			•	•	•	•	•

DPX moulded case circuit breakers (suite)

SPECIAL APPLICATIONS AND DERATING

1 USE IN AN IT SYSTEM

In an installation with an IT system, it is the breaking capacity on one pole which must be taken into account for the 2nd fault current.

Breaking capacity of a single pole at 400 V in accordance with EN 60947-2	
DPX 125	9 kA
DPX 160	9 kA
DPX 250 ER	9 kA
DPX 250	16 kA ⁽¹⁾
DPX - H 250	20 kA ⁽¹⁾
DPX 630	16 kA ⁽¹⁾
DPX - H 630	20 kA ⁽¹⁾
DPX 1600	20 kA ⁽¹⁾
DPX - H 1600	25 kA ⁽¹⁾

(1) Breaking capacity value on one pole, taken as being equal to the breaking capacity at 690 V 3-phase. (art. 533.3 NF C 15-100)

2 HIGH TEMPERATURES

A circuit breaker is set to operate at I_n at an ambient temperature of 40 °C for DPX circuit breakers (standard IEC 60947-2). When the ambient temperature inside the enclosure where the DPX units are installed is higher than this value, the rated tripping current should be reduced in order to avoid false tripping.

2.1. Fixed version

The minimum value of the rated current corresponds to the minimum setting of the I_r/I_n trip unit (0.7 for DPX 125 - 0.64 for DPX 160 - 0.8 for DPX 400 - 0.4 for DPX 630 - 0.4 for DPX 1600).

Derating for fixed version DPX (in A) depending on the thermal setting (I_r) according to the temperature in the enclosure									
Thermal magnetic MCCB	I_n (A)	40°C		50°C		60°C		70°C	
		min	max	min	max	min	max	min	max
DPX 125	16	11	16	10	15	10	14	9	13
	25	17	25	16	24	16	23	15	22
	40	28	40	27	38	26	37	25	36
	63	44	63	42	60	40	58	38	55
	100	70	100	67	96	64	92	61	88
	125	87	125	84	120	80	115	76	110
DPX 160	25	16	25	14	23	13	20	12	18
	40	25	40	23	36	20	32	18	28
	63	40	63	36	57	32	50	28	43
	100	63	100	58	91	52	82	48	73
	160	100	160	93	145	83	130	73	115
DPX 250 ER	100	64	100	58	91	52	82	47	73
	160	102	160	93	145	83	130	74	115
	250	160	250	147	230	134	210	122	190
DPX 250	100	63	100	58	91	52	82	48	73
	160	100	160	93	145	83	130	73	115
	250	160	250	147	230	130	210	115	190
DPX 630	320	250	320	230	288	205	256	180	225
	400	320	400	288	360	256	320	225	280
	500	400	500	380	480	360	450	340	420
	630	500	630	480	600	450	570	420	540
DPX 1600	800	630	800	600	760	570	720	540	680
	1000	800	1000	760	950	720	900	680	850
	1250	1000	1250	950	1190	900	1125	850	1080
	1600	1000	1600	950	1190	900	1125	850	1080
Electronic MCCB	I_n (A)	40°C		50°C		60°C			
DPX 250	250	250	250	250	250	250	250	250	238
	630	630	630	630	630	630	630	630	567
DPX 1600	800	800	800	800	800	800	800	800	760
	1250	1250	1250	1250	1250	1250	1250	1250	1125
	1600	1600	1600	1600	1600	1600	1600	1600	1440

2.2. Plug-in and draw-out versions:

Apply a reduction coefficient of 0.85 to the maximum found value of the rated current.

2.3. Version with earth leakage module:

Apply a reduction coefficient of 0.9 to the maximum found value of the rated current.

Apply a coefficient of 0.7 if the two versions are simultaneous.

3 DC POWER SUPPLY

Thermal-magnetic DPX can also be used up to an operating voltage of 250 V DC (three poles in series). Their magnetic thresholds are then increased by 50% (see table below). For voltages greater than 250 V DC, please contact us.

Breaking capacities and protection thresholds of DPX with DC supply						
Appareil	Breaking capacity I _{cu} (kA) 2 poles in serie	Protection thresholds				
		In (A)	110-125 V DC	250 V DC	thermal % I _r	magnetic % I _m
DPX 125	16 kA	25-125	20	16	100 %	150 %
	25 kA	25-125	30	25	100 %	150 %
	36 kA	16-125	36	30	100 %	150 %
DPX 160	25 kA	63-160	30	25	100 %	150 %
	50 kA	25-160	50	36	100 %	150 %
DPX 250 ER	25 kA	100-250	30	25	100 %	150 %
	50 kA	160-250	50	36	100 %	150 %
DPX 250	36 kA	63-250	40	36	100 %	150 %
DPX-H 250	70 kA	40-250	45	40	100 %	150 %
DPX 630	36 kA	320-630	40	36	100 %	150 %
DPX-H 630	70 kA	320-630	45	40	100 %	150 %

4 400 Hz POWER SUPPLY

The stated characteristics for the devices assume a frequency of 50/60 Hz. They should be corrected for use at 400 Hz.

For DPXs, the correction factors given in the table opposite are to be applied when adjusting the thermal and the magnetic settings.

Correction factors to be applied when setting thermal-magnetic trip DPXs. for use at 400 Hz					
Device type	In (A)	Thermal setting		Réglage du magnétique	
		Correction factor	I _r max at 400 Hz	Correction factor	I _m at 400 Hz
DPX 125	16	1	16	2	1000
	25	1	25	2	1250
	40	1	40	2	1800
	63	0.95	60	2	1900
	100	0.9	90	2	2500
DPX 160	125	0.9	112	2	2500
	16	1	25	2	800
	40	1	40	2	800
	63	0.95	60	2	1250
	100	0.95	95	2	2000
DPX 250 ER	160	0.9	145	2	3200
	100	0.95	95	2	2000
	250	0.85	210	2	5000
DPX 250	40	1	40	2	280 to 800
	63	0.95	60	2	440 to 1250
	100	0.95	95	2	700 to 2000
	160	0.9	145	2	1120 to 3200
DPX 630	250	0.85	210	2	1800 to 5000
	400	0.8	320	1	2000 to 4000
DPX 1600	630	0.6	380	1	3200 to 6300
	800	0.6	480	1	4000 to 8000
	1250	0.6	750	1	3800 to 7500

DPX moulded case circuit breakers (suite)

PERFORMANCE DATA

1 THERMAL-MAGNETIC DPX

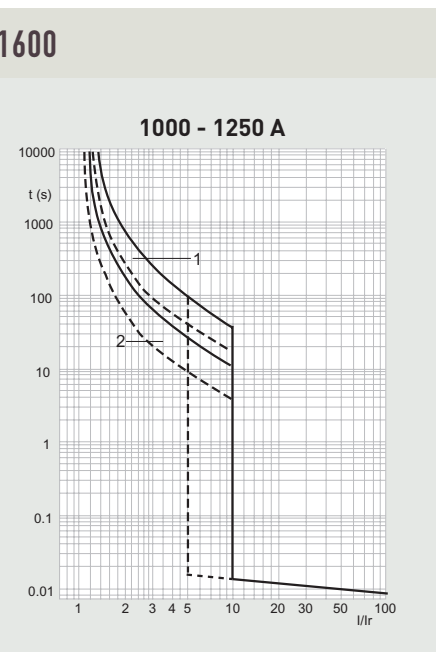
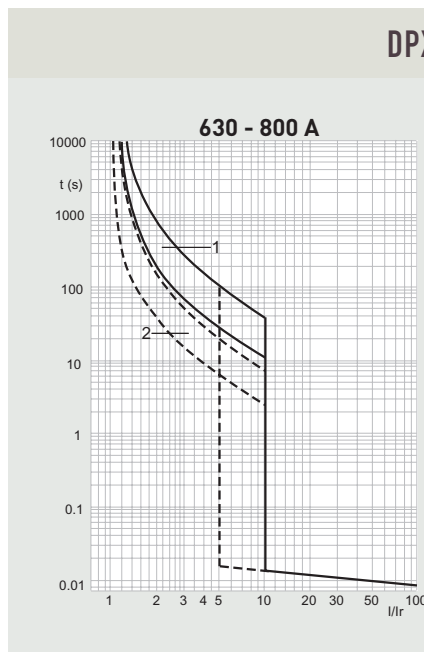
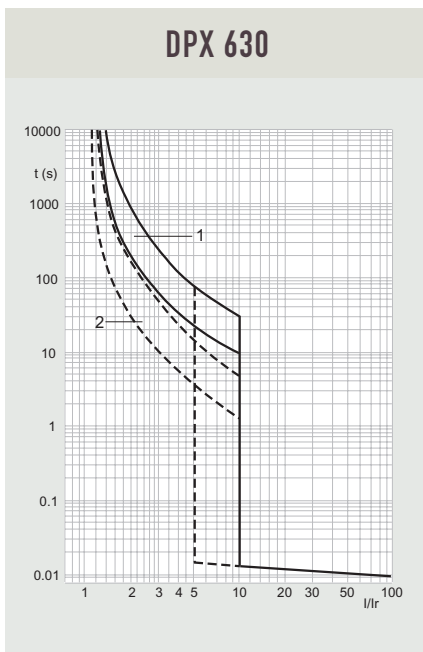
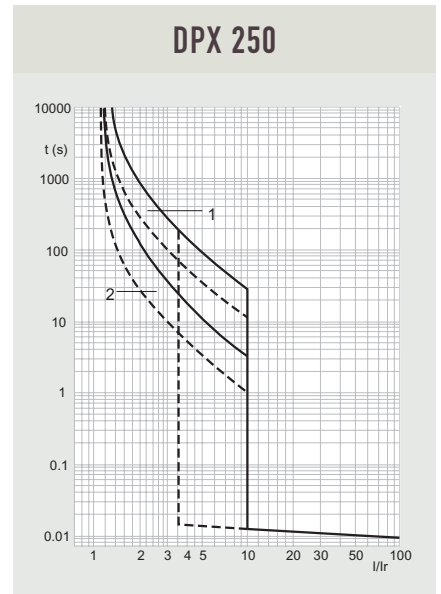
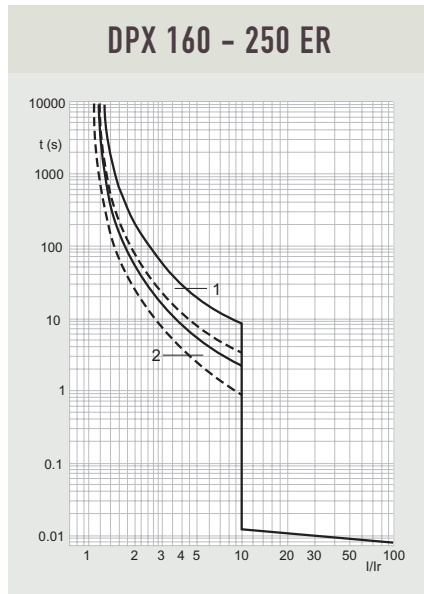
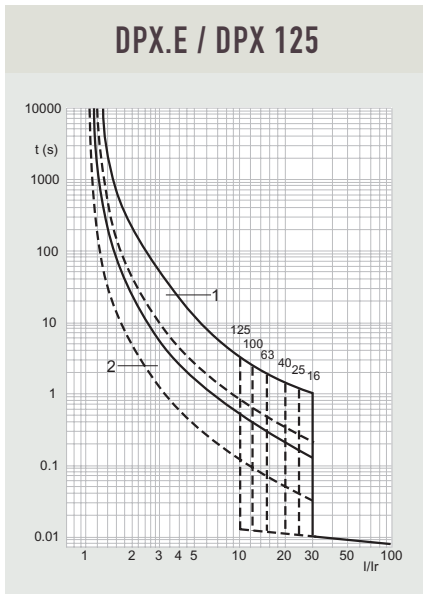

1: thermal tripping zone when cold - 2: thermal tripping zone when hot

2 ELECTRONIC DPX

DPX 250 - 630 - 1600 S1 electronic

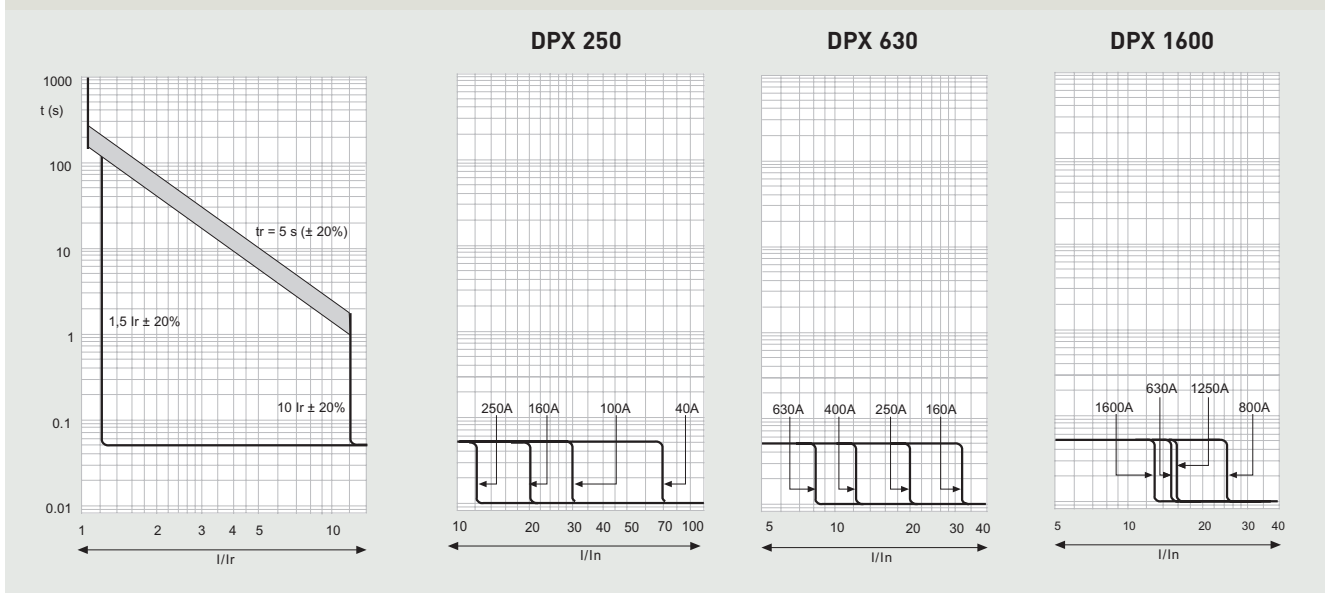

DPX 630 - 1600 S2 electronic

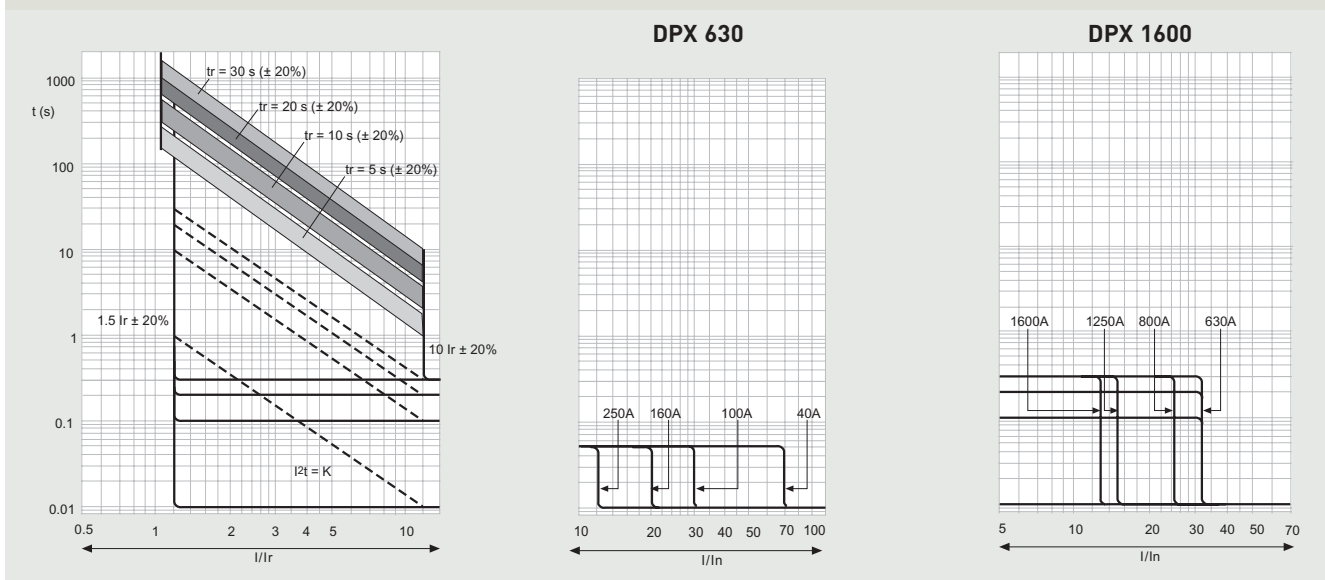

DPX moulded case circuit breakers (suite)

LIMITATION CURVES

1 THERMAL STRESS LIMITATION

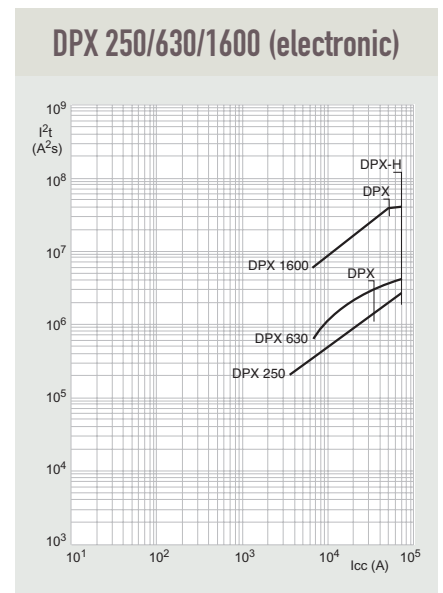
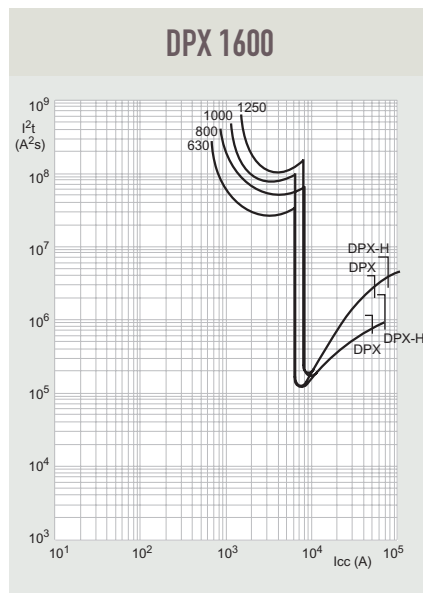
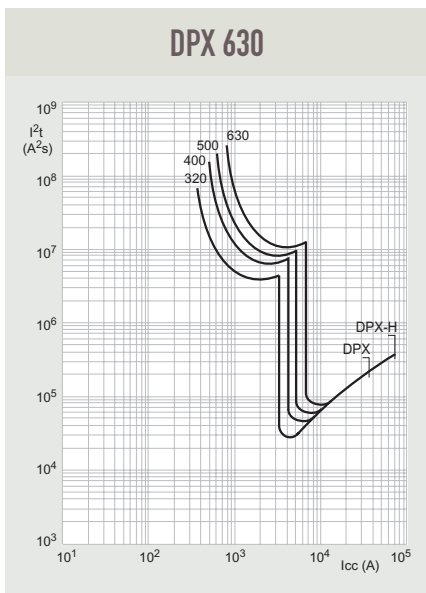
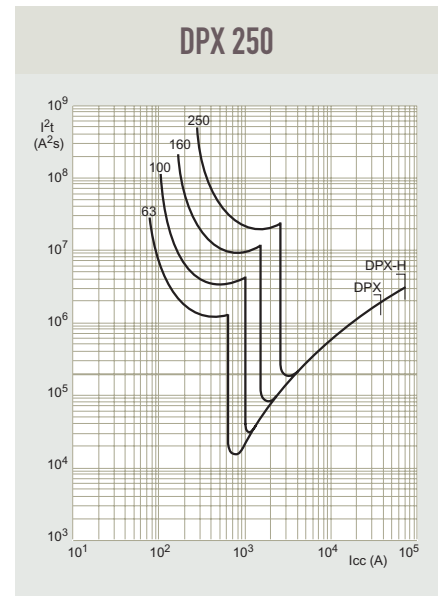
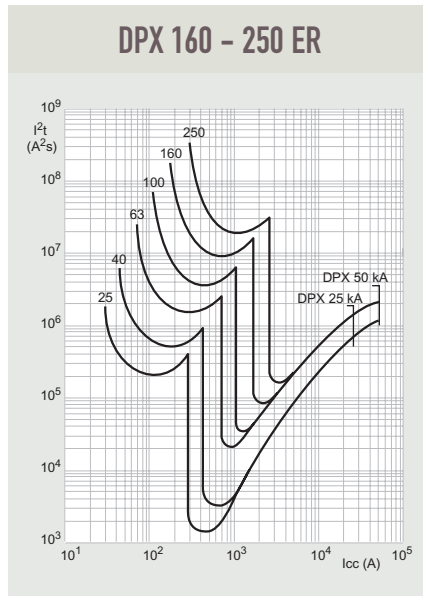
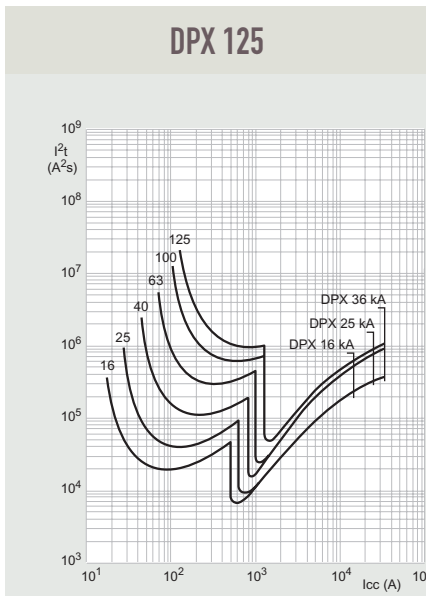

2 CURRENT LIMITATION

DPX 125

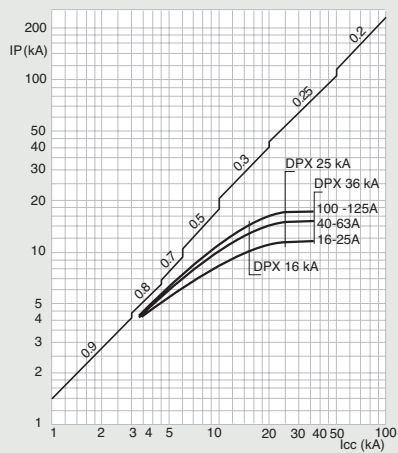

DPX 160 - 250 ER

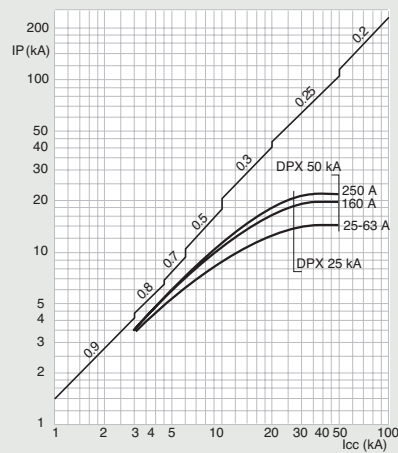

DPX 250

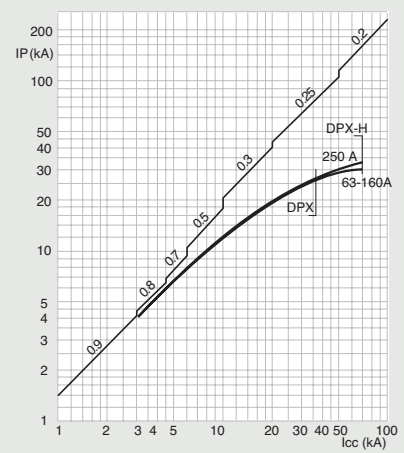

DPX 630

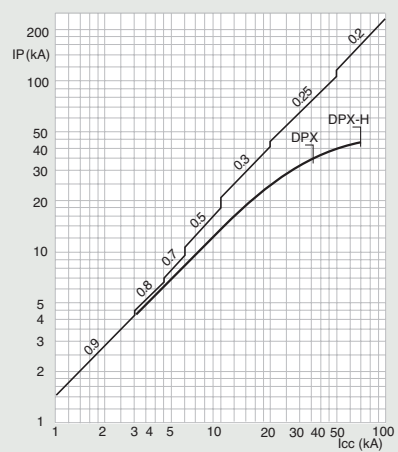

DPX 1600

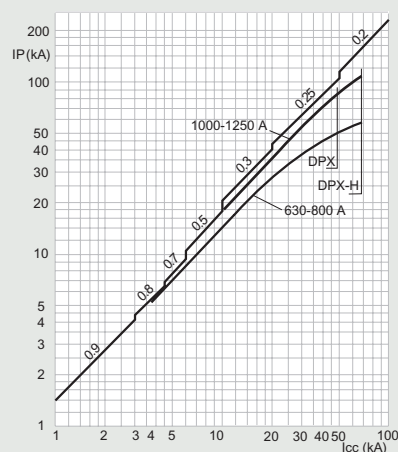

DPX moulded case circuit breakers (continued)

DIMENSIONS

1 DPX 125

■ Fixed version, front terminals

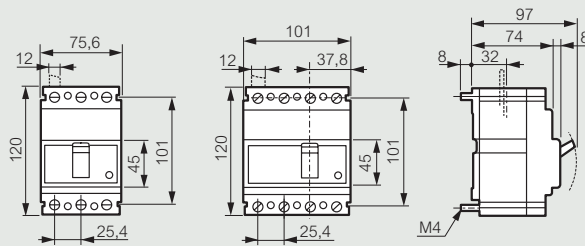

■ Fixed version, front terminals with earth leakage module mounted side by side

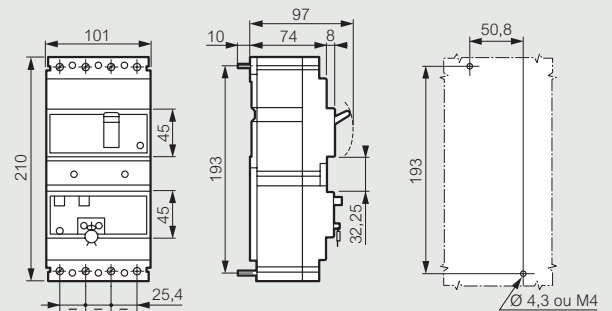

■ Fixed version, rear terminals

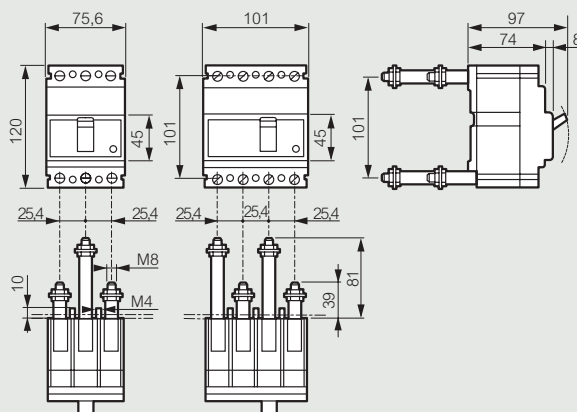

■ Fixed version, rear terminals with earth leakage module mounted side by side

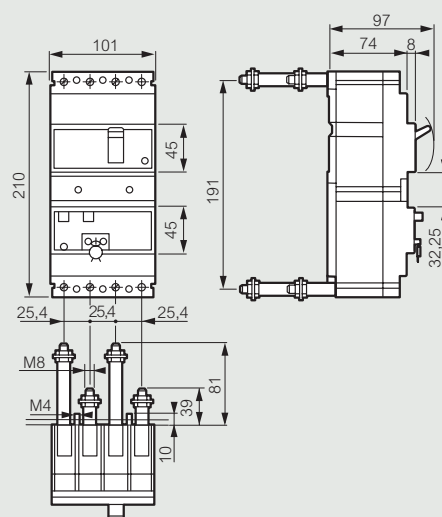

Terminal shields

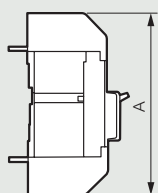

	A
DPX 125	170
DPX 125 + earth leakage module mounted side by side	260

Fixed version, front terminals with earth leakage module mounted underneath⁽¹⁾

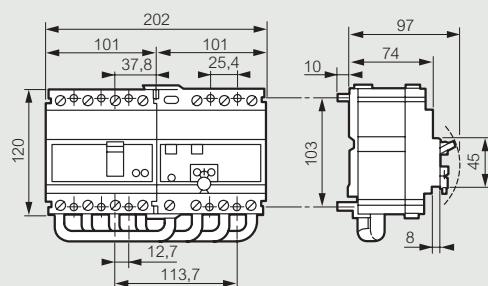

(1) Dimensions of 3-pole earth leakage modules are the same as 4-pole earth leakage modules

Direct rotary handle on DPX

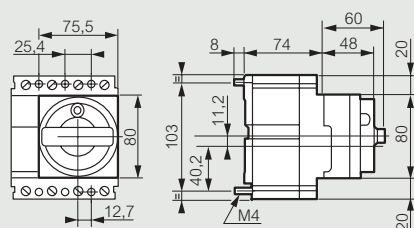

Vari-depth handle on door

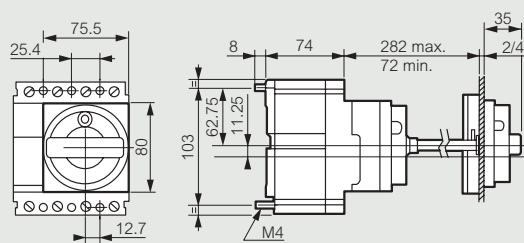

DPX moulded case circuit breakers (continued)

2 DPX 160

■ Fixed version, front terminals

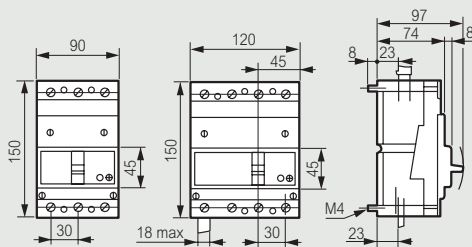

■ Fixed version, front terminals with earth leakage module mounted side by side

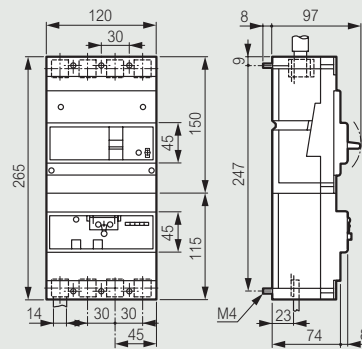

■ Fixed version, rear terminals

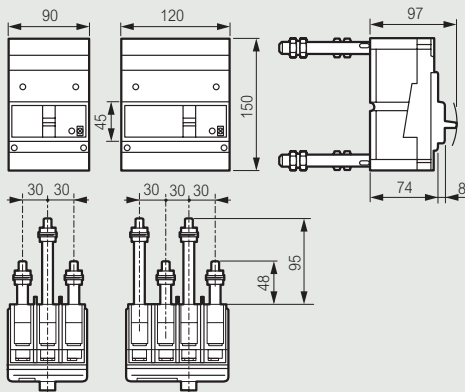

■ Fixed version, rear terminals with earth leakage module mounted side by side

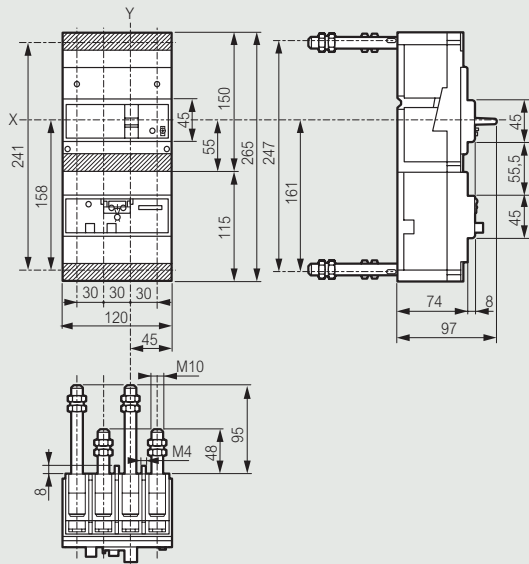

■ Fixed version, front terminals with earth leakage module mounted underneath⁽¹⁾

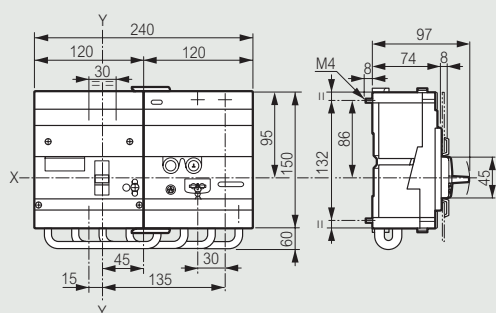

■ Terminal shields

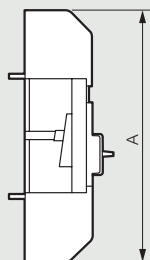

	A
DPX 160	278
DPX 160 + earth leakage module mounted side by side	393

(1) Dimensions of 3-pole earth leakage modules are the same as 4-pole earth leakage modules

■ Direct rotary handle on DPX

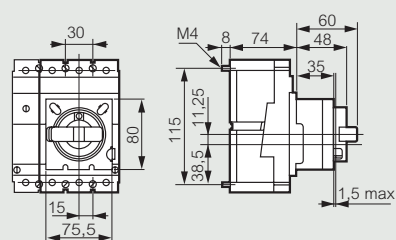

■ Vari-depth handle on door

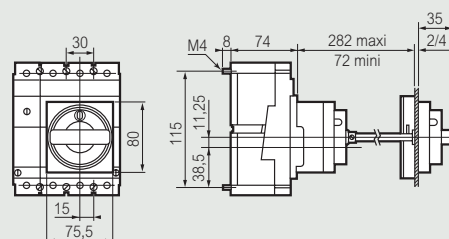

DPX moulded case circuit breakers (continued)

3 DPX 250 ER

■ Fixed version, front terminals

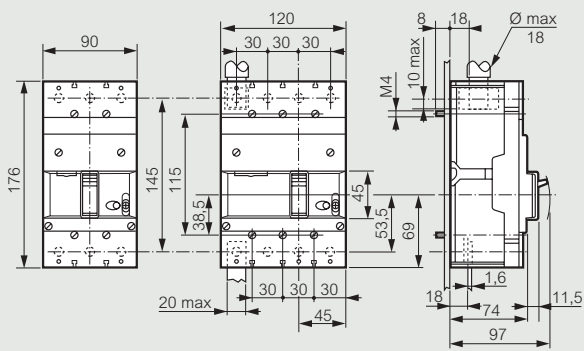

■ Fixed version, front terminals with earth leakage module mounted underneath

160 A

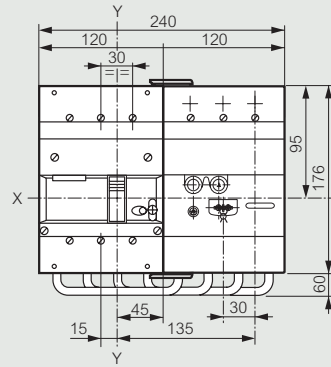

250 A

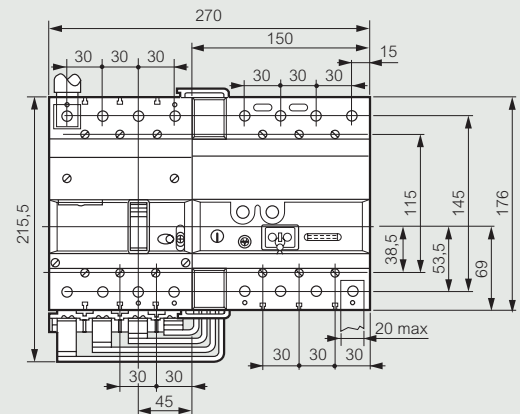

■ Fixed version with earth leakage module mounted side by side

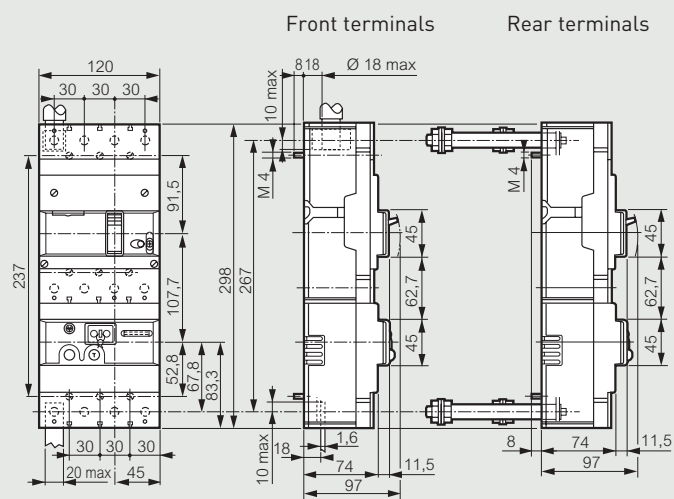

■ Direct rotary handle on DPX and vari-depth handle on door

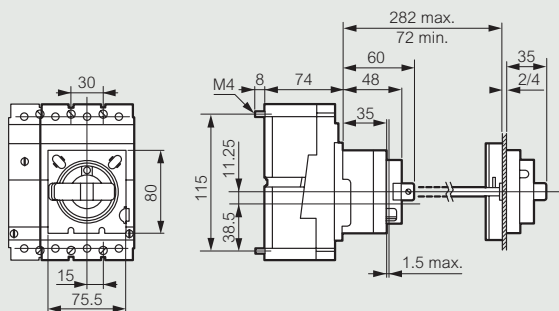

■ Terminal shields

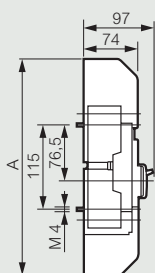

	A
DPX 250 ER	296
DPX 250 ER + earth leakage module	418

DPX moulded case circuit breakers (continued)

4 DPX 250

■ Fixed version, front terminals

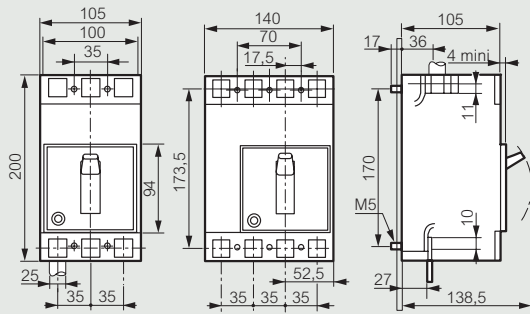

■ Plug-in version, front terminals

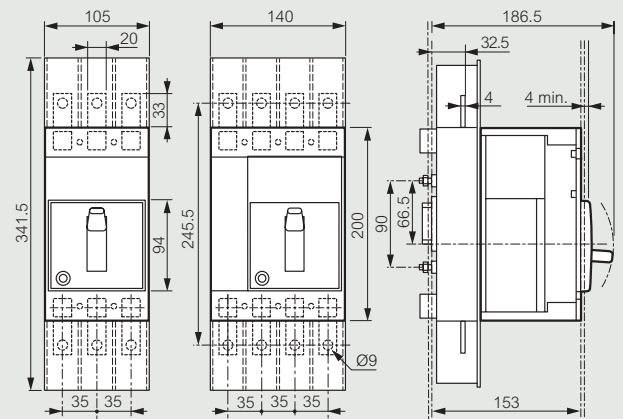

■ Fixed version with earth leakage module mounted side by side⁽¹⁾

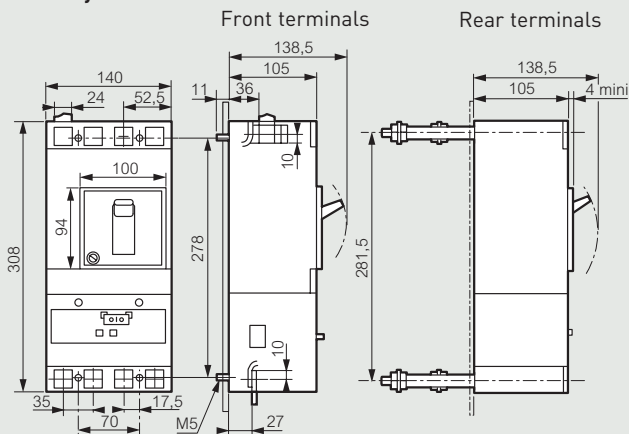

■ Plug-in version, rear terminals

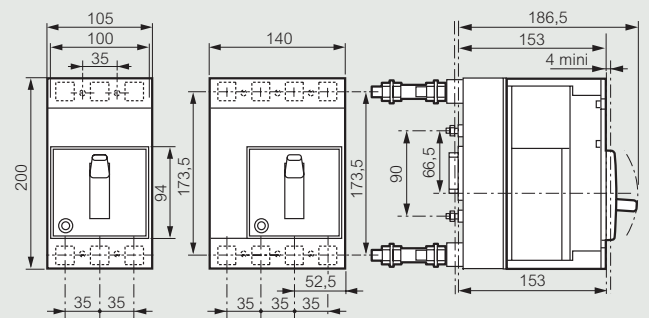

■ Draw-out version, front terminals

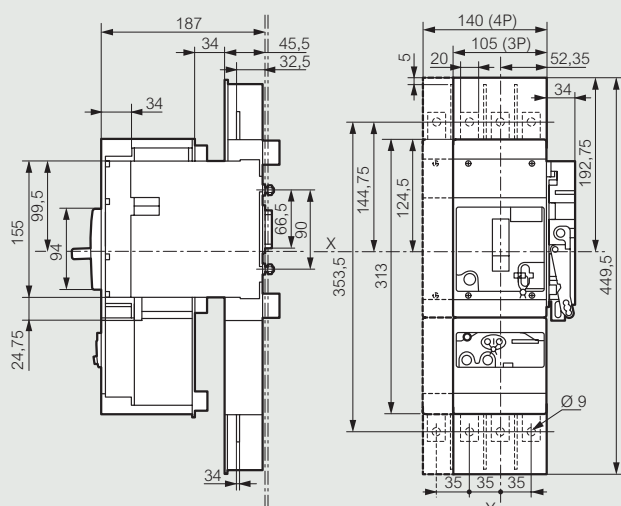

■ Terminal shields

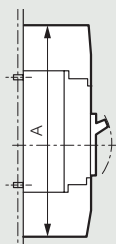

	A
DPX 250	330
DPX 250 + earth leakage module mounted side by side	438

■ Draw-out version, rear terminals

Rear terminal with threaded rod

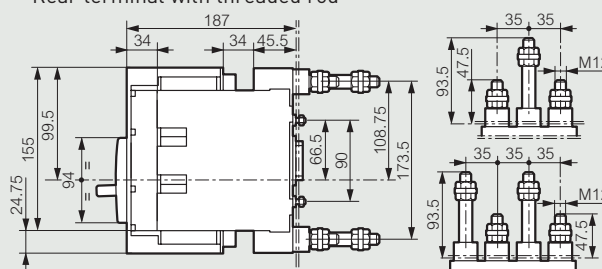

Flat rear terminals

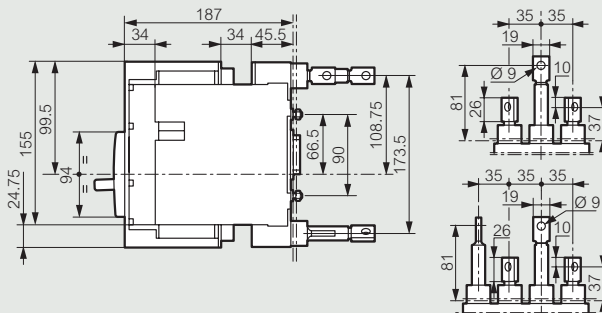

■ Direct rotary handle on DPX and vari-depth handle on door

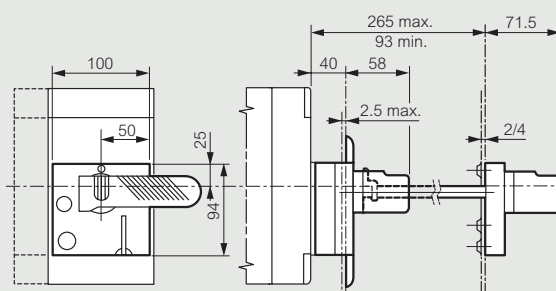

DPX moulded case circuit breakers (continued)

5 DPX 630

■ Fixed version, front terminals

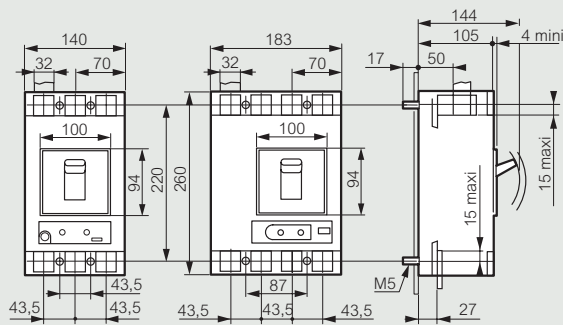

■ Plug-in version, front terminals

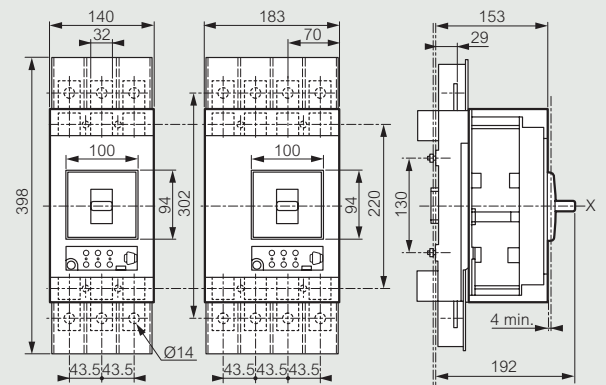

■ Fixed version with earth leakage module mounted side by side

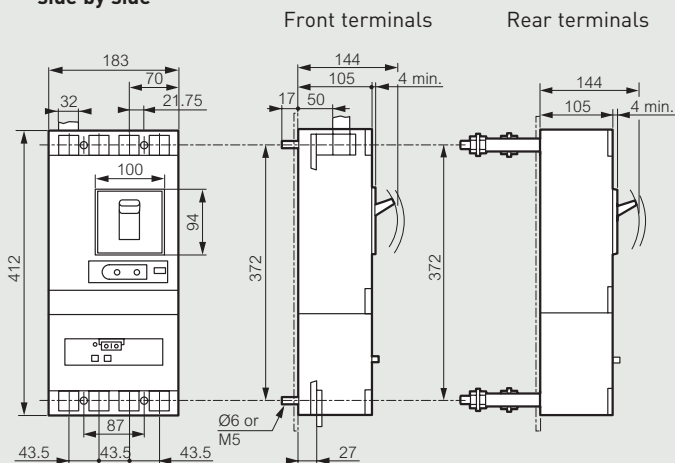

■ Plug-in version, rear terminals

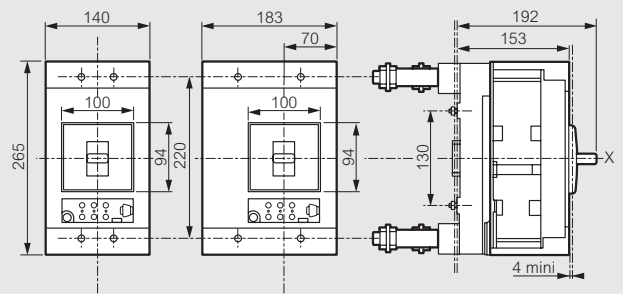

■ Draw-out version, front terminals

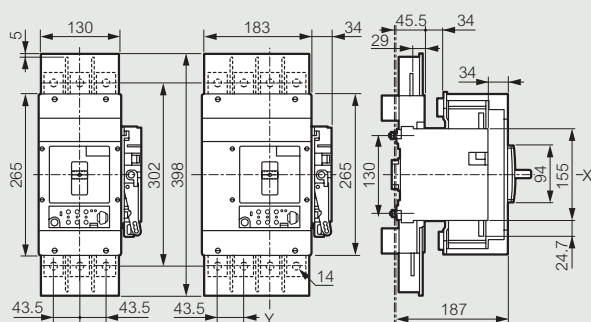

■ Draw-out version, rear terminals

Rear terminal with threaded rod

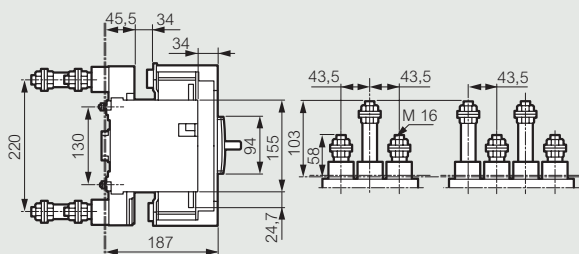

Flat rear terminal

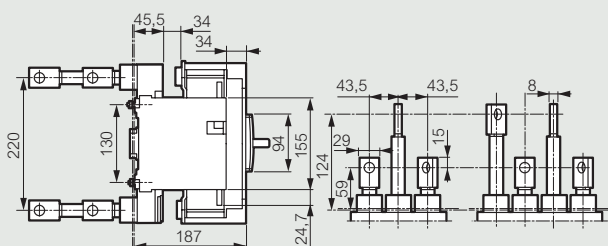

■ Terminal shields

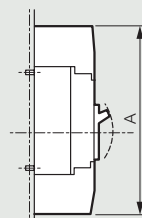

	A
DPX 630	390
DPX 630 + earth leakage module mounted side by side	542

■ Direct rotary handle on DPX and vari-depth handle on door

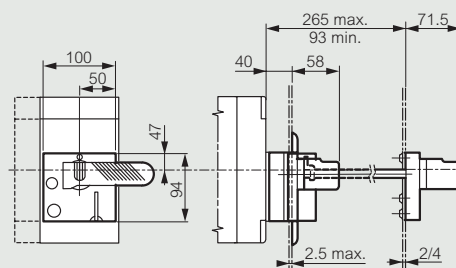

DPX moulded case circuit breakers (continued)

6 DPX 1600

■ Fixed version, front terminals

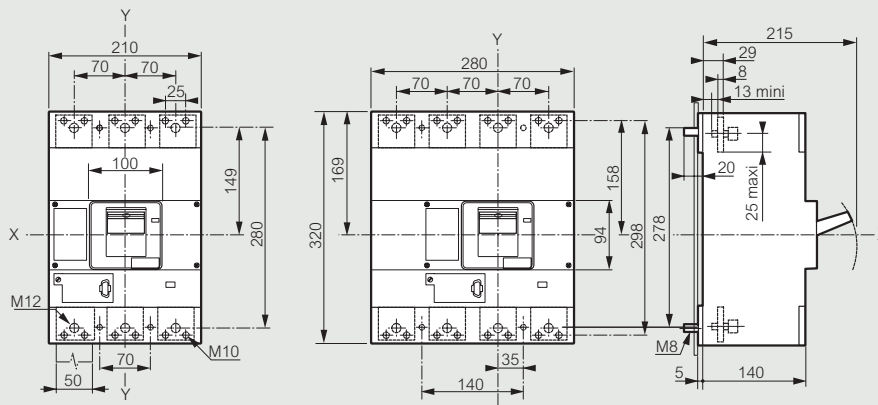

■ Fixed version, rear terminals

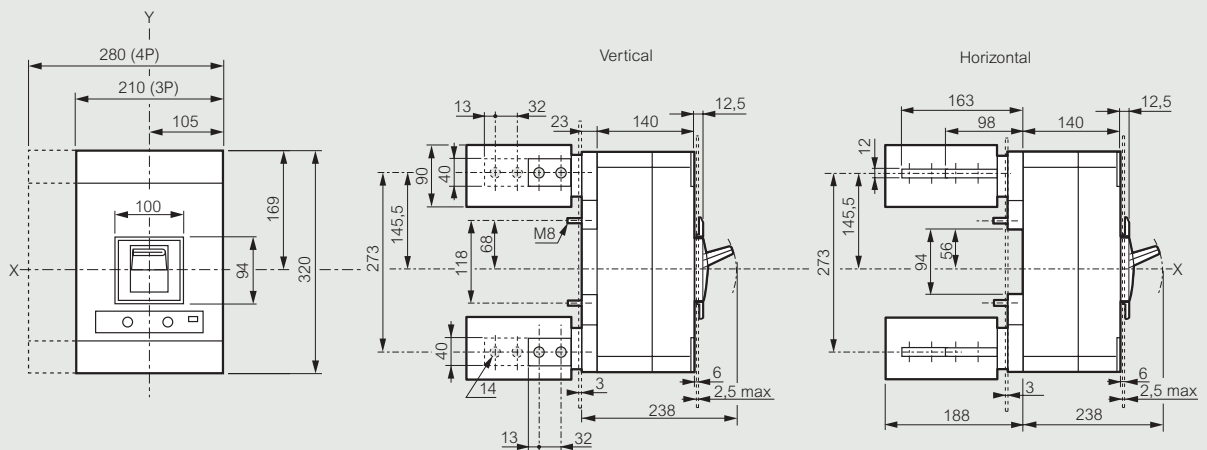

■ Draw-out version, rear terminals

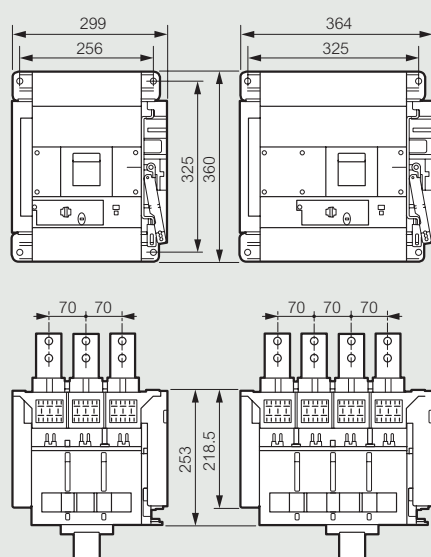

Terminal shields

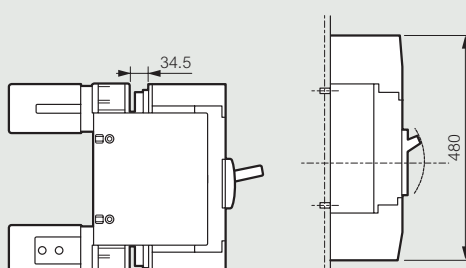

■ Direct rotary handle on DPX

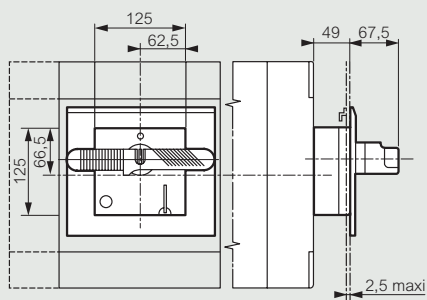

■ Vari-depth handle on door

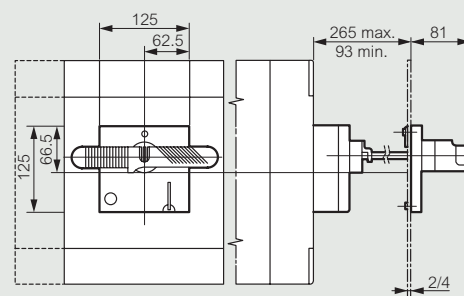

DPX moulded case circuit breakers (continued)

7 MINIMUM MOUNTING DISTANCES

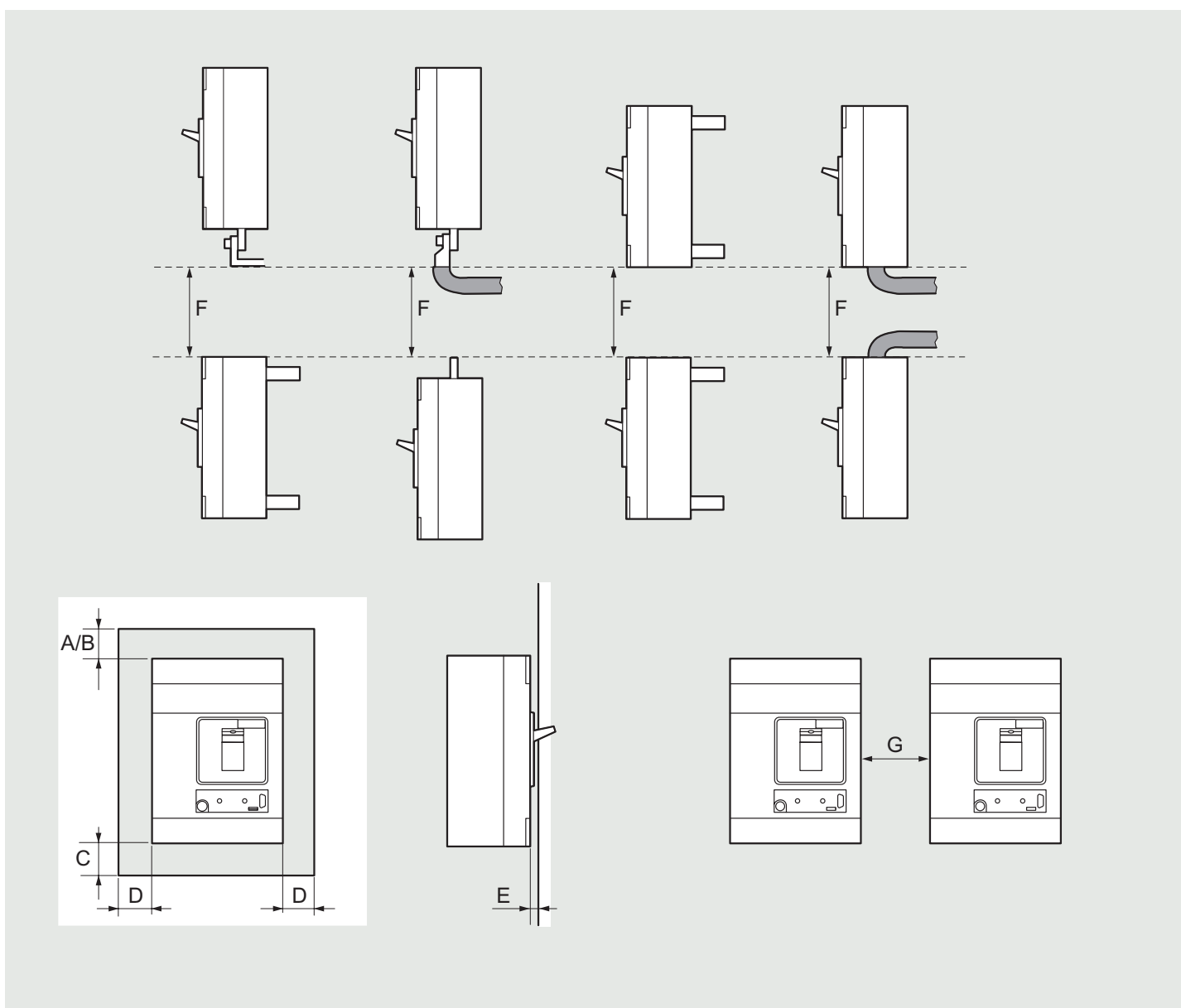

Minimum distances

MCCB	Nominal rating	mass wall	insulating wall	mass wall	metal side	panel door	distance between two MCCBs	
	In (A)	A (mm)	B (mm)	C (mm)	D (mm)	E (mm)	F (mm)	G (mm)
DPX 125	16 to 125	60	30	20	20	0	80	0
DPX 160	63 to 160	60	30	20	20	0	100	0
DPX 250 ER	100 to 250	60	30	20	20	0	100	0
DPX 250	40 to 250	70	25	25	25	0	140	0
DPX 630	250 to 630	70	25	25	25	0	160	0
DPX 1600	800 to 1600	90	40	40	40	0	160	0

DRX moulded case circuit breakers

DRX “moulded case” devices provide an intermediate solution between the DPX and the LR, DX-E and DX range of modular circuit breakers, which makes it a universal circuit breaker.

THE DRX RANGE

DRX 100



1P, 2P, 3P and 4P from 15 A up to 100 A

DRX 250

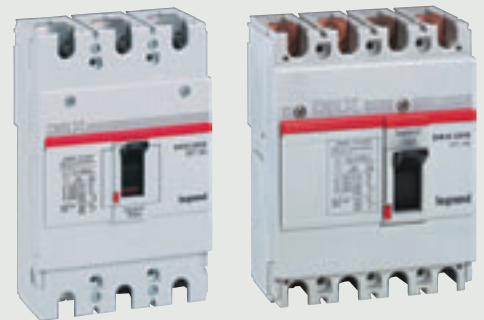

3P and 4P from 125 A up to 250 A

The simplicity of the DRX range makes these circuit breakers the natural choice for the least complex installations where there is no requirement for adaptability.

DRX circuit breakers can be mounted on a DIN rail using an adaptor plate.

They have an integrated thermal-magnetic release whose operating values (thermal and magnetic) are factory set and cannot be changed.

These protection devices are for use in installations that do not require discrimination or combination of devices, or any additional protection (such as earth leakage module).

They are certified as conforming to IEC 60947-1-2-3 and CCC standards, and are Nema, JIS and KS approved.



DRX circuit breaker: safety and simplicity

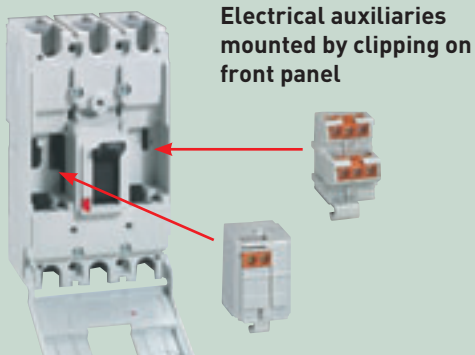

Electrical auxiliaries mounted by clipping on front panel



Exclusive system: with a single action, change from the 50 mm standard to the 45 mm DIN standard

Accessories

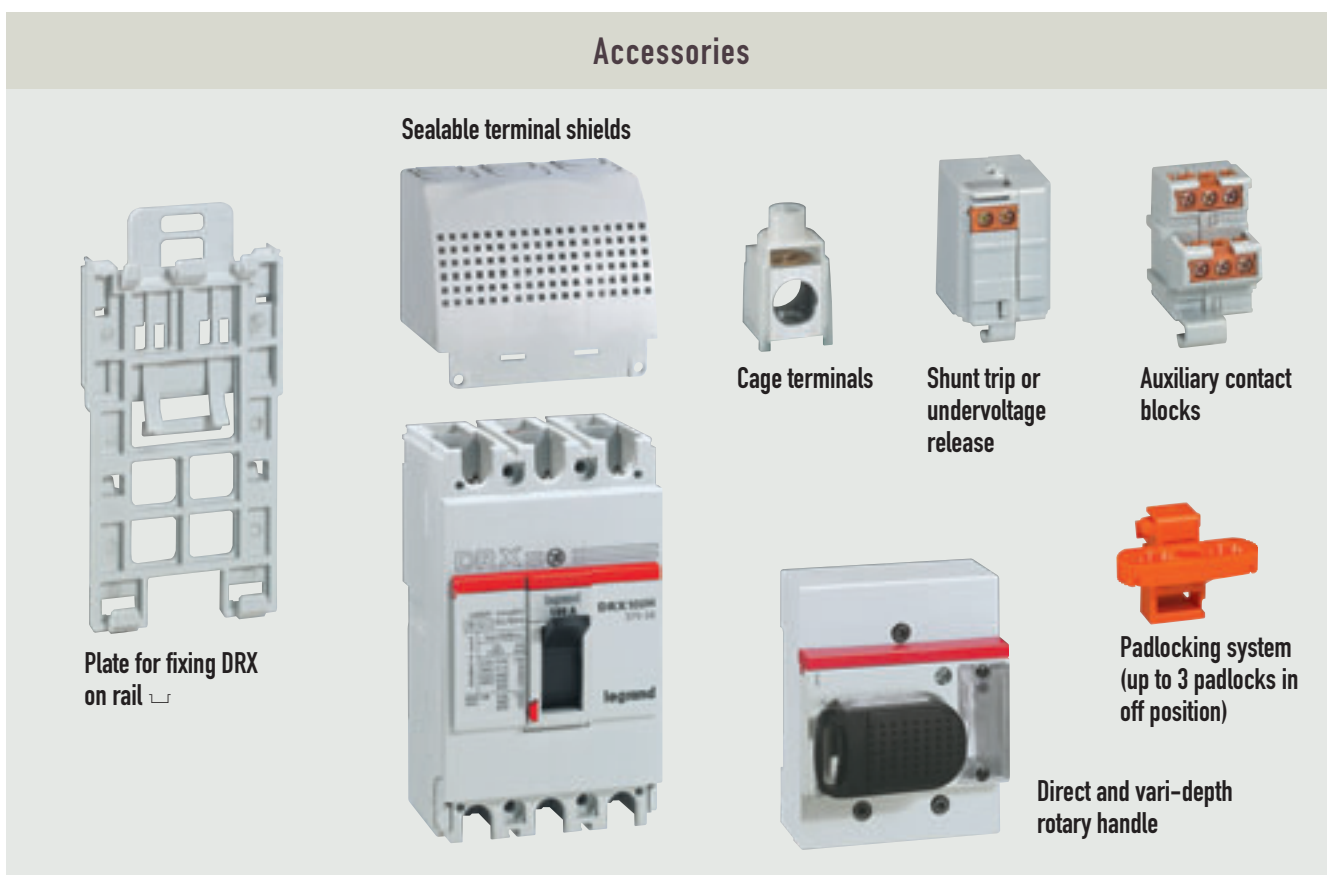





TECHNICAL CHARACTERISTICS

1 ELECTRICAL FEATURES

	DRX 100	DRX 250
Rated operating voltage U_e	600 V AC - 50/60 Hz	600 V AC - 50/60 Hz
Rated insulation voltage U_i	690 V AC - 50/60 Hz	690 V AC - 50/60 Hz
Rated impulse withstand Voltage U_{imp}	6 kV	6 kV
Category of use	A	A
Nominal rating at 40°C I_n (A)	15-20-25-30-40-50-60-75-100	125-150-175-200-225-250
Thermal current value I_r	I_n (fixed)	I_n (fixed)
Magnetic current value I_m	10 I_n (fixed)	10 I_n (fixed)
Ultimate breaking capacities I_{cu} at 380-415 V AC	10 kA, 20 kA, 35 kA	18 kA, 25 kA, 36 kA

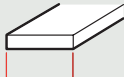
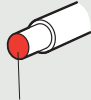
DRX moulded case circuit breakers (continued)

2 CONNECTION

Maximum capacities for each pole								
Device	Connection method	Busbars	Conductors		Copper terminals		Aluminium terminals	
		 Width (mm)	 Cross-section (mm ²)		Standard	Compacts	Standard	Compacts
			rigid	Flexible	 S - Ø (mm ² -mm)	 S - Ø (mm ² -mm)	 S - Ø (mm ² -mm)	 S - Ø (mm ² -mm)
DRX 100	Direct on plate	17			16-8	35-8		50-8
	Cage terminals		50	35				
DRX 250	Direct on plate	25			95-10		120-10	
	Cage terminals		150	120				

3 DIMENSIONS

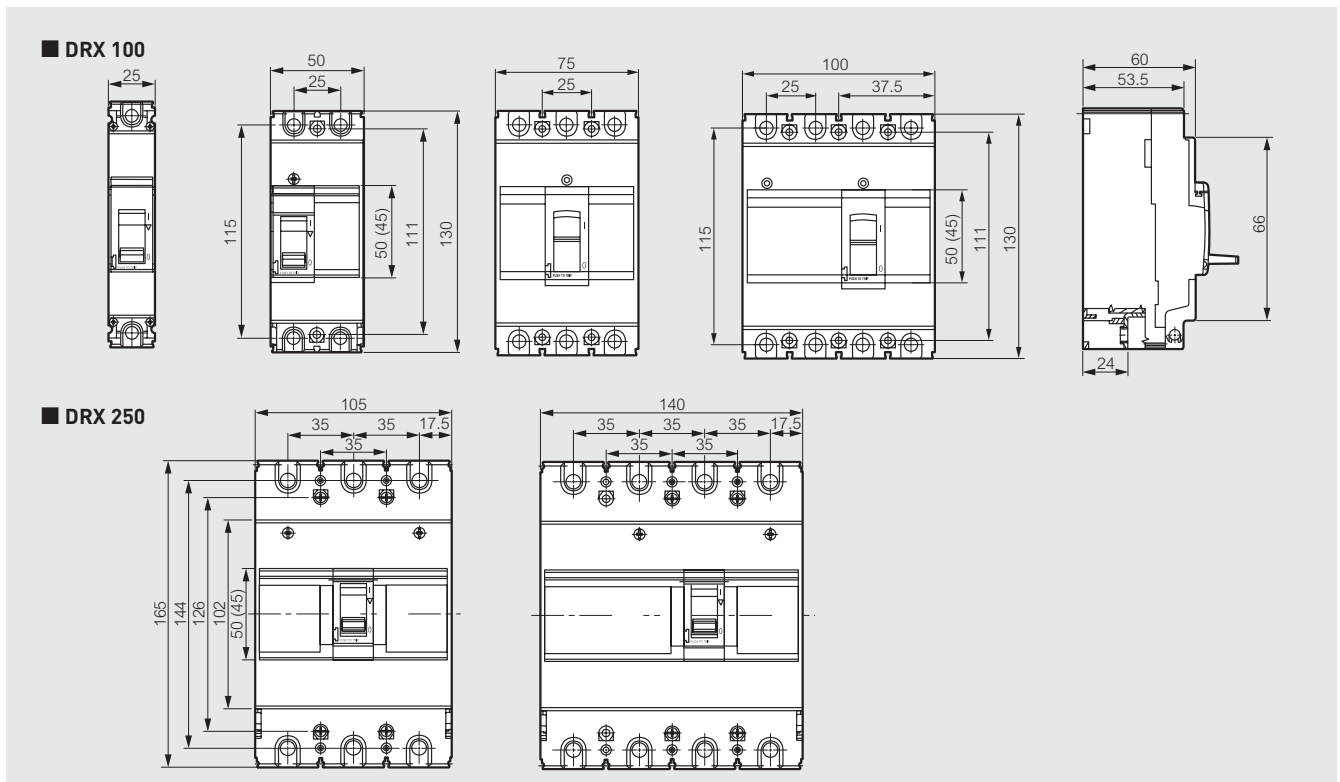

4 TRIPPING CURVES

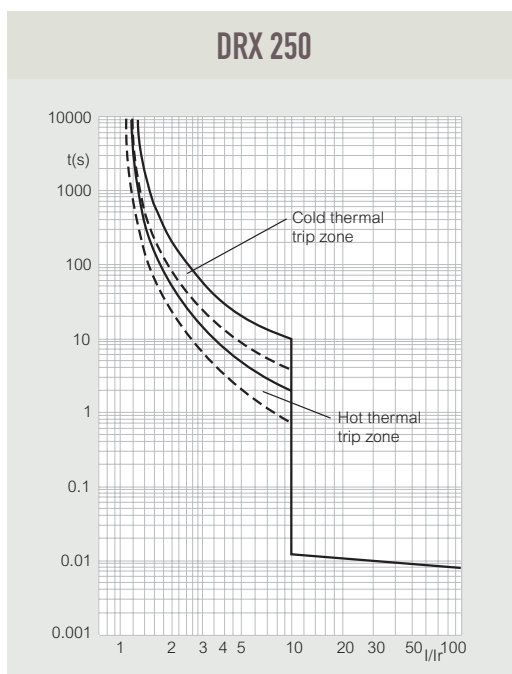
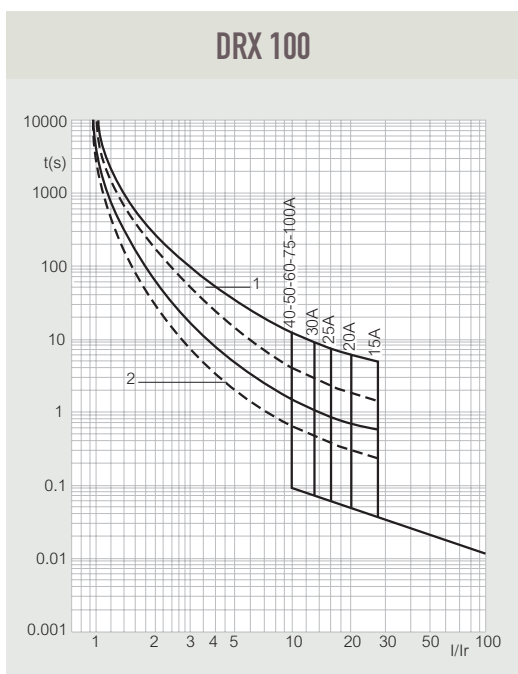

5 CURRENT LIMITATION CURVES

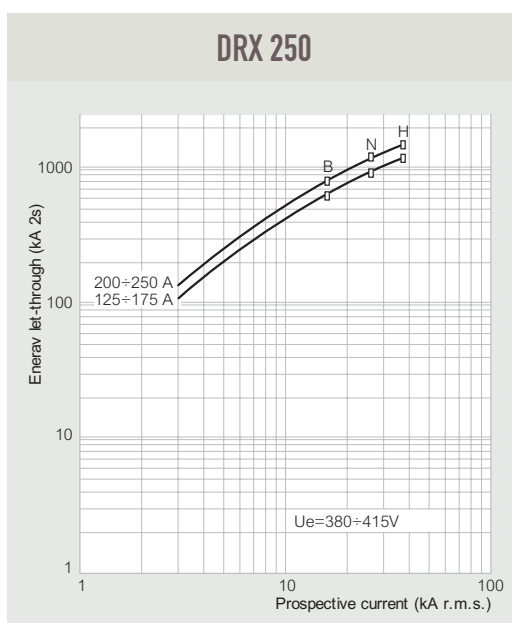
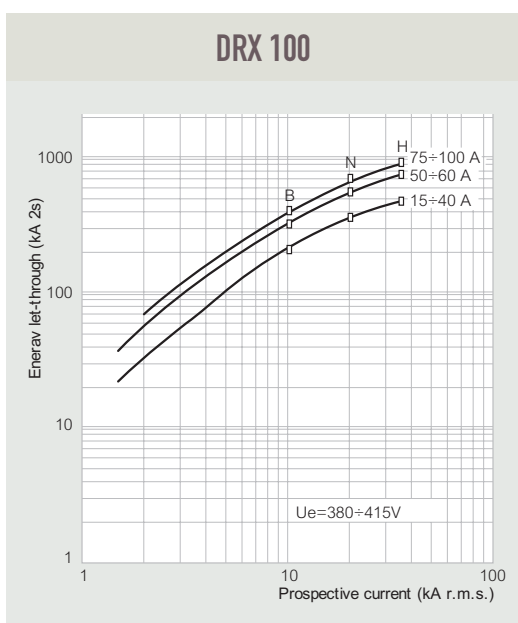

Lexic DX modular circuit breakers

Legrand Lexic modular circuit breakers offer an extensive range of characteristics and can be used to organise distribution in rows as required, up to 125 A. It is the ideal universal solution for all commercial and residential installations.

THE LEXIC DX MODULAR RANGE

The Legrand DX range of circuit breakers is comprehensive, versatile, flexible and suitable for all segments. It has been designed for the convenience of users and installers.

DX circuit breakers are available with B, C and D curves and ratings ranging from 0.5 to 125 A, with breaking capacities from 10 kA to 50 kA.

They can take signalling and control auxiliaries, which are common to the whole range, and also adaptable earth leakage modules.

Most of the devices are fitted with a double clip that enables them to be dismantled independently of one another. Connecting them is totally safe, using IP 2x terminals with tightening on the front panel.

The control switch handle has a red-green ON-OFF indicator.

Their performance in combination with other devices is excellent (see p. 140).

They undergo rigorous individual inspection and are certified by numerous certification bodies.

The range comprises:

- DX: thermal-magnetic circuit breakers
 - 1P, 1P+N, 2P, 3P, 3P+N, 4P
 - Curves B and C - breaking capacity: $\boxed{6\ 000}$ - 10 kA
 - Curve D - breaking capacity : 10 to 25 kA.
- DX-H: thermal-magnetic circuit breakers with high breaking capacity
 - 1P, 1P+N, 2P, 3P, 3P+N, 4P
 - Curve C - breaking capacity: $\boxed{10\ 000}$ - 25 to 12.5 kA
- DX-L: thermal-magnetic circuit breakers with high breaking capacity
 - 2P, 3P, 4P
 - Curve C - breaking capacity : 50 kA.

The breaking capacities are given in accordance with standards IEC 60898-1 and IEC 60947-2 (see p. 06)

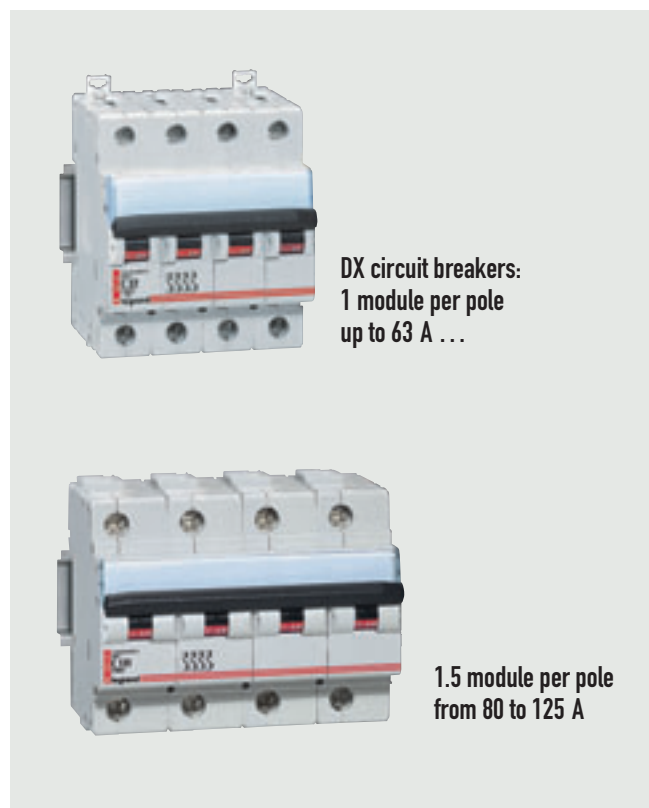

Front panel, marking and dimensions of modular circuit breakers

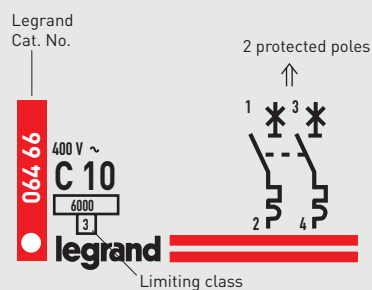
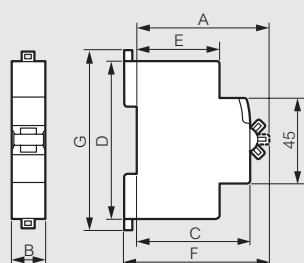
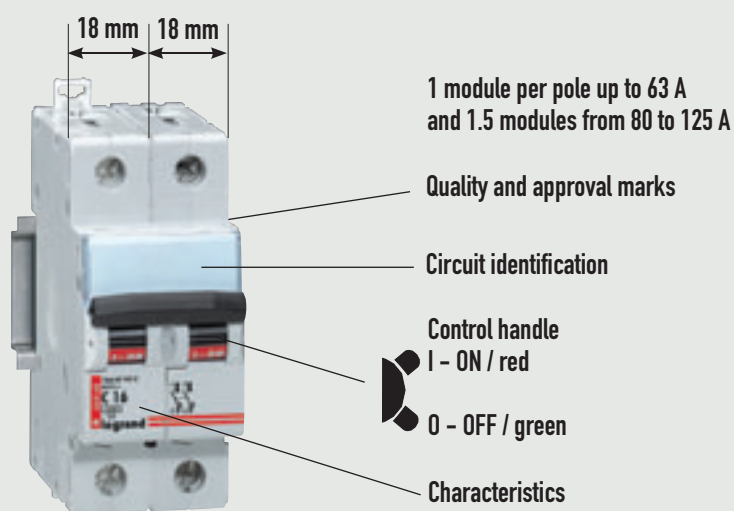

DX 2-pole MCB

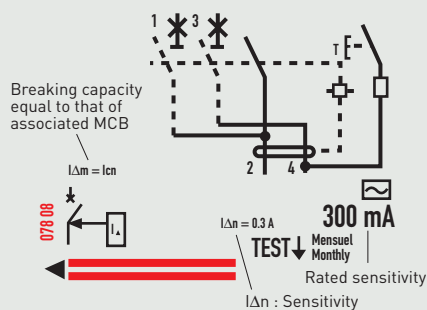

DX add-on module

	A	B				C	D	E	F	G	
		1P	1P+N	2P	3P						4P
Thermal-magnetic MCBs LR, DX, DX-H up to 63 A	70		17.7	35.6	53.4	71.2	60	83	44	76	94
Thermal-magnetic MCBs DX-L, DX D curve, DX-H from 80 to 125 A	70	26.7		53.4	80.1	106.8	60	83	44	76	89
Earth leakage modules $\leq 63 A$	70			35.6	53.4	53.4	60	93	44	76	99
Earth leakage modules from 80 to 125 A	70	17.7		71.1	107.2	107.2	60	88	44	76	89

Lexic DX modular circuit breakers (continued)

CHARACTERISTICS OF DX CIRCUIT BREAKERS

		DX 10 kA		DX 6000 - 10 kA			
Number of poles		1P	3P	1P	1P+N	2P/3P/4P	3P+N
Rated current I_n (A) at 30°C		6/10/16 20 /25/32 40/50 /63	6/10/16 20 /25/32 40/50 /63	1/2/3/4/6 10/16/20 25/32/40 50/63	0.5/1/2/3/4 6/10/16/20 25/32/40	1/2/3/4/6 10/16/20 25/32/40 50/63	6/10/16 20/25/32 40/50/63
Type of curve		B and C	B and C	B and C	B and C	B and C	B and C
Nominal voltage (with standard tolerance)		230/400 V	400 V	230/400 V	230 V	400 V	400 V
Nominal frequency		50/60 Hz	50/60 Hz	50/60 Hz	50/60 Hz	50/60 Hz	50/60 Hz
Operating voltage (50/60 Hz) \pm 10%		240/415 V	415 V	415 V	240 V	415 V	415 V
Breaking capacity I_{cn} according to EN 60898-1 (50/60 Hz)	127/230 V	-	-	6000 A	6000 A	6000 A	6000 A
	230/400 V	-	-	6000 A	6000 A	6000 A	6000 A
Breaking capacity I_{cu} according to EN 60947-2 (50/60 Hz)	127/230 V	10 kA	10 kA	10 kA	10 kA	curve B: 25 kA curve C: $I_n \leq 32$ A: 25 kA $I_n > 32$ A: 20 kA	curve B: 25 kA curve C: $I_n \leq 32$ A: 25 kA $I_n > 32$ A: 20 kA
	230/400V	10 kA	10 kA	10 kA	10 kA	10 kA	10 kA
Standard breaking capacity I_{cs} according to EN 60947-2		100%	100%	100%	100%	100%	100%
Rated insulation voltage U_i (degree of pollution 2)		500 V	500 V	500 V	500 V	500 V	500 V
Rated impulse withstand current I_{imp} (kV)		4 kV	4 kV	4 kV	4 kV	4 kV	4 kV
Endurance (operating cycles)	mechanical	20 000	20 000	20 000	20 000	20 000	20 000
	electrical	10 000	10 000	10 000	10 000	10 000	10 000
Dielectric strength between 0 and 2000 m		2500 V	2500 V	2500 V	2500 V	2500 V	2500 V
Remote control						•	•
Add-on module						•	•
Operating temperature		-25°C to +70°C	-25°C to +70°C	-25°C to +70°C	-5°C to +40°C	-25°C to +70°C	-25°C to +70°C

	DX-H 10 000 - 25 kA					DX 6 000 - 15 kA curve D	DX-L 50 kA	
	1P	1P+N	2P	3P/4P	3P+N	1P	2P/3P/4P	2P/4P
	2/3/6/10 13/16/20 25/32/40 50/63/80 100/125	2/3/6/10 13/16/20 25/32/40 50/63	2/3/6/10 13/16/20 25/32/40 50/63/80 100/125	2/3/6/10 13/16/20 25/32/40 50/63/80 100/125	6/10 13/16/20 25/32/40 50/63	1/2/3/6 10/16/20 25/32/40 50/63	1/2/3/6 10/16/20 25/32/40 50/63/80 100/125	10/16/20 25/32/40 50/63
	B and C	B and C	B and C	B and C	B and C	D	D	C
	230/400 V	230 V	400 V	400 V	400 V	230/400 V	400 V	400 V
	50/60 Hz	50/60 Hz	50/60 Hz	50/60 Hz	50/60 Hz	50/60 Hz	50/60 Hz	50/60 Hz
	415 V	240 V	415 V	415 V	415 V	415 V	415 V	415 V
	10000	10000	10000	10000	10000	6000 A	6000 A	25000
	10000	10000	10000	10000	10000	6000 A	6000 A	25000
	25 kA	25 kA	In ≤ 40 A: 50 kA In > 40 A: 25 kA	In ≤ 40 A: 50 kA In 50/63 A: 25 kA In > 63 A: 16 kA	In ≤ 40 A: 50 kA In 50/63 A: 25 kA In > 63 A: 16 kA	In ≤ 32 A: 25 kA In ≤ 63 A: 20 kA	In ≤ 32 A: 25 kA In ≤ 63 A: 20 kA In > 63 A: 16 kA	70 kA
	In ≤ 20 A: 25 kA In 25 A: 20 kA In 32 A: 15 kA In > 32 A: 12.5 kA	In ≤ 20 A: 25 kA In 25 A: 20 kA In 32/40 A: 15 kA In > 40 A: 12.5 kA	In ≤ 20 A: 30 kA In 25 A: 25 kA In 32/40 A: 20 kA In > 40 A: 15 kA In > 63 A: 16 kA	In ≤ 20 A: 25 kA In 25 A: 20 kA In 32/40 A: 15 kA In > 40 A: 12.5 kA	In ≤ 20 A: 25 kA In 25 A: 20 kA In 32/40 A: 15 kA In > 40 A: 12.5 kA	In ≤ 32 A: 15 kA In > 32 A: 10 kA	In ≤ 32 A: 15 kA In > 32 A: 10 kA	50 kA
	75%	75%	75%	75%	75%	75%	75%	75%
	500 V	500 V	500 V	500 V	500 V	500 V	500 V	500 V
	4 kV	4 kV	4 kV	4 kV	4 kV	4 kV	4 kV	4 kV
	20 000	20 000	20 000	20 000	20 000	20 000	20 000	20 000
	10 000	10 000	10 000	10 000	10 000	10 000	10 000	10 000
	2500 V	2500 V	2500 V	2500 V	2500 V	2500 V	2500 V	2500 V
		•	•	•	•		•	
		•	•	•	•		•	•
	-25°C to +70°C	-25°C to +70°C	-25°C to +70°C	-25°C to +70°C	-25°C to +70°C	-25°C to +70°C	-25°C to +70°C	-25°C to +70°C

Lexic DX modular circuit breakers (continued)

AUXILIARIES AND MOTOR-DRIVEN CONTROLS FOR DX

Each device can take up to 3 auxiliaries: 2 signalling auxiliaries + 1 control auxiliary or a motor-driven control.

1 CURRENT SHUNT TRIPS

These are common to DX, DX-H and DX-L circuit breakers, RCBs, RCCBs and DX-IS isolating switches. They are used to trip the device remotely. They are always connected in series with an NO contact.
 Nominal voltage : - 12-48 V AC/DC
 - 110-415 V AC/110-125 V DC
 Tolerance on nominal voltage: 0.7 to 1.1 Un

2 UNDERVOLTAGE RELEASES

These are common to DX, DX-H and DX-L circuit breakers, RCBs, RCCBs and DX-IS isolating switches. They trip the device when there is a significant reduction or total absence of control voltage, with a time delay adjustable from 0 to 300 ms.
 Nominal voltage : 230 V AC
 Minimum voltage: 0.55 Un ± 10%

3 AUXILIARY CONTACTS AND FAULT SIGNAL CONTACTS

These are used for remote feedback of information on the state of the circuit breaker. Auxiliary contacts (AC) indicate whether the device is open or closed, whereas fault signal contacts (FS) indicate that the device is in the "tripped" position following operation of the protection unit, an auxiliary release or a residual current device.
 Permissible current: 6 A at 250 V AC, 3 A at 400 V AC, 4 A at 24 V DC, 1 A at 60 V DC and 0.5 A at 230 V DC

4 MOTOR-DRIVEN CONTROLS

These can be used with Lexic DX and DX-H circuit breakers (except 1-Pole) and RCBs ≤ 63 A. They are used to open and close the circuit breakers remotely. They incorporate signalling and fault signalling functions.
 Nominal control and supply voltage Uc: 230 V AC
 Operating voltages: From 0.85 Uc to 1.10 Uc
 Nominal frequency: 50 Hz
 Does not operate at 60 Hz or with DC supply
 Minimum time between 2 successive commands: 1 s up to 10 consecutive commands, 10 s thereafter
 Power consumption in rest mode: 5 W
 Maximum power consumption: 30 VA for breaking or making
 Minimum control pulse duration: 20 ms
 Circuit breaker opening or closing time at Uc: < 1 s

+ The module for use with the circuit breaker, Cat. No. 073 83, meets requirements for continuity of service by giving the reset command automatically.

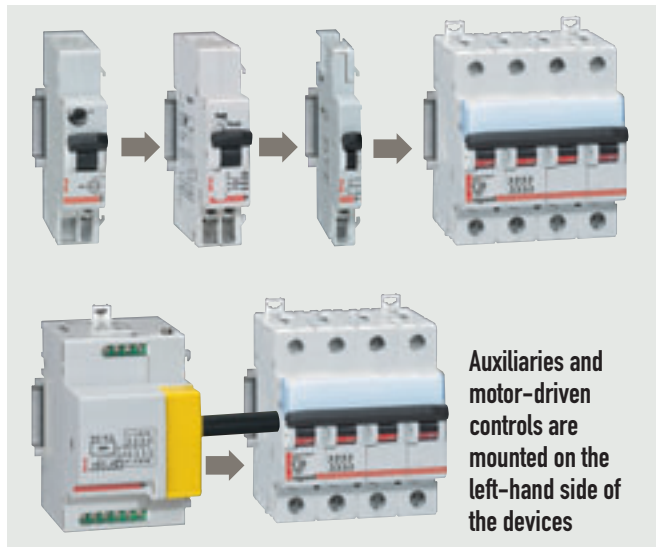

5 STOP&GO MOTOR-DRIVEN CONTROLS

Can be used with Lexic DX and DX-H circuit breakers and RCBOs ≤ 63 A with screw terminals.

They automatically reset the devices with which they are used, in the event of false tripping after a transient fault, eg: lightning (applications: air cond., fridges, etc.)

The status of the installation is checked before resetting. Any permanent fault (residual current fault or short circuit) is indicated by an audible alarm and an indicator light.

Control voltage: 230 V AC



< STOP&GO motor-driven controls Cat. Nos. 073 81/82 restore the current totally safely in the event of false tripping

CONNECTING DX

All the devices are available with incoming and outgoing screw terminals, which take rigid or flexible cables as well as copper prong-type busbars.

Connection cross-section of screw terminals

Copper cable	rigid	flexible
DX, DX-H, DX curve D 15 kA, earth leakage modules ≤ 63 A	35 mm ²	25 mm ²
DX-H, 80, 100, 125 A earth leakage modules, DX-L, DX curve D 25 kA	70 mm ²	50 mm ²
Auxiliaries	2.5 mm ²	2.5 mm ²



Distribution via prong-type busbar may be implemented using the upper or the lower terminals on DX devices, according to local work practices.

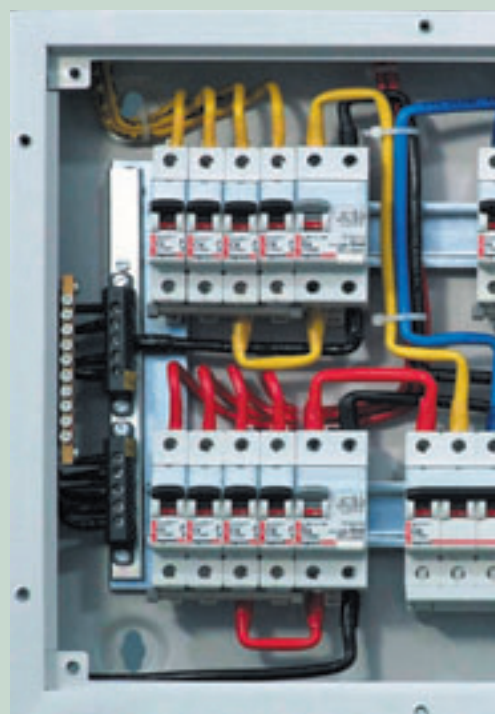

Lexic DX modular circuit breakers (continued)

CHOICE OF PROTECTION DEVICES ACCORDING TO THE NEUTRAL EARTHING SYSTEM

As a general rule all live conductors (phase and neutral) must be protected against overloads and short-circuits. It is however possible to do away with this requirement for the neutral conductor in certain configurations.

Main permitted layouts according to the neutral earthing system and the type of circuit

Neutral earthing system										
TT	●	● (1)	●	●	● (1)		●	●		
TN-S	●	● (1)	●	●	● (1)		●	●		
TN-C	●			●					●	●
IT			●	●	● (2)	● (2)	●	●		

[1] In TT and TN systems, it is possible to use circuit breakers with unprotected neutral pole if the cross-section of the neutral conductor is the same as that of the phase conductors. However, the neutral conductor must be protected if there is a risk of it breaking upstream of the device and there is no residual current protection (TN system).

[2] In IT systems with a distributed neutral conductor, it is possible to use circuit breakers with unprotected neutral pole if a residual current protection device, with a sensitivity of less than 15% of the current permissible in the neutral, is placed upstream. This device must break all the poles, including the neutral. This situation should be limited to the supply of devices which can withstand the full voltage (between phases) with no risk of fire.

! Breaking of the neutral

If the neutral breaks (maximum imbalance), the neutral point moves according to the load of each phase. The greater the load on a phase (phase 1 in this diagram), the lower its impedance. V_1 drops, V_2 and V_3 increase and may reach the value of the phase-to-phase voltage on the phases with the lowest loads, which generally supply the most sensitive devices.

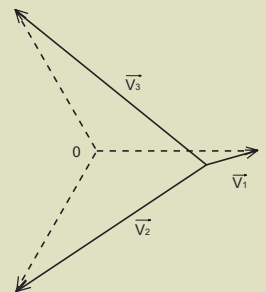

SPECIAL APPLICATIONS AND DERATING

1 USE IN AN IT SYSTEM

In this case the breaking capacity of a single pole must be taken into account.

Breaking capacity of one pole at 400 V according to EN 60947-2		
DX 1P+N curves B and C		1.5 kA
DX curves B and C	< 63 A	3 kA
DX-H curves B and C	< 20A	6 kA
	25 A	5 kA
	32 and 40 A	4 kA
	50 and 63 A	3 kA
DX-L curves B and C	80 and 125 A	4 kA
	10 to 63 A	6 kA
DX curve D 15 kA	< 32 A	4 kA
	40 to 125 A	3 kA
DX curve D 25 kA	10 to 40 A	6 kA

2 HIGH TEMPERATURES

A standard circuit breaker is set to operate at I_n at an ambient temperature of 30°C.

For Lexic circuit breakers the values in the following table are to be used.

When several circuit breakers are installed side by side and operate simultaneously, the heat dissipation of one pole is limited. This leads to a rise in the operating temperature of the circuit breakers, causing false tripping. It is advisable to apply additional coefficients according to the operating currents:

- 1 to 3 devices: 1
- 4 to 6 devices: 0.8
- 7 to 9 devices: 0.7
- More than 10 devices: 0.6



To avoid using the coefficients, good ventilation must be provided and the devices kept away from one another.

Derating (A) of DX, DX-H, DX-L and DX-D according to the temperature

I_n (A)	Ambient temperature (°C)									
	-25	-10	0	10	20	30	40	50	60	70
0.5	0.64	0.6	0.57	0.55	0.52	0.5	0.47	0.45	0.42	0.40
0.8	1.02	0.96	0.92	0.88	0.84	0.8	0.76	0.72	0.69	0.66
1	1.25	1.17	1.1	1.07	1.03	1	0.97	0.93	0.90	0.87
2	2.5	2.34	2.21	2.14	2.06	2	1.94	1.86	1.80	1.74
3	3.75	3.5	3.36	3.24	3.12	3	2.88	2.76	2.64	2.52
4	5	4.7	4.44	4.28	4.12	4	3.88	3.72	3.6	3.48
6	7.5	7	6.6	6.4	6.18	6	5.8	5.6	5.4	5.2
8	10.2	9.6	9.2	8.8	8.4	8	7.6	7.2	6.9	6.6
10	12.2	11.5	11.1	10.7	10.3	10	9.7	9.3	9	8.7
13	16.3	15	14.3	13.9	13.4	13	12.6	12.1	11.7	11.3
16	19.7	18.7	18	17.3	16.6	16	15.4	14.7	14.1	13.5
20	24.6	23.2	22.4	21.6	20.8	20	19.2	18.4	17.6	16.8
25	31.2	29.5	28.3	27.2	26	25	24	22.7	21.7	20.7
32	40	37.8	36.5	34.9	33.3	32	30.7	29.1	27.8	26.5
40	50	48	46	44	42	40	38	36	34	32
50	62.5	60	57.5	55	52.5	50	47.5	45	42.5	40
63	78.1	75.6	72.5	69.9	66.1	63	59.8	56.1	52.9	50.4
80	102	96	92	88	84	80	76	72	69	66
100	124	118	114	110	105	100	95	90	86	82
125	155	147	141	137	131	125	119	113	108	103

3 400 HZ POWER SUPPLY

The stated characteristics for the devices assume a frequency of 50/60 Hz. They should be corrected for use at 400 Hz.

1-module neutral + phase DX and DX 80 A, 100 A and 125 A circuit breakers have their magnetic threshold increased by 35%.

This increase is 45% for 1, 2, 3 and 4-pole DX and DX-H circuit breakers from 1 to 63 A.

The other characteristics, such as the nominal rating for operation and the thermal thresholds, do not change. This is the case for all ratings.

Lexic DX modular circuit breakers (continued)



4 DC OPERATION

DX and DX-H Lexic circuit breakers (1P/2P/3P/4P - $I_n \leq 63$ A) designed to be used with 230/400 V AC supplies, can also be used with DC supplies. In this case, the maximum value of the magnetic trip threshold must be multiplied by 1.4. For example: for a curve C circuit breaker whose trip threshold is between 5 and 10 I_n with an AC supply, the trip threshold will be between 7 and 14 I_n with a DC supply.

The thermal tripping curve is the same as with an AC supply.

The maximum operating voltage is 80 V per pole (60 V for single-pole + neutral). For voltages above this value, several poles must be wired in series.

The breaking capacity is 4000 A for a single-pole circuit breaker at maximum voltage (80 V DC per pole) At other voltages, the breaking capacities are given in the table below according to the number of poles in series.

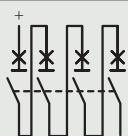
Breaking capacity I_{cu} according to EN 60947-2				
				
	Single pole	2-pole	3-pole	4-pole
DX	≤ 48 V DC	6 kA	6 kA	
	110 V DC		6 kA	6 kA
	230 V DC			
DX-H	≤ 48 V DC	10 kA	10 kA	
	110 V DC		10 kA	10 kA
	230 V DC			

5 SUPPLYING POWER TO FLUORESCENT TUBES

The rating for the protection device should be determined on the basis of an actual rated current (I_B) increased by the K coefficient.

K = 1.8 for compensated tubes ($\cos \varphi \approx 0.85$)

K = 3.4 for non-compensated tubes ($\cos \varphi \approx 0.5$)

With 230 V three-phase distribution:

$$I_B = \frac{P}{230} \times K$$

With 400 V three-phase distribution:

$$I_B = \frac{P}{400 \times \sqrt{3}} \times K$$

P: Sum of powers (in W) of fluorescent fittings depending on models (18 W, 36 W, 58 W, 2 × 36 W, 2 × 58 W, 2 × 80 W, 4 × 18 W, etc).

6 PROTECTION OF CAPACITOR BANKS

The rating for the protection device should be determined on the basis of an actual rated current (I_B) increased by the K coefficient.

$$I_B = \frac{Q \times 1000}{U \times \sqrt{3}} \times K$$

K = 2 for $Q \leq 25$ kVAR

K = 1.8 for $Q \leq 50$ kVAR

K = 1.7 for $Q \leq 100$ kVAR

K = 1.5 for $Q > 100$ kVAR

Q: Capacitor bank reactive power (in kVAR)

U: Nominal voltage of 3-phase supply

PERFORMANCE DATA

Curve B

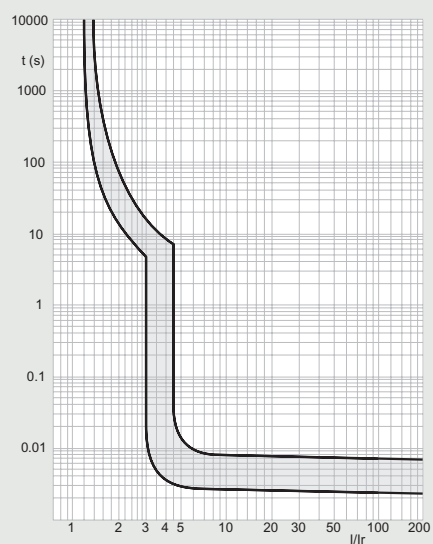

Curve C

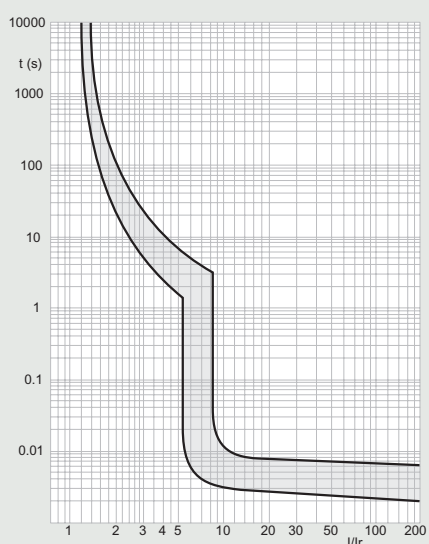

Curve D

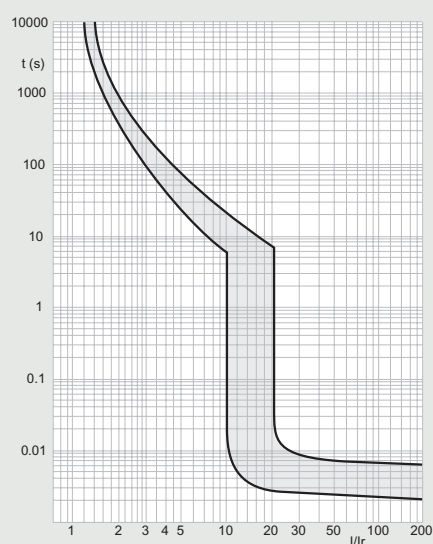

Magnetic thresholds according to the type of curve

Curve	Magnetic threshold
$Z^{(1)}$	2.4 to 3.6 I_n
B	3 to 5 I_n
C	5 to 10 I_n
D	10 to 14 $I_n^{(2)}$

(1) Please consult us

(2) 10 to 20 according to the standards

Lexic DX modular circuit breakers (continued)

THERMAL STRESS LIMITATION CURVES

1 DX 6000 - 10 KA - CURVE B

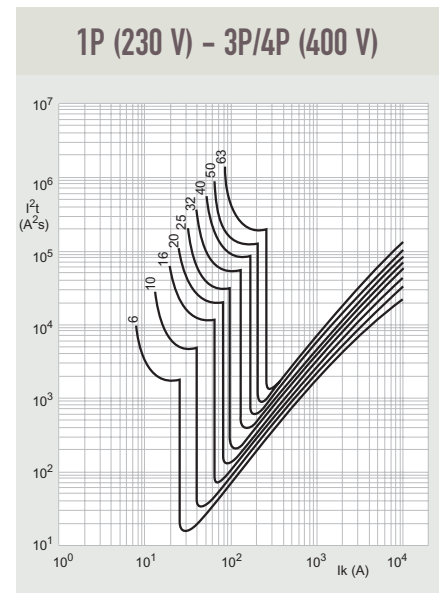
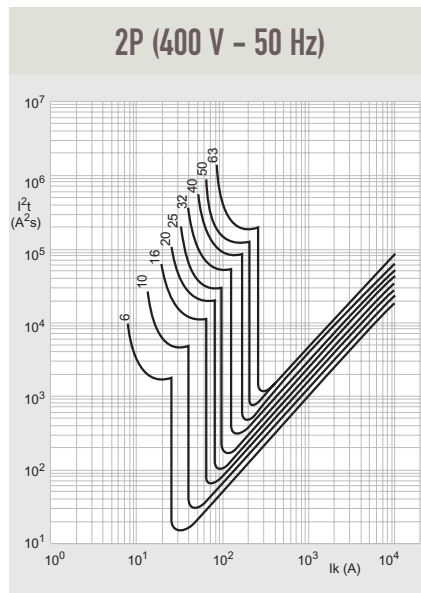
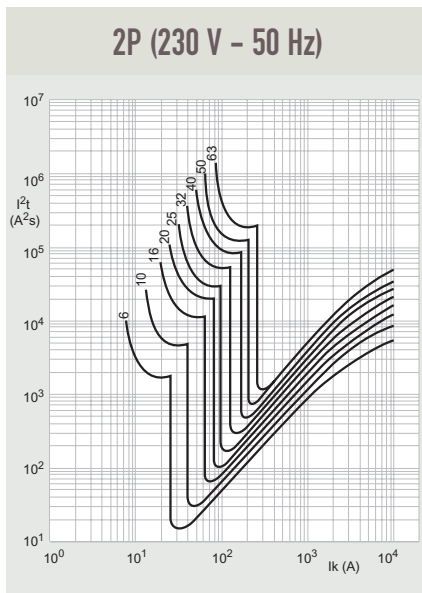

2 DX 6000 - 10 KA - CURVE C

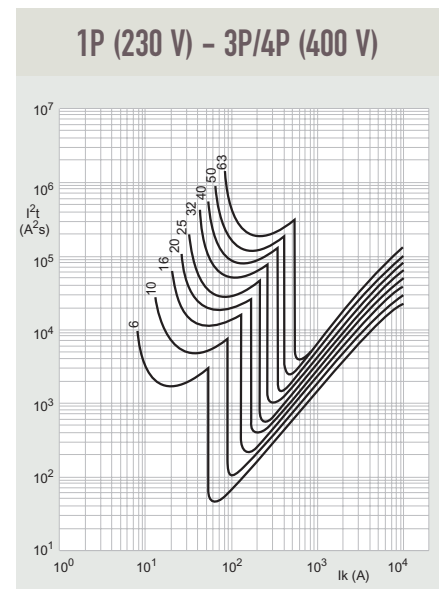
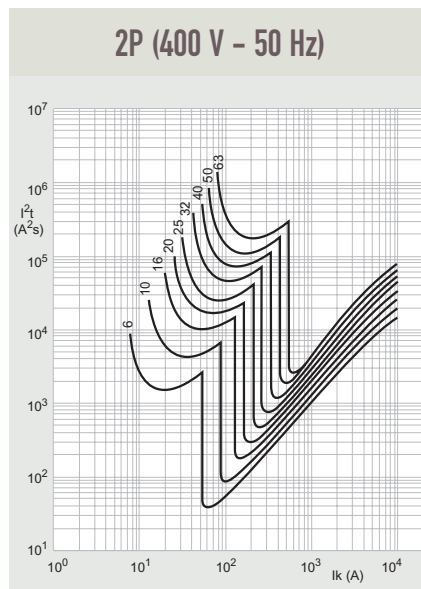
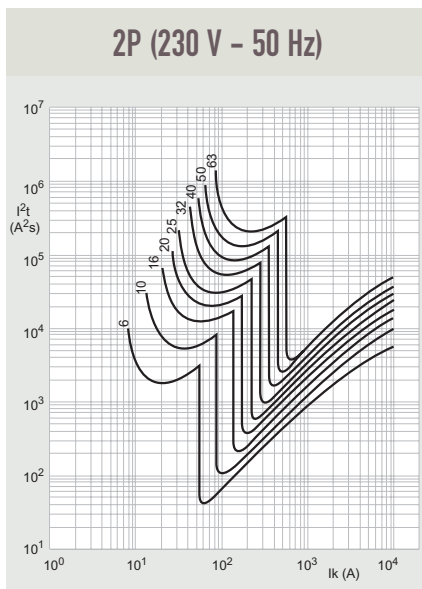

3 DX 6000 - 10 KA - CURVE B AND C

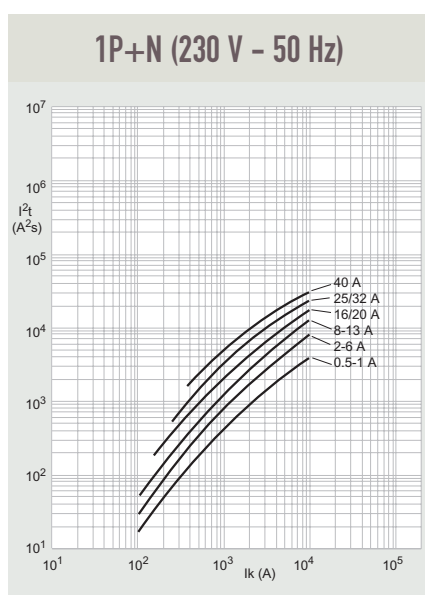

4 DX-H 10 000 - 25 KA - CURVE C - $I_n \leq 63$ A

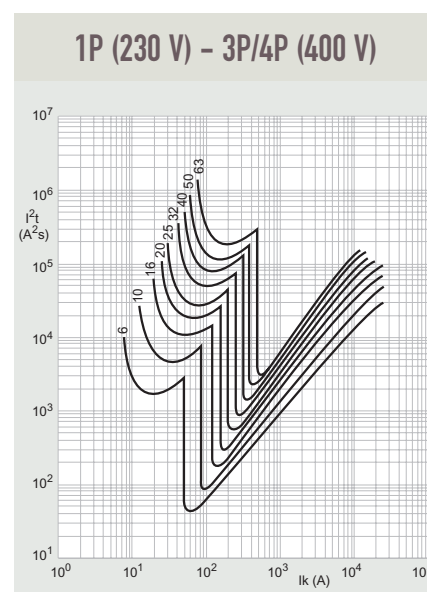
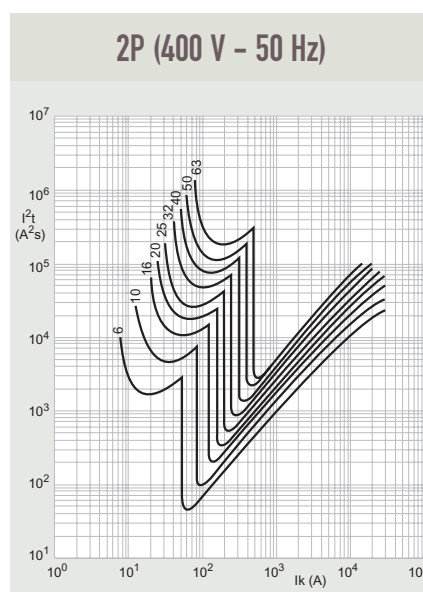
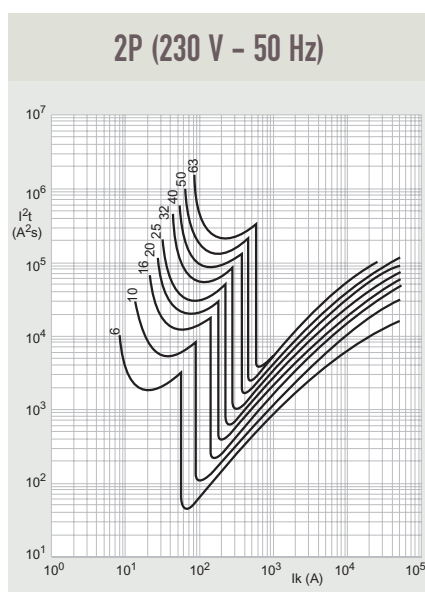

Lexic DX modular circuit breakers (continued)

5 DX-H 10 000 - 25 KA - CURVE C - I_n : 80-100-125 A

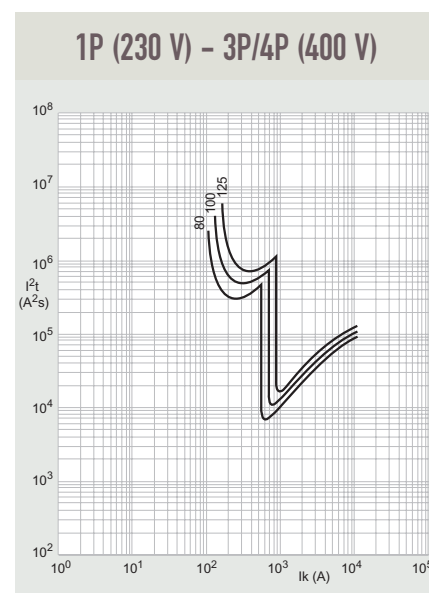
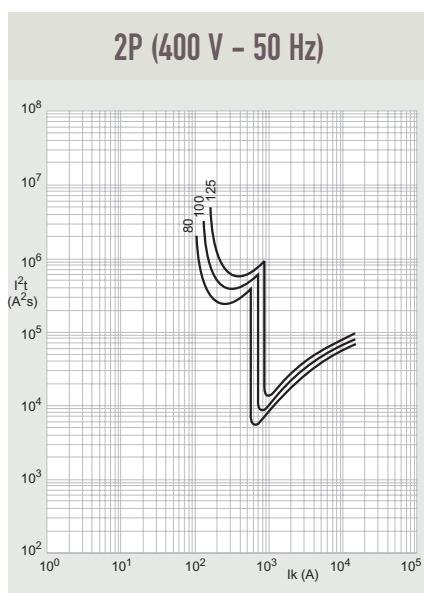
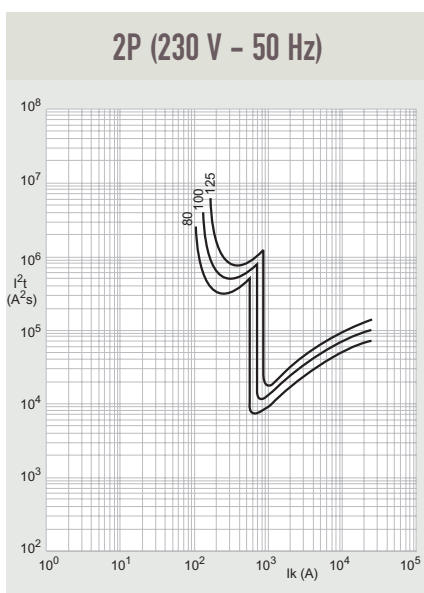

6 DX 6 000 - 15 KA - CURVE D - $I_n \leq 63$ A

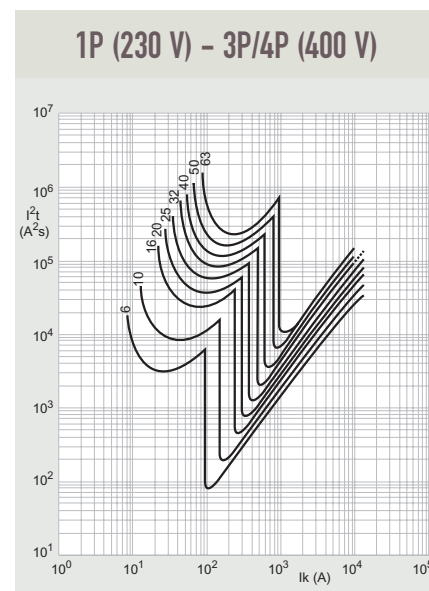
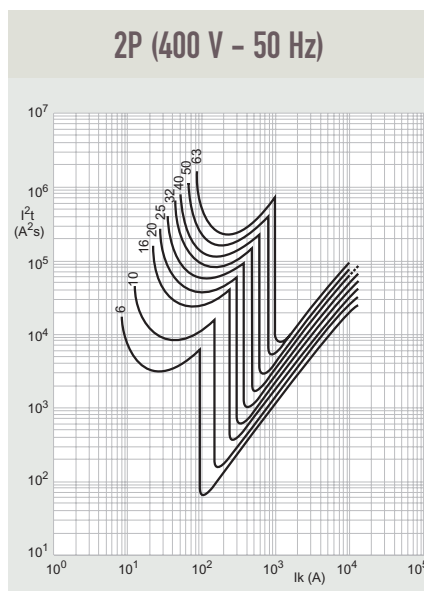
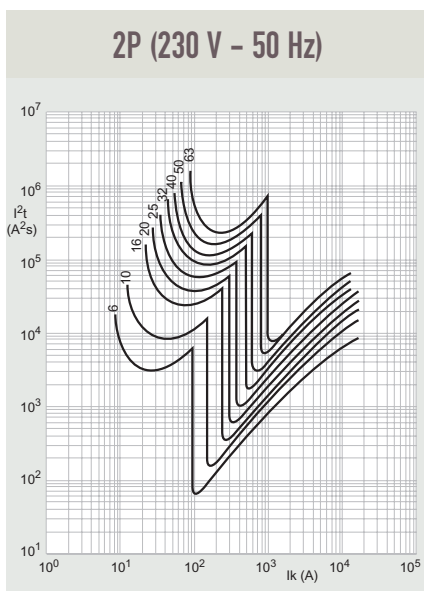

7 DX **6 000** - 15 KA - CURVE D - I_n : 80-100-125 A

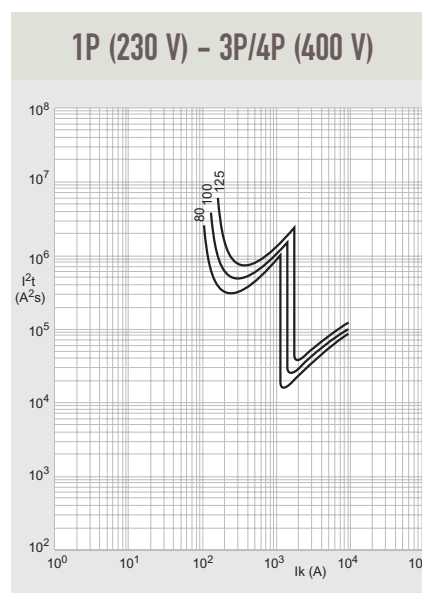
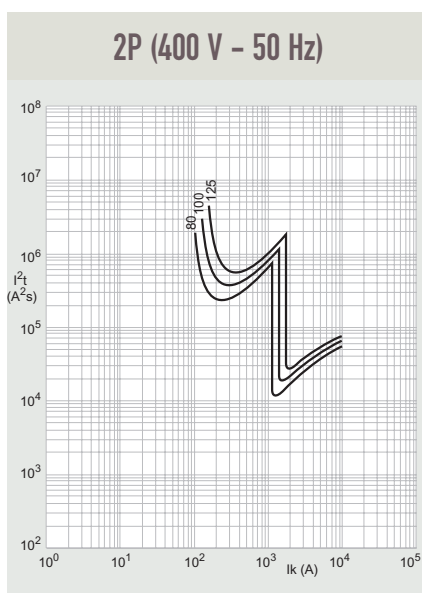
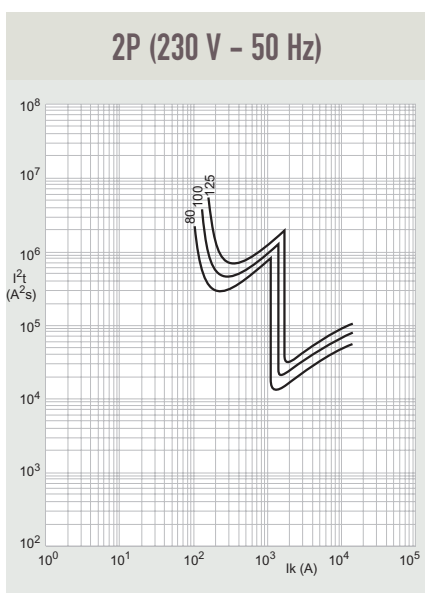

8 DX-L - 50 KA - CURVE C

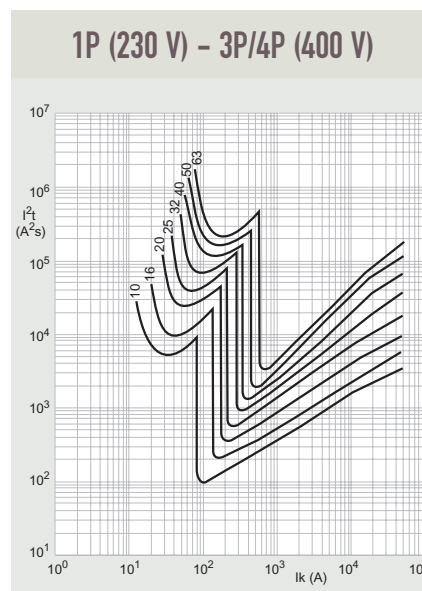
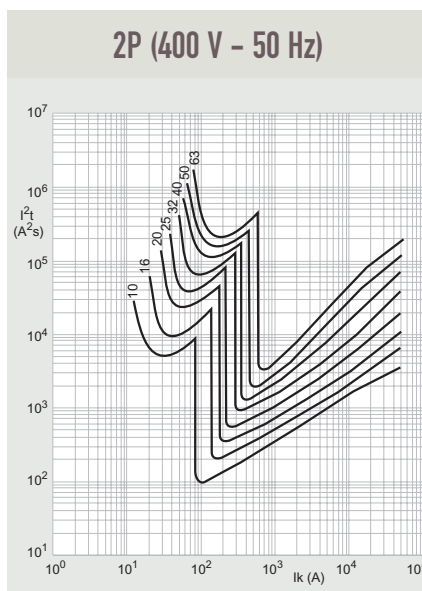
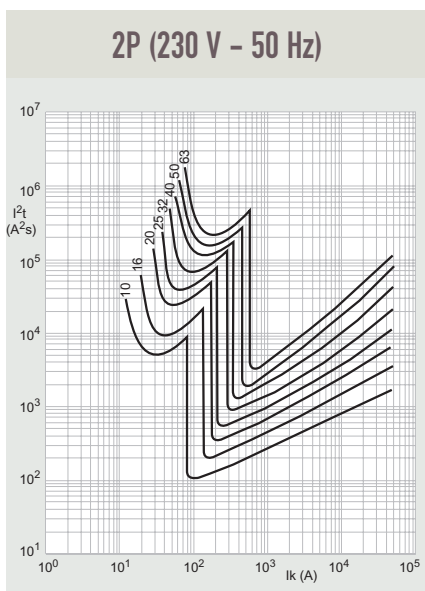

Lexic DX modular circuit breakers (continued)

CURRENT LIMITATION CURVES

1 DX 6000 - 10 KA - CURVE B AND C

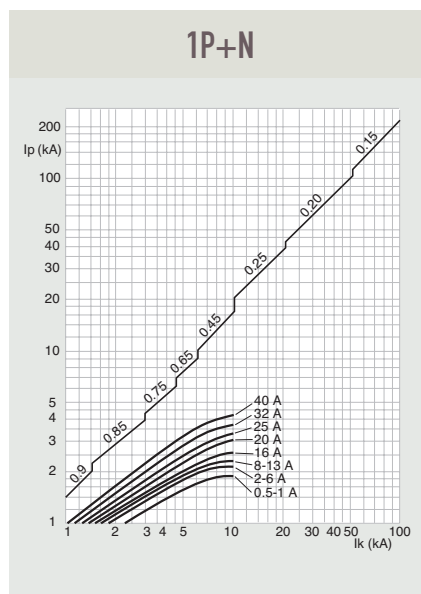
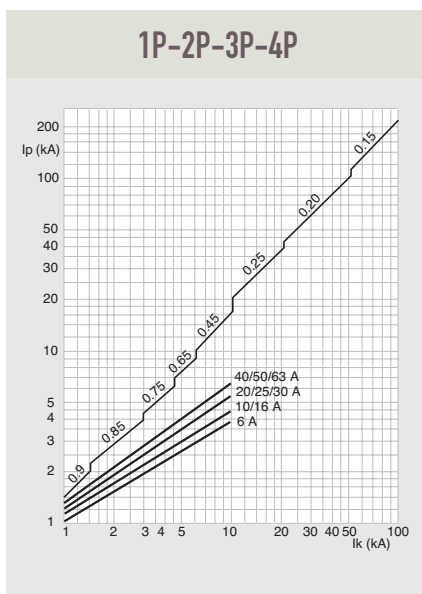

2 DX-H 10000 - 25 KA - CURVE C

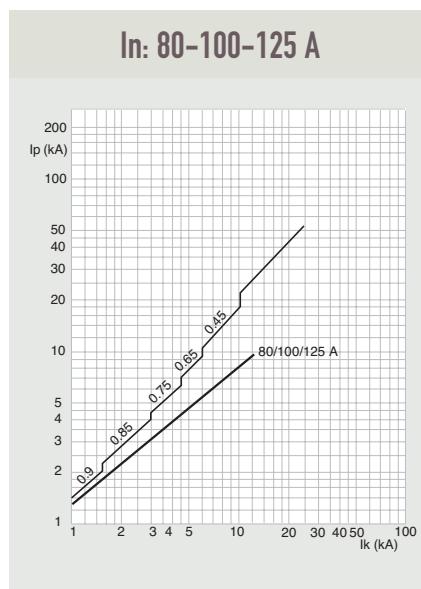
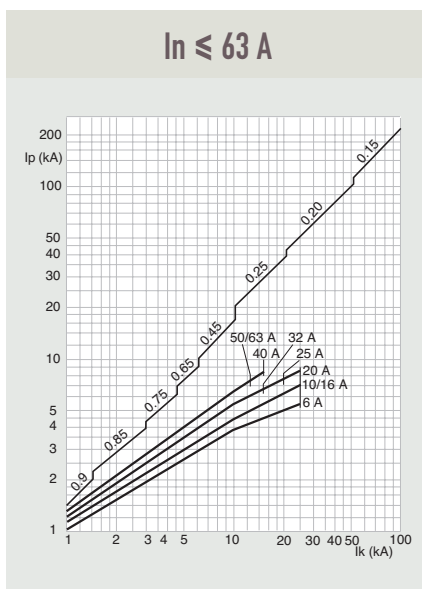

3 DX 6000 - 15 KA - CURVE D

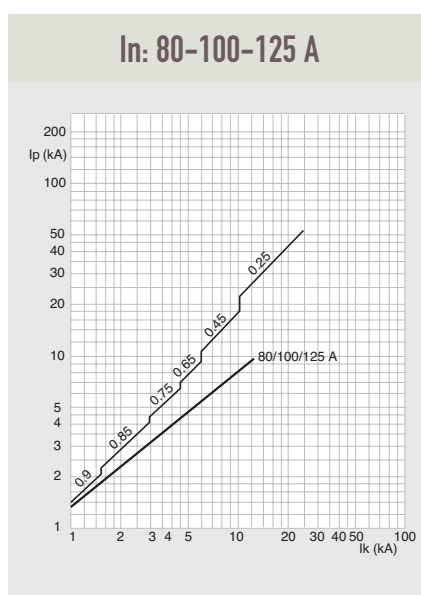
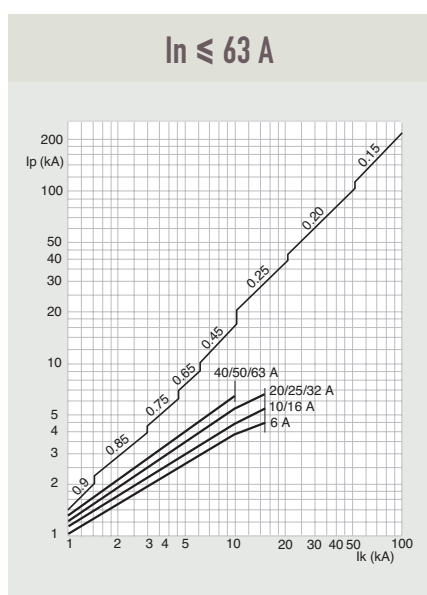

4 DX-L - 50 KA - CURVE C

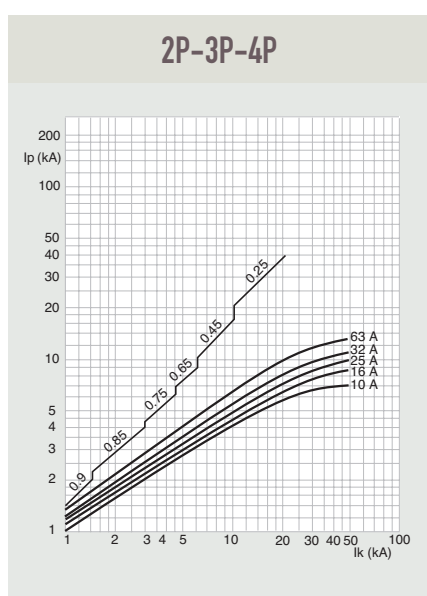

DX-E modular circuit breakers

The simplicity of the DX-E makes it the natural choice for the least complex commercial and residential installations, where there is little requirement for adaptability.

The DX-E range of modular circuit breakers is suitable for most requirements in standard installations:

- 1P, 2P, 3P, 4P
- Curve B and C
- Ratings from 6 to 63 A
- Breaking capacity: $[6000]$ (IEC 60898-1) - 6 kA (IEC 60947-2).

They take auxiliaries from the DX range, apart from adaptable earth leakage modules.

They are mounted on a DIN rail (a single clip) and have a label holder for identification of the circuits.

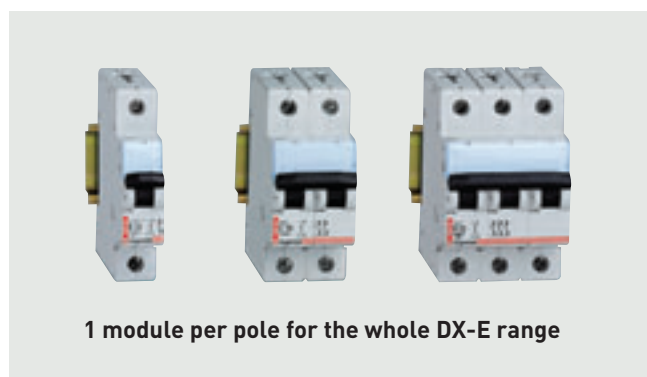

Characteristics of DX-E circuit breakers

	Single pole	2-pole	3-pole	4-pole
Number of poles	1P	2P	3P	4P
Rated current (A) at 30°C	6 - 10 - 13 - 16	6 - 10 - 13 - 16	6 - 10 - 13 - 16	6 - 10 - 13 - 16
Ratings	20 - 25 - 32 40 - 50 - 63	20 - 25 - 32 40 - 50 - 63	20 - 25 - 32 40 - 50 - 63	20 - 25 - 32 40 - 50 - 63
Types of curve	B and C	B and C	B and C	B and C
Nominal voltage Un (V) with standard tolerances	230/400 V	400 V	400 V	400 V
Nominal frequency	50/60 Hz	50/60 Hz	50/60 Hz	50/60 Hz
Maximum operating voltage (50/60Hz) + or - 10%	240/415 V	415 V	415 V	415 V
Breaking capacity Icn (kA) acc. to IEC 60898	127 V/230 V AC	10 kA/6 kA	15 kA/10 kA	10 kA/10 kA
	400 V AC	-	6 kA	6 kA
Breaking capacity Icu (kA) acc. to IEC 60947-2	127 V/230 V AC	10 kA/6 kA	15 kA/10 kA	10 kA/10 kA
	400 V AC	-	6 kA	6 kA
Standard breaking capacity Ics (% Icu)	127 V/230 V AC	100%	100%	100%
	400 V AC	-	100%	100%
Rated insulation voltage Ui (V)	500 V	500 V	500 V	500 V
Rated impulse withstand voltage (kV) Degree of pollution 2	4	4	4	4
Endurance (mechanical and electrical operating cycles)	No-load	20 000	20 000	20 000
	With load	10 000	10 000	10 000
	DC	2000	2000	2000
Dielectric strength	2500 V	2500 V	2500 V	2500 V
Operating temperature	-25°C to +70°C	-25°C to +70°C	-25°C to +70°C	-25°C to +70°C

Performance data

Curve B

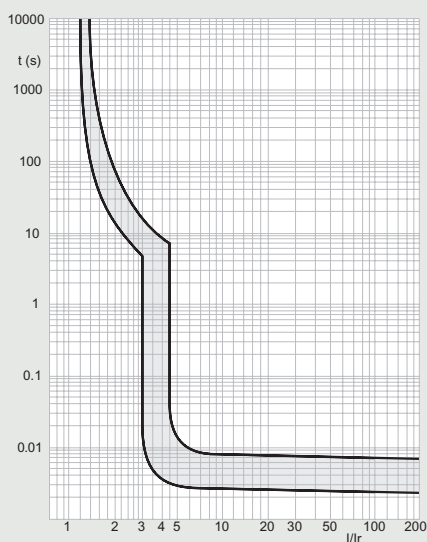

Curve C

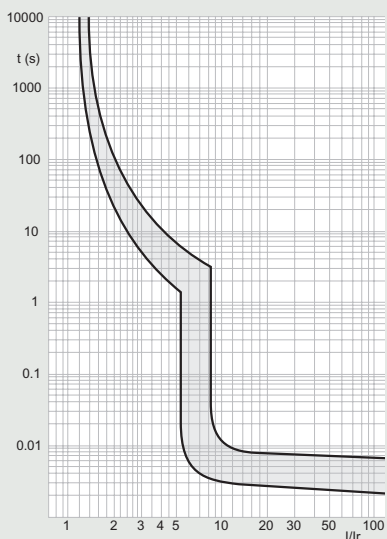

Current limitation curves

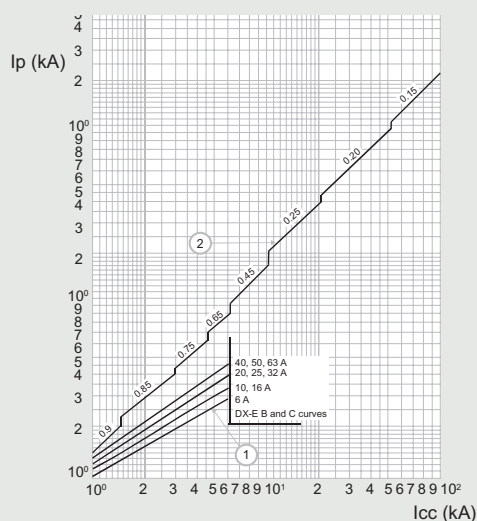

Marking and dimensions

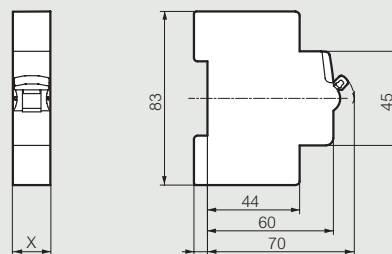
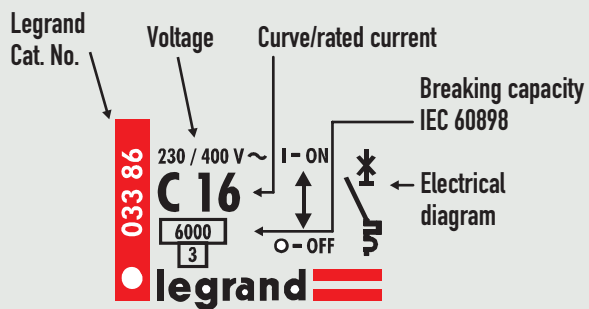

X (mm)	1P	2P	3P	4P
X (mm)	17.7	35.6	53.4	71.2

LR modular circuit breakers

The characteristics of LR modular circuit breakers make them suitable for use in residential installations. The range includes ratings from 6 A to 63 A, with two tripping curves: C (for the entire range) and B (for single pole, 2-pole and 3-pole models only).

The LR range provides minimum functional characteristics for residential installations:

- B and C curves
- Ratings: 6 to 63 A
- 1P, 1P+N, 2P, 3P, 3P+N and 4P
- Breaking capacities (IEC 60898-1):
 - 10 000 A on 127/220 V AC
 - 6 000 A on 230/400 V AC

LR circuit breakers cannot take any accessories, such as control auxiliaries or motor-driven controls.



By design, LR circuit breakers cannot be used in coordination or in combination with other circuit breakers

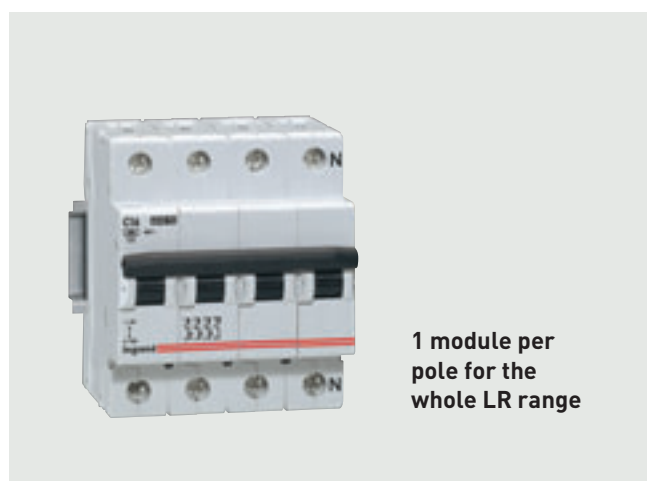

1 module per pole for the whole LR range

Characteristics of LR circuit breakers

Number of poles		1P	1P+N	2P	3P	3P+N	4P	
Rated current (A) at 30°C		6 - 10 - 13 - 16	6 - 10 - 13 - 16	6 - 10 - 13 - 16	6 - 10 - 13 - 16	6 - 10 - 13 - 16	6 - 10 - 16	
Ratings		20 - 25 - 32 40 - 50 - 63	20 - 25 - 32	20 - 25 - 32 40 - 50 - 63	20 - 25 - 32 40 - 50 - 63	20 - 25 - 32 40 - 50 - 63	20 - 25 - 32 40 - 50 - 63	
Types of curve		B and C	C	B and C	B and C	C	C	
Nominal voltage Un (V) with standard tolerances		230/400 V	230 V	400 V	400 V	400 V	400 V	
Nominal frequency		50/60 Hz	50/60 Hz	50/60 Hz	50/60 Hz	50/60 Hz	50/60 Hz	
Maximum operating voltage (50/60Hz) + or - 10%		240/415 V	240 V	415 V	415 V	415 V	415 V	
Breaking capacity Icn (kA) acc. to IEC 60898	127 V/230 V AC	10 kA/6 kA	10 kA/6 kA	15 kA/10 kA	10 kA/10 kA	10 kA/10 kA	10 kA/10 kA	
	400 V AC			6 kA	6 kA	6 kA	6 kA	
Breaking capacity Icu (kA) acc. to IEC 60947-2	127 V/230 V AC	10 kA/6 kA	10 kA/6 kA	15 kA/10 kA	10 kA/10 kA	10 kA/10 kA	10 kA/10 kA	
	400 V AC			6 kA	6 kA	6 kA	6 kA	
Standard breaking capacity Ics (% Icu)	127 V/230 V AC	75%	75%	75%	75%	75%	75%	
	400 V AC			75%	75%	75%	75%	
Rated insulation voltage Ui (V)		500 V	500 V	500 V	500 V	500 V	500 V	
Rated impulse withstand voltage (kV)		4	4	4	4	4	4	
Degree of pollution 2								
	Endurance (mechanical and electrical operating cycles)	No-load	20 000	20 000	20 000	20 000	20 000	20 000
		With load	10 000	10 000	10 000	10 000	10 000	10 000
DC	2000	2000	2000	2000	2000	2000		
Dielectric strength		2500 V	2500 V	2500 V	2500 V	2500 V	2500 V	
Operating temperature		-25°C to +70°C	-25°C to +70°C	-25°C to +70°C	-25°C to +70°C	-25°C to +70°C	-25°C to +70°C	

Performance data

Curve B

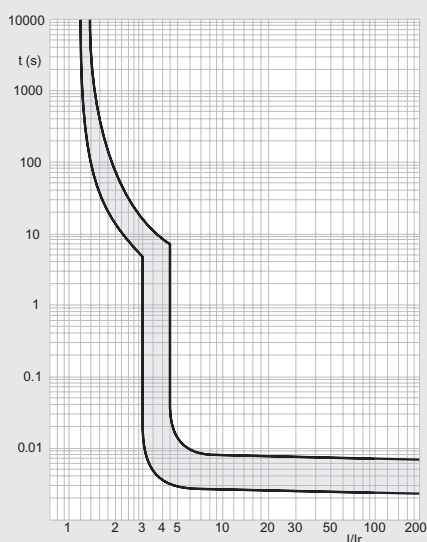

Curve C

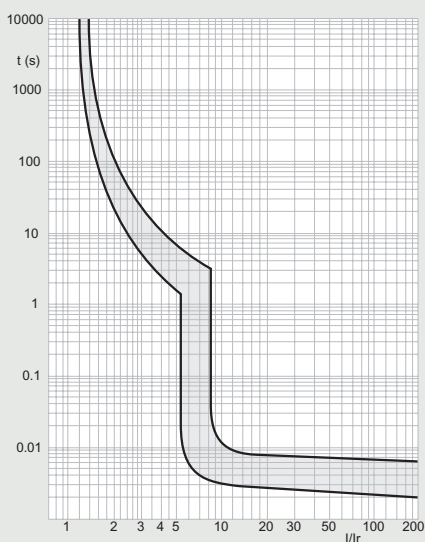

Current limitation curves

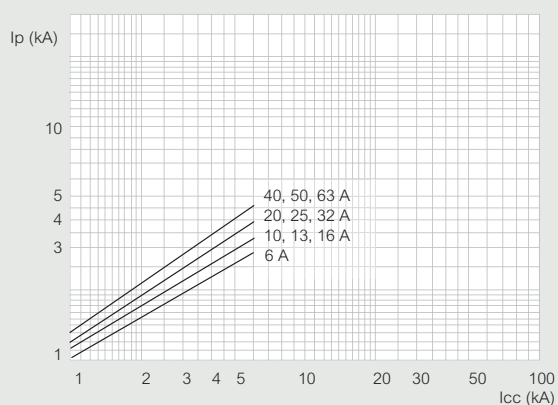

Marking

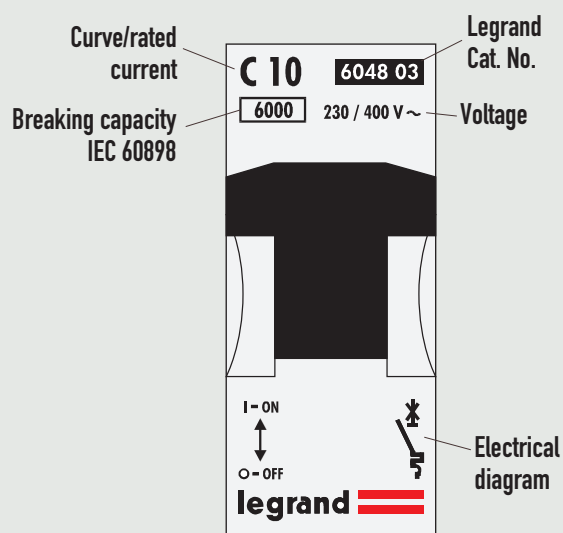

→ Dimensions of LR MCBs: see p. 121

Legrand isolating switches

Legrand isolating switches are used for load breaking and isolation of LV circuits. Designed to separate an installation or part of an installation electrically, the purpose of isolation is to ensure the safety of people working on the installation.

There are 3 categories of device, depending on their characteristics and where they are to be used:

- Isolating switches with positive contact operation
- Isolating switches with visible contact indication
- Trip-free isolating switches

→ Fused isolating switches: see p. 130



Isolation does not on its own ensure that the installation is made safe. Appropriate methods must be used to lock out the installation in order to prevent any unwanted re-energisation (see book 09: "Operating functions").

ISOLATING SWITCHES WITH POSITIVE CONTACT INDICATION

Positive contact indication is checked by reliable linking between the position of the contacts and that of the control switch handle. The indication "I" or "O" (red or green) on the handle thus confirms the actual position of the contacts.

Compliance with standard IEC 60947 is evidence of this.

DX-IS modular isolating switches with positive contact operation are available in 1P, 2P, 3P and 4P versions, up to 125 A.

DX-IS with trip option (2P and 4P, 40 to 125 A) can be used with a current shunt trip or an undervoltage release. All models can take auxiliary contacts Cat. Nos. 073 50/54, which are the same as for circuit breakers.

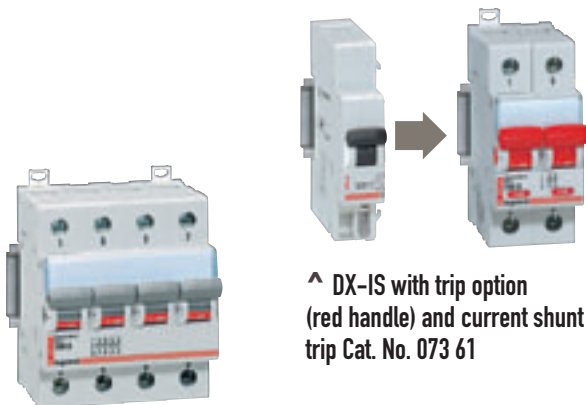

^ DX-IS with trip option (red handle) and current shunt trip Cat. No. 073 61

^ DX-IS isolating switches: 1 module per pole up to 125 A

Characteristics of DX-IS

Ith		16 - 32 A	40 - 63 A	100 - 125 A
Capacity of cage terminals	flexible	1.5 to 16 mm ²	1.5 to 25 mm ²	6 to 35 mm ²
	rigid	1.5 to 16 mm ²	1.5 to 35 mm ²	4 to 50 mm ²
Insulation voltage (Ui)		250 400 V AC	250 400 V AC	250 400 V AC
Impulse withstand voltage (Uimp)		4 kV	4 kV	4 kV
Utilization category		AC 22 A	AC 22 A	AC 22 A
		AC 23 A	AC 23 A	AC 23 A
Short-time withstand current (Icw)		750 A	1700 A	2500 A
Short-circuit making capacity (Icm)		1500 A	3000 A	3700 A
Mechanical endurance (No. of operations)		> 30 000	> 30 000	> 30 000
Protection index		IP 2x wired	IP 2x wired	IP 2x (25 mm ²)



Isolating switches are tested in accordance with standard IEC 60947-3:

- AC 22 A/DC 22 A = combined motor-resistor breaking
- AC 23 A/DC 23 A = motor breaking (inductive loads)
- AC = alternating current/DC = direct current
- A = use with frequent operations

ISOLATING SWITCHES WITH VISIBLE CONTACT INDICATION

The actual position of the contacts can be checked via a display window. Visible contact indication is required by the energy distribution company for subscriber stations with certain tariffs with LV metering (single transformer, power \leq 1250 kVA).

The handle can be black, or red/yellow for emergency control. It can be padlocked in "open" position. The integrated cage terminals take rigid or flexible conductors. They can also take distribution terminals Cat. No. 048 67 (six 35 mm² rigid or 25 mm² flexible outputs) or 12 mm wide copper bars.

1 VISTOP 63 TO 160 A

Vistop devices are available with 3 or 4 poles. They are mounted on a \sqcup rail under a modular faceplate in all XL³ enclosures. Vistop \geq 100 A can also be attached using screws. They are available with right or left side-mounted handles (mounted externally on the side of the enclosure) or front handles (that can be mounted externally on the door using accessory Cat. No. 227 32).

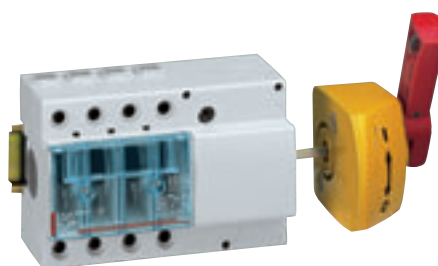

< Vistop with external side-mounted handle for emergency operations

Vistop electrical characteristics

Thermal rating (I _{th})	63 A	100 A	125 A	160 A	16 A ⁽²⁾	
Connection	Cu (flexible)	4 to 35 mm ²	4 to 50 mm ²			6 mm ²
	Cu (rigid)	4 to 50 mm ²	4 to 70 mm ²			6 mm ²
Insulation voltage (U _i)	690 V AC	800 V AC	800 V AC	800 V AC	400 V AC	
Impulse withstand voltage (U _{imp})	8 kV	8 kV	8 kV	8 kV	-	
AC 22 A	400 V	63 A (35 kW)	100 A (55 kW)	125 A (70 kW)	160 A (88 kW)	16 A
	500 V	63 A (44 kW)	100 A (69 kW)	125 A (87 kW)	160 A (110 kW)	-
AC 23 A	690 V	40 A (38 kW)	100 A (96 kW)	125 A (120 kW)	125 A (120 kW)	-
DC 22 A/250 V ⁽¹⁾	63	100	125	125	16	
DC 23 A/250 V ⁽¹⁾	63	100	125	125	10	
Dynamic resistance (k \hat{A} peak)	15	15	15	15	2	
Short-time withstand current kA (I _{cw})	2.5	3.5	3.5	3.5	1	
Permissible I _{sc} with fuses (kA rms)	100	100	100	80	100	
Max. fuse rating	63 A	100 A (gG) 63 A (aM)	125 A (gG) 125 A (aM)	160 A (gG) 125 A (aM)	-	
Short-circuit making capacity (prospective k \hat{A} peak) (I _{cm})	7	12	12	12	1	
Mechanical endurance (No. of operations)	> 30 000	> 30 000	> 30 000	> 30 000	> 30 000	
Protection index	IP 2xB (\geq 6 mm ²) IP 3xC under faceplates	IP 2xB (\geq 10 mm ²) - IP 3xC under faceplates				

(1) Number of poles involved in the breaking operation: 2

(2) Auxiliary isolating switch

Legrand isolating switches (continued)

Dimensions of Vistop

■ Front handle

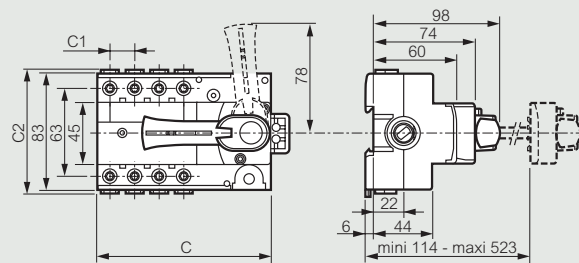

■ Lateral handle

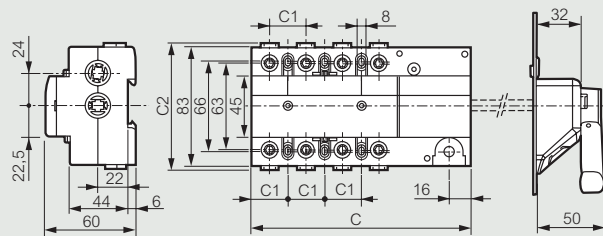

	Front handle			External lateral handle		
	63 A 3P et 4P	100 à 160 A 3P	160 A 4P	63 A 3P et 4P	100 à 160 A 3P	160 A 4P
C	125	133	160	125	133	160
C₁	17,7	26,7		17,7	26,7	
C₂	90	91		90	91	

2 DPX-IS 63 TO 1600 A

DPX-IS isolating switches provide visible contact indication from 63 to 1600 A, with 3 poles and 4 poles. They are fixed on special plates or on a \perp rail (under a modular faceplate with window) up to 250 A. They are available with a front, or right or left side-mounted handle, which can be remotely mounted on the outside of the enclosure. The operating handle can be padlocked in "open" position. The standard handle (black) can be replaced by a handle for emergency operation (red/yellow).

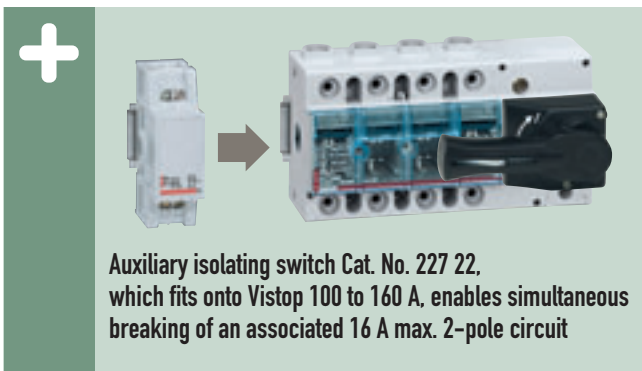
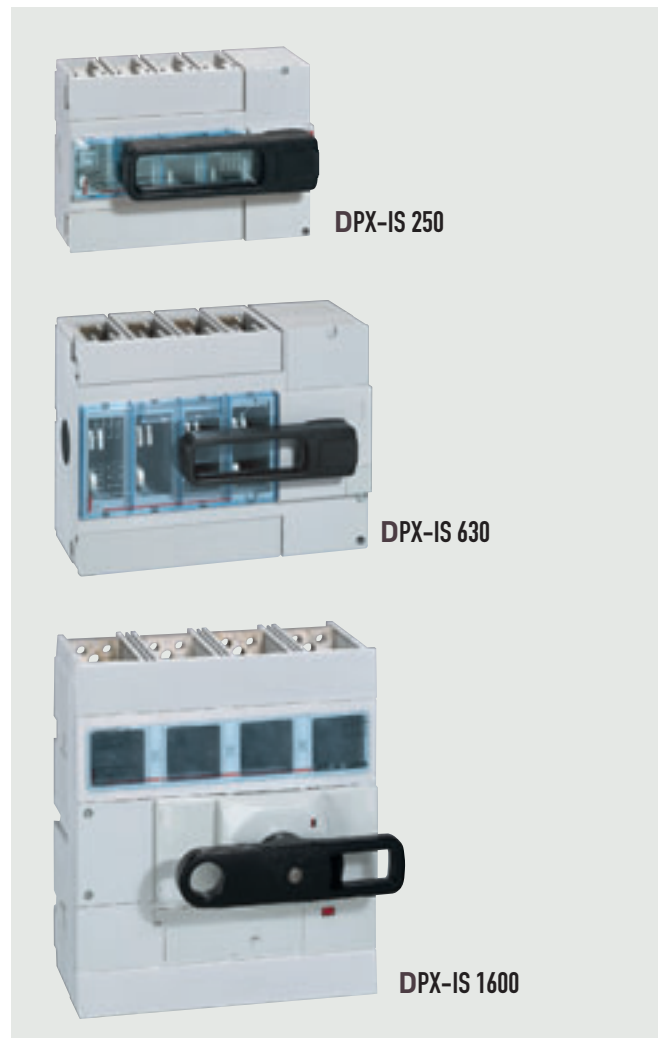

Auxiliary isolating switch Cat. No. 227 22, which fits onto Vistop 100 to 160 A, enables simultaneous breaking of an associated 16 A max. 2-pole circuit

Electrical characteristics of DPX-IS

Current		DPX-IS 250				DPX-IS 630		DPX-IS 1600			
		63 A	100 A	160 A	250 A	400 A	630 A	800 A	1000 A	1250 A	1600 A
Connection	Cu (flexible)	150 mm ²				1 x 240 or 2 x 185 mm ²		2 x 185 mm ² or 4 x 185 mm ²			
	Cu (rigid)/Alumin.	185 mm ²				1 x 300 or 2 x 240 mm ²		2 x 240 mm ² or 4 x 240 mm ²			
Copper bar or lug		Max. width 28 mm				Max. width 32 mm		Max. width 50 mm or 80 mm			
Nominal voltage (Ue)		690 V AC				690 V AC		690 V AC			
Insulation voltage (Ui)		800 V AC				800 V AC		690 V AC			
Impulse withstand voltage (Uimp)		8 kVA				8 kVA		8 kVA			
AC 23 A	400 V AC	63 A	100 A	160 A	250 A	400 A	630 A	800 A	1000 A	1250 A	1600 A
	500 V AC					400 A	630 A	800 A	1000 A	1250 A	1600 A
	690 V AC	63 A	100 A	160 A	160 A	400 A	400 A	800 A	1000 A	1250 A	1600 A
AC 22 A	690 V AC	63 A	100 A	160 A	250 A	400 A					
DC 23 A	250 V DC							800 A	1000 A	1250 A	1600 A
Short-time withstand current (Icw)		12 kA rms				20 kA rms		20 kA rms			
Permissible current with fuse (Isc)		100 kA rms				100 kA rms		100 kA rms			
Max. rating, gG fuse		63 A	100 A	160 A	250 A	400 A	630 A	800 A	1000 A	1250 A	1600 A
Max. rating, aM fuse		63 A	100 A	160 A	160 A	400 A	630 A	800 A	1000 A	1250 A	1600 A
Short-circuit making capacity (Icm) (prospective kA peak)		40 kA				40 kA		40 kA			
Endurance	mechanical	25 000 operations				15 000 operations		10 000 operations			
	electrical (AC 23 400 V)	2500 operations				1500 operations		3000 operations		2000 operations	
Protection index		IP 20 on front panel				IP 20 on front panel		IP 20 on front panel			



The versions with trip can be fitted with the same control auxiliaries as DPX circuit breakers (see p. 63).

Legrand isolating switches (continued)

Dimensions of DPX-IS 250

■ Front handle

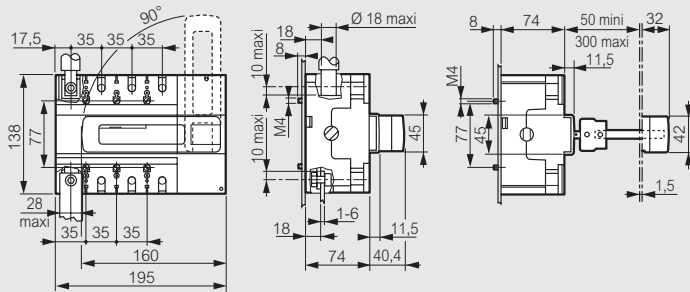

■ Mounted on rail

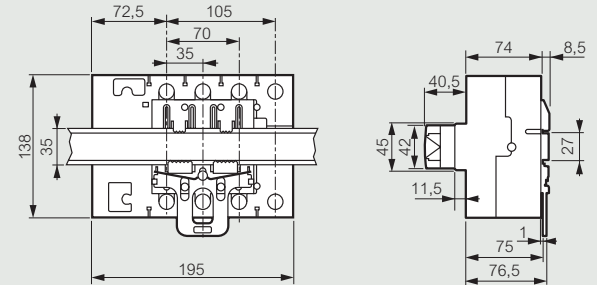

■ Right lateral handle

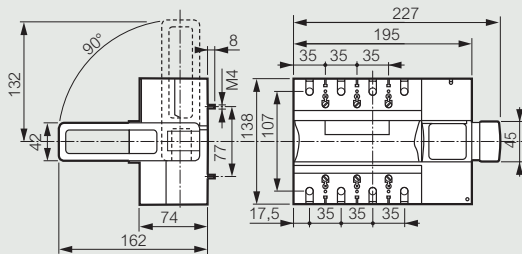

■ With terminal shields

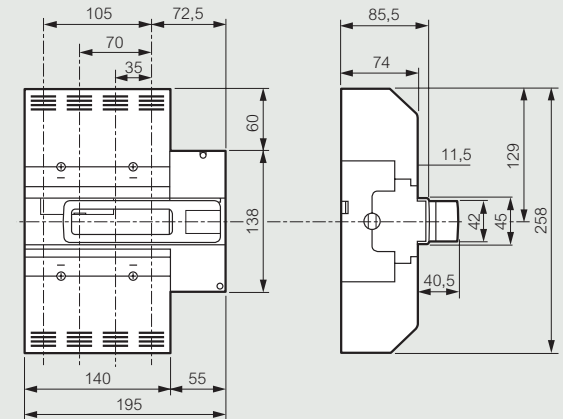

■ Left lateral handle

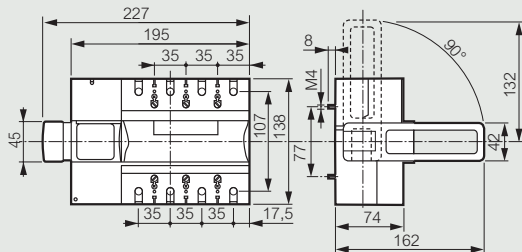

Dimensions of DPX-IS 630

■ Front handle

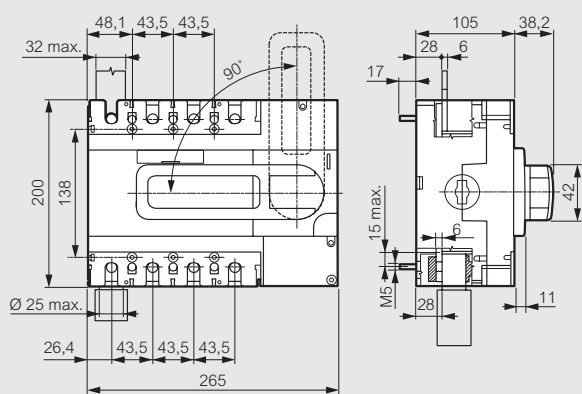

■ With terminal shields

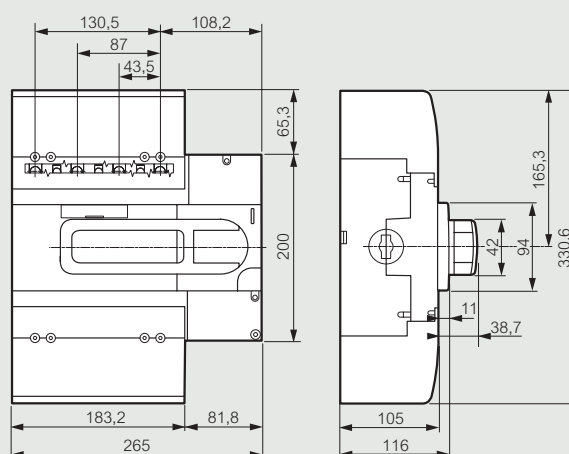

■ Right lateral handle

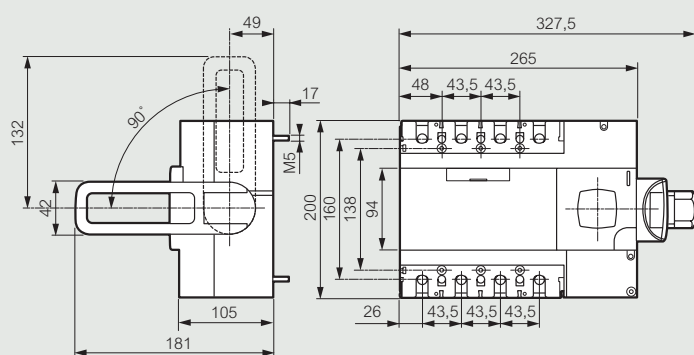

■ Left lateral handle

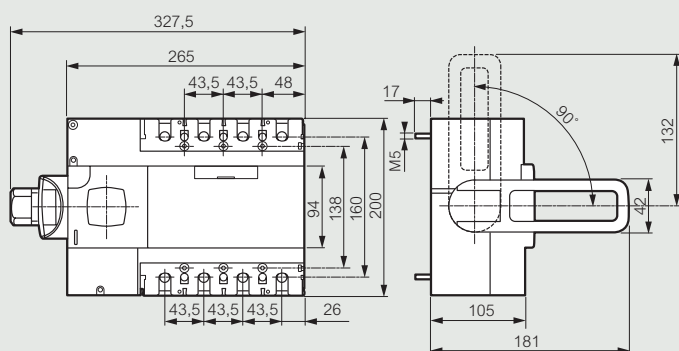

Legrand isolating switches (continued)

Dimensions of DPX-IS 1600

■ 3P

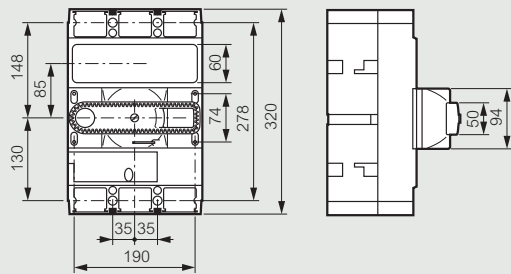

Without handle extension

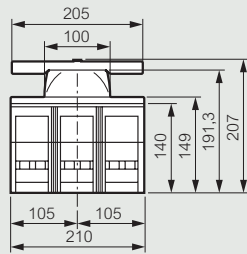

With handle extension

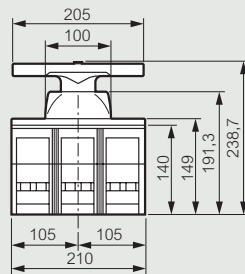

■ 4P

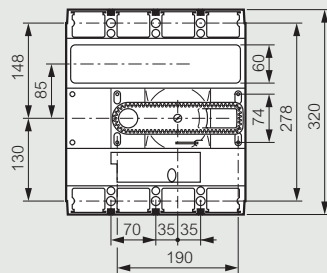

Without handle extension

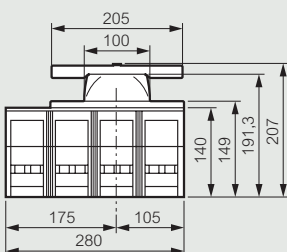

With handle extension

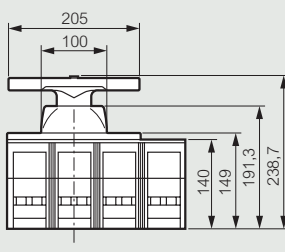

■ Vari-depth handle

IP 40

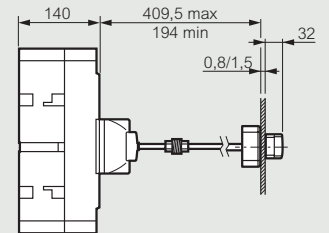
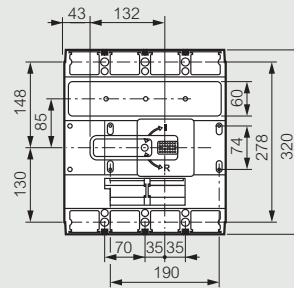

■ Vari-depth handle

IP 55

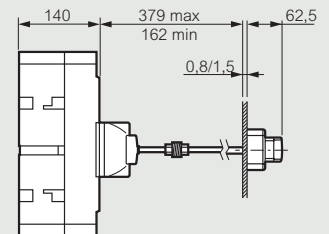
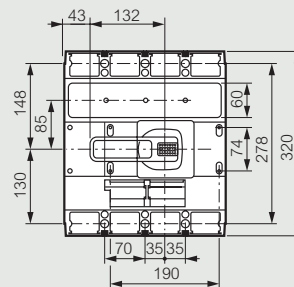

TRIP-FREE ISOLATING SWITCHES

DMX³-I and DPX-I switches have the same mounting methods and the same locking and connection options as DMX³ and DPX circuit breakers. (see p. 54 and 12). The motor-driven controls and electrical auxiliaries are also the same as those for the circuit breakers.

Circuit opening, closing and monitoring can therefore be carried out remotely.

→ DMX³-I dimensions: see p. 34-43
DPX-I dimensions: see p. 76-89

Electrical characteristics of DMX³-I

	DMX ³ -I 2 500				DMX ³ -I 4 000	
	1 250 A	1 600 A	2 000 A	2 500 A	3 200 A	4 000 A
Number of poles	3P - 4P	3P - 4P	3P - 4P	3P - 4P	3P - 4P	3P - 4P
Rating I _n (A)	1250	1600	2000	2500	3200	4000
Rated insulation voltage U _i (V)	1000	1000	1000	1000	1000	1000
Rated impulse withstand voltage U _{imp} (kV)	12	12	12	12	12	12
Rated operational voltage (50/60 Hz) (kV)	690	690	690	690	690	690
Short-circuit making capacity I _{cm} (kA)	230 V AC	105	105	105	105	105
	415 V AC	105	105	105	105	105
	500 V AC	105	105	105	105	105
	600 V AC	88	88	88	88	88
	690 V AC	63	63	63	63	63
Short time withstand current I _{cw} (kA) for t = 1s	230 V AC	50	50	50	50	50
	415 V AC	50	50	50	50	50
	500 V AC	50	50	50	50	50
	600 V AC	42	42	42	42	42
	690 V AC	36	36	36	36	36
Endurance (cycles)	mechanical	10 000	10 000	10 000	10 000	10 000
	electrical	5000	5000	5000	5000	5000

Electrical characteristics of DPX-I

		DPX-I 125	DPX-I 160	DPX-I 250 ER	DPX-I 250	DPX-I 630	DPX-I 1 600
Operating voltage (U _e)	50/60 Hz	500	500	500	690	690	690
	DC	250	250	250	250	250	250
Insulation voltage U _i (V AC)		500	500	500	690	690	690
Rated impulse withstand voltage U _{imp} (kV)		6	6	6	8	8	8
Short-circuit making capacity at 400 V I _{cm} (kA)		3	3.6	4.3	4.3	40	40
Short-time withstand current I _{cw} 1 s (kA)		1.7	2.1	3	3	20	20
Endurance (cycles)	mechanical	8500	7000	7000	7000	4000	2500
	electrical	1500	1000	1000	1000	1000	500
Conventional thermal current (A)		125	160	250	250	630	1600
Rated operating current (A)	AC 23 A (690 V AC)	125 (500 V)	160 (500 V)	250 (500 V)	250	630	1600
	DC 23 A (250 V DC)	125	160	250	250	630	-

Fuses

Fuses were the first type of protection to be used, and they still have a place in numerous applications. Although they do not have the flexibility of adjustment and resetting capacity of a circuit breaker, they are nevertheless reliable, high performance devices in terms of their ability to break very high short-circuit currents.



FUSE TECHNOLOGY

The fuse cartridge is inserted in the circuit to be protected. If there is an overcurrent, the circuit is broken automatically by fusing of the conductive fuse element, which is specially rated, inside the cartridge. The silica in the body of the cartridge absorbs very high energies by fusing and vitrification. Unlike a circuit breaker, the fuse cartridge is destroyed by the fault and must be replaced. Fuse cartridges comply with standard IEC 60269-1.

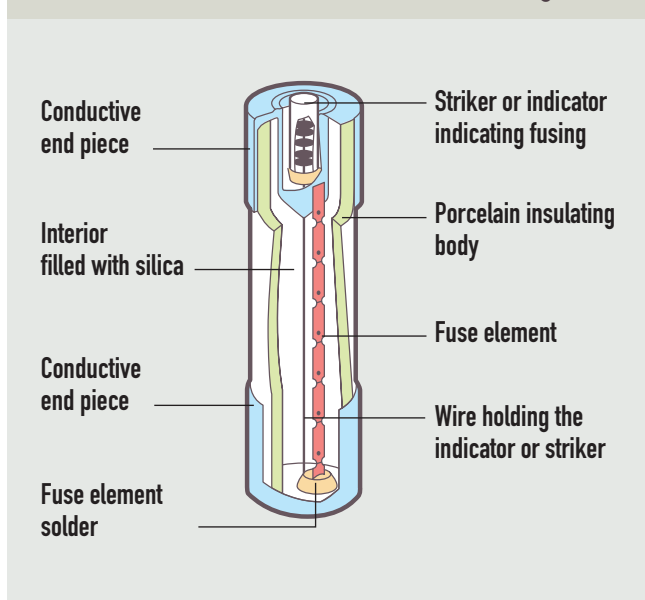
Internal structure of a fuse cartridge



Standard fuse cartridges

Cartridge	Size	Standard rating range
 Cylindrical	8 x 32	1 - 16 A
	10 x 38	0.5 - 25 A
	14 x 51	2 - 50 A
	22 x 58	4 - 125 A
 Blade type	00	25 - 160 A
	0	63 - 200 A
	1	125 - 250 A
	2	200 - 400 A
	3	500 - 630 A
	4	630 - 1250 A

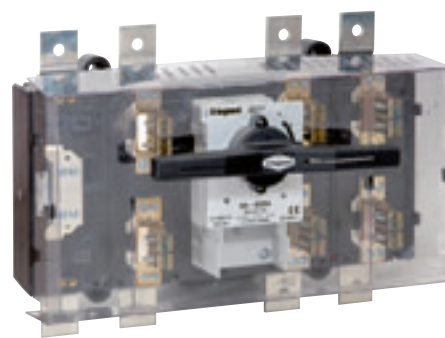

^ SPX-D isolating switch for blade type cartridges

They come in various shapes and sizes. In low voltage electrical installations cylindrical cartridges and blade type cartridges are mainly used, with ratings ranging from 0.5 A to 1250 A. Fuse cartridges are fitted in isolating switches, fuse carriers or simply on bases.



< SP fuse carrier for cylindrical cartridges

Base for > blade type fuses

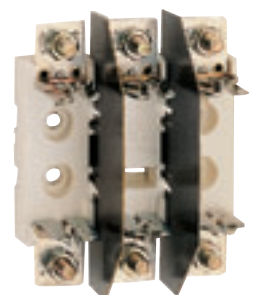



Fuses with indicators and striker fuses

Fuse cartridges with indicator or striker make it possible to identify the cartridges to be replaced.

- Fuses with indicator: a disk on the end of the cartridge indicates the state of the fuse.
- Striker fuses: when fusing occurs, a striker activates a microswitch in the fuse carrier, and the state of the fuse is shown on an indicator light.

The operating principle is more or less the same for both systems.

The spring of the indicator or striker is held in the “set” position by a wire made of low conductivity material. When a fault triggers fusing of the cartridge, there is a recovery voltage between the two ends of the wire. It then melts and the indicator or striker, which is therefore released, is pushed in by the action of the spring.

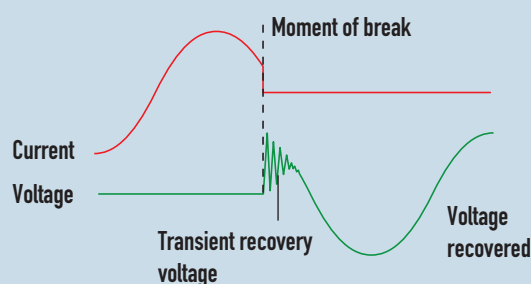

Fuses in the standards

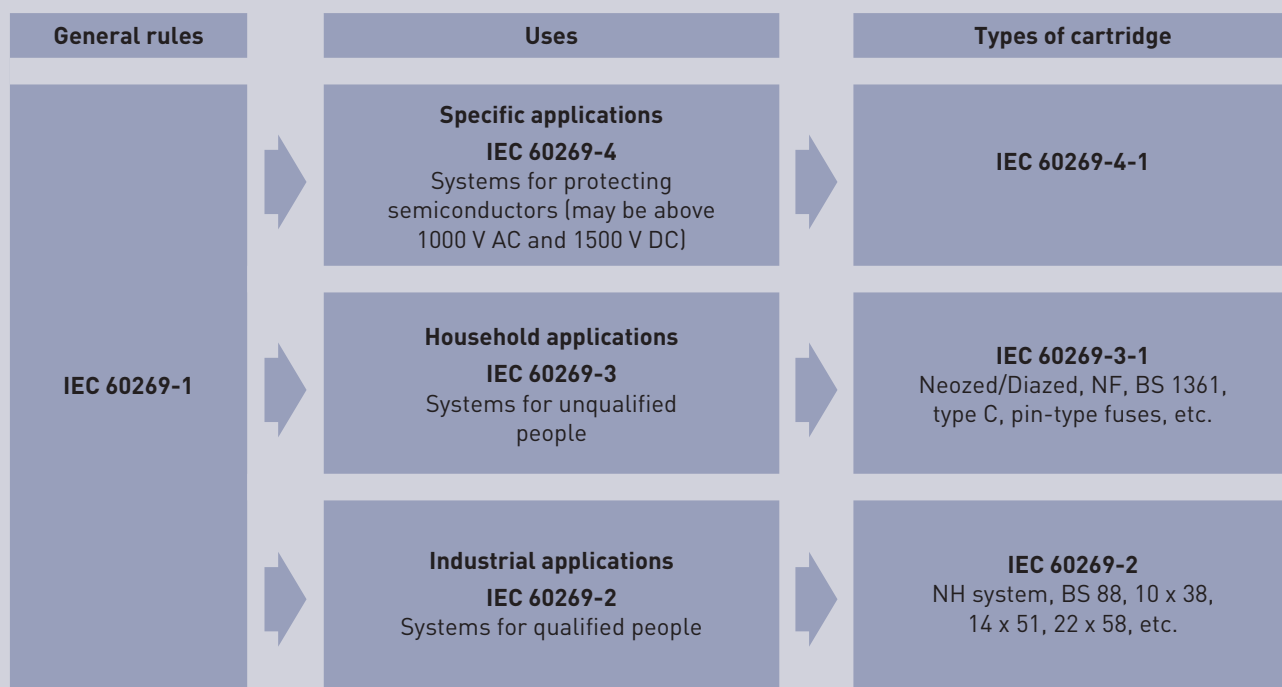

Fuses (continued)

FUSE CHARACTERISTICS

1 TYPES OF FUSE

Fuses are identified by 2 letters, according to their application category. In low voltage installations gG and aM fuses are mainly used.

- **gG cartridges** (general use) protect the circuits against low and high overloads and, of course, against short circuits. gG cartridges are marked in black.

- **aM cartridges** (for use with motors) protect against high overloads and short circuits. They are calculated to resist certain temporary overloads (starting a motor). These cartridges must therefore be used together with a thermal protection device to protect against low overloads. aM cartridges are marked in green.

2 RATED CURRENTS AND VOLTAGES

The rated current can cross a fuse indefinitely, without triggering either fusing or any excessive temperature rise. The rated voltage is the voltage at which this fuse can be used.

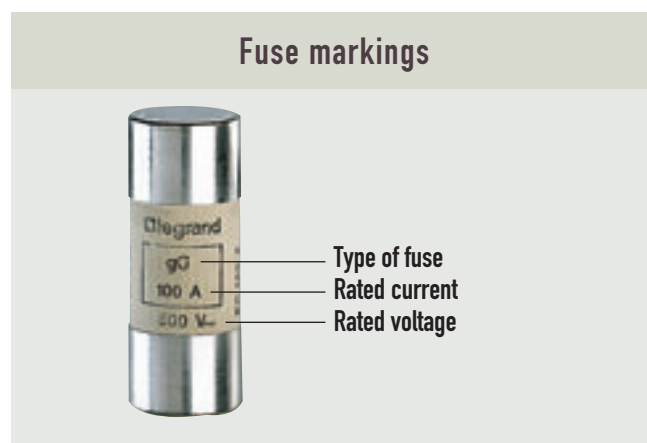

Meanings of the letters used for the application categories

The first letter indicates the main operation:

a = associated

The fuse must be associated with another protection device, because it cannot break faults below a specified level. It provides short-circuit protection only.

g = general

It breaks all faults between the lowest fusing current (even if it takes 1 hour to melt the fuse elements) and the breaking capacity. It provides short-circuit and overload protection.

The second letter indicates the category of equipment to be protected:

G = Protection of cables and conductors

M = Protection of motor circuits

R = Protection of semiconductors

S = Protection of semiconductors

Tr = Protection of transformers

N = Protection of conductors according to North American standards

D = Time-delay fuse for protecting motor circuits according to North American standards

3 CONVENTIONAL NON-FUSING AND FUSING CURRENTS

Conventional non-fusing current (I_{nf})

This is the current value that the fuse cartridge can withstand for a conventional time without melting.

Conventional fusing current (I_f)

This is the current value that causes the fuse cartridge to fuse before the conventional time has elapsed.

Ratings (A)	I_{nf} Non-fusing current	I_f Fusing current	t Conventional time
$I_n \leq 4$	$1.5 I_n$	$2.1 I_n$	1 h
$4 < I_n \leq 10$	$1.5 I_n$	$1.9 I_n$	1 h
$10 < I_n \leq 25$	$1.4 I_n$	$1.75 I_n$	1 h
$25 < I_n \leq 63$	$1.3 I_n$	$1.6 I_n$	1 h
$63 < I_n \leq 100$	$1.3 I_n$	$1.6 I_n$	2 h
$100 < I_n \leq 160$	$1.2 I_n$	$1.6 I_n$	2 h
$160 < I_n \leq 400$	$1.2 I_n$	$1.6 I_n$	3 h
$400 < I_n$	$1.2 I_n$	$1.6 I_n$	4 h

4 OPERATING ZONE

The operating zone defined by the standards is used to determine the operating time of the fuse according to the current crossing it. It is important to know the operating characteristics of the fuse in order to calculate the discrimination of the various protective devices installed in series.

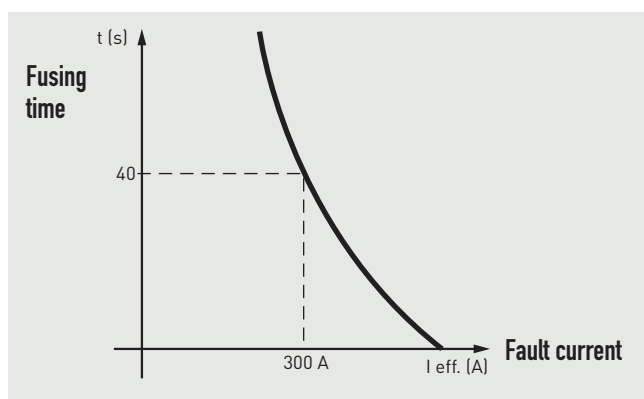

For a 100 A 22 x 58 gG cartridge, an overload of 300 A will melt the cartridge in 40 s

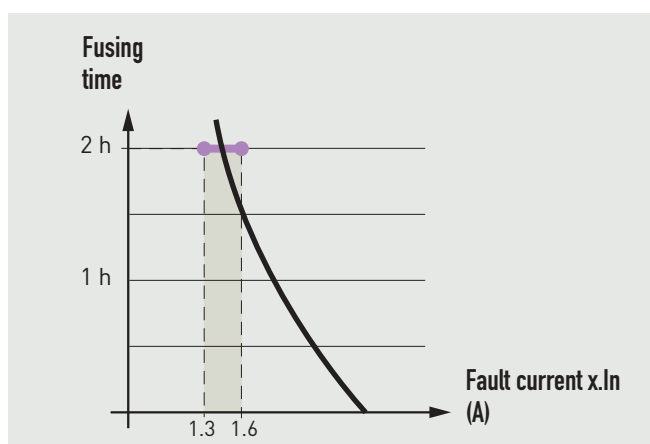

In the above example (100 A gG cartridge):

Conventional time = 2 h

$I_{nf} = 1.3$

$I_f = 1.6 I_n$

5 BREAKING CAPACITY

The breaking capacity must be at least equal to the prospective short-circuit current that may occur at the point at which the fuse is installed. The higher the breaking capacity, the more capable the fuse of protecting the installation against high intensity short circuits. HBC (High Breaking Capacity) fuses limit short circuits that could reach more than 100 000 A rms.

Fuses (continued)

6 LIMITATION CURVE

The limitation of the current can vary according to the conditions of the short circuit (intensity, $\cos \varphi$, short-circuit starting angle ψ). The limitation curves of Legrand cartridges represent the maximum limited current values that can be achieved under the most unfavourable conditions.

Example

For a prospective short circuit of 10 000 A rms (or 10 kA rms) in view of the maximum asymmetry of the current, the short circuit could reach a theoretical maximum value of $2.5 \times I$ rms, i.e. 25 kA peak.

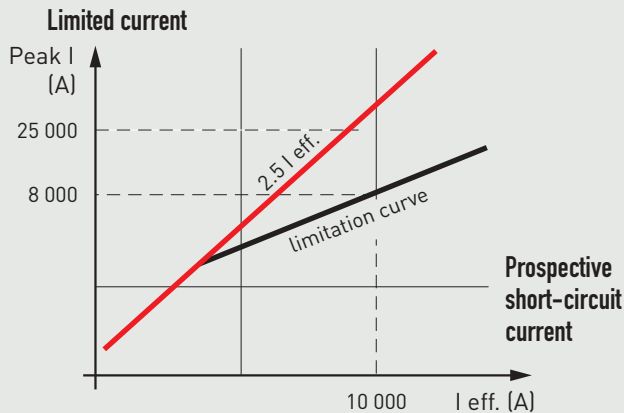

The 100 A gG cylindrical fuse cartridge limits the first current wave to 8 000 A peak, i.e. approximately 30% of the prospective maximum value. The destructive electrodynamic effects are therefore reduced by a factor of $10 \left(\frac{8000}{25000} \right)^2$ of the maximum value.

The higher the prospective short-circuit current, the higher the limitation ratio.

For example for a 100 000 A rms short circuit, i.e. 250 000 A peak, the 100 A gG cartridge limits this current to 15 000 A peak, i.e. limitation to 6% of the prospective maximum current and limitation to 0.36% of the prospective maximum electrodynamic effects.



Importance of the limitation capacity

A short circuit is dangerous, both in terms of its electrodynamic effects and its thermal effects:

- The destructive electrodynamic effects depend on the square of the peak current reached during the short circuit, and cause mechanical damage to the insulation of the conductors.
 - The destructive thermal effects depend on the thermal energy dissipated during the short circuit, and could burn the insulation of the conductors.
- Fuse cartridges limit both these effects as much as possible.

7 LIMITED THERMAL STRESS

A short circuit triggers the release of a considerable amount of energy. The fuse cartridge limits this energy to a much lower value, conventionally known as the limited thermal stress, expressed in A²s.



Why must the thermal stress be limited?

If the energy released by the short circuit is not limited, it can quickly lead to total or partial destruction of the installation.

Thermal stress is governed by two main parameters:

- $\cos \varphi$: the lower this is, the greater the energy
- Voltage: the higher the voltage, the greater the energy

Fuse cartridges significantly limit this energy. For example, for a 10 kA rms asymmetrical short circuit at 230 V, $\cos \varphi = 0.1$, would develop if there were no cartridge, on several current waves. For the first wave only, the thermal stress could reach 4 000 000 A²s.

Under the same fault conditions, a 100 A gG Legrand cartridge would limit the thermal stress to 78 000 A²s, i.e. 1.95% of the value on the first wave of the prospective current only.



Difference between pre-arcing and arcing thermal stresses

A fuse breaks a short circuit in two stages: pre-arcing, then arcing.

- The pre-arcing thermal stress corresponds to the minimum energy necessary for the fuse element of the cartridge to start melting. It is important to know this thermal stress in order to determine the selectivity on a short circuit between several protection systems in series.
- The arcing thermal stress corresponds to the energy limited between the end of pre-arcing and total breaking.

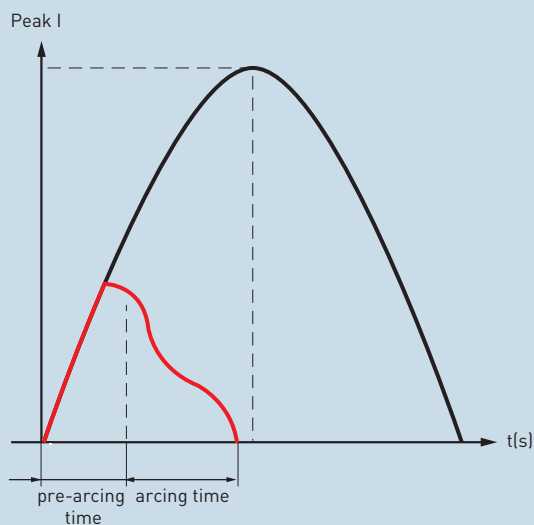

The sum of the arcing and pre-arcing thermal stresses gives the total thermal stress.

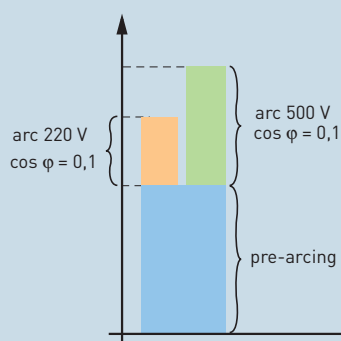

8 SELECTIVITY

A current generally crosses a number of protection devices in series. These devices are calculated and distributed according to the various circuits to be protected.

There is selectivity when only the device protecting the faulty circuit operates (see p. 144).

Example

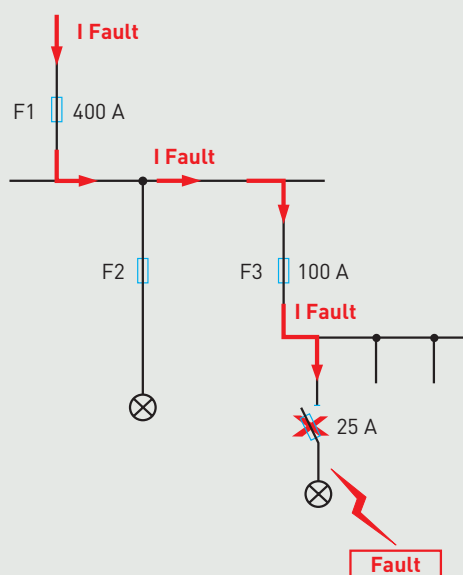

Only the 25 A cartridge has operated on a fault occurring on the line it is protecting. If the 100 A cartridge, or even the 400 A cartridge, had also operated (incorrect selectivity), the whole installation would have gone down.

Fuses (continued)

Cylindrical cartridge fuses gG and aM types

■ Rupture capacity curves
gG type

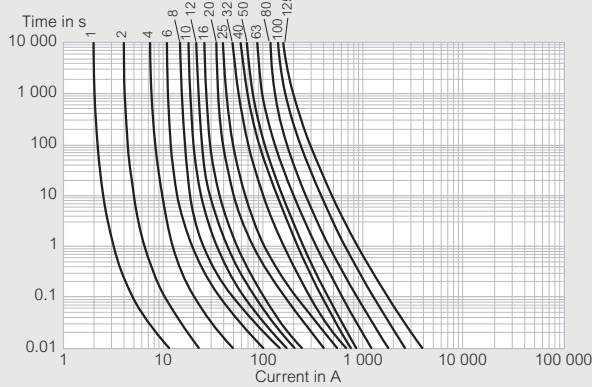

aM type

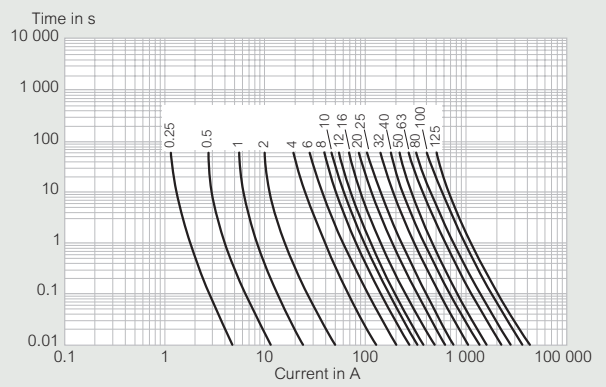

■ Thermal stress ($\int i^2 dt$)
gG type (for 500 V AC)

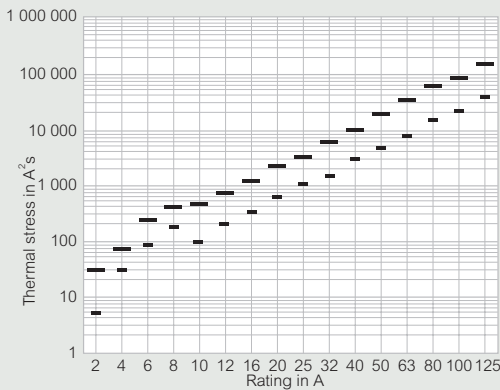

aM type (for 500 V AC except 1250 A for 400 V AC)

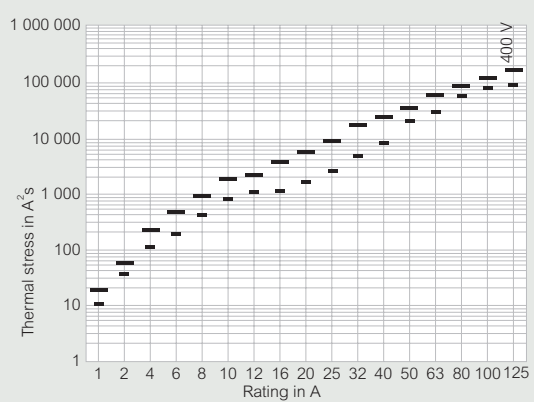

■ Limitation curves
gG type

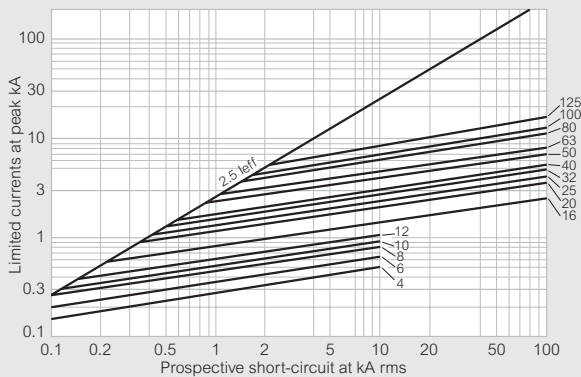

aM type

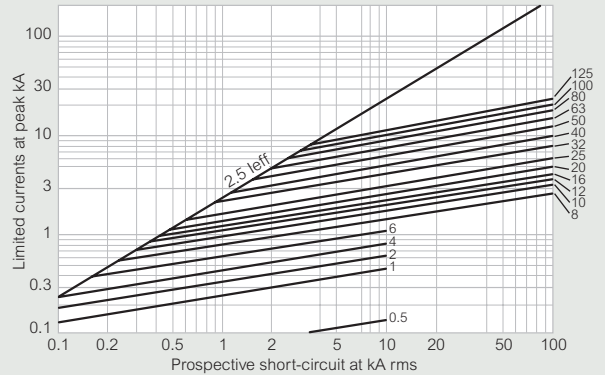

Blade cartridge fuses gG and aM types

Rupture capacity curves

gG type

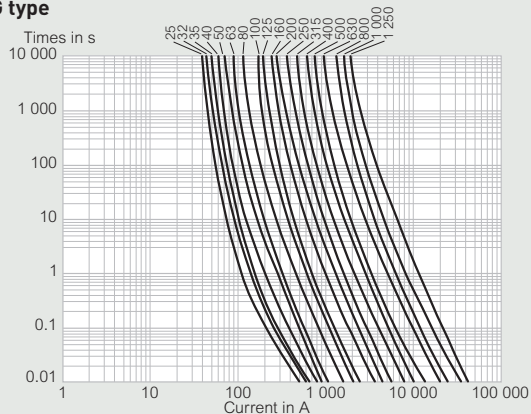

aM type

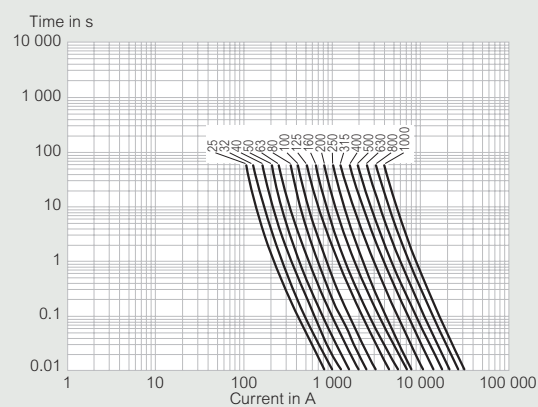

Thermal stress ($\int i^2 dt$) gG type (for 500 V AC)

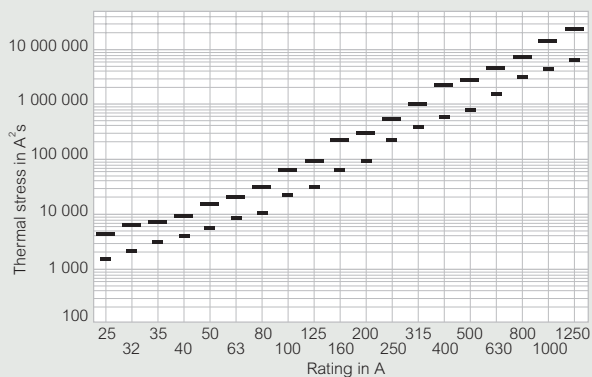

aM type (for 500 V AC except 1250 A for 400 V AC)

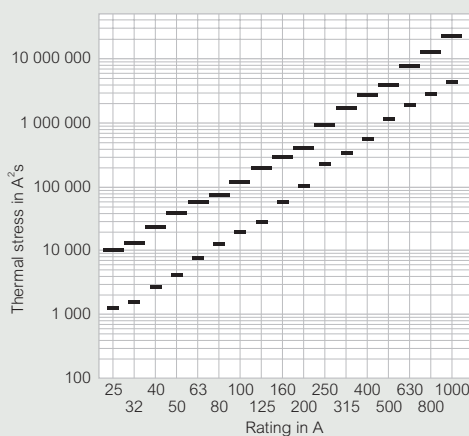

Limitation curves gG type

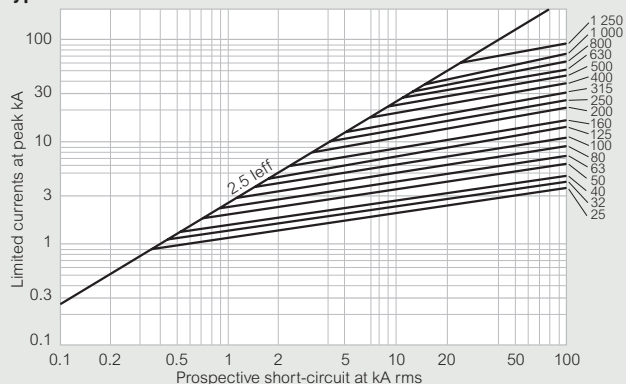

SPX fuse carriers and fused isolating switches

Devices that incorporate fuses (isolating switches, fuse carriers, etc.) are efficient protection methods which are used according to local work practices. However it is important to have a good knowledge of their functional limits: difficulty of selectivity, no accessories, etc.

SPX RANGE

All the devices in the SPX range comply with standard IEC 60947-3. They take blade type fuse cartridges to protect three-phase circuits against overloads and short circuits.

In SPX devices, the fuse cartridges are placed side by side.

In SPX-V devices, the fuse cartridges are placed one below the other.

Common characteristics:

- 3 protected poles
- Safe handling while energised
- Protection against accidental contact
- Fuse can be checked through transparent window
- Voltage control via small opening in window
- Sealable cover
- Simultaneous switching on all poles
- 1600 mechanical operations
- Cover position indicated by auxiliary contact (accessory)
- Screw connection for lug
- Interchangeable connection accessories

SPX-D devices are designed to break loaded circuits. They are available in a 3-pole version and a 3-pole + neutral (unprotected) version. They can be fitted with a direct or remotely mounted operating handle.

- Double-break contacts with positive forced opening and closing

- Category of use AC 23 A

Interlocking:

- Fuse cover in ON position
- Door/panel in ON position

Padlocking:

- Handles in OFF position (up to 3 padlocks)

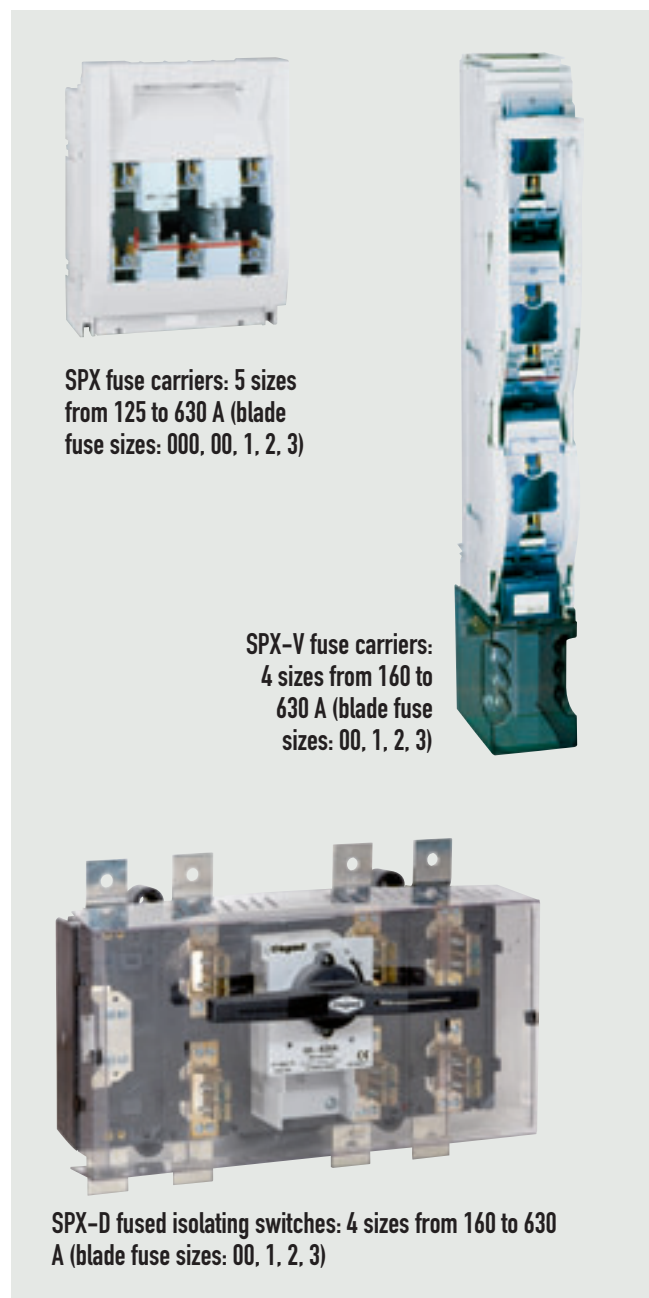

SPX fuse carriers: 5 sizes from 125 to 630 A (blade fuse sizes: 000, 00, 1, 2, 3)

SPX-V fuse carriers: 4 sizes from 160 to 630 A (blade fuse sizes: 00, 1, 2, 3)

SPX-D fused isolating switches: 4 sizes from 160 to 630 A (blade fuse sizes: 00, 1, 2, 3)

TECHNICAL CHARACTERISTICS

	SPX 000	SPX 00	SPX 1	SPX 2	SPX 3
Size	000	00	1	2	3
Nominal current I _n	125 A	160 A	250 A	400 A	630 A
Type of current	AC (50-60 Hz) DC	AC (50-60 Hz) DC	AC (50-60 Hz) DC	AC (50-60 Hz) DC	AC (50-60 Hz) DC
Nominal voltage U _n	690 V AC 250 V DC	690 V AC 250 V DC	690 V AC 440 V DC	690 V AC 440 V DC	690 V AC 440 V DC
Rated insulating voltage U _e	800 V	800 V	800 V	800 V	800 V
Rated impulse withstand voltage U _{imp}	6 kV	6 kV	6 kV	6 kV	6 kV
Category of use EN 60947-3	400 V AC	AC 23 B	AC 23 B	AC 23 B	AC 23 B
	500 V AC	AC 22 B	AC 22 B, AC 23 B (125 A)	AC 23 B	AC 23 B
	690 V AC	AC 21 B	AC 22 B	AC 23 B	AC 23 B
	220 V DC	DC 21 B; DC 22 B (100 A)	DC 22 B (160 A)	DC 22B	DC 22B
	440 V DC	DC 21 B (80 A); DC 22 B (63 A)	DC 21 B (160 A); DC 22 B (125 A)	DC 22B	DC 22B
Conditional rated short-circuit current (with gG/gL fuses)	50 kA (peak 105 kA)	50 kA (peak 105 kA)	50 kA (peak 105 kA)	50 kA (peak 105 kA)	50 kA (peak 105 kA)
Power dissipated per pole, with blade type fuse carrier ⁽¹⁾	9 W	12 W	23 W	34 W	48 W

	SPX-V 00 60 mm	SPX-V 00 100 mm	SPX-V 1	SPX-V 2	SPX-V 3
Size	00	00	1	2	3
Nominal current I _n	160 A	160 A	250 A	400 A	630 A
Type of current	AC (50-60 Hz)	AC (50-60 Hz)	AC (50-60 Hz)	AC (50-60 Hz)	AC (50-60 Hz)
Nominal voltage U _n	690 V AC	690 V AC	690 V AC	690 V AC	690 V AC
Rated insulating voltage U _e	800 V	800 V	1000 V	1000 V	1000 V
Rated impulse withstand voltage U _{imp}	6 kV	6 kV	12 kV	12 kV	12 kV
Category of use EN 60947-3	400 V	AC 23 B	AC 23 B		
	500 V	AC 23 B (120 A)	AC 23 B (125 A)	AC 23 B	AC 23 B
	690 V	AC 22 B	AC 22 B	AC 22 B	AC 22 B
Conditional rated short-circuit current (with gG/gL fuses)	50 kA (peak 105 kA)	50 kA (peak 105 kA)	100 kA (peak 220 kA)	100 kA (peak 220 kA)	100 kA (peak 220 kA)
Power dissipated per pole, with blade type fuse carrier ⁽¹⁾	12 W	12 W	23 W	34 W	48 W

(1) Fuse carrier nominal current according to standard DIN 43620

SPX fuse carriers and fused isolating switches (continued)

SPX-D		160 A	250 A	400 A	630 A	
Fuses NH		Size 00	Size 1	Size 2	Size 3	
Mounting on		DIN Rail/Plate	Plate	Plate	Plate	
Rated insulation voltage U_i (V)		800	1000	1000	1000	
Rated dielectric strength 50 Hz 1 min (V)		6000	8000	8000	8000	
Rated impulse withstand voltage U_{imp} (kV)		8	12	12	12	
Rated thermal current I_{th} (40 °C) (A)		160	250	400	630	
Rated thermal current in enclosure I_{the} (A)		160	250	400	630	
Power dissipation with cartridge fuses⁽¹⁾ (W)		13.5	18.7	30	48	
AC rated operational current I_e (A) (Rated frequency 50/60 Hz)	400 V	AC21A	160	250	400	630
	400 V	AC22A	160	250	400	630
	400 V	AC23A	160	250	400	630
	500 V	AC21A	160	250	400	630
	500 V	AC22A	160	250	400	630
	500 V	AC23A	160	250	400	630
	690 V	AC21A	160	250	400	630
	690 V	AC22A	160	250	400	630
	690 V	AC23A	125	200	315	400
	800 V	AC20A	160	250	400	630
1000 V	AC20A	-	250	400	630	
AC rated operational power P_e (kW)	3 x 400 V	AC23A	90	132	220	355
	3 x 500 V	AC23A	110	160	250	370
	3 x 690 V	AC23A	110	160	250	370
Rated capacitor power (kVAr)	400 V		60	115	200	250
Rated breaking capacity (A)	400 V; $\cos \varphi=0.35$ to 0.45		1280	2000	3200	5100
Rated making capacity (A)	400 V; $\cos \varphi=0.45$		1600	2500	4000	6300
Short-circuit withstand current (rms value)⁽²⁾ (kA rms)			100	100	100	100
Short-circuit making current (rms value)⁽²⁾ (kA rms)			100	100	100	100
Maximum cut-off current (peak value) (kA)			26.3	43.3	43.3	60.8
Maximum power dissipation I^2t (A²s x 10)			478	1600	1600	4600
Minimum number of mechanical operations (cycles)			10000	10000	10000	5000
Minimum number of electrical operations 400 V-AC23 (cycles)			1000	1000	1000	1000
Maximum weight (3/4 poles) (kg)			3.1/4	6.6/8	6.6/8	13/15

(1) Power dissipation values of cartridge fuses used in type test

(2) With a protective device limiting the cut-off current and the joule integral to the indicated values

CONNECTION CAPACITY

There are 3 possible connection methods for SPX and SPX-V:

- plate/lug
- flat connection terminals (accessory)
- prism connection terminals (accessory)



Cage terminal



Extension connector with 3 inputs



Prism terminal



Flat terminal for flat bars

		SPX 000	SPX 00	SPX 1	SPX 2	SPX 3
Lug mounting	Connection	-	M 8	M 10	M 10	M 12
	Tensile strength	-	12-14 Nm	30-35 Nm	30-35 Nm	35-40 Nm
Flat fixing for flexible copper rail, for flexible or rigid copper and multi-core cables	Connection	-	1.5-70 mm ²	70-150 mm ²	120-240 mm ²	150-300 mm ²
	Tensile strength	-	3 Nm	5-6 Nm	6-8 Nm	6-8 Nm
Prism fixing for flexible copper rail, for flexible or rigid multicore copper and aluminium cables	Connection	-	16-70 mm ²	70-150 mm ²	120-240 mm ²	150-300 mm ²
	Tensile strength	-	3 Nm	5-6 Nm	6-8 Nm	6-8 Nm
Other fixings	Connection	Cage terminals 1.5-50 mm ²	3 inputs connector Cat.No 6052 26 3 x 1.5-16 mm ²	-	-	-
	Tensile strength	4 Nm	3 Nm	-	-	-

		SPX-V 00 60 mm	SPX-V 00 100 mm	SPX-V 1	SPX-V 2	SPX-V 3
Lug mounting	Connection	M 8	M 8	M 10	M 10	M 12
	Tensile strength	12-14 Nm	12-14 Nm	30-35 Nm	30-35 Nm	35-40 Nm
Flat fixing for flexible copper rail, for flexible or rigid copper and multi-core cables	Connection	1,5-70 mm ²	1,5-70 mm ²	120-240 mm ²	120-240 mm ²	120-240 mm ²
	Tensile strength	3 Nm	3 Nm	6-8 Nm	6-8 Nm	6-8 Nm
Prism fixing for flexible copper rail, for flexible or rigid multicore copper and aluminium cables	Connection	16-70 mm ²	16-70 mm ²	120-240 mm ²	120-240 mm ²	120-240 mm ²
	Tensile strength	3 Nm	3 Nm	6-8 Nm	6-8 Nm	6-8 Nm

SPX-D	160 A	250 A	400 A	630 A
Rigid cable (Cu) max. (mm)	95	240	240	2 x 185
Bar (Thickness/Width) max. (mm)	3/25	6/40	6/40	2 x 7/50
Tightening torque (Nm)	13	24	24	45

SPX fuse carriers and fused isolating switches (continued)

DIMENSIONS

SPX

■ SPX 000

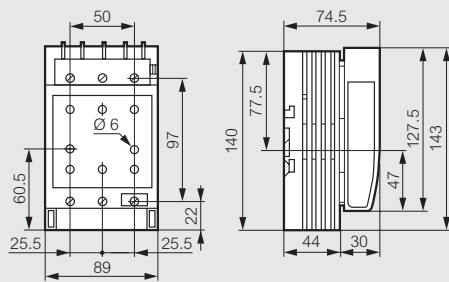

Installing on 60 mm collector rail

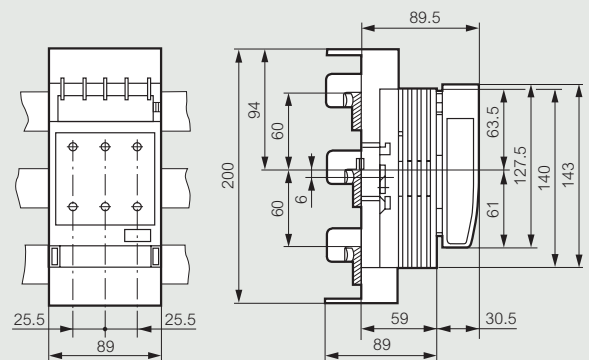

■ SPX 00/1/2/3

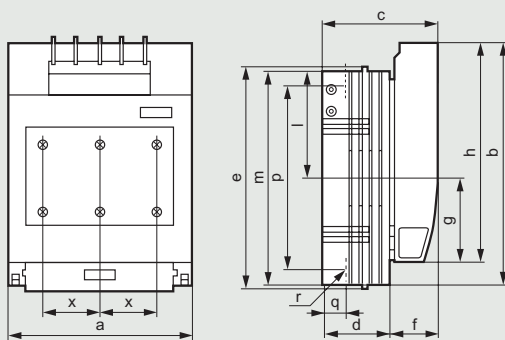

Installing on 60 mm collector rail

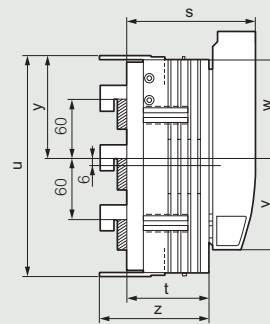

	a	b	c	d	e	f	g	h	l	m	p	q	r	x
SPX 0	106	176	82.5	45	-	37	60	155	70	151	115	17	M8	33
SPX 1	184	243	111.5	66	220	45.5	84	220	107	214.5	185	21.5	M10	57
SPX 2	210	288	128	80	-	48	92	249	124	255	210	25	M10	65
SPX 3	256	300	142.5	94.5	-	48	98.5	259	127.5	267	210	30	M12	81

	s	t	u	v	w	y	z
SPX 0	97	59.5	200	94	62	94	87
SPX 1	128.5	83	221	90	101	104.5	110.5
SPX 2	145	97	228	98	118	128	124.5
SPX 3	159.5	111.5	285	104.5	121.5	136.5	139

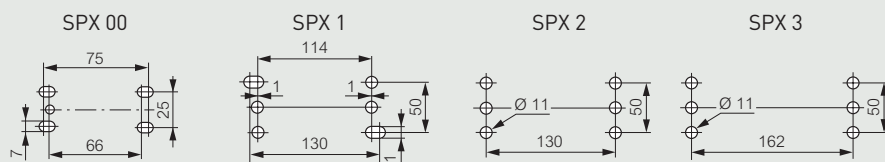

SPX-V

■ SPX-V 00 on 60 mm collector rail

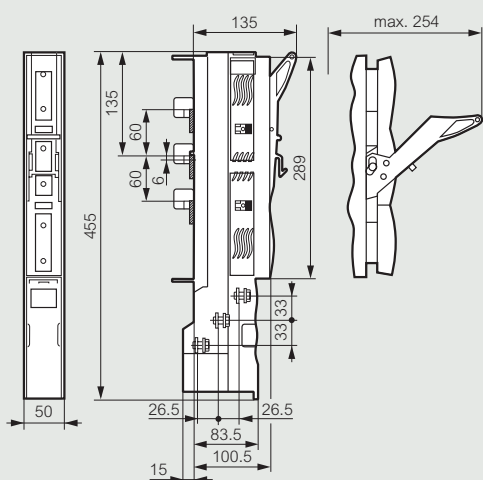

■ SPX-V 00 on 185 mm collector rail using a collector rail adaptor

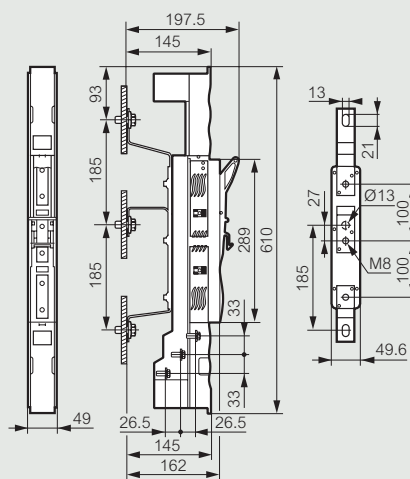

■ SPX-V 00 on 100 mm collector rail

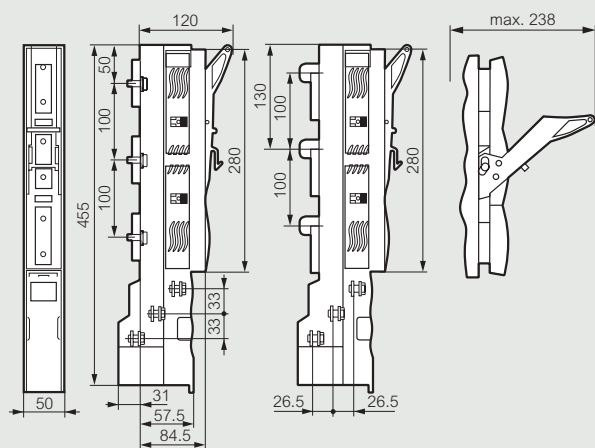

■ SPX-V 1/2/3 on 185 mm collector rail

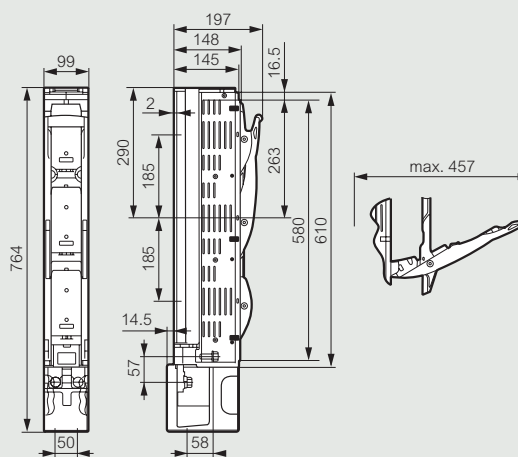

SPX fuse carriers and fused isolating switches (continued)

SPX-D

■ SPX-D 160 A without handle

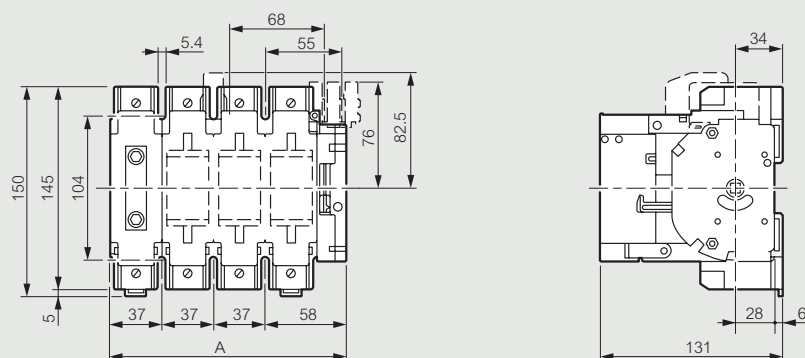

with direct handle

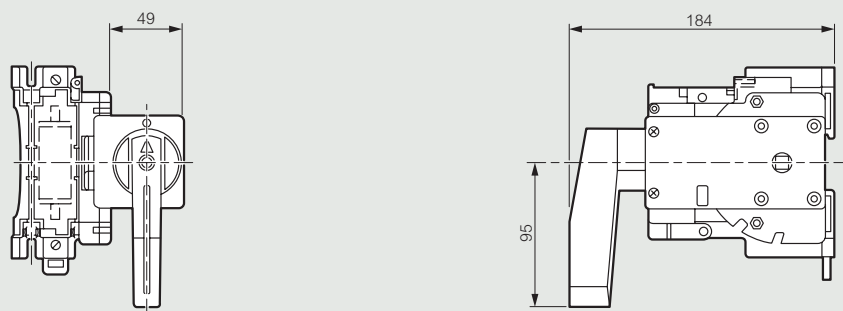

with external handle

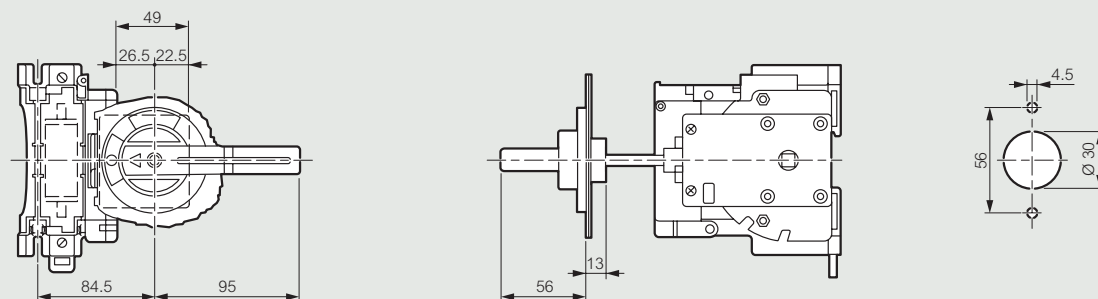

SPX-D

■ SPX-D 160 A and 400 A with direct handle

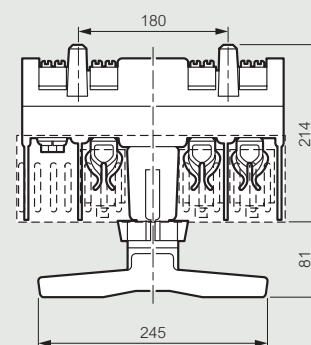
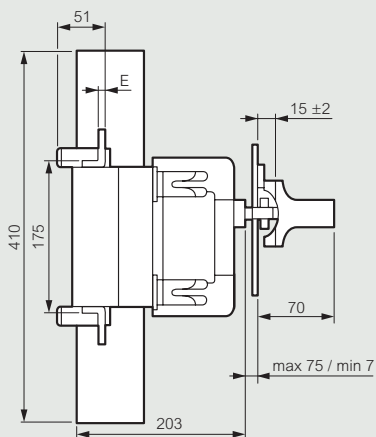
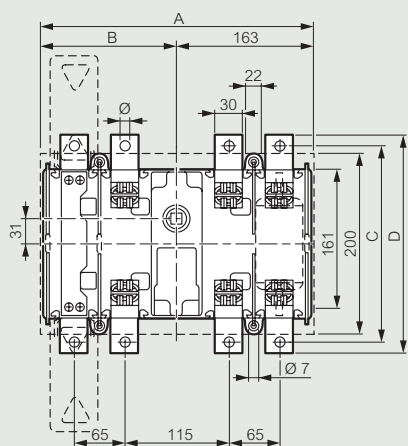

Dimensions (mm)		A	B	C	D	E	Ø	ØT
250 A	3P	274	111	216	246	4	10.5	M10
	3P + N	329	166	216	246	4	10.5	M10
400 A	3P	274	111	216	246	5	10.5	M10
	3P + N	329	166	216	246	5	10.5	M10

■ SPX-D 630 A with direct handle

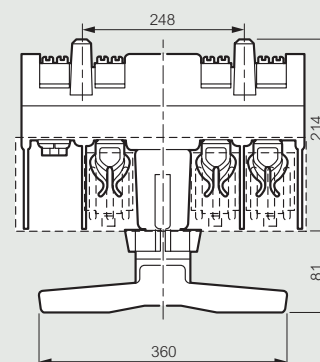
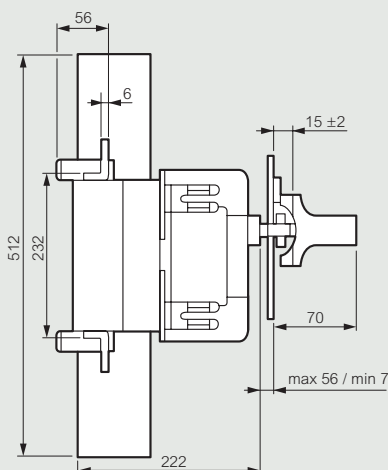
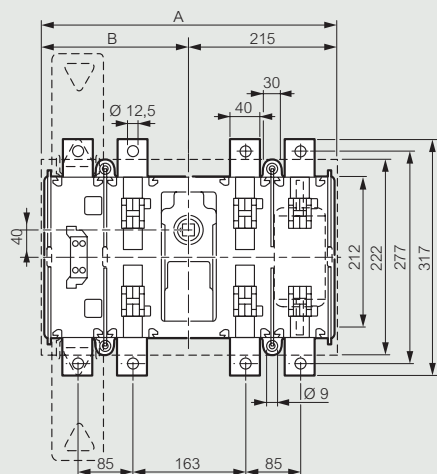

Dimensions (mm)		A	B	ØT
250 A	3P	381	166	M12
	3P + N	426	211	M12

Back-up protection

Back-up protection is the technique by which the breaking capacity of a circuit breaker is increased by coordinating it with another protection device, placed upstream. This coordination makes it possible to use a protection device with a breaking capacity which is lower than the maximum prospective short-circuit current at its installation point.

The breaking capacity of a protection device must be at least equal to the maximum short circuit which may occur at the point at which this device is installed. The breaking capacity of a device can be lower than the maximum prospective short circuit (see IEC 60364-4-435), provided that:

- It is combined with a device upstream that has the necessary breaking capacity at its own installation point,
- The downstream device and the protected trunking can withstand the energy limited by the combination of the devices.

Substantial savings can therefore be made by combining devices.

The Back-up values given in the tables on the following pages are based on laboratory tests carried out in accordance with IEC 60947-2.



For single phase circuits (protected by 1P+N or 2P circuit breakers) in a 380/415 supply, supplied upstream by a 3-phase circuit, it is advisable to use the combination tables for 230 V.

Example of back-up protection

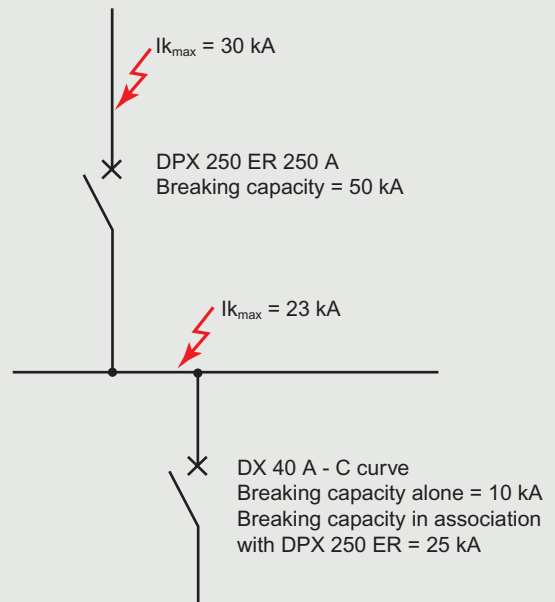

3-level back-up

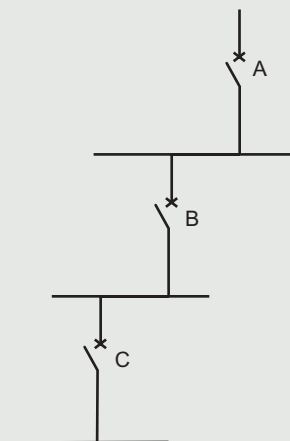

A combination may be created on three levels if either of the following conditions is met:

- **Combination with the main device**

Upstream device A must have an adequate breaking capacity at its point of installation. Devices B and C are combined with device A. Simply check that the B + A and C + A combination values have the necessary breaking capacities. In this case, there is no need to check the combination of devices B and C.

- **Cascaded combination**

The combination is made between successive devices: upstream device A has an adequate breaking capacity at its point of installation. Device C is combined with device B, which is itself combined with device A. Simply check that the C + B and B + A combination values have the necessary breaking capacities.

In this case, there is no need to check the combination of devices A and C.

Back-up between distribution boards

Combination applies to devices installed in the same distribution board and also in different boards.

It is therefore generally possible to benefit from the advantages of combining devices located, for example, in a main distribution board and in a secondary board. The upstream device must always have the necessary breaking capacity at its installation point.

It is also possible to benefit from the combination of device B (for example a DX with a breaking capacity of 10 kA) and the secondary devices C (1P+N DX with a breaking capacity of 6 kA) on distribution board no. 2. Under these conditions the DX + DNX combination has a breaking capacity of 25 kA.

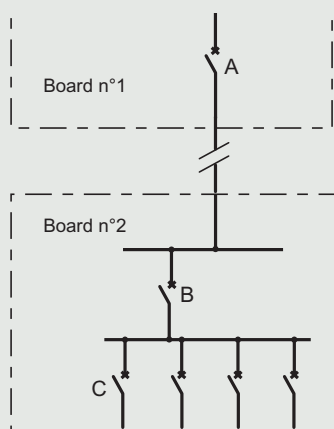

Back-up in IT earthing systems

The values given in the tables on the following pages are only for use in TN and TT earthing systems. Although this practice is not widely used, these values may also be used for installations with IT systems. It is therefore advisable to check that each individual protection device can break the maximum double fault current at the point in question on a single pole.

BACK-UP BETWEEN ACBs AND MCCBs

In 3 phases networks

Downstream MCCB	Upstream ACB								
	DMX ³ -N			DMX ³ -H			DMX ³ -L		
	800 & 1000 A	1250 A	1600 to 4000 A	800 & 1000 A	1250 A	1600 to 4000 A	800 & 1000 A	1250 A	1600 to 4000 A
DPX 250	50	50	50	65	65	65	100	100	100
DPX 630	50	50	50	65	65	65	100	100	100
DPX 1250		50	50		65	65		100	100
DPX 1600			50			65			100

Back-up protection (continued)

BACK-UP BETWEEN MCCBs AND MCBs

In 3 phases networks with neutral - 400/415 V - according to IEC 60947-2

MCBs downstream		MCBs/MCCBs upstream							
		DX-H [10000] - 25 kA B and C curves			DX-L		DPX-E 125	DPX 125	DPX 160 DPX-H 160
		2 to 32 A	40 to 125 A	10 to 32 A	40 to 63 A	16 to 125 A	16 to 125 A	25 to 160 A	
DX [6000] - 10 kA B and C curves	1 to 20 A	25 ⁽¹⁾	12.5	50	25	16	25	25	
	25 A	25 ⁽¹⁾	12.5	50	25	16	25	25	
	32 A		12.5		25	16	25	25	
	40 A		12.5		25	16	25	25	
	50 A				25	16	25	20	
	63 A					16	25	15	
	80 A						20	25	
	100 A						20	25	
DX-H [10000] - 25 kA B and C curves DX 6000 - 15 kA D curve	1 to 16 A			50	25	16	25	25	
	20 A			50	25	16	25	20	
	25 A				25	16	25	15	
	32 A				25	16	25	20	
	40 A				25	16	25	20	
	50 A				25	16	25	15	
63 A					16	25	25		
DX-L - 50 kA - C curve	10 to 63 A			50	50			50	

In 3 phases networks with neutral - 230/240 V - according to IEC 60947-2

MCBs downstream		MCBs/MCCBs upstream							
		DX-H [10000] - 25 kA B and C curves			DX-L		DPX-E 125	DPX 125	DPX 160 DPX-H 160
		2 to 32 A	40 to 63 A	80 to 125 A	10 to 32 A	40 to 63 A	16 to 125 A	16 to 125 A	25 to 160 A
DX [6000] - 10 kA B and C curves	1 to 20 A	50	25	20	50	25	22	35	35
	32 & 40 A		25	20		25	22	35	35
	50 A					25	16	25	25
	63 A						16	25	15
	80 A						16	25	25
	100 A						16	25	25
	125 A								25
DX-H [10000] - 25 kA B and C curves DX [6000] - 15 kA D curve	1 to 40 A				50	25	22	35	35
	50 A					25	16	25	25
	63 A						16	25	25
DX-L - 50 kA - C curve	10 to 63 A				70	70			70

TT or TN earthing systems: for a 230/240 V supply, in order to determine the breaking capacity of a 2P MCB used as L+N (230 V) downstream a 2P or 4P circuit breaker use values indicated in the table for 230/240 V network

	DPX 250 ER				DPX/H/L 250		DPX/H/L 630	DPX/H/L 630 electronic		DPX/H/L 1250	DPX/H/L 1600
	63 A	100 A	160 A	250 A	160 A	250 A	250 to 400 A	160 & 400 A	630 A	500 to 1250 A	800 to 1600 A
	25	25	25	25	25	25	25	25	25	25	25
	25	25	25	25	25	25	25	25	25	20	20
	25	25	25	25	25	25	25	25	25	15	15
	25	25	25	25	25	20	20	20	20	15	15
	25	25	20	20	20	15	15	15	15	12.5	12.5
		20	15	15	15	15	15	15	15	12.5	12.5
			20	20	20	20	20	20	15		
			20	20	20	20	20	20	15		
			15	15	15	15	15	15	10		
	25	25	25	25	25	25	25	25	25	25	25
	25	25	25	25	25	25	25	25	25	25	25
	25	25	25	25	25	25	25	25	25	20	20
	25	25	25	25	25	25	25	25	25	15	15
	25	25	25	25	25	20	20	20	20	15	15
	25	25	20	20	20	15	15	15	15	12.5	12.5
	25	20	15	15	15	15	15	15	15	12.5	12.5
	50	50	50	50	50	50	50	50	50	50	50

	DPX 250 ER				DPX/H/L 250			DPX/H/L 630 electronic		DPX/H/L 1250	DPX/H/L 1600
	63 A	100 A	160 A	250 A	160 A	250 A	250 to 400 A	160 & 400 A	630 A	500 to 1250 A	800 to 1600 A
	50	50	50	50	50	50	50	50	50	50	50
	50	50	50	50	50	50	50	50	50	50	50
	36	36	36	36	36	30	30	30	25	25	25
		30	30	30	30	30	30	30	25	25	25
		25	25	25	25	25	25	25	20		
			25	25	25	25	25	25	20		
			25	25	25	25	25	25	20		
	50	50	50	50	50	50	50	50	50	50	50
	36	36	36	36	36	30	30	30	25	25	25
		30	30	30	30	30	30	30	25	25	25
	70	70	70	70	70	70	70	70	70	70	70

Back-up protection (continued)

BACK-UP BETWEEN FUSE CARTRIDGES AND MCBs

**In 3 phases network with neutral
400/415 V according to IEC 60947-2**

MCBs downstream		Fuses upstream gG type	
		20 to 32 A	63 to 160 A
DX [6000] - 10 kA C and D curves	1 to 40 A	100	100
	50 A to 125 A		100
DX-H [10000] - 25 kA B and C curves	2 A to 40 A	100	100
	50 A to 63 A		100
DX-L 50 kA C curve	10 A to 40 A	100	100
	50 A to 63 A		100

**In 3 phases network with neutral
230/240 V according to IEC 60947-2**

MCBs downstream		Fuses upstream gG type	
		20 to 32 A	63 to 160 A
DX [6000] - 10 kA C and D curves	1 to 40 A	100	100
	50 A to 125 A		100
DX-H [10000] - 25 kA B and C curves	2 A to 40 A	100	100
	50 A to 63 A		100
DX-L 50 kA C curve	10 A to 40 A	100	100
	50 A to 63 A		100

BACK-UP BETWEEN CIRCUIT BREAKERS AND SWITCHES

> Overloads

Switch I is considered to be protected against overloads if its rating is at least equal to that of the upstream circuit breaker D, or if the sum of the currents of the devices C is not greater than the rating of I. If this is not the case, the thermal stresses of the devices and the conductors must be checked.

> Short circuits

In principle, switches must be systematically protected by a circuit breaker placed upstream (see table below). However, it is possible for the protection to be provided by the devices placed downstream, by taking the necessary wiring precautions to prevent any risk of a short circuit between these devices and the switch, which must all be located in the same distribution board.

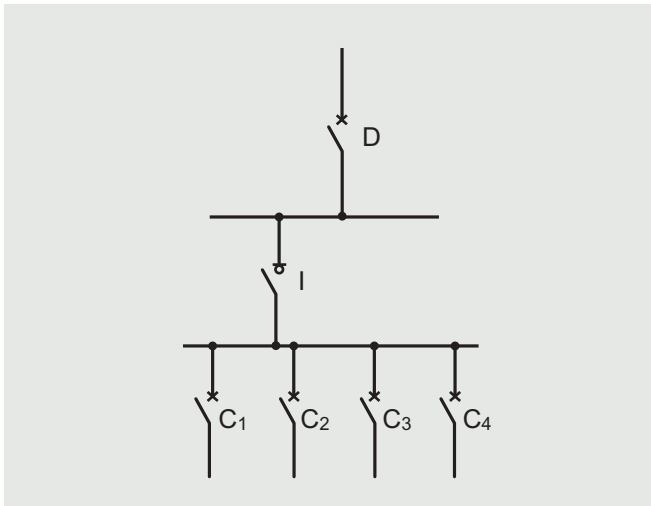

Back-up between DX circuit breakers and RCCBs (in kA)

Downstream RCCBs	Upstream circuit breakers						
	DX curve C						
	1P + N	< 40 A	50 and 63 A	DX-H ≤ 63 A	DX-H 80-125	DPX 125 A	
2-pole 230 V 4-pole 400 V	16 A	6	10	10	20	20	25
	25 A	6	10	10	20	20	25
	40 A	6	10	10	15	20	25
	63 A		10	10	12.5	12.5	25
	80 A				12.5	12.5	25

Back-up between DPX circuit breakers and DPX-I switches (in kA)

Downstream switch	Upstream circuit breaker														
	DPX 125			DPX 160		DPX 250 ER		DPX 250		DPX 630		DPX 1600 (MT)		DPX 1600 (EI)	
	16 kA	25 kA	36 kA	25 kA	50 kA	25 kA	50 kA	36 kA	70 kA	36 kA	70 kA	50 kA	70 kA	50 kA	70 kA
DPX-I 125	16	25	36	25	50	25	50	36	50	36	70	50	50		
DPX-I 160				25	50	25	50	36	50	36	70	36	50		
DPX-I 250 ER				25	50	25	50	36	50	36	70	36	50		
DPX-I 250								36	70	36	70	50	70		
DPX-I 630 In=400 A										36	70	50	70		
DPX-I 630 In=630 A												50	70		
DPX-I 1600 In=800 A												50	70		
DPX-I 1600 In=1250 A												50	70	20	20
DPX-I 1600 In=1600 A														20	20

Back-up between DPX circuit breakers and Vistop or DPX-I switches (in kA)

Downstream switch	Upstream circuit breaker														
	DPX 125			DPX 160		DPX 250 ER		DPX 250		DPX 630		DPX 1600 (MT)		DPX 1600 (EI)	
	16 kA	25 kA	36 kA	25 kA	50 kA	25 kA	50 kA	36 kA	70 kA	36 kA	70 kA	50 kA	70 kA	50 kA	70 kA
Vistop 63	16	25	36	25	36	25	36	36	50	36	50	36	36	36	36
Vistop 160				25	36	25	36	36	50	36	50	36	36	36	36
DPX-IS 250						25	36	36	50	36	50	36	36	36	36
DPX-IS 400										36	50	50	70	36	36
DPX-IS 630										36	50	50	70	36	50

Selectivity between protection devices

Selectivity is a technique which consists of coordinating the protection in such a way that a fault on one circuit only trips the protection placed nearest to the fault, thus avoiding the rest of the installation being put out of service. Selectivity improves continuity of service and safety of the installation

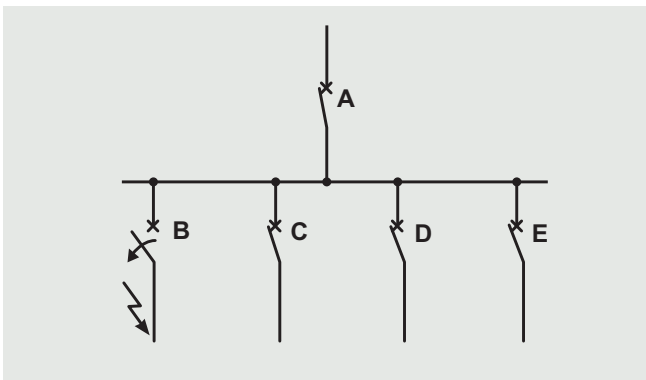

> Total Selectivity

Selectivity between A and B is said to be “total” if it is provided up to the value of the maximum prospective short circuit at the point at which B is installed. In the selectivity tables, total selectivity “T”, indicates that there is selectivity up to the breaking capacity of device B. When the selectivity tables do not give “T”, the value given must be compared with the prospective short-circuit value at the installation point to check whether the selectivity is total.

> Partial selectivity

Selectivity between A and B is said to be “partial” when the short-circuit level is higher than the value given in the selectivity tables. This value defines the selectivity limit below which only circuit breaker B will open and above which circuit breaker A will open as well. There are a number of techniques for implementing selectivity:

- Current sensing selectivity, used for terminal circuits which have low short-circuit levels
- Time selectivity, provided by a delay on the tripping of the upstream circuit breaker
- Dynamic selectivity, making optimum use of the characteristics of the Legrand devices
- Logical selectivity, making use of the communication possibilities between devices



Since almost all faults occur during use, partial selectivity may be adequate if the selectivity limit is higher than the value of the maximum short circuit which may occur at the point of use (or at the end of the trunking). This is referred to as “operating selectivity”. This technique is very often adequate, more economical and less restricting in terms of implementation.

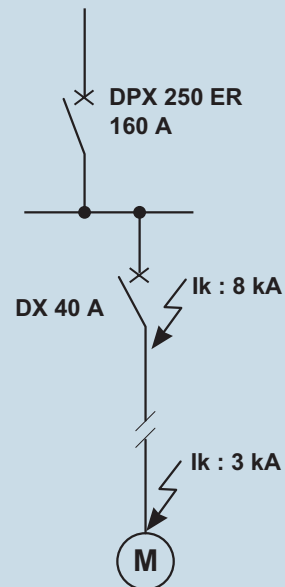

The selectivity limit of the combination of the DPX 250 ER 25 kA (160 A) and the DX 10 kA (40 A - curve C) is 6 kA.

As the maximum short-circuit level ($I_{k \max}$) at the installation point is 8 kA, the selectivity is not total.

However, there is total selectivity at the point of use where the prospective short circuit is only 3 kA.

CURRENT SENSING SELECTIVITY

This technique is based on the difference in the intensity of the tripping curves of the upstream and downstream circuit breakers. It is checked by comparing these curves and ensuring that they do not overlap. It applies for the overload zone and the short-circuit zone, and the further apart the ratings of the devices, the better the selectivity.

• Overloads

To have selectivity in the overload zone, the ratio of the setting currents (I_r) must be at least 2.

• Short circuits

To have selectivity in the short-circuit zone, the ratio of the magnetic setting currents (I_m) must be at least 1.5.

The selectivity limit is then equal to the magnetic tripping current I_{m_A} of the upstream circuit breaker. The selectivity is then total as long as I_{k_B} is lower than I_{m_A} .

Current sensing selectivity is therefore very suitable for terminal circuits where the short circuits are relatively weak.

Current sensing selectivity

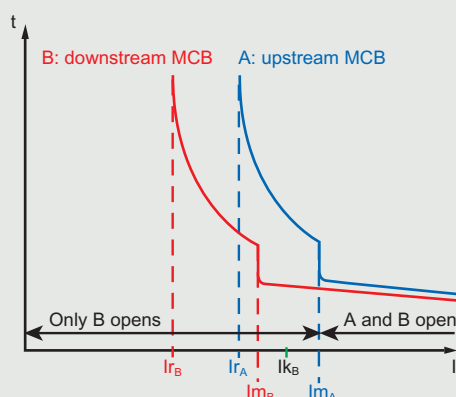

I_{k_B} : maximum short-circuit at the point at which MCB B is installed

The selectivity is total for I_{k_B}

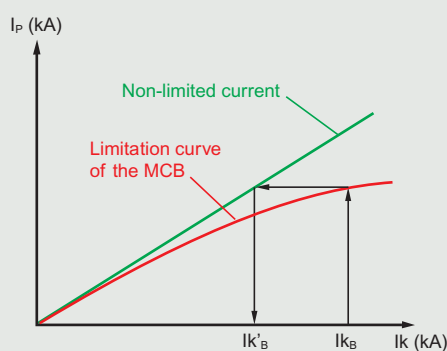

I_{k_B} : prospective short-circuit at the point at which the device is installed
 $I_{k'_B}$: short-circuit limited by device B

When the downstream circuit breaker, B, is a limiting device, the short-circuit current is limited in terms of both time and amplitude. The Selectivity is therefore total if the limited current I_{k_B} which device B allows to pass is lower than the tripping current of device A.

Selectivity between protection devices (continued)

TIME SELECTIVITY

This technique is based on the difference in the times of the tripping curves of the circuit breakers in series. It is checked by comparing the curves and is used for selectivity in the short-circuit zone. It is used in addition to current sensing selectivity in order to obtain selectivity beyond the magnetic setting current of the upstream circuit breaker (I_{m_A}). The following is therefore necessary:

- It must be possible to set a time delay on the upstream circuit breaker
- The upstream circuit breaker must be able to withstand the short-circuit current and its effects for the whole period of the time delay
- The trunking through which the current passes must

be able to withstand the thermal stresses (I^2t). The non-tripping time of the upstream device must be longer than the breaking time (including any time delay) of the downstream device. DPX and DMX³ circuit breakers have a number of time delay setting positions for creating selectivity with a number of stages.

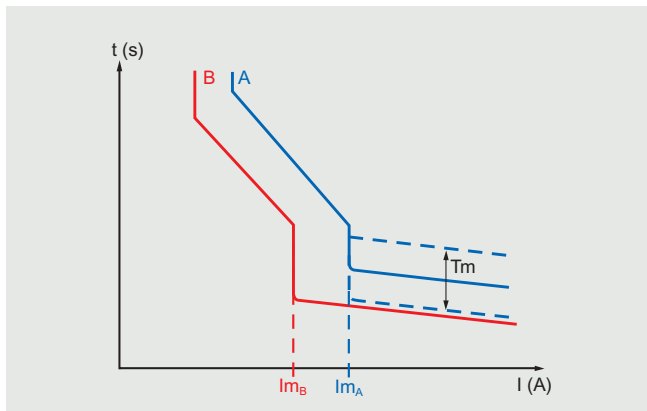

Electronic releases with constant I^2t setting

The use of circuit breakers with electronic releases on which a constant I^2t setting is possible improves the selectivity.

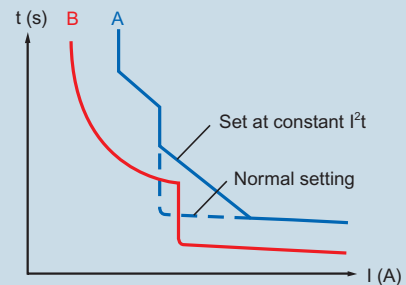

Removal of the unwanted short delay section of the tripping curve on the upstream circuit breaker avoids overlapping of the tripping curves. This option is available on DMX³ and S2 electronic DPX.

DYNAMIC SELECTIVITY

Dynamic selectivity is a particular type of selectivity developed by Legrand. It is based on making maximum use of the limitation characteristics of moulded case circuit breakers and extends the concept of time coordination to the highest short-circuit currents.

Dynamic selectivity is implemented between two levels of circuit breakers by installing:

- Upstream: electronic DPX circuit breakers with S1 or S2 type releases.
- Downstream: electronic DPX circuit breakers with S1

or S2 type releases, or thermal-magnetic DPX or even DX circuit breakers.

Each type S1 and S2 electronic release has a rotary selector switch SEL with two positions:

- High: to obtain high levels of selectivity
 - Low: to obtain standard levels of selectivity.
- The electronic DPX circuit breaker set to "SEL = High" inserts a short activation delay which enables high levels of selectivity to be achieved even for high intensity short-circuit currents.



This solution is particularly advisable for installations characterised by high short-circuit current values, where the circuit breakers concerned by the two levels of dynamic selectivity are in the same consumer unit, and when the line to be protected has one of the following characteristics:

- Length \leq 3 metres
- Double insulation (if the line to be protected is a cable).

Before studying the dynamic selectivity, the time selectivity in the medium intensity short-circuit intervention zone must be checked on the tripping curves. When this condition has been checked, the following rules must be applied:

- The SEL selector switch on the electronic DPX installed upstream of the selectivity system must be set to "High"
- The circuit breaker installed downstream of the selectivity system can be an electronic DPX with the SEL selector switch set to "Low", a thermal-magnetic DPX or a DX.



■ **Advantages**

- Higher selectivity limits (for high intensity short-circuit currents) than the conventional current sensing selectivity limits
- Better continuity of service and safer than with current sensing selectivity
- Flexible, simple and economical solution

■ **Disadvantages**

- Two-level selectivity only
- Introduction of a short activation delay with a consequence on the thermal stress limitation curves

Examples of dynamic selectivity between two levels

■ **Upstream**

- A: electronic DPX with "S2" release and the SEL selector switch set to High ($t_m = 0.2$, considered to be result of the previous time selectivity study on medium intensity short circuit)

■ **Downstream**

- B: electronic DPX with "S2" release and the SEL selector switch set to Low ($t_m = 0.1$, considered to be result of the previous time selectivity study on medium intensity short circuit)

- D: electronic DPX with "S1" release and SEL selector switch set to Low.

It is possible to install other circuit breakers downstream of the two dynamic selectivity levels: C (thermal-magnetic DPX) and E (DX).

For high intensity short-circuit currents downstream of C or downstream of E, the selectivity with the upstream devices is no longer dynamic but current sensing.

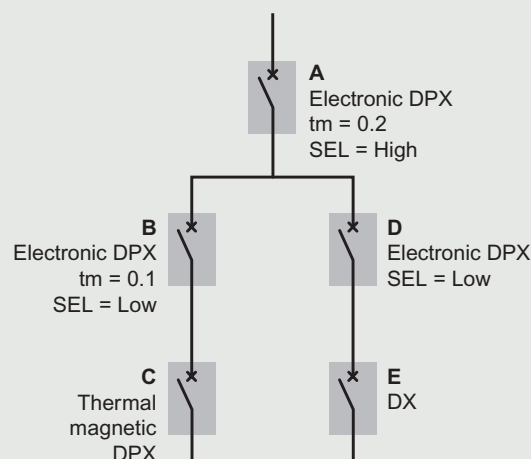

Selectivity between protection devices (continued)

LOGICAL SELECTIVITY

Logical selectivity is an “intelligent” type of selectivity performed by exchanging data between electronic DPX or DMX³ linked by an external connection.

Logical selectivity concentrates on the medium and high intensity short-circuit zone.

Thus, if there is a short circuit, the part of the installation affected by the fault is immediately identified and isolated using the circuit breaker placed directly upstream.

This acts immediately, without taking account of the various time delay settings, which therefore reduces to the absolute minimum, the time taken to eliminate the fault. This enables the following:

- Selectivity on several levels, in addition to the various time delays
- Considerable reduction of the thermal and electrodynamic stresses in the cables or bars, and thus optimisation of the dimensions of the installation.

Logical selectivity can be implemented using:

- Electronic DPX circuit breakers with S2 protection unit, with a 12 V DC external auxiliary power supply.
- DMX³ circuit breakers with MP4 or MP6 electronic protection unit.

If there is a short circuit (medium or high intensity) in the installation, the logical selectivity operating principle is as follows:

- The circuit breaker that detects the short-circuit current sends a signal, via the connecting cable, to the circuit breaker located immediately upstream, while checking that there is no signal from a device located downstream.
- If the circuit breaker that detected the fault does not receive any command from a device downstream, it operates immediately without taking account of any programmed time delays (eg: T_m and/or $SEL = High$).
- However, if the circuit breaker in question receives a signal from a downstream device, it will remain closed, keeping to the programmed time delays (eg: T_m and/or $SEL = High$).



Application rules

- To ensure logical selectivity on medium intensity short circuits, the constant time tripping curve (T_m) must be used. Using the constant I^2t curve does not allow correct operation of the logical selectivity
- All the circuit breakers on the logical selectivity system, apart from the last device on the system, must have the SEL selector switch set to High, with T_m equal to or greater than 100 ms.
- The time delay settings T_m of the circuit breakers installed at the same level in the logical selectivity system (apart from the last level) can be identical.
- All the circuit breakers located at the last level of the logical selectivity system must have the SEL selector switch set to Low, with a T_m lower than that of the circuit breakers at higher levels.

Connection to electronic DPX

Each electronic DPX (version S2) has the following:

- On the front panel:
 - A two-position selector switch SEL, which can be set to High and Low
- On the side-mounted draw-out terminal block:
 - 2 logical selectivity inputs, intended for the link with the circuit breakers located downstream
 - 2 logical selectivity outputs, intended for the link with the circuit breakers located upstream

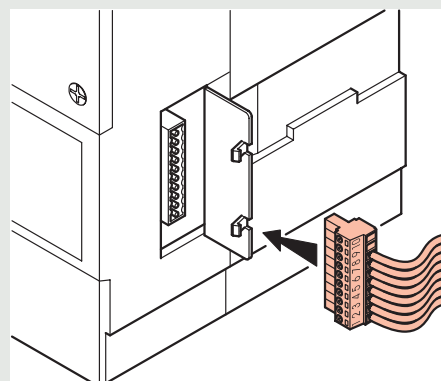

Examples of 3-level logical selectivity

■ Fault 1: short circuit downstream of A

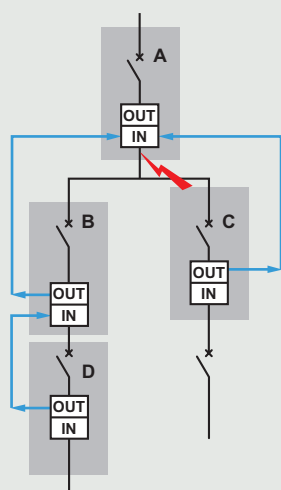

Only circuit breaker A detects the fault. Since it does not receive any signal from the circuit breakers downstream, it trips immediately, without taking account of the various programmed time delays.

■ Fault 2: short circuit downstream of B

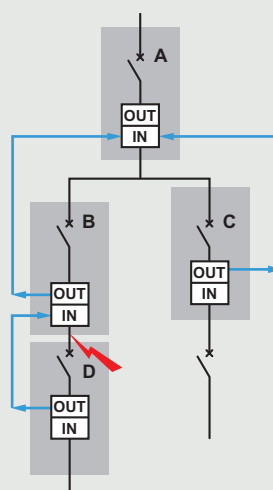

Circuit breakers A and B detect the fault. Circuit breaker A receives a signal from the downstream circuit breaker B. It therefore remains closed, keeping to the programmed time delays. However, since circuit breaker B does not receive any signal from the circuit breakers downstream, it trips immediately, without taking account of the various programmed time delays.

In both the cases described above, to prevent a double connection to circuit breaker A, it is also possible to use the following wiring:

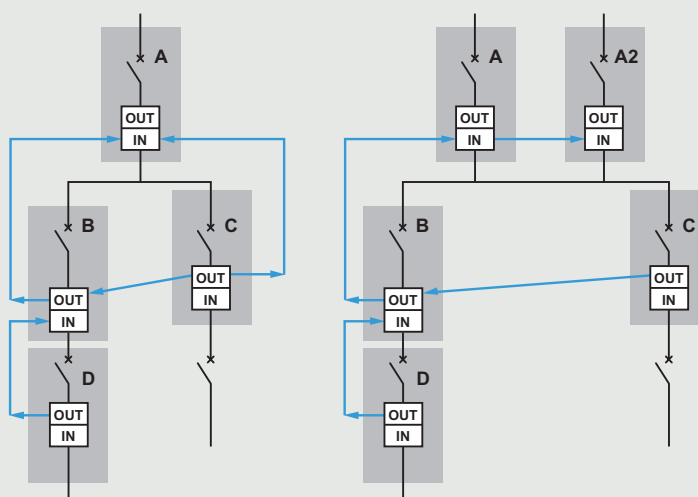

Selectivity between protection devices (continued)

Technical data	
Maximum number of electronic DPX that can be connected	unlimited
Maximum total length of the wired link	unlimited
Maximum length of the wired link between two devices	30 metres
Type of cable and installation	CU cable 1.5 mm ² or shielded cable

Logical selectivity is particularly suitable for installations characterised by high short-circuit current values and with high continuity of service requirements.



■ Advantages

- Reduction of the thermal and electrodynamic stresses on the cables or bars, thus optimising the dimensions of the installation
- Creation of selectivity on a number of levels, in addition to the various time delays provided by the time selectivity.

■ Disadvantages

- Need for an auxiliary power supply and a wired link between the circuit breakers
- DPX must be fitted with type S2 electronic protection.

! What happens if there is a break in the wired link or the auxiliary power supply?

In both cases, there is no longer selectivity between the circuit breakers.

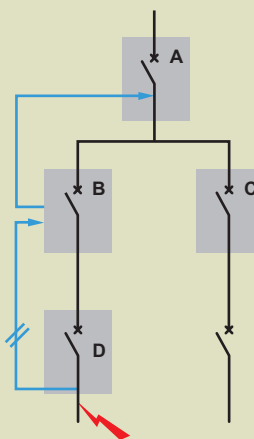

■ Situation 1: If there is a break in the logical selectivity wired link between D and B, in the event of a short circuit downstream of D, B will act immediately without taking account of any programmed time delays, thus ensuring the installation is protected.

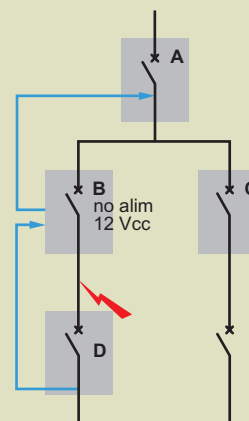

■ Situation 2: If there is a break in the 12 V DC auxiliary power supply of B, in the event of a short circuit downstream of B, A will act immediately, thus ensuring the installation is protected.

Checking selectivity with XL Pro² Calculation

Legrand software “XL Pro² Calculation” offers several ways to check the selectivity. In the example below, with a 630 kVA transformer, the selectivity is total between the upstream DPX 1600 breaker and the downstream DPX 630.

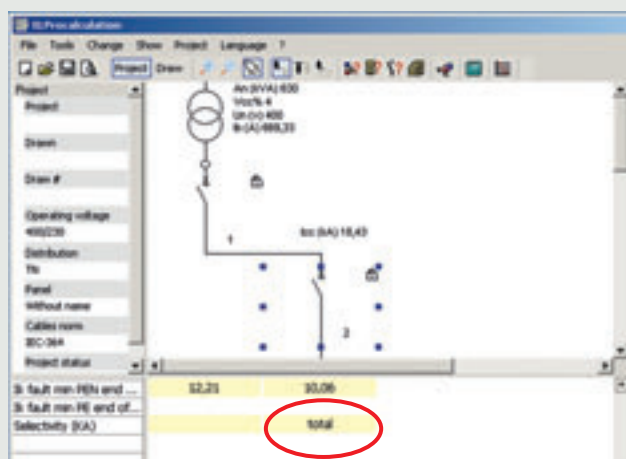

< The selectivity can be checked directly in the resulting data of the concerned line . . .

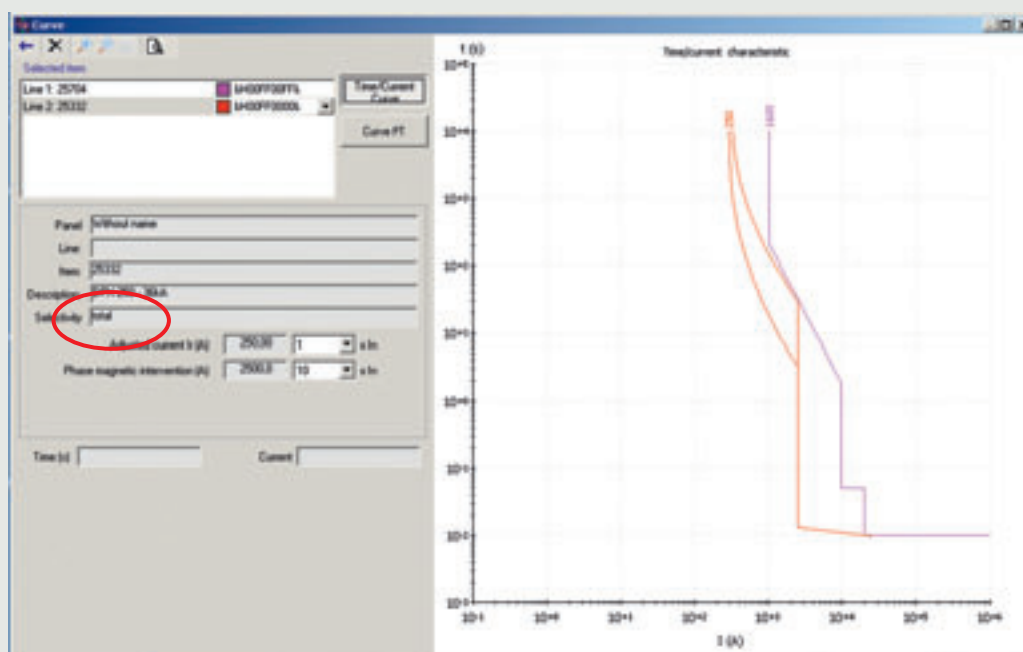

< . . . or drawing and comparing the tripping curves of the circuit breakers

Selectivity between protection devices (continued)

SELECTIVITY TABLES (3-phase network 400/415 V AC)

DMX ³ / DMX ³									
Downstream ACB		Upstream ACB							
		DMX ³ 2500					DMX ³ 4000		
		800 A	1000 A	1250 A	1600 A	2000 A	2500 A	3200 A	4000 A
DMX ³ 2500	800 A		T	T	T	T	T	T	T
	1000 A			T	T	T	T	T	T
	1250 A				T	T	T	T	T
	1600 A					T	T	T	T
	2000 A						T	T	T
DMX ³ 4000	2500 A						T	T	T
	3200 A								T
	4000 A								

DMX ³ / DX and DMX ³ / DPX									
Downstream MCCB		Upstream ACB							
		DMX ³ 2500					DMX ³ 4000		
		800 A	1000 A	1250 A	1600 A	2000 A	2500 A	3200 A	4000 A
DX/DX-H/DX-L		T	T	T	T	T	T	T	T
DPX 125/160/250 ER ⁽¹⁾		T	T	T	T	T	T	T	T
DPX 250 ⁽¹⁾		T	T	T	T	T	T	T	T
DPX 630 ⁽¹⁾		T	T	T	T	T	T	T	T
DPX 1250 ⁽¹⁾ thermal magnetic	630 A	T	T	T	T	T	T	T	T
	800 A		T	T	T	T	T	T	T
	1000 A			T	T	T	T	T	T
	1250 A				T	T	T	T	T
DPX 1600 ⁽¹⁾ electronic	630 & 800 A			T	T	T	T	T	T
	1000 A				T	T	T	T	T
	1250 & 1600 A					T	T	T	T

(1) All breaking capacity

DMX-E / DMX-E					
Downstream DMX-E	Upstream DMX-E				
	1600 A	2000 A	2500 A	3200 A	4000 A
800 A	T	T	T	T	T
1000 A		T	T	T	T
1250 A			T	T	T
1600 A				T	T
2000 A					T

DMX-E / DPX				
Downstream MCCB	Upstream DMX-E			
	800 & 1000 A	1250 A	1600 to 2500 A	3200 & 4000 A
DPX 125/160/250 ER	T	T	T	T
DPX 630	250 to 400 A	T	T	T
	630 A		T	T
DPX 1600	800 A		T	T
	1250 to 1600 A			T

Thermal-magnetic DPX / DPX																					
Upstream MCCB	DPX 125 (16, 25, 36 kA)				DPX 160/250 ER (25, 36, 50 kA)				DPX 250 DPX-H 250				DPX 630 DPX-H 630					DPX 1250 DPX-H 1250			
In (A)	40	63	100	125	63	100	160	250	63	100	160	250	250	320	400	500	630	800	1000	1250	
I _{st} ⁽¹⁾ (kA)	0.8	0.95	1.25	1.25	0.63	1	1.6	2.5	0.63	1	1.6	2.5	2.5	3.2	4	5	6.3	8	6	7.5	
Downstream MCCB																					
DPX 125 (16 kA)	16	0.8	1	1.2	1.2	0.63	1	1.6	2.5	0.63	1	1.6	2.5	6	6	6	6	8	T	T	T
	25	0.8	1	1.2	1.2		1	1.6	2.5		1	1.6	2.5	6	6	6	6	8	T	T	T
	40		1	1.2	1.2		1	1.6	2.5		1	1.6	2.5	6	6	6	6	8	T	T	T
	63			1.2	1.2			1.6	2.5			1.6	2.5	6	6	6	6	8	T	T	T
	100							1.6	2.5			1.6	2.5	4	4	4	4	6	8	T	T
125							1.6	2.5			1.6	2.5	4	4	4	4	6	8	T	T	T
DPX 125 (25, 36 kA)	16	0.8	1	1.2	1.2	0.63	1	1.6	2.5	0.63	1	1.6	2.5	6	6	6	6	8	16	16	16
	25	0.8	1	1.2	1.2		1	1.6	2.5		1	1.6	2.5	6	6	6	6	8	16	16	16
	40		1	1.2	1.2		1	1.6	2.5		1	1.6	2.5	6	6	6	6	8	16	16	16
	63			1.2	1.2			1.6	2.5			1.6	2.5	6	6	6	6	8	16	16	16
	100							1.6	2.5			1.6	2.5	4	4	4	4	6	8	16	16
125							1.6	2.5			1.6	2.5	4	4	4	4	6	8	16	16	16
DPX 160 DPX 250 ER (25, 36 kA)	63						1	1.6	2.5		1	1.6	2.5	4	5	6.3	8	16	16	16	
	100							1.6	2.5			1.6	2.5	2.5	3.2	4	5	6.3	16	16	16
	160								2.5				2.5	2.5	3.2	4	5	6.3	16	16	16
	250													3.2	4	5	6.3	16	16	16	
DPX 160 DPX 250ER (50 kA)	40				0.63	1	1.6	2.5	0.63	1	1.6	2.5	2.5	3.2	4	5	6.3	16	16	16	
	63					1	1.6	2.5		1	1.6	2.5	2.5	3.2	4	5	6.3	16	16	16	
	100						1.6	2.5			1.6	2.5	2.5	3.2	4	5	6.3	16	16	16	
	160							2.5				2.5	2.5	3.2	4	5	6.3	16	16	16	
250													3.2	4	5	6.3	16	16	16		
DPX 250 DPX-H 250 DPX-L 250	40								0.63	1	1.6	2.5	2.5	3.2	4	5	6.3	16	16	16	
	63									1	1.6	2.5	2.5	3.2	4	5	6.3	16	16	16	
	100										1.6	2.5	2.5	3.2	4	5	6.3	16	16	16	
	160											2.5	2.5	3.2	4	5	6.3	16	16	16	
	250													3.2	4	5	6.3	16	16	16	
DPX 250 DPX-H 250 DPX-L 250 elec S1/S2 ⁽²⁾	40													3.2	4	5	6.3	16	16	16	
	100													3.2	4	5	6.3	16	16	16	
	160													3.2	4	5	6.3	16	16	16	
	250													3.2	4	5	6.3	16	16	16	
DPX 630 DPX-H 630 DPX-L 630	250																	6.3	8	6	8
	400																	6.3	8	6	8
	500																		8	6	8
	630																			6	7.5
	630																			10	6
DPX 630 elec S1/S2 ⁽²⁾	250																				
	400																				
	630																				
DPX-H 630 DPX-L 630 elec S1/S2 ⁽²⁾	400																				
	630																				
DPX 1250 DPX-H 1250	800																			7.5	7.5
	1000																				7.5
	1250																				

(1) Standard factory setting of magnetic threshold I_m

(2) Selectivity low

Selectivity between protection devices (continued)

Electronic DPX (SEL: LOW) / DPX												
Upstream MCCB electronic SEL: LOW	DPX 250 S1/S2 DPX-H 250 S1/S2				DPX 630 DPX-H 630 S1/S2			DPX 1600 DPX-H 1600 S1	DPX 1600 DPX-H 1600 S2	DPX 1600 DPX-H 1600 S1/S2		
In (A)	40	100	160	250	250	400	630	800	800	1250	1600	
I _{st} ⁽¹⁾ (kA)	3.5	3.5	3.5	3.5	5	5	5	10	10	15	20	
Downstream MCCB												
DPX 125 (16 kA)	16	3.5	3.5	3.5	3.5	8	8	8	T	T	T	T
	25	3.5	3.5	3.5	3.5	8	8	8	T	T	T	T
	40		3.5	3.5	3.5	6	6	6	T	T	T	T
	63		3.5	3.5	3.5	6	6	6	T	T	T	T
	100			3.5	3.5	6	6	6	T	T	T	T
	125			3.5	3.5	6	6	6	T	T	T	T
DPX 125 (25 kA)	16	3.5	3.5	3.5	3.5	8	8	8	T	T	T	T
	25	3.5	3.5	3.5	3.5	8	8	8	T	T	T	T
	40		3.5	3.5	3.5	6	6	6	T	T	T	T
	63		3.5	3.5	3.5	6	6	6	T	T	T	T
	100			3.5	3.5	6	6	6	T	T	T	T
	125			3.5	3.5	6	6	6	T	T	T	T
DPX 125 (36 kA)	16	3.5	3.5	3.5	3.5	8	8	8	25	T	T	T
	25	3.5	3.5	3.5	3.5	8	8	8	25	T	T	T
	40		3.5	3.5	3.5	6	6	6	25	T	T	T
	63		3.5	3.5	3.5	6	6	6	25	T	T	T
	100			3.5	3.5	6	6	6	25	T	T	T
	125			3.5	3.5	6	6	6	25	T	T	T
DPX 160 DPX 250ER (25 kA)	63		3.5	3.5	3.5	6	6	6	20	T	T	T
	100			3.5	3.5	6	6	6	20	T	T	T
	160				3.5	6	6	6	20	T	T	T
	250					6	6	6	20	T	T	T
DPX 160 DPX 250ER (36 kA)	63		3.5	3.5	3.5	6	6	6	20	T	T	T
	100			3.5	3.5	6	6	6	20	T	T	T
	160				3.5	6	6	6	20	T	T	T
	250			3.5	3.5		6	6	20	T	T	T
DPX 160 DPX 250ER (50 kA)	40		3.5	3.5	3.5	8	8	8	20	T	T	T
	63		3.5	3.5	3.5	6	6	6	20	T	T	T
	100			3.5	3.5	6	6	6	20	T	T	T
	160				3.5	6	6	6	20	T	T	T
DPX 250 (36 kA)	250						6	6	20	T	T	T
	40		3.5	3.5	3.5	8	8	8	20	T	T	T
	63		3.5	3.5	3.5	8	8	8	20	T	T	T
	100			3.5	3.5	8	8	8	20	T	T	T
	160				3.5	8	8	8	20	T	T	T
DPX 250 S1/S2 (36 kA)	40		1	1.6	2.5	8	8	8	20	T	T	T
	100			1.6	2.5	6	8	8	20	T	T	T
	160				2.5	6	8	8	20	T	T	T
	250					6	6	6	20	T	T	T

[1] Standard factory setting of magnetic threshold I_m

Electronic DPX (SEL: LOW) / DPX (continued)												
Upstream MCCB electronic SEL: LOW	DPX 250 S1/S2 DPX-H 250 S1/S2				DPX 630 DPX-H 630 S1/S2			DPX 1600 DPX-H 1600 S1	DPX 1600 DPX-H 1600 S2	DPX 1600 DPX-H 1600 S1/S2		
In (A)	40	100	160	250	250	400	630	800	800	1250	1600	
Ist ⁽¹⁾ (kA)	3.5	3.5	3.5	3.5	5	5	5	10	10	15	20	
Downstream MCCB												
DPX-H 250 (70 kA)	40	3.5	3.5	3.5	8	8	8	20	30	30	36	
	63	3.5	3.5	3.5	8	8	8	20	30	30	36	
	100		3.5	3.5	8	8	8	20	30	30	36	
	160			3.5	8	8	8	20	30	30	36	
	250					6	6	20	30	30	36	
DPX-H 250 S1/S2 (70 kA)	40	1	1.6	2.5	8	8	8	20	30	30	36	
	100		1.6	2.5	6	6	6	20	30	30	36	
	160			2.5	6	6	6	20	30	30	36	
	250					6	6	20	30	30	36	
DPX 630 (36 kA)	250					6	6	15	20	20	T	
	400						6	15	20	20	T	
	500							10	20	20	T	
	630							10	20	20	T	
DPX-H 630 (70 kA)	250					6	6	15	20	20	36	
	320					6	6	15	20	20	36	
	400						6	15	20	20	36	
	500							10	20	20	36	
	630							10	20	20	36	
DPX 630 S1/S2 (36 kA) ⁽²⁾	250					5	5	15	20	20	T	
	400						5	15	20	20	T	
	630							15	20	20	T	
DPX-H 630 S1/S2 (70 kA) ⁽²⁾	400						5	15	20	20	36	
	630							15	20	20	36	
DPX 1250 (50 kA)	800									20	20	
	1000									20	20	
	1250										20	
DPX-H 1250 (70 kA)	500							15	20	20	20	
	630							15	20	20	20	
	800									20	20	
	1000									20	20	
	1250										20	
DPX/DPX-H 1600 S1 (50/70 kA) ⁽²⁾	800									15	20	
DPX/DPX-H 1600 S2 (50/70 kA) ⁽²⁾	800									15	20	
DPX/DPX-H 1600 S1/S2 (50/70 kA) ⁽²⁾	1250										20	
	1600											

(1) Standard factory setting of magnetic threshold Im

(2) Selectivity low

Selectivity between protection devices (continued)

Electronic DPX (SEL: HIGH) / DPX												
Upstream MCCB electronic SEL: HIGH	DPX 250 S1/S2 DPX-H 250 S1/S2				DPX 630 DPX-H 630 S1/S2			DPX 1600 DPX-H 1600 S1	DPX 1600 DPX-H 1600 S2	DPX 1600 DPX-H 1600 S1/S2		
In (A)	40	100	160	250	250	400	630	800	800	1250	1600	
I _{st} ⁽¹⁾ (kA)	3.5	3.5	3.5	3.5	5	5	5	10	10	15	20	
Downstream MCCB												
DPX 125 (16 kA)	16	T	T	T	T	T	T	T	T	T	T	T
	25	T	T	T	T	T	T	T	T	T	T	T
	40		T	T	T	T	T	T	T	T	T	T
	63		T	T	T	T	T	T	T	T	T	T
	100			T	T	T	T	T	T	T	T	T
	125			T	T	T	T	T	T	T	T	T
DPX 125 (25 kA)	16	T	T	T	T	T	T	T	T	T	T	T
	25	T	T	T	T	T	T	T	T	T	T	T
	40		T	T	T	T	T	T	T	T	T	T
	63		T	T	T	T	T	T	T	T	T	T
	100			T	T	T	T	T	T	T	T	T
	125			T	T	T	T	T	T	T	T	T
DPX 125 (36 kA)	16	25	25	25	25	T	T	T	T	T	T	T
	25	25	25	25	25	T	T	T	T	T	T	T
	40		25	25	25	T	T	T	T	T	T	T
	63		25	25	25	T	T	T	T	T	T	T
	100			25	25	T	T	T	T	T	T	T
	125			25	25	T	T	T	T	T	T	T
DPX 160 DPX 250ER (25 kA)	63		25	25	25	T	T	T	T	T	T	T
	100			25	25	T	T	T	T	T	T	T
	160				25	T	T	T	T	T	T	T
	250					T	T	T	T	T	T	T
DPX 160 DPX 250ER (36 kA)	63		25	25	25	T	T	T	T	T	T	T
	100			25	25	T	T	T	T	T	T	T
	160				25	T	T	T	T	T	T	T
	250					T	T	T	T	T	T	T
DPX 160 DPX 250ER (50 kA)	40		25	25	25	36	36	36	36	36	36	36
	63		25	25	25	36	36	36	36	36	36	36
	100			25	25	36	36	36	36	36	36	36
	160				25	36	36	36	36	36	36	36
	250					36	36	36	36	36	36	36
DPX 250 (36 kA)	40		36	36	36	T	T	T	T	T	T	T
	63		36	36	36	T	T	T	T	T	T	T
	100			36	36	T	T	T	T	T	T	T
	160				36	T	T	T	T	T	T	T
	250					T	T	T	T	T	T	T
DPX 250 S1/S2 (36 kA)	40		T	T	T	T	T	T	T	T	T	T
	100			T	T	T	T	T	T	T	T	T
	160				T	T	T	T	T	T	T	T
	250					T	T	T	T	T	T	T

[1] Standard factory setting of magnetic threshold I_m

Electronic DPX (SEL: HIGH) / DPX (continued)												
Upstream MCCB electronic SEL: HIGH	DPX 250 S1/S2 DPX-H 250 S1/S2				DPX 630 DPX-H 630 S1/S2			DPX 1600 DPX-H 1600 S1	DPX 1600 DPX-H 1600 S2	DPX 1600 DPX-H 1600 S1/S2		
In (A)	40	100	160	250	250	400	630	800	800	1250	1600	
Ist ⁽¹⁾ (kA)	3.5	3.5	3.5	3.5	5	5	5	10	10	15	20	
Downstream MCCB												
DPX-H 250 (70 kA)	40		36	36	36	36	36	36	36	36	36	
	63		36	36	36	36	36	36	36	36	36	
	100			36	36	36	36	36	36	36	36	
	160				36	36	36	36	36	36	36	
	250					36	36	36	36	36	36	
DPX-H 250 S1/S2 (70 kA)	40				36	36	36	36	36	36	36	
	100				36	36	36	36	36	36	36	
	160				36	36	36	36	36	36	36	
	250					36	36	36	36	36	36	
DPX 630 (36 kA)	250							T	T	T	T	
	400							T	T	T	T	
	500							T	T	T	T	
	630							T	T	T	T	
DPX-H 630 (70 kA)	250					25	25	36	36	36	36	
	320					25	25	36	36	36	36	
	400						25	36	36	36	36	
	500						25	36	36	36	36	
	630							36	36	36	36	
DPX-H 630 S1/S2 (36 kA) ⁽²⁾	250							T	T ⁽²⁾	T ⁽²⁾	T ⁽²⁾	
	400							T	T ⁽²⁾	T ⁽²⁾	T ⁽²⁾	
	630							T	T ⁽²⁾	T ⁽²⁾	T ⁽²⁾	
DPX 630 S1/S2 (70 kA) ⁽²⁾	400					25		36	36 ⁽²⁾	36 ⁽²⁾	36 ⁽²⁾	
	630							36	36 ⁽²⁾	36 ⁽²⁾	36 ⁽²⁾	
DPX 1250 (50 kA)	800									36	36	
	1000									36	36	
	1250										36	
DPX-H 1250 (70 kA)	500							36	36	36	36	
	630							36	36	36	36	
	800									36	36	
	1000									36	36	
	1250										36	
DPX/DPX-H 1600 S1 (50/70 kA) ⁽²⁾	800									36	36	
DPX/DPX-H 1600 S2 (50/70 kA) ⁽²⁾	800									36 ⁽²⁾	36 ⁽²⁾	
DPX/DPX-H 1600 S1/S2 (50/70 kA) ⁽²⁾	1250										36 ⁽²⁾	
	1600											

(1) Standard factory setting of magnetic threshold Im

(2) Selectivity low

Selectivity between protection devices (continued)

MCCBs / MCBs													
		Upstream MCCBs											
		DPX 125 (16/25/36 kA)						DPX 160 (25/36/50 kA)			DPX 250 ER (25/36/50 kA)		
Downstream MCBs	In	16 A	25 A	40 A	63 A	100 A	125 A	63 A	100 A	160 A	100 A	160 A	250 A
LR 6000 DX 6000 6 kA DX 6000 10 kA DX-H 10 000 - 25 kA⁽¹⁾ B and C curves	1 A	T	T	T	T	T	T	T	T	T	T	T	T
	2 A	T	T	T	T	T	T	T	T	T	T	T	T
	3 A	T	T	T	T	T	T	T	T	T	T	T	T
	4 A	T	T	T	T	T	T	T	T	T	T	T	T
	6 A	6000	6000	6000	6000	T	T	T	T	T	T	T	T
	10 A	5000	5000	5000	5000	7500	7500	7500	7000	T	T	T	T
	16 A		4000	4000	4000	6000	6000	6000	6000	T	T	T	T
	20 A		3000	3000	3000	5000	5000	5000	5000	T	8000	T	T
	25 A			3000	3000	4500	4000	4500	4500	8500	6000	8500	T
	32 A				2000	4000	4000	4000	4000	7000	5000	7000	T
	40 A				2000	3000	3000	3000	3000	6000	4000	6000	T
	50 A					3000	3000	3000	3000	5500	4000	5500	7000
	63 A					3000	3000	3000	3000	5000	3000	5000	6000
80 A						2000	2000	2000	5000	2500	5000	6000	
100 A									4000		4000	5000	
125 A									2000		2000	3000	
DX 6000 D curve	1 A			T	T	T	T	T	T	T	T	T	T
	2 A			T	T	T	T	T	T	T	T	T	T
	3 A			T	T	T	T	T	T	T	T	T	T
	6 A			6000	6000	T	T	T	T	T	T	T	T
	10 A			5000	5000	7500	7500	7500	7500	T	T	T	T
	16 A			4000	4000	6000	6000	6000	6000	T	6000	T	T
	20 A			3000	3000	5000	5000	5000	5000	T	6000	T	T
	25 A			3000	3000	4500	4500	4500	4500	8500	5500	8500	T
	32 A				2000	4000	4000	4000	4000	7000	4500	7000	T
	40 A				2000	3000	3000	3000	3000	6000	4500	6000	T
	50 A					3000	3000	3000	3000	5500	3500	5500	T
	63 A					3000	3000	3000	3000	5000	3500	5000	6000
	80 A						1500			4000		4000	5000
100 A									3000		3000	4000	
125 A									1500		1500	2000	
DX-L 50 kA C curve	10 A							T	T	T	T	T	T
	16 A							T	T	T	T	T	T
	20 A							20000	20000	T	22000	T	T
	25 A							15000	15000	T	18000	T	T
	32 A							10000	10000	20000	13000	T	T
	40 A							7000	7000	17000	8000	20000	20000
	50 A							3000	3000	8000	4000	10000	20000
63 A							3000	3000	8000	4000	10000	15000	

(1) For breaking capacity of DX-H MCBs, according to IEC 60947-2

	DPX 250 (36 kA) DPX-H 250 (70 kA)				DPX 630 (36 kA) DPX-H 630 (70 kA)			DPX 1250/1600 (50 kA) DPX-H 1250/1600 (70 kA)			
	40 A	63 A	100 A	160 A	250 A	250 A	400 A	630 A	800 A	1000 A	1250 A
	T	T	T	T	T	T	T	T	T	T	T
	T	T	T	T	T	T	T	T	T	T	T
	T	T	T	T	T	T	T	T	T	T	T
	T	T	T	T	T	T	T	T	T	T	T
	6000	6000	T	T	T	T	T	T	T	T	T
	5000	5000	T	T	T	T	T	T	T	T	T
	4000	4000	T	T	T	T	T	T	T	T	T
	4000	4000	8000	T	T	T	T	T	T	T	T
	3000	3000	6000	T	T	T	T	T	T	T	T
		2000	5000	T	T	T	T	T	T	T	T
			5000	T	T	T	T	T	T	T	T
			4000	8000	T	T	T	T	T	T	T
			4000	8000	T	T	T	T	T	T	T
				8000	T	T	T	T	T	T	T
				7500	T	T	T	T	T	T	T
				3000	8000	T	T	T	T	T	T
		T	T	T	T	T	T	T	T	T	T
		T	T	T	T	T	T	T	T	T	T
		T	T	T	T	T	T	T	T	T	T
		6000	T	T	T	T	T	T	T	T	T
		5000	T	T	T	T	T	T	T	T	T
		4000	T	T	T	T	T	T	T	T	T
		4000	8000	T	T	T	T	T	T	T	T
		3000	6000	T	T	T	T	T	T	T	T
		2000	5000	T	T	T	T	T	T	T	T
		2000	5000	T	T	T	T	T	T	T	T
			4000	8000	T	T	T	T	T	T	T
			4000	8000	T	T	T	T	T	T	T
				7000	T	T	T	T	T	T	T
				6500	T	T	T	T	T	T	T
				2000	7000	T	T	T	T	T	T
		T	T	T	T	T	T	T	T	T	T
			40000	T	T	T	T	T	T	T	T
			33000	T	T	T	T	T	T	T	T
			28000	T	T	T	T	T	T	T	T
			20000	T	T	T	T	T	T	T	T
			13000	T	T	T	T	T	T	T	T
			8000	20000	T	T	T	T	T	T	T
			8000	20000	T	T	T	T	T	T	T

Fuses / MCCBs			
Downstream MCCBs	Upstream fuses gG type		
	250 A	400 A	1000 A
DPX 125	7500		
DPX 160		10 000	
DPX 250 ER		10 000	
DPX 250		10 000	
DPX 630			50 000

Choice of products



286 56

DMX³ ACBs and DMX³-I TRIP-FREE SWITCHES

	DMX ³ -N 2500 - 4000				DMX ³ -H 2500 - 4000				DMX ³ -L 2500 - 4000				
Icu (400 V AC)	50 kA				70 kA				100 kA				
Version	Fixed		Draw-out		Fixed		Draw-out		Fixed		Draw-out		
Poles	3P	4P	3P	4P	3P	4P	3P	4P	3P	4P	3P	4P	
In (A)	800	286 21	286 31	287 21	287 31	286 41	286 51	287 41	287 51	286 61	286 71	287 61	287 71
	1000	286 22	286 32	287 22	287 32	286 42	286 52	287 42	287 52	286 62	286 72	287 62	287 72
	1250	286 23	286 33	287 23	287 33	286 43	286 53	287 43	287 53	286 63	286 73	287 63	287 73
	1600	286 24	286 34	287 24	287 34	286 44	286 54	287 44	287 54	286 64	286 74	287 64	287 74
	2000	286 25	286 35	287 25	287 35	286 45	286 55	287 45	287 55	286 65	286 75	287 65	287 75
	2500	286 26	286 36	287 26	287 36	286 46	286 56	287 46	287 56	286 66	286 76	287 66	287 76
	3200	286 27	286 37	287 27	287 37	286 47	286 57	287 47	287 57	286 67	286 77	287 67	287 77
	4000	286 28	286 38	287 28	287 38	286 48	286 58	287 48	287 58	286 68	286 78	287 68	287 78

Electronic protection units and accessories

Electronic protection units			Communication module	12 V dc external power supply	Earth leakage module	External coil for earth leakage module	Module programmable output
MP4 LI	MP4 LSI	MP4 LSIg					
288 00	288 01	288 02	288 05	288 06	288 07	288 11	288 12

DMX³-I 2500 - 4000

Version	Fixed		Draw-out		
Poles	3P	4P	3P	4P	
In (A)	1250	286 83	286 93	287 83	287 93
	1600	286 84	286 94	287 84	287 94
	2000	286 85	286 95	287 85	287 95
	2500	286 86	286 96	287 86	287 96
	3200	286 87	286 97	287 87	287 97
	4000	286 88	286 98	287 88	287 98

Conversion of a fixed device into a draw-out device

Device	DMX ³ /DMX ³ -I 2500		DMX ³ /DMX ³ -I 4000	
Poles	3P	4P	3P	4P
Base for draw-out device	289 02	289 03	289 04	289 05
Transformation kit	289 09	289 10	289 11	289 12



287 56



288 51



288 37



288 82



288 96

Control auxiliaries

Supply	Shunt trips	Undervoltage releases	Delayed undervoltage releases	Motor operators	Closing coils
24 V AC/DC	288 48	288 55		288 34	288 41
48 V AC/DC	288 49	288 56		288 35	288 42
110 V AC/DC	288 50	288 57	288 62	288 36	288 43
230 V AC/DC	288 51	288 58	288 63	288 37	288 44
415 V AC	288 52	288 59		288 38	288 45
440 V AC	288 53	288 60		288 39	288 46
480 V AC	288 54	288 61		288 40	288 47

Locking options

	Key locking in "open" position	Key locking in "draw-out" position	Door locking	Padlocking in "open" position
Ronis lock	288 30	288 33		
Profalux lock	288 31	288 32		
2 hole support frame for above locks	288 28			
Left-hand and right-hand side mounting			288 20	
Padlocking system for ACBs				288 21
Padlocking system for safety shutters				288 26

Equipment for supply invertors

	Interlocking mechanism	Interlocking cable						Automation control unit	
		Type 1	Type 2	Type 3	Type 4	Type 5	Type 6	Standard	Communicating
DMX ³ 2500	288 64	289 20	289 21	289 21	289 21	289 21	289 21	261 93	261 94
DMX ³ 4000	288 65								

Accessories for connexion with bars

Accessories	Connexion	DMX ³ 2500				DMX ³ 4000			
		Fixed version		Draw-out version		Fixed version		Draw-out version	
		3P	4P	3P	4P	3P	4P	3P	4P
Rear terminals	Flat	288 84	288 85			288 92	288 93		
	Vertical	288 82	288 83	288 96	288 97			288 94	288 95
	Horizontal			288 96	288 97			288 94	288 95
Spreaders	Flat	288 86	288 87			288 86	288 87		
	Vertical	288 88	288 89			288 88	288 89		
	Horizontal	288 90	288 91			288 90	288 91		



6261 29



6261 17

DMX-E AIR CIRCUIT BREAKERS

		DMX-E 55				DMX-E 65			
Icu (415 V AC)		55 kA				65 kA			
Version		Fixed		Draw-out		Fixed		Draw-out	
Poles		3P	4P	3P	4P	3P	4P	3P	4P
In (A)	800	6260 02	6260 12	6260 22	6260 32	6260 42	6260 52	6260 62	6260 72
	1000	6260 03	6260 13	6260 23	6260 33	6260 43	6260 53	6260 63	6260 73
	1250	6260 04	6260 14	6260 24	6260 34	6260 44	6260 54	6260 64	6260 74
	1600	6260 05	6260 15	6260 25	6260 35	6260 45	6260 55	6260 65	6260 75
	2000					6260 46	6260 56	6260 66	6260 76
	2500					6260 47	6260 57	6260 67	6260 77

		DMX-E 80				DMX-E 100			
Icu (415 V AC)		80 kA				100 kA			
Version		Fixed		Draw-out		Fixed		Draw-out	
Poles		3P	4P	3P	4P	3P	4P	3P	4P
In (A)	2000	6260 86	6260 96	6261 06	6261 16	6261 26	6261 36	6261 46	6261 56
	2500	6260 87	6260 97	6261 07	6261 17	6261 27	6261 37	6261 47	6261 57
	3200	6260 88	6260 98	6261 08	6261 18	6261 28	6261 38	6261 48	6261 58
	4000	6260 89	6260 99	6261 09	6261 19	6261 29	6261 39	6261 49	6261 59

Conversion of a fixed device into a draw-out device

In	Bases for draw-out device								Rear terminals (supplied singly)	
	DMX-E 55		DMX-E 65		DMX-E 80		DMX-E 100		Horizontal	Vertical
	3P	4P	3P	4P	3P	4P	3P	4P		
800 to 1600 A	6263 86	6263 87	6263 86	6263 87					6263 30	6263 30
2000 and 2500 A			6263 88	6263 89	6263 88	6263 89	6263 90	6263 91	6263 31	6263 32
3200 and 4000 A					6263 90	6263 91	6263 90	6263 91	6263 30	6263 30

Interlocking mechanism for supply invertors

1 standard power supply + 1 standby power supply	3 power supplies	2 standard power supplies + 1 standby power supply	2 standard power supplies + 1 coupler
6263 80	6263 81	6263 82	6263 83



6263 04



6262 95

Control auxiliaries

Supply		Shunt trips	Undervoltage releases	Delayed undervoltage releases	Motor operators	Closing coils
DC	24/30 V	6262 60	6262 70		6262 91	6263 00
	48 V		6262 71	6262 81	6262 92	6263 01
	60 V				6262 92	6263 01
	110 V	6262 62	6262 74	6262 84	6262 93	6263 02
	125 V				6262 93	
	220 V	6262 64				6263 04
	250 V	6262 64			6262 95	6263 04
AC 50 Hz	400 V				6262 96	
	110 V	6262 62	6262 72	6262 82	6262 93	6263 02
	220 V	6262 64				
	240 V	6262 64	6262 77	6262 87	6262 95	6263 04
	250 V					
	380 V		6262 79	6262 89	6262 96	
AC 60 Hz	415 V	6262 65	6262 79	6262 89	6262 96	6263 05
	110 V	6262 62	6262 73	6262 83	6262 93	6263 02
	220 V	6262 64				6263 04
	240 V	6262 64	6262 78	6262 88	6262 95	6263 04
	380/415 V	6262 65	6262 80	6262 90	6262 96	6263 05

Signalling auxiliaries

Position signal contact	Fault signal contact	True "ready to close" contact	Shunt release action signal contact	Undervoltage release action signal contact
6263 11	6263 17	6263 18	6263 15	6263 16

Locking options

For lock (not supplied)	Key locking in "open" position	Key locking in "draw-out" position	Door locking
Ronis	6263 40	6263 45	
Profalux	6263 41	6263 46	
Castell	6263 42	6263 47	
Kirk	6263 43	6263 48	
None			6263 22

Accessories

Rating mis-insertion device	Operation counter	Test box
6263 20	6263 24	6263 79



250 18



250 59



254 23

DPX CIRCUIT BREAKERS AND DPX-I TRIP-FREE SWITCHES

DPX-E 125 and DPX 125

Icu (400 V)*	16 kA				25 kA		36 kA			
Poles	1P	3P	3P + ½ N	4P	3P	4P	3P	3P + ½ N	4P	
In (A)	16	250 00	250 16		250 24	250 36	250 44	250 50		250 58
	20	250 01								
	25	250 02	250 17		250 25	250 37	250 45	250 51		250 59
	32	250 03								
	40	250 04	250 18		250 26	250 38	250 46	250 52		250 60
	50	250 05								
	63	250 06	250 19		250 27	250 39	250 47	250 53		250 61
	80	250 07								
	100	250 08	250 20		250 28	250 40	250 48	250 54		250 62
	125	250 09	250 21	250 23	250 29	250 41	250 49	250 55	250 57	250 63

* 230 V for 1P devices

DPX 160

Icu (400 V)	25 kA			36 kA			50 kA		
Poles	3P	3P + ½ N	4P	3P	3P + ½ N	4P	3P	3P + ½ N	4P
In (A)	40						251 62		251 70
	63	251 23		251 31	251 49		251 57	251 63	251 71
	100	251 24		251 32	251 50		251 58	251 64	251 72
	160	251 25	251 27	251 33	251 51	251 53	251 59	251 65	251 67

DPX 250 ER

Icu (400 V)	25 kA			36 kA			50 kA			
Poles	3P	3P + ½ N	4P	3P	3P + ½ N	4P	3P	3P + ½ N	4P	
In (A)	100	252 04		252 14	252 24		252 34	252 44		252 54
	160	252 05		252 15	252 25		252 35	252 45		252 55
	250	252 06	252 09	252 16	252 26	252 29	252 36	252 46	252 49	252 56

DPX 250

Release	Thermal magnetic						Electronic				
Icu (400 V)	36 kA			70 kA			36 kA		70 kA		
Poles	3P	3P + ½ N	4P	3P	3P + ½ N	4P	3P	4P	3P	4P	
In (A)	40	253 28		253 45	253 52		253 69	254 01	254 07	254 13	254 19
	63	253 29		253 46	253 53		253 70				
	100	253 30		253 47	253 54		253 71	254 03	254 09	254 15	254 21
	160	253 31	253 41	253 48	253 55		253 72	254 04	254 10	254 16	254 22
	250	253 32	253 42	253 49	253 56	253 66	253 73	254 05	254 11	254 17	254 23



256 32



257 32

DPX 630

Release	Thermal magnetic						Electronic				
Icu (400 V)	36 kA			70 kA			36 kA		70 kA		
Poles	3P	3P + ½N	4P	3P	3P + ½ N	4P	3P	4P	3P	4P	
In (A)	250	255 21		255 36			256 01	256 05			
	320	255 22	255 32	255 37	255 42	255 52	255 57				
	400	255 23	255 33	255 38	255 43	255 53	255 58	256 02	256 06	256 10	256 14
	500	255 25	255 35	255 39	255 45	255 55	255 59				
	630	255 24	255 34	255 40	255 44	255 54	255 60	256 03	256 07	256 11	256 15

DPX 1250 - 1600

Release	Thermal magnetic				Electronic S1				Electronic S2				
Icu (400 V)	50 kA		70 kA		50 kA		70 kA		50 kA		70 kA		
Poles	3P	4P	3P	4P	3P	4P	3P	4P	3P	4P	3P	4P	
In (A)	800	258 02	258 09	258 16	258 23	257 02	257 06	257 10	257 14	257 26	257 30	257 34	257 38
	1000	258 03	258 10	258 17	258 24								
	1250	258 04	258 11	258 18	258 25	257 03	257 07	257 11	257 15	257 27	257 31	257 35	257 39
	1600					257 04	257 08	257 12	257 16	257 28	257 32	257 36	257 40

Electronic earth leakage modules for DPX (Adjustable sensitivity: 0.03 - 0.3 - 1 - 3 A)

Device	In (A)	3-pole		4-pole	
		mounted side by side	mounted underneath	mounted side by side	mounted underneath
DPX 125	63	260 02		260 03	260 04
	125	260 12		260 13	260 14
DPX 160	160	260 20		260 21	260 22
	160			260 31	260 33
DPX 250 ER	250			260 36	260 38
	160				260 51
DPX 250	250		260 54		260 55
	400		260 60		260 61 260 63 ⁽¹⁾
DPX 630	630		260 64		260 65 260 67 ⁽¹⁾



253 99



265 32

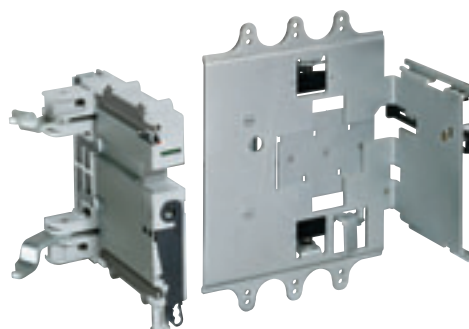

265 46

DPX-I trip-free switches

In (A)	DPX-I 125		DPX-I 160		DPX-I 250 ER		DPX-I 250		DPX-I 630		DPX-I 1600	
	3P	4P	3P	4P	3P	4P	3P	4P	3P	4P	3P	4P
125	250 98	250 99										
160			251 98	251 99								
250					252 98	252 99	253 98	253 99				
400									255 86	255 87		
630									255 88	255 89		
800											257 94	257 95
1250											257 96	257 97
1600											257 98	257 99

Equipment and accessories for plug-in and draw-out version

Devices		DPX 250 ER		DPX 250			DPX 630			DPX 1600		
		3P	4P	3P	4P	4P + earth leakage module	3P	4P	4P + earth leakage module	3P	4P	
Fixed version to plug-in version	Tulip contacts	265 12	265 13	265 29	265 30		265 50	265 51				
	Front terminal mounting base	265 14	265 15	265 31	265 32	265 37	265 52	265 53	265 58			
	Rear terminal mounting base	265 16	265 17	265 33	265 34	265 38	265 54	265 55	265 59			
	Flat rear terminal mounting base			265 35	265 36	265 39	265 56	265 57	265 60			
Fixed version to draw-out version (mounting base + tulip contacts + "Debro-lift" mechanism)	Front terminal									265 82	265 83	
	Rear terminal									265 84	265 85	
Plug-in version to draw-out version ("Debro-lift" mechanism)				265 45	265 46	265 47	265 66	265 67	265 68			
Set of connectors (6 pins)					098 19							
Set of connectors (8 pins)			263 99		263 99				263 99			
Extractor handles (set of 2)					263 43				263 68			
Isolated handle for drawing-out					265 75				265 75		265 75	
Signalling contact plugged-in/drawn-out					265 74				265 74		265 74	
Key lock for "Debro-lift" mechanism	DPX only				265 76				265 76		265 76	
	motorised DPX or rotary handle				265 78				265 78		265 80	



262 50 262 11 262 79 261 73 261 90

Accessories, rotary and motor driven handles

		DPX 125 DPX-I 125	DPX 160 DPX-I 160	DPX 250 ER	DPX 250	DPX 630	DPX 1600
Sealable terminal shields	3P	262 05	262 15	262 85	262 26/28 ⁽¹⁾	262 44	262 64
	4P	262 06	262 16	262 86	262 27/29 ⁽¹⁾	262 45	262 65
Insulated shield	set of 3				262 30	262 30	262 66
Padlocking accessory		262 00	262 10	262 10	262 21	262 40	262 60
Cage terminal		Supplied	262 18	262 88	262 35	262 50	262 69
High capacity cage terminal			262 19			262 51	262 70
Adaptator for lug					262 31	262 46	
Extended front terminals			262 17		262 32	262 47	262 67/68 ⁽²⁾
Spreaders	3P			262 90	262 33	262 48	262 73
	4P			262 91	262 34	262 49	262 74
Swivel rear terminals	3P	263 00	263 10	265 10	263 31	263 50	
	4P	263 01	263 11	265 11	263 32	263 51	
Flat rear terminals	3P				265 27	263 52	263 80/81 ⁽³⁾
	4P				265 28	263 53	263 82/83 ⁽³⁾
Direct rotary handle	standard	262 01	262 11	262 11	262 22	262 41	262 61
	for emergency use	262 03	262 13	262 13	262 24 ⁽⁴⁾	262 24 ⁽⁴⁾	
	Eurolocks locking accessory	262 25	262 25	262 25		262 25	262 25
Vari-depth handle	standard	262 75	262 77	262 77	262 79	262 81	262 83
	for emergency use	262 76	262 78	262 78	262 80 ⁽⁴⁾	262 82 ⁽⁴⁾	262 84
	Eurolocks locking accessory	262 92	262 92	262 92	262 92	262 92	262 92
	Profalux locking accessory	262 93	262 93	262 93	262 93	262 93	262 93
	Ronis locking accessory	262 94	262 94	262 94	262 94	262 94	262 94
Motor driven handle	24 V				261 30	261 40	
	230 V				261 34	261 44	261 54
	Ronis locking accessory				261 59	261 59	261 59

Auxiliaries

Supply	Auxiliary contact or fault signal	Shunt releases	Undervoltage releases		Time lag undervoltage releases		
			for DPX 125, DPX-IS 250/630	for DPX 160 to DPX 1600, DX-IS 1600, DPX-I	Time lag module	Release for DPX-IS, DPX 125/630	Releases for DPX 250 ER to DPX 1600
	261 60					261 75	261 85
24 V AC		261 64	261 70	261 80			
24 V DC		261 64	261 71	261 81			
48 V AC		261 65					
48 V DC		261 65	261 72	261 82			
110 V AC		261 66	261 76	261 86			
110 V DC		261 66					
230 V AC		261 67	261 73	261 83	261 90		
230 V DC		261 67					
400 V AC		261 68	261 74	261 84	261 91		
400 V DC		261 68					

(1) Long/short | (2) In ≤ 1250 A: Cat.No 262 67 - In = 1600 A: Cat.No 262 68 | (3) Short/long
 (4) To be fit on Cat.No 262 22

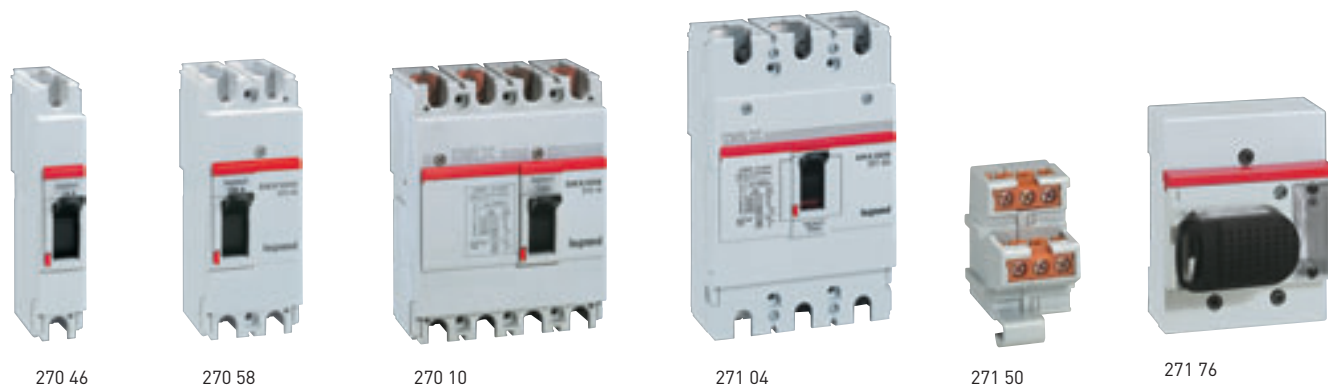

DRX CIRCUIT BREAKERS

DRX 100

Icu (415 V)	10 kA		20 kA		25 kA	35 kA			
Poles	3P	4P	3P	4P	1P	2P	3P	4P	
In (A)	15	270 00	270 10	270 20	270 30	270 40	270 50	270 60	270 70
	20	270 01	270 11	270 21	270 31	270 41	270 51	270 61	270 71
	25	270 02	270 12	270 22	270 32	270 42	270 52	270 62	270 72
	30	270 03	270 13	270 23	270 33	270 43	270 53	270 63	270 73
	40	270 04	270 14	270 24	270 34	270 44	270 54	270 64	270 74
	50	270 05	270 15	270 25	270 35	270 45	270 55	270 65	270 75
	60	270 06	270 16	270 26	270 36	270 46	270 56	270 66	270 76
	75	270 07	270 17	270 27	270 37	270 47	270 57	270 67	270 77
100	270 08	270 18	270 28	270 38	270 48	270 58	270 68	270 78	

DRX 250

Icu (415 V)	18 kA		25 kA		36 kA		
Poles	3P	4P	3P	4P	3P	4P	
In (A)	125	271 00	271 06	271 12	271 18	271 24	271 30
	150	271 01	271 07	271 13	271 19	271 25	271 31
	175	271 02	271 08	271 14	271 20	271 26	271 32
	200	271 03	271 09	271 15	271 21	271 27	271 33
	225	271 04	271 10	271 16	271 22	271 28	271 34

Electrical accessories

Supply	Auxiliary contact bloc			Shunt trips	Undervoltage releases
	with 1 auxiliary	with 1 alarm	with 1 auxiliary + 1 alarm		
Up to 250 V AC/DC	271 40	271 41	271 42		
12 V AC/DC				271 50	271 60
24 V AC/DC				271 51	271 61
48 V AC/DC				271 52	271 62
110/130 V AC				271 53	271 63
200/240 V AC				271 54	271 64
277 V AC				271 54	271 67
380/415 V AC				271 55	271 65
440/480 V AC				271 55	271 66

Connection accessories, padlocking and rotary handles

Device	DRX 100			DRX 250	
Poles	2P	3P	4P	3P	4P
Insulating shields		271 81	271 82	271 81	271 82
Seasable terminal shields	271 91	271 83	271 84	271 85	271 86
Cage terminal*	Up to 50 A	271 70	271 72		
	from 60 to 100 A	271 71	271 73		
	Up to 250 A			271 74	271 75
Padlocking system (up to 3 padlocks)		271 80		271 81	
	Direct on DRX	271 76		271 78	
Rotary handle		271 77		271 79	
		Vari-depth handle			

* Available by set of 60 pieces: Cat.No 271 92 (up to 50 A), Cat.No 271 93 (60 to 100 A), Cat.No 271 94 (up to 250 A)



6062 02



6027 10

DX LEXIC MCBs, RCDs AND RCBOs

MCBs DX 10 kA

Nominal rating (A)	B curve		C curve	
	1P	3P	1P	3P
6	6062 02	6062 24	6062 46	6062 68
10	6062 03	6062 25	6062 47	6062 69
16	6062 04	6062 26	6062 48	6062 70
20	6062 05	6062 27	6062 49	6062 71
25	6062 06	6062 28	6062 50	6062 72
32	6062 07	6062 29	6062 51	6062 73
40	6062 08	6062 30	6062 52	6062 74
50	6062 09	6062 31	6062 53	6062 75
63	6062 10	6062 32	6062 54	6062 76

MCBs DX $\overline{6000}$ - 10kA

Nominal rating (A)	B curve					C curve					
	1P	1P+N	2P	3P	3P+N	1P	1P+N	2P	3P	3P+N	4P
0.5	-	-	-	-	-	-	064 01	-	-	-	-
1	061 52	-	062 57	-	-	063 68	064 03	064 60	064 80	-	065 55
2	061 53	061 95	062 58	062 78	-	063 69	064 04	064 61	064 81	-	065 56
3	061 54	061 96	062 59	062 79	-	063 70	064 05	064 62	064 82	-	065 57
4	061 55	061 97	062 60	062 80	-	063 71	064 06	064 63	064 83	-	065 58
6	061 56	061 98	062 61	062 81	063 31	063 72	064 07	064 64	064 84	065 39	065 59
10	061 58	062 00	062 63	062 83	063 34	063 74	064 09	064 66	064 86	065 41	065 61
16	061 60	062 02	062 65	062 85	063 36	063 76	064 12	064 68	064 88	065 43	065 63
20	061 61	062 03	062 66	062 86	063 37	063 77	064 13	064 69	064 89	065 44	065 64
25	061 62	062 04	062 67	062 87	063 38	063 78	064 14	064 70	064 90	065 45	065 65
32	061 63	062 05	062 68	062 88	063 39	063 79	064 15	064 71	064 91	065 46	065 66
40	061 64	062 06	062 69	062 89	063 40	063 80	064 16	064 72	064 92	065 47	065 67
50	061 65	-	062 70	062 90	063 41	063 81	-	064 73	064 93	065 48	065 68
63	061 66	-	062 71	062 91	063 42	063 82	-	064 74	064 94	065 49	065 69



068 60



069 20

MCBs DX-H **10 000** - 25 kA - C curve

Nominal rating (A)	1P	1P+N	2P	3P	3P+N	4P
2	068 53	-	069 13	069 33	-	069 93
3	068 54	-	069 14	069 34	-	069 94
6	068 56	068 96	069 16	069 36	069 76	069 96
10	068 58	068 98	069 18	069 38	069 78	069 98
13	068 59	068 99	069 19	069 39	069 79	069 99
16	068 60	069 00	069 20	069 40	069 80	070 00
20	068 61	069 01	069 21	069 41	069 81	070 01
25	068 62	069 02	069 22	069 42	069 82	070 02
32	068 63	069 03	069 23	069 43	069 83	070 03
40	068 64	069 04	069 24	069 44	069 84	070 04
50	068 65	069 05	069 25	069 45	069 85	070 05
63	068 66	069 06	069 26	069 46	069 86	070 06
80	063 83	-	064 75	064 95	-	065 70
100	063 84	-	064 76	064 96	-	065 71
125	063 85	-	064 77	064 97	-	065 72

MCBs DX **6 000** - 15 kA - D curve

Nominal rating (A)	1P	2P	3P	4P
1	065 75	066 25	066 45	066 65
2	065 76	066 26	066 46	066 66
3	065 77	066 27	066 47	066 67
4	-	-	-	066 68
6	065 79	066 29	066 49	066 69
10	065 81	066 31	066 51	066 71
16	065 83	066 33	066 53	066 73
20	065 84	066 34	066 54	066 74
25	065 85	066 35	066 55	066 75
32	065 86	066 36	066 56	066 76
40	065 87	066 37	066 57	066 77
50	065 88	066 38	066 58	066 78
63	065 89	066 39	066 59	066 79
80	-	066 40	066 60	066 80
100	-	066 41	066 61	066 81
125	-	066 42	066 62	066 82

MCBs DX-L- 50 kA - C curve

Nominal rating (A)	2P	3P	4P
10	071 12	071 27	071 42
16	071 14	071 29	071 44
20	071 15	071 30	071 45
25	071 16	071 31	071 46
32	071 17	071 32	071 47
40	071 18	071 33	071 48
50	071 19	071 34	071 49
63	071 20	071 35	071 50

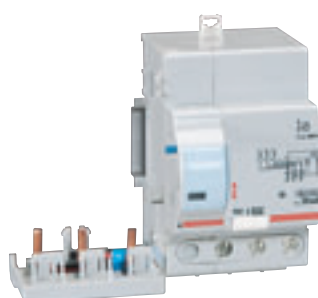

074 01

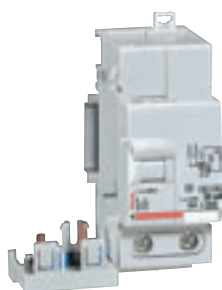

075 64

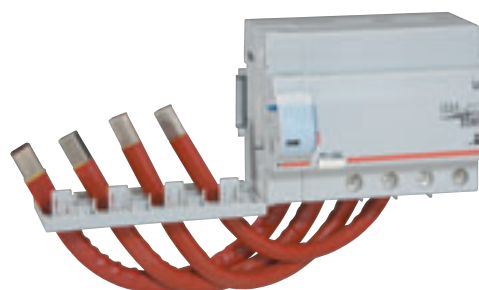

074 63

Add-on modules for DX, DX-H, DX D

Sensitivity	In (A)	AC type			A type			Hpi type		
		2-pole 230/400 V AC	3-pole 400 V AC	4-pole 400 V AC	2-pole 230/400 V AC	3-pole 400 V AC	4-pole 400 V AC	2-pole 230/400 V AC	3-pole 400 V AC	4-pole 400 V AC
30 mA	32	074 01	074 28	074 55	074 83		075 37			
	63	074 02	074 29	074 56	074 84	075 11	075 38	075 64	075 68	
	80-125	074 03		074 57	074 85		075 39		075 69	
300 mA	32	074 07	074 34	074 61	074 89		075 43			
	63	074 08	074 35	074 62	074 90	075 17	075 44			075 74
	80-125	074 09	074 36	074 63	074 91	075 18	075 45			
300 mA (s)	63	074 11	074 38	074 65	074 93	075 20	075 47			
	80-125			074 66						
1 A	63	074 23	074 01	074 77						
	80-125		074 01	074 78						

Add-on modules for DX-L

Sensitivity	Hpi type		
	2-pole - 230/400 V AC	3-pole - 400 V AC	4-pole - 400 V AC
30 mA	075 76	075 80	075 84
300 mA	075 77	075 81	075 85
300 mA (s)	075 78	075 82	075 86
1 A (s)	075 79	075 83	075 87

Auxiliaries and accessories

Signalling auxiliaries	Auxiliary changeover switch	073 50	
	Fault signalling changeover switch	073 51	
	Fault signalling + auxiliary changeover switch	073 54	
Shunt releases	12 to 48 V AC/DC	073 60	
	110 to 415 V AC - 110 to 125 V DC	073 61	
Undervoltage release	Time delay adjustable from 0 to 300 ms - 230 V DC	073 68	
Motor driven control module	For 2P RCDs, 1P+N and 2P RCBOs, 2P and 1 module 1P+N MCBs	073 80	
	For MCBs equipped with add-on modules and 2P, 3P, 4P RCBOs up to 63 A	073 73	
Automatic resetting module	To be connected to motor driven control Cat.No 073 73	073 83	
STOP&GO automatic resetting	Compatible with : 2P RCDs, 2P RCBOs, 2P MCBs ≤ 63 A	Standard	073 81
		Autotest	073 82



090 53



090 74



091 47

RCDs DX™

Sensitivity	In (A)	AC type			A type			Hpi type	
		2-pole 230 V AC	4-pole - 400 V AC		2-pole 230 V AC	4-pole - 400 V AC		2-pole 230 V AC	4-pole 400 V AC Neutral on right-hand side
			Neutral on right-hand side	Neutral on left-hand side		Neutral on right-hand side	Neutral on left-hand side		
10 mA	16	089 06	-	-	090 53	-	-	-	-
	25	089 09	089 93	086 93	090 56	091 40	090 98	088 22	6021 08
30 mA	40	089 10	089 94	086 94	090 57	091 41	090 99	088 23	6021 09
	63	089 11	089 95	086 95	090 58	091 42	091 00	088 24	6021 10
	80	089 12	089 96	-	090 59	091 43	-	-	-
	100	6027 10	-	-	-	091 44	-	-	-
100 mA	25	089 15	089 99	-	-	091 46	-	-	-
	40	089 16	090 00	-	-	091 47	-	-	-
	63	089 17	090 01	-	-	091 48	-	-	-
	80	089 18	090 02	-	-	091 49	-	-	-
	-	-	-	-	-	091 50	-	-	-
300 mA	25	089 27	090 11	-	090 74	091 58	-	-	-
	40	089 28	090 12	-	090 75	091 59	-	-	-
	63	089 29	090 13	-	090 76	091 60	-	-	-
	80	089 30	090 14	-	090 77	091 61	-	-	-
	100	6027 12	-	-	-	091 62	-	-	-
300 mA (s)	40	-	090 18	-	-	091 65	-	-	-
	63	-	090 19	-	-	091 66	-	-	-
500 mA	25	-	090 23	-	-	091 71	-	-	-
	40	-	090 24	-	-	091 72	-	-	-
	63	-	090 25	-	-	091 73	-	-	-
	80	-	090 26	-	-	091 74	-	-	-



6064 00



078 86



079 19

RCBOs DX™ 6 000 - 10 kA and DX™ 10 000

Sensitivity	In (A)	AC type				A type		
		Single pole - 230 V AC		Single pole + Neutral on right-hand side 230 V AC	2-pole 230 V AC	4-pole 400 V AC	Single pole + Neutral on right-hand side 230 V AC	4-pole 400 V AC
		Black neutral lead	Blue neutral lead					
10 mA	3	-	-	-	-	-	085 75	-
	10	-	-	078 79	077 45	-	-	-
	16	-	-	-	077 46	-	-	-
	20	-	-	-	077 47	-	-	-
30 mA	3	-	-	078 81	-	-	-	-
	6	-	-	078 83	-	-	085 79	-
	10	6064 00	6064 10	078 84	079 11	079 62	085 85	080 75
	16	6064 01	6064 11	078 86	079 19	079 64	085 87	080 76
	20	6064 02	6064 12	078 87	079 20	079 65	085 88	080 77
	25	6064 03	6064 13	078 88	079 21	079 66	085 89	080 78
	32	6064 04	6064 14	078 89	079 22	079 67	085 90	080 79
	40	-	-	078 90	079 29	080 13	085 91	-
	45	6064 05	6064 15	-	-	-	-	-
	50	-	-	-	079 30	080 14	-	-
63	-	-	-	079 31	080 15	-	-	
300 mA (s)	6	-	-	078 94	-	-	-	-
	10	-	-	078 95	079 44	079 75	-	080 84
	16	-	-	078 97	079 46	079 77	-	080 85
	20	-	-	078 98	079 47	079 78	-	080 86
	25	-	-	078 99	079 48	079 79	-	080 87
	32	-	-	079 00	079 49	079 80	-	080 88
	40	-	-	079 01	079 50	080 31	-	-
	50	-	-	-	079 51	080 32	-	-
63	-	-	-	079 52	080 33	-	-	

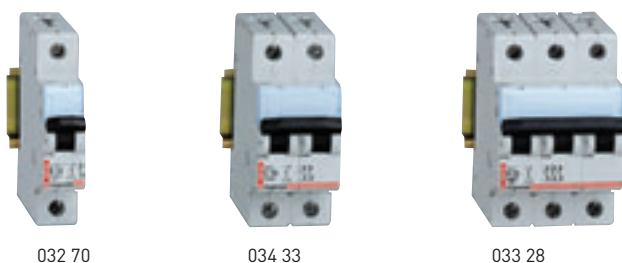

DX-E MCBs

MCBs DX-E 6 000 - 6kA								
Nominal rating (A)	B curve				C curve			
	1P	2P	3P	4P	1P	2P	3P	4P
6	032 66	033 08	033 22	033 68	033 82	034 29	034 47	034 89
10	032 68	033 10	033 24	033 70	033 84	034 31	034 49	034 91
13	032 69	033 11	033 25	033 71	033 85	034 32	034 50	034 92
16	032 70	033 12	033 26	033 72	033 86	034 33	034 51	034 93
20	032 71	033 13	033 27	033 73	033 87	034 34	034 52	034 94
25	032 72	033 14	033 28	033 74	033 88	034 35	034 53	034 95
32	032 73	033 15	033 29	033 75	033 89	034 36	034 54	034 96
40	032 74	033 16	033 30	033 76	033 90	034 37	034 55	034 97
50	032 75	033 17	033 31	033 77	033 91	034 38	034 56	034 98
63	032 76	033 18	033 32	033 78	033 92	034 39	034 57	034 99

LR MCBs and RCDs

MCBs LR 6 000 - 6kA									
Nominal rating (A)	B curve			C curve					
	1P	2P	3P	1P	1P+N	2P	3P	3P+N	4P
6	6049 02	6049 17	6049 32	6048 02	6048 90	6048 17	6048 32	6047 96	6048 47
10	6049 03	6049 18	6049 33	6048 03	6048 91	6048 18	6048 33	6048 94	6048 48
13	6049 04	6049 19	-	6048 04	6048 92	6048 19	6048 34	6048 95	-
16	6049 05	6049 20	6049 35	6048 05	6048 93	6048 20	6048 35	6048 96	6048 50
20	6049 06	6049 21	6049 36	6048 06	6047 90	6048 21	6048 36	6048 97	6048 51
25	6049 07	6049 22	6049 37	6048 07	6047 91	6048 22	6048 37	6048 98	6048 52
32	6049 08	6049 23	6049 38	6048 08	6047 92	6048 23	6048 38	6048 99	6048 53
40	6049 09	6049 24	6049 39	6048 09	-	6048 24	6048 39	6047 97	6048 54
50	6049 10	6049 25	6049 40	6048 10	-	6048 25	6048 40	6047 98	6048 55
63	6049 11	6049 26	6049 41	6048 11	-	6048 26	6048 41	6047 99	6048 56

RCDs LR™					
Sensitivity	In (A)	AC type		A type	
		2-pole - 230 V AC	4-pole - 400 V AC Neutral on right-hand side	2-pole - 230 V AC	4-pole - 400 V AC Neutral on right-hand side
30 mA	25	6021 36	6021 46	-	-
	40	6021 37	6021 47	6021 93	6021 94
	63	6021 38	-	-	6021 95
100 mA	25	6021 39	6021 49	-	-
	40	6021 40	6021 50	-	-
300 mA	25	6021 42	-	-	-
	40	6021 43	6021 52	-	-
	63	6021 44	6021 53	-	-



266 70



255 98



225 15

DPX-IS AND VISTOP ISOLATING SWITCHES

DPX-IS isolating switches

Model	In (A)	With release						Without release					
		Front handle		Right-hand side handle		Left-hand side handle		Front handle		Right-hand side handle		Left-hand side handle	
		3P	4P	3P	4P	3P	4P	3P	4P	3P	4P	3P	4P
DPX-IS 250	63	266 30	266 34	266 40	266 44	266 50	266 54						
	100	266 31	266 35	266 41	266 45	266 51	266 55						
	160	266 32	266 36	266 42	266 46	266 52	266 56	266 02	266 06	266 12	266 16	266 22	266 26
	250	266 33	266 37	266 43	266 47	266 53	266 57	266 03	266 07	266 13	266 17	266 23	266 27
DPX-IS 630	400	266 72	266 74	266 76	266 78	266 80	266 82	266 60	266 62	266 64	266 66	266 68	266 70
	630	266 73	266 75	266 77	266 79	266 81	266 83	266 61	266 63	266 65	266 67	266 69	266 71
DPX-IS 1600	800	265 91	265 95										
	1000	265 92	265 96										
	1250	265 93	265 97										
	1600	265 94	265 98										

Vistop isolating switches

Mounting	In (A)	Front handle			Side handle			Auxiliary contact for on/off signalling
		2 P	3 P	4 P	2 P	3 P	4 P	
On faceplate	32	224 98	225 00	225 02	225 03	225 05	225 07	227 07
On faceplate or rail	63		225 12	225 15		225 16	225 18	
	100		225 20	225 22		225 25	225 27	
	125		225 34	225 39		225 44	225 46	
	160		225 51	225 53		225 54	225 56	

Accessories

		DPX-IS 250	DPX-IS 630	DPX-IS 1600	Vistop 63 to 160 A
Direct handle for emergency use	front and right-hand side	266 89	266 89		
	left-hand side	266 90	266 90		
Vari-depth handle	for standard handle	266 86	266 86	265 89	
	for emergency handle	266 87	266 87	265 90	
Front external handle					227 32
Palock	Ronis	266 92	266 97		
Locking accessories for vari-depth handle	Euro locks			262 92	
	Profalux			262 93	
	Ronis			262 94	
Terminal shields	2P	262 87	262 45	262 64	
	3P			262 65	
Insulation shields				262 66	



215 36



216 01



133 08



153 96

SP FUSE CARRIERS AND CYLINDRICAL CARTRIDGE FUSES

SP fuse carriers

	1P	2P	3P	3P + equipped neutral	3P with changeover micro-switch
SP 51 for HRC fuses 14 x 51	215 01	215 03	215 04	215 05	215 36
SP 58 for HRC fuses 22 x 58	216 01		216 04	216 05	216 36
Link handle (300 mm)	216 96				

HRC cylindrical cartridge fuses type gG

Rating (A)	Size					
	10 x 38		14 x 51		22 x 58	
	Without indicator	With indicator	Without indicator	With indicator	Without indicator	With indicator
0.5	133 94					
1	133 01					
2	133 02	134 02				
3	133 03	134 03				
4	133 04	134 04				
6	133 06	134 06	143 06			
8	133 08	134 08				
10	133 10	134 10	143 10			
16	133 16	134 16	143 16	145 16	153 16	
20	133 20	134 20	143 20	145 20	153 20	
25	133 25	134 25	143 25	145 25	153 25	
32			143 32	145 32	153 32	
40			143 40	145 40	153 40	
50			143 50	145 50	153 50	155 50
63					153 63	155 63
80					153 80	155 80
100					153 96	155 96
125					153 97 ⁽¹⁾	155 97 ⁽¹⁾

(1) Overrating described by standards



120 04

130 08

140 12

151 50

Cylindrical cartridges fuse type aM

Rating (A)	Size					
	8.5 x 31.5	10 x 38 HRC	14 x 51 HRC		22 x 58 HRC	
	Without indicator	Without indicator	Without indicator	With indicator	Without indicator	With indicator
0.5		130 95				
1		130 01				
2		130 02		141 02		
4	120 04	130 04		141 04		
6	120 06	130 06		141 06		
8	120 08	130 08		141 08		
10	120 10	130 10	140 10	141 10		
12		130 12	140 12	141 12		
16		130 16	140 16	141 16		
20		130 20 ⁽²⁾	140 20	141 20		
25		130 25 ⁽²⁾	140 25	141 25	150 25	151 25
32			140 32	141 32	150 32	151 32
40			140 40	141 40	150 40	151 40
50			140 50 ⁽¹⁾	141 50 ⁽¹⁾	150 50	151 50
63					150 63	151 63
80					150 80	151 80
100					150 96	151 96
125					150 97	151 97

(1) Overtopping described by standards

(2) Overtopping not described by standards



6052 18



6052 04



6052 13

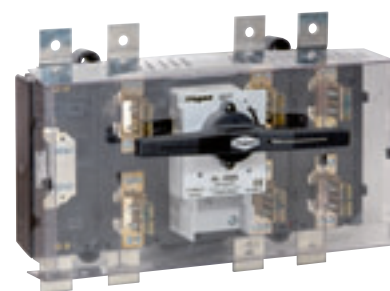

6051 13 + 6051 22

BASE, SPX AND BLADE TYPE CARTRIDGE FUSES

Bases for blade type cartridge fuses

Size	00 - 100 A	00 - 160 A	0 - 160 A	1 - 250 A	2 - 400 A	3 - 630 A	4 - 1250 A
Mounting	┌ rail	screw	screw or ┌ rail			screw	
Single pole base	160 01	162 00		170 00	175 00		
Single pole with micro-switch			165 02	170 02		181 02	185 02
Triple pole	160 05	162 04	165 03	170 03	175 03		
Separation dividers	199 09 ⁽¹⁾		199 15	199 16	199 17	199 18	199 19
Terminal shields	199 20		199 21	199 22	199 23		
Handle	199 02						

(1) for Cat.Nos 160 01 and 162 00

SPX, SPX-V and SPX-D

Cartridge size		000	00	1	2	3
Nominal current (A)		125	160	250	400	630
SPX fuse carriers	Mounting on plate	6052 00	6052 02	6052 04	6052 06	6052 08
	Mounting on collector rail	6052 01	6052 03	6052 05	6052 07	6052 09
SPX-V fuse carriers	Distance between collector rails	60 mm	6052 14			
		100 mm	6052 10			
		185 mm		6052 11	6052 12	6052 13
SPX-D isolating switches	3P		6051 00	6051 01	6051 02	6051 03
	P+N		6051 10	6051 11	6051 12	6051 13

SPX and SPX-V cage terminals

SPX size	Flat terminals			Prism terminals			Extension connector with 3 inputs	Terminals shields
	Cat.Nos	Cross section		Cat.Nos	Cross section			
		conductor (mm ²)	Flexible rail (mm)		conductor (mm ²)	Flexible rail (mm)		
00	6052 18	1.5-70	12 x 10	6052 22	16-70	12 x 18	6052 26	6052 31/49(1)
1	6052 19	70-150	18 x 7-18	6052 23	70-150	18 x 10		6052 32
2	6052 20	120-240	21 x 5-19	6052 24	120-240	21 x 15		6052 33
3	6052 21	150-300	25 x 7-20	6052 25	150-300	25 x 20		6052 34



Connection terminals to feed the bars for SPX and SPX-V

Prism terminals for longitudinal feed

Cat.Nos	Cross section	
	Conductor (mm ²)	bar (mm)
6052 78	70-150	15 x 5
6052 79	120-240	20 x 5
6052 80	150-300	25 x 5

Flat terminals for flat bars

Cat.Nos	Size (mm)	Bar thickness (mm)	In (A)
6052 68	25 x 20	20	250
6052 69	30 x 20	20	400
6052 73	35 x 20	20	600
6052 74	50 x 32	30	600
6052 75	63 x 40	30	800
6052 76	63 x 50	30	1000
6052 77	80 x 60	30	1250

Universal terminals to feed the bars

Cat.Nos	Conductor (mm ²)	Bar thickness (mm)	In (A)
6052 63	1.5-1.6	5	180
6052 64	4-35	5	270
6052 65	16-70	10	400
6052 66	16-120	10	440

Accessories for SPX and SPX-V

	Cat.Nos	SPX					SPX-V			
		000	00	1	2	3	00	1	2	3
Signalling contact : 5 A - 250 V AC ; 4A - 30 V DC	6052 30	•	•	•	•	•	•	•	•	•
Lockable face plate for 4 to 7 mm padlock	6052 35	•								
	6052 36		•							
	6052 37			•	•	•				
Kit for fixing SPX on TH35 for 1 isolator	6052 45	•								
Isolating support for flat copper rail	60 mm phase offset	6052 46	•	•	•	•	•			
	185 mm phase offset	6052 62					•	•	•	•
Collector rail adaptator for installation or SPX 00 on a 185 mm collector rail system	1 x 160 A	6052 50		•						
	2 x 160 A	6052 51		•						

Accessories for SPX-D

	SPX-D			
	160 A	250 A	400 A	630 A
Direct handle	6051 20	6051 21	6051 21	6051 22
External handle	6051 23	6051 24	6051 24	6051 25
Extended shafts for external handle	6051 28	6051 29	6051 29	6051 30
Auxiliary contacts 2NO + 2NC	6051 26	6051 27	6051 27	6051 27
Terminal shields		6051 32	6051 32	6051 33



HRC blade type cartridge fuses type gG/gL						
Rating (A)	Size					
	0	00	1	2	3	4
	Voyant	With indicator	With indicator	With indicator	With indicator	With striker
25	163 18					
32	163 20					
35	163 22					
40	163 25					
50	163 30					
63	163 35	168 35				
80	163 40	168 40				
100	163 45	168 45				
125	163 50	168 50	173 50			
160	163 55	168 55	173 55			
200		168 60 ⁽¹⁾	173 60	178 60		
250			173 65	178 65		
315				178 70		
400				178 75		
500					181 25	
630					181 30	185 80
800						185 85
1000						185 90
1250						185 95 ⁽¹⁾

HRC blade type cartridge fuses type aM						
Rating (A)	Size					
	Taille 00	Taille 0	Taille 1	Taille 2	Taille 3	Taille 4
	With indicator	With striker	With striker	With striker	With striker	With striker
63	160 35	166 35				
80	160 40	166 40				
100	160 45	166 45				
125	160 50 ⁽¹⁾	166 50	171 50			
160		166 55	171 55			
200			171 60	176 60		
250			171 65	176 65		
315				176 70		
400				176 75		
500					180 75	
630					180 80	184 80
800						184 85
1000						184 90

(1) Overtopping not described by standards

POWER GUIDE:

A complete set of technical documentation



01 | Sustainable development



08 | Protection against external disturbances



02 | Power balance and choice of power supply solutions



09 | Operating functions



03 | Electrical energy supply



10 | Enclosures and assembly certification



04 | Sizing conductors and selecting protection devices

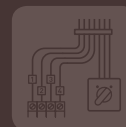

11 | Cabling components and control auxiliaries



05 | Breaking and protection devices

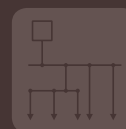

12 | Busbars and distribution



06 | Electrical hazards and protecting people



13 | Transport and distribution inside an installation



07 | Protection against lightning effects



Annexes
Glossary
Lexicon



**World Headquarters and
International Department**
87045 Limoges Cedex - France
☎ : + 33 (0) 5 55 06 87 87
Fax : + 33 (0) 5 55 06 74 55