



POWERDRIVE BATTERY CHARGER OWNER'S MANUAL

Manual Number 101993811

Edition Code 0898N1210L

NOTICE

Club Car is not liable for errors in this manual or for incidental or consequential damages that result from the use of the material in this manual.

The Club Car Limited Warranty appears at the end of this manual. No other warranties, express or implied, are contained herein.

This manual contains proprietary information that is protected by copyright. All rights are reserved. No part of this manual may be photocopied, reproduced, or translated into another language without the written consent of Club Car, LLC.

The information contained in this document is subject to change without notice.

Club Car, LLC reserves the right to change specifications and designs at any time without notice and without the obligation of making changes to units previously sold.



P. O. Box 204658
Augusta, Georgia 30917-4658 USA
Telephone 706-863-3000
Service Parts Fax 706-855-7413
www.clubcar.com

Copyright © 2004, 2005, 2006, 2010
Club Car, LLC
Club Car and PowerDrive are
registered trademarks of Club Car, LLC
This manual effective July 28, 2003.

TABLE OF CONTENTS

Safety Details	6
General Information	6
PowerDrive External Charger Features	8
PowerDrive Onboard Charger Features	9
Battery Warning Light	9
UL and CSA Listing	10
EU Compliance	10
External Charger Installation and Operation	10
External Charger AC Power Connection	11
Charging Batteries	12
External Charger Plug and Receptacle	13
Checking Battery Condition with an External Charger	14
Start Charge Cycle	14
Onboard Charger Operation	15
Onboard Charger AC Power Connection	16
Charging Batteries	16
Checking Battery Condition with an Onboard Charger	17
Start Charge Cycle	17
Battery Charger Specifications	19
Club Car® Limited Four Year Warranty for PowerDrive® Chargers	23

SAFETY DETAILS

WARNING

- This owner's manual should be read completely before attempting to use or service the charger. Failure to follow the instructions in this manual could result in property damage, severe personal injury, or death.

It is important to note that throughout this manual there are statements labeled DANGER, WARNING, or CAUTION. These special statements relate to specific safety issues, and must be read, understood, and heeded before proceeding with procedures.

If any of the information printed on the cover of the charger becomes damaged, has been removed, or cannot be easily read, replace the cover immediately to avoid possible property damage, personal injury, or death. Contact your Club Car distributor/dealer for replacement information.

DANGER

- A DANGER indicates an immediate hazard that will result in severe personal injury or death.

WARNING

- A WARNING indicates an immediate hazard that could result in severe personal injury or death.

CAUTION

- A CAUTION with the safety alert symbol indicates a hazard or unsafe practice that could result in minor personal injury or product or property damage.

CAUTION

- A CAUTION without the safety alert symbol indicates a situation that potentially could result in property damage.

The safety precautions listed must be followed whenever the charger is being operated, repaired, or serviced. Specific warnings appear throughout this manual and on the charger.

GENERAL INFORMATION

PowerDrive battery chargers are available in several different configurations for use domestically (United States) and internationally (**Figures 1 through 7**). Some PowerDrive chargers are equipped with a multi-position switch (located on the rear panel) for AC input voltage selection (**Figure 8**).

The PowerDrive battery charger is automatic and has no external controls. When the charger is connected, there is a 2 to 15 second delay before charging begins.

NOTE: PowerDrive and PowerDrive Plus Vehicles: Shortly after charging begins, the charger will shut off in order to run a self-diagnostic program (ammeter will drop to zero). Charging will resume in a few moments (ammeter returns to previous rate of charge). This will be repeated at one hour and at two hours into the charge cycle.

IQ System Vehicles: At one hour and at two hours into the charge cycle, the charger will shut off in order to run a self-diagnostic program (ammeter will drop to zero). Charging will resume in a few moments (ammeter returns to previous rate of charge).

The onboard computer, having recorded the amount of energy consumed as the vehicle was used, directs the charger to replace exactly the amount of energy needed to fully replenish the batteries. The charger then shuts off automatically, preventing the possibility of either undercharging or overcharging. The computer accomplishes this by detecting when the exact amount of energy necessary has been returned to the batteries.

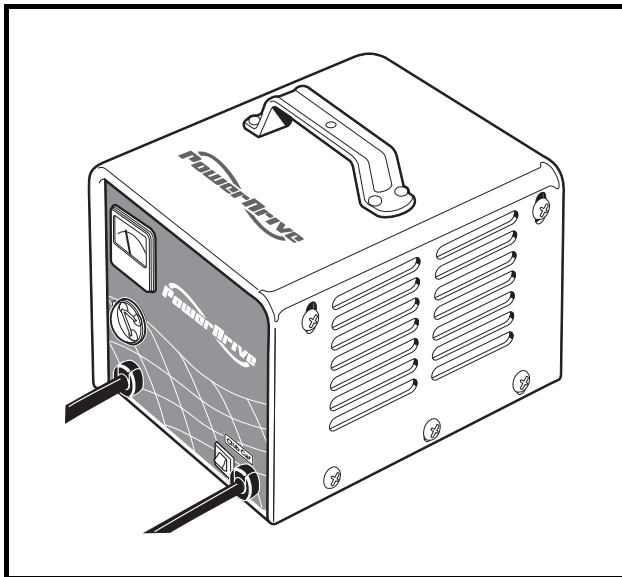

**Figure 1 Domestic PowerDrive External Charger
Models 17930-11, 17930-18, and 17930-19**

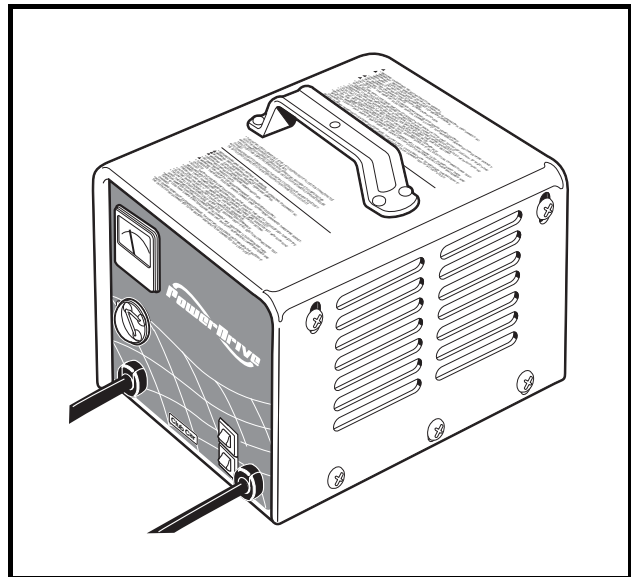

**Figure 2 Export PowerDrive External Charger
Models 18780-11, and 18780-18**

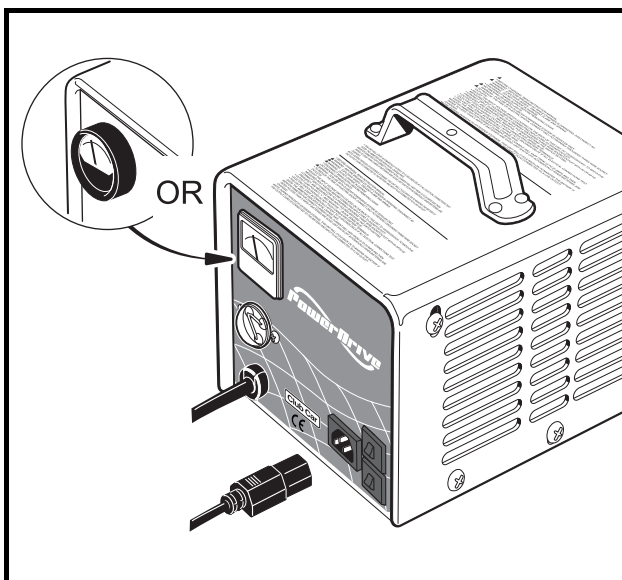

**Figure 3 European PowerDrive External Charger
Models 20310-11, and 20310-18**

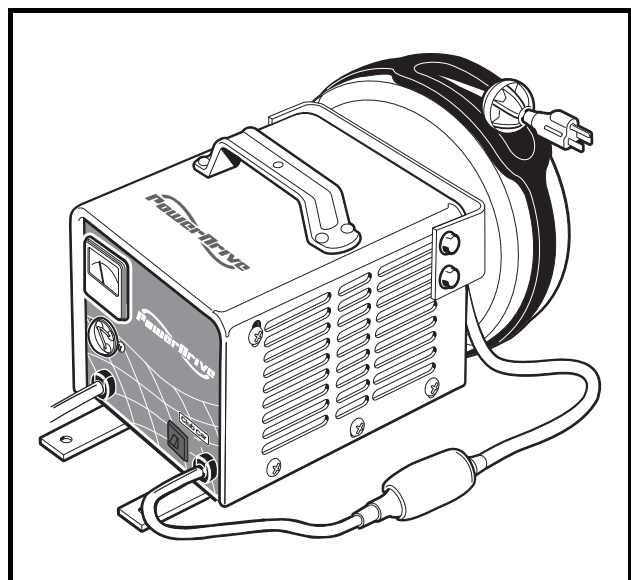

**Figure 4 Domestic PowerDrive Onboard Charger
Models 17935-10, 17935-20, 17935-30, and 17935-40**

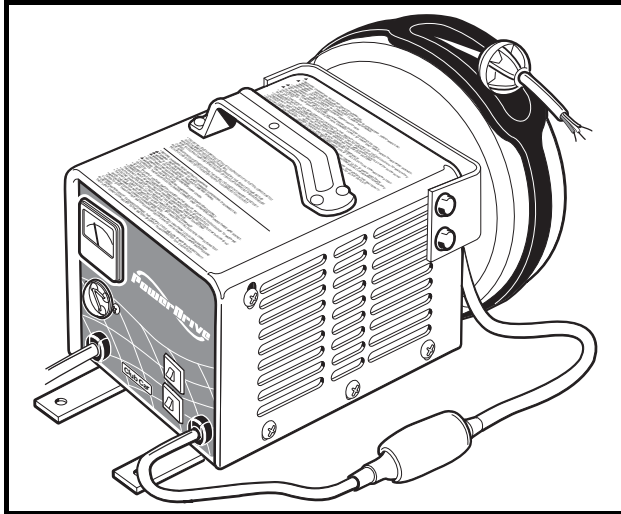

Figure 5 Export PowerDrive Onboard Charger
Models 17790-10, 17790-20, 17790-30, and 17790-40

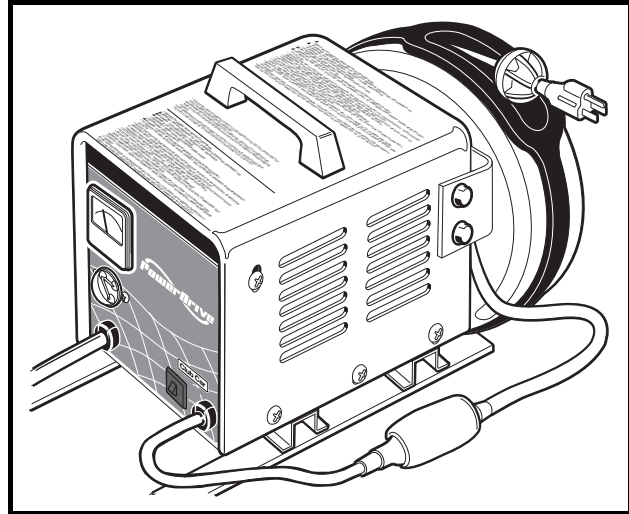

Figure 6 Domestic PowerDrive Onboard Charger
Model 19770-98

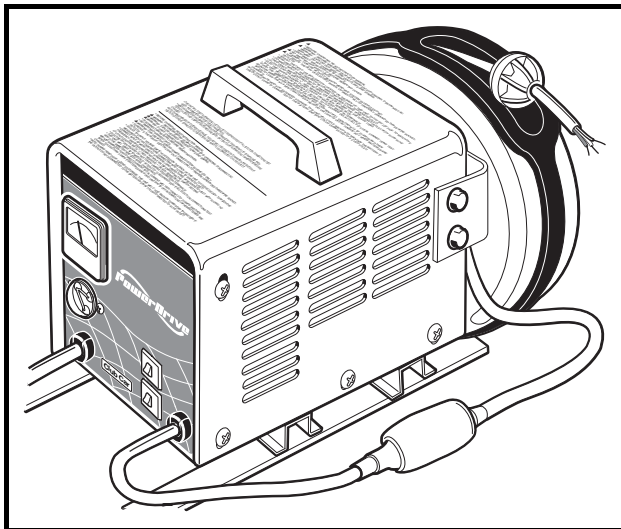

Figure 7 Export PowerDrive Onboard Charger
Model 19710

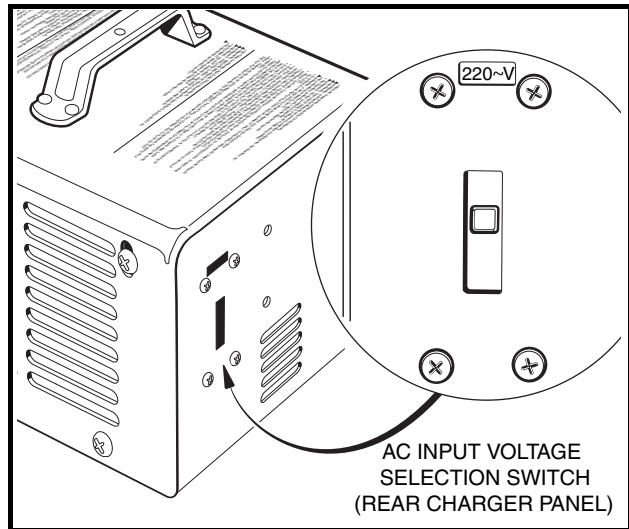

Figure 8 AC Input Voltage Selection Switch

POWERDRIVE EXTERNAL CHARGER FEATURES

- **Charge Interlock**

PowerDrive battery charger DC plugs have three pins rather than two blades common on most standard charger plugs. Two of these pins are the positive and negative leads as on standard chargers; the third pin is a sensing lead that is the communication link between the charger and the onboard computer. When the charger plug is plugged into the vehicle receptacle, the onboard computer locks out the vehicle drive system. This prevents the possibility of driving the vehicle while the charger is plugged in and potentially damaging the vehicle and charger.

- **Long-Term Storage Charge**

IQ System, PowerDrive, and PowerDrive Plus vehicles with PowerDrive chargers are designed to be left connected with AC power to the charger, during off-season or long-term storage. The onboard computer will automatically activate the charger every 15 days. To return the vehicle to service, unplug the

charger DC cord, wait 15 seconds for the computer to reset, and plug the charger back in. **See following WARNING.** This will ensure the batteries are at their optimum charge prior to returning the vehicle to service.

⚠ WARNING

- **The charger plug must be pulled slowly from the receptacle. Jerking or pulling the DC cord out quickly could cause arcing and burning that could damage the plug and receptacle and could cause batteries to explode.**

CAUTION

- **Be sure to check the batteries and charger monthly to maintain correct battery water level and ensure the charger is operating correctly during storage.**

POWERDRIVE ONBOARD CHARGER FEATURES

- **Charge Interlock**

When the AC power cord is inserted into a wall receptacle, the onboard computer locks out the vehicle drive system. This prevents the possibility of driving the vehicle while the charger is plugged in and potentially damaging the vehicle and charger.

- **Long-Term Storage Charge**

PowerDrive chargers are designed to be left connected with AC power to the charger, during off-season or long-term storage. The onboard computer will automatically activate the charger every 15 days. To return the vehicle to service, disconnect the AC cord from the wall outlet, wait 15 seconds and then plug the AC cord back in. The charger will activate. Allow the vehicle to complete one full charge cycle before putting it into service.

BATTERY WARNING LIGHT

IQ System, PowerDrive, and PowerDrive Plus vehicles feature a dash mounted battery warning light (above the steering column) that, when the vehicle is in operation, indicates low battery voltage or, when the vehicle is being charged, indicates a charging problem. The battery warning light is controlled by the onboard computer. **See following NOTE.**

NOTE: Beginning with the 1998 model year, the onboard computer LED became part of the battery warning light rather than being mounted in the computer itself, and the warning light lens color changed from red to amber. This simplifies using a Communication Display Module (CCI P/N 101831801) to obtain data from the onboard computer.

When the batteries receive an incomplete charge because 1) the DC power cord is disconnected, 2) AC power to charger is interrupted, 3) automatic charger shut-off occurs after 16 hours of operation, or 4) charger malfunctions, the warning light will indicate as follows:

- The battery warning light will not illuminate if the charge is 90% or more complete. The onboard computer will retain in memory the amount of charge needed to replenish the batteries and will complete the charge during the next charge cycle.
- When the charger DC cord is unplugged during a charge cycle, the battery warning light will illuminate and remain illuminated for 10 seconds (25 seconds for Precedent vehicles) if the charge is less than 90% complete but the vehicle has enough power for 60 minutes of operation. This will alert the fleet operator that the vehicle may be used, but that it must be charged to completion as soon as possible.
- The battery warning light will repeatedly illuminate for 10 seconds, at 4 second intervals (25 seconds, at 10 second intervals for Precedent vehicles), if the charger times out at 16 hours and the batteries are not sufficiently charged. This indicates an abnormal charge cycle. The charger and batteries should be

checked by your Club Car distributor/dealer.

- **External chargers only:** The battery warning light will repeatedly illuminate for 10 seconds, at 4 second intervals (25 seconds, at 10 second intervals for Precedent vehicles), during a charge cycle (with the DC plug still connected) if AC power to the charger is interrupted. The light will go out when AC power is restored.

UL AND CSA LISTING

When operated on a 120-volt / 60 Hz electrical system, the following PowerDrive battery chargers have been listed by Underwriters Laboratories and by the Canadian Underwriters (thereby meeting the criteria of the Canadian Standards Association).

PowerDrive external battery charger models: 17930-11, 17930-18, and 17930-19.

PowerDrive onboard battery charger models: 17935-10, 17935-20, 17935-30, 17935-40, and 19770-98.

EU COMPLIANCE

The following PowerDrive battery chargers are compliant with the EU Low-Voltage Directive.

PowerDrive external battery charger models: 20310-11, and 20310-18.

EXTERNAL CHARGER INSTALLATION AND OPERATION

DANGER

- The charging area must be ventilated. Hydrogen level in the air must never exceed 2%. The total volume of air in the charging area must be changed five times per hour. Exhaust fans should be located at the highest point of the roof. Contact a local HVAC engineer.
- Do not charge the vehicle batteries with the vehicle covered or enclosed. Any enclosure or cover should be removed or unzipped and pulled back when batteries are being charged. An accumulation of hydrogen gas could result in an explosion.

WARNING

- Only trained technicians should repair or service the charger. Contact your nearest Club Car distributor/dealer.
- Each charger should have its own dedicated 15 or 20 ampere separately protected (circuit breaker or fuse) single phase branch circuit, in accordance with all applicable electrical codes for the location.
- Connect the charger AC supply cord to a properly grounded, three-wire outlet of the proper voltage and frequency as shown on the charger.
- Do not use an adapter to plug the charger with a three-prong plug into a two-prong outlet. Improper connection of the equipment-grounding conductor can result in a fire or an electrical shock.
- An extension cord or electrical outlet must accept a three-prong plug. Extension cord should be a three-wire no. 12 AWG (American Wire Gauge) or no. 14 (British Standard Wire), and be as short as possible (no more than 12 feet (3.7 m)). The use of improper extension cord could result in fire or an electrical shock.
- Do not use near fuels, grain dust, solvents, thinners, or other flammables. Chargers can ignite flammable materials and vapors.
- Do not expose to rain or any liquid. Keep the charger dry.
- Prior to servicing the charger, disconnect the AC power supply cord from the wall outlet and

the DC plug from the vehicle charger receptacle.

- When the charger is on, the charger DC cord may be disconnected from the vehicle receptacle slowly. Jerking or pulling the DC cord out quickly could cause arcing and burning that could damage the plug and receptacle and could cause batteries to explode.
- Never push objects of any kind into the charger through cabinet slots. They may touch dangerous voltage points or cause an electrical short circuit that could result in fire or electrical shock.
- Do not connect the charger to battery packs that are not compatible with the DC output voltage specified on the charger. Overheating and transformer burnout will result.
- Do not connect a stationary charger to the receptacle if the charger cord, plug, or the vehicle receptacle is broken, damaged, or does not make a good electrical connection. Fire or personal injury can result. Have a qualified technician replace the parts.
- Do not use a battery charger if the cord, plug, or receptacle is damaged in any way. Replace worn or damaged parts immediately. Failure to heed this warning could result in a fire, property damage, severe personal injury, or death.
- Do not operate the charger if it has received a sharp blow, was dropped, or otherwise damaged in any way.
- Have worn, cut, or damaged power cords or wires replaced immediately.
- Do not block or cover the charger ventilation slots. The slots provide ventilation and prevent the charger from overheating.
- Do not allow clothing, blankets, or other material to cover the charger.
- Do not allow the charger to operate for more than 30 minutes at 19 or more amperes.
- Install surge arrestors on incoming AC power lines. Surge arrestors will help protect electrical components in the charger and on the vehicle from all but direct or close lightning strikes.

NOTE: Charger operation instructions in the language of the user should be printed on or permanently affixed to the top of the charger. If these instructions are not found on the charger, contact your Club Car representative.

EXTERNAL CHARGER AC POWER CONNECTION

The AC line to which the charger is to be connected must be of the proper AC input voltage for the charger and must be capable of supplying sufficient current. **See Battery Charger Specifications on page 19.** If the battery charger is equipped with a multi-position switch for variable AC input voltage, the switch must be set for the correct voltage before the AC cord is connected (**Figure 8**). **See following CAUTION.**

CAUTION

- Failure to set the AC input voltage selector switch to the correct voltage could result in damage to the battery charger or batteries.

NOTE: Make sure that the AC cord provided with your charger has the proper AC plug for your location. If it does not, contact your Club Car representative to obtain the proper cord or plug.

With charger DC output cord disconnected, connect the power supply cord to an AC supply. **See Battery Charger Specifications on page 19.**

To reduce the risk of electric shock, the battery charger must be grounded. The charger is equipped with an AC electric cord with an equipment-grounding conductor and a grounding type plug. The AC plug must be connected to an appropriate receptacle that is properly installed and grounded in accordance with the National Electric Code and all local codes and ordinances.

The use of an extension cord with the charger should be avoided. If an extension cord must be used, use a three-conductor no. 12 AWG (American Wire Gauge) or no. 14 SWG (British Standard Wire Gauge), heavy-duty cord with ground, properly wired and in good electrical condition. Keep it as short as possible (no more than 12 feet (3.7 m)). Place all cords so they will not be stepped on, tripped over, or otherwise subject to damage or stress.

Ensure that the charger ventilation slots are unobstructed and that there is adequate ventilation.

CHARGING BATTERIES

⚠ WARNING

- **Do not bypass the sense lead fuse (not applicable to Precedent vehicles; not applicable to TransPorter and Carryall 6 vehicles that do not have a charger receptacle).**
 - **Be sure the fuse link is clean and tight (not applicable to Precedent vehicles; not applicable to TransPorter and Carryall 6 vehicles that do not have a charger receptacle).**
 - **Be sure all wire connections at the receptacle are clean and tight.**
 - **Do not rock or bend the plug. To connect the charger plug to the vehicle receptacle, grasp the plug handle and push the plug straight into the receptacle (Figure 9).**
 - **Do not pull on the DC cord (Figure 10). Do not twist, rock or bend the plug. To disconnect the charger plug from the vehicle receptacle, grasp the plug by the handle and pull the plug straight out of the receptacle.**
 - **Do not connect a charger to the receptacle if the charger cord, plug, or the vehicle receptacle is broken, damaged in any manner, or does not make a good electrical connection. Fire or personal injury can result. Have it replaced by a qualified service person immediately. Failure to follow these instructions could result in damage to the charger cord, the plug, and (or) the vehicle receptacle.**
 - **Do not use a charger if any of the following conditions exist:**
 - **The plug is too loose or does not make a good connection.**
 - **The plug and receptacle feel hotter than normal during charge.**
 - **The plug pin or receptacle contacts are bent or corroded.**
 - **The plug, receptacle, or cords are cut, worn, have any exposed wires or are damaged in any way.**
 - **Using the charger with any of the above symptoms could result in a fire, property damage, personal injury, or death.**
1. With the charger DC cord disconnected from the vehicle charger receptacle, connect the AC power supply cord to an AC outlet designed to provide the proper AC voltage for the charger.
 2. Connect the charger DC plug to the vehicle charger receptacle located on the seat support panel (Figure 9). The charger will activate automatically within 2 to 15 seconds after the DC plug is connected. **See following WARNING.**

⚠ WARNING

- **Do not rock or bend the plug. To connect the charger plug to the vehicle receptacle, grasp the plug handle and push the plug straight into the receptacle (Figure 9).**
3. **PowerDrive and PowerDrive Plus vehicles:** 10 to 20 seconds after the charger activates, it will shut off again to run a self-diagnostic program (the ammeter will drop to 0). Charging will resume in a few moments (ammeter will return to previous rate of charge).

4. Monitor the ammeter for the correct charge rate. The initial charge rate will vary from 15 to 19 amps, depending upon the condition and depth of discharge of the batteries. Slight variations in the initial charge rate may also result from AC line input voltages which are higher or lower than the nominal input voltage. Higher AC line voltages increase the initial charge rate while lower AC line voltages reduce the initial charge rate.
5. **PowerDrive and PowerDrive Plus vehicles:** Monitor the ammeter for about 30 seconds. Under normal operating conditions (when the charger is on and the batteries are discharged), the ammeter will drop to zero for 2 to 3 seconds at the beginning of each charge cycle in order to perform a self-diagnostic test. This test will be repeated at one hour and two hours into the charge cycle. **See following NOTE.**
6. **IQ System vehicles:** At one hour and at two hours into the charge cycle, the charger will shut off in order to run a self-diagnostic program (ammeter will drop to zero). Charging will resume in a few moments (ammeter returns to previous rate of charge).

NOTE: PowerDrive and PowerDrive Plus vehicles: If the batteries are in a fully charged state and the vehicle has not been driven, the onboard computer will not perform the self-diagnostic test.

All vehicles: Batteries should be put on charge at the end of each day even if the vehicle has been used for only a short amount of time (even if for only 10 minutes).

When air temperatures fall below 65°F (18.3°C), batteries charged in unheated areas should be placed on charge as soon as possible after use. Cold batteries require more time to fully charge.

New batteries will not deliver their full range until the vehicle has been driven and recharged from 20 to 50 times.

Vehicles should be restricted to 40 to 50 energy units of discharge (or 36 holes of golf) between charges until the batteries have been properly seasoned (20 to 50 charge cycles). For maximum battery life, Club Car recommends that electric vehicles always be recharged after 40 to 50 energy units of discharge or each night in order to avoid deep discharging the batteries. Charging between rounds will also extend battery life; use the CDM (Communication Display Module) (CCI P/N 101831801).

See Communication Display Module in the appropriate maintenance and service supplement.

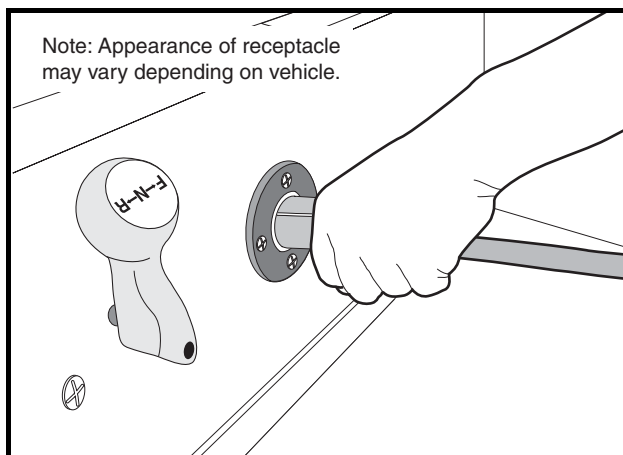

Figure 9 Charger Receptacle

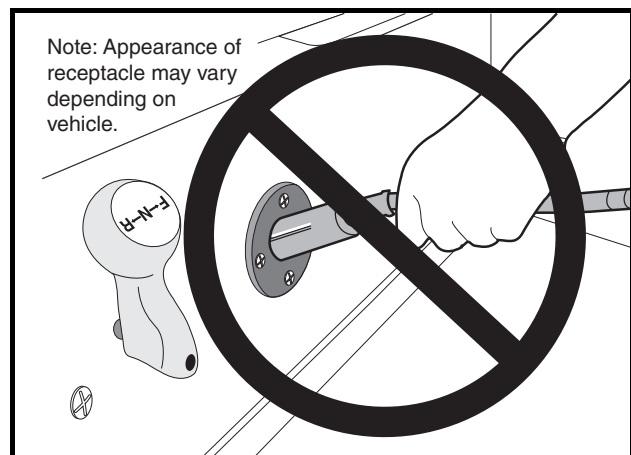

Figure 10 Incorrect Charger Cord Removal

EXTERNAL CHARGER PLUG AND RECEPTACLE

When inserting the DC plug into the vehicle receptacle, align the raised guide on the plug with the guide slot in the receptacle and slowly push the plug straight in (**Figure 9**). To disconnect the plug from the vehicle, firmly grasp the plug, not the cord (**Figure 10**), and slowly pull plug straight out. **See following WARNING and CAUTION.**

⚠ WARNING

- Do not rock or bend the plug. To connect the charger plug to the vehicle receptacle, grasp the plug handle and push the plug straight into the receptacle (Figure 9).
- The battery charger DC plug must be pulled slowly from the receptacle. Jerking or pulling the DC cord out quickly could cause arcing that could damage the plug and receptacle and could cause batteries to explode.
- Do not use a battery charger if the cord, plug, or receptacle is damaged in any way. Replace worn or damaged parts immediately. Failure to heed this warning could result in a fire, property damage, severe personal injury, or death.

⚠ CAUTION

- Do not connect an external charger to the receptacle of a vehicle equipped with an onboard charger while the onboard charger is activated. Charging overload will damage the onboard computer and may cause battery damage.

The charger cord, plug, and receptacle are wear items and should be inspected daily. Visually inspect them for cracks, loose connections, and frayed wiring; they must be replaced when worn or damaged. If charger plug or receptacle show signs of corrosion or the plug is difficult to insert or remove, the receptacle contacts and plug terminals should be cleaned with a good electrical contact cleaner. The plug should then be inserted and removed several times to ensure ease of insertion, ease of removal, and good electrical contact. **See following NOTE.**

NOTE: If the warning tag has been damaged or removed from the DC cord, have it replaced immediately.

CHECKING BATTERY CONDITION WITH AN EXTERNAL CHARGER

Read DANGER, WARNING, and CAUTIONS beginning on page 10.

It is common practice for technicians to check the condition of a set of batteries after they have been charged to ensure they have received a complete charge before the vehicle is used. With IQ System, PowerDrive, and PowerDrive Plus vehicles, this is not necessary; the onboard computer controls and monitors the charge cycle. If any problem occurs during a charge cycle, the battery warning light, located above the steering column in the center dash panel, will illuminate intermittently.

If the battery warning light is illuminated after a charge cycle, refer to the troubleshooting chart in the maintenance and service manual appropriate for your battery charger. If you do not have this publication, contact your Club Car representative. If the specified test procedures identify no problems, plug the DC cord into the vehicle and let it charge until the charger shuts off automatically. If a problem is found, correct it and then charge the vehicle. Normal voltage near the end of a charge cycle should be approximately 59 to 63 volts DC.

START CHARGE CYCLE

1. Disconnect the DC plug from the vehicle charger receptacle.
2. Wait 20 seconds, then reconnect the DC cord to the vehicle receptacle. **See following NOTE.**

NOTE: The charger will not operate unless a delay of approximately 20 seconds is observed.

3. Monitor the ammeter for the charge rate. **PowerDrive and PowerDrive Plus vehicles:** If the vehicle has not been driven since the last charge cycle and the batteries are fully charged, the onboard computer will not perform a self-diagnostic test. The charge cycle will begin and the ammeter will not drop to zero. If the vehicle has been driven, even if only a few feet, the onboard computer will perform the self-diagnostic test; the ammeter will drop to zero for 2 to 3 seconds before the charge cycle continues. **All vehicles:** If the batteries are close to being fully charged, the charge cycle will begin and the charge current will begin to taper within a few minutes.

ONBOARD CHARGER OPERATION

DANGER

- The charging area must be ventilated. Hydrogen level in the air must never exceed 2%. The total volume of air in the charging area must be changed five times per hour. Exhaust fans should be located at the highest point of the roof. Contact a local HVAC engineer.
- Do not charge the vehicle batteries with the vehicle covered or enclosed. Any enclosure or cover should be removed or unzipped and pulled back when batteries are being charged. An accumulation of hydrogen gas could result in an explosion.

WARNING

- Only trained technicians should repair or service the charger. Contact your nearest Club Car distributor/dealer.
- Each charger should have its own dedicated 15 or 20 ampere separately protected (circuit breaker or fuse) single phase branch circuit, in accordance with all applicable electrical codes for the location.
- Connect the charger AC supply cord to a properly grounded, three-wire outlet of the proper voltage and frequency as shown on the charger.
- Do not use an adapter to plug the charger with a three-prong plug into a two-prong outlet. Improper connection of the equipment-grounding conductor can result in a fire or an electrical shock.
- Do not use an extension cord.
- Do not use near fuels, grain dust, solvents, thinners, or other flammables. Chargers can ignite flammable materials and vapors.
- Do not expose to rain or any liquid. Keep the charger dry.
- Prior to servicing the charger, disconnect the AC power supply cord from the wall outlet remove the battery charger from the vehicle. See Onboard Charger Removal in the appropriate maintenance and service manual.
- Never push objects of any kind into the charger through cabinet slots. They may touch dangerous voltage points or cause an electrical short circuit that could result in fire or electrical shock.
- Do not use a battery charger if the cord or plug is damaged in any way. Replace worn or damaged parts immediately. Failure to heed this warning could result in a fire, property damage, severe personal injury, or death.
- Do not operate the charger if it has received a sharp blow, was dropped, or otherwise damaged in any way.
- Have worn, cut, or damaged power cords or wires replaced immediately.

- **Do not block or cover the charger ventilation slots. The slots provide ventilation and prevent the charger from overheating.**
- **Do not allow clothing, blankets, or other material to cover the charger.**
- **Do not allow the charger to operate for more than 30 minutes at 19 or more amperes.**
- **Install surge arrestors on incoming AC power lines. Surge arrestors will help protect electrical components in the charger and on the vehicle from all but direct or close lightning strikes.**

ONBOARD CHARGER AC POWER CONNECTION

The AC line to which the charger is to be connected must be of the proper AC input voltage for the charger and must be capable of supplying sufficient current. **See Battery Charger Specifications on page 19.** If the battery charger is equipped with a multi-position switch for variable AC input voltage, the switch must be set for the correct voltage before the AC cord is connected (**Figure 8**). **See following CAUTION.**

⚠ CAUTION

- **Failure to set the AC input voltage selector switch to the correct voltage could result in damage to the battery charger or batteries.**

NOTE: Make sure that the AC cord provided with your charger has the proper AC plug for your location. If it does not, contact your Club Car representative to obtain the proper cord or plug.

Connect the power supply cord to an AC supply. **See Battery Charger Specifications on page 19.**

To reduce the risk of electric shock, the battery charger must be grounded. The charger is equipped with an AC electric cord with an equipment-grounding conductor and a grounding type plug. The AC plug must be connected to an appropriate receptacle that is properly installed and grounded in accordance with the National Electric Code and all local codes and ordinances.

Place the charger AC cord so it will not be stepped on, tripped over, or otherwise subject to damage or stress. The use of an extension cord with the onboard charger must be avoided.

Do not place items in the compartment where the battery charger is installed. Ensure that the charger ventilation slots are unobstructed.

CHARGING BATTERIES

1. Connect the AC power supply cord to an AC outlet designed to provide the proper AC voltage for the charger. The charger will activate automatically within 2 to 15 seconds.
2. Monitor the ammeter for the correct charge rate. The initial charge rate will vary from 15 to 19 amps, depending upon the condition and depth of discharge of the batteries. Slight variations in the initial charge rate may also result from AC line input voltages which are higher or lower than the nominal input voltage. Higher AC line voltages increase the initial charge rate while lower AC line voltages reduce the initial charge rate.
3. **PowerDrive and PowerDrive Plus vehicles:** Monitor the ammeter for about 30 seconds. Under normal operating conditions (when the charger is on and the batteries are discharged), the ammeter will drop to zero for 2 to 3 seconds at the beginning of each charge cycle in order to perform a self-diagnostic test. This test will be repeated at one hour and two hours into the charge cycle. **See following CAUTION and NOTE.**
4. **IQ System vehicles:** At one hour and at two hours into the charge cycle, the charger will shut off in order to run a self-diagnostic program (ammeter will drop to zero). Charging will resume in a few moments (ammeter returns to previous rate of charge). **See following CAUTION and NOTE.**

⚠ CAUTION

- **Do not connect an external charger to the receptacle of a vehicle equipped with an onboard charger while the onboard charger is activated. Charging overload will damage the onboard computer and may cause battery damage.**

NOTE: PowerDrive and PowerDrive Plus vehicles: If the batteries are in a fully charged state and the vehicle has not been driven, the onboard computer will not perform the self-diagnostic test.

All vehicles: Batteries should be put on charge at the end of each day even if the vehicle has been used for only a short amount of time (even if for only 10 minutes).

When air temperatures fall below 65 °F (18.3 °C), batteries charged in unheated areas should be placed on charge as soon as possible after use. Cold batteries require more time to fully charge.

New batteries will not deliver their full range until the vehicle has been driven and recharged from 20 to 50 times.

Vehicles should be restricted to 40 to 50 energy units of discharge (or 36 holes of golf) between charges until the batteries have been properly seasoned (20 to 50 charge cycles). For maximum battery life, Club Car recommends that electric vehicles always be recharged after 40 to 50 energy units of discharge or each night in order to avoid deep discharging the batteries. Charging between rounds will also extend battery life; use the CDM (Communication Display Module) (CCI P/N 101831801). **See Communication Display Module in the appropriate maintenance and service supplement.**

CHECKING BATTERY CONDITION WITH AN ONBOARD CHARGER

Read DANGER, WARNING, and CAUTIONS beginning on page 10.

It is common practice for technicians to check the condition of a set of batteries after they have been charged to ensure they have received a complete charge before the vehicle is used. With IQ System, PowerDrive, and PowerDrive Plus vehicles, this is not necessary; the onboard computer controls and monitors the charge cycle. If any problem occurs during a charge cycle, the battery warning light, located above the steering column in the center dash panel, will illuminate intermittently.

If the battery warning light is illuminated after a charge cycle, refer to the troubleshooting chart in the maintenance and service manual appropriate for your battery charger. If you do not have this publication, contact your Club Car representative. If the specified test procedures identify no problems, plug the AC cord into the wall outlet and let it charge until the charger shuts off automatically. If a problem is found, correct it and then charge the vehicle. Normal voltage near the end of a charge cycle should be approximately 59 to 63 volts DC.

START CHARGE CYCLE

1. Disconnect the AC plug from the wall outlet.
2. Wait 20 seconds, then reconnect the AC cord to the wall outlet. **See following NOTE.**

NOTE: The charger will not operate unless a delay of approximately 20 seconds is observed.

3. **PowerDrive and PowerDrive Plus vehicles:** Monitor the ammeter for the charge rate. If the vehicle has not been driven since the last charge cycle and the batteries are fully charged, the onboard computer will not perform a self-diagnostic test. The charge cycle will begin and the ammeter will not drop to zero. If the vehicle has been driven, even if only a few feet, the onboard computer will perform the self-diagnostic test; the ammeter will drop to zero for 2 to 3 seconds before the charge cycle continues. If the batteries are close to being fully charged, the charge cycle will begin and the charge current will begin to taper within a few minutes.
4. **IQ System vehicles: IQ System vehicles:** At one hour and at two hours into the charge cycle, the charger will shut off in order to run a self-diagnostic program (ammeter will drop to zero). Charging will resume in a few moments (ammeter returns to previous rate of charge).

NOTE: PowerDrive and PowerDrive Plus vehicles: If the batteries are in a fully charged state and the vehicle has not been driven, the onboard computer will not perform the self-diagnostic test.

BATTERY CHARGER SPECIFICATIONS

DOMESTIC POWERDRIVE CHARGER SPECIFICATIONS	Domestic PowerDrive External Battery Charger		
Model number (CCI P/N)	17930-11 (101802201)	17930-18 (101802202)	17930-19 (101802203)
AC INPUT			
AC voltage: 105-128 VAC (acceptable range)	•	•	•
Frequency: 60 Hz.	•	•	•
POWER CONSUMPTION			
Max. AC current (amps)	10.71	10.71	10.71
DC OUTPUT			
DC voltage (VDC) (start of charge cycle)	48	48	48
DC current (amps) (start of charge cycle)	17	17	17
DC voltage (VDC) (end of charge cycle)	60	60	60
DC current (amps) (end of charge cycle)	3.5	3.5	3.5
DIMENSIONS/WEIGHT			
Case – overall length	10.25 in. (26 cm)	10.25 in. (26 cm)	10.25 in. (26 cm)
Case – overall width	8.687 in. (22.1 cm)	8.687 in. (22.1 cm)	8.687 in. (22.1 cm)
Case – overall height	9.0 in. (22.9 cm)	9.0 in. (22.9 cm)	9.0 in. (22.9 cm)
AC cord length	74 in. (188 cm)	108 in. (274.3 cm)	108 in. (274.3 cm)
DC cord length	103 in. (261.6 cm)	144 in. (365.8 cm)	240 in. (609.6 cm)
Weight	31.0 lb (14.1 kg)	31.6 lb (14.3 kg)	33.0 lb (15.0 kg)
MOUNTING CONFIGURATION			
Mounting: Set on shelf, wall mount with keyhole, or hang securely from ceiling.	•	•	•
Mounting: Onboard (secured to the vehicle)			

Battery Charger Specifications

DOMESTIC POWERDRIVE CHARGER SPECIFICATIONS	Domestic PowerDrive Onboard Battery Charger				
	Model number (CCI P/N)	17935-10 (101814301)	17935-20 (101814303)	17935-30 (101814304)	17935-40 (102546901)
AC INPUT					
AC voltage: 105-128 VAC (acceptable range)	•	•	•	•	•
Frequency: 60 Hz.	•	•	•	•	•
POWER CONSUMPTION					
Max. AC current (amps)	10.71	10.71	10.71	10.71	10.71
DC OUTPUT					
DC voltage (VDC) (start of charge cycle)	48	48	48	48	48
DC current (amps) (start of charge cycle)	17	17	17	17	17
DC voltage (VDC) (end of charge cycle)	60	60	60	60	60
DC current (amps) (end of charge cycle)	3.5	3.5	3.5	3.5	3.5
DIMENSIONS/WEIGHT					
Case – overall length	10.25 in. (26 cm)	10.25 in. (26 cm)	10.25 in. (26 cm)	10.25 in. (26 cm)	10.25 in. (26 cm)
Case – overall width	8.687 in. (22.1 cm)	8.687 in. (22.1 cm)	8.687 in. (22.1 cm)	8.687 in. (22.1 cm)	7.25 in. (18.4 cm)
Case – overall height	9.437 in. (24 cm)	9.437 in. (24 cm)	9.437 in. (24 cm)	9.437 in. (24 cm)	9.5 in. (24.1 cm)
AC cord length	17 ft. (5.2 m) (retractable)	17 ft. (5.2 m) (retractable)	17 ft. (5.2 m) (retractable)	17 ft. (5.2 m) (retractable)	17 ft. (5.2 m) (retractable)
DC cord length	80.5 in. (204.5 cm)	129.5 in. (328.9 cm)	162.5 in. (412.8 cm)	9.5 in. (24 cm)	21.5 in. (54.6 cm)
Weight	37.0 lb (16.8 kg)	37.7 lb (17.1 kg)	38.2 lb (17.3 kg)	38.2 lb (17.3 kg)	37.7 lb (17.1 kg)
MOUNTING CONFIGURATION					
Mounting: Set on shelf, wall mount with keyhole, or hang securely from ceiling.					
Mounting: Onboard (secured to the vehicle)	•	•	•	•	•

Battery Charger Specifications

EXPORT POWERDRIVE EXTERNAL CHARGER SPECIFICATIONS	European PowerDrive External Battery Charger		Export PowerDrive External Battery Charger	
	Model number (CCI P/N)	20310-11 (101956201)	20310-18 (101956202)	18780-11 (101831503)
AC INPUT				
AC voltage: 100, 200, 220, or 240 VAC (selectable)	•	•	•	•
AC voltage (acceptable range): at 100 VAC setting	95-105	95-105	95-105	95-105
AC voltage (acceptable range): at 200 VAC setting	190-210	190-210	190-210	190-210
AC voltage (acceptable range): at 220 VAC setting	209-231	209-231	209-231	209-231
AC voltage (acceptable range): at 240 VAC setting	228-252	228-252	228-252	228-252
Frequency: 50 Hz. / 60 Hz.	•	•	•	•
POWER CONSUMPTION				
Max. AC current (amps) at 100 VAC / 50 Hz.	13.6	13.6	13.6	13.6
Max. AC current (amps) at 100 VAC / 60 Hz.	12.4	12.4	12.4	12.4
Max. AC current (amps) at 200 VAC / 50 Hz.	6.9	6.9	6.9	6.9
Max. AC current (amps) at 200 VAC / 60 Hz.	6.3	6.3	6.3	6.3
Max. AC current (amps) at 220 VAC / 50 Hz.	6.9	6.9	6.9	6.9
Max. AC current (amps) at 220 VAC / 60 Hz.	6.3	6.3	6.3	6.3
Max. AC current (amps) at 240 VAC / 50 Hz.	5.9	5.9	5.9	5.9
Max. AC current (amps) at 240 VAC / 60 Hz.	5.1	5.1	5.1	5.1
DC OUTPUT				
DC voltage (VDC) (start of charge cycle)	48	48	48	48
DC current (amps) (start of charge cycle)	17	17	17	17
DC voltage (VDC) (end of charge cycle)	60	60	60	60
DC current (amps) (end of charge cycle)	3.5	3.5	3.5	3.5
DIMENSIONS/WEIGHT				
Case – overall length	10.25 in. (26 cm)	10.25 in. (26 cm)	10.25 in. (26 cm)	10.25 in. (26 cm)
Case – overall width	8.687 in. (22.1 cm)	8.687 in. (22.1 cm)	8.687 in. (22.1 cm)	8.687 in. (22.1 cm)
Case – overall height	9.0 in. (22.9 cm)	9.0 in. (22.9 cm)	9.0 in. (22.9 cm)	9.0 in. (22.9 cm)
AC cord length	N/A	N/A	72 in. (182.9 cm)	108 in. (274.3 cm)
DC cord length	103 in. (261.6 cm)	144 in. (365.8 cm)	103 in. (261.6 cm)	144 in. (365.8 cm)
Weight	34.8 lb (15.8 kg)	35.3 lb (16.0 kg)	35 lb (15.9 kg)	35.8 lb (16.2 kg)
MOUNTING CONFIGURATION				
Mounting: Set on shelf, wall mount with keyhole, or hang securely from ceiling.	•	•	•	•

EXPORT POWERDRIVE ONBOARD CHARGER SPECIFICATIONS	Export PowerDrive Onboard Battery Charger				
Model number (CCI P/N)	19710 (101964302)	17790-10 (101814302)	17790-20 (101814305)	17790-30 (101814306)	17790-40 (102546902)
AC INPUT					
AC voltage: 100, 200, 220, or 240 VAC (selectable)	•	•	•	•	•
AC voltage (acceptable range): at 100 VAC setting	95-105	95-105	95-105	95-105	95-105
AC voltage (acceptable range): at 200 VAC setting	190-210	190-210	190-210	190-210	190-210
AC voltage (acceptable range): at 220 VAC setting	209-231	209-231	209-231	209-231	209-231
AC voltage (acceptable range): at 240 VAC setting	228-252	228-252	228-252	228-252	228-252
Frequency: 50 Hz. / 60 Hz.	•	•	•	•	•
POWER CONSUMPTION					
Max. AC current (amps) at 100 VAC / 50 Hz.	13.6	13.6	13.6	13.6	13.6
Max. AC current (amps) at 100 VAC / 60 Hz.	12.4	12.4	12.4	12.4	12.4
Max. AC current (amps) at 200 VAC / 50 Hz.	6.9	6.9	6.9	6.9	6.9
Max. AC current (amps) at 200 VAC / 60 Hz.	6.3	6.3	6.3	6.3	6.3
Max. AC current (amps) at 220 VAC / 50 Hz.	6.9	6.9	6.9	6.9	6.9
Max. AC current (amps) at 220 VAC / 60 Hz.	6.3	6.3	6.3	6.3	6.3
Max. AC current (amps) at 240 VAC / 50 Hz.	5.9	5.9	5.9	5.9	5.9
Max. AC current (amps) at 240 VAC / 60 Hz.	5.1	5.1	5.1	5.1	5.1
DC OUTPUT					
DC voltage (VDC) (start of charge cycle)	48	48	48	48	48
DC current (amps) (start of charge cycle)	17	17	17	17	17
DC voltage (VDC) (end of charge cycle)	60	60	60	60	60
DC current (amps) (end of charge cycle)	3.5	3.5	3.5	3.5	3.5
DIMENSIONS/WEIGHT					
Case – overall length	11.75 in. (29.9 cm)	10.25 in. (26 cm)	10.25 in. (26 cm)	10.25 in. (26 cm)	10.25 in. (26 cm)
Case – overall width	7.25 in. (18.4 cm)	8.687 in. (22.1 cm)	8.687 in. (22.1 cm)	8.687 in. (22.1 cm)	8.687 in. (22.1 cm)
Case – overall height	9.5 in. (24.1 cm)	9.0 in. (22.9 cm)	9.0 in. (22.9 cm)	9.0 in. (22.9 cm)	9.0 in. (22.9 cm)
AC cord length	17 ft. (5.2 m) (retractable)	17 ft. (5.2 m) (retractable)	17 ft. (5.2 m) (retractable)	17 ft. (5.2 m) (retractable)	17 ft. (5.2 m) (retractable)
DC cord length	21.5 in. (54.6 cm)	80.5 in. (204.5 cm)	129.5 in. (328.9 cm)	162.5 in. (412.8 cm)	9.5 in. (24 cm)
Weight	37.0 lb (16.8 kg)	37.0 lb (16.8 kg)	40.5 lb (18.4 kg)	40.6 lb (18.4 kg)	40.6 lb (18.4 kg)
MOUNTING CONFIGURATION					
Mounting: Onboard (secured to the vehicle)	•	•	•	•	•

CLUB CAR[®] LIMITED FOUR YEAR WARRANTY FOR POWERDRIVE[®] CHARGERS

CLUB CAR, LLC, ("CLUB CAR") hereby warrants to the original retail purchaser that its new PowerDrive Chargers purchased from CLUB CAR or an authorized distributor or dealer will be free from defects in material and workmanship under normal use and service for a period of four years from the date of purchase, subject to the terms, provisions, limitations, and exclusions contained herein.

The limited warranty with respect to parts and labor only covers defects in material and workmanship for a period of four years from the date of purchase. Such repair labor shall be performed only by CLUB CAR or by an authorized distributor or dealer. Purchaser shall be responsible for all freight costs to and from CLUB CAR's facility.

LIMITED WARRANTY EXCLUSIONS

THE PROVISIONS OF THIS LIMITED WARRANTY SHALL NOT APPLY TO FAILURE DUE TO:

- 1) Lack of normal maintenance services such as preventive maintenance checks and tightening loose wire connections;
- 2) Semiconductor parts such as diodes and fuses which are vulnerable to electrical overloads (including lightning) beyond the control of CLUB CAR;
- 3) Charger DC cord set with plug, which is a wear item and subject to user abuse.

Any warranty service, which includes labor during the first year, must be performed by CLUB CAR or by an authorized distributor or dealer. For repairs made by qualified technicians other than CLUB CAR's factory technicians or an authorized distributor or dealer, CLUB CAR will provide only the replacement parts or components.

The PowerDrive Chargers are intended to be used by persons with knowledge of the chargers and proper charging practices and only on CLUB CAR PowerDrive System 48[™], PowerDrive Plus[®], and IQ System[™] vehicles. Any other use renders the Limited Warranties expressed herein and any implied warranties null and void and same are hereby excluded.

Without limiting the generality of the foregoing in any way, and as part of its limited warranty exclusion, CLUB CAR does not warrant that the PowerDrive Charger is suitable for use in any application other than its PowerDrive System 48, PowerDrive Plus, and IQ System products. As in the use of any electrical device, a prudent owner will read and study the charger owner's manual, the electric vehicle owner's manual, the operator instructions, and the battery warning labels; and will exercise due care in working on or around electrical devices.

Transportation expenses for warranty services are also excluded from this warranty.

WARRANTY LIMITATIONS

CLUB CAR's liability under this limited warranty, or in any action whether based upon warranty, contract, negligence, strict product liability or otherwise, shall be the replacement or repair of a charger or component thereof that CLUB CAR deems to be defective. Replacement shall mean furnishing, during the applicable limited warranty period, a new charger or component thereof that is identical or reasonably equivalent to the warranted product or defective component at no cost to the purchaser. Repair shall mean remedying a defect in the charger or component thereof at no cost to the purchaser during the applicable limited warranty period. If CLUB CAR elects to repair the charger, it may provide factory-reconditioned parts or components. All parts and components replaced under warranty shall become the property of CLUB CAR.

THIS LIMITED WARRANTY IS EXCLUSIVE. CLUB CAR MAKES NO OTHER WARRANTY OF ANY KIND, EXPRESSED OR IMPLIED. ANY IMPLIED WARRANTIES OF MERCHANTABILITY OR FITNESS FOR A PARTICULAR PURPOSE WHICH EXCEED THE OBLIGATIONS OR TIME LIMITS STATED IN THIS WARRANTY ARE HEREBY DISCLAIMED BY CLUB CAR AND EXCLUDED FROM THIS WARRANTY. THE PURCHASER AND CLUB CAR EXPRESSLY AGREE THAT THE REPLACEMENT OR REPAIR OF THE DEFECTIVE VEHICLE OR COMPONENT THEREOF IS THE SOLE REMEDY OF THE PURCHASER. CLUB CAR MAKES NO OTHER REPRESENTATION OR WARRANTY OF ANY KIND AND NO REPRESENTATIVE, EMPLOYEE, DISTRIBUTOR OR DEALER OF CLUB CAR HAS THE AUTHORITY TO MAKE OR IMPLY ANY REPRESENTATION, PROMISE OR AGREEMENT, WHICH IN ANY WAY VARIES THE TERMS OF THIS WARRANTY.

IN NO EVENT SHALL CLUB CAR BE LIABLE FOR ANY INCIDENTAL OR CONSEQUENTIAL DAMAGES INCLUDING, BUT NOT LIMITED TO, LOSS RELATED TO PROPERTY OTHER THAN THE BATTERY CHARGER, LOSS OF USE, LOSS OF TIME, INCONVENIENCE, OR ANY OTHER ECONOMIC LOSS.

Damage not resulting from a defect that occurs due to unreasonable use, abuse or neglect (including failure to provide reasonable or necessary maintenance), accident or alteration is excluded from the limited warranty.

Some states allow neither limitation on the duration of an implied warranty nor exclusions or limitations of incidental or consequential damages. Therefore, the above limitations or exclusions may not apply to you.

This warranty gives you specific legal rights, and you may also have other rights, which vary from state to state.

For further information contact WARRANTY SERVICES, CLUB CAR, LLC, P.O. Box 204658, Augusta, Georgia 30917-4658, U.S.A., 706-863-3000.

