

Alcoa
Fastening
Systems & Rings



INSTRUCTION MANUAL

MODEL 940

POWERIG® *HYDRAULIC UNIT*



Makers of Huck®, Marson®, Recoil®
Brand Fasteners, Tools & Accessories



August 6, 2015
HK496





NOTICE

*This manual applies to 940
serial number 3927 and above.*

*For any other serial numbers, please contact a Huck customer
service representative.*



CONTENTS

Safety	4
Description	5
Specifications	5
Principle of Operation	6
Preparation for Use	6
Checking and Adjusting Pressures	7
Operation	7
Maintenance	8
Assembly Reference Drawings	9-11
Powerig Options and Accessories	12
Troubleshooting	12



SAFETY INSTRUCTIONS

GLOSSARY OF TERMS AND SYMBOLS:



- Product complies with requirements set forth by the relevant European directives.



- **READ MANUAL** prior to using this equipment.



- **EYE PROTECTION IS REQUIRED** while using this equipment.



- **HEARING PROTECTION IS REQUIRED** while using this equipment.



WARNINGS: Must be understood to avoid severe personal injury.



CAUTIONS: show conditions that will damage equipment and or structure.

Notes: are reminders of required procedures.

Bold, Italic type and underlining: emphasizes a specific instruction.

1. A half hour long hands-on training session with qualified personnel is recommended before using Huck equipment.
2. Huck equipment must be maintained in a safe working condition at all times. Tools and hoses should be inspected at the beginning of each shift/day for damage or wear. Any repair should be done by a qualified repairman trained on Huck procedures.
3. Repairman and Operator must read manual prior to using equipment. Warning and Caution stickers/labels supplied with equipment must be understood before connecting equipment to any primary power supply. As applicable, each of the sections in this manual have specific safety and other information.
4. Read MSDS Specifications before servicing the tool. MSDS Specifications are available from the product manufacturer or your Huck representative.
5. When repairing or operating Huck installation equipment, always wear approved eye protection. Where applicable, refer to ANSI Z87.1 - 2003
6. Only genuine Huck parts shall be used for replacements or spares. Use of any other parts can result in tooling damage or personal injury.
7. If a part affixed with warning labels is replaced, or labels are missing or damaged, the end user is responsible for replacement. Refer to assembly drawing and parts list for replacement part number and proper placement.
8. Disconnect primary power source before performing maintenance on Huck equipment or changing Nose Assembly.
9. Tools and hoses should be inspected for leaks at the beginning of each shift/day. If any equipment shows signs of damage, wear, or leakage, do not connect it to the primary power supply.
10. Mounting hardware should be checked at the beginning of each shift/day.
11. Make sure proper power source is used at all times.
12. Release tool trigger if power supply is interrupted.
13. Tools are not to be used in an explosive environment unless specifically designed to do so.
14. Never remove any safety guards or pintail deflectors.
15. Where applicable, ensure deflector or pintail collector is installed and operating prior to use.
16. Never install a fastener in free air. Personal injury from fastener ejecting may occur.
17. Where applicable, always clear spent pintail out of nose assembly before installing the next fastener.
18. There is possibility of forcible ejection of pintails or spent mandrels from front of tool.
19. Check clearance between trigger and work piece to ensure there is no pinch point when tool is activated. Remote triggers are available for hydraulic tooling if pinch point is unavoidable.
20. Unsuitable postures may not allow counteracting of normal expected movement of tool.
21. Do not abuse tool by dropping or using it as a hammer. Never use hydraulic or air lines as a handle or to bend or pry the tool. Reasonable care of installation tools by operators is an important factor in maintaining tool efficiency, eliminating downtime, and in preventing an accident which may cause severe personal injury.
22. Never place hands between nose assembly and work piece. Keep hands clear from front of tool.
23. There is a risk of crushing if tool is cycled without Nose Assembly installed.
24. Tools with ejector rods should never be cycled with out nose assembly installed.
25. When two piece lock bolts are being used always make sure the collar orientation is correct. See fastener data sheet for correct positioning.
26. Tool is only to be used as stated in this manual. Any other use is prohibited.
27. There is a risk of whipping compressed air hose if tool is pneudraulic or pneumatic.
28. Release the trigger in case of failure of air supply or hydraulic supply.
29. Use only fluids or lubricants recommended.
30. Disposal instruction: Disassemble and recycle steel, aluminum and plastic parts, and drain and dispose of hydraulic fluid in accordance with local lawful and safe practices.
31. If tool is fixed to a suspension device, ensure that the device is secure prior to operating the tool.



DESCRIPTION

See Figures 1 & 5. Model 940 POWERIG® Hydraulic Unit is a portable, electrically operated power source designed to operate all Huck hydraulic installation equipment excluding Huck-Spin® tools. Model 940 operates on 115 volt AC, 50-60 Hz, one-phase electrical power. The **power cord** is a 10/3 SJTO cord with a NEMA L5-30 plug. The **motor** on the Powerig is rated at 115V, 50/60Hertz, 25A.

An **electrical enclosure** contains a motor contactor, transformer, relay and circuit breaker. Hydraulic pressure is developed by a two-stage, gear-piston **pump** driven by a 1 1/8 horsepower universal electric **motor**. Pressurized fluid is directed by a **four-way directional valve** to either the PULL or RETURN port of the installation equipment. The four-way directional valve is operated by a 24 volt AC control circuit. The **high pressure relief valve** controls PULL pressure

(maximum pressure of the unit) and is adjustable by the operator. An internal relief valve is preset at the factory to protect the Operator and equipment. The internal relief is not adjustable by the operator. A **pressure switch** controls RETURN pressure and turns off the POWERIG Hydraulic Unit at the end of an installation cycle. Pressures are adjustable to match Huck equipment being used. See applicable tool instruction manual for pressure settings for other Huck installation equipment.

Hydraulic fluid is stored in the **reservoir** which also serves as the base. Remove the **filler cap/dipstick** to check fluid level and to add fluid. **Hydraulic quick disconnect couplers** are furnished for connecting hoses from installation equipment.

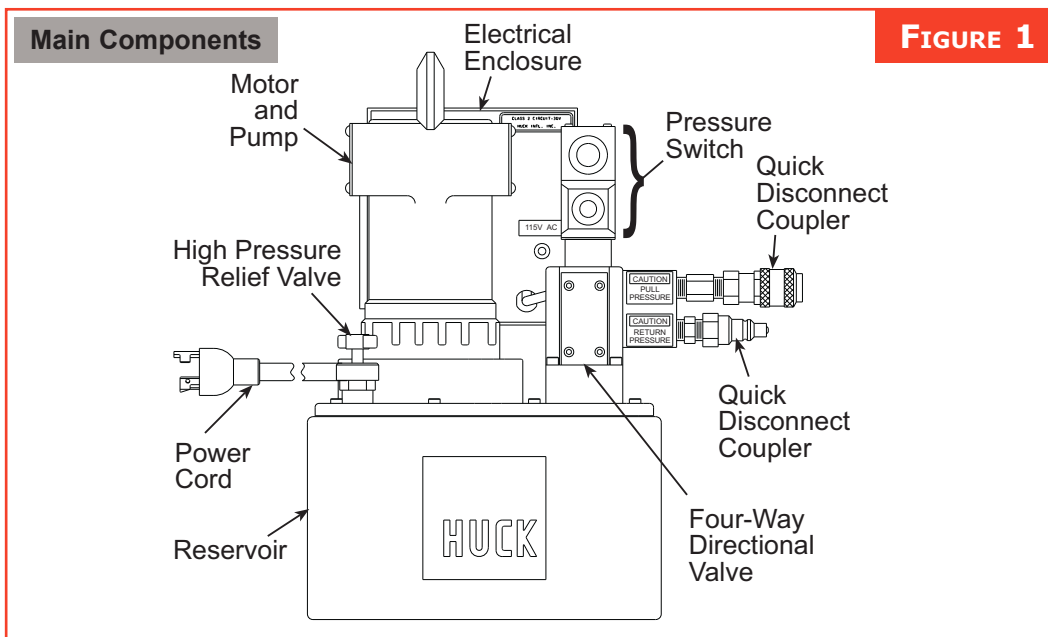

SPECIFICATIONS

CSA CERTIFIED

WIDTH: 16.1 inches (40.9 cm)

LENGTH: 13.9 inches (35.4 cm)

HEIGHT: 18.5 inches (47 cm)

WEIGHT: 66 pounds (30 kg) (with empty reservoir)

ELECTRICAL SYSTEM:

115VAC (25A), 50/60hz, single phase

CONTROL SYSTEM:

Solenoid operated directional valve, 24V

MOTOR:

12000 RPM, 1-1/8 HP, 25 amps. nominal

PUMP:

2-stage, gear-piston type, 70 in³/min @5,000 psi out pressure (Output pressure adjustable to 10,000 psi)

RESERVOIR CAPACITY: 2.6 gallons (9.8 liters)

PRESSURE SETTING AS SHIPPED:

RETURN: 2,200-2,400 psi (15,200-16,500 kPa)

PULL: 5,400 - 5,700psi (37,200 - 39,300 kPa)

Minimum Operating Temperature (ambient): 0° (18°C)

Maximum Hydraulic Fluid Temperature: 150°F (65°C)

HYDRAULIC FLUID: Hydraulic fluid shall meet DEXRON® III, DEXRON VI, MERCON, Allison C-4 or equivalent ATF specifications.

Fire resistant fluid may be used if it is an ester based fluid such as Quintolubric HFD or equivalent. Water based fluid shall NOT be used as serious damage to equipment will occur.

DEXRON is a registered trademark of General Motors Corporation.



PRINCIPLE OF OPERATION

FIGURE 2 shows the electrical schematic diagram of the POWERIG® Hydraulic Unit.

Pressure switch (PS) contacts are normally closed. Increasing pressure opens contacts.

When the tool trigger switch is depressed, 24 volts AC is applied between relay terminals CR13 and CR14 activating the relay coil and closing two sets of contacts, CR9-CR5 and CR12-CRS. Closing contacts CR9-CR5 starts the motor. Closing contacts CR12-CR8 activates the solenoid coil of the pilot valve. The pilot valve shifts the directional valve spools.

Pressurized fluid is directed to the PULL pressure port of the installation equipment.

When the tool trigger switch is released, the relay contacts open. The solenoid coil is dc-activated and the spring return of the pilot valve shifts the directional valve spools. Pressurized fluid is directed to the RETURN pressure port of the installation equipment.

The motor contactor is held closed until the preset RETURN pressure is reached and pressure switch (PS) contacts open. The motor turns off, the pressure drops, and pressure switch returns to the closed (normal) position.

Electrical Schematic Diagram

FIGURE 2

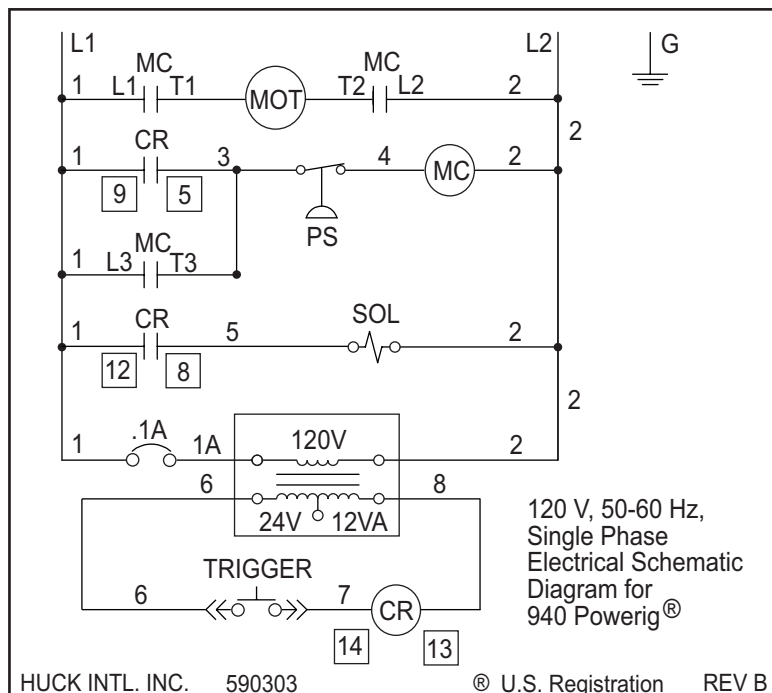

PREPARATION FOR USE

Service

Introduction of foreign material into Hydraulic Unit will result in poor performance and down time for repair. To avoid this, observe the following good practices:

Clean the area around the filler cap before adding hydraulic fluid.

Use a clean funnel with a filter.

Keep quick-disconnect couplers clean by keeping them off the floor. Wipe off quick-disconnect couplers before connecting them.

Before Use

Fill the reservoir with hydraulic fluid, approximately 2.6 gallons (9.8 liters), until the fluid level is between the grooves of the dipstick.

The POWERIG Hydraulic Unit is shipped without hydraulic fluid.



CHECKING AND ADJUSTING PRESSURES



WARNING: *Maximum PULL pressure is 8400 psi.* Refer to specific tool instruction manual for PULL and RETURN pressures. Severe personal injury may occur if excessive pressures cause violent failure of equipment. Higher than normal pressures will also cause premature wear of equipment.



WARNING: If recommended maximum pressure is exceeded, violent failure of fastening system may occur. This may cause severe personal injury.

CHECKING PRESSURES

Check **PULL** and **RETURN** pressures before use, before troubleshooting, and after overhauling. See pressures given in the specific tool instruction manual. For checking pressures, use **T-124833CE PRESSURE GAUGE** and **PRESSURE GAUGE INSTRUCTION MANUAL**.

ADJUSTING PRESSURES

NOTE: Use “T” gauge T-124833CE to check pressures during adjustment. Set pressures according to the specific installation equipment manual.

ADJUSTING PULL PRESSURE

NOTE: PULL pressure is the maximum POWERIG® pressure. Do not exceed the pressure rating of the

installation equipment. See the installation equipment manual for pressure rating.

- 1) Loosen the jam nut of the high pressure relief valve.
- 2) Turn the adjusting screw clockwise to increase PULL pressure **OR** counterclockwise to decrease PULL pressure.
- 3) Tighten the jam nut after PULL pressure has been adjusted.
- 4) Check PULL pressure. Follow instructions in the appropriate section of this manual.

ADJUSTING RETURN PRESSURE

- 1) Loosen the jam nut on pressure switch.
- 2) Turn the adjusting screw clockwise to increase RETURN pressure **OR** counterclockwise to decrease RETURN pressure.
- 3) Tighten the jam nut on pressure switch after return pressure has been adjusted.
- 4) Check RETURN pressure. Follow instructions in the appropriate section of this manual.

OPERATION

Before each use:

- 1) Check the fluid level in the reservoir and add hydraulic fluid as required.
- 2) Inspect hoses for damage and wear. If hoses show wear that has removed more than the surface texture, they must be replaced.
- 3) Check the entire system and repair any leaks.
- 4) Check electrical cord and extension for abrasion and replace as required.

Be sure that:

- 1) Hose from PULL PRESSURE on the control panel runs to the port stamped with a letter P on the tool.
- 2) Hose from RETURN PRESSURE on the control panel runs to the port stamped with letter R on the tool.

Plug the control cable from the tool into the two-prong socket on the POWERIG Hydraulic Unit control panel. Depress the tool trigger switch and let the POWERIG Hydraulic Unit operate for a few minutes to circulate fluid and remove air from the system.

Attach a nose assembly to the installation equipment. Fasteners may now be installed. Follow instructions in the tool manual.

Operating Tools

Plug the power cord into a grounded wall outlet.

Check pressures and adjust as necessary. See the appropriate sections in this manual. **WARNINGS must be understood before checking pressures.**

Connect hydraulic hoses from a HUCK hydraulic tool to the Powerig Hydraulic Unit.



MAINTENANCE

PARTS LIST

See Figures 3-6 for part numbers.

WIRING

See Figure 6 for wiring diagram and *TABLE 1* for wire list.

PREVENTIVE MAINTENANCE

An effective preventive maintenance program includes scheduled inspections to detect and correct minor troubles. Perform the following steps monthly during normal use:

Inspect hydraulic and electrical fittings to be sure they are secure.

Inspect hoses for signs of damage. Replace hoses if abrasion is deeper than the surface texture.

Rotate hoses end-for-end to equalize wear and fatigue.

Inspect during operation to detect any abnormal heating, vibration or leakage.

Inspect hydraulic fluid. If contamination (particles, water, sludge, etc.) is detected, clean the reservoir and replace fluid.

Clean exterior surfaces.

Check supply voltage. Do not operate the the POWERIG® Hydraulic Unit if the line voltage is more than 5 percent above or below 115 Volts.

SPARE PARTS

The quantity of spare parts that should be kept on hand varies with the application and number of the POWERIG Hydraulic Units in service. For directional valve and pilot valve maintenance, Seal Kit, 124100, should be kept on hand at all times. This kit contains O-rings and back-up rings required to service one directional valve and one pilot valve. Other parts that should be available to the service technician are: Pump to Motor Coupling, Relay, Transformer, Pilot Valve, and Motor Brushes.

DIRECTIONAL VALVE OVERHAUL

If minor overhaul of the directional valve (cleaning and replacing O-rings and back-up rings) is necessary, Seal Kit, 124100, is available. If major overhaul is necessary, return the directional valve to the nearest repair facility shown on the inside of the back cover.

Clean components in mineral spirits. Smear LUBRIPLATE 130AA, or equivalent, on O-rings and

mating surfaces to aid assembly and prevent damage to O-rings. LUBRIPLATE is trademarked and manufactured by Fiske Brothers Refining Co. and is available in most localities. A handy tube of LUBRIPLATE 130AA is available from Huck as part number 502723.

INTERNAL ADJUSTMENT OF PRESSURE SWITCH

1. Remove the top cover of the switch.
2. Loosen two screws located in the bottom of the switch housing.
3. Place a 0.20-inch-thick shim between the spring retainer and the platen.
4. Loosen the set screw on the spring retainer until it contacts shim.
5. Lock the spring retainer in place with the set screw.
6. Slide the switch mounting bracket toward the switch button until it contacts the platen surface.
7. Secure with two screws located in the middle of the bottom cover.
8. Connect a volt/ohm meter to the electrical cord.
9. Tighten the switch adjustment screw against the switch mounting bracket until the switch button contacts the platen and actuates. The volt/ohm meter will react when the button actuates. A click can be heard.
10. Continue tightening the switch adjustment screw 1/8 of a turn after the switch button actuates.
11. Replace the top cover of the switch.

REPLACING PUMP TO MOTOR COUPLING

The pump to motor coupling can be replaced by removing four socket cap screws holding the motor housing to the cover plate and lifting the motor to one side. Lift out the original coupling with needle-nose pliers. Drop in the new coupling, align the slots and reassemble motor to cover plate.

PUMP OVERHAUL

If pump requires overhaul return it, or the complete unit, to the nearest repair facility shown on the inside of the hack cover.



111345 PUMP, MOTOR, VALVE ASSEMBLY

FIGURE 4

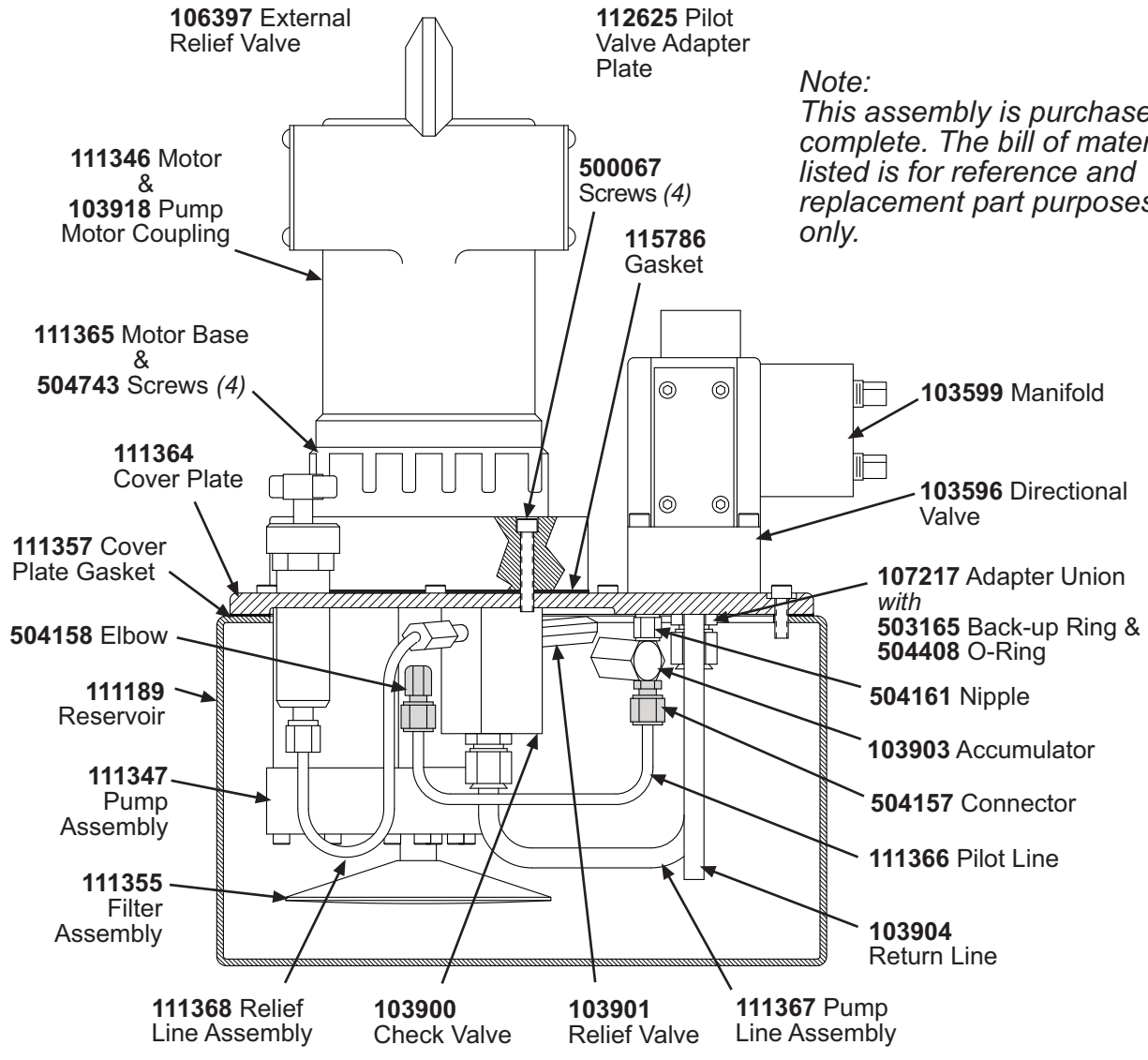
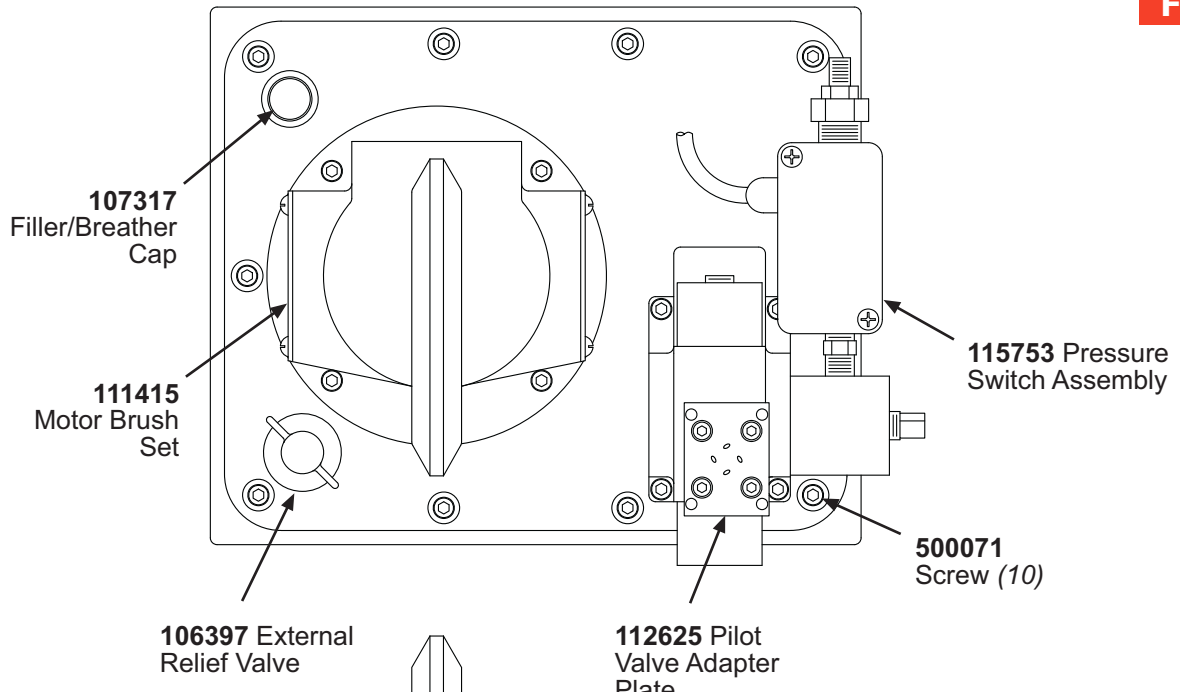

Note:
This assembly is purchased complete. The bill of material listed is for reference and replacement part purposes only.



123490 ELECTRICAL ENCLOSURE ASSEMBLY

FIGURE 5

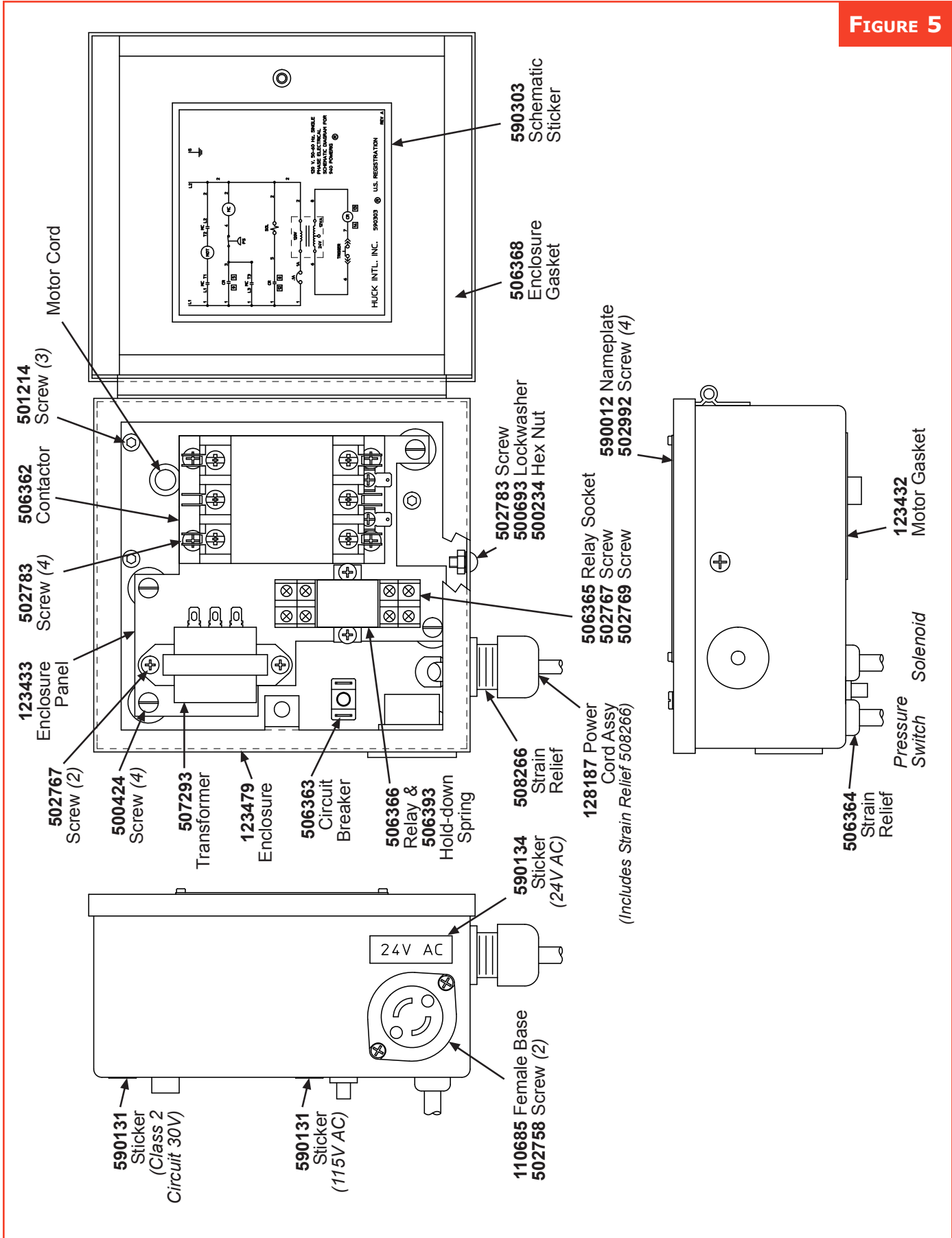



ELECTRICAL SCHEMATIC AND WIRING DIAGRAM

FIGURE 6

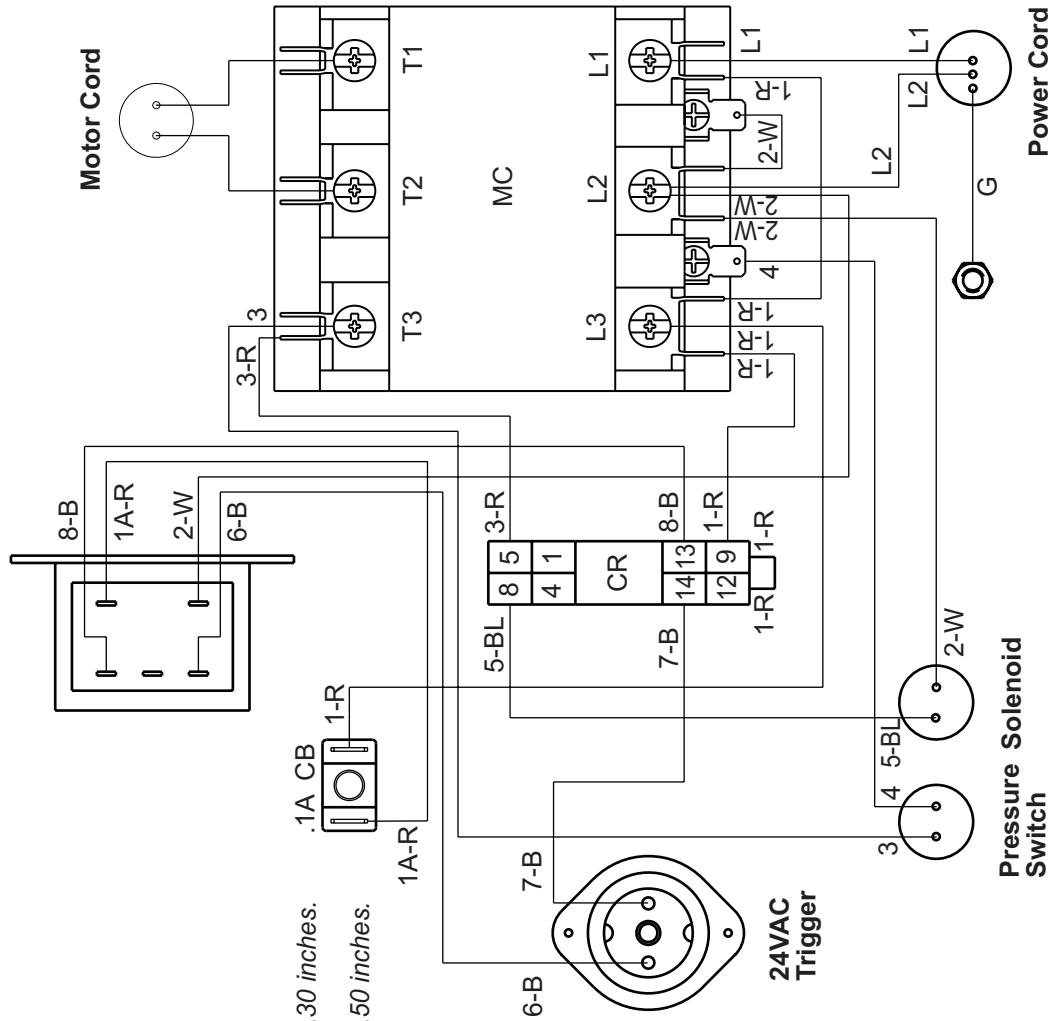

Notes:

1. Wire Label Code: XX - XX

- R = Red
- W = White
- B = Blue
- BL = Black

Indicates alphanumeric label to appear at both ends of the conductor.

2. Connections made to 506365 Socket Relay, strip end of wire 0.30 inches.

3. Connections made to 110685 Female Base, strip end of wire 0.50 inches.

4. Wire color code for Power Cord:

- L1 = Light Blue or Black
- L2 = Brown or White
- G = Green/Yellow or Green

5. Wire color code for Pressure Switch:

- 3 = Light Blue or Black
- 4 = Brown or White

TERMINAL	WIRE NUMBER LOCATION
505704	Power Cord L1 & L2 & G
505705	Pressure Switch 4
505744	Pressure Switch 3 & Motor Wires

Wire No.	Color	From	To
1A	red	transformer lower right	circuit breaker CR9
1	red	CR12	CR9
1	red	circuit breaker	MCL3
1	red	MCL1	MCL3
1	red	MCL3	CR9
2	white	MCL2	transformer lower left
2	white	MC terminal	MCL2
3	red	MCT3	CR5
6	blue	transformer upper left	trigger
7	blue	trigger	CR14
8	blue	transformer upper right	CR13



OPTIONS & ACCESSORIES

OPTIONS

940T-1 (Special Version of 940)

The 940T-1 is part of Huck's revised aftermarket Truck Kits, which contain different pressure installation tools. This hydraulic unit will be shipped from the factory with output pressures set as follows:

PULL: 5700-5800 psi **RETURN:** 4400-4600 psi

ACCESSORIES:

Auxiliary Switch and Control Cord 113056

An auxiliary switch is available for use when checking and adjusting pressures and when troubleshooting.

Gauge T-124833CE

A "T" gauge is available for use when checking and adjusting pressures, and troubleshooting.

Hose and Control Cord Kits of various lengths

Please contact your HUCK representative.

Directional Valve Seal Kit 124100

Includes seals necessary to service Directional Valve 103596.

Rig Transport Dolly 129703

Heavy duty steel dolly for easy movement of powerig throughout the work area.

Motor 111346

Motor and Pump Assembly 111345

Motor Service Kit 115770

includes:

Motor Brushes Set	111415
115V Armature	115764
Upper Bearing	115766
Lower Bearing	115767
115V Motor Field	115768
Brush Holder	115784
Brush Holder Cap	115785
Gasket	115786

TROUBLESHOOTING

Always check the simplest possible cause of malfunction first. For example, blown fuse, tripped circuit breaker, defective switch or control cord. Eliminate each possible cause until the defective circuit or part is located. Where possible, substitute known good parts for suspected bad parts. A qualified electrician should check out the electrical system. Use this section as an aid in locating trouble and correcting it.

1. Motor fails when tool switch is depressed:

- Loose or defective control cord or connectors.
- Power source not properly fused.
- Defective tool switch.
- Loose wire(s).
- Defective relay.
- Incorrect power source.
- Defective motor contactor.
- Defective transformer

2. Motor runs, but tool will not reciprocate:

- Hoses not coupled properly.
- Hydraulic fluid viscosity not proper or level is low.
- Defective pilot valve solenoid or coil.
- Unloading valve missing in tool.
- Bind in tool or nose assembly.
- Defective directional valve.
- Pump to motor coupling damaged.

3. Pintail of fastener fails to break off:

- PULL pressure set too low.
- Worn or defective hose couplers.
- Hydraulic fluid viscosity not proper or level is low.
- Hydraulic fluid overheated.
- Worn or defective directional valve.
- Internal relief valve set too low or defective.
- Worn or defective pump.

4. Tool will not return when switch is released. (Tool will not push nose assembly off swaged fastener.):

- RETURN pressure set too low.
- Hoses not coupled properly.
- Worn or defective solenoid.
- Worn or defective pilot valve.

5. Motor fails to shut-off when installation cycle is completed:

- RETURN pressure switch set too high.
- Hydraulic fluid viscosity not proper or level is low.
- Hydraulic fluid overheated.
- Defective limit switch in pressure switch assembly.

6. Pump making noise throughout entire cycle:

- Pump is cavitating-fluid level may be low or fluid viscosity too heavy.
- Strainer is dirty and clogged.

7. Tool operation slow; Entire cycle does occur:

- Pump is cavitating-fluid level may be low or fluid viscosity is too heavy.
- Strainer is dirty and clogged.
- Worn or defective directional valve.
- Worn or damaged pump.
- Worn or defective hydraulic couplers.



LIMITED WARRANTIES

TOOLING WARRANTY:

Huck warrants that tooling and other items (excluding fasteners, and hereinafter referred as “other items”) manufactured by Huck shall be free from defects in workmanship and materials for a period of ninety (90) days from the date of original purchase.

WARRANTY ON “NON STANDARD OR CUSTOM MANUFACTURED PRODUCTS”:

With regard to non-standard products or custom manufactured products to customer’s specifications, Huck warrants for a period of ninety (90) days from the date of purchase that such products shall meet Buyer’s specifications, be free of defects in workmanship and materials. Such warranty shall not be effective with respect to non-standard or custom products manufactured using buyer-supplied molds, material, tooling and fixtures that are not in good condition or repair and suitable for their intended purpose.

THERE ARE NO WARRANTIES WHICH EXTEND BEYOND THE DESCRIPTION ON THE FACE HEREOF. HUCK MAKES NO OTHER WARRANTIES AND EXPRESSLY DISCLAIMS ANY OTHER WARRANTIES, INCLUDING IMPLIED WARRANTIES AS TO MERCHANTABILITY OR AS TO THE FITNESS OF THE TOOLING, OTHER ITEMS, NONSTANDARD OR CUSTOM MANUFACTURED PRODUCTS FOR ANY PARTICULAR PURPOSE AND HUCK SHALL NOT BE LIABLE FOR ANY LOSS OR DAMAGE, DIRECTLY OR INDIRECTLY, ARISING FROM THE USE OF SUCH TOOLING, OTHER ITEMS, NONSTANDARD OR CUSTOM MANUFACTURED PRODUCTS OR BREACH OF WARRANTY OR FOR ANY CLAIM FOR INCIDENTAL OR CONSEQUENTIAL DAMAGES.

Huck’s sole liability and Buyer’s exclusive remedy for any breach of warranty shall be limited, at Huck’s option, to replacement or repair, at FOB Huck’s plant, of Huck manufactured tooling, other items, nonstandard or custom products found to be defective in specifications, workmanship and materials not otherwise the direct or indirect cause of Buyer supplied molds, material, tooling or fixtures. Buyer shall give Huck written notice of claims for defects within the ninety (90) day warranty period for tooling, other items, nonstandard or custom products described above and Huck shall inspect products for which such claim is made.

TOOLING, PART(S) AND OTHER ITEMS NOT MANUFACTURED BY HUCK:

HUCK MAKES NO WARRANTY WITH RESPECT TO THE TOOLING, PART(S) OR

OTHER ITEMS MANUFACTURED BY THIRD PARTIES. HUCK EXPRESSLY DISCLAIMS ANY WARRANTY EXPRESSED OR IMPLIED, AS TO THE CONDITION, DESIGN, OPERATION, MERCHANTABILITY OR FITNESS FOR USE OF ANY TOOL, PART(S), OR OTHER ITEMS THEREOF NOT MANUFACTURED BY HUCK. HUCK SHALL NOT BE LIABLE FOR ANY LOSS OR DAMAGE, DIRECTLY OR INDIRECTLY, ARISING FROM THE USE OF SUCH TOOLING, PART(S) OR OTHER ITEMS OR BREACH OF WARRANTY OR FOR ANY CLAIM FOR INCIDENTAL OR CONSEQUENTIAL DAMAGES.

The only warranties made with respect to such tool, part(s) or other items thereof are those made by the manufacturer thereof and Huck agrees to cooperate with Buyer in enforcing such warranties when such action is necessary.

Huck shall not be liable for any loss or damage resulting from delays or non-fulfillment of orders owing to strikes, fires, accidents, transportation companies or for any reason or reasons beyond the control of the Huck or its suppliers.

HUCK INSTALLATION EQUIPMENT:

Huck International, Inc. reserves the right to make changes in specifications and design and to discontinue models without notice.

Huck Installation Equipment should be serviced by trained service technicians only.

Always give the Serial Number of the equipment when corresponding or ordering service parts.

Complete repair facilities are maintained by Huck International, Inc. Please contact one of the offices listed below.

Eastern

One Corporate Drive Kingston, New York 12401-0250
Telephone (845) 331-7300 FAX (845) 334-7333

Outside USA and Canada

Contact your nearest Huck International Office, see back cover.

In addition to the above repair facilities, there are Authorized Tool Service Centers (ATSC’s) located throughout the United States. These service centers offer repair services, spare parts, Service Parts Kits, Service Tools Kits and Nose Assemblies. Please contact your Huck Representative or the nearest Huck office listed on the back cover for the ATSC in your area.

Alcoa Fastening Systems & Rings



One Great ConnectionSM

About Alcoa Fastening Systems & Rings

Alcoa Fastening Systems & Rings, a business unit of Alcoa, is a leading worldwide designer and manufacturer of fastening systems and rings, including specialty fasteners, fluid fittings, assembly components, installation

systems, and seamless rings for aerospace and industrial applications. Headquartered in Torrance, California, the company has over 8,300 employees at 39 manufacturing and distribution/logistics locations in 13 countries. For more information, visit afsr.alcoa.com

Alcoa Fastening Systems & Rings world-wide locations:

Americas

Aerospace Products

Tucson Operations

3724 East Columbia
Tucson, AZ 85714
800-234-4825
520-747-9898
FAX: 520-748-2142

Industrial Products

Kingston Operations

1 Corporate Drive
Kingston, NY 12401
800-278-4825
845-331-7300
FAX: 845-334-7333

Far East

Industrial Products

Australia Operations

14 Viewtech Place
Rowville, Victoria
Australia 3178
03-764-5500
Toll Free: 008-335-030
FAX: 03-764-5510

Europe

Industrial Products

United Kingdom Operations

Unit C, Stafford Park 7
Telford, Shropshire
England TF3 3BQ
01952-290011
FAX: 0952-290459

Aerospace Products

Carson Operations

PO Box 5268
900 Watson Center Rd.
Carson, CA 90749
800-421-1459
310-830-8200
FAX: 310-830-1436

Industrial Products

Latin America Operations

Avenida Parque Lira. 79-402
Tacubaya Mexico, D.F.
C.P. 11850
FAX: 525-515-1776
TELEX: 1173530 LUKSME

Aerospace Products

France Operations

Clos D'Asseville
BP4
95450 Us Par Vigny
France
33-1-30-27-9500
FAX: 33-1-34-66-0600

Industrial Products

Waco Operations

PO Box 8117
8001 Imperial Drive
Waco, TX 76714-8117
800-388-4825
254-776-2000
FAX: 254-751-5259



For The Long Haul, The Future of Fastening Technology, The Future of Assembly Technology, The Future of Tooling Technology, and Tools of Productivity are service marks of Huck International. Huck provides technical assistance regarding the use and application of Huck fasteners and tooling.

NOTICE: The information contained in this publication is only for general guidance with regard to properties of the products shown

and/or the means for selecting such products, and is not intended to create any warranty, express, implied, or statutory; all warranties are contained only in Huck's written quotations, acknowledgments, and/or purchase orders. It is recommended that the user secure specific, up-to-date data and information regarding each application and/or use of such products.

HWB898 1003-5M



For the Long Haul™