

# Practical Yield Line Design

An introduction to the practical use of Yield Line Theory in the design of economic reinforced concrete slabs, including examples of design of flat slabs, raft foundations and refurbishment

**G. Kennedy** MSc (Eng), CEng MICE

**C. H. Goodchild** BSc, CEng, MCI0B, MStructE

## Acknowledgements

Gerard Kennedy would like to acknowledge Trevor Powell, co-founder of Powell Tolner and Associates, for the encouragement and support given to him over the years in the application of Y.L.D.

Charles Goodchild would like to acknowledge that this publication would not have been possible without the enthusiasm and drive of Gerard Kennedy and other partners, notably John Sestak and staff at Powell Tolner and Associates, and for their tenacity in insisting that the commercial potential of Yield Line Design should be recognised and shared.

We would both like to thank the many individuals who contributed to this publication; amongst them:

Stuart Alexander  
K Baskaran  
Sharon Hart  
Tony Jones

John Morrison  
Bob Povey  
Cam Middleton  
Dr Chris Morley

Martin Southcott  
Alan Tovey  
Gillian Bond  
Issy Harvey

### Published by The Concrete Centre

Riverside House, 4 Meadows Business Park, Station Approach, Blackwater, Camberley, Surrey GU17 9AB

**Tel:** +44 (0)1276 606800 **Fax:** +44 (0)1276 606801

TCC/03/3

Published September 2004

ISBN 1-904818-08-0

Price Group L.

© The **Concrete** Centre

This publication was first made available on the website of the Reinforced Concrete Council. The RCC has now devolved and transferred to The **Concrete** Centre.

All advice or information from The **Concrete** Centre is intended for those who will evaluate the significance and limitations of its contents and take responsibility for its use and application. No liability (including that for negligence) for any loss resulting from such advice or information is accepted by The **Concrete** Centre or their subcontractors, suppliers or advisors. Readers should note that The **Concrete** Centre publications are subject to revision from time to time and should therefore ensure that they are in possession of the latest version.

# Practical Yield Line Design

## Contents

Notation.....	2
<b>1.0 Introduction</b>	
1.1 The essentials .....	3
1.2 Frequently asked questions .....	8
<b>2.0 The Work Method of analysis</b>	
2.1 General .....	22
2.2 The Work Method .....	23
2.3 Orthotropic slabs .....	38
<b>3.0 Standard formulae for slabs</b>	
3.1 One-way spanning slabs.....	45
3.2 Two-way spanning slabs.....	64
3.3 Two-way slabs - supports on 4 sides.....	66
3.4 Two-way slabs - supports on 3 sides .....	74
3.5 Two-way slabs - supports on 2 adjacent sides .....	84
3.6 Flat slabs (on a rectangular grid of columns) .....	88
<b>4.0 How to tackle . . . . .</b>	
4.1 Flat slabs: general .....	93
4.2 Flat slabs supported by rectangular grids of columns .....	98
4.3 Flat slabs on irregular grids of columns .....	120
4.4 Slabs with beams.....	127
4.5 Transfer slabs .....	135
4.6 Raft foundations .....	136
4.7 Refurbishments.....	143
<b>5.0 Case studies</b> .....	148
<b>6.0 Summary</b> .....	155
<b>7.0 References and further reading</b>	
7.1 References .....	156
7.2 Further reading .....	158
<b>Appendix</b> .....	160

# Notation

## Symbols

The symbols used in this publication have the following meaning:

Symbol	Description	Units
A	Area of column cross-section	m <sup>2</sup>
a, b, c	Plan dimensions of slab supported on several sides	m
D	Dissipation of internal energy	kNm
E	Expenditure of energy by external loads	kNm
g	Ultimate distributed dead load	kN/m <sup>2</sup>
g <sub>k</sub>	Characteristic distributed dead load	kN/m <sup>2</sup>
H <sub>1</sub> , H <sub>2</sub> ...	Holding down reaction at slab corner	kN
h <sub>1</sub> , h <sub>2</sub> ...	Yield line pattern defining dimension	m
i, i <sub>1</sub> , i <sub>2</sub> ...	Ratio of negative support moment to positive midspan moment, i.e. i <sub>1</sub> = m <sub>1</sub> '/m	
l	Length of a yield line (projected onto a region's axis of rotation)	m
L	Span (commonly edge to edge), distance,	m
m	Positive moment, i.e. the ultimate moment along the yield line (bottom fibres of slab in tension).	kNm/m
m', m <sub>1</sub> ', m <sub>2</sub> '	Negative moment, i.e. the ultimate moment along the yield line (top fibres of slab in tension).	kNm/m
mr	Ultimate moment of resistance (based on the steel provided)	kNm/m
n	Ultimate distributed load p + g	kN/m <sup>2</sup>
p	Ultimate distributed live load	kN/m <sup>2</sup>
p <sub>a</sub> , p <sub>b</sub>	Ultimate line load	kN/m
p <sub>k</sub>	Characteristic distributed live load	kN/m <sup>2</sup>
q <sub>1</sub> , q <sub>2</sub> ...	Ultimate support reaction	kN/m
S	Ultimate column reaction from slab tributary area	kN
s <sub>1</sub> , s <sub>2</sub>	Distance to point of contraflexure from support	m
x <sub>1</sub> , x <sub>2</sub>	Distance to section of max. positive moment from support	m
Δ δ <sub>max</sub>	Deflection, maximum deflection (usually taken as unity)	m
θ	Angle of rotation	m/m
n*	Adjusted ultimate distributed load (adjusted for light line loads through factors α and β).	kN/m <sup>2</sup>
ar, br	Reduced sides dimensions	m





## Drawing notation

The convention used in drawings and sketches is given below

### Supports

	Free edge		Continuous support
	Simple support		Column support

### Yield lines

	Positive (sagging) yield line, kNm/m		Axis of rotation
	Negative (hogging) yield line, kNm/m		Plastic hinge (in sectional elevation or in plan)

### Loads

	Line load, kN/m	+	Centre of gravity of load kN
P •	Point load, kN		

# 1.0 Introduction

## This publication

The aim of this publication is to (re-) introduce practical designers to the use of Yield Line Design. The intention is to give an overall appreciation of the method and comprehensive design guidance on its application to the design of some common structural elements. It assumes that the user has sufficient experience to recognise possible failure patterns and situations where further investigation is required.

The basic principles of Yield Line theory are explained and its application as a versatile method for the design and assessment of reinforced concrete slabs is demonstrated. Theory is followed by practical examples and the accompanying commentary gives insights into the years of experience brought to bear by the main author, Gerard Kennedy.

The publication is intended as a designer's aid and not an academic paper. It commits to paper a **practical** approach to the use of Yield Line for the design of concrete slabs. It gives guidance on how to tackle less simple problems, such as the design of flat slabs, rafts, refurbishment and slab-beam systems. Whilst the publication covers the design of common elements, it is an introduction, not a comprehensive handbook: ***in more exacting circumstances, designers are advised to consult more specialist literature.*** The examples are practical ones that may be followed, but should not be extended too far without reference to more specialist literature.

Yield Line Theory challenges designers to use judgement and not to rely solely on computer analysis and design. Once grasped, Yield Line Theory is exceedingly easy to put into practice and everyone in the procurement chain benefits. Simple design leads to simple details that are fast to detail and fast to fix. Current initiatives such as Egan [4] and partnering, etc, should challenge designers to revisit and re-evaluate the technique.

## 1.1 The essentials

### 1.1.1 What is Yield Line Design?

Yield Line Design is a well-founded method of designing reinforced concrete slabs, and similar types of elements. It uses Yield Line Theory to investigate failure mechanisms at the ultimate limit state. The theory is based on the principle that:

$$\text{work done in yield lines rotating} = \text{work done in loads moving}$$

Two of the most popular methods of application are the 'Work Method' and the use of standard formulae. This publication explains these two methods and illustrates how they may be used in the practical and economic design of reinforced concrete slabs such as flat slabs, raft foundations and refurbishments

### 1.1.2 What are the advantages of Yield Line Design?

Yield Line Design has the advantages of:

- Economy
- Simplicity and
- Versatility

Yield Line Design leads to slabs that are quick and easy to design, and are quick and easy to construct. There is no need to resort to computer for analysis or design. The resulting slabs are thin and have very low amounts of reinforcement in very regular arrangements. The reinforcement is therefore easy to detail and easy to fix and the slabs are very quick to construct. Above all, Yield Line Design generates very economic concrete slabs, because it considers features at the ultimate limit state.

Yield Line Design is a robust and proven design technique. It is a versatile tool that challenges designers to use judgement. Once grasped Yield Line Design is an exceedingly powerful design tool.

### 1.1.3 What is the catch?

Yield Line Design demands familiarity with failure patterns, i.e. knowledge of how slabs might fail. This calls for a certain amount of experience, engineering judgement and confidence, none of which is easily gained. This publication is aimed at 'experienced' engineers, who will recognise potential failure patterns. At the same time it is hoped that the publication will impart experience to younger engineers and encourage them to appreciate modes of failure and this powerful method of design.

Yield Line Design tends to be a hand method. This may be seen as both an advantage and disadvantage. Each slab has to be judged on its merits and individually assessed. The method allows complex slabs to be looked at in a simple way, and, in an age of computers, it gives an independent method of analysis and verification. This is especially important for those who are becoming disillusioned with the reliance placed on Finite Element Analysis. They see a need to impart greater understanding and remind designers that reinforced concrete does not necessarily behave in an elastic manner. Nonetheless it is hoped that the option of suitable and accessible software for Yield Line Design will become available in the near future.

Yield Line Design concerns itself with the ultimate limit state. It does not purport to deal with serviceability issues such as deflection per se. Nonetheless, deflection can be dealt with by simple formulae based on the yield moment. This publication shows how compliance with span-to-depth criteria may be achieved.

Column moments cannot be derived directly. They must be derived using separate elastic sub-frame analyses as is the case when using continuous beam analysis (assuming knife edge support), or by analysing separate yield line failure patterns discussed in section 4.17.

In the past Yield Line Design has been disadvantaged by half-truths and misrepresentations. Taking reasoned and pragmatic measures to overcome them easily dispels theoretical problems such as 'upper bound theory therefore unsafe'. These measures are discussed in this publication. This is perhaps the first time this practical approach has been set down in writing - advocates of Yield Line Design have been designing in this way for years.

### 1.1.4 Economy and simplicity

In slabs, Yield Line Design gives least weight reinforcement solutions coupled with least complication. These points were illustrated on the in-situ building of the European Concrete Building Project at Cardington [1] where, uniquely, many different methods of design and

**Table 1.1** Configurations of flexural reinforcement in the in-situ building at Cardington [1]

Floor no	Flexural reinforcement	Tonnes /floor*	Bar marks /floor
1	<i>Traditional loose bar - Elastic Design</i>	16.9	75
2	<i>Traditional loose bar - Elastic Design</i>	17.1	76
3	<i>Rationalised loose bar - Elastic Design</i>	15.3**	54
4	<i>Blanket cover loose bar - 1/2 Yield Line design - 1/2 Elastic Design</i>	14.5*	22
		23.2*	33
5	<i>One-way mats - Elastic Design</i>	19.9	42
6	<i>Blanket cover two-way mats - FE Design</i>	25.5	20
7	<i>Not part of the particular research project</i>		

\* Values given are for a whole floor.

\*\* 1.6T additional reinforcement would have been required to meet normal deflection criteria

detailing were carried out, constructed and compared. Yield Line Design was used on the 4<sup>th</sup> floor and required the least amount of reinforcement as shown in Table 1.1. This shows that for a complete floor, 14.5 tonnes of reinforcement would have been used using Yield Line Theory compared to 16.9 tonnes using more conventional elastic design methods.

The Yield Line Design at Cardington also led to very few bar marks being required: only the heavy blanket cover solution required fewer.

The economy of Yield Line Design is further illustrated in Figure 1.1, which shows the 4<sup>th</sup> floor at Cardington [1] during construction. The steel fixers are laying out the T12@200 B (565 mm<sup>2</sup>/m) reinforcement for the yield line half of the slab adjacent to the T16 @ 175 B (1148 mm<sup>2</sup>/m) in the elastically designed half towards the top of the picture. Each half of the slab performed well.



**Figure 1.1** European Concrete Building Project at Cardington - 4<sup>th</sup> floor during construction

*The half in the foreground was designed using Yield Line Design. The other elastically designed half was intended to be 'highly rationalised'. However, the number of bar marks used in the Yield Line Design was less than even the most rationalised of the Elastic Designs. It is worth noting that the deflections measured on the two halves under the same load were virtually identical.*

With Yield Line Theory the designer is in full control of how the moments are distributed throughout the slab. This leads to the opportunity to use simple reinforcement layouts – regular spacing of bars and fewer bar marks – that are easier for the designer, detailer, contractor and fixer. These arrangements are far more regular than with other methods of analysis such as Elastic or Finite Element Analysis.

These bar arrangements are premeditated and lead to the following advantages:

- For the detailer, regular layouts mean minimum numbers of bar marks. Often stock lengths can be specified.
- Drawings are quicker to produce, easier to detail and easier to read on site.
- Regular arrangements of reinforcement mean quicker fixing.
- The principles of simple reinforcement layouts are well suited to prefabrication of steel into welded mats and also to contractor detailing
- There is less chance of errors occurring
- Checking is easier.

## 1.1.5 The opportunity

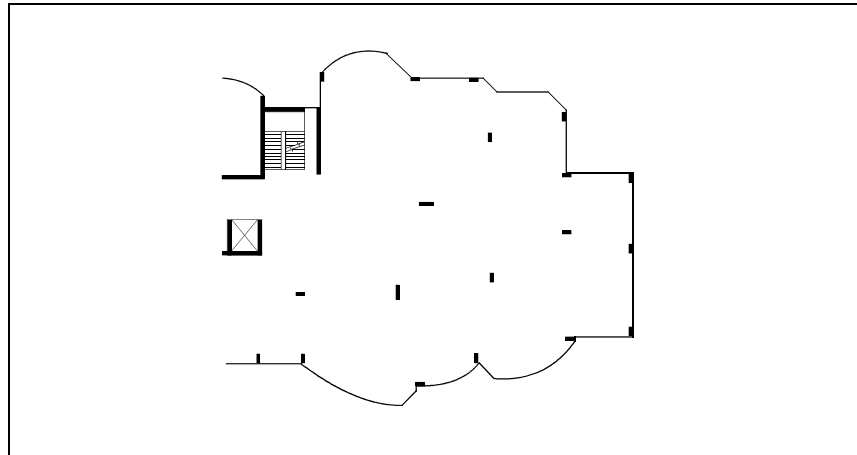
The management consultants who undertook research at Cardington [1] concluded: "Yield Line Design appears to provide a great opportunity for more competitive concrete building structures...."

## 1.1.6 Versatility

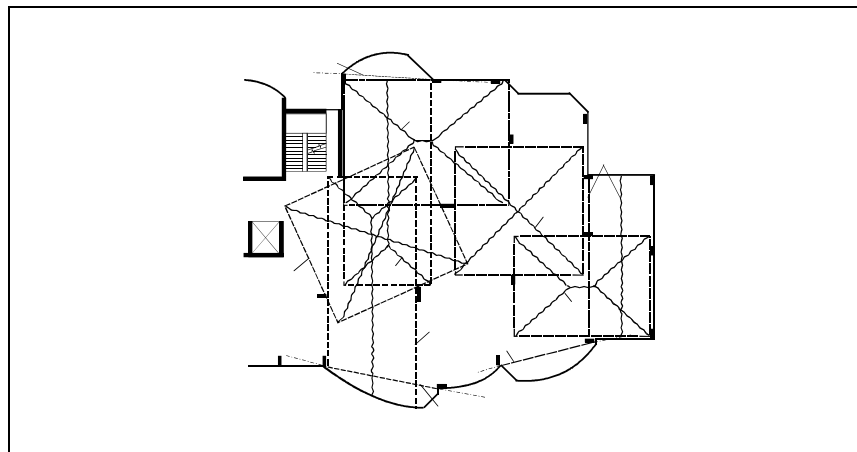
Once understood, Yield Line Design is quick and easy to apply. It may be used on all types of slab and loading configurations that would otherwise be very difficult to analyse without sophisticated computer programmes. It can deal with openings, holes, irregular shapes and with any support configuration. The slabs may be solid, voided, ribbed or coffered, and supported on beams, columns or walls.

The following are typical areas of application:

- An irregularly supported **flat slab** as shown in Figure 1.2, may, as illustrated by Figure 1.3 (and Section 4.3), be analysed by considering yield line patterns in the form of folded plates or worst-case quadrilaterals.



**Figure 1.2** An irregular flat slab....



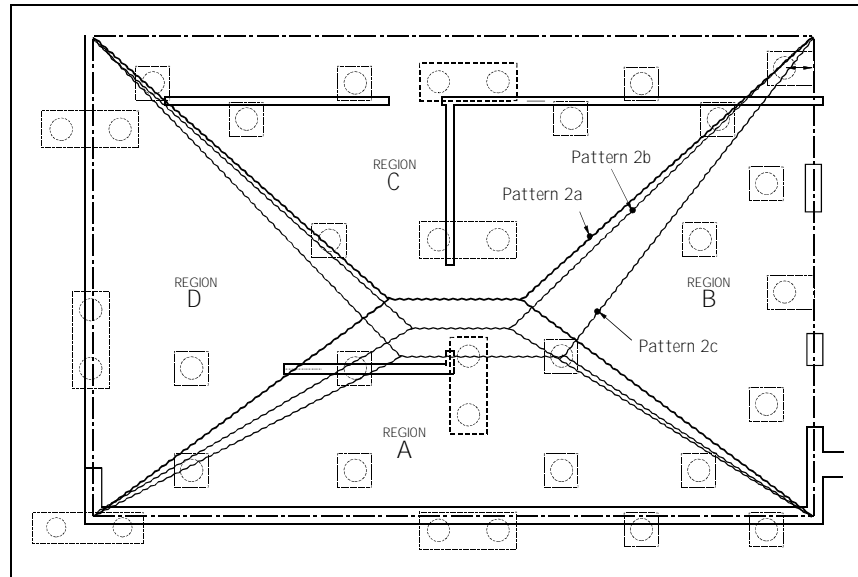
**Figure 1.3** .....may be analysed using Yield Line Design – by considering quadrilaterals

- Yield Line Theory can be used very effectively in **refurbishment** work. It is used in the assessment of existing slabs and can be especially useful where the support system is amended and/or new holes have to be incorporated. (New holes are dealt with by adjusting the length of postulated Yield Lines.) Yield Line Theory can be



used to estimate the ultimate load capacity of such slabs and so optimise and/or minimise structural works on site.

- The theory can be used to analyse slabs with beams: composite T and L beams may be incorporated into a combined collapse mechanism. Yield Line Theory is used effectively in the design and assessment of slabs in **bridges**.
- Yield Line Theory can also be applied to **slabs resting on soil**, i.e. industrial ground floor slabs, foundation rafts etc. The piled raft foundation illustrated in Figure 1.4 was analysed and designed using Yield Line Theory - simply and by hand (see Example 4F).



**Figure 1.4** A piled raft – easily dealt with using Yield Line Theory and Design

## 1.2 Frequently asked questions

Yield Line Design is easy to grasp but there are several fundamental principles that need to be understood. Yield Line Design is a plastic method: it is different from 'normal' elastic methods, and to help with the transition in the thought processes, definitions, explanations, main rules, limitations, etc have been gathered together here in this section

### 1.2.1 What is a yield line?

A yield line is a crack in a reinforced concrete slab across which the reinforcing bars have yielded and along which plastic rotation occurs.

### 1.2.2 What is Yield Line Theory?

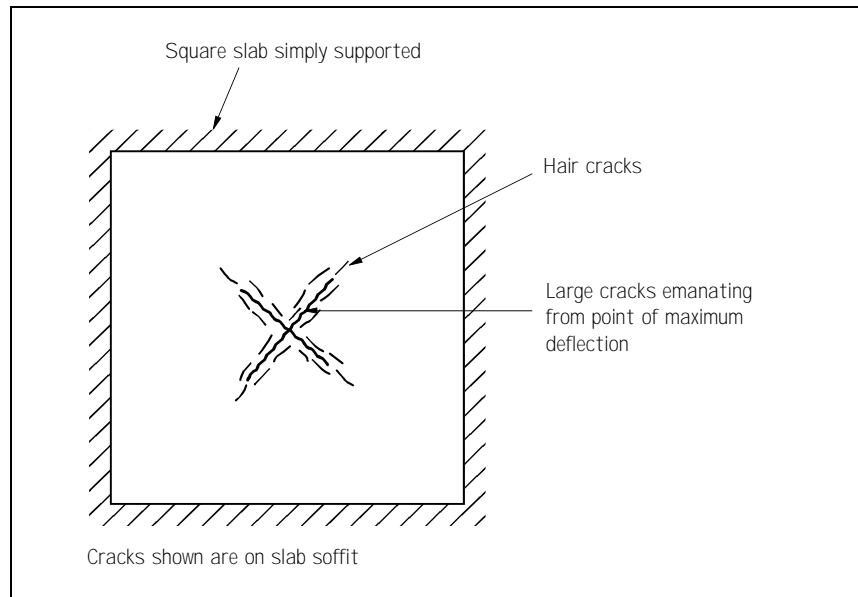
Yield Line Theory is an ultimate load analysis. It establishes either the moments in an element (e.g. a loaded slab) at the point of failure or the load at which an element will fail. It may be applied to many types of slab, both with and without beams.

Consider the case of a square slab simply supported on four sides as illustrated by Figure 1.5. This slab is subjected to a uniformly distributed load, which gradually increases until collapse occurs.

Initially, at service load, the response of the slab is elastic with the maximum steel stress and deflection occurring at the centre of the slab. At this stage, it is possible that some hairline cracking will occur on the soffit where the flexural tensile capacity of the concrete has been exceeded at midspan.

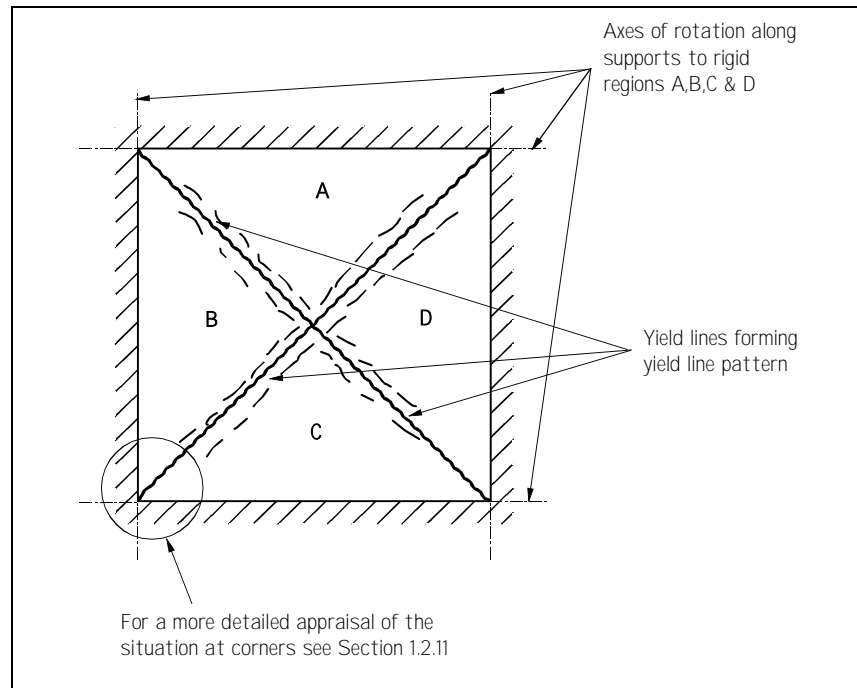
Increasing the load hastens the formation of these hairline cracks, Increasing the load further will increase the size of the cracks further and induce yielding of the reinforcement, initiating the formation of large cracks emanating from the point of maximum deflection.

On increasing the load yet further, these cracks migrate to the free edges of the slab at which time all the tensile reinforcement passing through a yield line yields.



**Figure 1.5** Onset of yielding of bottom reinforcement at point of maximum deflection in a simply supported two-way slab

At this ultimate limit state, the slab fails. As illustrated by Figure 1.6, the slab is divided into rigid plane regions A, B, C and D. Yield lines form the boundaries between the rigid regions, and these regions, in effect, rotate about the yield lines. The regions also pivot about their axes of rotation, which usually lie along lines of support, causing supported loads to move. It is at this juncture that the work dissipated by the hinges in the yield lines rotating is equated to work expended by loads on the regions moving. This is Yield Line Theory.



**Figure 1.6** The formation of a mechanism in a simply supported two-way slab with the bottom steel having yielded along the yield lines

Under this theory, elastic deformations are ignored; all the deformations are assumed to be concentrated in the yield lines and, for convenience, the maximum deformation is given the value of unity.

### 1.2.3 What is a yield line pattern?

When a slab is loaded to failure, yield lines form in the most highly stressed areas and these develop into continuous plastic hinges. As described above, these plastic hinges develop into a mechanism forming a yield line pattern.

Yield lines divide the slab up into individual regions, which pivot about their axes of rotation. Yield lines and axes of rotation conform to rules given in Table 1.2, which help with the identification of valid patterns and the Yield Line solution.

**Table 1.2** Rules for yield line patterns

- Axes of rotation generally lie along lines of support and pass alongside any columns.
- Yield lines are straight.
- Yield lines between adjacent rigid regions must pass through the point of intersection of the axes of rotation of those regions.
- Yield lines must end at a slab boundary.
- Continuous supports repel and simple supports attract positive or sagging yield lines.

### 1.2.4 What is a Yield Line solution?

In theory, there may be several possible valid yield line patterns that could apply to a particular configuration of a slab and loading. However, there is one yield line pattern that gives the highest moments or least load at failure. This is known as the yield line solution.

The designer has several ways of determining the critical pattern and ensuring safe design:

- From first principles, e.g. by using The Work Method
- Using formulae for standard situations.

It will be noted that valid yield line patterns give results that are either correct or theoretically unsafe. These 'upper bound solutions' can deter some designers but, as discussed later, this theoretical awkwardness is easily overcome by testing different patterns and by making suitable allowances (see 10% rule later).

### 1.2.5 How do you select relevant yield line patterns?

A yield line pattern is derived mainly from the position of the axes of rotation, (i.e. the lines of support) and by ensuring that the yield lines themselves are straight, go through the intersection of axes of rotation and end at the slab boundary, i.e. conform to the rules in Table 1.2. Some simple examples are shown in Figure 1.7. Considering a slab to be a piece of pastry laid over supports may help designers to visualise appropriate yield line patterns.

The aim of investigating yield line patterns is to find the one pattern that gives the critical moment (the highest moment or the least load capacity). However, an exhaustive search is rarely necessary and selecting a few simple and obvious patterns is generally sufficient as their solutions are within a few percent of the perfectly correct solution. Section 2.1.12 illustrates that absolute dimensional accuracy is unnecessary for engineering purposes.

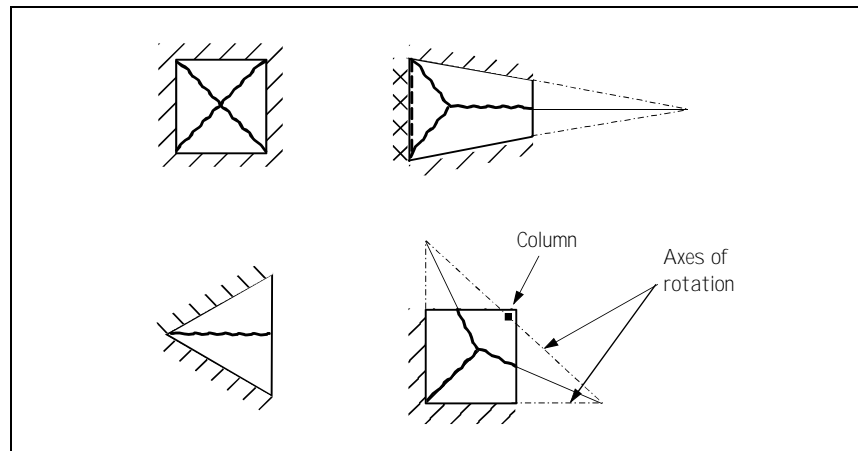
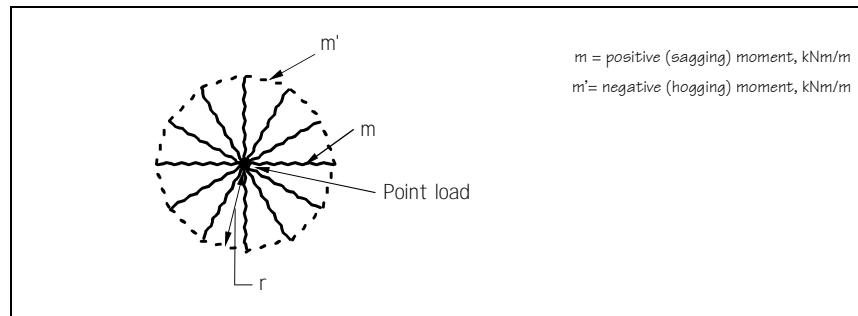


Figure 1.7 Simple Yield Line patterns

### 1.2.6 What is a fan mechanism?

Slabs subjected to heavy concentrated loads may fail by a so-called fan mechanism, with positive Yield Lines radiating from the load and a negative circular Yield Line centred under the point load. This mechanism is shown in Figure 1.8. It is rare for this form of failure to be critical but nonetheless a check is advised where large concentrated loads are present or for instance in flat slabs where the slab is supported on columns.



**Figure 1.8** Fan collapse pattern for a heavy concentrated load onto a reinforced slab

*The mechanism for a slab supported by a column is the same shape but with the positive and negative yield lines reversed.*

### 1.2.7 What is the Work Method?

The Work Method (or virtual Work Method) of analysis is the most popular (and most easy) way of applying Yield Line theory from first principles. Indeed, many experienced users of Yield Line theory of design choose to use the Work method because it is so very easy. The fundamental principle is that work done internally and externally must balance. In other words, at failure, the expenditure of external energy induced by the load on the slab must be equal to the internal energy dissipated within the yield lines. In other words:

External energy expended by loads moving	=	Internal energy dissipated by rotations about yield lines
Expended	=	Dissipated
E	=	D
$\Sigma (N \times \delta)$ for all regions	=	$\Sigma (m \times l \times \theta)$ for all regions

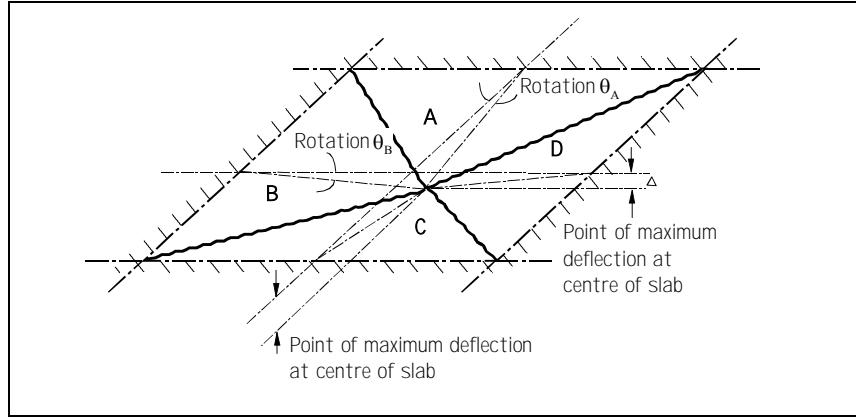
where

- N = load(s) acting within a particular region [kN]
- $\delta$  = the vertical displacement of the load(s) N on each region expressed as a fraction of unity [m]
- m = the moment in or moment of resistance of the slab per metre run [kNm/m]
- l = the length of yield line or its projected length onto the axis of rotation for that region [m]
- $\theta$  = the rotation of the region about its axis of rotation [m/m]

By way of illustration, consider the slab shown in Figure 1.6. Figure 1.9 shows an axonometric view of this two-way simply supported slab that has failed due to a uniformly distributed load. Note that:

- The triangular regions A, B, C and D have all rotated about their lines of support.
- The loads on the regions have moved vertically and rotation has taken place about the yield lines and supports.
- The uniformly distributed load on each of these regions will have moved on average 1/3 of the maximum deflection.

The rotation of the regions about the yield lines can be resolved into rotation about the principal axes of rotation, and thereby measured with respect to the location and size of the maximum deflection.



**Figure 1.9** Deformed shape at failure

This, fundamentally, is the 'Work Method'. Any slab can be analysed by using the principle of  $E = D$ . Some judgement is required to visualise and check likely failure patterns but absolute accuracy is rarely necessary and allowances are made to cover inaccuracies. Once a yield line pattern has been selected for investigation, it is only necessary to specify the deflection as being unity at one point (the point of maximum deflection) from which all other deflections and rotations can be found.

The Work Method is covered in more detail in Chapter 2.

### 1.2.8 Formulae

Rather than go through the Work Method, some practitioners prefer the even quicker method of using standard formulae for standard types of slab. The formulae are predominantly based on the work method and they are presented in more detail in Chapter 3.

As an example, the formula for one-way spanning slabs supporting uniformly distributed loads is as follows [2,6]:

$$m = \frac{nL^2}{2(\sqrt{1+i_1} + \sqrt{1+i_2})^2} \quad \text{per unit width}$$

where

$m$  = ultimate sagging moment along the yield line [kNm/m]

$m'$  = ultimate support moment along the yield line [kNm/m]

$n$  = ultimate load [kN/m<sup>2</sup>]

$L$  = span [m]

$i_1, i_2$  = ratios of support moments to mid-span moments. (The values of  $i$  are chosen by the designer:  $i_1 = m'_1/m$ ,  $i_2 = m'_2/m$ )

Where slabs are continuous, the designer has the freedom to choose the ratio of hogging to sagging moments to suit any particular situation. For instance, the designer may choose to make the bottom span steel equal to the top support steel (i.e. make sagging moment capacity equal support moment capacity.)

Failure patterns for one-way spanning slabs are easily visualised and the standard formulae enable the designer to quickly determine the span moment based on any ratio of hogging moments he or she chooses to stipulate (within a sensible range dictated by codes of practice). Formulae are also available for the curtailment of top reinforcement.

Formulae for two-way spanning slabs supported on two, three or four sides are also available for use. These are a little more complicated due to the two-way nature of the problem and the fact that slabs do not always have the same reinforcement in both directions. The nature of the failure patterns is relatively easy to visualise and again the designer has the freedom to choose fixity ratios.

The formulae are presented and discussed in Chapter 3.

### 1.2.9 Is Yield Line Theory allowable under design codes of practice?

Yes.

Any design process is governed by the recommendations of a specific code of practice. In the UK, BS 8110 [7] clause 3.5.2.1 says 'Alternatively, Johansen's Yield Line method ... may be used... for solid slabs'. The proviso is that to provide against serviceability requirements, the ratio of support and span moments should be similar to those obtained by elastic theory. This sub-clause is referred to in clauses 3.6.2 and 3.7.1.2 making the approach also acceptable for ribbed slabs and flat slabs.

According to Eurocode 2 [3], Yield Line Design is a perfectly valid method of design. Section 5.6 of Eurocode 2 states that plastic methods of analysis shall only be used to check the ultimate limit state. Ductility is critical and sufficient rotation capacity may be assumed provided  $x/d \leq 0.25$  for C50/60.<sup>A</sup> Eurocode 2 goes on to say that the method may be extended to flat slabs, ribbed, hollow or waffle slabs and that corner tie down forces and torsion at free edges need to be accounted for.

Section 5.11.1.1 of EC2 includes Yield Line as a valid method of analysis for flat slabs. It is recommended that a variety of possible mechanisms are examined and the ratios of the moments at support to the moment in the spans should lie between 0.5 and 2.

### 1.2.10 Yield Line is an upper bound theory

Yield line theory gives upper bound solutions - results that are either correct or theoretically unsafe, see Table 1.3. However, once the possible failure patterns that can form have been recognised, it is difficult to get the yield line analysis critically wrong

**Table 1.3** Upper and lower bound ultimate load theories

**Ultimate load theories** for slabs fall into two categories:

- upper bound (unsafe or correct) or
- lower bound (safe or correct).

**Plastic analysis** is either based on

- upper bound (kinematic) methods, or on
- lower bound (static) methods.

**Upper bound (kinematic) methods include:**

- plastic or yield hinges method for beams, frames and one-way slabs;
- **Yield Line Theory for slabs.**

**Lower bound (static) methods include:**

- the strip method for slabs,
- the strut and tie approach for deep beams, corbels, anchorages, walls and plates loaded in their plane.

<sup>A</sup> This relates to an ultimate moment,  $M_u \approx 110$  kNm in a 200 mm slab or an  $M_u/(bd^2f_k) \approx 0.100$ . For higher concrete strengths,  $x/d \leq 0.15$ ). Class B or C reinforcing steel must be used, i.e. characteristic strain at maximum force,  $\epsilon_{uk} \geq 5.0\%$ .

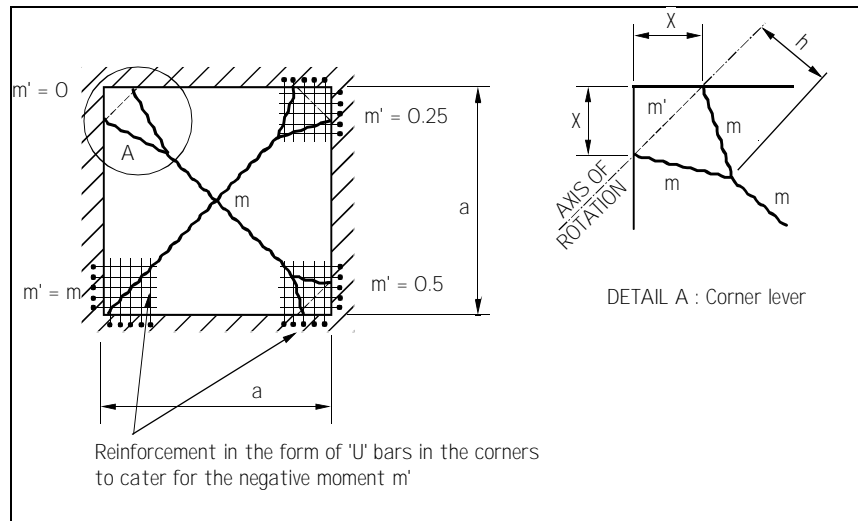
The mention of 'unsafe' can put designers off, and upper bound theories are often denigrated. However, any result that is out by a small amount can be regarded as theoretically unsafe. Yet few practising engineers regard any analysis as being absolutely accurate and make due allowance in their design. The same is true and acknowledged in practical Yield Line Design.

In the majority of cases encountered, the result of a Yield Line analysis from first principles will be well within 10%, typically within 5%, of the mathematically correct solution. The pragmatic approach, therefore, is to increase moments (or reinforcement) derived from calculations by 10%. This '10% rule' is expanded upon later. There are other factors that make Yield Line Design safer than it may at first appear, e.g. compressive membrane action in failing slabs (this alone can quadruple ultimate capacities), strain hardening of reinforcement, and the practice of rounding up steel areas when allotting bars to designed areas of steel required.

The practical designer can use Yield Line Theory with confidence, in the knowledge that he or she is in control of a very useful, powerful and reliable design tool.

### 1.2.11 Corner levers

'Corner levers' describes the phenomenon in two-way slabs on line supports where yield lines split at internal corners. This splitting is associated with the formation of a negative yield line across the corner which 'levers' against a corner reaction (or holding down force – see 3.2.2). Corner levers particularly affect simply supported slabs and Figure 1.10 shows the effect corner levers can have on a simply supported square slab. It should also be noted that the sagging moment  $m$  in an isotropic slab increases with decreasing corner fixity. Table 1.4 illustrates the effects of continuity on both the extent of the corner levers and on positive moments [13]. At an average fixity ratio of 1.0 the effects are minimal. Nonetheless, if the corners are left unreinforced, span moments increase.



**Figure 1.10** The effect of corner levers on a simply supported square slab where corners are held down and prevented from lifting.



**Table 1.4** Effects of corner continuity on corner levers in a simply supported square slab [13]

Corner fixity $i = m'/m$	$x$	$h$	$m$ [kNm/m]	Positive moment increase in the slab due to corner lever
0	0.159a	0.523a	$na^2/22$	9.0%
0.25	0.110a	0.571a	$na^2/23$	4.3%
0.50	0.069a	0.619a	$na^2/23.6$	1.7%
1.00	0	-	$na^2/24$	-

For simplicity in the analysis, yield line patterns are generally assumed to go into corners without splitting, i.e. corner levers are ignored and an allowance is made for this. This simplification is justified for three principle reasons:

- The error for neglecting corner levers is usually small.
- The analysis involving corner levers becomes too involved.
- Corner levers usually bring out the beneficial effects of membrane action that negate their impact.

All methods and formulae in this publication are based on straight-line crack patterns that go into the corners. The values of the moments obtained in this way are only really valid if the top reinforcement provided in the corners is of the same magnitude as the bottom steel provided in the span. If this is not the case, as generally assumed, then the straight-line pattern will not form and some type of corner lever will appear depending on the amount of top reinforcement provided, if any. This in turn leads to additional moment to be added to the calculated positive (sagging) moment.

The exact amount of increase depends on a number of parameters, but generally about 4% to 8% is assumed for rectangular two-way slabs. At worst, for simply supported square slabs, the increase is approximately 9%. The effects of corner levers in slabs supported on four sides diminishes in rectangular slabs and begin to die out at a ratio of sides greater than 3:1. In triangular slabs and slabs with acute corners, the straight-line mechanism into the corners can underestimate the positive moment by 30% 35%. The whole matter of corner levers is covered in some detail in Chapter II of *Plastic and elastic design of slabs and plates* [13] and chapter 12 of *Yield-Line Analysis of slabs* [14].

The effects of corner levers have to be recognised. For regular slabs their effects are allowed for within 'the 10% rule' – see below.

Despite this, it is good practice, and it is recommended, to specify and detail U-bars, equivalent to 50% of the span steel around all edges, including both ways at corners.

### 1.2.12 The 10% rule

**A 10% margin on the design moments should be added when using the Work Method or formulae for two-way slabs to allow for the method being upper bound and to allow for the effects of corner levers**

The addition of 10% to the design moment in two-way slabs provides some leeway where inexact yield line solutions have been used and some reassurance against the effects of ignoring corner levers (see above). At the relatively low stress levels in slabs, a 10% increase in moment equates to a 10% increase in the designed reinforcement.

The designer may of course chase in search of a more exact solution but most pragmatists are satisfied to know that by applying the 10% rule to a simple analysis their design will be on the safe side without being unduly conservative or uneconomic. The

10% rule can and usually is applied in other circumstances where the designer wants to apply engineering judgement and err on the side of caution.

The only situations where allowances under this '10% rule' may be inadequate relate to slabs with acute corners and certain configuration of slabs with substantial<sup>B</sup> point loads or line loads. In these cases guidance should be sought from specialist literature [5,6,14].

### 1.2.13 Serviceability and deflections

Yield Line Theory concerns itself only with the ultimate limit state. The designer must ensure that relevant serviceability requirements, particularly the limit state of deflection, are satisfied.

Deflection of slabs should be considered on the basis of *elastic* design. This may call for separate analysis but, more usually, deflection may be checked by using span/effective depth ratios with ultimate (i.e. yield line) moments as the basis. Such checks will be adequate in the vast majority of cases [8].

#### BS 8110

Deflection is usually checked by ensuring that the allowable span/effective depth ratio is greater than the actual span/ effective depth ratio (or by checking allowable span is greater than actual span). The basic span/depth ratio is modified by factors for compression reinforcement (if any) and service stress in the tension reinforcement. The latter can have a large effect when determining the service stress,  $f_s$ , to use in equation 8 in Table 3.10 of BS 8110 [7]. When calculations are based on the ultimate yield line moments, one can, conservatively, use  $\beta_b$  values of 1.1 for end spans and 1.2 for internal spans. This point is touched on in Example 3C and examined in the Appendix under Serviceability Moment.

Where estimates of actual deflections are required, other approaches, such as the rigorous methods in BS 8110 Part 2, simplified analysis methods [8] or finite element methods should be investigated. These should be carried out as a secondary check after the flexural design based on ultimate limit state principles has been carried out.

In order to keep cracking to an acceptable level it is normal to comply (sensibly) with the bar spacing requirements of BS 8110 Clauses 3.12.11.2.7 and 2.8.

#### Eurocode 2

Eurocode 2 treats deflection in a similar manner to BS 8110. Deemed-to-satisfy span-to-depth ratios may be used to check deflection. Otherwise calculations, which recognise that sections exist in a state between uncracked and fully cracked, should be undertaken.

#### Johansen

Johansen [6], who was responsible in large part for the development of Yield Line Theory, saw little point in making particularly accurate deflection calculations – it was more important to understand the magnitude of the deflection. One reason he cited was the variation in concrete's modulus of elasticity.

Johansen covered a number of situations that are difficult to analyse without resorting to finite element methods. For instance his method for checking deflection of a slab supported on two sides is used in the design of a balcony illustrated in Example 3G.

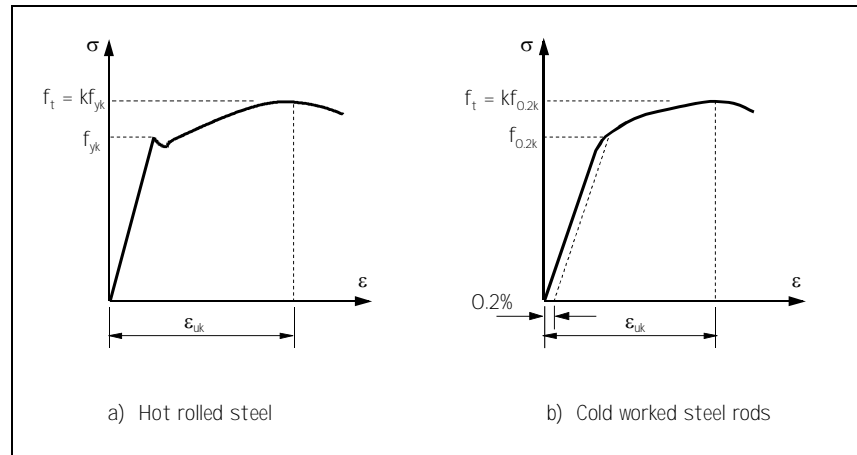
Johansen's formulae for one-way, two-way and flat slabs are given in the Appendix.

---

<sup>B</sup> Where, say  $\Sigma G_{\text{kpoint and line load}} > 1/3 (\Sigma G_{\text{kudl}} + \Sigma P_{\text{kudl}})$  more onerous local failure patterns could develop.

### 1.2.14 Ductility

Yield Line Theory assumes that there is sufficient ductility in the sections considered for them to develop their collapse mechanism through curvature and maintain their full ultimate moment of resistance along their entire length.



**Figure 1.11** Typical stress-strain diagrams of reinforcing steel [3]

More generally, ductility is important for two main reasons:

- safety – warning of collapse and
- economy – through load sharing.

The ductility of steel reinforcement is a familiar phenomenon. However, many factors affect ductility of reinforced concrete sections and unfortunately no simple analytical procedure has been devised to enable a required curvature or ductility factor to be calculated. [12]. Tests have shown that slabs generally have the required ultimate curvature capacity.

Nonetheless, to ensure adequate ductility, design codes generally restrict allowable  $x/d$  ratios and modern codes [3] restrict the types of reinforcing steel used to ensure that the reinforcement yields before concrete fails. Although BS 8110 [7] has no specific restrictions, Eurocode 2 [3] and others [12] recommend that Class 'B' and 'C' should be used with plastic analyses such as Yield Line Theory. In other words, elongation at maximum force,  $Agt(\%)$ , should be at least 5% and this may rule out cold drawn wire used in many meshes.

**Table 1.5** Minimum characteristic reinforcement strain at maximum stress

Class to EC2 Table C.1	A	B	C
Elongation at maximum force $Agt(\%)$ ( $\equiv$ Characteristic strain at maximum force, $\epsilon_{uk}$ )	$\geq 2.5$	$\geq 5.0$	$\geq 7.5$

### 1.2.15 Flat slabs

Flat slabs on regular supports are regarded as being one-way spanning slabs in each of two directions. Flat slabs on irregular supports should be checked critically for one-way plate failures and should also be investigated by applying the Work Method to worst case failure patterns. In each case, local fan yield line failure mechanisms over columns are checked – but due to the usual practice of concentrating top reinforcement over columns, they are rarely critical. These slabs are also checked for punching shear and deflection in the usual manner. The design is explained in more detail in Sections 4.1 to 4.3.

Yield Line Design produces very economic sections and enables very rational layouts of reinforcement in flat slabs. CIRIA Report 110 [38] on design of flat slabs, says "The Yield-Line method of analysing slabs results in the most economic arrangements of reinforcement, and it gives close agreement with the actual behaviour of slabs at collapse conditions." More recently, it has been recognised that "to compete, design engineers would do well to increase their use of Yield Line, which remains the best way to design flat slabs" [9].

Yield line methods are used to ensure realistic factors of safety against collapse but as discussed above, should not be used to check deflection (or punching shear). Deflection should be checked using span/effective depth ratios. If estimates of deflection are required, the reader is referred to other methods and other publications [8].

Punching shear can control the thickness of flat slabs. However, assuming punching reinforcement is acceptable, the thickness of contemporary flat slabs is most often controlled by deflection. To help with punching shear, the designer may choose to concentrate most (sometimes all) of the top reinforcement required in a bay close to the column and so maximise the value of allowable design concrete shear stress local to the column.

## 1.2.16 Some other technical questions answered

### Isotropy

An isotropic slab is one with the same amount of **bottom** reinforcement both ways, and, by assuming effective depths are equal, moment capacities in the two directions are equal, i.e.  $m_x = m_y$ . They are easily dealt with and are the subject of most of the text in this and other publications on yield line analysis and design

For convenience in design, the effective depth,  $d$ , is assumed to be equal both ways and is taken as being at the interface of the two layers.

### Orthotropy and Affine transformations

Orthotropic slabs have different amounts of reinforcement in the two directions. Very often there is no need for the reinforcement in two-way rectangular slabs to be the same in two directions. These slabs tend to span in the short direction and this direction will have the greater requirement for reinforcement.

The analysis of such slabs can be done using affine transformations. In these the stronger direction is assumed to have the moment capacity,  $m$ , and in the weaker direction the capacity of the slab is assumed to be  $\mu m$ . The value of  $\mu$  is usually based on the relative amounts of reinforcement the designer wishes to use in the two directions. In an affine transformation,  $\mu$  and  $\sqrt{\mu}$  are used to modify the dimensions and concentrated loads on the slab so that the orthotropic slab transforms to, and can be treated as, an equivalent isotropic slab of modified dimensions and loading. As an isotropic slab, all the usual formulae and methods for dealing with two-way slabs thus become available and are valid. Section 2.3 illustrates the technique.

### Superimposition of loads

Unlike elastic methods, Yield Line Theory is non-linear and the principle of superimposition of loads is strictly inapplicable. However, the sum of the ultimate moments for a series of loads is greater than the ultimate moment for all the loads at one time. So for a complicated load arrangement, a conservative solution may be found by summing moments from individual loads.

The accuracy of the resulting moment depends on how divergent the individual Yield Line patterns are. The more divergent these patterns are from each other the less accurate the result i.e. the greater the conservatism of the result.

### Other methods

The authors acknowledge that there are a number of other ways of applying Yield Line Theory. Some of these are described in the Appendix. The methods advocated in this publication are based on those of Jones and Wood [14] and are considered to be easy to grasp and easy to use commercially.

## 1.2.17 Some other applications

Besides the design of normally reinforced concrete suspended slabs, Yield Line Theory may be applied in a number of other areas:

### Slabs on grade

Industrial ground floor slabs are traditionally designed using either the Westergaard or Meyerhof methods. While Westergaard uses elastic theory, the more up-to-date methods advocated by Meyerhof and his successors Losberg and Weisgerber depend on the Yield Line Theory [26, 34, 39, 40, 41].

Consider a concentrated load applied to the top of a ground-supported slab. As the load increases tensile stresses are induced in the bottom of the slab, giving rise to radial cracking emanating from the point of application of the load. These radial cracks increase in length until the bending stresses along a circumferential section of the slab become equal to the flexural strength of the concrete and a circumferential tension crack is formed on the top, at which point failure is assumed to have occurred. The formula that Johansen [6] used, and which his successors later extended, to establish the collapse load  $P_u$  in flexure is:

$$P_u \left( 1 - \sqrt[3]{\frac{\sigma_p}{p_c}} \right) = 2\pi(m + m')$$

Where

$m, m'$  are the sagging and hogging flexural moments of resistance of the slab respectively.

$\sqrt[3]{\frac{\sigma_p}{p_c}}$  represents the resistance of the soil (this term is usually ignored).

Where

$\sigma_p$  The plastic modulus of subgrade reaction (conservatively the elastic modulus of subgrade reaction might be used).

$p_c$  is the stress on the slab under the contact area of the concentrated load

If the resistance of the soil to the slab failure is ignored the formula simplifies to

$$P_u = 2\pi(m + m')$$

These particular formulae apply only when the load is far enough from any edge not to be influenced by it. (See formulae presented in Tables 3.10 and 3.11.)

Although, conventionally, mesh reinforcement is ignored with respect to flexural capacity of the slab, reinforcement can be used to increase capacity but adequate ductility of the section would need to be assured. Research in connection with updating Concrete Society TR 34 [26] has shown that adequate ductility **is** available, allowing a new design method to be advocated. Concretes with steel fibres have been shown to give sufficient ductility to allow some redistribution of moment.

In the design of these slabs, punching shear and serviceability issues of surface cracking, deflection, joints and surface regularity also need to be addressed.

### Post-tensioned flat slabs

The design of suspended post-tensioned flat slabs comes down to the checking the following:

- stresses in concrete and steel,
- the serviceability limit states of cracking, deflection and vibration,
- detail design and
- the ultimate limit states of flexure and punching

at various stages of construction and use. Yield Line Theory may be applied when considering the ultimate limit state of flexure [42].

Post-tensioned slabs may use bonded or unbonded tendons with normal reinforcement supplementing the top of the slab around columns over an area of approximately  $0.4L \times 0.4L$  and the bottom of the slab in end bays by between 0.05 to 0.15% to limit the size and distribution of cracks.

### Concrete bridges

Yield Line Theory is used in the assessment of short span reinforced concrete and post-tensioned in-situ concrete bridges. Dr L A Clark [36] concluded that, from the considerable amount of both theoretical and experimental research carried out on the application of Yield Line Theory to short to medium span concrete slab bridges, good agreement had been obtained between measured collapse loads and those predicted by Yield Line Theory. More recently a new technique for performing Yield Line analysis has been developed [35]. This is implemented in a computer program called COBRAS. This approach provides a simple, rapid and practical means of performing Yield Line analysis of bridges.

### Concrete bunkers

Yield Line Theory has also been used quite extensively in the design of concrete plate elements that are required to withstand the forces generated by explosions in both domestic and military applications.

### Steelwork connections

Yield Line theory may be used for the sizing steel plates in bolted connections, which are subjected to out of plane forces. Steel is a material ideally suited to the plastic redistribution of stresses.

### Masonry walls

In the design of masonry structures the Code of Practice [43] allows the use of Yield Line Theory for the design of walls subject to lateral loading, even though masonry is a brittle non-homogeneous material. When walls were tested to failure the collapse loads were compatible with the loads predicted by the theory.

## 1.2.18 A short history of Yield Line Theory

Yield Line Theory as we know it today was pioneered in the 1940s by the Danish engineer and researcher K W Johansen [5,6]. As early as 1922, the Russian, A Ingerslev [15] presented a paper to the Institution of Structural Engineers in London on the collapse modes of rectangular slabs. Authors such as R H Wood [13,14], L L Jones [14,16], A Sawczuk and T Jaeger [17], R Park [11], K O Kemp [18], C T Morley [19], M Kwiecinski [20] and many others, consolidated and extended Johansen's original work so that now the validity of the theory is well established making Yield Line Theory a formidable international design tool. In the 1960s 70s and 80s a significant amount of theoretical work on the application of Yield Line Theory to slabs and slab-beam structures was carried out around the world and was widely reported.

To support this work, extensive testing was undertaken to prove the validity of the theory [21 - 25]. Excellent agreement was obtained between the theoretical and experimental

Yield Line patterns and the ultimate loads. The differences between the theory and tests were small and mainly on the conservative side. In the tests where restraint was introduced to simulate continuous construction, the ultimate loads reached at failure were significantly greater than the loads predicted by the theory due to the beneficial effect of membrane forces.

## 2.0 The Work Method of analysis

### 2.1 General

The Work Method of analysis is one-way, probably the most popular way of applying Yield Line Analysis to analyse slabs from first principles. It is considered to be the quickest way of analysing a slab using hand calculations only. It can be applied and used on slabs of any configuration and loading arrangement.

The only prerequisite is that the designer has a reasonably good idea of the modes of failure and the likely shape of the crack pattern that will develop at failure. This is not as difficult as it sounds. Having studied the basic failure patterns that are formed by the majority of slab shapes encountered in practice, the designer soon develops a feel for the way a slab is likely to fail and the confidence to turn this feel into safe and practical designs. Provided the numeric methods shown below are used, and, if necessary, iterations made, the Work Method gives solutions that are, almost always, within 10% of that attained by an exact algebraic approach using a differentiation process. In recognition of this possible inexactness, it is recommended that 'the 10% rule' (see Chapter 1) be applied.

#### 2.1.1 Caveat

In order to present the principles of the Work Method in simple terms, the text in this chapter is (and the application of this chapter should be) restricted to 'normal' rectangular slabs with reinforcement in two directions at right angles to each other and parallel with the sides of the slab. The sides of the slab form the axes of rotation of the individual rigid regions.

This restriction is not that onerous as it probably covers the vast majority of situations likely to occur in practice. However once the principles for these slabs are understood it is a small step to extend this to other cases. A more generalised treatise of this subject is given in Chapter 3 of Wood and Jones' *Yield-line analysis of slabs* [14].

#### 2.1.2 Preface

Before explaining how to apply the Work Method of analysis it may help to review the stages involved in the failure of a slab:

- Collapse occurs when yield lines form a mechanism.
- This mechanism divides the slab into rigid regions.
- Since elastic deformations are neglected these rigid regions remain as plane areas.
- These plane areas rotate about their axes of rotation located at their supports.
- All deformation is concentrated within the yield lines: the yield lines act as elongated plastic hinges.



## 2.2 The Work Method

### 2.2.1 Principles

As explained in Chapter 1, the basis of the Work Method is simply that at failure the potential energy expended by loads moving must equal the energy dissipated (or work done) in yield lines rotating. In other words:

External energy expended by the displacement of loads	=	Internal energy dissipated by the yield lines rotating
Expended	=	Dissipated
<b>E</b>	=	<b>D</b>
$\Sigma (N \times \delta)$ for all regions	=	$\Sigma (m \times l \times \theta)$ for all regions

where

- N is the Load(s) acting within a particular region [kN]
- $\delta$  is the vertical displacement of the load(s) N on each region expressed as a fraction of unity<sup>C</sup> [m]
- m is the moment or moment of resistance of the slab per metre run represented by the reinforcement crossing the yield line [kNm/m<sup>D</sup>]
- l is the length of yield line or its projected length onto the axis of rotation for that region [m]
- $\theta$  is the rotation of the region about its axis of rotation [m/m]

Once a valid failure pattern (or mechanism) has been postulated, either the moment, m, along the yield lines or the failure load of a slab, N (or indeed n kN/m<sup>2</sup>), can be established by applying the above equation.

This, fundamentally, is the Work Method of analysis: it is a kinematic (or energy) method of analysis.

### 2.2.2 Quantifying E

The external energy expended, E, is calculated by taking, in turn, the resultant of each load type (i.e. uniformly distributed load, line load or point load) acting on a region and multiplying it by its vertical displacement measured as a proportion of the maximum deflection implicit in the proposed yield line pattern. For simplicity, the maximum deflection is taken as unity, and the vertical displacement of each load is usually expressed as a fraction of unity. The total energy expended for the whole slab is the sum of the expended energies for all the regions.

### 2.2.3 Quantifying D

The internal energy dissipated, D, is calculated by taking the projected length of each yield line around a region onto the axis of rotation of that region, multiplying it by the moment acting on it and by the angle of rotation attributable to that region. The total energy dissipated for the whole slab is the sum of the dissipated energies of all the regions.

<sup>C</sup> The maximum deflection occurring at a point located on the yield line pattern is given an arbitrary displacement which for convenience is give the value of unity i.e. one metre. From this all the other displacements anywhere within the slab boundary are geometrically uniquely defined and expressed as a fraction of this theoretical one metre. This does not mean slabs deflect one metre! A value of 1 millimetre could be used but it would be less convenient in calculations. The value is purely arbitrary and does not really matter as  $\delta_{\max}$  cancels out with the fraction of  $\delta_{\max}$  on the other side of the equation.

<sup>D</sup> It can be seen that the resultant unit for the moment 'm' acting on a yield line is 'kN'. This is because the moment is always considered acting over one metre length of yield line.

Diagonal yield lines are assumed to be made up of small steps with sides parallel to the axes of rotation of the two regions it divides. The 'length' of a diagonal or inclined yield line is taken as the summation of the projected lengths of these individual steps onto the relevant axes of rotation.

The angle of rotation of a region is assumed to be small and is expressed as being  $\delta_{max}/\text{length}$ . The length is measured perpendicular to the axis of rotation to the point of maximum deflection of that region.

### 2.2.4 E = D

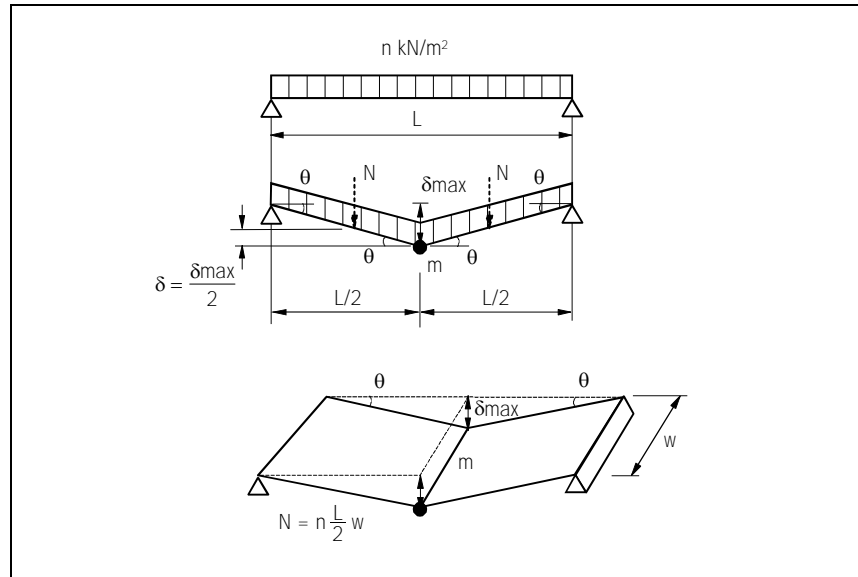
A fundamental principle of physics is that energy cannot be created or destroyed. So in the yield line mechanism,  $E = D$ . By equating these two energies the value of the unknown i.e. either the moment,  $m$ , or the load,  $N$ , can then be established.

If deemed necessary, several iterations may be required to find the maximum value of  $m$  (or the minimum value of load capacity) for each chosen failure pattern.

### 2.2.5 The principles

To illustrate the principles, two straightforward examples are presented.

Consider a one-way slab simply supported on two opposite sides, span,  $L$  and width  $w$ , supporting a uniformly distributed load of  $n \text{ kN/m}^2$ .



**Figure 2.1** A simply supported one-way slab

$$E = D$$

$$\sum(N \times \delta) = \sum(m \times l \times \theta)$$

$$2 \times n \times \frac{L}{2} \times w \times \frac{\delta_{max}}{2} = 2 \times m \times l \times \theta$$

Here, the length of the projected yield line, 'l', onto the axis of rotation is  $w$ . Also  $\theta$ , equates to  $\delta_{max}/(L/2)$ .

Therefore:

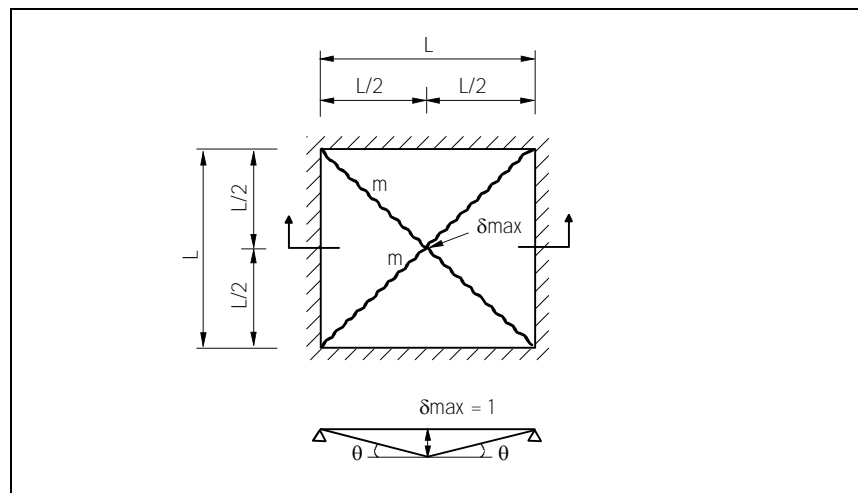
$$\frac{2nLw}{2} \times \frac{\delta_{\max}}{2} = 2mw \times \frac{\delta_{\max}}{L/2}$$

Cancelling gives:  $\frac{2nL}{4} = \frac{4m}{L}$

Rearranging gives:  $m = nL^2/8$

Which is rather familiar!

The same principles apply to two-way spanning slabs. Consider a square slab simply supported on four sides. Increasing load will firstly induce hairline cracking on the soffit, then large cracks will form culminating in the yield lines shown in Figure 2.2.



**Figure 2.2** Simply supported slab yield line pattern

*Diagonal cracks are treated as stepped cracks, with the yield lines projected onto parallel axes of rotations*

Assuming the slab measures  $L \times L$  and carries a load of  $n \text{ kN/m}^2$ :

$$E = D$$

$$\Sigma(N \times \delta) = \Sigma(m \times l \times \theta)$$

$$4 \times L \times \frac{L}{2} \times \frac{1}{2} \times n \times \frac{\delta_{\max}}{3} = 4 \times m \times L \times \frac{\delta_{\max}}{L/2}$$

In this case the length of the projected yield line,  $l$ , for each region measured parallel to the axis of rotation =  $L$

$$\frac{4L^2n}{12} = 8m$$

$$\frac{nL^2}{24} = m$$

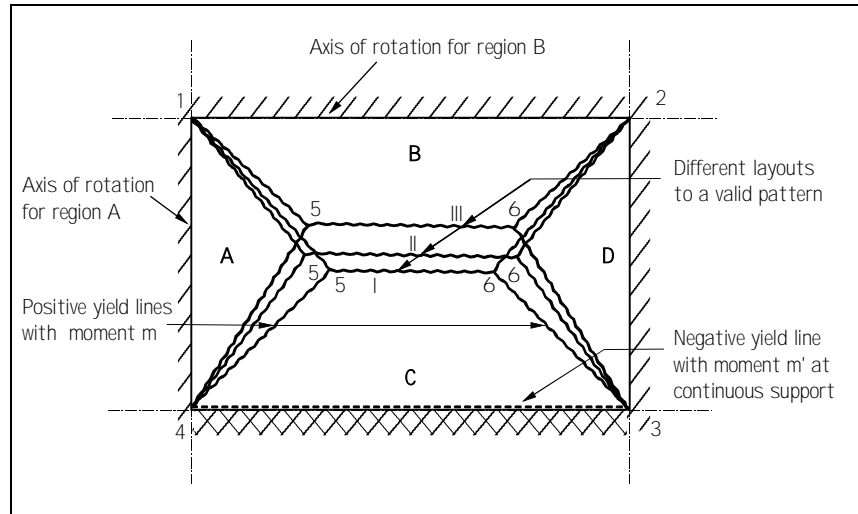
## 2.2.6 Rules for yield line patterns

There are rules to be observed when postulating a yield line pattern. As given in Table 1.2, they are as follows:

1. Axes of rotation generally lie along lines of support and pass over any columns.
2. Yield lines are straight.
3. Yield lines between adjacent rigid regions must pass through the point of intersection of the axes of rotation of those regions.
4. Yield lines must end at a slab boundary.
5. Continuous supports repel and a simple supports attract yield lines

Once a yield line pattern has been postulated it is only necessary to specify the deflection at one point (usually the point of maximum deflection) from which all other rotations can be found.

These rules are illustrated in Figures 2.3 and 2.4.



**Figure 2.3** Valid patterns for a two-way slab

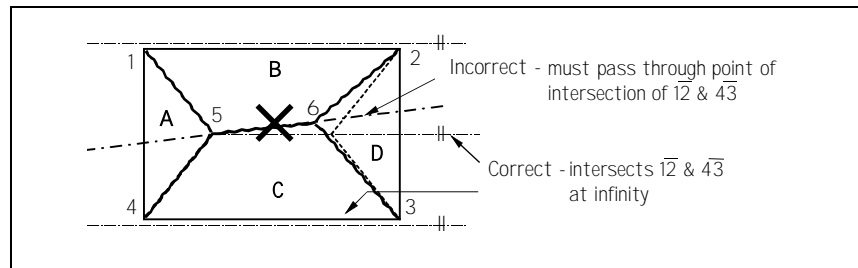
Figure 2.3 shows a slab with one continuous edge (along 3-4) and simply supported on the other three sides. The figure shows three variations of a valid yield line pattern. Successive applications of the Work method would establish which of the three would produce the most unfavourable result.

In this pattern, line 5-6 would be given unit deflection and this would then define the rotations of all the regions.

On the basis that a continuous support repels and a simple support attracts yield lines, layout III is most likely to be closest to the correct solution. As region C has a continuous support (whereas region B has not), line 5-6, must be closer to support 1-2 than support to 3-4.

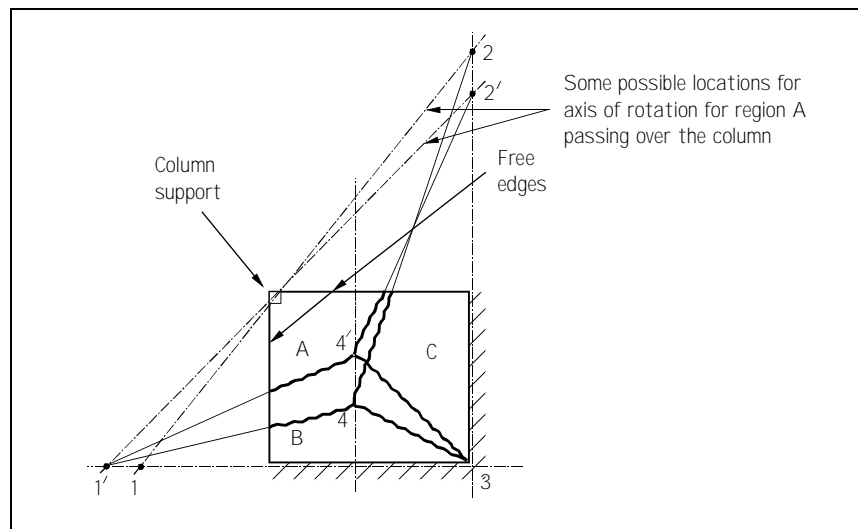
It is always important to ensure that Rule 3 (Yield lines between adjacent rigid regions must pass through the point of intersection of the axes of rotation of those regions) is observed in establishing a valid pattern. For the case under consideration, line 1-5, for instance, passes through the intersection of the axes of rotation of the adjacent regions A & B. Similarly line 2-6 passes through the intersection of the axes of rotation of adjacent regions B and D. Likewise line 5-6 in Figure 2.3: this line intersects the axes of rotation of

adjoining regions B & C at infinity, i.e. line 5-6 is parallel to the axes of rotation. This is clearly not the case in Figure 2.4 and so the pattern in Figure 2.4 is incorrect.

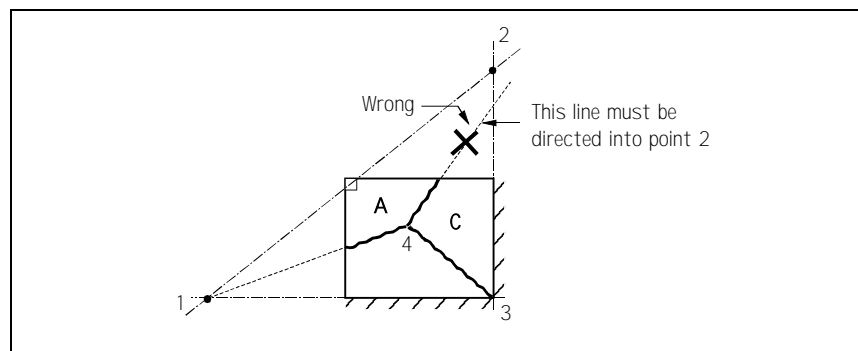


**Figure 2.4** Invalid pattern for the two-way slab above

Figures 2.5 and 2.6 show the correct and incorrect application of Rule 3 to a slab supported on two adjacent edges and a column.



**Figure 2.5** Valid patterns for a slab supported on two adjacent edges and a column. The rules for yield line patterns apply to columns as well as wall supports. As illustrated by lines 1-2 and 1'-2', appropriate axes of rotation for maximum moment,  $m$ , might not be quite so obvious, but it is rarely necessary to be exactly accurate. In the detailed analysis of slabs on walls and columns, it is usual to take axes of rotation on the faces of supports.

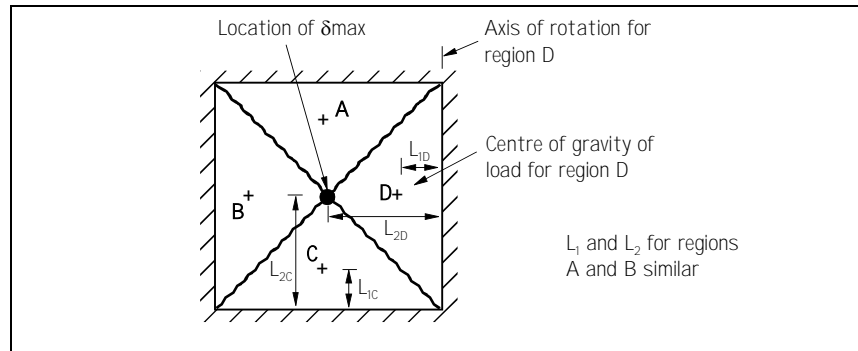


**Figure 2.6** An invalid pattern

## 2.2.7 General simplification

In any yield line pattern there is an assumed point of maximum deflection  $\delta_{max}$ , and this is always assigned the value of unity i.e.  $\delta_{max} = 1$ . In the case of a rectangular slab  $\delta_{max}$  may extend along a central yield line. Generally, the maximum deflection is the same for all the regions of a slab (i.e.  $\delta_{max\ region} = \delta_{max} = 1$ ). Thus, when calculating the Expended external energy,  $E$ , the displacement of the resultant of each load acting on a region can be simply expressed as a factor of  $L_1/L_2$  where:

- $L_1$  is the perpendicular distance of the resultant force from the axis of rotation of the region
- $L_2$  is the perpendicular distance to the location of  $\delta_{max}$  from the axis of rotation of the region



**Figure 2.7** Lengths  $L_1$  and  $L_2$

The axis of rotation of the region usually coincides with the supported edge. Whereas  $L_2$  is a constant value for all loads on a region, the distance  $L_1$  will depend on the location of the centroid of the loads acting within that region. This leads to the following values of  $L_1/L_2$  when dealing with uniformly distributed loads:

- $1/2$  for all rectangular regions
- $1/3$  for all triangular regions with apex at point of max. deflection
- $2/3$  for all triangular regions with apex on the axis of rotation

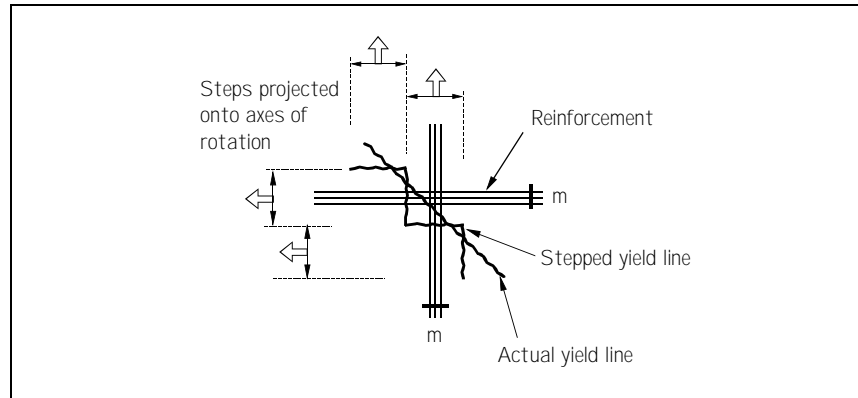
In carrying out the calculations for expenditure of external energy,  $E$ , the loads for all the triangular areas can be expressed as a single total load, rather than working out each load separately, as they all have equal displacement. In a similar way, all rectangular areas will have equal displacement.

For dissipated internal energy,  $D$ , once a yield line pattern has been postulated, it is only necessary to specify the deflection of one point (usually the point of maximum deflection) from which all rotations can be determined. Thus a factor of  $1/L_2$  is used to determine  $\theta_i$ , where:

- $\theta_i$  is the rotation of the region about its axis of rotation
- $L_2$  as before, is the distance normal from the axis of rotation (or supported edge) to the location of  $\delta_{max}$  of that region. This distance can vary for each region.

## 2.2.8 Angled yield lines

Yield lines that divide regions at an angle to the reinforcement are, for the purpose of analysis, considered as yield lines in small steps at right angles to the reinforcement: for convenience the angled yield line is resolved in two directions. Thus a diagonal yield line is considered as being projected in two directions onto the axes of rotation of the two regions being divided. These projected lengths form parts of the overall yield line lengths (also see Figure 2.11).



**Figure 2.8** Dealing with angled yield lines

## 2.2.9 Design procedure

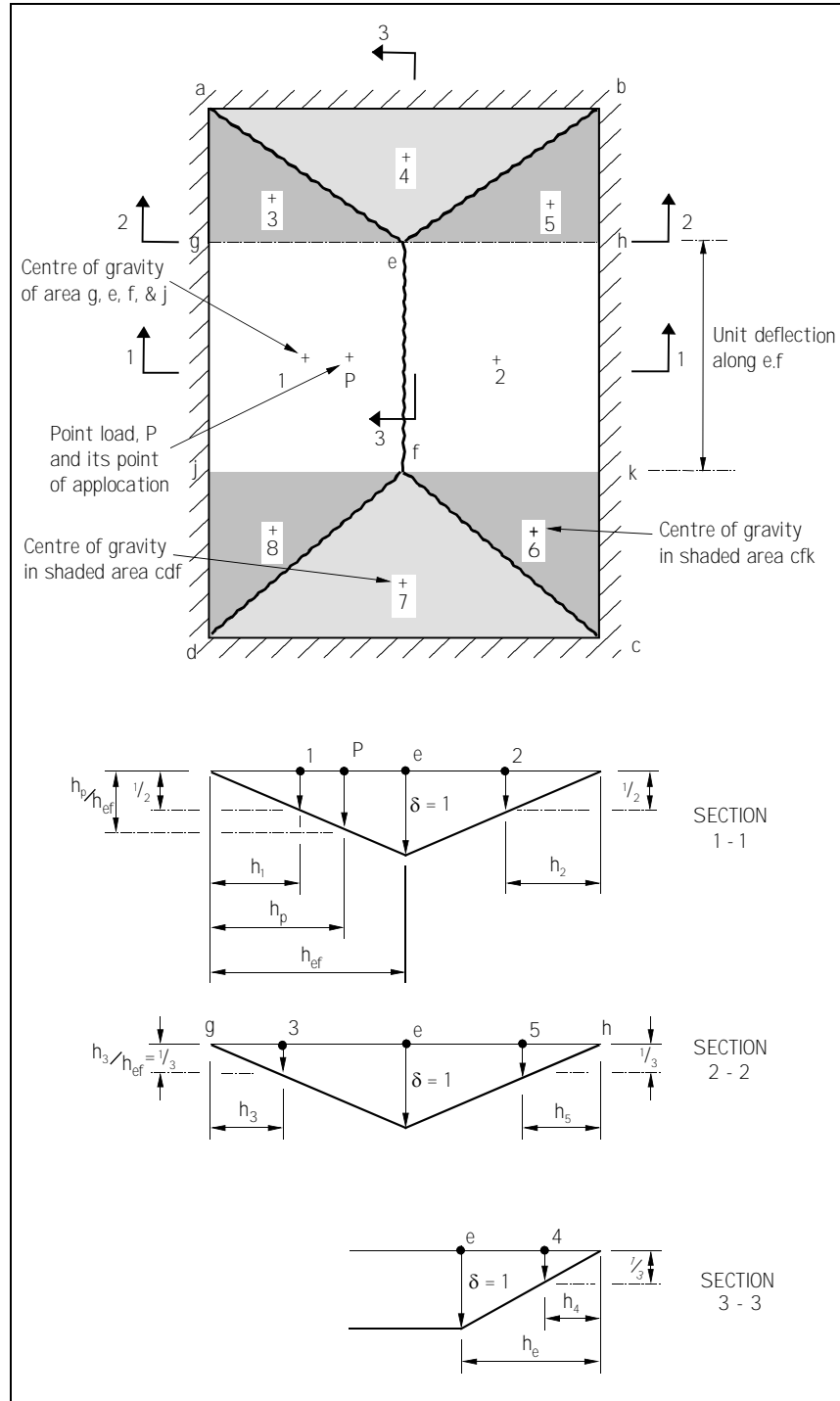
When applying the Work Method the calculations for the expenditure of external loads and the dissipation of energy within the yield lines are carried out independently. The results are then made equal to each other and from the resulting equation the unknown, be it the ultimate moment 'm' generated in the yield lines or the ultimate failure load 'n' of the slab, evaluated.

### Calculating expenditure of energy of external loads: E

Having chosen a layout of yield lines forming a valid failure pattern, the slab is divided into rigid regions that rotate about their respective axes of rotation along the support lines. If we give the point of maximum deflection a value of unity then the vertical displacement of any point in the regions is thereby defined. The expenditure of external loads is evaluated by taking all external loads on each region, finding the centre of gravity of each resultant load and multiplying it by the distance it travels.

In mathematical terms:  $E = \sum (N \times \delta)$  for all regions

The principles are illustrated in Figure 2.9. Having chosen a valid pattern and layout the points of application of all resultant loads are identified. Points 1-8 are the points of application of the resultant of the uniformly distributed loads in the individual regions bounded by the yield lines. Point 'P' is the point of application of the point load P.



**Figure 2.9** Principles of expenditure of external loads: E

*In the shaded triangular areas the resultant of the udl (i.e. the point of application) lies one third of the distance from the line of support towards the line of maximum deflection, e-f. Similarly the resultant for the unshaded rectangular areas lies half way between the lines of support and line e-f. As the maximum deflection of the slab is given the value of unity the vertical displacement of all the resultant loads at their respective locations can be uniquely defined.*



### Calculating dissipation of energy within the yield lines: D

The dissipation of energy is quantified by projecting all the yield lines around a region onto, and at right angles to, that region's axis of rotation. These projected lengths are multiplied by the moment acting on each length and by the angle of rotation of the region. At the small angles considered, the angle of rotation is equated to the tangent of the angle produced by the deflection of the region. The sense of the rotations is immaterial.

In mathematical terms:  $D = \sum (m \times l \times \theta)$  for all regions

Figure 2.10 (see over) is a graphical presentation of the terms involved in the dissipation of internal energy along the yield lines, (assuming an isotropic layout of reinforcement). In region D, for instance, the projection of the positive (sagging) yield line of value 'm' surrounding that region a-b-e onto its axis of rotation, a-b, has the length a-b, shown as length 'Lx'. Similarly the yield lines d-f-c around region A are projected onto d-c and has the length of 'Lx'.

In region C, the projection of the positive (sagging) yield line of value 'm' surrounding that region b-e-f-c onto its axis of rotation, b-c, has the length b-c, shown as length 'Ly'. This side also has continuous support and a negative (hogging) yield line, of value m', that forms along the support. As this yield line already lies on the axis of rotation, it has a projected length equal to the length of the side b-c, again shown as length 'Ly'. The angle of rotation of region C affecting both these moments is shown in section 1-1. It will be seen that, by definition, the angle of rotation  $\phi_c$ , equals  $1/h_c$ . A similar procedure is applied to the other regions.

The yield lines a-e-f-d around region B would be projected onto a-d. In this case as it is a simple support no negative moment would develop at the support.

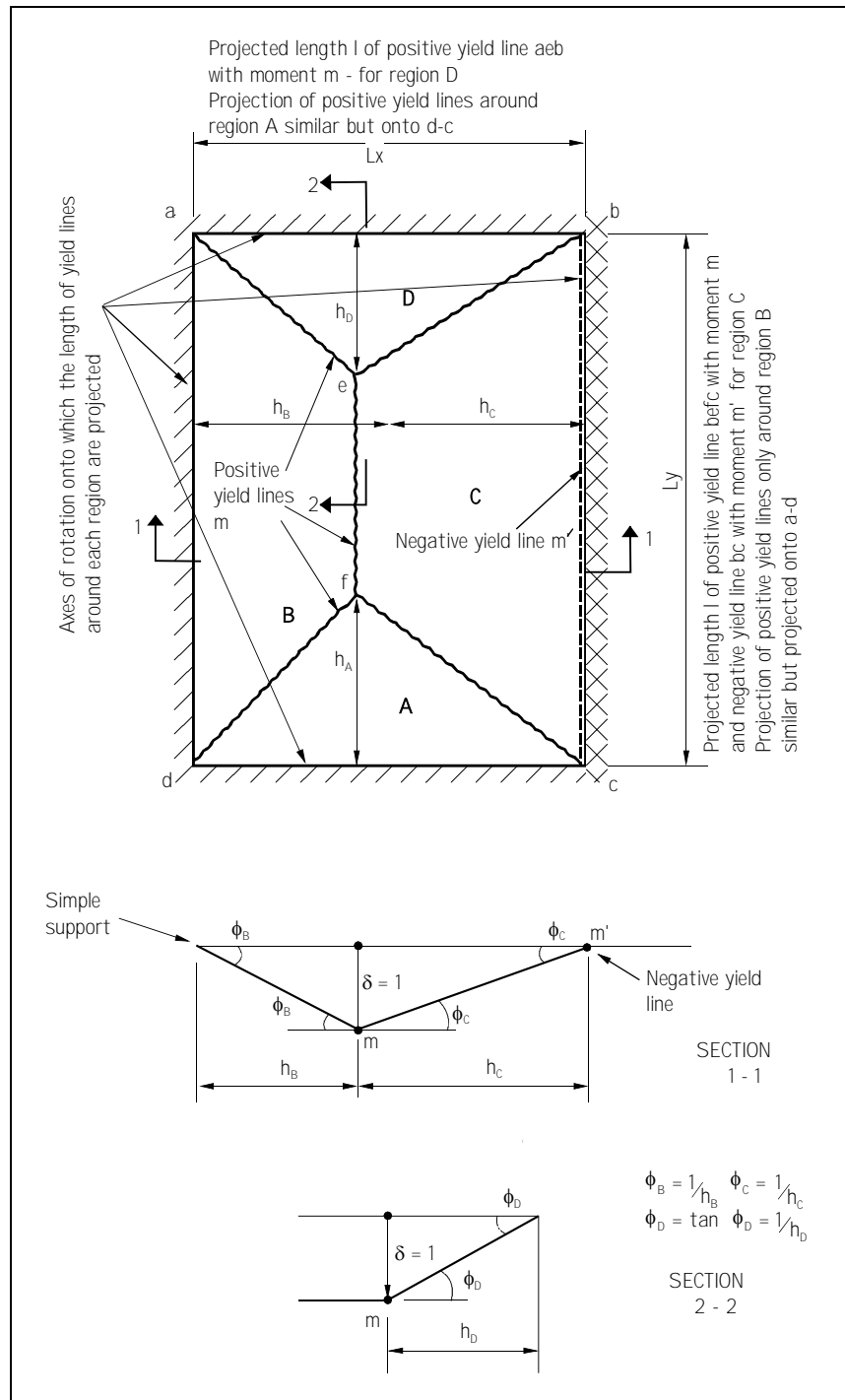


Figure 2.10 Principles of dissipation of internal energy, D

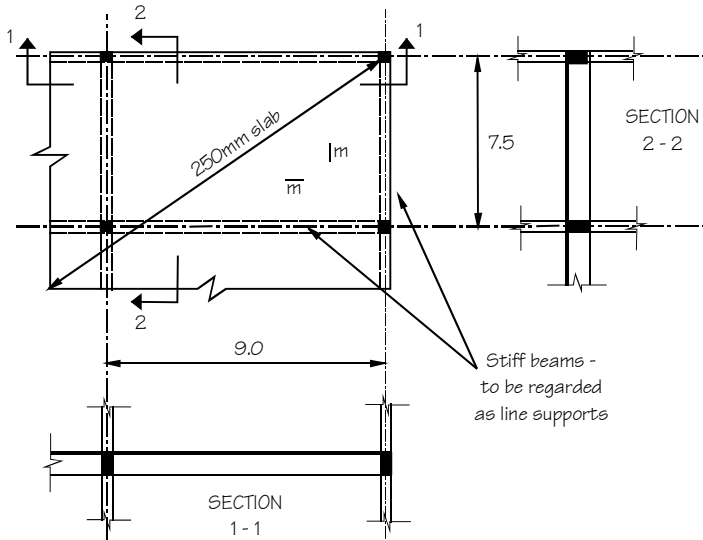
## Example 2A

### Two-way slab using the Work Method (simple yield pattern)

Using the Work Method, analyse and design a 250 mm thick reinforced concrete slab spanning 9.0 x 7.5 m. The slab occupies a corner bay of a floor, which has columns at each corner connected by stiff beams in each direction. The slab can be regarded as being continuous over two adjacent sides and simply supported on the other two. Assume isotropic reinforcement with equal 'm' in each direction. Allow for a total ultimate load of 20 kN/m<sup>2</sup>. Concrete is C40, cover 20 mm T&B.

Determine the effect of an additional ultimate line load of 20 kN/m located at the middle of the shorter span.

Slab layout



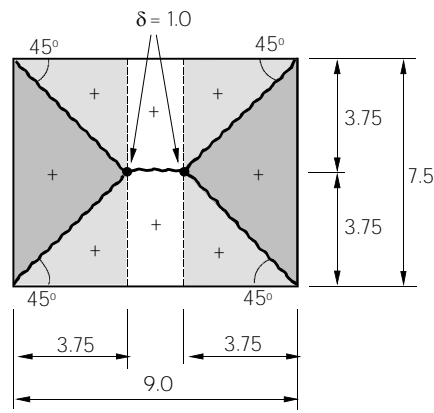
SECTION 1-1

SECTION 2-2

Stiff beams - to be regarded as line supports

Work method applied:

a) First establish the value of  $m$  omitting the line load.  
Let all yield lines bisect the corners at  $45^\circ$

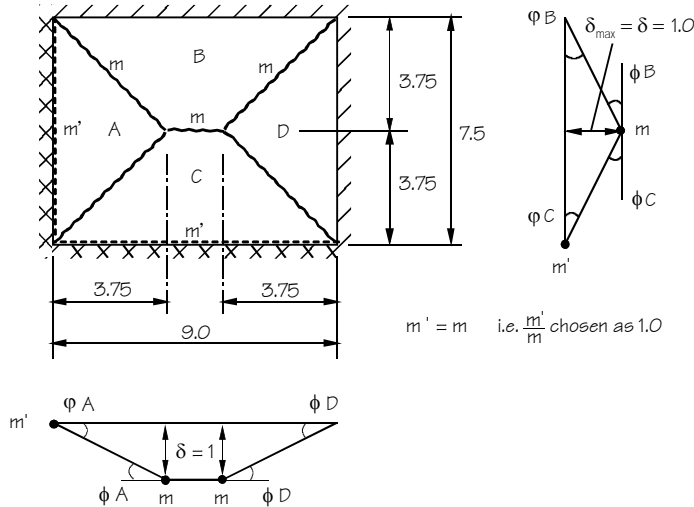


Expenditure of energy by the external loads

$$\begin{aligned}
 E^E &= \sum(N \times \delta) \\
 &= 20 \text{ kN/m}^2 \times 7.5 \times 7.5 \times \frac{1}{3} = 375.0 \\
 &= 20 \text{ kN/m}^2 \times 1.5 \times 7.5 \times \frac{1}{2} = 112.5 \\
 \Sigma &= 487.5
 \end{aligned}$$

[regions A and D and parts of B and C]  
[parts of regions B and C]

$E = 487.5 \text{ kNm/m}$



Dissipation of internal energy in the yield lines

$$D = \sum(m \times l \times \theta):$$

i.e:

$$D = A: \begin{cases} m \times 7.5 \times \frac{1}{3} \times 3.75 = 2m \\ m' \times 7.5 \times \frac{1}{3} \times 3.75 = 2m \end{cases} \text{ as } m' = m$$

$$B: m \times 9.0 \times \frac{1}{3} \times 3.75 = 2.4m$$

$$C: \begin{cases} m \times 9.0 \times \frac{1}{3} \times 3.75 = 2.4m \\ m' \times 9.0 \times \frac{1}{3} \times 3.75 = 2.4m \end{cases} \text{ as } m' = m$$

$$D: m \times 7.5 \times \frac{1}{3} \times 3.75 = 2.0m$$

$$\Sigma = 13.2m$$

$D = 13.2m \text{ kNm}$

<sup>E</sup> In carrying out the calculations for expenditure of external energy, E, the loads for all the triangular regions can be expressed as a single total load, rather than working out each load separately, as they all have the same displacement of  $\frac{1}{3} \delta_{\max}$ . Similarly, rectangular regions have the same displacement of  $\frac{1}{2} \delta_{\max}$ .

From the equality of energies exerted we have:  $D = E$

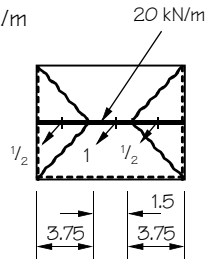
i.e.  $m \times 13.2 = 487.5$

$m = 487.5/13.2 = 36.9 \text{ kNm/m}$

$m' = 36.9 \text{ kNm/m}$

b)

Now we will add the line load of  $20 \text{ kN/m}$  parallel to the longer side with crack pattern of a). The worst case is where the line load is over the yield line (otherwise expended energy would be less) viz:



To 'E' of 487.5 we add:

$$20 \text{ kN/m} \times 7.5 \times \frac{1}{2} = 75$$

$$20 \text{ kN/m} \times 1.5 \times 1 = 30$$

$$\Sigma = 105$$

i.e.  $E = 487.5 + 105 = 592.5$

$E = 592.5$

'D' is the same as before:

$D = 13.2\text{m}$

From  $D = E$  we get:  $13.2\text{m} = 592.5$

$m = 592.5 / 13.2 = 44.89 \text{ kNm/m} = m'$

Thus the partition line increases  $m$  from  $36.9$  to  $44.89 \text{ kNm/m}^F$

<sup>F</sup> Had the line load been a fixed partition in the span, then actual positional dimensions could have been used, but with little increase in accuracy

### Example 2B

#### Two-way slab using the Work Method (precise yield pattern)

Re-analyse Example 2A using the dimensioned layout of yield lines determined in Example 3D (by using formulae for this same slab). As before, allow for an ultimate uniformly distributed load of  $20 \text{ kN/m}^2$

Slab layout - dimensions of the yield lines determined in Example 3D:

$m' = m$   
 $E = 20 \text{ kN/m}^2 \times 8.16 \times 7.5 \times \frac{1}{3} = 408$   
 $20 \text{ kN/m}^2 \times 0.84 \times 7.5 \times \frac{1}{2} = 63$   
 $\Sigma = 471$   
 $E = 471$   
 $D = A: \begin{cases} m \times 7.5 \times \frac{1}{4.78} = 1.57 \text{ m} \\ m' \times 7.5 \times \frac{1}{4.78} = 1.57 \text{ m} \end{cases} \quad \text{as } m' = m$   
 $B: m \times 9.0 \times \frac{1}{3.11} = 2.89 \text{ m}$   
 $C: \begin{cases} m \times 9.0 \times \frac{1}{4.39} = 2.05 \text{ m} \\ m' \times 9.0 \times \frac{1}{4.39} = 2.05 \text{ m} \end{cases} \quad \text{as } m' = m$   
 $D: m \times 7.5 \times \frac{1}{3.38} = 2.22 \text{ m}$   
 $\Sigma = 12.35 \text{ m}$   
 $D = \underline{12.35 \text{ m}}$   
 From  $D = E$  we get  $12.35 \text{ m} = 471$   
 $m = 471/12.35 = 38.14 \text{ kNm/m}$   
 $m' = \underline{38.14}$

## 2.2.12 A question of accuracy

The same 9.0 x 7.5 m slab has been analysed in two different ways. It is also analysed in Example 3D. The results of the three analyses are as follows:

**Table 2.1** Comparison of yield line methods

Example	Value of $m$ (kNm/m)		Comments
	udl	udl + line load	
Example 2A	36.93	44.89	Work Method – simple layout of yield lines
Example 2B	38.14		Work Method - exact
Example 3D	38.18	46.26	Formulae - exact

In Example 2A, a layout was chosen which had all the yield lines bisecting the corners at 45 degrees. This made the calculation of Dissipation of Energy very quick and easy as all the regions had the same angle of rotation.

However, there is a marked difference between this layout and the theoretically correct one as determined by Example 3D and explored in Example 2B. Yet the calculated moment of 36.93 kNm/m in Example 2A compared to 38.14 kNm/m in Example 2B is only 3% too low. Likewise, when the line load was added in Example 2A the resulting moment of 44.89 kNm/m compares to 46.26 kNm/m calculated in example 3D. This shows the same 3% difference. Example 2B was undertaken to show that the Work Method, when applied to patterns known to be correct, does produce the same answers (apart from rounding errors!).

**These results clearly demonstrate that very good results can be achieved with simple approximate layouts.**

In practice, it is common to accept that there will be some inaccuracy when using simple layouts but compensate by adding 10% to the moment or reinforcement to that required by design - as provided for by applying the '10% rule' (see 1.2.12).

These examples assumed the same reinforcement and cover top, over supports, and bottom in the span, i.e.  $m = m'$ . Providing the ratio of  $m$  to  $m'$  is within reasonable limits (say 0.5 to 2.0), the designer may choose to use ratios other than 1.0 for span to support moments.

These examples assumed isotropic bottom reinforcement, i.e. that  $m_x = m_y$ : in other words, equal ' $m$ ' in each direction. The next section deals with slabs where the designer chooses to use different amounts of reinforcement in the two directions, i.e. orthotropic slabs.

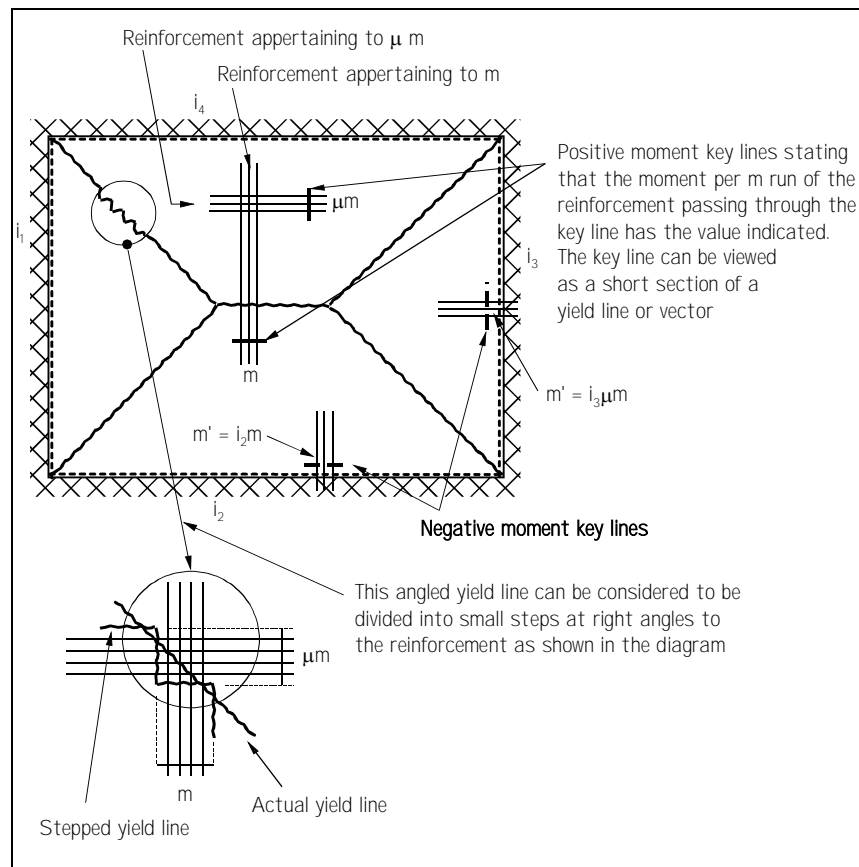
## 2.3 Orthotropic slabs

### 2.3.1 Introduction

So far we have been dealing solely with slabs that have had the same amount of bottom reinforcement in each direction at right angles to each other. These isotropic slabs are analysed to give the same ultimate positive moments,  $m$ , in each direction. In this respect the slight variation in their resistance moments that would result from the differing effective depths is ignored.

In the case of rectangular slabs where there is a marked difference between the two spans it is obviously more economical to span in the short direction and therefore put more reinforcement in the short direction. It is usual therefore to allow a greater moment,  $m$ , to develop in the shorter span and a lesser moment,  $\mu m$  in the longer span. This then becomes an orthotropic slab.  $\mu$  is the ratio of the moment capacity in the weaker direction to the moment capacity in the stronger direction. It has a value  $<1$ . The actual value depends on the designer's choice for the ratio of the two moments or, more usually, the ratio of the reinforcement areas in the two directions. At the relatively low levels of moments generally encountered in slabs, the premise that moment capacity is directly proportional to area of reinforcement is valid.

Conventionally, key lines are added to diagrams of orthotropic slabs to indicate the relative capacity of the slab in each direction. Key lines may be regarded as short sections of yield line and are therefore perpendicular to the relevant reinforcement.



**Figure 2.11** Slab with orthotropic reinforcement

Orthotropic slabs can be analysed from first principles using the Work method following the same procedures as outlined in Section 3. However, when carrying out the dissipation



of internal energy along the yield lines, we work with the value  $\mu m \times l \times \theta$  for the internal energy dissipated by yield lines rotating about the relevant axis of rotation. In other words,  $\mu m$  replaces  $m$  for the reinforcement in this direction.

Analysing orthotropically reinforced slabs from first principles can become somewhat tedious and difficult. This is especially so for slabs with complex shapes and support configurations or slabs subjected to dominant point loads or line loads. These types of slabs are much more easy to analyse when they are assumed to be isotropically reinforced.

### 2.3.2 Affine Transformations

The process that allows an orthotropic slab to be analysed as an equivalent isotropic slab is called **Affine Transformation**. When solved, an Affine Transformation produces a moment,  $m$ , of the same value as that of the original orthotropic slab.

The technique is also very useful for solving slabs where formulae exist only for the isotropic case.

### 2.3.3 The rules of Affine Transformation

The rules for converting an orthotropic slab to an equivalent isotropic slab for the purpose of determining the ultimate moment,  $m$ , are as follows:

1	All distances in the direction of the $\mu m$ reinforcement (usually the long direction) in the converted Affine slab are obtained by dividing corresponding lengths in the original orthotropic slab by $\sqrt{\mu}$
2	Total loads in the converted Affine slab are obtained by dividing the <i>total</i> loads in the <i>original</i> corresponding orthotropic slab by $\sqrt{\mu}$

These rules are shown graphically in Table 2.2.

We use this transformation in order to compute the value of  $m$  in the transformed equivalent isotropic slab. The value of  $m$  derived for the isotropic slab applies also to the original orthotropic slab. To get the value of  $\mu m$  in the orthotropic slab, we multiply the value of  $m$  by  $\mu$ .

Any distances in the direction of the  $\mu m$  reinforcement taken from the isotropic slab will have to be multiplied by  $\sqrt{\mu}$  to arrive at the correct distance in the original orthotropic slab.

For design purposes, it is recommended that the '10% rule' is applied in the normal way to allow for inaccuracies and corner levers.

**Table 2.2** Rules for transforming orthotropic slabs to isotropic slabs for the purpose of analysis

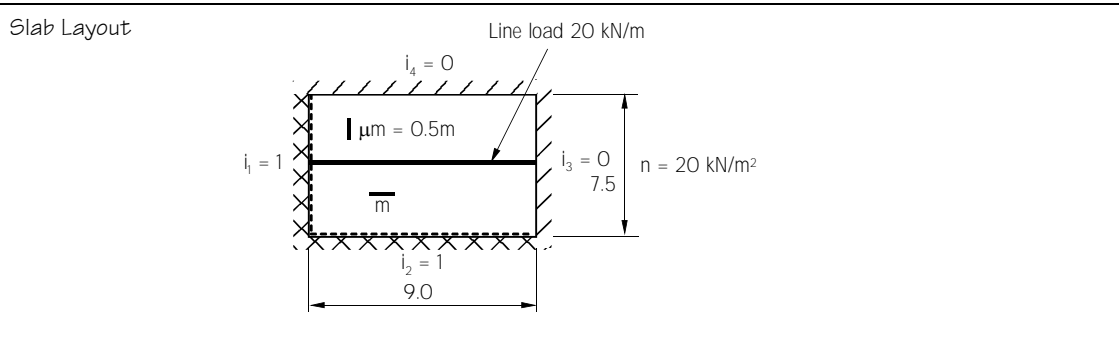
Case	Orthotropic slab	Equivalent isotropic slab, i.e. <u>converted</u> affine slab
	with $\mu < 1$	
1)	udl's and point loads $n \text{ kN/m}^2 + P \text{ kN}$	
2)	Line load $P_b \text{ kN/m}$	
3)	Line load $P_a \text{ kN/m}$	
4)	Skew line load $p_s \text{ kN/m}$	

NB:  $n$  and  $P_b$  are not divided by  $\sqrt{\mu}$  - consider rule 2 in relation to the dimensions of the converted Affine slab.

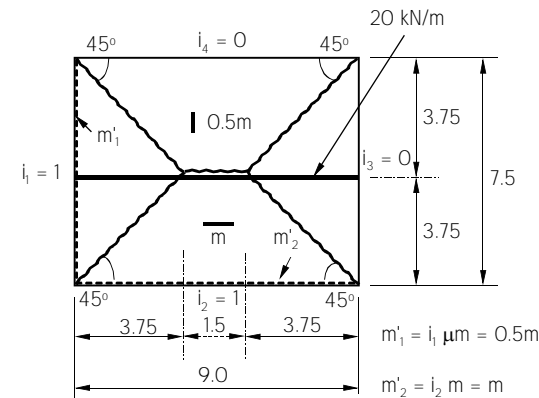
## Example 2C

### Two-way slab using the Work Method (orthotropic slab)

Analyse the slab of example 2A (2B and 3D) again from first principles firstly using the Work Method. Use a ratio of 0.5 for the longitudinal to transverse steel and use a simplified yield line pattern with 45° angles for the inclined yield lines. Secondly, analyse the same slab (again with  $\mu = 0.5$ ) using an Affine Transformation. In both cases, allow for an ultimate uniformly distributed load  $20 \text{ kN/m}^2$  and an additional ultimate line load of  $20 \text{ kN/m}$  located at the middle of the shorter span.



#### Part 1 Analysis using the Work method



$$\begin{aligned}
 E &= 20 \text{ kN/m}^2 \times 7.5 \times 7.5 \times \frac{1}{3} = 375.0 && \text{triangular areas} \\
 &20 \text{ kN/m}^2 \times 1.5 \times 7.5 \times \frac{1}{2} = 112.5 && \text{rectangular areas} \\
 &20 \text{ kN/m} \times 7.5 \times \frac{1}{2} = 75.0 && \text{partition: ends} \\
 &20 \text{ kN/m} \times 1.5 \times 1 = 30.0 && \text{partition: centre} \\
 \Sigma &= 592.5
 \end{aligned}$$

$$\begin{aligned}
 D &= 3 \times 0.5 \text{ m} \times 7.5 \times \frac{1}{3.75} = 3.0 \text{ m} && \text{as } m'_1 = 0.5 \text{ m, and 3 yield lines}^G \\
 &3 \times 9.0 \times \frac{1}{3.75} = 7.2 \text{ m} && \text{as } m'_2 = m \\
 \Sigma &= 10.2
 \end{aligned}$$

From  $D = E$  we get:  $10.2 \text{ m} = 592.5$

$$\underline{592.5 / 10.2 = 58.09 \text{ kNm/m}}$$

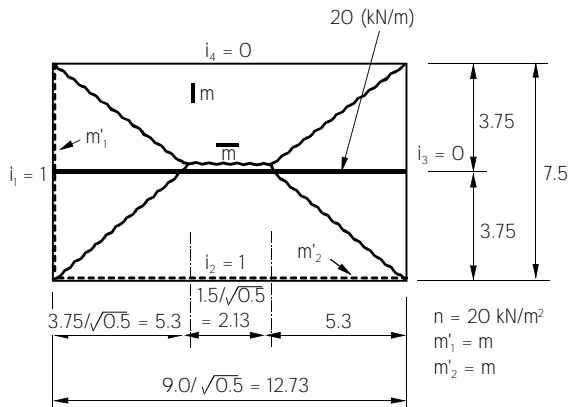
$$\mu m = 0.5 \times 58.09 = 29.045$$

$$i_1 \mu m = m'_1 = 0.5 \times 58.09 = 29.045$$

$$i_2 m = m'_2 = 58.09$$

<sup>G</sup> One negative yield line at the continuous support and two positive yield lines in the span.

Part 2 Analysis using affine transformation



N.B Following the affine transformation, moment =  $m$  in both directions

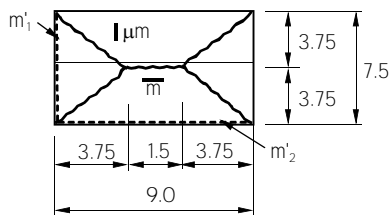
$E = 20 \text{ kN/m}^2 \times 10.6 \times 7.5 \times \frac{1}{3} = 530.0$	triangular areas
$20 \text{ kN/m}^2 \times 2.13 \times 7.5 \times \frac{1}{2} = 159.8$	rectangular areas
$20 \text{ kN/m} \times 10.6 \times \frac{1}{2} = 106.0$	partition: ends
$20 \text{ kN/m} \times 2.13 \times 1 = 42.6$	partition: centre
$\Sigma = 838.4$	

$D = 3 \times m \times 7.5 \times \frac{1}{5.3} = 4.25m$
$3 \times m \times 12.73 \times \frac{1}{3.75} = 10.28m$
$\Sigma = 14.43$

From  $D = E$  we get:  $14.43m = 838.4$

$m = 838.4 / 14.43 = 58.09 \text{ kNm/m}$

Converting back



NB  $12.73 \times \sqrt{0.5} = 9.0$

$m = 58.09 \text{ kNm}$

$\mu m = 0.5 \times 58.09 = 29.05 \text{ [kNm/m]}$

$m'1 = i1 \mu m = 0.5 \times 58.09 = 29.05 \text{ kNm/m} \quad \text{as } i1 = 1$

$m'2 = i2 m = 58.09 \text{ kNm/m} \quad \text{as } i2 = 1$

**Comments on calculations**

As can be seen from this example the Work Method applied to the original slab gives the same answers as the one applied to the transformed slab. More details are given in reference 14. As mentioned earlier, there will be cases where the transformation technique will be the only method available to provide a workable solution.

For design purposes, it would be usual to apply the '10% rule' to allow for the effects of corner levers, and yield line being an upper bound solution.

## 3.0 Standard formulae for slabs

This Chapter deals with standard formulae that may be used for yield line solutions for common types of slab. It may be regarded as a quick reference for common solutions. The formulae cover varying support and loading arrangements and have been taken from the solutions given by K. W. Johansen [5, 6] in his works.

So far in this publication it has generally been assumed that support moments equal span moments. However, formulae give the designer a wide choice for the size of support moments. This is done by using  $\alpha$  factors which are chosen to reflect the kind of restraint offered by the support expressed in terms of the ratio of the support moment to mid-span moments. The values commonly attributed to these  $\alpha$  factors or fixity ratios are 0 for a simple support, giving no resistance to rotation, up to anything between 1 and 2 usually dependant on the rotational resistance offered by the continuing slab in the adjoining bay. The values of  $\alpha$  should to some extent reflect the elastic continuity in order to limit problems in the serviceability state.

Design codes of practice limit the amount of redistribution of moments that may take place in the design of a section. Clause 3.2.2.1 of BS 8110 requires that the resistance moment at any section should be at least 70% of the moment at that section obtained from an elastic analysis covering all load combinations. (Similar and other requirements apply in prEN 1992-1-1 [3].) Whilst it may be thought imperative to check the moments determined from a yield line analysis against those for an elastic analysis, there is rarely a problem and unless extreme values of  $\alpha$  are used, such calculations are unwarranted in the majority of cases (see Example 3C).

The failure patterns produced by the yield lines in slabs depend on the nature of both the loading and support conditions. They may be very simple, as in the case of a simply supported one-way spanning slab, or may be more complex when the slab has a combination of loads on an irregular support arrangement. The intention in this publication is to provide formulae for the more common one-way and two-way slabs on regular supports. The more complicated arrangements are dealt with in standard texts [2, 6].

One of the great benefits of yield line analysis is that, as opposed to elastic analysis, the designer may choose how moments are distributed between individual spans, bays or sections. This is a distinct advantage, for instance, in refurbishment where the resistance moment of an existing slab is predetermined.

The formulae are not subject to the restrictions of BS 8110 cl 3.5.2.3 with respect to loads, spans, etc. The designer should none the less be wary of the need to check curtailment and possible hogging in spans.

## 3.1 One-way spanning slabs

### 3.1.1 General

The general form of the formulae for one-way spanning slabs supporting uniformly distributed loads is as follows [2, 6].

$$m = \frac{nL^2}{2(\sqrt{1+i_1} + \sqrt{1+i_2})^2}$$

where

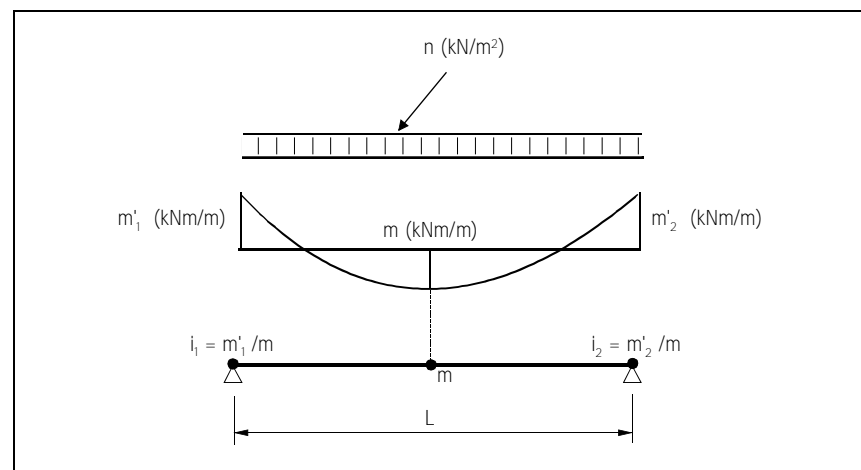
$m$  ultimate moment along the yield line [kNm/m]

$n$  ultimate load [kN/m<sup>2</sup>]

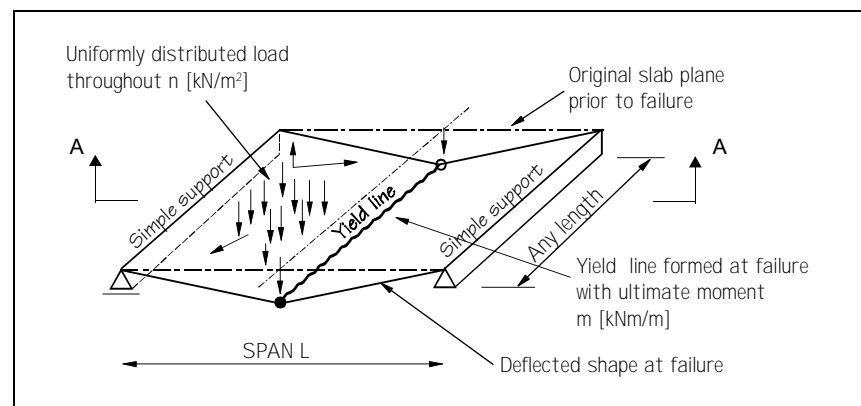
$L$  span [m]

$i_1, i_2$  ratios of support to mid-span moments, the values of which are chosen by the designer:  $i_1 = m'_1/m$ ,  $i_2 = m'_2/m$

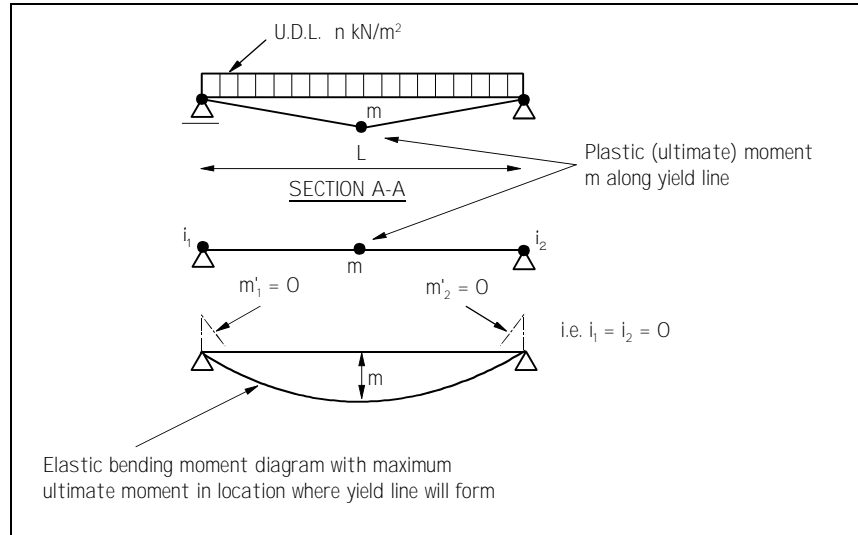
A proof is given in the Appendix, but by way of explanation, Figures 3.1 to 3.3 consider a simply supported one-way slab with a uniformly distributed load.



**Figure 3.1** One-way spanning slab



**Figure 3.2** Axonometric view of a simply supported one-way spanning slab



**Figure 3.3** Loading, hinge locations and bending moment diagram for simply supported slab

Using the general formula and  $i_1 = i_2 = 0$ : ( $i_1 = m'_1/m = 0$  and  $i_2 = m'_2/m = 0$ )

$$m = \frac{nL^2}{2(\sqrt{1+i_1} + \sqrt{1+i_2})^2} = \frac{nL^2}{2(\sqrt{1+0} + \sqrt{1+0})^2}$$

$$m = \frac{nL^2}{2(2)^2} = \frac{nL^2}{8} \text{ kNm/m}$$

So the plastic ultimate moment along the yield line is  $nL^2/8$ , which we know is correct!

### 3.1.2. Design formulae

The formulae to establish the value of the maximum midspan moment 'm' for any span within a continuous slab are given in Table 3.1. Cases 2, 3 and 4 are variations on the base formula for case 1.

The formulae in Table 3.1 enable the designer to choose a set of values for the negative and positive ultimate moments in each bay of a continuous slab for the maximum design ultimate load 'n'. This is carried out on the assumption that all spans are loaded with the ultimate load 'n'. This is also the recommendation of clause 3.5.2.3 of BS 8110, but is subject to the restrictions that

- $p_k / g_k < 1.25$ ,
- $p_k$  (excluding partitions)  $< 5 \text{ kN/m}^2$  and
- the bay areas exceed  $30 \text{ m}^2$ .

With Yield Line Theory these restrictions do not apply as there are ways of investigating the effect that pattern loading has on the design ultimate moments chosen for any span. Tables 3.3 and 3.4 describe this procedure.

Please note that in Table 3.1 opposite:

- In cases 1 & 2 the ratio of support moments to midspan moments have been fixed
- In cases 3 & 4 the magnitude of the support moments have been fixed
- In cases 5 & 6 the ratio of one support moment to midspan moment and the magnitude of the other support moment have been fixed.



**Table 3.1** Formulae for one-way slabs - to establish midspan yield line moment 'm' in a span of a continuous slab

Case	Diagram	Formula	
1		$m = \frac{nL^2}{2(\sqrt{1+i_1} + \sqrt{1+i_2})^2}$	
2		$m = \frac{nL^2}{2(1 + \sqrt{1+i_2})^2}$	
3		$m = \frac{nL^2 - 4\left(m'_1 + m'_2 - \frac{(m'_1 - m'_2)^2}{nL^2}\right)}{8}$	
4		$m = \frac{nL^2 - 4\left(m'_2 - \frac{(m'_2)^2}{nL^2}\right)}{8}$	
5		$m = \frac{nL^2 - 4\left(m'_2 - \frac{(m'_2)^2}{nL^2}\right)}{4(1 + 0.5i_1 + \sqrt{1+i_1})}$	<p>Approx. These formulae can err 5-10% on the high side, especially when there is a large difference between the end moments</p>
6		$m = \frac{nL^2 - 4\left(m'_1 - \frac{(m'_1)^2}{nL^2}\right)}{4(1 + 0.5i_2 + \sqrt{1+i_2})}$	

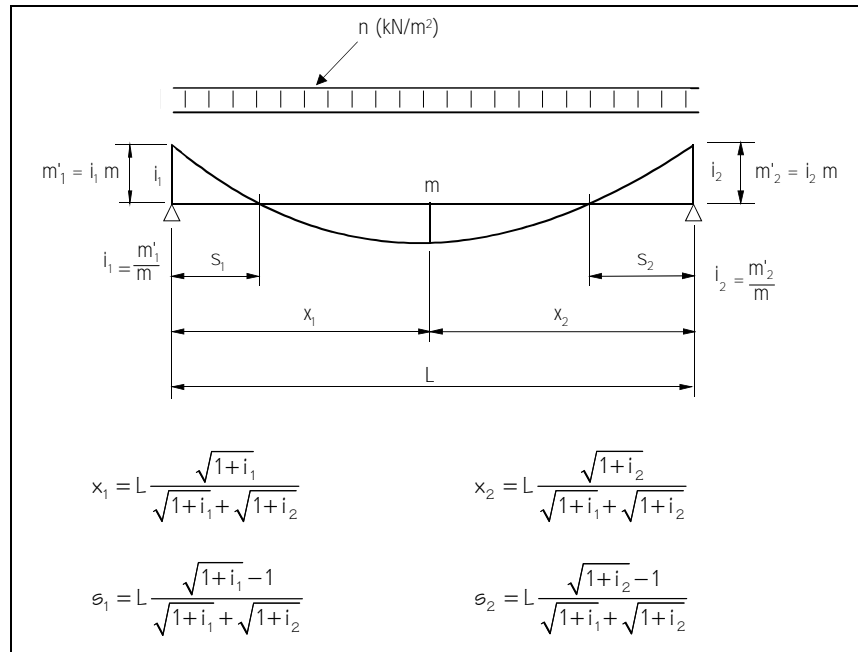
Where

- m is the ultimate moment along the yield line [kNm/m]
- n is the ultimate load per unit area [kN/m<sup>2</sup>]
- L is the span, either centreline-to-centreline, or with integral supports, clear span [m]
- $i_1, i_2$  are the ratios of support to midspan moments, whose values are chosen by the designer
- $m'_1, m'_2$  are the support moments - the values of which are chosen by the designer. The values could be established from analysis carried out on an adjacent bay [kNm/m]

### 3.1.3 Location of maximum midspan moments and points of contraflexure

Table 3.2 presents expressions for the location of maximum midspan moments and points of contraflexure. The parameters  $s_1$  and  $s_2$ , the location of the points of contraflexure, are needed when checking the extent of top steel in accordance with BS 8110 clause 3.2.2.1 condition 3 which states: "Resistance moment at any section should be at least 70% of moment at that section obtained from an elastic maximum moments diagram covering all appropriate combinations of design ultimate load."

**Table 3.2** Location of maximum midspan moments and points of contraflexure



Where

- $x_1, x_2$  are the distances to maximum span moment [m]
- $s_1, s_2$  are distances to points of contraflexure, i.e. points of zero moment [m]
- $L$  span [m]
- $i_1, i_2$  are ratios of support to midspan moments
- $m$  is the maximum midspan moment [kNm/m]
- $m'_1, m'_2$  are the support moments [kNm/m]

### 3.1.4 Pattern loading: modes of failure and curtailment of reinforcement

It is important to check how far to project the support steel into lightly loaded bays to ensure that the ultimate design moments at the supports can develop. Tables 3.3 and 3.4 depict the different modes of failure that could occur in continuous slabs when adjacent bays are subject to pattern loading.

In most cases, extending support steel 0.25L into the adjoining span will usually suffice. However, if the designer has any doubt, Tables 3.3 and 3.4 may be used to check curtailment.

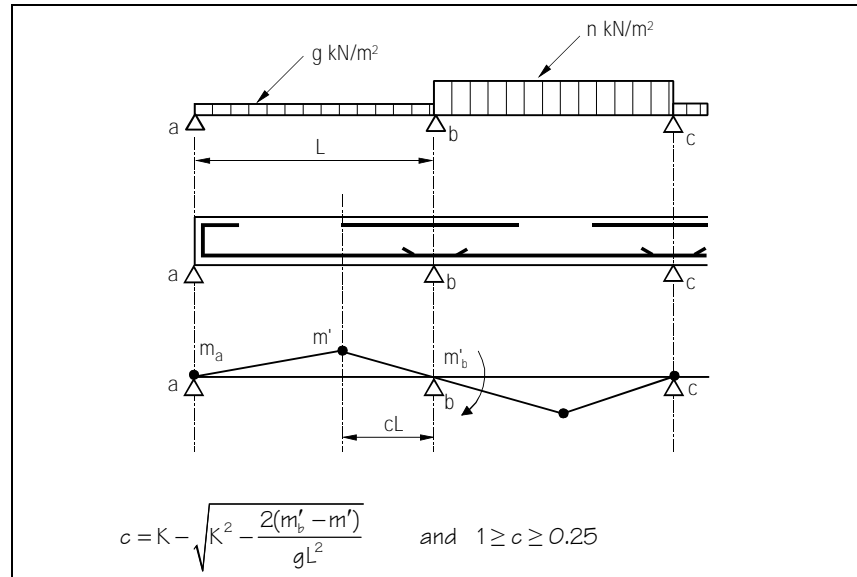
If the curtailed length of top steel is less than the computed length 'cL' then the slab in this bay will fail by cracking at the top, just at the ends of the top reinforcement and it will not be possible for the yielding of the support steel, as assumed in the original design, to take place. If the curtailed length of top steel is equal or greater than the computed length 'cL' then the slab full support moment can develop.

The formulae below are based on the premise that the lightly loaded bay will fail in hogging only if the negative work expended (to bring this failure pattern about) is less than that required to activate the full plastic moment at the support.

### End spans

Table 3.3 gives the formulae for determining the coefficient for the distance from the penultimate support at which 100% of support steel may be terminated in the end bay.

**Table 3.3** End span curtailment formulae: end span lightly loaded



Where

$c$  is the coefficient for the distance from support at which 100% of support steel may be terminated.

$K$  is the a factor having the value:

$$K = \frac{m'_b + m_a}{gL^2} + 0.5 \quad \text{but} \quad K \geq \sqrt{\frac{2(m'_b - m')}{gL^2}} \quad \text{where}$$

$n$  is the total ultimate load,  $1.4g_k + 1.6p_k$  [kN/m<sup>2</sup>]

$g$  is the characteristic dead load  $1.0g_k$  [kN/m<sup>2</sup>]

$m_a$  is the moment of resistance at support a (this is a sagging moment) [kNm/m]

$m'$  is the moment capacity of slab in hogging at section where support steel is terminated [kNm/m]

$m'_b$  is the ultimate support moment at b as previously determined by the designer for the load case of design load 'n' on all spans [kNm/m]

$L$  is the span [m]

The minimum curtailment length is  $cL$  [m].

If the coefficient  $c = 1.0$  then top support steel must be continuous throughout the span. Should  $c > 1.0$  then one or more of the following changes have to be made:

Reduce the design moment  $m'_b$

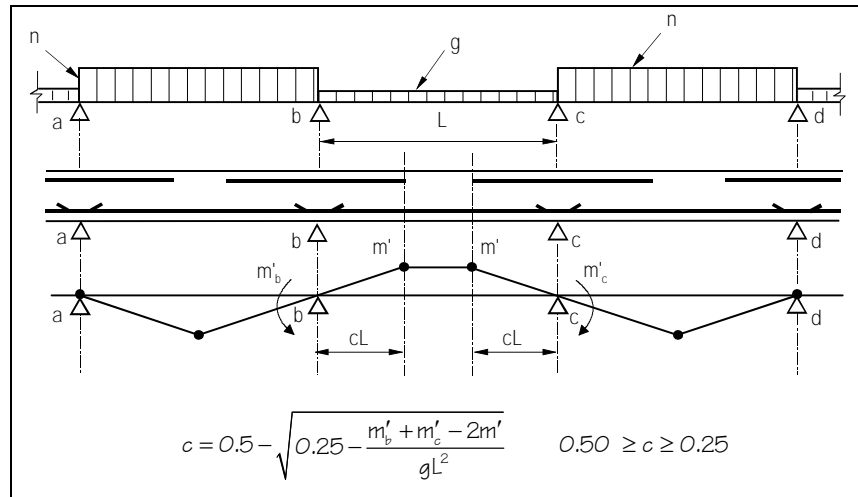
This would entail re-analysing span b-c for the case of design load 'n' on all spans with the new reduced value of  $m'_b$

Increase the design value of $m'$	This would entail lapping a certain quantity of top steel onto the curtailed support steel or making use of the tensile resistance of plain concrete.
Increase the design value of $m_a$	Only possible if support 'a' is not a simple support.

**Internal spans**

Table 3.4 gives the formulae for determining the coefficient for the distance from internal supports at which 100% of support steel may be terminated in internal bays.

**Table 3.4** Internal span curtailment formulae: internal span lightly loaded



Where

- $c$  is the coefficient for the distance from support at which 100% of support steel may be terminated.
- $m'$  is the moment capacity of slab in hogging at section where support steel is terminated [kNm/m].
- NB by statics  $m' \geq \frac{m'_b + m'_c}{2} - \frac{gL^2}{8}$
- $m'_b, m'_c$  ultimate support moments at b and c as previously determined by the designer for the load case of design load 'n' on all spans [kNm/m]
- $n$  is the total ultimate load,  $1.4g_k + 1.6 p_k$  [kN/m<sup>2</sup>]
- $g$  is the characteristic dead load  $1.0g_k$  [kN/m<sup>2</sup>]
- $L$  is the span [m]

The minimum curtailment length is  $cL$  [m]. If the coefficient  $c \geq 0.5$ , then top support steel must be continuous throughout the span.

**3.1.5 Maximum redistribution of moments**

In order to limit problems in the serviceability state, codes limit the amount of moment redistribution that can take place. As stated above, clause 3.2.2.1 of BS 8110 requires that the resistance moment at any section should be at least 70% of the moment at that section obtained from an elastic analysis covering all load combinations. (Similar and other requirements apply in prEN 1992-1-1 [3].) While this is not strictly necessary to comply with this requirement when using Yield Line Design, it is advisable to keep within the spirit

of the codes by checking those moments determined from a Yield Line Analysis against those for an elastic analysis.

Table 3.5 gives values of elastic moment coefficients that may be used to check the 70% level in such circumstances. These coefficients are for continuous slabs having approximately equal spans and carrying uniformly distributed loads, all spans loaded, prior to any redistribution, and conforming to BS 8110 Cl 3.5.2.3. (Please note that Table 3.12 of BS 8110: Part 1 cannot be used for this purpose as the coefficients listed include the effect of moment redistribution.)

**Table 3.5** Elastic moment coefficients for one-way spanning slabs - of approximately equal spans prior to any moment redistribution, all spans loaded

No. of spans	K
2	
3	
4	
5	
>5	End and penultimate span and support moments as for 5 spans, centre spans and supports can be taken to have 'K' values of 0.042 and 0.083 respectively.
Elastic moments: $m_e$ or $m'_e = K \times F \times L$ [kNm/m]	

Where

$m_e$  is the elastic moment at midspan [kNm/m]

$m'_e$  is the elastic moment at support [kNm/m]

K is the coefficient for midspan or support moments in one-way spanning slabs prior to redistribution

F is the total ultimate load ( $1.4G_k + 1.6P_k$ ) = nL [kN]

L is the span [m]

n is the total ultimate load,  $1.4g_k + 1.6p_k$  [kN/m<sup>2</sup>]

**Note:** The above coefficients are restricted to the same conditions of use as for BS 8110 Clause 3.5.2.3, which allows the single load case of all-spans-loaded to be used in design provided:

- In a one-way spanning slab, the area of each bay exceeds 30 m<sup>2</sup>
- $p_k \leq 1.25 g_k$
- $p_k \leq 5.0 \text{ kN/m}^2$

### **3.1.6 Design method**

When designing a continuous multi-bay slab, it is usual to proceed bay-by-bay, apportioning moments to the critical sections at supports and in the span where yield lines will ultimately be formed. Yield lines will develop roughly in the same locations as the maximum elastic moments i.e. at supports and midspan. The support moments are usually chosen to be a preferred ratio of support to midspan moment and that does not depart too much from the expected elastic distribution of moments. Often a support moment will have been already determined in the solution to a previous span and so the designer need only choose a ratio for the other support moment. If, however, both support moments have already been established then the remaining span moment is uniquely defined. To this end Table 3.1 is extremely useful as it deals with any of these situations. The design method is illustrated in the following examples:

## Example 3A

### One-way slab using formulae (continuous slab)

Analyse and design a continuous r.c. slab 250 thick, over four 7.5 m spans.

Allow  $1 \text{ kN/m}^2$  for additional dead load,  $1 \text{ kN/m}^2$  for movable partitions and  $2.5 \text{ kN/m}^2$  for imposed load. Concrete is C40, cover 20 mm T&B

#### Analysis and design.

Design procedure	
Parameters	Slab depth $h = 250 \text{ mm}$ Concrete C40 Cover 20 mm T&B
Loading	Dead load 250 slab $0.25 \times 24 = 6.0 \text{ kN/m}^2$ Additional dead load $= 1.0 \text{ kN/m}^2$ $g_k = 7.0 \text{ kN/m}^2$ Live load Superimposed load $= 2.5 \text{ kN/m}^2$ Partitions $= 1.0 \text{ kN/m}^2$ $g_k = 3.5 \text{ kN/m}^2$ Total ultimate load $n = 1.4 \times 7.0 + 1.6 \times 3.5 = 15.4 \text{ kN/m}^2$
Analysis	
Bay 1	$L_1 = 7.5 \text{ m}$
Span a-b	$n = 15.4 \text{ kN/m}^2$
See Table 3.1 Case 2, where $i_1 = i_a$ $i_2 = i_b$ $m = m_1$	

$$i_a = \frac{m'_a}{m_1} = 0 \text{ as } m'_a = 0$$

$$i_b = \frac{m'_b}{m_1}, \text{ choose } i_b = 1.0^H$$

$$m_1 = \frac{nL_1^2}{2(1 + \sqrt{1 + i_b})^2}$$

$$= \frac{15.4 \times 7.5^2}{2(1 + \sqrt{1 + 1})^2}$$

$$= 74.3 \text{ kNm/m}$$

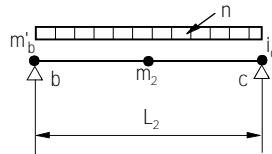
$$m'_b = i_b \times m_1 = 1 \times 74.3 = 74.3 \text{ kNm/m}$$

$$m_1 = 74.3 \text{ kNm/m} : m'_b = 74.3 \text{ kNm/m}$$

Bay 2<sup>I</sup>  
Span b-c

$$L_2 = 7.5 \text{ m}$$

$$n = 15.4 \text{ kN/m}^2$$



See Table 3.1 Case 6, where  $m'_1 = m'_b$ ;  $i_2 = i_c$ ;  $m = m_2$

$$m'_b = 74.3 \text{ kNm/m}$$

$$i_c = \frac{m'_c}{m_2} : \text{choose } i_c = 1.0$$

$$m_2 = \frac{nL_2^2 - 4 \left( m'_b - \frac{m_b'^2}{nL_2^2} \right)}{4(1 + 0.5i_c + \sqrt{1 + i_c})}$$

$$= \frac{15.4 \times 7.5^2 - 4 \left( 74.3 - \frac{74.3^2}{15.4 \times 7.5^2} \right)}{4(1 + 0.5 \times 1.0 + \sqrt{1 + 1.0})}$$

$$= \frac{594.54}{11.66} = 51.0 \text{ kNm/m}$$

$$m'_c = i_c \times m_2 = 1 \times 51.0 = 51.0 \text{ kNm/m}$$

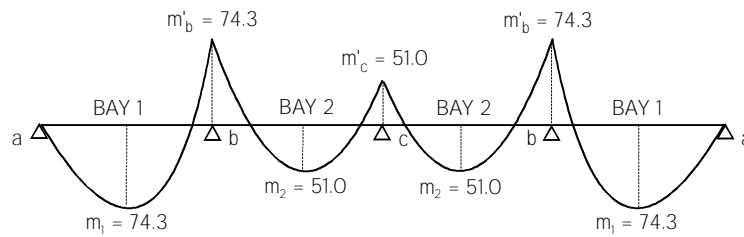
$$m_2 = 51.0 \text{ kNm/m} \text{ and } m'_c = 51.0 \text{ kNm/m}$$

<sup>H</sup> **Analysis: Bay 1.** In an end bay of a continuous slab the ratio of internal support to midspan moment should be between 1 to 2.0, depending on the degree of restraint offered by the adjoining bay. In the majority of cases unity will be the most appropriate choice for the following reasons:

It does not depart too much from an elastic distribution of moments which aids the serviceability requirements, and it usually results in an increase of the midspan moment, which helps to keep down the span/depth ratios with respect to clauses 3.4.6.3 to 7 of BS 8110 by increasing the 'beta factor' in equation 8 (in Table 3.10) of BS 8110.

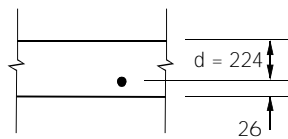


By symmetry resulting moment diagram may be drawn:



### Section Design

#### Bay 1



$$m_1 = m'_b = 74.3 \text{ kNm/m}$$

$$d = 250 - 20 - 12/2 = 224 \text{ mm}$$

$$f_y/\gamma_m = 460/1.05 = 438 \text{ N/mm}^2$$

$$\frac{M_u}{bd^2f_{cu}} = \frac{74.3 \times 10^6}{10^3 \times 224^2 \times 40} = 0.037 \quad \therefore z = 0.95d$$

$$A_{s_{req,d}} = \frac{74.3}{0.95 \times 0.224 \times 0.438} = 797 \text{ mm}^2/\text{m}$$

Provide T12 @ 125 cc (905 mm<sup>2</sup>/m) in span a-b<sup>k</sup> and support b

#### Bay 2

$$m_2 = m'_c = 51.0 \text{ kNm/m}$$

$$A_{s_{req,d}} = \frac{51.0}{0.95 \times 224 \times 0.438} = 547 \text{ mm}^2/\text{m}$$

Provide T12 @ 200 cc (565 mm<sup>2</sup>/m) in span b-c and support c

<sup>i</sup> **Analysis Bay 2.** In the internal bay, as the left-hand support moment has already been fixed, the options for choosing the magnitude of the other support and midspan moments are numerous. A good starting point is to choose the support to midspan ratio for these as unity again and then see if any amendments become necessary.

<sup>j</sup> If precise formulae were used, a more exact answer of 47.69 kNm/m would be derived— some 7% below the approximate answer of 51 kNm/m obtained using Table 3.1 case 6.

<sup>k</sup> **Section design:** In designing the reinforcement in bay 1 the area required is 797 mm<sup>2</sup>/m. However the nearest sensible area of reinforcement is for T12 @ 125 which gives 905 mm<sup>2</sup>/m. This gives an ultimate moment of resistance of 84.35 kNm/m, which represents an increase in capacity of 14 % (i.e. 84.35/74.3) just due to the rounding up of steel area required. This increase will be of most benefit to reduce deflection.

Deflection	The serviceability limit state for deflection will be checked against the span/effective depth ratios as specified in clauses 3.4.6.3 - 3.4.6.6 of BS 8110 <sup>L</sup> .
Bay 1 Span a-b	<p>From BS 8110 cl. 3.4.6.3 Table 3.9 we get basic <math>L/d = 26</math></p> <p>Applying Cl. 3.4.6.5 we get:</p> $f_s = 2f_y A_{s_{reqd}} / (3 A_{s_{prov}} \beta b)$ $= 2 \times 460 \times 797 / (3 \times 905 \times 1.1)$ $= 245 \text{ N/mm}^2$ $M_u / (bd^2) = 74.3 / (1000 \times 0.224^2) = 1.48$ <p>from Table 3.10 of BS8110, modification factor <math>k_1 = 1.36</math>,</p> $L/d \text{ required} = 26 \times 1.36 = 35.4$ $L/d \text{ provided} = \frac{7500}{224} = 33.5$ <p><u>as 33.5 &lt; 35.4 O.K</u></p>
Bay 2 <sup>M</sup> Span b-c	$f_s = 2f_y A_{s_{reqd}} / (3 \times A_{s_{prov}} \beta b)$ $= 2 \times 460 \times 547 / (3 \times 565 \times 1.2)$ $= 247 \text{ N/mm}^2$ $M_u / (bd^2) = 51.0 / (1000 \times 0.224^2) = 1.02$ <p>from Table 3.10 of BS8110, coefficient <math>k_1 = 1.55</math></p> <p>i.e. <math>L/d \text{ required} = 26 \times 1.55 = 40</math></p> $L/d \text{ provided} = \frac{7500}{224} = 33.5$ <p><u>as 33.5 &lt; 40 O.K.</u></p>

<sup>L</sup> **Deflection:** In order to check whether the choice of 1.1 and 1.2 for the code beta factor, for the end and internal bays respectively, were justified we need to establish the elastic ultimate midspan moments prior to redistribution. These factors are given in Table 3.5 and the midspan moments, using the relevant factors from this table, are as follows:

$$m_{e1} = 0.0772 \times 15.4 \times 7.5^2 = 66.87 \text{ [kNm/m]}$$

$$m_{e2} = 0.0364 \times 15.4 \times 7.5^2 = 31.532 \text{ [kNm/m]}$$

In the end bay the correct ratio would be  $74.3/66.87$ , which is 1.11. In the internal bay the correct ratio would be  $51/31.53$ , which is 1.62. It can be seen that the choices were justified. In the internal bay the choice of 1.2 in this instance was very conservative. So we can see that, even without the increase of steel area, which was essential anyway for practical reasons, deflection was not a problem with the adopted ratios for the moments. It must be emphasized that the procedure adopted here of calculating the distribution of elastic moments in order to establish the exact value of the 'beta factor' would not normally be undertaken.

It is the authors' opinion that, for the majority of cases encountered in practice, the method used here for complying with the serviceability limit state is quite adequate. Only when there is serious concern about the effect excessive deflection could have on finishes etc. should there be any necessity for a more rigorous approach.

<sup>M</sup> As before, using Yield Line Theory in the design and analysis of slabs one can, conservatively, use a  $\beta_b$  value of 1.1 for end spans and 1.2 for internal spans. See previous footnote.

## Example 3B

### One-way slab, curtailment of reinforcement

Investigate the effects of pattern loads on curtailment of the top reinforcement design in example 3A.

Pattern loading and curtailment of top reinforcement

Although with respect to Clause 3.5.2.3 of BS 8110: Part 1, we do not need to investigate the effect of pattern loading as the conditions of  $p_k / g_k < 1.25$  and  $p_k < 5 \text{ kN/m}^2$  are satisfied, we will look at alternative bay loading to investigate curtailment lengths and demonstrate the use of Tables 3.3 and 3.4.

a)

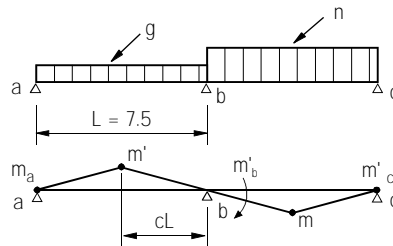
End bay

$$g = 7 \text{ kN/m}^2$$

$$n = 15.4 \text{ kN/m}^2$$

$$m_a = 0$$

$$m' = 0$$



See footnote<sup>N</sup>

$$m'_b = 74.3 \text{ kNm/m} \dots \text{ See Analysis of Bay 1, Span a-b}$$

as Table 3.3

$$K = \frac{m'_b + m_a}{gL^2} + 0.5 = \frac{74.3 + 0}{7 \times 7.5^2} + 0.5 = 0.69$$

But check

$$K \geq \sqrt{\frac{2(m'_b - m')}{gL^2}} = \sqrt{\frac{2(74.3 - 0)}{7 \times 7.5^2}} = 0.614$$

As  $0.69 > 0.614$  O.K.

Curtailment:

$$c = K - \sqrt{K^2 - \frac{2(m'_b - m')}{gL^2}}$$

$$= 0.69 - \sqrt{0.69^2 - \frac{2(74.3 - 0)}{7 \times 7.5^2}} = 0.376$$

<sup>N</sup> **Pattern loading:** In our case we have attributed the value of zero to the plastic hinge forming at the support 'a'. This would be so if the slab were freely supported, on, say, a masonry wall. If the slab is poured monolithically with a reinforced concrete wall or connected to a row of r.c. columns then this plastic hinge would have a value depending on the lesser of the resistance moments of the slab connection and the supporting element. This ultimate moment  $m_a$  is a positive one creating tension in the bottom fibres and is therefore dependant on the amount of bottom steel adequately anchored into the support. In the case of a column support this would be related to the effective moment transfer strip as described in clause 3.7.4.2 of BS 8110: Part 1.

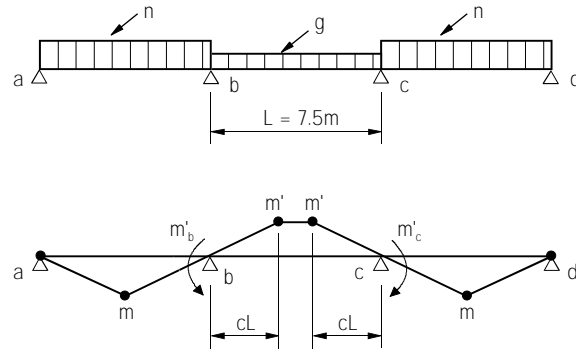
Hogging moment  $m'$  describes the plastic hinge that forms at the section where the top steel terminates and where there is tension in the top fibres. The value of  $m'$  is either related to the area of reinforcement lapped onto the top support steel or to the flexural capacity of the unreinforced concrete section given by the cracking moment  $m_{cr}$ .

Check:  $1.0 > 0.376 > 0.25$  – OK. So the extent of top steel into the end bay from support b must be at least:

$$c \times L = 0.376 \times 7500 = 2820 \text{ mm}$$

b)

Internal bay:



i) Assuming  $m' = 0$ , from Analysis Bay 2, Span b-c

$$m'_b = 74.3 \text{ kNm/m} \quad m'_c = 51.0 \text{ kNm/m}$$

With reference to Table 3.4, in order to compute 'c', first check  $m'$ :

$$m' \geq \frac{m'_b + m'_c}{2} - \frac{gL^2}{8}$$

we get

$$\begin{aligned} m' &\geq \frac{74.3 + 51.0}{2} - \frac{7 \times 7.5^2}{8} \\ &= 62.65 - 49.22 \end{aligned}$$

$$m' \geq 13.43 \text{ kNm/m}$$

Adding a 193 mesh<sup>o</sup> in the top at midspan - this would give

$$m' = 193 \times 0.95 \times 0.21 \times 0.438 \approx 17 \text{ kNm/m.}$$

As  $17 > 13.43$  OK and we get:

$$\begin{aligned} c &= 0.5 - \sqrt{0.25 - \frac{(m'_b + m'_c - 2m')}{gL^2}} \\ &= 0.5 - \sqrt{0.25 - \frac{(74.3 + 51.0 - 2 \times 17)}{7 \times 7.5^2}} \\ &= 0.365 \end{aligned}$$

Strictly, this value of c is valid only if the two support moments are equal i.e.  $m'_b = m'_c$ . As this is not the case, we can adjust c (or the curtailment of the top steel) as follows:

<sup>o</sup> See Ductility in *Frequently asked questions*

$$\frac{m'_b}{m'_c} = \frac{74.3}{51.0} = 1.46$$

then

$$1.46c + c = 2 \times 0.365$$

$$2.46c = 0.73 \quad \therefore c = \frac{0.73}{2.46} = 0.297$$

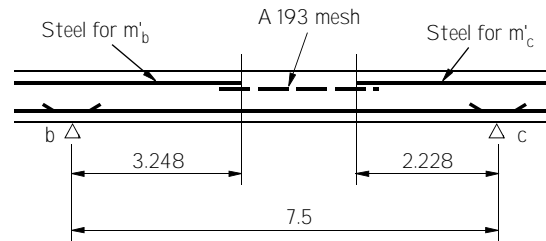
$$\therefore c_c = 0.297 \text{ and } c_b = 1.46 \times 0.297 = 0.433$$

So beyond support 'b' the extent is

$$0.433 \times 7500 = 3248 \text{ mm}$$

And beyond support 'c' the extent is

$$0.297 \times 7500 = 2228 \text{ mm}$$

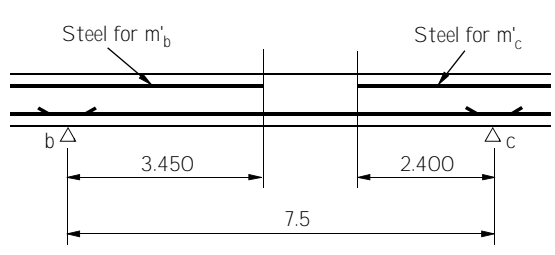


- ii) If we wanted to avoid hogging throughout the span and keep  $m' = 0$ , we would have to decrease the support moments  $m'_b$  and  $m'_c$  so that  $\frac{m'_b + m'_c}{2} = 49.22$ . Say 49.22 kNm/m each, but that option would entail redesigning the other spans

- iii) Another alternative would be to attribute a value to the moment of resistance of the unreinforced concrete section,  $m_{cr}^P$ .

$$\begin{aligned} m_{cr} &= \frac{R_f h^2}{6 \gamma_m} \text{ kNm/m} \\ &= 0.66 \times 0.55 \sqrt{40} \times 250^2 / (6 \times 1.5 \times 1000) \\ &= 15.9 \text{ kNm/m} \end{aligned}$$

<sup>P</sup>  $m'$  is the plastic hinge capacity which forms at the section where the top steel terminates and creates tension in the top fibres. The capacity at this section is either related to the area of reinforcement lapped onto the top support steel or to the flexural capacity of the unreinforced concrete section. This cracking moment  $m_{cr}$  is dependant on the flexural tensile strength of the concrete which is given by the expression  $f_r = 0.55 \sqrt{f_{cu}}$ . [N/mm<sup>2</sup>]. In order to allow for the effects of shrinkage, temperature etc. a reduction factor 'R' has been applied to the tensile strength. The actual value to be attributed to this factor is a matter of opinion and in this instance a 40 % reduction was considered appropriate. See Appendix.

iii) contd	<p>Where</p> <p><math>m_{CR}</math> is the moment of resistance of the unreinforced concrete section.</p> <p><math>R</math> is the reduction factor = say 0.66</p> <p><math>f_r</math> is the long-term tensile strength of concrete = <math>0.55\sqrt{f_{cu}}</math> N/mm<sup>2</sup></p> <p><math>h</math> is the slab depth mm.</p> <p>But let <math>m' = m_{cr} = 15.9</math> kNm/m</p> <p>This, not unreasonable, assumption gives</p> $c = 0.5 - \sqrt{0.25 - \frac{(74.3 + 51 - 2 \times 15.9)}{7 \times 7.5^2}} = 0.388$ <p>as before</p> $1.46c + c = 2 \times 0.388$ $2.46c = 0.776$ $\therefore c = \frac{0.776}{2.46} = 0.315$ <p>and <math>1.46 \times 0.315 = 0.460</math></p> $\therefore c_c = 0.315 \text{ and } c_b = 0.460$ <p>Beyond 'b' the extent of reinforcement required is</p>  $0.460 \times 7500 = \underline{3450 \text{ mm}}$ <p>and beyond 'c' the extent is</p> $0.315 \times 7500 = 2363, \text{ say } \underline{2400 \text{ mm}}$	
------------	---	--

### Commentary on calculations

In practice Example 3A and 3B would reduce to a couple of pages of hand calculations.

In this example knife-edge support widths are assumed, as would be the case of masonry wall supports, and centreline-to-centreline span are used. If, however, integral rc wall supports were used then clear spans, face-to-face of wall could have been used. Yield lines occur at the faces of integral walls or columns. In this case, it is safer to assume that the yield line occurs at the center of the masonry wall.

In the calculation for curtailment length, it was found that the cut-off point for the top reinforcement in the end bay was 0.376 of the end span measured from the internal support. This assumed  $m' = 0$ . However in the internal bay, we found that to avoid hogging throughout the span, i.e. to maintain  $m' = 0$ , would have involved reducing the size of the support moments  $m'_b$  and  $m'_c$  and recalculating span moments. This could have been done using cases 3 and 4 in Table 3.1.

Alternatively,  $m'$  could have been assigned a value. Section i) above used mesh, section iii) relied on the flexural tensile capacity of the concrete.

There are two schools of thought as to whether top steel (usually mesh) is required in the span of a slab or not. Strictly, if the top of the section is always going to be in compression, it is not required. However, many engineers advocate the use of mesh in the top of spans for the following reasons:

- to mitigate against shrinkage cracks,
- to help deal with temporary construction loading conditions,
- to improve robustness, especially in fire,
- to reduce deflection,
- to mitigate against cracking along construction joints.

ACI 318 [33] says, in effect, that unreinforced sections should not be used where ductility is required.

Nonetheless, most design codes recognise that concrete has some flexural strength. The use of 66% of  $0.55\sqrt{f_{cu}}$  for the allowable flexural tensile strength of concrete would appear to be justified. In cases where there is significant restraint, designers may choose to use a lower figure or indeed a higher figure where restraint is minimal. Further consideration is given to flexural tensile strength in the Appendix.

The investigation of curtailment has shown how the support moments derived from the all-spans-loaded case can be justified for the pattern load, i.e. alternate bays loaded, case.

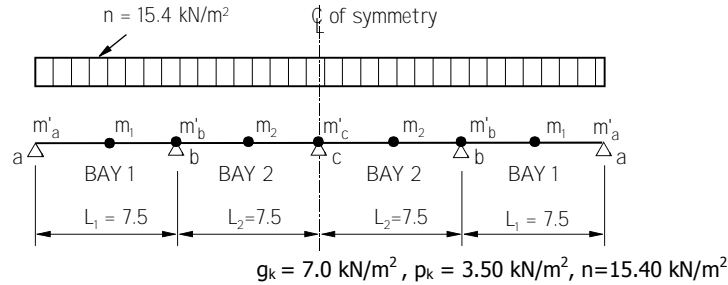
### Example 3C

#### One-way slab using formulae (Check for $m > 70\%$ elastic moment)

Clause 3.2.2.1 of BS 8110 stipulates that the resistance moment at any section should be at least 70% of the moment obtained from an elastic analysis covering all combinations. The following calculations are presented to demonstrate that there is rarely a problem and such calculations are unwarranted in the majority of cases.

The moments derived for example 3A will now be checked for compliance with Clauses 3.2.2.1 of BS 8110. It has already been shown earlier that the conditions of Clause 3.5.2.3 of BS 8110 were met and that it was therefore only necessary to cater for the case of all spans loaded with total load. With this type of load the following factored elastic moments can be established from Table 3.5. (To carry out this check unusually accurate values of  $m'_c$  and  $m_2$  will be required.)

Design procedure



Elastic moments (kNm/m)

$$m'_{be} = 0.1071 \times 15.4 \times 7.5^2 = 92.78$$

$$m'_{ce} = 0.0714 \times 15.4 \times 7.5^2 = 61.85$$

$$m_{2e} = 0.0364 \times 15.4 \times 7.5^2 = 31.53$$

$$m_{1e} = 0.0772 \times 15.4 \times 7.5^2 = 66.87$$

Comparison

Theory	Elastic moment (kNm/m)	Yield Line moment (kNm/m)	Yield Line moment/ Elastic moment
Location			
Bay 1	$m_{1e} = 66.87$	$m_1 = 74.3$	1.11
Sppt b	$m'_{be} = 92.78$	$m'_b = 74.3$	0.80
Bay 2	$m_{2e} = 31.53$	$m_2 = 51.0$ $= 47.69$	1.51 approx 1.62 exact*
Sppt c	$m'_{ce} = 61.85$	$m'_c = 51.0$ $= 47.69$	0.77 approx 0.82 exact*

\* from precise formulae - see footnote J to Example 3A

Nowhere are the redistributed moments less than 70% of the corresponding Elastic moments. Note that there is no limit by which a moment can be increased due to redistribution.

Check hogging moments at the points of contraflexure

In order to do this it is necessary to find the distance to the points of contraflexure for both the elastic and yield line distribution of moments. Formulae for calculating these distances ' $s_1$ ' are given in Table 3.2.

$$s_1 = L \frac{\sqrt{1+i_1} - 1}{\sqrt{1+i_1} + \sqrt{1+i_2}}$$



i) Choose Bay 2 at the end adjacent to support 'b':

Determine  $s_1$  for the elastic moments

$$i_1 = 92.78 / 31.53 = 2.94$$

$$i_2 = 61.85 / 31.53 = 1.96$$

$$s_1 = 7500 \times \frac{\sqrt{3.94} - 1}{\sqrt{3.94} + \sqrt{2.96}} = 1995 \text{ mm}$$

ii) Determine  $s_1$  for the yield line moments:

$$i_1 = 74.3 / 47.69 = 1.558$$

$$i_2 = 47.69 / 47.69 = 1.0$$

$$s_1 = 7500 \times \frac{\sqrt{2.558} - 1}{\sqrt{2.558} + \sqrt{2.0}} = 1492 \text{ mm}$$

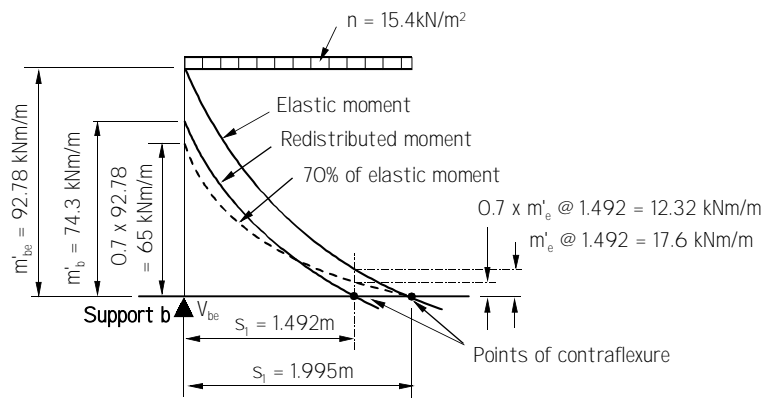


Diagram showing elastic and redistributed moments at support b in bay 2

The critical point to be investigated is at the redistributed moment point of contraflexure. Here, 1.492 m from b, the elastic moment theoretically becomes zero. In order to determine its initial magnitude, and determine the 70% limit, it is first necessary to calculate  $V_{be}$ .

$$V_{be} = 15.4 \times 7.5 / 2 + (92.78 - 61.85) / 7.5 = 61.874 \text{ kN}$$

$$m'_{e@1.492} = -92.78 - 15.4 \times 1.492^2 \times 0.5 + 61.875 \times 1.492 \\ = -17.6 \text{ kNm/m}$$

70% of this moment is  $0.7 \times -17.6 = -12.32 \text{ kNm/m}$

This is the hogging moment that Clause 3.2.2.1 stipulates has to be resisted (yet from the redistributed moment diagram theoretically there is no hogging moment at this point).

However good detailing practice requires top support reinforcement to be extended at least to a quarter of the span. In this particular case  $c_l$  was calculated to be 2625 mm, which is about a third of the span well beyond the point of contraflexure.

It can also be argued that concrete alone can resist a certain amount of tension as was established earlier showing that the cracking moment of resistance was 15.9 kNm/m which is  $> 12.32 \text{ kNm/m}$ .

Summary

This calculation was carried out to show that the check for the 70% rule in the vicinity of the point of contraflexure is not warranted for the majority of cases that are likely to occur in practice.

## 3.2 Two-way spanning slabs

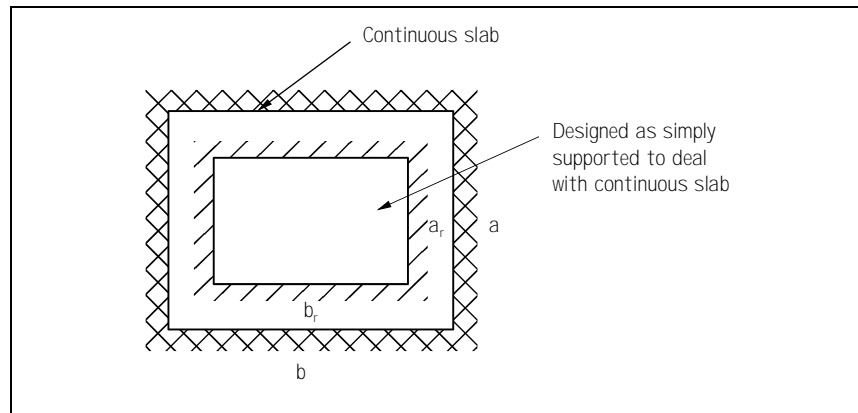
### 3.2.1 General

This section and the following deal with rectangular slabs supported on four, three or two sides, spanning in two directions.

Again, the formulae give the designer a wide choice for the magnitude of the support moments. These 'i' factors are chosen to reflect the kind of restraint offered by the support, expressed in terms of the ratio of the support to mid-span moments. The values commonly attributed to these 'i' factors are 0 for a simple support, giving no resistance to rotation, up to anything between 1 and 2, usually dependant on the rotational resistance offered by the continuing slab in the adjoining bay.

Wherever there is two-way action in a slab, the reinforcement in each direction is assumed to be stressed and to have yielded across a yield line. As explained in Chapter 2, in design a diagonal yield line (i.e. a yield line not at right angles to the reinforcement) is resolved into a stepped yield line with steps at right angles to the reinforcement. Again, the reinforcement crossing this diagonal yield line is assumed to yield. Usually these steps are projected onto two orthogonal axes of rotation and these projections are added to the length of the yield lines in both orthogonal directions.

One of the key concepts used in the design formulae of continuous two-way slabs is (as seen in Figure 3.4) to consider a continuous slab as containing a simply supported slab within the lines of contraflexure. The parameters  $a_r$  and  $b_r$  are the lengths of the sides, or reduced sides, of such a simply supported rectangular panel that produces the same midspan moments as the restrained panel with sides 'a' and 'b'.



**Figure 3.4** Principles of designing two-way slabs supported on four sides

The bottom reinforcement in the slab, as presented in these formulae, is assumed to have the same moment of resistance in each of the two directions at right angles to each other. This is called 'isotropic' reinforcement. This reinforcement is assumed to have the same effective depth in each direction, being the average of the effective depth in the two directions. When there are different quantities of bottom steel in each direction then the slab is said to be 'orthotropic'. No special formulae are necessary for orthotropic slabs, as there are simple rules available that convert an orthotropic case to an isotropic one.

The formulae for two-way slabs do not include for the effects of corner levers and it is therefore recommended that the '10% rule' is applied to the moments (or reinforcement areas) derived from formulae for two-way slabs. (See 1.2.11 and 1.2.12).

---

In the formulae for rectangular slabs supported on three or four sides, provision is made to include a line load parallel to the supports in each direction. This line load represents a heavy partition and is located in a position to create the maximum moment. It must be emphasized here that this is only valid if the line load is not the predominant load (see Partitions 3.2.3 below, otherwise a more onerous local failure pattern could develop).

### 3.2.2 Holding down forces

According to Yield Line Theory, at the ultimate limit state slabs supported on four sides produce uniformly distributed reactions in each support (Johansen [6]). The size of these reactions depends on the slab dimensions and their sum is higher than the applied load. This imbalance in equilibrium is redressed by holding down forces (or anchorage or negative reactions) in each corner. In a simply supported slab these forces represent the anchorage forces that would be required to prevent the corners from lifting off their supports.

### 3.2.3 Partition loads

Partitions are generally accounted for in a global uniformly distributed live load. When the line load from such a partition becomes exceptionally high, as would be the case with a dense, high party wall, then this is more appropriately dealt with as an independent line load. The formula used in Tables 3.6 and 3.7 is ideally suited for this purpose. There is, however, a limit to the size of such a line load for which the formula can be safely used. The limit depends on the size of the slab and support conditions and, for a rough estimate line load factors  $\alpha$  or  $\beta$  should be less than 0.35. When this is exceeded it would be necessary to resort to first principles by using the Work or Equilibrium Methods of analysis.

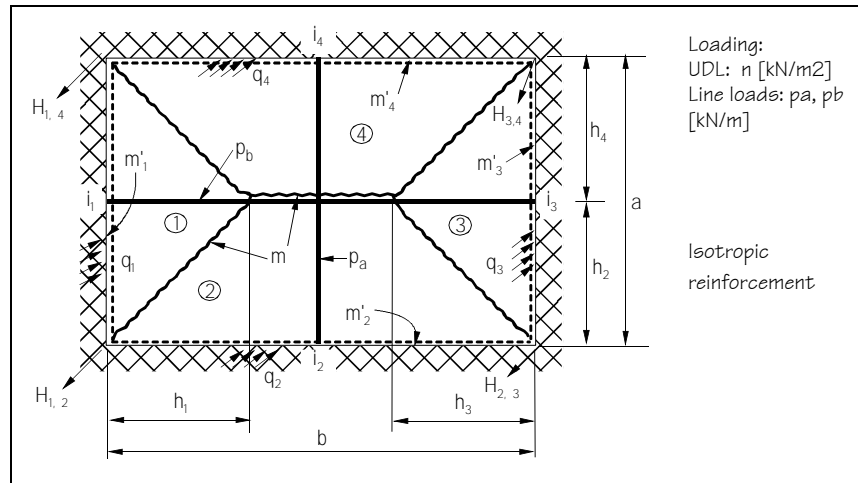
The interested reader can find further guidance on this topic on pages 23 - 24 and 117 - 118 of Johansen's *Yield Line Theory* [5] and pages 32 - 33 of his *Yield Line formulae for slabs* [6].

## 3.3 Two-way slabs - supports on 4 sides

### 3.3.1 General

In essence, the design moment,  $m$ , of a slab supported on four sides is determined by considering the central part of a continuous slab as being a simply supported slab, of reduced side lengths, supported at the points of contraflexure. Moments at continuous supports, or at least the fixity ratios at the supports, are chosen by the designer. Uniformly distributed loads and reduced side lengths can be adjusted to accommodate line loads.

The formulae for determining moments, reactions and defining dimensions to the failure pattern in two-way spanning slabs supported on four sides as illustrated by Figure 3.5 are given in Tables 3.6a and 3.6b.



**Figure 3.5** Slab supported on four sides

Where

- $m$  is the ultimate moment along the yield line (sagging) [kNm/m]
- $m'$  is the ultimate moment along the yield line (hogging) [kNm/m]
- $p_a, p_b$  are the line loads (partitions) [kN/m]
- $n$  is the total ultimate uniformly distributed load,  $1.4g_k + 1.6p_k$  [kN/m<sup>2</sup>]
- $q$  is the reaction [kN/m]
- $a, b, h$  are the dimensions [m]
- $H$  is the holding down forces at corners [kN]
- $i_1, i_2, i_3, i_4$  are the fixity, the ratios  $m'/m$  for regions 1, 2, 3 and 4 .

**Table 3.6a** Formulae for slabs supported on four sides

Fixity ratios <sup>Q</sup>	$i_1 = \frac{m'_1}{m} \quad i_2 = \frac{m'_2}{m} \quad i_3 = \frac{m'_3}{m} \quad i_4 = \frac{m'_4}{m}$
Line load factors	$\alpha = \frac{p_a}{n \times b} \qquad \qquad \qquad \beta = \frac{p_b}{n \times a}$  but if no line loads: $p_a = p_b = 0, \alpha = \beta = 0.$
Reduced sides <sup>R</sup>	$a_r = \frac{2a}{\sqrt{1+i_2} + \sqrt{1+i_4}} \quad [m] \qquad \qquad b_r = \frac{2b}{\sqrt{1+i_1} + \sqrt{1+i_3}} \quad [m]$
Adjusted load (adjusted to account for relatively light line loads)	$n^* = n(1 + \alpha + 2\beta) \quad [kN/m^2]$
Adjusted reduced side	$b_r^* = b_r \sqrt{\frac{1 + \alpha + 2\beta}{1 + 3\beta}} \quad [m]$
Design moment <sup>S</sup>	$m = \frac{n^* \times a_r \times b_r^*}{8 \left( 1 + \frac{b_r^*}{a_r} + \frac{a_r}{b_r^*} \right)} \quad [kNm/m]$

continued

<sup>Q</sup> In order to evaluate the moment 'm' a choice has to be made for the degree of fixity by way of choosing  $i_1 - i_4$  along the four sides of the slab. The same principles for determining their values apply as discussed under the One-way spanning slabs. For a simple support this value is put to zero.

<sup>R</sup> The parameters  $a_r$  and  $b_r$  are the lengths of a simply supported rectangular panel that produces the same midspan moments as the restrained panel with sides 'a' and 'b'. These parameters are often referred to as 'reduced sides'.

<sup>S</sup> The expression for evaluating the moment 'm' given here is a simplified version of the more rigorous formula, i.e.

$$m = \frac{na_r^2}{24} \left[ \sqrt{3 + \left( \frac{a_r}{b_r} \right)^2} - \frac{a_r}{b_r} \right]^2 \quad (\text{valid only without line loads and for } b_r \geq a_r)$$

The abridged version has the advantage of being easy to memorize and because the variables  $a_r$  and  $b_r$  occur symmetrically in the formula it does not require  $b_r$  to be  $\geq a_r$ . It gives results about 3% on the safe side. For design purposes it is recommended that this moment is increased by an additional 7% to bring the overall increase up to the level of the '10% rule' to allow for the effect of corner levers forming etc. The designer may of course choose to add 10%.

**Table 3.6b** Formulae for slabs supported on four sides (continued)

Dimensions $h_i$	$h_1 = \sqrt{6(1+i_1) \frac{m}{n(1+3\beta)}} \quad [m]$ $h_2 = \frac{a_r}{2} \sqrt{1+i_2} \quad [m]$	$h_3 = \sqrt{6(1+i_3) \frac{m}{n(1+3\beta)}} \quad [m]$ $h_4 = \frac{a_r}{2} \sqrt{1+i_4} \quad [m]$
Reactions <sup>†</sup>	$Q_1 = 4m \left( \frac{1}{a_r} + \frac{1}{b_r} \right) \times \sqrt{1+i_1} \quad [kN/m]$ $Q_2 = 4m \left( \frac{1}{a_r} + \frac{1}{b_r} \right) \times \sqrt{1+i_2} \quad [kN/m]$	$Q_3 = 4m \left( \frac{1}{a_r} + \frac{1}{b_r} \right) \times \sqrt{1+i_3} \quad [kN/m]$ $Q_4 = 4m \left( \frac{1}{a_r} + \frac{1}{b_r} \right) \times \sqrt{1+i_4} \quad [kN/m]$
Negative reactions (or holding down forces)	$H_{1,2} = 2m \sqrt{1+i_1} \times \sqrt{1+i_2} \quad [kN]$ $H_{2,3} = 2m \sqrt{1+i_2} \times \sqrt{1+i_3} \quad [kN]$	$H_{3,4} = 2m \sqrt{1+i_3} \times \sqrt{1+i_4} \quad [kN]$ $H_{1,4} = 2m \sqrt{1+i_1} \times \sqrt{1+i_4} \quad [kN]$
<p><b>NB</b> These reactions apply only to slabs supported on four sides without line loads. Where there are line loads use engineering judgement to determine reactions (- the full theory is very involved!)</p>		
Assuming isotropic reinforcement. Definitions as above or as before.		

<sup>†</sup> When designing beams to the Elastic Theory, it has long been common practice to consider the distribution of load as that given by triangles and trapezoids with base angles of 45 degrees. This distribution is quite accurate provided, of course, that the beams are of adequate stiffness. Park and Gambale [11] have shown that if the loading distribution on the beams at collapse is taken to follow the shape of the segments of the yield line pattern, then the maximum ultimate moments calculated for the beams are identical with those calculated considering composite collapse mechanisms. This was also shown by Wood [13] and Wood & Jones [14].

The values for the distribution and magnitude of reactions given in Table 3.6 are those given by Johansen [6] for a slab carrying a uniformly distributed load only supported on stiff beams that do not deflect appreciably. Johansen showed the reactions to be evenly distributed along all four sides. The magnitude of the reactions depends on the slab dimensions and the moments induced. These reactions are accompanied by negative holding down forces at the corners of the slab. As ever equilibrium must always exist between the total downward load on the slab, the reactions and the holding down forces at the corners.

It has to be said, however, that theoretically the Yield Line Theory, being an upper bound kinematic technique, does not strictly offer any factual information on the distribution of stress-resultants (i.e. reactions and loads) remote from the yield lines themselves. Although true, the designer does need some guidance on the distribution of load onto beams. Provided the assumptions made are reasonable and equilibrium of external loads is maintained the approximations in the approach given above should be acceptable for design purposes.

It must be stressed that the distribution of reactions can only be realized if the supporting beams are strong enough and stiff enough to carry the load without excessive deflection. If this is not the case then the load carried by the beam changes dramatically as the beam will fail compositely with the slab and the way the load will be divided between the slab and the beam will be determined solely by their respective ultimate moments of resistance.

The formulae given in Table 3.6 for these reactions are valid only for the uniformly distributed load and should not be used when line loads are present.

## Example 3D

### Two-way slab using formulae (with udl and line load)

Using formulae, analyse and design the same 250 mm thick r.c. slab as in Examples 2A and 2B. It is 9.0 by 7.5 m and occupies a corner bay of a floor that has columns at each corner connected by stiff beams in each direction. Allow for a total ultimate load of 20 kN/m<sup>2</sup>. Concrete is C40, cover 20 mm T&B.

Establish what the effect would be on the amount of reinforcement required if there were a need to allow for a heavy partition weighing 20 kN/m (ult.) to be added in any location on the slab.

Design procedure	
Floor layout	
Analysis; initially with udl only	
<p>Corner bay slab supported on beams: with reference to Table 3.6a we get:</p> $m'_1 = i_1 m$ $m'_2 = i_2 m$	
<p>Determine moments:</p> <p>Choosing<sup>u</sup> <math>i_1 = i_2 = 1</math> and <math>i_3 = i_4 = 0</math></p> $a_r = \frac{2a}{\sqrt{1+i_2} + \sqrt{1+i_4}} = \frac{2 \times 7.5}{\sqrt{2} + \sqrt{1}} = 6.213$ $b_r = \frac{2b}{\sqrt{1+i_1} + \sqrt{1+i_3}} = \frac{2 \times 9}{\sqrt{2} + \sqrt{1}} = 7.456$	

<sup>u</sup> **Analysis:** In this instance it was assumed that the adjoining bays are of similar spans so that an 'i' value of 1.0 was considered appropriate for the two continuous sides.

As there is no line load:

$$\alpha = \beta = 0 \text{ therefore } n^* = n \text{ and } b_r^* = b_r$$

$$m = \frac{n a_r b_r}{8 \left( 1 + \frac{b_r}{a_r} + \frac{a_r}{b_r} \right)} = \frac{20 \times 6.213 \times 7.456}{8 \left( 1 + \frac{7.456}{6.213} + \frac{6.213}{7.456} \right)}$$

$$m = \underline{38.18 \text{ kNm/m}}$$

$$m'_1 = i_1 m = \underline{38.18 \text{ kNm/m}}$$

$$m'_2 = i_2 m = \underline{38.18 \text{ kNm/m}}$$

Check dimensions<sup>v</sup>

Check that  $h_1 + h_3 \leq b$

$$h_1 = \sqrt{6(1+i_1) \frac{m}{n}} = \sqrt{6 \times 2 \times \frac{38.18}{20}} = 4.78 \text{ m}$$

$$h_3 = \sqrt{6(1+i_3) \frac{m}{n}} = \sqrt{6 \times 1 \times \frac{38.18}{20}} = 3.38 \text{ m}$$

$$4.78 + 3.38 = 8.16 < 9.0 \quad \underline{O.K.}$$

Check that  $h_2 + h_4 = a$

$$h_2 = \frac{a_r}{2} \sqrt{1+i_2} = \frac{6.213}{2} \sqrt{2} = 4.39 \text{ m}$$

$$h_4 = \frac{a_r}{2} \sqrt{1+i_4} = \frac{6.213}{2} \sqrt{1} = 3.11 \text{ m}$$

$$4.39 + 3.11 = 7.5 \quad \underline{O.K.}$$

Reactions:

$$\begin{aligned} q_1 &= 4m \left( \frac{1}{a_r} + \frac{1}{b_r} \right) \times \sqrt{1+i_1} \\ &= 4 \times 38.18 \left( \frac{1}{6.213} + \frac{1}{7.456} \right) \times \sqrt{2} \quad q_1 = \underline{63.73 \text{ kN/m}} \end{aligned}$$

$$\begin{aligned} q_2 &= 4m \left( \frac{1}{a_r} + \frac{1}{b_r} \right) \times \sqrt{1+i_2} \\ &= 4 \times 38.18 \left( \frac{1}{6.213} + \frac{1}{7.456} \right) \times \sqrt{2} \quad q_2 = \underline{63.73 \text{ kN/m}} \end{aligned}$$

$$\begin{aligned} q_3 &= 4m \left( \frac{1}{a_r} + \frac{1}{b_r} \right) \times \sqrt{1+i_3} \\ &= 4 \times 38.18 \left( \frac{1}{6.213} + \frac{1}{7.456} \right) \times \sqrt{1} \quad q_3 = \underline{45.06 \text{ kN/m}} = q_4 \end{aligned}$$

<sup>v</sup>The values for  $h_1$ ,  $h_2$ ,  $h_3$  and  $h_4$  are also used in Example 2B.



$$H_{1,2} = 2m\sqrt{1+i_1} \times \sqrt{1+i_2} = 2 \times 38.18 \sqrt{2} \times \sqrt{2} = \underline{152.72 \text{ kN}}$$

$$\begin{aligned} H_{1,4} = H_{2,3} &= 2m\sqrt{1+i_1} \times \sqrt{1+i_4} = 2m\sqrt{1+i_2} \times \sqrt{1+i_3} \\ &= 2 \times 38.18 \sqrt{2} \times \sqrt{1} = \underline{108 \text{ kN}} \end{aligned}$$

$$H_{3,4} = 2m\sqrt{1+i_3} \times \sqrt{1+i_4} = 2 \times 38.18 \sqrt{1} \times \sqrt{1} = \underline{76.36 \text{ kN}}$$

Check loads against reactions and holding down forces:

$$\text{Total load on slab: } 20 \times 9 \times 7.5 = 1350 \text{ kN}$$

Total reaction on beams:

$$63.73 \times (9 + 7.5) + 45.06 \times (9 + 7.5) = 1795.04 \text{ kN}$$

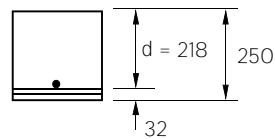
Total holding down forces at corners:

$$152.72 + 108 \times 2 + 76.36 = 445.08 \text{ kN}$$

$$\text{Thus } 1795.04 - 445.08 = 1349.96 \text{ kN}$$

$$\text{i.e. } \underline{1350 \approx 1349.96 \text{ O.K.}^w}$$

Design



$$d_{ave} = 250 - 20 - 12 = 228 \text{ mm}$$

$$\frac{m}{bd^2 f_{cu}} = \frac{38.18 \times 10^6}{10^3 \times 218^2 \times 40} = 0.02 \quad \therefore z = 0.95d$$

$$A_{s_{req,d}} = \frac{38.18}{0.95 \times 0.218 \times 0.438} = 420.9 \text{ mm}^2/\text{m}$$

Provide T12 @ 250 cc (452 mm<sup>2</sup>/m) each way bottom and at the top along sides a and b where slab is continuous.

This is slightly less than the 10% increase usually recommended, but referring to the footnote to 'Design Moment' in Table 3.6a, 7% increase would be adequate to allow for corner levers.

$$As \frac{452}{420.9} = 1.074 > 7\% \text{ increase } \underline{\text{OK}}$$

<sup>w</sup> **Reactions:** It is of interest to note that, although equilibrium of vertical forces does exist, the total reaction carried by the beams is some 30% more than the total slab load. This is because the negative holding down forces at the slab corners affect only the load transmitted to the columns thus ensuring that the total load carried by them equals the load from the slab. As far as the beams are concerned, the moments in them calculated from this uniformly distributed load will not differ substantially from the moments if they were calculated in the more familiar way from the tributary areas formed by the yield line pattern. The shear forces to be allowed for, however, will be greater.

Deflection

Serviceability check<sup>x</sup> similar to that in Example 5A:

Applying Cl. 3.4.6.5 from BS 8110 we get:

$$\beta_b = 1.1 \quad A_{s_{req}} = 420.9 \quad A_{s_{prov}} = 452$$

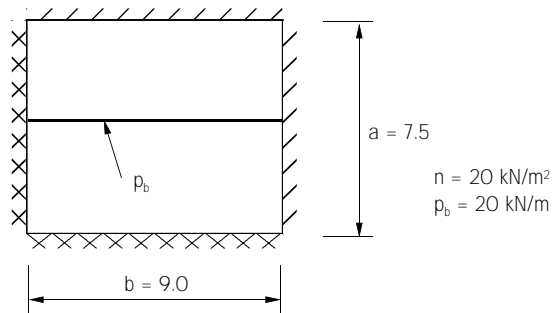
$$d = 218 \quad m = 38.18 \quad L = 7.5 \quad \therefore f_s = 259.6 \text{ and } k_1 = 1.614, \text{ i.e.}$$

$$L/d \text{ required} = 26 \times 1.614 = 42$$

$$L/d \text{ provided} = \frac{7500}{218} = 34.4$$

$$\text{as } 34.4 < 42 \quad \underline{\text{OK}}$$

Consider additional partition load of 20 kN/m<sup>y</sup>



First try partition parallel with 'b'

$$\alpha = 0 \quad \beta = \frac{p_b}{na} = \frac{20}{20 \times 7.5} = 0.133$$

$$n^* = n(1 + \alpha + 2\beta) = 20(1 + 0 + 2 \times 0.133) \\ = 25.33 \text{ kNm/m}$$

$$a_r = 6.213 \text{ m as before}$$

$$b_r^* = b_r \sqrt{\frac{1 + \alpha + 2\beta}{1 + 3\beta}} = 7.456 \sqrt{\frac{1 + 2 \times 0.133}{1 + 3 \times 0.133}} \\ = 7.092$$

$$m = \frac{n^* \times a_r \times b_r^*}{8 \left( 1 + \frac{b_r^*}{a_r} + \frac{a_r}{b_r^*} \right)} = \frac{25.33 \times 6.213 \times 7.092}{8 \left( 1 + \frac{7.092}{6.213} + \frac{6.213}{7.092} \right)}$$

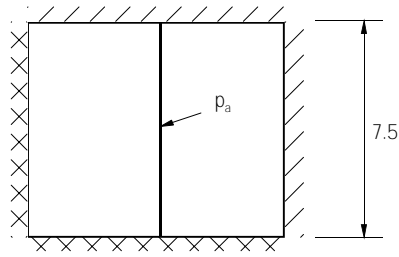
$$= 48.24 \text{ kNm/m} = m' = m'_1 = m'_2$$

<sup>x</sup> **Deflection:** Deflection in two-way spanning slabs is always checked for the shorter span. Otherwise the procedure follows the same principles as in the One-way spanning slabs.

<sup>y</sup> **Partition load:** See Section 3.2.3 *Partition loads*. As the line load is relatively small ( $\beta = 0.133$  i.e.  $\ll 0.35$ ), use of formulae is OK.

The supporting beams have been defined as 'stiff' so that the slab can be regarded as being supported on all four sides and therefore, at ultimate load, only the slab will fail leaving the beams intact. See section 4.4 *How to tackle slabs with beams* for when beams can be regarded as line supports – i.e. when they do not fail with the slab.

Now check for partition parallel with 'a'



$$\text{Then } \alpha = \frac{Pa}{nb} = \frac{20}{20 \times 9} = 0.111 \quad \beta = 0$$

$$n^* = 20(1 + 0.111) = 22.2 \text{ kN/m}^2$$

$\therefore$  as  $22.2 < 25.3$ , partition parallel with 'b' is critical

Design with partition

$$A_{s_{req}} = \frac{46.24}{0.95 \times 0.218 \times 0.438} = 510 \text{ mm}^2 / \text{m}$$

Provide T12 @ 200 cc (565 mm<sup>2</sup>/m)

Deflection

$$\text{Say } \beta_p = 1.1 \quad A_{s_{req}} = 510 \quad A_{s_{prov}} = 565 \quad d = 218$$

$$m = 46.24 \quad L = 7.5 \quad \therefore f_s = 252$$

$$k_1 = 1.55 \text{ i.e. } L/d \text{ needed} = 26 \times 1.55 = 40.37$$

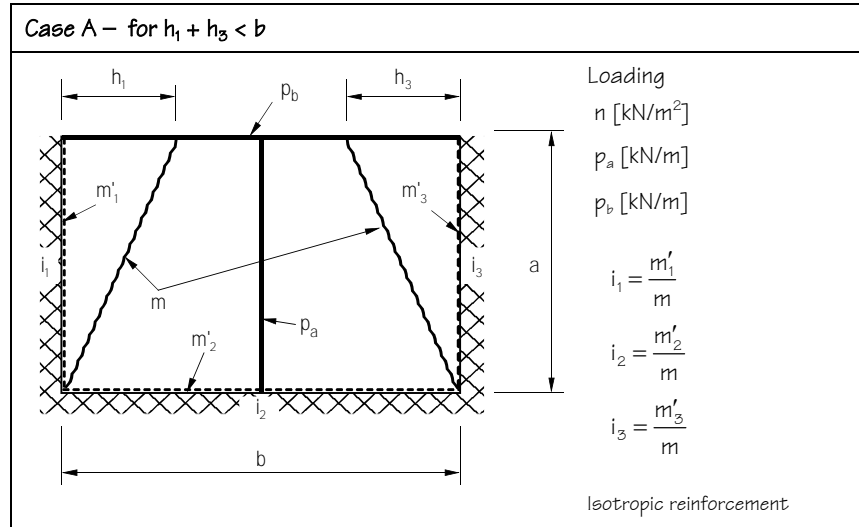
$$L/d \text{ provided} = 34.4: \text{ as } 34.4 < 40.37 \quad \underline{\text{O.K.}}$$

Conclusion

Due to the addition of a line load of 20 kN/m in the most onerous location on the slab the reinforcement has to be increased from T12 @ 250 to T12 @ 200 in all locations.

### 3.4 Two-way slabs – supports on 3 sides

The basic yield line patterns that can develop in slabs with one free edge are indicated in the two cases shown in Figures 3.6 and 3.7. The correct pattern depends on the slab dimensions and boundary conditions. Broadly speaking the case shown in Figure 3.6 is more likely to occur when the side 'b' is greater than 'a' but when the difference between the two is not significant then either case can be relevant. If this is the case then both sets of formulae must be evaluated and, if both are found to be valid, then the greater moment should be chosen.



**Figure 3.6** Rectangular slab supported on 3 sides, Case A where  $h_1 + h_3 < b$

**Table 3.7** Formulae for rectangular slabs supported on 3 sides, Case A where  $h_1 + h_3 < b$  [6]

Line load factors

$$\alpha = \frac{p_a}{n \times b} \quad \beta = \frac{p_b}{n \times a}$$

but if no line loads:  $p_a = p_b = 0, \alpha = \beta = 0$ .

Moments

$$m = \frac{n \times a \times b_r (1 + \alpha + 2\beta)}{8 \left( \frac{i_2 b_r}{4a} + \frac{a}{h} \right)}$$

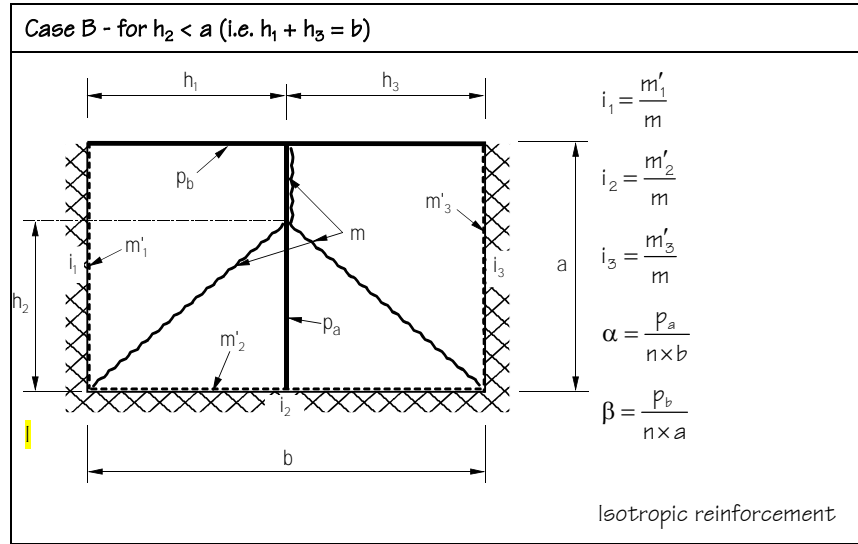
Dimensions

$$b_r = \frac{2b}{\sqrt{1+i_1} + \sqrt{1+i_3}}$$

$$h_1 = h\sqrt{1+i_1} \quad h_3 = h\sqrt{1+i_3}$$

where  $h = \frac{a}{K + \sqrt{K^2 + \frac{i_2 b_r K}{2a} + 1}}$  and  $K = \frac{2a(1+3\beta)}{3b_r(1+\alpha+2\beta)}$

Key as Table 3.8



**Figure 3.7** Rectangular slab supported on three sides, Case B where  $h_2 < a$  (or  $h_1 + h_3 = b$ )

**Table 3.8** Formulae for rectangular slabs supported on 3 sides, Case B where  $h_2 < a$  [6]

Line loads factors:

$$\alpha = \frac{p_a}{n \times b} \quad \beta = \frac{p_b}{n \times a}$$

but if no line loads:  $p_a = p_b = 0, \alpha = \beta = 0$ .

Moments

$$m = \frac{n' \times a' \times b'}{8 \left( 1 + \frac{b'}{a'} + \frac{a'}{b'} \right)}$$

where

$$n' = n \times (1 + \beta + 2\alpha)$$

$$a' = b_r = \frac{2b}{\sqrt{1+i_1} + \sqrt{1+i_3}}$$

$$b' = \frac{2a}{\sqrt{1+i_2}} \sqrt{\frac{1+\beta+2\beta}{1+3\alpha}}$$

Dimensions

$$h_1 = \frac{b_r}{2} \sqrt{1+i_1}, \quad h_2 = \sqrt{\frac{8m(1+i_2)}{n(1+3\alpha)}}, \quad h_3 = \frac{b_r}{2} \sqrt{1+i_3}$$

Where

- m is the span moment in each orthogonal direction
- m' is the support moment
- $p_a, p_b$  are the line loads (partitions) [kN/m]
- n is the total ultimate Uniformly distributed load,  $1.4g_k + 1.6p_k$  [kN/m<sup>2</sup>]
- a, b are the dimensions [m]
- i is the fixity, the ratio  $m'/m$  for  $i_1, i_2, i_3$ .
- $b_r$  is the reduced span 'b'
- a' and b' are the dimensions allowing for line loads
- n' is the ultimate uniformly distributed load allowing for line loads
- h is the factor to determine  $h_1$  and  $h_3$

For design purposes, the moment given by the formula should be increased by 10% to allow for the effects of corner levers forming,.

Again, the formulae incorporate a provision for a heavy, but not predominant, line load along the free edge and at right angles to it in the most onerous position. Reactions for this type of slab are more complex to evaluate and are beyond the scope of this publication. They are explained in detail in Johansen's *Yield Line theory* [5, 6].

## Example 3E

### Two-way slab using formulae (supported on 3 sides)

Analyse and design a 250 thick r.c. slab 9.0 x 5.0 m supported on walls on three sides with one 9.0 m span unsupported. Two adjacent supported sides are continuous with slabs of similar spans. Allow for a total ultimate distributed load of 20 kN/m<sup>2</sup>. Concrete C40, cover 20 mm T&B.

Design procedure

Slab layout

Line load  $p_a = 10 \text{ kN/m}$       Line load  $p_b = 20 \text{ kN/m}$

250mm slab

Wall supports

$n = 20 \text{ kN/m}^2$

Slab depth = 250 mm, Concrete C40, Cover 20 mm T&B

---

Analysis<sup>z</sup>

Case 1a      Rectangular slab supported on three sides: with reference to Table 3.7, we get:

Choose  $i_1 = i_2 = 1$  and  $i_3 = 0$   
 $m'_1 = i_1 m$  and  $m'_2 = i_2 m$

<sup>z</sup> **Analysis:** Because the side 'b' is considerably greater than side 'a' there is no difficulty in choosing 'case 1a' as being the appropriate one to use in this example.

$$\alpha = \frac{p_a}{n \times b} = \frac{10}{20 \times 9} = 0.056$$

$$\beta = \frac{p_b}{n \times a} = \frac{20}{20 \times 5} = 0.20$$

$$b_r = \frac{2b}{\sqrt{1+i_1} + \sqrt{1+i_3}} = \frac{2 \times 9}{\sqrt{2} + \sqrt{1}} = 7.456$$

$$K = \frac{2a(1+3\beta)}{3b_r(1+\alpha+2\beta)} = \frac{2 \times 5 \times (1+3 \times 0.2)}{3 \times 7.456 \times (1+0.056+2 \times 0.2)} = 0.49$$

$$h = \frac{a}{K + \sqrt{K^2 + \frac{i_2 b_r K}{2a} + 1}} = \frac{5}{0.49 + \sqrt{0.49^2 + \frac{7.456 \times 0.49}{2 \times 5} + 1}} = 2.846$$

$$m = \frac{nab_r(1+\alpha+2\beta)}{8 \left( \frac{i_2 b_r}{4a} + \frac{a}{h} \right)} = \frac{20 \times 5 \times 7.456 (1+0.056+2 \times 0.2)}{8 \left( \frac{7.456}{4 \times 5} + \frac{5}{2.846} \right)} = \underline{63.72 \text{ kNm/m}}$$

$$m'_1 = i_1 m = 63.72 \text{ kNm/m} = m'_2 = i_2 m$$

$$h_1 = h\sqrt{1+i_1} = 2.846\sqrt{2} = 4.025 \text{ m}$$

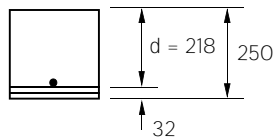
$$h_3 = h\sqrt{1+i_3} = 2.846\sqrt{1} = 2.846 \text{ m}$$

Check:  $h_1 + h_3 < b$   
 $4.025 + 2.846 = 6.871 < 9.0$  therefore O.K.

i.e. case 1a is a valid solution

Design

$$d_{ave} = 250 - 20 - 12 = 218$$



$$\frac{m}{bd^2 f_{cu}} = \frac{63.72 \times 10^6}{10^3 \times 218^2 \times 40} = 0.034 \quad \therefore z = 0.95d$$

$$A_{s, req} = \frac{63.72}{0.95 \times 0.218 \times 0.438} = 702.5 \text{ mm}^2 / \text{m}$$

Provide T12 @ 150 cc (754 mm<sup>2</sup>/m)

(As before this is a 7% increase which would be adequate to allow for the effects of corner levers [see footnote to Table 3.6a] but the design reinforcement may have to be increased further to reduce deflection especially towards the free edge)



Deflection<sup>AA</sup>Applying Cl. 3.4.6.5 from BS8110<sup>BB</sup> we get:

$$\beta_b = 1.1 \quad A_{s_{req}} = 702.5 \quad A_{s_{prov}} = 754$$

$$d = 218 \quad m = 63.72 \quad L = 9 \text{ m} \quad \therefore f_s \approx 260 \text{ and } k_1 = 1.358, \text{ i.e.:$$

$$L/d_{required} = 26 \times 1.358 = 35.31$$

$$L/d_{provided} = \frac{9000}{218} = 41.28$$

as  $41.28 > 35.31$  NOT O.K.

So we have to increase the area of reinforcement provided in order to reduce strain

Try T12 @ 100 cc (1131 mm<sup>2</sup>/m)

Then:

$$f_s = 173.16 \quad k_1 = 1.68$$

$$L/d_{required} = 26 \times 1.68 = 43.68$$

$$\text{as } 41.28 < 43.68 \text{ O.K.}$$

Note:  $\frac{1131}{702.5} = 1.6$ : 60% increase for deflection purposes only. This is

$1131/702.5 = 1.6$ , well in excess of the 10% recommended to allow for corner levers  $\therefore$  O.K.

<sup>AA</sup> **Deflection:** Slabs supported on three sides with the long edge unsupported will always be very vulnerable to the deflection occurring at the middle of this edge. If it is crucial to limit this deflection due to sensitive cladding then a rigorous deflection calculation has to be carried out using a Finite Element Analysis or similar. In that case the span/depth method of the code cannot be regarded as being adequate.

<sup>BB</sup> Serviceability check similar to that in Example 3A and 3D.

### Example 3F

#### Two-way slab using formulae (supported on 3 sides with line load)

Analyse and design a slab  $5.5 \times 5.0$  m supported on walls on three sides with one 5.5 m span unsupported. Two adjacent supported sides are continuous with slabs of similar spans. Allow for a total ultimate distributed load of  $15 \text{ kN/m}^2$  and an ultimate line load of  $20 \text{ kN/m}$  along the unsupported edge. Assume the slab is 200 mm deep with isotropic reinforcement, concrete C40, cover 20 mm T&B.

Design procedure

Slab layout

Line load  $p_b = 20 \text{ kN/m}$

200 mm slab

5.5

5

SECTION 2 - 2

Wall supports

$n = 15 \text{ kN/m}^2$

SECTION 1 - 1

Slab depth = 200 mm, Concrete C40, Cover 20 mm T&B.

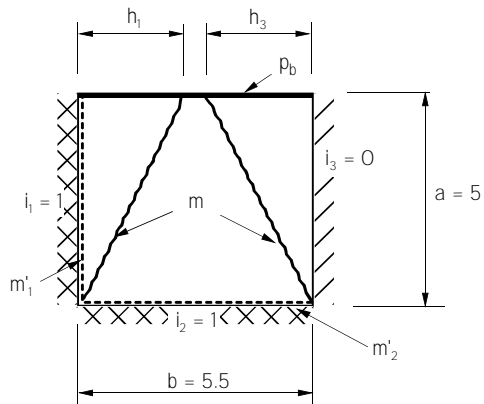
isotropic reinforcement

Analysis<sup>cc</sup>

Rectangular slab supported on three sides. Because the difference in length of the sides  $a$  and  $b$  is not pronounced, we need to evaluate both possible modes of failure in cases 1a and 1b to establish the worst case. With reference to Tables 3.7 and 3.8 we get:

<sup>cc</sup> **Analysis:** Here the side 'b' is only marginally greater than side 'a' so it is not possible to predict which of the two cases is going to be the right one. So we have to try both to see which one gives a more onerous solution. Because in this instance our case is a near transitional one the moment generated by each of the solutions is virtually identical.

Case 1a

Choose  $i_1 = i_2 = 1$   $i_3 = 0$ 

$$m'_1 = i_1 m, \quad m'_2 = i_2 m$$

$$\alpha = 0; \quad \beta = \frac{p_b}{n \times a} = \frac{20}{15 \times 5} = 0.266$$

$$b_r = \frac{2b}{\sqrt{1+i_1} + \sqrt{1+i_3}} = \frac{2 \times 5.5}{\sqrt{2} + \sqrt{1}} = 4.56$$

$$K = \frac{2a(1+3\beta)}{3b_r(1+\alpha+2\beta)} = \frac{2 \times 5 \times (1+3 \times 0.266)}{3 \times 4.56 \times (1+2 \times 0.266)} = 0.86$$

$$h = \frac{a}{K + \sqrt{K^2 + \frac{i_2 b_r K}{2a} + 1}} = \frac{5}{0.86 + \sqrt{0.86^2 + \frac{4.56 \times 0.86}{2 \times 5} + 1}} = 2.158$$

$$m = \frac{n \times a \times b_r (1+\alpha+2\beta)}{8 \left( \frac{i_2 b_r}{4a} + \frac{a}{h} \right)} = \frac{15 \times 5 \times 4.56 (1+2 \times 0.266)}{8 \left( \frac{4.56}{4 \times 5} + \frac{5}{2.158} \right)} = 25.75 \text{ kNm/m}$$

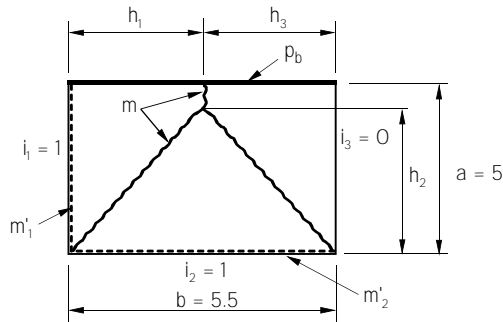
$$h_1 = h \sqrt{1+i_1} = 2.158 \sqrt{2} = 3.05 \text{ m}$$

$$h_3 = h \sqrt{1+i_3} = 2.158 \sqrt{1} = 2.158 \text{ m}$$

As  $h_1 + h_3 = 3.05 + 2.158 = 5.208 < 5.5$  (b), this is a valid solution.

But try Case 1b:

Case 1b



Choose  $i_1 = i_2 = 1$ ;  $i_3 = 0$ ;  $m'_2 = i_1 m$ ;  $m'_2 = i_2 m$

$\alpha = 0$ ;  $\beta = 0.266^\circ$

$a' = b_r = 4.56$  m (as before for case 1a)

$$b' = \frac{2a}{\sqrt{1+i_2}} \sqrt{\frac{1+\beta+2\alpha}{1+3\alpha}} = \frac{2 \times 5}{\sqrt{2}} \sqrt{\frac{1+0.266}{1}} = 7.96$$

$$n' = n(1+\beta+2\alpha) = 15(1+0.266) = 19 \text{ kN/m}^2$$

$$m = \frac{n' + a' + b'}{8 \left( 1 + \frac{b'}{a'} + \frac{a'}{b'} \right)} = \frac{19 + 4.56 + 7.96}{8 \left( 1 + \frac{7.96}{4.56} + \frac{4.56}{7.96} \right)} = 25.98 \text{ kNm/m}$$

$$m'_1 = i_1 m = 25.98 \text{ kNm/m}$$

$$m'_2 = i_2 m = 25.98 \text{ kNm/m}$$

$$\left. \begin{aligned} h_1 &= \frac{b_r}{2} \sqrt{1+i_1} = \frac{4.56}{2} \sqrt{2} = 3.22 \\ h_3 &= \frac{b_r}{2} \sqrt{1+i_3} = \frac{4.56}{2} = 2.28 \end{aligned} \right\} 5.5 = b$$

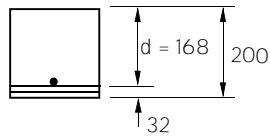
$$h_2 = \sqrt{\frac{6m\sqrt{1+i_2}}{n(1+3\alpha)}} = \sqrt{\frac{6 \times 25.98 \times \sqrt{2}}{15}} = 3.83$$

As  $h_2 = 3.83 < 5.0$  then case 1b is also a valid solution.

As Case 1b gives the greater moment, use case 1b in the design

## Design

$$d_{ave} = 200 - 20 - 12 = 168 \text{ mm}^{\text{DD}}$$



Using the larger moment from case 1b

$$\frac{m}{bd^2 \times f_{cu}} = \frac{25.98 \times 10^6}{10^3 \times 168^2 \times 40} = 0.023 \quad \therefore z = 0.95d$$

$$A_{s \text{ prov}} = \frac{25.98}{0.95 \times 0.168 \times 0.438} = 371.6 \text{ mm}^2 / \text{m}$$

Try T12 @ 300 cc (377 mm<sup>2</sup>/m)

Deflection<sup>EE</sup>

Applying Cl. 3.4.6.5 as before:

$$\beta_b = 1.1; \quad A_{s \text{ req}} = 371.6; \quad A_{s \text{ prov}} = 377; \quad d = 168;$$

$$m = 25.98 \quad L = 5.5 \quad \therefore f_s = 274 \text{ and } k_1 = 1.476$$

$$\text{i.e.} \quad \frac{L}{D} \text{ required} = 26 \times 1.476 = 38.37$$

$$\frac{L}{D} \text{ provided} = \frac{5500}{168} = 32.74 = 32.74$$

As  $32.74 < 38.37$  O.K.

Check for corner levers

$$\text{as } \frac{377}{371.6} = 1.014, \text{ this is only a 1.4\% increase.}$$

The recommended increase to allow for corner levers is 10%, i.e.  $371.6 \times 1.1 = 409 \text{ mm}^2/\text{m}$  should be used. The nearest practical area is  $452 \text{ mm}^2/\text{m}$ , giving T12 @ 250 cc. So this is what should be provided.

T12 @ 250 cc bw B and over supports

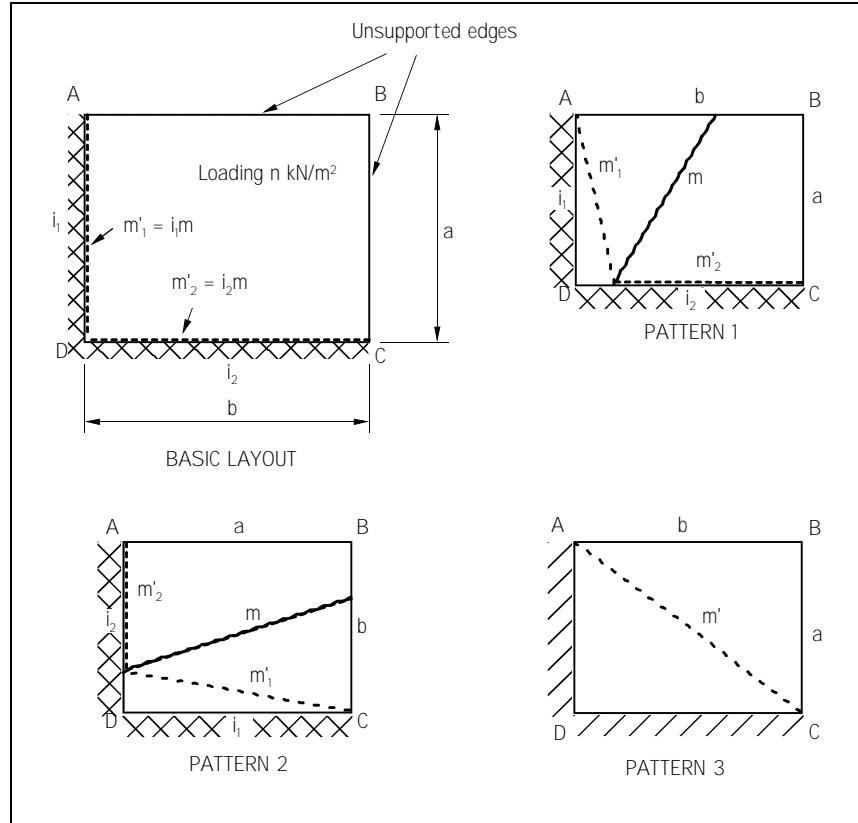
<sup>DD</sup> Wherever there is two-way action and both layers of reinforcement cross the yield line, it is usual to use average effective depths.

<sup>EE</sup> **Deflection:** Although there was no need to increase the reinforcement quantities in order to comply with the span/depth deflection criterion the increase was needed to allow for the more critical pattern forming that includes corner levers. The comment about deflection to the unsupported edge given in the previous example is also relevant here although the proportions of the slab are more favourable.

### 3.5 Two-way slabs - supports on 2 adjacent sides

As shown in Figure 3.8, a slab supported on two adjacent sides can fail in one of three ways:

- in combined sagging and hogging pattern 1
- in combined sagging and hogging pattern 2, or
- as a cantilever (pattern 3).



**Figure 3.8** Slab supported on 2 adjacent sides

The formulae that are applicable to rectangular slabs supported on two adjacent sides are presented as three cases in Table 3.9:

- Case 1 covers the simply supported case where failure pattern 1 applies. In the formula dimension 'a' must be allocated to the shorter side in order to get the largest value for 'm'. It is also vital to ensure that the corner at 'D' is anchored down. In the simply supported case  $m'_1 = m'_2 = 0$ .
- In Case 2, at least one of the sides must be continuous. It is often not apparent which side should be allocated to 'a' or 'b' in the formulae i.e. whether to apply pattern 1 or pattern 2. In that case, each side should be applied in turn i.e. use both pattern 1 and pattern 2 definitions of 'a' and 'b', to find the most onerous value of 'm'.
- Case 3 considers cantilever failure for both simple and continuous support conditions.

**Table 3.9** Formulae for rectangular slabs supported on 2 adjacent sides

Case	Description	Pattern	Formulae
1	Simple supports: $i_1 = i_2 = 0$ $a < b$	1	$m = \frac{n \times a \times b}{4 + 1.5 \frac{a}{b}}$
2	Continuous supports (or one continuous and one simple support): $i_1$ and/or $i_2 \neq 0$	1 or 2*	$b_r = \frac{b}{\sqrt{1+i_1}}$ $m = \frac{n \times a \times b_r}{1.5 + 3 \frac{a}{b_r} + i_2 \left( 1 + \frac{2b_r}{a} \right)}$
3	Cantilever failure (continuous or simple supports)	3	$m' = \frac{n \times a \times b}{6 \left( \frac{a}{b} + \frac{b}{a} \right)}$

Assuming isotropic reinforcement.

\* Check mode of failure by alternating dimensions a and b.

Where

- m is the ultimate moment along the yield line [kNm/m]
- n is the ultimate load per unit area [kN/m<sup>2</sup>]
- a, b are the dimensions of slab [m]
- $b_r$  is the dimension of reduced side b [m]
- $i_1, i_2$  are the ratios of support to midspan moments – the values of which are chosen by the designer
- $m'_1, m'_2$  are the support moments - the values of which are chosen by the designer [kNm/m]
- $m'$  is the ultimate negative moment (across the diagonal)

The magnitude of the holding down force at the corner 'D' to prevent uplift is

$$H = 2m \sqrt{1+i_1} \sqrt{1+i_2} \text{ [kN]}$$

### Example 3G

#### Two-way spanning balcony slab using formulae (supported on 2 adjacent sides)

Analyse and design a simply supported balcony slab  $2.0 \times 1.5$  m supported on brick walls on two adjacent sides. The slab is 200 mm thick. The total ultimate load is  $15 \text{ kN/m}^2$ . Concrete C30 cover 40 mm T&B. The slab is held down against uplift at corner D

Design procedure	
Layout	<p>Balcony slab <math>n = 15 \text{ kN/m}^2</math></p> <p>Isotropic reinforcement</p>
Analysis	<p>Sagging, from Table 3.9 case 1 (<math>a &lt; b</math>)</p> $m = \frac{n \times a \times b}{4 + 1.5 \frac{a}{b}} = \frac{15 \times 1.5 \times 2}{4 + 1.5 \times \frac{1.5}{2}}$ <p><math>m = 8.78 \text{ kNm/m}</math></p> <p>Hogging, cantilever, case 3</p> $m' = \frac{n \times a \times b}{6 \left( \frac{a}{b} + \frac{b}{a} \right)} = \frac{15 \times 1.5 \times 2}{6 \left( \frac{1.5}{2} + \frac{2}{1.5} \right)}$ <p><math>= 3.6 \text{ kNm/m}</math></p>
Design	<p><math>d_{ave} = 200 - 40 - 12 = 148</math></p> $A_{s_{req}} = \frac{8.78}{0.95 \times 0.148 \times 0.438} = 143 \text{ mm}^2/\text{m}^{FF}$ <p>Check for min. of 0.13%: <math>0.13 \times \frac{1000 \times 200}{100} = 260</math></p> <p>As <math>260 \text{ mm}^2/\text{m} \gg 143 \text{ mm}^2/\text{m}</math> there is no need to apply the 10% rule</p> <p><u>Provide T12 @ 300 T&amp;B throughout (377 mm<sup>2</sup>/m)</u></p>

<sup>FF</sup> By inspection  $z = 0.95 d$



Deflection<sup>GG</sup>

Maximum deflection will occur at Corner B but only an elastic finite element analysis could establish the actual deflection.

Span-to-depth ratio checks appear to be inappropriate.

However, Johansen [6] gives guidance on determining the amount of the deflection. The formula he applies in this case is:

$$u = \frac{m'L^2}{3EI} = \frac{m'(a^2 + b^2)}{3EI}$$

where

u is the deflection [m]

E is the elastic modulus [kN/m<sup>2</sup>]

I is the inertia [m<sup>4</sup>]

EI is the flexural stiffness [kNm<sup>2</sup>]

The following calculation is intended to show how this formula might be applied to justify the slab design.

Because the corner is anchored (i.e. D), we should always use  $m' = m$ , i.e. in this case  $m = 8.78$  kNm/m. To get service load moment, assume:

$$m_{serv} = \frac{8.78}{1.5} \approx 5.85 \text{ kNm/m}$$

$$E, \text{ long term modulus, say: } \frac{26000}{3} = 8667 \text{ N/mm}^2$$

I, cracked inertia, say:

$$\frac{0.8 \times 148^3 \times 1}{12} = 216,000 \text{ mm}^4/\text{mm}$$

i.e. deflection u mm:

$$u = \frac{5.85 \times (1.5^2 + 2^2) \times 10^9}{3 \times 8667 \times 216000} = 6.5 \text{ mm}$$

Johansen recommends:

$$u \leq \frac{2L}{500} = \frac{\sqrt{1500^2 + 2000^2}}{250} = 10 \text{ mm}$$

As  $6.5 < 10$ , the slab would appear O.K.

<sup>GG</sup> In slabs of this nature, ultimate strength is rarely going to be the decisive factor, as the need to control deflections will usually be more important. Johansen [6] does give some guidance for obtaining approximate values for deflections based on the results obtained from Yield Line Analysis. See the Appendix.

## 3.6 Flat slabs (on a rectangular grid of columns)

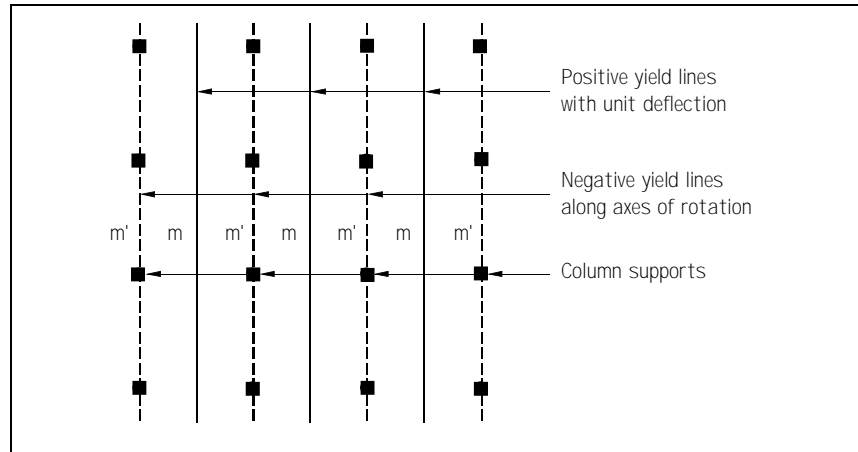
Flat slabs are very straightforward to analyse and design using Yield Line methods.

Flat slabs on a rectangular grid of columns are essentially one-way continuous slabs in two directions and as such are analysed and designed separately in both directions. The most likely mode of failure is the folded plate mechanism where the plates run in either direction. The other possible collapse mode consists of inverted conical failure patterns. The design method and formulae for the inverted conical failure are described below and illustrated in Examples 4A, 4B and 4C.

Notwithstanding the need to check the folding plate failures, flat slabs supported on an irregular grid of columns are most easily dealt with using the Work Method of analysis; the reader is directed to Example 4D.

### 3.6.1 Modes of failure

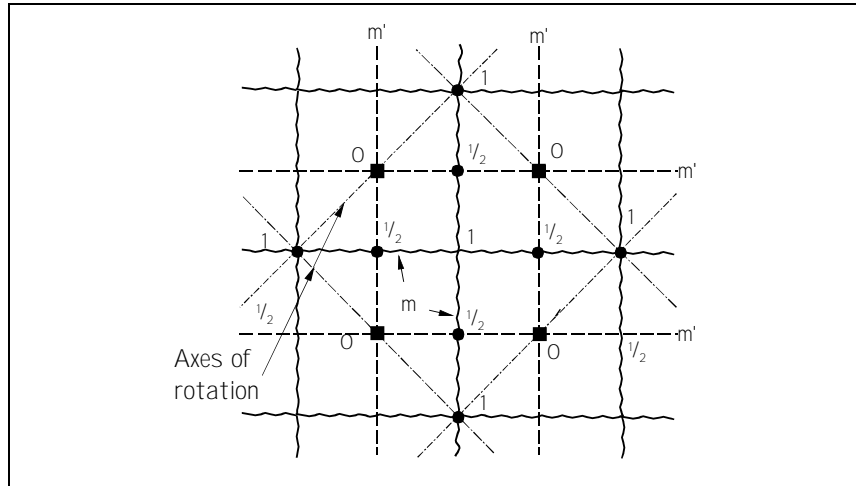
The collapse modes associated with flat slabs on a rectangular grid of columns are shown in Figures 3.9, 3.10 and 3.11



**Figure 3.9** Flat slabs: folded plate collapse mode

*A similar collapse mode, at right angles to the one shown should also be considered*

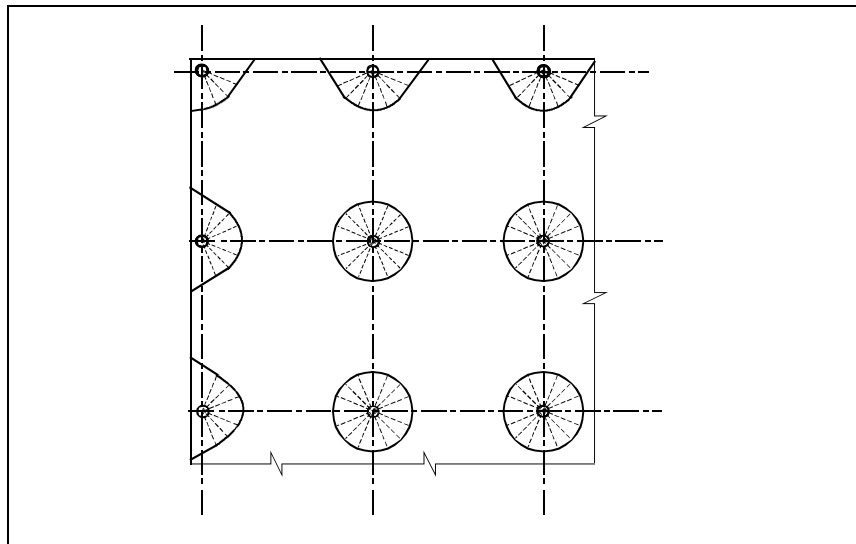
In Figure 3.9 the fracture line pattern consists of parallel positive and negative moment lines with the negative yield line forming along the axis of rotation passing over a line of columns. This forms a folded plate type of collapse mode with maximum deflection taken as unity occurring along the positive yield line. A corresponding pattern could take place at right angles.



**Figure 3.10** Flat slabs: combined folded plate collapse mode

*The assumed deflection at the column supports is 0, at midway between columns, the assumed deflection is  $\frac{1}{2}$  and in the middle of the bay, 1. This mechanism is rarely investigated as there is no change in the collapse load compared to the mechanism shown in Figure 3.9.*

Figure 3.10 shows how these folded plate collapse modes could develop simultaneously in both directions. However, as there is no change in the collapse load, this mechanism is rarely investigated. The axis of rotation for this combined mode passes over the columns. The maximum deflection (of unity) occurs at the centre point in the bay and one half of the maximum deflection occurs at mid-point between columns along the negative yield lines. The fracture lines have been shown schematically on column centre lines but in reality these will form along column faces (because the yield lines must be straight).



**Figure 3.11** Flat slabs: conical collapse modes (with isotropic reinforcement)

*See Tables 3.10 and 3.11 for formulae for internal and perimeter supports respectively.*

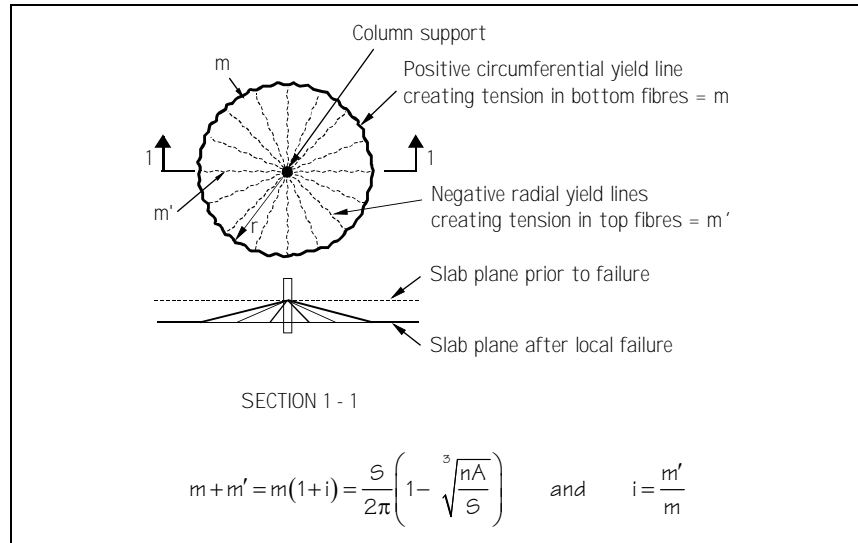
*NB Not to be confused with punching shear failures.*

Figure 3.11 shows the other possible collapse mode consisting of inverted conical failure patterns occurring over each column. Around each column negative radial yield lines emanate from the centre and a positive circumferential yield line forms at the bottom of the cone shaped surface. This collapse mode requires that the remaining slab, the peculiarly shaped central rigid portion of the slab, drops down vertically. This displacement is given the value of unity. The positive circumferential yield line is circular for isotropic reinforcement and elliptical for orthotropic reinforcement with the larger dimension parallel with the direction of the stronger reinforcement

The formulae for local failure patterns are shown in Tables 3.10 and 3.11. With concentration of top reinforcement at supports, as recommended in this publication, this mode of failure will generally not occur.

A separate check for punching shear is required.

**Table 3.10** Flat slabs: formulae for local failure pattern at internal column support (in slabs with isotropic reinforcement)



Where

- m is the positive ultimate moment [kNm/m]
- m' is the negative ultimate moment [kNm/m]
- NB  $m' \leq 3m$  otherwise formula invalid
- n is the ultimate uniformly distributed load [kN/m<sup>2</sup>]
- A is the area of column cross-section [m<sup>2</sup>]
- S is the ultimate load transferred to column from the slab tributary area [kN]

**Note:** S may be equated to  $V_t$ , the design shear transferred to column as defined in BS 8110, clauses 3.7. Notwithstanding BS 8110, Cl 3.8.2.3, it is customary to allow for elastic reactions in calculating this load.

**Table 3.11** Flat slabs: formulae for local failure pattern at perimeter columns (in slabs with isotropic reinforcement)

General case	$\omega m + (2 + \omega - \pi)m' = m \{ \omega(1+i) - 1.14i \} = S \left( 1 - \sqrt[3]{\frac{nA}{S}} \right)$
Edge	<p>For <math>m' = m</math> i.e. <math>i = 1</math> and <math>\omega = 180^\circ = \pi</math></p> $5.14m = S \left( 1 - \sqrt[3]{\frac{nA}{S}} \right)$
Corner (extrnl)	<p>For <math>m' = m</math> i.e. <math>i = 1</math> and <math>\omega = 90^\circ = \pi/2</math></p> $2m = S \left( 1 - \sqrt[3]{\frac{nA}{S}} \right)$

Where

- $m$  is the positive ultimate moment [kNm/m]
- $m'$  is the negative ultimate moment [kNm/m]
- NB  $m' \leq m$  otherwise formula invalid
- $\omega$  is the angle described by edges of slab [rads]
- NB  $2\pi > \omega \geq \pi/3$  (or  $360^\circ > \omega \geq 60^\circ$ ) - otherwise formula is invalid.
- ( $\pi = 3.142$  [rads])
- $n$  is the ultimate uniformly distributed load [kN/m<sup>2</sup>]
- $A$  is the area of column cross-section [m<sup>2</sup>]
- $S$  is the ultimate load transferred to column from the slab tributary area [kN]

### The extent of local failure patterns

For the patterns depicted in Tables 3.10 and 3.11, the radius of the positive circumferential yield line (from the centre of the column) may be calculated from:

$$r = c \times \sqrt[3]{\frac{S}{n \times A}}$$

Where

$S$ ,  $n$  and  $A$  are as above and

$c$  is the radius of an equivalent circular column.

For a rectangular column of dimensions  $a$  and  $b$  the equivalent value of  $c = \sqrt{\frac{a \times b}{\pi}}$

Generally, except where columns are very large,  $r$  works out to be  $< 0.25L$  for internal columns and  $< 0.2L$  for perimeter columns.

The circular yield line is positive and requires bottom reinforcement. This reinforcement needs to be adequately anchored each side of the circular yield line - **hence curtailment of bottom steel near supports is not advised**. Top steel reinforces the top of the slab against radial negative yield lines within the area bounded by the circular yield line. To be effective this top reinforcement therefore needs only nominal anchorage, say 12 diameters, beyond the circular yield line. Limits of 0.25L for internal columns and 0.2L (at right angles to the edge) for perimeter columns are advocated for curtailment of top reinforcement.

Designers may wish to check curtailment using Tables 3.3 and 3.4 to ensure adequate anchorage in all situations. However, with the distribution of top steel advocated and usually employed, this local mode of failure is very rarely an issue that needs considering.

### **Curtailment of reinforcement**

Similar to section 3.1.4, full ultimate loads are considered on each panel to determine the design moments in that panel. For alternate bay loading the same rule for extending top steel by 0.25L into adjoining panels applies. If the designer has any doubt about curtailment then Tables 3.3 and 3.4 can be used if a one-way failure is being investigated. If a two-way failure mode is being considered then these tables no longer apply and a different approach (as say Chapter 10 in ref 16) might be required. However, applying Tables 3.3 and 3.4 in such cases will err on the safe side.

## **3.6.2 Design procedure**

The procedure adopted for the analysis and design of this type of flat slab is to

- Analyse the slab for the straight-line folded plate mode of failure as in Figure 3.9. Use the formulae in Table 3.1 to calculate moments
- Analyse the slab for the straight-line folded plate mode of failure in the orthogonal direction.
- Check against the local modes of failure developing, as illustrated in Figure 3.11. Use the formulae for calculating the moments presented in Tables 3.10 and 3.11.
- Refer to Section 4.1 for notes on how to deal with line loads, deflection, punching shear and reinforcement arrangements, etc.

Usually the formulae in Tables 3.1, 3.10 and 3.11 may be used. However, as illustrated in Example 4B, it may be necessary to resort to the Work Method to deal with irregularities in the slab.

The design procedure for flat slabs is illustrated in Examples 4A to 4D.

# 4.0 How to tackle . . . .

## 4.1 Flat slabs: general

The following three Sections deal with the design of flat slabs using Yield Line Design.

- Section 4.1 deals with general issues.
- Section 4.2 with flat slabs on a regular grid of supports using formulae (as Section 3.6)
- Section 4.3 with slabs on an irregular grid of supports using the Work Method (as Chapter 2).

The methods described apply to slabs in braced frames. Lateral stability is assumed to be provided by some form of vertical bracing between columns or by shear walls somewhere within the confines of the building. Lateral stability, moments induced in columns, column connections and punching shear should be considered separately.

The terms 'regular' and 'irregular' are used to describe the configuration of supports. A regular grid has columns along grid lines in two perpendicular directions forming a rectangular grid of columns. These tend to fail by a folded plate type mechanism in either of the two directions.

All other configurations of supports fall into the irregular category. Here no single type of failure mechanism can be said to predominate. The yield line solution to be found involves investigating one or more of the following possible types of failure:

- 1) A folded plate type mechanism that can form in any direction
- 2) A failure of a panel
  - a) in the form of a polygon that can be inscribed within any number of column or wall supports. The sides of the polygons are formed by axes of rotation which themselves are located at the face of or tangential to the supports.
  - b) around the perimeter where yield lines may bisect the free edge
  - c) as a cantilever type failure
- 3) Local failure mechanisms over supports

Few slabs are completely regular: the designer must be aware of all the possible failure modes that can occur and investigate those he or she considers could be critical.

Flat slabs may either be solid or of waffle construction. They are supported directly on columns with no downstand beams. For the purpose of flexural design of the slab, column connections to the slab are considered as being theoretically pinned so that no moment transfer is taken into account.

Although punching shear design is not intended to be part of this publication, Yield Line principles can be used as justification to concentrate top steel over column heads, thereby greatly enhancing the shear resistance in the vicinity of columns.

Some general principles are discussed below.

### 4.1.1 Perimeter loads

A simple and conservative way of allowing for perimeter cladding loads is to incorporate this line load into an equivalent uniformly distributed load over a chosen width of slab and consider the overall straight line failure patterns.

Based upon elastic principles, BS 8110 Clause 3.5.2.2 spreads the line load over a width of 0.3 x span. However with Yield Line Design, we should consider the global straight yield line failure mechanism for the combined load extending over the whole bay. As a matter of engineering judgement and bearing serviceability requirements in mind, the designer can err on the safe side by dissipating the additional uniformly distributed load over a reduced length of yield line rather than over its whole length. A reasonable compromise would be to spread the total load over a length of yield lines equal to 0.6 of the span of the slab and assess this width of slab independently of the rest of the slab.

This method is conservative as it ignores the two-way action that a local failure pattern, instigated by a line load, would induce. A comprehensive treatise of this type of local failure is given in chapter 1.4 of Johansen's book [6].

### 4.1.2 Deflection and cracking

As far as deflections of flat slabs are concerned it can be said that no real consensus exists on how to establish actual deflections in flat slabs with any great accuracy [8].

Many different procedures exist. Most are very complicated as they require much detailed information that may not be readily to hand or can only be assessed quite arbitrarily. There is, nevertheless, a need to obtain some guidance for choosing a suitable depth of slab without resorting to these complicated methods.

In the vast majority of cases, span-to-depth ratio methods are regarded as being perfectly adequate for checking deflection. Thus for checking flat slabs the recommended procedure is to adhere to the recommendation of BS 8110: Part 1:1997 Clause 3.4.6 for span/depth ratios modified by 0.9 as specified in Clause 3.7.8. Whilst it is a requirement to check the more critical direction, both directions are usually checked. EC2 has specific rules for checking deflection using span-to-depth ratios.

In order to ensure that cracks will not be excessive, Clause 3.7.9 states that the reinforcement spacing rules of Clause 3.12.11.2.7 should be adhered to.

### 4.1.3 Concentrating top reinforcement

In designing top steel to Yield Line principles, the total bay moment is accommodated irrespective of whether the reinforcement is distributed over the whole bay or concentrated over only part of it.

Yield Line Design, therefore, allows designers to choose, if they wish, other arrangements of reinforcement than those dictated by BS 8110 Clause 3.7.2.10 and Table 3.18. The advantages of concentrating it in the vicinity of the column is in enhancing the shear resistance of the slab and that the reinforcement is better placed at column heads to deal with the peaking of the moments at service loads. Table 4.1 gives commonly used concentrations of top reinforcement.

**Table 4.1** Common concentrations of top reinforcement over columns when using Yield Line Design

Location of column	Reinforcement concentrated in area of dimensions		
	x (or y)		y (or x)
Internal	0.5 L	x	0.5 L
Edge	0.5 L	x	(0.2 L + E.D.)
Corner	(0.2 L + E.D.)	x	(0.2 L + E.D.)

Where E.D. = edge distance, centreline of column to edge of slab  
L = span



For resistance to local conical and punching shear failure, top reinforcement is best concentrated around the column. The designer may, if he or she wishes, keep to the code recommendation of dividing the total negative moment in the proportions 75% and 25% between column strips and middle strips respectively.

This arrangement would be appropriate if there were a requirement to restrict cracking to a minimum for, say, a power floated finish with a high specification. There would then be a strong case for having top steel throughout.

Omitting top reinforcement completely between concentrations over column heads can lead to some incidental cracking in these areas. This cracking is not detrimental to the performance of the structure and if in a non-aggressive internal environment with a finish over the top will very seldom cause a problem. The designer may of course choose to place nominal anti-crack mesh in the top of, effectively, the middle strip at supports

Clause 3.7.3.1 of BS 8110 recommends placing 2/3rds of the column strip top reinforcement at supports in the middle 1/2 of the column strip width. This step is unnecessary with Yield Line Design. However, it is interesting to note that adopting the concentration of reinforcement advocated for Yield Line Design leads to the same concentration of reinforcement local to the column (assuming the same amount of reinforcement is required by the two methods), viz:

BS 8110 advice:	2/3 of 75% in L/4	≡ 200% per unit length
Yield Line	100% in L/2	≡ 200% per unit length

While these layouts may differ from the elastic distributions advocated in BS 8110, Gilbert [10] reported that deflection in flat slabs is not significantly affected by varying the amounts of reinforcement between middle and column strips.

#### 4.1.4 Curtailment of top reinforcement

In general the curtailment lengths should be checked using the formulae in Tables 3.3 and 3.4. The procedure is described in the last part of Example 3A.

In Yield Line Design, detailing is governed solely by the configuration of the crack patterns that can form and not by conventional rules used in association with Elastic Design (e.g. Figures 3.24 and 3.25 in BS 8110). Ignoring the tensile strength of concrete, full curtailment of bars results in a yield line moment capacity of zero. So once crack patterns are established, the designer has to ensure that curtailing bars does not produce another failure pattern that would result in a lower collapse load. This may mean that if first principles were used to establish the crack pattern without a maximisation process, the designer has to allow for a more onerous location of the yield line. At working loads there may be areas of the slab in tension. The designer can decide either to accept that these areas might crack, or he/she may increase the length of the reinforcement to take care of them.

For the general case for flat slabs, when the

- spans are approximately equal
- loads are predominately uniformly distributed loads
- design has been carried out using the single load case of maximum design load on all spans (see BS 8110 Clause 3.5.2.3)

Then 100% top steel may generally be curtailed at 0.25 x span from the centreline of internal columns and 100% top steel may generally be curtailed at a distance of 0.20 x span, at right angles to the edge, from the centreline of perimeter columns.

### 4.1.5 Bottom reinforcement layout and curtailment

One of the main advantages of using Yield Line Design for flat slabs is that bottom reinforcement may be placed at regular centres across whole bays, generally without curtailment.

In Yield Line Design, curtailment of bottom reinforcement is best avoided because it is usual to assume a constant moment along the whole length of the yield lines. This is especially true for those yield lines that extend into corners of two-way slabs supported on line supports. This does not mean that bars cannot be curtailed away from the yield lines but it may then be necessary to check whether a yield line pattern giving a lower overall load capacity can develop along the line where the reinforcement is reduced. This can be investigated by either the Work Method or the Equilibrium Method of analysis. Jones gives guidance on this topic [16].

In Yield Line Design, the checks involving the localised failure modes around column supports use the full moment of resistance of the bottom reinforcement,  $m$ , within the areas of the local failure patterns. It is therefore advisable not to carry out any curtailment of bottom bars in these areas.

Conventional detailing practice following the (elastic) bending moment envelope leads to inefficiencies in production due to:

- Different length bars increase the number of bar marks and impose a strict discipline on their placing.
- Staggering bars of the same length also slows down the laying process.
- Changing bar diameters and their spacing to fit as closely as possible to the moment will also effect the time needed to place the bars. Obviously, conventionally designed slabs can be rationalised, but this leads to higher overall reinforcement densities.
- Complex reinforcement layouts also require more checking and offer very little flexibility.

All these points incur increased labour costs and slow down progress on site.

For Yield Line designs it is recommended that bottom steel is not curtailed. This leads to a reduced number of bar marks, greater efficiency and buildability on site.

### 4.1.6 Perimeter details

Local flexural failure modes are rarely critical for interior columns. However, reinforcement over internal columns is usually concentrated over a certain distance either side of the column support to enhance the punching shear resistance. This concentration of reinforcement is also used in the layout of reinforcement at perimeter columns where pinned supports are assumed in the design. The local failure modes used for establishing the minimum amount of this reinforcement, as given in Table 3.11, is best carried out for  $m = m'$ . It is then imperative to ensure that there is at least this amount of reinforcement top and bottom each way for a distance of  $0.2 \times \text{span}$  from the centre line of support at right angles to the edge of slab and  $0.25 \times \text{span}$  from the centre line of support in each direction parallel with the edge of slab.

At corner columns too, it is best to proceed with the assumption that  $m = m'$  and to provide 'U' bars at right angles to cater for this moment projecting as before for a distance of  $0.2 \times \text{span}$  from the centre of the column at right angles to the edge of slab. Corners with an angle of less than  $90^\circ$  should be avoided as they are difficult to reinforce efficiently and design against punching shear failure is then likely to become the governing factor.

Around the perimeter between the concentrations of reinforcement at the columns it is recommended to provide a concentration of reinforcement equivalent to a minimum of 50% of end span bottom reinforcement in the form of 'U'-bars with the top leg extending from the edge a distance of  $0.2 \times \text{span}$  from the centreline of support and the bottom leg having a tension lap with the bottom reinforcement.

Local to the column, the slab should also be capable of accommodating transfer moments,  $M_t$ , subject to  $M_{t_{\max}}$ , derived from considering column design (see below).

#### 4.1.7 Column design

According to BS 8110, Clause 3.8.2.3, the axial load in columns at the ultimate limit state may be calculated assuming that beams and slabs transmitting force to it are simply supported. Whilst the slab is assumed to be supported on pins, it is usual practice to find the column design moments using a single joint sub-frame as BS 8110, Clause 3.2.1.2 or from the local Yield Line pattern as described by Park and Gamble [11]. In the case of unbalanced internal columns the local yield line pattern approach described in Chapter 7.11.3 of Park and Gamble is advocated. The moment transferred to an edge column (and indeed to be resisted locally by the slab) is limited to  $M_{t_{\max}}$  as defined in Clause 3.7.4.2 of BS 8110

According to Eurocode 2 [3] columns should be checked for maximum plastic moments transmitted by connecting members. For flat slabs, this transfer moment should be included in punching shear calculations: for perimeter columns this is the equivalent of  $M_{t_{\max}}$  in BS 8110, Equation 24.

#### 4.1.8 Punching shear

Punching shear should be checked in the conventional manner. The design shear,  $V_t$ , transferred to the column is calculated on the assumption that the maximum design load is applied to all panels adjacent to the column; (assuming that slabs transmitting force to it are simply supported). Section 3.7.6 of BS 8110 details the effective shear force,  $V_{\text{eff}}$ , to be used in punching shear calculations.

Considerable research and testing has been carried out into flexural and punching shear failures and how they relate to each other. It has been shown that, in many cases, it is the bending strength rather than the shear strength of the slab that governs its punching shear resistance. The research carried out in this field by Hans Gesund, OP Dikshit & YP Kaushik [44,45] has resulted in a design procedure that, if adhered to, would ensure that the yield line flexural failure will precede a punching shear failure for a given design ultimate load. This means that it is always possible to safeguard against a punching shear failure prior to a yield line flexural failure. This research was carried out on slabs that were not reinforced for shear. When shear reinforcement is provided, it can aid ductility as well as increasing shear resistance.

In the absence of the Gesund method, it is recommended that the BS 8110 approach is followed when dealing with braced flat slab frames, i.e. the effective punching shear,  $V_{\text{eff}}$ , is a function of the moment transferred to the column. In unbraced flat slab frames where substantial column moments can be induced, a completely different situation would be created requiring a different approach. That is why this type of frame is not considered in this publication.

## 4.2 Flat slabs supported by a rectangular grid of columns

### 4.2.1 Design procedure

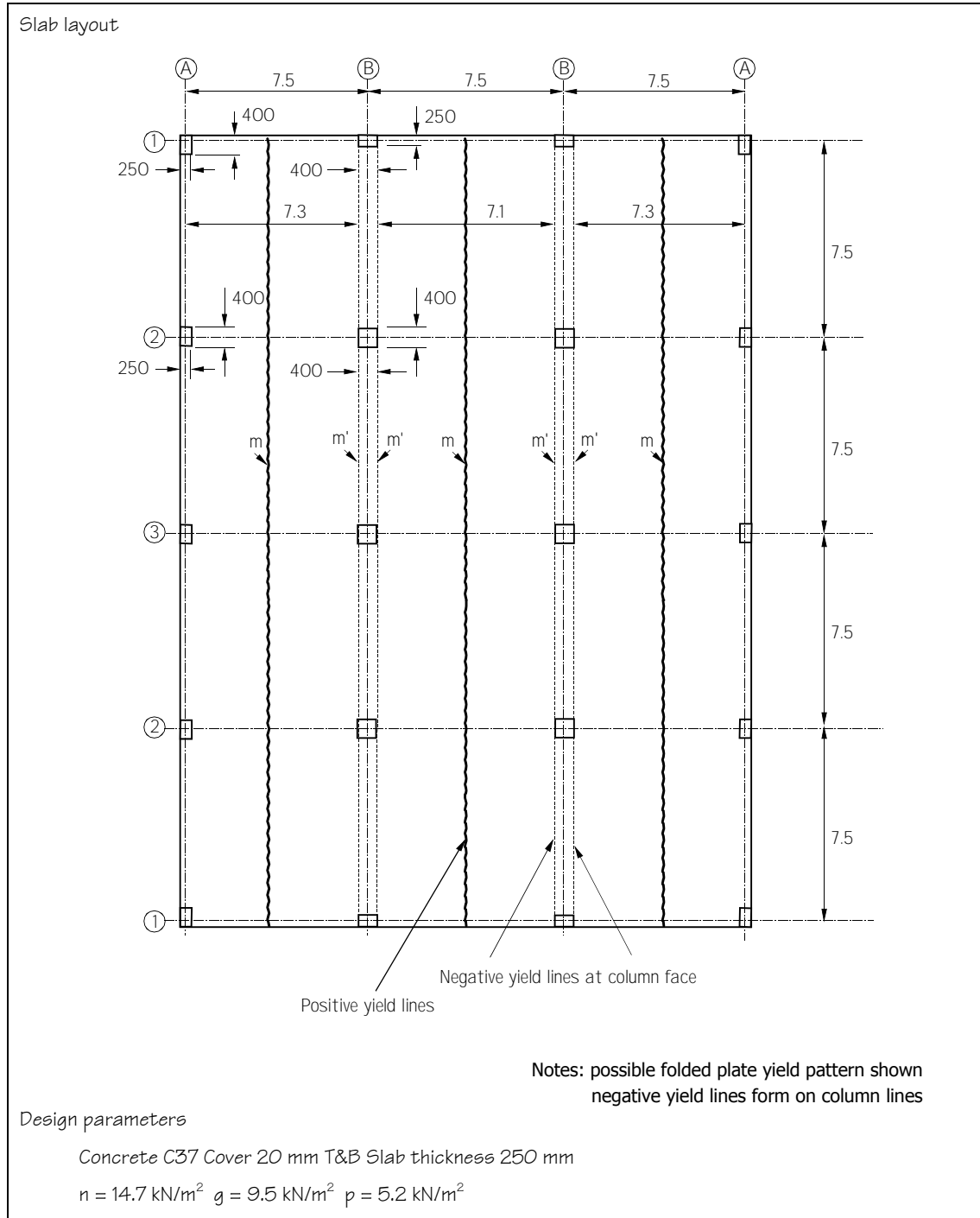
As previously described, the procedure adopted for the analysis and design of this type of flat slab is to:

- Analyse the slab for the straight line folded plate modes of failure in one direction as in Figure 3.9, using the formulae in Table 3.1 to calculate moments.
- Analyse the slab for the straight line folded plate modes of failure in the orthogonal direction.
- Check for local modes of failure. Refer to the formulae described in Tables 3.10 and 3.11 to calculate the moments.

This process is illustrated by Examples 4A, 4B and 4C. Example 4B shows how the Work Method may be used in conjunction with formulae to deal with irregularities.

**Example 4A****Flat slab using formulae**

Analyse and design the 250 mm thick flat slab in 7.5 x 7.5 bays shown below. The ultimate load is  $14.7 \text{ kN/m}^2$  of which ultimate dead load is  $9.5 \text{ kN/m}^2$  and ultimate live load  $5.2 \text{ kN/m}^2$ . Concrete is C37 and cover 20 mm T&B.



END BAY

Analysis:

From Table 3.1 Case 2:

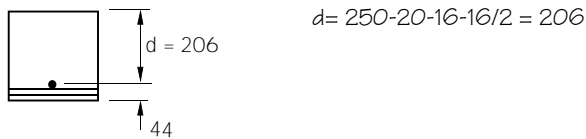
$$m = \frac{nL^2}{2(1 + \sqrt{1 + i_2})^2} \quad L = 7.3 \quad i_2 = 1^{HH}$$

$$m = 14.7 \times 7.322 / 11.66 = \underline{67.15 \text{ kNm/m}}$$

$$m' = i_2 m = \underline{67.15 \text{ kNm/m}}$$

Design of bottom reinforcement

As the spans are the same in both directions, consider reinforcement in the more onerous design condition. (Layering of reinforcement will however stay constant, see Figure 4.1.)



$$\text{Lever arm: } \frac{67.15 \times 10^6}{10^3 \times 206^2 \times 37} = 0.043 \quad \therefore z = 0.95d$$

$$A_{\text{req}} = \frac{67.15}{0.95 \times 0.206 \times 0.438} = 783 \text{ mm}^2/\text{m}$$

To satisfy deflection criteria try T16 @ 175 (1149 mm<sup>2</sup>/m)

Deflection

Check span / effective depth ratio to Cl. 3.4.6 of BS8110.

$$\text{Assume } \beta_b = 1.1, \quad f_s = 2/3 \times 460 \times 786 / 1149 / 1.10 = 190.7 \text{ N/mm}^2$$

$$\text{Tens mod factor } k_f = 0.55 + (477 - 190.7) / 120 / (0.9 + 1.582) = 1.51$$

$$L/d \text{ allowable}^{II} = 0.9 \times 26 \times 1.51 = 35.33$$

$$L/d \text{ actual} = \frac{7300}{206} = 35.44$$

As 35.33 approx = 35.44 say OK

INTERNAL BAY

Analysis, design & deflection check

From Table 3.1 Case 1:

$$m = \frac{nL^2}{2(\sqrt{1 + i_1} + \sqrt{1 + i_2})^2}, \quad L = 7.1, \quad i_1 = i_2 = 1, \quad m = \frac{14.7 \times 7.1^2}{16} = 46.31 \text{ kNm/m}$$

$$A_{\text{req}} = \frac{46.31}{0.95 \times 0.206 \times 0.438} = 540 \text{ mm}^2/\text{m}$$

Provide T16 @ 300 cc B (670 mm<sup>2</sup>/m)

<sup>HH</sup> The ratio of support to mid span moments has been chosen to equal unity. This is generally satisfactory for flat slabs unless there is a significant difference in the length of adjacent spans.

<sup>II</sup> For flat slabs BS 8110 Clause 3.7.8 specifies a factor of 0.9 to be applied.

Check deflection:

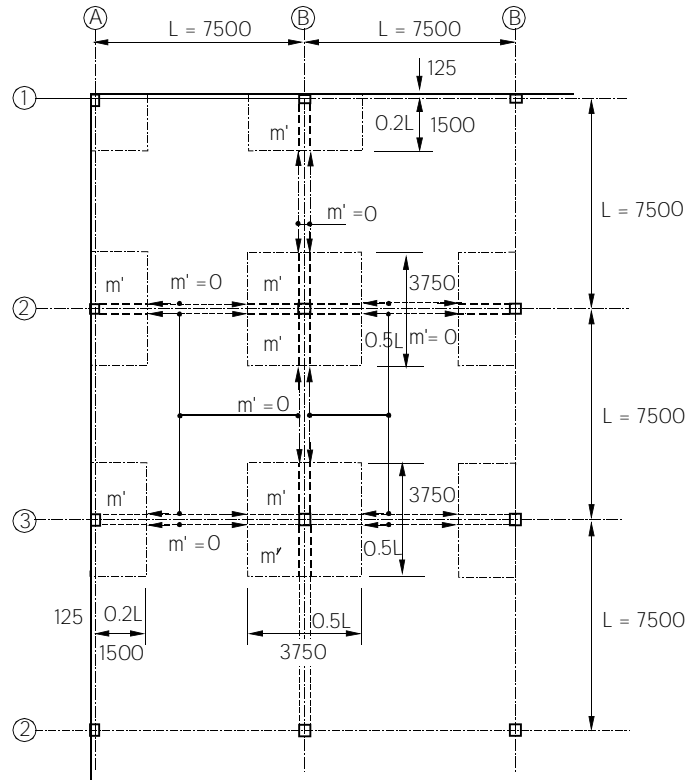
Assume  $\beta_b = 1.2$ ,  $f_s = 206$ ,  $M_u/bd^2 = 1.09$ ,  $\therefore k_1 = 1.68$

$$\frac{L}{d} \text{ allowable} = 0.9 \times 26 \times 1.68 = 39.31$$

$$\frac{L}{d} \text{ actual} = 7100/206 = 34.47$$

As  $34.5 < 39.3$  OK

Proposed distribution of top of reinforcement<sup>JJ</sup>:



Design of top reinforcement perpendicular and along grids 2 and B:

Consider one-and-a-half bays of negative (hogging) moment being resisted over the edge and penultimate column.

Total negative movement along these lines:

$$67.15 \text{ kNm/m} \times (0.125 + 7.5 + 3.75) = 763.83 \text{ kNm}$$

Concentrating negative moment at column heads:

$$m' = \frac{763.83}{(1.625 + 3.75)} = 142.1 \text{ kNm/m}$$

<sup>JJ</sup> Here, in line with one possible procedure described in section 4.1.3 for the distribution of negative moments, the top reinforcement is concentrated:

- at internal columns over a square area of  $0.5 L \times 0.5 L$ ,
- at edge columns over an area of  $0.5 L \times (0.2 L + \text{edge distance, E.D. (edge distance)})$  and
- at corner columns over an area of  $(0.2 L + \text{E.D.}) \times (0.2 L + \text{E.D.})$ .

Between these concentrations of reinforcement it is assumed that  $m' = 0$

$$d = 250 - 20 - 16 - 16/2 = 206$$

$$\text{Lever arm: } \frac{142.1 \times 10^6}{10^3 \times 206^2 \times 37} = 0.09 \quad \therefore z = 0.89d$$

$$A_{s_{req}} = \frac{142.1}{0.89 \times 0.206 \times 0.438} = 1770 \text{ mm}^2/\text{m}$$

Provide T16 @ 100 cc T local edge and penultimate column parallel to edge (2011 mm<sup>2</sup>/m)

See footnote<sup>KK</sup>

Top reinforcement perpendicular and along grid 3

Similarly, total moment along Grid 3:

$$46.3 \times 11.375 = 526.8 \text{ kNm/m}$$

Concentrating negative moment at column heads:

$$m' = \frac{526.8}{(1.625 + 3.75)} = 98 \text{ kNm/m}$$

$$\text{Lever arm: } \frac{98 \times 10^6}{10^3 \times 206^2 \times 37} = 0.062 \quad \therefore z = 0.93d$$

$$A_{s_{req}} = \frac{98}{0.93 \times 0.206 \times 0.438} = 1168 \text{ mm}^2/\text{m}$$

Provide T16 @ 150 cc (1340 mm<sup>2</sup>/m)

Check local failure

Now we need to check the internal columns against local failure as shown in Table 3.10

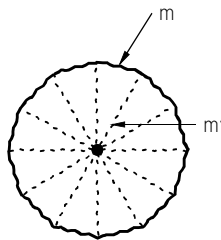
The formula<sup>LL</sup> for this collapse mode is:

$$m + m' = \frac{S}{2\pi} \left( 1 - \sqrt[3]{\frac{nA}{S}} \right)$$

Where:-

A = Area of column cross-section [m<sup>2</sup>]

S = Total ultimate load transferred from slab to column [kN]



Total negative bay moment:	67.15 × 7.5	= 503.6 kNm.
75% at the column would give:	75% × 503.6 / 3.75	= 100.7 kNm/m and
25% adjacent to this	25% × 503.6 / 3.75	= 33.6 kNm/m

These column and middle strips are 3.75 m wide and would require T16 @ 150 cc T each way in column strips and T12 @ 300 cc T together with some distributional reinforcement between in the middle strips. This compares to the T16 @ 100 cc T both ways chosen and specified here which also gives a slightly superior design concrete shear stress.

The 75% : 25% arrangement would be appropriate if there was a requirement for a power floated finish having a high specification for admissible crack widths. There would then be a strong case of providing top steel throughout.

<sup>LL</sup> See Table 3.10



Column B2: check local failure

$$S = ((0.55 \times 7.5) + 3.75)^2 \times 14.7 = 912 \text{ kN}$$

$$A = 0.4 \times 0.4 = 0.16 \text{ m}^2$$

$$\sqrt[3]{\frac{14.7 \times 0.16}{912}} = 0.137: \quad 1 - 0.137 = 0.863$$

$$\text{So } m + m' = \frac{912}{2\pi} \times 0.863$$

But  $m$  is the moment of resistance,  $m_r$ , using the bottom reinforcement.

Average of bottom reinforcement: (NB no curtailment B)

$$\text{One way} \quad \text{T16 @ 175} \quad 1149 \text{ mm}^2/\text{m}$$

$$\text{Other way} \quad \text{T16 @ 300} \quad 670 \text{ mm}^2/\text{m}$$

$$\text{Average} = \frac{1149 + 670}{4} = 910 \text{ mm}^2/\text{m} \text{ at average } d \text{ of say, } 214 \text{ mm}$$

$$m_r = 910 \times 0.95 \times 0.214 \times 0.438 = 81.03 \text{ kNm/m}$$

$$\text{So: } 81.03 + m' = \frac{912}{2\pi} \times 0.863$$

$$m' = 125.3 - 81.03 = 44.27 \text{ kNm/m}$$

but from above  $m'$  at Column B2 has been designed for a moment of 142.1 kNm/m

As  $44.27 < 142.1$  this local mode of failure is not critical

Column B3

$$S = 7.875 \times 7.5 \times 14.7 = 868 \text{ kN}$$

$$\sqrt[3]{\frac{14.7 \times 0.16}{868}} = 0.139: \quad 1 - 0.139 = 0.861$$

$$A_{s_{\text{Baverage}}} = \frac{3 \times 670 + 1149}{4} = 790 \text{ mm}^2/\text{m}$$

$$m_{r_{\text{average}}} = 790 \times 0.95 \times 0.214 \times 0.438 = 70.3 \text{ kNm/m}$$

$$\text{Now } 70.3 + m' = \frac{868}{2\pi} \times 0.861$$

$$\therefore m' = 119 - 70.3 = 48.7 \text{ kNm/m}$$

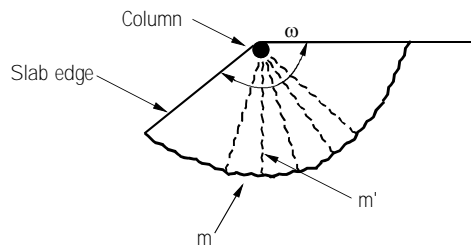
but  $m'$  at Column B3 has been designed for a moment of 98 kNm/m

As  $48.7 < 98$ , this mode of failure will not occur and therefore not critical

Edge and corner columns

The edge and corner columns will be analysed for a local failure occurring. From Table 3.11, the general formula covering this type of failure is:

$$\omega m + (2 + \omega - \pi) m' = S \left( 1 - \sqrt[3]{\frac{nA}{S}} \right)$$



$\omega$  = Angle formed by slab edge  
 $S$  = Column load from slab  
 $A$  = Area of column section

Column A1

$$\omega = 90^\circ = \frac{\pi}{2} \text{ i.e.}$$

$$\omega m + (2 + \omega - \pi)m' = S \left( 1 - \sqrt[3]{\frac{nA}{S}} \right)$$

$$1.57m + 0.43m' = S \left( 1 - \sqrt[3]{\frac{nA}{S}} \right)$$

Choosing<sup>MM</sup>  $m = m'$

$$2m' = S \left( 1 - \sqrt[3]{\frac{nA}{S}} \right)$$

$$S = 3.5 \times 3.5 \times 14.7 = 180 \text{ kN}$$

$$[0.45 \times 7.5 + 0.125 = 3.5]$$

and

$$A = 0.25 \times 0.4 = 0.1 \text{ m}^2$$

$$\sqrt[3]{\frac{14.7 \times 0.1}{180}} = 0.2: \quad 1 - 0.2 = 0.8$$

$$2m' = 180 \times 0.8$$

$$m' = 72 \text{ kNm/m}$$

$$A_{\text{req}} = \frac{72}{0.95 \times 0.214 \times 0.438} = 809 \text{ mm}^2/\text{m}$$

Provide T12 @ 125 (905 mm<sup>2</sup>/m) 'U' bars each way

(each leg  $0.2L + 100^{\text{NN}} = 1600 \text{ mm}$  long)

Column A2

$$\omega = 180^\circ = \pi, \text{ i.e.}$$

$$\omega m + (2 + \omega - \pi)m' = S \left( 1 - \sqrt[3]{\frac{nA}{S}} \right)$$

$$3.14m + 2m' = S \left( 1 - \sqrt[3]{\frac{nA}{S}} \right)$$

<sup>MM</sup> For all edge columns it is good practice to put  $m = m'$  and then to make sure there is at least this amount of reinforcement top and bottom each way. Therefore at corners provide 'U' bars each way for this moment. The slab should also be checked for column transfer moment.

<sup>NN</sup> 100 mm = distance from centerline to edge of column: See also curtailment checks at end of this design.

Assuming  $m = m'$

$$5.14m' = S \left( 1 - \sqrt[3]{\frac{nA}{S}} \right)$$

$$S = 3.5 \times 7.875 \times 14.7 = 405 \text{ kN} \quad [7.5 \times 0.55 + 7.5 \times 0.5 = 7.875]$$

$$\sqrt[3]{\frac{14.7 \times 0.1}{405}} = 0.154 \quad 1 - 0.154 = 0.846$$

$$5.14m' = 405 \times 0.846 \quad \therefore m' = 66.7 \text{ kNm/m} = m$$

$$A_{s, req} = \frac{66.7}{0.95 \times 0.214 \times 0.438} = 749 \text{ mm}^2/\text{m}$$

Provide T12 @ 125 (905 mm<sup>2</sup>/m) 'U' bars at right angles to the edge - as Column A1.

Check adequacy of the bottom reinforcement within this local failure pattern:

$$A_{s, average} = \frac{1.6 \times 1149 + 1.6 \times 670 + 3.75 \times 905}{1.6 + 1.6 + 3.75} = 907 \text{ mm}^2/\text{m}$$

As  $907 > 749$  O.K. Top reinforcement, by inspection, OK.

#### Column A3

Local failure mode same as Column A2 so  $m = m' = 66.7 \text{ kNm/m}$ .

Check that the bottom reinforcement is adequate for the moment from this potential local failure mode.

The bottom bars in direction of numbered grid lines are

T12 @ 125 giving 905 mm<sup>2</sup>/m

$$\text{i.e. } m_r = 905 \times 0.95 \times 0.218 \times 0.438 = 82 \text{ kNm/m}$$

The bottom bars in direction of lettered grid lines are T16 @ 300 giving 670 mm<sup>2</sup>/m

$$\text{i.e. } m_r = 670 \times 0.95 \times 0.206 \times 0.438 = 57.4 \text{ kNm/m}$$

The average resistance moment of the bottom bars passing through the perimeter of the area of the concealed column head i.e. 1600 × 3750 is:

$$\frac{57.4 \times 1.6 \times 2 + 82 \times 3.75}{3.2 + 3.75} = 71 \text{ kNm/m} \quad \text{i.e. as } 71 > 66.7 \text{ O.K.}$$

Top reinforcement, by inspection, OK.

#### Between columns

Around the perimeter between the column head reinforcement (i.e. concealed within the depth of the slab) it is recommended to provide a minimum of 50% of the required end span bottom reinforcement thus: in this instance

$$\frac{783}{2} = 391.5 \text{ mm}^2/\text{m} \quad \text{Provide T12 @ 250 cc 'U' bars (452 mm}^2/\text{m)}$$

Top steel curtailment

In simple slabs, it is customary (see section 3.1.4) to curtail top steel ¼ span from internal supports and approximately 1/5 span from end supports. Nonetheless these curtailments should be checked against local failure patterns by investigating the radius of the circular yield line, as per section 3.6.1.

Internal column B2 :

$$c = \sqrt{\frac{400 \times 400}{\pi}} = 226 \text{ mm} \quad r = 0.226 \times \sqrt[3]{\frac{912}{14.7 \times 0.16}} = 1650 \text{ mm} \quad 12 \times \emptyset = 12 \times 16 = 192 \text{ mm}$$

so from centreline total bar length required is 1650 + 192 = 1842 mm say L/4 = 1875 O.K.

Edge column A2 :

$$c = \sqrt{\frac{250 \times 400}{\pi}} = 178 \text{ mm} \quad r = 0.178 \times \sqrt[3]{\frac{405}{14.7 \times 0.1}} = 1158 \text{ mm} \quad 12 \times \emptyset = 12 \times 12 = 144 \text{ mm}$$

so from centreline total bar length required is 1158 + 144 = 1302 mm say L/5 = 1500 O.K.

Corner column A1 :

$$c \text{ is } 178 \text{ as before} \quad r = 0.178 \times \sqrt[3]{\frac{180}{14.7 \times 0.1}} = 884 \text{ mm}$$

so from centreline total bar length required is 884 + 144 = 1028 mm say L/5 = 1500 O.K.

Punching shear

Punching shear design would be carried out at all column supports in the conventional manner for the following design effective shear loads in accordance with clause 3.7.6 of BS 8110:Part 1: 1997 :

Corner Column A1:

$$V_t = (0.125 + 0.45 \times 7.5)^2 \times 14.7 = 180 \text{ kN} \quad V_{\text{eff}} = 1.4 \times 180 = 252 \text{ kN}$$

Penultimate edge Column A2 :

$$V_t = (0.55 \times 7.5 + 0.5 \times 7.5) \times (0.125 + 0.45 \times 7.5) \times 14.7 = 405 \text{ kN}$$

$$V_{\text{eff}} = 1.25 \times 405 = 506 \text{ kN}$$

Internal edge Column A3 :

$$V_t = 7.5 \times (0.125 + 0.45 \times 7.5) \times 14.7 = 386 \text{ kN}$$

$$V_{\text{eff}} = 1.25 \times 386 = 483 \text{ kN}$$

Penultimate central Column B2 :

$$V_t = (0.55 \times 7.5 + 0.5 \times 7.5)^2 \times 14.7 = 912 \text{ kN}$$

$$V_{\text{eff}} = 1.15 \times 912 = 1049 \text{ kN}$$

Internal central Column B3 :

$$V_t = (0.55 \times 7.5 + 0.5 \times 7.5) \times 7.5 \times 14.7 = 868 \text{ kN}$$

$$V_{\text{eff}} = 1.15 \times 868 = 998 \text{ kN}$$

## Reinforcement summary

End bays	T16 @ 175 B	
Internal bays	T16 @ 300 B	
Penultimate supports	T16 @ 100 T	Extending 1875 either side of penultimate grid for 1625 from edge and for 1875 either side of internal grid
Internal supports	T16 @ 150 T	Extending 1875 either side of internal grid for 1875 either side of internal grid
Corner columns	T12 @ 125 U bars	Extending 1625 from edge for 1625 from edge both ways
Edge columns	T12 @ 125 U bars	Extending 1625 from edge for 1875 either side of grid
Edges	T12 @ 250 U bars	
Punching shear reinforcement	As designed	

For the top and bottom reinforcement layout see Figure 4.1.

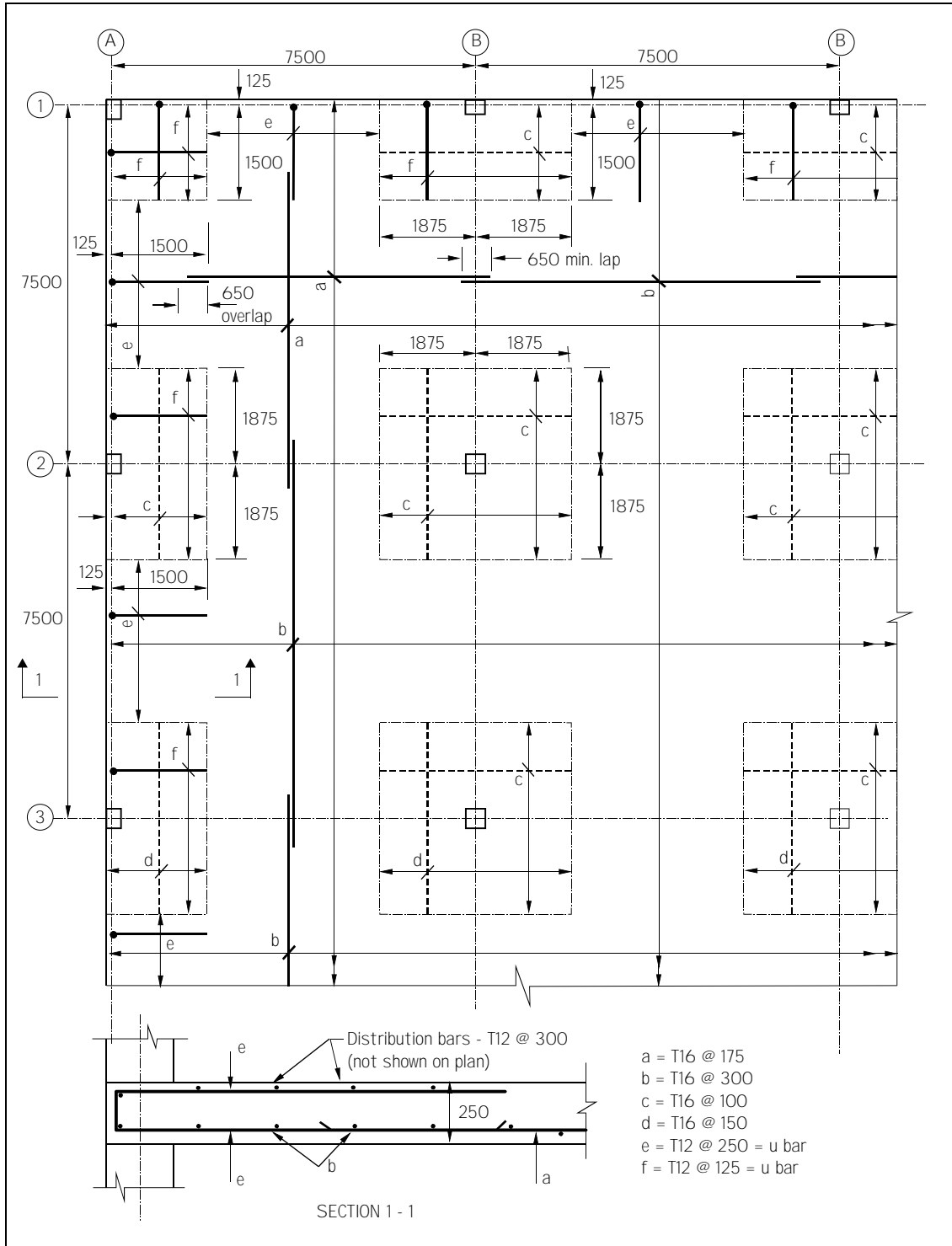
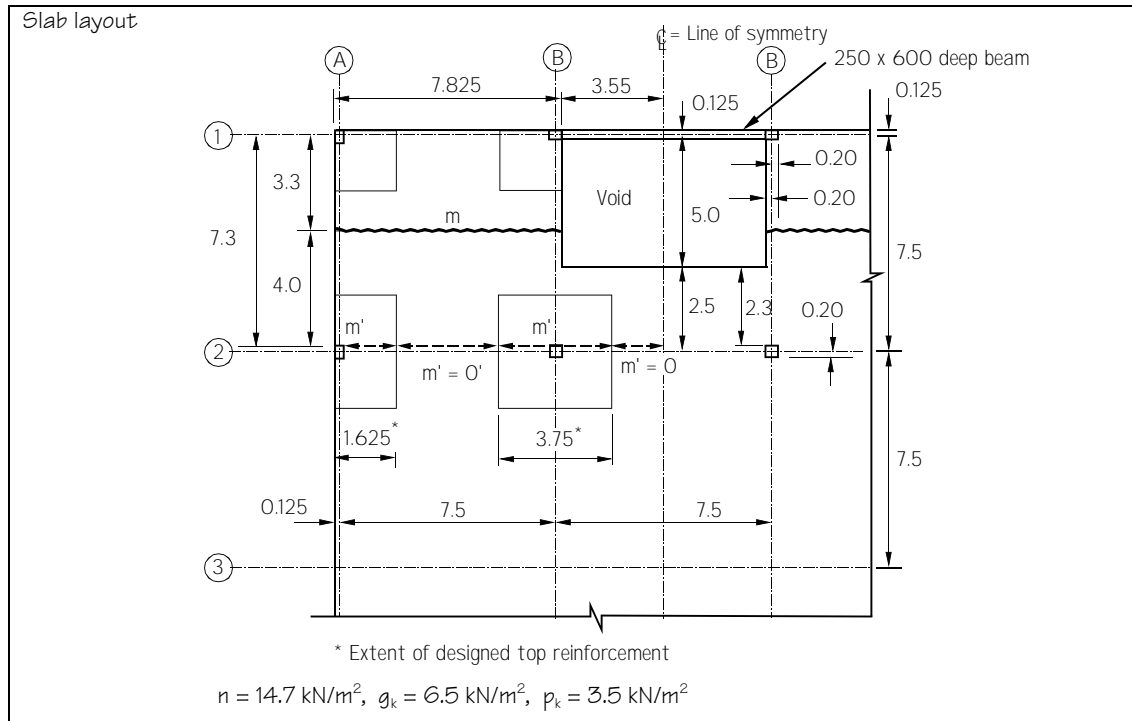


Figure 4.1 Reinforcement layout for flat slab Example 4A

Figure 4.1 shows the distribution of reinforcement. The bars have been placed in alternate layers, which enables the same 'U' bar to be used along each edge of the slab. The whole layout of steel has been designed to give the least number of bar marks, simple and easy to follow steel arrangement and as much repetition as possible. These are the hallmarks of economic construction. From this a transition to prefabricated mat reinforcement would be a simple step to make. There is no curtailment of bottom reinforcement. As the slab and its design complied with the conditions for simple curtailment, the top steel has been curtailed at  $0.25 \times$  span.

**Example 4B****Flat slab (with void) using the Work Method**

Show how the design of Example 4A would be affected by the inclusion of a void in the bays between Grids 1 & 2 in the end of the 250 mm thick flat slab, shown below. Concrete C37, cover 20 mm T & B.

**Methodology**

The recess (or void) renders the slab irregular and as it does not now conform with assumptions inherent in using the formulae, it will be necessary to apply the Work Method to establish  $m$  and  $m'$ .

## 1) Consider slab spanning in direction of lettered grid lines

Applying the work method, considering half of the slab (to the left hand side of the centreline) and choosing  $m = m'$  and yield line 3300 from grid line 1.

E =

$$3.3 \times 7.825 n \times \frac{1}{2} = 12.91n$$

$$4.0 \times 7.825 n \times \frac{1}{2} = 15.65n$$

$$2.3 \times 3.55 n \times \frac{1.15}{4} = 2.35n$$

$$\Sigma = 30.91n$$

D =

$$7.825 m \times \frac{1}{3.3} = 2.37m$$

$$7.825 n \times \frac{1}{4} = 1.96m$$

$$11.375 m' \times \frac{1}{4} = 2.84 m'$$

$$\Sigma = 7.17m \quad \text{NB: } m = m'$$

From  $E = D$ , we get:

$$7.17 \text{ m} = 30.91n$$

$$m = \frac{30.91n}{7.17} = 4.31n = 4.31 \times 14.7 = 63.37 \text{ kNm/m}$$

Applying the 10% rule to allow for onerous location of the yield line:

$$m = 1.10 \times 63.37 = 69.7 \text{ kNm/m}$$

$$\underline{m' = 69.7 \text{ kNm/m}}$$

Design of bottom reinforcement

$$M/bd^2f_{cu} = \frac{69.7 \times 10^6}{10^3 \times 206^2 \times 37} = 0.044 \quad \therefore z = 0.95d$$

$$A_s \text{ req} = 69.7 / (0.95 \times 0.206 \times 0.438) = 813 \text{ mm}^2/\text{m}$$

Try T16 @ 150 cc (1340 mm<sup>2</sup>/m)

The rest of the bottom reinforcement in this direction stays unchanged compared to Example 4A.

Deflection

As before,  $L/d$  for flat slabs Cl. 3.7.8 from BS8110

$$0.9 \times 26 = 23.4$$

$$\beta_B = 1.1^{00} ; f_s = 2 \times 460 \times 813 / (3 \times 1340) \times 1/1.1 = 169$$

$$M/bd^2 = 1.64, \text{ we get } k_1 = 1.50$$

$$L/d \text{ allowed} = 0.9 \times 26 \times 1.56 = 36.5$$

$$L/d \text{ actual} = 7300 / 206 = 35.4$$

$$As \ 36.5 > \underline{35.4 \text{ O.K}}$$

Design of top reinforcement (grid 2)

As we intend to concentrate all the top steel in the vicinity of the column supports, we get:

$$\text{Total moment: } 69.7 \times 11.375 = 793 \text{ kNm/m}$$

$$m' = \frac{793}{(1.625 + 3.75)} = 147.5 \text{ kNm/m}$$

This applies to column head reinforcement at 2A and 2B, in direction of lettered grid lines. Here "column head" refers to reinforcement concentrated within the depth of the slab.

$$M/bd^2f_{cu} = \frac{147.5 \times 10^6}{10^3 \times 222^2 \times 37} = 0.081 \quad \therefore z = 0.90d$$

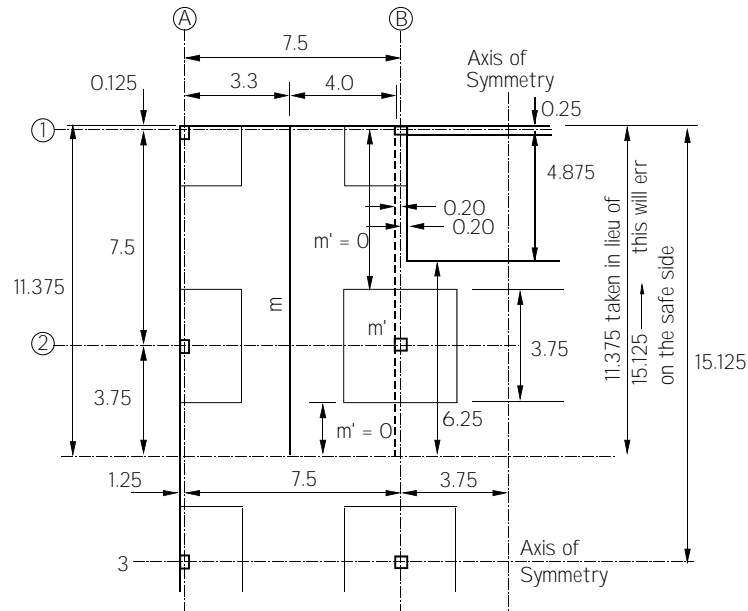
$$A_{s \text{ req}} = \frac{147.5}{0.90 \times 0.222 \times 0.438} = 1685 \text{ mm}^2/\text{m}$$

Provide T16 @ 100 cc (2011 mm<sup>2</sup>/m) top as before)

<sup>00</sup>  $\beta_B$  may generally be assumed to be 1.10. See Appendix for explanation.



2) in direction of numbered grid lines<sup>PP</sup>



Applying the work method and choosing  $m = m'$

E =

$$3.3 \times 11.375n \times \frac{1}{2} = 18.77n$$

$$4.0 \times 11.375 \times \frac{1}{2} = 22.75n$$

$$\Sigma = 41.52n$$

D =

$$11.375m \times \frac{1}{3.3} = 3.45m$$

$$11.375 \times \frac{1}{4} = 2.84m$$

$$6.25m' \times \frac{1}{4} = 1.56m'$$

$$\Sigma = 7.85m \quad \text{NB: } m = m'. \text{ See footnote}^{\text{QQ}}$$

<sup>PP</sup> The analysis is based on considering yield lines in part of the slab. The judgement of considering yield lines up to half way between grids 2 and 3 reflects balancing adequate analysis against saving computational time. Analysis of the whole bay may have resulted in less reinforcement, but would have required greater effort.

It will be noticed that in the diagram there is a yield line shown parallel and close to the adjacent opening. This apparent anomaly is explained by the fact that yield lines are straight and that this part of the yield line is an extension of the more global yield line. A yield line that cuts the opening would be feasible but the associated patterns would be complex and the effort required would be very hard to justify. In any event the designer's discretion can be used and it will be seen later in the calculation that a value of zero has been given to the yield line adjacent to the opening.

The beam bordering the recess is ignored in terms of the design of the slab. However, when considering deflection, it provides some continuity to the slab

<sup>QQ</sup> The length of the negative yield line has been restricted to that length that might be considered as being continuous.

From  $E = D$ , we get:

$$7.85 \text{ m} = 41.52 \text{ n}$$

$$m = 41.52 \times 14.7 / 7.85 = 77.75 \text{ kNm/m}$$

Apply 10% rule and increase

$$\therefore m = m' = 1.1 \times 77.75 = 85.53 \text{ kNm/m}$$

Design of bottom reinforcement

$$M / db^2 f_{cu} = \frac{85.53 \times 10^6}{10^3 \times 222^2 \times 37} = 0.047 \quad \therefore z = 0.94d$$

$$A_{s \text{ reqd}} = \frac{85.53}{0.94 \times 0.222 \times 0.438} = 936 \text{ mm}^2 / \text{m}$$

Try T16 @ 150 cc (1340 mm<sup>2</sup>/m)

Deflection

Although there is continuity in the majority of the slab spanning A to B and in the beam on grid 1, a part of bay A-B, 1-2 might be regarded as being simply supported spanning between A and B. This slab will be partway between simply supported and continuous.

Using judgement assume  $4.875 / 11.375$  (43 %) is simply supported and 57 % continuous.

The basic span / effective depth ratio will then be :

$$= (26 \times 0.57 + 20 \times 0.43) \times 0.9 = 21.1$$

$$\beta_b = 1.0, \quad f_s = 214, \quad M_u / bd^2 = 1.9 \quad \therefore k_1 = 1.38$$

$$L/d \text{ allowed} = 21.1 \times 1.38 = 29.1$$

$$L/d \text{ actual} = 7300 / 222 = 32.9 \quad \text{Not OK}$$

Try T16 @ 150 cc top & bottom : (1340 mm<sup>2</sup>/m)

$$\beta_b = 1.0, \quad f_s = 214, \quad k_1 = 1.38, \quad k_2 = 1.18$$

$$L/d \text{ allowable} = 21.1 \times 1.38 \times 1.18 = 34.36$$

$$L/d \text{ actual} = 7300 / 222 = 32.9 \quad \text{OK}$$

So in span provide T16 @ 150 cc T & B: (1340 mm<sup>2</sup>/m)

The rest of the bottom steel as the steel along Grid 3 stays unchanged.

Design of top reinforcement

$$\text{Total moment: } 85.53 \times 6.25 = 534.56 \text{ kNm/m}$$

$$m' = \frac{534.56}{3.75} = 142.55 \text{ kNm/m}$$

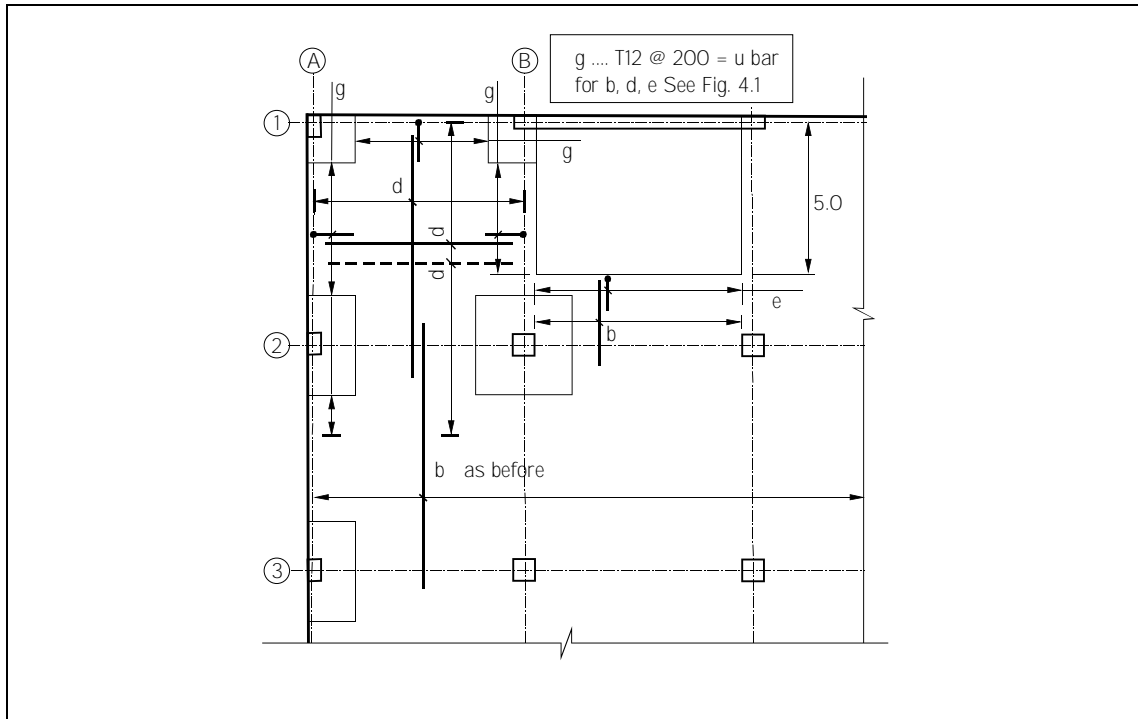
$$M / bd^2 f_{cu} = \frac{142.55 \times 10^6}{10^3 \times 206^2 \times 37} = 0.09 \quad \therefore z = 0.89d$$

$$A_{s \text{ reqd}} = \frac{142.55}{0.89 \times 0.206 \times 0.438} = 1775 \text{ mm}^2 / \text{m}$$

Provide T16 @ 100 cc (2011 mm<sup>2</sup>/m) (no change)

Reinforcement

See Figure 4.2 for the reinforcement change as a result of the recess.



**Figure 4.2** Reinforcement layout with recess

*To be read in conjunction with Figure 4.1. Only reinforcement that has changed due to the addition of the recess is shown.*

*The Work Method of analysis was applied to establish the required reinforcement for the case of the flat slab with a recess. The analysis and design was based on using a similar layout of bars to that used shown in Figure 4.1, which itself was based on analysing the slab as a one-way slab in two directions. Only reinforcement that required to be changed due to the addition of the recess is shown.*

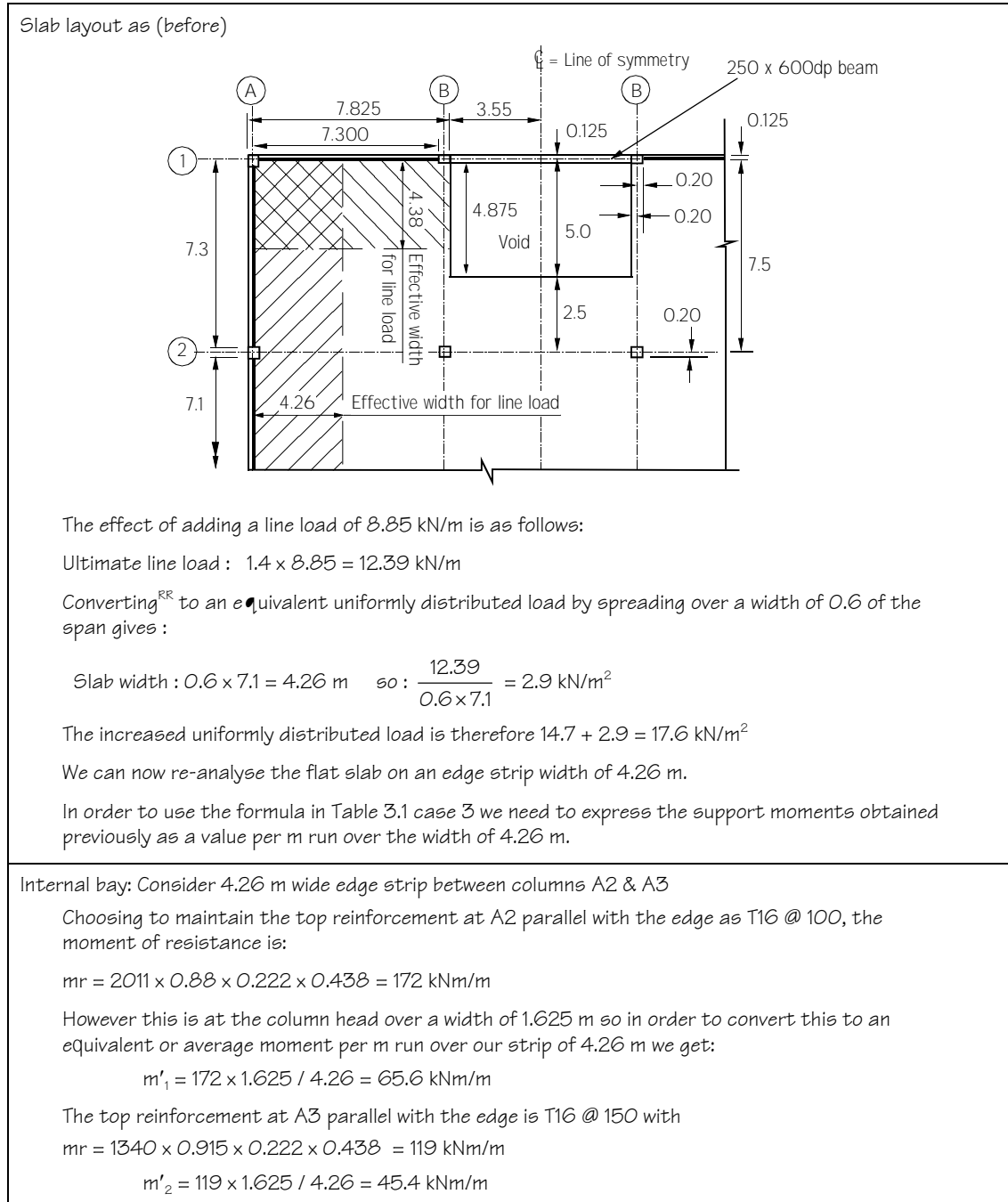
*All top reinforcement in column head areas remains unchanged.*

*For serviceability reasons there was a need to add compression reinforcement in the end bay in one direction for which distribution steel (not shown) would be required.*

## Example 4C

### Flat slab using formulae (with line load)

Investigate the effect that an edge line load of 8.85 kN/m for cladding along grids A and 1 will have on the analysis and design of Example 4B.



<sup>RR</sup> See Section 4.1.1, perimeter loads

Consider as Table 3.1, Case 3:

$$nL^2 = 17.6 \times 7.1^2 = 887 \quad \& \quad m'_1 - m'_2 = 65.6 - 45.4 = 20.2$$

$$m = \frac{nL^2 - 4 \left( m'_1 + m'_2 - \frac{(m'_1 - m'_2)^2}{nL^2} \right)}{8} = \frac{887 - 4 \left( 65.6 + 45.4 - \frac{20.2^2}{887} \right)}{8} = 55.6 \text{ kNm/m}$$

the bottom reinforcement required in the 4.26m wide strip is:

$$A_{\text{req}} = \frac{55.6}{0.95 \times 206 \times 0.438} = 649 \text{ mm}^2/\text{m}$$

Try T16 @ 250 (804 mm<sup>2</sup>/m)

Check deflection:

$$\beta_b = 1.2, \quad f_s = 206, \quad k_1 = 1.57$$

$$L/d \text{ allowed} = 23.4 \times 1.57 = 36.7$$

$$L/d \text{ actual} = 7300 / 206 = 35.4 \text{ OK.}$$

Summary for A2 to A3

Provide T16 @ 250 B over a width of 4.26 m in the bay between grid lines 2 & 3.  
(was T16 @ 300 without edge line load)

Support A2

As discussed above, T16 @ 100T will be used. This equates to  $m'_2 = 65.6$  kNm/m over the 4.26 m strip width

End span A1 to A2.

Consider the 4.26 m wide edge strip between columns A1 & A2. The negative moment at Col. A2 has previously been established,  $m'_2 = 65.6$  kNm/m, and Col. A1 is a simple support. So case 4 of Table 3.1 may be applied to establish the span moment:

$$m = \frac{nL^2 - 4 \left( m'_2 - \frac{(m'_2)^2}{nL^2} \right)}{8}$$

$$nL^2 = 17.6 \times 7.3^2 = 938, \quad m'_2 = 65.6$$

$$m = \frac{938 - 4 \left( 65.6 - \frac{65.6^2}{938} \right)}{8} = 86.7 \text{ kNm/m}$$

The required bottom reinforcement in the 4.26 m wide strip is:

$$A_{\text{req}} = \frac{86.7}{0.935 \times 206 \times 0.438} = 1028 \text{ mm}^2/\text{m}$$

Try T16 @ 100 (2011 mm<sup>2</sup>/m)

Check deflection:

$$\beta_b = 1.1, \quad f_s = 143, \quad k_1 = 1.5$$

$$L/d \text{ allowed} = 23.4 \times 1.5 = 35.1 \quad ; \quad L/d \text{ actual} = 7300 / 206 = 35.4 \text{ OK.}$$

As 35.1 approximately = 35.4 consider OK

Provide T16 @ 100 (2011 mm<sup>2</sup>/m) over a width of 4.26m in the end bay.

Here it can be seen that in order to comply with BS 8110 deflection criteria the area of bottom reinforcement had to be virtually doubled.

Grid 1

Design the slab for the edge line load as being simply supported but when checking for the deflection, take into account the continuity offered by the adjoining beam.<sup>55</sup>

Ultimate line load :  $1.4 \times 8.85 = 12.39$  kN/m

Converting this to an equivalent uniformly distributed load by spreading over a width of 0.6 of the span gives:

$$\text{Slab width: } 0.6 \times 7.3 = 4.38 \text{ m} \quad \text{so: } \frac{12.39}{0.6 \times 7.3} = 2.8 \text{ kN/m}^2$$

The increased uniformly distributed load is therefore  $14.7 + 2.8 = 17.5$  kN/m<sup>2</sup>

Edge strip

The midspan moment is:

$$m = \frac{n \times L^2}{8} = \frac{17.5 \times 7.3^2}{8} = 117 \text{ kNm/m}$$

$$m/bd^2f_{cu} = 117 \times 10^6 / (10^3 \times 222^2 \times 37) = 0.064$$

$$z = 0.92 \times 222 = 204.2$$

$$A_{sreq} = 117 \times 10^6 / 204.2 \times 438 = 1308 \text{ mm}^2/\text{m}$$

Try T16 @ 100 cc T & B (2011 mm<sup>2</sup> T & B)

Check deflection

$$\beta_b = 1.0, \quad f_s = 199.5 \quad k_1 = 1.256, \quad k_2 = 1.232$$

$$L/d \text{ allowed} = 21.1 \times 1.256 \times 1.232 = 32.65$$

$$L/d \text{ actual} = 7300 / 222 = 32.9 \text{ Say OK.}$$

Check for local failure

We now need to check whether the reinforcement that is now in place due to the inclusion of the line loads also satisfies the local failure criteria for the edge and corner columns.

a) **At column A1**

The previously established load,  $S$ , was 180 kN. The additional load is

$$12.39 \times 7.5 = 93 \text{ kN.}$$

$$S \text{ becomes: } 180 + 93 = 273 \text{ kN}$$

$$\text{For corner columns } 2 \quad m' = S \left( 1 - \sqrt{\frac{nA}{S}} \right)$$

$$\sqrt[3]{\frac{14.7 \times 0.1}{273}} = 0.175 \quad 1 - 0.175 = 0.825$$

$$m = m' = 273 \times 0.825 / 2 = 112.5 \text{ kNm/m}$$

<sup>55</sup> Along grid 1 in the centre bay there is a beam 250 mm wide by 600 mm deep adjacent to the opening. In instances like this, (where the slab over the clear width of the opening of 4875 mm is discontinuous but the edge of the slab, where the line load acts, it is continuous with the beam which forms a frame with the supporting column), it is up to the designer to decide how best to deal with the situation. The decision in this instance is to design the slab for the edge line load as being simply supported but when checking for the deflection to take into account the continuity offered by the adjoining beam.

However we know that the reinforcement provided here is as follows :

Top: T12@125 giving an  $m_r$  of 82 kNm/m

Bottom: T16 @ 100 both ways. Average  $d = (222 + 206)/2 = 214$  so average  $m_r = 2011 \times 0.88 \times 0.214 \times 0.438 = 166$  kNm/m

From the general form of the equation for corner columns in Table 3.11 we have:

$$1.57m + 0.43m' = S \left( 1 - \sqrt[3]{\frac{nA}{S}} \right)$$

$$1.57m + 0.43 \times 82 = 273 \times 0.825$$

$$m = 120.9 \text{ kNm/m}$$

As 120.9 is less than the 166 kNm/m provided OK.

This also complies with the condition  $m' \leq m$ .

b) **At column A2**

The previously established load,  $S$ , was 405 kN. The load increase due to the line load is :  $12.39 \times 7.5 = 93$  kN.

$S$  becomes :  $405 + 93 = 498$  kN

Now for edge columns:

$$5.14 m = S \left( 1 - \sqrt[3]{\frac{nA}{S}} \right)$$

$$\sqrt[3]{\frac{14.7 \times 0.1}{498}} = 0.143 \quad 1 - 0.143 = 0.856$$

$$5.14 m' = 498 \times 0.856$$

$$m' = m' = 83 \text{ kNm/m}$$

The top reinforcement provided here is as follows :

T16 @ 100 with  $m_r = 172$  kNm/m (parallel to edge as above)

T12 @ 125 giving  $m_r = 905 \times 0.95 \times 0.208 \times 0.438 = 78.3$  kNm/m (perpendicular to edge as Figure 4.1).

This gives an average of :

$$m' = (172 \times 2 \times 1.6 + 78.3 \times 3.75) / (3.2 + 3.75) = 121.4 \text{ kNm/m}$$

At the bottom :

T16 @ 100 giving  $m_r$  of 160 kNm/m (A1 to A2 as above)

T16 @ 175 giving  $m_r = 1150 \times 0.9 \times 0.222 \times 0.438 = 100.6$  kNm/m (A2 to B2 as Figure 4.1).

T16 @ 250 giving  $m_r = 804 \times 0.95 \times 0.206 \times 0.438 = 68.9$  kNm/m (A2 to A3 as above)

This gives an average of :

$$m = (160 \times 1.6 + 68.9 \times 1.6 + 100.6 \times 3.75) / (3.2 + 3.75) = 107 \text{ kNm/m}$$

It can be seen that both  $m$  &  $m'$  exceed the required 83 kNm/m so O.K.

c) **At column A3**

The increased load due to the line load here is similar to Col.A2 i.e. 498 kN. So here again  $m = m' = 83 \text{ kNm/m}$

The reinforcement provided here is as follows :

At the top :

T12 @ 125 with  $m_r = 78.3 \text{ kNm/m}$

T16 @ 150 giving  $m_r = 1340 \times 0.90 \times 0.222 \times 0.438 = 117.3 \text{ kNm/m}$

This gives an average of :

$$m' = (117.3 \times 2 \times 1.6 + 78.3 \times 3.75) / (3.2 + 3.75) = 96.3 \text{ kNm/m}$$

At the bottom :

T16 @ 175 giving  $m_r = 1150 \times 0.9 \times 0.222 \times 0.438 = 100.6 \text{ kNm/m}$

T16 @ 250 giving  $m_r = 804 \times 0.95 \times 0.206 \times 0.438 = 68.9 \text{ kNm/m}$

This gives an average of :

$$m = (68.9 \times 2 \times 1.6 + 100.6 \times 3.75) / (3.2 + 3.75) = 86 \text{ kNm/m}$$

It can be seen that both  $m$  &  $m'$  exceed the required  $83 \text{ kNm/m}$  so O.K

Summary

Local flexural failure is not critical.

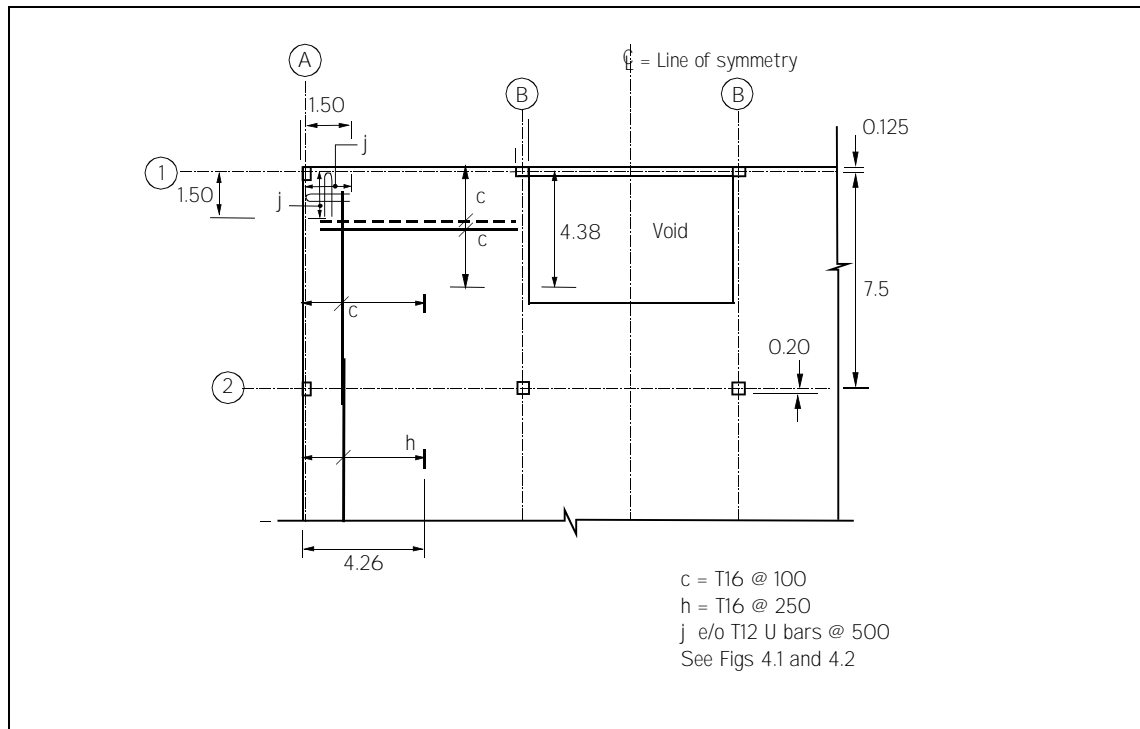
(With experience these types of justifications can be done 'by inspection'.)

Punching shear

Punching shear would need to be checked for the increased load of the cladding.

At Column A1 the load increase due to cladding is  $12.39 \times 7.5 = 93 \text{ kN}$ . It will be found that due to the new load of  $180 + 93 = 273 \text{ kN}$  the top reinforcement here has to be increased to T12 @ 100 cts each way in order to keep  $v$  below  $2v_c$ .





**Figure 4.3** Reinforcement layout with recess and edge load

*To be read in conjunction with Figures 4.1 and 4.2. Only reinforcement that has changed from Figures 4.1 or 4.2 due to the addition of the edge load is shown*

*The slab carries an 8.85 kN/m edge load, which is carried by edge strips in the slab. These strips have been analysed using formulae from Chapter 3.*

*All top reinforcement in column head areas remains unchanged. The additional bars marked j are required for punching shear. In practice the centres of the perimeter U-bars would be changed to match the revised reinforcement.*

## 4.3 Flat slabs on an irregular grid of columns

### 4.3.1 The problem

Quite often there is a need to use flat slab construction in a building where no regular column grid exists. Typically, this might be a multi storey block of apartments with planning permission (often with car parking below and little engineering input with respect to vertical structure!). It is then the engineer's task to find locations for columns such that do not interfere with usable areas (or buildability). If a solution can be found, columns will be confined to the lines and intersections of internal walls/partitions. Despite best efforts, this will inevitably give rise to an irregular layout of column and load-bearing walls.

Conventionally such slabs would be exceedingly difficult to analyse and design - even with the help of Finite Element Analysis. The following design method is based on years of practical experience. It awaits theoretical justification.

### 4.3.2 The solution

Yield Line Theory is well suited to deal with irregular slabs of this type, but a certain amount of experience is needed in visualising the possible failure patterns that could develop. Analysis of these slabs requires the designer to search for failure patterns that could form anywhere within the configuration of the supports. It must be borne in mind that the axes of rotation that define these patterns are located at the faces of the columns and that these axes can have any orientation on plan. The task is then to establish the pattern that produces the greatest moments. The types of patterns that should be investigated are as follows:

1. Always investigate first whether a straight, folded plate type, failure pattern can develop within the support lines, at any angle, from one extremity of the slab to the other. This would be the case for instance where a regular skew column grid exists and this type of failure would run at an angle following the skew.

Folded plate mechanisms can also 'snake around' while still complying with the rules for yield lines outlined in Table 1.2. In such cases analysis should be done using the Work method rather than totally reliant on formulae.

2. a) Search for the largest polygon that could be inscribed within any number of column and/or wall supports. The sides of the polygon form the axes of rotation that define the panel of slab that has been formed in this way. The sides can either be treated as continuous, when located within the body of the slab, in which case they will form negative yield lines or simply supported when located over columns situated along the edge of the slab. For many slabs it will be possible to confine this search for the worst case to quadrilaterals and apply appropriate formulae. For further information see *Bulletin d'information No.35* [2] cases 31 & 32. and Johansen's *Yield Line formulae for slabs* [6] under 2.2 and 2.3.

A quick, approximate, solution can be arrived at by considering the largest rectangle that can be inserted between the columns and walls in any location within the layout of the floor. This rectangle is then analysed as a slab supported along its sides which form the axes of rotation of the panel. Where the sides of the rectangle coincide with the edge of the floor slab a simple support must be assumed but where these are located within the floor area a negative yield line is formed.

- b) Around the perimeter of the slab (if stiff edge beams have not been provided) investigate panels where yield lines bisect the free edge.
- c) Check for cantilever, any part of the slab that projects beyond the perimeter of the slab forms a cantilever and as such can fail with a negative yield line forming along the axis of rotation which coincides with the line of supports.

- 3) Check for local failure mechanisms over supports as Table 3.10 and 3.11

When applying these methods of analysis it is prudent to increase the design moment by 15% (rather than the usual 10% in the 10% rule).

To arrive at an optimum design moment for the slab as a whole the number and shape of failure patterns investigated will depend on the designer's experience and confidence that the worst case patterns have been investigated and catered for. For the less experienced, there is comfort in the fact that considering slabs in the failure patterns listed above will have been increased by 15 % to cater for the approximations inherent in this approach. There is also the added reassurance that the beneficial effect of membrane action has not been taken into account. Further enhancement to the resistance moment will usually be provided to comply with serviceability requirements.

Again, lateral stability, moments induced in columns, column connections and punching shear should be considered separately. For the purpose of flexural design of the slab, the column connection to the slab is considered as being theoretically pinned.

The design usually ends up with a continuous mat of reinforcement, of an isotropic nature, top and bottom each way. Additional top reinforcement is added in the vicinity of the columns to deal with the peaking serviceability moments and to enhance the punching shear resistance. It has the additional role of precluding a local cone type failure, centred on the column supports, from occurring. Additional bottom reinforcement is sometimes required in the larger panels to deal with larger span moments and, more usually, to comply with deflection criteria. Providing isotropic orthogonal reinforcement has the advantage of simplifying the placing of bars and ensures that the design is valid for any orientation of the Yield Line pattern.

Because of the random nature of the column positions it pays, for simplicity of placing and detailing of the reinforcement, to have mats of top and bottom reinforcement throughout. If these mats are provided with full tension laps bars can be spliced at positions suited to the construction process and convenient bar lengths. This isotropic arrangement of reinforcement is also well suited to deal with any failure pattern that may arise. It can also be supplemented with extra top reinforcement at selected column positions to enhance shear resistance and deal with peak moments at the serviceability stage.

### 4.3.3 Punching shear

According to BS8110, equation 25 et seq, the design effective punching shear force is dependant on the moment transferred to the column. With perimeter columns, moment transfer is limited to  $M_{t_{max}}$  and punching shear design for these irregular flat slabs follows normal methods.

However, there is no such  $M_{t_{max}}$  limitation for internal columns - because in usual regular layouts the transfer moment is small and the breadth of the effective moment transfer strip is unlimited. In irregular layouts the internal columns can be subject to theoretically high transfer moments and therefore to high design effective punching shears,  $V_{eff}$ . The calculation of transfer moment in such situations is a matter of judgement and experience. In this respect, either the methods presented in BS8110 or those described in Park and Gamble [11], chapter 2.11 should be followed.

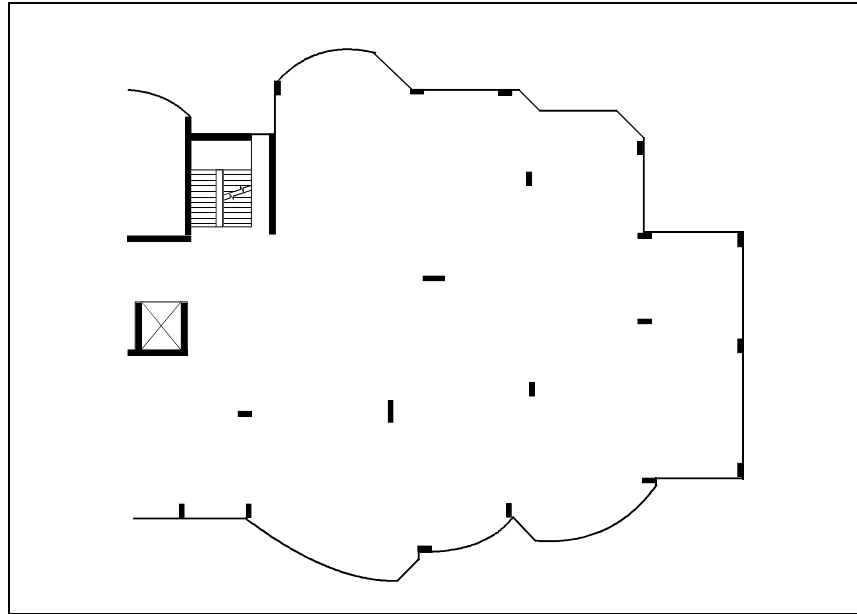
The calculation of  $V_t$ , the design shear transferred to the column, is also a matter of experience and judgement and the designer should bear in mind clause 3.8.2.3 in BS 8110. This clause states that in braced monolithic construction, axial forces in columns may be calculated assuming slabs are simply supported.

Where punching shear becomes critical the designer is referred to Regan [50] and to Chana and Desai [49]. Regan points out that flat slabs are generally too flexible to be able to transfer the high moments indicated by a linear element elastic analysis. Chana and

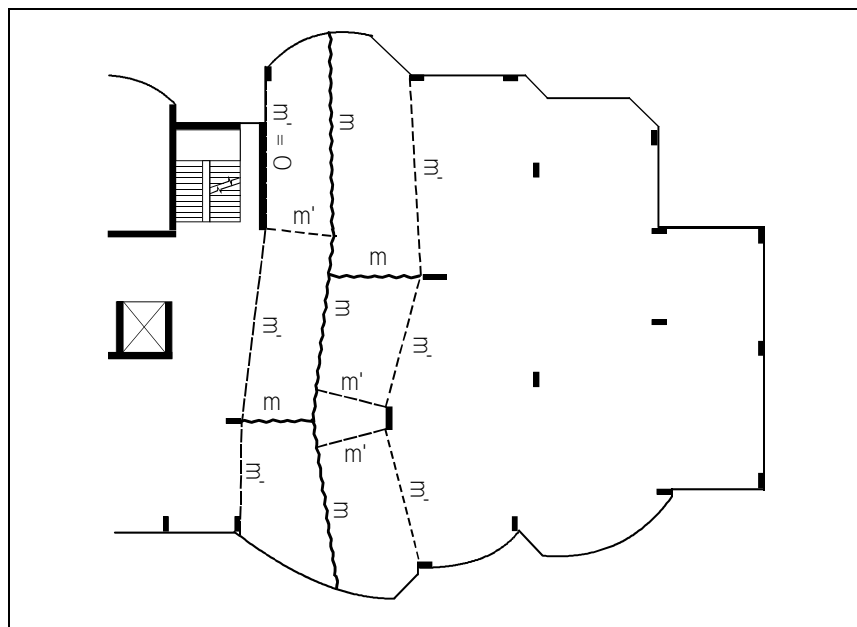
Desai [49] discuss how membrane action, which is usually ignored in design, may be taken into account to enhance punching shear resistance around internal columns.

### 4.3.4 An example

The following example is based on Figure 4.4, which is the part-plan of one storey in a seven-storey block of flats in London. The construction consists of a 250 flat slab throughout without any upstands or downstands supported on blade columns and R.C. walls around the core. Some of the patterns investigated are shown in Figures 4.5a and 4.5b.



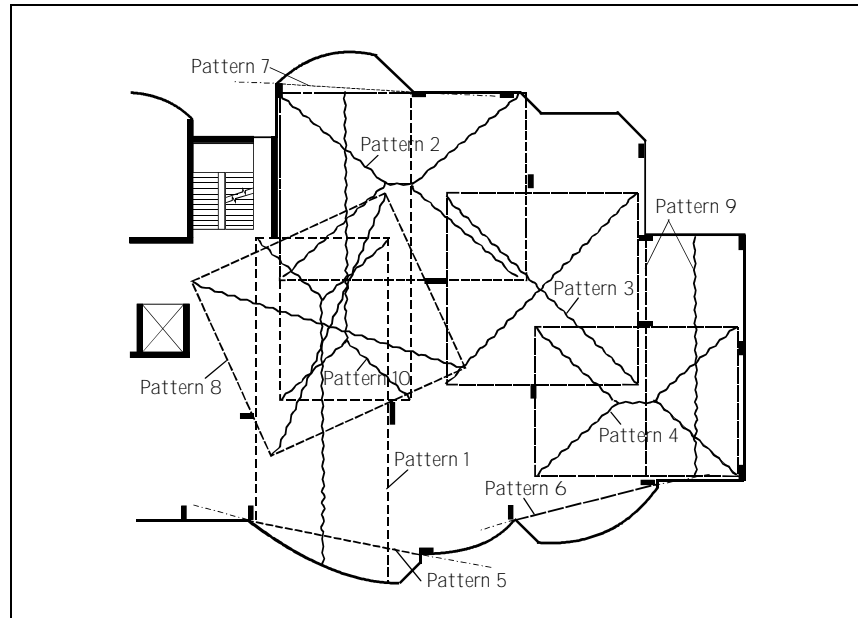
**Figure 4.4** Part general arrangement drawing of a block of flats



**Figure 4.5a.** Part general arrangement drawing of a block of flats showing a 'folding plate' mechanism that needs to be investigated

There are various potential folding plate mechanisms. Presuming a constant udl across the whole slab, the pattern indicated in Figure 4.5a is likely to be critical as it has the largest 'average' span. Other folding plate mechanisms should be considered and some of these are shown in Figure 4.5b.

The analysis for the folding plate shown in Figure 4.5a could range from simply considering it as a folding plate and using the formula in Table 3.1, to a more detailed Work Method analysis.



**Figure 4.5b.** Part general arrangement drawing of a block of flats showing some of the possible polygonal failure patterns that need to be investigated

*Patterns 1 and 10 assume slabs supported on three sides, the lines of support being the axes of rotation. Patterns 2, 3 4 and 8 assume four axes of rotation along lines of supports. Patterns 5, 6 and 7 are possible cantilever modes of failure. Pattern 9 is a straight line folded plate type of failure*

All the patterns in Figure 4.5b should be investigated. The various possible failure patterns shown give an indication of how a designer would approach the analysis of a slab of this kind. Calculations would typically be as the calculation for pattern 8 given in Example 4D.

### Example 4D

### Irregularly supported flat slab using the Work Method

Investigate pattern 8 in Figure 4.5b assuming  $n = 21.7\text{kN/m}^2$  and layout as follows:

Slab layout :

Concrete C40 Cover 20 mm T&B Slab thickness 250 mm,  $n = 21.7 \text{ kN/m}^2$

Analysis

Pattern 8, is considered as a panel of a slab supported on four sides. Applying the Work method and choosing  $m = m'$

$$E = 7.85 \times 8.25 \times 21.7 \times 1/3 = 469$$

$$D = \begin{aligned} &2 \times 8.25 \times m \times 1/3.925 &&= 4.2m \\ &2 \times 7.85 \times m \times 1/4.125 &&= 3.8m \\ &m' \times (8.25 + 6.75) \times 1/3.925 &= 3.8m' &&= 3.8m \\ &m' \times (7.85 + 6.85) \times 1/4.125 &= 3.5m' &&= 3.5m \\ &&&&&& \hline &&&&&& 15.3m \end{aligned}$$

From  $D = E$ , we get :

$$15.3m = 469$$

$$m = 469 / 15.3 = 30.65 \text{ kNm/m}$$

Allow 15% increase :

$$m = m' = 30.65 \times 1.15 = 35.25 \text{ kNm/m}$$

#### Commentary on calculation

In practice a number of patterns, some of which are shown in Figure 4.5a and 4.5b, would be investigated and a worst case taken.

Analysing the folding plate pattern, Pattern A, shown in Figure 4.5a using the work method, would have produced a moment of approximately 48.6 kNm/m, assuming the ultimate load to be 21.7 kN/m<sup>2</sup> across the whole slab. The design moment would have been 48.6 x 1.15 = 55.8 kNm/m. In the analysis, the same principles as used in Chapter 2 are used: the yield lines obey the same rules. The exact pattern may be a little difficult to predict but there is some comfort

in checking a number of patterns. As a rough check, it might be considered that failure in this bay is akin to a straight plate failure and by applying Table 3.1, case 1 with  $i_1=0.66$  and  $i_2 = 1.00$  and an 'average'  $L = 5.6$ , an  $m$  of  $46.6 \text{ kN/m}$  (design moment,  $53.6 \text{ kNm/m}$ ) would have been derived.

At first glance, it might appear that pattern 8 would be the most critical of the potential large polygon failures. However, similar calculations to Example 4D for the all patterns indicated in Figure 4.5b (but using simple  $45^\circ$  layouts for the yield lines) produce the following results:

Pattern no.	1	2	3	4	5	6	7	8	9	10	A
$m$ (kNm/m)	33.2	37.6	23.8	29.3	21.3	21.3	24.4	30.6	20.3	36.3	48.6
<b>1.15 x m</b> (kNm/m)	38.1	43.3	27.3	33.7	24.5	24.5	28.1	35.2	23.4	41.8	55.8

It will be seen that patterns 1, 2, 10 and A produced more critical results than pattern 8. It will be noted that patterns 1, 2 and 10 have discontinuous edges. Pattern 9 is a folded plate pattern but less onerous than pattern 8 shown in Figure 4.5b, because the span is relatively small. Other possible failure patterns involving other polygons should also be considered. However, the 'm' for pattern 2 appears critical and would, subject to consideration of other failure patterns across the whole slab be judged suitable to be the basis for reinforcing the whole slab. Obviously, the worst case, the folded plate pattern A would have to be accommodated by supplementing with additional top and bottom reinforcement.

Local fan type modes of failure at column supports would be checked in the usual way, as would deflection and punching shear.

In general, reinforcement consisting of T12 bars at 200 centres each way top and bottom giving a moment capacity of  $51.2 \text{ kNm/m}$  would appear to be a sensible solution. The reinforcement in the more onerous panels would be supplemented with extra T12s at 200 centres.

However, real slabs tend not to be so simple!

Indeed, the analysis for the actual slab used as the basis for the above example had to cater for different uniformly distributed loads, line loads, holes, discontinuities etc, etc. Analysis included an exhaustive consideration of failure patterns over the whole slab and Figure 4.6 shows part of the resulting reinforcement drawing. The slab was considered as a whole and provided with T12 @ 200 each way top and bottom throughout ( $h = 250 \text{ mm}$ :  $m_r = 51 \text{ kNm/m}$ ). This arrangement catered for the design moments over most of the slab.

Over most columns, additional top steel, in the form of T12 @ 200 T, was added locally to give effectively T12 @ 100 T to preclude local failures from occurring and to enhance punching shear resistance. Some of the columns had punching shear reinforcement added. In some panels additional T12 @ 200B were used to enhance moment capacity and to ensure the slab conformed with span-to-depth ratios. The cantilever balconies were reinforced with T12 at 100 centres.

This level of rationalisation of reinforcement was considered appropriate for the desired level of buildability. In the event, fixing times were very quick and lead to considerable overall time savings and therefore significant savings in costs over more traditional methods of reinforcing such slabs.

As can be seen in Figure.4.6 the reinforcement is laid out in the direction of the longitudinal axis of the building and at right angles to it. Normally, a panel would have reinforcement running parallel with the sides. This is not the case with panel 8 but with isotropic slabs, as this one is, provided the reinforcement in the two directions are at right-angles, the moment capacity of the slab is the same no matter what the orientation of the bars (see Appendix).

The design of these slabs is not difficult. However, it does require thoroughness, confidence and judgement!

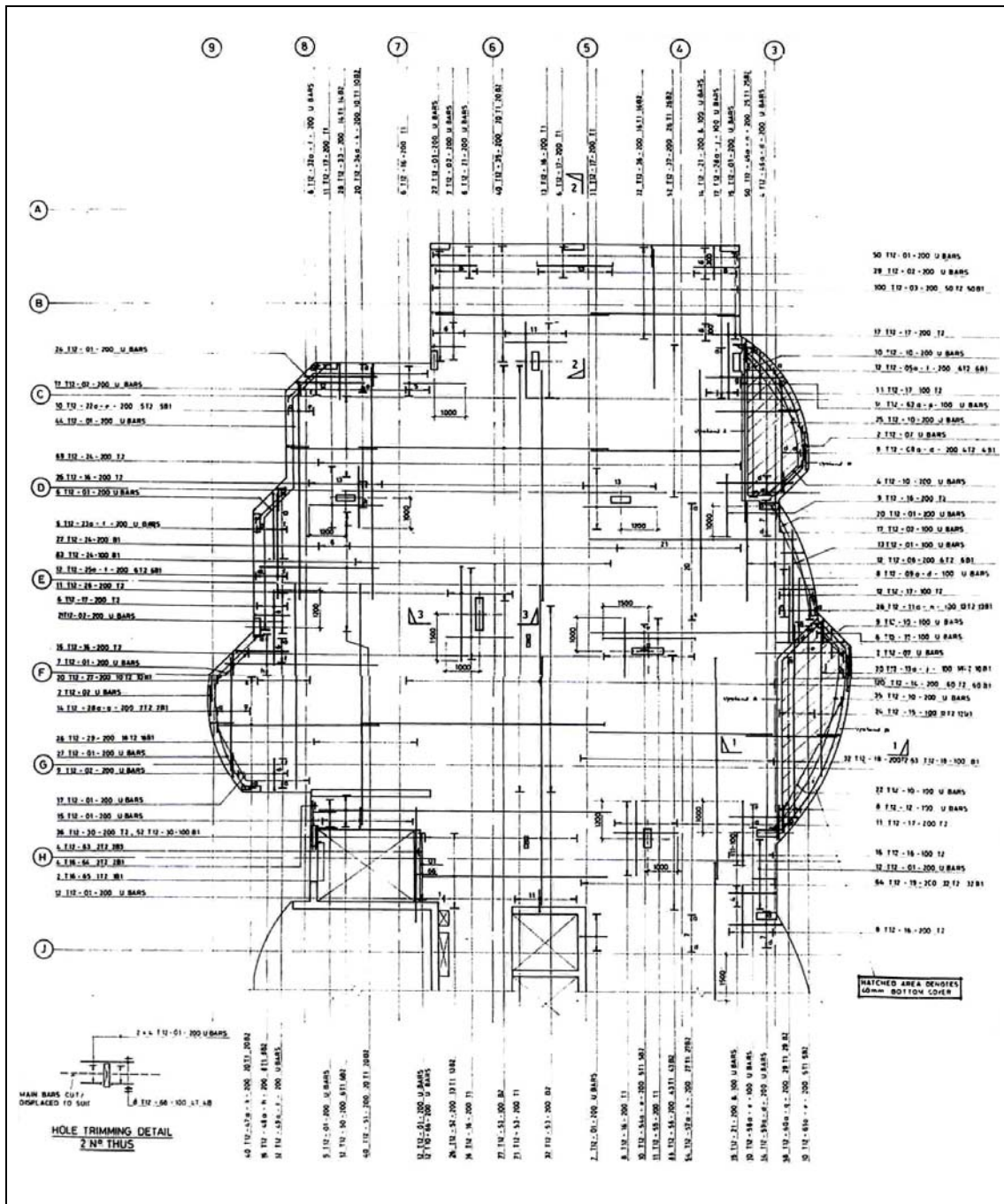
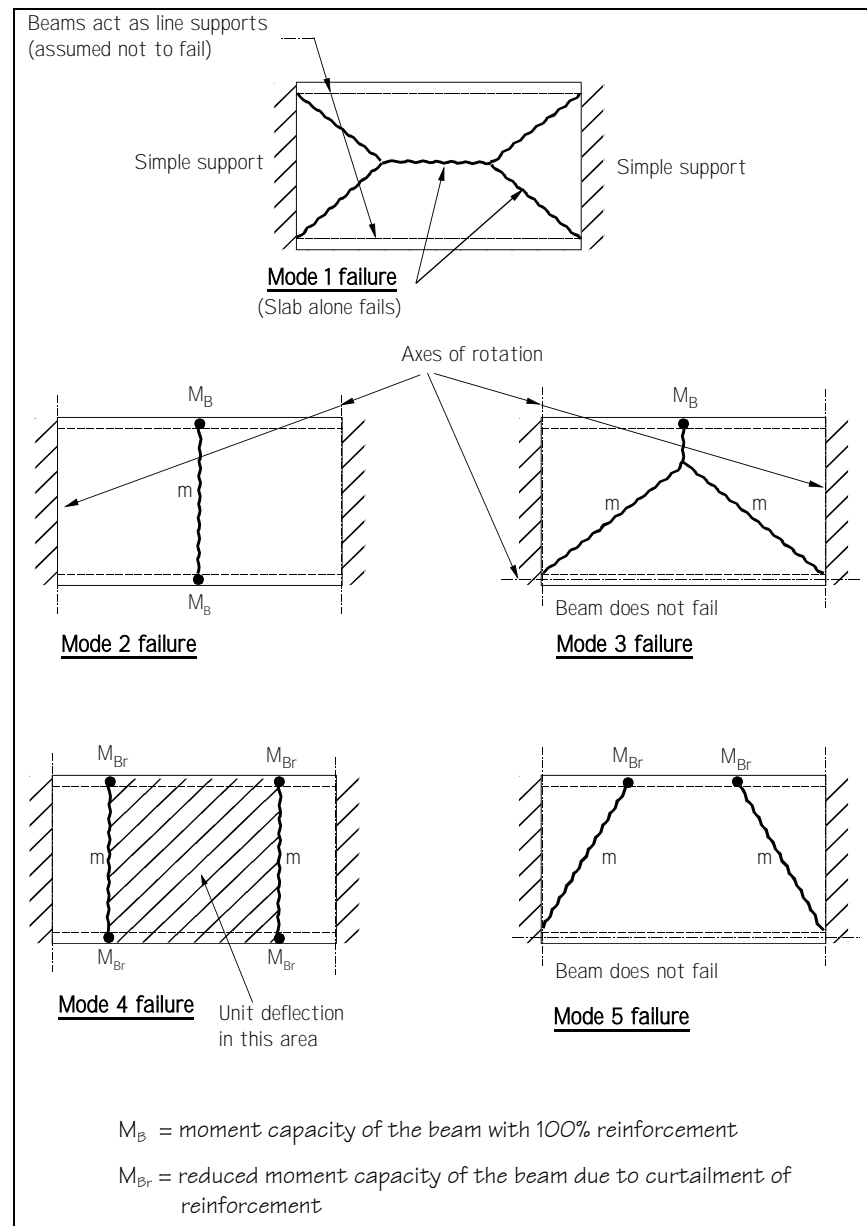


Figure 4.6. Extract from the actual reinforcement drawing for the slab used in Example 4D



## 4.4 Slabs with beams

A valid yield line pattern may include yield lines that pass through beams. Including beams in the collapse mechanism of a slab is only a theoretical extension of the principle of providing localised strong bands of reinforcement within the depth of a slab. Consider the slab shown at the top of Figure 4.7. This slab has edge beams and the combination spans between two walls. A 45-degree load dispersion is shown as a mode 1 failure (this dispersion is really only valid if the four supports, i.e. the wall and beam supports, are regarded as being equally stiff). Other possible failure patterns are shown as modes of failure 2 to 5.



**Figure 4.7** Possible modes of failure for a slab supported by beams and walls

As the supporting beams become less stiff, the points of the triangular regions in the mode 1 failure pattern come together, meet and then flatten as they meet. Eventually, the beams

act more like strong bands either side of the slab leading to a mode 2 failure pattern. This composite slab now spans between the wall supports - the load being shared between the slab and the beams in proportion to their respective moments of resistance (c.f. elastic theory where they would be shared according to their stiffness).

If both beams are of the same strength we get failure mode 2. If only one beam is weak then we can get failure mode 3. If the bottom main bars in the beam in modes 2 and 3 are curtailed too soon, reducing the plastic resistance moment then an alternative failure pattern has to be investigated as shown by modes 4 & 5 respectively.

Please note that between modes 1 and mode 2, the span of the slab has changed direction! This obviously has an impact on the serviceability design of the combined system. It may even become necessary to increase the slab thickness because of the change in span.

#### 4.4.1 Design procedure

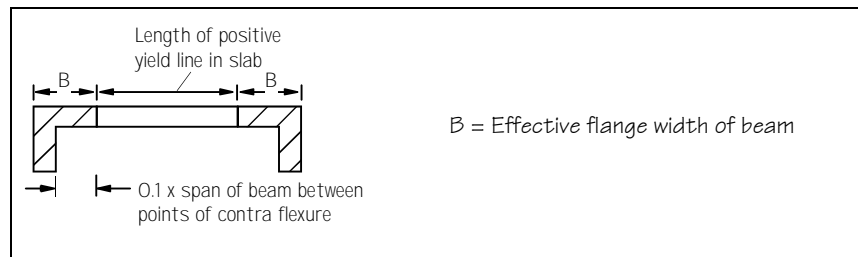
Taking the same layout of the floor as shown in Figure 4.7 the procedure for analysing this beam and slab structure would be as follows:

First determine the minimum strength of the slab on the assumption that the beams are strong enough to act as line supports so that when the slab is loaded to failure only the slab fails, leaving the beams intact. This is shown as failure mode 1 in Figure 4.7. Then analyse patterns that involve the collapse of both the slab and the beams. Mode 2 will be of greatest interest, but if the reinforcement in the beams is to be curtailed or there is some other reason for the plastic resistance moment to be reduced then alternative failure patterns have to be investigated.

In all these modes of failure the designer is free to choose any values of slab and beam strengths that satisfy the relationships imposed by the Work Method of analysis provided the slab strength is greater than or equal to that calculated for the collapse of the slab alone.

It will be appreciated that part of the slab acts compositely with the downstand beam to form an inverted L-beam. When considering the plastic moment of resistance of the inverted L-beam, there must exist a length over which the neutral axis of the T-beam section reduces to that of the slab. M Kwiecinski [20] in his work on slab-beam systems says that the effective width of the compression flange should be taken from the relevant clauses in the Code of Practice one is working to. For an L-beam to BS 8110 (and EC2), this width is the web width plus 0.1 times the beam length between points of contraflexure. Please note that the length of positive yield line in the slab excludes the width of the beam flange.

If an accurate assessment of deflection is required then, the designer is recommended to apply finite element theory to tackle the problem. Otherwise, the designer must use his or her experience and judgement to assess whether deflection is likely to be critical by say checking span : depth ratios.



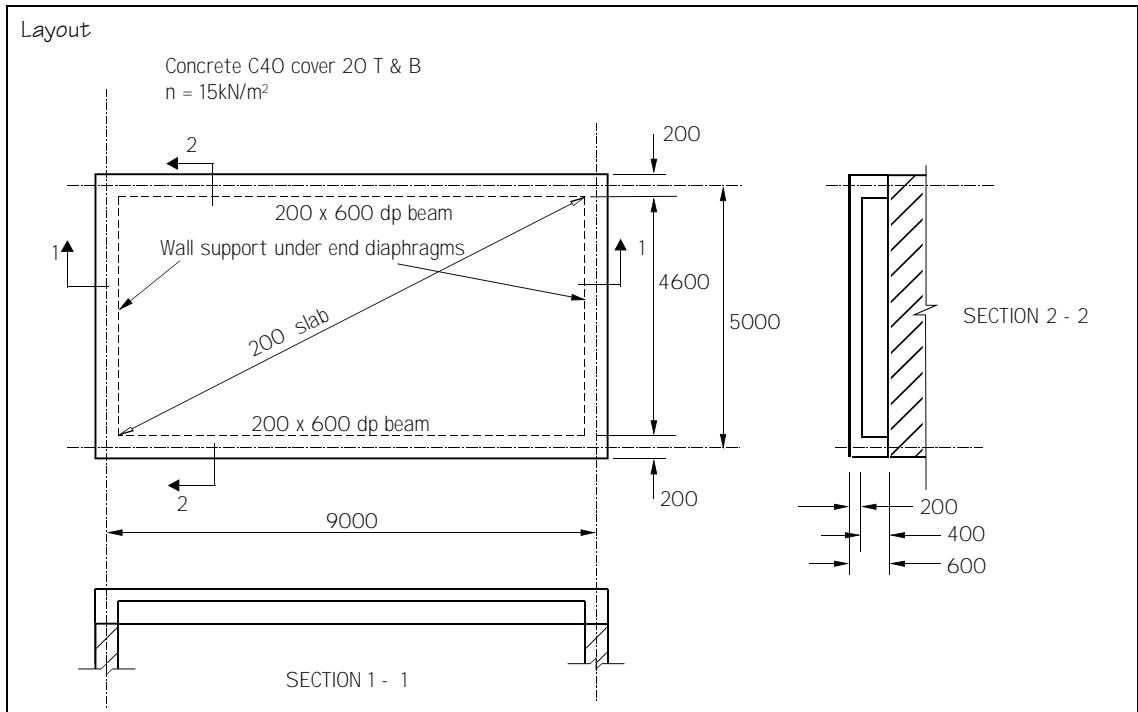
**Figure 4.8** Section through slab and beams showing length of positive yield line in slab and beam flange width in a mode 2 failure.

**Example 4E**

**Two-way slab with beams using formulae (flexible beams)**

Analyse and design a pedestrian link bridge in an atrium consisting of two edge beams 200 × 600 mm deep and a 200 mm slab, 5.0 m wide having a span of 9 m between two supporting walls.

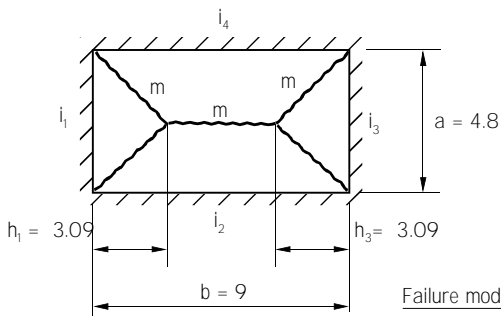
The total ultimate uniformly distributed load is 15 kN/m<sup>2</sup>, concrete C40, cover 20mm T&B.



Analysis and Design

Failure Mode 1 (refer Figure 4.7).

Check slab and failure mode 1 – assume that the beams do not fail.



Failure mode 1

On the assumption that the beams do not fail

Assuming isotropic reinforcement and  $i_1 = i_2 = i_3 = i_4 = 0$ ,

then with reference to Table 3.6a

$$a_r = a = 4.8; \quad b_r^* = b = 9.0; \quad n^* = n = 15$$

$$\alpha = \beta = 0$$

$$m = \frac{n^* \times a_r \times b_r^*}{\beta \left( 1 + \frac{b_r^*}{a_r} + \frac{a_r}{b_r^*} \right)} = \frac{15 \times 4.8 \times 9}{8 \left( 1 + \frac{9}{4.8} + \frac{4.8}{9} \right)}$$

$$m = 23.8 \text{ kNm/m}$$

$$h_1 = \sqrt{\frac{6(1+i_1)}{n(1+3\beta)} \frac{m}{15}} = \sqrt{\frac{6 \times 23.8}{15}}$$

$$h_1 = h_2 = 3.09 \text{ m}$$

Slab reactions on beams:

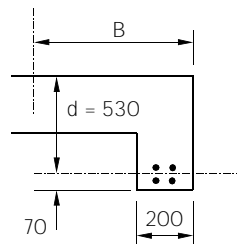
$$q_2 = 4m \left( \frac{1}{a_r} + \frac{1}{b_r} \right) \times \sqrt{1+i_2}$$

$$= 4 \times 23.8 \left( \frac{1}{4.8} + \frac{1}{9} \right) = 30.4 \text{ kN/m}$$

$$q_2 = q_4 = 30.4 \text{ kN/m}$$

The ultimate moment in the beam<sup>TT</sup>:

$$M_B = \frac{q_2 \times b^2}{8} = \frac{30.4 \times 9^2}{8} = 308 \text{ kNm}$$



$$B = 0.1 \times 9 + 0.2$$

$$= 1.1 \text{ m}$$

$$M/bd^2f_{cu} = \frac{308 \times 10^6}{1100 \times 530^2 \times 40} = 0.024 \quad \therefore z = 0.95d$$

$$A_{s_{req}} = \frac{308}{0.95 \times 0.53 \times 0.438} = 1397 \text{ mm}^2$$

Provide 2T25 + 2T20

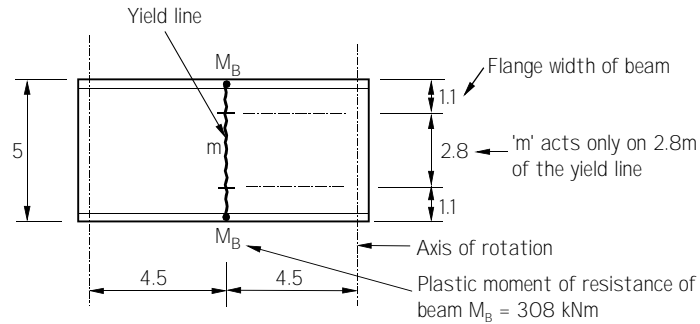
$$(982 + 628 = 1610 \text{ mm}^2/\text{m})$$

This will ensure that the beam will sustain the slab load without failing. However, check against failure mode 2.

<sup>TT</sup> For simplicity, use  $wl^2/8$  as per both Yield Line Analysis and Elastic Analysis.

Failure mode 2.

Check failure mode 2 which embraces failure in both slab and beams:



Apply the work method to establish the required 'm' for the slab for this mode of failure to occur with  $M_B$  chosen at 308 kNm

$$E: 15 \text{ kN/m}^2 \times 9.0 \times 5.0 \times \frac{1}{2} = 338$$

D :

$$\begin{aligned} 2 \times 2.8\text{m} \times \frac{1}{4.5} &= 1.244\text{m} && \text{[2}\theta \text{ rotation]} \\ 4 \times 308 \times \frac{1}{4.5} &= 274.0 && \text{[2 beams, } 2\theta \text{ rotation]} \\ \Sigma &= 1.244\text{m} + 274 \end{aligned}$$

From  $D = E$  we get:

$$1.244\text{m} + 274 = 338$$

$$m = \frac{338 - 274}{1.244}$$

$$m = 51.44 \text{ kNm/m}$$

This mode of failure requires the slab moment of resistance to be 51.44, which is more than 23.8 of mode 1. Therefore this mode of failure would take precedence over mode 1 and the slab resistance moment in the longitudinal direction would have to be increased to 51.44 kNm/m.

However, the reinforcement provided in the beams has an area of  $1610 \text{ mm}^2$ . This gives an  $M_{B,r}$  of  $1610 \times 0.95 \times 0.53 \times 0.438 = 355$ , instead of the computed 308 kNm.

So substituting this value into D:

$$\begin{aligned} 2 \times 2.8\text{m} \times \frac{1}{4.5} &= 1.244\text{m} \\ 4 \times 355 \times \frac{1}{4.5} &= 316.0 \\ \Sigma &= 1.244\text{m} + 316 \end{aligned}$$

From  $D = E$  we get:

$$1.244\text{m} + 316 = 338$$

$$m = \frac{338 - 316}{1.244}$$

$$m = 17.7 \text{ kNm/m}$$

As this moment is less than 23.8 of mode 1, this mode of failure will not take precedence due to the enhanced  $M_{Br}$  of the beams.

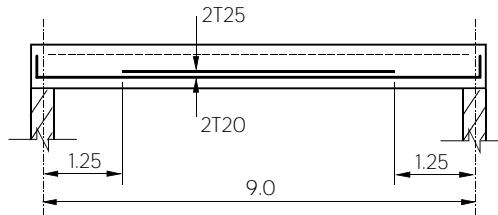
The slab will, nevertheless, have to be designed for the larger moment of 23.8 to prevent the slab failing on its own.

Failure mode 3

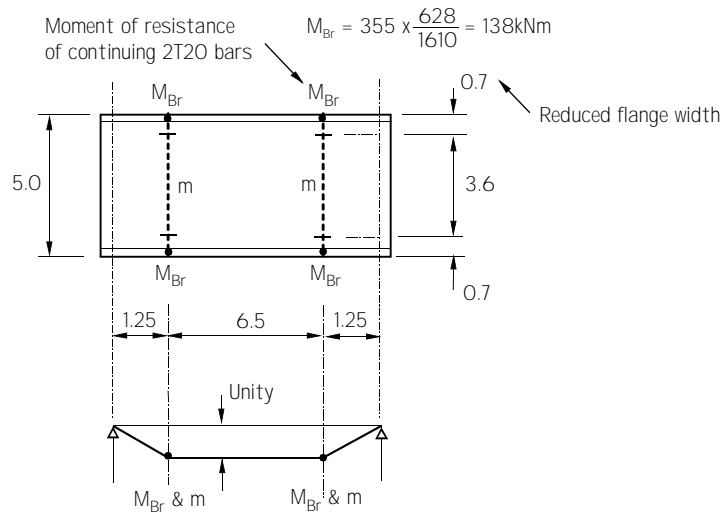
By inspection, not critical

Failure mode 4.

Investigate the effect curtailment of the beam bars can have on the ultimate moment in the slab. Try stopping off the 2T25 bars 1.25 m from the supports each end:



The possibility of mode 4 failure pattern has to be investigated:



$M_{Br}$  = moment of resistance of the continuing reinforcement, (2T20 = 628 mm<sup>2</sup>)

Conservatively,  $M_{Br} = 355 \times 628 / 1610 = 138 \text{ kNm}$

E:

$$15 \text{ kN/m}^2 \times 6.5 \times 5 \times 1 = 487.5$$

$$15 \text{ kN/m}^2 \times 2.5 \times 5 \times \frac{1}{2} = 93.75$$

$$\Sigma = 581.25$$

D:

$$2 \times 3.6 \text{ m} \times \frac{1}{1.25} = 5.76 \text{ m}$$

$$4 \times 138 \times \frac{1}{1.25} = 442.0$$

$$\Sigma = 5.76 \text{ m} + 442$$

From D = E we get:

$$5.76 \text{ m} + 442 = 581.25$$

$$m = \frac{581.25 - 442}{5.76} \quad \underline{m = 24 \text{ kNm/m}}$$

Now this is approximately equal to the moment in the slab for mode 1, i.e. 23.8

So one can conclude:

- Curtailing bars more than 1.25 m from supports would initiate failure mode 4 with an increase of mode 1 slab moments.
- Curtailing the 2 T25 bars less than 1.25 m from supports would prevent mode 4 from developing and mode 1 would be applicable.

For completeness:

Slab reinforcement

$$d = 200 - 20 - \text{ave } 10 = 170 \text{ mm}$$

$$M/bd^2f_{cu} = \frac{24 \times 10^6}{1000 \times 170^2 \times 40} = 0.021 \quad \therefore z = 0.95d$$

$$A_{s, req} = \frac{24}{0.95 \times 0.170 \times 0.438} = 339 \text{ mm}^2$$

$$\text{Min } 0.13\% = 0.0013 \times 250 \times 1000 = 325 \text{ mm}^2$$

Provide T10 @ 200 both ways T&B (392 mm<sup>2</sup>/m)

By inspection deflection of slab and beams OK. Top steel provided to reduce shrinkage creep and deflection.

Shear in beams

$$v = 30.4 \times 10^3 \times 9 / (2 \times 200 \times 530) = 1.29 \text{ N/mm}^2$$

$$100 A_s/bd = 100 \times 628 / 200 / 530 = 0.59\%$$

$$v_c = 0.624$$

$$A_{sv}/s_v \geq 200 (1.29 - 0.62) / 438 = 0.306$$

Provide T10 links in 2 legs @ 300 cc (0.52)

**Summary**

In slab, provide T10 @ 200 bw T&B ( $392 \text{ mm}^2/\text{m}$ )

In beams, provide 2T25 + 2T20B ( $982 + 628 = 1610 \text{ mm}^2$ ).

Curtailed 2 bars max 1.25 m from supports. Provide T10 links in 2 legs @ 300 cc (0.52)

**Commentary on example**

The beams in this example were deliberately chosen to be flexible in order to emphasize the need to exercise caution in the design process. If the beams had been made 900 mm deep initially then the design would have been straightforward.

The comment made earlier about deflections at service loads still apply and if there is not the time or the facility to revert to Finite Element Analysis then one should always seek to provide a generous span/depth ratio for the beams and, if necessary, also reduce the working stress in the reinforcement by providing more tensile reinforcement than would be required for ultimate design alone.

This example clearly demonstrates how Yield Line Theory enables a designer to optimise the effectiveness of a structural layout. An experienced designer would recognize the need to concentrate the reinforcement in the slab in the direction of the span of the beams in order to enhance the performance of this beam-and-slab system. If therefore an orthotropic arrangement of reinforcement were chosen where the ratio of longitudinal steel was twice that of the transverse steel, the Yield Line Analysis for failure mode 1 would produce a moment of  $37.2 \text{ kNm/m}$  in the long direction and  $18.6 \text{ kNm/m}$  in the short direction. If we then chose to reinforce the beam with only 3 T25 ( $1473 \text{ mm}^2$ ) as opposed to the  $1610 \text{ mm}^2$  this would give the beam a moment of resistance of  $331 \text{ kNm}$ . The Work Method for failure mode 2 would then require a slab moment of  $35.37 \text{ kNm/m}$  which is less than  $37.2 \text{ kNm/m}$  provided by mode 1 so that mode 2 would not be critical.

The purpose of providing top reinforcement throughout the slab is to reduce long-term creep and shrinkage deflections. It is not in this case a design requirement.



---

## 4.5 Transfer slabs

The most economic form of vertical structure is to have all vertical load-bearing elements located above each other so that there is a direct path for all the loads down to the foundations. When this cannot be done, for instance when office grids do not coincide with ground or basement car-parking layouts below, then some form of transfer structure is required. The transfer of load can be achieved by a system of transfer beams, which are costly and time-consuming to design and construct. Where the loads to be transferred are spread over a large area it becomes more economic to transfer the load by using a flat slab.

Again Yield Line Theory can be applied to give simple solutions for these types of slabs. The Yield Line Analysis will follow the same Work Method procedure as before. The only difference is that the analysis must deal with substantial point and/or line loads: in comparison, any uniformly distributed load at that level will be comparatively small.

The yield line pattern for global failure will be attracted towards these isolated loads. When there is a dominant point load present, there is the necessity to check whether a local failure under this load will not produce a larger moment.

When there is a combination of loads, as is generally the case for transfer slabs, it is useful to know that although the law of superposition is not valid. Nonetheless in Yield Line Theory can be used. It will always be on the safe side to find the solutions for the loads acting independently and then add these resulting moments together to give a final design moment. The moment arrived at in this way will always be greater than the correct moment that would have arisen due to the loads acting together. The key to how accurate the resulting moment is depends on how divergent the individual yield line patterns are. The more divergent these patterns are from each other the less accurate the result i.e. the greater the conservatism. For example a circular slab supported around the perimeter and loaded with a central point load and a uniformly distributed load will produce the same final moment whether analysed for the combined loads or for them separately and then added together. This is because the crack pattern is exactly the same.

The very nature of this type of slab, supporting substantial point loads and/or line loads, will demand a lower span/depth ratio not only for the serviceability considerations but also with respect to the higher shear loads generated.

For the interested reader this topic is covered in detail in references[14] and [16].

## 4.6 Raft foundations

Yield Line Theory provides a simple method of designing raft foundations, either ground-bearing or piled, which will be adequate in the majority of cases encountered in practice. Sophisticated theories and computer programs for the design of complex raft foundations do exist. They can take into account soil/structure interaction and for buildings that warrant this approach, the designer would be justified in pursuing that line of action [27,28].

Here, it is not intended to enlarge upon how the loading on the rafts was actually arrived at but to concentrate solely on how Yield Line Theory is used to analyse a raft with given loading.

Foundation rafts come in the same shapes as floor slabs, the only difference being that they are loaded by the reactions in the ground, brought about by the load of the structure the rafts support. In this respect they may be considered as inverted floor slabs and may be designed as such. Unlike elastic methods, plastic and Yield Line methods are independent of deformations, deflections, movements or settlements. Rather than factor up a serviceability limit state case, Yield Line methods consider the ultimate limit case from the outset. Serviceability is usually a matter of soil/structure interaction and is beyond the scope of this publication.

In principle, there are two types of raft foundations, those resting on soil and those resting on piles. In the former, the load on the raft is considered to be distributed linearly depending on the eccentricity of the resultant load with respect to the centre of gravity of the raft itself. However, Johansen [6] showed that an excellent approximation of the ultimate moments can be achieved by considering the same total load but uniformly distributed. In piled rafts, the piles represent a series of point loads on the slab. The magnitude of these point loads would have been established previously from the elastic foundation design, but factored to give ultimate loads.

When embarking on a raft design, the first step is to identify the main vertical load-bearing elements of the structure that transfer the bulk of the load of the building and its contents to the foundation. These columns and walls will become the support system for the design of the raft as an upside down slab. Any other vertical elements that support only a relatively small part of the total load should be treated as line or point loads acting against the upward soil reaction (and would therefore constitute a relieving load on the raft subject to the appropriate partial safety factor for relieving load).

There is a definite advantage in having concrete walls as a means of transferring loads to a raft as they provide extra rigidity and also help in reducing the magnitude of the applied moments and shear forces. Isolated column supports have to be checked for punching shear. Once the ultimate loads on the raft have been established the Work method of analysis can be applied to determine the design moments. When applying the Work method, any gravity loads acting on the raft are taken as negative in the procedure for evaluating the expenditure of external forces.

The sizing of foundation rafts is very much a matter of experience and is influenced by soil conditions and the rigidity of the structure it supports. A good indication of whether the raft is thick enough to perform satisfactorily is given by the amount of reinforcement that is needed to comply with the design moments. The opinion on what this maximum amount should be is somewhat subjective but from the main author's experience this would be in the region of 0.4% to 0.5% T&B both ways.

The thickness of rafts can also be influenced by considerations of punching shear, notably if the raft is supporting edge columns. Some designers like to avoid punching shear reinforcement, but some flexibility in rafts is desirable to keep bending moments and shear stresses to a minimum. However, flexibility must be related to the allowable distortion in the superstructure [27].

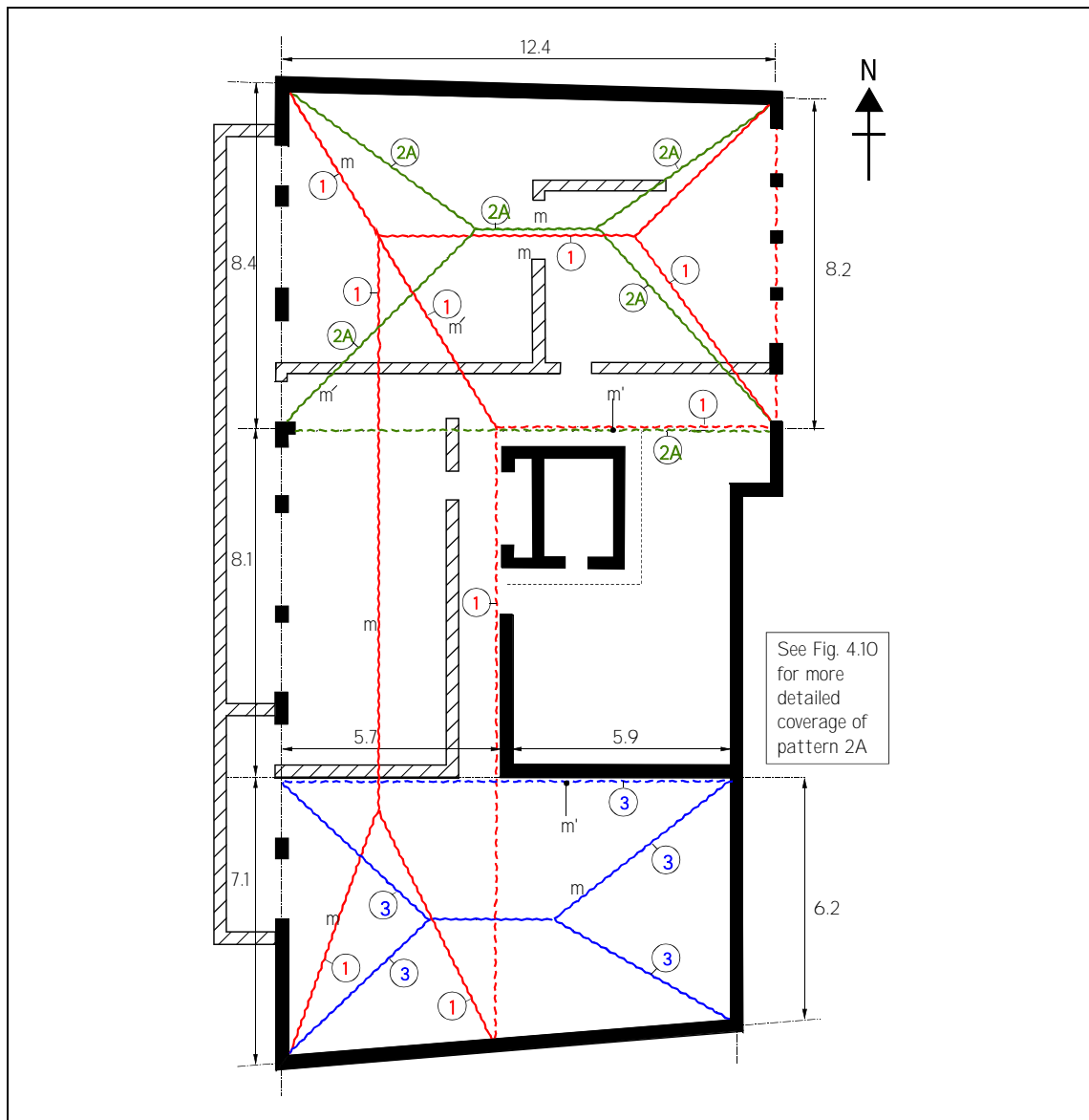
## Example 4F

### Piled raft using the Work Method

Example 4F is taken from a building in London and shows the analysis and design of a 600 mm thick piled raft supporting a seven-storey building (including basement).

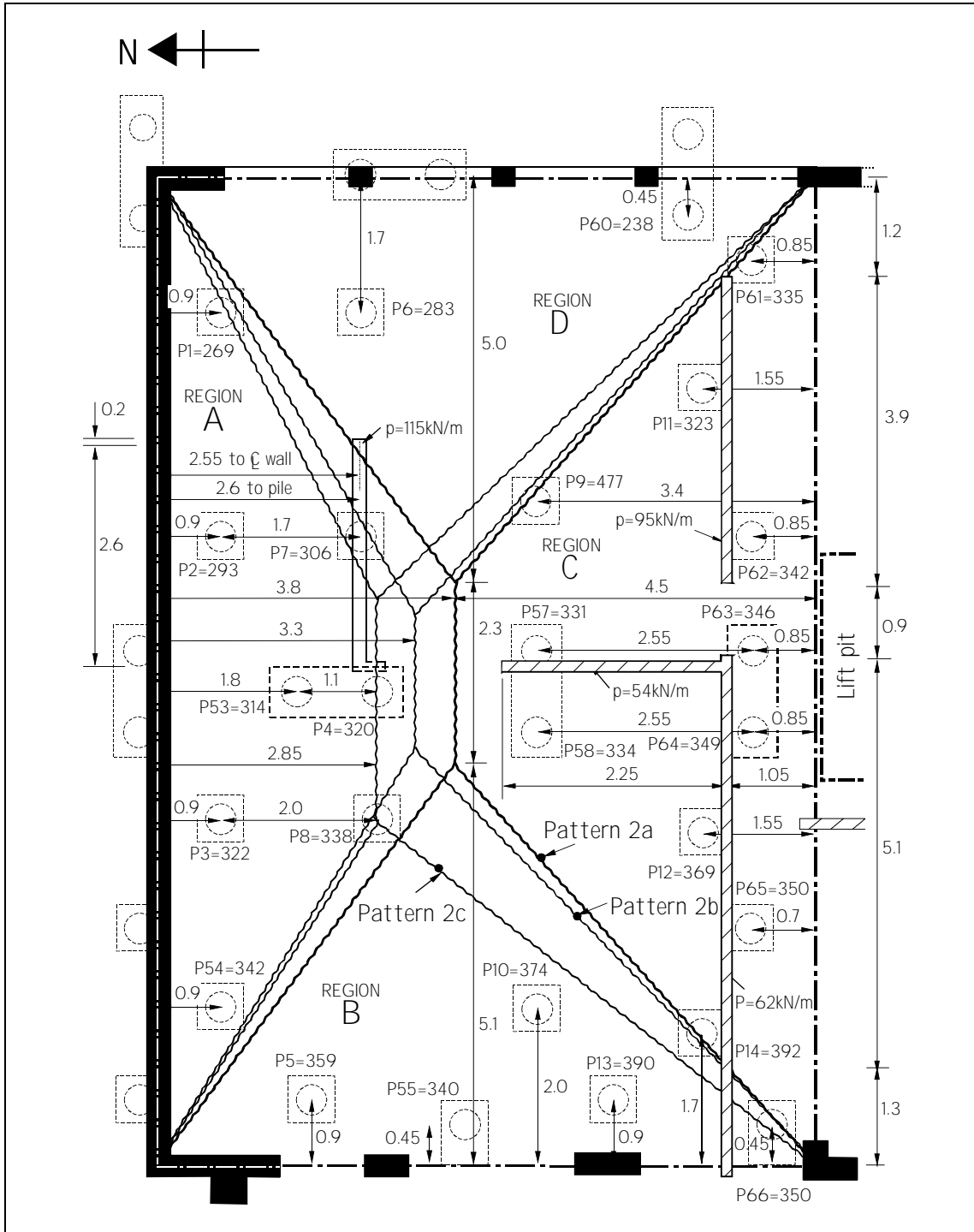
Figure 4.9 shows the plan layout of the basement at raft level. The solidly shaded walls are the walls that continue up the building to support the floors and therefore also provide line support to the raft. The hatched walls support only the ground floor and will therefore form line loads on the raft. Some of the possible failure patterns to be investigated are shown here. By inspection pattern 2 is likely to be critical and details of this area including possible yield line patterns, dimensions and loads in piles and walls are shown in Figure 4.10.

Undertake the analysis and design for pattern 2a.



**Figure 4.9** General arrangement of basement and raft foundation showing possible yield line failure patterns.

*The lift pit was cast monolithically with the raft to ensure the negative yield lines assumed in the analysis were valid.*

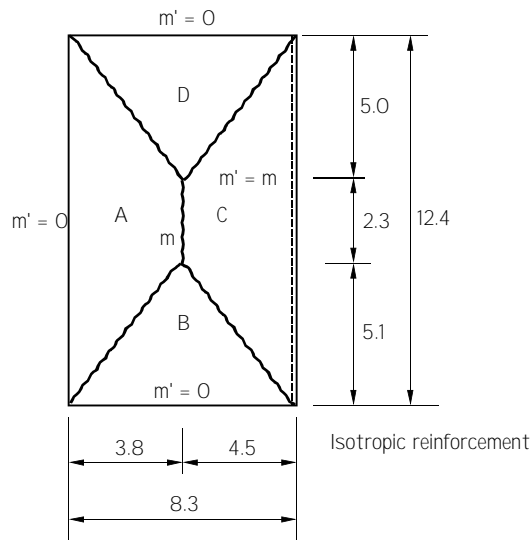


**Figure 4.10** Detailed arrangement of raft with respect to failure pattern 2a

*NB This area enlarged and rotated through 90° with respect to Figure 4.9.*

## Layout

Pattern 2a:



## Data

Raft 600 mm thick slab, self-weight 15 kN/m<sup>2</sup>

Concrete C40. Cover 50 mm T&B

The pile loads shown in Figure 4.10 are working loads derived from the loading imposed on the raft by the super-structure. In the analysis, they are factored by 1.5 to bring them up to ultimate loads.

The line loads shown are also working loads. These and the self-weight of the raft are relieving loads and therefore not factored..

Applying the Work method applied to pattern 2a<sup>uu</sup>

E = Expenditure of external energy by the loads i.e. the summation of ultimate pile loads multiplied by displacement in each region<sup>w</sup>

<sup>uu</sup> If the piles had been evenly spaced at about three diameter centres it would have been possible to work instead with an equivalent uniformly distributed load with little loss of accuracy. Dealing with point loads is labour intensive and requires complete setting out of details in order to evaluate the expenditure of energy for each individual pile. Unfortunately, in this case, circumstances did not permit an even distribution of piles.

<sup>w</sup> In the evaluation of E (expenditure of external energy by the loads) all the piles are multiplied by a factor of 1.5 to convert working loads to ultimate loads. Each pile load is multiplied by the ratio of its distance from the axis of rotation relevant to the region it was in, and to the point of maximum deflection in order to establish its proportion of unit movement.

E =

Region A:

$$1.5 \times 269 \text{ kN} \times 0.9 \times \frac{1}{3.8} = 95.6$$

$$1.5 \times 293 \text{ kN} \times 0.9 \times \frac{1}{3.8} = 104.1$$

$$1.5 \times 322 \text{ kN} \times 0.9 \times \frac{1}{3.8} = 114.4$$

$$1.5 \times 342 \text{ kN} \times 0.9 \times \frac{1}{3.8} = 121.5$$

$$1.5 \times 306 \text{ kN} \times 2.6 \times \frac{1}{3.8} = 314.1$$

$$1.5 \times 388 \text{ kN} \times 2.9 \times \frac{1}{3.8} = 386.9$$

$$1.5 \times 314 \text{ kN} \times 1.8 \times \frac{1}{3.8} = 223.1$$

$$1.5 \times 320 \text{ kN} \times 2.9 \times \frac{1}{3.8} = 366.3$$

+ Region B:

$$1.5 \times 359 \text{ kN} \times 0.9 \times \frac{1}{5.1} = 95.0$$

$$1.5 \times 374 \text{ kN} \times 2.0 \times \frac{1}{5.1} = 220.0$$

$$1.5 \times 390 \text{ kN} \times 0.9 \times \frac{1}{5.1} = 103.2$$

$$1.5 \times 392 \text{ kN} \times 1.7 \times \frac{1}{5.1} = 196.0$$

$$1.5 \times 340 \text{ kN} \times 0.45 \times \frac{1}{5.1} = 45.0$$

$$1.5 \times 350 \text{ kN} \times 0.45 \times \frac{1}{5.1} = 46.3$$

+ Region C:

$$1.5 \times 477 \text{ kN} \times 3.4 \times \frac{1}{4.5} = 540.6$$

$$1.5 \times 323 \text{ kN} \times 1.55 \times \frac{1}{4.5} = 166.9$$

$$1.5 \times 331 \text{ kN} \times 3.4 \times \frac{1}{4.5} = 375.1$$

$$1.5 \times 334 \text{ kN} \times 3.4 \times \frac{1}{4.5} = 378.5$$

$$1.5 \times 335 \text{ kN} \times 0.85 \times \frac{1}{4.5} = 94.9$$

$$1.5 \times 342 \text{ kN} \times 0.85 \times \frac{1}{4.5} = 96.9$$

$$1.5 \times 346 \text{ kN} \times 0.85 \times \frac{1}{4.5} = 98.0$$

$$1.5 \times 349 \text{ kN} \times 0.85 \times \frac{1}{4.5} = 98.9$$

$$1.5 \times 369 \text{ kN} \times 1.55 \times \frac{1}{4.5} = 190.7$$

$$1.5 \times 350 \text{ kN} \times 0.7 \times \frac{1}{4.5} = 81.7$$

+ Region D

$$1.5 \times 283 \text{ kN} \times 1.7 \times \frac{1}{5} = 144.3$$

$$1.5 \times 328 \text{ kN} \times 0.45 \times \frac{1}{5} = 44.3$$

Sum of positive values  $\Sigma = 4742.3$

Uniformly distributed loads<sup>ww</sup>

$$-15 \text{ kN/m}^2 \times 10.1 \times 8.3 \times \frac{1}{3} = -419.2$$

$$-15 \text{ kN/m}^2 \times 12.3 \times 8.3 \times \frac{1}{2} = -143.2$$

- Line loads:  $-115 \text{ kN/m} \times 2.6 \times 2.55 \times \frac{1}{3.8} = -200.6$

$$-62 \text{ kN/m} \times 1.3 \times 0.65 \times \frac{1}{5.1} = -10.3$$

$$-115 \text{ kN/m} \times 0.2 \times 3.2 \times \frac{1}{5} = -14.7$$

$$-54 \text{ kN/m} \times 3.9 \times 2.7 \times \frac{1}{4.5} = -126.6$$

$$-95 \text{ kN/m} \times 3.9 \times 1.15 \times \frac{1}{4.5} = -112.1$$

$$-62 \text{ kN/m} \times 5.1 \times 1.15 \times \frac{1}{4.5} = -95.7$$

$$\text{Sum of negative values } \Sigma = -1122.4$$

$$E = 4742.3 - 1122.4 = 3619.9$$

D =

$$12.4\text{m} \times \frac{1}{3.8} = 3.26\text{m}$$

$$8.3\text{m} \times \frac{1}{5.1} = 1.63\text{m}$$

$$8.3\text{m} \times \frac{1}{5} = 1.66\text{m}$$

$$2 \times 12.4\text{m} \times \frac{1}{4.5} = 5.51\text{m}$$

$$\Sigma = \underline{12.06\text{m}}$$

From D = E we get:

$$12.06\text{m} = 3619.9$$

$$m = \frac{3619.9}{12.06}$$

$$m = \underline{300.16 \text{ kNm/m (for pattern 2a)}}$$

Similar analyses were carried out on patterns 2B and 2C, but pattern 2A was found to be more critical.

<sup>ww</sup> Because the raft is considered to be an inverted slab loaded by the individual piles that produce positive work, all the gravity loading i.e. the self-weight of the raft and the line loads from internal walls, give rise to negative work

Design

Patterns 1 and 3 were analysed in a similar way to give the following results:

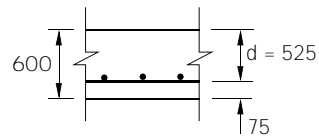
Pattern 1            217.94 kNm/m

Pattern 2a          300.16 kNm/m

Pattern 3            275.62 kNm/m

As pattern 2a is most onerous design raft for<sup>xx</sup>:

$$m = 300.16 \times 1.1 = 330.2 \text{ kNm/m}$$



$$Mbd^2f_{cu} = \frac{330.2 \times 10^6}{10^3 \times 525^2 \times 40} = 0.03 \quad \therefore z = 0.95d$$

$$A_{s \text{ req}} = \frac{330.2}{0.95 \times 0.525 \times 0.438} = 1512 \text{ mm}^2 / \text{m}$$

Provide T25 @250 cc (1964 mm<sup>2</sup>/m) each way T&B through

<sup>xx</sup> As described earlier it is usual to increase moments by 10% to allow for an adverse pattern forming, etc.



## 4.7 Refurbishments

Yield Line Theory can be employed very successfully whenever alterations to existing reinforced concrete floor slabs are contemplated. In essence, the Work method of analysis is applied in the usual way. Whenever a new use is required the main question that arises is "What is the load capacity of the new slab"? However, as the moment capacity of the existing slab is known, or can be determined from drawings, surveys and /or investigations, the unknown, to be determined by calculation, becomes the load capacity.

Once a failure pattern has been postulated, the Work Method is used. The external energy expended,  $E$ , becomes a function of the ultimate load the floor can sustain. The dissipation of internal energy,  $D$ , is based on the ultimate moments of resistance of the slab. The method can be used to determine load capacity, or spare load capacity, of a slab in both its existing state and its proposed new state.

Ideally, general arrangement and reinforcement detail drawings of existing slabs will be available. If this information is not available or if there is concern about the reliability of the record drawings, then surveys, reinforcement surveys using cover meters, and investigations, such as uncovering reinforcement or taking cores, can be made to verify or establish size, type and spacing of reinforcement and concrete strength.

### 4.7.1 Holes

One of the most common requirements of refurbishment works is the requirement to cut holes in existing slabs. Holes tend to attract yield lines.

When investigating such a slab, it is best to first draw the failure pattern assuming that the hole has no influence on the shape and geometry of the pattern. Then the pattern is moved towards the hole ensuring that none of the basic rules associated with the forming of failure patterns as set out in Section 2.2.6 are violated.

Care has to be exercised when evaluating the dissipation of energy along the yield lines when assessing the contribution of the reinforcement crossing the yield line near the hole. Where bars have been cut and the anchorage is less than full, the bars cannot contribute fully to the calculated moment capacity. These bars are best ignored in the calculations and this is most easily achieved by assuming the affected length of yield line in the relevant direction has zero strength.

Edges of holes can also attract line loads from stairs or partitions, etc. In the case of a new opening being formed for a stair, the reaction of the flights will impose a line load on one side of the opening. This line load has to be taken into account when working out the expenditure of external loads.

In this context it has to be said that small isolated holes for pipework etc. are usually ignored, as they are not large enough to attract yield lines. If, however, they happen to be situated in the natural path of a yield line then, when evaluating the dissipation of internal energy along that yield line, the length of line must be reduced by the hole dimension.

### Example 4G

#### Hole in two-way slab using the Work Method

An existing 250 mm thick concrete slab measuring 7.0 x 9.0 m is simply supported on all four sides and is to have a hole 2.0 x 2.0 m formed at the location shown in Figure 4.11. It carries finishes weighing 1.5 kN/m<sup>2</sup>. The concrete has been established as being C30 and drawings show that the reinforcement in the shorter direction consists of T12 @ 150 cc bottom and T12 @ 300 cc in the other direction. The cover is 20 mm.

The task is to establish what live load the slab with the hole can safely sustain.

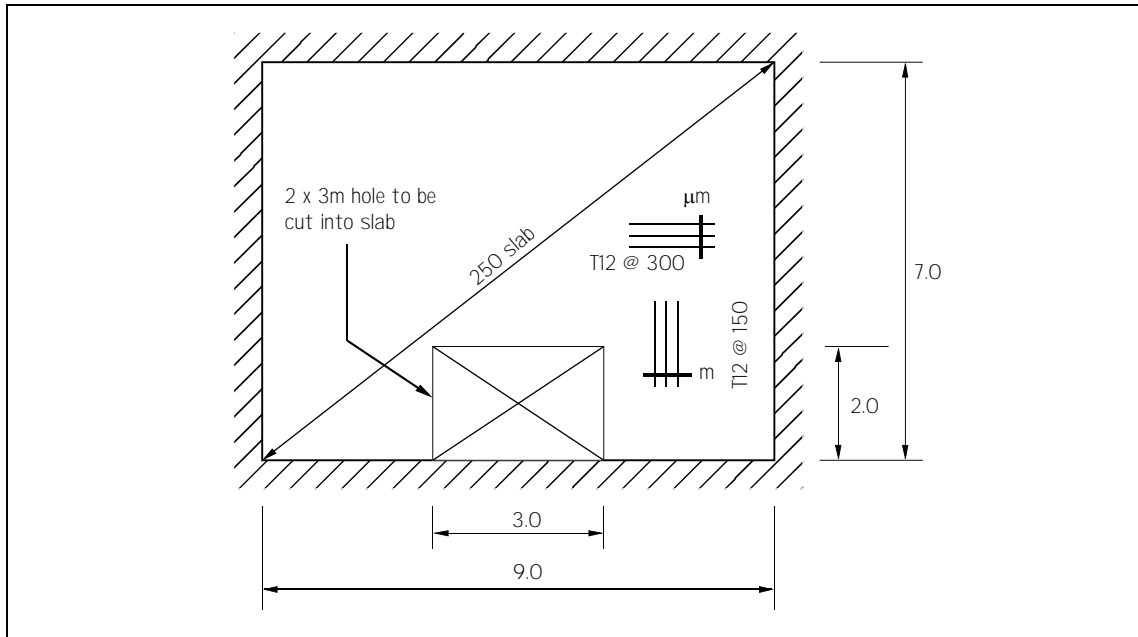


Figure 4.11 General arrangement of existing slab with proposed hole

#### Layout

For layout see Figure 4.11 for details

#### Parameters

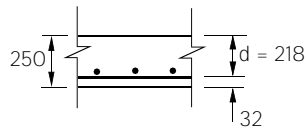
##### LOADING:

Dead load: 250 slab  $0.25 \times 24 = 6.0$

Finishes  $= 1.5$

$\overline{7.5 \text{ kN/m}^2}$

##### Moment of resistance:



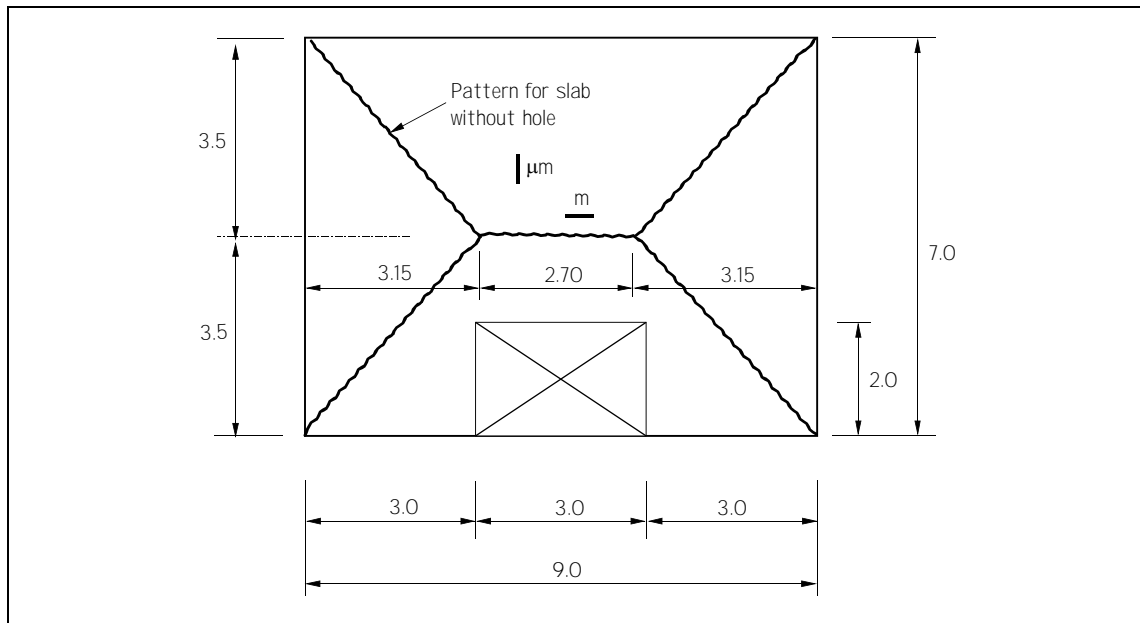
$d_{ave} = 250 - 20 - say 12 = 218$

T12 @ 150 cc:  $m = 754 \times 0.95 \times 0.218 \times 0.438 =$

$\underline{m = 68.4 \text{ kNm/m}}$

T12 @ 300 cc:

$\mu m = 377 \times 0.95 \times 0.218 \times 0.438 = 34.2 \text{ kNm/m}$



**Figure 4.12** Possible failure pattern ignoring hole

1) Establish 'n' for original slab

With reference to Figure 4.12:

E =

$$n \text{ kN/m}^2 \times 6.3 \times 7 \times \frac{1}{3} = 14.7n$$

$$n \text{ kN/m}^2 \times 2.7 \times 7 \times \frac{1}{2} = 9.45n$$

$$\Sigma = 24.15n$$

D =

$$2 \times 9 \text{ m} \times \frac{1}{3.5} = 5.14 \text{ m}$$

$$2 \times 7 \text{ m} \times \frac{1}{3.15} = 4.44 \text{ m}$$

i.e

$$5.14 \times 68.4 = 351.6$$

$$4.44 \times 34.2 = 151.8$$

$$\Sigma = 503.4$$

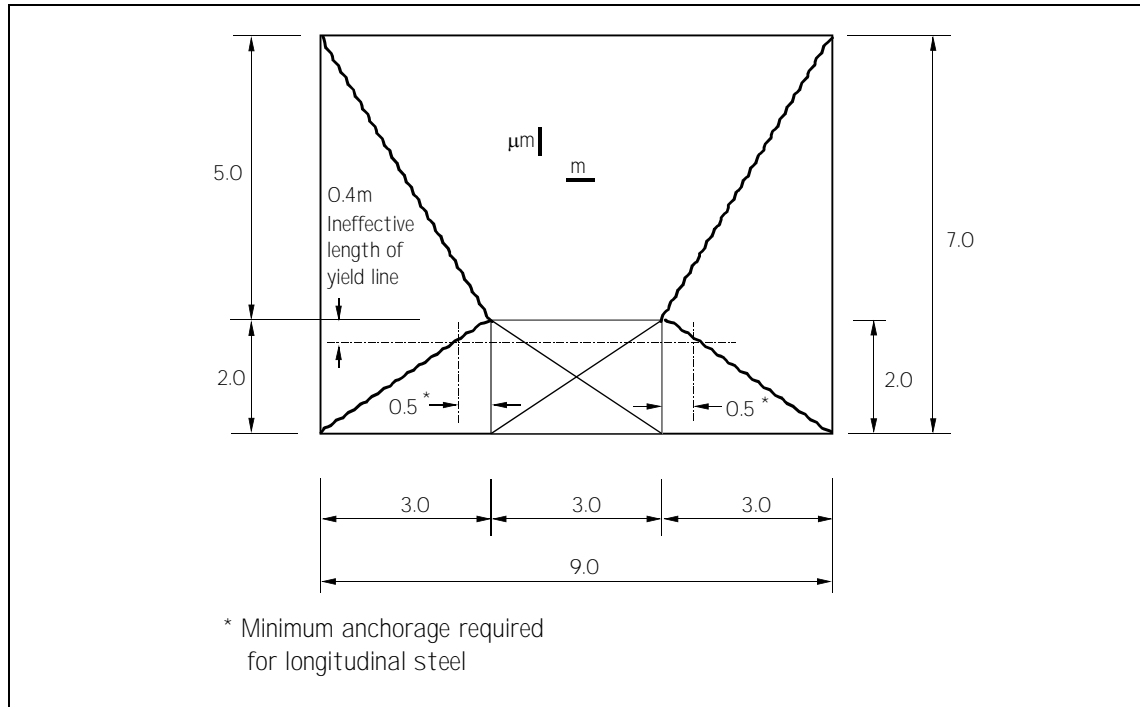
From D = E we get:

$$24.15 n = 503.4$$

$$n = \frac{503.4}{24.15} = 20.8 \text{ kN/m}^2$$

For this crack pattern the hole does not interfere with the Yield Lines. So 'n' does not change<sup>yy</sup>.

<sup>yy</sup> If  $g_k = 0.25 \times 24 + 1.5 = 7.5$ , and no adverse pattern factor, then  $p_{\text{allowable}} = (20.8 - 7.5 \times 1.4) / 1.6 = 6.43 \text{ kN/m}^2$



**Figure 4.13** Possible failure pattern with hole

The pattern in Figure 4.12 has been 'attracted' to the hole.

2) Establish 'n' when pattern is drawn towards the hole:

With reference to Figure 4.13:

E =

$$n \times 6 \times 7^{ZZ} \times \frac{1}{3} = 14.0n$$

$$n \times 3 \times 7^{AAA} \times \frac{1}{2} = 10.5n$$

$$\Sigma = 24.5n$$

D =

$$2 \times 6.6^{BBB} \mu m \times \frac{1}{3} = 4.4 \mu m$$

$$1 \times 6m \times \frac{1}{5} = 1.2m$$

$$1 \times 6m \times \frac{1}{2} = 3.0m$$

From E = D we get:

$$\begin{aligned} 24.5 n &= 4.4 \mu m + 4.2m \\ &= 4.4 \times 34.2 + 4.2 \times 68.4 \\ &= 437.8 \end{aligned}$$

<sup>ZZ</sup> The area of the hole has been included. The reason for including the load within the hole area is that any future reinstatement would not alter the slab capacity.

<sup>AAA</sup> The area of the hole has been included. The reason for including the load within the hole area is that any future reinstatement would not alter the slab capacity.

<sup>BBB</sup> As the yield line gets close to the hole, the reinforcement in the  $\mu m$  direction has incomplete anchorage. Therefore an allowance is made for what is assumed to be an ineffective length of yield line.

$$\text{Thus } n = \frac{437.8}{24.5} = 17.9 \text{ kN/m}^2$$

i.e. this pattern has a lower failure load.

Applying the 10% rule for an adverse pattern forming the allowable design load is  $17.9/1.1 \approx 16.3 \text{ kN/m}^2$

$$\text{As } n = 1.4 \times g + 1.6 \times p$$

$$16.3 = 1.4 \times 7.5 + 1.6 \times p$$

$$p = \frac{16.3 - 1.4 \times 7.5}{1.6} = 3.625 \text{ kN/m}^2$$

The slab with the hole can sustain a live load of 3.625 kN/m<sup>2</sup>

### Commentary on calculations

By moving the crack pattern towards the hole, as shown in Figure 4.13, there has been a reduction from 20.8 to 17.9 kN/m<sup>2</sup> (14%) in the failure load. This is a comparatively small price to pay for accommodating a hole of this size.

It is usual not to subtract the load over the hole in case it is filled in again some time in the future.

# I

## 5.0 Case studies

### One Warrington Gardens, London W9



**Figure 5.1** *This is a multi-storey block of luxury flats with two levels of basement car parking.*

*There are eight large flats to each floor varying in size and plan shape.*

*In order to give the architect complete freedom in the layout of each flat, r.c. blade columns were hidden within the dividing walls. This produced an irregular layout of supports for the r.c. flat slab floor that was 250 mm thick with spans in the order of 8 m. Yield Line theory was used to design these floors. Care was taken to locate the columns in positions to promote two-way modes of failure so as to reduce design moments and deflections.*

*Yield Line Theory was also used for the design of the transfer slab at ground floor level and the folded plate ground bearing raft foundation.*

*Client: Pal Properties Ltd.*

*Contractor: Wiltshier Construction (London) Ltd.*

## 43-47 St John's Wood Road, London NW8



**Figure 5.2** *When first conceived these luxury flats had no engineering input and a column layout had to be found that was in sympathy with the dividing walls and partitions at all levels. This resulted in a very irregular layout of blade columns concealed in the walls in order not to project into the usable areas. A solid 250 mm thick reinforced concrete flat slab was chosen to deal with the varying spans and large semi-circular balconies projecting over 2 m beyond the face of the building.*

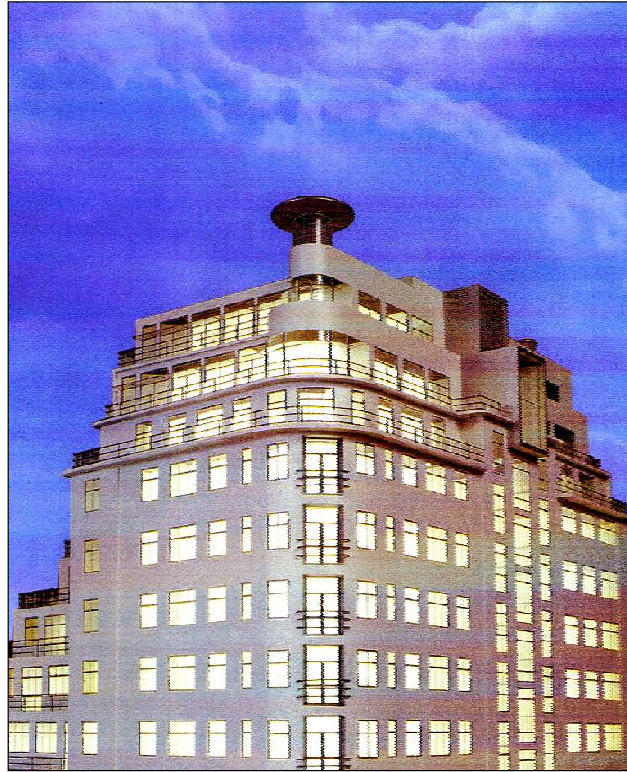
*The slabs in the superstructure, the transfer slabs and the raft foundation were all designed using Yield Line Theory. The flat slab philosophy enabled the contractor to use very simple formwork on a repetitive basis.*

*Client: Pal Properties Ltd.*

*Contractor: Wiltshier Construction(London) Ltd.*

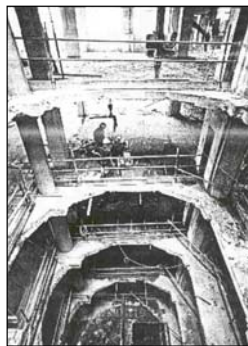


## Onslow House, Saffron Hill, London EC1



**Figure 5.3** This project was a major refurbishment of a reinforced concrete framed warehouse building that dates back to 1933. It featured flat slab construction with drops and mushroom heads to columns.

For the conversion to luxury flats, extensive alterations were required in the form of cutting new openings, cutting away existing shaft walls and filling in the redundant holes. Yield Line Theory was used to assess the capacity of the floor to take new loads and take account of new openings. Its use led to considerable savings in cost and time compared with design using more conventional methods.



The original budgets had envisaged the need to break out and recast large areas of slab. However, this proved unnecessary as the yield line analysis showed adequate reserves of strength to incorporate the vast majority of the required changes.

Three storeys were added to the top of the building. The columns in the extension are supported on a transfer slab that was cast using the existing roof slab as permanent formwork. The design of the transfer slab and the flat slabs to this addition was also carried out using Yield Line Theory.



Yield Line design was used to demonstrate that the raft foundations could accommodate both the major refurbishment and the three-storey extension without any alterations to the foundations whatsoever.

Client:  
Contractor

Loft Ltd.  
Sindall Construction Ltd.



## Nokia Headquarters, Stanhope Road, Camberley



**Figure 5.4** *This project was constructed as the European Headquarters and central hub for Nokia. The building is a three-storey structure with two suspended reinforced concrete floors, covering a plan area of 54 by 54 metres. The columns are on a grid of approximately 9.5 m by 9.5 m supporting an r.c. waffle floor slab 450 mm deep overall.*

*The slab was designed as a flat slab structure using the Yield Line Theory. Solid areas were formed at column locations to accommodate top steel concentrations for the negative moments and for punching shear considerations.*

*Straight-line failure patterns were considered in both directions and the local failure patterns were used to design the reinforcement at perimeter supports and as a check against a local failure occurring at internal supports.*

*Client: Nokia plc.  
Contractor: Byrne Bros. Ltd.*

## East India Dock Redevelopment



**Figure 5.5** *Four office blocks of 8 to 11 storeys make up this 1 million square feet development in London's Docklands. All the buildings consist of an in-situ concrete frame made up of a flat slab and columns.*



*Yield Line Theory was used throughout in the design of the flat slabs. Due to the simplicity of the reinforcement layouts and the amount of repetition of bar lengths the contractor was able to use purpose-made mesh sheets made from high yield reinforcement to his advantage and thereby save time on the critical path.*

*Some 55,000 cubic metres of concrete and 7,500 tonnes of reinforcement were used.*

*Client: NCC Property Ltd.  
Contractor Birse Construction Ltd.*

## 66 Buckingham Gate, London SW1



**Figure 5.6** *This £5 million project was located on a city centre triangular shaped site with two sides adjacent to busy London streets. The proposal called for a multi-storey office complex plus a two-level basement structure. Yield Line analysis was used extensively in the design of the triangular in-situ concrete flat slabs, together with the raft foundation.*

*The thin solid concrete slabs with no downstands gave the greatest possible freedom of movement for services and were particularly helpful to the architect in complying with the onerous conditions imposed by the Planning Authorities on building heights.*

*To assist fast construction on this congested site prefabricated reinforcement cages and mats were extensively used.*

*Client: Charter Group Developments plc.  
Contractor Alfred McAlpine Construction Ltd.*

## 80 Oxford Road, High Wycombe



**Figure 5.7** This prestigious commercial development incorporated the construction of a multi-storey office block with a link to a separate multi-storey car park. Yield Line Design was used for the flat slabs used in both of these blocks.

*Yield Line Design is particularly suited to rationalised methods of reinforcing slabs. The reinforcement for this design was achieved by using the Bamtec System. This involves prefabricating one-way mats of reinforcement, which are rolled out into position like a carpet in each direction. Loose bars are then added to fill any gaps that might occur. The contractor chose the system to speed up the construction cycle.*

*Client: Salmon Developments Ltd.  
Contractor: Dove Bros / O'Rourke.*

## 6.0 Summary

Yield Line Design is a robust and proven design technique. It is a powerful and versatile and challenges structural designers to use their skill and judgement. Whilst some of the terms and ideas may at first be unfamiliar, the rewards are simple, engineered designs that benefit everyone in the supply chain.

Yield Line design leads to least cost, least weight, best value solutions – and great opportunities.

# 7.0 References & further reading

## 7.1 References

- 1 GOODCHILD, C. H. *Rationalisation of flat slab reinforcement*. Crowthorne, British Cement Association. 2000. Ref. 97.376. 210 pp.
- 2 EUROPEAN CONCRETE COMMITTEE. *Bulletin D'information No. 35*. (Information Bulletin No 35: *The application of the yield line theory to calculations of the flexural strength of slabs and flat slab floors*) Translated by C. V. Amerongen. London, Cement And Concrete Association, 1962. 180 pp.
- 3 BRITISH STANDARDS INSTITUTION. Eurocode 2: *Design of concrete structures – part 1: general rules and rules for buildings*. prEN 1992-1-1 (Draft for stage 49) July 2002, London, BSI.
- 4 EGAN, J (Chairman). *Rethinking construction.*, London, The Stationary Office, 1998. 40 pp.
- 5 JOHANSEN, K. W. *Brudlinieteorier*. Jul. Gjellerups Forlag, Copenhagen, 1943, 191pp. (*Yield Line theory*, Translated by Cement and Concrete Association, London, 1962. 181 pp.)
- 6 JOHANSEN, K. W. *Pladeformler*. Polyteknisk Forlag, Copenhagen, 1968, pp 240 (*Yield line formulae for slabs*, Translated by Cement and Concrete Association, London, 1972. Ref 12.044. 106 pp.).
- 7 BRITISH STANDARDS INSTITUTION. BS 8110: Part 1 1997. *Structural use of concrete, Part 1. Code of practice for design and construction*, London, BSI.
- 8 THE CONCRETE SOCIETY *Deflection of concrete slabs and beams*. Draft report of Working Party, November 2001. Crowthorne.
- 9 BARRATT S. Verulam *The Structural Engineer*, 3 July 2001. Vol. 79, No. 12. p. 23.
- 10 GILBERT, R. I. Effect of reinforcement distribution on the serviceability of reinforced flat slabs, 9<sup>th</sup> *Australian Conference on the Mechanics of Structures and Materials*, 29 - 31 August 1984, University Of Sydney, 1984. pp. 210 - 214.
- 11 PARK, R. & GAMBLE, W. L. *Reinforced concrete slabs*. New York, John Wiley & Sons, 1980, 618 pp.
- 12 BRITISH CEMENT ASSOCIATION. *Assessment of the ductility requirements for cold-worked reinforcement* – BCA Engineering Division Internal Report, 1995,
- 13 WOOD, R. H. *Plastic and elastic design of slabs and plates with particular reference to reinforced concrete floor slabs*. London, Thames and Hudson, 1961. 344 pp.
- 14 JONES, L. L. & WOOD, R. H. *Yield-Line analysis of slabs*. London, Thames and Hudson, 1967. 405 pp.
- 15 INGERSLEV, A. The strength of rectangular slabs. *J. Inst. Struct. Eng.* Vol. 1, No. 1, January 1923. pp. 3 - 14.
- 16 JONES, L. L. Ultimate load analysis of reinforced and prestressed concrete structures. London, Chatto & Windus, 1962. 248 pp.
- 17 SAWCZUK, A. & JAEGER, T. *Grenztragfähigkeits-Theorie Der Platten*. Berlin, Springer-Verlag, 1963. 522 pp.

- 18 KEMP, K. O. The yield criterion for orthotropically reinforced concrete slabs. *International Journal Mech. Sci.*, Pergamon, 1965, Vol 7. pp. 737 - 746.
- 19 MORLEY, C. T. On the yield criterion of an orthogonally reinforced concrete slab element. *Journal Mech. Phys. Solids*, Vol. 14. pp. 33 - 47.
- 20 KWIECINSKI, M. *Collapse load design of slab-beam systems*. Chichester, Ellis Horwood Ltd, 1989. 251 pp.
- 21 HAYES, B., TAYLOR, R. Some tests on reinforced concrete beam-slab panels. *Mag. Concr. Res.*, Vol. 21, No. 67, June 1969. pp.113 - 120.
- 22 PARK, R. The behaviour of a model slab and beam floor designed by limit design. *Civ. Eng. Trans. Eng., Aust.*, CE 12, No. 1, April 1970. pp. 1 - 6.
- 23 HATCHER, D. S., SOZEN M. A., & SIESS, C. P. Test of a reinforced concrete flat slab. *J. Struct. Div., ASCE*, Vol. 95, No. ST6, June 1969. pp. 1051 - 1072.
- 24 GAMBLE, W. L., SOZEN, & M. A., SIESS, C. P. Tests of a two-way reinforced concrete slab. *J. Struct. Div., ASCE*, Vol. 95, No. ST6, June 1969. pp. 1073 - 1096.
- 25 CARDENAS, A. E., & KAAR, P.H. Field test of a flat plate structure. *Proc. ACI*, Vol. 68, January 1971. pp. 50 - 59.
- 26 THE CONCRETE SOCIETY. *Concrete industrial ground floors: a guide to their design and construction*. Concrete Society Technical Report 34. Slough, The Concrete Society, 1994. 148 pp.
- 27 TOMLINSON, M. J. *Foundation design and construction*, 4<sup>th</sup> edition, London, Pitman, 1982, 793 pp.
- 28 BOWLES, J. E. *Foundation analysis and design*, 3<sup>rd</sup> edition, Singapore, McGraw-Hill, 1984. 816 pp.
- 29 REYNOLDS C. E. & STEEDMAN J. C. *Reinforced concrete designer's handbook*, 10<sup>th</sup> Edition, 1988, London, Spon, 436 pp.
- 30 BRITISH STANDARDS INSTITUTION. *Eurocode 0: Basis of structural design* BS EN 1990, 2002, London, BSI.
- 31 BRITISH STANDARDS INSTITUTION. BS 8110 Part 2 1985, *Structural use of concrete, Part 2. Code of practice for special circumstances*, London, BSI.
- 32 THE CONCRETE SOCIETY. *Design guidance for high strength concrete*, Concrete Society Technical Report 49. Slough. The Concrete Society, 1998, 168 pp.
- 33 ACI COMMITTEE 363, State-of-the-art report on high strength concrete, *ACI Journal, Proceedings*, Vol. 81 No. 4 July/August 1984. pp. 364 - 411.
- 34 BECKETT, D. Concrete industrial ground slabs. *Design application of raft foundations*. Edited by J. A. Hemsley. London, Thomas Telford, 2000. pp. 1 - 38.
- 35 MIDDLETON, C.R. Concrete bridge assessment: an alternative approach. *The Structural Engineer*, Vol. 75, Nos. 23 & 24, Dec. 1997. pp. 403 - 409.
- 36 CLARK, L. A. *Collapse analysis of short to medium span concrete bridges*. Transport and Road Research Laboratory, Crowthorne, 1984. 195 pp.
- 37 KEMP K.O., MORLEY C.T., NIELSEN M.P., WOOD R.H. & JONES L.L. *Recent developments in Yield-Line theory*, MCR Special Publication, May 1965, Slough, Cement & Concrete Association. 74 pp.
- 38 WHITTLE, R.T. *Design of reinforced concrete flat slabs to BS 8110*, CIRIA Report 110, 1985. 48 pp.
- 39 MEYERHOF G.G. Load-carrying capacity of concrete pavements, *Journal of the Soil Mechanics and Foundations division, Proceedings of the American Society of Civil Engineers*, Vol.88, No. SM 3, June 1962. pp. 89 - 116.

- 40 LOSBERG A. Pavements and slabs on grade with structurally active reinforcement. *American Concrete Institute Journal*, Vol. 75, No. 11, Nov. 1978. pp. 647 - 657.
- 41 BAUMANN R.A. & Weisgerber F.E., Yield-line analysis of slabs-on-grade. *Journal of Structural Engineering, ASCE*, Vol. 109, No. 7, July 1983. pp. 1553 - 1568.
- 42 VSL INTERNATIONAL LTD, *Post-tensioned slabs*, Berne, January 1985.
- 43 BRITISH STANDARDS INSTITUTION. BS 5628, 1978, *Code of practice for use of masonry, Part 1, Structural use of unreinforced masonry*, London, 1992.
- 44 GESUND, H. & KAUSHIK, Y.P. Yield line analysis of punching failures in slabs, *International Association for Bridge and Structural Engineering*, V30 I. pp. 41 - 60, Zurich, 1970.
- 45 GESUND, H. & DIKSHIT, O.P, Yield line analysis of the punching problem at slab/column intersections, *Symposium – Concrete slab systems*, Paper SP 30-8, pp 177 - 201, Zurich, 1970.
- 46 MORLEY, C.T. personal correspondence, September 2002.
- 47 JOHNSON, D. Mechanism determination by automated yield-line analysis. *The Structural Engineer*, Vol 72, No. 19, 1994, pp. 323 - 327.
- 48 JOHNSON, D. Lower bound collapse analysis of concrete slabs, *Proc. Concrete Communication Conference* (held at the University of Cardiff, July 1999) BCA, Crowthorne, 1999. pp. 299 - 310.
- 49 CHANA, P.S., & DESAI S. B. Membrane action, and design against punching shear, *The Structural Engineer*, Vol. 70, no. 19, 6 October 1992. pp. 339 - 343.
- 50 REGAN, P.E. *Behaviour of reinforced concrete flat slabs*. CIRIA Report 89, 1981. 90 pp.

## 7.2 Further reading

### 7.2.1 Recommended reading

Those who are interested in a deeper understanding of Yield Line theory and its application are directed towards references 5, 6 and especially reference 14 above. Recommendations for more specialist reading are as follows:

#### Balcony slabs

CHU, K. H. & SINGH, R.B. Yield analysis of balcony floor slabs. *Journal of The American Concrete Institute*, May 1966, pp. 571 - 586.

#### Flat slabs

*Bulletin d'Information No. 35* English Translation, March 1962, pp. 42 - 44.

SIMMONDS, S. H. & GHALI, A. Yield-line design of slabs. *Journal of The Structural Division, ASCE*, Vol. 102, No. ST1, Jan 1976, pp. 109 - 123.

#### Slab-beam structures

PARK, R. Limit designs of beams for two-way reinforced concrete slabs. *Structural Engineer*, Sept. 1968, Vol. 46, No. 9, pp. 269 - 274.



PARK, R. Some irregular cases of beam loading in limit design of slab and beam floors. *Structural Engineer*, Jan 1970, Vol. 48, No. 1, pp. 17 - 19.

#### **Slabs on ground**

MEYERHOF, G. G. Load-carrying capacity of concrete pavements. *Journal of the soil mechanics and Foundations Division, ASCE*, Vol. 88, No. SM3, June 1962, pp. 89 - 116.

MEYERHOF, G. G. & SUBBA RAO, K. S. Collapse load of reinforced concrete footings. *Journal of the Structural Division, ASCE*, Vol. 100, No. ST5, pp. 1001 - 1018.

#### **Slabs with holes**

ZASLAVSKY, A. Yield line analysis of rectangular slabs with central openings. *ACI Journal*, Dec. 1967, pp. 838 - 844.

ISLAM, S. & PARK, R. Yield-line analysis of two-way reinforced concrete slabs with openings. *The Structural Engineer*, Vol. 49, No. 6, pp. 269 - 276.

#### **Slabs**

DUTCH COMMITTEE FOR CONCRETE RESEARCH C. U. R. *Report No. 26A, the analysis of slabs by the yield-line theory*. Translation No. 135, Cement and Concrete Association, London, 1962, 36 pp.

DUTCH COMMITTEE FOR CONCRETE RESEARCH C. U. R. *Report No. 26B Experimental investigation of the plastic behaviour of slabs*, Translation No. 136, Cement And Concrete Association, London, 1963, 35 pp.

DUTCH COMMITTEE FOR CONCRETE RESEARCH C. U. R. *Report No. 26C Examples of slab design by the yield-line theory*. Translation No. 121, Cement and Concrete Association, London, 1965, 116 pp.

EUROPEAN CONCRETE COMMITTEE. *Bulletin D'information No. 27*. (Information Bulletin No 27). Paris, 1960, 88 pp.

#### **Bridges**

CLARK, L. A. *Collapse analysis of short to medium span concrete bridges*. Crowthorne, Transport and Road Research Laboratory, 1984. 195 pp.

MIDDLETON, C.R. Concrete bridge assessment: an alternative approach. *The Structural Engineer*, Vol. 75. Nos. 23 & 24, Dec. 1997. pp. 403 - 409

#### **Masonry**

BRITISH STANDARDS INSTITUTION. BS 5628: Part 1: 1978 *Code of Practice for use of masonry*, Part 1: 1992, *Structural use of unreinforced masonry*. London, BSI.

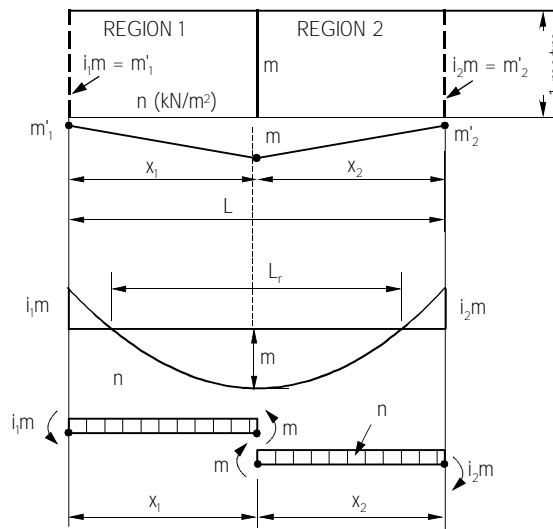
# Appendix

## Proof of formula

In Table 3.1, One-way spanning slabs, the following standard formula appears:

$$m = \frac{nL^2}{2(\sqrt{1+i_1} + \sqrt{1+i_2})^2}$$

It is the basis for all the cases in Table 3.1 and may be proved from first principles using the Equilibrium method as follows:



$L_r$  is the so called 'reduced span' of a simply supported slab giving the same span moment  $m$  as the continuous slab.

We can then write:

$$m = \frac{nL_r^2}{8} \text{ ie}$$

$$n = \frac{8m}{L_r^2}$$

For Region 1 we get:

$$\text{Moment of external loads about support:} = nx_1^2 / 2$$

$$\text{Sum of the moments in the yield lines:} = m + m_1'$$

$$\text{Equilibrium gives:} \quad m + m_1' = nx_1^2 / 2$$

$$= 8mx_1^2 / (2L_r^2)$$

$$\text{therefore} \quad m + i_1 m_1' = 4mx_1^2 / L_r^2$$

$$\text{so} \quad L_r^2 (1 + i_1) = 4x_1^2$$

$$\text{And} \quad L_r \sqrt{1 + i_1} = 2x_1$$

Similarly for region 2 we get:  $L_r \sqrt{1+i_2} = 2x_2$

But  $2x_1 + 2x_2 = 2L$

so  $2L = L_r \sqrt{1+i_1} + L_r \sqrt{1+i_2}$

&  $= L_r (\sqrt{1+i_1} + \sqrt{1+i_2})$

$$\therefore L_r = \frac{2L}{\sqrt{1+i_1} + \sqrt{1+i_2}}$$

As

$$\begin{aligned} m &= \frac{nL_r^2}{8} \\ &= \frac{n4L^2}{8(\sqrt{1+i_1} + \sqrt{1+i_2})^2} \\ &= \frac{nL^2}{2(\sqrt{1+i_1} + \sqrt{1+i_2})^2} \end{aligned}$$

## Other methods

Besides the Work Method and formulae given in this publication, there are several ways to apply Yield Line Theory:

### The Equilibrium Method of analysis

This method of analysis is really the Work Method presented in another form. Its principal use is in combination with the Work Method to show the designer which way to move the chosen layout of a valid yield line pattern in order to get closer to the correct solution.

In the Work Method, the work equation encompasses the whole slab giving a single value for the moment in the slab. The Equilibrium Method investigates each region independently and separate values of moment for each region are obtained. The designer can deduce from these values which way to move the yield line pattern in order to make the values equal and find the yield line solution. When the values are equal the Work and the Equilibrium Methods give identical results.

**Example A1**

$n = 20\text{kN/m}^2$   
 $i = 1$

Panel A  $D = E$

$$2 \times 7.5 m = n \times (7.5 \times 5.0 / 2) \times 5.0 / 3$$

$$15m = 31.25n$$

$$m = 2.08n$$

Panel B

$$9.0m = n \times \left[ \frac{5}{2} \times \frac{3^2}{3} + 1 \times \frac{3^2}{2} + \frac{3}{2} \times \frac{3^2}{3} \right]$$

$$m = 1.83n$$

Panel C

$$7.5m = n \times \frac{7.5}{2} \times \frac{3^2}{3}$$

$$m = 1.50n$$

Panel D

$$2 \times 9.0m = n \times \left[ \frac{5}{2} \times \frac{4.5^2}{3} + 1 \times \frac{4.5^2}{2} + \frac{3}{2} \times \frac{4.5^2}{3} \right]$$

$$m = 2.06n$$

For the exact solution, all panels should balance. In a second iteration, panels A and D would need to be slightly reduced. However if the variation is less than 20% then a mean can be taken.

Mean  $m = 1.87n$

Therefore  $m = 1.87 \times 20 \text{ kN/m}^2 = 37.4 \text{ kNm/m}$

This compares to the solution of  $m = 36.93 \text{ kNm/m}$  in Example 2A and  $m = 38.1 \text{ kNm/m}$  using the exact method and formulae.

The Equilibrium Method considers nodal forces at the junction of yield lines or slab edges to maintain equilibrium of regions with the externally applied loads and the moments along yield lines. It is beyond the scope of this publication to go into any more detail about the application of this method of analysis. The interested reader is referred to Wood & Jones [14] for a detailed coverage of the subject and to Kemp, Morley, Neilsen, Wood & Jones [37] for further developments in this field.

### Hodograph method [46]

Energy dissipated is evaluated by projecting the yield line in turn onto lines perpendicular to the reinforcement. The energy dissipated is:

$$\Sigma(\text{moment/unit width} \\ \times \text{projected length of the yield line} \\ \times \text{projected rotation in the line considered})$$

for all yield lines and for all sets of reinforcement. Energy expended is  $\Sigma(\text{load} \times \text{distance moved})$

Although this method is often analogous to projecting onto axes of rotation, it benefits from being able to deal with orthotropic reinforcement, skew reinforcement and several layers or directions of reinforcement without special measures such as affine transformations. It depends on having low areas of reinforcement.

The solution may be checked by drawing vectors, indicating moment, length and direction, in a hodograph and ensuring that the vectors close.

### Automated Yield Line Design

Automated yield line design may be accomplished by using a triangulated mesh, where the sides of the triangular areas are treated as potential yield lines [47]. The laws of equilibrium are used to relate the moment along each edge to the applied loading. The edge moments are also prevented from exceeding the plastic moment of resistance in either hogging or sagging. The load factor (or resistance moment) and yield pattern by which the slab will collapse may then be obtained by employing the equilibrium and yield constraints in conjunction with an iterative technique known as linear programming. The technique is ideally suited to computer application and can readily accommodate non-uniform loading or reinforcement arrangements.

If the moments at the nodes of the triangular mesh are taken as the unknowns, and it is assumed that moments vary linearly over each triangle, then it follows that the nodal moments will be peak values. By restricting these nodal moments to be below the plastic moment of resistance, and again adding equilibrium conditions, the linear programming technique will now produce a lower bound solution [48]. This compliments the upper bound result obtained from the edge moment type of approach. A lower bound solution has the advantage of being safe, although it may be rather conservative on occasion and does not result in a yield line pattern. A contour plot of the predicted collapse mode may, however, be generated.

The upper and lower bound automated methods have been applied to Examples 3E, 3F, 3G, 4D, 4F and 4G. In each case, the upper and lower bound solutions were either side of the values derived from the hand methods given in this publication. The average spread between the upper and lower bound resistance moments generated was 16% with a greatest spread of 20% and a lowest of 6%.

## Isotropy: moment capacity and orientation of reinforcement

With isotropic slabs, provided the reinforcement in the two directions are at right-angles, the moment capacities in the slab are the same no matter what the orientation of the bars, or direction considered.

This is borne out by the relationship between two sets of bars at right-angles in the 'x' and 'y' directions, crossing a yield line which is at an angle  $\phi$  with one of the bar directions. If

we attribute the value  $m_x$  to the bars in the 'x' direction and  $m_y$  to the bars in the 'y' direction, then the value  $m_n$  of the bars crossing the yield line at right-angles will be :

$$m_n = m_x \cos^2\phi + m_y \sin^2\phi$$

In the isotropic case where  $m_x = m_y = m$ , we get :

$$m_n = m \cos^2\phi + m \sin^2\phi = m (\cos^2\phi + \sin^2\phi) = m$$

Whenever  $m_x$  is equal to  $m_y$  i.e. isotropic reinforcement, the resulting moment is always  $m$  whatever the orientation of the sets of reinforcement are in relation to the yield line.

## Johansen's deflection formulae

Johansen [6] saw little point in making particularly accurate deflection calculations – he felt it was more important to understand its order of magnitude. One reason he cited was the variation in concrete's modulus of elasticity. For the sake of explanation and to provide designers with an 'order of magnitude' check on other methods, his formulae for one-way and two-way and flat slabs are given here.

### One-way and two-way slabs

Johansen showed that by a suitable choice of a One-way strip taken out of any slab with a uniformly distributed load, restrained or simply supported, and analysed using the yield line theory, the deflection,  $u$ , could be estimated by the formula:

$$u = \frac{m_{serv} L^2}{8EI}$$

Where

$m_{serv}$  is the maximum serviceability span moment in the slab [kNm/m]. This can be taken as being equal to the plastic yield line moment divided by the global safety factor. The strip containing this moment must be chosen to coincide with the location where the maximum elastic moment is likely to act. In the case of rectangular slabs the strip will be orientated parallel to the shorter sides.

$E$  is the modulus of elasticity of concrete.  $E$  should include for long-term effects, such as creep and shrinkage. (kN/m<sup>2</sup>)

$I$  is the Section moment of inertia (m<sup>4</sup>). It should be noted that Johansen used gross concrete section properties ignoring reinforcement and the possibility of cracked section, i.e.  $I = bd^3/12$ . Practitioners may apply a factor to allow for cracking and cracked section properties.

### Flat slabs

Johansen suggested that the deflection,  $u$ , could be checked on a diagonal strip:

$$u = \frac{m_s L_o^2}{8EI} = \frac{m_s}{8EI} \left( \sqrt{(L_x^2 + L_y^2)} - 2c \right)^2$$

Where

$m_s$  is the larger of the serviceability moments in the two directions  $m_x$  or  $m_y$  [kNm/m]

$L_x, L_y$  is the span in the two directions x and y [m]

$E$  is the modulus of elasticity of concrete.  $E$  should include for long-term effects, such as creep and shrinkage. [kN/m<sup>2</sup>]

$I$  is the section moment of inertia [m<sup>4</sup>]. It should be noted that Johansen used gross concrete section properties ignoring reinforcement and the possibility of cracked section, i.e.  $I = bd^3/12$

$L_o$  clear span between columns diagonally across the bay  
 $2c$  dimension from edge of column 1 to its centre line plus dimension from edge of diagonally opposite column 2 to its centre line [m]

## Deflection: redistribution coefficient, $\beta_b$

When designing a slab at the ultimate limit state using Yield Line theory, it is usual to check deflection using span/depth ratios. The redistribution coefficient,  $\beta_b$ , is used when considering deflection in equation 8 of BS 8110, to determine the service stress in reinforcement in order to determine a modification factor to be applied to the basic span to depth ratio. In association with yield line designs,  $\beta_b$  is often taken as being 1.1 for the end span. This section seeks to prove that a value of 1.1 is valid for end spans.

Equation 8 of BS 8110 is as follows:

$$f_s = 2f_y A_{sreq} / (3A_{sprov} \beta_b)$$

Essentially  $2f_y/3$ , relates to going from Ultimate moments to serviceability moments,  $A_{sreq}/A_{sprov}$  relates to any additional steel the designer may choose to use, and  $1/\beta_b$  accounts for any redistribution that may have taken place (in the span).

### Ultimate moment

Considering end spans to be critical: for one-way spanning slabs the general yield line formula is:

$$m = \frac{nL^2}{2(\sqrt{1+i_1} + \sqrt{1+i_2})^2}$$

From this formula ultimate bending moment coefficients can be derived viz:

**Table A.1** Maximum end span yield line moment 'coefficient',  $k_{yab}$

Max end span yield line moment 'coefficient', $k_{yab}$			
$i_2 = 0.5$	$i_2 = 1.0$	$i_2 = 1.5$	$i_2 = 2.0$
0.101	0.086	0.075	0.067

Where

$$i_2 = m'/m = \text{first internal support moment / end span moment} \\ \text{assuming } i_1 = 0$$

Ultimate moment end span in span,  $M_{Uab} = k_{yab} \times n \times L^2$

Where

$k_{yab}$  is the coefficient for end span moment in a yield line design.

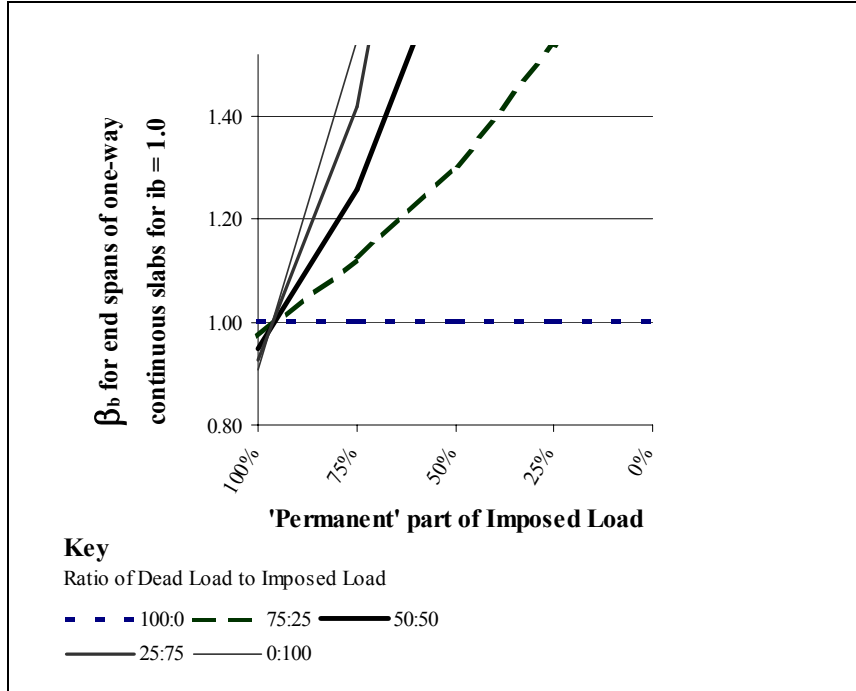
$$n = 1.4 g_k + 1.6 q_k$$

### Serviceability moment

At the serviceability limit state an elastic analysis is appropriate. For simple one-way continuous elements, the bending moment coefficients from published tables [29] may be used.

When the serviceability and associated ultimate moments are considered together, it can be shown that there are few circumstances where  $\beta_b$  should be taken as less than 1.1 for end spans (or 1.2 for internal spans). Figure A.1 shows that a figure of less than 1.1 for end spans is appropriate only when 100% of the imposed load is considered permanent and/or the ratio of dead to live load exceeds about 5.

Of course, deflection should be considered on a case-by-case basis.

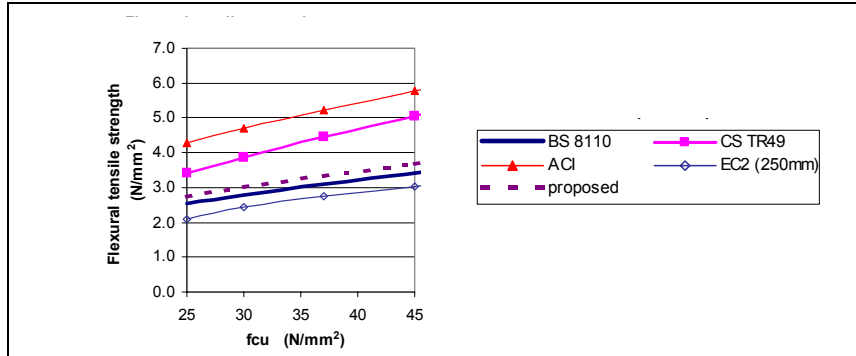


**Figure A.1**  $\beta_b$  for end spans of one-way continuous slabs for  $i_b = 1.0$

## Flexural tensile strength of concrete

When considering one of the options for curtailment of reinforcement in Example 3B (specifically part b) iii), the flexural tensile strength of concrete was used to justify the moment capacity of a section. Most design codes recognise some flexural strength of concrete and some codes and other references are illustrated in the figure below and table opposite.

Comparing flexural tensile stresses with flexural tensile strength ignores the effects of restraint inherent in any slab. While Eurocode 2 gives some guidance design to BS 8110 requires some judgement. The use of 66% of  $0.55\sqrt{f_{cu}}$  for the allowable flexural tensile strength of concrete in Example 3B would appear to be justified. In cases where there is significant restraint, designers may choose to use a lower figure.



**Figure A.2** Flexural tensile strength of concrete

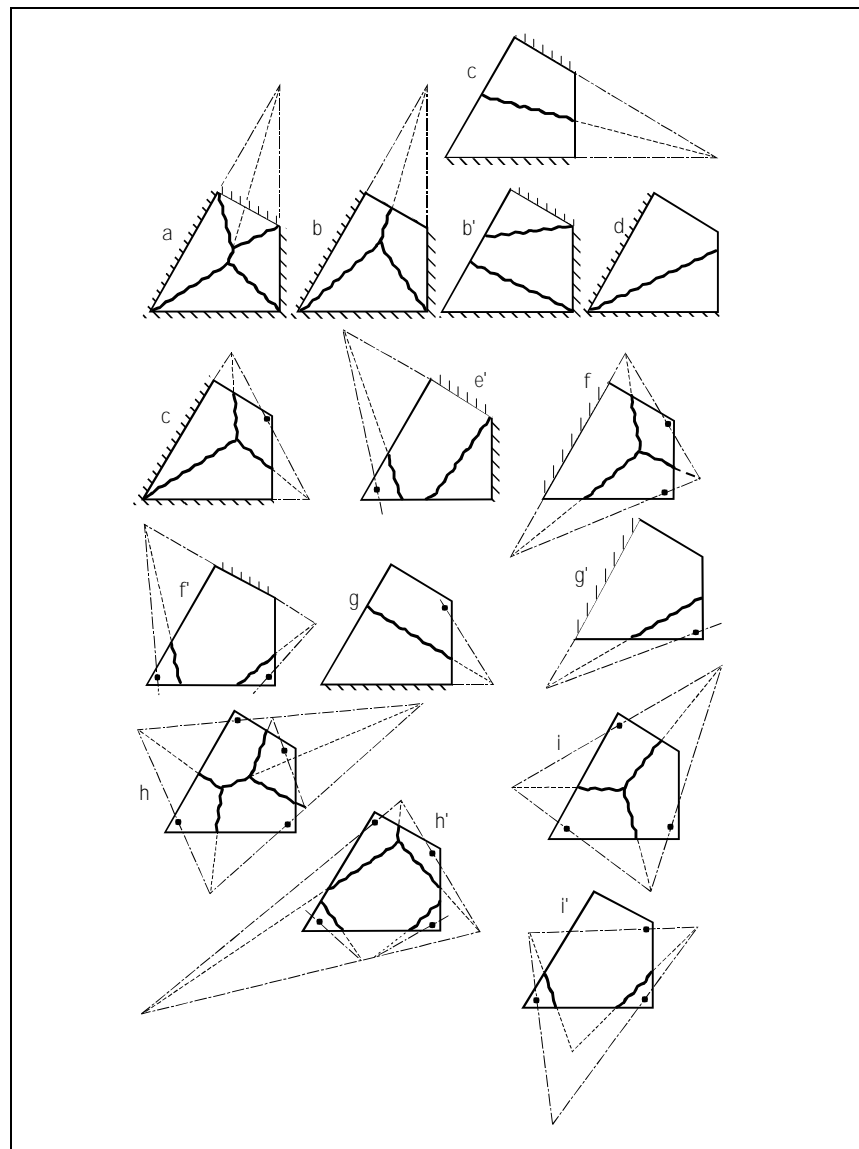


**Table A.2** Flexural tensile strength of concrete

Reference	Flexural tensile strength (modulus of rupture)	Concrete grade ( $f_{ck}/f_{cu}$ )		
		C20/25	C30/37	C40/50
BS 8110 Pt. 1 [7] Cl 4.3.4.3, allowable flexural tensile stress	$0.51 \sqrt{f_{cu}}$	2.55	3.10	3.61
CS TR 49, $f_{ft}$ [32]	$0.40 f_{cu}^{2/3}$	3.42	4.44	5.43
ACI, $f_{ft}$ [33]	$0.86 \sqrt{f_{cu}}$	4.30	5.23	6.08
Eurocode 2, $f_{ctk}^{\#}$	$\text{Max}(1.6-h/1000,1) \times 0.7 \times 0.3 f_{ck}^{2/3}$			
	h=200 mm	2.17	2.84	3.44
	h=250 mm	2.09	2.74	3.32
	h=300 mm	2.01	2.64	3.19
	h>=600 mm	1.55	2.03	2.46
Used in <i>Practical Yield Line Design</i>	$0.55 \sqrt{f_{cu}}$	2.75	3.35	3.89
<p><b>Notes</b></p> <ol style="list-style-type: none"> <li>1. A partial safety factor, <math>\gamma_m</math> ( = 1.5) should be applied as necessary to all values when assessing strength.</li> <li>2. To account for restraint, shrinkage etc a reduction factor should be applied to the values (except to <math>f_{ctk}</math>)</li> </ol> <p># As <math>u_{ls}</math> is being considered this is the characteristic value. According to Eurocode 2, Cl 7.4.3(4) it may be implied that <math>f_{ctk}</math> makes allowance for restraint.</p>				

## Failure patterns

As an *aide memoire*, the failure patterns from Johansen [6] are reproduced below.



**Figure A.3** Common failure patterns

NB. Folded plate and local failures are not shown

## List of examples

Example 2A	Two-way slab using the Work Method (simple yield pattern)	33
Example 2B	Two-way slab using the Work Method (precise yield pattern)	36
Example 2C	Two-way slab using the Work Method (orthotropic slab)	41
Example 3A	One-way slab using formulae (continuous slab)	53
Example 3B	One-way slab, curtailment of reinforcement	57
Example 3C	One-way slab using formulae (check for $m > 70\%$ elastic moment)	62
Example 3D	Two-way slab using formulae (with udl and line load)	69
Example 3E	Two-way slab using formulae (supported on 3 sides)	77
Example 3F	Two-way slab using formulae (supported on 3 sides with line load)	80
Example 3G	Two-way spanning balcony slab using formulae (supported on 2 adjacent sides)	86
Example 4A	Flat slab using formulae	99
Example 4B	Flat slab (with void) using the Work Method	109
Example 4C	Flat slab using formulae (with line load)	114
Example 4D	Irregularly supported flat slab using the Work Method	124
Example 4E	Two-way slab with beams using formulae (flexible beams)	129
Example 4F	Piled raft using the Work Method	137
Example 4G	Hole in two-way slab using the Work Method	144
Example A1	Equilibrium Method	162

Whilst the examples are to BS 8110, the principles of design are applicable to Eurocode 2, EN 1992-1-1.

## List of tables

Table 1.1	Configurations of flexural reinforcement in the in-situ building at Cardington	4
Table 1.2	Rules for yield line patterns	9
Table 1.3	Upper and lower bound ultimate load theories	13
Table 1.4	The effects of corner continuity on corner levers in a simply supported square slab	15
Table 1.5	Minimum characteristic reinforcement strain at maximum stress	17
Table 2.1	Comparison of yield line methods	37
Table 2.2	Rules for transforming orthotropic slabs to isotropic slabs for the purpose of analysis	40
Table 3.1	Formulae for one-way slabs - to establish midspan yield line moment 'm' in a span of a continuous slab	47
Table 3.2	Location of maximum midspan moments and points of contraflexure	48
Table 3.3	End span curtailment formulae: end span lightly loaded	49
Table 3.4	Internal span curtailment formulae: internal span lightly loaded	50
Table 3.5	Elastic moment coefficients for one-way spanning slabs - of approximately equal spans prior to any moment redistribution, all spans loaded	51
Table 3.6a	Formulae for slabs supported on four sides	67
Table 3.6b	Formulae for slabs supported on four sides (continued)	68
Table 3.7	Formulae for rectangular slabs supported on three sides with $h_1 + h_3 < b$	74
Table 3.8	Formulae for rectangular slabs supported on three sides with $h_2 < a$	75
Table 3.9	Formulae for rectangular slabs supported on two adjacent sides	85
Table 3.10	Flat slabs: formulae for local failure pattern at internal column support (in slabs with isotropic reinforcement)	90
Table 3.11	Flat slabs: formulae for local failure pattern at perimeter columns (in slabs with isotropic reinforcement)	91
Table 4.1	Common concentrations of top reinforcement over columns when using Yield Line Design	94
Table A.1	Maximum end span yield line moment 'coefficient', $k_{yab}$	165
Table A.2	Flexural tensile strength of concrete	167

## List of figures

Figure 1.1	European Concrete Building Project at Cardington - 4 <sup>th</sup> floor during construction .....	5
Figure 1.2	An irregular flat slab .... ..	6
Figure 1.3	... may be analysed using Yield Line Design - by considering quadrilaterals .....	6
Figure 1.4	A piled raft – easily dealt with using Yield Line Theory and Design .....	7
Figure 1.5	Onset of yielding of bottom reinforcement at point of maximum deflection in a simply supported two-way slab .....	8
Figure 1.6	The formation of a mechanism in a simply supported two-way slab with the bottom steel having yielded along the yield lines .....	9
Figure 1.7	Simple yield line patterns .....	10
Figure 1.8	Fan collapse pattern for a heavy concentrated load onto a reinforced slab .....	11
Figure 1.9	Deformed shape at failure .....	12
Figure 1.10	The effect of corner levers on a simply supported square slab where corners are held down and prevented from lifting .....	14
Figure 1.11	Typical stress-stain diagrams of reinforcing steel [3] .....	17
Figure 2.1	A simply supported one-way slab .....	24
Figure 2.2	Simply supported slab yield line pattern .....	25
Figure 2.3	Valid patterns for a two-way slab .....	26
Figure 2.4	Invalid pattern for the two-way slab above .....	27
Figure 2.5	Valid patterns for a slab supported on two adjacent edges and a column .....	27
Figure 2.6	An invalid pattern .....	27
Figure 2.7	Lengths $L_1$ and $L_2$ .....	28
Figure 2.8	Dealing with angled yield lines .....	29
Figure 2.9	Principles of expenditure of external loads: E .....	30
Figure 2.10	Principles of dissipation of internal energy, D .....	32
Figure 2.11	Slab with orthotropic reinforcement .....	38
Figure 3.1	One-way spanning slab .....	45
Figure 3.2	Axonometric view of a simply supported one-way spanning slab .....	45
Figure 3.3	Loading, hinge locations and bending moment diagram for simply supported slab .....	46
Figure 3.4	Principles of designing slabs supported on four sides .....	64
Figure 3.5	Slab supported on four sides .....	66
Figure 3.6	Rectangular slab supported on three sides, Case A where $h_1 + h_3 < b$ .....	74
Figure 3.7	Rectangular slab supported on three sides, Case B where $h_2 < a$ (or $h_1 + h_3 = b$ ) .....	75
Figure 3.8	Slab supported on two adjacent sides .....	84
Figure 3.9	Flat slabs: folded plate collapse mode .....	88
Figure 3.10	Flat slabs: combined folded plate collapse mode .....	89
Figure 3.11	Flat slabs: conical collapse modes (with isotropic reinforcement) .....	89
Figure 4.1	Reinforcement layout for flat slab example 4A .....	108
Figure 4.2	Reinforcement layout with recess .....	113
Figure 4.3	Reinforcement layout with recess and edge load .....	119
Figure 4.4	Part general arrangement drawing of a block of flats .....	122
Figure 4.5a	Part general arrangement drawing of a block of flats showing a 'folding plate' mechanism that needs to be investigated .....	122
Figure 4.5b	Part general arrangement drawing of a block of flats showing some of the possible polygonal failure patterns that need to be investigated .....	123
Figure 4.6.	Extract from the actual reinforcement drawing for the slab used in Example 4D .....	126
Figure 4.7	Possible modes of failure for a slab supported by beams and walls .....	127
Figure 4.8	Section through slab and beams showing length of positive yield line in slab and beam flange width in a mode 2 failure .....	128

---

Figure 4.9	General arrangement of basement and raft foundation showing possible yield line failure patterns .....	137
Figure 4.10	Detailed arrangement of raft with respect to failure pattern 2a .....	138
Figure 4.11	General arrangement of existing slab with proposed hole .....	144
Figure 4.12	Possible failure pattern ignoring hole .....	145
Figure 4.13	Possible failure pattern with hole .....	146
Figure 5.1	One Warrington Gardens, London W9 .....	148
Figure 5.2	43 - 47 St John's Wood Road, London NW8 .....	149
Figure 5.3	Onslow House, Saffron Hill, London EC1 .....	150
Figure 5.4	Nokia Headquarters, Stanhope Road, Camberley .....	151
Figure 5.5	East India Dock Redevelopment, London Docklands .....	152
Figure 5.6	66 Buckingham Gate, London SW1 .....	153
Figure 5.7	80 Oxford Road, High Wycombe .....	154
Figure A.1	$\beta_b$ for end spans of one-way continuous slabs for $i_b = 1.0$ .....	166
Figure A.2	Flexural tensile strength of concrete .....	166
Figure A.3	Common failure patterns .....	168



CI/Sfb			
UDC	624.046.5		

## Practical Yield Line Design: Applied Yield Line Theory

**This publication is an outcome of the European Concrete Building Project at Cardington, where Yield Line Design of concrete flat slabs was found to be 'easily the best opportunity identifiable to the concrete frame industry'.**

This publication aims to promote better knowledge and understanding of reinforced concrete design and building technology. It is intended for use by those experienced engineers wishing to extend their portfolio of methods of analysis and design for more efficient and effective designs.

**Gerard Kennedy** is the main author of this publication. He is a consultant to Powell Tolner and Associates, Consulting Civil and Structural Engineers, where over a 27 year career of general engineering practice, he became the partner in charge of design. Gerard has a particular interest in Yield Line Analysis and its practical application to reinforced concrete structures.

**Charles Goodchild** is Principal Structural Engineer of The **Concrete** Centre, where he specialises in promoting efficiency in concrete design and construction in multi-storey structures. In addition to writing some of the text, he was responsible for the management of this project and publication.

TCC/03/3

Published September 2004

ISBN 1-904818-08-0

Price Group L.

© The **Concrete** Centre

Riverside House, 4 Meadows Business Park,  
Station Approach, Blackwater, Camberley, Surrey GU17 9AB

**Tel:** +44 (0)1276 606800 **Fax:** +44 (0)1276 606801

[www.concretecentre.com](http://www.concretecentre.com)