

Discovering
Geometry
An Investigative Approach

**Practice Your Skills
with Answers**

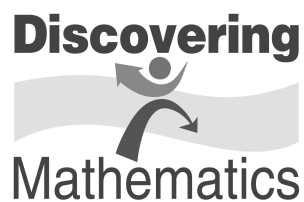

Kendall Hunt
publishing company

Teacher's Materials Project Editor: Elizabeth DeCarli

Project Administrator: Brady Golden

Coordinating Writer: Jennifer North Morris

Contributors: David Rasmussen, Ralph Bothe, Judy Hicks, Michael Serra

Accuracy Checker: Dudley Brooks

Production Editor: Holly Rudelitsch

Copyeditor: Jill Pellarin

Editorial Production Manager: Christine Osborne

Production Supervisor: Ann Rothenbuhler

Production Coordinator: Jennifer Young

Text Designers: Jenny Somerville, Garry Harman

Composition, Technical Art, Prepress: ICC Macmillan Inc.

Cover Designer: Jill Kongabel

Printer: Data Reproductions

Textbook Product Manager: James Ryan

Executive Editor: Casey FitzSimons

Publisher: Steven Rasmussen

©2008 by Kendall Hunt Publishing. All rights reserved.

Cover Photo Credits: Background image: Doug Wilson/Westlight/Corbis.
Construction site image: Sonda Dawes/The Image Works. All other images:
Ken Karp Photography.

Limited Reproduction Permission

The publisher grants the teacher whose school has adopted *Discovering Geometry*, and who has received *Discovering Geometry: An Investigative Approach, Practice Your Skills with Answers* as part of the Teaching Resources package for the book, the right to reproduce material for use in his or her own classroom. Unauthorized copying of *Discovering Geometry: An Investigative Approach, Practice Your Skills with Answers* constitutes copyright infringement and is a violation of federal law.

All registered trademarks and trademarks in this book are the property of their respective holders.

Kendall Hunt Publishing
4050 Westmark Drive
PO Box 1840
Dubuque, IA 52004-1840
www.kendallhunt.com

Printed in the United States of America

10 9 8 7 6 5 4 3 2

13 12 11 10 09 08

ISBN 978-1-55953-894-7

Contents

Introduction	vi
Chapter 1	
Lesson 1.1: Building Blocks of Geometry	1
Lesson 1.2: Poolroom Math	2
Lesson 1.3: What's a Widget?	3
Lesson 1.4: Polygons	4
Lesson 1.5: Triangles	5
Lesson 1.6: Special Quadrilaterals	6
Lesson 1.7: Circles	7
Lesson 1.8: Space Geometry	8
Lesson 1.9: A Picture Is Worth a Thousand Words	9
Chapter 2	
Lesson 2.1: Inductive Reasoning	10
Lesson 2.2: Finding the n th Term	11
Lesson 2.3: Mathematical Modeling	12
Lesson 2.4: Deductive Reasoning	13
Lesson 2.5: Angle Relationships	14
Lesson 2.6: Special Angles on Parallel Lines	15
Chapter 3	
Lesson 3.1: Duplicating Segments and Angles	16
Lesson 3.2: Constructing Perpendicular Bisectors	17
Lesson 3.3: Constructing Perpendiculars to a Line	18
Lesson 3.4: Constructing Angle Bisectors	19
Lesson 3.5: Constructing Parallel Lines	20
Lesson 3.6: Construction Problems	21
Lesson 3.7: Constructing Points of Concurrency	22
Lesson 3.8: The Centroid	23
Chapter 4	
Lesson 4.1: Triangle Sum Conjecture	24
Lesson 4.2: Properties of Isosceles Triangles	25
Lesson 4.3: Triangle Inequalities	26
Lesson 4.4: Are There Congruence Shortcuts?	27
Lesson 4.5: Are There Other Congruence Shortcuts?	28
Lesson 4.6: Corresponding Parts of Congruent Triangles	29
Lesson 4.7: Flowchart Thinking	30
Lesson 4.8: Proving Special Triangle Conjectures	31

Chapter 5

Lesson 5.1: Polygon Sum Conjecture	32
Lesson 5.2: Exterior Angles of a Polygon	33
Lesson 5.3: Kite and Trapezoid Properties	34
Lesson 5.4: Properties of Midsegments	35
Lesson 5.5: Properties of Parallelograms	36
Lesson 5.6: Properties of Special Parallelograms	37
Lesson 5.7: Proving Quadrilateral Properties	38

Chapter 6

Lesson 6.1: Tangent Properties	39
Lesson 6.2: Chord Properties	40
Lesson 6.3: Arcs and Angles	41
Lesson 6.4: Proving Circle Conjectures	42
Lesson 6.5: The Circumference/Diameter Ratio	43
Lesson 6.6: Around the World	44
Lesson 6.7: Arc Length	45
Exploration: Intersecting Secants, Tangents, and Chords	46

Chapter 7

Lesson 7.1: Transformations and Symmetry	47
Lesson 7.2: Properties of Isometries	48
Lesson 7.3: Compositions of Transformations	49
Lesson 7.4: Tessellations with Regular Polygons	50
Lessons 7.5–7.8: Tessellations	51

Chapter 8

Lesson 8.1: Areas of Rectangles and Parallelograms	52
Lesson 8.2: Areas of Triangles, Trapezoids, and Kites	53
Lesson 8.3: Area Problems	54
Lesson 8.4: Areas of Regular Polygons	55
Lesson 8.5: Areas of Circles	56
Lesson 8.6: Any Way You Slice It	57
Lesson 8.7: Surface Area	58

Chapter 9

Lesson 9.1: The Theorem of Pythagoras	59
Lesson 9.2: The Converse of the Pythagorean Theorem	60
Lesson 9.3: Two Special Right Triangles	61
Lesson 9.4: Story Problems	62
Lesson 9.5: Distance in Coordinate Geometry	63
Lesson 9.6: Circles and the Pythagorean Theorem	64

Chapter 10

Lesson 10.1: The Geometry of Solids	65
Lesson 10.2: Volume of Prisms and Cylinders	66
Lesson 10.3: Volume of Pyramids and Cones	67
Lesson 10.4: Volume Problems	68
Lesson 10.5: Displacement and Density	69
Lesson 10.6: Volume of a Sphere	70
Lesson 10.7: Surface Area of a Sphere	71

Chapter 11

Lesson 11.1: Similar Polygons	72
Lesson 11.2: Similar Triangles	73
Lesson 11.3: Indirect Measurement with Similar Triangles	74
Lesson 11.4: Corresponding Parts of Similar Triangles	75
Lesson 11.5: Proportions with Area	76
Lesson 11.6: Proportions with Volume	77
Lesson 11.7: Proportional Segments Between Parallel Lines	78

Chapter 12

Lesson 12.1: Trigonometric Ratios	79
Lesson 12.2: Problem Solving with Right Triangles	80
Lesson 12.3: The Law of Sines	81
Lesson 12.4: The Law of Cosines	82
Lesson 12.5: Problem Solving with Trigonometry	83

Chapter 13

Lesson 13.1: The Premises of Geometry	84
Lesson 13.2: Planning a Geometry Proof	85
Lesson 13.3: Triangle Proofs	86
Lesson 13.4: Quadrilateral Proofs	87
Lesson 13.5: Indirect Proof	88
Lesson 13.6: Circle Proofs	89
Lesson 13.7: Similarity Proofs	90

Answers	91
---------------	----

Introduction

The author and editors of *Discovering Geometry: An Investigative Approach* are aware of the importance of students developing geometry skills along with acquiring concepts through investigation. The student book includes many skill-based exercises. These *Practice Your Skills* worksheets provide problems similar to the introductory exercises in each lesson of *Discovering Geometry*. Like those exercises, these worksheets allow students to practice and reinforce the important procedures and skills developed in the lessons. Some of these problems provide non contextual skills practice. Others give students an opportunity to apply geometry concepts in fairly simple, straightforward contexts. Some are more complex problems that are broken down into small steps.

You might assign the *Practice Your Skills* worksheet for every lesson, or only for those lessons your students find particularly difficult. Or, you may wish to assign the worksheets on an individual basis, only to those students who need extra help. One worksheet has been provided for nearly every lesson. There are no worksheets for Chapter 0, and the optional tessellation lessons have been combined into two worksheets. To save you the time and expense of copying pages, you can give students the inexpensive *Practice Your Skills Student Workbook*, which does not have answers. Though the copyright allows you to copy pages from *Practice Your Skills with Answers* for use with your students, the consumable *Practice Your Skills Student Workbook* should not be copied. Students, parents, and mentors can also download the student worksheets from flourishkh.com.

Lesson 1.1 • Building Blocks of Geometry

Name _____ Period _____ Date _____

For Exercises 1–7, complete each statement. $\overline{PS} = 3$ cm.

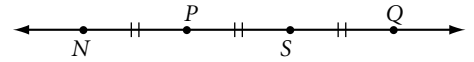

- The midpoint of \overline{PQ} is _____.
- $NQ =$ _____.
- Another name for \overline{NS} is _____.
- S is the _____ of \overrightarrow{SQ} .
- P is the midpoint of _____.
- $\overline{NS} \cong$ _____.
- Another name for \overline{SN} is _____.
- Name all pairs of congruent segments in $KLMN$. Use the congruence symbol to write your answer.
- $M(-4, 8)$ is the midpoint of \overline{DE} . D has coordinates $(6, 1)$. Find the coordinates of E .

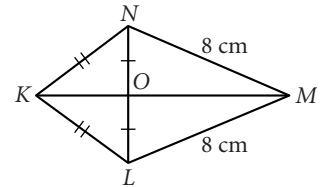

For Exercises 10 and 11, use a ruler to draw each figure. Label the figure and mark the congruent parts.

- \overline{AB} and \overline{CD} with M as the midpoint of both \overline{AB} and \overline{CD} . $AB = 6.4$ cm and $CD = 4.0$ cm. A , B , and C are not collinear.
- \overline{AB} and \overline{CD} . C is the midpoint of \overline{AB} , with $AC = 1.5$ cm. D , not on \overline{AB} , is the midpoint of \overline{AE} , with $AD = 2BC$.
- Sketch six points A , B , C , D , E , and F , no three of which are collinear. Name the lines defined by these points. How many lines are there?
- In the figure below, $\{B, C, H, E\}$ is a set of four coplanar points. Name two other sets of four coplanar points. How many sets of four coplanar points are there?

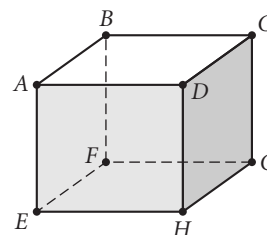

Cube

Lesson 1.2 • Poolroom Math

Name _____ Period _____ Date _____

For Exercises 1–5, use the figure at right to complete each statement.

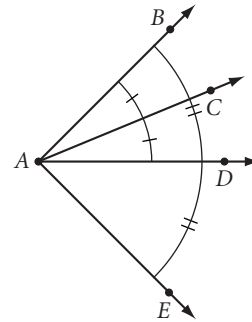

1. A is the _____ of $\angle BAE$.
2. \overrightarrow{AD} is the _____ of $\angle BAE$.
3. \overrightarrow{AD} is a _____ of $\angle DAE$.
4. If $m\angle BAC = 42^\circ$, then $m\angle CAE =$ _____.
5. $\angle DAB \cong$ _____.

For Exercises 6–9, use your protractor to find the measure of each angle to the nearest degree.

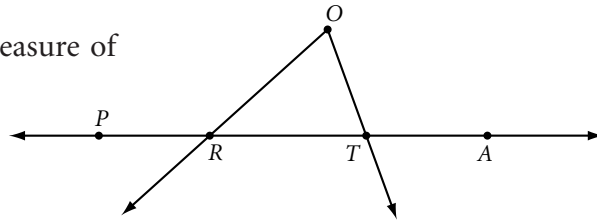

6. $m\angle PRO$
7. $m\angle ORT$
8. $m\angle O$
9. $m\angle RTO$

For Exercises 10–12, use your protractor to draw and then label each angle with the given measure.

10. $m\angle MNO = 15^\circ$
11. $m\angle RIG = 90^\circ$
12. $m\angle z = 160^\circ$

For Exercises 13–15, find the measure of the angle formed by the hands at each time.

13. 3:00
14. 4:00
15. 3:30

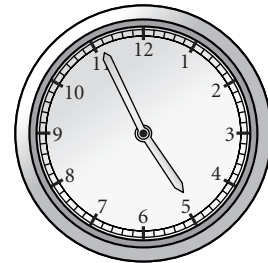

For Exercises 16 and 17, mark each figure with all the given information.

16. $m\angle ADB = 90^\circ$, $AD = BD$, $\angle DAB \cong \angle DBA$

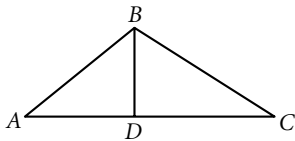

17. $m\angle RPQ = 90^\circ$, $QR = TZ$, $RT = QZ$, $\angle Q \cong \angle T$

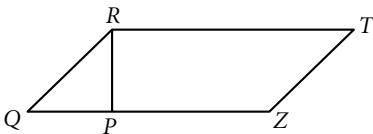

Lesson 1.3 • What's a Widget?

Name _____ Period _____ Date _____

For Exercises 1–9, match each term with one of the items (a to i) below.

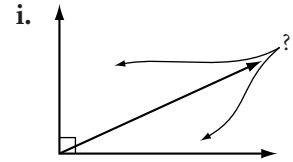
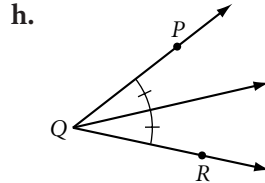
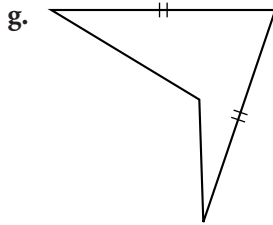
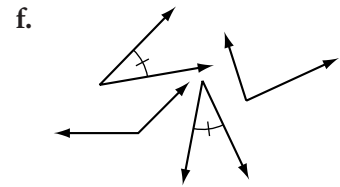
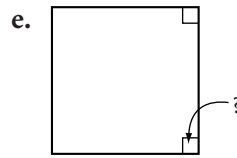
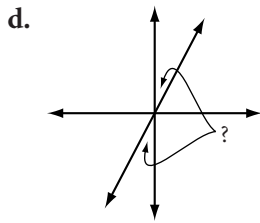
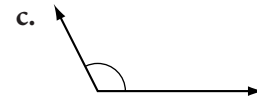
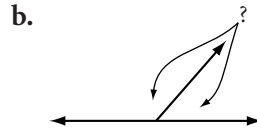
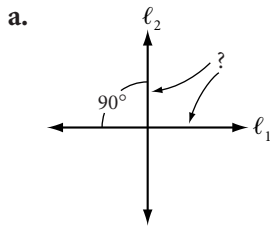

- | | |
|-----------------------------|--------------------------------|
| 1. _____ Vertical angles | 2. _____ Obtuse angle |
| 3. _____ Right angle | 4. _____ Complementary angles |
| 5. _____ Congruent angles | 6. _____ Linear pair of angles |
| 7. _____ Bisected angle | 8. _____ Perpendicular lines |
| 9. _____ Congruent segments | |
10. If $m\angle P = 13^\circ$, $m\angle Q = 77^\circ$, and $\angle Q$ and $\angle R$ are complementary, what can you conclude about $\angle P$ and $\angle R$? Explain your reasoning.

For Exercises 11–13, sketch, label, and mark a figure showing each property.

11. $\ell_1 \parallel \ell_2, \ell_2 \perp \ell_3$

12. $\overline{PQ} \perp \overline{PR}$

13. $\angle BAC \cong \angle XAY, CX = BC$

Lesson 1.4 • Polygons

Name _____ Period _____ Date _____

For Exercises 1–8, complete the table.

Polygon name	Number of sides	Number of diagonals
1. Triangle		
2.		2
3.	5	
4. Hexagon		
5. Heptagon		
6.	8	
7.		35
8.	12	

For Exercises 9 and 10, sketch and label each figure. Mark the congruences.

9. Concave pentagon *PENTA*, with external diagonal \overline{ET} , and $\overline{TA} \cong \overline{PE}$.

10. Equilateral quadrilateral *QUAD*, with $\angle Q \cong \angle U$.

For Exercises 11–14, sketch and use hexagon *ABCDEF*.

- Name the diagonals from *A*.
- Name a pair of consecutive sides.
- Name a pair of consecutive angles.
- Name a pair of non-intersecting diagonals.

For Exercises 15–18, use the figures at right.

$MNOPQ \cong RSTUV$

15. $m\angle N =$ _____

16. $VR =$ _____

17. $m\angle P =$ _____

18. $ON =$ _____

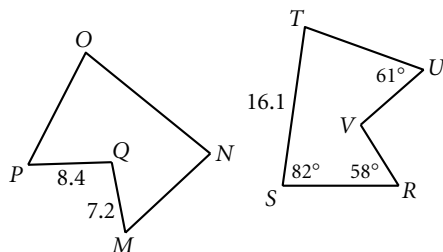

19. The perimeter of a regular pentagon is 31 cm. Find the length of each side.

Lesson 1.5 • Triangles

Name _____ Period _____ Date _____

For Exercises 1–5, use the figure at right. Name a pair of

1. Parallel segments
2. Perpendicular segments
3. Congruent segments
4. Supplementary angles
5. Linear angles

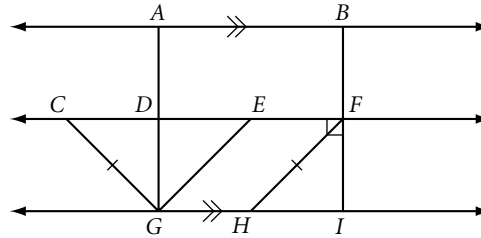

For Exercises 6 and 7, sketch, label, and mark each figure.

6. Isosceles obtuse triangle TRI with vertex angle T .

7. Scalene right triangle SCA with midpoints L , M , and N on \overline{SC} , \overline{CA} , and \overline{SA} , respectively.

For Exercises 8 and 9, use your geometry tools to draw each figure.

8. Acute isosceles triangle ACD with vertex angle A measuring 40° .
9. Scalene right triangle RGH .

For Exercises 10–12, use the graph at right.

10. Locate F so that $\triangle ABF$ is a right triangle.
11. Locate D so that $\triangle ABD$ is an isosceles triangle.
12. Locate G so that $\triangle ABG$ is scalene and not a right triangle.

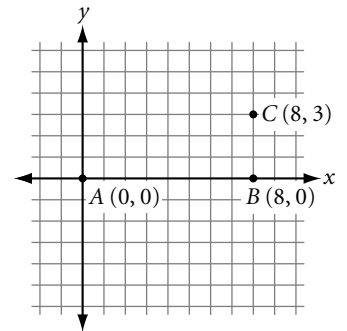

Lesson 1.6 • Special Quadrilaterals

Name _____ Period _____ Date _____

For Exercises 1–6, sketch, label, and mark each figure.

1. Parallelogram $PGRA$
2. Square $SQRE$
3. Rhombus $RHOM$ with acute $\angle H$.
4. Trapezoid $TRAP$ with $\overline{TR} \parallel \overline{AP}$, $\overline{RE} \perp \overline{PA}$, and $P, E,$ and A collinear.
5. Kite $KITE$ with $EK = KI$ and obtuse $\angle K$.
6. Rectangle $RANG$ with perimeter $2a + 4b$

For Exercises 7–10, name each polygon in the figure. Assume that the grid is square.

7. Square
8. Parallelogram
9. Rhombus
10. Kite

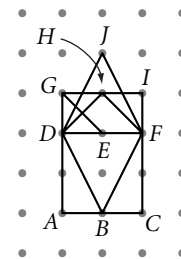

For Exercises 11–13, use the graph at right.

11. Locate D so that $ABCD$ is a rectangle.
12. Locate E so that $ABCE$ is a trapezoid.
13. Locate G so that points $A, B, C,$ and G determine a parallelogram that is not a rectangle.

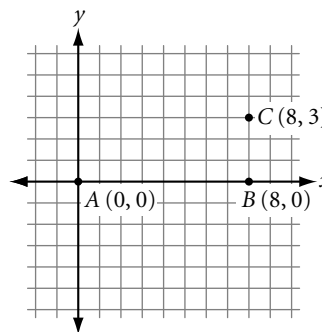

Lesson 1.7 • Circles

Name _____ Period _____ Date _____

For Exercises 1–4, use the figure at right.

1. $m\widehat{QR} = \underline{\hspace{2cm}}$ 2. $m\widehat{PR} = \underline{\hspace{2cm}}$
 3. $m\widehat{PQR} = \underline{\hspace{2cm}}$ 4. $m\widehat{QPR} = \underline{\hspace{2cm}}$

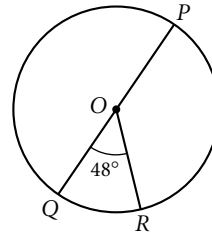

5. Sketch a circle with an inscribed pentagon.
6. Sketch a circle with a circumscribed quadrilateral.
7. A circle with center $(3, 2)$ goes through $(-2, 2)$. Give the coordinates of three other points on the circle.
8. Use a compass, protractor, and straightedge to draw circle O with diameter \overline{AB} ; radius \overline{OC} with $\overline{OC} \perp \overline{AB}$; \overline{OD} , the angle bisector of $\angle AOC$, with D on the circle; chords \overline{AC} and \overline{BC} ; and a tangent at D .

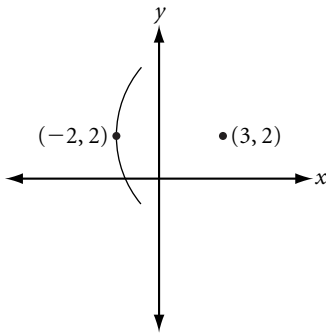

9. Use a compass to construct a circle. Label the center P . Sketch two parallel tangents. Connect the points of tangency. What do you notice about the chord?
10. Use your compass and protractor to make an arc with measure 50° , an arc with measure 180° , and an arc with measure 290° . Label each arc with its measure.
11. Use your compass to construct two circles with different radii that intersect in two points. Label the centers P and Q and the points of intersection A and B . Construct quadrilateral $PAQB$. What type of quadrilateral is it?

Lesson 1.8 • Space Geometry

Name _____ Period _____ Date _____

For Exercises 1 and 2, draw each figure.

1. A prism with a rectangular base.
2. A cylinder with base diameter greater than height.

For Exercises 3 and 4, sketch the three-dimensional figure formed by folding each net into a solid. Name the solid.

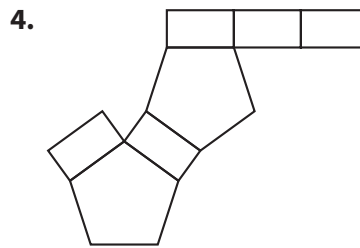
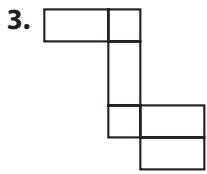

For Exercises 5 and 6, sketch the section formed when each solid is sliced by the plane as shown.

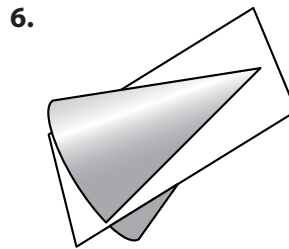
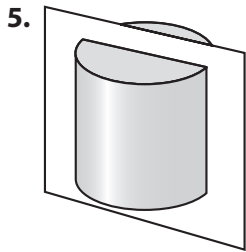

7. The prism below is built with 1-cm cubes. How many cubes are completely hidden from sight, as seen from this angle?

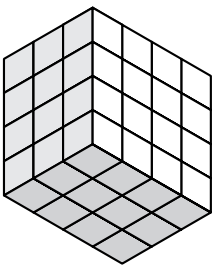

8. Find the lengths of x and y .

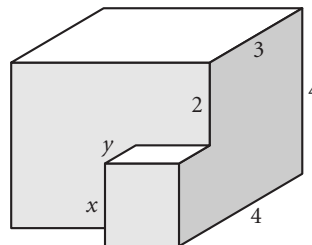

Lesson 1.9 • A Picture Is Worth a Thousand Words

Name _____ Period _____ Date _____

Read and reread each problem carefully, determining what information you are given and what it is that you trying to find.

1. A pair of parallel interstate gas and power lines run 10 meters apart and are equally distant from relay station *A*. The power company needs to locate a gas-monitoring point on one of the lines exactly 12 meters from relay station *A*. Draw a diagram showing the locus of possible locations.
2. The six members of the Senica High School math club are having a group photo taken for the yearbook. The photographer has asked the club to submit the height of each member so that he can quickly arrange them in order. The math club sent him the following information. Anica is 4 inches taller than Bruce. Charles is the same height as Ellen but an inch taller than Anica. Fred is midway between Bruce and Dora. Dora is 2 inches taller than Anica. Help out the photographer by arranging the club members in order from tallest to shortest.
3. Create a Venn diagram showing the relationships among triangles, acute triangles, isosceles triangles, and scalene triangles.

4. Sketch a possible net for each solid.

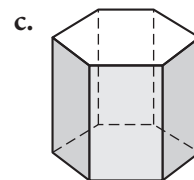
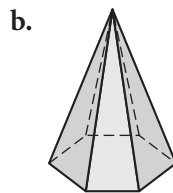
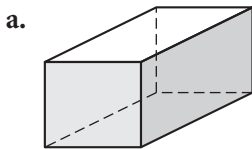

Lesson 2.1 • Inductive Reasoning

Name _____ Period _____ Date _____

For Exercises 1–7, use inductive reasoning to find the next two terms in each sequence.

1. 4, 8, 12, 16, _____, _____
2. 400, 200, 100, 50, 25, _____, _____
3. $\frac{1}{8}, \frac{2}{7}, \frac{1}{2}, \frac{4}{5},$ _____, _____
4. -5, 3, -2, 1, -1, 0, _____, _____
5. 360, 180, 120, 90, _____, _____
6. 1, 3, 9, 27, 81, _____, _____
7. 1, 5, 14, 30, 55, _____, _____

For Exercises 8–10, use inductive reasoning to draw the next two shapes in each picture pattern.

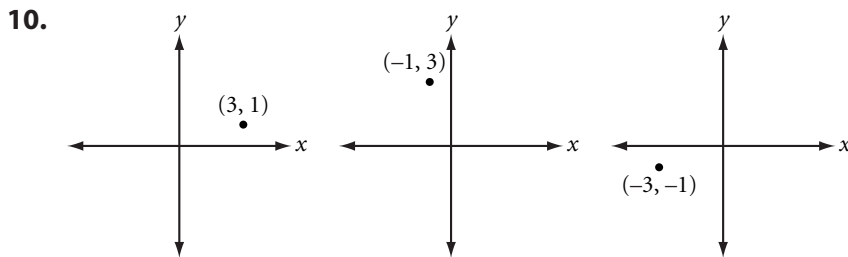
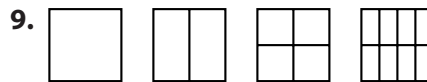
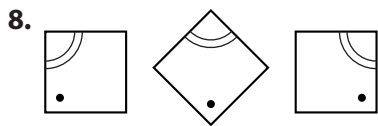

For Exercises 11–13, use inductive reasoning to test each conjecture. Decide if the conjecture seems true or false. If it seems false, give a counterexample.

11. The square of a number is larger than the number.
12. Every multiple of 11 is a “palindrome,” that is, a number that reads the same forward and backward.
13. The difference of two consecutive square numbers is an odd number.

Lesson 2.2 • Finding the n th Term

Name _____ Period _____ Date _____

For Exercises 1–4, tell whether the rule is a linear function.

1.

n	1	2	3	4	5
$f(n)$	8	15	22	29	36

2.

n	1	2	3	4	5
$g(n)$	14	11	8	5	2

3.

n	1	2	3	4	5
$h(n)$	-9	-6	-2	3	9

4.

n	1	2	3	4	5
$j(n)$	$-\frac{3}{2}$	-1	$-\frac{1}{2}$	0	$\frac{1}{2}$

For Exercises 5 and 6, complete each table.

5.

n		1	2	3	4	5
$f(n) = 7n - 12$						

6.

n		1	2	3	4	5
$g(n) = -8n - 2$						

For Exercises 7–9, find the function rule for each sequence. Then find the 50th term in the sequence.

7.

n	1	2	3	4	5	6	...	n	...	50
$f(n)$	9	13	17	21	25	29	

8.

n	1	2	3	4	5	6	...	n	...	50
$g(n)$	6	1	-4	-9	-14	-19	

9.

n	1	2	3	4	5	6	...	n	...	50
$h(n)$	6.5	7	7.5	8	8.5	9	

10. Use the figures to complete the table.

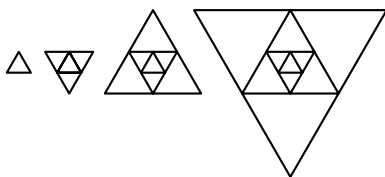

n	1	2	3	4	5	...	n	...	50
Number of triangles	1	5	9			

11. Use the figures above to complete the table. Assume that the area of the first figure is 1 square unit.

n	1	2	3	4	5	...	n	...	50
Area of figure	1	4	16			

Lesson 2.3 • Mathematical Modeling

Name _____ Period _____ Date _____

1. Draw the next figure in this pattern.

- How many small squares will there be in the 10th figure?
- How many in the 25th figure?
- What is the general function rule for this pattern?

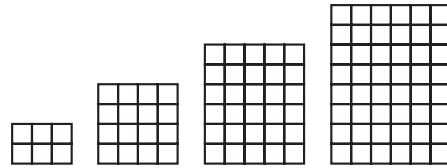

2. If you toss a coin, you will get a head or a tail. Copy and complete the geometric model to show all possible results of three consecutive tosses.

- How many sequences of results are possible?
- How many sequences have exactly one tail?
- Assuming a head or a tail is equally likely, what is the probability of getting exactly one tail in three tosses?

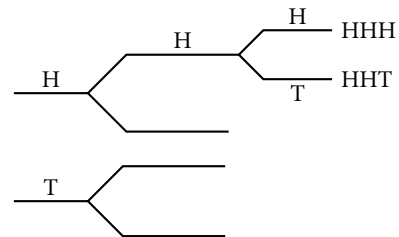

3. If there are 12 people sitting at a round table, how many different pairs of people can have conversations during dinner, assuming they can all talk to each other? What geometric figure can you use to model this situation?

4. Tournament games and results are often displayed using a geometric model. Two examples are shown below. Sketch a geometric model for a tournament involving 5 teams and a tournament involving 6 teams. Each team must have the same chance to win. Try to have as few games as possible in each tournament. Show the total number of games in each tournament. Name the teams a, b, c . . . and number the games 1, 2, 3

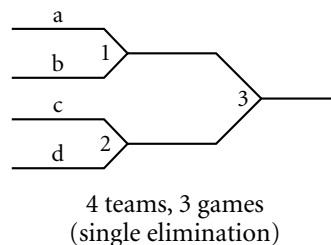
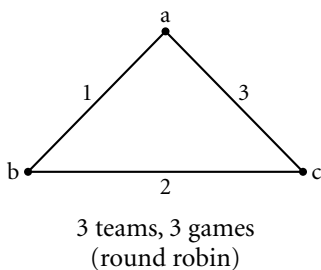

Lesson 2.4 • Deductive Reasoning

Name _____ Period _____ Date _____

1. $\triangle ABC$ is equilateral. Is $\triangle ABD$ equilateral? Explain your answer. What type of reasoning, inductive or deductive, do you use when solving this problem?

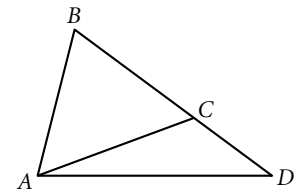

2. $\angle A$ and $\angle D$ are complementary. $\angle A$ and $\angle E$ are supplementary. What can you conclude about $\angle D$ and $\angle E$? Explain your answer. What type of reasoning, inductive or deductive, do you use when solving this problem?

3. Which figures in the last group are whatnots? What type of reasoning, inductive or deductive, do you use when solving this problem?

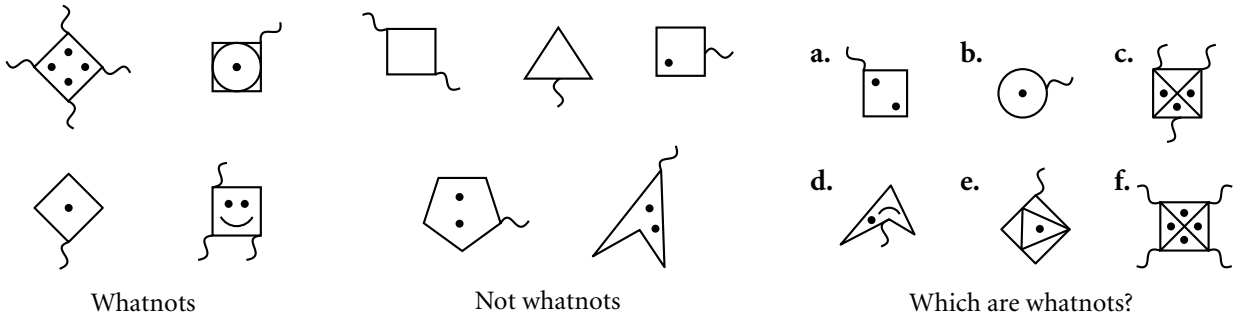

4. Solve each equation for x . Give a reason for each step in the process. What type of reasoning, inductive or deductive, do you use when solving these problems?

a. $4x + 3(2 - x) = 8 - 2x$

b. $\frac{19 - 2(3x - 1)}{5} = x + 2$

5. A sequence begins $-4, 1, 6, 11 \dots$

- a. Give the next two terms in the sequence. What type of reasoning, inductive or deductive, do you use when solving this problem?
- b. Find a rule that generates the sequence. Then give the 50th term in the sequence. What type of reasoning, inductive or deductive, do you use when solving this problem?

Lesson 2.5 • Angle Relationships

Name _____ Period _____ Date _____

For Exercises 1–6, find each lettered angle measure without using a protractor.

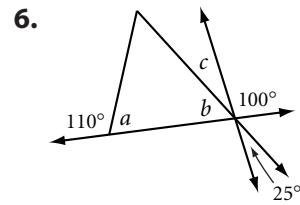
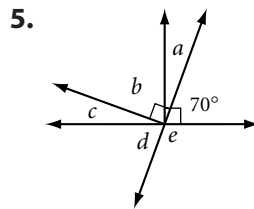
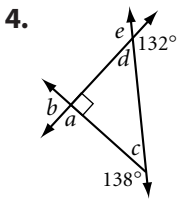
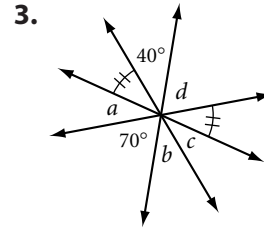
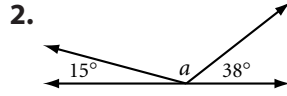
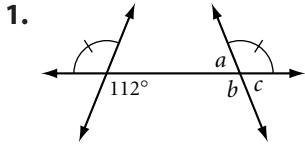

For Exercises 7–10, tell whether each statement is always (A), sometimes (S), or never (N) true.

7. _____ The sum of the measures of two acute angles equals the measure of an obtuse angle.
8. _____ If $\angle XAY$ and $\angle PAQ$ are vertical angles, then either $X, A,$ and P or $X, A,$ and Q are collinear.
9. _____ If two angles form a linear pair, then they are complementary.
10. _____ If a statement is true, then its converse is true.

For Exercises 11–15, fill in each blank to make a true statement.

11. If one angle of a linear pair is obtuse, then the other is _____.
12. If $\angle A \cong \angle B$ and the supplement of $\angle B$ has measure 22° , then $m\angle A =$ _____.
13. If $\angle P$ is a right angle and $\angle P$ and $\angle Q$ form a linear pair, then $m\angle Q$ is _____.
14. If $\angle S$ and $\angle T$ are complementary and $\angle T$ and $\angle U$ are supplementary, then $\angle U$ is a(n) _____ angle.
15. Switching the “if” and “then” parts of a statement changes the statement to its _____.

Lesson 2.6 • Special Angles on Parallel Lines

Name _____ Period _____ Date _____

For Exercises 1–3, use your conjectures to find each angle measure.

1.

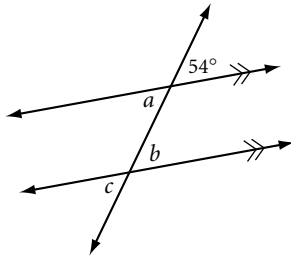

2.

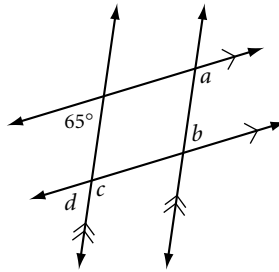

3.

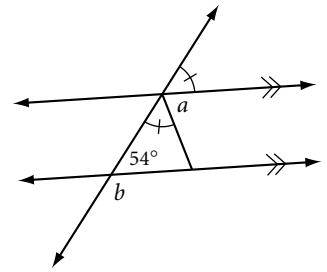

For Exercises 4–6, use your conjectures to determine whether $\ell_1 \parallel \ell_2$, and explain why. If not enough information is given, write “cannot be determined.”

4.

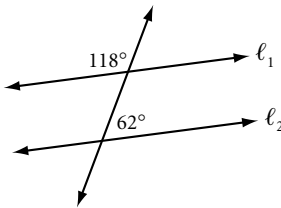

5.

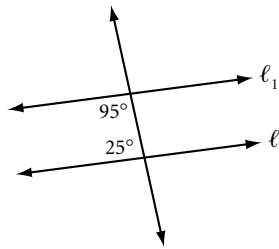

6.

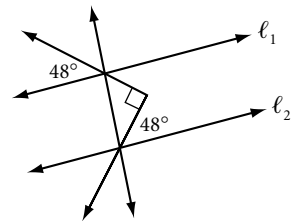

7. Find each angle measure.

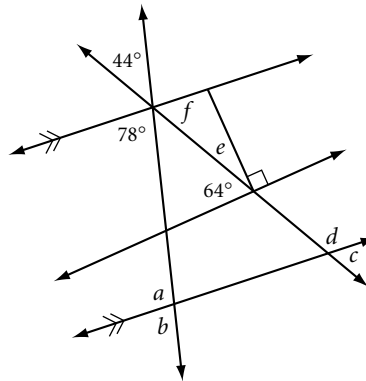

8. Find x .

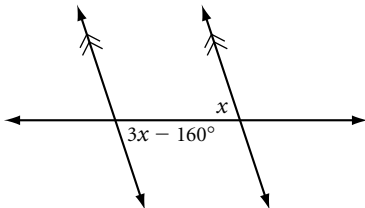

9. Find x and y .

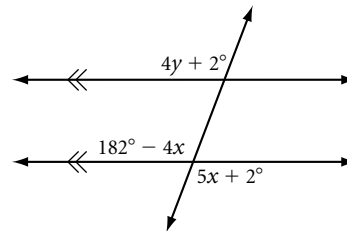

Lesson 3.1 • Duplicating Segments and Angles

Name _____ Period _____ Date _____

In Exercises 1–3, use the segments and angles below. Complete the constructions on a separate piece of paper.

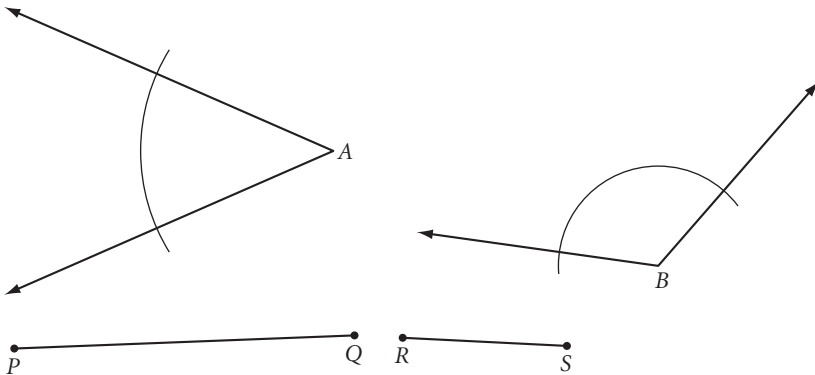

1. Using only a compass and straightedge, duplicate each segment and angle. There is an arc in each angle to help you.
2. Construct a line segment with length $3PQ - 2RS$.
3. Duplicate the two angles so that the angles have the same vertex and share a common side, and the nonshared side of one angle falls inside the other angle. Then use a protractor to measure the three angles you created. Write an equation relating their measures.
4. Use a compass and straightedge to construct an isosceles triangle with two sides congruent to \overline{AB} and base congruent to \overline{CD} .



5. Repeat Exercise 4 with patty paper and a straightedge.
6. Construct an equilateral triangle with sides congruent to \overline{CD} .



Lesson 3.2 • Constructing Perpendicular Bisectors

Name _____ Period _____ Date _____

For Exercises 1–6, construct the figures on a separate sheet of paper using only a compass and a straightedge.

1. Draw a segment and construct its perpendicular bisector.
2. Construct two congruent segments that are the perpendicular bisectors of each other. Form a quadrilateral by connecting the four endpoints. What type of quadrilateral does this seem to be?
3. Duplicate \overline{AB} . Then construct a segment with length $\frac{5}{4}AB$.

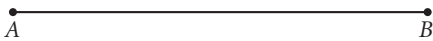

4. Draw a segment; label it \overline{CM} . \overline{CM} is a median of $\triangle ABC$. Construct $\triangle ABC$. Is $\triangle ABC$ unique? If not, construct a different triangle, $\triangle A'B'C'$, also having \overline{CM} as a median.
5. Draw a segment; label it \overline{PQ} . \overline{PQ} is a midsegment of $\triangle ABC$. Construct $\triangle ABC$. Is $\triangle ABC$ unique? If not, construct a different triangle, $\triangle A'B'C'$, also having \overline{PQ} as a midsegment.
6. Construct a right triangle. Label it $\triangle ABC$ with right angle B . Construct median \overline{BD} . Compare BD , AD , and CD .
7. Complete each statement as fully as possible.
 - a. L is equidistant from _____.
 - b. M is equidistant from _____.
 - c. N is equidistant from _____.
 - d. O is equidistant from _____.

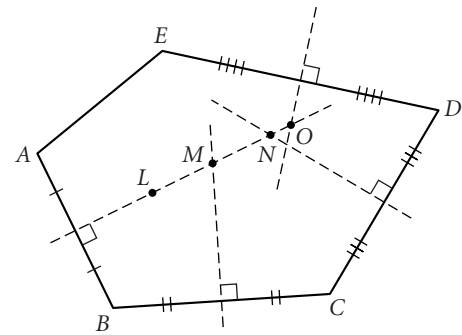

Lesson 3.3 • Constructing Perpendiculars to a Line

Name _____ Period _____ Date _____

For Exercises 1–5, decide whether each statement is true or false. If the statement is false, explain why or give a counterexample.

1. In a triangle, an altitude is shorter than either side from the same vertex.
2. In a triangle, an altitude is shorter than the median from the same vertex.
3. In a triangle, if a perpendicular bisector of a side and an altitude coincide, then the triangle is isosceles.
4. Exactly one altitude lies outside a triangle.
5. The intersection of the perpendicular bisectors of the sides lies inside the triangle.

For Exercises 6 and 7, use patty paper. Attach your patty paper to your worksheet.

6. Construct a right triangle. Construct the altitude from the right angle to the opposite side.
7. Mark two points, P and Q . Fold the paper to construct square $PQRS$.

Use your compass and straightedge and the definition of distance to complete Exercises 8 and 9 on a separate sheet of paper.

8. Construct a rectangle with sides equal in length to \overline{AB} and \overline{CD} .

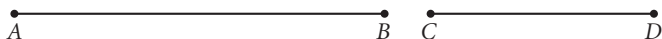

9. Construct a large equilateral triangle. Let P be any point inside the triangle. Construct \overline{WX} equal in length to the sum of the distances from P to each of the sides. Let Q be any other point inside the triangle. Construct \overline{YZ} equal in length to the sum of the distances from Q to each side. Compare WX and YZ .

Lesson 3.4 • Constructing Angle Bisectors

Name _____ Period _____ Date _____

1. Complete each statement as fully as possible.
 - a. M is equidistant from _____.
 - b. P is equidistant from _____.
 - c. Q is equidistant from _____.
 - d. R is equidistant from _____.

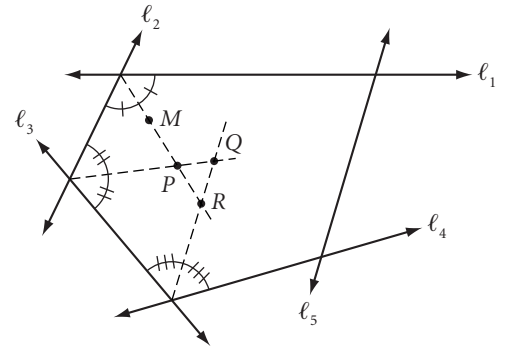

2. If the converse of the Angle Bisector Conjecture is true, what can you conclude about this figure?

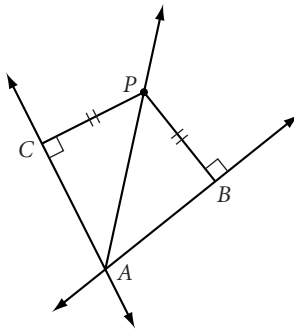

3. If BE bisects $\angle ABD$, find x and $m\angle ABE$.

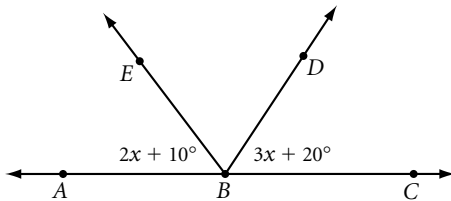

4. Draw an obtuse angle. Use a compass and straightedge to construct the angle bisector. Draw another obtuse angle and fold to construct the angle bisector.
5. Draw a large triangle on patty paper. Fold to construct the three angle bisectors. What do you notice?

For Exercises 6 and 7, construct a figure with the given specifications using a straightedge and compass or patty paper. Use additional sheets of paper to show your work.

6. Using only your compass and straightedge, construct an isosceles right triangle.
7. Construct right triangle RGH with right angle R . Construct median \overline{RM} , perpendicular \overline{MN} from M to \overline{RG} , and perpendicular \overline{MO} from M to \overline{RH} . Compare RN and GN , and compare RO and HO .

Lesson 3.5 • Constructing Parallel Lines

Name _____ Period _____ Date _____

For Exercises 1–6, construct a figure with the given specifications using a straightedge and compass or patty paper. Use additional sheets of paper to show your work.

1. Draw a line and a point not on the line. Use a compass and straightedge to construct a line through the given point parallel to the given line.
2. Repeat Exercise 1, but draw the line and point on patty paper and fold to construct the parallel line.
3. Use a compass and straightedge to construct a parallelogram.
4. Use patty paper and a straightedge to construct an isosceles trapezoid.
5. Construct a rhombus with sides equal in length to \overline{AB} and having an angle congruent to $\angle P$.

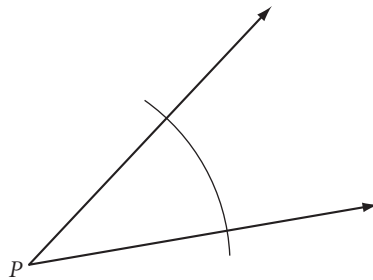
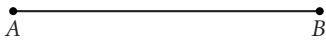

6. Construct trapezoid $ZOID$ with \overline{ZO} and \overline{ID} as nonparallel sides and \overline{AB} as the distance between the parallel sides.

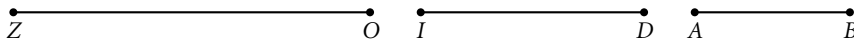

Lesson 3.6 • Construction Problems

Name _____ Period _____ Date _____

For Exercises 1–5, construct a figure with the given specifications using either a compass and straightedge or patty paper. Use additional sheets of paper to show your work.

1. Construct kite $KITE$ using these parts.

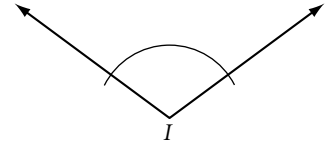
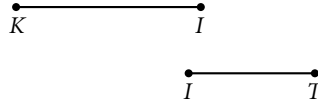

2. Construct a rectangle with perimeter the length of this segment.

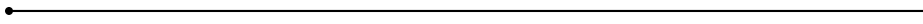

3. Construct a rectangle with this segment as its diagonal.



4. Draw obtuse $\triangle OBT$. Construct and label the three altitudes \overline{OU} , \overline{BS} , and \overline{TE} .

5. Construct a triangle congruent to $\triangle ABC$. Describe your steps.

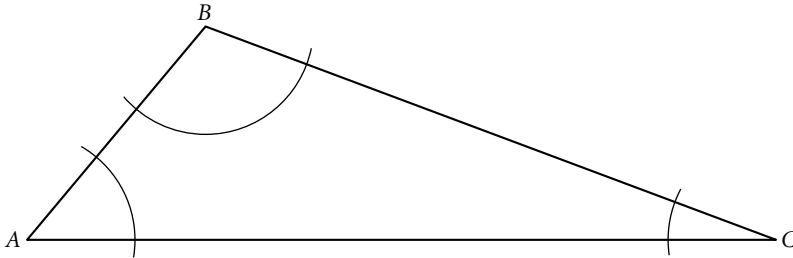

In Exercises 6–8, construct a triangle using the given parts. Then, if possible, construct a different (noncongruent) triangle using the same parts.

6.

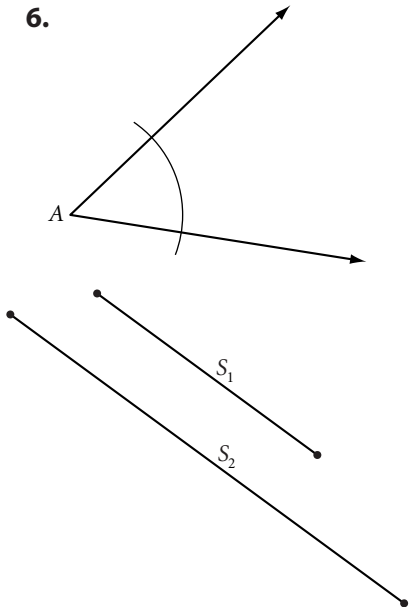

7.

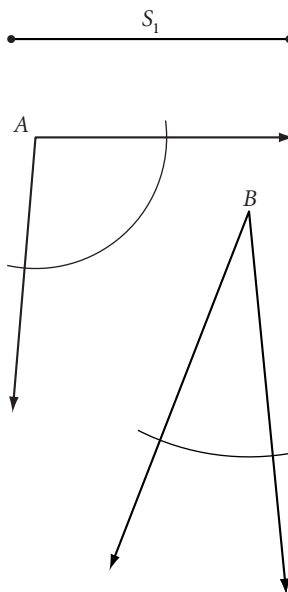

8.

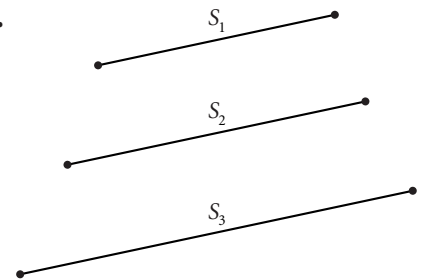

Lesson 3.7 • Constructing Points of Concurrency

Name _____ Period _____ Date _____

For Exercises 1 and 2, make a sketch and explain how to find the answer.

1. A circular revolving sprinkler needs to be set up to water every part of a triangular garden. Where should the sprinkler be located so that it reaches all of the garden, but doesn't spray farther than necessary?
2. You need to supply electric power to three transformers, one on each of three roads enclosing a large triangular tract of land. Each transformer should be the same distance from the power-generation plant and as close to the plant as possible. Where should you build the power plant, and where should you locate each transformer?

For Exercises 3–5, construct a figure with the given specifications using a compass and straightedge. Use additional sheets of paper to show your work.

3. Draw an obtuse triangle. Construct the inscribed and the circumscribed circles.
4. Construct an equilateral triangle. Construct the inscribed and the circumscribed circles. How does this construction differ from Exercise 3?
5. Construct two obtuse, two acute, and two right triangles. Locate the circumcenter of each triangle. Make a conjecture about the relationship between the location of the circumcenter and the measure of the angles.

Lesson 3.8 • The Centroid

Name _____ Period _____ Date _____

For Exercises 1–3, use additional sheets of paper to show your work.

1. Draw a large acute triangle. Construct the centroid.
2. Construct a regular hexagon and locate its center of gravity.
3. Use a ruler and compass to find the center of gravity of a sheet-metal triangle with sides measuring 6 cm, 8 cm, and 10 cm. How far is the center from each vertex, to the nearest tenth of a centimeter?
4. $\triangle ABC$ has vertices $A(9, 12)$, $B(-3, 2)$, and $C(3, -2)$. Find the coordinates of the centroid.

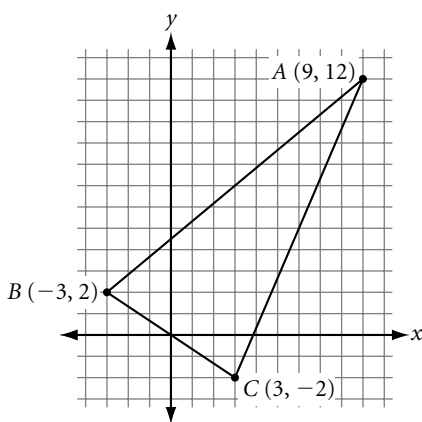

5. $PL = 24$, $QC = 10$, and $KC = 7$. Find PC , CL , QM , and CR .

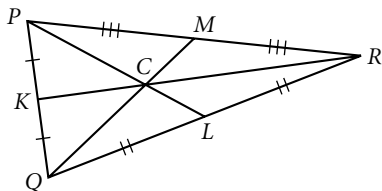

6. Identify each statement as describing the incenter, circumcenter, orthocenter, or centroid.
 - a. _____ The point equally distant from the three sides of a triangle.
 - b. _____ The center of gravity of a thin metal triangle.
 - c. _____ The point equidistant from the three vertices.
 - d. _____ The intersection of the perpendicular bisectors of the sides of a triangle.
 - e. _____ The intersection of the altitudes of a triangle.
 - f. _____ The intersection of the angle bisectors of a triangle.
 - g. _____ The intersection of the medians of a triangle.

Lesson 4.1 • Triangle Sum Conjecture

Name _____ Period _____ Date _____

In Exercises 1–9, determine the angle measures.

1. $p =$ _____, $q =$ _____

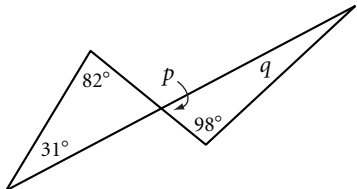

2. $x =$ _____, $y =$ _____

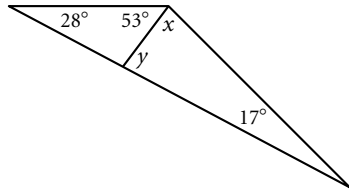

3. $a =$ _____, $b =$ _____

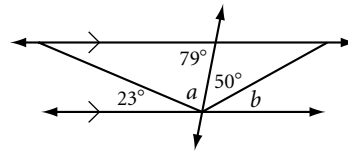

4. $r =$ _____, $s =$ _____,

$t =$ _____

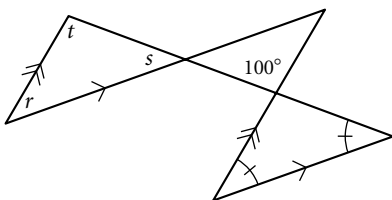

5. $x =$ _____, $y =$ _____

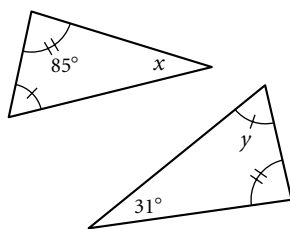

6. $y =$ _____

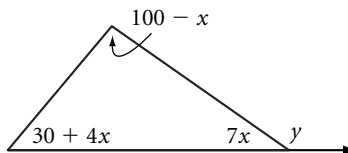

7. $s =$ _____

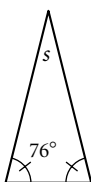

8. $m =$ _____

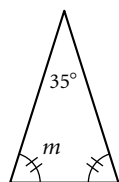

9. $m\angle P =$ _____

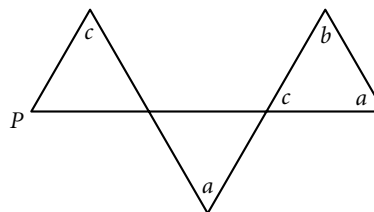

10. Find the measure of $\angle QPT$.

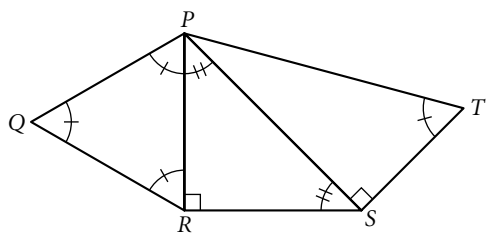

11. Find the sum of the measures of the marked angles.

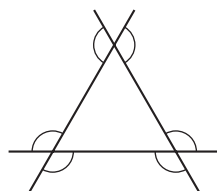

12. Use the diagram to explain why $\angle A$ and $\angle B$ are complementary.

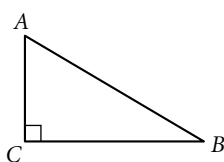

13. Use the diagram to explain why $m\angle A + m\angle B = m\angle C + m\angle D$.

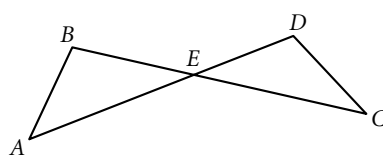

Lesson 4.2 • Properties of Isosceles Triangles

Name _____ Period _____ Date _____

In Exercises 1–3, find the angle measures.

1. $m\angle T =$ _____

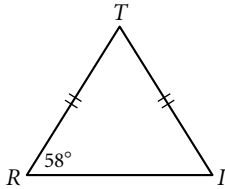

2. $m\angle G =$ _____

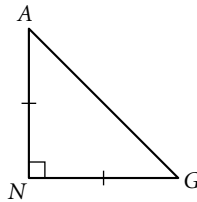

3. $x =$ _____

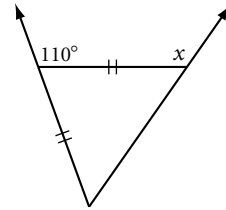

In Exercises 4–6, find the measures.

4. $m\angle A =$ _____, perimeter of $\triangle ABC =$ _____

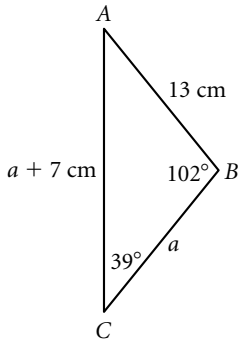

5. The perimeter of $\triangle LMO$ is 536 m. $LM =$ _____, $m\angle M =$ _____

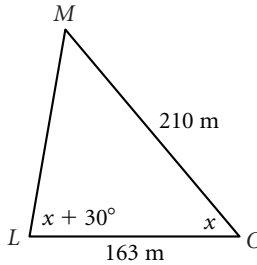

6. The perimeter of $\triangle QRS$ is 344 cm. $m\angle Q =$ _____, $QR =$ _____

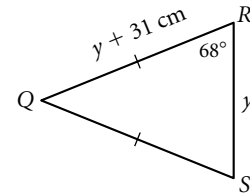

7. a. Name the angle(s) congruent to $\angle DAB$.

b. Name the angle(s) congruent to $\angle ADB$.

c. What can you conclude about \overline{AD} and \overline{BC} ? Why?

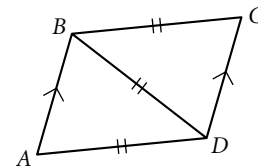

8. $x =$ _____, $y =$ _____

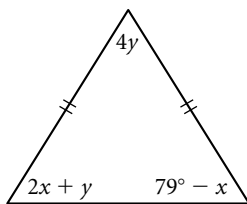

9. $PR = QR$ and $QS = RS$. If $m\angle RSQ = 120^\circ$, what is $m\angle QPR$?

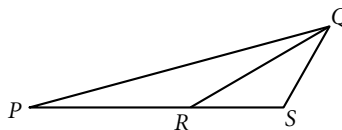

10. Use the diagram to explain why $\triangle PQR$ is isosceles.

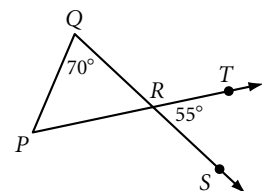

Lesson 4.4 • Are There Congruence Shortcuts?

Name _____ Period _____ Date _____

In Exercises 1–3, name the conjecture that leads to each congruence.

1. $\triangle PAT \cong \triangle IMT$

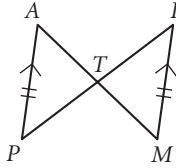

2. $\triangle SID \cong \triangle JAN$

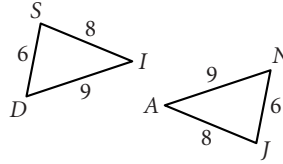

3. \overline{TS} bisects \overline{MA} , $\overline{MT} \cong \overline{AT}$, and $\triangle MST \cong \triangle AST$

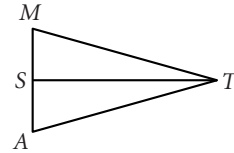

In Exercises 4–9, name a triangle congruent to the given triangle and state the congruence conjecture. If you cannot show any triangles to be congruent from the information given, write “cannot be determined” and redraw the triangles so that they are clearly not congruent.

4. M is the midpoint of \overline{AB} and \overline{PQ} .

$\triangle APM \cong \triangle$ _____

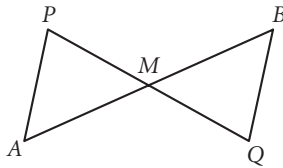

5. $KITE$ is a kite with $KI = TI$.

$\triangle KIE \cong \triangle$ _____

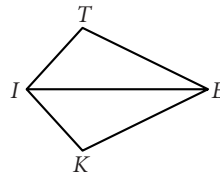

6. $\triangle ABC \cong$ _____

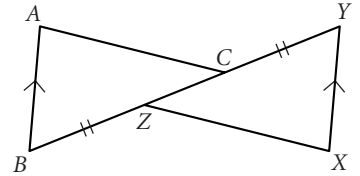

7. $\triangle MON \cong$ _____

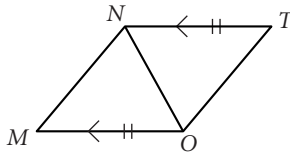

8. $\triangle SQR \cong$ _____

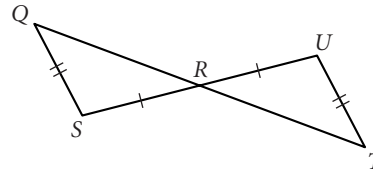

9. $\triangle TOP \cong$ _____

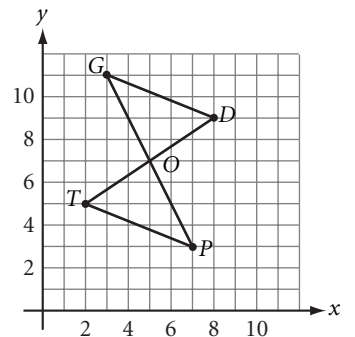

In Exercises 10–12, use a compass and a straightedge or patty paper and a straightedge to construct a triangle with the given parts. Then, if possible, construct a different (noncongruent) triangle with the same parts. If it is not possible, explain why not.

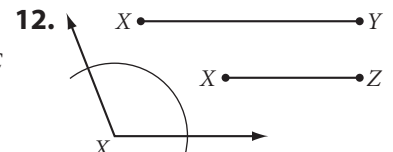
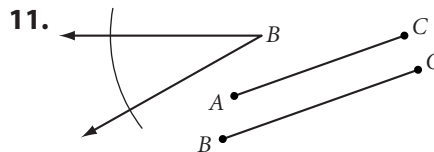
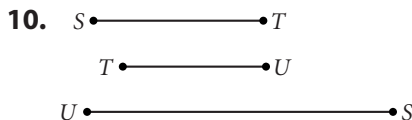

Lesson 4.5 • Are There Other Congruence Shortcuts?

Name _____ Period _____ Date _____

In Exercises 1–6, name a triangle congruent to the given triangle and state the congruence conjecture. If you cannot show any triangles to be congruent from the information given, write “cannot be determined” and explain why.

1. $\triangle PIT \cong \triangle$ _____

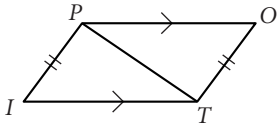

2. $\triangle XVW \cong \triangle$ _____

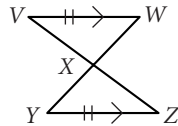

3. $\triangle ECD \cong \triangle$ _____

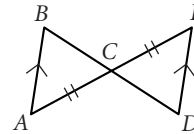

4. \overline{PS} is the angle bisector of $\angle QPR$.

$\triangle PQS \cong \triangle$ _____

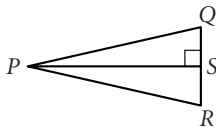

5. $\triangle ACN \cong \triangle$ _____

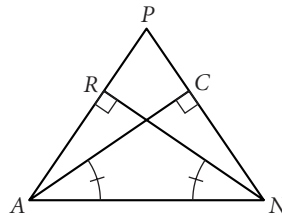

6. $EFGH$ is a parallelogram.
 $GQ = EQ$.

$\triangle EQL \cong \triangle$ _____

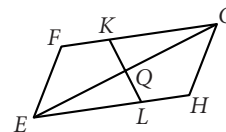

7. The perimeter of $\triangle QRS$ is 350 cm.
Is $\triangle QRS \cong \triangle MOL$? Explain.

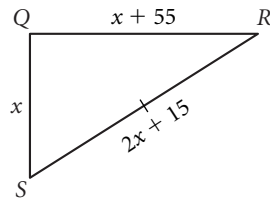
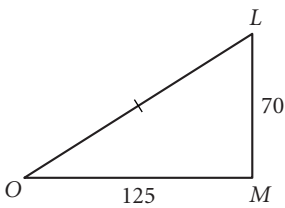

8. The perimeter of $\triangle TUV$ is 95 cm.
Is $\triangle TUV \cong \triangle WXV$? Explain.

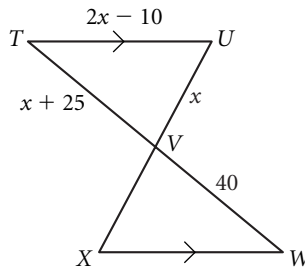

In Exercises 9 and 10, construct a triangle with the given parts. Then, if possible, construct a different (noncongruent) triangle with the same parts. If it is not possible, explain why not.

9. P ————— Q

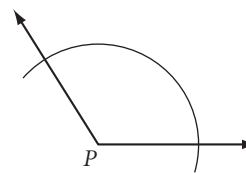
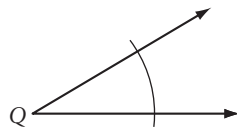

10. A ————— B

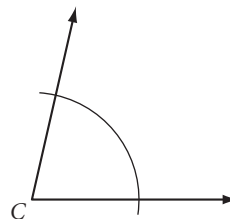
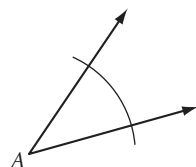

Lesson 4.6 • Corresponding Parts of Congruent Triangles

Name _____ Period _____ Date _____

1. Give the shorthand name for each of the four triangle congruence conjectures.

In Exercises 2–5, use the figure at right to explain why each congruence is true. $WXYZ$ is a parallelogram.

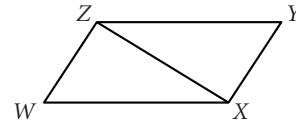

2. $\angle WXZ \cong \angle YZX$
3. $\angle WZX \cong \angle YXZ$
4. $\triangle WZX \cong \triangle YXZ$
5. $\angle W \cong \angle Y$

For Exercises 6 and 7, mark the figures with the given information. To demonstrate whether the segments or the angles indicated are congruent, determine that two triangles are congruent. Then state which conjecture proves them congruent.

6. M is the midpoint of \overline{WX} and \overline{YZ} . Is $\overline{YW} \cong \overline{ZX}$? Why?

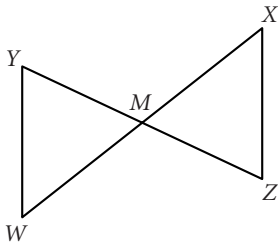

7. $\triangle ABC$ is isosceles and \overline{CD} is the bisector of the vertex angle. Is $\overline{AD} \cong \overline{BD}$? Why?

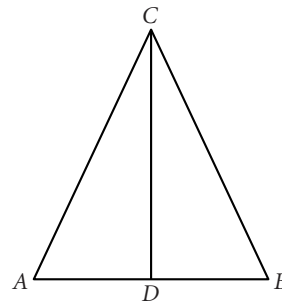

In Exercises 8 and 9, use the figure at right to write a paragraph proof for each statement.

8. $\overline{DE} \cong \overline{CF}$
9. $\overline{EC} \cong \overline{FD}$

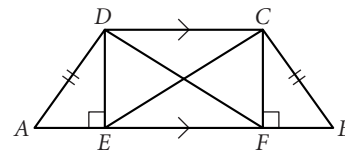

10. $TRAP$ is an isosceles trapezoid with $TP = RA$ and $\angle PTR \cong \angle ART$. Write a paragraph proof explaining why $\overline{TA} \cong \overline{RP}$.

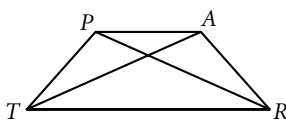

Lesson 4.7 • Flowchart Thinking

Name _____ Period _____ Date _____

Complete the flowchart for each proof.

1. **Given:** $\overline{PQ} \parallel \overline{SR}$ and $\overline{PQ} \cong \overline{SR}$

Show: $\overline{SP} \cong \overline{QR}$

Flowchart Proof

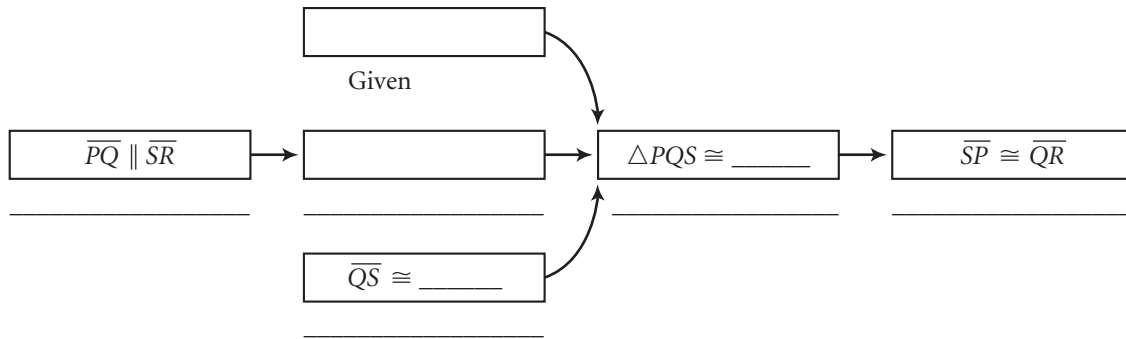
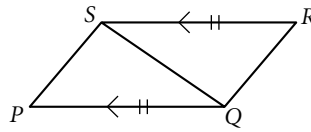

2. **Given:** Kite $KITE$ with $\overline{KE} \cong \overline{KI}$

Show: \overline{KT} bisects $\angle EKI$ and $\angle ETI$

Flowchart Proof

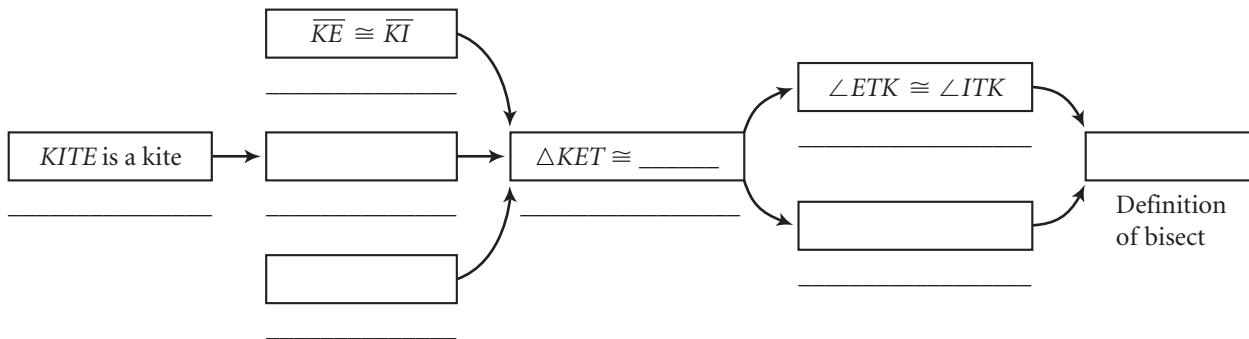
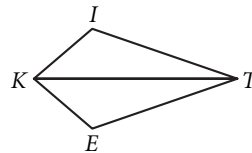

3. **Given:** $ABCD$ is a parallelogram

Show: $\angle A \cong \angle C$

Flowchart Proof

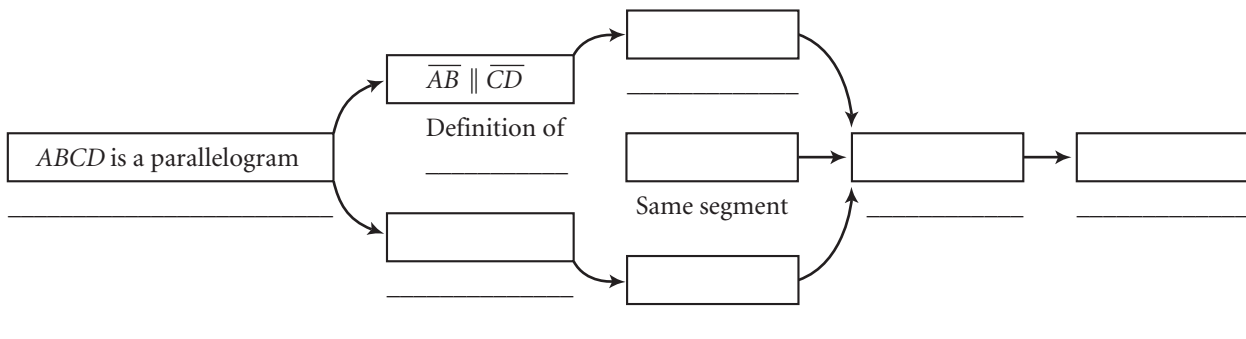
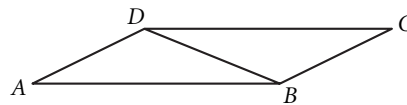

Lesson 4.8 • Proving Special Triangle Conjectures

Name _____ Period _____ Date _____

In Exercises 1–3, use the figure at right.

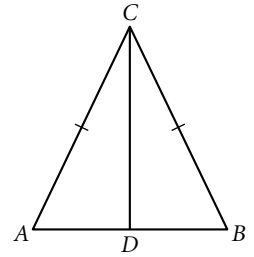

1. \overline{CD} is a median, perimeter $\triangle ABC = 60$, and $AC = 22$. $AD =$ _____
2. \overline{CD} is an angle bisector, and $m\angle A = 54^\circ$. $m\angle ACD =$ _____
3. \overline{CD} is an altitude, perimeter $\triangle ABC = 42$, $m\angle ACD = 38^\circ$, and $AD = 8$.
 $m\angle B =$ _____, $CB =$ _____
4. $\triangle EQU$ is equilateral.
 $m\angle E =$ _____
5. $\triangle ANG$ is equiangular
and perimeter $\triangle ANG = 51$.
 $AN =$ _____

6. $\triangle ABC$ is equilateral, $\triangle ACD$ is isosceles with base \overline{AC} ,
perimeter $\triangle ABC = 66$, and perimeter $\triangle ACD = 82$.
Perimeter $ABCD =$ _____

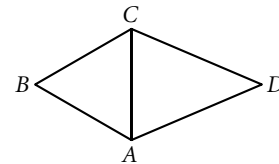

7. Complete a flowchart proof for this conjecture: In an isosceles triangle,
the altitude from the vertex angle is the median to the base.

Given: Isosceles $\triangle ABC$ with $\overline{AC} \cong \overline{BC}$ and altitude \overline{CD}

Show: \overline{CD} is a median

Flowchart Proof

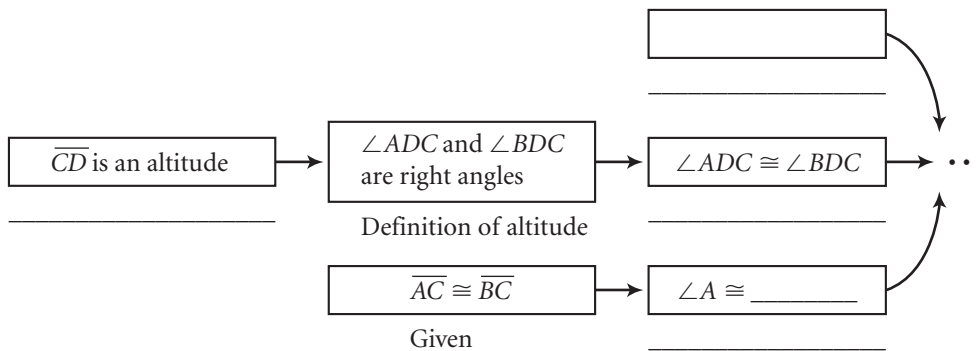
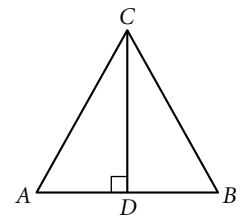

8. Write a flowchart proof for this conjecture: In an isosceles triangle, the
median to the base is also the angle bisector of the vertex angle.

Given: Isosceles $\triangle ABC$ with $\overline{AC} \cong \overline{BC}$ and median \overline{CD}

Show: \overline{CD} bisects $\angle ACB$

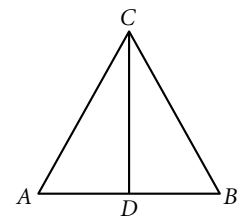

Lesson 5.1 • Polygon Sum Conjecture

Name _____ Period _____ Date _____

In Exercises 1 and 2, find each lettered angle measure.

1. $a = \underline{\hspace{1cm}}$, $b = \underline{\hspace{1cm}}$, $c = \underline{\hspace{1cm}}$,
 $d = \underline{\hspace{1cm}}$, $e = \underline{\hspace{1cm}}$

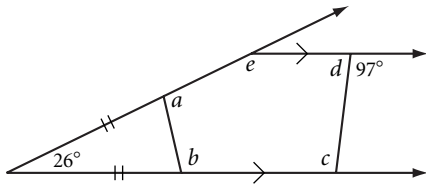

2. $a = \underline{\hspace{1cm}}$, $b = \underline{\hspace{1cm}}$, $c = \underline{\hspace{1cm}}$,
 $d = \underline{\hspace{1cm}}$, $e = \underline{\hspace{1cm}}$, $f = \underline{\hspace{1cm}}$

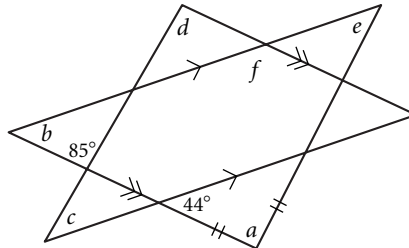

3. One exterior angle of a regular polygon measures 10° . What is the measure of each interior angle? How many sides does the polygon have?

4. The sum of the measures of the interior angles of a regular polygon is 2340° . How many sides does the polygon have?

5. $ABCD$ is a square. ABE is an equilateral triangle.

$x = \underline{\hspace{1cm}}$

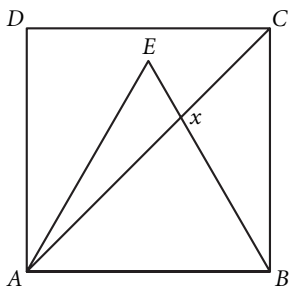

6. $ABCDE$ is a regular pentagon. $ABFG$ is a square.

$x = \underline{\hspace{1cm}}$

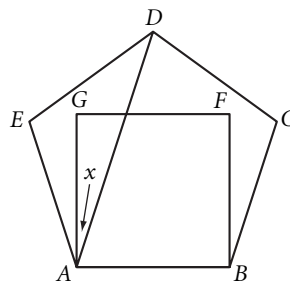

7. Use a protractor to draw pentagon $ABCDE$ with $m\angle A = 85^\circ$, $m\angle B = 125^\circ$, $m\angle C = 110^\circ$, and $m\angle D = 70^\circ$. What is $m\angle E$? Measure it, and check your work by calculating.

Lesson 5.2 • Exterior Angles of a Polygon

Name _____ Period _____ Date _____

- How many sides does a regular polygon have if each exterior angle measures 30° ?
- How many sides does a polygon have if the sum of the measures of the interior angles is 3960° ?
- If the sum of the measures of the interior angles of a polygon equals the sum of the measures of its exterior angles, how many sides does it have?
- If the sum of the measures of the interior angles of a polygon is twice the sum of its exterior angles, how many sides does it have?

In Exercises 5–7, find each lettered angle measure.

5. $a =$ _____, $b =$ _____

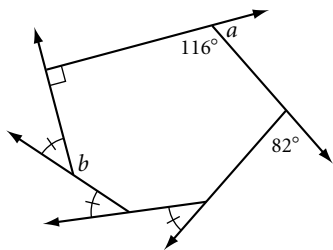

6. $a =$ _____, $b =$ _____

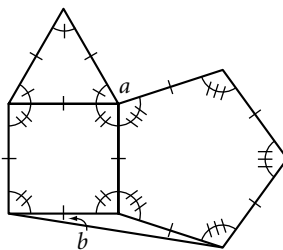

7. $a =$ _____, $b =$ _____,
 $c =$ _____

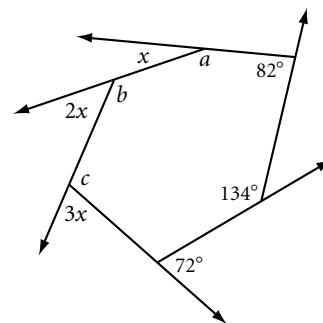

8. Find each lettered angle measure.

$a =$ _____
 $b =$ _____
 $c =$ _____
 $d =$ _____

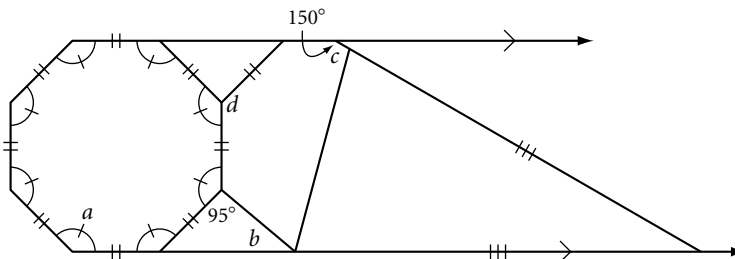

9. Construct an equiangular quadrilateral that is not regular.

Lesson 5.3 • Kite and Trapezoid Properties

Name _____ Period _____ Date _____

In Exercises 1–4, find each lettered measure.

1. Perimeter = 116. $x =$ _____

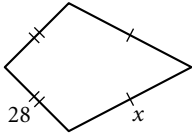

2. $x =$ _____, $y =$ _____

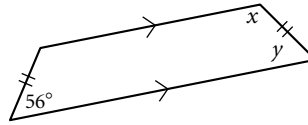

3. $x =$ _____, $y =$ _____

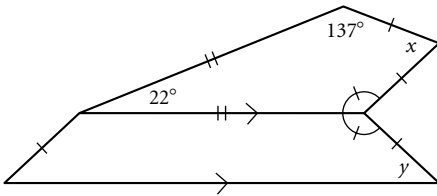

4. $x =$ _____, $y =$ _____

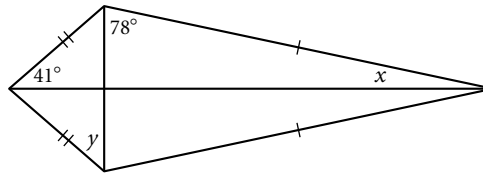

5. Perimeter $PQRS = 220$. $PS =$ _____

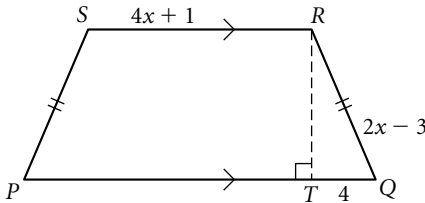

6. $b = 2a + 1$. $a =$ _____

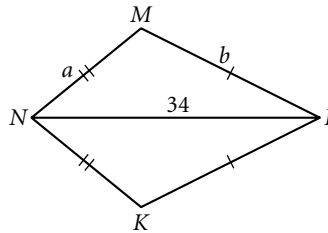

In Exercises 7 and 8, use the properties of kites and trapezoids to construct each figure. Use patty paper or a compass and a straightedge.

7. Construct an isosceles trapezoid given base \overline{AB} , $\angle B$, and distance between bases XY .

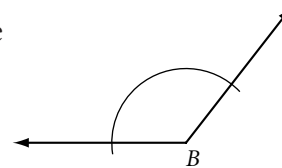
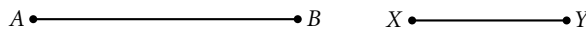

8. Construct kite $ABCD$ with \overline{AB} , \overline{BC} , and \overline{BD} .

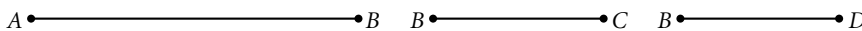

9. Write a paragraph or flowchart proof of the Converse of the Isosceles Trapezoid Conjecture. *Hint:* Draw \overline{AE} parallel to \overline{TP} with E on \overline{TR} .

Given: Trapezoid $TRAP$ with $\angle T \cong \angle R$

Show: $\overline{TP} \cong \overline{RA}$

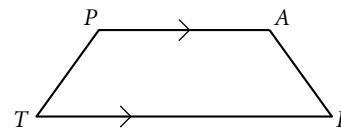

Lesson 5.4 • Properties of Midsegments

Name _____ Period _____ Date _____

In Exercises 1–3, each figure shows a midsegment.

1. $a = \underline{\hspace{2cm}}$, $b = \underline{\hspace{2cm}}$,
 $c = \underline{\hspace{2cm}}$

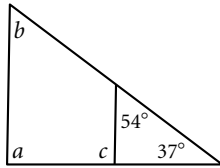

2. $x = \underline{\hspace{2cm}}$, $y = \underline{\hspace{2cm}}$,
 $z = \underline{\hspace{2cm}}$

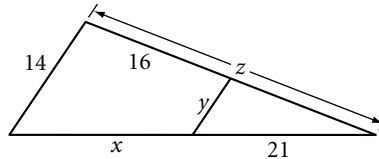

3. $x = \underline{\hspace{2cm}}$, $y = \underline{\hspace{2cm}}$,
 $z = \underline{\hspace{2cm}}$

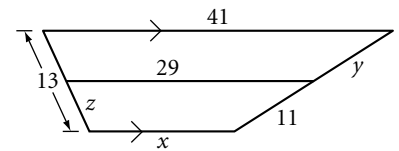

4. X , Y , and Z are midpoints. Perimeter $\triangle PQR = 132$, $RQ = 55$, and $PZ = 20$.

Perimeter $\triangle XYZ = \underline{\hspace{2cm}}$

$PQ = \underline{\hspace{2cm}}$

$ZX = \underline{\hspace{2cm}}$

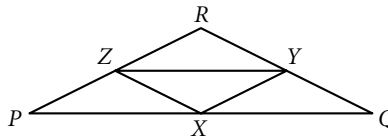

5. \overline{MN} is the midsegment. Find the coordinates of M and N . Find the slopes of \overline{AB} and \overline{MN} .

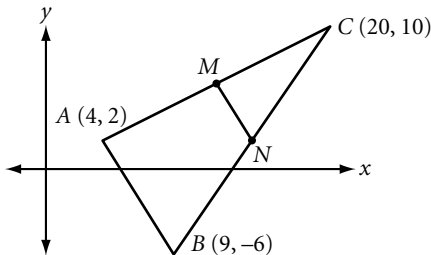

6. Explain how to find the width of the lake from A to B using a tape measure, but without using a boat or getting your feet wet.

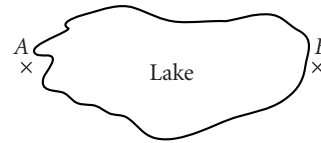

7. M , N , and O are midpoints. What type of quadrilateral is $AMNO$? How do you know? Give a flowchart proof showing that $\triangle ONC \cong \triangle MBN$.

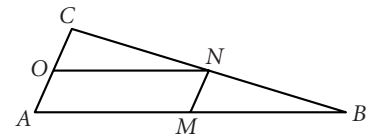

8. Give a paragraph or flowchart proof.

Given: $\triangle PQR$ with $PD = DF = FH = HR$
and $QE = EG = GI = IR$

Show: $\overline{HI} \parallel \overline{FG} \parallel \overline{DE} \parallel \overline{PQ}$

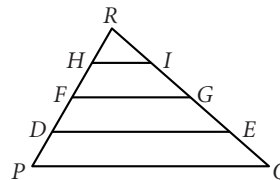

Lesson 5.5 • Properties of Parallelograms

Name _____ Period _____ Date _____

In Exercises 1–7, $ABCD$ is a parallelogram.

1. Perimeter $ABCD =$ _____

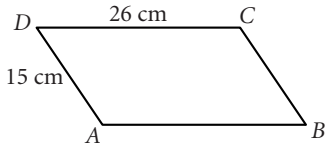

2. $AO = 11$, and $BO = 7$.

$AC =$ _____, $BD =$ _____

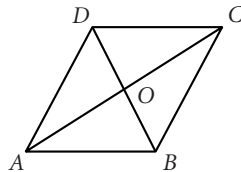

3. Perimeter $ABCD = 46$.

$AB =$ _____, $BC =$ _____

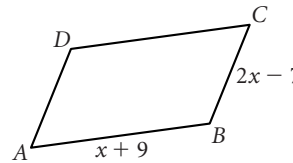

4. $a =$ _____, $b =$ _____,
 $c =$ _____

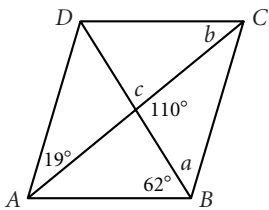

5. Perimeter $ABCD = 119$, and

$BC = 24$. $AB =$ _____

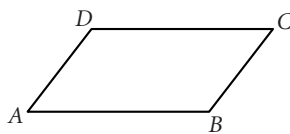

6. $a =$ _____, $b =$ _____,
 $c =$ _____

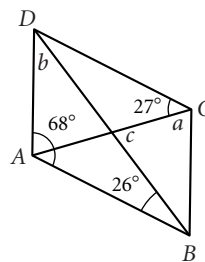

7. Perimeter $ABCD = 16x - 12$. $AD =$ _____

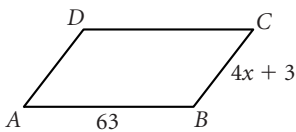

8. Ball B is struck at the same instant by two forces, \vec{F}_1 and \vec{F}_2 . Show the resultant force on the ball.

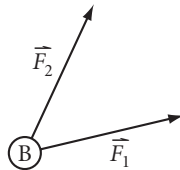

9. Find each lettered angle measure.

- | | |
|-------------|-------------|
| $a =$ _____ | $g =$ _____ |
| $b =$ _____ | $h =$ _____ |
| $c =$ _____ | $i =$ _____ |
| $d =$ _____ | $j =$ _____ |
| $e =$ _____ | $k =$ _____ |
| $f =$ _____ | |

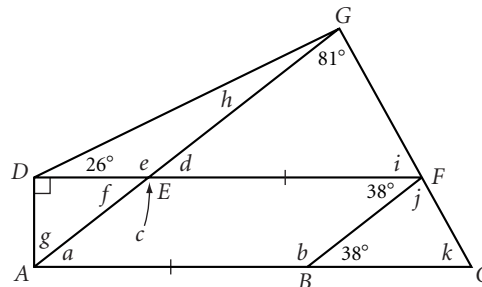

10. Construct a parallelogram with diagonals \overline{AC} and \overline{BD} .
Is your parallelogram unique? If not, construct a different (noncongruent) parallelogram.

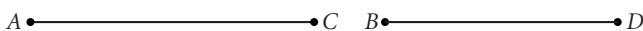

Lesson 5.6 • Properties of Special Parallelograms

Name _____ Period _____ Date _____

1. $PQRS$ is a rectangle and $OS = 16$.

$OQ =$ _____

$m\angle QRS =$ _____

$PR =$ _____

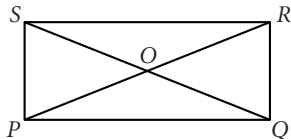

2. $KLMN$ is a square and $NM = 8$.

$m\angle OKL =$ _____

$m\angle MOL =$ _____

Perimeter $KLMN =$ _____

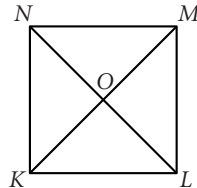

3. $ABCD$ is a rhombus, $AD = 11$, and $DO = 6$.

$OB =$ _____

$BC =$ _____

$m\angle AOD =$ _____

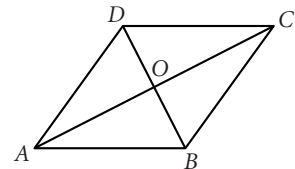

In Exercises 4–11, match each description with *all* the terms that fit it.

- | | | | |
|--------------|-----------------------|------------------|-----------------------|
| a. Trapezoid | b. Isosceles triangle | c. Parallelogram | d. Rhombus |
| e. Kite | f. Rectangle | g. Square | h. All quadrilaterals |
4. _____ Diagonals bisect each other.
 5. _____ Diagonals are perpendicular.
 6. _____ Diagonals are congruent.
 7. _____ Measures of interior angles sum to 360° .
 8. _____ Opposite sides are congruent.
 9. _____ Opposite angles are congruent.
 10. _____ Both diagonals bisect angles.
 11. _____ Diagonals are perpendicular bisectors of each other.

In Exercises 12 and 13, graph the points and determine whether $ABCD$ is a trapezoid, parallelogram, rectangle, or none of these.

12. $A(-4, -1), B(0, -3), C(4, 0), D(-1, 5)$

13. $A(0, -3), B(-1, 2), C(-3, 4), D(-2, -1)$

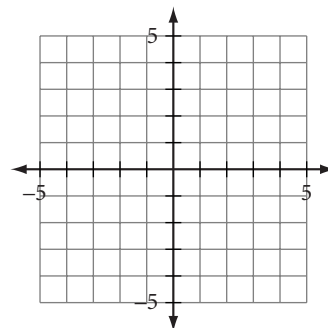
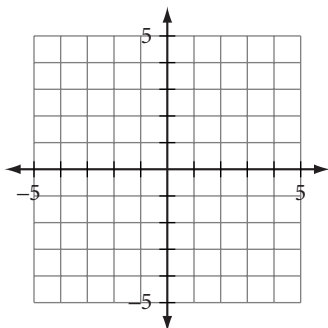

14. Construct rectangle $ABCD$ with diagonal \overline{AC} and $\angle CAB$.

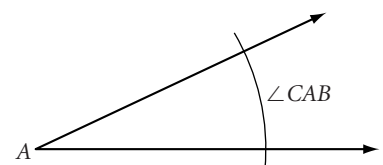
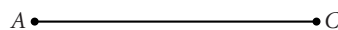

Lesson 5.7 • Proving Quadrilateral Properties

Name _____ Period _____ Date _____

Write or complete each flowchart proof.

1. **Given:** $ABCD$ is a parallelogram and $\overline{AP} \cong \overline{QC}$

Show: \overline{AC} and \overline{PQ} bisect each other

Flowchart Proof

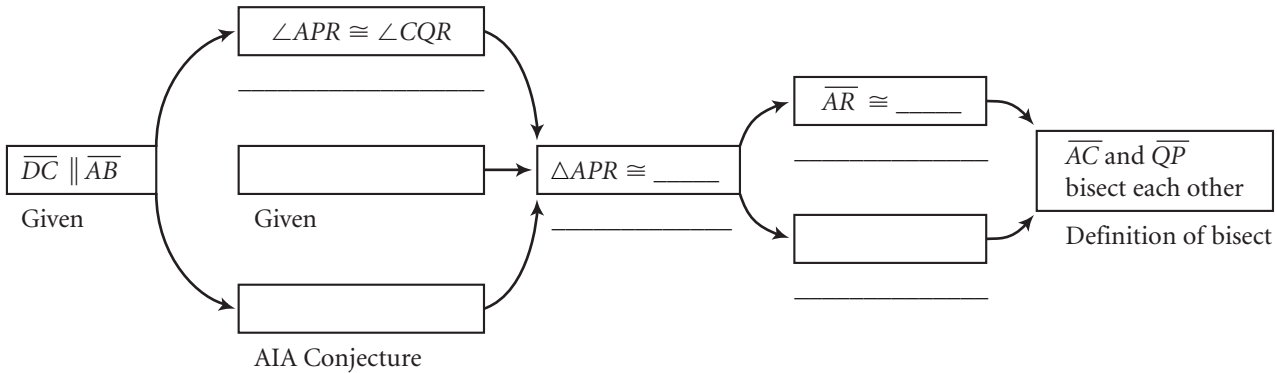
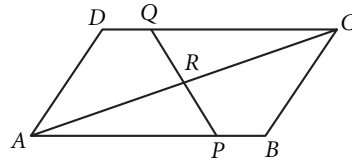

2. **Given:** Dart $ABCD$ with $\overline{AB} \cong \overline{BC}$ and $\overline{CD} \cong \overline{AD}$

Show: $\angle A \cong \angle C$

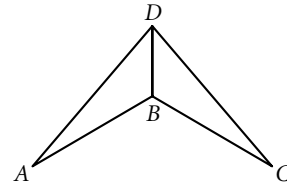

3. Show that the diagonals of a rhombus divide the rhombus into four congruent triangles.

Given: Rhombus $ABCD$

Show: $\triangle ABO \cong \triangle CBO \cong \triangle CDO \cong \triangle ADO$

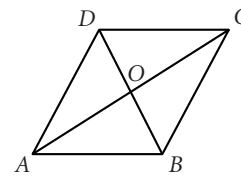

4. **Given:** Parallelogram $ABCD$, $\overline{BY} \perp \overline{AC}$, $\overline{DX} \perp \overline{AC}$

Show: $\overline{DX} \cong \overline{BY}$

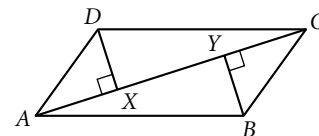

Lesson 6.1 • Tangent Properties

Name _____ Period _____ Date _____

1. Rays r and s are tangents. $w =$ _____

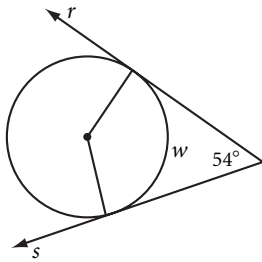

2. \overleftrightarrow{AB} is tangent to both circles and $m\widehat{AMC} = 295^\circ$. $m\angle BQX =$ _____

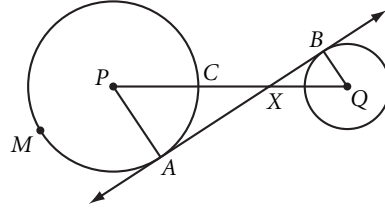

3. \overleftrightarrow{PQ} is tangent to two externally tangent noncongruent circles, M and N .

- a. $m\angle NQP =$ _____, $m\angle MPQ =$ _____
 b. What kind of quadrilateral is $MNQP$? Explain your reasoning.

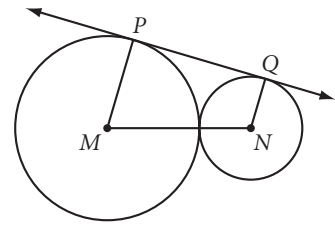

4. \overleftrightarrow{AT} is tangent to circle P . Find the equation of \overleftrightarrow{AT} .

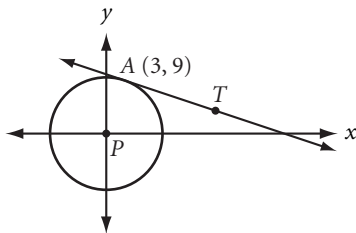

5. \overline{PA} , \overline{PB} , \overline{PC} , and \overline{PD} are tangents. Explain why $\overline{PA} \cong \overline{PD}$.

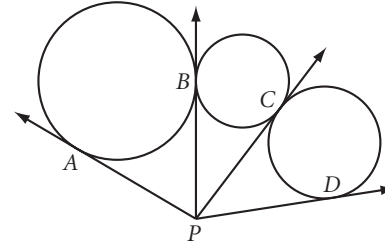

6. Circle A has diameter 16.4 cm. Circle B has diameter 6.7 cm.
 a. If A and B are internally tangent, what is the distance between their centers?
 b. If A and B are externally tangent, what is the distance between their centers?
7. Construct a circle, P . Pick a point, A , on the circle. Construct a tangent through A . Pick a point, T , on the tangent. Construct a second tangent to the circle through T .

Lesson 6.2 • Chord Properties

Name _____ Period _____ Date _____

In Exercises 1–6, find each unknown or write “cannot be determined.”

1. $a = \underline{\hspace{1cm}}$, $b = \underline{\hspace{1cm}}$, $c = \underline{\hspace{1cm}}$ 2. $w = \underline{\hspace{1cm}}$, $v = \underline{\hspace{1cm}}$ 3. $z = \underline{\hspace{1cm}}$

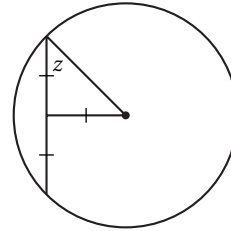
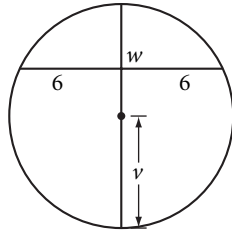
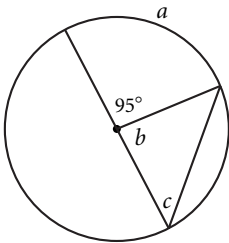

4. $w = \underline{\hspace{1cm}}$, $x = \underline{\hspace{1cm}}$, $y = \underline{\hspace{1cm}}$ 5. $w = \underline{\hspace{1cm}}$, $x = \underline{\hspace{1cm}}$, $y = \underline{\hspace{1cm}}$ 6. $x = \underline{\hspace{1cm}}$, $y = \underline{\hspace{1cm}}$

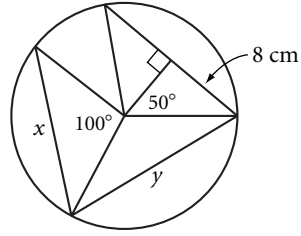
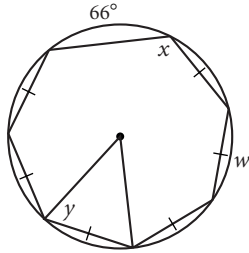
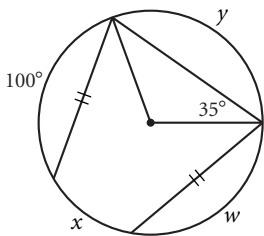

7. $\overline{AB} \cong \overline{AC}$. $\triangle AMON$ is a _____.
Justify your answer.
8. What's wrong with this picture?
9. Find the coordinates of P and M .

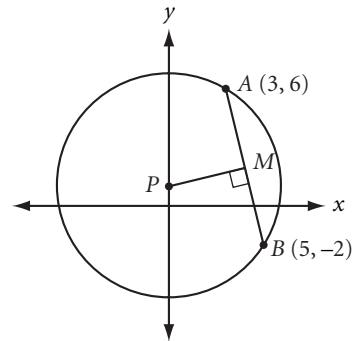
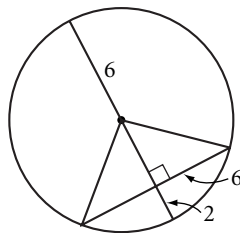
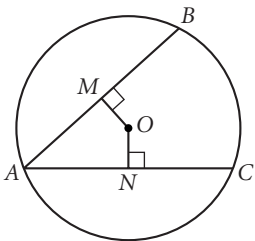

10. $m\widehat{AB} = \underline{\hspace{1cm}}$
 $m\widehat{ABC} = \underline{\hspace{1cm}}$
 $m\widehat{BAC} = \underline{\hspace{1cm}}$
 $m\widehat{ACB} = \underline{\hspace{1cm}}$

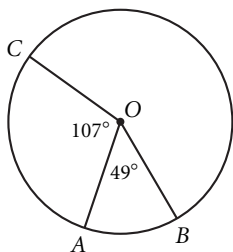

11. Trace part of a circle onto patty paper. Fold to find the center. Explain your method.

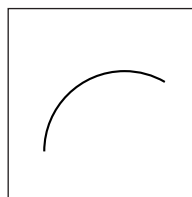

Lesson 6.3 • Arcs and Angles

Name _____ Period _____ Date _____

1. $m\widehat{XM} = 80^\circ$

$m\angle XNM = \underline{\hspace{2cm}}$

$m\widehat{XN} = \underline{\hspace{2cm}}$

$m\widehat{MN} = \underline{\hspace{2cm}}$

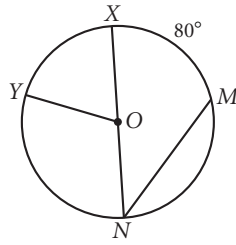

2. \overrightarrow{AB} is a tangent.

$x = \underline{\hspace{2cm}}$

$y = \underline{\hspace{2cm}}$

$z = \underline{\hspace{2cm}}$

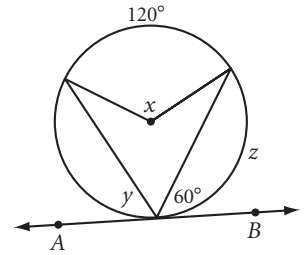

3. $a = \underline{\hspace{2cm}}$

$b = \underline{\hspace{2cm}}$

$c = \underline{\hspace{2cm}}$

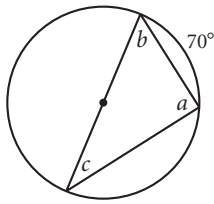

4. $a = \underline{\hspace{2cm}}$

$b = \underline{\hspace{2cm}}$

$c = \underline{\hspace{2cm}}$

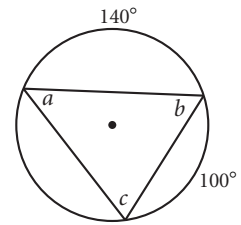

5. \overrightarrow{AB} and \overrightarrow{AC} are tangents.

$x = \underline{\hspace{2cm}}$

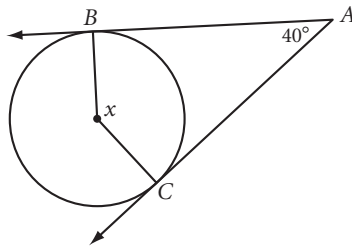

6. \overrightarrow{AD} is a tangent. \overline{AC} is a diameter.

$m\angle A = \underline{\hspace{2cm}}$

$m\widehat{AB} = \underline{\hspace{2cm}}$

$m\angle C = \underline{\hspace{2cm}}$

$m\widehat{CB} = \underline{\hspace{2cm}}$

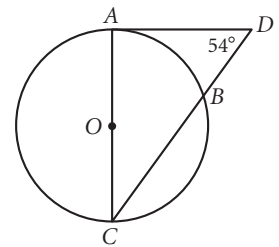

7. $m\widehat{AD} = \underline{\hspace{2cm}}$

$m\angle D = \underline{\hspace{2cm}}$

$m\widehat{AB} = \underline{\hspace{2cm}}$

$m\widehat{DAB} = \underline{\hspace{2cm}}$

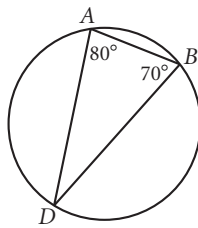

8. $p = \underline{\hspace{2cm}}$

$q = \underline{\hspace{2cm}}$

$r = \underline{\hspace{2cm}}$

$s = \underline{\hspace{2cm}}$

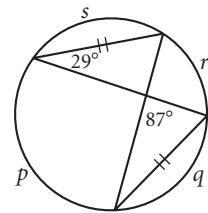

9. Find the lettered angle and arc measures. \overrightarrow{AT} and \overrightarrow{AZ} are tangents.

$a = \underline{\hspace{2cm}}$

$b = \underline{\hspace{2cm}}$

$c = \underline{\hspace{2cm}}$

$d = \underline{\hspace{2cm}}$

$e = \underline{\hspace{2cm}}$

$f = \underline{\hspace{2cm}}$

$g = \underline{\hspace{2cm}}$

$h = \underline{\hspace{2cm}}$

$j = \underline{\hspace{2cm}}$

$k = \underline{\hspace{2cm}}$

$m = \underline{\hspace{2cm}}$

$n = \underline{\hspace{2cm}}$

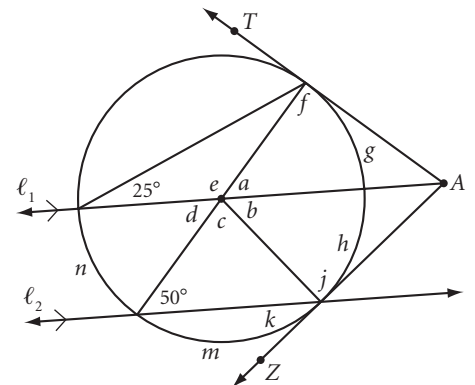

Lesson 6.4 • Proving Circle Conjectures

Name _____ Period _____ Date _____

In Exercises 1–4, complete each proof with a paragraph or a flowchart.

- 1. Given:** Circles O and P are externally tangent, with common tangents \overline{CD} and \overline{AB}

Show: \overline{AB} bisects \overline{CD} at X

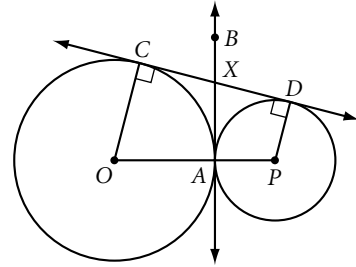

- 2. Given:** Circle O with diameter \overline{AB} and chord \overline{AD} . $\overline{OE} \parallel \overline{AD}$.

Show: $\widehat{DE} \cong \widehat{BE}$

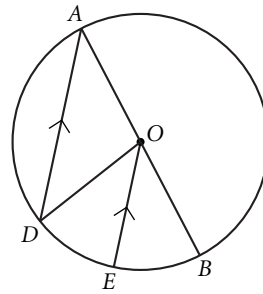

- 3. Given:** \overline{PQ} and \overline{RS} are tangent to both circles.

Show: $\overline{PQ} \cong \overline{RS}$.

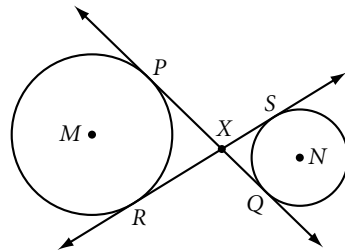

- 4. Prove the converse of the Chord Arcs Conjecture:** If two arcs in a circle are congruent, then their chords are congruent. *Hint:* Draw radii.

Given: $\widehat{AB} \cong \widehat{CD}$

Show: $\overline{AB} \cong \overline{CD}$

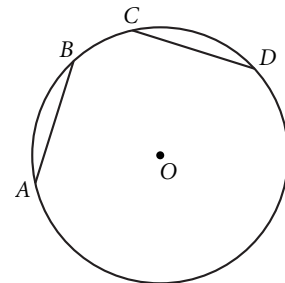

Lesson 6.5 • The Circumference/Diameter Ratio

Name _____ Period _____ Date _____

In Exercises 1–4, leave your answers in terms of π .

1. If $r = 10.5$ cm, find C .
2. If $C = 25\pi$ cm, find r .
3. What is the circumference of a circle whose radius is 30 cm?
4. What is the diameter of a circle whose circumference is 24π cm?

In Exercises 5–9, round your answer to the nearest 0.1 unit. Use the symbol \approx to show that your answer is an approximation.

5. If $d = 9.6$ cm, find C .
6. If $C = 132$ cm, find d and r .
7. A dinner plate fits snugly in a square box with perimeter 48 inches. What is the circumference of the plate?
8. Four saucers are part of the same set as the dinner plate in Exercise 7. Each has a circumference of 15.7 inches. Will they fit, side by side, in the same square box? If so, how many inches will there be between the saucers for padding?

9. \overrightarrow{AT} and \overrightarrow{AS} are tangents. $AT = 12$ cm. What is the circumference of circle O ?

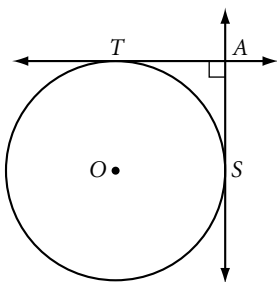

10. How can you use a large carpenter's square to find the circumference of a tree?

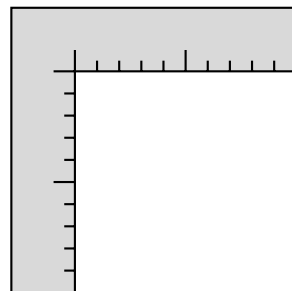

11. In order to increase the circumference of a circle from 16π cm to 20π cm, by how much must the diameter increase?

Lesson 6.6 • Around the World

Name _____ Period _____ Date _____

1. Alfonzo's Pizzeria bakes olive pieces in the outer crust of its 20-inch (diameter) pizza. There is at least one olive piece per inch of crust. How many olive pieces will you get in one slice of pizza? Assume the pizza is cut into eight slices.

2. To use the machine at right, you turn the crank, which turns the pulley wheel, which winds the rope and lifts the box. Through how many rotations must you turn the crank to lift the box 10 feet?

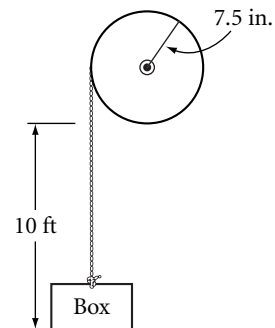

3. A satellite in *geostationary* orbit stays over the same spot on Earth. The satellite completes one orbit in the same time that Earth rotates once about its axis (23.93 hours). If the satellite's orbit has radius 4.23×10^7 m, calculate the satellite's orbital speed (tangential velocity) in meters per second.
4. You want to decorate the side of a cylindrical can by coloring a rectangular piece of paper and wrapping it around the can. The paper is 19 cm by 29 cm. Find the two possible diameters of the can to the nearest 0.01 cm. Assume the paper fits exactly.
5. As you sit in your chair, you are whirling through space with Earth as it moves around the sun. If the average distance from Earth to the sun is 1.4957×10^{11} m and Earth completes one revolution every 364.25 days, what is your "sitting" speed in space relative to the sun? Give your answer in km/h, rounded to the nearest 100 km/h.

Lesson 6.7 • Arc Length

Name _____ Period _____ Date _____

In Exercises 1–10, leave your answers in terms of π .

1. Length of \widehat{AB} = _____

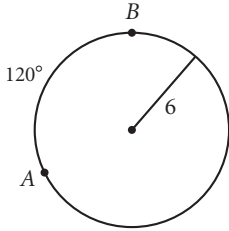

2. The circumference is 24π and $m\widehat{CD} = 60^\circ$. Length of \widehat{CD} = _____

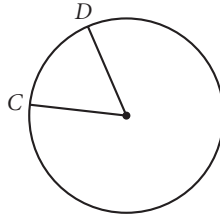

3. The length of \widehat{EF} is 5π . Radius = _____

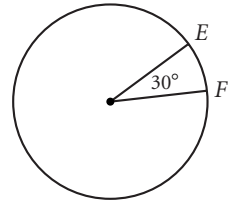

4. Length of \widehat{XY} = _____

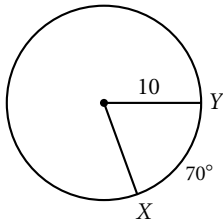

5. The radius is 20. Length of \widehat{AB} = _____

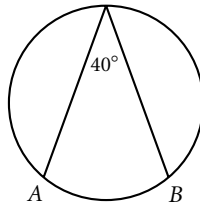

6. The circumference is 25π . Length of \widehat{AB} = _____

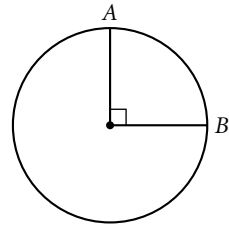

7. The diameter is 40. Length of \widehat{AC} = _____

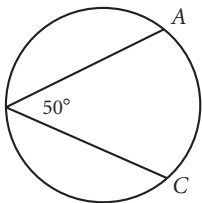

8. The length of \widehat{XY} is 14π . Diameter = _____

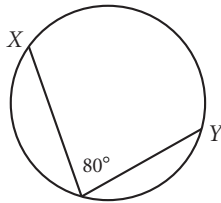

9. Length of \widehat{AB} = _____

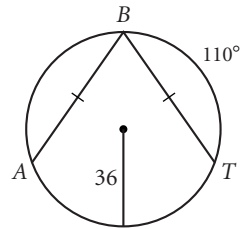

10. A circle has an arc with measure 80° and length 88π . What is the diameter of the circle?

Exploration • Intersecting Secants, Tangents, and Chords

Name _____ Period _____ Date _____

1. $x =$ _____

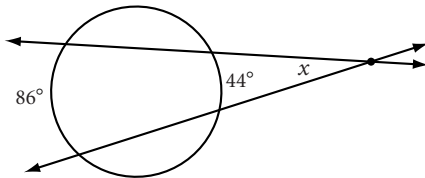

2. \overrightarrow{FC} is tangent to circle A at point C.
 $m\widehat{DC} =$ _____, $m\widehat{ED} =$ _____

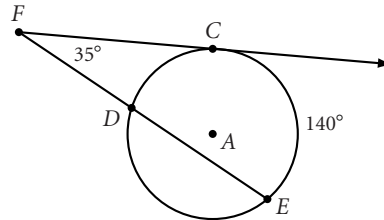

3. \overrightarrow{ED} and \overrightarrow{EC} are tangents.
 $m\widehat{DC} =$ _____, $m\angle DEC =$ _____

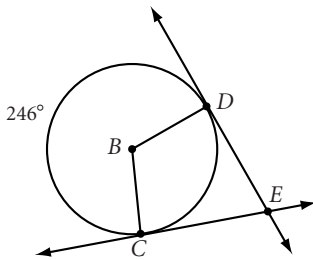

4. \overrightarrow{CE} is a tangent, $m\widehat{BC} = 150^\circ$
 $m\angle BCE =$ _____, $m\widehat{BAC} =$ _____

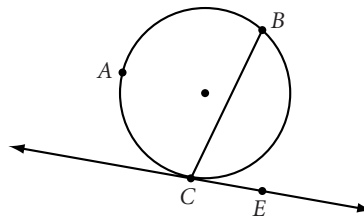

5. $x =$ _____, $y =$ _____, $z =$ _____

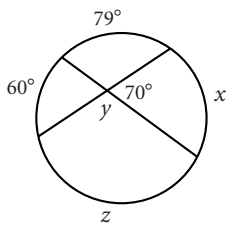

6. $x =$ _____, $y =$ _____, $z =$ _____

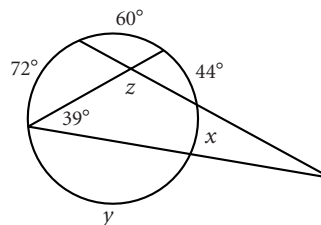

7. \overrightarrow{AB} and \overrightarrow{AC} are tangents.
 $x =$ _____, $y =$ _____, $z =$ _____

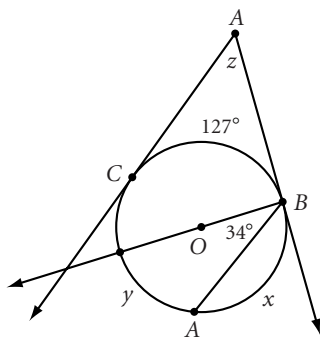

8. \overrightarrow{AB} is a tangent, $m\angle ABC = 75^\circ$
 $x =$ _____, $y =$ _____

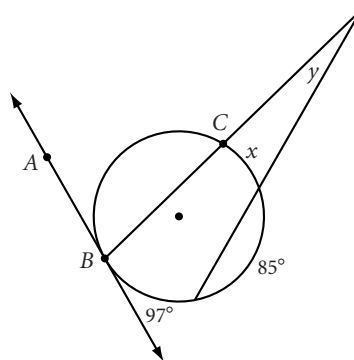

Lesson 7.1 • Transformations and Symmetry

Name _____ Period _____ Date _____

In Exercises 1–3, perform each transformation.

1. Reflect $\triangle TRI$ across line ℓ .

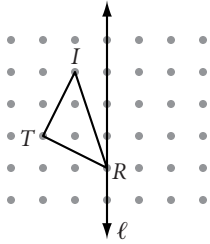

2. Rotate $PARL$ 270° clockwise about Q .

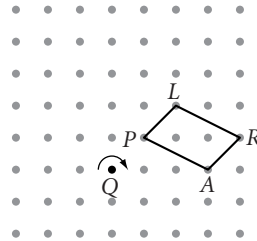

3. Translate $PENTA$ by the given vector.

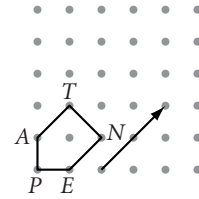

4. $ABCDE$ and its reflected image, $A'B'C'D'E'$, are shown below. Use construction tools to locate the line of reflection, ℓ . Explain your method.

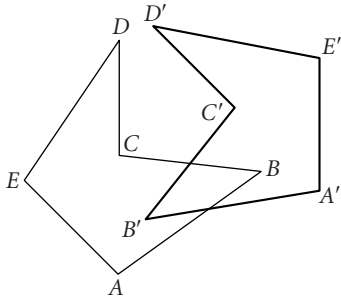

In Exercises 5–8, identify the type(s) of symmetry in each figure.

5. Equilateral triangle

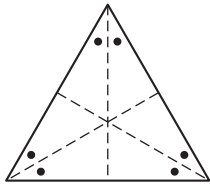

6. Rectangle



7. Isosceles triangle

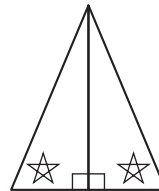

8. Square

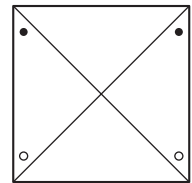

In Exercises 9–12, draw each polygon and identify the type(s) of symmetry in each. Draw all lines of reflection and mark centers of rotation.

9. Rhombus

10. Parallelogram

11. Isosceles trapezoid

12. Square

Lesson 7.2 • Properties of Isometries

Name _____ Period _____ Date _____

In Exercises 1–3, draw the image according to the rule and identify the type of transformation.

1. $(x, y) \rightarrow (-x, -y)$

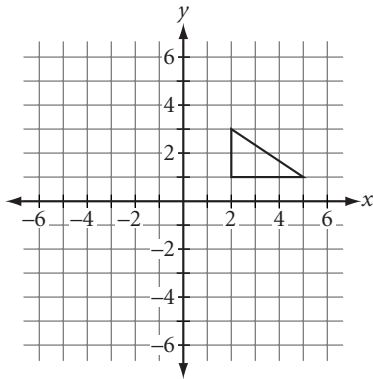

2. $(x, y) \rightarrow (x - 4, y + 6)$

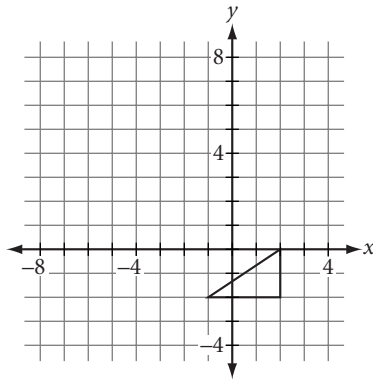

3. $(x, y) \rightarrow (4 - x, y)$

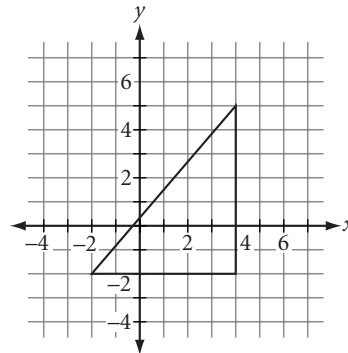

In Exercises 4 and 5, the Harbour High Geometry Class is holding a Fence Race. Contestants must touch each fence at some point as they run from S to F . Use your geometry tools to draw the shortest possible race path.

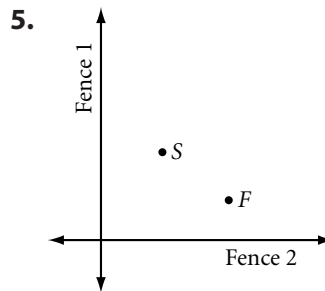
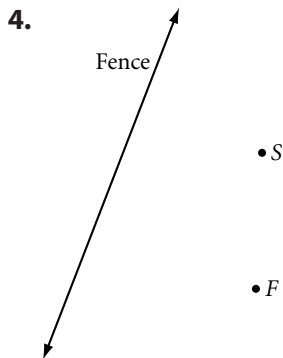

In Exercises 6–8, complete the ordered pair rule that transforms each triangle to its image. Identify the transformation. Find all missing coordinates.

6. $(x, y) \rightarrow (\underline{\hspace{1cm}}, \underline{\hspace{1cm}})$

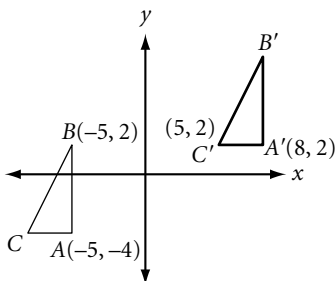

7. $(x, y) \rightarrow (\underline{\hspace{1cm}}, \underline{\hspace{1cm}})$

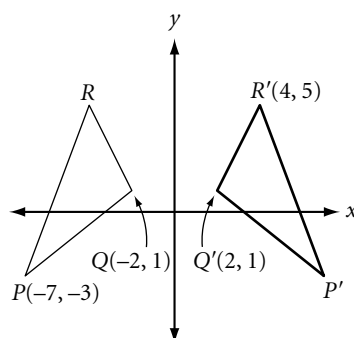

8. $(x, y) \rightarrow (\underline{\hspace{1cm}}, \underline{\hspace{1cm}})$

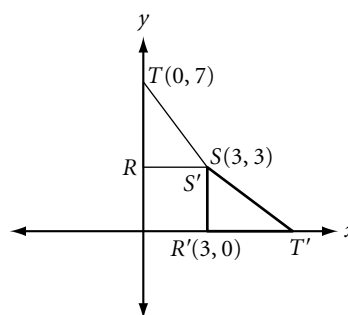

Lesson 7.3 • Compositions of Transformations

Name _____ Period _____ Date _____

In Exercises 1–8, name the single transformation that can replace the composition of each set of multiple transformations.

1. Translation by $\langle +4, +1 \rangle$, followed by $\langle +2, -3 \rangle$, followed by $\langle -8, +7 \rangle$
2. Rotation 60° clockwise, followed by 80° counterclockwise, followed by 25° counterclockwise all about the same center of rotation
3. Reflection across vertical line m , followed by reflection across vertical line n , where n is 8 units to the right of m
4. Reflection across vertical line p , followed by reflection across horizontal line q
5. Reflection across vertical line n , followed by reflection across vertical line m , where n is 8 units to the right of m
6. Reflection across horizontal line q , followed by reflection across vertical line p
7. Translation by $\langle +6, 0 \rangle$, followed by reflection across the y -axis
8. Reflection across the y -axis, followed by translation by $\langle +6, 0 \rangle$

In Exercises 9–11, copy the figure onto your paper and use your geometry tools to perform the given transformation.

9. Locate P' , the reflected image across \overline{OR} , and P'' , the reflected image of P' across \overline{OT} . Find $m\angle ROT$ and give a single transformation that maps P to P'' .
10. Locate P' , the reflected image across k , and P'' , the reflected image of P' across ℓ . Find the distance between ℓ and k and give a single transformation that maps P to P'' .
11. Draw five glide-reflected images of the triangle.

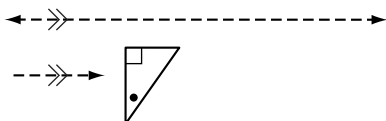
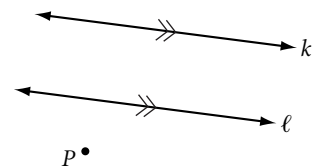
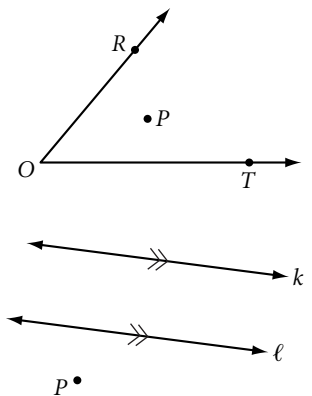

Lesson 7.4 • Tessellations with Regular Polygons

Name _____ Period _____ Date _____

1. Find n .

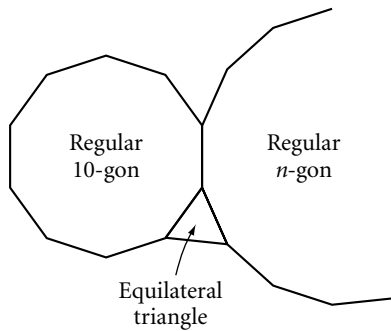

2. Find n .

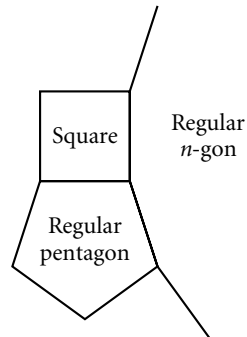

3. What is a regular tessellation? Sketch an example to illustrate your explanation.

4. What is a 1-uniform tiling? Sketch an example of a 1-uniform tiling that is not a regular tessellation.

5. Give the numerical name for the tessellation at right.

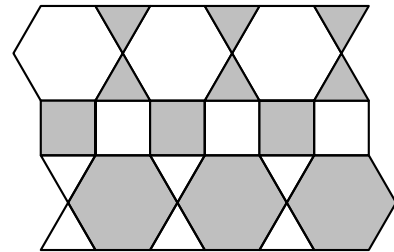

6. Use your geometry tools to draw the 4.8^2 tessellation.

Lessons 7.5–7.8 • Tessellations

Name _____ Period _____ Date _____

1. Trace the quadrilateral at right (or draw a similar one). Make the outline dark. Set another piece of paper on top of the quadrilateral and, by tracing, create a tessellation. (*Hint:* Trace vertices and use a straightedge to connect them.)

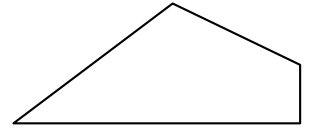

2. On dot paper, draw a small concave quadrilateral (vertices on dots). Allow no more than three dots inside the figure. Tessellate the entire paper with your quadrilateral. Color and shade your tessellation.

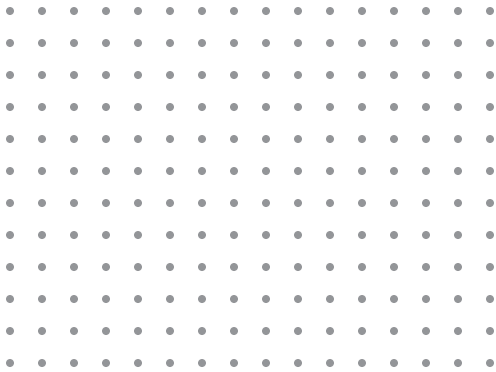

3. In *non-edge-to-edge tilings*, the vertices of the polygons do not have to coincide, as in these wooden deck patterns. Use graph paper to create your own non-edge-to-edge tiling.

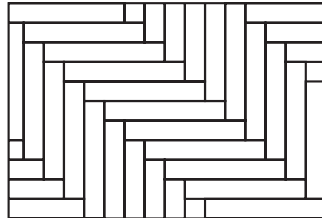
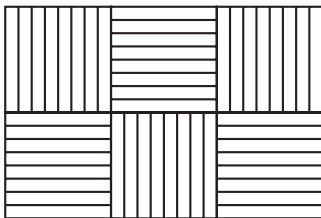

4. Use your geometry tools to draw a parallelogram. Draw squares on each side. Create a tessellation by duplicating your parallelogram and squares.

Lesson 8.1 • Areas of Rectangles and Parallelograms

Name _____ Period _____ Date _____

In Exercises 1–4, find the area of the shaded region.

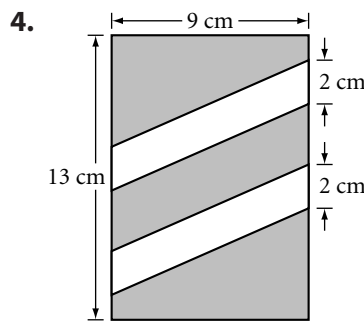
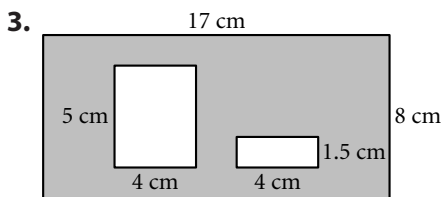
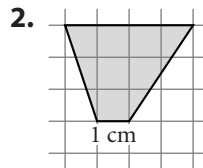
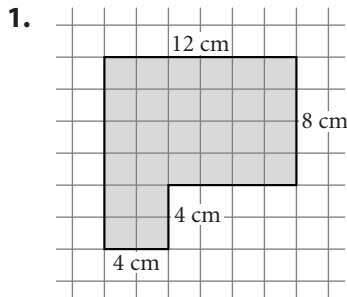

5. Rectangle $ABCD$ has area 2684 m^2 and width 44 m . Find its length.

6. Draw a parallelogram with area 85 cm^2 and an angle with measure 40° .
Is your parallelogram unique? If not, draw a different one.

7. Find the area of $PQRS$.

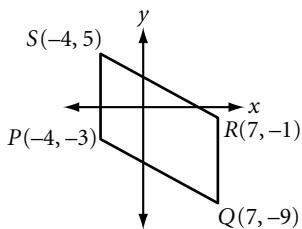

8. Find the area of $ABCDEF$.

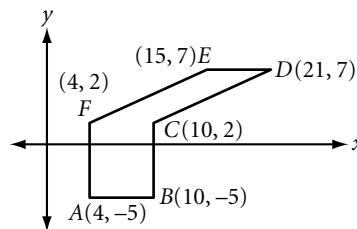

9. Dana buys a piece of carpet that measures 20 square yards. Will she be able to completely cover a rectangular floor that measures 12 ft 6 in. by 16 ft 6 in.? Explain why or why not.

Lesson 8.2 • Areas of Triangles, Trapezoids, and Kites

Name _____ Period _____ Date _____

In Exercises 1–4, solve for the unknown measures.

1. Area = 64 ft^2 , $h =$ _____.

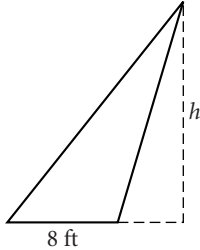

2. Area = _____.

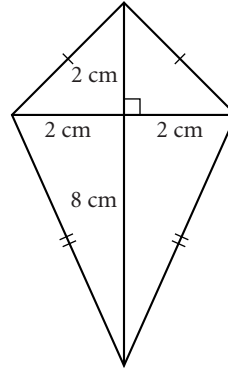

3. Area = 126 in^2
 $b =$ _____.

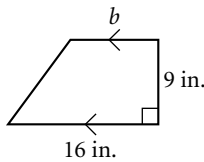

4. $AB = 6 \text{ cm}$, $AC = 8 \text{ cm}$, and $BC = 10 \text{ cm}$.
Find AD .

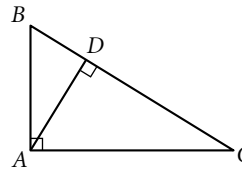

5. Find the area of the shaded region.

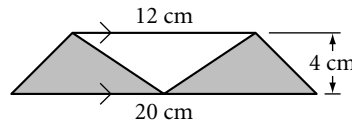

6. \overline{TP} is tangent to circles M and N . $TP = 16 \text{ cm}$. The radius of N is 7 cm and the radius of M is 4 cm . Find the area of $NMPT$.

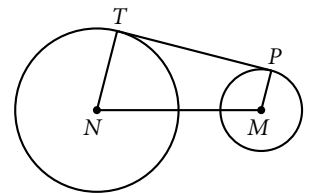

7. Find the area of $\triangle TRI$.

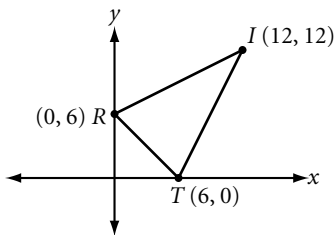

8. $ABCD$ is a parallelogram, $ABDE$ is a kite, $AD = 18 \text{ cm}$, and $BE = 10 \text{ cm}$. Find the area of $ABCDE$.

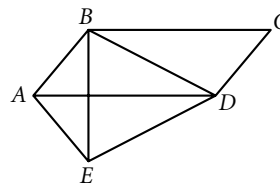

Lesson 8.3 • Area Problems

Name _____ Period _____ Date _____

1. A bundle of hardwood flooring contains $14\frac{1}{2}$ ft² and costs \$39.90.
 - a. How many square feet of flooring is needed to cover the kitchen and family room? Exclude the fireplace, hearth, and tiled area.
 - b. You should buy 5% extra flooring to account for waste. How many bundles of flooring should you buy? What will be the cost?

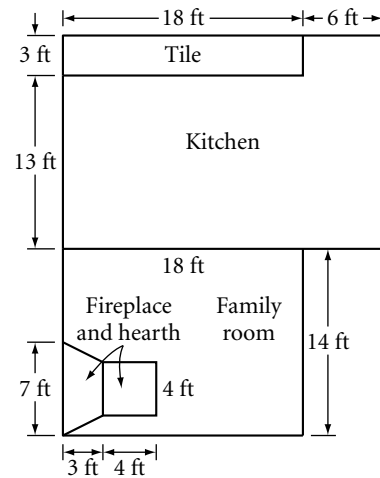

2. Bert's Bigtime Bakery has baked the world's largest chocolate cake. It is a rectangular sheet cake that is 600 cm by 400 cm by 180 cm high. Bert wants to apply frosting to the four sides and the top. How many liters of frosting does he need if 1 liter of frosting covers about 1200 cm²?

3. For a World Peace Day celebration the students at Cabot Junior/Senior High School are making a 6 m-by-8 m flag. Each of the six grades will create a motif to honor the people of the six inhabited continents. Sketch three possible ways to divide the flag: one into six congruent triangles; one into six triangles with equal area but none congruent; and one into six congruent trapezoids. Give measurements or markings on your sketches so each class knows it has equal area.

4. Kit and Kat are building a kite for the big kite festival. Kit has already cut his sticks for the diagonals. He wants to position *P* so that he will have maximum kite area. He asks Kat for advice. What should Kat tell him?

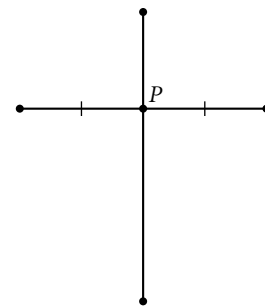

Lesson 8.4 • Areas of Regular Polygons

Name _____ Period _____ Date _____

In Exercises 1–3, the polygons are regular.

1. $s = 12$ cm
 $a \approx 14.5$ cm
 $A \approx$ _____

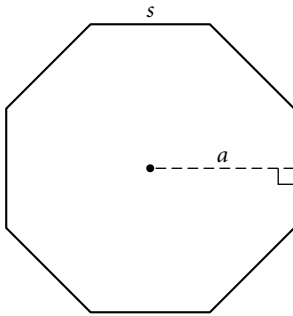

2. $s = 4.2$ cm
 $A \approx 197$ cm²
 $a \approx$ _____

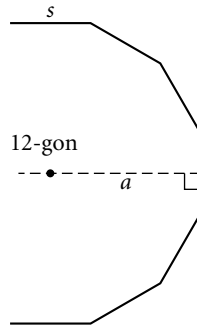

3. $a = 6$ cm
 $A \approx 130.8$ cm²
 $p \approx$ _____

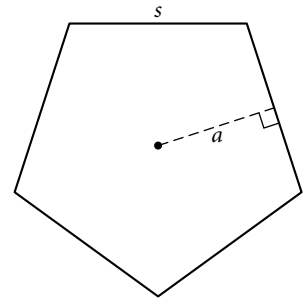

4. In a regular n -gon, $s = 4.8$ cm, $a \approx 7.4$ cm, and $A \approx 177.6$ cm². Find n .

5. Draw a regular pentagon so that it has perimeter 20 cm. Use the Regular Polygon Area Conjecture and a centimeter ruler to find its approximate area.

6. Use a compass and straightedge to construct a regular octagon and its apothem. Use a centimeter ruler to measure its side length and apothem, and use the Regular Polygon Area Conjecture to find its approximate area.

7. Find the area of the shaded region between the square and the regular octagon. $s \approx 5$ cm. $r = 3$ cm.

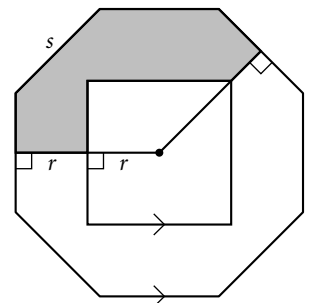

Lesson 8.5 • Areas of Circles

Name _____ Period _____ Date _____

In Exercises 1–4, write your answers in terms of π .

- 1. If $r = 9$ cm, $A =$ _____.
- 2. If $d = 6.4$ cm, $A =$ _____.
- 3. If $A = 529\pi$ cm², $r =$ _____.
- 4. If $C = 36\pi$ cm, $A =$ _____.

In Exercises 5–8, round your answers to the nearest 0.01 unit.

- 5. If $r = 7.8$ cm, $A \approx$ _____.
- 6. If $A = 136.46$, $C \approx$ _____.
- 7. If $d = 3.12$, $A \approx$ _____.
- 8. If $C = 7.85$, $A \approx$ _____.

For Exercises 9 and 10, refer to the figure of a circle inscribed in an equilateral triangle. Round your answers to the nearest 0.1 unit.

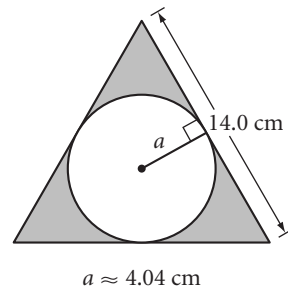

- 9. Find the area of the inscribed circle.
- 10. Find the area of the shaded region.

In Exercises 11 and 12, find the area of the shaded region. Write your answers in terms of π .

- 11. $ABCD$ is a square.

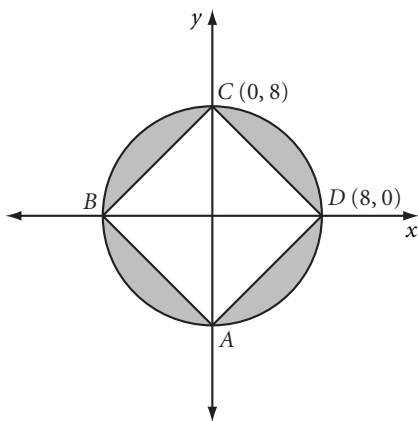

- 12. The three circles are tangent.

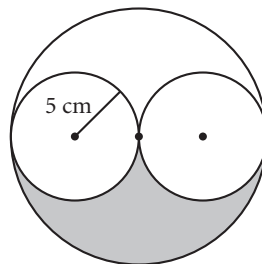

Lesson 8.6 • Any Way You Slice It

Name _____ Period _____ Date _____

In Exercises 1–6, find the area of the shaded region. Write your answers in terms of π and rounded to the nearest 0.01 cm^2 .

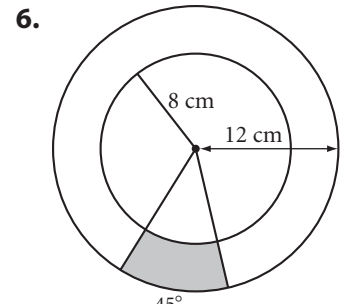
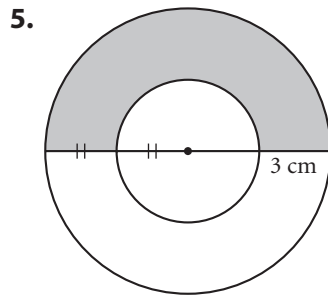
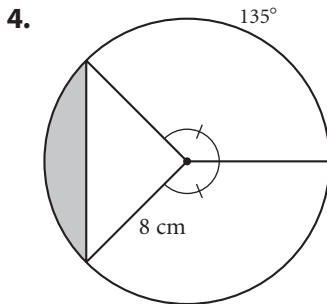
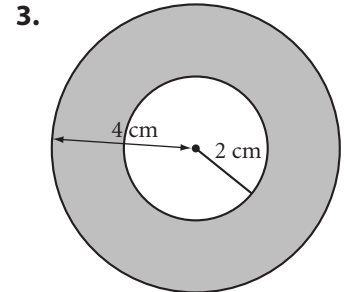
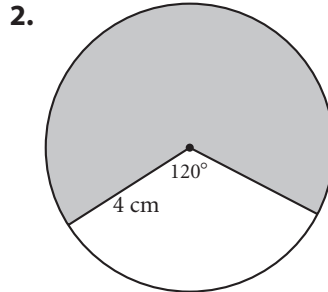
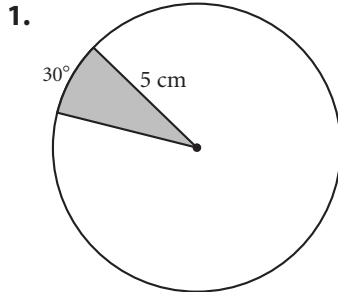

7. Shaded area is $40\pi \text{ cm}^2$.
Find r .

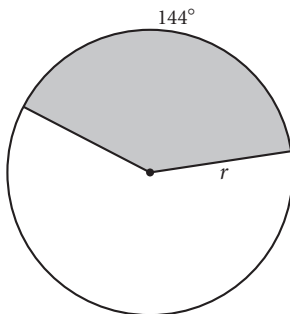

8. Shaded area is $54\pi \text{ cm}^2$.
Find x .

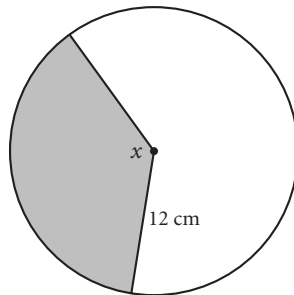

9. Shaded area is $51\pi \text{ cm}^2$.
The diameter of the larger circle is 20 cm. Find r .

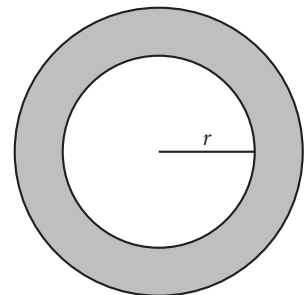

Lesson 8.7 • Surface Area

Name _____ Period _____ Date _____

In Exercises 1–8, find the surface area of each solid. All quadrilaterals are rectangles, and all measurements are in centimeters. Round your answers to the nearest 0.1 cm².

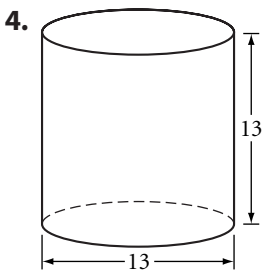
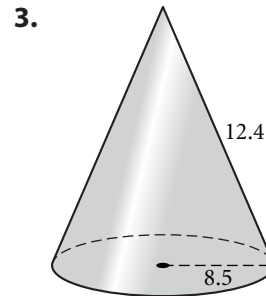
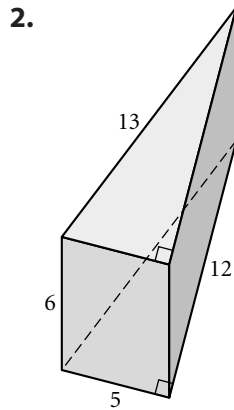
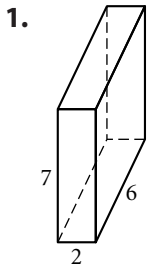

5. Base is a regular hexagon.
 $s = 6$, $a \approx 5.2$, and $l = 9$.

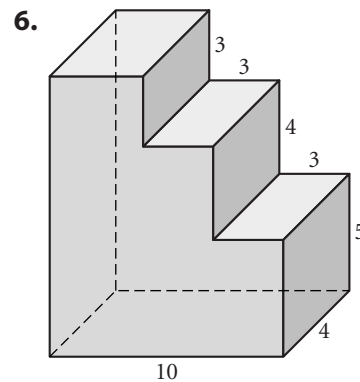
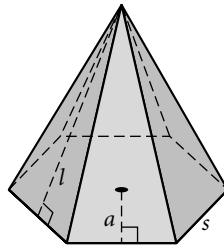

7. Both bases are squares.

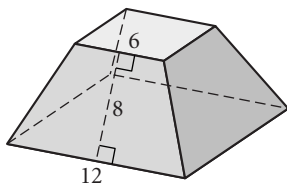

8. A square hole in a round peg

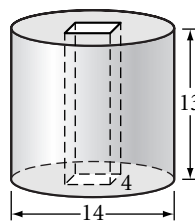

9. Ilsa is building a museum display case. The sides and bottom will be plywood and the top will be glass. Plywood comes in 4 ft-by-8 ft sheets. How many sheets of plywood will she need to buy? Explain. Sketch a cutting pattern that will leave her with the largest single piece possible.

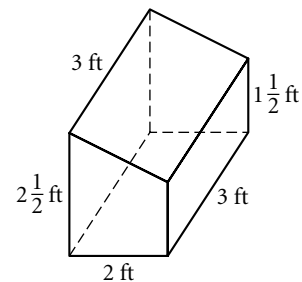

Lesson 9.1 • The Theorem of Pythagoras

Name _____ Period _____ Date _____

Give all answers rounded to the nearest 0.1 unit.

1. $a =$ _____

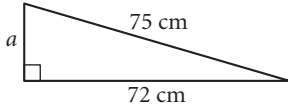

2. $p \approx$ _____

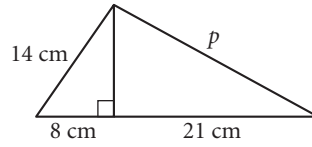

3. $x =$ _____

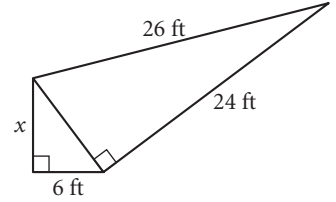

4. Area = 39 in^2

$h \approx$ _____

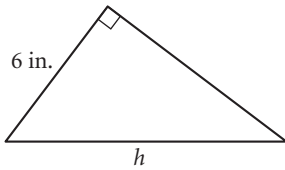

5. Find the area.

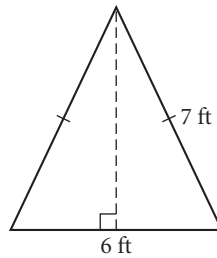

6. Find the coordinates of C and the radius of circle A .

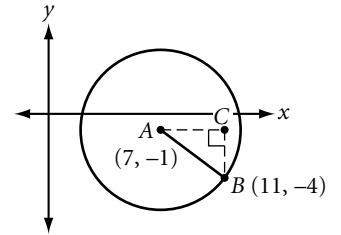

7. Find the area.

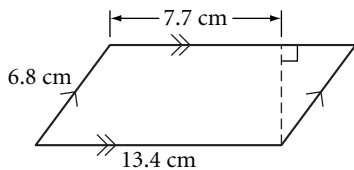

8. $RS = 3\text{ cm}$. Find RV .

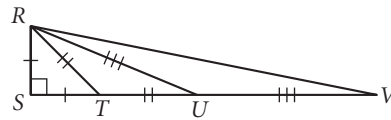

9. Base area = $16\pi\text{ cm}^2$ and slant height = 3 cm . What's wrong with this picture?

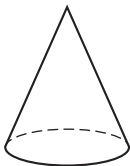

10. Given $\triangle PQR$, with $m\angle P = 90^\circ$, $PQ = 20\text{ in.}$, and $PR = 15\text{ in.}$, find the area of $\triangle PQR$, the length of the hypotenuse, and the altitude to the hypotenuse.

Lesson 9.2 • The Converse of the Pythagorean Theorem

Name _____ Period _____ Date _____

All measurements are in centimeters. Give answers rounded to the nearest 0.01 cm.

In Exercises 1–4, determine whether a triangle with the given side lengths is a right triangle.

1. 76, 120, 98 2. 221, 204, 85 3. 5.0, 1.4, 4.8 4. 80, 82, 18

5. Find the area of $\triangle ABC$.

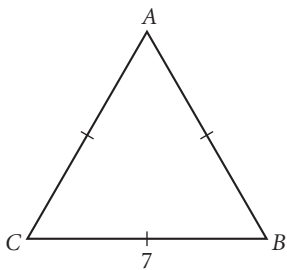

6. What's wrong with this picture?

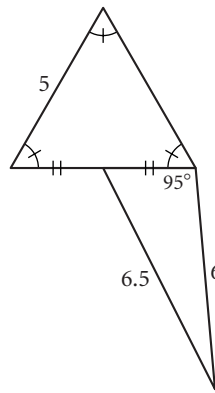

7. Find x . Explain your method.

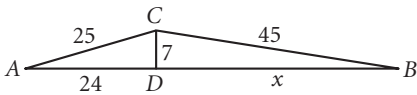

8. Find the area of $ABCD$.

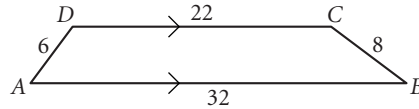

In Exercises 9–11, determine whether $ABCD$ is a rectangle and justify your answer. If not enough information is given, write “cannot be determined.”

9. $AB = 3$, $BC = 4$, and $AC = 6$.

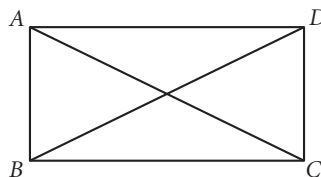

10. $AB = 3$, $BC = 4$, $DA = 4$, and $AC = 5$.

11. $AB = 3$, $BC = 4$, $CD = 3$, $DA = 4$, and $AC = BD$.

Lesson 9.3 • Two Special Right Triangles

Name _____ Period _____ Date _____

Give your answers in exact form unless otherwise indicated.
All measurements are in centimeters.

In Exercises 1–3, find the unknown lengths.

1. $a =$ _____

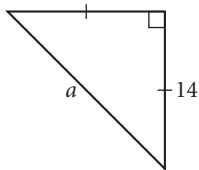

2. $a =$ _____, $b =$ _____

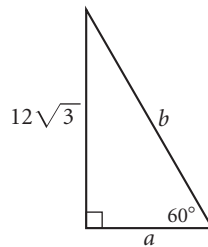

3. $a =$ _____, $b =$ _____

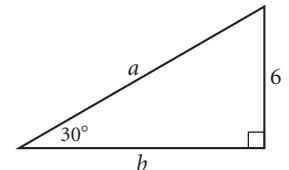

4. Find the area of rectangle $ABCD$.

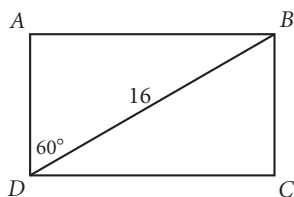

5. Find the perimeter and area of $KLMN$.

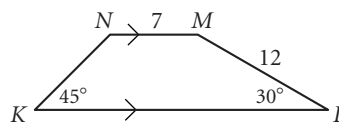

6. $AC =$ _____, $AB =$ _____,
and area $\triangle ABC =$ _____.

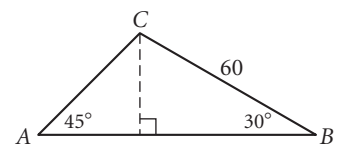

7. Find the area of an isosceles trapezoid if the bases have lengths 12 cm and 18 cm and the base angles have measure 60° .

In Exercises 8 and 9, find the coordinates of C .

8.

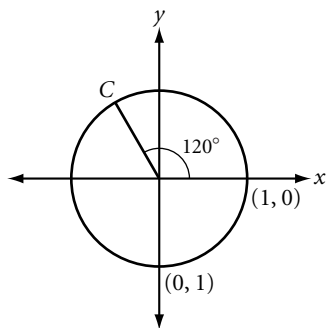

9.

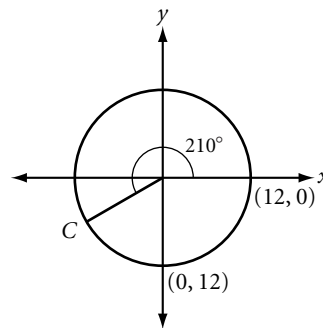

10. Sketch and label a figure to demonstrate that $\sqrt{18}$ is equivalent to $3\sqrt{2}$.

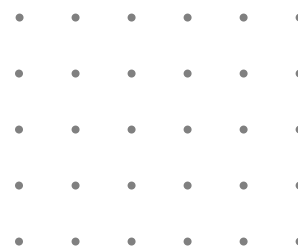

Lesson 9.4 • Story Problems

Name _____ Period _____ Date _____

1. A 20 ft ladder reaches a window 18 ft high. How far is the foot of the ladder from the base of the building? How far must the foot of the ladder be moved to lower the top of the ladder by 2 ft?
2. Robin and Dovey have four pet pigeons that they train to race. They release the birds at Robin's house and then drive to Dovey's to collect them. To drive from Robin's to Dovey's, because of one-way streets, they go 3.1 km north, turn right and go 1.7 km east, turn left and go 2.3 km north, turn right and go 0.9 km east, turn left and go 1.2 km north, turn left and go 4.1 km west, and finally turn left and go 0.4 km south. How far do the pigeons have to fly to go directly from Robin's house to Dovey's house?
3. Hans needs to paint the 18 in.-wide trim around the roof eaves and gable ends of his house with 2 coats of paint. A quart can of paint covers 175 ft^2 and costs \$9.75. A gallon can of paint costs \$27.95. How much paint should Hans buy? Explain.

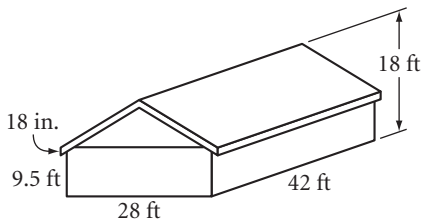

4. What are the dimensions of the largest 30° - 60° - 90° triangle that will fit inside a 45° - 45° - 90° triangle with leg length 14 in.? Sketch your solution.

Lesson 9.5 • Distance in Coordinate Geometry

Name _____ Period _____ Date _____

In Exercises 1–3, find the distance between each pair of points.

1. $(-5, -5), (1, 3)$ 2. $(-11, -5), (5, 7)$ 3. $(8, -2), (-7, 6)$

In Exercises 4 and 5, use the distance formula and the slope of segments to identify the type of quadrilateral. Explain your reasoning.

4. $A(-2, 1), B(3, -2), C(8, 1), D(3, 4)$ 5. $T(-3, -3), U(4, 4), V(0, 6), W(-5, 1)$

For Exercises 6 and 7, use $\triangle ABC$ with coordinates $A(4, 14)$, $B(10, 6)$, and $C(16, 14)$.

6. Determine whether $\triangle ABC$ is scalene, isosceles, or equilateral. Find the perimeter of the triangle.
7. Find the midpoints M and N of \overline{AB} and \overline{AC} , respectively. Find the slopes and lengths of \overline{MN} and \overline{BC} . How do the slopes compare? How do the lengths compare?

8. Find the equation of the circle with center $(-1, 5)$ and radius 2.

9. Find the center and radius of the circle whose equation is $x^2 + (y + 2)^2 = 25$.

10. P is the center of the circle. What's wrong with this picture?

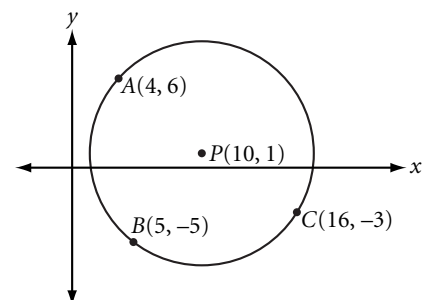

Lesson 9.6 • Circles and the Pythagorean Theorem

Name _____ Period _____ Date _____

In Exercises 1 and 2, find the area of the shaded region in each figure. All measurements are in centimeters. Write your answers in terms of π and rounded to the nearest 0.1 cm^2 .

1. $AO = 5$. $AC = 8$.

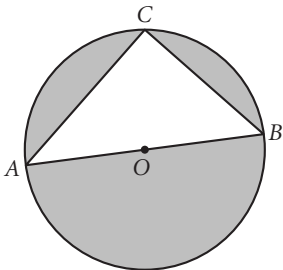

2. Tangent \overrightarrow{PT} , $QM = 12$, $m\angle P = 30^\circ$

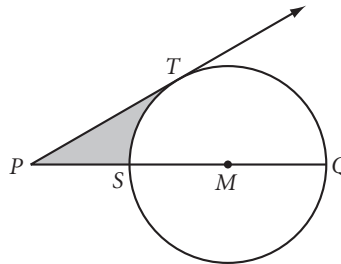

3. $AP = 63$ cm. Radius of circle $O = 37$ cm.
How far is A from the circumference of the circle?

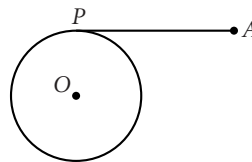

4. Two perpendicular chords with lengths 12.2 cm and 8.8 cm have a common endpoint. What is the area of the circle?

5. $ABCD$ is inscribed in a circle. \overline{AC} is a diameter. If $AB = 9.6$ cm, $BC = 5.7$ cm, and $CD = 3.1$ cm, find AD .

6. Find ST .

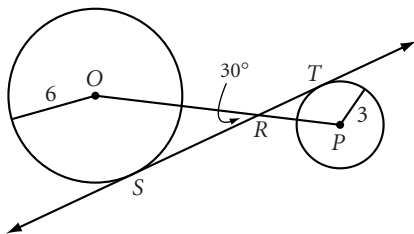

7. The coordinate of point M is $\left(\frac{-\sqrt{3}}{2}, \frac{1}{2}\right)$.
Find the measure of $\angle AOM$.

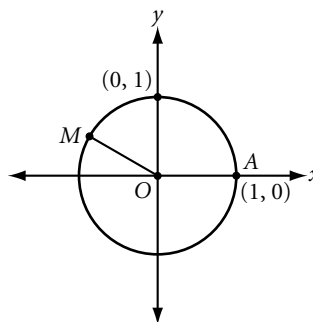

Lesson 10.1 • The Geometry of Solids

Name _____ Period _____ Date _____

For Exercises 1–14, refer to the figures below.

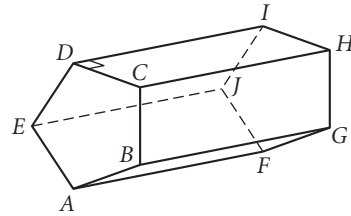
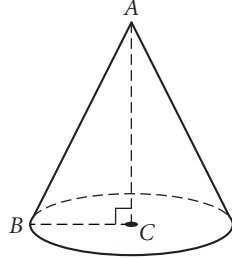
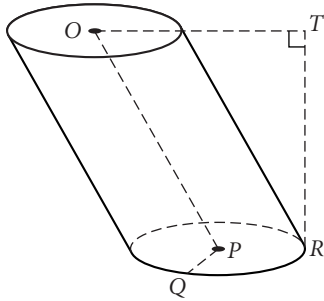

- The cylinder is (oblique, right).
- \overline{OP} is _____ of the cylinder.
- \overline{TR} is _____ of the cylinder.
- Circles O and P are _____ of the cylinder.
- \overline{PQ} is _____ of the cylinder.
- The cone is (oblique, right).
- Name the base of the cone.
- Name the vertex of the cone.
- Name the altitude of the cone.
- Name a radius of the cone.
- Name the type of prism.
- Name the bases of the prism.
- Name all lateral edges of the prism.
- Name an altitude of the prism.

In Exercises 15–17, tell whether each statement is true or false. If the statement is false, give a counterexample or explain why it is false.

- The axis of a cylinder is perpendicular to the base.
- A rectangular prism has four faces.
- The bases of a trapezoidal prism are trapezoids.

For Exercises 18 and 19, draw and label each solid. Use dashed lines to show the hidden edges.

- A right triangular prism with height equal to the hypotenuse
- An oblique trapezoidal pyramid

Lesson 10.2 • Volume of Prisms and Cylinders

Name _____ Period _____ Date _____

In Exercises 1–3, find the volume of each prism or cylinder. All measurements are in centimeters. Round your answers to the nearest 0.01.

1. Right triangular prism

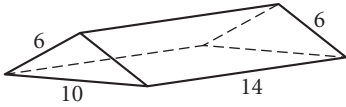

2. Right trapezoidal prism

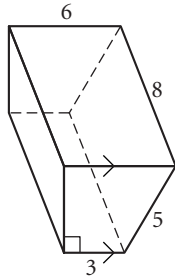

3. Regular hexagonal prism

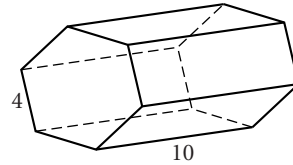

In Exercises 4–6, use algebra to express the volume of each solid.

4. Right rectangular prism

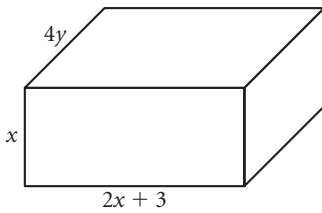

5. Right cylinder;
base circumference = $p\pi$

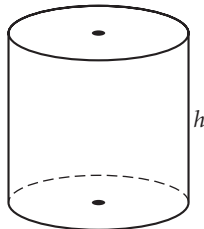

6. Right rectangular prism
and half of a cylinder

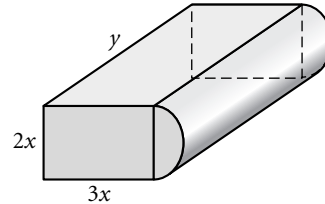

7. You need to build a set of solid cement steps for the entrance to your new house. How many cubic feet of cement do you need?

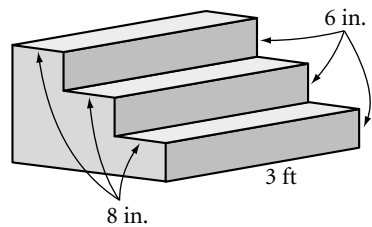

Lesson 10.3 • Volume of Pyramids and Cones

Name _____ Period _____ Date _____

In Exercises 1–3, find the volume of each solid. All measurements are in centimeters. Round your answers to two decimal places.

1. Rectangular pyramid; $OP = 6$ 2. Right hexagonal pyramid 3. Half of a right cone

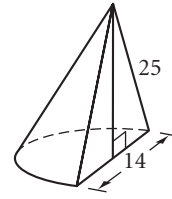
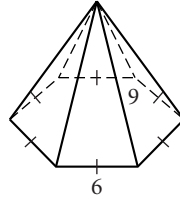
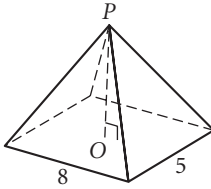

In Exercises 4–6, use algebra to express the volume of each solid.

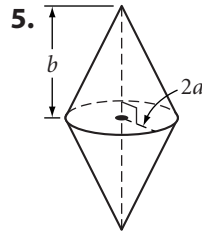
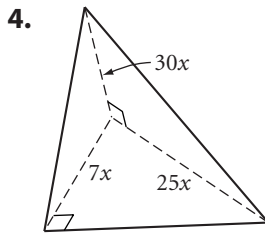

6. The solid generated by spinning $\triangle ABC$ about the axis

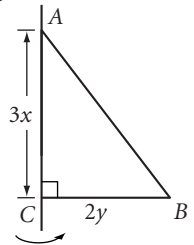

In Exercises 7–9, find the volume of each figure and tell which volume is larger.

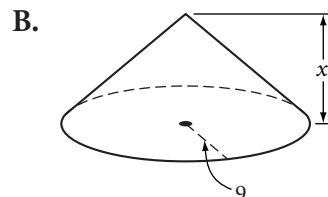
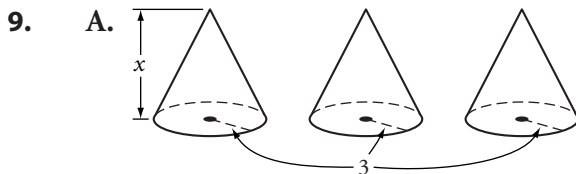
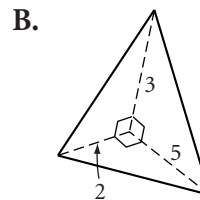
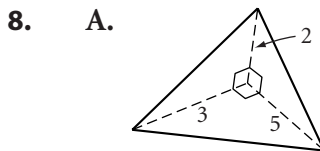
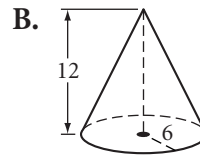
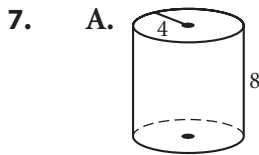

Lesson 10.4 • Volume Problems

Name _____ Period _____ Date _____

1. A cone has volume 320 cm^3 and height 16 cm. Find the radius of the base. Round your answer to the nearest 0.1 cm.
2. How many cubic inches are there in one cubic foot? Use your answer to help you with Exercises 3 and 4.
3. Jerry is packing cylindrical cans with diameter 6 in. and height 10 in. tightly into a box that measures 3 ft by 2 ft by 1 ft. All rows must contain the same number of cans. The cans can touch each other. He then fills all the empty space in the box with packing foam. How many cans can Jerry pack in one box? Find the volume of packing foam he uses. What percentage of the box's volume is filled by the foam?
4. A king-size waterbed mattress measures 72 in. by 84 in. by 9 in. Water weighs 62.4 pounds per cubic foot. An empty mattress weighs 35 pounds. How much does a full mattress weigh?

5. Square pyramid $ABCDE$, shown at right, is cut out of a cube with base $ABCD$ and shared edge \overline{DE} . $AB = 2 \text{ cm}$. Find the volume and surface area of the pyramid.

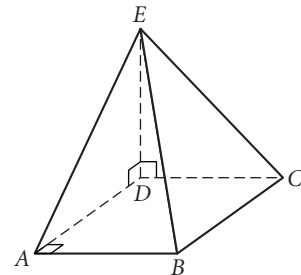

6. In Dingwall the town engineers have contracted for a new water storage tank. The tank is cylindrical with a base 25 ft in diameter and a height of 30 ft. One cubic foot holds about 7.5 gallons of water. About how many gallons will the new storage tank hold?

7. The North County Sand and Gravel Company stockpiles sand to use on the icy roads in the northern rural counties of the state. Sand is brought in by tandem trailers that carry 12 m^3 each. The engineers know that when the pile of sand, which is in the shape of a cone, is 17 m across and 9 m high they will have enough for a normal winter. How many truckloads are needed to build the pile?

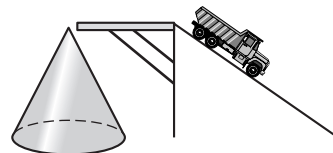

Lesson 10.5 • Displacement and Density

Name _____ Period _____ Date _____

1. A stone is placed in a 5 cm-diameter graduated cylinder, causing the water level in the cylinder to rise 2.7 cm. What is the volume of the stone?
2. A 141 g steel marble is submerged in a rectangular prism with base 5 cm by 6 cm. The water rises 0.6 cm. What is the density of the steel?
3. A solid wood toy boat with a mass of 325 g raises the water level of a 50 cm-by-40 cm aquarium 0.3 cm. What is the density of the wood?
4. For Awards Night at Baddeck High School, the math club is designing small solid silver pyramids. The base of the pyramids will be a 2 in.-by-2 in. square. The pyramids should not weigh more than $2\frac{1}{2}$ pounds. One cubic foot of silver weighs 655 pounds. What is the maximum height of the pyramids?
5. While he hikes in the Gold Country of northern California, Sid dreams about the adventurers that walked the same trails years ago. He suddenly kicks a small bright yellowish nugget. Could it be gold? Sid quickly makes a balance scale using his walking stick and finds that the nugget has the same mass as the uneaten half of his 330 g nutrition bar. He then drops the stone into his water bottle, which has a 2.5 cm radius, and notes that the water level goes up 0.9 cm. Has Sid struck gold? Explain your reasoning. (Refer to the density chart in Lesson 10.5 in your book.)

Lesson 10.6 • Volume of a Sphere

Name _____ Period _____ Date _____

In Exercises 1–6, find the volume of each solid. All measurements are in centimeters. Write your answers in exact form and rounded to the nearest 0.1 cm^3 .

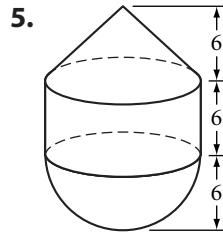
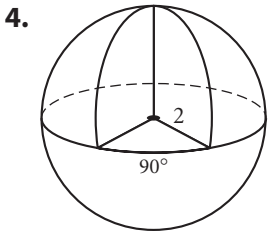
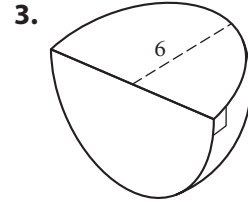
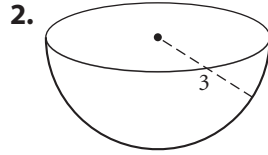
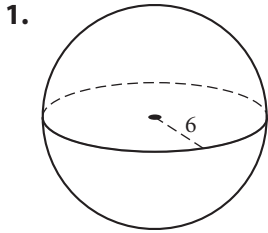

6. Cylinder with hemisphere taken out of the top

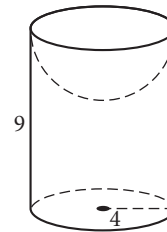

7. A sphere has volume $221\frac{5}{6}\pi \text{ cm}^3$. What is its diameter?
8. The area of the base of a hemisphere is $225\pi \text{ in}^2$. What is its volume?
9. Eight wooden spheres with radii 3 in. are packed snugly into a square box 12 in. on one side. The remaining space is filled with packing beads. What is the volume occupied by the packing beads? What percentage of the volume of the box is filled with beads?
10. The radius of Earth is about 6378 km, and the radius of Mercury is about 2440 km. About how many times greater is the volume of Earth than that of Mercury?

Lesson 10.7 • Surface Area of a Sphere

Name _____ Period _____ Date _____

In Exercises 1–4, find the volume and total surface area of each solid. All measurements are in centimeters. Round your answers to the nearest 0.1 cm.

1.

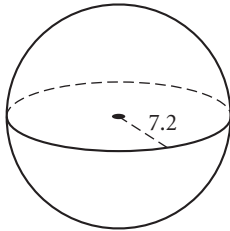

2.

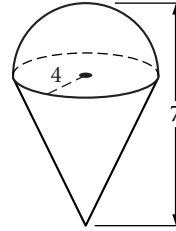

3.

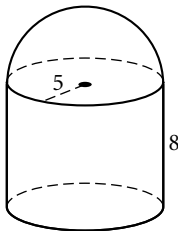

4.

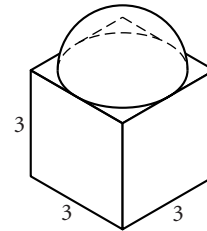

5. If the surface area of a sphere is 48.3 cm^2 , find its diameter.
6. If the volume of a sphere is 635 cm^3 , find its surface area.
7. Lobster fishers in Maine often use spherical buoys to mark their lobster traps. Every year the buoys must be repainted. An average buoy has a 12 in. diameter, and an average fisher has about 500 buoys. A quart of marine paint covers 175 ft^2 . How many quarts of paint does an average fisher need each year?

Lesson 11.1 • Similar Polygons

Name _____ Period _____ Date _____

All measurements are in centimeters.

1. HAPIE ~ NWYRS

AP = _____
 EI = _____
 SN = _____
 YR = _____

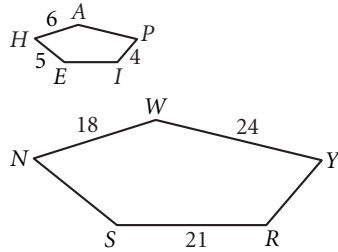

2. QUAD ~ SIML

SL = _____
 MI = _____
 $m\angle D =$ _____
 $m\angle U =$ _____
 $m\angle A =$ _____

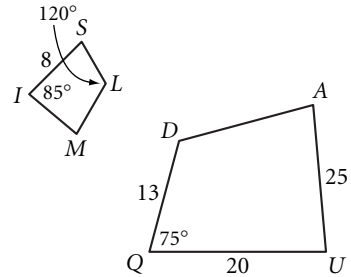

In Exercises 3–6, decide whether or not the figures are similar. Explain why or why not.

3. ABCD and EFGH

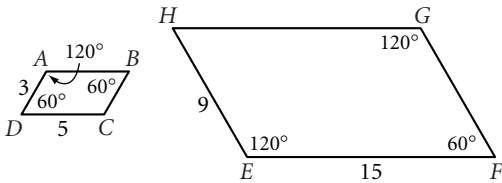

4. $\triangle ABC$ and $\triangle ADE$

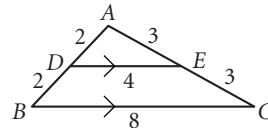

5. JKON and JKLM

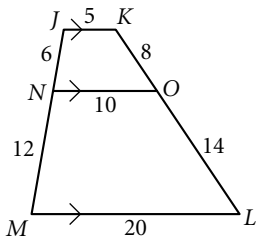

6. ABCD and AEEF

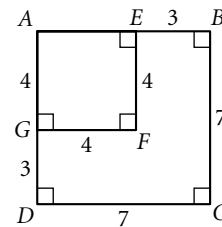

7. Draw the dilation of $ABCD$ by a scale factor of $\frac{1}{2}$. What is the ratio of the perimeter of the dilated quadrilateral to the perimeter of the original quadrilateral?

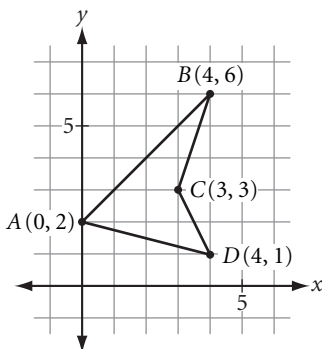

8. Draw the dilation of $\triangle DEF$ by a scale factor of 2. What is the ratio of the area of the dilated triangle to the area of the original triangle?

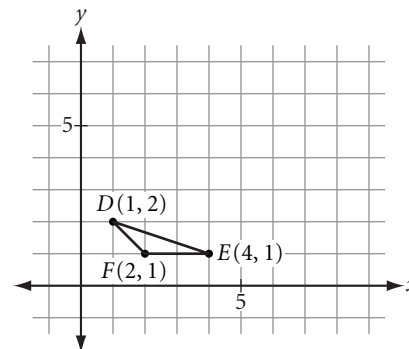

Lesson 11.2 • Similar Triangles

Name _____ Period _____ Date _____

All measurements are in centimeters.

1. $\triangle TAR \sim \triangle MAC$

$MC = \underline{\hspace{2cm}}$

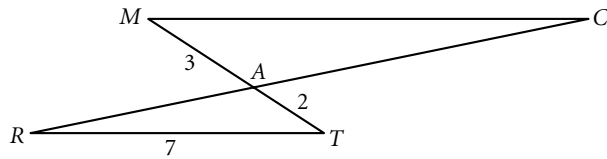

2. $\triangle XYZ \sim \triangle QRS$

$\angle Q \cong \underline{\hspace{2cm}}$

$QR = \underline{\hspace{2cm}}$

$QS = \underline{\hspace{2cm}}$

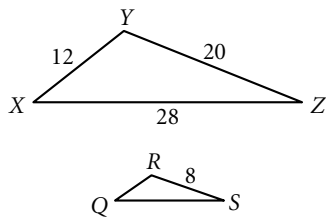

3. $\triangle ABC \sim \triangle EDC$

$\angle A \cong \underline{\hspace{2cm}}$

$CD = \underline{\hspace{2cm}}$

$AB = \underline{\hspace{2cm}}$

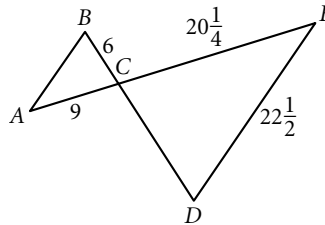

4. $\triangle TRS \sim \triangle TQP$

$TS = \underline{\hspace{2cm}}$

$QP = \underline{\hspace{2cm}}$

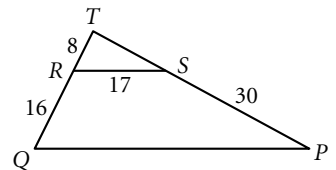

For Exercises 5 and 6, refer to the figure at right.

5. Explain why $\triangle CAT$ and $\triangle DAG$ are similar.

6. $CA = \underline{\hspace{2cm}}$

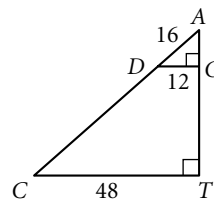

In Exercises 7–9, identify similar triangles and explain why they are similar.

7.

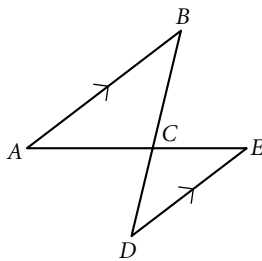

8.

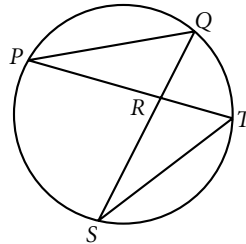

9.

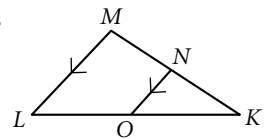

Lesson 11.3 • Indirect Measurement with Similar Triangles

Name _____ Period _____ Date _____

- At a certain time of day, a 6 ft man casts a 4 ft shadow. At the same time of day, how tall is a tree that casts an 18 ft shadow?
- Driving through the mountains, Dale has to go up and over a high mountain pass. The road has a constant incline for $7\frac{3}{4}$ miles to the top of the pass. Dale notices from a road sign that in the first mile he climbs 840 feet. How many feet does he climb in all?

- Sunrise Road is 42 miles long between the edge of Moon Lake and Lake Road and 15 miles long between Lake Road and Sunset Road. Lake Road is 29 miles long. Find the length of Moon Lake.

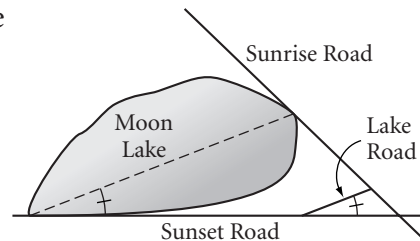

- Marta is standing 4 ft behind a fence 6 ft 6 in. tall. When she looks over the fence, she can just see the top edge of a building. She knows that the building is 32 ft 6 in. behind the fence. Her eyes are 5 ft from the ground. How tall is the building? Give your answer to the nearest half foot.

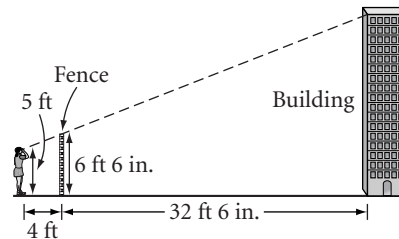

- You need to add 5 supports under the ramp, in addition to the 3.6 m one, so that they are all equally spaced. How long should each support be? (One is drawn in for you.)

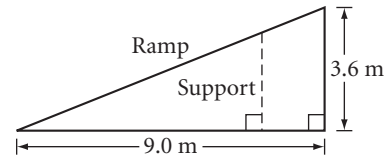

Lesson 11.4 • Corresponding Parts of Similar Triangles

Name _____ Period _____ Date _____

All measurements are in centimeters.

1. $\triangle ABC \sim \triangle PRQ$. M and N are midpoints. Find h and j .

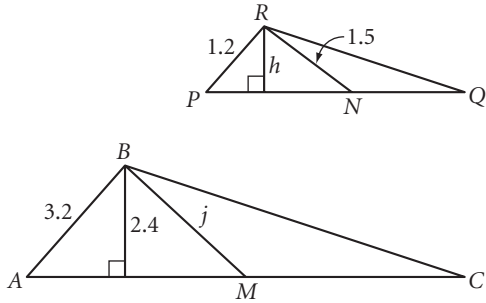

2. The triangles are similar. Find the length of each side of the smaller triangle to the nearest 0.01.

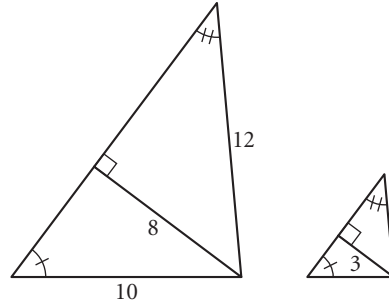

3. $\triangle ABC \sim \triangle WXY$

$WX =$ _____ $AD =$ _____
 $DB =$ _____ $YZ =$ _____
 $XZ =$ _____

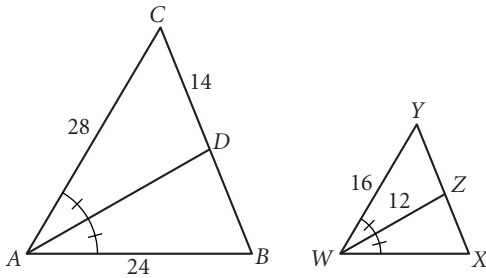

4. Find x and y .

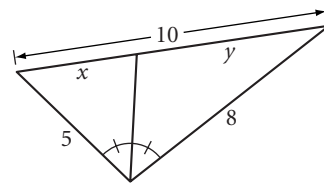

5. Find a , b , and c .

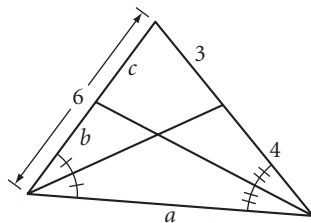

6. Find CB , CD , and AD .

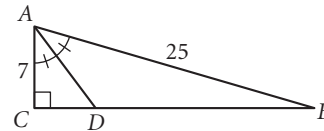

Lesson 11.5 • Proportions with Area

Name _____ Period _____ Date _____

All measurements are in centimeters unless otherwise indicated.

1. $\triangle ABC \sim \triangle DEF$. Area of $\triangle ABC = 15 \text{ cm}^2$. 2. $\frac{\text{Area of circle } O}{\text{Area of circle } P} = \frac{4}{9}$.

Area of $\triangle DEF = \underline{\hspace{2cm}}$

$a = \underline{\hspace{2cm}}$

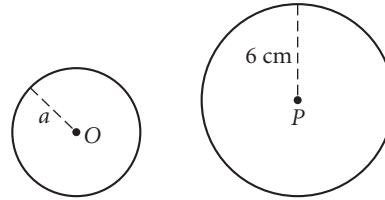
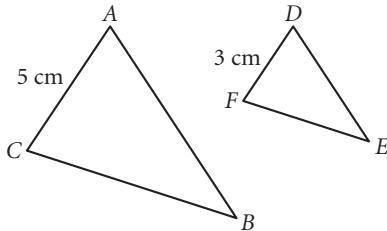

3. $\frac{\text{Area of square } SQUA}{\text{Area of square } LRGE} = \underline{\hspace{2cm}}$ 4. $\frac{\text{Area of circle } P}{\text{Area of circle } O} = \underline{\hspace{2cm}}$ 5. $RECT \sim ANGL$

$\frac{\text{Area of } RECT}{\text{Area of } ANGL} = \underline{\hspace{2cm}}$

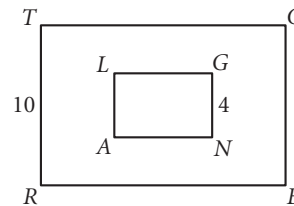
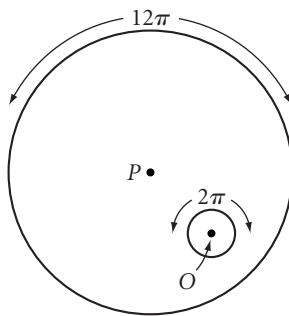
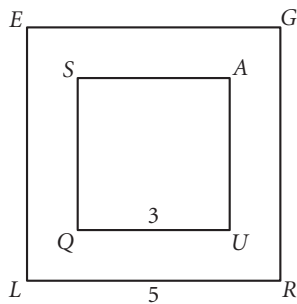

6. The ratio of the corresponding midsegments of two similar trapezoids is 4:5. What is the ratio of their areas?
7. The ratio of the areas of two similar pentagons is 4:9. What is the ratio of their corresponding sides?
8. If $ABCDE \sim FGHIJ$, $AC = 6 \text{ cm}$, $FH = 10 \text{ cm}$, and area of $ABCDE = 320 \text{ cm}^2$, then area of $FGHIJ = \underline{\hspace{2cm}}$.
9. Stefan is helping his mother retiling the kitchen floor. The tiles are 4-by-4-inch squares. The kitchen is square, and the area of the floor is 144 square feet. Assuming the tiles fit snugly (don't worry about grout), how many tiles will be needed to cover the floor?

Lesson 11.6 • Proportions with Volume

Name _____ Period _____ Date _____

All measurements are in centimeters unless otherwise indicated.

In Exercises 1 and 2, decide whether or not the two solids are similar.

1.

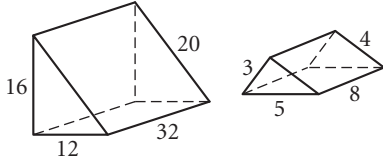

2.

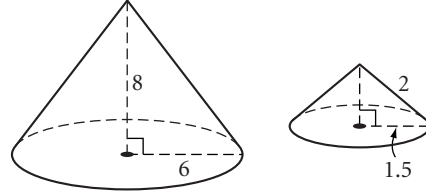

3. The triangular prisms are similar and the ratio of a to b is $\frac{5}{2}$.

Volume of large prism = 250 cm^3

Volume of smaller prism = _____

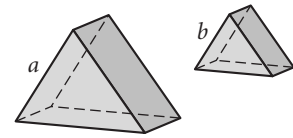

4. The right cylinders are similar and $r = 10 \text{ cm}$.

Volume of large cylinder = 64 cm^3

Volume of small cylinder = 8 cm^3

$R =$ _____

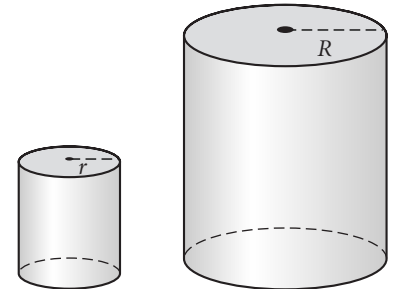

5. The corresponding heights of two similar cylinders is 2:5. What is the ratio of their volumes?

6. A rectangular prism aquarium holds 64 gallons of water. A similarly shaped aquarium holds 8 gallons of water. If a 1.5 ft^2 cover fits on the smaller tank, what is the area of a cover that will fit on the larger tank?

Lesson 11.7 • Proportional Segments Between Parallel Lines

Name _____ Period _____ Date _____

All measurements are in centimeters.

1. $x =$ _____

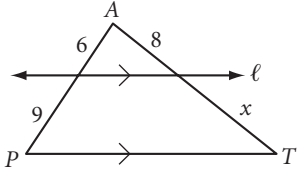

2. Is $\overline{XY} \parallel \overline{BC}$?

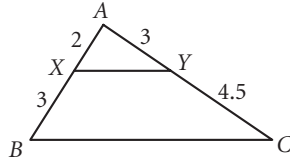

3. Is $\overline{XY} \parallel \overline{MK}$?

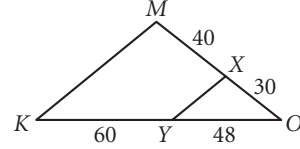

4. $NE =$ _____

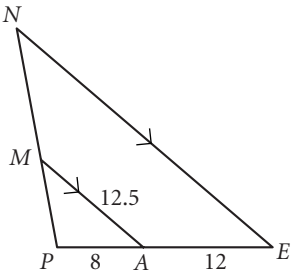

5. $PR =$ _____

$PQ =$ _____

$RI =$ _____

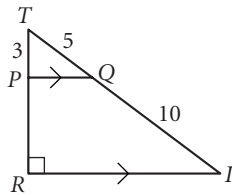

6. $a =$ _____

$b =$ _____

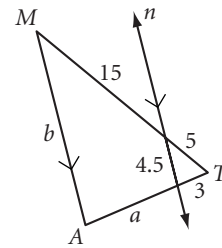

7. $RS =$ _____

$EB =$ _____

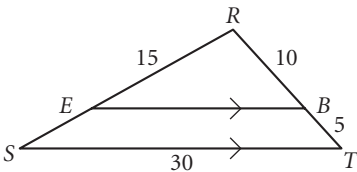

8. $x =$ _____

$y =$ _____

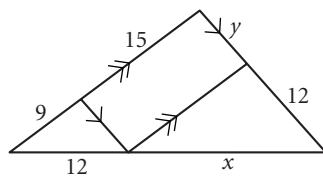

9. $p =$ _____

$q =$ _____

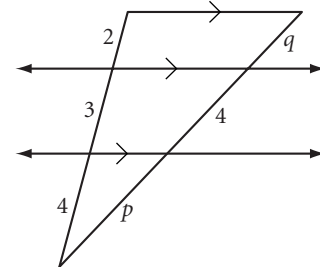

Lesson 12.1 • Trigonometric Ratios

Name _____ Period _____ Date _____

In Exercises 1–4, give each answer as a fraction in terms of p , q , and r .

1. $\sin P =$ _____

2. $\cos P =$ _____

3. $\tan P =$ _____

4. $\sin Q =$ _____

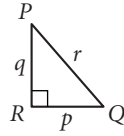

In Exercises 5–8, give each answer as a decimal accurate to the nearest 0.001.

5. $\sin T =$ _____

6. $\cos T =$ _____

7. $\tan T =$ _____

8. $\sin R =$ _____

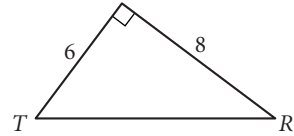

For Exercises 9–11, solve for x . Express each answer accurate to the nearest 0.01.

9. $\cos 64^\circ = \frac{x}{28}$

10. $\sin 24^\circ = \frac{12.1}{x}$

11. $\tan 51^\circ = \frac{x}{14.8}$

For Exercises 12–14, find the measure of each angle to the nearest degree.

12. $\sin A = 0.9455$

13. $\tan B = \frac{4}{3}$

14. $\cos C = 0.8660$

For Exercises 15–17, write a trigonometric equation you can use to solve for the unknown value. Then find the value to the nearest 0.1.

15. $w \approx$ _____

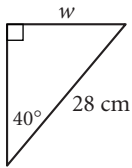

16. $x \approx$ _____

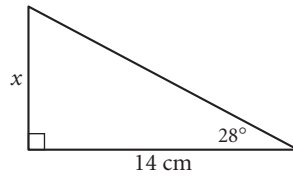

17. $y \approx$ _____

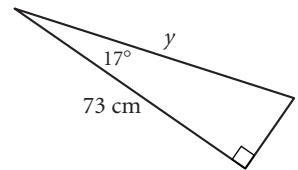

For Exercises 18–20, find the value of each unknown to the nearest degree.

18. $a \approx$ _____

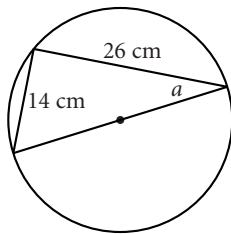

19. $t \approx$ _____

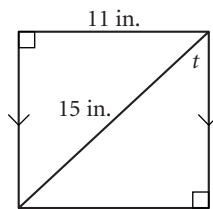

20. $z \approx$ _____

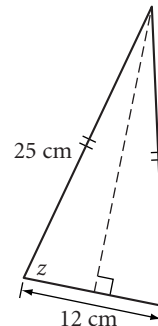

Lesson 12.2 • Problem Solving with Right Triangles

Name _____ Period _____ Date _____

For Exercises 1–3, find the area of each figure to the nearest square unit.

1. Area \approx _____

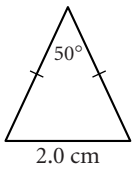

2. Area \approx _____

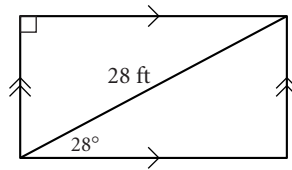

3. Area \approx _____

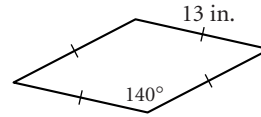

For Exercises 4–9, find each unknown to the nearest tenth of a unit.

4. Area = 88 cm²

$x \approx$ _____

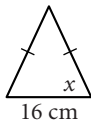

5. $y \approx$ _____

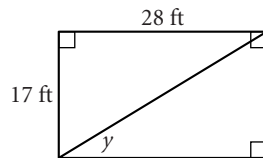

6. $a \approx$ _____

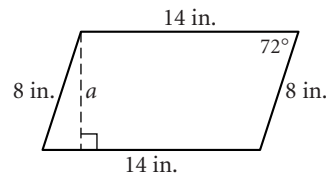

7. \overrightarrow{PS} and \overrightarrow{PT} are tangents.

Diameter \approx _____

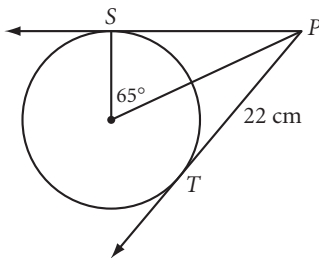

8. Right cone

$\theta \approx$ _____

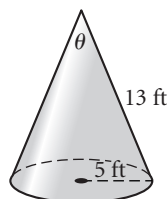

9. Right rectangular prism

$m\angle ABC = \beta \approx$ _____

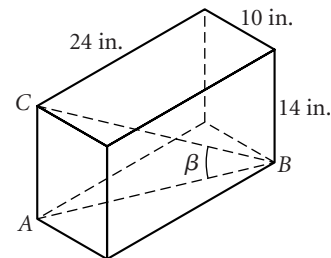

In Exercises 10–12, give each answer to the nearest tenth of a unit.

10. A ladder 7 m long stands on level ground and makes a 73° angle with the ground as it rests against a wall. How far from the wall is the base of the ladder?

11. To see the top of a building 1000 feet away, you look up 24° from the horizontal. What is the height of the building?

12. A guy wire is anchored 12 feet from the base of a pole. The wire makes a 58° angle with the ground. How long is the wire?

Lesson 12.3 • The Law of Sines

Name _____ Period _____ Date _____

In Exercises 1–3, find the area of each figure to the nearest square unit.

1. Area \approx _____

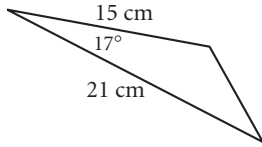

2. Area \approx _____

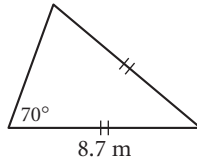

3. Area \approx _____

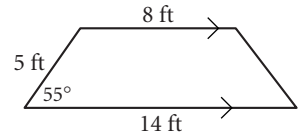

In Exercises 4–6, find each length to the nearest centimeter. All lengths are in centimeters.

4. $m \approx$ _____

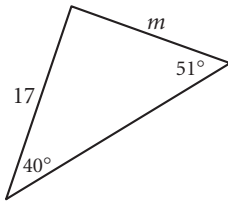

5. $p \approx$ _____

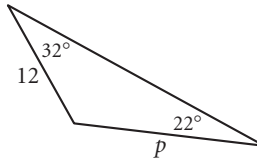

6. $q \approx$ _____

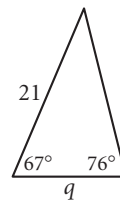

In Exercises 7–9, find the measure of each angle to the nearest degree.

7. $m\angle B \approx$ _____

$m\angle C \approx$ _____

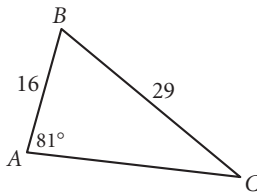

8. $m\angle P \approx$ _____

$m\angle Q \approx$ _____

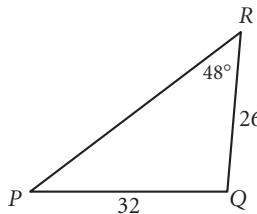

9. $m\angle K \approx$ _____

$m\angle M \approx$ _____

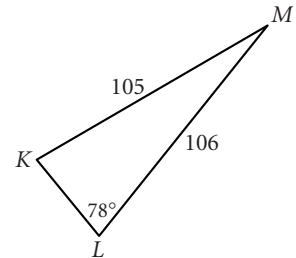

10. A large helium balloon is tethered to the ground by two taut lines. One line is 100 feet long and makes an 80° angle with the ground. The second line makes a 40° angle with the ground. How long is the second line, to the nearest foot? How far apart are the tethers?

Lesson 12.4 • The Law of Cosines

Name _____ Period _____ Date _____

In Exercises 1–3, find each length to the nearest centimeter. All lengths are in centimeters.

1. $t \approx$ _____

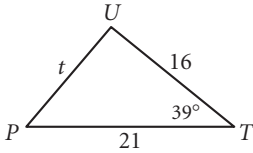

2. $b \approx$ _____

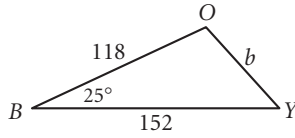

3. $w \approx$ _____

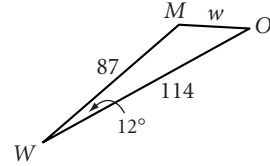

In Exercises 4–6, find each angle measure to the nearest degree.

4. $m\angle A \approx$ _____

$m\angle B \approx$ _____

$m\angle C \approx$ _____

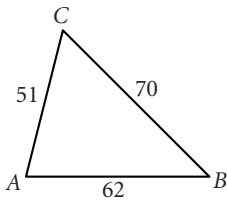

5. $m\angle A \approx$ _____

$m\angle P \approx$ _____

$m\angle S \approx$ _____

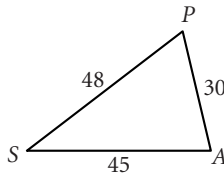

6. $m\angle S \approx$ _____

$m\angle U \approx$ _____

$m\angle V \approx$ _____

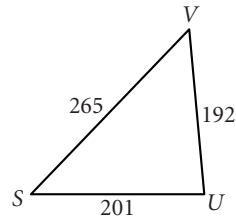

7. A circle with radius 12 in. has radii drawn to the endpoints of a 5 in. chord. What is the measure of the central angle?

8. A parallelogram has side lengths 22.5 cm and 47.8 cm. One angle measures 116° . What is the length of the shorter diagonal?

9. The diagonals of a parallelogram are 60 in. and 70 in. and intersect at an angle measuring 64° . Find the length of the shorter side of the parallelogram.

Lesson 12.5 • Problem Solving with Trigonometry

Name _____ Period _____ Date _____

1. While floating down a river with a 2.75 mi/h current, Alicia decides to swim directly toward the river bank. She can swim 0.75 mi/h in still water. What is the actual speed at which she moves toward the bank? At what angle will she approach the bank, measured with respect to the bank?

2. Find the measure of each angle to the nearest hundredth of a degree.

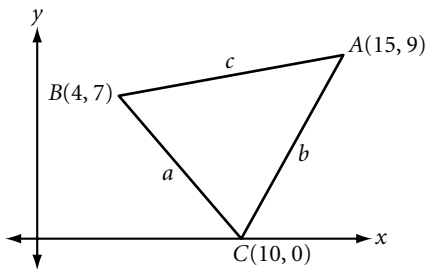

3. Two fire watchtowers 8.4 km apart spot a fire at the same time. Tower 1 reports the fire at a 36° angle measure from its line of sight to Tower 2. Tower 2 reports a 68° angle measure between the fire and Tower 1. How far is the fire from each tower?
4. Two airplanes leave O'Hare Airport in Chicago at the same time. One plane flies 280 mi/h at bearing 55° . The other plane flies 350 mi/h at bearing 128° . How far apart are the two planes after 2 hours 15 minutes?
5. Carla needs to fence her triangular plot of land. The angle between the two shorter sides measures 83° . The shortest side is 122 ft and the longest is 215 ft. How much fencing does Carla need? What is the area of her plot of land?

Lesson 13.1 • The Premises of Geometry

Name _____ Period _____ Date _____

1. Provide the missing property of equality or arithmetic as a reason for each step to solve the equation.

Solve for x : $5(x - 4) = 2x + 17$

Solution: $5(x - 4) = 2x + 17$ a. _____

$5x - 20 = 2x + 17$ b. _____

$3x - 20 = 17$ c. _____

$3x = 37$ d. _____

$x = \frac{37}{3}$ e. _____

In Exercises 2–4, identify each statement as true or false. If the statement is true, tell which definition, property, or postulate supports your answer. If the statement is false, give a counterexample.

2. If $AM = BM$, then M is the midpoint of \overline{AB} .
3. If P is on \overleftrightarrow{AB} and D is not, then $m\angle APD + m\angle BPD = 180^\circ$.
4. If $\overline{PQ} \cong \overline{ST}$ and $\overline{PQ} \cong \overline{KL}$, then $ST = KL$.

5. Complete the flowchart proof.

Given: $\overline{AB} \parallel \overline{CD}$, $\overline{AP} \parallel \overline{CQ}$, $\overline{PB} \cong \overline{QD}$

Show: $\overline{AB} \cong \overline{CD}$

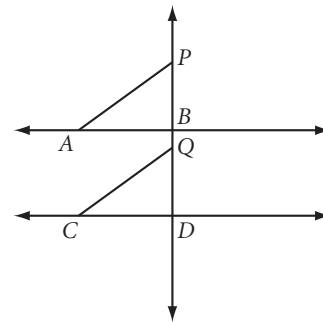

Flowchart Proof

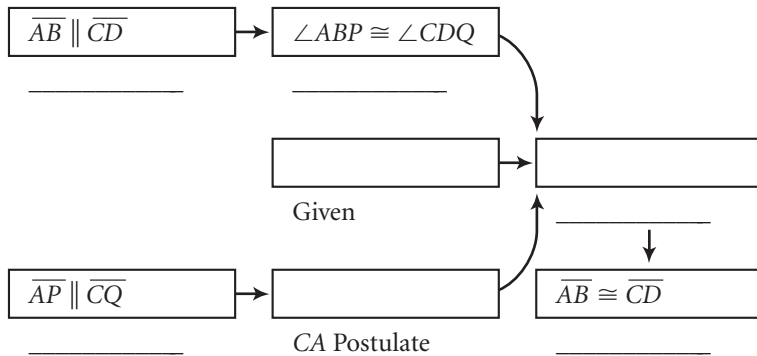

Lesson 13.2 • Planning a Geometry Proof

Name _____ Period _____ Date _____

For these exercises, you may use theorems added to your theorem list through the end of Lesson 13.2.

In Exercises 1–3, write a paragraph proof or a flowchart proof for each situation.

1. **Given:** $\overline{AB} \parallel \overline{CD}$, $\overline{AP} \parallel \overline{CQ}$

Show: $\angle PAB \cong \angle QCD$

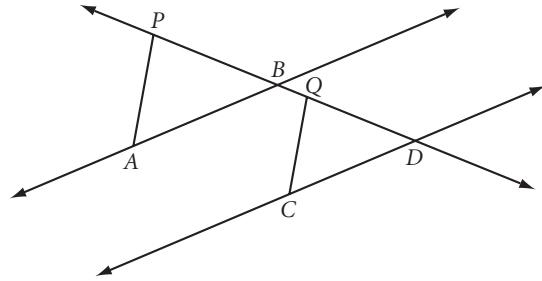

2. **Given:** $\overline{PQ} \parallel \overline{ST}$, $\angle QPR \cong \angle STU$

Show: $\overline{PR} \parallel \overline{UT}$

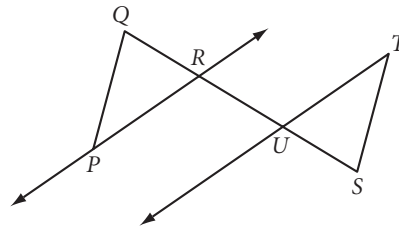

3. **Given:** Noncongruent, nonparallel segments AB , BC , and AC

Show: $x + y + z = 180^\circ$

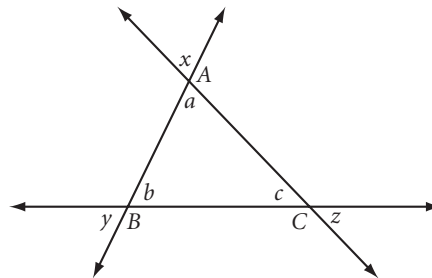

Lesson 13.3 • Triangle Proofs

Name _____ Period _____ Date _____

Write a proof for each situation. You may use theorems added to your theorem list through the end of Lesson 13.3.

1. **Given:** $\overline{XY} \cong \overline{ZY}$, $\overline{XZ} \perp \overline{WY}$

Show: $\triangle WXY \cong \triangle WZY$

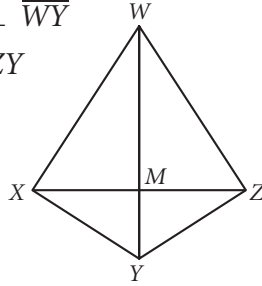

2. **Given:** $\overline{CD} \perp \overline{AC}$, $\overline{BD} \perp \overline{AB}$, $\overline{CD} \cong \overline{BD}$

Show: $\triangle ABD \cong \triangle ACD$

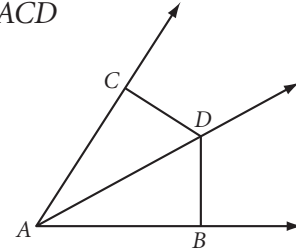

3. **Given:** $\overline{MN} \cong \overline{QM}$, $\overline{NO} \cong \overline{QO}$,
P is the midpoint of \overline{MO}

Show: $\angle QMN \cong \angle QON$

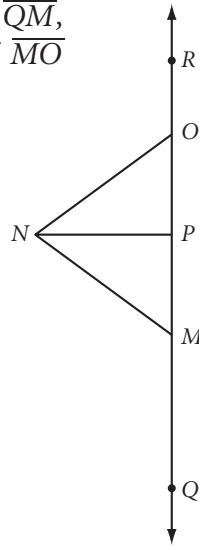

4. **Given:** $\overline{AB} \cong \overline{BC}$, $\angle ACB \cong \angle ECD$,
 $\overline{AB} \perp \overline{BD}$

Show: $\overline{BD} \perp \overline{CE}$

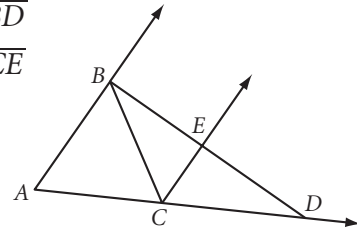

Lesson 13.4 • Quadrilateral Proofs

Name _____ Period _____ Date _____

In Exercises 1–6, write a proof of each conjecture on a separate piece of paper. You may use theorems added to your theorem list through the end of Lesson 13.4.

1. The diagonals of a parallelogram bisect each other. (Parallelogram Diagonals Theorem)
2. If the diagonals of a quadrilateral bisect each other, then the quadrilateral is a parallelogram. (Converse of the Parallelogram Diagonals Theorem)
3. The diagonals of a rhombus bisect each other and are perpendicular. (Rhombus Diagonals Theorem)
4. If the diagonals of a quadrilateral bisect each other and are perpendicular, then the quadrilateral is a rhombus. (Converse of the Rhombus Diagonals Theorem)
5. If the base angles on one base of a trapezoid are congruent, then the trapezoid is isosceles. (Converse of the Isosceles Trapezoid Theorem)
6. If the diagonals of a trapezoid are congruent, then the trapezoid is isosceles. (Converse of the Isosceles Trapezoid Diagonals Theorem)

In Exercises 7–9, decide if the statement is true or false. If it is true, prove it. If it is false, give a counterexample.

7. A quadrilateral with one pair of parallel sides and one pair of congruent angles is a parallelogram.
8. A quadrilateral with one pair of congruent opposite sides and one pair of parallel sides is a parallelogram.
9. A quadrilateral with one pair of parallel sides and one pair of congruent opposite angles is a parallelogram.

Lesson 13.5 • Indirect Proof

Name _____ Period _____ Date _____

1. Complete the indirect proof of the conjecture: In a triangle the side opposite the larger of two angles has a greater measure.

Given: $\triangle ABC$ with $m\angle A > m\angle B$

Show: $BC > AC$

Proof: Assume _____

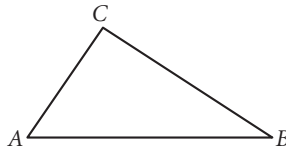

Case 1: $BC = AC$

If $BC = AC$, then $\triangle ABC$ is _____ by _____.

By _____, $\angle A \cong \angle B$, which contradicts _____.

So, $BC \neq AC$.

Case 2: $BC < AC$

If $BC < AC$, then it is possible to construct point D on \overline{CA} such that $\overline{CD} \cong \overline{CB}$, by the Segment Duplication Postulate. Construct \overline{DB} , by the Line Postulate. $\triangle DBC$ is _____. Complete the proof.

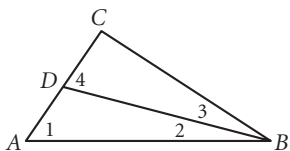

In Exercises 2–5, write an indirect proof of each conjecture.

2. **Given:** $\overline{AD} \cong \overline{AB}$, $\overline{DC} \cong \overline{BC}$

Show: $\angle DAC \cong \angle BAC$

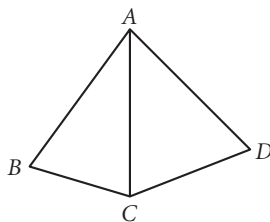

3. If two sides of a triangle are not congruent, then the angles opposite them are not congruent.

4. If two lines are parallel and a third line in the same plane intersects one of them, then it also intersects the other.

Lesson 13.6 • Circle Proofs

Name _____ Period _____ Date _____

Write a proof for each conjecture or situation. You may use theorems added to your theorem list through the end of Lesson 13.6.

1. If two chords in a circle are congruent, then their arcs are congruent.

2. **Given:** Regular pentagon $ABCDE$ inscribed in circle O , with diagonals \overline{AC} and \overline{AD}

Show: \overline{AC} and \overline{AD} trisect $\angle BAE$

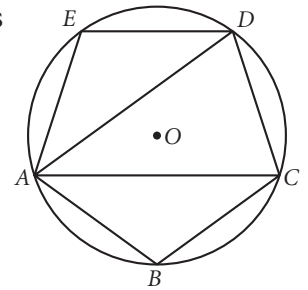

3. **Given:** Two circles externally tangent at R , common external tangent segment \overline{TS}

Show: $\angle TRS$ is a right angle

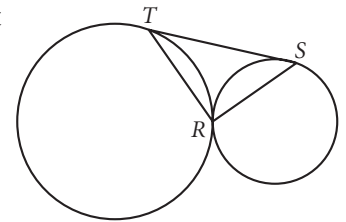

4. **Given:** Two circles internally tangent at T with chords \overline{TD} and \overline{TB} of the larger circle intersecting the smaller circle at C and A

Show: $\overline{AC} \parallel \overline{BD}$

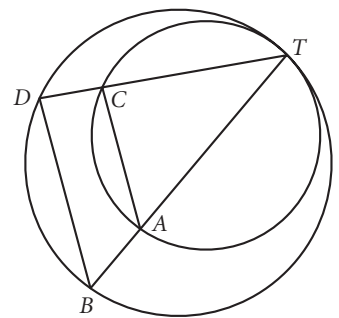

Lesson 13.7 • Similarity Proofs

Name _____ Period _____ Date _____

Write a proof for each situation. You may use theorems added to your theorem list through the end of Lesson 13.7.

1. **Given:** $\triangle ABC$ with $\angle A \cong \angle BCD$

Show: $BC^2 = AB \cdot BD$

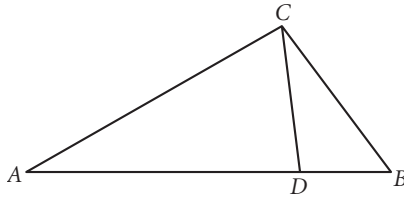

- The diagonals of a trapezoid divide each other into segments with lengths in the same ratio as the lengths of the bases.
- In a right triangle the product of the lengths of the two legs equals the product of the lengths of the hypotenuse and the altitude to the hypotenuse.
- If a quadrilateral has one pair of opposite right angles and one pair of opposite congruent sides, then the quadrilateral is a rectangle.

ANSWERS

LESSON 1.1 • Building Blocks of Geometry

1. S 2. 9 cm 3. \overline{SN} 4. endpoint
 5. \overline{NS} 6. \overline{PQ} 7. \overline{SP}
 8. $\overline{KN} \cong \overline{KL}$, $\overline{NM} \cong \overline{LM}$, $\overline{NO} \cong \overline{LO}$
 9. $E(-14, 15)$

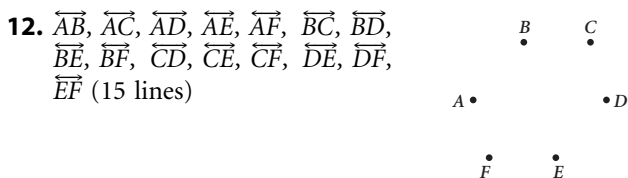
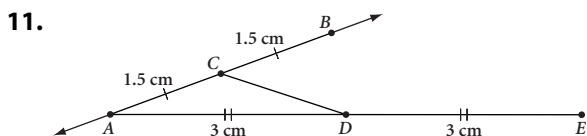
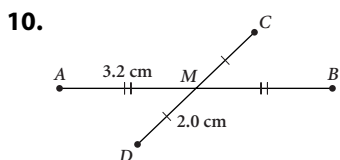

13. Possible coplanar set: $\{C, D, H, G\}$; 12 different sets

LESSON 1.2 • Poolroom Math

1. vertex 2. bisector 3. side
 4. 126° 5. $\angle DAE$ 6. 133°
 7. 47° 8. 63° 9. 70°

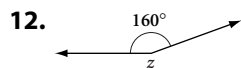
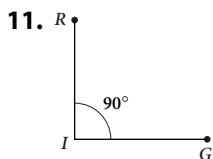
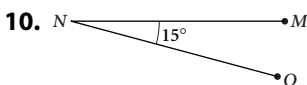

13. 90° 14. 120° 15. 75°

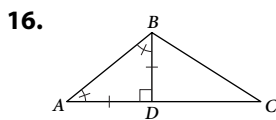

17.

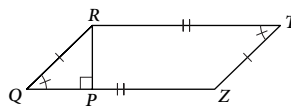

LESSON 1.3 • What's a Widget?

1. d 2. c 3. e 4. i
 5. f 6. b 7. h 8. a

9. g

10. They have the same measure, 13° . Because $m\angle Q = 77^\circ$, its complement has measure 13° . So $m\angle R = 13^\circ$, which is the same as $m\angle P$.

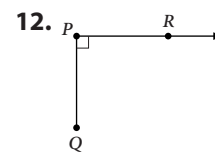
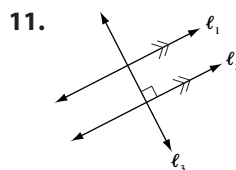

13.

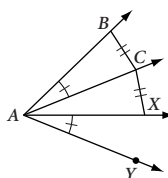

LESSON 1.4 • Polygons

Polygon name	Number of sides	Number of diagonals
1. Triangle	3	0
2. Quadrilateral	4	2
3. Pentagon	5	5
4. Hexagon	6	9
5. Heptagon	7	14
6. Octagon	8	20
7. Decagon	10	35
8. Dodecagon	12	54

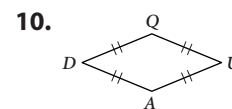
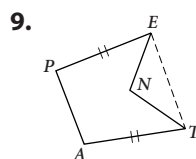

11. $\overline{AC}, \overline{AD}, \overline{AE}$

12. Possible answer: \overline{AB} and \overline{BC}

13. Possible answer: $\angle A$ and $\angle B$

14. Possible answer: \overline{AC} and \overline{FD}

15. 82° 16. 7.2 17. 61° 18. 16.1

19. 6.2 cm

LESSON 1.5 • Triangles

For Exercises 1–7, answers will vary. Possible answers are shown.

1. $\overline{AB} \parallel \overline{GH}$

2. $\overline{EF} \perp \overline{BI}$

3. $\overline{CG} \cong \overline{FH}$

4. $\angle DEG$ and $\angle GEF$

5. $\angle DEG$ and $\angle GEF$

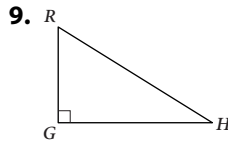
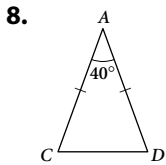
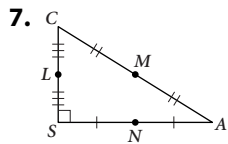
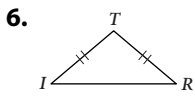

For Exercises 10–12, answers may vary. Possible answers are shown.

10. $F(8, -2)$

11. $D(4, 3)$

12. $G(10, -2)$

LESSON 1.6 • Special Quadrilaterals

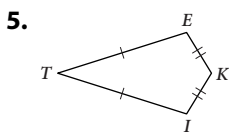
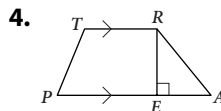
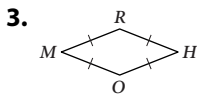
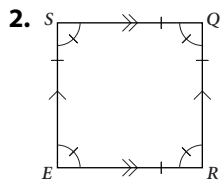
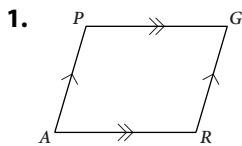

For Exercises 6–10, 12, and 13, answers may vary. Possible answers are shown.

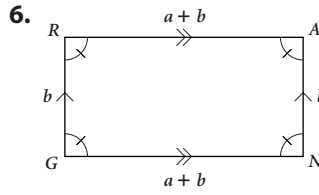

7. $ACFD$ 8. $EFHG$ 9. $BFJD$ 10. $BFHD$

11. $D(0, 3)$ 12. $E(0, 5)$ 13. $G(16, 3)$

LESSON 1.7 • Circles

1. 48° 2. 132° 3. 228° 4. 312°

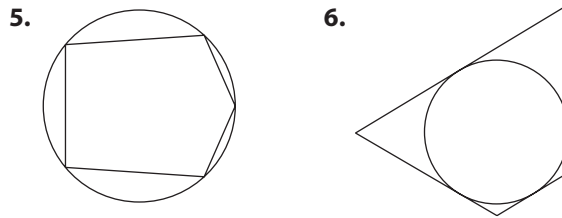

7. $(8, 2); (3, 7); (3, -3)$

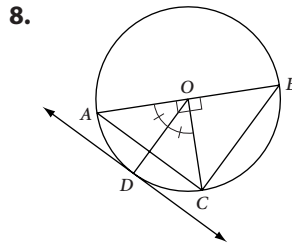

9. The chord goes through the center, P . (It is a diameter.)

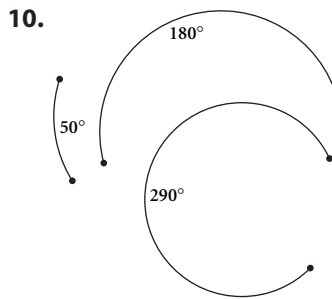
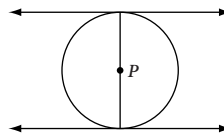

11. Kite

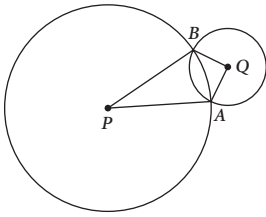

LESSON 1.8 • Space Geometry

1.

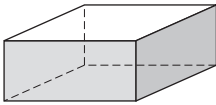

2.

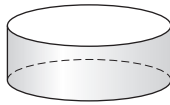

3. Rectangular prism

4. Pentagonal prism

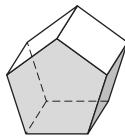
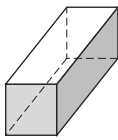

5.



6.



7. 18 cubes

8. $x = 2, y = 1$

LESSON 1.9 • A Picture Is Worth a Thousand Words

1.

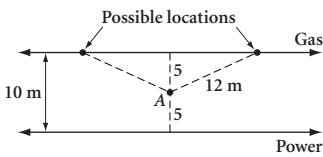

2. Dora, Ellen, Charles, Anica, Fred, Bruce

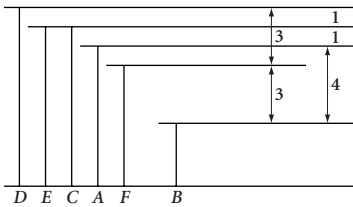

3.

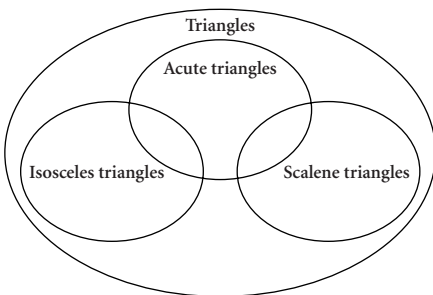

4. Possible answers:

a.

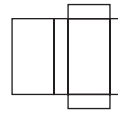

b.



c.

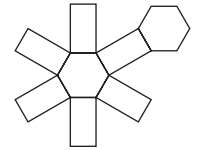

LESSON 2.1 • Inductive Reasoning

1. 20, 24

2. $12\frac{1}{2}, 6\frac{1}{4}$

3. $\frac{5}{4}, 2$

4. -1, -1

5. 72, 60

6. 243, 729

7. 91, 140

8.

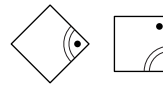

9.

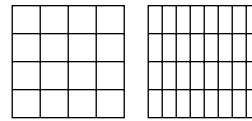

10.

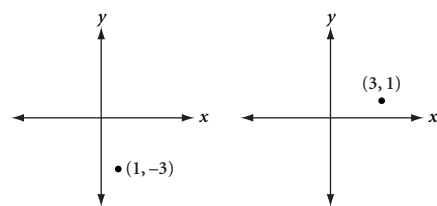

11. False; $(\frac{1}{2})^2 = \frac{1}{4}$

12. False; $11 \cdot 10 = 110, 11 \cdot 12 = 132$

13. True

LESSON 2.2 • Finding the n th Term

1. Linear 2. Linear 3. Not linear

4. Linear

5.

n	1	2	3	4	5
$f(n)$	-5	2	9	16	23

6.

n	1	2	3	4	5
$g(n)$	-10	-18	-26	-34	-42

7. $f(n) = 4n + 5; f(50) = 205$

8. $f(n) = -5n + 11; f(50) = -239$

9. $f(n) = \frac{1}{2}n + 6; f(50) = 31$

10.

n	1	2	3	4	5	...	n	...	50
Number of triangles	1	5	9	13	17	...	$4n - 3$...	197

11.

n	1	2	3	4	5	...	n	...	50
Area of figure	1	4	16	64	256	...	4^{n-1}	...	4^{49}

LESSON 2.3 • Mathematical Modeling

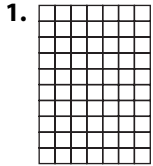

- a. 240
- b. 1350
- c. $f(n) = 2n(n + 2)$, or $f(n) = 2n^2 + 4n$

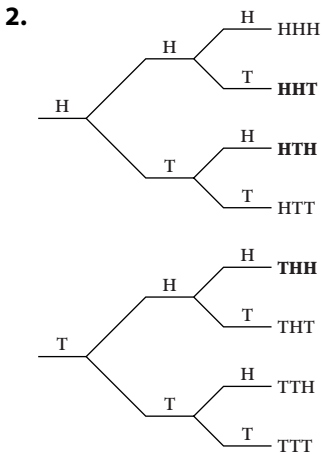

- a. 8 sequences
 - b. 3 sequences have 1 tail.
 - c. $\frac{3}{8}$
3. 66 different pairs. Use a dodecagon showing sides and diagonals.

4. Answers will vary. Possible answers:

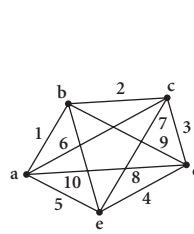

5 teams, 10 games

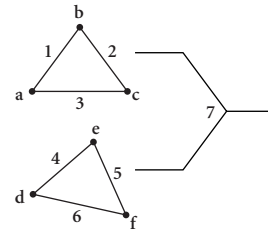

6 teams, 7 games

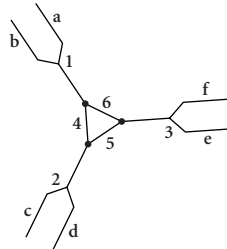

6 teams, 6 games

LESSON 2.4 • Deductive Reasoning

- 1. No. Explanations will vary. Sample explanation: Because $\triangle ABC$ is equilateral, $AB = BC$. Because C lies between B and D , $BD > BC$, so BD is not equal to AB . Thus $\triangle ABD$ is not equilateral, by deductive reasoning.
- 2. Answers will vary. $m\angle E > m\angle D$ ($m\angle E = m\angle D + 90^\circ$); deductive
- 3. a, e, f; inductive
- 4. Deductive
 - a. $4x + 3(2 - x) = 8 - 2x$ The original equation.
 - $4x + 6 - 3x = 8 - 2x$ Distributive property.
 - $x + 6 = 8 - 2x$ Combining like terms.
 - $3x + 6 = 8$ Addition property of equality.
 - $3x = 2$ Subtraction property of equality.
 - $x = \frac{2}{3}$ Division property of equality.

b. $\frac{19 - 2(3x - 1)}{5} = x + 2$ The original equation.
 $19 - 2(3x - 1) = 5(x + 2)$ Multiplication property of equality.
 $19 - 6x + 2 = 5x + 10$ Distributive property.
 $21 - 6x = 5x + 10$ Combining like terms.
 $21 = 11x + 10$ Addition property of equality.
 $11 = 11x$ Subtraction property of equality.
 $1 = x$ Division property of equality.

5. a. 16, 21; inductive
 b. $f(n) = 5n - 9$; 241; deductive

LESSON 2.5 • Angle Relationships

- $a = 68^\circ, b = 112^\circ, c = 68^\circ$
- $a = 127^\circ$
- $a = 35^\circ, b = 40^\circ, c = 35^\circ, d = 70^\circ$
- $a = 90^\circ, b = 90^\circ, c = 42^\circ, d = 48^\circ, e = 132^\circ$
- $a = 20^\circ, b = 70^\circ, c = 20^\circ, d = 70^\circ, e = 110^\circ$
- $a = 70^\circ, b = 55^\circ, c = 25^\circ$
- Sometimes
- Always
- Never
- Sometimes
- acute
- 158°
- 90°
- obtuse
- converse

LESSON 2.6 • Special Angles on Parallel Lines

- $a = 54^\circ, b = 54^\circ, c = 54^\circ$
- $a = 115^\circ, b = 65^\circ, c = 115^\circ, d = 65^\circ$
- $a = 72^\circ, b = 126^\circ$
- $\ell_1 \parallel \ell_2$
- $\ell_1 \not\parallel \ell_2$
- cannot be determined
- $a = 102^\circ, b = 78^\circ, c = 58^\circ, d = 122^\circ, e = 26^\circ, f = 58^\circ$
- $x = 80^\circ$
- $x = 20^\circ, y = 25^\circ$

LESSON 3.1 • Duplicating Segments and Angles

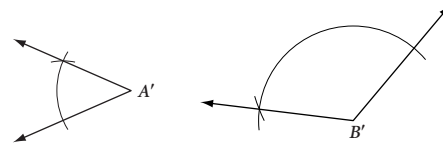

2. $XY = 3PQ - 2RS$



3. Possible answer:
 $128^\circ - 35^\circ = 93^\circ$

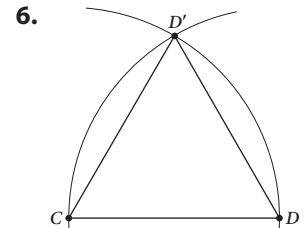
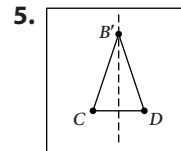
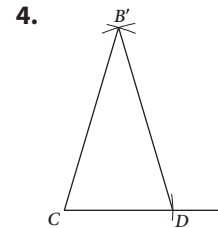
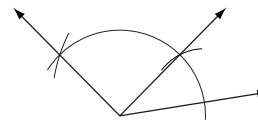

LESSON 3.2 • Constructing Perpendicular Bisectors

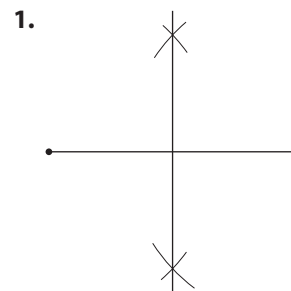

2. Square

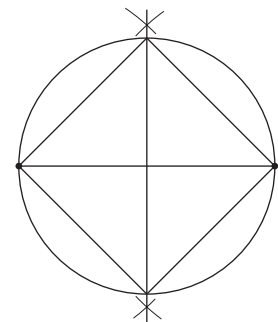

3. $XY = \frac{5}{4}AB$

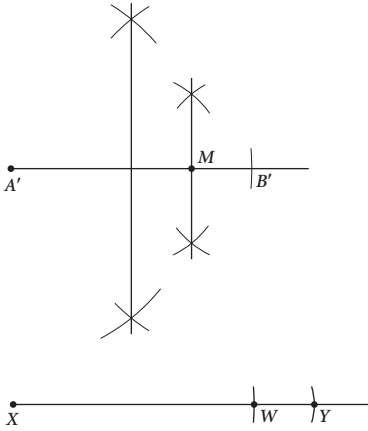

4. $\triangle ABC$ is not unique.

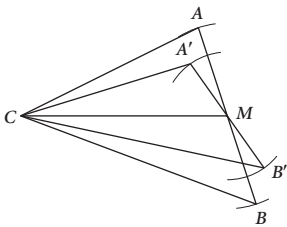

5. $\triangle ABC$ is not unique.

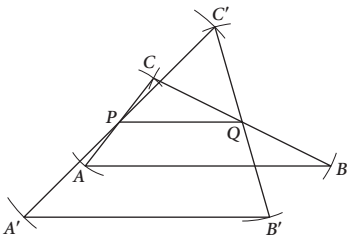

6. $BD = AD = CD$

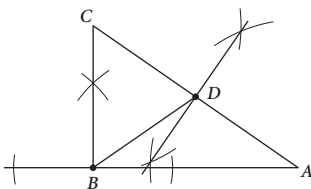

7. a. A and B
 b. A, B, and C
 c. A and B and from C and D (but not from B and C)
 d. A and B and from D and E

LESSON 3.3 • Constructing Perpendiculars to a Line

1. False. The altitude from A coincides with the side so it is not shorter.

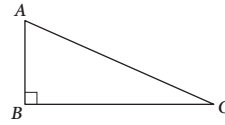

2. False. In an isosceles triangle, an altitude and median coincide so they are of equal length.

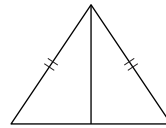

3. True

4. False. In an acute triangle, all altitudes are inside. In a right triangle, one altitude is inside and two are sides. In an obtuse triangle, one altitude is inside and two are outside. There is no other possibility so exactly one altitude is never outside.

5. False. In an obtuse triangle, the intersection of the perpendicular bisectors is outside the triangle.

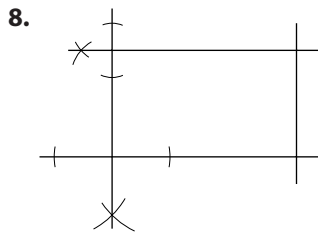
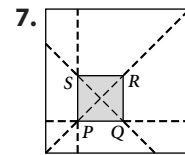
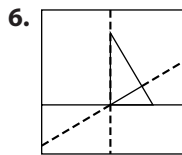

9. $WX = YZ$

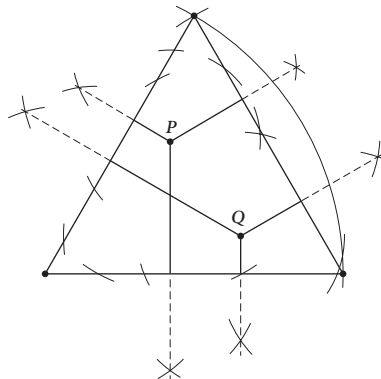

LESSON 3.4 • Constructing Angle Bisectors

1. a. l_1 and l_2
 b. $l_1, l_2,$ and l_3
 c. $l_2, l_3,$ and l_4
 d. l_1 and l_2 and from l_3 and l_4

2. \overline{AP} is the bisector of $\angle CAB$

3. $x = 20^\circ, m\angle ABE = 50^\circ$

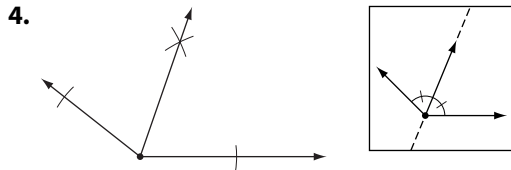

5. They are concurrent.

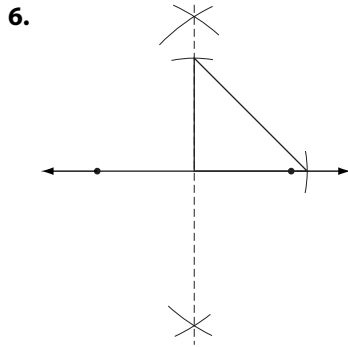
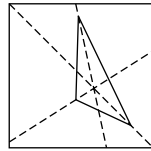

7. $RN = GN$ and $RO = HO$

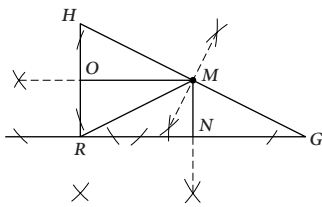

LESSON 3.5 • Constructing Parallel Lines

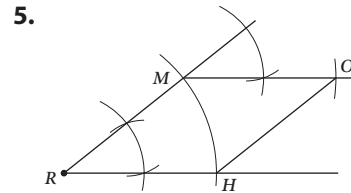
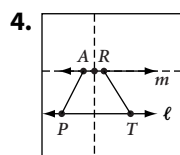
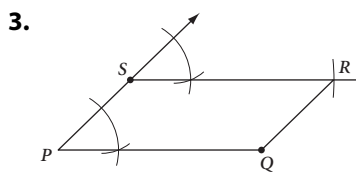
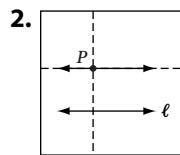
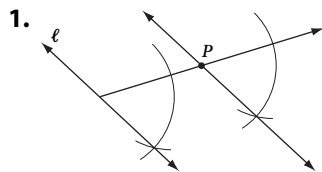

6. Possible answer:

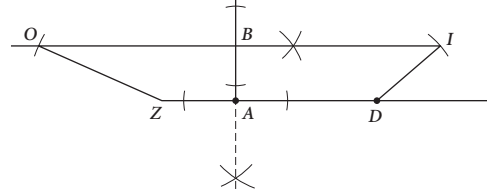

LESSON 3.6 • Construction Problems

1. Possible answer:

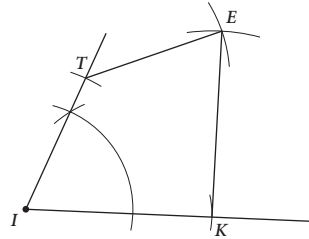

2. Possible answer:

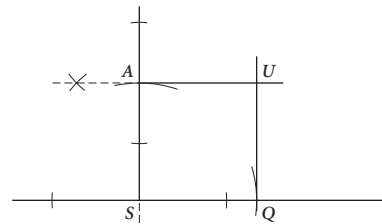
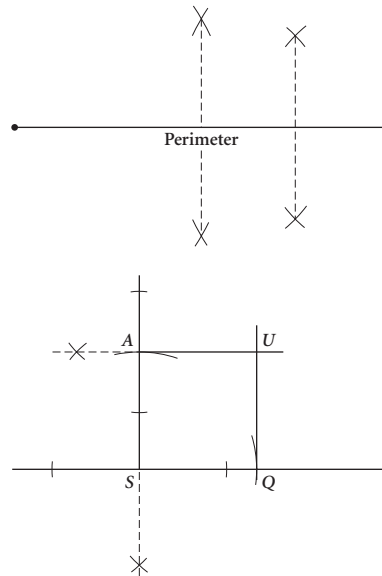

3. Possible answers:

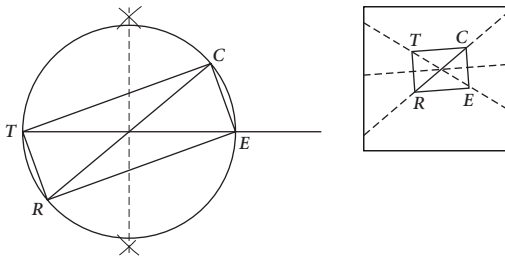

4. Possible answer:

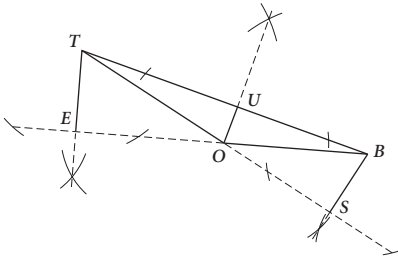

5. Possible answer:

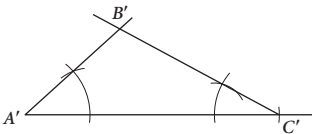

6. Possible answer:

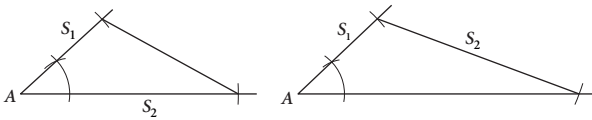

7. Possible answer:

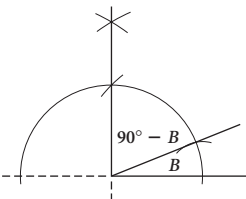
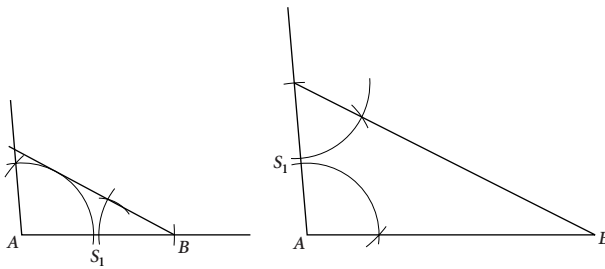

8.

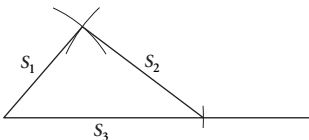

LESSON 3.7 • Constructing Points of Concurrency

1. Circumcenter

2. Locate the power-generation plant at the incenter. Locate each transformer at the foot of the perpendicular from the incenter to each side.

3.

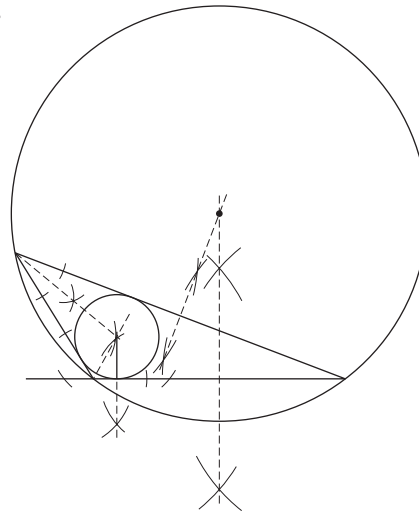

4. Possible answer: In the equilateral triangle, the centers of the inscribed and circumscribed circles are the same. In the obtuse triangle, one center is outside the triangle.

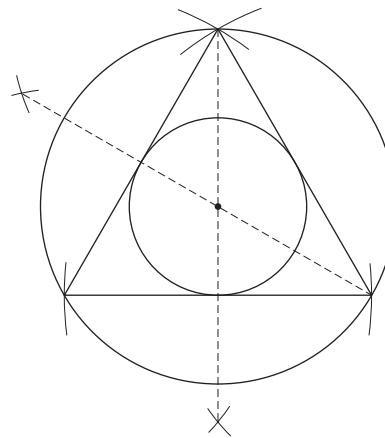

5. Possible answer: In an acute triangle, the circumcenter is inside the triangle. In a right triangle, it is on the hypotenuse. In an obtuse triangle, the circumcenter is outside the triangle. (Constructions not shown.)

LESSON 3.8 • The Centroid

1.

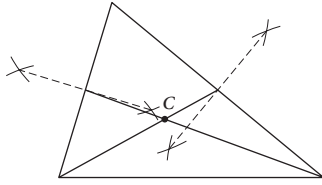

2.

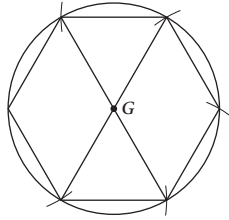

3. $CP = 3.3$ cm, $CQ = 5.7$ cm, $CR = 4.8$ cm

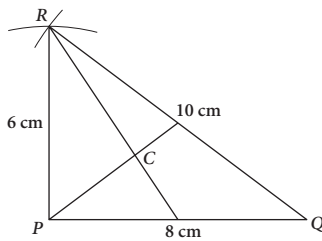

4. (3, 4)

5. $PC = 16$, $CL = 8$, $QM = 15$, $CR = 14$

- | | |
|-----------------|-----------------|
| 6. a. Incenter | b. Centroid |
| c. Circumcenter | d. Circumcenter |
| e. Orthocenter | f. Incenter |
| g. Centroid | |

LESSON 4.1 • Triangle Sum Conjecture

- | | |
|--|------------------------------------|
| 1. $p = 67^\circ$, $q = 15^\circ$ | 2. $x = 82^\circ$, $y = 81^\circ$ |
| 3. $a = 78^\circ$, $b = 29^\circ$ | |
| 4. $r = 40^\circ$, $s = 40^\circ$, $t = 100^\circ$ | |
| 5. $x = 31^\circ$, $y = 64^\circ$ | 6. $y = 145^\circ$ |
| 7. $s = 28^\circ$ | 8. $m = 72\frac{1}{2}^\circ$ |
| 9. $m\angle P = a$ | 10. $m\angle QPT = 135^\circ$ |
11. 720°

12. The sum of the measures of $\angle A$ and $\angle B$ is 90° because $m\angle C$ is 90° and all three angles must be 180° . So, $\angle A$ and $\angle B$ are complementary.
13. $m\angle BEA = m\angle CED$ because they are vertical angles. Because the measures of all three angles in each triangle add to 180° , if equal measures are subtracted from each, what remains will be equal.

LESSON 4.2 • Properties of Isosceles Triangles

- | | |
|---|-----------------------------|
| 1. $m\angle T = 64^\circ$ | 2. $m\angle G = 45^\circ$ |
| 3. $x = 125^\circ$ | |
| 4. $m\angle A = 39^\circ$, perimeter of $\triangle ABC = 46$ cm | |
| 5. $LM = 163$ m, $m\angle M = 50^\circ$ | |
| 6. $m\angle Q = 44^\circ$, $QR = 125$ | |
| 7. a. $\angle DAB \cong \angle ABD \cong \angle BDC \cong \angle BCD$ | |
| b. $\angle ADB \cong \angle CBD$ | |
| c. $\overline{AD} \parallel \overline{BC}$ by the Converse of the AIA Conjecture. | |
| 8. $x = 21^\circ$, $y = 16^\circ$ | 9. $m\angle QPR = 15^\circ$ |
10. $m\angle PRQ = 55^\circ$ by VA, which makes $m\angle P = 55^\circ$ by the Triangle Sum Conjecture. So, $\triangle PQR$ is isosceles by the Converse of the Isosceles Triangle Conjecture.

LESSON 4.3 • Triangle Inequalities

1. Yes
2. No
-
- | | |
|-------------------|--------------------|
| 3. $19 < x < 53$ | 4. $b > a > c$ |
| 5. $b > c > a$ | 6. $a > c = d > b$ |
| 7. $x = 76^\circ$ | 8. $x = 79^\circ$ |
9. The interior angle at A is 60° . The interior angle at B is 20° . But now the sum of the measures of the triangle is not 180° .
10. By the Exterior Angles Conjecture, $2x = x + m\angle PQS$. So, $m\angle PQS = x$. So, by the Converse of the Isosceles Triangle Conjecture, $\triangle PQS$ is isosceles.
11. Not possible. $AB + BC < AC$

12.

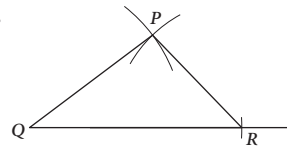

LESSON 4.4 • Are There Congruence Shortcuts?

- | | | |
|--------------------------|--------------------------|--------|
| 1. SAA or ASA | 2. SSS | 3. SSS |
| 4. $\triangle BQM$ (SAS) | 5. $\triangle TIE$ (SSS) | |

6. Cannot be determined, as shown by the figure.

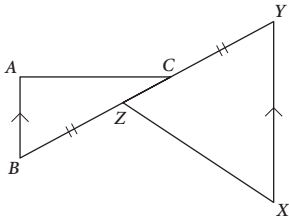

7. $\triangle TNO$ (SAS)

8. Cannot be determined, as shown by the figure.

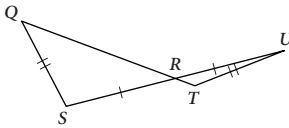

9. $\triangle DOG$ (SAS)

10. Only one triangle because of SSS.

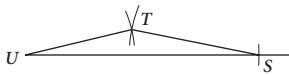

11. Two possible triangles.

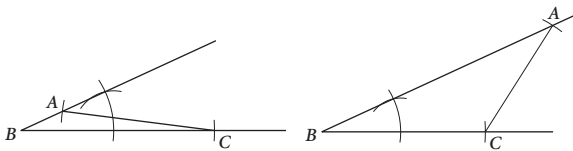

12. Only one triangle because of SAS.

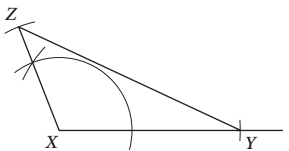

LESSON 4.5 • Are There Other Congruence Shortcuts?

1. Cannot be determined

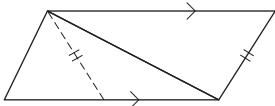

2. $\triangle XZY$ (SAA)

3. $\triangle ACB$ (ASA or SAA)

4. $\triangle PRS$ (ASA)

5. $\triangle NRA$ (SAA)

6. $\triangle GQK$ (ASA or SAA)

7. Yes, $\triangle QRS \cong \triangle MOL$ by SSS.

8. No, corresponding sides \overline{TV} and \overline{WV} are not congruent.

9. All triangles will be congruent by ASA. Possible triangle:

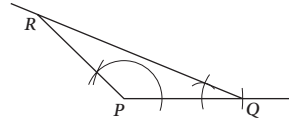

10. All triangles will be congruent by SAA. Possible procedure: Use $\angle A$ and $\angle C$ to construct $\angle B$ and then copy $\angle A$ and $\angle B$ at the ends of \overline{AB} .

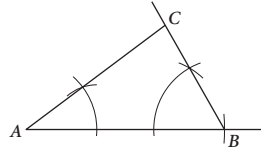

LESSON 4.6 • Corresponding Parts of Congruent Triangles

1. SSS, SAS, ASA, SAA

2. $\overline{YZ} \parallel \overline{WX}$, AIA Conjecture

3. $\overline{WZ} \parallel \overline{XY}$, AIA Conjecture

4. ASA

5. CPCTC

6. $\triangle YWM \cong \triangle ZXM$ by SAS. $\overline{YW} \cong \overline{ZX}$ by CPCTC.

7. $\triangle ACD \cong \triangle BCD$ by SAS. $\overline{AD} \cong \overline{BD}$ by CPCTC.

8. Possible answer: \overline{DE} and \overline{CF} are both the distance between \overline{DC} and \overline{AB} . Because the lines are parallel, the distances are equal. So, $\overline{DE} \cong \overline{CF}$.

9. Possible answer: $\overline{DE} \cong \overline{CF}$ (see Exercise 8). $\angle DEF \cong \angle CFE$ because both are right angles, $\overline{EF} \cong \overline{FE}$ because they are the same segment. So, $\triangle DEF \cong \triangle CFE$ by SAS. $\overline{EC} \cong \overline{FD}$ by CPCTC.

10. Possible answer: It is given that $TP = RA$ and $\angle PTR \cong \angle ART$, and $\overline{TR} \cong \overline{RT}$ because they are the same segment. So $\triangle PTR \cong \triangle ART$ by SAS and $\overline{TA} \cong \overline{RP}$ by CPCTC.

LESSON 4.7 • Flowchart Thinking

1. (See flowchart proof at bottom of page 101.)

2. (See flowchart proof at bottom of page 101.)

3. (See flowchart proof at bottom of page 101.)

LESSON 4.8 • Proving Special Triangle Conjectures

1. $AD = 8$

2. $m\angle ACD = 36^\circ$

3. $m\angle B = 52^\circ$, $CB = 13$

4. $m\angle E = 60^\circ$

5. $AN = 17$

6. Perimeter $ABCD = 104$

7. (See flowchart proof at bottom of page 102.)

8. Flowchart Proof

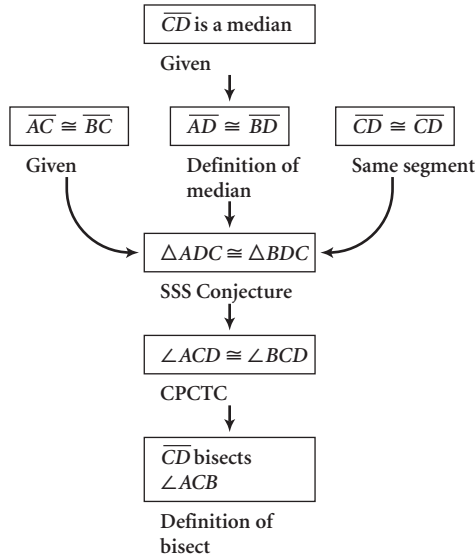

3. 170° ; 36 sides

4. 15 sides

5. $x = 105^\circ$

6. $x = 18^\circ$

7. $m\angle E = 150^\circ$

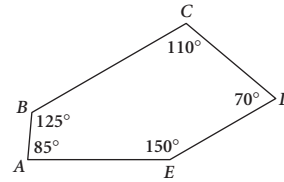

LESSON 5.2 • Exterior Angles of a Polygon

1. 12 sides

2. 24 sides

3. 4 sides

4. 6 sides

5. $a = 64^\circ$, $b = 138\frac{2}{3}^\circ$

6. $a = 102^\circ$, $b = 9^\circ$

7. $a = 156^\circ$, $b = 132^\circ$, $c = 108^\circ$

8. $a = 135^\circ$, $b = 40^\circ$, $c = 105^\circ$, $d = 135^\circ$

9.

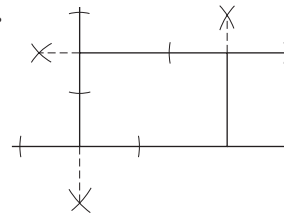

LESSON 5.1 • Polygon Sum Conjecture

1. $a = 103^\circ$, $b = 103^\circ$, $c = 97^\circ$, $d = 83^\circ$, $e = 154^\circ$

2. $a = 92^\circ$, $b = 44^\circ$, $c = 51^\circ$, $d = 85^\circ$, $e = 44^\circ$, $f = 136^\circ$

Lesson 4.7, Exercises 1, 2, 3

1.

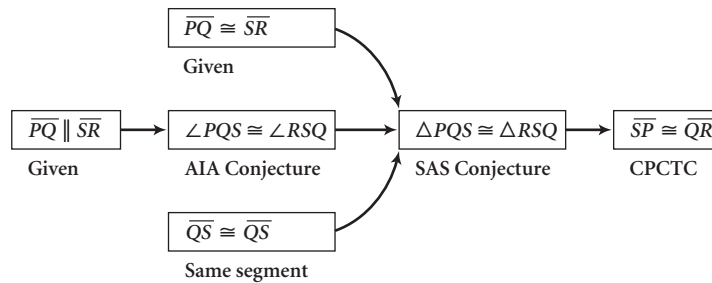

2.

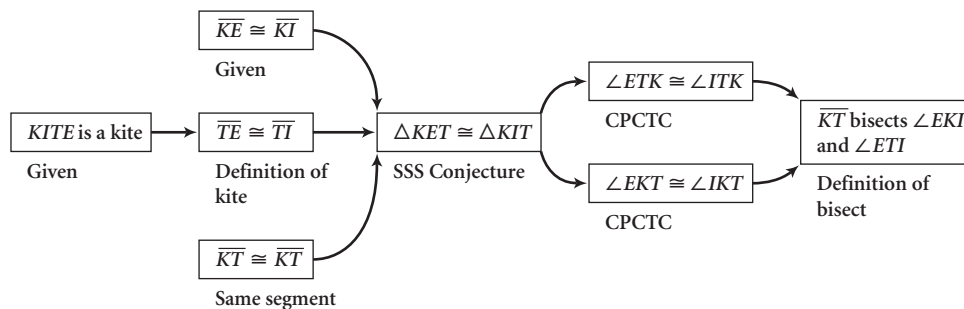

3.

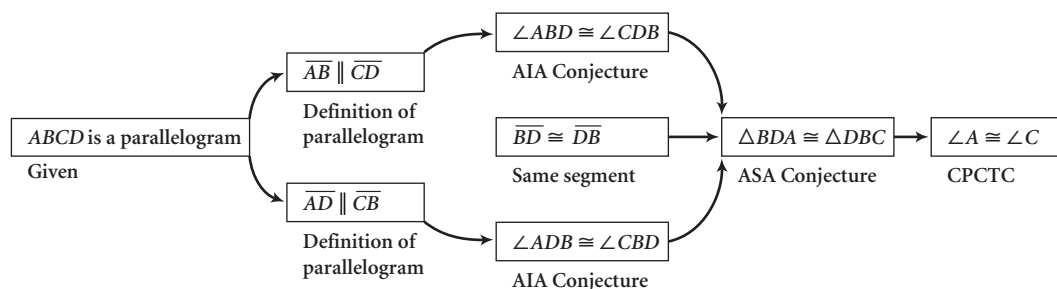

LESSON 5.3 • Kite and Trapezoid Properties

1. $x = 30$
2. $x = 124^\circ, y = 56^\circ$
3. $x = 64^\circ, y = 43^\circ$
4. $x = 12^\circ, y = 49^\circ$
5. $PS = 33$
6. $a > 11$

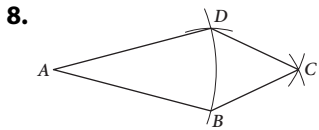
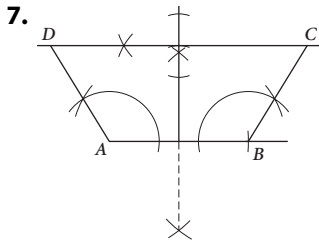

9. Possible answer:

Paragraph proof: Draw $\overline{AE} \parallel \overline{PT}$ with E on \overline{TR} . $TEAP$ is a parallelogram. $\angle T \cong \angle AER$ because they are corresponding angles of parallel lines. $\angle T \cong \angle R$ because it is given, so $\angle AER \cong \angle R$, because both are congruent to $\angle T$. Therefore, $\triangle AER$ is isosceles by the Converse of the Isosceles Triangle Conjecture. $\overline{TP} \cong \overline{EA}$ because they are opposite sides of a parallelogram and $\overline{AR} \cong \overline{EA}$ because $\triangle AER$ is isosceles. Therefore, $\overline{TP} \cong \overline{RA}$ because both are congruent to \overline{EA} .

LESSON 5.4 • Properties of Midsegments

1. $a = 89^\circ, b = 54^\circ, c = 91^\circ$
2. $x = 21, y = 7, z = 32$
3. $x = 17, y = 11, z = 6.5$
4. Perimeter $\triangle XYZ = 66, PQ = 37, ZX = 27.5$
5. $M(12, 6), N(14.5, 2)$; slope $\overline{AB} = -1.6$, slope $\overline{MN} = -1.6$
6. Pick a point P from which A and B can be viewed over land. Measure AP and BP and find the midpoints M and N . $AB = 2MN$.

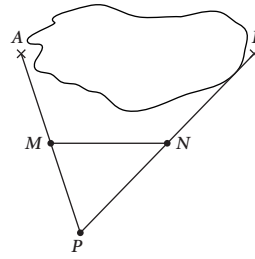

7. $AMNO$ is a parallelogram. By the Triangle Midsegment Conjecture, $\overline{ON} \parallel \overline{AM}$ and $\overline{MN} \parallel \overline{AO}$.

Flowchart Proof

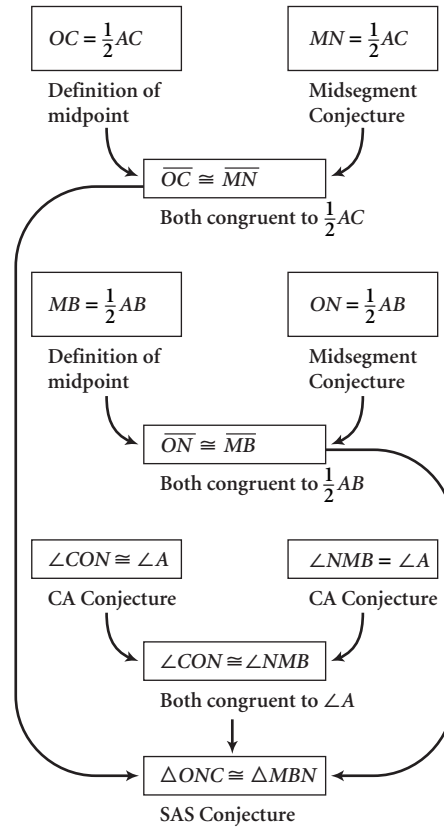

8. **Paragraph proof:** Looking at $\triangle FGR$, $\overline{HI} \parallel \overline{FG}$ by the Triangle Midsegment Conjecture. Looking at $\triangle PQR$, $\overline{FG} \parallel \overline{PQ}$ for the same reason. Because $\overline{FG} \parallel \overline{PQ}$, quadrilateral $FGQP$ is a trapezoid and \overline{DE} is the midsegment, so it is parallel to \overline{FG} and \overline{PQ} . Therefore, $\overline{HI} \parallel \overline{FG} \parallel \overline{DE} \parallel \overline{PQ}$.

Lesson 4.8, Exercise 7

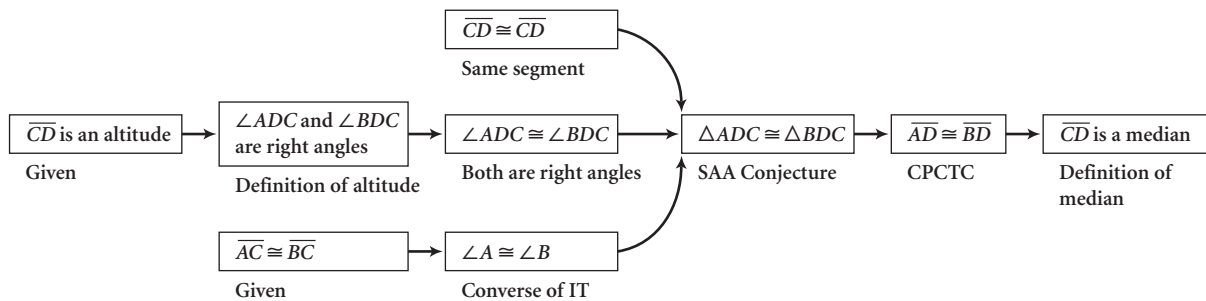

LESSON 5.5 • Properties of Parallelograms

- Perimeter $ABCD = 82$ cm
- $AC = 22$, $BD = 14$
- $AB = 16$, $BC = 7$
- $a = 51^\circ$, $b = 48^\circ$, $c = 70^\circ$
- $AB = 35.5$
- $a = 41^\circ$, $b = 86^\circ$, $c = 53^\circ$
- $AD = 75$

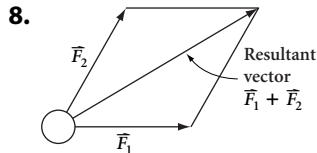

- $a = 38^\circ$, $b = 142^\circ$, $c = 142^\circ$, $d = 38^\circ$, $e = 142^\circ$,
 $f = 38^\circ$, $g = 52^\circ$, $h = 12^\circ$, $i = 61^\circ$, $j = 81^\circ$, $k = 61^\circ$
- No

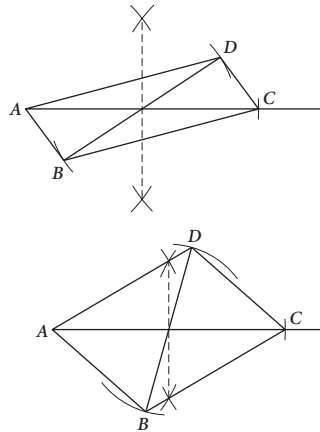

LESSON 5.6 • Properties of Special Parallelograms

- $OQ = 16$, $m\angle QRS = 90^\circ$, $PR = 32$
- $m\angle OKL = 45^\circ$, $m\angle MOL = 90^\circ$,
perimeter $KL MN = 32$
- $OB = 6$, $BC = 11$, $m\angle AOD = 90^\circ$

- c, d, f, g
- f, g
- c, d, f, g
- d, g
- None
- d, e, g
- h
- c, d, f, g
- d, g
- Parallelogram

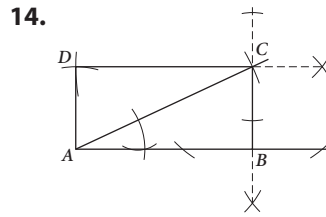

LESSON 5.7 • Proving Quadrilateral Properties

- (See flowchart proof at bottom of page.)

2. Flowchart Proof

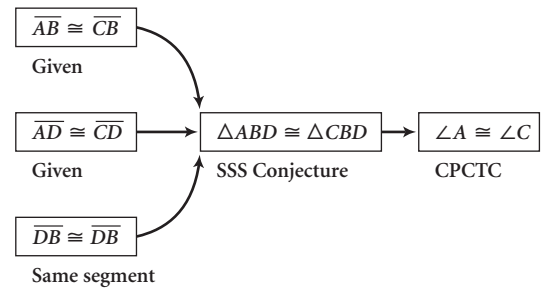

3. Flowchart Proof

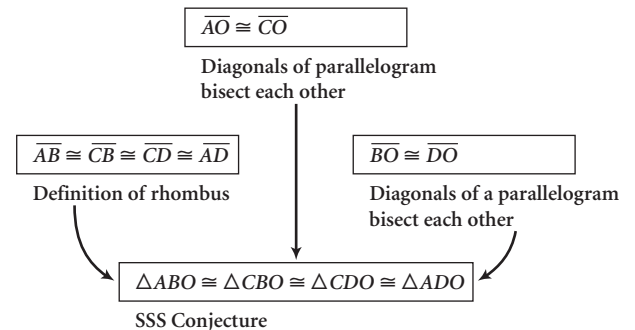

Lesson 5.7, Exercise 1

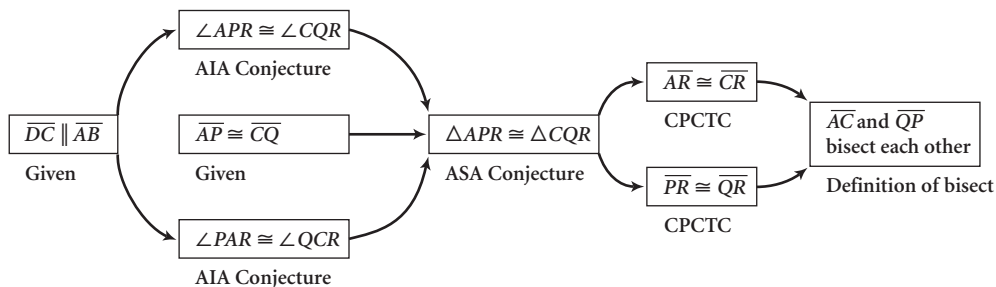

4. Flowchart Proof

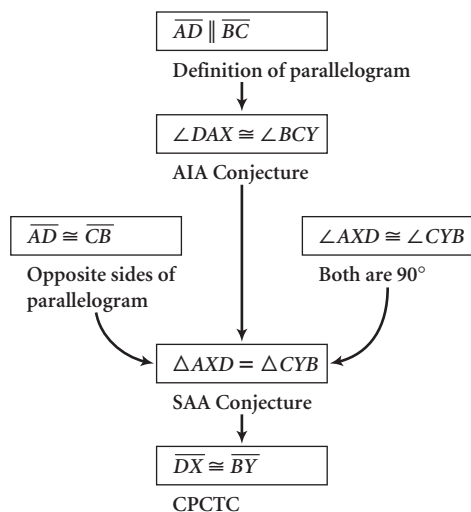

LESSON 6.1 • Tangent Properties

- $w = 126^\circ$
- $m\angle BQX = 65^\circ$
- $m\angle NQP = 90^\circ$, $m\angle MPQ = 90^\circ$
 - Trapezoid. Possible explanation: \overline{MP} and \overline{NQ} are both perpendicular to \overline{PQ} , so they are parallel to each other. The distance from M to \overline{PQ} is MP , and the distance from N to \overline{PQ} is NQ . But the two circles are not congruent, so $MP \neq NQ$. Therefore, \overline{MN} is not a constant distance from \overline{PQ} and they are not parallel. Exactly one pair of sides is parallel, so $MNQP$ is a trapezoid.
- $y = -\frac{1}{3}x + 10$
- Possible answer: Tangent segments from a point to a circle are congruent. So, $\overline{PA} \cong \overline{PB}$, $\overline{PB} \cong \overline{PC}$, and $\overline{PC} \cong \overline{PD}$. Therefore, $\overline{PA} \cong \overline{PD}$.

- 4.85 cm
- 11.55 cm

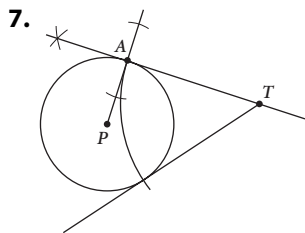

LESSON 6.2 • Chord Properties

- $a = 95^\circ$, $b = 85^\circ$, $c = 47.5^\circ$
- v cannot be determined, $w = 90^\circ$

- $z = 45^\circ$
- $w = 100^\circ$, $x = 50^\circ$, $y = 110^\circ$
- $w = 49^\circ$, $x = 122.5^\circ$, $y = 65.5^\circ$
- $x = 16$ cm, y cannot be determined
- Kite. Possible explanation: $\overline{OM} \cong \overline{ON}$ because congruent chords \overline{AB} and \overline{AC} are the same distance from the center. $\overline{AM} \cong \overline{AN}$ because they are halves of congruent chords. So, $AMON$ has two pairs of adjacent congruent sides and is a kite.
- The perpendicular segment from the center of the circle bisects the chord, so the chord has length 12 units. But the diameter of the circle is 12 units, and the chord cannot be as long as the diameter because it doesn't pass through the center of the circle.
- $P(0,1)$, $M(4, 2)$
- $m\widehat{AB} = 49^\circ$, $m\widehat{ABC} = 253^\circ$, $m\widehat{BAC} = 156^\circ$, $m\widehat{ACB} = 311^\circ$
- Possible answer: Fold and crease to match the endpoints of the arc. The crease is the perpendicular bisector of the chord connecting the endpoints. Fold and crease so that one endpoint falls on any other point on the arc. The crease is the perpendicular bisector of the chord between the two matching points. The center is the intersection of the two creases.

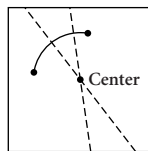

LESSON 6.3 • Arcs and Angles

- $m\angle XNM = 40^\circ$, $m\widehat{XN} = 180^\circ$, $m\widehat{MN} = 100^\circ$
- $x = 120^\circ$, $y = 60^\circ$, $z = 120^\circ$
- $a = 90^\circ$, $b = 55^\circ$, $c = 35^\circ$
- $a = 50^\circ$, $b = 60^\circ$, $c = 70^\circ$
- $x = 140^\circ$
- $m\angle A = 90^\circ$, $m\widehat{AB} = 72^\circ$, $m\angle C = 36^\circ$, $m\widehat{CB} = 108^\circ$
- $m\widehat{AD} = 140^\circ$, $m\angle D = 30^\circ$, $m\widehat{AB} = 60^\circ$, $m\widehat{DAB} = 200^\circ$
- $p = 128^\circ$, $q = 87^\circ$, $r = 58^\circ$, $s = 87^\circ$
- $a = 50^\circ$, $b = 50^\circ$, $c = 80^\circ$, $d = 50^\circ$, $e = 130^\circ$, $f = 90^\circ$, $g = 50^\circ$, $h = 50^\circ$, $j = 90^\circ$, $k = 40^\circ$, $m = 80^\circ$, $n = 50^\circ$

LESSON 6.4 • Proving Circle Conjectures

1. Flowchart Proof

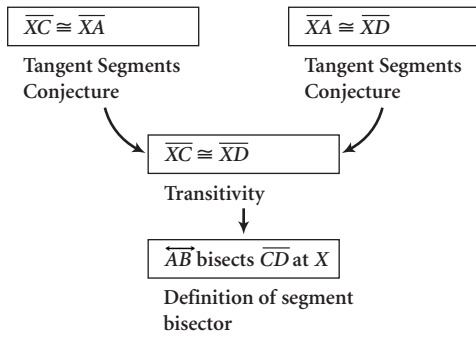

2. Angles are numbered for reference.

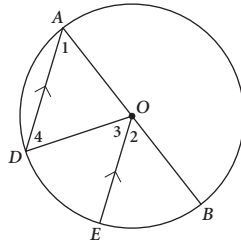

Paragraph Proof

It is given that $\overline{OE} \parallel \overline{AD}$, so $\angle 2 \cong \angle 1$ by the CA Conjecture. Because \overline{OA} and \overline{OD} are radii, they are congruent, so $\triangle AOD$ is isosceles. Therefore $\angle 4 \cong \angle 1$ by the IT Conjecture. Both $\angle 2$ and $\angle 4$ are congruent to $\angle 1$, so $\angle 2 \cong \angle 4$. By the AIA Conjecture, $\angle 4 \cong \angle 3$, so $\angle 2 \cong \angle 3$. The measure of an arc equals the measure of its central angle, so because their central angles are congruent, $\overline{DE} \cong \overline{BE}$.

3. Flowchart Proof

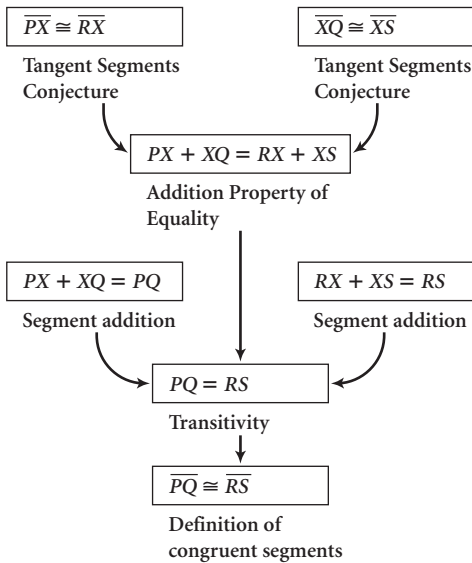

4. Flowchart Proof

Construct radii \overline{AO} , \overline{OB} , \overline{OC} , and \overline{OD} .

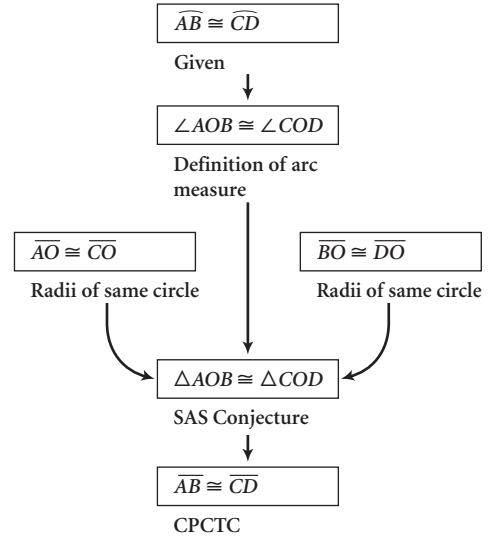

LESSON 6.5 • The Circumference/Diameter Ratio

- $C = 21\pi$ cm
- $r = 12.5$ cm
- $C = 60\pi$ cm
- $d = 24$ cm
- $C \approx 30.2$ cm
- $d \approx 42.0$ cm, $r \approx 21.0$ cm
- $C \approx 37.7$ in.
- Yes; about 2.0 in.

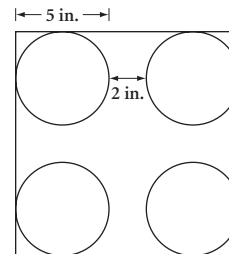

- $C \approx 75.4$ cm
- Press the square against the tree as shown. Measure the tangent segment on the square. The tangent segment is the same length as the radius. Use $C = 2\pi r$ to find the circumference.

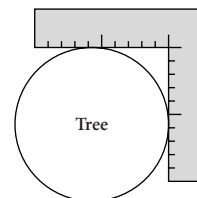

- 4 cm

LESSON 6.6 • Around the World

- At least 7 olive pieces
- About 2.5 rotations
- $\frac{(2\pi \cdot 4.23 \cdot 10^7)}{(60 \cdot 60 \cdot 23.93)} \approx 3085$ m/s (about 3 km/s or just under 2 mi/s)
- 6.05 cm or 9.23 cm
- Sitting speed = $\frac{(2\pi \cdot 1.4957 \cdot 10^{11}/10^3)}{(364.25 \cdot 24)} \approx 107,500$ km/h

LESSON 6.7 • Arc Length

- | | |
|-----------------------|-----------------------------------|
| 1. 4π | 2. 4π |
| 3. 30 | 4. $\frac{35\pi}{9}$ |
| 5. $\frac{80\pi}{9}$ | 6. 6.25π or $\frac{25\pi}{4}$ |
| 7. $\frac{100\pi}{9}$ | 8. 31.5 |
| 9. 22π | 10. 396 |

EXPLORATION • Intersection Secants, Tangents, and Chords

- $x = 21^\circ$
- $m\widehat{DC} = 70^\circ$, $m\widehat{ED} = 150^\circ$
- $m\widehat{DC} = 114^\circ$, $m\angle DEC = 66^\circ$
- $m\angle BCE = 75^\circ$, $m\widehat{BAC} = 210^\circ$
- $x = 80^\circ$, $y = 110^\circ$, $z = 141^\circ$
- $x = 34^\circ$, $y = 150^\circ$, $z = 122^\circ$
- $x = 112^\circ$, $y = 68^\circ$, $z = 53^\circ$
- $x = 28^\circ$, $y = 34.5^\circ$

LESSON 7.1 • Transformations and Symmetry

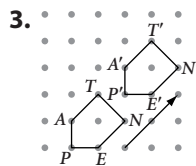
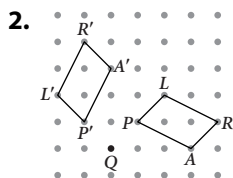
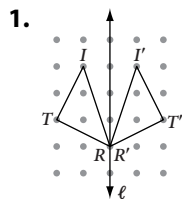

4. Possible answers: The two points where the figure and the image intersect determine ℓ . Or connect any two corresponding points and construct the perpendicular bisector, which is ℓ .

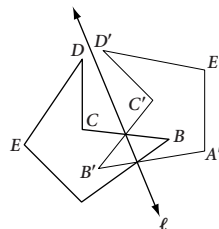

- 3-fold rotational symmetry, 3 lines of reflection
- 2-fold rotational symmetry
- 1 line of reflection
- 1 line of reflection
- 2-fold rotational symmetry, 2 lines of reflection

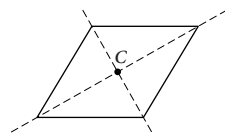

10. 2-fold rotational symmetry

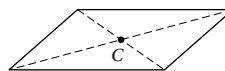

11. 1 line of reflection

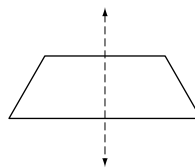

12. 4-fold rotational symmetry, 4 lines of reflection

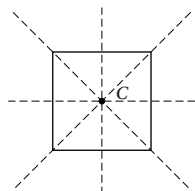

LESSON 7.2 • Properties of Isometries

1. Rotation

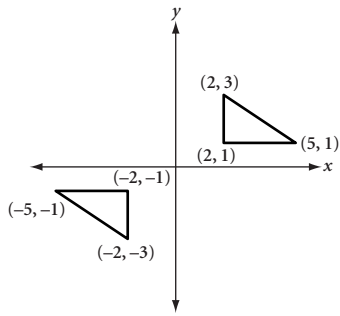

2. Translation

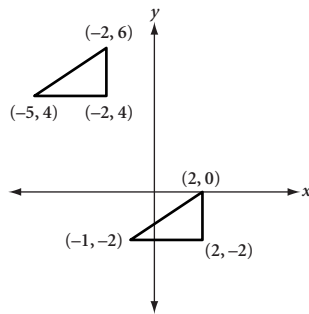

3. Reflection

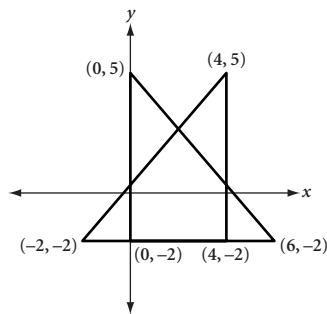

4.

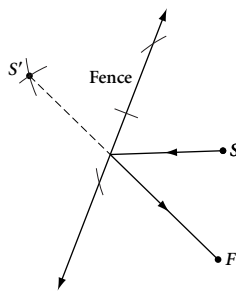

5.

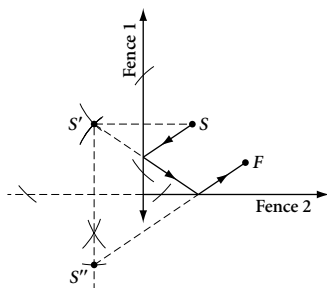

6. $(x, y) \rightarrow (x + 13, y + 6)$; translation; $B'(8, 8)$, $C(-8, -4)$
7. $(x, y) \rightarrow (-x, y)$; reflection across the y -axis; $P'(7, -3)$, $R(-4, 5)$
8. $(x, y) \rightarrow (y, x)$; reflection across the line $y = x$; $T'(7, 0)$, $R(0, 3)$

LESSON 7.3 • Compositions of Transformations

1. Translation by $\langle -2, +5 \rangle$
2. Rotation 45° counterclockwise
3. Translation by $\langle +16, 0 \rangle$
4. Rotation 180° about the intersection of the two lines
5. Translation by $\langle -16, 0 \rangle$
6. Rotation 180° about the intersection of the two lines
7. Reflection across the line $x = -3$
8. Reflection across the line $x = 3$
9. $m\angle ROT = 50^\circ$; rotation 100° clockwise about O

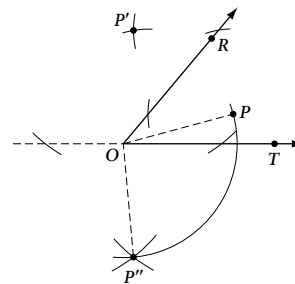

10. Translation 2 cm along the line perpendicular to k and ℓ in the direction from k to ℓ .

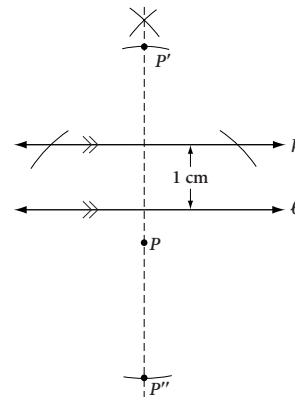

11.

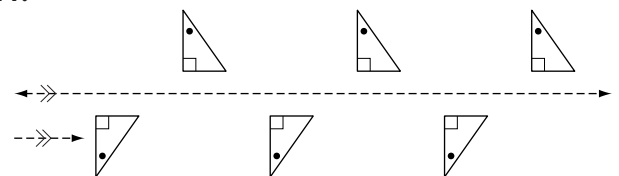

LESSON 7.4 • Tessellations with Regular Polygons

1. $n = 15$ 2. $n = 20$

3. Possible answer: A regular tessellation is a tessellation in which the tiles are congruent regular polygons whose edges exactly match.

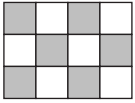

4. Possible answer: A 1-uniform tiling is a tessellation in which all vertices are identical.

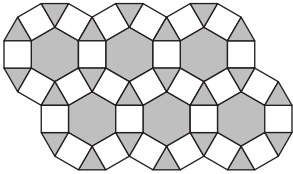

5. $3.4^2.6/3.6.3.6$

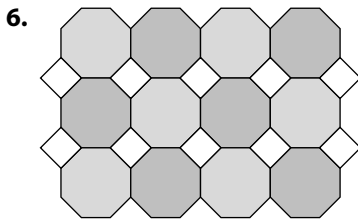

LESSONS 7.5–7.8 • Tessellations

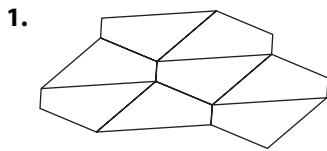

2. Sample answer:

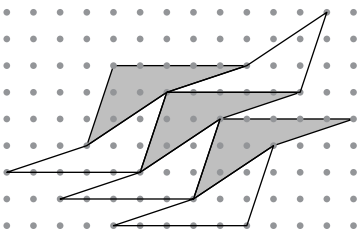

3. Sample answer:

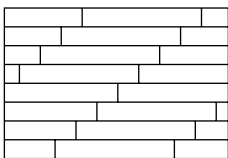

4. Sample answer:

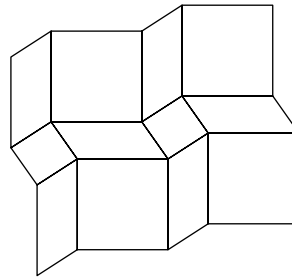

LESSON 8.1 • Areas of Rectangles and Parallelograms

1. 112 cm^2 2. 7.5 cm^2 3. 110 cm^2 4. 81 cm^2

5. 61 m

6. No. Possible answer:

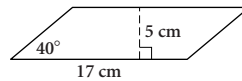
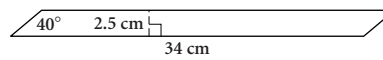

7. 88 units^2

8. 72 units^2

9. No. Carpet area is $20 \text{ yd}^2 = 180 \text{ ft}^2$. Room area is $(21.5 \text{ ft})(16.5 \text{ ft}) = 206.25 \text{ ft}^2$. Dana will be $26\frac{1}{4} \text{ ft}^2$ short.

LESSON 8.2 • Areas of Triangles, Trapezoids, and Kites

1. 16 ft

2. 20 cm^2

3. $b = 12 \text{ in.}$

4. $AD = 4.8 \text{ cm}$

5. 40 cm^2

6. 88 cm^2

7. 54 units^2

8. 135 cm^2

LESSON 8.3 • Area Problems

1. a. 549.5 ft^2

b. 40 bundles; \$1596.00

2. 500 L

3. Possible answer:

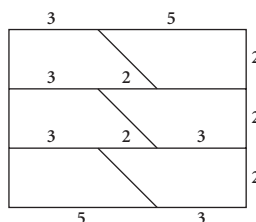
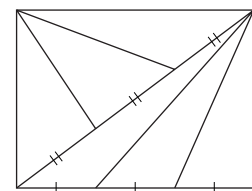
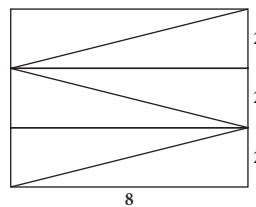

4. It is too late to change the area. The length of the diagonals determines the area.

LESSON 8.4 • Areas of Regular Polygons

1. $A \approx 696 \text{ cm}^2$ 2. $a \approx 7.8 \text{ cm}$
 3. $p \approx 43.6 \text{ cm}$ 4. $n = 10$
 5. $s = 4 \text{ cm}$, $a \approx 2.8 \text{ cm}$, $A \approx 28 \text{ cm}^2$

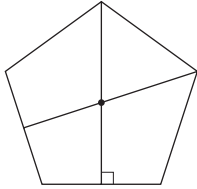

6. Possible answer (s will vary): $s \approx 3.1 \text{ cm}$, $a \approx 3.7 \text{ cm}$, $A \approx 45.9 \text{ cm}^2$

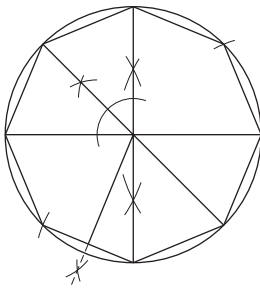

7. Approximately 31.5 cm^2 : area of square = 36; area of square within angle = $\frac{3}{8} \cdot 36 = 13.5$; area of octagon ≈ 120 ; area of octagon within angle $\approx \frac{3}{8} \cdot 120 \approx 45$; shaded area $\approx 45 - 13.5 \approx 31.5 \text{ cm}^2$

LESSON 8.5 • Areas of Circles

1. $81\pi \text{ cm}^2$ 2. $10.24\pi \text{ cm}^2$ 3. 23 cm
 4. $324\pi \text{ cm}^2$ 5. 191.13 cm^2 6. 41.41 cm
 7. 7.65 cm^2 8. 4.90 cm^2 9. 51.3 cm^2
 10. 33.5 or 33.6 cm^2
 11. $(64\pi - 128)$ square units
 12. $25\pi \text{ cm}^2$

LESSON 8.6 • Any Way You Slice It

1. $\frac{25\pi}{12} \text{ cm}^2 \approx 6.54 \text{ cm}^2$
 2. $\frac{32\pi}{3} \text{ cm}^2 \approx 33.51 \text{ cm}^2$
 3. $12\pi \text{ cm}^2 \approx 37.70 \text{ cm}^2$
 4. $(16\pi - 32) \text{ cm}^2 \approx 18.27 \text{ cm}^2$
 5. $13.5\pi \text{ cm}^2 \approx 42.41 \text{ cm}^2$

6. $10\pi \text{ cm}^2 \approx 31.42 \text{ cm}^2$

7. $r = 10 \text{ cm}$ 8. $x = 135^\circ$ 9. $r = 7 \text{ cm}$

LESSON 8.7 • Surface Area

1. 136 cm^2 2. 240 cm^2 3. 558.1 cm^2
 4. 796.4 cm^2 5. 255.6 cm^2 6. 356 cm^2
 7. 468 cm^2 8. 1055.6 cm^2
 9. 1 sheet: front rectangle: $3 \cdot 1\frac{1}{2} = 4\frac{1}{2}$; back rectangle: $3 \cdot 2\frac{1}{2} = 7\frac{1}{2}$; bottom rectangle: $3 \cdot 2 = 6$;
 side trapezoids: $2\left(2 \cdot \frac{2\frac{1}{2} + 1\frac{1}{2}}{2}\right) = 8$; total = 26 ft^2 .
 Area of 1 sheet = $4 \cdot 8 = 32 \text{ ft}^2$. Possible pattern:

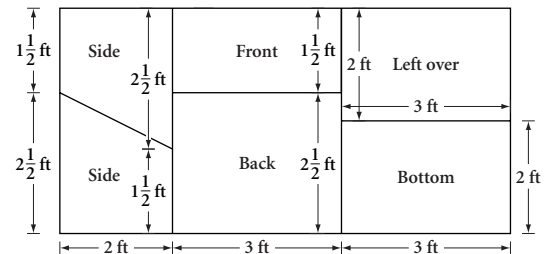

LESSON 9.1 • The Theorem of Pythagoras

1. $a = 21 \text{ cm}$ 2. $p \approx 23.9 \text{ cm}$
 3. $x = 8 \text{ ft}$ 4. $h \approx 14.3 \text{ in.}$
 5. Area $\approx 19.0 \text{ ft}^2$ 6. $C(11, -1)$; $r = 5$
 7. Area $\approx 49.7 \text{ cm}^2$ 8. $RV \approx 15.4 \text{ cm}$
 9. If the base area is $16\pi \text{ cm}^2$, then the radius is 4 cm . The radius is a leg of the right triangle; the slant height is the hypotenuse. The leg cannot be longer than the hypotenuse.
 10. Area = 150 in^2 ; hypotenuse $QR = 25 \text{ in.}$; altitude to the hypotenuse = 12 in.

LESSON 9.2 • The Converse of the Pythagorean Theorem

1. No 2. Yes 3. Yes 4. Yes
 5. Area $\approx 21.22 \text{ cm}^2$
 6. The top triangle is equilateral, so half its side length is 2.5 . A triangle with sides 2.5 , 6 , and 6.5 is a right triangle because $2.5^2 + 6^2 = 6.5^2$. So, the angle marked 95° should be 90° .
 7. $x \approx 44.45 \text{ cm}$. By the Converse of the Pythagorean Theorem, $\triangle ADC$ is a right triangle, and $\angle ADC$ is a right angle. $\angle ADC$ and $\angle BDC$ are supplementary, so $\angle BDC$ is also a right angle. Use the Pythagorean Theorem to find x .

8. 129.6 cm^2

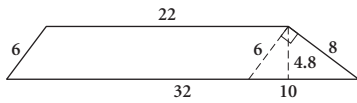

9. No. Because $AB^2 + BC^2 \neq AC^2$, $\angle B$ of $\triangle ABC$ is not a right angle.

10. Cannot be determined. The length of CD is unknown. One possible quadrilateral is shown.

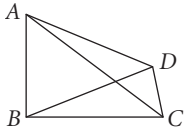

11. Yes. Using SSS, $\triangle ABC \cong \triangle BAD \cong \triangle CDA \cong \triangle DCB$. That means that the four angles of the quadrilateral are all congruent by CPCTC. Because the four angles must sum to 360° and they are all congruent, they must be right angles. So, $ABCD$ is a rectangle.

LESSON 9.3 • Two Special Right Triangles

- $a = 14\sqrt{2} \text{ cm}$
- $a = 12 \text{ cm}, b = 24 \text{ cm}$
- $a = 12 \text{ cm}, b = 6\sqrt{3} \text{ cm}$
- $64\sqrt{3} \text{ cm}^2$
- Perimeter = $32 + 6\sqrt{2} + 6\sqrt{3} \text{ cm}$;
area = $60 + 18\sqrt{3} \text{ cm}^2$
- $AC = 30\sqrt{2} \text{ cm}; AB = 30 + 30\sqrt{3} \text{ cm}$;
area = $450 + 450\sqrt{3} \text{ cm}^2$
- $45\sqrt{3} \text{ cm}^2$
- $C\left(-\frac{1}{2}, \frac{\sqrt{3}}{2}\right)$
- $C(-6\sqrt{3}, -6)$

10. Possible answer:

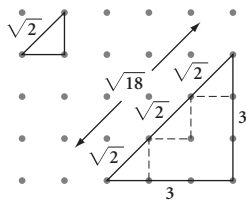

LESSON 9.4 • Story Problems

1. The foot is about 8.7 ft away from the base of the building. To lower it by 2 ft, move the foot an additional 3.3 ft away from the base of the building.

2. About 6.4 km

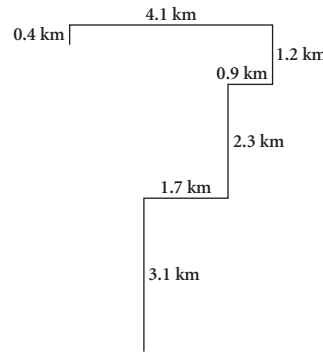

3. 149.5 linear feet of trim must be painted, or 224.3 feet^2 . Two coats means 448.6 feet^2 of coverage. Just over $2\frac{1}{2}$ quarts of paint is needed. If Hans buys 3 quarts, he would have almost $\frac{1}{2}$ quart left. It is slightly cheaper to buy 1 gallon and have about $1\frac{1}{2}$ quarts left. The choice is one of money versus conserving. Students may notice that the eaves extend beyond the exterior walls of the house and adjust their answer accordingly.

4. $14 \text{ in.}, \frac{14}{\sqrt{3}} \text{ in.} \approx 8.08 \text{ in.}, \frac{28}{\sqrt{3}} \text{ in.} \approx 16.17 \text{ in.}$

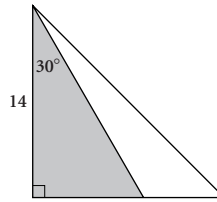

LESSON 9.5 • Distance in Coordinate Geometry

- 10 units 2. 20 units 3. 17 units
- $ABCD$ is a rhombus: All sides = $\sqrt{34}$, slope $\overline{AB} = -\frac{3}{5}$, slope $\overline{BC} = \frac{3}{5}$, so $\angle B$ is not a right angle, and $ABCD$ is not a square.
- $TUVW$ is an isosceles trapezoid: \overline{TU} and \overline{VW} have slope 1, so they are parallel. \overline{UV} and \overline{TW} have length $\sqrt{20}$ and are not parallel (slope $\overline{UV} = -\frac{1}{2}$, slope $\overline{TW} = -2$).
- Isosceles; perimeter = 32 units
- $M(7, 10); N(10, 14)$; slope $\overline{MN} = \frac{4}{3}$, slope $\overline{BC} = \frac{4}{3}$;
 $MN = 5; BC = 10$; the slopes are equal;
 $MN = \frac{1}{2}BC$.
- $(x + 1)^2 + (y - 5)^2 = 4$ 9. Center $(0, -2), r = 5$
- The distances from the center to the three points on the circle are not all the same: $AP = \sqrt{61}$,
 $BP = \sqrt{61}, CP = \sqrt{52}$

LESSON 9.6 • Circles and the Pythagorean Theorem

- $(25\pi - 24)$ cm², or about 54.5 cm²
- $(72\sqrt{3} - 24\pi)$ cm², or about 49.3 cm²
- $(\sqrt{5338} - 37)$ cm \approx 36.1 cm
- Area = 56.57π cm \approx 177.7 cm²
- $AD = \sqrt{115.04}$ cm \approx 10.7 cm
- $ST = 9\sqrt{3} \approx 15.6$
- 150°

LESSON 10.1 • The Geometry of Solids

- oblique
- the axis
- the altitude
- bases
- a radius
- right
- Circle C
- A
- \overline{AC} or AC
- \overline{BC} or BC
- Right pentagonal prism
- $ABCDE$ and $FGHIJ$
- \overline{AF} , \overline{BG} , \overline{CH} , \overline{DI} , \overline{EJ}
- Any of \overline{AF} , \overline{BG} , \overline{CH} , \overline{DI} , \overline{EJ} or their lengths
- False. The axis is not perpendicular to the base in an oblique cylinder.
- False. A rectangular prism has six faces. Four are called lateral faces and two are called bases.

17. True

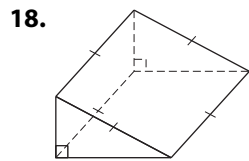

19.

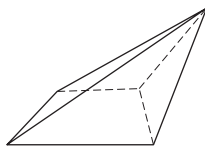

LESSON 10.2 • Volume of Prisms and Cylinders

- 232.16 cm³
- 144 cm³
- 415.69 cm³
- $V = 4xy(2x + 3)$, or $8x^2y + 12xy$
- $V = \frac{1}{4}p^2h\pi$
- $V = \left(6 + \frac{1}{2}\pi\right)x^2y$
- 6 ft³

LESSON 10.3 • Volume of Pyramids and Cones

- 80 cm³
- 209.14 cm³
- 615.75 cm³
- $V = 840x^3$
- $V = \frac{8}{3}\pi a^2b$
- $V = 4\pi xy^2$
- A:** 128π cubic units, **B:** 144π cubic units.
B is larger.
- A:** 5 cubic units, **B:** 5 cubic units.
They have equal volumes.
- A:** $9\pi x$ cubic units, **B:** $27\pi x$ cubic units. **B** is larger.

LESSON 10.4 • Volume Problems

- 4.4 cm
- 1728 in³
- 24 cans; 3582 in³ = 2.07 ft³; 34.6%
- 2000.6 lb (about 1 ton)
- Note that $\overline{AE} \perp \overline{AB}$ and $\overline{EC} \perp \overline{BC}$. $V = \frac{8}{3}$ cm³;
 $SA = (8 + 4\sqrt{2})$ cm² \approx 13.7 cm²
- About 110,447 gallons
- 57 truckloads

LESSON 10.5 • Displacement and Density

All answers are approximate.

- 53.0 cm³
- 7.83 g/cm³
- 0.54 g/cm³
- 4.94 in.
- No, it's not gold (or at least not pure gold). The mass of the nugget is 165 g, and the volume is 17.67 cm³, so the density is 9.34 g/cm³. Pure gold has density 19.3 g/cm³.

LESSON 10.6 • Volume of a Sphere

- 288π cm³, or about 904.8 cm³
- 18π cm³, or about 56.5 cm³
- 72π cm³, or about 226.2 cm³
- $\frac{28}{3}\pi$ cm³, or about 29.3 cm³
- 432π cm³, or about 1357.2 cm³
- $\frac{304}{3}\pi$ cm³, or about 318.3 cm³
- 11 cm
- 2250π in³ \approx 7068.6 in³
- 823.2 in³; 47.6%
- 17.86

LESSON 10.7 • Surface Area of a Sphere

- $V = 1563.5$ cm³; $S = 651.4$ cm²
- $V = 184.3$ cm³; $S = 163.4$ cm²

- $V = 890.1 \text{ cm}^3$; $S = 486.9 \text{ cm}^2$
- $V = 34.1 \text{ cm}^3$; $S = 61.1 \text{ cm}^2$
- About 3.9 cm
- About 357.3 cm^2
- 9 quarts

LESSON 11.1 • Similar Polygons

- $AP = 8 \text{ cm}$; $EI = 7 \text{ cm}$; $SN = 15 \text{ cm}$; $YR = 12 \text{ cm}$
- $SL = 5.2 \text{ cm}$; $MI = 10 \text{ cm}$; $m\angle D = 120^\circ$;
 $m\angle U = 85^\circ$; $m\angle A = 80^\circ$
- Yes. All corresponding angles are congruent. Both figures are parallelograms, so opposite sides within each parallelogram are equal. The corresponding sides are proportional ($\frac{15}{5} = \frac{9}{3}$).
- Yes. Corresponding angles are congruent by the CA Conjecture. Corresponding sides are proportional ($\frac{2}{4} = \frac{3}{6} = \frac{4}{8}$).
- No. $\frac{6}{18} \neq \frac{8}{22}$.
- Yes. All angles are right angles, so corresponding angles are congruent. The corresponding side lengths have the ratio $\frac{4}{7}$, so corresponding side lengths are proportional.
- $\frac{1}{2}$

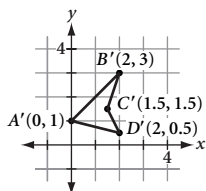

- 4 to 1

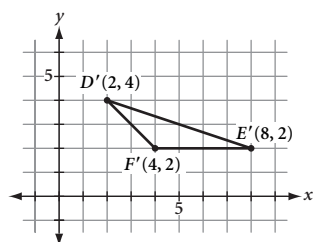

LESSON 11.2 • Similar Triangles

- $MC = 10.5 \text{ cm}$
- $\angle Q \cong \angle X$; $QR = 4.8 \text{ cm}$; $QS = 11.2 \text{ cm}$
- $\angle A \cong \angle E$; $CD = 13.5 \text{ cm}$; $AB = 10 \text{ cm}$
- $TS = 15 \text{ cm}$; $QP = 51 \text{ cm}$
- AA Similarity Conjecture

- $CA = 64 \text{ cm}$
- $\triangle ABC \sim \triangle EDC$. Possible explanation: $\angle A \cong \angle E$ and $\angle B \cong \angle D$ by AIA, so by the AA Similarity Conjecture, the triangles are similar.
- $\triangle PQR \sim \triangle STR$. Possible explanation: $\angle P \cong \angle S$ and $\angle Q \cong \angle T$ because each pair is inscribed in the same arc, so by the AA Similarity Conjecture, the triangles are similar.
- $\triangle MLK \sim \triangle NOK$. Possible explanation: $\angle MLK \cong \angle NOK$ by CA and $\angle K \cong \angle K$ because they are the same angle, so by the AA Similarity Conjecture, the two triangles are similar.

LESSON 11.3 • Indirect Measurement with Similar Triangles

- 27 ft
- 6510 ft
- 110.2 mi
- About 18.5 ft
- 0.6 m, 1.2 m, 1.8 m, 2.4 m, and 3.0 m

LESSON 11.4 • Corresponding Parts of Similar Triangles

- $h = 0.9 \text{ cm}$; $j = 4.0 \text{ cm}$
- 3.75 cm, 4.50 cm, 5.60 cm
- $WX = 13\frac{5}{7} \approx 13.7 \text{ cm}$; $AD = 21 \text{ cm}$; $DB = 12 \text{ cm}$;
 $YZ = 8 \text{ cm}$; $XZ = 6\frac{6}{7} \approx 6.9 \text{ cm}$
- $x = \frac{50}{13} \approx 3.85 \text{ cm}$; $y = \frac{80}{13} \approx 6.15 \text{ cm}$
- $a = 8 \text{ cm}$; $b = 3.2 \text{ cm}$; $c = 2.8 \text{ cm}$
- $CB = 24 \text{ cm}$; $CD = 5.25 \text{ cm}$; $AD = 8.75 \text{ cm}$

LESSON 11.5 • Proportions with Area

- 5.4 cm^2
- 4 cm
- $\frac{9}{25}$
- $\frac{36}{1}$
- $\frac{25}{4}$
- 16:25
- 2:3
- $888\frac{8}{9} \text{ cm}^2$
- 1296 tiles

LESSON 11.6 • Proportions with Volume

- Yes
- No
- 16 cm^3
- 20 cm
- 8:125
- 6 ft^2

LESSON 11.7 • Proportional Segments Between Parallel Lines

- $x = 12 \text{ cm}$
- Yes
- No
- $NE = 31.25 \text{ cm}$
- $PR = 6 \text{ cm}$; $PQ = 4 \text{ cm}$; $RI = 12 \text{ cm}$
- $a = 9 \text{ cm}$; $b = 18 \text{ cm}$

7. $RS = 22.5$ cm, $EB = 20$ cm
 8. $x = 20$ cm; $y = 7.2$ cm
 9. $p = \frac{16}{3} = 5.\bar{3}$ cm; $q = \frac{8}{3} = 2.\bar{6}$ cm

LESSON 12.1 • Trigonometric Ratios

1. $\sin P = \frac{p}{r}$ 2. $\cos P = \frac{q}{r}$
 3. $\tan P = \frac{p}{q}$ 4. $\sin Q = \frac{q}{r}$
 5. $\sin T = 0.800$ 6. $\cos T = 0.600$
 7. $\tan T \approx 1.333$ 8. $\sin R = 0.600$
 9. $x \approx 12.27$ 10. $x \approx 29.75$
 11. $x \approx 18.28$ 12. $m\angle A \approx 71^\circ$
 13. $m\angle B \approx 53^\circ$ 14. $m\angle C \approx 30^\circ$
 15. $\sin 40^\circ = \frac{w}{28}$; $w \approx 18.0$ cm
 16. $\sin 28^\circ = \frac{x}{14}$; $x \approx 7.4$ cm
 17. $\cos 17^\circ = \frac{73}{y}$; $y \approx 76.3$ cm
 18. $a \approx 28^\circ$ 19. $t \approx 47^\circ$ 20. $z \approx 76^\circ$

LESSON 12.2 • Problem Solving with Right Triangles

1. Area ≈ 2 cm² 2. Area ≈ 325 ft²
 3. Area ≈ 109 in² 4. $x \approx 54.0^\circ$
 5. $y \approx 31.3^\circ$ 6. $a \approx 7.6$ in.
 7. Diameter ≈ 20.5 cm 8. $\theta \approx 45.2^\circ$
 9. $\beta \approx 28.3^\circ$ 10. About 2.0 m
 11. About 445.2 ft 12. About 22.6 ft

LESSON 12.3 • The Law of Sines

1. Area ≈ 46 cm² 2. Area ≈ 24 m² 3. Area ≈ 45 ft²
 4. $m \approx 14$ cm 5. $p \approx 17$ cm 6. $q \approx 13$ cm
 7. $m\angle B \approx 66^\circ$, $m\angle C \approx 33^\circ$
 8. $m\angle P \approx 37^\circ$, $m\angle Q \approx 95^\circ$
 9. $m\angle K \approx 81^\circ$, $m\angle M \approx 21^\circ$
 10. Second line: about 153 ft, between tethers: about 135 ft

LESSON 12.4 • The Law of Cosines

1. $t \approx 13$ cm 2. $b \approx 67$ cm
 3. $w \approx 34$ cm
 4. $m\angle A \approx 76^\circ$, $m\angle B \approx 45^\circ$, $m\angle C \approx 59^\circ$
 5. $m\angle A \approx 77^\circ$, $m\angle P \approx 66^\circ$, $m\angle S \approx 37^\circ$
 6. $m\angle S \approx 46^\circ$, $m\angle U \approx 85^\circ$, $m\angle V \approx 49^\circ$

7. About 24° 8. About 43.0 cm
 9. About 34.7 in.

LESSON 12.5 • Problem Solving with Trigonometry

1. About 2.85 mi/h; about 15°
 2. $m\angle A \approx 50.64^\circ$, $m\angle B \approx 59.70^\circ$, $m\angle C \approx 69.66^\circ$
 3. About 8.0 km from Tower 1, 5.1 km from Tower 2
 4. About 853 miles
 5. About 530 ft of fencing; about 11,656 ft²

LESSON 13.1 • The Premises of Geometry

1. a. Given
 b. Distributive property
 c. Subtraction property
 d. Addition property
 e. Division property

2. False

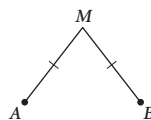

3. False

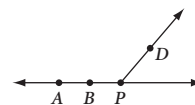

4. True; transitive property of congruence and definition of congruence

- 5.

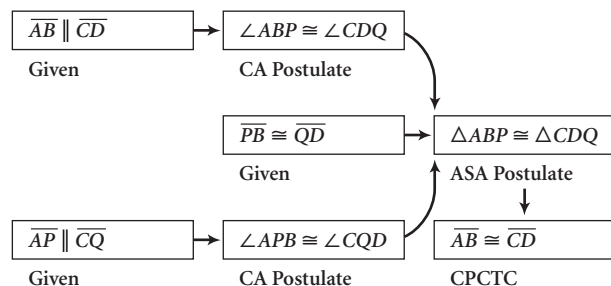

LESSON 13.2 • Planning a Geometry Proof

Proofs may vary.

1. Flowchart Proof

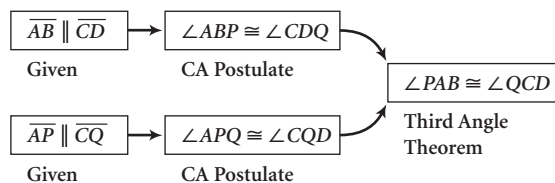

2. Flowchart Proof

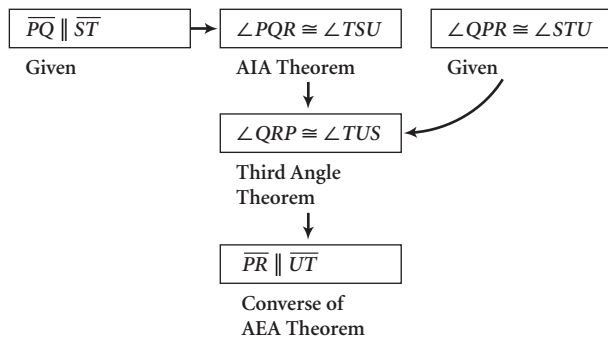

3. Flowchart Proof

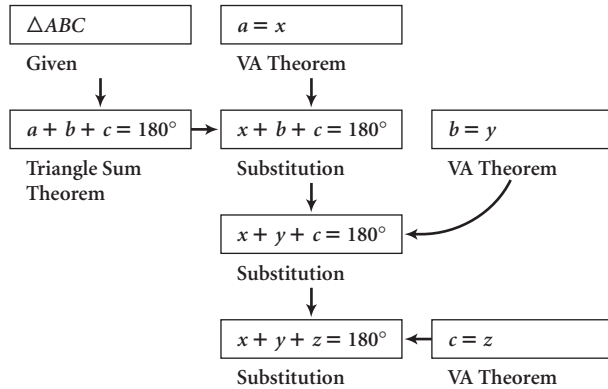

LESSON 13.3 • Triangle Proofs

Proofs may vary.

1. Flowchart Proof

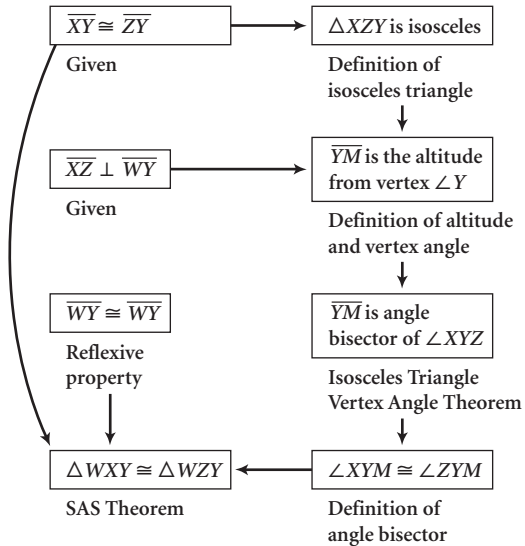

2. Proof:

Statement	Reason
1. $\overline{CD} \cong \overline{BD}$	1. Given
2. $\overline{BD} \perp \overline{AB}$	2. Given
3. $\overline{CD} \perp \overline{AC}$	3. Given
4. \overline{AD} is bisector of $\angle CAB$	4. Converse of Angle Bisector Theorem
5. $\angle CAD \cong \angle BAD$	5. Definition of angle bisector
6. $\angle ACD$ is a right angle	6. Definition of perpendicular
7. $\angle ABD$ is a right angle	7. Definition of perpendicular
8. $\angle ACD \cong \angle ABD$	8. Right Angles Are Congruent Theorem
9. $\triangle ABD \cong \triangle ACD$	9. SAA Theorem

3. Flowchart Proof

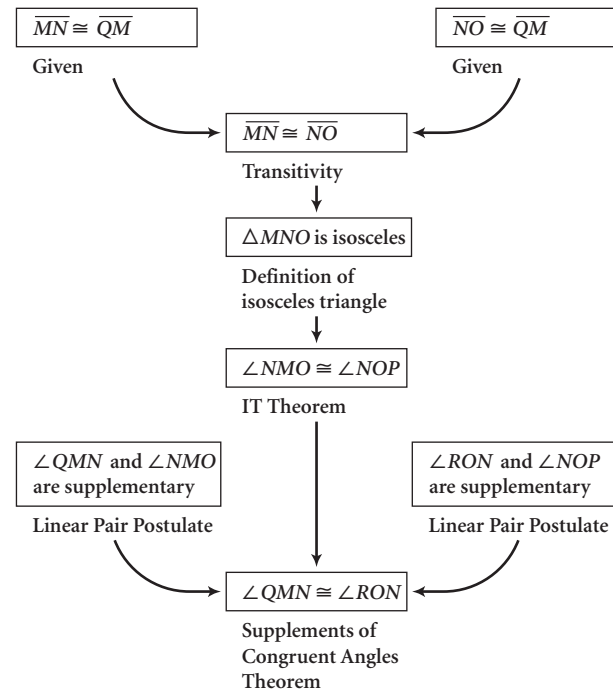

4. Proof:

Statement	Reason
1. $\overline{AB} \cong \overline{BC}$	1. Given
2. $\triangle ABC$ is isosceles	2. Definition of isosceles triangle
3. $\angle A \cong \angle ACB$	3. IT Theorem
4. $\angle ACB \cong \angle DCE$	4. Given

- 5. $\angle A \cong \angle DCE$
- 6. $\overline{AB} \parallel \overline{CE}$
- 7. $\angle ABD \cong \angle CED$
- 8. $\overline{AB} \perp \overline{BD}$
- 9. $\angle ABD$ is a right angle
- 10. $\angle CED$ is a right angle
- 11. $\overline{BD} \perp \overline{CE}$
- 3. Transitivity
- 6. Converse of CA Postulate
- 7. CA Postulate
- 8. Given
- 9. Definition of perpendicular
- 10. Definition of right angle, transitivity
- 11. Definition of perpendicular

- 3. $AM = CM$
- 4. $\overline{AM} \cong \overline{CM}$
- 5. $\angle DMA \cong \angle BMC$
- 6. $\triangle AMD \cong \triangle CMB$
- 7. $\angle DAC \cong \angle BCA$
- 8. $\overline{AD} \parallel \overline{BC}$
- 9. $\angle DMC \cong \angle BMA$
- 10. $\triangle DMC \cong \triangle BMA$
- 11. $\angle CDB \cong \angle ABD$
- 12. $\overline{DC} \parallel \overline{AB}$
- 13. $ABCD$ is a parallelogram
- 3. Given
- 4. Definition of congruence
- 5. VA Theorem
- 6. SAS Postulate
- 7. CPCTC
- 8. Converse of AIA Theorem
- 9. VA Theorem
- 10. SAS Postulate
- 11. CPCTC
- 12. Converse of AIA Theorem
- 13. Definition of parallelogram

LESSON 13.4 • Quadrilateral Proofs

Proofs may vary.

1. Given: $ABCD$ is a parallelogram

Show: \overline{AC} and \overline{BD} bisect each other at M

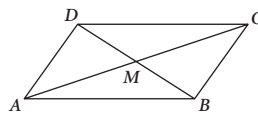

Flowchart Proof

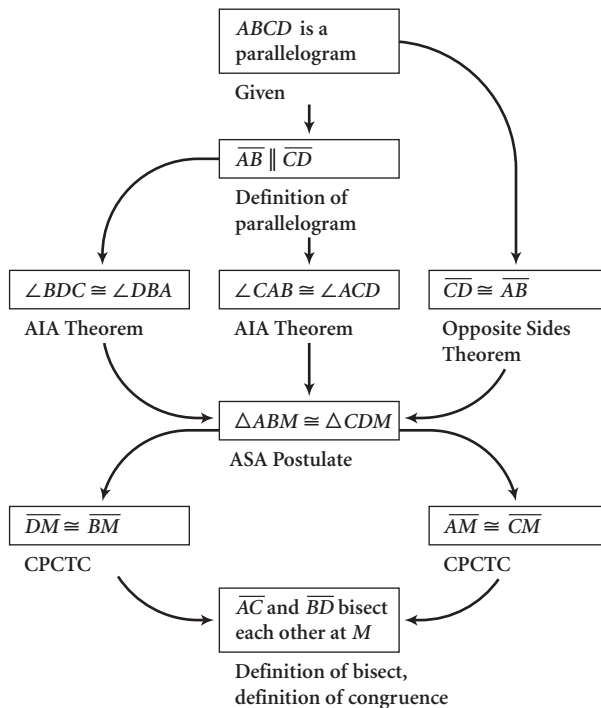

2. Given: $DM = BM$, $AM = CM$

Show: $ABCD$ is a parallelogram

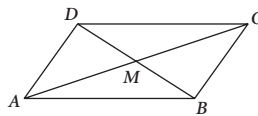

Proof:

Statement

- 1. $DM = BM$
- 2. $\overline{DM} \cong \overline{BM}$

Reason

- 1. Given
- 2. Definition of congruence

3. Given: $ABCD$ is a rhombus

Show: \overline{AC} and \overline{BD} bisect each other at M and $\overline{AC} \perp \overline{BD}$

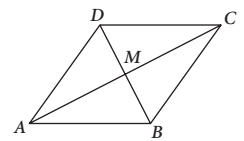

Flowchart Proof

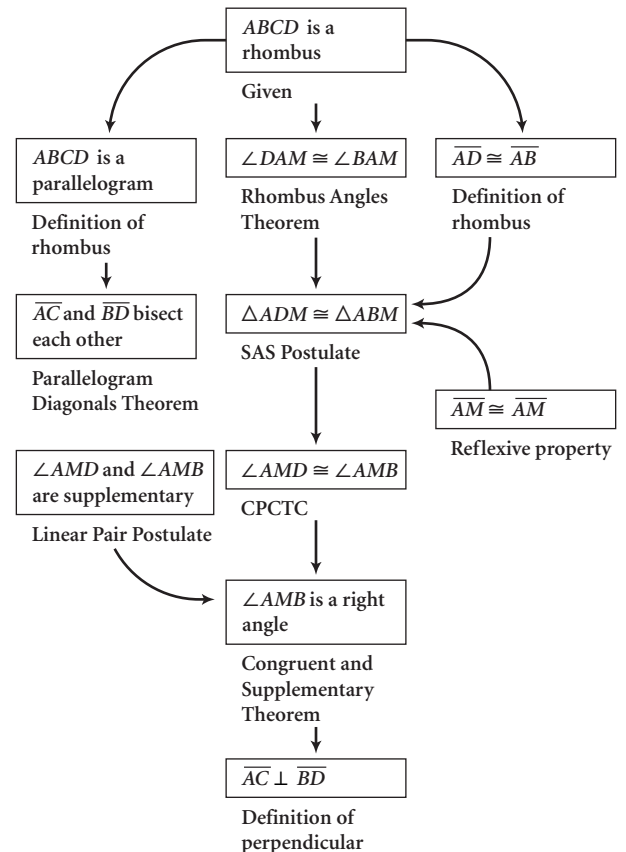

4. Given: \overline{AC} and \overline{BD} bisect each other at M and $\overline{AC} \perp \overline{BD}$

Show: $ABCD$ is a rhombus

Flowchart Proof

(See flowchart at bottom of page.)

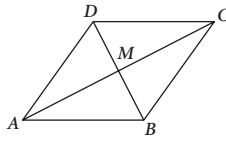

5. Given: $ABCD$ is a trapezoid with $\overline{AB} \parallel \overline{CD}$ and $\angle A \cong \angle B$

Show: $ABCD$ is isosceles

Proof:

Statement

Reason

- | | |
|---|---------------------------------------|
| 1. $ABCD$ is a trapezoid with $\overline{AB} \parallel \overline{CD}$ | 1. Given |
| 2. Construct $\overline{CE} \parallel \overline{AD}$ | 2. Parallel Postulate |
| 3. $AECD$ is a parallelogram | 3. Definition of parallelogram |
| 4. $\overline{AD} \cong \overline{CE}$ | 4. Opposite Sides Congruent Theorem |
| 5. $\angle A \cong \angle BEC$ | 5. CA Postulate |
| 6. $\angle A \cong \angle B$ | 6. Given |
| 7. $\angle BEC \cong \angle B$ | 7. Transitivity |
| 8. $\triangle ECB$ is isosceles | 8. Converse of IT Theorem |
| 9. $\overline{EC} \cong \overline{CB}$ | 9. Definition of isosceles triangle |
| 10. $\overline{AD} \cong \overline{CB}$ | 10. Transitivity |
| 11. $ABCD$ is isosceles | 11. Definition of isosceles trapezoid |

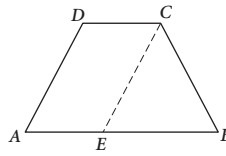

6. Given: $ABCD$ is a trapezoid with $\overline{AB} \parallel \overline{CD}$ and $\overline{AC} \cong \overline{BD}$

Show: $ABCD$ is isosceles

Proof:

Statement

Reason

- | | |
|---|---------------------------------------|
| 1. $ABCD$ is a trapezoid with $\overline{AB} \parallel \overline{CD}$ | 1. Given |
| 2. Construct $\overline{BE} \parallel \overline{AC}$ | 2. Parallel Postulate |
| 3. \overline{DC} and \overline{BE} intersect at F | 3. Line Intersection Postulate |
| 4. $ABFC$ is a parallelogram | 4. Definition of parallelogram |
| 5. $\overline{AC} \cong \overline{BF}$ | 5. Opposite Sides Congruent Theorem |
| 6. $\overline{AC} \cong \overline{BD}$ | 6. Given |
| 7. $\overline{BF} \cong \overline{BD}$ | 7. Transitivity |
| 8. $\triangle DFB$ is isosceles | 8. Definition of isosceles triangle |
| 9. $\angle DFB \cong \angle FDB$ | 9. IT Theorem |
| 10. $\angle CAB \cong \angle DFB$ | 10. Opposite Angles Theorem |
| 11. $\angle FDB \cong \angle DBA$ | 11. AIA Theorem |
| 12. $\angle CAB \cong \angle DBA$ | 12. Transitivity |
| 13. $\overline{AB} \cong \overline{AB}$ | 13. Reflexive property |
| 14. $\triangle ACB \cong \triangle BDA$ | 14. SAS Postulate |
| 15. $\overline{AD} \cong \overline{BC}$ | 15. CPCTC |
| 16. $ABCD$ is isosceles | 16. Definition of isosceles trapezoid |

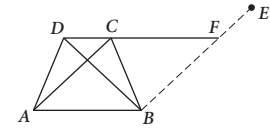

Lesson 13.4, Exercise 4

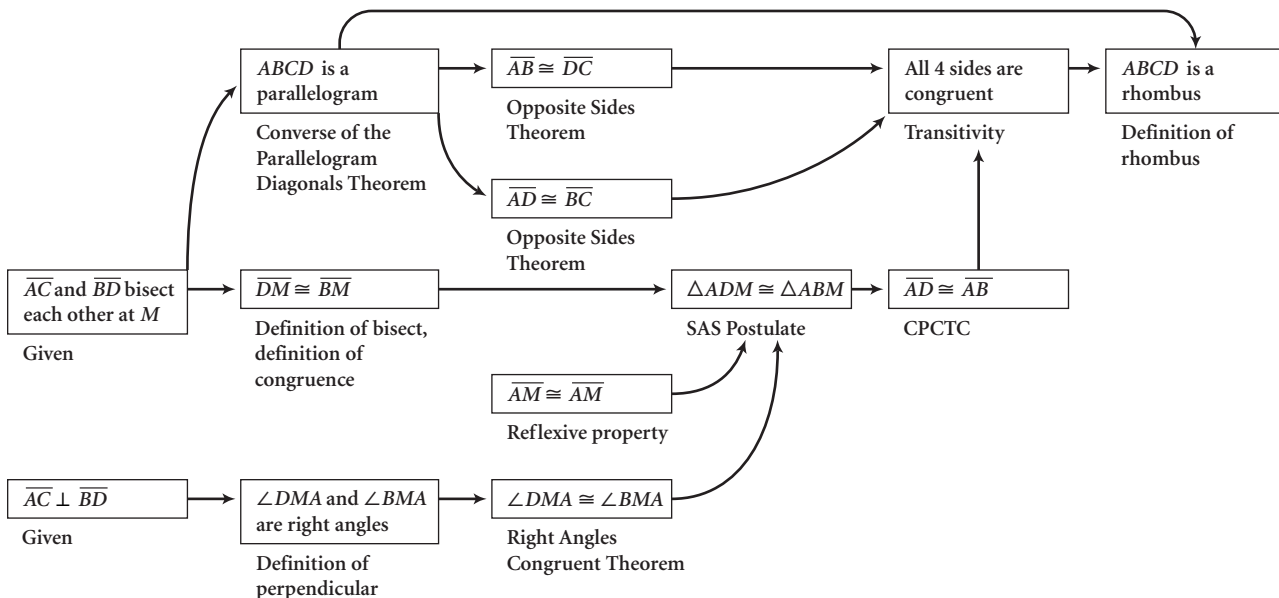

7. False

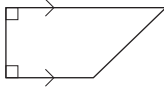

8. False

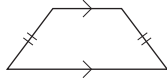

9. True

Given: $ABCD$ with $\overline{AB} \parallel \overline{CD}$ and $\angle A \cong \angle C$

Show: $ABCD$ is a parallelogram

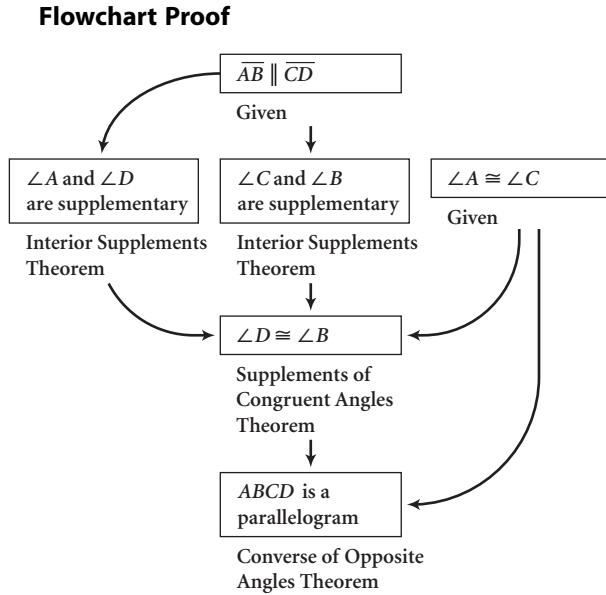
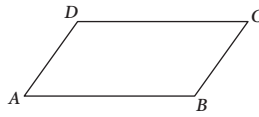

LESSON 13.5 • Indirect Proof

Proofs may vary.

1. Assume $BC \leq AC$

Case 1: If $BC = AC$, then $\triangle ABC$ is isosceles, by the definition of isosceles. By the IT Theorem, $\angle A \cong \angle B$, which contradicts the given that $m\angle A > m\angle B$. So, $BC \neq AC$.

Case 2: $\triangle DBC$ is isosceles.

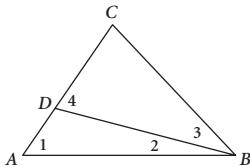

By the Exterior Angle Theorem, $m\angle 1 + m\angle 2 = m\angle 4$, so $m\angle 1 < m\angle 4$.

By the Angle Sum Postulate, $m\angle 2 + m\angle 3 = m\angle ABC$, so $m\angle 3 < m\angle ABC$. But $\triangle DBC$ is isosceles, so $m\angle 4 = m\angle 3$ by the IT Theorem.

So, by transitivity, $m\angle 1 < m\angle 4 = m\angle 3 < m\angle ABC$, or $m\angle 1 < m\angle ABC$, which contradicts the given that $m\angle A > m\angle B$. So, $BC \not\leq AC$.

Therefore the assumption, $BC \leq AC$, is false, so $BC > AC$.

2. **Paragraph Proof:** Assume $\angle DAC \cong \angle BAC$

It is given that $\overline{AD} \cong \overline{AB}$. By the reflexive property $\overline{AC} \cong \overline{AC}$. So by SAS, $\triangle ADC \cong \triangle ABC$. Then $\overline{DC} \cong \overline{BC}$ by CPCTC. But this contradicts the given that $\overline{DC} \neq \overline{BC}$. So $\angle DAC \neq \angle BAC$.

3. **Given:** $\triangle ABC$ with $\overline{AB} \neq \overline{BC}$

Show: $\angle C \neq \angle A$

Paragraph Proof: Assume $\angle C \cong \angle A$

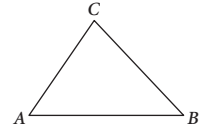

If $\angle C \cong \angle A$, then by the Converse of the IT Theorem, $\triangle ABC$ is isosceles and $\overline{AB} \cong \overline{BC}$. But this contradicts the given that $\overline{AB} \neq \overline{BC}$. Therefore, $\angle C \neq \angle A$.

4. **Given:** Coplanar lines k, ℓ , and $m, k \parallel \ell$, and m intersecting k

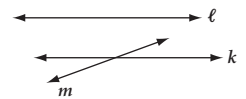

Show: m intersects ℓ

Paragraph Proof: Assume m does not intersect ℓ

If m does not intersect ℓ , then by the definition of parallel, $m \parallel \ell$. But because $k \parallel \ell$, by the Parallel Transitivity Theorem, $k \parallel m$. This contradicts the given that m intersects k . Therefore, m intersects ℓ .

LESSON 13.6 • Circle Proofs

1. **Given:** Circle O with $\overline{AB} \cong \overline{CD}$

Show: $\widehat{AB} \cong \widehat{CD}$

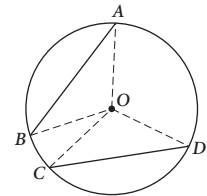

Flowchart Proof

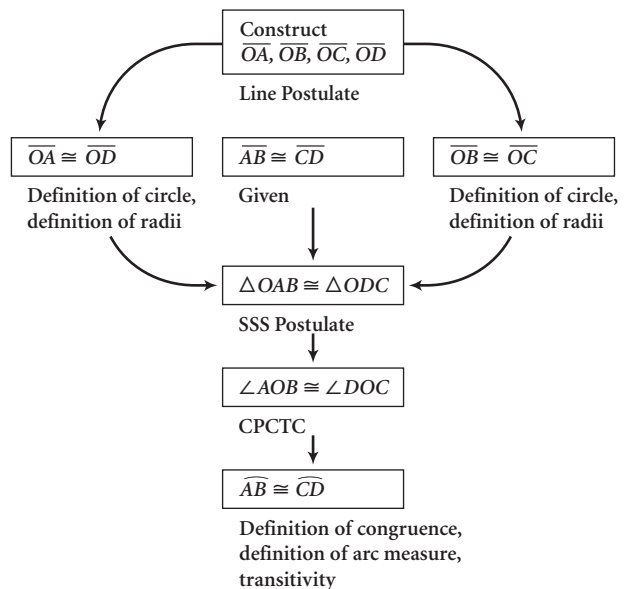

2. Paragraph Proof: Chords \overline{BC} , \overline{CD} , and \overline{DE} are congruent because the pentagon is regular. By the proof in Exercise 1, the arcs \widehat{BC} , \widehat{CD} , and \widehat{DE} are congruent and therefore have the same measure. $m\angle EAD = \frac{1}{2}m\widehat{DE}$ by the Inscribed Angles Intercepting Arcs Theorem. Similarly, $m\angle DAC = \frac{1}{2}m\widehat{DC}$ and $m\angle BAC = \frac{1}{2}m\widehat{BC}$. By transitivity and algebra, the three angles have the same measure. So, by the definition of trisect, the diagonals trisect $\angle BAE$.

3. Paragraph Proof: Construct the common internal tangent \overline{RU} (Line Postulate, definition of tangent). Label the intersection of the tangent and \overline{TS} as U .

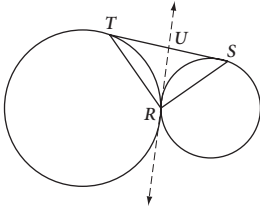

$\overline{TU} \cong \overline{RU} \cong \overline{SU}$ by the Tangent Segments Theorem. $\triangle TUR$ is isosceles by definition because $\overline{TU} \cong \overline{RU}$. So, by the IT Theorem, $\angle T \cong \angle TRU$. Call this angle measure x . $\triangle SUR$ is isosceles because $\overline{RU} \cong \overline{SU}$, and by the IT Theorem, $\angle S \cong \angle URS$. Call this angle measure y . The angle measures of $\triangle TRS$ are then x , y , and $(x + y)$. By the Triangle Sum Theorem, $x + y + (x + y) = 180^\circ$. By algebra (combining like terms and dividing by 2), $x + y = 90^\circ$. But $m\angle TRS = x + y$, so by transitivity and the definition of right angle, $\angle TRS$ is a right angle.

4. Paragraph Proof: Construct tangent \overline{TP} (Line Postulate, definition of tangent). $\angle PTD$ and $\angle TAC$ both have the same intercepted arc, \widehat{TC} . Similarly, $\angle PTD$ and $\angle TBD$ have the same intercepted arc, \widehat{TD} . So, by transitivity, the Inscribed Angles Intercepting Arcs Theorem, and algebra, $\angle TAC$ and $\angle TBD$ are congruent. Therefore, by the Converse of the CA Postulate, $\overline{AC} \parallel \overline{BD}$.

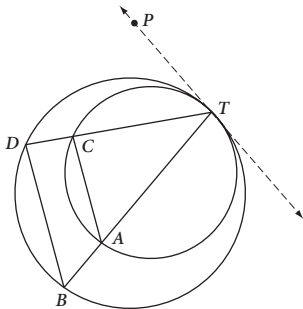

1. Flowchart Proof

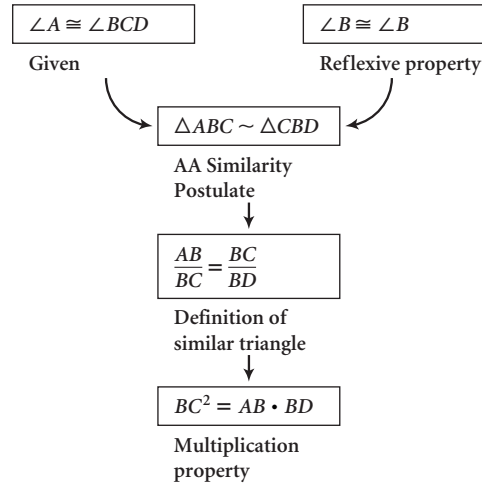

2. Given: Trapezoid $ABCD$ with $\overline{AB} \parallel \overline{CD}$, and \overline{AC} and \overline{BD} intersecting at E
Show: $\frac{DE}{BE} = \frac{CE}{AE} = \frac{DC}{AB}$

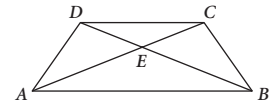

Flowchart Proof

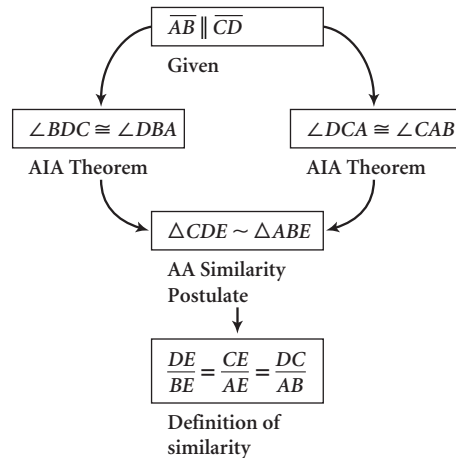

3. Given: $\triangle ABC$ with $\angle ACB$ right, $\overline{CD} \perp \overline{AB}$

Show: $AC \cdot BC = AB \cdot CD$

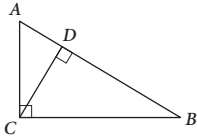

Flowchart Proof

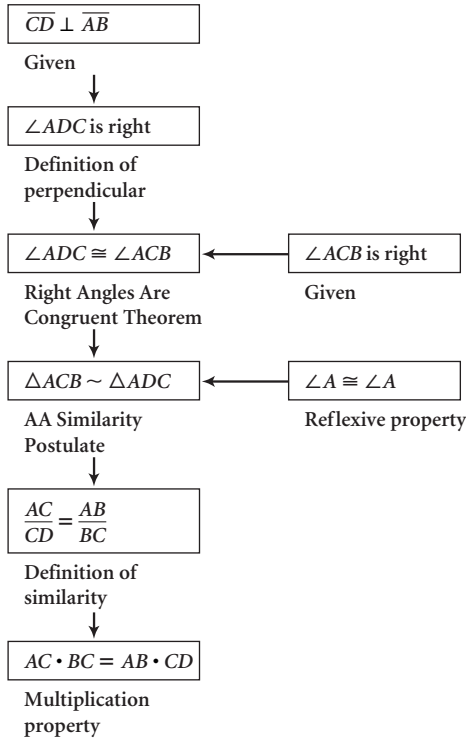

4. Given: $ABCD$ with right angles A and C , $\overline{AB} \cong \overline{DC}$

Show: $ABCD$ is a rectangle

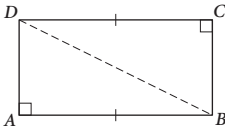

Proof:

Statement	Reason
1. Construct \overline{DB}	1. Line Postulate
2. $\angle A$ and $\angle C$ are right angles	2. Given
3. $\angle A \cong \angle C$	3. Right Angles Are Congruent Theorem
4. $\overline{AB} \cong \overline{DC}$	4. Given
5. $\overline{DB} \cong \overline{DB}$	5. Reflexive property
6. $\triangle DBA \cong \triangle BDC$	6. HL Congruence Theorem
7. $\angle DBA \cong \angle BDC$	7. CPCTC
8. $m\angle DBA = m\angle BDC$	8. Definition of congruence
9. $m\angle ADB + m\angle DBA + m\angle A = 180^\circ$	9. Triangle Sum Theorem
10. $m\angle A = 90^\circ$	10. Definition of right angle
11. $m\angle ADB + m\angle DBA = 90^\circ$	11. Subtraction property
12. $m\angle ADB + m\angle BDC = 90^\circ$	12. Substitution
13. $m\angle ADB + m\angle BDC = m\angle ADC$	13. Angle Addition Postulate
14. $m\angle ADC = 90^\circ$	14. Transitivity
15. $m\angle C = 90^\circ$	15. Definition of right angle
16. $m\angle A + m\angle ABC + m\angle C + m\angle ADC = 360^\circ$	16. Quadrilateral Sum Theorem
17. $m\angle ABC = 90^\circ$	17. Substitution property and subtraction property
18. $\angle A \cong \angle ABC \cong \angle C \cong \angle ADC$	18. Definition of congruence
19. $ABCD$ is a rectangle	19. Four Congruent Angles Rectangle Theorem

