

PRECAST
CONCRETE
TRAFFIC
BARRIERS

OUTLINE

- Purpose of Traffic Barrier
- Specifications
- NCHRP 350 & Requirements
- Types of Precast Concrete Barriers
- Precast Advantage & Cost Savings
- Quality Considerations



PURPOSE of TRAFFIC BARRIER

- Reduce the risk of an out-of-control vehicle crossing the median and colliding with opposing traffic or roadway workers.



PURPOSE of TRAFFIC BARRIER

- Reduce the risk of a vehicle deflecting back into the traffic stream after colliding with the barrier.



PURPOSE of TRAFFIC BARRIER

- Decelerate the errant vehicle within tolerable limits.
- Directing traffic in a prescribed manner.



PURPOSE of TRAFFIC BARRIER

- **Security Devices**

Protection against unwanted vehicular traffic and terrorist activities around government buildings, utility facilities, historic landmarks and airports.



APPLICABLE STANDARDS

- ASTM C 825 –
Standard
Specification for
Precast Concrete
Barriers
- NCHRP 350 –
Recommended
Procedures for the
Safety Performance
Evaluation of
Highway Features



ASTM C 825

- **Classification of Barrier**

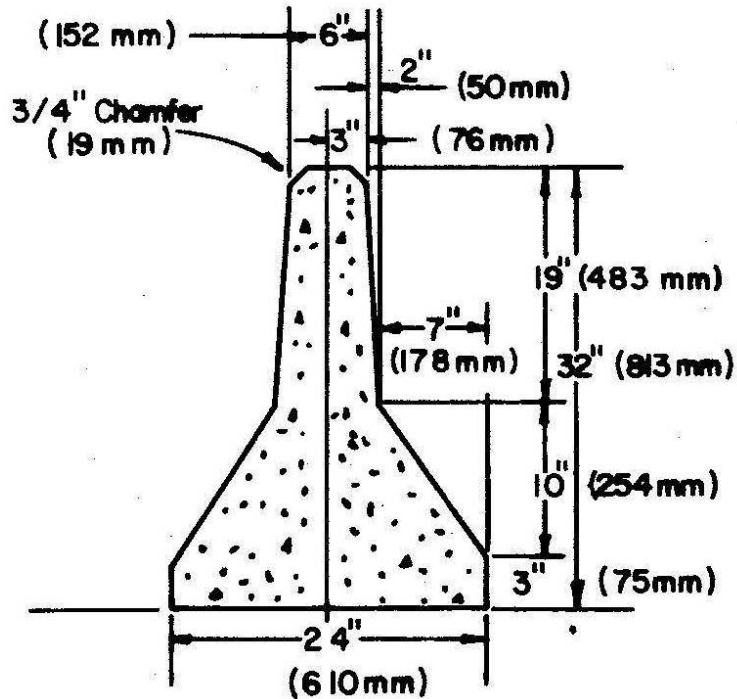

FIG. 1 New Jersey Barrier

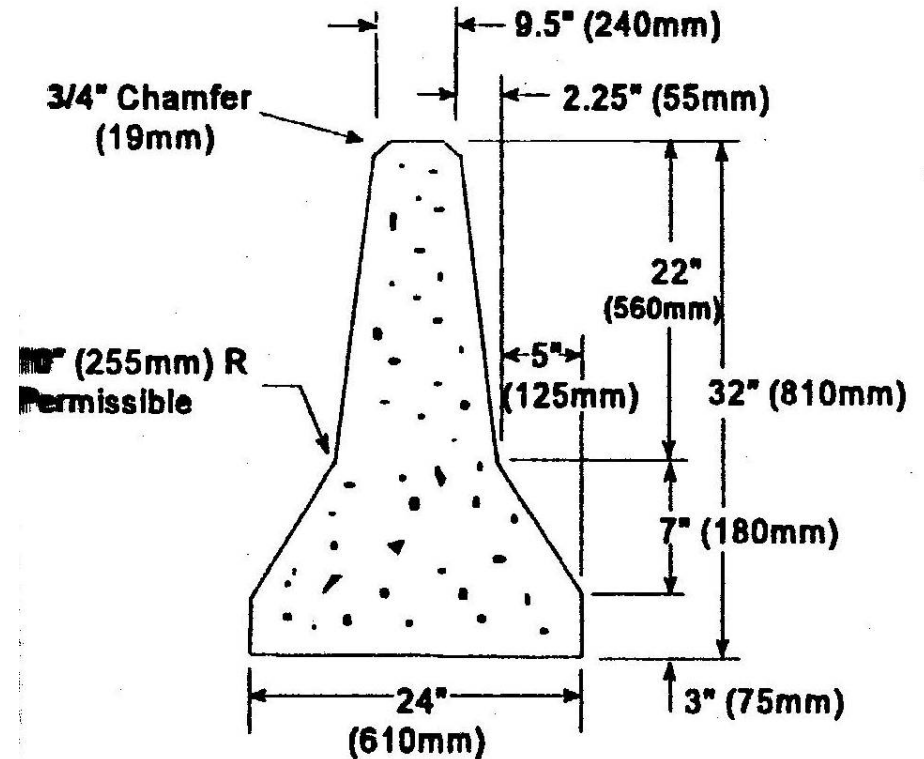

FIG. 2 Type-F Barrier

New Jersey Barrier

Type-F Barrier

ASTM C 825

- **Basis of Acceptance**

Strength Properties – Cylinders tested in accordance with ASTM C39. Average f'_c values for daily testing equal to or greater than the specified design strength.

Dimensional Properties – Cross-sectional & longitudinal dimensions, and Location & positioning of anchoring devices and reinforcement.

End Result – Acceptable to the purchaser at the point of delivery.

ASTM C 825

- **Materials**

Cement, aggregates, admixtures and steel reinforcement shall conform to applicable ASTM Specifications.

- **Manufacture**

Concrete mixture shall be proportioned and mixed to meet the minimum strength level and cured per the methods outlined in Section 7 of the ASTM C 825 specification.

- **Forms**

Sufficiently rigid to maintain dimensional parameters. All casting surfaces shall be of smooth, nonporous materials.

ASTM C 825

- **Design**

- Concrete Design Strength – 4,000 psi in 28 days
- Air Entrainment – Unless otherwise specified, all concrete will have an air content of $5 \frac{1}{2} \pm 1\%$ as measured by ASTM test method C 173 or C 231.
- Dimensions – Unless otherwise specified, the minimum length of each barrier section will be 10 feet. It is common for DOTs to ask for lengths of 20 feet or even 30 feet.

ASTM C 825

- **Design**

- Steel Reinforcement – Unless designated by the purchaser, reinforcement shall be designed by the producer and be sufficient to permit handling, delivery and placement of sections without damage.
 - Minimum concrete cover is 2.0 inches, except for end sections where cover may be less. See applicable project or ASTM specifications for specific details.
 - Shall be assembled as a cage with sufficient mat and bar to maintain shape during casting.

ASTM C 825

- **Design**

- Reinforcement design for the ends of barrier sections should be in accordance with the publication “Concrete Median Barrier Research,” Volume 2, Research Report, prepared by the Southwest Research Institute for the FHWA, to prevent fracture at the joints.
- Laps, welds and splicing shall be acceptable to the purchaser and develop full strength of reinforcement.

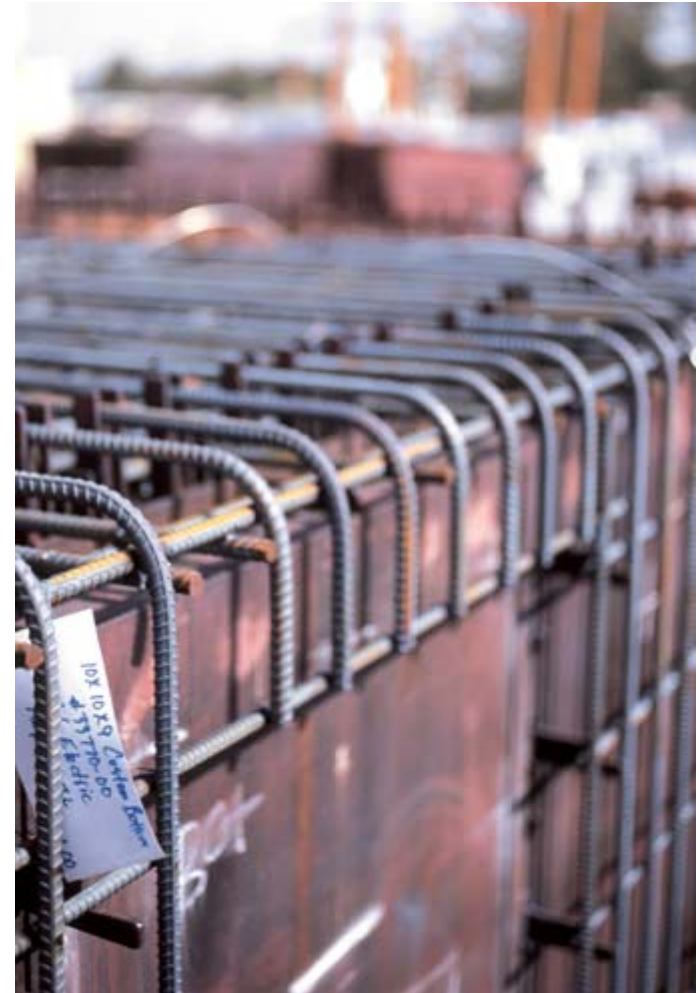

ASTM C 825

- **Design**

- Concrete Finishing – Shall be at the option of the producer, produce a finish comparable to the steel form finish and be uniform for all sections in the contract lot.
- Lifting Devices – Shall not be cast into the side surfaces of the barrier product.
- Anchorage to prevent lateral movement of the barrier shall consist of dowels, keyway joints or interlocking devices as may be specified by the purchaser.

ASTM C 825

- **Physical Requirements**

- Compression Testing – Identified with Barrier Sections
 - 2 cylinders for each 25 yd³, or a minimum of 2 cylinders per day's production in accordance with ASTM C31, "Standard Practice for Making and Curing Concrete Test Specimens in the Field," except when otherwise specified.
 - Compressive Strength per ASTM C39, "Compressive Strength of Cylindrical Specimens."

ASTM C 825

- **Permissible Dimensional Tolerances**
 - Cross-sectional dimensions shall not vary from design by more than $\frac{1}{4}$ inch. Vertical centerline shall not be out of plumb by more than $\frac{1}{4}$ inch.
 - Longitudinal dimensions shall not vary from design by more than $\frac{1}{4}$ inch in 10 feet of barrier section and not exceed $\frac{3}{4}$ inch per section.
 - Location of anchoring is specified by purchaser.

NCHRP 350

- **Summary**

- Federal Highway Administration (FHWA) issued a guidance memo in July 1997 requiring crash testing of all work zone devices on the National Highway System. This crash testing is outlined in NCHRP 350 (National Cooperative of Highway Research Programs).
- Visit the Web site at http://safety.fhwa.dot.gov/roadway_dept/road_hardware/nchrp_350.htm

NCHRP 350



- Work zone devices are subdivided into four categories.
- Precast concrete barrier falls in Category 3.

NCHRP 350

- **Crash Testing Levels**

- There are six levels for impact performance evaluation of various safety features based upon principal performance factors:
 - Structural adequacy
 - Occupant risk
 - Post-impact behavior of vehicle



NCHRP 350

- **Crash Testing Levels**

- Test Level 1 – Low-volume, low-speed local streets and highways, and some work zones
- Test Level 2 – Most local and collector roads and many work zones
- Test Level 3 – Wide range of high-speed arterial highways
- Test Levels 4-6 – Based upon volume of truck and heavy vehicle traffic and/or the consequences of penetration beyond the barrier

NCHRP 350

- Crash Testing Levels

Test Level	Barrier Section	Test Designation	Impact Conditions*			Impact Point	Evaluation Criteria* (See Table 5.1)
			Vehicle	Nominal Speed (km/h)	Nominal Angle, θ (deg)		
1	Length of Need	1-10 S1-10'	820C 700C	50 50	20 20	(b) (b)	A,D,F,H,I,(J),K,M A,D,F,H,I,(J),K,M
		1-11 S1-20' S1-21	2000P	50 50	25 25	(b) (b)	A,D,F,K,L,M A,D,F,K,L,M
2	Length of Need	2-10 S2-10'	820C 700C	70 70	20 20	(b) (b)	A,D,F,H,I,(J),K,M A,D,F,H,I,(J),K,M
		2-11 S2-20' S2-21	2000P	70 70	25 25	(b) (b)	A,D,F,K,L,M A,D,F,K,L,M
3 Basic Level	Length of Need	3-10 S3-10'	820C 700C	100 100	20 20	(b) (b)	A,D,F,H,I,(J),K,M A,D,F,H,I,(J),K,M
		3-11 S3-20' S3-21	2000P	100 100	25 25	(b) (b)	A,D,F,K,L,M A,D,F,K,L,M
4	Length of Need	4-10 S4-10'	820C 700C	100 150	20 20	(b) (b)	A,D,F,H,I,(J),K,M A,D,F,H,I,(J),K,M
		4-11* S4-20' S4-21	2000P 800DS	100 80	25 15	(b) (b)	A,D,F,K,L,M A,D,G,K,M
5	Length of Need	5-10 S5-10'	820C 700C	100 100	20 20	(b) (b)	A,D,F,H,I,(J),K,M A,D,F,H,I,(J),K,M
		5-11* S5-20' S5-21	2000P 35000V	100 80	25 15	(b) (b)	A,D,F,K,L,M A,D,G,K,M
6	Length of Need	6-10 S6-10'	820C 700C	100 100	20 20	(b) (b)	A,D,F,H,I,(J),K,M A,D,F,H,I,(J),K,M
		6-11* S6-20' S6-21	2000P 36000V	100 80	25 15	(b) (b)	A,D,F,K,L,M A,D,G,K,M

TYPES OF PRECAST BARRIERS

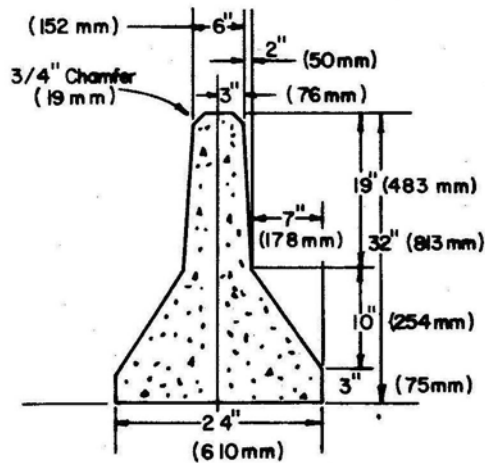

FIG. 1 New Jersey Barrier

New Jersey Barrier

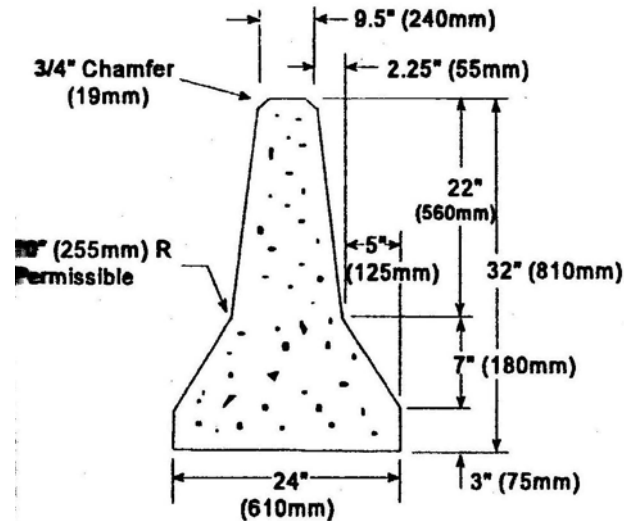
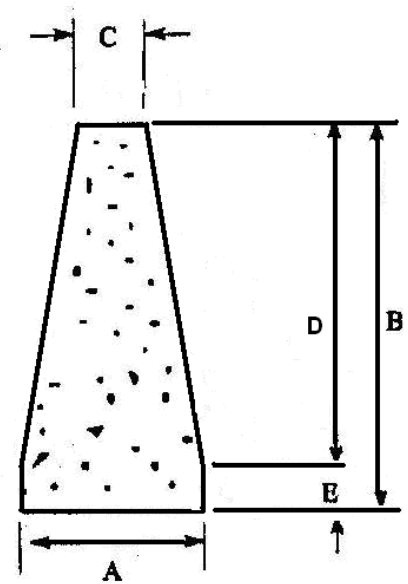

FIG. 2 Type-F Barrier

F-Shape Barrier



Safety Shape Barrier

(Constant Slope)

PRECAST ADVANTAGE

- Readily available
- Produced in a quality-controlled environment
- Durability from the elements
- Mass
- Modularity
- Faster and safer than slip-forming

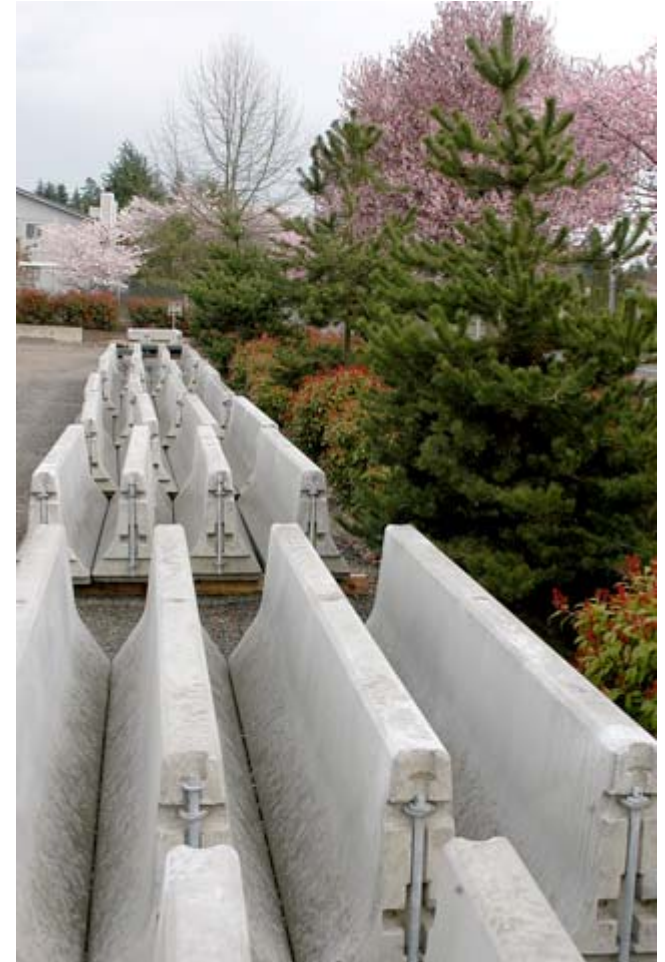

PRECAST ADVANTAGE

- Durability upon vehicular impact (unlike other types of barrier that contain sand or water and be compromised when impacted)
- Less Maintenance
- Superior Strength

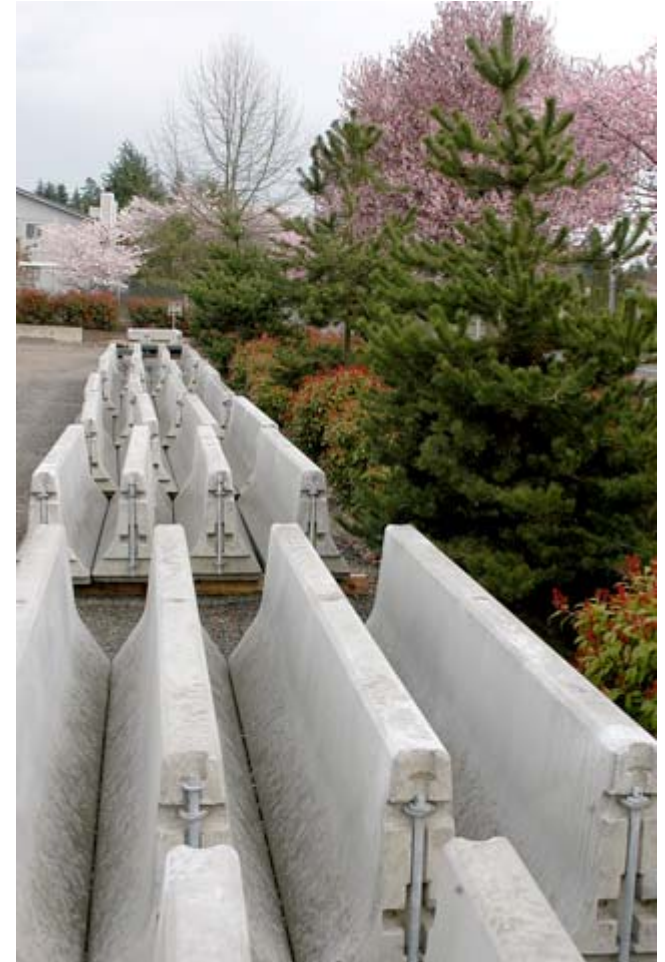

PRECAST ADVANTAGE

- **Cost Savings**

- Alternative types of barrier are sacrificial and must be replaced when an impact occurs.
- Even low-energy impacts can bend and damage steel rails and displace posts so that the barrier may not perform properly in a subsequent impact.
- Maintenance crews must spend considerable time maintaining these systems, resulting in high costs and safety risks to motorists and highway workers.

QUALITY

- **NPCA Quality Control Manual for Precast Plants, Fifth Edition**

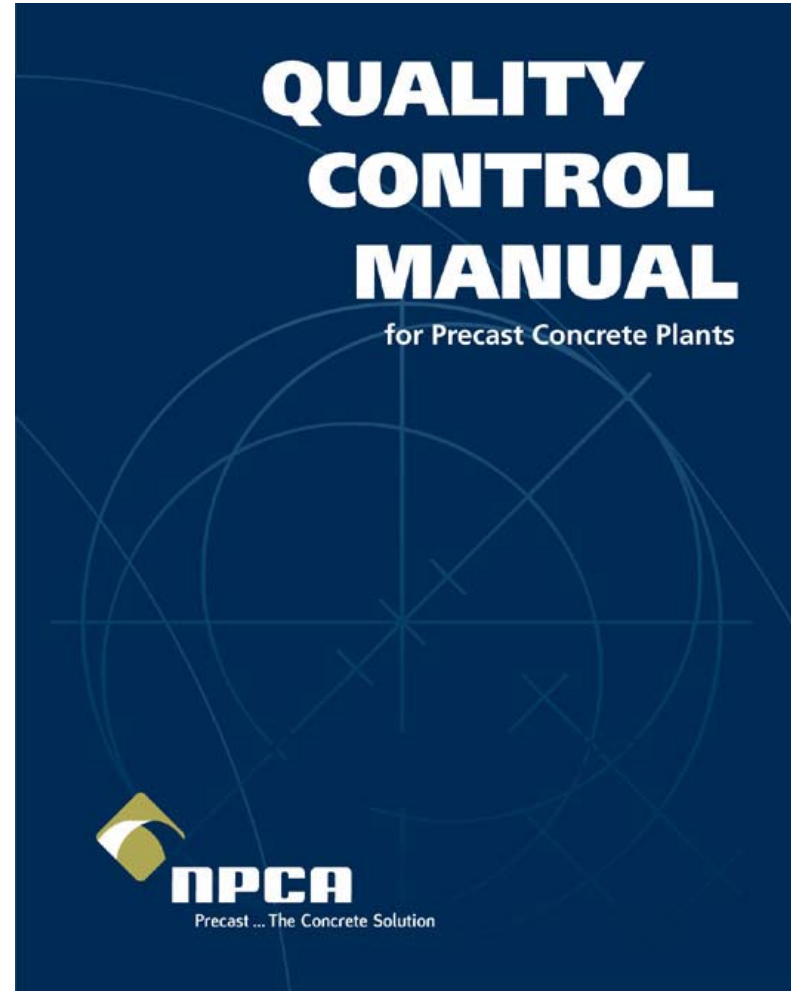

QUALITY

- **NPCA Plant Certification Program**

