

**NOW AVAILABLE!**

[www.predatoraxle.com](http://www.predatoraxle.com)

**Predator**  
Front Axles by Quality Gear



**TOUGHER. STRONGER. BETTER.**



## **Experience the Benefits of the New Predator Front Axles from Quality Gear!**

**PRECISION MANUFACTURED FROM 4340 CHROMOLY ALLOY**

**DOUBLE INDUCTION HARDENED**

**EXTREME TENSILE STRENGTH**

**39% STRONGER THAN STOCK AXLES**

**LIMITED LIFETIME WARRANTY**

**TOUGHER.  
STRONGER.  
BETTER.**



[www.PREDATORAXLE.com](http://www.PREDATORAXLE.com) [www.QUALITYGEAR.com](http://www.QUALITYGEAR.com)

# Predator Axle Conversion Kits

Complete Inner & Outer Axle Shafts with U-Joints for Both Sides



Year	Vehicle	Model	Outer Spline	Inner Spline	Conversion Axle Set	Predator RH Axle Shaft	Length	Predator LH Axle Shaft	Length
1972-81	Jeep CJ Early	D30	1.16" - 27	1.16" - 27	302700-ECJSET-QG	302700-ECJR-QG	22.86	302700-ECJL-QG	35.73
1982-86	Jeep CJ Late	D30	1.16" - 27	1.16" - 27	302700-LCJSET-QG	302700-LCJR-QG	24.54	302700-LCJL-QG	37.41
1997-Up	Jeep TJ Non Disconnect	D30	1.16" - 27	1.16" - 27	302700-JJSET-QG †	302700-JJR-QG	22.68	302700-JJL-QG †	38.51
1986-96	Jeep YJ Non Disconnect								
1985-01	Jeep XJ w/o ABS Non Disconnect								
1987-01	Jeep XJ w/ ABS Non Disconnect								
1997-Up	Jeep TJ Non Disconnect*	D30	1.31" - 30	1.31" - 30	303000-JJSET-QG	303000-JJR-QG	22.68	303000-JJL-QG	38.51
1986-96	Jeep YJ Non Disconnect*								
1985-01	Jeep XJ w/o ABS Disconnect*								
1987-01	Jeep XJ w/ ABS Non Disconnect*								
2003-Up	Jeep Rubicon	D44	1.16" - 27	1.31" - 30	443000-JRSET-QG	443000-JRR-QG	37.96	443000-JRL-QG	23.04
1980-86	Wagoneer Non-Disconnect	D44	1.25" - 19	1.31" - 30	443019-JWSET-QG	443019-JWR-QG	42.06	443019-JWL-QG	25.74
1985-92	Grande Wagoneer Non-Disconnect								
1968-79	Ford F150	D44	1.25" - 19	1.31" - 30	443019-FFSET-QG †	443019-FFR-QG †	43.63	443019-FFL-QG	28.63
1978-79	Ford Bronco (Full Size)								
1971-77	Ford Bronco	D44	1.25" - 19	1.31" - 30	443019-FBSET-QG	443019-FBR-QG	37.66	443019-FBL-QG	28.03
1972-78	GMC Truck	D44	1.25" - 19	1.31" - 30	443019-GMSET-QG	443019-GMR-QG	46.07	443019-GML-QG	28.25
1972-78	Blazer								

\* Big spline kit requires additional aftermarket locker † Coming Soon



# Predator Axle Sets

Complete Inner & Outer Axle Shafts with U-Joints for either LH or RH Sides



Year	Vehicle	Model	Side	Axle Assembly		Outer Stub Axle			Inner Axle Shaft			U-Joint
				Complete Assembly	Overall Length	Yoke Shaft	Length	Spline	Yoke Shaft	Length	Spline	
				Predator #	A	Predator #	C	B	Predator #	E	D	
1972-81	Jeep CJ Early	D30	RH	302700-ECJR-QG	22.86	39105QG	8.72	1.16" - 27	38803QG	14.14	1.16" - 27	5-760QG
1972-81	Jeep CJ Early	D30	LH	302700-ECJL-QG	35.73	39105QG	8.72	1.16" - 27	38789QG	27.01	1.16" - 27	5-760QG
1982-86	Jeep CJ Late	D30	RH	302700-LCJR-QG	24.54	39105QG	8.72	1.16" - 27	38805QG	15.82	1.16" - 27	5-760QG
1982-86	Jeep CJ Late	D30	LH	302700-LCJL-QG	37.41	39105QG	8.72	1.16" - 27	38804QG	28.69	1.16" - 27	5-760QG
1997-Up	Jeep TJ Non Disconnect	D30	RH	302700-JJR-QG	22.68	38822QG	6.11	1.16" - 27	38875-27QG	16.57	1.16" - 27	5-760QG
1986-96	Jeep YJ Non Disconnect											
1985-01	Jeep XJ w/o ABS Non Disconnect											
1987-01	Jeep XJ w/ ABS Non Disconnect											
1997-Up	Jeep TJ Non Disconnect	D30	LH	302700-JJL-QG †	38.51	38822QG	6.11	1.16" - 27	38821-27QG	32.40	1.16" - 27	5-760QG
1986-96	Jeep YJ Non Disconnect											
1985-01	Jeep XJ w/o ABS Non Disconnect											
1987-01	Jeep XJ w/ ABS Non Disconnect											
1997-Up	Jeep TJ Non Disconnect	D30	RH	303000-JJR-QG	22.68	38822QG	6.11	1.31" - 30	38875-30QG	16.57	1.31" - 30	5-760QG
1986-96	Jeep YJ Non Disconnect											
1985-01	Jeep XJ w/o ABS Non Disconnect											
1987-01	Jeep XJ w/ ABS Non Disconnect											

\* Big spline kit requires additional aftermarket locker † Coming Soon

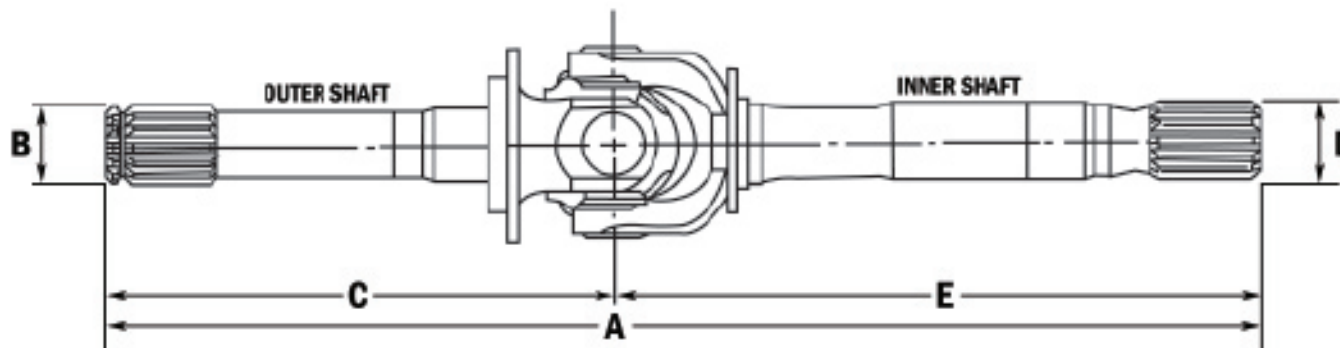

[www.PREDATORAXLE.com](http://www.PREDATORAXLE.com) [www.QUALITYGEAR.com](http://www.QUALITYGEAR.com)

# Predator Axle Sets

Complete Inner & Outer Axle Shafts with U-Joints for either LH or RH Sides



Year	Vehicle	Model	Side	Axle Assembly		Outer Stub Axle			Inner Axle Shaft			U-Joint
				Complete Assembly	Overall Length	Yoke Shaft	Length	Spline	Yoke Shaft	Length	Spline	
				Predator #	A	Predator #	C	B	Predator #	E	D	
1997-Up	Jeep TJ Non Disconnect *	D30	LH	303000-JJL-QG	38.51	38822QG	6.11	1.31" - 30	38821-30QG	32.40	1.31" - 30	5-760QG
1986-96	Jeep YJ Non Disconnect *											
1985-01	Jeep XJ w/o ABS Non Disconnect *											
1987-01	Jeep XJ w/ ABS Non Disconnect *											
* Big spline kit requires additional aftermarket locker												
2003-Up	Jeep Rubicon	D44	RH	443000-JRR-QG	37.96	38822QG	6.11	1.16" - 27	38823QG	31.85	1.31" - 30	5-760QG
2003-Up	Jeep Rubicon	D44	LH	443000-JRL-QG	23.04	38822QG	6.11	1.16" - 27	38824QG	16.93	1.31" - 30	5-760QG
1980-86	Wagoneer Non-Disconnect	D44	RH	443019-JWR-QG	25.74	38815QG	9.94	1.25" - 19	39459QG	15.80	1.31" - 30	5-760QG
1985-92	Grande Wagoneer Non-Disconnect											
1980-86	Wagoneer Non-Disconnect	D44	LH	443019-JWL-QG	42.06	38815QG	9.94	1.25" - 19	39461QG	32.12	1.31" - 30	5-760QG
1985-92	Grande Wagoneer											
1968-79	Ford F150	D44	RH	443019-FFR-QG †	43.63	38816QG	9.72	1.25" - 19	39144QG †	33.91	1.31" - 30	5-760QG
1978-79	Ford Bronco (Full Size)											
1968-79	Ford F150	D44	LH	443019-FFL-QG	28.63	38816QG	9.72	1.25" - 19	39143QG	18.91	1.31" - 30	5-760QG
1978-79	Ford Bronco (Full Size)											
1971-77	Ford Bronco	D44	RH	443019-FBR-QG	37.66	38816QG	9.72	1.25" - 19	38810QG	27.94	1.31" - 30	5-760QG
1971-77	Ford Bronco	D44	LH	443019-FBL-QG	28.03	38816QG	9.72	1.25" - 19	38809QG	18.31	1.31" - 30	5-760QG
1972-78	GMC Truck	D44	RH	443019-GMR-QG	46.07	38815QG	9.94	1.25" - 19	39529QG	36.13	1.31" - 30	5-760QG
1972-78	Blazer											
1972-78	GMC/Chev Truck	D44	LH	443019-GML-QG	28.25	38815QG	9.94	1.25" - 19	38809QG	18.31	1.31" - 30	5-760QG
1972-78	Blazer / Jimmy (Full Size)											

† Coming Soon

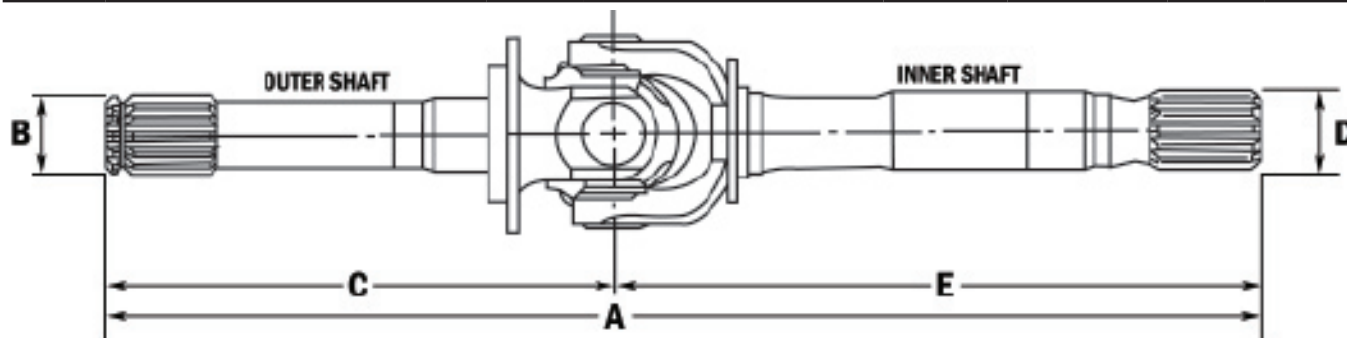

[www.PREDATORAXLE.com](http://www.PREDATORAXLE.com)  
[www.QUALITYGEAR.com](http://www.QUALITYGEAR.com)

# Predator Components

## Individual Axle Pieces



Year	Vehicle	Model	Spline	Predator #	Location	Side	Length	U-Joint
1972-81	Jeep CJ †	Dana 30	1.16-27	38789QG	Inner	LH	27.01	5-760X
1972-81	Jeep CJ	Dana 30	1.16-27	38803QG	Inner	RH	14.14	5-760X
1982-86	Jeep CJ	Dana 30	1.16-27	38804QG	Inner	LH	28.69	5-760X
1982-86	Jeep CJ	Dana 30	1.16-27	38805QG	Inner	RH	15.82	5-760X
1997-Up	Jeep TJ	Dana 30	1.16-27	38821-27QG †	Inner	LH	16.57	5-760X
1987-Up	Jeep Wrangler							
1984-90	Jeep XJ							
1997-Up	Jeep TJ *	Dana 30	1.31-30	38821-30QG	Inner	LH	16.57	5-760X
1987-Up	Jeep Wrangler *							
1984-90	Jeep XJ *							
1997-Up	Jeep TJ	Dana 30	1.16-27	38822QG	Outer	BOTH	6.11	5-760X
1987-Up	Jeep Wrangler							
1984-90	Jeep XJ							
1997-Up	Jeep TJ	Dana 30	1.16-27	38875-27QG	Inner	RH	32.40	5-760X
1987-Up	Jeep Wrangler							
1984-90	Jeep XJ							

† Coming Soon \* Big spline kit requires additional aftermarket locker



[www.PREDATORAXLE.com](http://www.PREDATORAXLE.com)    [www.QUALITYGEAR.com](http://www.QUALITYGEAR.com)



# Predator Components

## Individual Axle Pieces



Year	Vehicle	Model	Spline	Predator #	Location	Side	Length	U-Joint
1972-86	Jeep CJ	Dana 30 / Dana 44	1.16-27	39105QG	Outer	BOTH	8.72	5-760X
1972-86	Scout							
1971-77	Ford Bronco	Dana 44	1.31-30	38809QG	Inner	LH	18.31	5-760X
1969-78	GM Truck / Blazer					RH		
1971-77	Ford Bronco	Dana 44	1.31-30	38810QG	Inner	RH	27.94	5-760X
1973-87	GM Truck / Blazer	Dana 44 / GM 8.5	1.25-19	38815QG	Outer	BOTH	9.94	5-760X
1974-83	Jeep Wagoneer (Disc Brake)							
1971-79	Ford Bronco / F150	Dana 44	1.25-19	38816QG	Outer	BOTH	9.72	5-760X
1974-76	Jeep Wagoneer (Drum Brake)							
2003-Up	Jeep Wrangler, TJ & Rubicon	Dana 44	1.31-30	38823QG	Inner	RH	31.85	5-760X
2003-Up	Jeep Wrangler, TJ & Rubicon	Dana 44	1.31-30	38824QG †	Inner	LH	16.93	5-760X
1968-79	Ford Bronco / F150	Dana 44	1.31-30	39143QG	Inner	LH	18.91	5-760X
1968-79	Ford Bronco / F150	Dana 44	1.31-30	39144QG †	Inner	RH	33.91	5-760X
1980-84	Jeep Wagoneer	Dana 44	1.31-30	39459QG	Inner	RH	32.12	5-760X
1980-84	Jeep Wagoneer	Dana 44	1.31-30	39461QG	Inner	LH	15.80	5-760X
1969-78	GM Truck / Blazer	Dana 44	1.31-30	39529QG	Inner	LH	36.13	5-760X
Varies	GM	Dana 60/70 *	35	46100QG	Outer	BOTH	12.00	5-806X
1977-Up	Ford	Dana 60/70 *	35	46101QG	Outer	BOTH	11.40	5-806X

\*Dana 60 - Upgrade from 30 spline. 35 spline hubs required. † Coming Soon



[www.PREDATORAXLE.com](http://www.PREDATORAXLE.com)    [www.QUALITYGEAR.com](http://www.QUALITYGEAR.com)

## *Limited Lifetime Warranty Policy*



**Quality Gear** offers a Limited Lifetime Warranty covering manufacturing defects and axle breakage for as long as you own the vehicle. This warranty is not transferable to another party. The first warranty return will be covered by our “Don’t ask, Don’t tell” policy.

**Quality Gear** and its authorized distributors reserve the right to either replace the axle or refund the original purchase price after the first warranty claim. **Quality Gear** and its authorized distributors will make the final determination on all warranty considerations.

This warranty does not cover, and **Quality Gear** and its authorized distributors shall not be liable for, incidental or consequential damages, including loss of time, road service charges, labor charges, inconvenience, loss of revenues, or loss or damage to personal property (including loss or damage to vehicle parts due to the failure of a **Quality Gear** product).

In addition, this warranty does not cover, and **Quality Gear** and its authorized distributors will not be liable for, any undertaking, representation, or agreements made by dealers or other third parties selling **Quality Gear** products, except where such agreements are within the provisions of this Warranty statement. Also, this warranty does not cover damage to the axle caused by or facilitated by failure of any other component.



[www.PREDATORAXLE.com](http://www.PREDATORAXLE.com)



[www.QUALITYGEAR.com](http://www.QUALITYGEAR.com)