

Just the Technical Facts

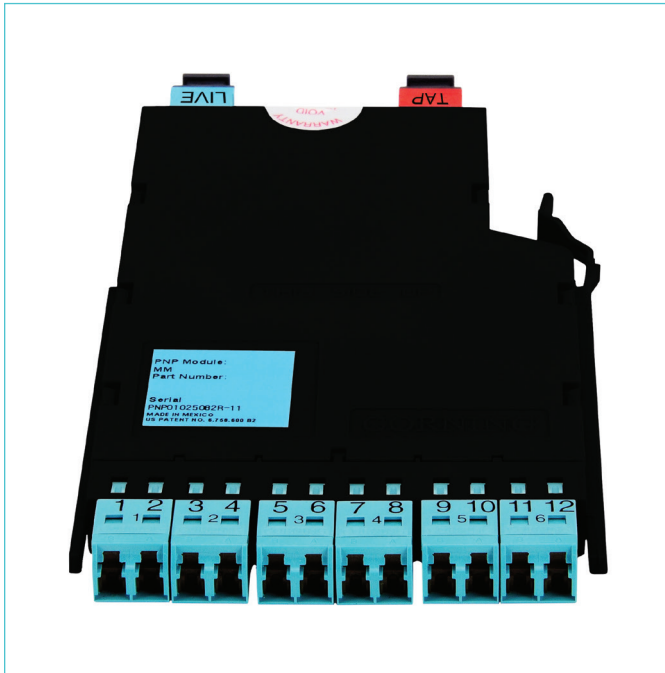

Unlike most passive tap devices, the Pretium EDGE® Tap Module is fully integrated into the structured cabling physical plant, rather than added as a separate component into the link. This integrated and advanced design improves network efficiency, increases revenue and reduces cost.

Pretium EDGE Tap Module Tapping Technology

What is port tapping?

Port tapping is a method of monitoring traffic being transmitted and received along a link in a network – this monitored traffic is then analyzed. This can be done actively via electronic devices that replicate, or mirror, the link's data and send it to a monitoring device. Or it can be done passively, with a device that simply passes through all data and sends it simultaneously to both its intended recipient and to a monitoring device. In both instances, the monitoring device filters the data and sends it to various software tools for analysis and then on to application-layer software for use by network administrators.



Just the Technical Facts

While the idea of “tapping” has obvious surveillance implications, making it desirable for analyzing potential security threats (denial of service attacks, hackers), many network administrators use port tapping to monitor the performance of their network and identify bottlenecks or other performance issues.

What does “tap” stand for?

Nothing. The word is used in the surveillance sense (a “tap” on a phone line), meaning to connect into and monitor communications that are being transmitted. Some vendors have created an acronym from the word to give it additional meaning (e.g., “Test Access Port”) but the technology and language of network tapping as a surveillance method for the network precedes these acronyms.

What’s the difference between active and passive tapping?

Active tapping, sometimes called mirroring or switch port analysis (SPAN), uses active electronics to duplicate a link’s traffic and send it to a monitoring device. An active port tap requires that one of the switch ports be utilized solely for tapping, reducing the number of ports that can be used for live network data.

Passive tapping is considered “pass through,” in that the link’s traffic is not replicated by the switch in any way – instead the optical signal’s power is divided and the data stream sent simultaneously to both live traffic and monitoring electronics. Keep in mind, some port tap devices that are called “passive” do contain electronic devices to push the pass-through data along (they are considered passive in the sense that they are not replicating data). The Pretium EDGE® Tap Module is fully passive, with no electronics or power requirements.

Ultimately, as long as you have selected the right multimode fiber for the planned data rates and distances in your data center, and barring extremely long lengths, the additional MTP® Connector pair in other Pretium EDGE Solutions will have no bearing on your optical budget. We design all Pretium EDGE Solutions components to fit within standard link-loss budgets for all network protocols in the data center/SAN.

What are the advantages of passive tapping over active mirror tapping?

There are four primary advantages that passive tapping has – whether via Pretium EDGE Solutions or other passive devices – versus mirror tapping:

- Passive taps deliver full duplex (transmit and receive) port monitoring at scalable data rates and do not require oversubscription. Mirror tapping requires a 2:1 oversubscription, as it fully replicates (duplicates) each port’s data.
- A passive tap is invisible to the network, passing all data through versus replicating it, and therefore creates no change to the timing of frame/packet interactions or extra burden on the production network, as mirror tapping does.
- Mirror tapping requires an engineer to configure the switch to recognize a port as a tapping port – if this configuration is not disabled during a network refresh, a mirror port can be cabled to serve as a network port, creating a “bridging loop” and resulting in network performance issues. Passive tapping is completely passive, a physical connection that passes data through without switch configurations or programming.
- Passive taps pass on all traffic in the link for monitoring; mirror ports may not receive corrupt data or improperly sized packets, eliminating a full picture of how the network is performing.

For details on the advantages of a fully integrated optical tap like the Pretium EDGE Tap Module over other passive tapping devices, see the Pretium EDGE Tap Module section.

Just the Technical Facts

Coupler/Splitter Technology

What is a coupler?

A coupler, also called a splitter, is a passive device that takes a single input of optical light and divides it into two or more outputs. (It can also take two or more inputs of light and combine them into a single output.) This coupling of the light can be accomplished in several ways, including fusing two or more fibers together (fused biconic taper being the most common method) so that the fiber cores are merged, or by the use of microlenses, beam splitters or other reflective or guiding devices.

What type of coupler technology does the Pretium EDGE® Tap Module use?

Corning takes advantage of an advanced coupler technology that is proprietary to one of our innovative suppliers. It results in significantly lower attenuation and more equal power distribution between the outputs than the multimode coupler technology used by today's passive taps. This improved optical performance increases link length and, in the case of Fibre Channel standards, reduces uncertainty for customers as it allows them to work within the channel link distances dictated by the standard. This is not possible today with existing devices.

Why are there different split ratios with passive taps?

The most common split ratio configurations are 70/30 (with 70 percent of the output power to the live traffic receiver and 30 percent of the output power going to the monitoring device) and 50/50. This allows flexibility for cable lengths and data rates, as well as the sensitivities of the electronics. This is largely an issue for multimode networks, as single-mode doesn't have the distance or data rate limitations of multimode (though at the expense – literally – of much higher electronics costs.)

Why was passive tapping on 8G Fibre Channel “out of standards” before the Pretium EDGE Tap Module?

Because 8G Fibre Channel is more distance limited, the higher attenuation of other passive tap devices reduces the distance for live traffic over multimode to less than 5 m on OM4 (zero meters for OM3). For nearly any real-world data center, this almost always meant that to do passive tapping, you had to go outside of the Fibre Channel standard and hope that the transceivers would still work. With the Pretium EDGE Tap Module's superior optical performance, distances up to 135 m are achievable with 8G Fibre Channel.

Why can't 8G Fibre Channel go farther than 10G Ethernet? Isn't it a lower data rate and therefore should be able to go farther?

This is a result of the transceivers used for the Fibre Channel protocol. They are designed to less stringent specifications than 10G Ethernet transceivers, so Fibre Channel's distance is more limited despite its lower data rate.

The Pretium EDGE Tap Module

What is the Pretium EDGE Tap Module?

The Pretium EDGE Tap Module is a module with fiber optic couplers inside that divide the optical signal into two outputs, one for live link traffic and one for monitoring. The live traffic continues through the system link while the monitor traffic is sent to an active monitoring device.

Unlike most passive tap devices, the Pretium EDGE Tap Module is fully integrated into the structured cabling physical plant, rather than added as a separate component into the link. Rear-exiting, MTP®-connector-based tap ports improve rack utilization and consolidation for higher revenue generation per rack unit. The Pretium EDGE Tap Module also uses the Pretium EDGE footprint for maximum density and cable management, and can be installed inside the same Pretium EDGE Hardware as a standard Pretium EDGE Module.

Just the Technical Facts

What is the advantage of integrating the passive tap into the structured cabling components?

Non-integrated passive tap devices create an additional segment in the total channel link – you must connect from your patch panel/module to the tap device and then connect from that device to your switching and monitoring electronics. When you want to make changes to your monitored ports, you must temporarily disable the link – including the live traffic – in order to make new physical connections between the ports to be monitored and the passive tap device.

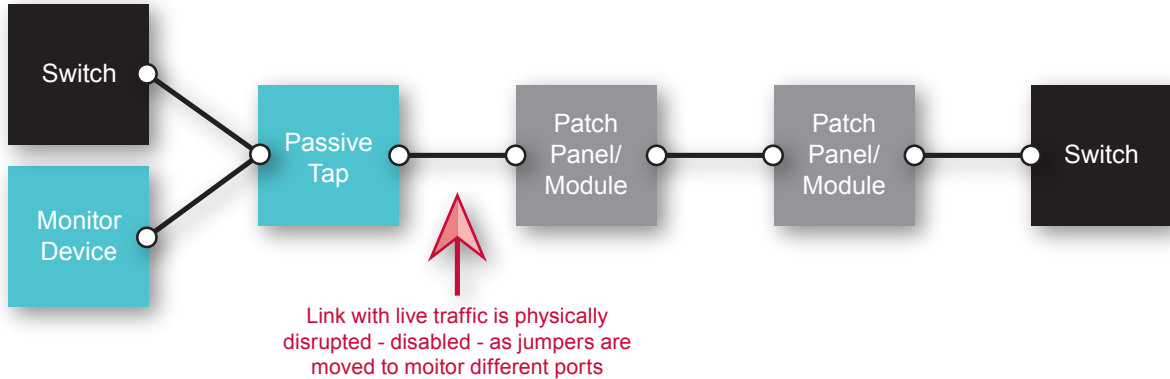

With Corning’s Pretium EDGE® Tap Module, the module serves as both the “patch panel” and the passive tap device. You can change the ports that are monitored without ever disrupting the flow of live traffic.

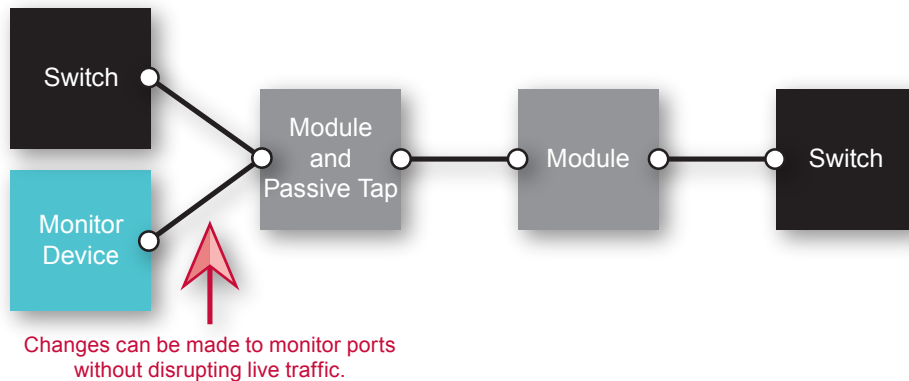

As you can see, this structured cabling solution for passive tapping also eliminates two connections (one jumper) from the link, which some network designers will find useful for their optical budgets at more extended distances.

What is the advantage of rear-exiting, MTP® Connector-based tap ports?

By placing the port for monitor traffic to the rear of the module, the Pretium EDGE Tap Module essentially creates a “zero U” solution for network monitoring, as the monitor ports use the same footprint as the live traffic and require no additional space. With other passive tap devices, the monitor port takes up space in the front of the rack that could be used for a live traffic port. In fact, the usual rule of thumb for other passive tapping devices is to add another 1U of rack space for every 8-16 ports that are tapped! With the Pretium EDGE Tap Module, you can have 72 ports of live traffic in 1U at the front of your rack and monitor all 72 ports in the same footprint by having the monitored ports exit the rear of the module! This improved rack space density means higher revenue generation per rack unit in your data center or storage area network.

Just the Technical Facts

The use of MTP® Connector-based ports in the rear of the Pretium EDGE® Tap Module also enables the use of trunks or harnesses to deliver traffic to the transceiver and monitoring electronics instead of individual LC jumpers.

LC-based, port-to-port jumper connectivity requires by near necessity that the transceiver and the monitoring electronics be located close to one another or risk a “spaghetti mess” in the cable pathway. This can result in underutilization and redundancy of monitoring equipment in the data center, as each rack may need its own monitoring electronics to support just the ports being monitored in that rack location. There is also an increased risk of patching errors because live and monitored traffic are in the same rack and may be accessed by many different personnel (network teams and data compliance/security teams).

An MTP trunk and module, or MTP harness, means you can easily consolidate all of your monitoring equipment in a separate location from your transceivers, without the “spaghetti mess” in your cable pathways and allow each piece of monitoring equipment to be fully utilized regardless of the location of the port being monitored. In addition, you can now fully segregate the monitoring electronics from the transceivers, eliminating the risk of a patching error in the monitoring cabinet creating any downtime of the live network.

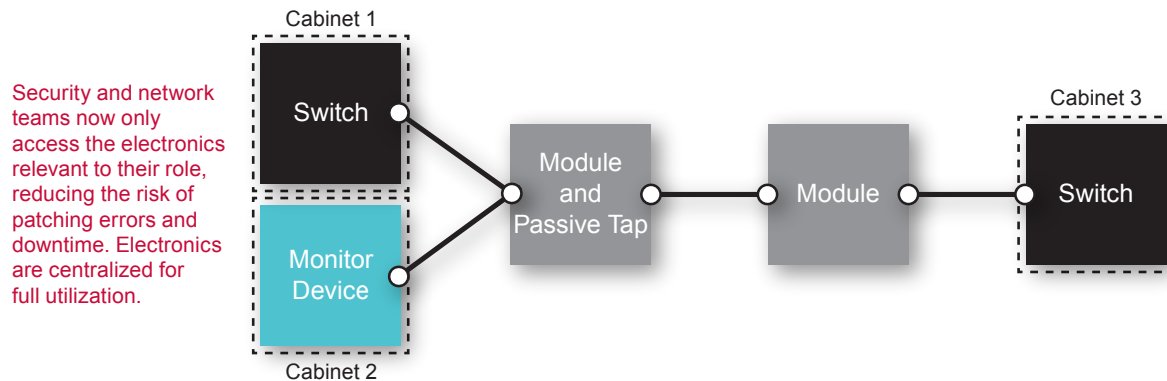

What is the density of a Pretium EDGE Tap Module and how does that compare to other passive tap devices?

The Pretium EDGE Tap Module enables 72 ports per 1U of rack space. Other passive tap devices offer 3-16 ports per 1U of rack space. Also the Pretium EDGE Tap module can be used with all Pretium EDGE housings, creating large tapping interconnect and cross-connects.

Is the Pretium EDGE Tap Module scalable to data rates higher than 8G Fibre Channel and 10G Ethernet?

At this time, no. Because of the innate limitations of transmitting ultra-high data rates over multimode fiber when you are limiting the signal’s strength by 30 to 50 percent, it is more challenging to achieve higher data rates without reducing cable distance to an impractically short degree. However, our Pretium EDGE Tap Module does offer significantly better attenuation than other devices, so we are still testing and evaluating the module’s performance at ultra-high data rates over multimode.

Are any passive tap devices scalable beyond 8G Fibre Channel and 10G Ethernet?

No, no one currently offers a passive multimode tap device that performs at data rates higher than 8G Fibre Channel or 10G Ethernet. There are some single-mode devices that have been created for 40G transmission specifically at 1310 nm. Single-mode is able to achieve much higher data rates over longer distances than multimode, but with the disadvantage of much higher electronics costs.

Just the Technical Facts

System Design

How do I factor the monitor link distance into determining my total channel link length/optical budget for the link?

There are three paths through a tap module to take into account. 1) The live network path. 2) The “near” tap path - the route from the electronics closest to the tap through to the monitoring electronics. And 3) The “far” tap path - the route from the electronics farthest from the tap to the monitoring electronics. Each path has its own budget and therefore its own distance limitations.

Does 8G Fibre Channel have to use the 70/30 split ratio or can I use a 50/50 ratio?

Theoretically, it’s possible, but it’s not practical. The transceivers for 8G Fibre Channel are less sensitive and require stronger signal strength – if a tap device with a 50/50 split ratio were used, the resulting channel link length would be at risk for failure.

Why is 8G Fibre Channel limited to 5 m distance for the monitor portion of the link?

Because only 30 percent of the signal strength is passing to the monitor link from the passive tap module – using the 70/30 split ratio module necessary for 8G Fibre Channel transmission – cable distance for the monitor portion of the link is necessarily limited to 5 m.

What are my link design options with the Pretium EDGE® Tap Module?

Consistent with the flexibility that Pretium EDGE Solutions offers, the Pretium EDGE Tap Module offers a variety of design options, based on your network’s unique needs. Below are a few possibilities:

Monitor Electronics and Transceiver Collocate

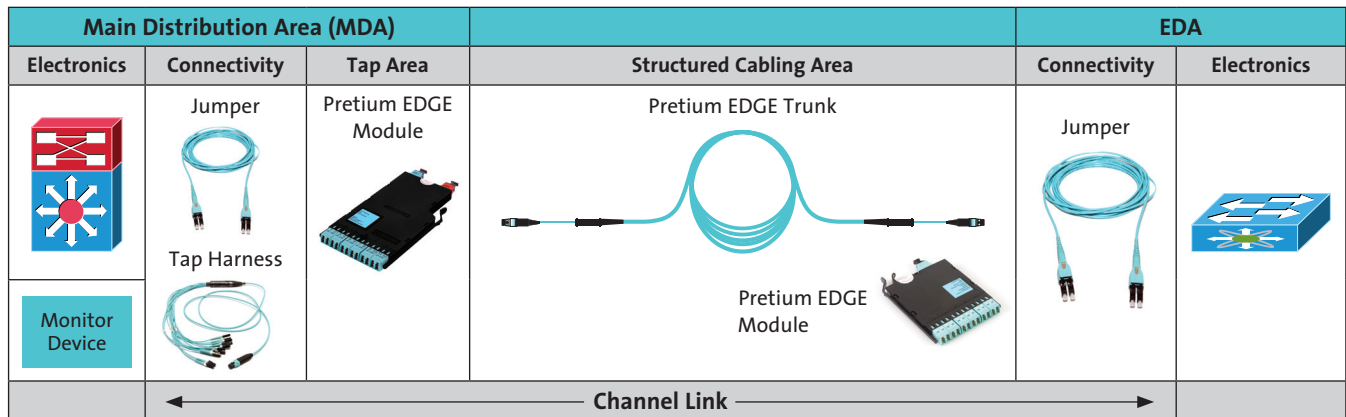

The advantage of this design is that you could add it into your current Pretium EDGE Solutions cabling infrastructure today (assuming the total channel link length is capable), swapping out your standard Pretium EDGE Module with a Pretium EDGE Tap Module – either to begin passive tapping or to replace your current passive tap device with a higher-density, integrated module. However, this design does force jumper connectivity to the transceivers, which can create congestion or less-than-ideal jumper management at the electronics.

Just the Technical Facts

Pretium EDGE® Tap Module as Cross-Connect

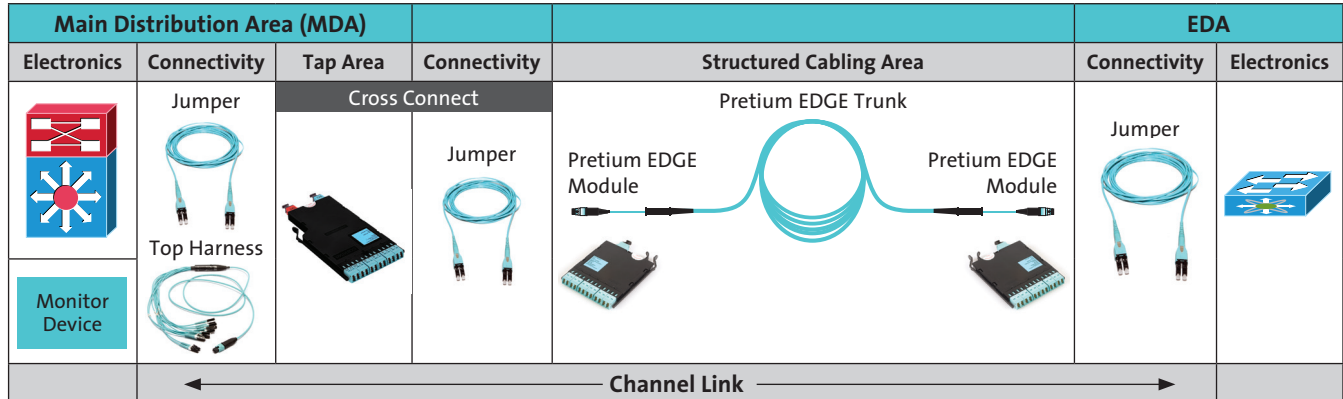

The advantage of this design is that it replicates the ports in your structured cabling area to create a cross-connect area. This provides the advantage of additional design and network management flexibility. In addition, the use of harnesses from the tap module to the electronics enables them to be located farther away without cable pathway congestion, so that you can easily consolidate all of your monitoring equipment and allow each piece of monitoring equipment to be fully utilized. And now you can fully segregate the monitoring electronics from the transceivers, eliminating the risk of a patching error in the monitoring cabinet creating any downtime of the live network.

Monitoring Electronics Remotely/Separately Located

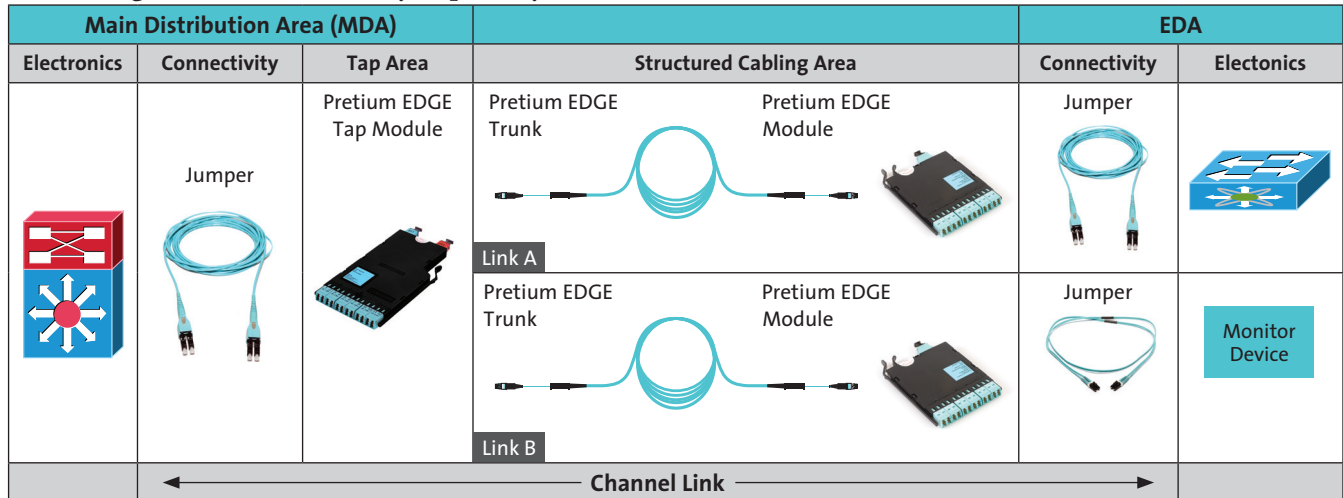

The advantage of this option is that it allows the monitoring electronics to be completely separated from the live network electronics, limiting network access to network administrators and monitoring access to data security/compliance administrators. However, this design is practical only for 10G Ethernet networks, as 8G Fibre Channel is limited to 5 m in the monitor link B.

How do I calculate the total loss of the module for my link budget (spec sheet insertion loss)?

Your module will actually have two possible link loss budgets. It depends on whether data is traveling fully through the module from the Live MTP® connector through to the LC (or from the LC through to the Live and Tap MTP connectors) or passing only from the Live MTP connector to the Tap MTP connector. In both scenarios, you must also add in the attenuation of the coupler inside the module – if you are using the 50/50 power split module, these will always be equal of course, but if you use the 70/30 module, your loss depends on whether the link has live traffic or tap traffic.

Just the Technical Facts

Fiber Type	Split Ratio Live/Tap	Part Number	Module Port Density	Attenuation Live/Tap MM-850 nm SM-1310 nm	MTP Insertion Loss	LC Insertion Loss	Polarity
OM4	50/50	ETM-5B-Q	6	3.8/3.8	.35 dB	.15 dB	Universal
OM4	70/30	ETM-7B-Q	6	1.8/6.6	.35 dB	.15 dB	Universal
OS2	50/50	ETM-5B-G	6	3.6/3.6	.75 dB	.5 dB	Universal
OS2	70/30	ETM-7B-G	6	2.0/6.6	.75 dB	.5 dB	Universal

For the 50/50 OM4 module, this is a fairly straightforward calculation

- LC to MTP® connector (or MTP connector to LC): 4.3 dB (.35 dB for Live MTP connector + .15 dB for LC + 3.8 dB for coupler)
- MTP connector to MTP connector: 4.5 dB (0.35 dB for Live MTP connector + 0.35 dB for Tap MTP connector + 3.8 dB for coupler)

If you'd rather not calculate each individual fiber's loss, you can know that the absolute maximum insertion loss for a 50/50 module is 4.5 dB = the insertion loss of the two MTP connectors plus the coupler technology. Half the fibers in the link will actually have an insertion loss 0.2 dB lower than that.

For the 70/30 OM4 module, where the coupler technology plays a far more limiting role on the monitoring traffic's loss budget, you will likely need to calculate each fiber. But these will always be one of three possibilities:

- Live traffic LC to MTP connector (or vice versa): 2.3 dB (.35 dB for Live MTP connector + .15 dB for LC + 1.8 dB for coupler)
- Monitor traffic LC to MTP connector (or vice versa): 7.1 dB (.35 dB for Live MTP connector + .15 dB for LC + .6 dB for coupler)
- Monitor traffic MTP connector to MTP connector: 7.3 dB (.35 dB for Live MTP connector + .35 dB for Tap MTP connector + 6 dB for coupler)

Again, you can simplify this somewhat by assuming a maximum loss of 2.3 dB for live traffic and 7.3 dB for monitor traffic.

Why do I need to use a Tap Module Harness (previously known as the Plug & Play™ Module Harness) for the tap port of the Pretium EDGE® Tap Module?

Port monitoring electronics use simplex LC connectivity (as all ports are receive ports, versus transmit/receive duplex ports). While Pretium EDGE harnesses and jumpers use our exclusive uniboot duplex LC design that allows polarity management without having to separate the LCs, the Tap Module Harness allows the duplex LCs to be separated for use in the monitoring electronics. You would continue to use a standard Pretium EDGE trunk or harness for the live traffic MTP connector port on the Pretium EDGE Tap Module.

Testing and Troubleshooting

How do I test a Pretium EDGE Tap Module?

Optical splitter devices are often bi-directional (they can manage transmit/receive signals from both directions). But each fiber within the device – whether fused-together cores or reflective devices in/near the core – is optimized to manage this traffic in one direction, typically the transmit direction. Send light down the optimized transmission path and the light splits to the expected paths and with the expected loss results. Send the light upstream against its optimized downstream path and unacceptably high losses result.

You are also sending light to two different types of electronics (transceivers and monitoring devices).

Just the Technical Facts

With this in mind, it is important to remember these key steps as part of your testing:

1. You must test directionally – sending light down the tap module’s even-numbered ports, whose fibers are optimized to carry transmitting traffic, and measuring light from the tap module’s odd-numbered ports, whose fibers are optimized to carry receiving traffic
2. There are three simultaneous aspects of the link to test – the two ends of the live link as well as the monitor link end.
If the tap module is in another location, there will be three discrete locations to test
3. You will need to determine your allowable loss budgets for the total link, which includes
 - The live link
 - The monitoring link from the closest transceiver (tap near)
 - The monitoring link from the farthest transceiver (tap far)

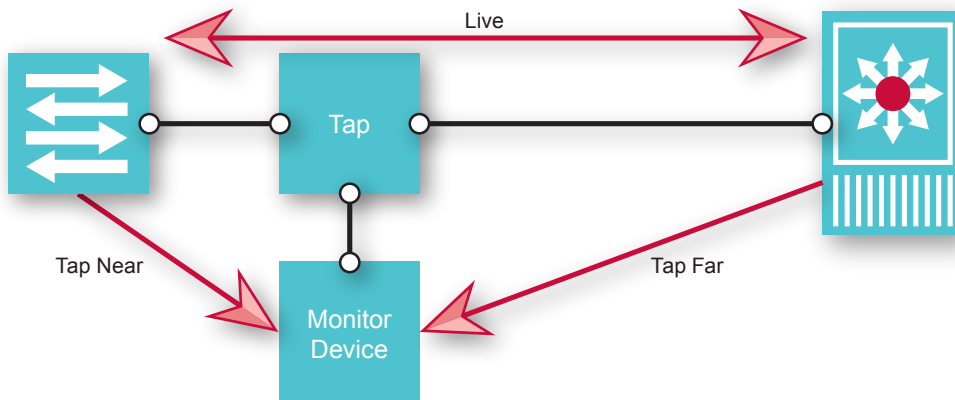

Just the Technical Facts

Just the Technical Facts

Just the Technical Facts