



GSA prices effective March 7, 2022
(based on January 4, 2022, commercial price list)
Published August 2022

Multipurpose Seating

New Aeron® Chairs

General Services Administration Federal Supply Service Authorized Federal Supply Schedule Price List

Online access to contract ordering information, terms and conditions, up-to-date pricing, and the option to create an electronic delivery order is available through GSA Advantage!®, a menu-driven database system.

The Internet address for GSA Advantage! is www.gsaadvantage.gov.

Office Furniture
FSC/PSC 7110/7125
Contract Number: GS-03F-036DA
Contract Period: December 21, 2015—December 20, 2025

MillerKnoll, Inc.
855 East Main Avenue
Zeeland, Michigan 49464
(616) 654 3000 Phone
(616) 654 8278 Fax
www.HermanMiller.com/government

Business Size: Large

Contract Information

1a. Special Item Numbers (SIN)

SIN 33721

Furniture Systems, Computer Furniture, Filing and Storage, Tables and Accessories, Upholstered Seating and Multi-Purpose Seating, Project Management, Reconfiguration and Relocation Services, Design/Layout and Installation Services

SIN 33721P

Packaged Offices

SIN 337127

Modular Laboratory Furniture Systems

SIN NEW

New Product Introductions

SIN OLM

Order-Level Materials (OLMs)

This SIN is only for products and/or services used in direct support of the purchase of new furniture. It requires approval from the ordering Contract Officer. Please contact your local MillerKnoll Inc. representative to discuss the appropriate use of this SIN.

SIN 532289

Leasing

Contact MillerKnoll Inc participating government dealer for current leasing information.

1b. Lowest Priced Model

SIN 33721: G9999.B \$10

1c. Not applicable

2. Maximum Order

SIN 33721, 337127, NEW, OLM

\$250,000 net product value

SIN 33721P

\$5,000,000 net value

3. Minimum Order

\$100 net

4. Geographic Coverage

Continental U.S.

Orders for Alaska, Hawaii, and Puerto Rico will be shipped F.O.B. inland carrier point of exportation.

5. Point of Production

Zeeland, Ottawa County, Michigan

Spring Lake, Ottawa County, Michigan

6. Pricing

Prices shown are list. Discounts include Industrial Funding Fee.

SIN 33721

Standard Lead Time, Single Order Net Purchase \$100 - 250,000, includes approved Herman Miller Options Products.

Product Line	Discount From List
Action Office 1	73.8%
Action Office 2	73.8%
Aeron	64.5%
Aside	64.2%
C-Style Overhead Storage	73.8%
Canvas Office Landscape Channel	74.8%
Canvas Office Landscape Dock	74.8%
Canvas Office Landscape Group	74.8%
Canvas Metal Desk	74.8%
Canvas Office Landscape Metal Storage	74.8%
Canvas Office Landscape Private Office	74.8%
Canvas Office Landscape Wood Storage	74.8%
Canvas Office Landscape Vista	74.8%
Canvas Office Landscape Wall	74.8%
Caper	61.5%
Cosm	61.7%
Eames® Conference & Dining Tables	73.6%
Embody	59.7%
Embody Gaming	37.5%
Ethospace System	73.8%
Everywhere™ Tables	73.8%
Headway™ Tables	73.8%
Keyn	57.7%
Layout Studio®	60.7%
Lino	63.7%
Meridian Laterals	67.3%
Meridian Pedestals	64.2%
Meridian Towers	62.7%
Meridian Storage	62.7%
Mirra 2	61.7%
Motia Tables	73.8%
Nevi™ Tables	73.8%
Nevi Link	73.8%
OE1 Boundary	72.8%
OE1 Micro Packs	73.8%
OE1 Storage	72.8%
OE1 Tables and Benching	73.8%
Overlay™	62.7%
Plex® Lounge Furniture	59.5%
Renew™ Tables	73.8%
Renew Link	73.8%
Sayl	62.2%
Setu	59.7%
Swoop Lounge Furniture	60.7%
Thrive Portfolio	62.0%
Tu Lateral Files	74.3%
Tu Pedestals	73.8%
Tu Storage	74.3%
Tu Towers	74.3%
Tu Wood Cases	74.3%
Tu Wood Cubbies	74.3%
Tu Wood Credenzas	74.3%
Tu Wood Pedestals	74.3%
Tu Wood Towers	74.3%
Valor™ Family	54.91%
Verus	63.7%
Whisk	54.91%

Contract Information

continued

Services

Please refer to section 19 for Terms and Conditions of Installation/ Reconfiguration and Relocation Services.

Project Management

Services under this SIN may be used only in conjunction with the purchase of new furniture. Please contact your local MillerKnoll Inc. representative to discuss the available labor categories (listed below). The hourly rates listed are "Not To Exceed" or "NTE" values.

Furniture Project Manager: \$64.75 per hour
Furniture Project Coordinator: \$49.00 per hour
Build-Out Project Manager: \$80.00 per hour

Reconfiguration and Relocation Services

Reconfiguration and Relocation Services will be provided by MillerKnoll Inc. or its participating dealer based on a fee not to exceed \$55 per hour.

See * Additional Notes for Installation & Reconfiguration and Relocation Services.

Design/Layout

Design service will be provided by MillerKnoll Inc. or its participating dealer based on a fee not to exceed \$65 per hour.

Installation Services

Installation Services will be provided by MillerKnoll Inc. or its participating dealer based on a fee not to exceed \$55 per hour (\$82.50 per hour for after-hours Installation).

See * Additional Notes for Installation & Reconfiguration and Relocation Services.

SIN 337127

Standard Lead Time, Single Order Net Purchase \$100 - 250,000, includes approved Herman Miller Options Products.

Product Line	Discount From List
Action Lab	58.5%
Compass System	58.5%
Co/Struc System	58.5%
Mora System	58.5%
Bedside Cabinets	58.5%

SIN NEW

Standard Lead Time, Single Order Net Purchase \$100 - 250,000, includes approved Herman Miller Options Products.

Product Line	Discount From List
Commend™ Nurses Station	73.3%
Exclave	61.7%
Intent Solution	58.7%
Public Office Landscape	61.7%

SIN 33721P

Packaged Office Furniture - Maximum Order \$5,000,000 (net).

Includes packaged furniture solutions for customers needing to furnish an office.

7. Quantity Discounts

Reference item #6.

8. Payment Terms

Net 30 days

9. Government Commercial Credit Card

- Government commercial credit cards are accepted below the micropurchase threshold.
- Government commercial credit cards are accepted above the micropurchase threshold.

10. Foreign Items

None

11. Time of Delivery

- 90 day ARO
- Expedited delivery: Items listed in the 10-Day section of the catalogs are available for expedited delivery.
- Overnight/2-day delivery: Select items may be available for overnight or 2-day delivery. Contact MillerKnoll Inc. or a participating dealer for availability and rates.
- Urgent requirements: Agencies may contact contractor or participating dealer to request faster delivery.

12. F.O.B.

F.O.B. destination except Alaska, Hawaii, and Puerto Rico, which will be shipped F.O.B. inland carrier point of exportation.

13. Ordering Address

- MillerKnoll Inc.
Government Customer Care 0161
855 East Main Avenue
Zeeland MI 49464.
- For supplies and services, the ordering procedures information on Blanket Purchase Agreements (BPA's) are found in Federal Acquisition Regulation (FAR) 8.405-3.

14. Payment Address.

MillerKnoll Inc.
22764 Network Place
Chicago, IL 60673-1227

15. Warranty

MillerKnoll Inc. commercial warranty applies.

Contract Information

continued

16. Export Packing Charge

Prices supplied on request.

17. Terms and Conditions of Government Purchase Card Acceptance

Accepted above and below the micropurchase level.

18. Rental Maintenance and Repair Terms

Not applicable

19. Terms and Conditions of Installation/Reconfiguration and Relocation Services

* Additional Notes for Installation & Reconfiguration and Relocation Services:

FOB Destination (Drop Ship): Price includes product delivery to the site, brought to the tailgate of the truck. The purchaser is responsible for unloading.

Prices effective up to the maximum order by SIN only. Above the MO, pricing shall be negotiated on a case-by-case basis between the client and local dealer.

Standard Services are Subject to the Following Conditions:

Installation will be performed during normal weekday working hours.

Adequate facilities for delivery, unloading, moving and staging/storing the product during the installation process shall be provided.

Service work will not be hindered by other trades.

Electric, heat, and adequate elevator service will be furnished without charge.

The immediate installation area shall be complete and free of debris including the carpet/flooring before installation commences.

Any work requiring a licensed electrician is the responsibility of the buyer.

Additional Charges May Apply For:

Major Metro Markets and any non-ground floor installation.

Major Metro Markets include large population centers and urban environments.

Installation in a clinical/medical environment.

Special restrictions or limits established by local laws, ordinances or the directions of the buyer, including but not limited to restrictions on transportations of materials, street access to the job site and/or dock facilities.

Installations outside of a 50 mile radius of the servicing dealer.

Local Prevailing Wage and/or Union Labor Rates.

Any additional charges shall be quoted by the dealer and approved by the buyer prior to performance of the work.

20. Terms and Conditions of Repair Parts

Not applicable

21. Service and Distribution Points

For service and distribution points nearest you, call (800) 851 1196.

22. Participating Dealers

Access Herman Miller web site for current list of participating dealers: www.HermanMiller.com/where-to-buy/contact-a-dealer/. Select your market by using the filter.

23. Preventive Maintenance

Not applicable

24a. Special Attributes.

2019

TIME Magazine names Cosm to its list of the 100 Best Inventions of 2019.

Working Mother Magazine names Herman Miller one of the 100 Best Companies for Working Mothers in 2019.

Herman Miller named #12 Overall and #2 in Manufacturing on Investor's Business Daily Best ESG (Environmental, Social, Governance) Companies.

Herman Miller named Silver Level Employer in the Michigan Veterans Affairs Agency Veteran-Friendly Employer Program.

Herman Miller named "Frontrunner" in Chemical Footprint Project by Clean Production Action for our chemical management policies and practices.

Herman Miller receives International Interior Design Association and Contract's best showroom design award in the "Large Showroom" category at NeoCon.

Herman Miller earns its 12th consecutive perfect score in Human Rights Campaign (HRC) Foundation's 2019 Corporate Equality Index.

Geiger One Casegoods receives a Best of NeoCon Silver in the "Case Goods" category.

Cosm receives a Red Dot Best of the Best Product Design Award in the "Office Chairs" category.

Cosm receives Gold at the New York DRIVENxDESIGN Award in the Product Design—Office category.

Lino receives an iF Design Award in the Product Design category.

2018

Herman Miller receives the Corporation of the Year—Consumer Products award from the Michigan Minority Supplier Development Council.

Herman Miller achieves the Advanced Excellence in Supplier Diversity Award from the Great Lakes Women's Business Council for doing business with women-owned suppliers.

Contract Information

continued

As one of the top-scoring companies in the industry for the fourteenth consecutive year, Herman Miller has qualified for inclusion in RobecoSAM's 2018 Sustainability Yearbook and received the Silver Class distinction for excellent sustainability performance—economic, environmental, and social.

Aeron receives Good Design Award from The Chicago Athenaeum Museum of Architecture and Design.

The Cosm Chair won the 2018 Best of NeoCon Gold Award in the Ergonomic Seating Category, the Interior Design HiP Award in the Ergonomic Seating Category, and a #MetropolisLikes Award. Cosm also won Mix Interiors "Product of the Year—Task" award.

For the 11th consecutive year, Herman Miller received a perfect score on the Corporate Equality Index and we were designated as Best Place to Work for LGBT equality. This report evaluates U.S. companies in terms of diversity, particularly their LGBT-related policies and practices.

2017

Herman Miller was named the 2017 "Corporation of the Year" in the consumer products sector by the Michigan Minority Supplier Development Council (MMSDC).

Herman Miller has received a 2017 SEAL (Sustainability, Environmental Achievement and Leadership) Business Sustainability Award.

Herman Miller has earned the 4 Star Diversity Visionary Award. This award celebrates the diversity, equality, and inclusion work of Herman Miller. The award is presented at the annual Diversity Equity Inclusion Summit, held by the Grand Rapids Area Chamber of Commerce.

Herman Miller named one of the Best and Brightest in Wellness for the fifth year in a row.

Working Mother magazine has recognized Herman Miller as one of the 2017 Working Mother 100 Best Companies.

Herman Miller earned our tenth consecutive perfect score in Human Rights Campaign (HRC) Foundation's 2017 Corporate Equality Index.

As one of the top-scoring companies in our industry for the thirteenth consecutive year, Herman Miller has qualified for inclusion in RobecoSAM's 2017 Sustainability Yearbook and received the Bronze Class distinction for our excellent economic, environmental, and social sustainability performance.

Herman Miller has once again earned the WorldatWork Seal of Distinction, a unique standard of excellence in work-life effectiveness that shows we provide a distinct, mutually beneficial workplace experience.

2016

Herman Miller was recognized as the Business of the Year at the Annual Meeting of the West Michigan Environmental Action Council (WMEAC). This award goes to the business with the greatest depth and breadth of support, unwavering dedication to environmental action in West Michigan, and a strong corporate commitment to environmental advocacy.

The 101 Best and Brightest Sustainable Companies once again (fifth consecutive year) recognized Herman Miller as an organization in Michigan (and for the first time, in the nation) that exhibits leadership and innovation in its approach to sustainability.

Herman Miller has been recognized by the Michigan Minority Supplier Development Council (MMSDC), as a "Corporation of the Year", and we also received a "2016 Excellence in Supplier Diversity Award" from the Great Lakes Women's Business Council. Additionally, we are the only West Michigan company this year to receive an "Ambassadors Championing Excellence" Award from the MMSDC.

Plex Lounge Furniture from Herman Miller receives #MetropolisLikes award at NeoCon 2016.

Plex Lounge Furniture from Herman Miller receives Interior Design HiP Award for Workplace Seating/Lounge at NeoCon 2016.

Spot Stools from Herman Miller Collection receive Interior Design HiP Award for Hospitality Seating at NeoCon 2016.

Herman Miller has been named a 2020 Women on Boards Winning Company. Companies selected for this recognition are considered champions of board diversity as 20 percent or more of their board seats are occupied by women.

Herman Miller selected for inclusion in the 2016 RobecoSAM Sustainability Yearbook for twelfth consecutive year.

Herman Miller again earns the WorldatWork Work-Life 2016 Seal of Distinction. This award identifies organizations that focus on programs that promote work-life balance and overall well-being.

2015

Herman Miller earns ninth consecutive perfect score in Human Rights Campaign (HRC) Foundation's 2016 Corporate Equality Index and we were designated as Best Place to Work for LGBT equality.

This is the fourth consecutive year that Herman Miller was named one of Michigan's Best and Brightest Sustainable Companies.

Contract Information

continued

Herman Miller has received the Best and Brightest in Wellness Award for the third year in a row. This program is an innovative initiative that recognizes and celebrates quality and excellence in health awareness.

Herman Miller received the Forest Stewardship Council® (FSC®) Leadership Award for longstanding commitment to manufacturing with wood sourced from responsibly managed forests, which reduces environmental impacts by protecting against deforestation and forest degradation.

Herman Miller accepted its second Excellence in Reusable Packaging Award from the Reusable Packaging Association.

Herman Miller has once again been recognized for its commitment to best-in-class economic, environmental, and societal sustainability, earning a spot on the prestigious Dow Jones Sustainability Index (DJSI) for the twelfth consecutive year. We are the only contract furniture company recognized globally for its corporate sustainability leadership.

Herman Miller selected for inclusion in the 2015 RobecoSAM Sustainability Yearbook; awarded Bronze Class distinction for excellent sustainability performance for the second consecutive year.

Herman Miller received a Michigan Business Pollution Prevention (MBP3) Certificate – a recognition given by the Michigan Department of Environmental Quality (MDEQ) to organizations committed to environmental stewardship, conservation, and sustainable operations. This basic partnership with the MDEQ, which we've maintained since 1998, makes us eligible for our Clean Corporate Citizen (CCC) status that began in 2004 and our Environmental Leader status, which we received for the first time this past year.

MedAssets named Herman Miller Healthcare as Platinum Suppliers. MedAssets, a large group purchasing organization, helps providers enhance operational and financial performance so they can sustainably serve the needs of their community.

Herman Miller honored with five of 20 spots for the Michigan Environmental Leaders Award by the Michigan Department of Environmental Quality for our outstanding, voluntary environmental stewardship.

Renew Sit-to-Stand tables recognized on Record Products 2014 list by Architectural Record.

Herman Miller was again awarded a perfect score in the 2015 Corporate Equality Index. This is the eighth consecutive year we received a perfect score.

2014

Herman Miller has received the Best and Brightest in Wellness Award for the second year in a row. This program is an innovative initiative that recognizes and celebrates quality and excellence in health awareness.

Herman Miller's Locale wins International Design Excellence Awards (IDEA) Gold in the Office & Productivity category.

Herman Miller achieves eleventh consecutive listing on Dow Jones Sustainability World Index, an international stock portfolio that evaluates the annual performance of the world's largest 2500 companies using economic, environmental, and social criteria, known as the "triple bottom line" of sustainability.

2013

Herman Miller achieves tenth consecutive listing on Dow Jones Sustainability World Index.

Herman Miller has received the Best and Brightest in Wellness Award. This program is an innovative initiative that recognizes and celebrates quality and excellence in health awareness.

Herman Miller Earns Perfect Score on the Corporate Equality Index. We are one of only 303 major U.S. businesses to receive a perfect score in 2013, an achievement we have now obtained seven years in a row.

Herman Miller is listed in Forbes Magazine inaugural "Platinum List" of America's 400 best managed, large companies.

For the second consecutive year, Herman Miller is honored as one of West Michigan's "101 Best and Brightest Sustainable Companies".

2012

Herman Miller accepted its first Excellence in Reusable Packaging Award from the Reusable Packaging Association.

Herman Miller is named "Corporation of the Year" in the commercial products sector by the Michigan Minority Supplier Development Council.

In July 2012 Herman Miller was inducted into the Made in the USA Hall of Fame. Herman Miller is one of only 20 companies across the nation to receive this distinction.

Herman Miller achieves ninth consecutive listing on Dow Jones Sustainability World Index.

Herman Miller is honored as one of West Michigan's 101 Best and Brightest Sustainable Companies.

The Sustainable Asset Management (SAM) group selected Herman Miller for inclusion in "The Sustainability Yearbook 2012" and has awarded Herman Miller both the "SAM Sector Leader" and "SAM Sector Mover" distinctions.

Herman Miller was named one of 16 Section Leaders on Climate Counts 2011-2012 Scorecard Report, making us the industry leader for Home and office Furnishings.

Contract Information

continued

SGS International Certification Services Inc. recognizes Herman Miller's manufacturing sites, Midwest Distribution Center, and Design Yard for initial certification to the OHSAS 18001 standard as well as re-certification to ISO 14001.

24b. Section 508 Compliance

Not applicable

25. Data Universal Numbering System (DUNS): 00-601-2801

26. Registered in System for Award Management (www.SAM.gov) Database

Unique Entity ID: Q2K3MSZ843D8

27. Cancellation

Prior to production, no cancellation charge will apply. After production, only actual cost incurred that the contractor can demonstrate if items are sold after 3 months.

28. Restocking Charges

Agencies must notify the contractor for authorization prior to returning any items. The customer agency will be required to pay all packaging and return freight charges. A restocking fee of 50% for Systems Furniture and 35% for all other product lines will be charged for any returned items.

Returns and restocking policy is not applicable to products under SIN 337127.

MillerKnoll Inc. Miscellaneous Information:

Federal ID Number: 38-0837640

Commercial and Government Entity Code (CAGE): 40636

Data Universal Numbering System (DUNS) 00-601-2801

Commercial Entity Code (CEC): 00702290J

Introduction	page 2
New Aeron® Chairs	3
Work Chair	5
Work Chair, Ready to Assemble	9
Work Stool	13
Accessories	17
Indices	25
By Name	25
By Number	27
Appendices	
20-Day or Less/Assigned Lead-Time Order Information	
Size/Fit Reference	
Casters and Glides	
Fire Retardancy-Seating	
Customer's Own Material/Customer's Own Leather Order Information-Seating	
Proprietary Textiles Application Chart-Seating	
Proprietary Textile Colors-Seating	
For the latest materials information, refer to the Materials pages on HermanMiller.com.	

Introduction

A Note on the Organization of This Book

There are a few signals that will help you understand the organization of this book. Once you know them, you should be able to find your way around easily.

Like a newspaper, this book is formatted with columns of text and illustrations that run vertically.

Information wraps from one column to the next and continues for as many pages as it needs to.

Black bars are clues.

A black bar at the top of a page signals the start of information about a product.

This information is divided into two sections, each signaled by a black bar. Product Information includes a description, additional notes, and dimensional drawings. Specification Information, which always begins at the top of a column, includes a series of steps. Each step represents a decision you need to make in order to complete your product number. Steps must be followed sequentially. The number of pages needed to complete information on a product varies; some will be complete in one page; others may fill three or four pages. Just continue going through the steps until you run into the next product, signaled by the black bar at the top of the page.

Black tabs running along the outside edge of the page help you locate what section you are in or what section you want to go to. You can thumb forwards or backwards to find a section; tabs and text appear on both sides of the page.

The additional pages in the back of the book include the appendices and indices. They are signaled by a long black bar running along the outside edge of the page.

The index is presented two ways.

The first index is in alphabetical order by product name. It can be helpful if you are new to the products and numbering scheme or if you are looking for a type of product, such as work chair or round table.

The second index is by product number. It lists, in alphanumeric order, the base product number, typically a five-digit number.

General Information

This book is effective March 7, 2022, subject to change without notice. Products may be purchased from authorized Herman Miller dealers who will quote prices upon request. For more information about our products and services or to see a list of dealers, visit www.HermanMiller.com.

All prices are list prices. Additional services, such as planning services, design, storage, and installation, are not included and must be added to these prices when the additional services are requested.

Illustrations, specifications, and prices are based on the latest information at the time of publication. The right is reserved to make changes at any time without notice in prices, fabrics, finishes, materials, specifications, and models, and also to discontinue models and finishes.

Dimensions shown in the drawings are engineering drawing dimensions rounded up to the nearest $\frac{1}{8}$ ". Product is shipped set up or knocked down. Products that include "Shipped knocked down" in the description require some assembly. If this statement does not appear in the description, the product is shipped assembled.

Service problems are normally handled by a Herman Miller authorized dealer. Where this cannot be accomplished on a local level, service problems should be referred to the Customer Care Representative for your region, Herman Miller, Inc., Zeeland, Michigan 49464.

20-Day or Less/Assigned Lead-Time Shipments

All products and options in this price book not designated by an Assigned Program icon  will ship in **20 business days or less** after being acknowledged by Herman Miller.

Products and options designated by an  are on the assigned lead-time program and may ship in 20 days, less than 20 days, or more than 20 days from order acknowledgement.

Work Chairs

Stools

Accessories



Work Chair

AER1A
AER1B
AER1C



Product Information

Description

While its iconic form has remained largely unchanged, the Aeron® chair has been remastered from the casters up to meet the needs of today's work and workers. With the help of original co-designer, Don Chadwick, we thoughtfully updated the chair based on the latest research around the science of sitting, and advancements in materials, manufacturing, and technology.

The new Aeron chair comes in 3 sizes and has a new 8Z Pellicle® material that delivers increased comfort and ergonomic support. Across the seat and back, 8 latitudinal zones of varying tension envelope the sitter, tightest at the edges and more forgiving where the body makes contact. The chair has pneumatic height adjustment and a balanced recline that lets the body naturally pivot at the ankles, knees, and hips.

Tilt options include a tilt limiter that allows the user to select the tilt range to limit the amount of recline; a tilt limiter and seat angle that allows the user to select the tilt range and a horizontal or 5° forward seat angle; or a standard tilt.

Back-support options include adjustable PostureFit® SL, an adjustable lumbar support, and PostureFit. The adjustable PostureFit SL support provides a custom fit in sacral and lumbar regions of the spine that helps achieve healthier posture and improved lower back comfort. The user can fine tune the level of support with an adjustable knob on the PostureFit SL.

Arm choices include a fixed, nonadjustable option; a height-adjustable option that moves the arms 4" vertically; a height-adjustable plus pivot option that moves the arms 4" vertically and pivots the armpads 15° outward and 17½° inward; and a fully adjustable option that also allows the armpads to move forward and back.

Aeron is now offered in a range of 3 tightly curated, holistic material expressions: graphite, carbon, and mineral. Graphite refines Aeron's original color scheme for a crisp, sculptural appearance. Carbon blurs light and dark, and warm and cool, to harmonize with a variety of environments. Mineral illuminates Aeron's finer points to offer a lightness that borders on translucence.

The graphite with graphite applique (ZB) frame finish includes appliques that are applied to an Aeron® work chair's seat, back, and arms to minimize the effect of contact between the chair and a wood-edge surface.

Notes

To help determine chair size, see Aeron Chair Size/Fit Reference in Appendices.

For information on casters and glides, see Casters and Glides in Appendices.

Customer's Own Leather (COL) can be applied to armpads; requires 4 square feet. See Order Information in Appendices.

As with any material or textile, dye transfer may occur on seating surfaces, being more noticeable on lighter color expressions (for example: mineral on Aeron, fog on Mirra® 2). If this is a concern, we recommend selecting a darker color expression on which dye transfer will be less noticeable. As a reminder, dye transfer is not covered under the Herman Miller warranty.

MicrobeCare™ is an antimicrobial coating that can be applied to a wide variety of Herman Miller Group surfaces to protect products from mold, mildew, algae, and bacteria that cause deterioration, discoloration, odors, and stains.

MicrobeCare™ is a US Environmental Protection Agency (EPA) registered nonpublic health antimicrobial.

MicrobeCare™ is applied to the major touchpoints, including the seat, backrest, arms, armrests, frame and adjustment controls.

Dimensions

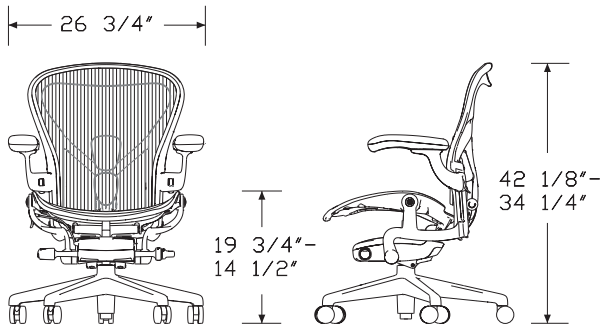

Low Height Range

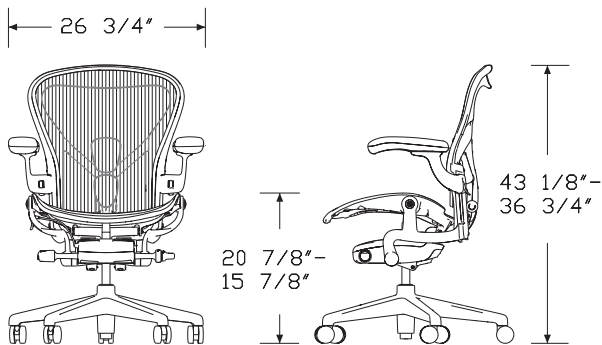

Standard Height Range

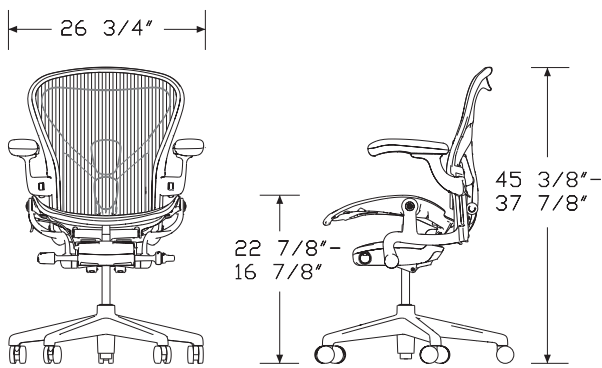

High Height Range

Specification Information

Step 1.

AER1

Step 2. Size

A	a size	+\$1440
B	b size	+\$1440
C	c size	+\$1440

Step 3. Height Adjustment

For a size (A)

1	low-height range	+\$0
----------	------------------	------

For b size (B)

1	low-height range	+\$0
2	standard-height range	+\$0
3	high-height range	+\$0

For c size (C)

2	standard-height range	+\$0
3	high-height range	+\$0

Step 4. Tilt

1	standard tilt	+\$0
2	tilt limiter	+\$81
3	tilt limiter and seat angle	+\$172

Step 5. Arms

N	no arms	+\$0
P	fixed arms	+\$179
H	height-adjustable arms	+\$266
A	height-adjustable plus pivot arms	+\$368
D	fully adjustable arms	+\$393

Step 6. Armpad Upholstery

For no arms (N)

N	no arms	+\$0
----------	---------	------

For fixed arms (P), height-adjustable arms (H), height-adjustable plus pivot arms (A), or fully adjustable arms (D)

W	nonupholstered armpads	+\$0
F	leather armpads	+\$97

Step 7. Fire Retardancy
 For not fire retardant (*), skip this step.

For a size (A) or b size (B), skip this step.
 not fire retardant +\$0

For c size (C)
 not fire retardant +\$0

Step 8. Back Support Option

SZS	basic back support	+\$0
ZSS	PostureFit®	+\$45
AJ	adjustable lumbar support	+\$65
ALP	adjustable posturefit SL	+\$95

Step 9. Frame Finish

For a size (A) or b size (B) with not fire retardant

BK	black	+\$130
MBL	black with MicrobeCare™ A	+\$200
G1	graphite	+\$0
CRB	carbon	+\$85
VPR	mineral	+\$175
ZB	graphite with graphite applique	+\$325
MG1	graphite with MicrobeCare™ A	+\$70
MCR	carbon with MicrobeCare™ A	+\$155
MVR	mineral with MicrobeCare™ A	+\$245
MZB	graphite with graphite applique and MicrobeCare™ A	+\$395

For c size (C) with not fire retardant

BK	black	+\$130
MBL	black with MicrobeCare™ A	+\$200
G1	graphite	+\$0
CRB	carbon	+\$85
VPR	mineral	+\$175
ZB	graphite with graphite applique	+\$325
MG1	graphite with MicrobeCare™ A	+\$70
MCR	carbon with MicrobeCare™ A	+\$155
MVR	mineral with MicrobeCare™ A	+\$245
MZB	graphite with graphite applique and MicrobeCare™ A	+\$395

Step 10. Chassis Finish

For not fire retardant with graphite (G1), or graphite with MicrobeCare™ (MG1)

G1	graphite	+\$0
CD	polished aluminum A	+\$85

For not fire retardant with graphite with graphite applique (ZB), or graphite with graphite applique and MicrobeCare™ (MZB)

G1	graphite	+\$0
-----------	----------	------

For not fire retardant with carbon (CRB), or carbon with MicrobeCare™ (MCR)

SNC	satin carbon	+\$0
CD	polished aluminum A	+\$85

For not fire retardant with mineral (VPR), or mineral with MicrobeCare™ (MVR)

SNA	satin aluminum	+\$0
CD	polished aluminum A	+\$85

For not fire retardant with black (BK), or black with MicrobeCare™ (MBL)

BLX	onyx ultra matte	+\$0
CD	polished aluminum	+\$85

Step 11. Base Finish

For not fire retardant with graphite (G1)

G1	graphite	+\$0
CD	polished aluminum A	+\$250

For not fire retardant with graphite (G1)

G1	graphite	+\$0
CD	polished aluminum	+\$250

For not fire retardant with polished aluminum (CD)

CD	polished aluminum A	+\$250
-----------	----------------------------	--------

For not fire retardant with satin carbon (SNC)

DCR	dark carbon	+\$0
SNC	satin carbon	+\$80
CD	polished aluminum A	+\$250

For not fire retardant with polished aluminum (CD)

CD	polished aluminum A	+\$250
-----------	----------------------------	--------

For not fire retardant with satin aluminum (SNA)

DVP	dark mineral	+\$0
SNA	satin aluminum	+\$150
CD	polished aluminum A	+\$250

For not fire retardant with polished aluminum (CD)

CD	polished aluminum A	+\$250
-----------	----------------------------	--------

<i>For not fire retardant with onyx ultra matte (BLX)</i>		
BK	black	+\$0
BLX	onyx ultra matte	+\$115
CD	polished aluminum	+\$250

<i>For not fire retardant with polished aluminum (CD)</i>		
CD	polished aluminum A	+\$250

Step 12. Casters/Glides		
<i>For black (BK), onyx ultra matte (BLX), polished aluminum (CD), dark carbon (DCR), dark mineral (DVP), graphite (G1), satin aluminum (SNA), or satin carbon (SNC)</i>		
BB	2½" hard caster, black yoke, carpet only	+\$0
GF	2½" glide, hard floors or carpet	+\$25
C7	2½" caster, black yoke, hard floors or carpet	+\$50
DC1	2½" braking caster, black yoke, hard floors or carpet with quiet roll technology	+\$75

Step 13. Armpad Finish		
<i>For nonupholstered armpads (W) with not fire retardant with black (BK), black with MicrobeCare™ (MBL), graphite (G1), or graphite with graphite applique (ZB), or graphite with MicrobeCare™ (MG1), or graphite with graphite applique and MicrobeCare™ (MZB)</i>		
BK	black	+\$0

<i>For nonupholstered armpads (W) with not fire retardant with mineral (VPR), or mineral with MicrobeCare™ (MVR)</i>		
DVP	dark mineral	+\$0

<i>For nonupholstered armpads (W) with not fire retardant with carbon (CRB), or carbon with MicrobeCare™ (MCR)</i>		
DCR	dark carbon	+\$0

Step 14. 8Z Pellicle		
<i>For not fire retardant with graphite (G1), graphite with graphite applique (ZB), or graphite with MicrobeCare™ (MG1), or graphite with graphite applique and MicrobeCare™ (MZB)</i>		
Price Category 1		+\$0

<i>For not fire retardant with mineral (VPR), or mineral with MicrobeCare™ (MVR)</i>		
Price Category 1		+\$0

<i>For not fire retardant with carbon (CRB), or carbon with MicrobeCare™ (MCR)</i>		
Price Category 1		+\$0

<i>For not fire retardant with black (BK), or black with MicrobeCare™ (MBL)</i>		
Price Category 1		+\$0

Step 15. Armpad Leather		
<i>For leather armpads (F)</i>		
Price Category 7		+\$0
Price Category 9		+\$75

Work Chair, Ready to Assemble

AER2A
AER2B
AER2C



Product Information

Description

While its iconic form has remained largely unchanged, the Aeron® chair has been remastered from the casters up to meet the needs of today's work and workers. With the help of original co-designer, Don Chadwick, we thoughtfully updated the chair based on the latest research around the science of sitting, and advancements in materials, manufacturing, and technology.

The new Aeron chair comes in 3 sizes and has a new 8Z Pellicle® material that delivers increased comfort and ergonomic support. Across the seat and back, 8 latitudinal zones of varying tension envelope the sitter, tightest at the edges and more forgiving where the body makes contact. The chair has pneumatic height adjustment and a balanced recline that lets the body naturally pivot at the ankles, knees, and hips. Chair components are packaged and shipped ready to assemble.

Tilt options include a tilt limiter that allows the user to select the tilt range to limit the amount of recline; a tilt limiter and seat angle that allows the user to select the tilt range and a horizontal or 5° forward seat angle; or a standard tilt.

Back-support options include adjustable PostureFit® SL, an adjustable lumbar support, and PostureFit. The adjustable PostureFit SL support provides a custom fit in sacral and lumbar regions of the spine that helps achieve healthier posture and improved lower back comfort. The user can fine tune the level of support with an adjustable knob on the PostureFit SL.

Arm choices include a fixed, nonadjustable option; a height-adjustable option that moves the arms 4" vertically; a height-adjustable plus pivot option that moves the arms 4" vertically and pivots the armpads 15° outward and 17½° inward; and a fully adjustable option that also allows the armpads to move forward and back.

Aeron is now offered in a range of 3 tightly curated, holistic material expressions: graphite, carbon, and mineral. Graphite refines Aeron's original color scheme for a crisp, sculptural appearance. Carbon blurs light and dark, and warm and cool, to harmonize with a variety of environments. Mineral illuminates Aeron's finer points to offer a lightness that borders on translucence.

The graphite with graphite applique (ZB) frame finish includes appliques that are applied to an Aeron® work chair's seat, back, and arms to minimize the effect of contact between the chair and a wood-edge surface.

Notes

To help determine chair size, see Aeron Chair Size/Fit Reference in Appendices.

For information on casters and glides, see Casters and Glides in Appendices.

Customer's Own Leather (COL) can be applied to armpads; requires 4 square feet. See Order Information in Appendices.

Note: As with any material or textile, dye transfer may occur on seating surfaces, being more noticeable on lighter color expressions (for example: mineral on Aeron, fog on Mirra® 2). If this is a concern, we recommend selecting a darker color expression on which dye transfer will be less noticeable. As a reminder, dye transfer is not covered under the Herman Miller warranty.

MicrobeCare™ is an antimicrobial coating that can be applied to a wide variety of Herman Miller Group surfaces to protect products from mold, mildew, algae, and bacteria that cause deterioration, discoloration, odors, and stains.

MicrobeCare™ is a US Environmental Protection Agency (EPA) registered nonpublic health antimicrobial.

MicrobeCare™ is applied to the major touchpoints, including the seat, backrest, arms, armrests, frame and adjustment controls.

Work Chair, Ready to Assemble

continued

New Aeron® Work Chairs

Dimensions

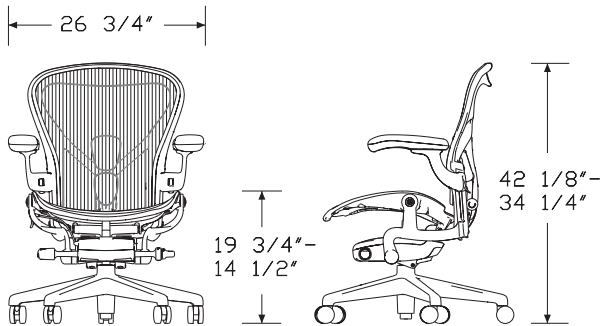

Low Height Range

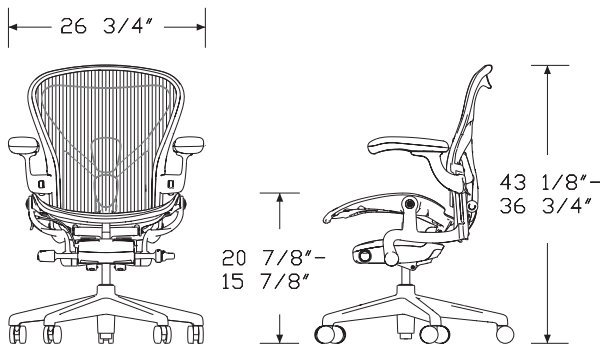

Standard Height Range

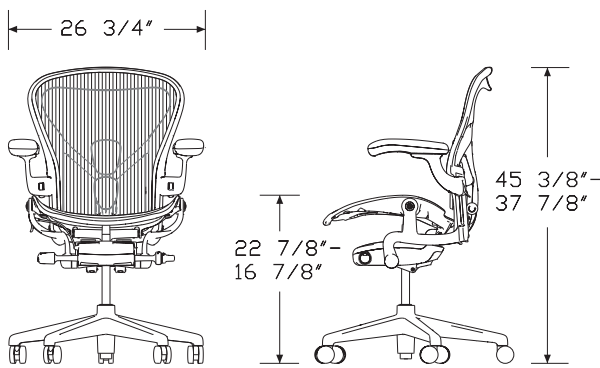

High Height Range

Specification Information

Step 1.

AER2

Step 2. Size

A	a size	+\$1440
B	b size	+\$1440
C	c size	+\$1440

Step 3. Height Adjustment

For a size (A)

1	low-height range	+\$0
----------	------------------	------

For b size (B)

1	low-height range	+\$0
2	standard-height range	+\$0
3	high-height range	+\$0

For c size (C)

2	standard-height range	+\$0
3	high-height range	+\$0

Step 4. Tilt

1	standard tilt	+\$0
2	tilt limiter	+\$81
3	tilt limiter and seat angle	+\$172

Step 5. Arms

N	no arms	+\$0
P	fixed arms	+\$179
H	height-adjustable arms	+\$266
A	height-adjustable plus pivot arms	+\$368
D	fully adjustable arms	+\$393

Step 6. Armpad Upholstery

For no arms (N)

N	no arms	+\$0
----------	---------	------

For fixed arms (P), height-adjustable arms (H), height-adjustable plus pivot arms (A), or fully adjustable arms (D)

W	nonupholstered armpads	+\$0
F	leather armpads	+\$97

Work Chair, Ready to Assemble

continued

Step 7. Fire Retardancy	
<i>For not fire retardant (*), skip this step.</i>	
not fire retardant	+\$0

Step 8. Back Support Option	
SZS basic back support	+\$0
ZSS PostureFit®	+\$45
AJ adjustable lumbar support	+\$65
ALP adjustable posturefit SL	+\$95

Step 9. Frame Finish	
BK black	+\$130
G1 graphite	+\$0
CRB carbon	+\$85
VPR mineral	+\$175
ZB graphite with graphite applique	+\$325

Step 10. Chassis Finish

<i>For not fire retardant with graphite (G1)</i>	
G1 graphite	+\$0
CD polished aluminum A	+\$85

<i>For not fire retardant with graphite with graphite applique (ZB)</i>	
G1 graphite	+\$0

<i>For not fire retardant with carbon (CRB)</i>	
SNC satin carbon	+\$0
CD polished aluminum A	+\$85

<i>For not fire retardant with mineral (VPR)</i>	
SNA satin aluminum	+\$0
CD polished aluminum A	+\$85

<i>For not fire retardant with black (BK)</i>	
BLX onyx ultra matte	+\$0
CD polished aluminum	+\$85

Step 11. Base Finish

<i>For not fire retardant with graphite (G1)</i>	
G1 graphite	+\$0
CD polished aluminum A	+\$250

<i>For not fire retardant with graphite (G1)</i>	
G1 graphite	+\$0
CD polished aluminum	+\$250

<i>For not fire retardant with polished aluminum (CD)</i>	
CD polished aluminum A	+\$250

<i>For not fire retardant with satin carbon (SNC)</i>	
DCR dark carbon	+\$0
SNC satin carbon	+\$80
CD polished aluminum A	+\$250

<i>For not fire retardant with polished aluminum (CD)</i>	
CD polished aluminum A	+\$250

<i>For not fire retardant with satin aluminum (SNA)</i>	
DVP dark mineral	+\$0
SNA satin aluminum	+\$150
CD polished aluminum A	+\$250

<i>For not fire retardant with polished aluminum (CD)</i>	
CD polished aluminum A	+\$250

<i>For not fire retardant with onyx ultra matte (BLX)</i>	
BK black	+\$0
BLX onyx ultra matte	+\$115
CD polished aluminum	+\$250

<i>For polished aluminum (CD)</i>	
CD polished aluminum A	+\$250

Step 12. Casters/Glides

For black (BK), onyx ultra matte (BLX), polished aluminum (CD), dark carbon (DCR), dark mineral (DVP), graphite (G1), satin aluminum (SNA), or satin carbon (SNC)

BB 2 1/2" hard caster, black yoke, carpet only	+\$0
GF 2 1/2" glide, hard floors or carpet	+\$25
C7 2 1/2" caster, black yoke, hard floors or carpet	+\$50
DC1 2 1/2" braking caster, black yoke, hard floors or carpet with quiet roll technology	+\$75

Step 13. Armpad Finish

<i>For nonupholstered arm pads (W) with not fire retardant with black (BK), or graphite (G1), or graphite with graphite applique (ZB)</i>	
BK black	+\$0

<i>For nonupholstered arm pads (W) with not fire retardant with mineral (VPR)</i>	
DVP dark mineral	+\$0

Work Chair, Ready to Assemble

continued

New Aeron® Work Chairs

<i>For nonupholstered armpads (W) with not fire retardant with carbon (CRB)</i>		
DCR	dark carbon	+\$0

Step 14. 8Z Pellicle

<i>For not fire retardant with graphite (G1), or graphite with graphite applique (ZB)</i>		
Price Category 1		+\$0

<i>For not fire retardant with mineral (VPR)</i>		
Price Category 1		+\$0

<i>For not fire retardant with carbon (CRB)</i>		
Price Category 1		+\$0

<i>For not fire retardant with black (BK)</i>		
Price Category 1		+\$0

Step 15. Armpad Leather		
<i>For leather armpads (F)</i>		
Price Category 7		+\$0
Price Category 9		+\$75

Work Stool

AER71
AER72

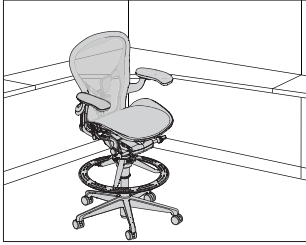

Product Information

Description

While its iconic form has remained largely unchanged, the Aeron® chair and work stool has been remastered from the casters up to meet the needs of today's work and workers. With the help of original co-designer, Don Chadwick, we thoughtfully updated the chair and work stool based on the latest research around the science of sitting, and advancements in materials, manufacturing, and technology.

The new Aeron stool has a new 8Z Pellicle® material that delivers increased comfort and ergonomic support. Across the seat and back, 8 latitudinal zones of varying tension envelope the sitter, tightest at the edges and more forgiving where the body makes contact. The work stool has a 2½"-wide footrest platform that provides three times more surface area than a typical footrest to reduce pressure and increase comfort. Non-slip treads offer added stability. When adjusting stool height, the footrest moves with the seat.

The stool has a 5-star base, pneumatic seat-height adjustment, and 2 height options to allow stool use with counter or bar height surfaces. The low stool has a seat-height range of 24¾" to 29¼" with a footrest that adjusts 2½" (from 15" to 17½" below the seat) and is optimal for work surfaces between 34" and 38" high. The high stool has a seat-height range of 28" to 34¼" with a footrest that adjusts 5¾" (from 15" to 20¾" below the seat) and is optimal for work surfaces between 37" and 43" high. Stool is available in size B.

Tilt options include a tilt limiter that allows the user to select the tilt range to limit the amount of recline; a tilt limiter and seat angle that allows the user to select the tilt range and a horizontal or 5° forward seat angle; or a standard tilt.

Back-support options include adjustable PostureFit® SL, an adjustable lumbar support, and PostureFit. The adjustable PostureFit SL support provides a custom fit in sacral and lumbar regions of the spine that helps achieve healthier posture and improved lower back comfort. The user can fine tune the level of support with an adjustable knob on the PostureFit SL.

Arm choices include a fixed, nonadjustable option; a height-adjustable option that moves the arms 4" vertically; a height-adjustable plus pivot option that moves the arms 4" vertically and pivots the armrests 15° outward and 17½° inward; and a fully adjustable option that also allows the armrests to move forward and back.

Aeron is now offered in a range of 3 tightly curated, holistic material expressions: graphite, carbon, and mineral. Graphite refines Aeron's original color scheme for a crisp, sculptural appearance. Carbon blurs light and dark, and warm and cool, to harmonize with a variety of environments. Mineral illuminates Aeron's finer points to offer a lightness that borders on translucence.

The graphite with graphite applique (ZB) frame finish includes appliques that are applied to an Aeron® work stool's seat, back, and arms to minimize the effect of contact between the stool and a wood-edge surface.

Notes

For information on casters and glides, see Casters and Glides in Appendices.

Customer's Own Leather (COL) can be applied to armrests; requires 4 square feet. See Order Information in Appendices.

As with any material or textile, dye transfer may occur on seating surfaces, being more noticeable on lighter color expressions (for example: mineral on Aeron, fog on Mirra® 2). If this is a concern, we recommend selecting a darker color expression on which dye transfer will be less noticeable. As a reminder, dye transfer is not covered under the Herman Miller warranty.

MicrobeCare™ is an antimicrobial coating that can be applied to a wide variety of Herman Miller Group surfaces to protect products from mold, mildew, algae, and bacteria that cause deterioration, discoloration, odors, and stains.

MicrobeCare™ is a US Environmental Protection Agency (EPA) registered nonpublic health antimicrobial.

MicrobeCare™ is applied to the major touchpoints, including the seat, backrest, arms, armrests, frame and adjustment controls.

Dimensions

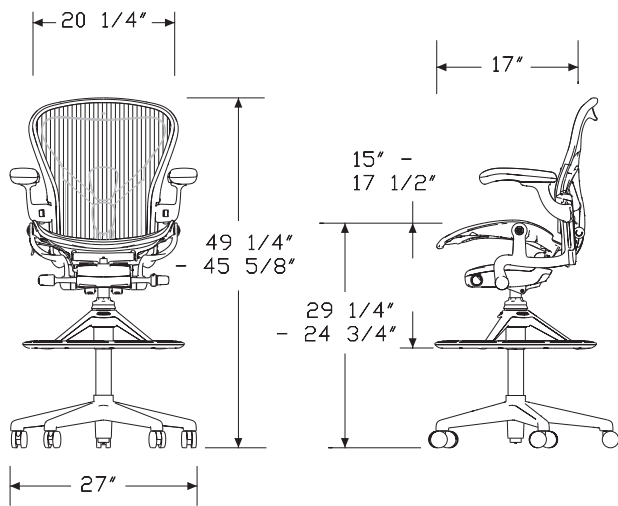

Low Stool

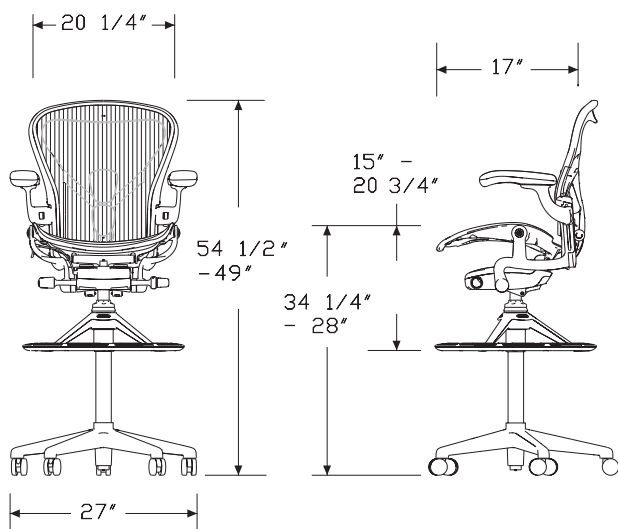

High Stool

Specification Information

Step 1.

AER7

Step 2. Height

1	low	+\$1846
2	high	+\$1846

Step 3. Tilt

1	standard tilt	+\$0
2	tilt limiter	+\$81
3	tilt limiter and seat angle	+\$172

Step 4. Arms

N	no arms	+\$0
P	fixed arms	+\$179
H	height-adjustable arms	+\$266
A	height-adjustable plus pivot arms	+\$368
D	fully adjustable arms	+\$393

Step 5. Armpad Upholstery

For no arms (N)

N	no arms	+\$0
----------	---------	------

For fixed arms (P), height-adjustable arms (H), height-adjustable plus pivot arms (A), or fully adjustable arms (D)

W	nonupholstered armpads	+\$0
F	leather armpads	+\$97

Step 6. Fire Retardancy

For not fire retardant (), skip this step.*

not fire retardant	+\$0
--------------------	------

Step 7. Back Support Option

SZS	basic back support	+\$0
ZSS	PostureFit®	+\$45
AJ	adjustable lumbar support	+\$65
ALP	adjustable posturefit SL	+\$95

Step 8. Frame/Foot Ring Tread

BK	black	+\$130
MBL	black with MicrobeCare™	+\$200
G1	graphite	+\$0
CRB	carbon	+\$85
VPR	mineral	+\$175
ZB	graphite with graphite applique	+\$325
MG1	graphite with MicrobeCare™ A	+\$70
MCR	carbon with MicrobeCare™ A	+\$155
MVR	mineral with MicrobeCare™ A	+\$245
MZB	graphite with graphite applique and MicrobeCare™ A	+\$395

Step 9. Chassis & Foot Ring

For not fire retardant with graphite (G1), or graphite with MicrobeCare™ (MG1)

G1	graphite	+\$0
CD	polished aluminum	+\$85

For not fire retardant with graphite with graphite applique (ZB), or graphite with graphite applique and MicrobeCare™ (MZB)

G1	graphite	+\$0
-----------	----------	------

For not fire retardant with carbon (CRB), or carbon with MicrobeCare™ (MCR)

SNC	satin carbon	+\$0
CD	polished aluminum	+\$85

For not fire retardant with mineral (VPR), or mineral with MicrobeCare™ (MVR)

SNA	satin aluminum	+\$0
CD	polished aluminum	+\$85

For not fire retardant with black (BK), or black with MicrobeCare™ (MBL)

BLX	onyx ultra matte	+\$0
CD	polished aluminum	+\$85

Step 10. Base Finish

For graphite (G1)

G1	graphite	+\$0
CD	polished aluminum	+\$250

For polished aluminum (CD)

CD	polished aluminum A	+\$250
-----------	---	--------

For satin carbon (SNC)

DCR	dark carbon	+\$0
SNC	satin carbon	+\$80
CD	polished aluminum	+\$250

For satin aluminum (SNA)

DVP	dark mineral	+\$0
SNA	satin aluminum	+\$150
CD	polished aluminum	+\$250

For onyx ultra matte (BLX)

BK	black	+\$0
BLX	onyx ultra matte	+\$115
CD	polished aluminum	+\$250

For polished aluminum (CD)

CD	polished aluminum A	+\$250
-----------	---	--------

Step 11. Casters/Glides

For black (BK), onyx ultra matte (BLX), polished aluminum (CD), dark carbon (DCR), dark mineral (DVP), graphite (G1), satin aluminum (SNA), or satin carbon (SNC)

BB	2 1/2" hard caster, black yoke, carpet only	+\$0
GF	2 1/2" glide, hard floors or carpet	+\$25
C7	2 1/2" caster, black yoke, hard floors or carpet	+\$50
DC1	2 1/2" braking caster, black yoke, hard floors or carpet with quiet roll technology	+\$75

Step 12. Armpad Finish

For nonupholstered armpads (W) with not fire retardant with black (BK), black with MicrobeCare™ (MBL), graphite (G1), or graphite with graphite applique (ZB), or graphite with MicrobeCare™ (MG1), or graphite with graphite applique and MicrobeCare™ (MZB)

BK	black	+\$0
-----------	-------	------

For nonupholstered armpads (W) with not fire retardant with mineral (VPR), or mineral with MicrobeCare™ (MVR)

DVP	dark mineral	+\$0
------------	--------------	------

For nonupholstered armpads (W) with not fire retardant with carbon (CRB), or carbon with MicrobeCare™ (MCR)

DCR	dark carbon	+\$0
------------	-------------	------

Step 13. 8Z Pellicle

For not fire retardant with graphite (G1), graphite with graphite applique (ZB), or graphite with MicrobeCare™ (MG1), or graphite with graphite applique and MicrobeCare™ (MZB)

Price Category 1 +\$0

For not fire retardant with mineral (VPR), or mineral with MicrobeCare™ (MVR)

Price Category 1 +\$0

For not fire retardant with carbon (CRB), or carbon with MicrobeCare™ (MCR)

Price Category 1 +\$0

For not fire retardant with black (BK), or black with MicrobeCare™ (MBL)

Price Category 1 +\$0

Step 14. Armpad Leather

For fixed arms (P), height-adjustable arms (H), height-adjustable plus pivot arms (A), or fully adjustable arms (D) with leather armpads (F)

Price Category 7 +\$0

Price Category 9 +\$75

Arm Kit

AER900

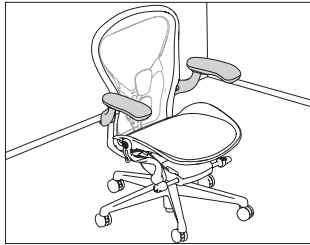

Product Information

Description

These arms can be retrofitted to a new Aeron® work chair. Arm choices include a height adjustable option that moves the arms 4" vertically, a height adjustable plus pivot option that moves the arms 4" vertically and pivots the arm pads 16° outward and 16° inward, and a fully adjustable option that moves the arm pads forward and back 2½".

Arm components are preassembled.

Graphite (G1) finish is recommended for use with the following frame finishes:

- Graphite (G1)
- Graphite with graphite applique (ZB)

Carbon (CRB) finish is recommended for use with carbon (CRB) frame finish.

Mineral (VPR) finish is recommended for use with mineral (VPR) frame finish.

Dimensions

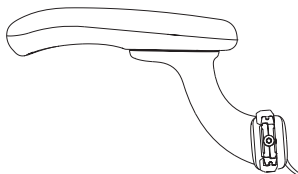

Height adjustable and fully adjustable arms

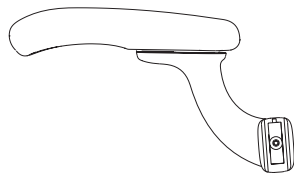

Fixed arms

Specification Information

Step 1.

AER900 A

Step 2. Arms

P	fixed arms	+\$219
H	height-adjustable arms	+\$339
A	height-adjustable plus pivot arms	+\$448
D	fully adjustable arms	+\$481

Step 3. Armpad Upholstery

WO	nonupholstered armpads	+\$0
FO	leather armpads	+\$102

Step 4. Frame Finish

BK	black A	+\$28
G1	graphite A	+\$0
CRB	carbon A	+\$12
VPR	mineral A	+\$44
ZB	graphite with graphite applique A	+\$56

Step 5. Chassis Finish

For graphite (G1)

G1	graphite A	+\$0
CD	polished aluminum A	+\$21

For carbon (CRB)

SNC	satin carbon A	+\$0
CD	polished aluminum A	+\$21

For mineral (VPR)

SNA	satin aluminum A	+\$0
CD	polished aluminum A	+\$21

For graphite with graphite applique (ZB)

G1	graphite A	+\$0
CD	polished aluminum A	+\$21

For black (BK)

BLX	onyx ultra matte	+\$0
CD	polished aluminum	+\$21

Step 6. Armpad Finish

For nonupholstered armpads (WO) with carbon (CRB)

DCR	dark carbon A	+\$0
------------	---	------

New Aeron® Accessories

Arm Kit *continued*

For nonupholstered armpads (W0) with mineral (VPR)

DVP dark mineral A +\$0

For nonupholstered armpads (W0) with black (BK), or graphite (G1), or graphite with graphite applique (ZB)

BK black A +\$0

Step 7. Armpad Leather

For leather armpads (F0)

See application chart and textiles list for fabric usage and numbers.

First 2 digits of number indicate fabric line; remaining digit(s) indicate fabric color.

Price Category 7 A +\$0

Price Category 9 A +\$75

Lumbar Kit

AER900NN



Product Information

Description

This lumbar support fits into the back of a new Aeron® work chair to further support the back. The support can be adjusted up and down while providing support to the lumbar region of the spine.

Graphite (G1) finish is recommended for use with the following frame finishes:

- Graphite (G1)
- Graphite with graphite applique (ZB)

Carbon (CRB) finish is recommended for use with carbon (CRB) frame finish.

Mineral (VPR) finish is recommended for use with mineral (VPR) frame finish.

Dimensions

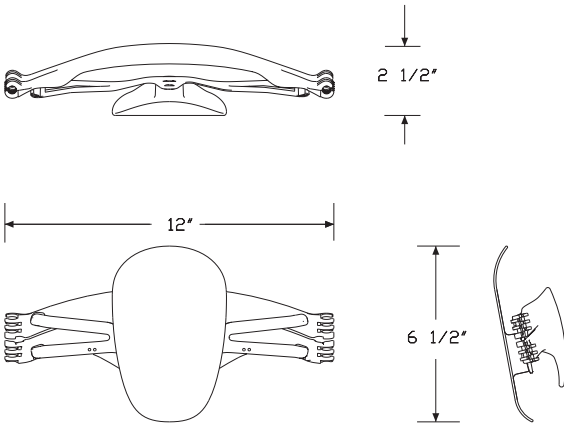

Specification Information

Step 1.

AER900NN A

Step 2. Size

A	a size	+\$118
B	b size	+\$118
C	c size	+\$118

Step 3. Finish

BK	black <input type="checkbox"/> A	+\$18
G1	graphite <input type="checkbox"/> A	+\$0
CRB	carbon <input type="checkbox"/> A	+\$9
VPR	mineral <input type="checkbox"/> A	+\$26

New Aeron® Accessories

Arm Pad Set

AER901

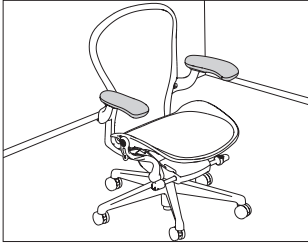

New Aeron® Accessories

Product Information

Description

These Aeron® arm pads are I-skin covered urethane foam molded over a nylon insert. They come in a choice of 3 colors. Arm pads can be retrofitted to a new Aeron work chair. Sold in pairs.

Notes

Black arm pads are recommended for Aeron chairs with a graphite (G1) frame.

Dark carbon arm pads are recommended for Aeron chairs with a carbon (CRB) frame.

Dark mineral arm pads are recommended for Aeron chairs with a mineral (VPR) frame.

Customer's Own Leather (COL) requires 4 square feet. See Order Information in Appendices.

Dimensions

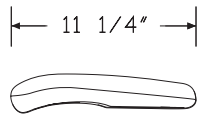
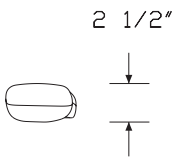
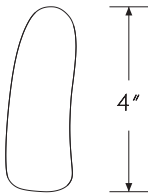

Specification Information

Step 1.

AER901 A

Step 2. Armpad Upholstery

W0	nonupholstered arm pads	+ \$70
F0	leather arm pads	+ \$171

Step 3. Armpad Finish

For nonupholstered arm pads (W0)

BK	black	+ \$0
DCR	dark carbon	+ \$10
DVP	dark mineral	+ \$15

Step 4. Armpad Leather

For leather arm pads (F0)

See application chart and textiles list for fabric usage and numbers.

First 2 digits of number indicate fabric line; remaining digit(s) indicate fabric color.

Price Category 7	+ \$0
Price Category 9	+ \$75



Product Information

Description

This PostureFit® support fits on the back of an A, B, or C size new Aeron® work chair. It provides support in the lower back area, or sacrum, that helps achieve healthier posture and improves lower back comfort.

Graphite (G1) finish is recommended for use with the following frame finishes:

- Graphite (G1)
- Graphite with graphite applique (ZB)

Carbon (CRB) finish is recommended for use with carbon (CRB) frame finish.

Mineral (VPR) finish is recommended for use with mineral (VPR) frame finish.

Dimensions

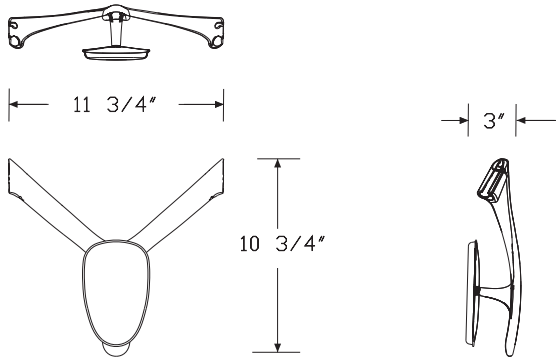

Specification Information

Step 1.

AER905 A

Step 2. Size

A	a size	+\$84
B	b size	+\$84
C	c size	+\$84

Step 3. Finish

BK	black <input type="checkbox"/> A	+\$18
G1	graphite <input type="checkbox"/> A	+\$0
CRB	carbon <input type="checkbox"/> A	+\$10
VPR	mineral <input type="checkbox"/> A	+\$26



New Aeron® Accessories

Product Information

Description

This adjustable PostureFit® SL support fits on the back of an A, B, or C size new Aeron® work chair. It provides custom, adjustable support in the lower back area, or sacrum, that helps achieve healthier posture and improves lower back comfort. Adjustable PostureFit SL also provides support in the lumbar region of the spine. User can adjust the level of support by dialing the support in or out. Adjustable PostureFit SL ships with the support and includes a new backrest.

This requires an installer to modify the existing chair.

Graphite (G1) finish is recommended for use with the following frame finishes:

- Graphite (G1)
- Graphite with graphite applique (ZB)

Carbon (CRB) finish is recommended for use with carbon (CRB) frame finish.

Mineral (VPR) finish is recommended for use with mineral (VPR) frame finish.

Dimensions

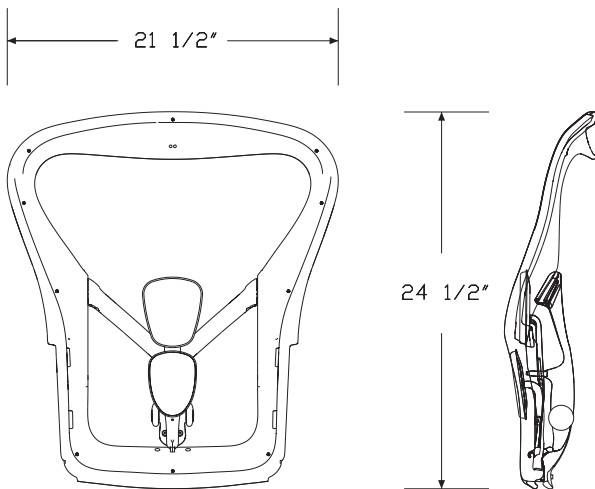

Specification Information

Step 1.

AER906 [A]

Step 2. Size

A	a size	+\$372
B	b size	+\$372
C	c size	+\$372

Step 3. Frame Finish

For a size (A) or b size (B)

BK	black [A]	+\$30
G1	graphite [A]	+\$0
CRB	carbon [A]	+\$16
VPR	mineral [A]	+\$44
ZB	graphite with graphite applique [A]	+\$80

For c size (C)

BK	black [A]	+\$30
G1	graphite [A]	+\$0
CRB	carbon [A]	+\$16
VPR	mineral [A]	+\$44
ZB	graphite with graphite applique [A]	+\$80

Step 4. 8Z Pellicle

For graphite (G1) or graphite with graphite applique (ZB)

Price Category 1 [A]	+\$0
----------------------	------

For mineral (VPR)

Price Category 1 [A]	+\$0
----------------------	------

For carbon (CRB)

Price Category 1 [A]	+\$0
----------------------	------

For black (BK)

Price Category 1 [A]	+\$0
----------------------	------

Frame Applique

AER910



Product Information

Description

This frame applique is applied to a new Aeron® work chair's seat, back, and arms to minimize the effect of contact between the chair and a wood-edge surface. The seat and back appliques attach with the chair's existing screws. Coated arm yokes replace existing arm yokes. Arm components are preassembled. The arm yokes use the chair's existing armpads.

Dimensions

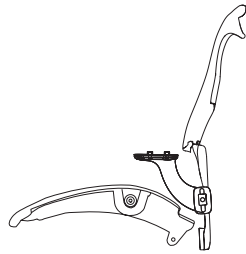
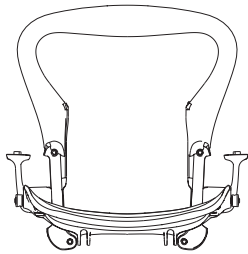

Specification Information

Step 1.

AER910 A

Step 2. Arms

P	fixed arms	+\$820
H	height-adjustable arms	+\$838
A	height-adjustable plus pivot arms	+\$852
D	fully adjustable arms	+\$873

Step 3. Size

A	a size	+\$0
B	b size	+\$0
C	c size	+\$0

Step 4. Finish

ZB	graphite with graphite applique	<input type="checkbox"/> A	+\$0
-----------	---------------------------------	----------------------------	------

New Aeron® Accessories

Index by Product Name

New Aeron® Chairs	
Arm Kit	page(s) 17
Arm Pad Set	20
Frame Applique	23
Lumbar Kit	19
PostureFit® SL	22
PostureFit® Support	21
Work Chair	5
Work Chair, Ready to Assemble	9
Work Stool	13



Index by Product Number

AER1A Work Chair	page(s) 5
AER1B	
AER1C	
AER2A Work Chair, Ready to Assemble	9
AER2B	
AER2C	
AER71 Work Stool	13
AER72	
AER900 Arm Kit	17
AER900NN Lumbar Kit	19
AER901 Arm Pad Set	20
AER905 PostureFit® Support	21
AER906 PostureFit® SL	22
AER910 Frame Applique	23





20-Day or Less/Assigned Lead-Time Order Information

GSA

20-Day or Less and Assigned Lead-Time Programs

20-day or less and assigned lead-time products are designed for established Herman Miller dealers with pre-approved credit.

Products are distributed from multiple manufacturing facilities across the United States. All products and options not designated by an Assigned Lead-Time icon  will ship in 20 business days or less after being acknowledged by Herman Miller. Products and options designated by an  are on the assigned lead-time program and will ship in 20 days, less than 20 days, or more than 20 days from order acknowledgement.

Ordering Procedure

Please place orders through Order Manager. If this is not available to you, place orders through mail or fax. Verbal purchase orders will not be accepted.

Order Entry fax number for Meridian® Filing and Storage:

(616) 846 9236.

Order Entry fax number for all other products:

(616) 654 3085.

For more information, contact your Customer Care representative at:

(866) 854 3048 ext 3400.

Shipments and Delivery

Per Herman Miller Terms and Conditions.

Changes and Cancellation

Per Herman Miller Terms and Conditions.



Size/Fit Reference — New Aeron® Chair

GSA

This reference helps people select A-, B-, or C-size chairs when the three sizes are not available for actual test sitting. Height and weight are key indicators of suitable chair-size choice. Since the B-size chair is designed to fit a broad range of people, Herman Miller recommends it for users who fall in the A/B or B/C category. This chart applies to New Aeron chairs with the extended-height-range pneumatic height-adjustment cylinder.

To determine which chair size is best, find the point of intersection for your height and weight. New Aeron B-, and C-size chairs are tested and warranted for use by persons 350 pounds and under. A-size chairs are tested and warranted for use by persons 300 pounds and under.

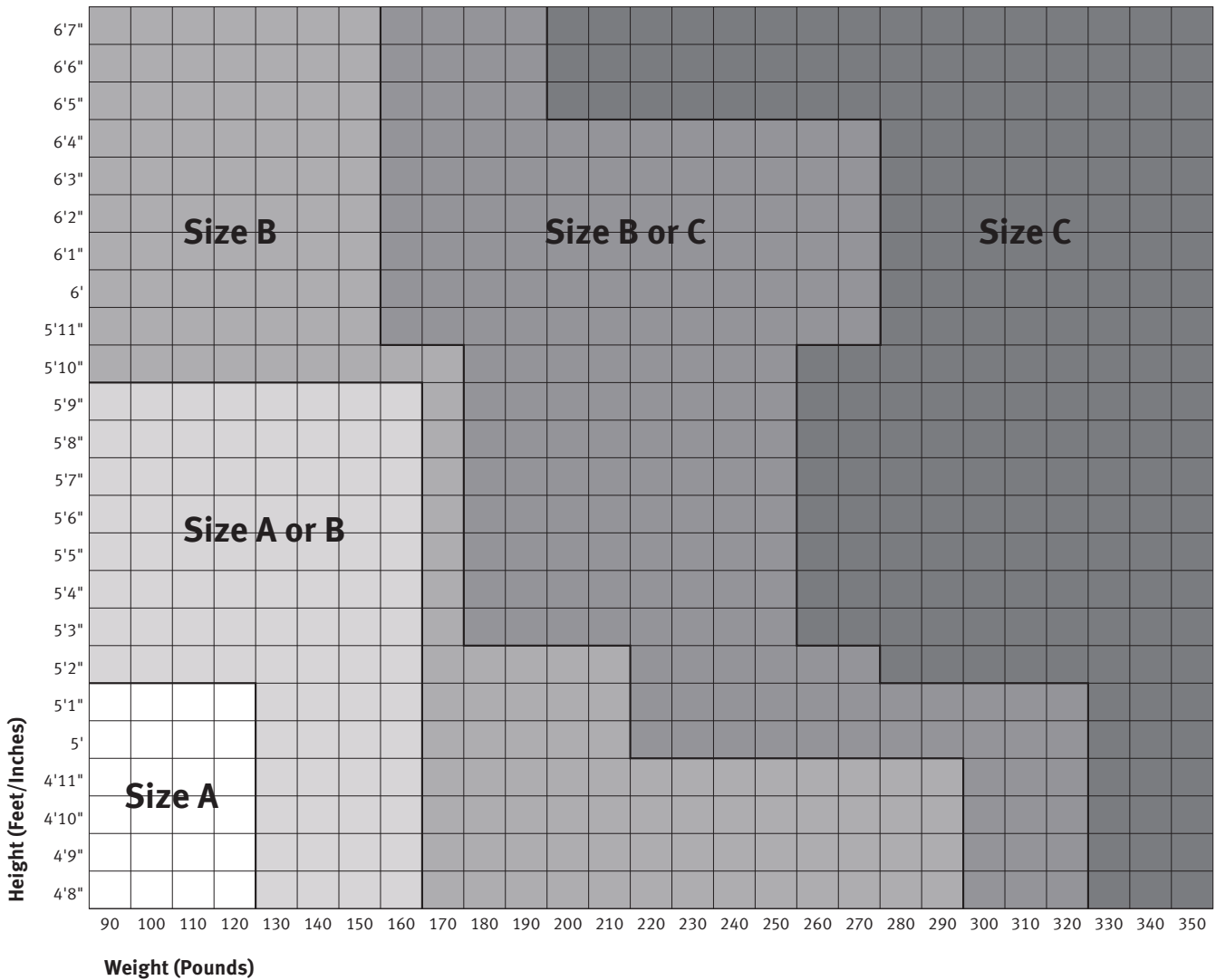



Casters and Glides

GSA

⚠	WARNING	⚠
Depending on the floor surface, chair may unexpectedly roll away from user when entering or exiting the chair, possibly leading to unexpected injury. Please refer to descriptions of floor types when selecting casters.		

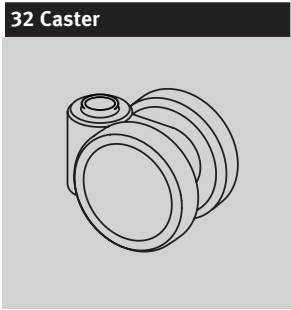

32 Caster
 1 7/8-inch-diameter hard double-wheel caster; black nylon wheels and yoke; for use on carpet only
 Applicable on:
 Sayl® Chairs

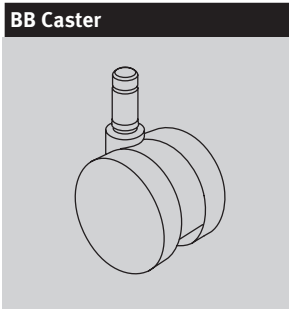

BB Caster
 2 1/2-inch-diameter hard double-wheel caster; black nylon wheels and yoke; for use on carpet only
 Applicable on:
 New Aeron® Chairs
 Caper® Chairs
 Embody® Chairs
 Equa 2® Chairs
 Ergon 3® Chairs
 Lino™ Chairs
 Mirra® 2 Chairs
 Sayl Chairs Verus™ Chairs

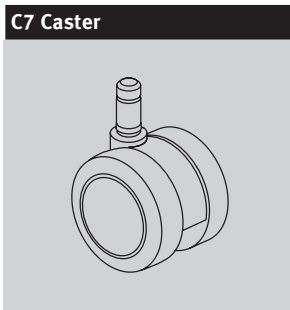

C7 Caster
 2 1/2-inch-diameter double-wheel caster; black nylon wheels and yoke; soft polyurethane tread; for use on hard floors or carpet
 Applicable on:
 New Aeron Chairs
 Caper Chairs
 Embody Chairs
 Equa 2 Chairs
 Ergon 3 Chairs
 Lino Chairs
 Mirra 2 Chairs
 Sayl Chairs Verus Chairs

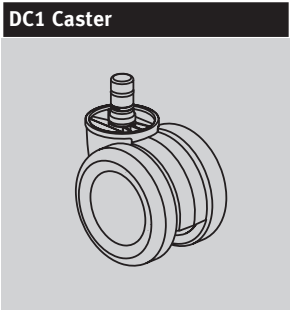

DC1 Caster
 2 1/2-inch-diameter double-wheel braking caster; black nylon wheels and yoke; quiet roll technology
 Applicable on:
 New Aeron Chairs

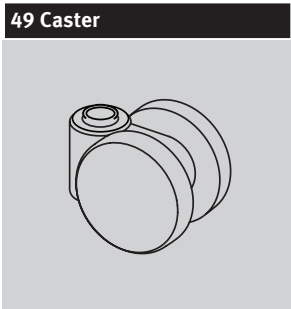

49 Caster
 1 7/8-inch-diameter soft double-wheel caster; black nylon wheels and yoke; for use on hard floors or carpet
 Applicable on:
 Sayl Chairs



BKS Caster
 2 1/2-inch-diameter hard double-wheel caster; black yoke; quiet roll technology; for use on carpet only
 Applicable on:
 Cosm™ Chairs

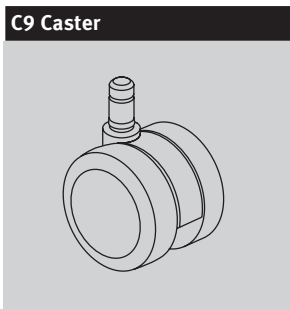

C9 Caster
 2 1/2-inch-diameter double-wheel caster; black nylon wheels and yoke; soft polyurethane tread; internal brake; for use on hard floors or carpet
 Applicable on:
 Caper Chairs
 Embody Chairs
 Equa 2 Chairs Mirra 2 Chairs
 Ergon 3 Chairs Sayl Chairs
 Keyn Chairs Setu Chairs
 Lino Chairs Verus Chairs

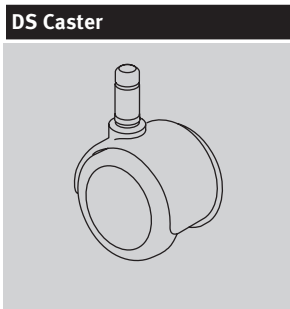

DS Caster
 2-inch-diameter soft double-wheel braking caster; black nylon wheels and hood; for use on hard floors only
 Applicable on:
 Aside® Chairs
 Caper Chairs

Casters and Glides

continued

GSA

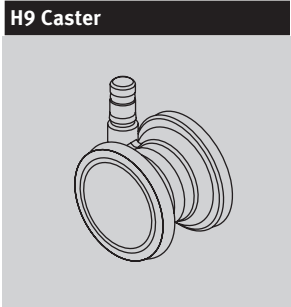

2¹/₂-inch-diameter double-wheel caster; clear polycarbonate wheels; nylon yoke; soft polyurethane tread; for use on carpet only.
Applicable on:
Embody Chairs

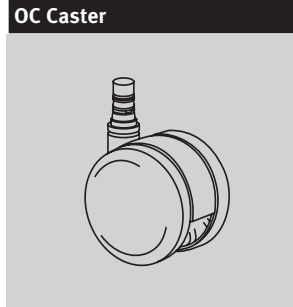

2¹/₂-inch-diameter double-wheel medium roll-resistant caster; black nylon wheels and yoke; soft polyurethane tread; for use on hard floors or carpet; quiet roll technology
Applicable on:
Cosm Chairs
Keyn Chairs
Setu Chairs

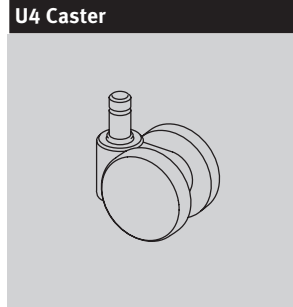

1⁷/₈-inch-diameter hard double-wheel caster; black nylon wheels and yoke; for use on carpet only
Applicable on:
Aside Chairs
Verus Chairs



(Front glide shown)
2¹/₈-inch-high glide; black or fog acetal; for use on carpet only
Applicable on:
Sayl Chairs

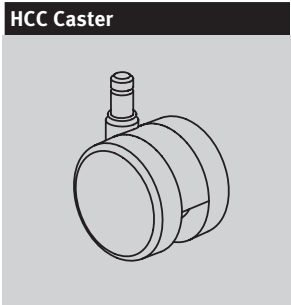

2¹/₂-inch-diameter double-wheel low roll resistance caster; black yoke; for use on hard floors or carpet.
Applicable on:
Keyn Chairs
Setu Chairs



2¹/₂-inch-diameter double-wheel caster; black nylon wheels and yoke; soft polyurethane tread; quiet roll technology; for use on hard floors or carpet
Applicable on:
Cosm Chairs
Lino Chairs
Mirra 2 Chairs
Verus Chairs

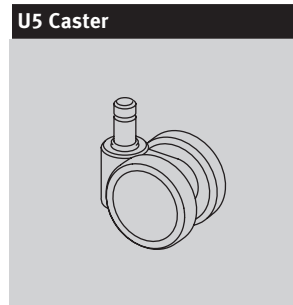

1⁷/₈-inch-diameter soft double-wheel caster; black nylon wheels and yoke; for use on hard floors or carpet
Applicable on:
Aside Chairs
Caper Chairs
Verus Chairs

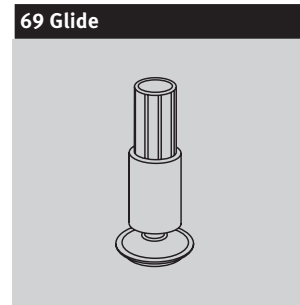

(Front glide shown)
2¹/₈-inch-high glide; black glass-filled nylon stem; steel-plated swivel foot with Floor Saver Glide® insert; for use on hard floors only
Applicable on:
Sayl Chairs

Casters and Glides

continued

GSA



G4 Glide

1⁷/₈-inch-high glide; black acetal; for use on carpet only
Applicable on:
Verus Chairs



GL Glide

1⁷/₈-inch-high glide; black nylon stem; steel-plated swivel foot with Floor Saver Glide® insert; for use on hard floors only
Applicable on:
Verus Chairs

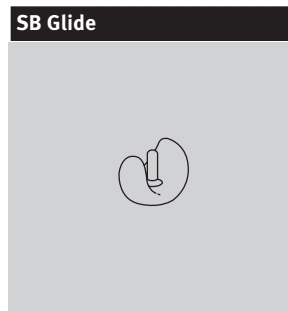

SB Glide

1/4-inch-high, 1-inch diameter glide; thermoplastic CAP material (G1 base has black glides; XT base has clear glides); for use on hard floors or carpet
Applicable on:
Equa 2 Chairs

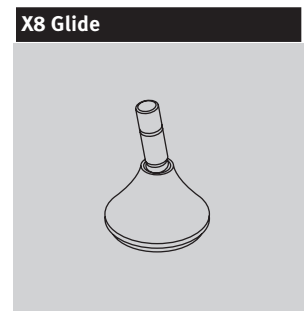

X8 Glide

Glide; low profile; for use on hard floors or carpet
Applicable on:
Setu Chairs



GF Glide

2¹/₂-inch-high glide; black nylon; for use on hard floors or carpet
Applicable on:
New Aeron Chairs
Caper Chairs
Cosm Chairs
Equa 2 Chairs
Ergon 3 Chairs
Lino Chairs
Mirra 2 Chairs
Sayl Chairs
Verus Chairs



HG Glide

1/2-inch-high glide; black nylon glide with stainless-steel insert; for use on hard floors or carpet
Applicable on:
Aside Chairs



SG Glide (for Aside)

1/2-inch-high glide; black nylon; for use on carpet only
Applicable on:
Aside Chairs

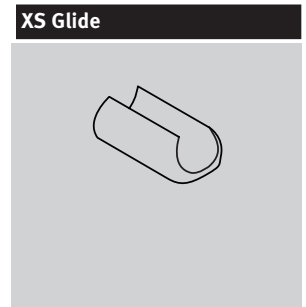

XS Glide

1/8-inch-high glide; polycarbonate in black, fog, clear, and studio white finishes; for use on hard floors or carpet
Applicable on:
Sayl Chairs

Casters and Glides

continued

GSA

Y7 Glide

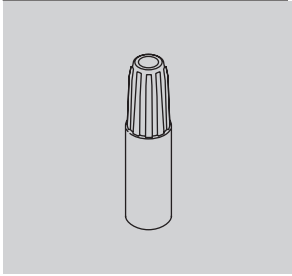

1 7/8-inch-high glide; black acetal; for use on carpet only

Applicable on:

Caper Chairs

YX Glide

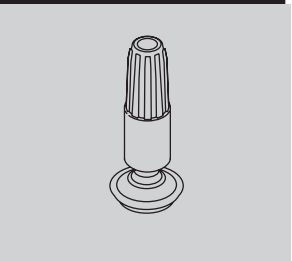

1 7/8-inch-high glide; black nylon stem; steel-plated swivel foot with Floor Saver Glide® insert; for use on hard floors only

Applicable on:

Caper Chairs

Fire Retardancy — Seating

GSA

Fire Retardancy

Fire-retardant chairs manufactured in approved fabrics (FR) meet California TB 133 requirements.

All foam and textiles on HermanMiller seating products comply with California TB 117-2013.

State of California
Bureau of Home Furnishings,
Technical Bulletin 133

State of California
Bureau of Home Furnishings,
Technical Bulletin 117-2013

8Z Pellicle		•
AireWeave™ 2		•
Balance		•
Bento		•
Bingo		•
Crepe		•
Crossing		•
Dex		•
Duo		•
Flexnet™	FR	•
Gem		•
Hopsak		•
Intercept		•
InterWeave		•
Latitude™		•
Leather		•
Loom		•
Lyrus 2™		•
Marvel		•
Medley		•
Mercer		•
Moiré		•
Monologue		•
Plateau		•
Quilty		•
Rhythm		•
Rivet		•
Sequel		•
Spools		•
Stitches		•
Strata		•
Twist		•
Whisper		•

• Fabric meets California TB 117-2013 code requirements.

FR To meet California TB 133 code requirements, fabrics must be applied to approved chairs identified with FR product numbers.



Customer's Own Material/Customer's Own Leather Order Information — Seating

GSA

Packaging

Packaging varies according to individual product. A surcharge may be added for special packaging requests. Contact Customer Care for specific information.

Customer's Own Material/Customer's Own Leather

Program Overview

The Customer's Own Material (COM) and Customer's Own Leather (COL) program gives you the option of using textiles other than those listed. Herman Miller will test textiles for application to Herman Miller products and will process orders for those with approved COM/COL textiles only. COM/COL are assigned lead-time textiles.

Omni lists an overview of fabrics and leathers that have been tested and indicates whether or not they were approved for application to Herman Miller products.

Specific information on the terms and conditions, testing, approval, and ordering process for COM/COL is listed below. Questions about the COM/COL program and requests for assistance may be directed to your COM representative at:

(616) 654 3400

(866) 854 3048 ext 6543400

Customer's Own Material/Customer's Own Leather Warranty

Herman Miller does not warrant COM/COL textiles. COM/COL textiles are tested for application only; they are not tested for performance. The Herman Miller warranty does apply to the underlying products.

Suppliers of COM/COL textiles are responsible for color consistency within commercial tolerances, UV stability, and resistance to soiling and perspiration.

Customer's Own Material/Customer's Own Leather Pricing

COM is a Category 1 fabric. There are no application charges for COM fabrics. COL is a Category 7 textile; refer to prices on specific products to determine the application charge.

Ordering and payment for COM/COL textile yardage are the responsibility of the customer and the textile supplier.

If desired, Herman Miller will purchase COM textiles directly from Maharam, Camira, C.F. Stinson, Guilford of Maine, Luna Textiles, Momentum Textiles and Ultrafabrics to simplify ordering and shipment. For this service, refer to the Supplier Connection program.

Customer's Own Material/Customer's Own Leather Order Information — Seating

continued

GSA

Textile Approval

1. Select a COM textile and a Herman Miller product.
2. If your textile does not show as tested in Omni, submit a request. You will be required to select a specific color of the textile and feature of the product to test, i.e., seat, back, etc.
3. Herman Miller will notify you of approval or disapproval within 4 days from receipt of the test yardage.

Ordering Products with COM/COL

1. Refer to the specific products to determine the yardage required for COM/COL textiles.
Note: Additional yardage may be needed due to the unique characteristics of a textile.
2. Obtain the COM ID# in Omni. If the color you are ordering does not have a COM ID# assigned, click "Create ID".
3. Enter your order on Order Manager in Omni.
4. Upon receipt of your purchase order, Herman Miller will send you a PO acknowledgment.
5. Arrangements must be made for the textiles to be shipped from the supplier to Herman Miller for application to the seating products. Textiles must be tagged with the assigned identification number and the roll yardage quantity. See Omni for shipping procedures and current shipping addresses or contact a COM representative at (616) 654 3400 or (866) 854 3048 ext 6543400.

Products will be scheduled for production when COM/COL textiles are received at Herman Miller. Standard lead times in effect at that time will apply.

Note: If textiles are to be purchased directly by Herman Miller through the Supplier Connection program, Herman Miller will handle the ordering and shipping process and will schedule your order for production upon receipt of your purchase order (dependent on textile availability). Refer to the Supplier Connection program for more information.

Supplier Connection

Program Overview

The Supplier Connection program is a service offered by Herman Miller to purchase approved COM textiles directly from Maharam, Camira, C.F. Stinson, Guilford of Maine, Luna Textiles, Momentum Textiles and Ultrafabrics. When you select a textile through this program, Herman Miller will facilitate the ordering, scheduling, and shipment of the textile directly with the supplier.

Suppliers included in the Supplier Connection program keep an active inventory of textiles that are pre-approved for application to Herman Miller products. Pre-approval applies only to the suitability of a textile for manufacturing and application to a Herman Miller product. Omni provides an overview of fabrics that have been tested and indicates whether or not they were approved for application to Herman Miller products.

Specific information on the terms and conditions, testing, approval, and ordering process for the Supplier Connection program is listed below. Questions and requests for assistance may be directed to your COM representative at:

(616) 654 3400

(866) 854 3048 ext 6543400

Supplier Connection Warranty

Textiles purchased by Herman Miller through the Supplier Connection program are COM and are not warranted by Herman Miller. COM textiles are tested for application only; they are not tested for performance. The Herman Miller warranty does apply to the underlying products.

Suppliers of COM textiles are responsible for color consistency within commercial tolerances, UV stability, and resistance to soiling and perspiration.

Customer's Own Material/Customer's Own Leather Order Information — Seating

continued

GSA

Supplier Connection Pricing

Textiles purchased by Herman Miller through the Supplier Connection program are COM. COM is a Category 1 fabric. There are no application charges for COM fabrics.

Payment for textiles purchased by Herman Miller through the Supplier Connection program is the responsibility of the customer or dealer. Herman Miller will invoice the order at the suppliers prices published at the time of the order.

Textile Approval

1. Select a COM textile and a Herman Miller product.
2. If your textile does not show as tested in Omni, submit a request. You will be required to select a specific color of the textile and feature of the product to test, i.e., seat, back, etc.
3. Herman Miller will notify you of approval or disapproval within 4 days from receipt of the test yardage.

Ordering Products with Supplier Connection COM

1. Identify and include the following information on your purchase order:
 - Product number and option
 - Herman Miller's COM identification number
2. Enter your order on Order Manager in Omni.
3. Upon receipt of the purchase order, Herman Miller will process your order and send you a PO acknowledgment. Herman Miller will determine the yardage required to produce your product and will order and schedule for delivery the required textile. Standard lead times in effect at the time the textile is allocated at the supplier will apply to products ordered through this program.



Proprietary Textiles Application Chart – Seating

GSA

- Available

[A] Assigned lead-time textile.
See following page for exception notes.

[N] Non-woven textile.

	Aeron® Chairs	Cosm™ Chairs	Mirra® 2 Chairs/Stools	Embody® Chairs	Sayl® Work Chairs/Stools	Sayl Side Chairs	Setu® Chairs/Stools	Setu Lounge Chair/Ottoman	Verus™ Work Chairs/Stools Back	Verus Work Chairs/Stools Seat	Verus Side Chairs Back	Verus Side Chairs Seat	Verus Plus Chairs	Aside® Chairs	Caper® Chairs/Stools	Keyn Chair Group Back	Keyn Chair Group Seat	Lino™ Chairs Back	Lino Chairs Seat	OE1 Storage Trolley Cushion Top	Public® Office Landscape Back	Public Office Landscape Seat	Plex™ Lounge Furniture	Swoop™ Lounge Seating - Fully Upholstered	Swoop Lounge Seating - Plywood	Valor™ Seating	Nemschoff® Whisk™ Chairs	Cushion Tops	Workspaces	
Price Category 1																														
COM Customer's Own Material [A]					1	1			1	1	1	1	1	1			1		1	1			1	1	1		1	1	1	
231__ 8Z Pellicle®	•																													
1A7__ AireWeave 2			•																											
8T__ Crossing							•	•																						
3DE__ Dex					•	•			•	•	•	•	•	•										•	•	•	•	•	•	
4RM__ Duo																			•											
6V__ Flexnet™																•														
95__ Gem								•	•													•		•	•				•	•
845__ Intercept			•																											
65__ Interweave									•			•																		
4W__ Lyris 2™								•	•																					
1MN__ Monologue					24	22	•	•		•	•	•	•	•			•	•		•	•		•	•	•	•	•	•	•	
4SC__ Scatter					•	•	•		•	•	•	•	•	•			•	•		•	•		•	•	•	•	•	•	•	
3DK__ Stretch Knit					21																									
235__ Tailored					•	•	•	•	•	•	•	•	•	•	•	•	•	•	•	•	•		•	•	•	•	•	•	•	
1WS__ Whisper					24	•	•	•	•	•	•	•	•	•	•	•	•	•	•	•	•		•	•	•	•	•	•	•	
Price Category 2																														
3AR__ Aristo					•	•	•	•	•	•	•	•	•	•	•	•	•	•	•	•	•	•	•	•	•	•	•	•	•	
92__ Crepe					•	•	•	•	•	•	•	•	•	•	•	•	•	•	•	•	•	•	•	•	•	•	•	•	•	
3EP__ Epic					•	•	•		•	•	•	•	•	•			•	•		•	•		•	•	•	•	•	•	•	
1LM__ Loom					•	•			•	•	•	•	•			•	•		•	•		•		•	•	•	•	•	•	
1MV__ Marvel [N]					21	22										•				•										
1HA__ Medley					•	•	22		•	•	•	•	•	•	•	•	•	•	•	•	•	•	•	•	•	•	•	•	•	
4ME__ Mellow					•	22	•	•	•	•	•	•	•	•	•	•	•	•	•	•	•	•	•	•	•	•	•	•	•	
30__ Rhythm					23	•	•		•	•	•	•	•	•	•	•	•	•	•	•	•	•	•	•	•	•	•	•	•	
1RV__ Rivet																														
3SL__ Sequel [N]					•	•	•	•	•	•	•	•	•	•	•	•	•	•	•	•	•	•	•	•	•	•	•	•	•	
4TE__ Terra					•	22			•	•	•	•	•	•	•	•	•	•	•	•	•	•	•	•	•	•	•	•	•	
8R__ Twist					•	•	•	•	•	•	•	•	•	•	•	•	•	•	•	•	•	•	•	•	•	•	•	•	•	
Price Category 3																														
3AC__ Ace					21	•			•	•	•	•	•	•	8	•	•		•	•		•	•	•	•	•	•	•		
8M__ Latitude™					23	•	•																	•	•					
22V__ String Plaid					•	•			•	•	•	•	•	•									•							
Price Category 4																														
3DM__ Daydream					21	•	•	•		•		•	•	•			•		•	•			•	•	•			•	•	
213__ Mercer					21	22			•	•	•	•	•			•	•		•	•		•		•	•	•	•	•	•	
1A9__ Network																						•								
6S__ Quilty					•	•			•	•	•	•	•	•			•	•		•	•			•			•	•	•	
22P__ Strata					•	•	•		•	•	•	•	•	•	•	•	•	•	•	•	•	•	•	•	•	•	•	•	•	
3SY__ Sync					•	•	•	•	•	•	•	•	•	•	•	•	•	•	•	•	•	•	•	•	•	•	•	•	•	

Continued on next page

Proprietary Textile Colors — Seating

GSA

Price Category 1

Customer's Own Material
See Order Information in Appendices.
Assigned lead-time textile. A

8Z Pellicle®
For New Aeron® Chairs
56% elastomeric
44% polyester
23101 Mineral
23102 Carbon
23103 Graphite

AireWeave™ 2
For Mirra® 2 Chairs
67% elastomeric
33% antimony-free polyester
1A701 Alpine
1A702 Slate Grey
1A703 Graphite
1A704 Lime Green
1A705 Cappuccino
1A706 Urban Orange
1A707 Dark Turquoise
1A708 Twilight

Crossing
54" wide
86% antimony-free polyester
14% polyester
8T03 Wicker
8T04 Porcelain
8T05 Warm Grey
8T06 Sepia
8T07 Pumpkin
8T08 Copper
8T09 Cranberry
8T10 Tomato
8T11 Mulberry
8T12 Plum
8T13 Green Apple
8T14 Loden
8T15 Spruce
8T16 Periwinkle
8T17 Cerulean
8T18 Indigo
8T19 Shale
8T20 Brownstone
8T21 Bark
8T22 Tin
8T23 Graphite
8T24 Black

Dex
54" wide
50% recycled polyester
50% polyester
3DE01 Frost
3DE02 Silver Pine
3DE03 Stone
3DE04 Shale
3DE05 Charcoal

Duo
For Lino™ Chairs
52% polyester
48% elastomeric
4RM01 Mineral
4RM02 Poppy
4RM03 Green Leaf
4RM04 Jade
4RM05 Shadow
4RM06 Graphite

Flexnet™
For Caper® Chairs
69% elastomeric
31% polyester
6V01 Black
6V02 Silver Grey

Gem
54" wide
100% antimony-free polyester
9502 Tangerine
9503 Red
9507 Twilight
9508 Bayou
9510 Berry Blue
9511 Aqua Green
9512 Green Apple
9514 Black
9515 Slate Grey
9516 Fog

Interweave
For Verus™ Chairs
71% elastomeric
29% polyester
6504 Pewter
6505 Charcoal
6506 Black

Lyris 2™
For Setu® Chairs
74% elastomeric
26% polyester
4W21 Alpine
4W22 Mango
4W23 Chartreuse
4W25 Berry Blue
4W26 Slate Grey
4W28 Chino
4W29 Rattan
4W30 Java
4W31 Graphite

Monologue
54" wide
56% recycled polyester
44% polyester
1MN01 Linen
1MN02 Alabaster
1MN03 Truffle
1MN04 Folkstone
1MN05 Silver Pine
1MN06 Slate
1MN07 Seed
1MN08 Yellow Oxide
1MN09 Persimmon
1MN10 Tundra
1MN11 Meadow
1MN12 Blue Sky
1MN13 Blue Spruce
1MN14 Deep Sea

Scatter
54" wide
100% recycled polyester,
with 26% ocean bound plastic
4SC01 Alpine
4SC02 Fog
4SC03 Shale
4SC04 Persimmon
4SC05 Red Violet
4SC06 Lime Zest
4SC07 Olive
4SC08 Glacier
4SC09 Blue Sky
4SC10 Lagoon
4SC11 Slate Grey
4SC12 Blue Black

Price category 1 continued on next page

Proprietary Textile Colors — Seating

continued

GSA

Price Category 1

continued

Appendix: Proprietary Textile Colors — Seating

Stretch Knit	
Assigned lead-time textile. A	
Available only on Sayl®	
Suspension Back Work Chairs	
97% polyester, 3% spandex	
3DK01	Fog
3DK02	Slate Grey
3DK03	Java
3DK04	Black
3DK05	Red
3DK06	Green Apple
3DK07	Berry Blue

Tailored	
54" wide	
56% polyester	
44% recycled polyester	
23501	Studio White *
23502	Sugar *
23503	Tomato
23504	Orchid
23505	Boysenberry
23506	Chive
23507	Bluegrass
23508	Cobalt
23509	Cadet
23510	Fog
23511	Graphite
23512	Black
23513	Coffee

* Colors not available on Plex™ Lounge Furniture.

Whisper	
54" wide	
73% recycled polyester	
27% polyester	
1WS01	Sand Dollar
1WS02	Pebble
1WS03	Silver Birch
1WS04	Iceberg
1WS05	Silver Pine
1WS06	Carbon
1WS07	Cumin
1WS08	Adobe
1WS09	Strawberry
1WS10	Blush
1WS11	Eggplant
1WS12	Willow
1WS13	Sea Grass
1WS14	Pool
1WS15	Blueberry

Price Category 2

Aristo	
54" wide	
88% recycled polyester	
12% polyester	
Acrylic backing	
3AR01	Forest Moss
3AR02	Light Brindle
3AR03	Mink
3AR04	Copper
3AR05	Adobe
3AR06	Cherry
3AR07	Lilac
3AR08	Green Apple
3AR09	Surf
3AR10	Waterfall
3AR11	Cadet
3AR12	Tin
3AR13	Pewter
3AR14	Grey Brindle
3AR15	Grey Black

Crepe	
54" wide	
100% recycled polyester	
9201	Licorice
9203	Smoke
9207	Cherry
9209	Claret
9212	Raisin
9218	Aquamarine
9223	Cadet
9241	Beachglass
9243	Midnight
9244	Artichoke
9248	Warm White
9249	Stone
9250	Earth
9251	Fog
9252	Slate Grey

Crepe continued	
9253	Yellow Dark
9254	Coral
9255	Blush Grey
9256	Wild Berry
9257	Clover
9258	Caribbean
9259	Cerulean
9260	Brownstone
9261	Shale
9262	Graphite
9263	Tomato
9264	Green Apple

Epic	
54" wide	
56% recycled polyester	
44% polyester	
Acrylic backing	
3EP01	Alabaster
3EP02	Smoke
3EP03	Falcon
3EP04	Citrus Spring
3EP05	Copper
3EP06	Urban Orange
3EP07	Poppy
3EP08	Wild Plum
3EP09	Sugar Plum
3EP10	Clover
3EP11	Loden
3EP12	Everglade
3EP13	Mist
3EP14	Peacock
3EP15	Cadet
3EP16	Indigo
3EP17	Spring Wood
3EP18	Grey Brindle
3EP19	Seed
3EP20	Carbon Dark

Price category 2 continued on next page

Proprietary Textile Colors — Seating

continued

GSA

Price Category 2

continued

Loom	
54" wide	
100% polyester	
1LM01	Linen *
1LM02	Brown Sugar and Spice
1LM03	Brick and Mortar
1LM04	Salt and Pepper
1LM05	Black
1LM06	Lemongrass
1LM08	Wild Berry
1LM09	Loden
1LM10	Jade
1LM11	Deep Sea

* Color not available on Valor Seating

Mellow	
54" wide	
100% recycled polyester, with 16% ocean bound plastic	
4ME01	Mineral
4ME02	Pewter
4ME03	Wisteria
4ME04	Olive
4ME05	Glacier
4ME06	Oceanside
4ME07	Charcoal

Marvel	
54" wide	
100% pvc-free polyurethane	
1MV01	Summer White
1MV02	Sand Dollar
1MV03	Espresso
1MV04	Folkstone Grey
1MV05	Graphite
1MV06	Onyx
1MV07	Polar Blue
1MV08	Blush Grey
1MV09	Woodrose
1MV10	Citrus
1MV11	Adobe
1MV12	Red
1MV13	Kiwi Green
1MV14	Pine
1MV15	Teal Green
1MV16	Twilight

Medley	
54" wide	
100% polyester	
1HA01	Stone
1HA02	Trail
1HA03	Charcoal
1HA04	Cinder
1HA05	Citrus
1HA06	Papaya
1HA07	Chutney
1HA08	Tundra
1HA09	Feather Grey
1HA10	Chartreuse
1HA11	Loden
1HA12	Peacock
1HA13	Bayou
1HA14	Blue Grotto
1HA15	Blueberry
1HA22	Khaki
1HA23	Pewter
1HA24	Yellow Oxide
1HA25	Vintage Rose
1HA26	Raspberry
1HA27	Acai Berry

Rhythm	
54" wide	
100% polyester	
3001	Kiwi Green *
3002	Green Apple *
3003	Peacock *
3004	Bayou *
3005	Berry Blue
3006	Iris *
3007	Twilight
3008	Pumpkin *
3009	Poppy *
3010	Molasses *
3011	Mulberry *
3012	Khaki *
3013	Mink *
3014	Black
3015	Charcoal

* Colors not available on Embody Chair

Rivet	
54" wide	
100% recycled polyester	
1RV01	Twig
1RV02	Deep Clay
1RV03	Woodrose
1RV04	Otter
1RV05	Hemlock
1RV06	Olive
1RV07	Lagoon
1RV08	Deep Sea
1RV09	Charcoal
1RV10	Grey Brindle

Sequel	
54" wide	
100% vinyl	
100% polyester knit backing	
Resilience® finish	
3SL01	White
3SL02	Pebble
3SL03	Mushroom
3SL04	Stone
3SL05	Chestnut
3SL06	Rattan
3SL07	Black Cherry
3SL08	Tundra
3SL09	Seal
3SL10	Blue Fog
3SL11	Folkstone
3SL12	Shale
3SL13	Slate Grey
3SL14	Charcoal
3SL15	Carbon Dark
3SL28	Navy

Terra	
54" wide	
100% post-consumer recycled biodegradable polyester *	
4TE01	Spring Wood
4TE02	Zinc
4TE03	Pine Cone
4TE04	Charcoal

* 1% biodegradation in 1,278 days under ASTM D5511 conditions. No evidence of further degradation.

Twist	
54" wide	
80% antimony-free polyester	
13% recycled polyester	
7% polyester	
8R05	Wicker
8R10	Poppy
8R14	Tin
8R15	Shale
8R16	Graphite
8R17	Birch
8R18	Sepia
8R22	Blueberry
8R23	Green Apple
8R26	Gunmetal
8R27	Cinder
8R28	Citrus
8R29	Pekoe
8R30	Tangerine
8R31	Red Plum
8R32	Wisteria
8R33	Forest
8R34	Jade Dark
8R35	Waterfall
8R36	Midnight Blue
8R37	Carbon Dark

Proprietary Textile Colors — Seating

continued

GSA

Price Category 3

Ace	
54" wide	
100% polyurethane	
Polyester knit backing	
Stain resistant finish	
3AC01	Summer White
3AC02	White Ash
3AC03	Rye
3AC04	Metal
3AC05	Clay
3AC06	Chestnut
3AC07	Citrus
3AC08	Camelback
3AC09	Chipotle
3AC10	Claret
3AC11	Slate Purple
3AC12	Artichoke
3AC13	Sepia Dark
3AC14	Aloe
3AC15	Flint
3AC16	Blue Sky
3AC17	Oceanside
3AC18	Midnight
3AC19	Spring Wood
3AC20	Frost
3AC21	Lead
3AC22	Black

Latitude™	
61" wide	
100% polyester	
8M01	Graphite
8M02	Shadow
8M10	Alpine
8M17	Black
8M21	Slate Grey
8M22	Lime Green
8M23	French Press
8M24	Urban Orange
8M25	Dark Turquoise
8M26	Twilight

String Plaid	
54" wide	
100% recycled polyester	
22V01	Warm White on Khaki
22V02	Mint on Yellow Green
22V03	Mist on Blue Grey
22V04	Sky Blue on Red
22V05	Lime on Magenta
22V06	Bright Green on Green
22V07	Aqua Blue on Cerulean
22V08	Ivory on Black

Price Category 4

Daydream	
54" wide	
48% wool	
41% recycled polyester	
9% nylon	
2% polyester	
3DM01	Rye Grass
3DM02	Silver Birch
3DM03	Pewter
3DM04	Graphite
3DM05	Black
3DM06	Lemongrass
3DM07	Permission
3DM08	Juniper
3DM09	Sea Grass
3DM10	Nightfall

Mercer	
54" wide	
50% solution dyed recycled nylon	
50% solution dyed nylon	
BLOCKaide	
21301	Stone
21303	Cayenne
21305	Pesto
21306	Teal Blue
21307	Ultramarine
21310	Charcoal

Network	
For Public Office Landscape®	
sectional back/social chair.	
knit to size	
100% polyester	
1A901	Warm White
1A902	Fog
1A903	Red
1A904	Wildberry
1A905	Green Apple
1A906	Twilight
1A907	Graphite

Quilty	
56" wide	
100% antimony-free polyester	
GreenShield	
6S03	Khaki
6S04	Straw
6S07	Brick
6S10	Mink
6S11	Green Apple
6S13	Indigo
6S14	Zinc
6S15	Slate
6S16	Beachwood
6S17	Paprika
6S18	Plum
6S19	Juniper
6S20	Grey Black

Strata	
54" wide	
50% solution dyed recycled nylon	
50% solution dyed nylon	
BLOCKaide	
22P04	Pesto
22P05	Peacock
22P06	Blue Jay
22P07	Blueberry
22P09	Mango
22P10	Paprika
22P12	Wheat
22P13	Brownstone
22P14	Bayou

Sync	
55" wide	
100% polyester	
3SY01	Pine Cone
3SY02	Citron
3SY03	Canyon
3SY04	Truffle
3SY05	Wild Berry
3SY06	Everglade
3SY07	Glacier
3SY08	Nightfall
3SY09	Dark Mineral
3SY10	Slate Grey
3SY11	Dark Carbon
3SY12	Black

Proprietary Textile Colors — Seating

continued

GSA

Price Category 5

Cozy

54" wide	
100% wool	
3CY01	Heathered Warm Grey
3CY02	Heathered Rye Grass
3CY03	Heathered Cool Grey
3CY04	Heathered Blue Grey
3CY05	Heathered Black
3CY06	Heathered Persimmon
3CY07	Heathered Loden
3CY08	Heathered Jade
3CY09	Heathered Lagoon
3CY10	Heathered Twilight

Hopsak

56" wide	
100% recycled polyester	
14A20	Black
14A22	Raw Umber Dark
14A26	Grey Blue Dark
14A30	Sepia Dark
14A38	Emerald Dark
14A39	Yellow Dark
14A40	Orange
14A41	Sienna
14A42	Olive Green Dark
14A43	Crimson
14A44	Crimson Dark Dark
14A45	Violet Dark
14A46	Pink Dark Dark
14A47	Ultramarine Dark
14A48	Cobalt Blue
14A49	Terra Cotta
14A50	Ochre Dark

Summit

54" wide	
100% silicone	
Polyester knit backing	
3SU01	Bright White
3SU02	Oyster
3SU03	Zinc
3SU04	Sparrow
3SU05	Taupe
3SU06	Java
3SU07	Black
3SU08	Cherry
3SU09	Beachglass
3SU10	Midnight

Price Category 6

Balance

100% polyester	
3512	Carbon
3513	Black

Price Category 7

Customer's Own Leather

See Order Information in Appendices. Assigned lead-time textile. [A](#)

Price Category 8

No fabrics available at this time.

Proprietary Textile Colors — Seating

continued

GSA

Price Category 9

Leather	
approx. 50 sq. ft. per hide	
100% leather	
2101	Ivory
2109	Black *
2110	Smoke
2111	Graphite
2112	Khaki
2113	Rattan
2114	Truffle
2115	Alpine
2116	Haze
2117	Sable Grey
2118	Dark Mineral **
2119	Dark Carbon ***
2120	Cranberry
2121	Deep Sea

* Armpad color available on

Aeron® Chair, Graphite.

** Armpad color available on
Aeron Chair, Mineral.

*** Armpad color available on
Aeron Chair, Carbon.

For more information about our products and services or to see a list of dealers, please visit us at HermanMiller.com or call (800) 851 1196.

© 2022 Herman Miller, Inc., Zeeland, Michigan

Distribution Rights

Working together since 1956, Herman Miller and Vitra are the authentic sources of designs by Charles and Ray Eames, Alexander Girard, and George Nelson. All the designs shown in this book are protected by law. Herman Miller has obtained all rights to make and sell these designs. Also, Herman Miller holds exclusive worldwide manufacturing and distribution rights for these products with the following exceptions:

Charles and Ray Eames, George Nelson, and Alexander Girard—Worldwide distribution rights for furniture in all areas except Europe and the Middle East. For those areas, please contact Vitra.

Isamu Noguchi—Worldwide distribution rights for the Noguchi Rudder Table. Distribution rights for the Noguchi Table in North America and Central America only. For all other areas, please contact Vitra.

Magis—Exclusive distribution rights in the US and Canada. For all other areas, please contact Magis.

© HermanMiller, ●, Action Office, Aeron, Aside, Canvas Office Landscape, Caper, Cosm, Co/Struc, Eames, Embody, Ethospace, Exclave, Fine-Tune, FlexFront, Formcoat, Ground Cloth, Herman Miller Healthcare, Layout Studio, Lino, Maharam, Meridian, Mirra, Motia, Nelson, Pellicle, Perspectives, Plex, PostureFit, PostureFit SL, Resolve, Sayl, Setu, Tu, Verus, Y-Tower, and Z-Axis are among the registered trademarks of Herman Miller, Inc., and its owned subsidiaries.

™ AireWeave, Bubbletack, Cellular Suspension, Commend, Compass, Connect, DOT, Durawrap, Everywhere, Flex-Edge, Headway, Hopsak 2, Intent, Iota, Keyless Entry, Latitude, Lyris 2, Mora, Multiscrim, Nevi, Overlay, Pedastools, Renew, Stackable, Swoop, Thrive, TriFlex, Twist, Valor, and Vista are among the trademarks of Herman Miller, Inc., and its owned subsidiaries.

Chemsurf® is a registered trademark of Wilsonart International.

Corian® is a registered trademark of E.I. du Pont de Nemours and Company Corporation.

FLEXNET™ is a trademark of Milliken & Company.

Floor Saver Glide® is a registered trademark of Carpin Manufacturing, Inc.

Forest Stewardship Council® is a registered trademark of the Forest Stewardship Council A.C. (FSC). We are FSC® certified (FSC® C102895).

FSC® is a registered trademark of the Forest Stewardship Council A.C. (FSC).

Geiger® is a registered trademark of Geiger International.

MicrobeCare™ is a trademark of Parasol Medical LLC.

Microsoft® and Natural® Keyboard are registered trademarks of Microsoft Corporation.

Place Textiles® is a registered trademark of Place Textiles.