



aerospace
climate control
electromechanical
filtration
fluid & gas handling
hydraulics
pneumatics
process control
sealing & shielding







Modular Pneumatic Linear Drive Systems

ORIGA SYSTEM PLUS

PDE2690TCUK May 2016



ENGINEERING YOUR SUCCESS.

Contents	Page	Contents	Page
Origa System Plus - the concept		Brakes	
Introduction - OSP Concept	4-5	Overview	79
Modular Components Overview	6-7	ACTIVE-Brakes	
Control Examples for OSP-P	8	ACTIVE-Brake – for Standard Cylinder	80
OSP-P Application Examples	9	Plain Bearing Guide SLIDELINE – with ACTIVE-Brake	47
Rodless Pneumatic Cylinders		Aluminium-Roller Guide PROLINE with ACTIVE-Brake	50
Overview	12	PASSIVE-Brakes	
Series OSP-P Ø10 to 80 mm	16	Multi-Brake: PASSIVE-Brake with Plain Bearing Guide SLIDELINE	84
Integrated Valves VOE	23	Multi-Brake: PASSIVE-Brake with Aluminium-Roller Guide PROLINE	87
Long-Stroke Cylinders	26	OSP - Accessories	
Clean Room Cylinders	31	Overview	90
ATEX-Version 	35	Clevis Mounting	91
ATEX-Version  - BASIC GUIDE	35	End Cap Mounting	93
ATEX-Version  - Plain Bearing Guide SLIDELINE	35	Mid-Section Support	94
Bi-parting Version	37	Mountings for Linear Drives fitted with OSP-Guides	95
BASIC GUIDE BG	39	Inversion Mounting	104
Linear Guides		Adaptor Profile	105
Overview	46	T-Slot Profile	106
Plain Bearing Guide SLIDELINE	46	Connection Profile	107
Plain Bearing Guide SLIDELINE – with ACTIVE-Brake	46	Duplex Connection	108
Roller Guide POWERSLIDE	50	Multiplex Connection	109
Aluminium-Roller Guide PROLINE.....	55	Magnetic Switches	
Aluminium-Roller Guide – PROLINE with ACTIVE-Brake	55	– T-Slot Version	110
Recirculating Ball Bearing Guide STARLINE	58	– ATEX-Version 	114
– Variable stop VS	61	Cable Cover	117
Heavy Duty Guide HD	72	Displacement Measuring Systems	
– Variable stop VS	72	ORIGA SENSOFLEX	
– Intermediate stop module ZSM	76	Overview	118
		– Series SFI-plus	120



Important

Before attempting any external or internal work on the cylinder or any connected components, make sure the cylinder is vented and disconnect the air supply in order to ensure isolation of the air supply.



Note

All technical data in this catalogue are typical data only. Air quality is essential for maximum cylinder service life (see ISO 8573).



WARNING

FAILURE OR IMPROPER SELECTION OR IMPROPER USE OF THE PRODUCTS AND/OR SYSTEMS DESCRIBED HEREIN OR RELATED ITEMS CAN CAUSE DEATH, PERSONAL INJURY AND PROPERTY DAMAGE.

This document and other information from Parker Hannifin Corporation, its subsidiaries and authorized distributors provide product and/or system options for further investigation by users having technical expertise. It is important that you analyze all aspects of your application and review the information concerning the product or system in the current product catalog. Due to the variety of operating conditions and applications for these products or systems, the user, through its own analysis and testing, is solely responsible for making the final selection of the products and systems and assuring that all performance, safety and warning requirements of the application are met. The products described herein, including without limitation, product features, specifications, designs, availability and pricing, are subject to change by Parker Hannifin Corporation and its subsidiaries at any time without notice.

SALE CONDITIONS

The items described in this document are available for sale by Parker Hannifin Corporation, its subsidiaries or its authorized distributors. Any sale contract entered into by Parker will be governed by the provisions stated in Parker's standard terms and conditions of sale (copy available upon request).

Parker Origa rodless pneumatic cylinders are the first rodless cylinders that have been approved for use in potentially explosive atmospheres in Equipment Group II, Category 2 GD.

The Cylinders are to the ATEX Certification 94/9/EG (ATEX 95) for Pneumatic Components.

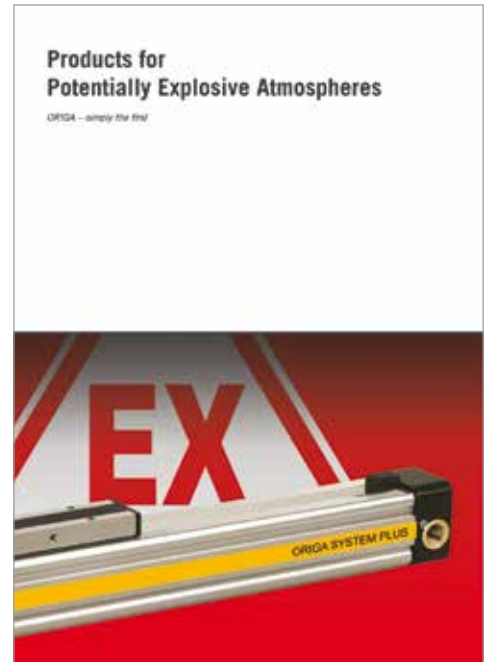

Special Versions



for use in Ex-Areas



Low Temperature Version for temperatures down to -40°C



for Clean Room Applications certified to DIN EN ISO 14644-1



Slow Speed Version $v = 0.005 - 0.2 \text{ m/s}$



Stainless steel version for special applications



High Speed Version $v_{\text{max.}} = 30 \text{ m/s}$



with special pneumatic cushioning system for cycle time optimization, for $\varnothing 16$ to 50 mm – on request



Cylinders with extreme long strokes Stroke length up to 41 m



High Temperature Version for temperatures up to +120°C

One Concept - Three Drive Options

Based on the Parker Origa rodless cylinder, proven in world wide markets, Parker Origa now offers the complete solution for linear drive systems. Designed for absolute reliability, high performance, ease of use and optimised engineering the ORIGA SYSTEM PLUS satisfies even the most demanding applications.

ORIGA SYSTEM PLUS

is a totally modular concept which offers the choice of pneumatic or electric actuation, with guidance and control modules to suit the exact needs of individual installations.

The actuators at the core of the system all have a common aluminium extruded profile, with double dovetail mounting rails on three sides, these are the

principle building blocks of the system to which all modular options are directly attached.



SYSTEM MODULARITY

• Pneumatic Drive

- For all round versatility and convenience, combining ease of control and broad performance capability. Ideally suited for point-to-point operations, reciprocating movements and simple traverse / transfer applications.

• Electric Screw Drive

- For high force capability and accurate path and position control.

For additional informations on electrical linear drives OSP-E, please refer to catalogue P-A4 P017E.

• Electric Belt Drive

- For high speed applications, accurate path and position control and longer strokes.

For additional informations on electrical linear drives OSP-E, please refer to catalogue P-A4 P017E.

- Different guidance options provide the necessary level of precision, performance and duty for various applications.
- Compact solutions, which are simple to install and can be easily retro-fitted.
- Valves and control options can be directly mounted to the actuator system.
- Diverse mounting options to provide total installation flexibility.



* Information on electrical linear drives series OSP-E, please refer to catalogue P-A4P017GB

<p>Basic Linear Drive Standard Version</p> <ul style="list-style-type: none"> Series OSP-P Series OSP-E* Belt drive Belt drive with integrated Guides Vertical belt drive with recirculating ball bearing guide Series OSP-E* Screw drive (Ball Screw, Trapezoidal Screw) 		<p>BASIC GUIDE</p> <ul style="list-style-type: none"> Series OSPP-BG 	
<p>Air Connection on the End-face or both at One End</p> <ul style="list-style-type: none"> Series OSP-P 		<p>Duplex Connection</p> <ul style="list-style-type: none"> Series OSP-P 	
<p>Long-Stroke Cylinders for strokes up to 41 m</p> <ul style="list-style-type: none"> Series OSP-P 		<p>Multiplex Connection</p> <ul style="list-style-type: none"> Series OSP-P 	
<p>Clean Room Cylinder certified to DIN EN ISO 14644-1</p> <ul style="list-style-type: none"> Series OSP-P Series OSP-E..SB 		<p>Linear Guides – SLIDELINE</p> <ul style="list-style-type: none"> Series OSP-P Series OSP-E Screw drive* 	
<p>Products for ATEX Areas</p> <ul style="list-style-type: none"> Series OSP-P Rodless Cylinders 		<p>Linear Guides – POWERSLIDE</p> <ul style="list-style-type: none"> Series OSP-P Series OSP-E Belt drive* Series OSP-E Screw drive* 	
<p>Products for ATEX Areas</p> <ul style="list-style-type: none"> Series OSP-P Rodless Cylinders with Linear Guide BASIC GUIDE 		<p>Linear Guides – PROLINE</p> <ul style="list-style-type: none"> Series OSP-P Series OSP-E Belt drive* Series OSP-E Screw drive* 	
<p>Products for ATEX Areas</p> <ul style="list-style-type: none"> Series OSP-P Rodless Cylinders with Linear Guide SLIDELINE 		<p>Linear Guides – STARLINE</p> <ul style="list-style-type: none"> Series OSP-P 	
<p>Bi-parting Version</p> <ul style="list-style-type: none"> Series OSP-P 		<p>Linear Guides – KF</p> <ul style="list-style-type: none"> Series OSP-P 	
<p>Integrated 3/2 Way Valves</p> <ul style="list-style-type: none"> Series OSP-P 		<p>Heavy Duty Linear Guides – HD</p> <ul style="list-style-type: none"> Series OSP-P Series OSP-E Screw drive* 	
<p>Clevis Mounting</p> <ul style="list-style-type: none"> Series OSP-P Series OSP-E Belt drive* Series OSP-E Screw drive* 		<p>Intermediate stop module – ZSM</p> <ul style="list-style-type: none"> Series OSP-P 	
<p>End Cap Mounting</p> <ul style="list-style-type: none"> Series OSP-P Series OSP-E Belt drive* Series OSP-E Screw drive* 		<p>Brakes</p> <ul style="list-style-type: none"> Active Brakes Passive Brakes 	
<p>Mid-Section Support</p> <ul style="list-style-type: none"> Series OSP-P Series OSP-E Belt drive* Series OSP-E Screw drive* 		<p>Magnetic Switches</p> <ul style="list-style-type: none"> Series OSP-P Series OSP-E Belt drive* Series OSP-E Screw drive* ATEX-Versions 	
<p>Inversion Mounting</p> <ul style="list-style-type: none"> Series OSP-P Series OSP-E Belt drive* Series OSP-E Screw drive* 		<p>SENSOFLEX-Measuring system</p> <ul style="list-style-type: none"> Series SFI-plus 	
<p>Inversion Mounting</p> <ul style="list-style-type: none"> Series OSP-P Series OSP-E Belt drive* Series OSP-E Screw drive* 		<p>Variable Stop VS</p> <ul style="list-style-type: none"> Series OSP-P with Linear Guide STL, KF, HD 	

OSP-P Modular Pneumatic Linear Drive Systems

Linear Drives	OSP-P10	OSP-P16	OSP-P25	OSP-P32	OSP-P40	OSP-P50	OSP-P63	OSP-P80
Theoretical force at 6 bar [N]	47	120	295	483	754	1178	1870	3010
Effective force at 6 bar [N]	32	78	250	420	640	1000	1550	2600
Velocity v [m/s]	>0.005	>0.005	>0.005	>0.005	>0.005	>0.005	>0.005	>0.005
Magnetic piston (three sides)	X	☐	☐	☐	☐	☐	☐	☐
Lubrication - prelubricated	☐	☐	☐	☐	☐	☐	☐	☐
Multiple air ports (4 x 90°)	X	☐	☐	☐	☐	☐	☐	☐
Both Air Connections at End-face	X	○	○	○	○	○	○	○
Air Connection on the End-face	X	○	○	○	○	○	○	○
Cushioning	☐	☐	☐	☐	☐	☐	☐	☐
Cushioning length [mm]	2,50	11	17	20	27	30	32	39
Stroke length [mm]	1 - 6000	1 - 6000	1 - 6000	1 - 6000	1 - 6000	1 - 6000	1 - 6000	1 - 6000
Pressure range p_{max} [bar]	8.0	8.0	8.0	8.0	8.0	8.0	8.0	8.0
Temperature range [°C]	-10-+80	-10-+80	-10-+80	-10-+80	-10-+80	-10-+80	-10-+80	-10-+80
Viton / chemical resistance	○	○	○	○	○	○	○	○
Stainless steel parts	○	○	○	○	○	○	○	○
Clevis Mounting	○	○	○	○	○	○	○	○
Slow speed lubrication	○	○	○	○	○	○	○	○
Duplex Connection / Multiplex Connection	X	on request	○	○	○	○	on request	on request
Tandem piston	○	○	○	○	○	○	○	○
Basic Cylinder								
F [N]	20	120	300	450	750	1200	1650	2400
M_x [Nm]	0.2	0.45	1.5	3	6	10	12	24
M_y [Nm]	1	4	15	30	60	115	200	360
M_z [Nm]	0.3	0.5	3	5	8	15	24	48
Basic Guide								
F [N]	X	X	590	850	1600	2000	X	X
M_x [Nm]	X	X	10	17	39	67	X	X
M_y [Nm]	X	X	28	43	110	165	X	X
M_z [Nm]	X	X	28	43	110	165	X	X
Slideline								
F [N]	X	325	675	925	1600	2000	2500	2500
M_x [Nm]	X	6	14	29	50	77	120	120
M_y [Nm]	X	11	34	60	110	180	260	260
M_z [Nm]	X	11	34	60	110	180	260	260
Proline								
F [N]	X	542	857	1171	2074	3111	X	X
M_x [Nm]	X	8	16	29	57	111	X	X
M_y [Nm]	X	12	39	73	158	249	X	X
M_z [Nm]	X	12	39	73	158	249	X	X
Powerslide								
F [N]	X	1400	1400-3000	1400-3000	3000	3000-4000	X	X
M_x [Nm]	X	14	14-65	20-65	65-90	90-140	X	X
M_y [Nm]	X	45	63-175	70-175	175-250	250-350	X	X
M_z [Nm]	X	45	63-175	70-175	175-250	250-350	X	X
Starline								
F [N]	X	1000	3100	3100	4000-7500	4000-7500	X	X
M_x [Nm]	X	15	50	62	150	210	X	X
M_y [Nm]	X	30	110	160	400	580	X	X
M_z [Nm]	X	30	110	160	400	580	X	X
- variable Stop	X	○	○	○	○	○	X	X

OSP-P Modular Pneumatic Linear Drive Systems

Linear Drives	OSP-P10	OSP-P16	OSP-P25	OSP-P32	OSP-P40	OSP-P50	OSP-P63	OSP-P80
KF-Guide								
F [N]	X	1000	3100	3100	4000-7100	4000-7500	X	X
M _x [Nm]	X	12	35	44	119	170	X	X
M _y [Nm]	X	25	90	133	346	480	X	X
M _z [Nm]	X	25	90	133	346	480	X	X
- variable Stop	X	○	○	○	○	○	X	X
HD Heavy Duty Guide								
F [N]	X	X	6000	6000	15000	18000	X	X
M _x [Nm]	X	X	260	285	800	1100	X	X
M _y [Nm]	X	X	320	475	1100	1400	X	X
M _z [Nm]	X	X	320	475	1100	1400	X	X
- Variable Stop	X	X	○	○	○	○	X	X
- Intermediate stop module	X	X	○	X	X	X	X	X
ACTIVE Brake								
Braking force at 6 bar (brake surface dry) [N]	X	X	350	590	900	1400	2170	4000
Slideline SL / Proline PL with Brakes								
ACTIVE Brake								
SL Braking force at 6 bar (brake surface dry) [N]	X	X	325	545	835	1200	X	X
PL Braking force at 6 bar (brake surface dry) [N]	X	X	on request	on request	on request	on request	X	X
Passive Brake Multibrake								
SL Braking force (brake surface dry) [N]	X	X	470	790	1200	1870	2900	2900
PL Braking force (brake surface dry) [N]	X	X	315	490	715	1100	-	-
Magnetic Switches								
T-Slot-Version	○	○	○	○	○	○	○	○
ATEX-Version for EX- Areas 	○	○	○	○	○	○	○	○
Displacement measuring systems								
SFI-plus incremental	X	X	○	○	○	○	○	○
Integrated valves 3/2 WV NO VOE	X	X	○	○	○	○	on request	on request
Mountings								
End Cap Mounting / Mid-Section Support	○	○	○	○	○	○	○	○
Inversion Mounting	X	○	○	○	○	○	○	○
Shock absorber for intermediate positioning	X	X	on request	on request	on request	on request	X	X
Adaptor Profile / T-Slot Profile	X	○	○	○	○	○	○/X	X
Special Cylinders								
Special Pneumactical Cushioning System	X	on request	on request	on request	on request	on request	X	X
Clean Room Cylinders to DIN EN ISO 14644-1	X	○	○	○	X	X	X	X
Long-Stroke Cylinders (max. stroke length 41 m)	X	X	X	X	X	○	○	○
ATEX-Version for EX-Areas 	○	○	○	○	○	○	○	○
Bi-parting Version	X	X	X	X	○	X	X	X
High-Speed up to 30 m/s	X	on request	on request	on request	X	X	X	X

- = Standard version
 ▲ = longer strokes on request
 * = other temperature ranges on request
 ○ = Option
 X = not applicable

Control examples for OSP-P

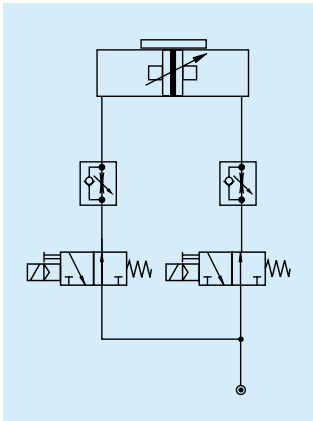

Circuit diagram for end of stroke application. Intermediate positioning is also possible.

The cylinder is controlled by two 3/2-way valves (normally open). The speed can be adjusted independantly for both directions.

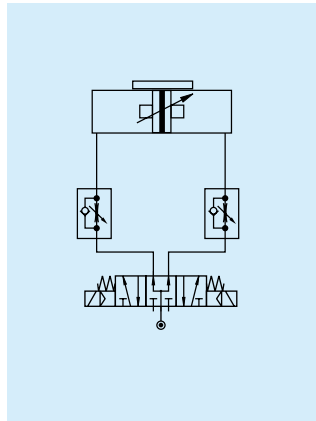

Circuit diagram for end of stroke application. Intermediate positioning is also possible.

The cylinder is controlled by a 5/3-way valve (middle position pressurized). The speed can be adjusted independantly for both directions.

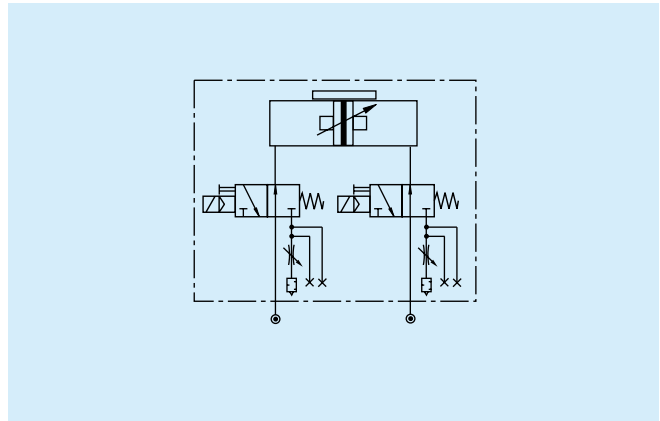

The optional integrated VVOE Valves offer optimal control, and allow accurate

positioning of intermediate positions and the lowest possible speeds.

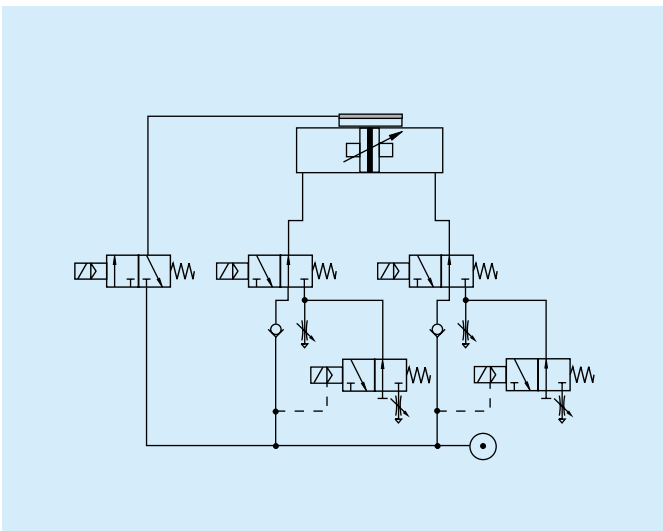

Fast/Slow speed cycle control with pneumatic brake for accurate positioning at high velocities. Additional 3/2-way valves with adjustable throttle valves at the exhaust of the standard directional control valves for two displacement speeds

in each direction of the piston's travel. The valve controlling the brake is activated after the slow speed cycle is activated

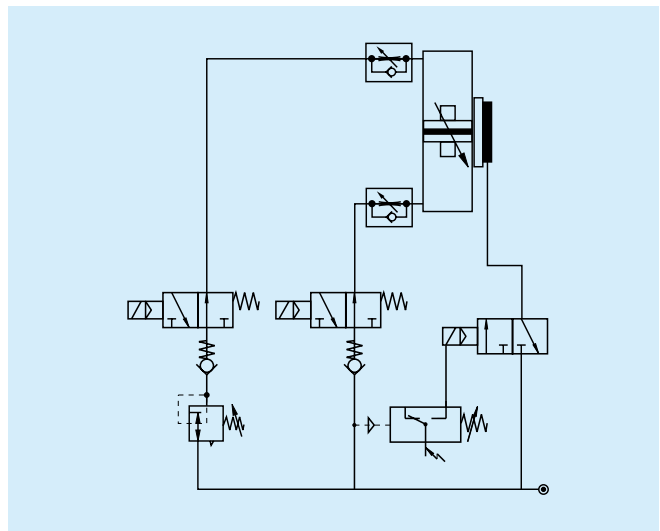

The combination of an OSP-cylinder with the passive MULTIBRAKE as shown here, allows accurate positioning and safety in case of loss of pneumatic air pressure.

OSP-P Application examples

ORIGA SYSTEM PLUS – rodless linear drives offer maximum flexibility for any application.

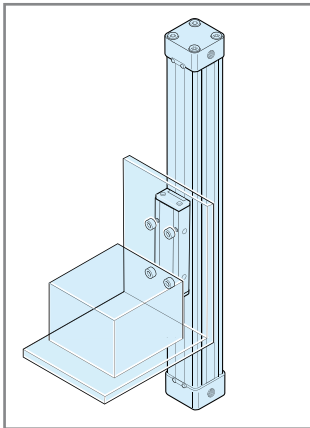

The high load capacity of the piston can cope with high bending moments without additional guides.

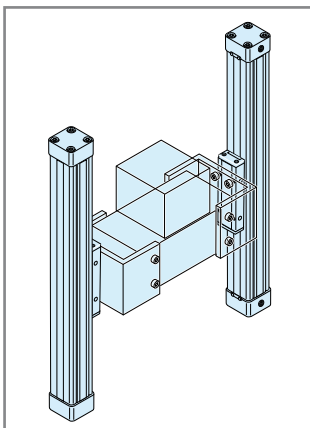
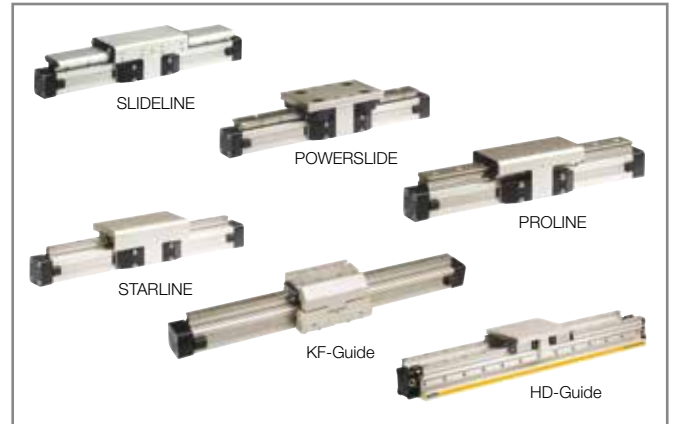

The mechanical design of the OSP-P allows synchronised movement of two cylinders.

Integrated guides offer optimal guidance for applications requiring high performance, easy assembly and maintenance free operation.

Optimal system performance by combining multi-axis cylinder combinations.

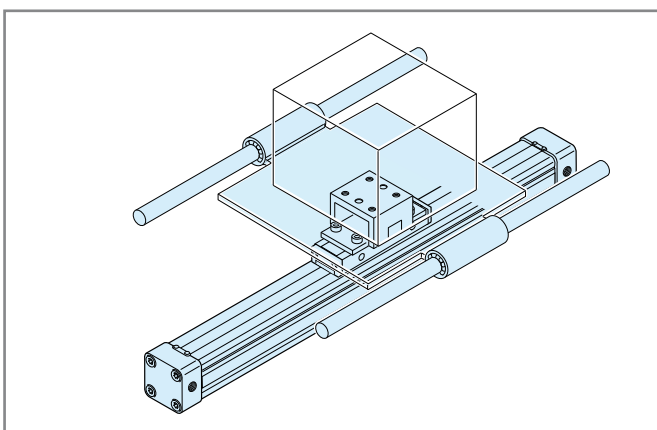

When using external guides, the clevis mounting is used to compensate for deviations in parallelism.

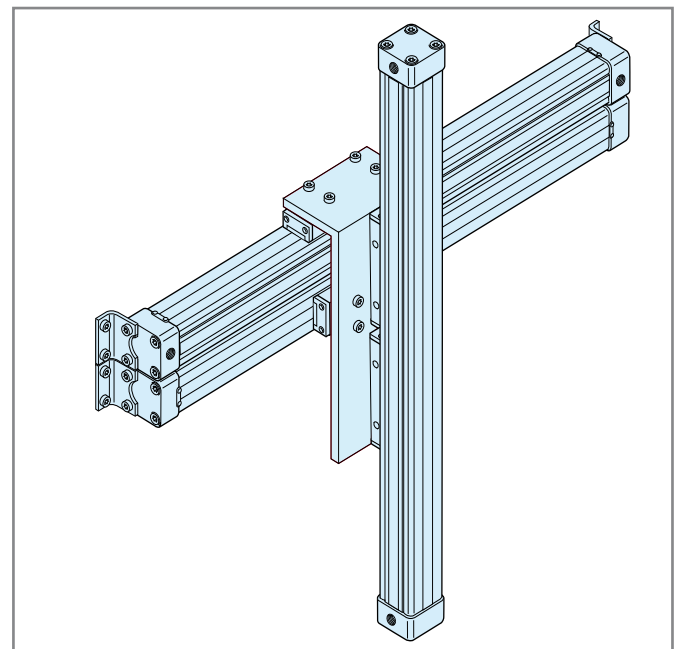

For further information and assembly instructions, please contact your local Parker Origa dealer.

Rodless Pneumatic Cylinders

OSP-P Series



Contents	Page
Standard Cylinders	
Overview	12-13
Technical data	16
Dimensions	19
Order Instructions	25
Long-Stroke Cylinders	
Technical data	26
Dimensions	28
Order Instructions	30
Clean Room Cylinders	
Technical data	31
Dimensions	33
Order Instructions	34
Cylinders ATEX-Version 	
Technical data	35
Dimensions	19
Order Instructions	36
Cylinders for synchronized bi-parting movements	
Technical data	37
Dimensions	38
Order Instructions	38
BASIC GUIDE	
Technical data	40
Dimensions	42
Order Instructions	45

Origa System Plus

- Innovation from a proven design

A completely new generation of linear drives which can be simply and neatly integrated into any machine layout.

A NEW MODULAR LINEAR DRIVE SYSTEM

With this second generation linear drive Parker Origa offers design engineers complete flexibility. The well known ORIGA cylinder has been further developed into a combined linear actuator, guidance and control package. It forms the basis for the new, versatile ORIGA SYSTEM PLUS linear drive system.

All additional functions are designed into modular system components which replace the previous series of cylinders.

MOUNTING RAILS ON 3 SIDES

Mounting rails on 3 sides of the cylinder enable modular components such as linear guides, brakes, valves, magnetic switches etc. to be fitted to the cylinder itself. This solves many installation problems, especially where space is limited.

The modular system concept forms an ideal basis for additional customer specific functions.

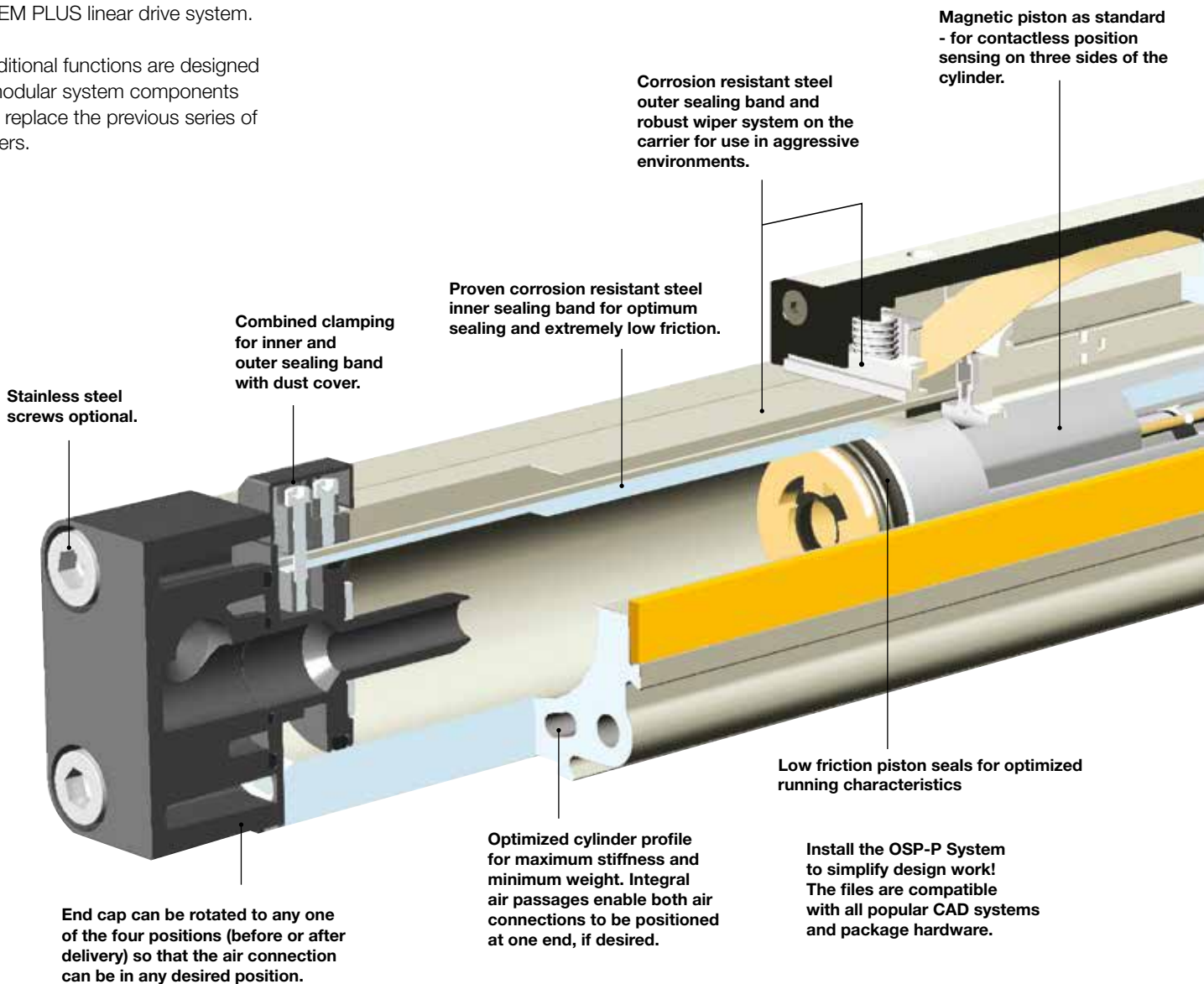

OSP-P Modular Pneumatic Linear Drive Systems

Clean Room Version
certified to DIN EN ISO 14644-1



Rodless Cylinder
for synchronized bi-parting movements



New low profile piston/carrier design.

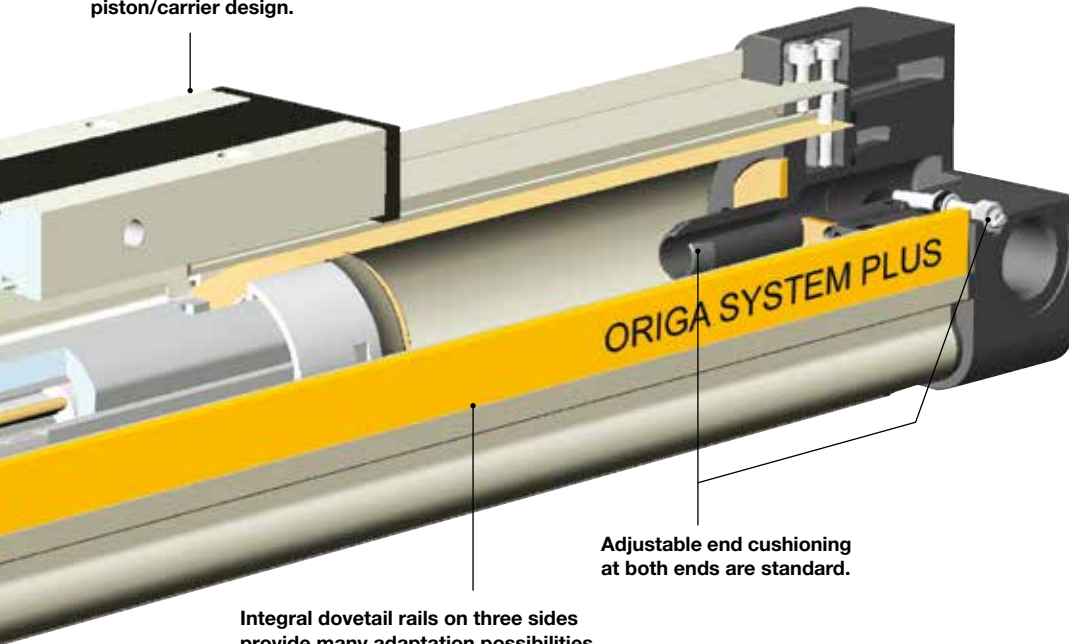

Adjustable end cushioning at both ends are standard.

Integral dovetail rails on three sides provide many adaptation possibilities (linear guides, magnetic switches, etc.).

Modular system components are simply clamped on.

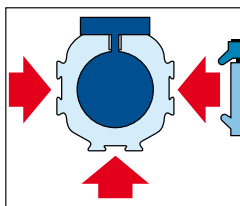

INTEGRATED VOE VALVES
The complete compact solution for optimal cylinder control.



SENSOFLEX SFI-plus
incremental measuring system with 0.1 (1.0) mm resolution.



BASIC GUIDE
Compact, robust plain bearing guide for medium loads.



SLIDELINE
Guide system for moderate loads. Optional with Active- / Passive-Brake.



POWERSLIDE
Roller guide for high loads and rough conditions.



PROLINE
The compact aluminium roller guide for high loads and velocities. Optional with Active- / Passive-Brake.



STARLINE
Recirculating ball bearing guide for very high loads and precision.



KF GUIDE
Recirculating ball bearing guide – the mounting dimensions correspond to FESTO Type: DGPL-KF



HEAVY DUTY GUIDE HD
for heavy duty applications.



VARIABLE STOP VS
The variable stop provides simple stroke limitation.



PASSIVE BRAKE
reacts automatically to pressure failure.



ACTIVE BRAKE
pneumatic brake for secure, positive stopping at any position.



Options and Accessories for system versatility

Series OSP-P

STANDARD VERSIONS OSP-P10 to P80

Standard carrier with integral guidance. End cap can be rotated 4 x 90° to position air connection on any side.

Magnetic piston as standard. Dovetail profile for mounting of accessories and the cylinder itself.



LONG-STROKE VERSION

For extremely long strokes up to max. 41m



BASIC CYLINDER OPTIONS

CLEAN ROOM CYLINDERS

For use in clean room applications, certified with the IPA-Certificate (to DIN EN ISO 14644-1).

The special design of the linear drive enables all emissions to be led away.



ATEX-Version

For use in Ex-Areas



BOTH AIR CONNECTIONS AT ONE END

For simplified tubing connections and space saving.



STAINLESS VERSION

For use in constantly damp or wet environments. All screws are A2 quality stainless steel (material no.1.4301 / 1.4303)



INTEGRATED VOE VALVES

The complete compact solution for optimal cylinder control.



SLOW SPEED OPTIONS

Specially formulated grease lubrication facilitates slow, smooth and uniform piston travel in the speed range from 0.005 to 0.2 m/s.

Minimum achievable speeds are dependent on several factors. Please consult our technical department.

Slow speed lubrication in combination with Viton® on demand. Oil free operation preferred.



DUPLEX CONNECTION

The duplex connection combines two OSP-P cylinders of the same size into a compact unit with high performance.



VITON® VERSION

For use in an environment with high temperatures or in chemically aggressive areas.

All seals are made of Viton®. Corrosion resistant steel sealing bands.



END-FACE AIR CONNECTION

To solve special installation problems.



MULTIPLEX CONNECTION

The multiplex connection combines two or more OSP-P cylinders of the same size into one unit.

The orientation of the carriers can be freely selected.



ACCESSORIES

**MAGNETIC SWITCHES
TYPE RS, ES, RST, EST**

For electrical sensing of end and intermediate piston positions, also in EX-Areas.



**MOUNTING FOR
OSP-P10 UP TO P80**

CLEVIS MOUNTING

Carrier with tolerance and parallelism compensation for driving loads supported by external linear guides.



MID-SECTION SUPPORT

For supporting long cylinders or mounting the cylinder by its dovetail rails.



END CAP MOUNTING

For end-mounting of the cylinder.



INVERSION MOUNTING

The inversion mounting transfers the driving force to the opposite side, e.g. for dirty environments.



OSP-P Modular Pneumatic Linear Drive Systems

Rodless Pneumatic Cylinder Ø 10-80 mm

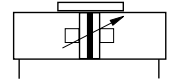

Standard Versions:

- Double-acting with adjustable end cushioning
- With magnetic piston for position sensing

Long-Stroke Cylinders for stroke lengths up to 41 m
See page 26



Special Versions:

- Cushioning system for cycle time optimization (on request)
- Clean room cylinders
- ATEX-Version 
- Stainless steel screws
- Slow speed lubrication
- Viton® seals
- Both air connections on one end
- Air connection on the end-face
- Integrated Valves
- End cap can be rotated 4 x 90° to position air connection as desired
- Free choice of stroke length up to 6000 mm, Long-Stroke version (Ø50-80mm) for stroke lengths up to 41 m

Size Comparison

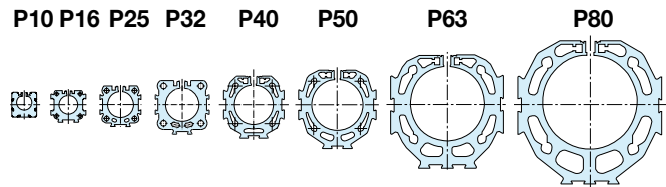

Characteristics	Description
General Features	
Type	Rodless cylinder
Series	OSP-P
System	Double-acting, with cushioning, position sensing capability
Mounting	See drawings
Air Connection	Threaded
Ambient temperature range	T_{min} -10 °C Other temperature ranges T_{max} +80 °C on request
Installation	In any position
Medium	Filtered, unlubricated compressed air (other media on request)
Lubrication	Permanent grease lubrication (additional oil mist lubrication not required) Option: special slow speed grease
Material	
Cylinder Profile	Anodized aluminium
Carrier (piston)	Anodized aluminium
End caps	Aluminium, lacquered / Plastic (P10)
Sealing bands	Corrosion resistant steel
Seals	NBR (Option: Viton®)
Screws	Galvanized steel Option: stainless steel
Dust covers, wipers	Plastic
Max. operating pressure p_{max}	8 bar

OSP-P Modular Pneumatic Linear Drive Systems

Loads, Forces and Moments

Choice of cylinder is decided by:

- Permissible loads, forces and moments
- Performance of the pneumatic end cushions.

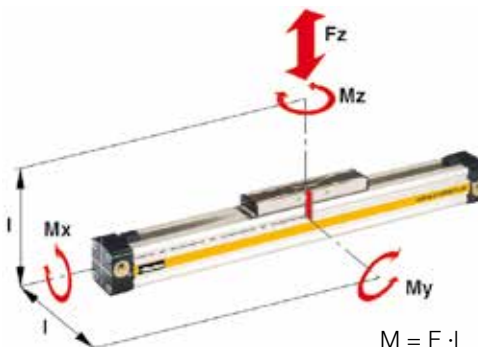

$M = F \cdot l$
Bending moments are calculated from the centre of the linear actuator

The main factors here are the mass to be cushioned and the piston speed at start of cushioning (unless external cushioning is used, e. g. hydraulic shock absorbers).

The adjacent table shows the maximum values for light, shock-free operation, which must not be exceeded even in dynamic operation. Load and moment data are based on speeds $v \leq 0.5$ m/s.

When working out the action force required, it is essential to take into account the friction forces generated by the specific application or load.

Cylinder-Series Ø [mm]	Theoretical Action Force at 6 bar [N]	effective Action Force F_A at 6 bar [N]	max. Moments			max. Load F [N]	Cushion Length [mm]
			M_x [Nm]	M_y [Nm]	M_z [Nm]		
OSP-P10	47	32	0.2	10.3	20	2.5 *	
OSP-P16	120	78	0.45	40.5	120	11	
OSP-P25	295	250	1.5	15	3	300	17
OSP-P32	483	420	3	30	5	450	20
OSP-P40	754	640	6	60	8	750	27
OSP-P50	1178	1000	10	115	15	1200	30
OSP-P63	1870	1550	12	200	24	1650	32
OSP-P80	3016	2600	24	360	48	2400	39

* A rubber element (non-adjustable) is used for end cushioning. To deform the rubber element enough to reach the absolute end position would require a Δp of 4 bar!

Cushioning Diagram

Work out your expected moving mass and read off the maximum permissible speed at start of cushioning. Alternatively, take your desired speed and expected mass and find the cylinder size required. Please note that piston speed at start of cushioning is typically ca. 50 % higher than the average speed, and that it is this higher speed which determines the choice of cylinder.

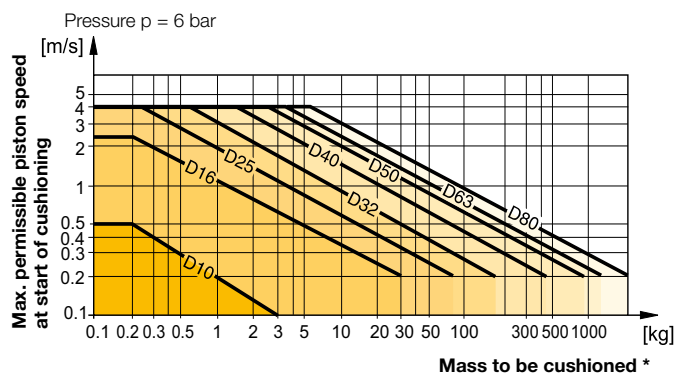

Weight (mass) [kg]

Cylinder series (Basic cylinder)	Weight (Mass) [kg]	
	At 0 mm stroke	per 100 mm stroke
OSP-P10	0.087	0.052
OSP-P16	0.22	0.1
OSP-P25	0.65	0.197
OSP-P32	1.44	0.354
OSP-P40	1.95	0.415
OSP-P50	3.53	0.566
OSP-P63	6.41	0.925
OSP-P80	12.46	1.262

* For cylinders with linear guides or brakes, please be sure to take the mass of the carriage or the brake housing into account.

If the permitted limit values are exceeded, either additional shock absorbers should be fitted in the area of the centre of gravity or you can consult us about our special cushioning system – we shall be happy to advise you on your specific application.

Mid-Section Supports

To avoid excessive bending and oscillation of the cylinder, mid-section supports are required dependent on specified stroke lengths and applied loads.

The diagrams show the maximum possible support spacings depending on the load.

Bending up to max. 0.5 mm is permissible between supports. The mid-section supports are clamped on to the dovetail profile of the cylinder tube. They are also able to take the axial forces.

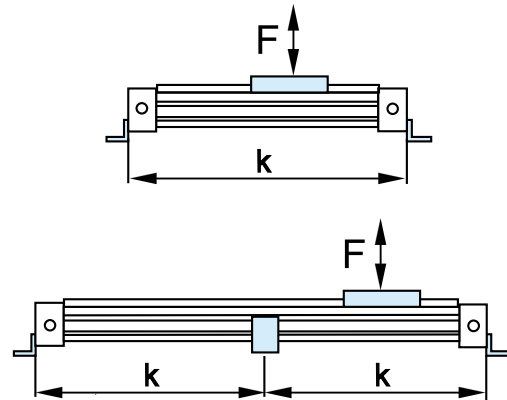

Permissible Support Spacings: OSP - P10 - P32

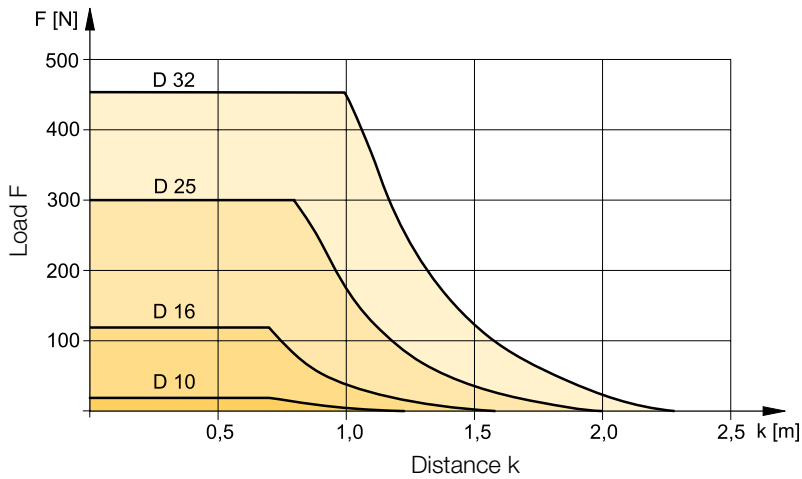

Permissible Support Spacings: OSP - P40 - P80

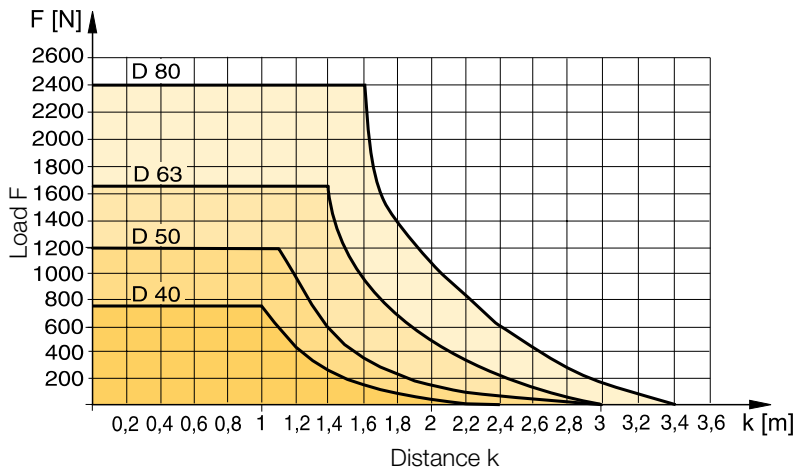

OSP-P Modular Pneumatic Linear Drive Systems

Cylinder Stroke and Dead Length A

- Free choice of stroke length up to 6000 mm in 1 mm steps.
- Longer strokes on request

Dimensions of Basic Cylinder OSP-P10

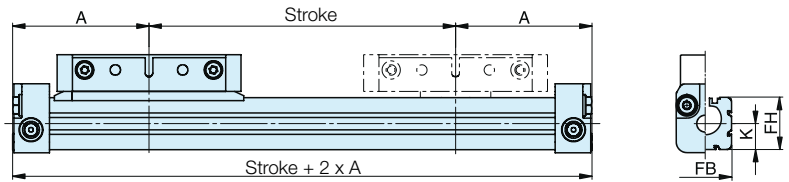

Tandem Cylinder

Two pistons are fitted: dimension "Z" is optional. (Please note minimum distance "Zmin").

- Free choice of stroke length up to 6000 mm in 1 mm steps
- Longer strokes on request
- Stroke length to order is stroke + dimension "Z"

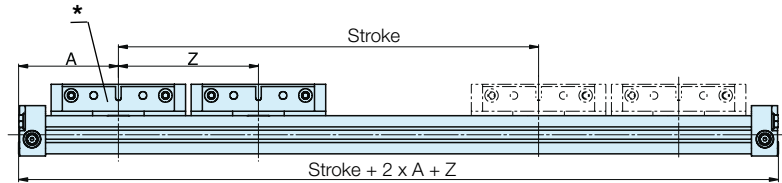

Please note:

To avoid multiple actuation of magnetic switches, the second piston is not equipped with magnets.

* Piston with magnet

End Cap / Air Connection - Series OSP-P10

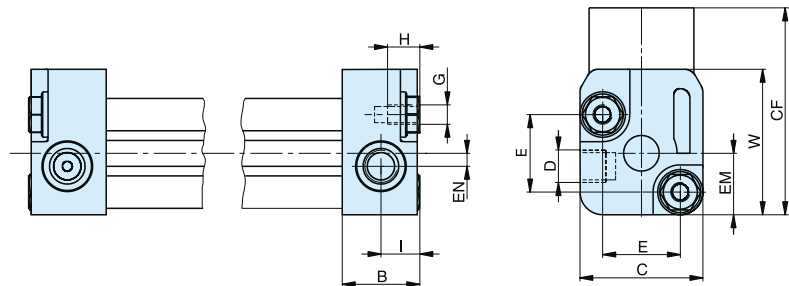

Carrier - Series OSP-P10

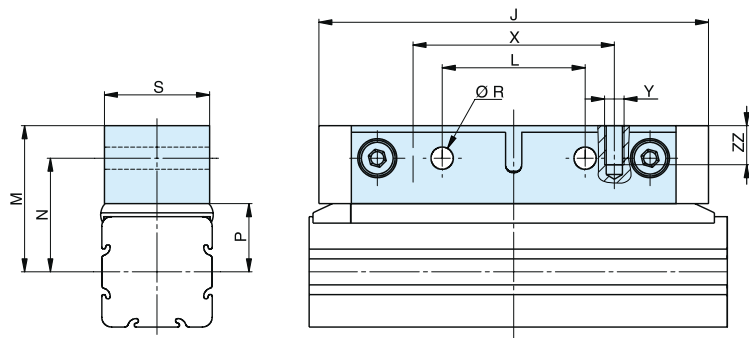

Dimensions [mm]

Series	A	B	C	D	E	G	H	I	J	K	L	M	N	P	R	S	W	X	Y	Z _{min}	CF	EM	EN	FB	FH	ZZ
OSP-P10	44.5	12	19	M5	12	M3	5	6	60	8.5	22	22.5	17.5	10.5	3.4	16	22.5	31	M3	64	32	9.5	2	17	17	6



OSP-P Modular Pneumatic Linear Drive Systems

Cylinder Stroke and Dead Length A

- Free choice of stroke length up to 6000 mm in 1 mm steps.
- Longer strokes on request

Dimensions of Basic Cylinder OSP-P16_P80

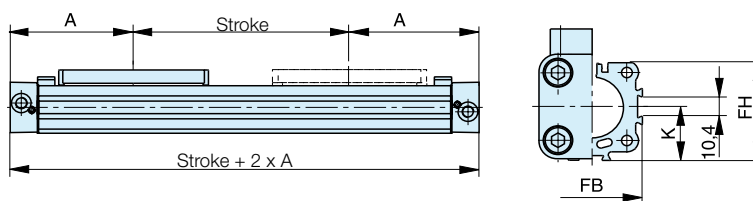

Tandem Cylinder

Two pistons are fitted: dimension "Z" is optional. (Please note minimum distance "Zmin").

- Free choice of stroke length up to 6000 mm in 1 mm steps
- Longer strokes on request
- Stroke length to order is stroke + dimension "Z"

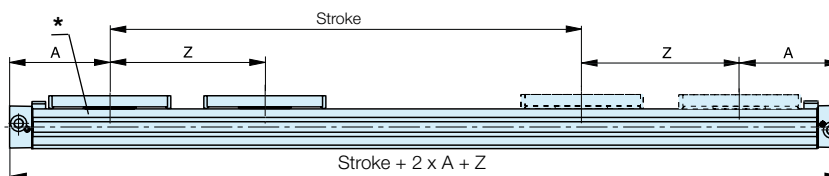

End Cap/Air Connection can be rotated 4 x 90° Series OSP-P16 to P32

Please note:

To avoid multiple actuation of magnetic switches, the second piston is not equipped with magnets.

* Piston with magnet

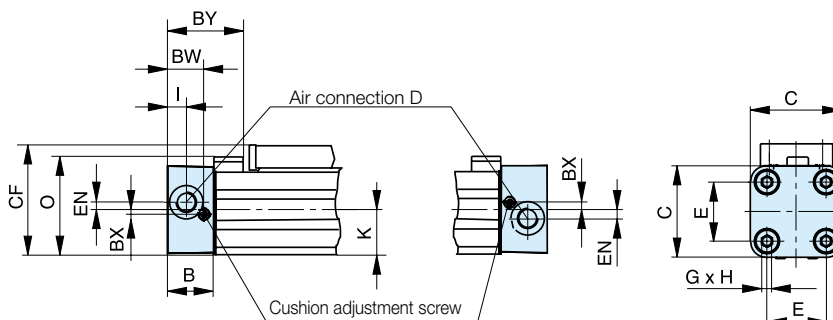

Carrier Series OSP-P16 to P80

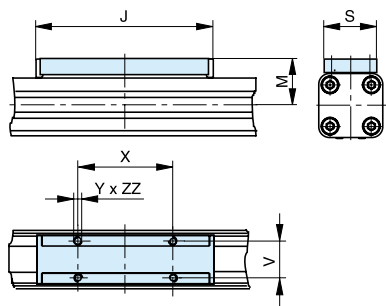

End Cap/Air Connection can be rotated 4 x 90° Series OSP-P40 to P80

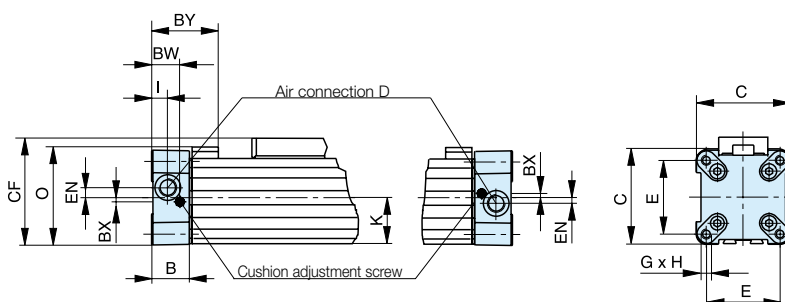

Dimensions [mm]

Series	A	B	C	D	E	G	H	I	J	K	M	O	S	V	X	Y	Z _{min}	BW	BX	BY	CF	EN	FB	FH	ZZ
OSP-P16	65	14	30	M5	18	M3	9	5.5	69	15	23	33.2	22	16.5	36	M4	81	10.8	1.8	28.4	38	3	30	27.2	7
OSP-P25	100	22	41	G1/8	27	M5	15	9	117	21.5	31	47	33	25	65	M5	128	17.5	2.2	40	52.5	3.6	40	39.5	8
OSP-P32	125	25.5	52	G1/4	36	M6	15	11.5	152	28.5	38	59	36	27	90	M6	170	20.5	2.5	44	66.5	5.5	52	51.7	10
OSP-P40	150	28	69	G1/4	54	M6	15	12	152	34	44	72	36	27	90	M6	212	21	3	54	78.5	7.5	62	63	10
OSP-P50	175	33	87	G1/4	70	M6	15	14.5	200	43	49	86	36	27	110	M6	251	27	-	59	92.5	11	76	77	10
OSP-P63	215	38	106	G3/8	78	M8	21	14.5	256	54	63	107	50	34	140	M8	313	30	-	64	117	12	96	96	16
OSP-P80	260	47	132	G1/2	96	M10	25	22	348	67	80	133	52	36	190	M10	384	37.5	-	73	147	16.5	122	122	20

OSP-P Modular Pneumatic Linear Drive Systems

Air Connection on the End-face



In some situations it is necessary or desirable to fit a special end cap with the air connection on the end-face instead of the standard end cap with the air connection on the side. The special end cap can also be rotated 4 x 90° to locate the cushion adjustment screw as desired. Supplied in pairs.

Dimensions - Series OSP-P16 to P32

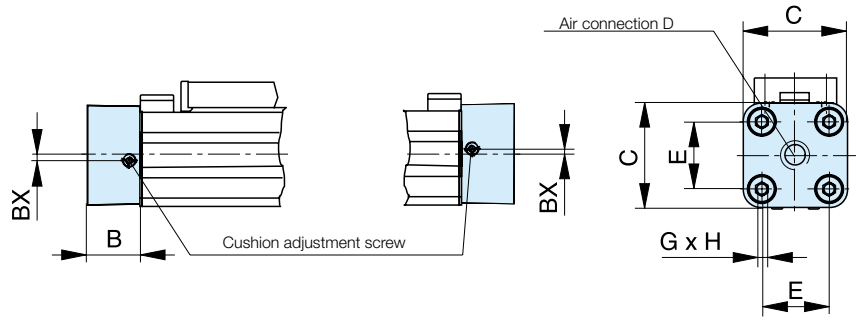

Dimensions - Series OSP-P40 to P80

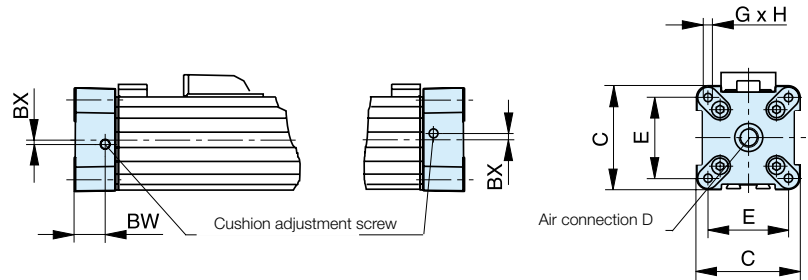

Dimensions [mm]

Series	B	C	D	E	G	H	BX	BW
OSP-P16	14	30	M5	18	M3	9	1.8	10.8
OSP-P25	22	41	G1/8	27	M5	15	2.2	17.5
OSP-P32	25.5	52	G1/4	36	M6	15	2.5	20.5
OSP-P40	28	69	G1/4	54	M6	15	3	21
OSP-P50	33	87	G1/4	70	M6	15	-	27
OSP-P63	38	106	G3/8	78	M8	21	-	30
OSP-P80	47	132	G1/2	96	M10	25	-	37.5

OSP-P Modular Pneumatic Linear Drive Systems

Both Air Connections at One End



A special end cap with both air connections on one side is available for situations where shortage of space, simplicity of installation or the nature of the process make it desirable. Air supply to the other end is via internal air passages (OSP-P25 to P80) or via a hollow aluminium profile fitted externally (OSP-P16). In this case the end caps cannot be rotated.

Please note:

When combining the OSP-P16 single end porting with inversion mountings, RS magnetic switches can only be mounted directly opposite to the external air-supply profile.

Dimensions - Series OSP-P16

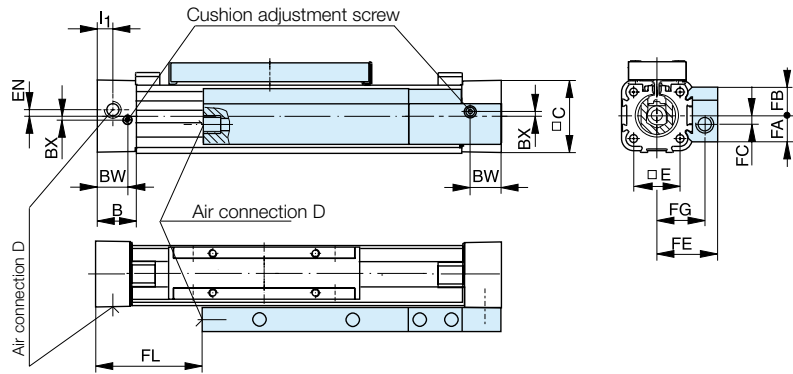

Dimensions - Series OSP-P25

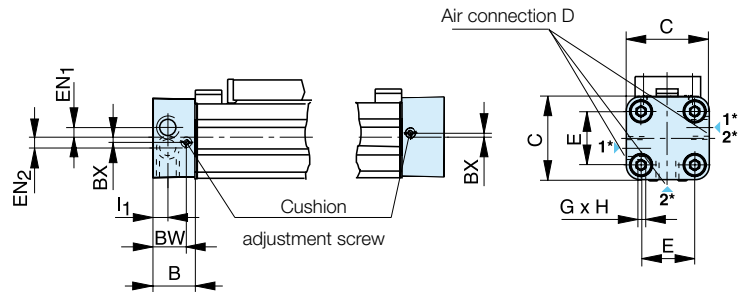

* Versions of air connection positions 1=>1 or 2=>2, the unused connection must be closed!

Dimensions - Series OSP-P32 to P80

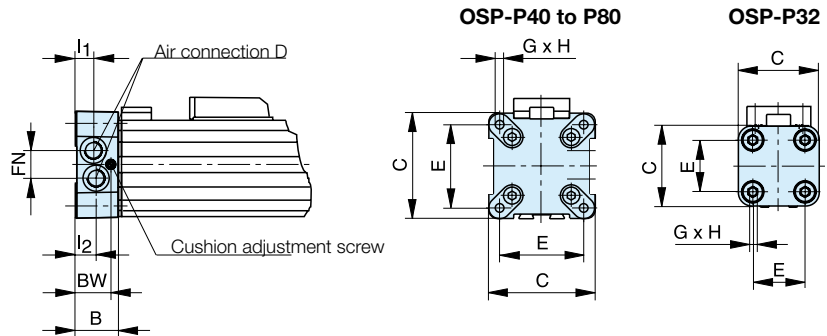

Dimensions [mm]

Series	B	C	D	E	G	H	I ₁	I ₂	BX	BW	EN	EN ₁	EN ₂	FA	FB	FC	FE	FG	FL	FN
OSP-P16	14	30	M5	18	M3	9	5.5	-	1.8	10.8	3	-	-	12.6	12.6	4	27	21	36	-
OSP-P25	22	41	G1/8	27	M5	15	9	-	2.2	17.5	-	3.6	3.9	-	-	-	-	-	-	-
OSP-P32	25.5	52	G1/8	36	M6	15	12.2	10.5	-	20.5	-	-	-	-	-	-	-	-	-	15.2
OSP-P40	28	69	G1/8	54	M6	15	12	12	-	21	-	-	-	-	-	-	-	-	-	17
OSP-P50	33	87	G1/4	70	M6	15	14.5	14.5	-	27	-	-	-	-	-	-	-	-	-	22
OSP-P63	38	106	G3/8	78	M8	21	16.5	13.5	-	30	-	-	-	-	-	-	-	-	-	25
OSP-P80	47	132	G1/2	96	M10	25	22	17	-	37.5	-	-	-	-	-	-	-	-	-	34.5

**Integrated 3/2 Way Valves VOE
Series OSP-P25, P32, P40 and P50**



For optimal control of the OSP-P cylinder, 3/2 way valves integrated into the cylinder's end caps can be used as a compact and complete solution. They allow for easy positioning of the cylinder, smooth operation at the lowest speeds and fast response, making them ideally suited for the direct control of production and automation processes.



Features:

- Complete compact solution
- Various connection possibilities:
Free choice of air connection with rotating end caps with VOE valves, Air connection can be rotated 4 x 90°
- Solenoid can be rotated 4 x 90°,
- Pilot valve can be rotated 180°
- High piston velocities can be achieved with max. 3 exhaust ports
- Minimal installation requirements
- Requires just one air connection per valve
- Optimal control of the OSP-P cylinder
- Excellent positioning characteristics
- Integrated operation indicator
- Integrated exhaust throttle valve
- Manual override - indexed
- Adjustable end cushioning
- Easily retrofitted – please note the increase in the overall length of the cylinder!

Characteristics 3/2 Way Valves VOE

Characteristics 3/2 Way Valves with spring return

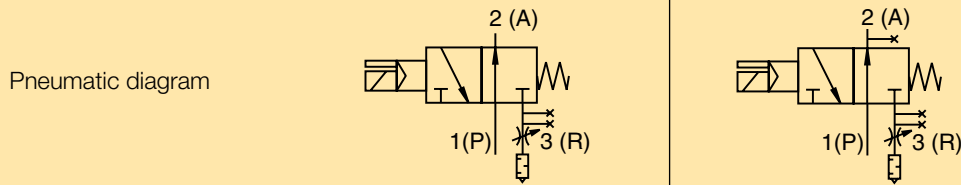

Type	VOE-25	VOE-32	VOE-40	VOE-50
Actuation	electrical			
Basic position	P → A open, R closed			
Type	Poppet valve, non overlapping			
Mounting	integrated in end cap			
Installation	in any position			
Port size	G 1/8	G 1/4	G 3/8	G 3/8
Temperature	-10°C to +50°C *			
Operating pressure	2-8 bar			
Nominal voltage	24 V DC / 230 V AC, 50 Hz			
Power consumption	2.5 W / 6 VA			
Duty cycle	100%			
Electrical Protection	IP 65 DIN 40050			

* other temperature ranges on request

For further technical information see catalogue P-A4P011GB



OSP-P Modular Pneumatic Linear Drive Systems

Dimensions - VOE Valves OSP-P25 and P32

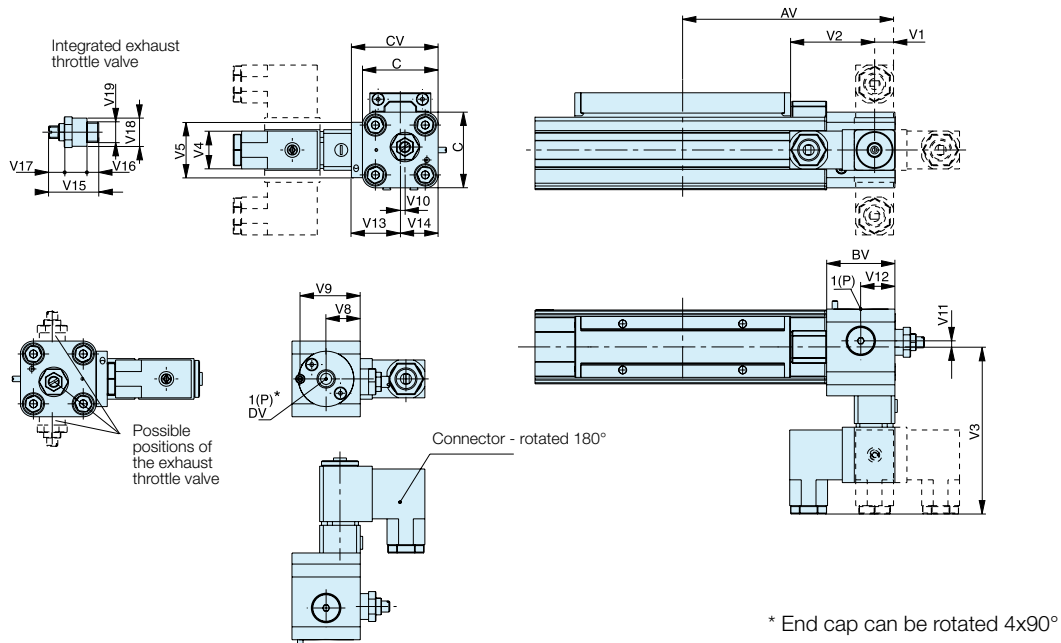

Dimensions [mm]

Series	AV	BV	C	CV	DV	V1	V2	V3	V4	V5	V8	V9	V10	V11	V12	V13	V14	V15	V16	V17	V18	V19
OSP-P25	115	37	41	47	G1/8	11	46	90.5	22	30	18.5	32.5	2.5	3.3	18.5	26.5	20.5	24	5	4	14	G1/8
OSP-P32	139	39.5	52	58	G1/4	20.5	46	96	22	32	20.5	34.7	6	5	20.5	32	26	32	7.5	6	18	G1/4

Dimensions - VOE Valves OSP-P40 and P50

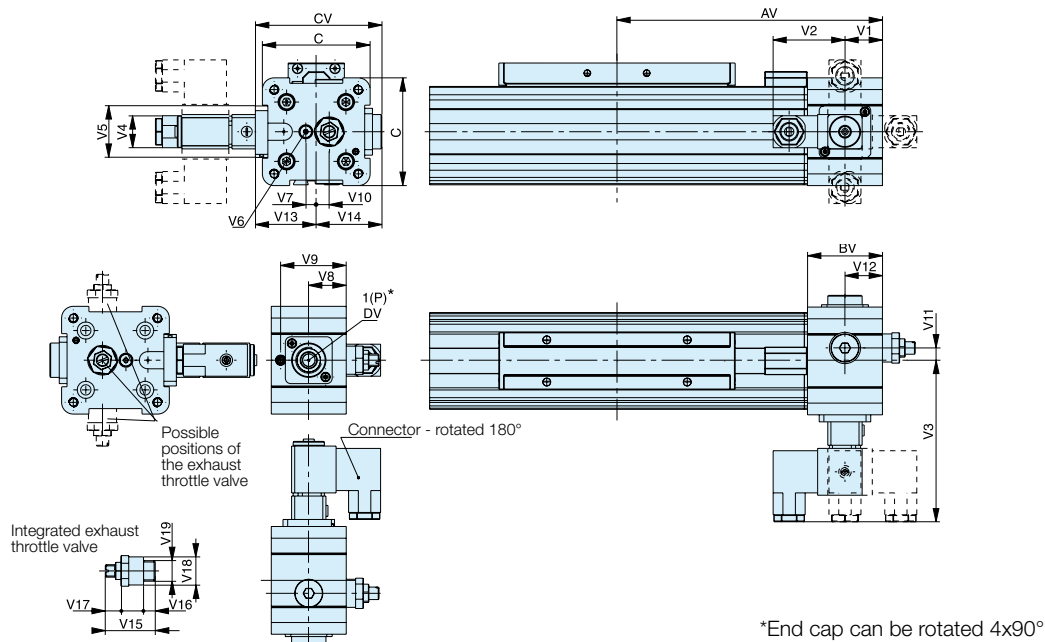

Dimensions [mm]

Series	AV	BV	C	CV	DV	V1	V2	V3	V4	V5	V6	V7	V8	V9	V10	V11	V12	V13	V14	V15	V16	V17	V18	V19
OSP-P40	170	48	69	81	G3/8	24	46	103	22	33	M5	6.7	24	42	8.3	8.3	24	39	42	32	7.5	6	18	G1/4
OSP-P50	190	48	87	82	G3/8	24	46	102	22	33	M5	4.5	24	42	12.2	12.2	24	38	44	32	7.5	6	18	G1/4



Order Instructions - Basic Cylinder

1-4	5+6	7	8	9	10	11	12-16	17	18	19	20	21	22	23	24	25
OSP	25	0	0	0	0	0	01100	0	0	0	0	0	0	0	0	0

Piston-Ø		Stroke Length		Piston Mounting		add. Guide Carriage		Measuring system	
10		In mm (5 digits)		0 without		0 without		0 without	
16				1 clevis mounting				X SFI 0.1 mm	
25								Y SFI 1 mm	
32									
40									
50									
63									
80									

Screws		Cushioning		Version / Piston		Lubrication		End cap position		Guides/ Brakes/ Inversion		Cover / Cable Channel	
0 standard		0 standard		0 standard		0 standard		0 l+r 0° = in front		0 without		0 standard	
1 Stainless		1 max. length ³⁾		1 Tandem		1 slow speed ^{2,3)}		1 l+r 90° = underneath		A Activebrake AB Ø25-80		1 Cable channel	
								2 l+r 180° = at the back		M Inversion Ø16-80		2 Cable channel two-sided	
								3 l+r 270° = same side as outerband		N Duplex Ø25,32,40,50		X without cover rail	

Air Connection		Seals	
0 standard		0 standard (NBR)	
1 end face		1 Viton ^{®1)}	
2 both at one end			
3 left stand. right end face			
4 right stand. left end face			
A 3/2 Way valve VOE24 V = Ø25,32,40,50			
B 3/2 Way valve VOE230 V~/110 V= Ø25,32,40,50			
C 3/2 Way valve VOE48 V = Ø25,32,40,50			
E 3/2 Way valve VOE110 V~ Ø25,32,40,50			

End cap position	
0	l+r 0° = in front
1	l+r 90° = underneath
2	l+r 180° = at the back
3	l+r 270° = same side as outerband
4	l 90° = underneath; r 0° = in front
5	l 180° = at the back; r 0° = in front
6	l 270° = same side as outerband; r 0° = in front
7	l 0° = in front; r 90° = underneath
8	l 180° = at the back; r 90° = underneath
9	l 270° = same side as outerband; r 90° = underneath
A	l 0° = in front; r 180° = at the back
B	l 90° = underneath; r 180° = at the back
C	l 270° = same side as outerband; r 180° = at the back
D	l 0° = in front; r 270° = same side as outerband
E	l 90° = underneath; r 270° = same side as outerband
F	l 180° = at the back; r 270° = same side as outerband

End cap position (air connection)

Cylinder L (left end side)

Cylinder R (right end side)

¹⁾ Viton with VOE not available.

²⁾ Slow speed lubrication in combination with Viton® seals on demand

³⁾ „Lubrication slow speed“ in combination with „max. cushioning length“ not possible.

Accessories - please order separately

Description	Further information see
End Cap Mountings	Page 97
Mid-Section Support	Page 98
Adaptor Profile	Page 109
T-Slot Profile	Page 110
Multiplex Connection	Page 113
Magnetic Switches	Page 114



OSP-P Modular Pneumatic Linear Drive Systems

Long Stroke Cylinder Ø 50-80 mm for strokes up to 41 m

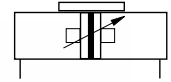

Standard Versions:

- Double-acting with adjustable end cushioning
- With magnetic piston for position sensing

Special Versions:

- Stainless steel screws
- Slow speed lubrication
- Viton® seals

Options:

- Displacement measuring system SFI-plus
- Active brake AB..

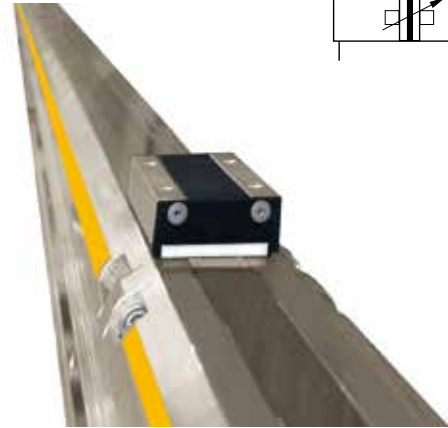

Size Comparison

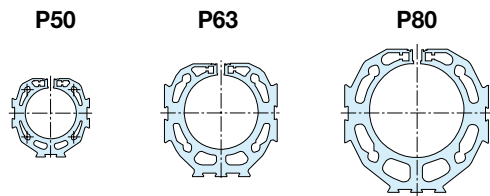

Weight (mass) [kg]

Cylinder series (Basic cylinder)	Weight (Mass) [kg]	
	At 0 mm stroke	per 100 mm stroke
OSP-P50LS	3.53	0.566
OSP-P63LS	6.41	0.925
OSP-P80LS	12.46	1.262

Characteristics	Description
General Features	
Type	Rodless cylinder
Series	OSP-P
System	Double-acting, with cushioning, position sensing capability
Mounting	See drawings
Air Connection	Threaded
Ambient temperature range	T_{min} 10 °C Other temperature ranges T_{max} +40 °C on request
Installation	Vertical, horizontal (piston at top or at bottom)
Medium	Filtered, unlubricated compressed air (other media on request)
Lubrication	Permanent grease lubrication (additional oil mist lubrication not required) Option: special slow speed grease
Material	
Cylinder Profile	Anodized aluminium
Carrier (piston)	Anodized aluminium
End caps	Anodized aluminium
Sealing bands	Corrosion resistant steel
Seals	NBR (Option: Viton®)
Screws	Galvanized steel Option: stainless steel
Dust covers, wipers	Plastic
Max. operating pressure p_{max}	8 bar
Max. speed v	2 m/s

For further technical information see catalogue P-A4P011GB

Loads, Forces and Moments

Choice of cylinder is decided by:

- Permissible loads, forces and moments
- Performance of the pneumatic end cushions.

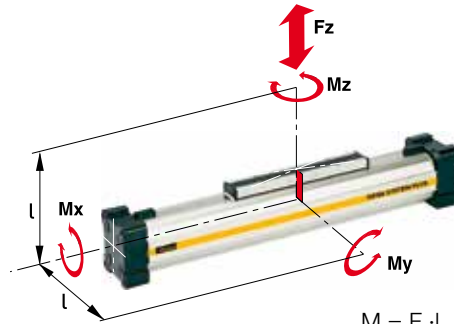

$M = F \cdot l$
 Bending moments are calculated from the centre of the linear actuator

The main factors here are the mass to be cushioned and the piston speed at start of cushioning (unless external cushioning is used, e. g. hydraulic shock absorbers).

The adjacent table shows the maximum values for light, shock-free operation, which must not be exceeded even in dynamic operation. Load and moment data are based on speeds $v \leq 0.5$ m/s.

When working out the action force required, it is essential to take into account the friction forces generated by the specific application or load.

Cylinder-Series Ø [mm]	Theoretical Action Force at 6 bar [N]	effektive Action Force F_A at 6 bar [N]	max. Moments			max. Load F [N]	Cushion Length [mm]
			M_x [Nm]	M_y [Nm]	M_z [Nm]		
OSP-P50LS	1178	1000	10	115	15	1200	30
OSP-P63LS	1870	1550	12	200	24	1650	32
OSP-P80LS	3016	2600	24	360	48	2400	39

Cushioning Diagram

Work out your expected moving mass and read off the maximum permissible speed at start of cushioning. Alternatively, take your desired speed and expected mass and find the cylinder size required. Please note that piston speed at start of cushioning is typically ca. 50 % higher than the average speed, and that it is this higher speed which determines the choice of cylinder. If these maximum permissible values are exceeded, additional shock absorbers must be used.

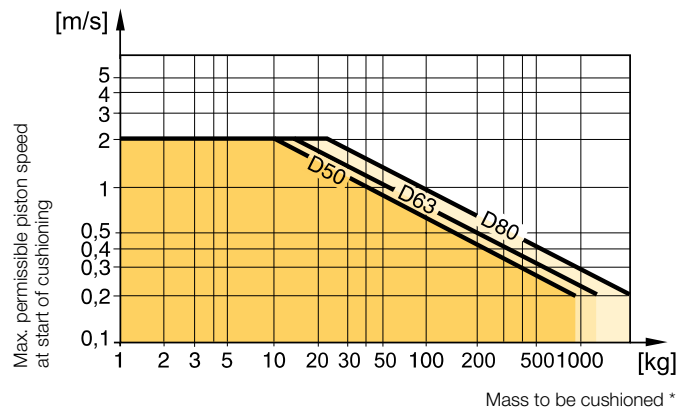

Horizontal application, pressure $p = 6$ bar

* For cylinders with brakes, please be sure to take the mass of the brake housing into account.

If the permitted limit values are exceeded, additional shock absorbers should be fitted in the area of the centre of gravity.

**Cylinder
Stroke and Dead Length A**

- Free choice of stroke length up to 41.000 mm in 1 mm steps.

Dimensions of Basic Cylinder OSP-P50LS to P80LS

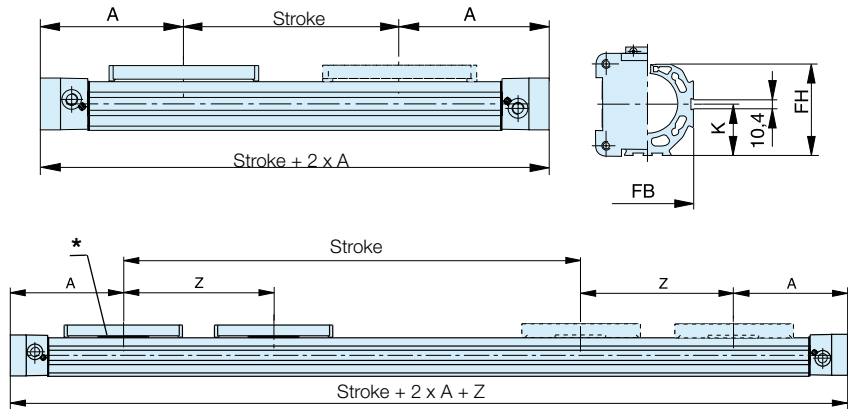

Tandem Cylinder

Two pistons are fitted: dimension "Z" is optional.
(Please note minimum distance "Zmin").

- Free choice of stroke length up to 41.000 mm in 1 mm steps
- Stroke length to order is stroke + dimension "Z"

Please note:

To avoid multiple actuation of magnetic switches, the second piston is not equipped with magnets.

* Piston with magnet

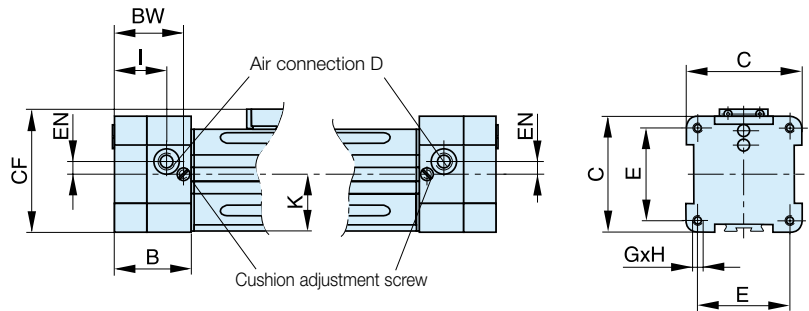

Note: End caps are not turnable.

**Carrier
Series OSP-P50LS to P80LS**

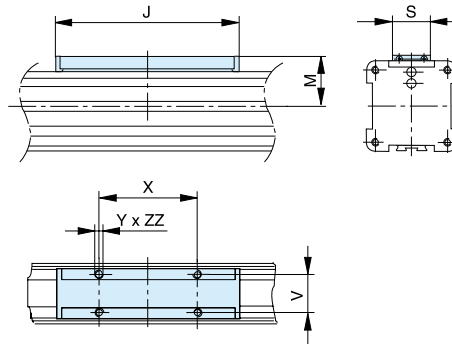

Dimensions [mm]

Series	A	B	C	D	E	G	H	I	J	K	M	S	V	X	Y	Z _{min}	BW	CF	EN	FB	FH	ZZ
OSP-P50LS	200	58	87	G1/4	70	M6	15	39.5	200	43	49	36	27	110	M6	251	52	92.5	10	76	77	10
OSP-P63LS	250	73	106	G3/8	78	M8	21	49.5	256	54	63	50	34	140	M8	313	65	117	12	96	96	16
OSP-P80LS	295	82	132	G1/2	96	M10	25	57	348	67	80	52	36	190	M10	384	72.5	147	16.5	122	122	20

OSP-P Modular Pneumatic Linear Drive Systems

Linear Drive Accessories Ø 50-80 mm Mid-Section Support E1, E1L



For Linear Drive:

- Series OSP-P..LS

Note on Types E1 and E1L (P50LS – P80LS):

The mid-section support can also be mounted on the underside of the actuator, in which case its distance from the centre of the actuator is different.

For mounting the Long-Stroke cylinder, a mid-section support Type E1 (fixed support) is required. Depending on the stroke length and the load, additional E1L supports (movable supports) may be required.

For permissible support spacings see diagram.

Stainless steel version on request.

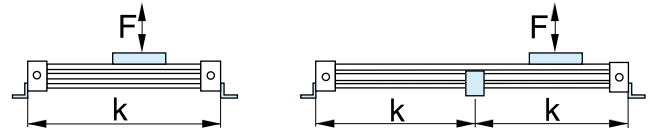

Permissible Support Spacings: OSP - P50LS to P80LS

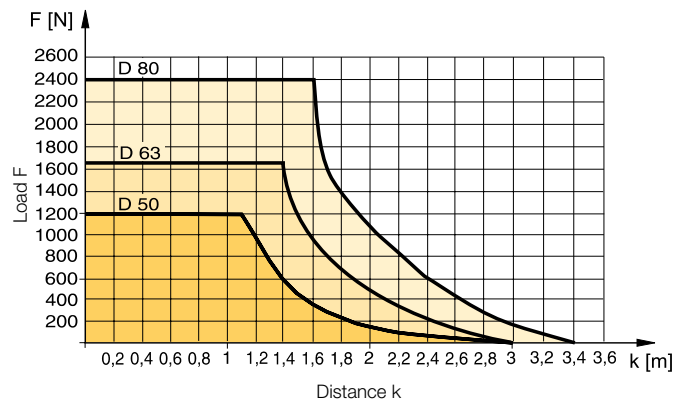

Series OSP-P50LS to P80LS: Type E1, E1L (Mounting from above / below using a cap screw)

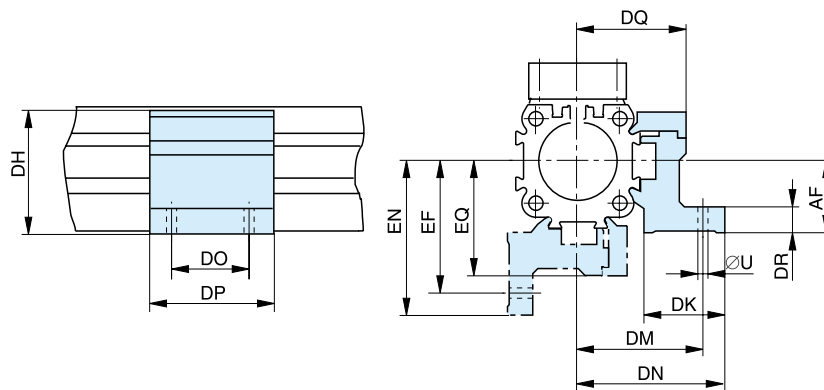

Dimensions [mm] - Series OSP-P50LS to P80LS

Series	R	U	AF	DF	DH	DK	DM	DN	DO	DP	DQ	DR	DT	EF	EM	EN	EQ	Order No. Type E1 fixed support	Order No. Type E1L movable support
OSP-P50LS	M6	7	48	40	71	34	59	67	45	60	52	10	11	64	45	72	57	20163FIL	21352FIL
OSP-P63LS	M8	9	57	47.5	91	44	73	83	45	65	63	12	16	79	53.5	89	69	20452FIL	21353FIL
OSP-P80LS	M10	11	72	60	111.5	63	97	112	55	80	81	15	25	103	66	118	87	20482FIL	21354FIL



Order Instructions - Long Stroke Cylinder**Note:**

Assembly and commissioning of the Long-Stroke cylinder is carried out on site by ORIGA technical personnel.

For more information on ordering and installation please contact your sales or customer service partner.

Accessories - please order separately

Description	Further information see
Clevis Mounting	Page 92
End Cap Mountings	Page 93
Mid-Section Support	Page 94
Inversion Mounting	Page 104
Adaptor Profile	Page 105
T-Slot Profile	Page 106
Connection Profile	Page 107
Magnetic Switches	Page 110
Cable Cover	Page 117

OSP-P Modular Pneumatic Linear Drive Systems

Clean Room Cylinder Ø 16-32 mm Certified to DIN EN ISO 14644-1

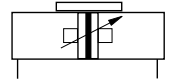

Standard Versions:

- Double-acting with adjustable end cushioning
- With magnetic piston for position sensing
- Stainless steel screws

Special Versions:

- Slow speed lubrication
- Viton® seals

Features:

- Clean room classification
ISO Class 4 at $v_m = 0.14$ m/s
ISO Class 5 at $v_m = 0.5$ m/s
- Suitable for smooth slow speed operation down to $v_{min} = 0.005$ m/s
- Optional stroke length up to 1200 mm (longer strokes on request)
- Low maintenance
- Compact design with equal force and velocity in both directions
- Aluminium piston with bearing rings to support high direct and cantilever loads



Size Comparison

P16



P25



P32



Weight (mass) [kg]

Cylinder series (Basic cylinder)	Weight (Mass) [kg]	
	At 0 mm stroke	per 100 mm stroke
OSP-P16	0.22	0.1
OSP-P25	0.65	0.197
OSP-P32	1.44	0.354

Characteristics	Description
General Features	
Type	Rodless cylinder
Series	OSP-P
System	Double-acting, with cushioning, position sensing capability
Mounting	See drawings
Air Connection	Threaded
Ambient temperature range	T_{min} -10 °C Other temperature ranges T_{max} +80 °C on request
Installation	In any position
Medium	Filtered, unlubricated compressed air (other media on request)
Lubrication	Permanent grease lubrication (additional oil mist lubrication not required) Option: special slow speed grease
Material	
Cylinder Profile	Anodized aluminium
Carrier (piston)	Anodized aluminium
End caps	Aluminium, lacquered
Sealing bands	Corrosion resistant steel
Seals	NBR (Option: Viton®)
Screws	Stainless steel
Covers	Anodised aluminium
Guide plate	Plastic
Max. operating pressure p_{max}	8 bar

Certification

Based on the Parker Origa rodless cylinder, proven in world wide markets, Parker Origa now offers the only rodless cylinder on the market with a certification from IPA Institute for the cleanroom specification according to DIN EN ISO 14644-1.



Function

The clean room cylinders of the ORIGA SYSTEM PLUS (OSP-P) combines the efficiency of the Parker Origa slot seal system with vacuum protection against progressive wear and contamination from the sliding components. A partial vacuum drawn between inner and outer sealing bands prevents emission into the clean room. To achieve the necessary vacuum a suction flow of ca. 4 m³/h is required.

Function Diagram

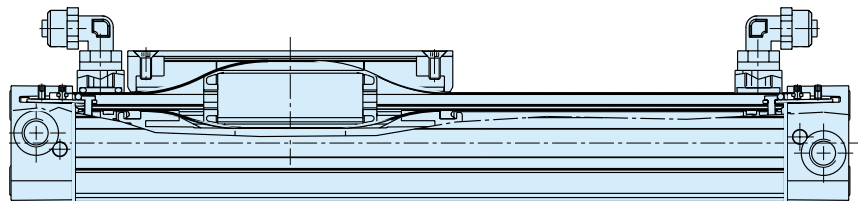

Loads, Forces and Moments

Load and moment data are based on speeds $v \leq 0.2$ m/s. The adjacent table shows the maximum values for light, shock-free operation which must not be exceeded even in dynamic operation.

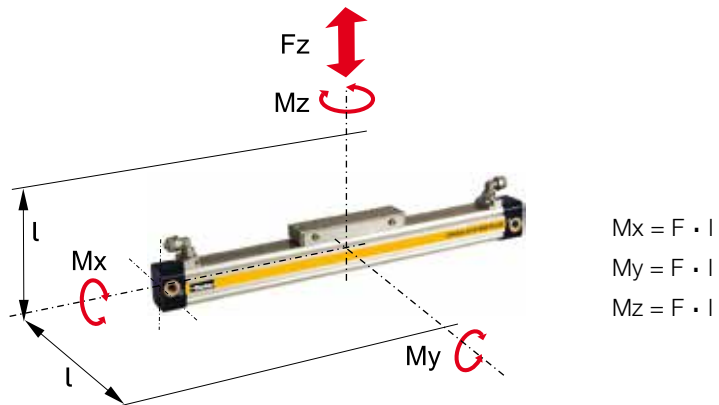

Series	Effective Force at 6 bar [N]	Max. Moment			Max. Load Fz [N]	Cushion Length [mm]
		Mx [Nm]	My [Nm]	Mz [Nm]		
OSP-P16	78	0.45	4	0.5	120	11
OSP-P25	250	1.5	15	3.0	300	17
OSP-P32	420	3.0	30	5.0	450	20

OSP-P Modular Pneumatic Linear Drive Systems

Dimensions [mm]

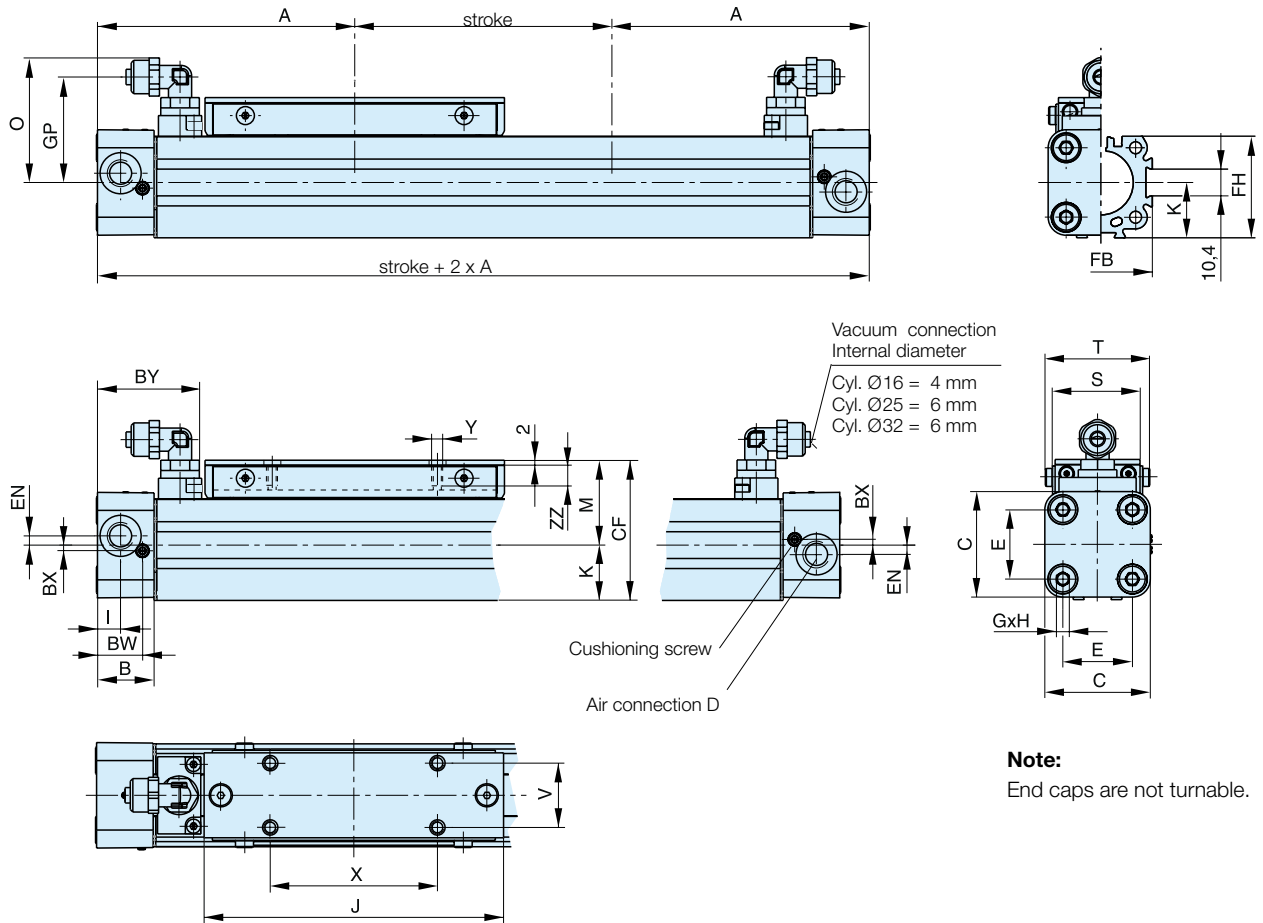

Dimensions [mm]

Series	A	B	C	D	E	G	H	I	J	K	M	O	S
OSP-P16	65	14	30	M5	18	M3	9	5.5	69	15	25	31	24
OSP-P25	100	22	41	G1/8	27	M5	15	9	117	21.5	33	48.5	35
OSP-P32	125	25.5	52	G1/4	36	M6	15	11.5	152	28.5	40	53.6	38

Series	T	V	X	Y	BW	BX	BY	CF	EN	FB	FH	GP	ZZ
OSP-P16	29.6	16.5	36	M4	10.8	1.8	28.5	40	3	30	27.2	25.7	7
OSP-P25	40.6	25	65	M5	17.5	2.2	40.5	54.5	3.6	40	39.5	41	8
OSP-P32	45	27	90	M6	20.5	2.5	47.1	68.5	5.5	52	51.7	46.2	10

Order Instructions - Clean Room Cylinder

1-4	5+6	7	8	9	10	11	12-16	17	18	19	20	21	22	23	24	25
OSP	25	4	7	0	0	1	01100	0	0	0	0	0	0	0	0	0

Piston-Ø
 16
 25
 32

Stroke Length
 in mm
 (5 digits)²⁾

Piston Mounting
 0 without

add. Guide Carriage
 0 without

Measuring system
 0 without

Screws
 1 Stainless

Cushioning
 0 Standard

Version / Piston
 4 Clean room

Lubrication
 0 Standard
 1 Slow speed¹⁾

End cap position
 0 L+R 0° = in front

Guides/ Brakes/ Inversion
 0 without

Cover / Cable Channel
 0 Standard
 1 Cable channel
 2 Cable channel two-sided
 X without Cover rail

Air Connection
 7 End cap
 Clean room

Seals
 0 Standard (NBR)
 1 Viton®

¹⁾ The combination „Slow speed lubrication“ and „Viton®“ sealings“ are available on request.
²⁾ max. stroke lengths 1200 mm, longer strokes on request.

Accessories - please order separately

Description	Further information see
End Cap Mountings	Page 93
Mid-Section Support	Page 94
Adaptor Profile	Page 105
T-Slot Profile	Page 106
Connection Profile	Page 107
Magnetic Switches	Page 110

Components for EX-Areas

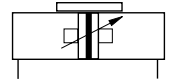

Information for ATEX-Directives

The rodless pneumatic cylinders of Parker Origa are the first linear drive unit, for that Ex range in the group of equipment II, Category 2 GD are certified.

Detail informations for use pneumatic components in Ex-Areas see leaflet PDE2584TCUK „EU Directive 94/9/EG (ATEX 95) for Pneumatic Components“.

Rodless Cylinder Ø 10-80 mm

Basic Cylinder - Series: OSP-P .. ATEX



BASIC GUIDE Ø 25-50 mm

Basic Guide - Series: BG .. ATEX



Plain Bearing Guide Ø 16-80 mm

SLIDELINE - Series: SL .. ATEX



Technical Data (deviant to the Standard Cylinder)

Characteristics	Description
General Features	
Ambient temperature range T_{min} / T_{max}	-10 °C / +60 °C
Max. switching frequency	1 (double stroke/s) Basic cylinder 0.5 (1stroke/s) Cylinder with guide
Operating pressure range p_{max}	Max. 8 bar
Max. speed v_{max}	3 (Basic cylinder) 2 (Cylinder with guide SLIDELINE and cylinder with guide BASIC GUIDE)
Medium	Filtered, unlubricated compressed air – free from water and dirt to ISO 8573-1 Solids: Class 7 particle size < 40 µm for Gas Water content: pressure dew point +3 °C, class 4, but at least 5 °C below minimum operating temperature
Noise level	70 dB (A)
Information for materials	
Aluminium	See data sheet "Material"
Lubrication	See security data sheet "Grease for use in Cylinder with guides"
Sealing bands	Corrosion resistant steel

Equipment Group II Categorie 2GD

Rodless cylinder: II 2GD c T4 T135°C -10°C ≤ Ta ≤ +60°C

Series	Size	Stroke range	Accessories
OSP-P	Ø 10 to 80	1– 6000 mm	Mountings programme
BASIC GUIDE	Ø 25 to 50	1– 6000 mm	Mountings programme
SLIDELINE	Ø 16 to 80	1– 5500 mm	Mountings programme

Order Instructions - ATEX Cylinder *

1-4	5+6	7	8	9	10	11	12-16	17	18	19	20	21	22	23	24	25
OSPP	25	0	0	0	0	0	01100	0	0	0	0	0	0	0	0	0

<table border="1" style="width:100%; border-collapse: collapse;"> <tr><th style="text-align: left;">Piston-Ø</th></tr> <tr><td>10</td></tr> <tr><td>16</td></tr> <tr><td>25</td></tr> <tr><td>32</td></tr> <tr><td>40</td></tr> <tr><td>50</td></tr> <tr><td>63</td></tr> <tr><td>80</td></tr> </table> <table border="1" style="width:100%; border-collapse: collapse;"> <tr><th style="text-align: left;">Version / Piston</th></tr> <tr><td>6 ATEX standard</td></tr> </table> <table border="1" style="width:100%; border-collapse: collapse;"> <tr><th style="text-align: left;">Air Connection</th></tr> <tr><td>0 Standard</td></tr> <tr><td>1 end face</td></tr> <tr><td>2 both at one end (not turnable)</td></tr> <tr><td>3 left stand. right end face</td></tr> <tr><td>4 right stand. left end face</td></tr> </table>	Piston-Ø	10	16	25	32	40	50	63	80	Version / Piston	6 ATEX standard	Air Connection	0 Standard	1 end face	2 both at one end (not turnable)	3 left stand. right end face	4 right stand. left end face	<table border="1" style="width:100%; border-collapse: collapse;"> <tr><th style="text-align: left;">Stroke Length</th></tr> <tr><td>In mm (5 digits)</td></tr> </table> <table border="1" style="width:100%; border-collapse: collapse;"> <tr><th style="text-align: left;">Screws</th></tr> <tr><td>0 standard</td></tr> <tr><td>1 stainless</td></tr> </table> <table border="1" style="width:100%; border-collapse: collapse;"> <tr><th style="text-align: left;">Lubrication</th></tr> <tr><td>0 standard</td></tr> <tr><td>1 slow speed²⁾³⁾</td></tr> </table> <table border="1" style="width:100%; border-collapse: collapse;"> <tr><th style="text-align: left;">Seals</th></tr> <tr><td>0 standard (NBR)</td></tr> <tr><td>1 Viton®¹⁾</td></tr> </table>	Stroke Length	In mm (5 digits)	Screws	0 standard	1 stainless	Lubrication	0 standard	1 slow speed ²⁾³⁾	Seals	0 standard (NBR)	1 Viton® ¹⁾	<table border="1" style="width:100%; border-collapse: collapse;"> <tr><th style="text-align: left;">End cap position</th></tr> <tr><td>0 l+r 0° = in front</td></tr> <tr><td>1 l+r 90° = underneath</td></tr> <tr><td>2 l+r 180° = at the back</td></tr> <tr><td>3 l+r 270° = same side as outerband</td></tr> <tr><td>4 l 90° = underneath; r 0° = in front</td></tr> <tr><td>5 l 180° = at the back; r 0° = in front</td></tr> <tr><td>6 l 270° = same side as outerband; r 0° = in front</td></tr> <tr><td>7 l 0° = in front; r 90° = underneath</td></tr> <tr><td>8 l 180° = at the back; r 90° = underneath</td></tr> <tr><td>9 l 270° = same side as outerband; r 90° = underneath</td></tr> <tr><td>A l 0° = in front; r 180° = at the back</td></tr> <tr><td>B l 90° = underneath; r 180° = at the back</td></tr> <tr><td>C l 270° = same side as outerband; r 180° = at the back</td></tr> <tr><td>D l 0° = in front; r 270° = same side as outerband</td></tr> <tr><td>E l 90° = underneath; r 270° = same side as outerband</td></tr> <tr><td>F l 180° = at the back; r 270° = same side as outerband</td></tr> </table>	End cap position	0 l+r 0° = in front	1 l+r 90° = underneath	2 l+r 180° = at the back	3 l+r 270° = same side as outerband	4 l 90° = underneath; r 0° = in front	5 l 180° = at the back; r 0° = in front	6 l 270° = same side as outerband; r 0° = in front	7 l 0° = in front; r 90° = underneath	8 l 180° = at the back; r 90° = underneath	9 l 270° = same side as outerband; r 90° = underneath	A l 0° = in front; r 180° = at the back	B l 90° = underneath; r 180° = at the back	C l 270° = same side as outerband; r 180° = at the back	D l 0° = in front; r 270° = same side as outerband	E l 90° = underneath; r 270° = same side as outerband	F l 180° = at the back; r 270° = same side as outerband	<table border="1" style="width:100%; border-collapse: collapse;"> <tr><th style="text-align: left;">Piston Mounting</th></tr> <tr><td>0 without</td></tr> <tr><td>1 clevis mounting Ø 16-80</td></tr> </table> <table border="1" style="width:100%; border-collapse: collapse;"> <tr><th style="text-align: left;">Cushioning</th></tr> <tr><td>0 standard</td></tr> <tr><td>1 max. length³⁾</td></tr> </table> <table border="1" style="width:100%; border-collapse: collapse;"> <tr><th style="text-align: left;">add. Guide Carriage</th></tr> <tr><td>0 without</td></tr> <tr><td>2 Guide Carriage Slideline SL Ø 16-80</td></tr> </table> <table border="1" style="width:100%; border-collapse: collapse;"> <tr><th style="text-align: left;">Guides/ Brakes/ Inversion</th></tr> <tr><td>0 without</td></tr> <tr><td>2 Slideline SL Ø 16-80</td></tr> <tr><td>M Inversion</td></tr> </table>	Piston Mounting	0 without	1 clevis mounting Ø 16-80	Cushioning	0 standard	1 max. length ³⁾	add. Guide Carriage	0 without	2 Guide Carriage Slideline SL Ø 16-80	Guides/ Brakes/ Inversion	0 without	2 Slideline SL Ø 16-80	M Inversion	<table border="1" style="width:100%; border-collapse: collapse;"> <tr><th style="text-align: left;">Measuring system</th></tr> <tr><td>0 without</td></tr> </table> <table border="1" style="width:100%; border-collapse: collapse;"> <tr><th style="text-align: left;">Cover / Cable Channel</th></tr> <tr><td>0 standard</td></tr> <tr><td>1 Cable channel</td></tr> <tr><td>2 Cable channel two-sided</td></tr> <tr><td>X without cover rail</td></tr> </table>	Measuring system	0 without	Cover / Cable Channel	0 standard	1 Cable channel	2 Cable channel two-sided	X without cover rail
Piston-Ø																																																																					
10																																																																					
16																																																																					
25																																																																					
32																																																																					
40																																																																					
50																																																																					
63																																																																					
80																																																																					
Version / Piston																																																																					
6 ATEX standard																																																																					
Air Connection																																																																					
0 Standard																																																																					
1 end face																																																																					
2 both at one end (not turnable)																																																																					
3 left stand. right end face																																																																					
4 right stand. left end face																																																																					
Stroke Length																																																																					
In mm (5 digits)																																																																					
Screws																																																																					
0 standard																																																																					
1 stainless																																																																					
Lubrication																																																																					
0 standard																																																																					
1 slow speed ²⁾³⁾																																																																					
Seals																																																																					
0 standard (NBR)																																																																					
1 Viton® ¹⁾																																																																					
End cap position																																																																					
0 l+r 0° = in front																																																																					
1 l+r 90° = underneath																																																																					
2 l+r 180° = at the back																																																																					
3 l+r 270° = same side as outerband																																																																					
4 l 90° = underneath; r 0° = in front																																																																					
5 l 180° = at the back; r 0° = in front																																																																					
6 l 270° = same side as outerband; r 0° = in front																																																																					
7 l 0° = in front; r 90° = underneath																																																																					
8 l 180° = at the back; r 90° = underneath																																																																					
9 l 270° = same side as outerband; r 90° = underneath																																																																					
A l 0° = in front; r 180° = at the back																																																																					
B l 90° = underneath; r 180° = at the back																																																																					
C l 270° = same side as outerband; r 180° = at the back																																																																					
D l 0° = in front; r 270° = same side as outerband																																																																					
E l 90° = underneath; r 270° = same side as outerband																																																																					
F l 180° = at the back; r 270° = same side as outerband																																																																					
Piston Mounting																																																																					
0 without																																																																					
1 clevis mounting Ø 16-80																																																																					
Cushioning																																																																					
0 standard																																																																					
1 max. length ³⁾																																																																					
add. Guide Carriage																																																																					
0 without																																																																					
2 Guide Carriage Slideline SL Ø 16-80																																																																					
Guides/ Brakes/ Inversion																																																																					
0 without																																																																					
2 Slideline SL Ø 16-80																																																																					
M Inversion																																																																					
Measuring system																																																																					
0 without																																																																					
Cover / Cable Channel																																																																					
0 standard																																																																					
1 Cable channel																																																																					
2 Cable channel two-sided																																																																					
X without cover rail																																																																					

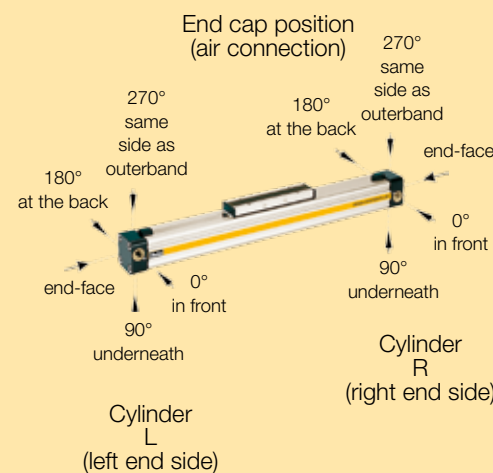

End cap position (air connection)

270° same side as outerband

180° at the back

end-face

0° in front

90° underneath

Cylinder R (right end side)

270° same side as outerband

180° at the back

end-face

0° in front

90° underneath

Cylinder L (left end side)

* Order instructions BASIC GUIDE ATEX-Version see page 36

¹⁾ Slow speed lubrication in combination with Viton® seals on demand.

²⁾ „Lubrication slow speed“ in combination with „max. cushioning length“ not possible.

Accessories - please order separately

Description	Further information see
End Cap Mounting for OSP-P Basic Cylinder	Page 93
End Cap Mounting for OSP-P Basic Cylinder with SLIDELINE	Page 44
Mid-Section Support for OSP-P Basic Cylinder	Page 94
Mid-Section Support for OSP-P Basic Cylinder with SLIDELINE	Page 44
Adaptor Profile	Page 105
T-Slot Profile	Page 106
Magnetic Switches ATEX Version	Page 114

OSP-P Modular Pneumatic Linear Drive Systems

Synchronised Rodless Cylinder Ø 40 mm For synchronised bi-parting movements Type OSP-P40-SL-BP

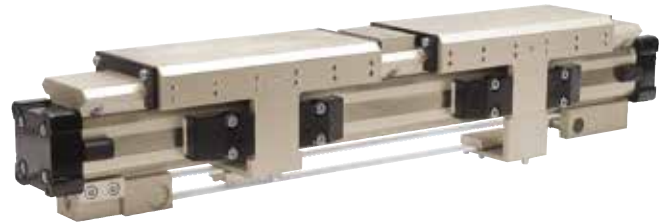

Applications:

- Opening and closing operations
- Gripping of workpieces – outside
- Gripping of hollow workpieces – inside
- Gripping underneath larger objects
- Clamping force adjustable via pressure regulator

Features:

- Accurate bi-parting movement through toothed belt synchronization
- Optimum slow speed performance
- Increased action force
- Anodized aluminium guide rail with prism-form slideway arrangement
- Adjustable polymer slide units
- Combined sealing system with polymer and felt elements to remove dirt and lubricate the slideway
- Integrated grease nipples for guide lubrication

Applications:

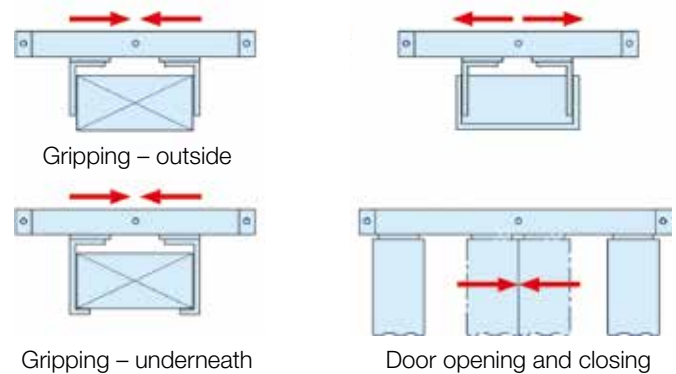

Characteristics	Description	
General Features		
Type	Rodless cylinder for synchronised bi-parting movements	
Series	OSP-P	
System	Double-acting with end cushioning for contactless position sensing	
Guide	Slideline SL40	
Synchronisation	Toothed belt	
Mounting	See drawings	
Ambient temperature range	-10 °C to +60 °C	
Installation	In any position	
Medium	Filtered, unlubricated compressed air (other media on request)	
Lubrication	Special slow speed grease - additional oil mist lubrication not required	
Operating pressure p_{max}	6 bar	
Cushioning middle position	Elastic buffer	
Max. speed v_{max}	0.2 m/s	
Max. stroke of each stroke	500 mm	
Max. mass per guide carrier	25 kg	
Max. moments on guide carrier		
Lateral moment Mx_{max}	25 Nm	
Axial moment My_{max}	46 Nm	
Rotating moment Mz_{max}	46 Nm	
Material		
Toothed belt	Steel-corded polyurethane	
Belt wheel	Aluminium	

OSP-P Modular Pneumatic Linear Drive Systems

Function:

The OSP-P40-SL-BP bidirectional linear drive is based on the OSP-P40 rodless pneumatic cylinder and adapted SLIDELINE SL40 polymer plain-bearing guides.

Two pistons in the cylinder bore are connected via yokes and carriers to the SLIDELINE guide carriers, which handle the forces and moments generated.

The bi-parting movements of the guide carriers are accurately synchronized by a recirculating toothed belt.

The two pistons are driven from the middle to the end positions via a common G1/4 air connection in the middle of the cylinder, and are driven from the end positions to the middle via an air connection in each end cap.

End position cushioning is provided by adjustable air cushioning in the end caps, and middle position cushioning by rubber buffers.

Weight (mass) [kg]

Cylinder series (Basic cylinder)	Weight (mass) [kg]	
	At 0 mm stroke	per 100 mm stroke
OSP-P40-SL-BP	10.33	2.13

Dimensions [mm]

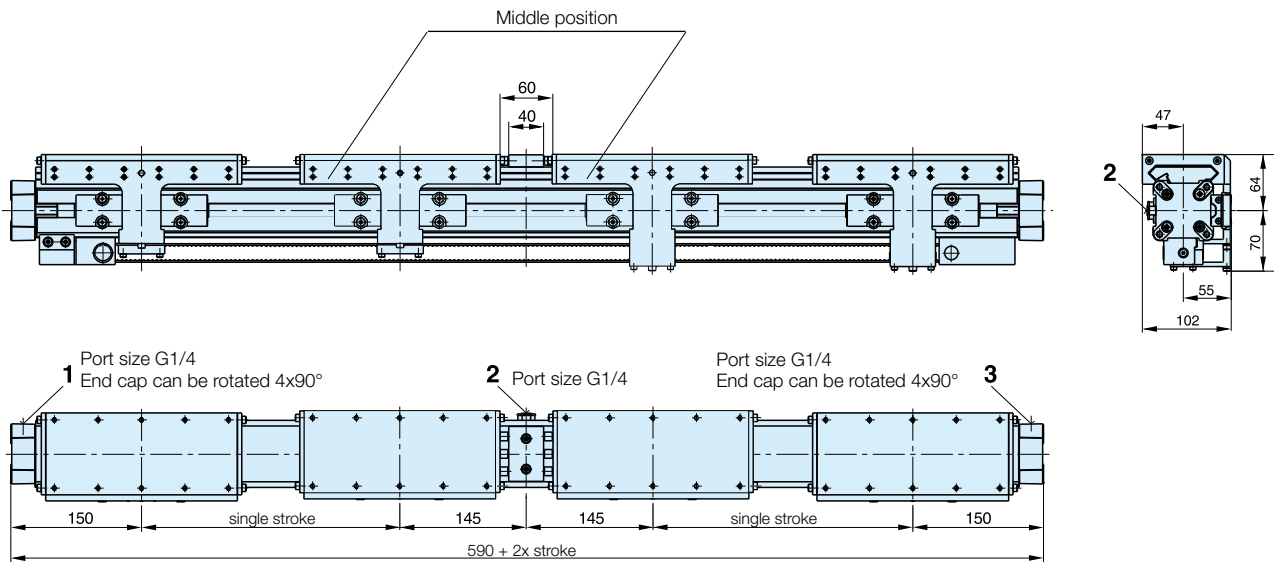

Air connections:

To drive the guide carriers to the middle position: pressurize ports 1 and 3.

To drive the guide carriers to the end positions: pressurize port 2.

Order Instructions

Description	Type	Order No. **
Rodless cylinder for synchronized bi-parting movements	OSP-P40-SL-BP	21315

Note: Order stroke = 2 x single stroke

** Please use this order pattern: Order-No. + „order stroke in mm“ (5 digits)
Example: for single stroke 100 mm = order stroke 2x100 mm = 200 mm: 21315-00200

Plain Bearing BASIC GUIDE
Ø 25-50 mm

Series OSPP-BG

Standard Versions:

- Double-acting with adjustable end cushioning
- With magnetic piston for position sensing

Special Versions:

- Stainless steel screws
- Slow speed lubrication
- Viton® seals
- Both air connections on one end
- Air connection on the end-face
- Integrated Valves VOE

Weight (mass) [kg]

Cylinder series (Basic cylinder)	Weight (mass) [kg]	
	At 0 mm stroke	per 100 mm stroke
OSPP-BG25	1.09	0.22
OSPP-BG32	2.26	0.38
OSPP-BG40	3.52	0.41
OSPP-BG50	5.30	0.58

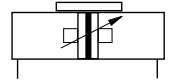

- End cap can be rotated 4 x 90° to position air connection as desired
- Free choice of stroke length up to 6000 mm.

Size Comparison

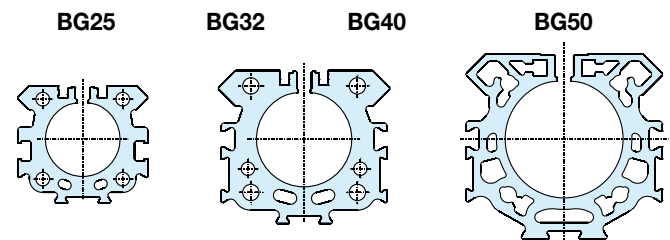

Characteristics	Description
General Features	
Type	Rodless cylinder
Series	OSPP-BG
System	Double-acting, with cushioning, position sensing capability
Mounting	See drawings
Air Connection	Threaded
Ambient temperature range	T_{min} -10 °C Other temperature ranges T_{max} +80 °C on request
Installation	Free
Medium	Filtered, unlubricated compressed air (other media on request)
Lubrication	Permanent grease lubrication (additional oil mist lubrication not required)
Option: special slow speed grease	
Material	
Cylinder Profile	Anodized aluminium
Carrier (piston)	Anodized aluminium
End caps	Al, catalytically coated
Sealing bands	Corrosion resistant steel
Seals	NBR (Option: Viton®)
Screws	Galvanized steel Option: stainless steel
Dust covers, wipers	Plastic
Max. operating pressure p_{max}	8 bar

**Plain Bearing Guide
BASIC GUIDE**

**Series BG 25 to 50 for Linear Drive
Compact, robust plain bearing guide
for medium loads**

Features:

- Compact: guide rail integrated in cylinder profile tube
- Robust: wiper system and grease nipples for long service life
- smooth operation
- simple to (re-) adjust
- Integrated grease nipples
- Any length of stroke up to 6000 mm (longer strokes on request)



Options:

- Corrosion resistant version available on request
- VOE-Valves

Accessories:

- Mid-Section Support
- End Cap Mountings
- Magnetic Switches

Loads, Forces and Moments

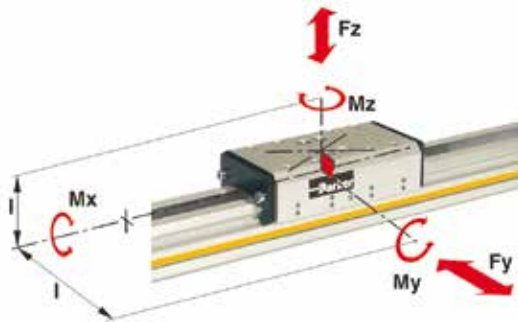

Technical Data

The table shows the maximum permissible values for smooth operation, which should not be exceeded even under dynamic conditions.

The load and moment figures apply to speeds $v < 0.2$ m/s.

*** Please note:**

In the cushioning diagram, add the mass of the guide carriage to the mass to be cushioned.

$$\frac{M_x}{M_{x_{max}}} + \frac{M_y}{M_{y_{max}}} + \frac{M_z}{M_{z_{max}}} + \frac{F_y}{F_{y_{max}}} + \frac{F_z}{F_{z_{max}}} \leq 1$$

The sum of the loads should not exceed >1.

Series	Max. Moments [Nm]			Max. Load [Nm]	Mass of Basic Guide [kg]		Mass* of guide carriage [kg]	Cushion Length [mm]
	Mx	My	Mz		Fy, Fz	at 0mm stroke		
BG25	10	28	28	590	1.09	0.22	0.29	17
BG32	17	43	43	850	2.26	0.38	0.69	20
BG40	39	110	110	1600	3.52	0.41	1.37	27
BG50	67	165	165	2000	5.30	0.58	1.91	30

Loads, Forces and Moments

Composite sealing system with high-tech polymer and felt wiper elements to remove dirt and lubricate the slideways.

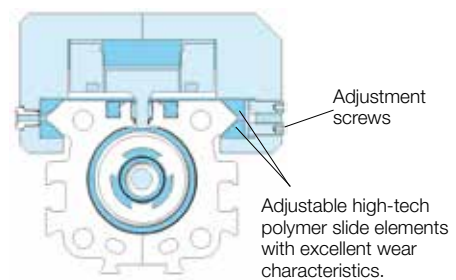
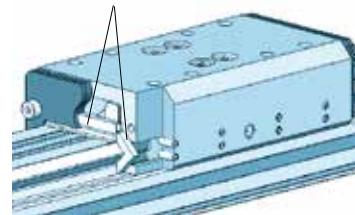

Mid-Section Support

Mid-section supports are required from a certain stroke length to prevent excessive deflection and vibration of the linear drive. The diagrams show the maximum permissible unsupported length in relation to loading. A distinction must be drawn between loading 1 and loading 2. Deflection of 0.5 mm max. between supports is permissible.

Note:

For speeds $v > 0.5$ m/s the distance between supports should not exceed 1 m.

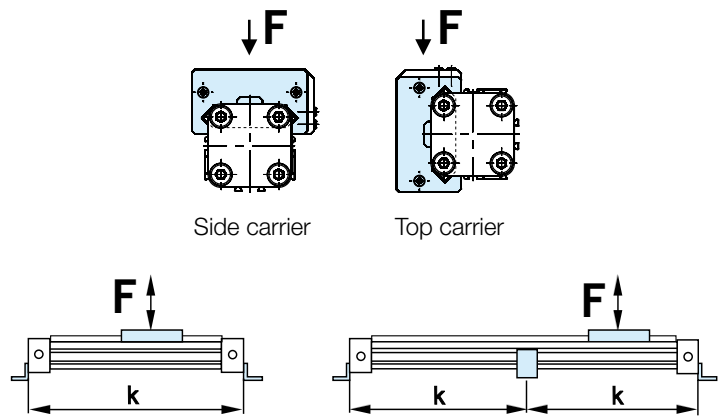

Permissible unsupported length: BG25, BG32

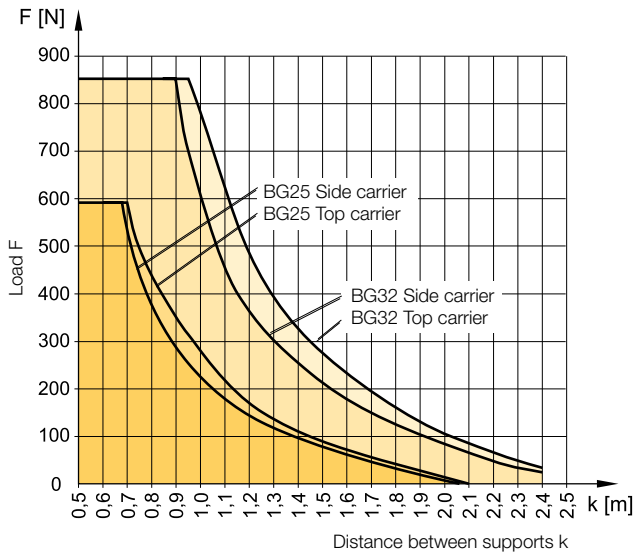

Permissible unsupported length BG40, BG50

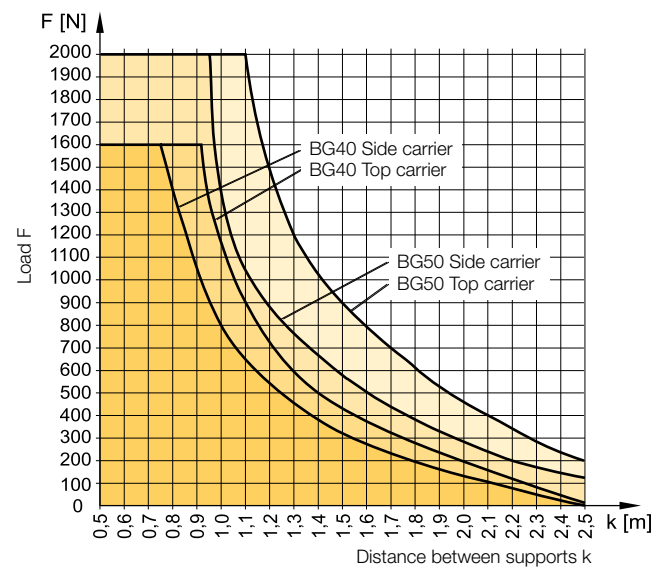

Cushioning Diagram

Work out your expected moving mass and read off the maximum permissible speed at start of cushioning. Alternatively, take your desired speed and expected mass and find the cylinder size required. Please note that piston speed at start of cushioning is typically approx. 50 % higher than the average speed, and that it is this higher speed which determines the choice of cylinder.

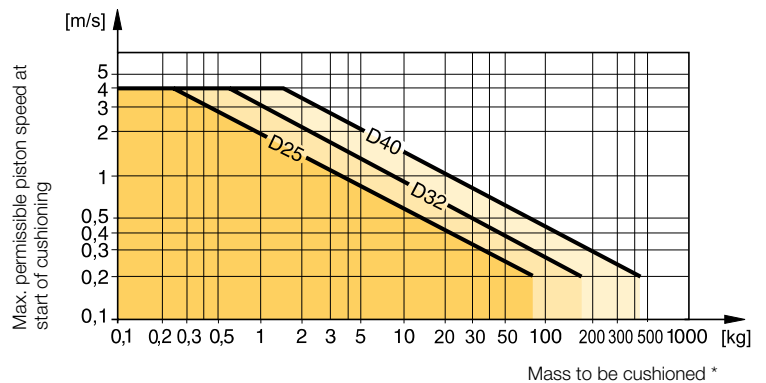

Horizontal application, pressure $p = 6$ bar

* The mass of the carrier has to be taken into account.

If the permitted limit values are exceeded, additional shock absorbers should be fitted in the area of the centre of gravity.

OSP-P Modular Pneumatic Linear Drive Systems

Cylinder Stroke and Dead Length A

- Free choice of stroke length up to 6000 mm in 1 mm steps.
- Longer strokes on request.

Dimensions

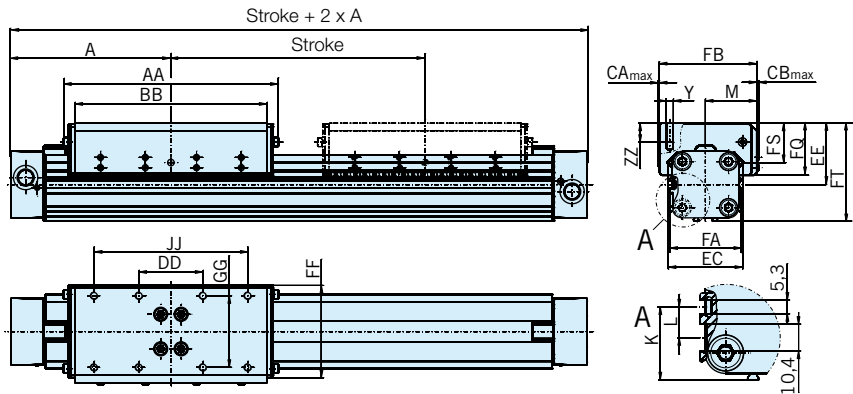

Fig. A shows BG32, BG40 and BG50

Tandem Cylinder

Two pistons are fitted: dimension "Z" is optional. (Please note minimum distance "Zmin").

- Available sizes Ø 25, 32, 40, 50
- Free choice of stroke length up to 6000 mm in 1 mm steps
- Longer strokes on request
- Stroke length to order is stroke + dimension "Z"

Other mountings and options see accessories.

Tandem Cylinder

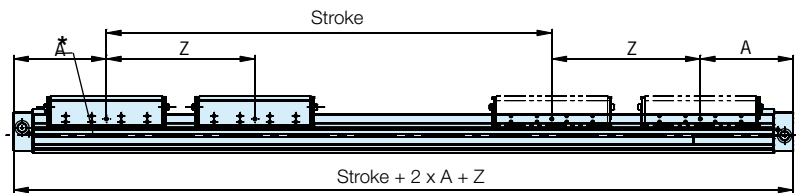

Please note:

To avoid multiple actuation of magnetic switches, the second piston is not equipped with magnets.

Standard air connection

End cap can be rotated 4 x 90°. The air connection and cushion screw can therefore be positioned as desired.

* Piston with magnet

End Cap/Air Connection can be rotated 4 x 90°

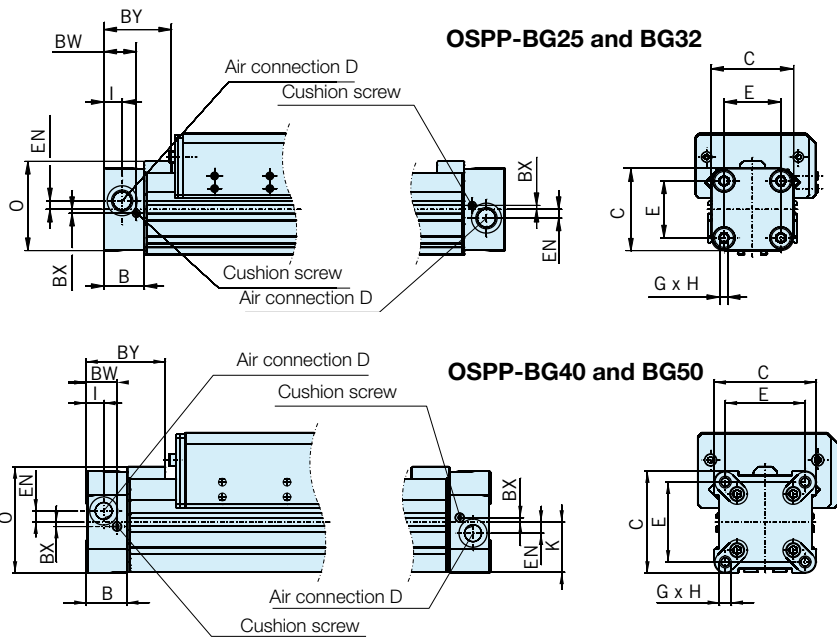

Dimensions [mm]

Series	A	B	C	D	E	G	H	I	K	L	M	O	Y	Z _{min}	AA	BB	BW
BG25	100	22	41	G1/8	27	M5	15	9	17.5	-	32	47	M6	128	126	108	17.5
BG32	125	25.5	52	G1/4	36	M6	15	11.5	28.5	12	40	59	M6	170	168	150	20.5
BG40	150	28	69	G1/4	54	M6	15	12	34.5	12	47	72	M6	212	198	178	21
BG50	175	33	87	G1/4	70	M6	15	14.5	43.5	12	54	86	M6	251	240	220	27
Series	BX	BY	CA _{max}	CB _{max}	DD	EC	EE	EN	FA	FB	FF	FQ	FS	FT	GG	JJ	ZZ
BG25	2.2	40	1.5	1.5	40	44	38	3.6	44	60	56	32	24	59.5	43	80	12
BG32	2.5	44	0	2	50	58	48	5.5	56	76	72	40.8	30.8	76.5	56	120	12
BG40	3	54	0	1	70	67	58	7.5	67	89	84	48	36	92.5	60	140	12
BG50	-	59	0	0	100	77.5	63	11	80	101	94	49	36	106.5	78	200	12



OSP-P Modular Pneumatic Linear Drive Systems

Both Air Connections at One End

A special end cap with both air connections on one side is available for situations where shortage of space, simplicity of installation or the nature of the process make it desirable.

Air supply to the other end is given via internal air passages.

In this case the end caps cannot be rotated.

End cap - Air connection both at one end Series OSPP-BG 25

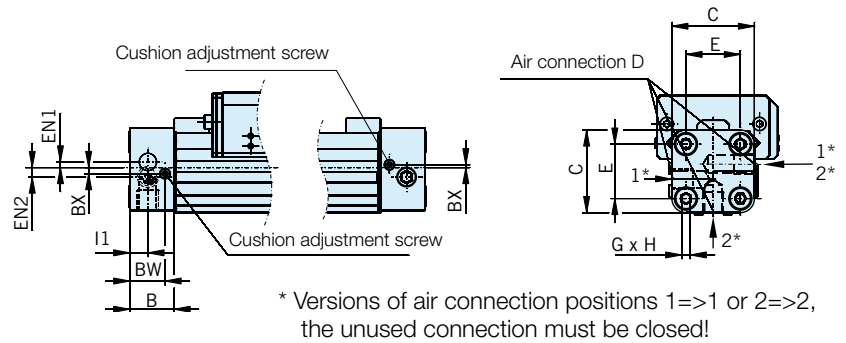

End cap - Air connection both at one end Series OSPP-BG 32 to BG50

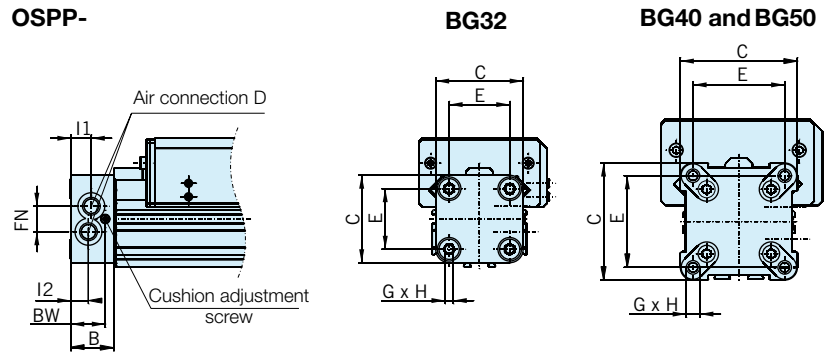

Air Connection on the End-face

In some situations it is necessary or desirable to fit a special end cap with the air connection on the end-face instead of the standard end cap with the air connection on the side.

The special end cap can also be rotated 4 x 90° to locate the cushion adjustment screw as desired.

Supplied in pairs.

End cap - Air connection on the End-face Series OSPP-BG 25 to BG50

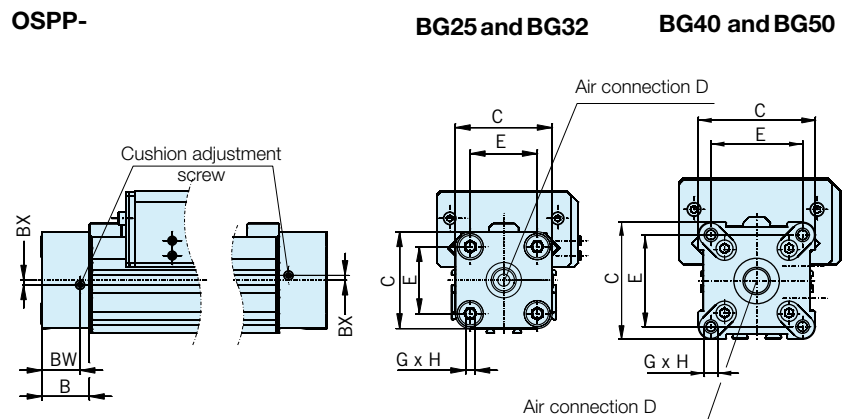

Dimensions [mm]

Series	B	C	D	E	G	H	BW	BX	BY	EN1	EN2	FN	I1	I2
BG25	22	41	G1/8	27	M5	15	17.5	2.2	40	3.6	3.9	-	9	-
BG32	25.5	52	G1/4	36	M6	15	20.5	2.5	44	-	-	15.2	12.2	10.5
BG40	28	69	G1/4	54	M6	15	21	3	54	-	-	17	12	12
BG50	33	87	G1/4	70	M6	15	27	-	59	-	-	22	14.5	14.5

Linear Drive Accessories Ø 25-50 mm

End Cap Mountings

For Linear Drive:

- Series OSPP-BG

On the end-face of each cylinder end cap there are four threaded holes for mounting the cylinder. The hole layout is square, so that the mounting can be fitted to the bottom, top or either side.

The air connection can still be positioned as desired.



Series OSPP-BG25 and BG32: Type A1

(Supplied in pairs)

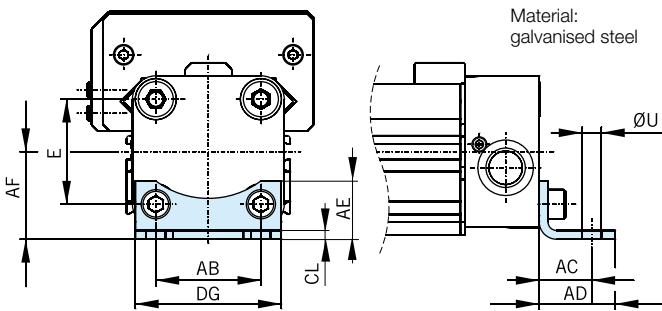

Series OSPP-BG40 and BG50: Type C1

(Supplied in pairs)

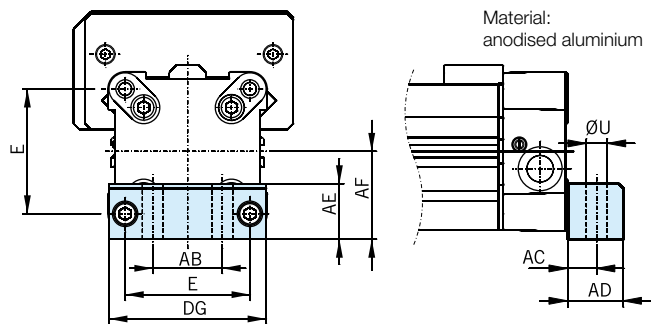

Mid-Section Support

For Linear Drive:

- Series OSPP-BG

For permissible support spacings see diagram page 41. Stainless steel version on request.



Series OSPP-BG25 and BG50: Type E1BG

(Mounting from above / below using a cap screws)

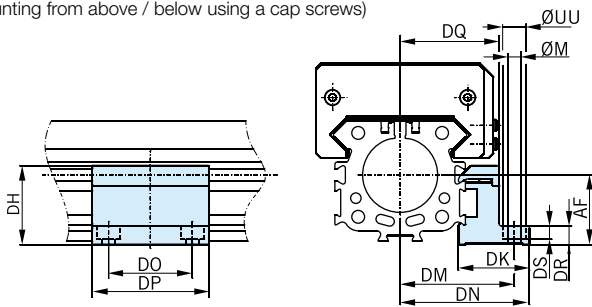

Series OSPP-BG25 and BG50: Type D1BG

(Mounting from below with 2 screws)

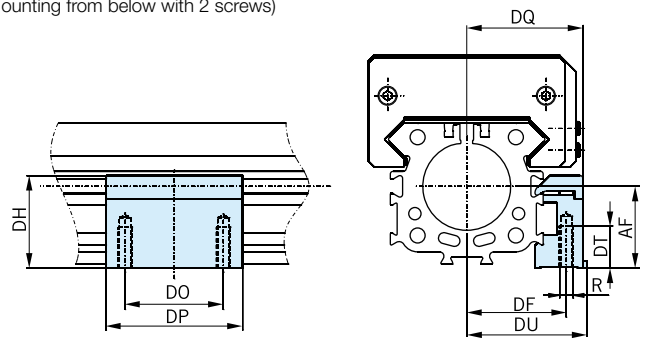

Dimensions [mm]

Series	E	R	ØU	ØM	AB	AC	AD	AE	AF	CL	DF	DG
BG25	27	M5	5.8	5.5	27	16	22	18	22	2.5	29	39
BG32	36	M5	6.6	5.5	36	18	26	20	30	3	36.5	50
BG40	54	M6	9	7	30	12.5	24	24	38	-	39	68
BG50	70	M6	9	7	40	12.5	24	30	48	-	45.5	86

Ident-No.

Series	DH	DK	DM	DN	DO	DP	DQ	DR	DS	DT	DU	ØUU	TypeA1*	TypeC1*	TypeE1BG	TypeD1BG
BG25	20	30.5	42	49.5	36	50	35	8	5.7	15	36.5	10	2010FIL	-	21482FIL	21483FIL
BG32	34	30.5	49	55.5	36	50	42.5	8	5.7	15	42.5	10	3010FIL	-	21487FIL	21488FIL
BG40	43	34	56	63	45	60	48	10	-	11	48	-	-	4010FIL	21510FIL	21511FIL
BG50	56	34	62.5	69.5	45	60	54	23	-	11	54.5	-	-	5010FIL	21594FIL	21593FIL

* = Pair



Order Instructions- BASIC GUIDE

1-6	7+8	9	10	11	12	13	14-18	19	20	21	22	23	24	25
OSPPBG	25	0	0	0	0	0	01100	0	0	0	0	0	0	0

Piston-Ø

25
32
40
50

Stroke

Input in mm (5 digits)

Piston Mounting

0	without
---	---------

Cover / Cable Channel

0	standard
1	cable channel dove tail Ø32, 40, 50
2	cable channel dove tail two-sided Ø32, 40, 50

Version / Piston

0	Standard
1	Tandem
* 6	ATEX Standard ³⁾

Screws

0	standard
1	stainless

Cushioning

0	standard
---	----------

Lubrication

0	standard
1	slow speed ²⁾

End cap position

0	+r0° = in front
1	+r90° = underneath
2	+r180° = at the back
3	+r270° = same side as outerband
4	190° = underneath; r0° = in front
5	180° = at the back; r0° = in front
6	270° = same side as outerband; r0° = in front
7	0° = in front; r90° = underneath
8	180° = at the back; r90° = underneath
9	270° = same side as outerband; r90° = underneath
A	0° = in front; r180° = at the back
B	90° = underneath; r180° = at the back
C	270° = same side as outerband; r180° = at the back
D	0° = in front; r270° = same side as outerband
E	90° = underneath; r270° = same side as outerband
F	180° = at the back; r270° = same side as outerband

Air Connection

0	standard
1	on the end face
2	both at one end (not turnable)
3	left standard right end face
4	right standard left end face
A	3/2 way valve VOE 24 V= Ø25, 32, 40, 50
B	3/2 way valve VOE 230 V~/110V= Ø25, 32, 40, 50
C	3/2 way valve VOE 48 V= Ø25, 32, 40, 50
E	3/2 way valve VOE 110 V~ Ø25, 32, 40, 50

Seals

0	standard (NBR)
1	Viton ^{® 1)}

End cap position (air connection)

Cylinder R (right end side)

Cylinder L (left end side)

¹⁾ Viton with VOE not possible.

²⁾ "Slow speed lubrication" in combination with „Viton[®]“ seals on demand.

³⁾ ATEX with VOE not possible.

Accessories - please order separately

Description	Further information see
End Cap Mounting	Page 93
Mid-Section Support	Page 94
Magnetic Switches	Page 110



OSP

ORIGA
SYSTEM
PLUS

Adaptive modular system

The Origa system plus – OSP – provides a comprehensive range of linear guides for the pneumatic and electric linear drives.

Advantages:

- Takes high loads and forces
- High precision
- Smooth operation
- Can be retrofitted
- Can be installed in any position

Rodless Pneumatic Cylinder Series OSP - P

Piston diameters 10 – 80 mm

See page 16 (Standard)

See page 35 (ATEX-Version)



BASIC GUIDE

Compact, robust plain bearing guide for medium loads.

Piston diameters 25 – 50 mm

See page 39 (Standard)

See page 35 (ATEX-Version)

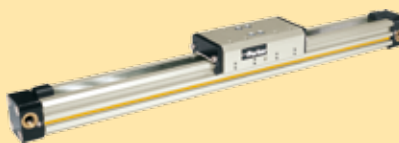

Linear Guides

SLIDELINE

The cost-effective plain bearing guide for medium loads. Active/ Passive Brake optional.

Piston diameters 16 – 80 mm

See page 47 (Standard)

See page 35 (ATEX-Version)



POWERSLIDE

The roller guide for heavy loads and hard application conditions

Piston diameters 16 – 50 mm

See page 50



PROLINE

The compact aluminium roller guide for high loads and velocities.

Active/ Passive Brake optional.

Piston diameters 16 – 50 mm

See page 55



STARLINE

Recirculating ball bearing guide for very high loads and precision

Piston diameters 16 – 50 mm

See page 58



KF GUIDE

Recirculating ball bearing guide.

Correspond to FESTO dimensions (Type DGPL-KF)

Piston diameters 16 – 50 mm

See page 65



HD HEAVY DUTY GUIDE

Recirculating ball bearing guide for highest loads and greatest accuracy.

Piston diameters 25 – 50 mm

See page 72



**Plain Bearing Guide
SLIDELINE**

Series SL 16 to 80 for Linear Drive

Features:

- ATEX-version (without brake) is also available
See page 35
- Anodised aluminium guide rail with prism-shaped slideway arrangement
- Adjustable plastic slide elements – optional with integral brake
- Composite sealing system with plastic and felt wiper elements to remove dirt and lubricate the slideways
- Corrosion resistant version available on request
- Any length of stroke up to 5500 mm (longer strokes on request)



**Integrated Brake (optional)
for series OSP-P25 to OSP-P50:**

- Actuated by pressure
- Released by exhausting and spring return

Loads, Forces and Moments

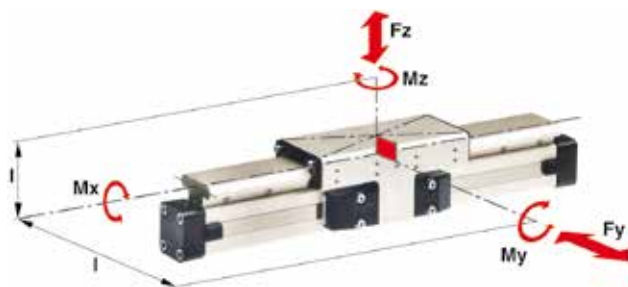

Carriage Without Brake

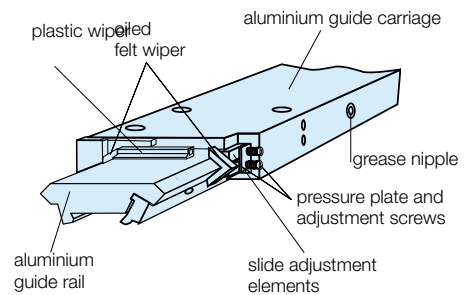

Technical Data

The table shows the maximum permissible values for smooth operation, which should not be exceeded even under dynamic conditions.

The load and moment figures apply to speeds $v < 0.2$ m/s.

*** Please note:**

In the cushioning diagram, add the mass of the guide carriage to the mass to be cushioned.

- 1) Only with integrated brake: Braking force on dry oil-free surface. Values are decreased for lubricated slideways
- 2) Corrosion resistant fixtures available on request

Option - Integrated Brake

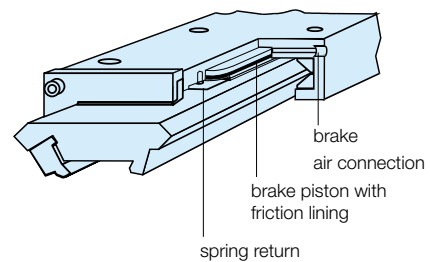

Series	For linear drive	Max. moments [Nm]			Max. loads [N]	Maximum braking force at 6 bar [N] ¹⁾	Mass of linear drive with guide [kg]		Mass* of guide carriage [kg]	Order-No. ** SLIDELINE ²⁾ Guide without cylinder	
		Mx	My	Mz			Fy, Fz	with 0 mm stroke		increase per 100 mm stroke	without brake
SL16	OSP-P16	6	11	11	325	-	0.57	0.22	0.23	20341	-
SL25	OSP-P25	14	34	34	675	325	1.55	0.39	0.61	20342	20409
SL32	OSP-P32	29	60	60	925	545	2.98	0.65	0.95	20196	20410
SL40	OSP-P40	50	110	110	1600	835	4.05	0.78	1.22	20343	20411
SL50	OSP-P50	77	180	180	2000	1200	6.72	0.97	2.06	20195	20412
SL63	OSP-P63	120	260	260	2500	-	11.66	1.47	3.32	20853	-
SL80	OSP-P80	120	260	260	2500	-	15.71	1.81	3.32	21000	-

** Please use this order pattern: Order-No. + „stroke in mm“ (5 digits)
Example: SLIDELINE guide without brake D25 mm, stroke 1000 mm: 20342-01000



Dimensions

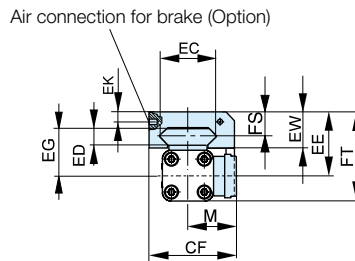
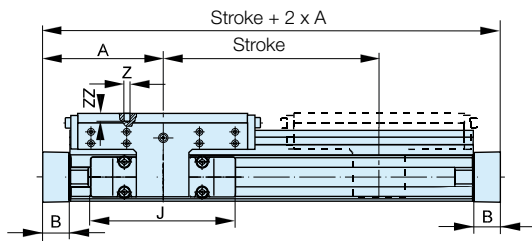

For further mounting elements and options see accessories.

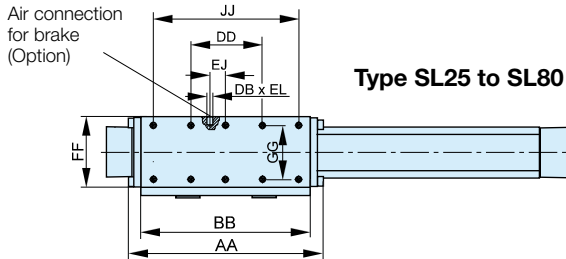

Type SL25 to SL80

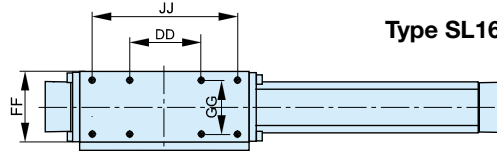

Type SL16

Dimensions [mm]

Series	A	B	J	M	Z	AA	BB	DB	DD	CF	EC	ED	EE	EG	EJ	EK	EL	EW	FF	FT	FS	GG	JJ	ZZ
SL16	65	14	69	31	M4	106	88	-	30	55	36	8	40	30	-	-	-	22	48	55	14	36	70	8
SL25	100	22	117	40.5	M6	162	142	M5	60	72.5	47	12	53	39	22	6	6	30	64	73.5	20	50	120	12
SL32	125	25.5	152	49	M6	205	185	M5	80	91	67	14	62	48	32	6	6	33	84	88	21	64	160	12
SL40	150	28	152	55	M6	240	220	M5	100	102	77	14	64	50	58	6	6	34	94	98.5	21.5	78	200	12
SL50	175	33	200	62	M6	284	264	M5	120	117	94	14	75	56	81	6	6	39	110	118.5	26	90	240	16
SL63	215	38	256	79	M8	312	292	-	130	152	116	18	86	66	-	-	-	46	152	139	29	120	260	14
SL80	260	47	348	96	M8	312	292	-	130	169	116	18	99	79	-	-	-	46	152	165	29	120	260	14

Mid-Section Support

Mid-section supports are required from a certain stroke length to prevent excessive deflection and vibration of the linear drive. The diagrams show the maximum permissible unsupported length in relation to loading.

A distinction must be drawn between loading 1 and loading 2. Deflection of 0.5 mm max. between supports is permissible.

Note:

For speeds $v > 0.5$ m/s the distance between supports should not exceed 1 m.

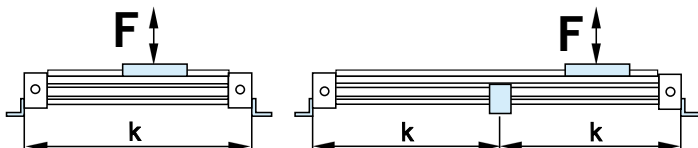
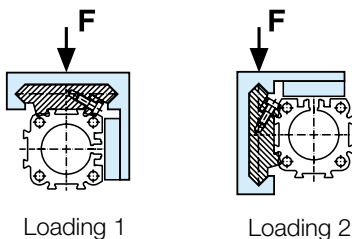

Permissible unsupported length: SL 16, SL 25, SL 32

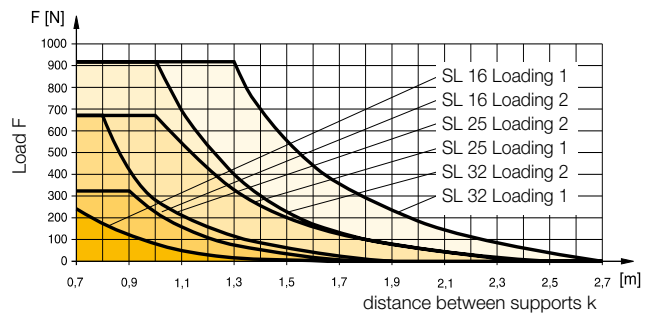

Permissible unsupported length: SL40, SL50, SL63, SL80

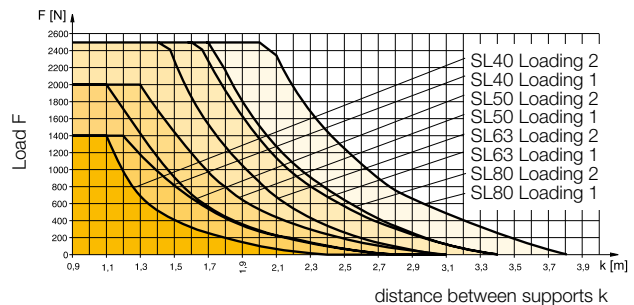

Order Instructions- SLIDELINE

1-4	5+6	7	8	9	10	11	12-16	17	18	19	20	21	22	23	24	25
OSPP	25	0	0	0	0	0	01100	0	0	0	0	0	0	0	0	0

Piston-Ø

16
25
32
40
50
63
80

Stroke

Input in mm
(5 digits)

Piston Mounting

0	without
---	---------

Measuring system

0	without
X	SFI 0.1 mm
Y	SFI 1 mm

Screws

0	standard
1	stainless

Cushioning

0	standard
---	----------

Version / Piston

0	standard
1	Tandem

Lubrication

0	standard
1	slow speed ²⁾

End cap position

0	l+r 0° = in front
1	l+r 90° = underneath
2	l+r 180° = at the back
3	l+r 270° = same side as outerband
4	l 90° = underneath; r 0° = in front
5	l 180° = at the back; r 0° = in front
6	l 270° = same side as outerband; r 0° = in front
7	l 0° = in front; r 90° = underneath
8	l 180° = at the back; r 90° = underneath
9	l 270° = same side as outerband; r 90° = underneath
A	l 0° = in front; r 180° = at the back
B	l 90° = underneath; r 180° = at the back
C	l 270° = same side as outerband; r 180° = at the back
D	l 0° = in front; r 270° = same side as outerband
E	l 90° = underneath; r 270° = same side as outerband
F	l 180° = at the back; r 270° = same side as outerband

Guides/ Brakes/ Inversion

0	without
2	Slideline SL Ø 16-80
3	Slideline with Activebrake SL-AB Ø 25-50
4	Slideline with Multibrake SL-MB Ø 25-80

Cover / Cable Channel

0	standard
1	cable channel
2	cable channel two-sided
X	without Coverrail

Air Connection

0	standard
1	on the end face
2	both at one end (not turnable)
3	left standard right end face
4	right standard left end face
A	3/2 way valve VOE 24 V = Ø 25,32,40,50
B	3/2 way valve VOE 230 V~/110 V= Ø 25,32,40,50
C	3/2 way valve VOE 48 V = Ø 25,32,40,50
E	3/2 way valve VOE 110 V~ Ø 25,32,40,50

Seals

0	standard (NBR)
1	Viton ^{® 1)}

add. Guide Carriage

0	without
2	Guide Carriage Slideline SL Ø 16-80
3	Guide Carriage Slideline Activebrake SL-AB Ø 26-50
4	Guide Carriage Slideline Multibrake SL-MB Ø 25-80
M	Guide Carriage Slideline Multibrake SL-MB without brakefunction Ø 25-80

End cap position (air connection)

¹⁾ Viton with VOE not possible.

²⁾ "Slow speed lubrication" in combination with „Viton®“ seals on demand.

**Roller Guide
POWERSLIDE**

Series PS 16 to 50 for Linear Drive



Features:

- Anodised aluminium guide carriage with vee rollers having 2 rows of ball bearings
- Hardened steel guide rail
- Several guide sizes can be used on the same drive
- Corrosion resistance version available on request
- Max. speed $v = 3 \text{ m/s}$,
- Tough roller cover with wiper and grease nipple
- Any length of stroke up to 3500 mm, (longer strokes on request)

Loads, Forces and Moments

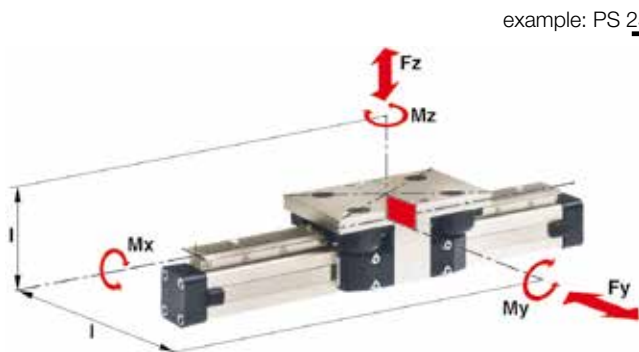

example: PS 25/35

width of guide rail (35 mm)
size of drive OSP-P25

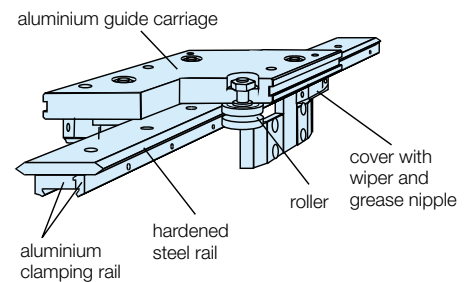

Technical Data

The table shows the maximum per-missible values for smooth operation, which should not be exceeded even under dynamic conditions.

*** Please note:**

In the cushioning diagram, add the mass of the guide carriage to the mass to be cushioned.

Series	For linear drive	Max. Moment [Nm]			Max. loads [N]	Mass of linear drive with guide [kg]		Mass* guide carriage [kg]	Order-No** POWERSLIDE Guide without cylinder ¹⁾
		Mx	My	Mz		Fy, Fz	with 0 mm stroke		
PS 16/25	OSP-P16	14	45	45	1400	0.93	0.24	0.7	20285
PS 25/25	OSP-P25	14	63	63	1400	1.5	0.4	0.7	20015
PS 25/35	OSP-P25	20	70	70	1400	1.7	0.4	0.8	20016
PS 25/44	OSP-P25	65	175	175	3000	2.6	0.5	1.5	20017
PS 32/35	OSP-P32	20	70	70	1400	2.6	0.6	0.8	20286
PS 32/44	OSP-P32	65	175	175	3000	3.4	0.7	1.5	20287
PS 40/44	OSP-P40	65	175	175	3000	4.6	1.1	1.5	20033
PS 40/60	OSP-P40	90	250	250	3000	6	1.3	2.2	20034
PS 50/60	OSP-P50	90	250	250	3000	7.6	1.4	2.3	20288
PS 50/76	OSP-P50	140	350	350	4000	11.5	1.8	4.9	20289

¹⁾ corrosion resistance version available on request (max. loads and moments are 25% lower)

** Please use this order pattern: Order-No. + „stroke in mm“ (5 digits)
Example: PS25/25 Guide D25 mm, stroke 1000 mm: 20015-01000



Dimensions

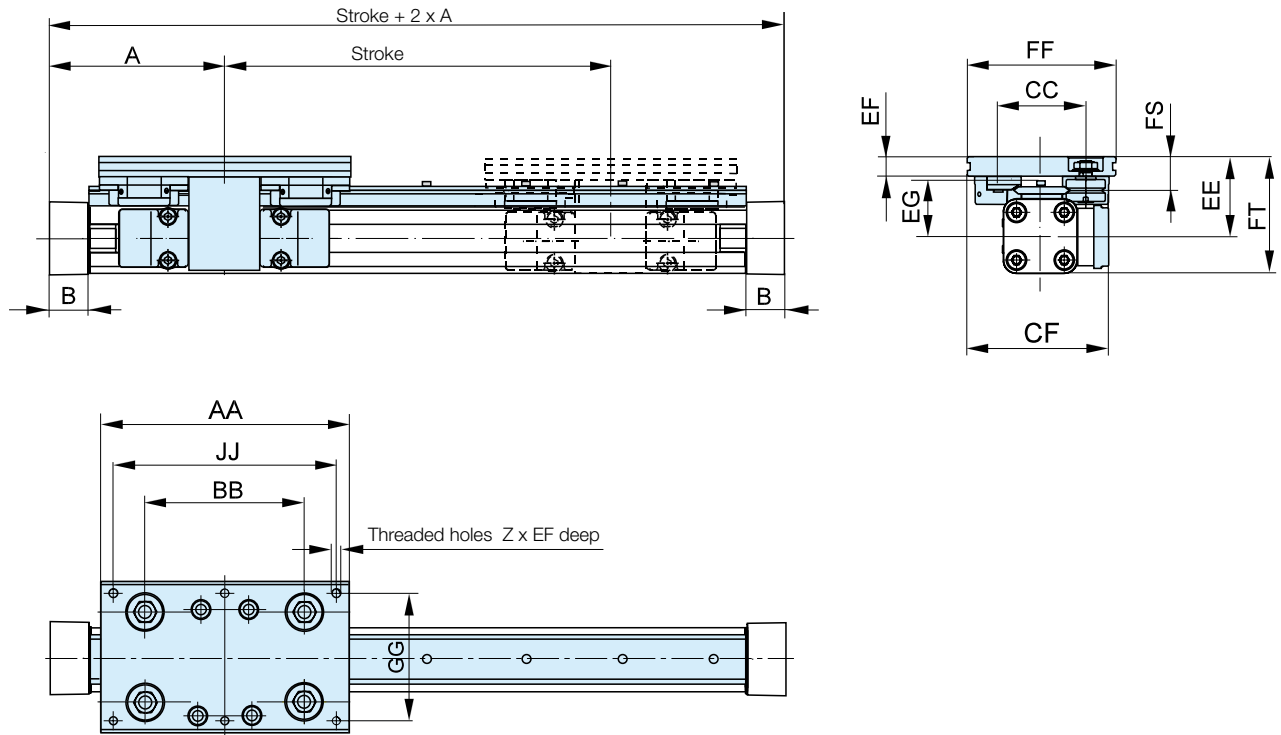

Dimensions [mm]

Series	A	B	Z	AA	BB	CC	CF	EE	EF	EG	FF	FS	FT	GG	JJ
PS 16/25	65	14	4xM6	120	65	47	80	49	12	35	80	21	64	64	100
PS 25/25	100	22	6xM6	145	90	47	79.5	53	11	39	80	20	73.5	64	125
PS 25/35	100	22	6xM6	156	100	57	89.5	52.5	12.5	37.5	95	21.5	73	80	140
PS 25/44	100	22	6xM8	190	118	73	100	58	15	39	116	26	78.5	96	164
PS 32/35	125	25.5	6xM6	156	100	57	95.5	58.5	12.5	43.5	95	21.5	84.5	80	140
PS 32/44	125	25.5	6xM8	190	118	73	107	64	15	45	116	26	90	96	164
PS 40/44	150	28	6xM8	190	118	73	112.5	75	15	56	116	26	109.5	96	164
PS 40/60	150	28	6xM8	240	167	89	122.5	74	17	54	135	28.5	108.5	115	216
PS 50/60	175	33	6xM8	240	167	89	130.5	81	17	61	135	28.5	123.5	115	216
PS 50/76	175	33	6xM10	280	178	119	155.5	93	20	64	185	39	135.5	160	250

Mid-Section Support

Mid section supports are required from a certain stroke length to prevent excessive deflection and vibration of the linear drive. The diagrams show the maximum permissible unsupported length in relation to loading. A distinction must be drawn between loading 1 and loading 2. Deflection of 0.5 mm max. between supports is permissible.

Note

For speeds $v > 0.5$ m/s the distance between supports should not exceed 1m.

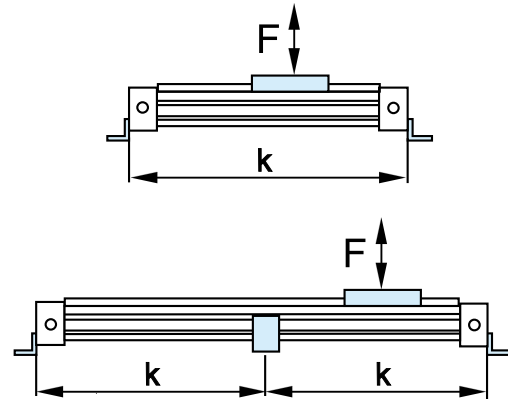
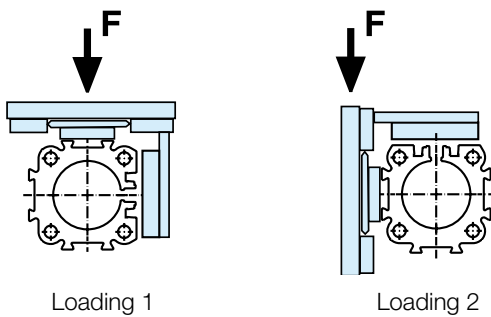

Permissible unsupported length: PS 16/25, PS 25/25, PS 25/35, PS 25/44

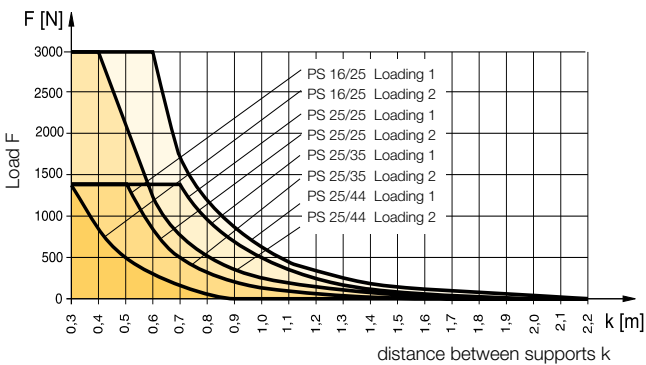

Permissible unsupported length: PS 32/35, PS 32/44

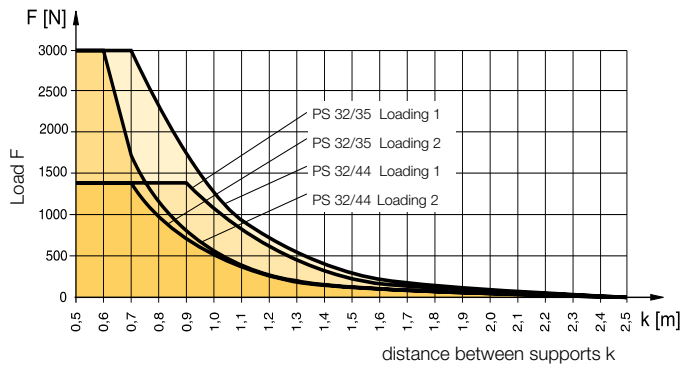

Permissible unsupported length: PS 40/44, PS 40/60

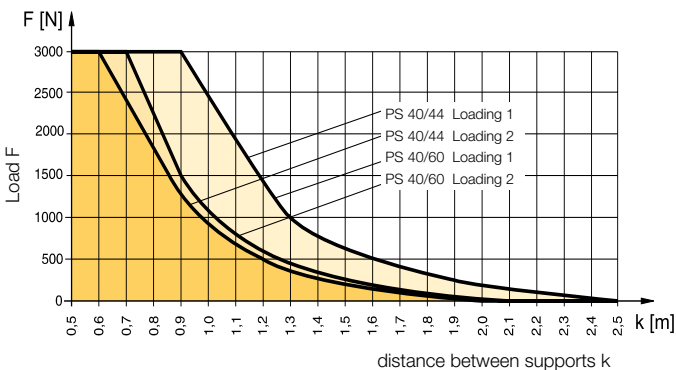

Permissible unsupported length: PS 50/60, PS 50/76

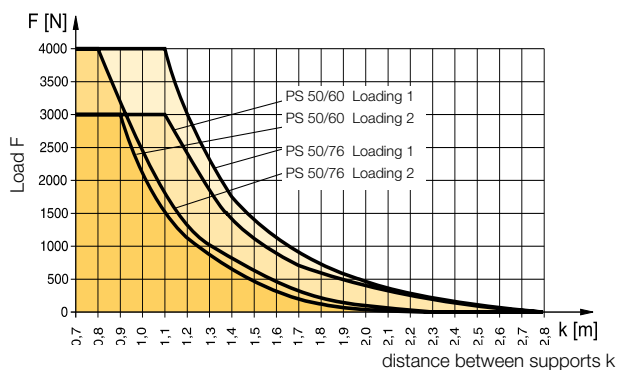

Service Life

- Determination of load factor LF from the loads to be carried
- Calculation of service life in km

Lubrication

For maximum system life, lubrication of the rollers must be maintained at all times.

Only high quality Lithium based greases should be used.

Lubrication intervals are dependant on environmental conditions (temperature, running speed, grease quality etc.) therefore the installation should be regularly inspected.

1. Calculation of load factor L_F

$$L_F = \frac{M_x}{M_{x_{max}}} + \frac{M_y}{M_{y_{max}}} + \frac{M_z}{M_{z_{max}}} + \frac{F_y}{F_{y_{max}}} + \frac{F_z}{F_{z_{max}}}$$

with combined loads, L_F should not exceed the value 1.

2. Service Life Calculation

- For PS 16/25, PS 25/25, PS 25/35, and PS 32/35: $\text{Service life [km]} = \frac{106}{(L_F + 0,02)^3}$
- For PS 25/44, PS 32/44, PS 40/44, PS 40/60 and PS 50/60: $\text{Service life [km]} = \frac{314}{(L_F + 0,015)^3}$
- For PS 50/76: $\text{Service life [km]} = \frac{680}{(L_F + 0,015)^3}$

Order Instructions- POWERSLIDE

1-4	5+6	7	8	9	10	11	12-16	17	18	19	20	21	22	23	24	25
OSPP	25	0	0	0	0	0	01100	0	0	0	0	0	0	0	0	0

Piston-Ø

16
25
32
40
50

Stroke

Input in mm
(5 digits)

Piston Mounting

0	without
---	---------

Measuring system

0	without
X	SFI 0.1 mm
Y	SFI 1 mm

Screws

0	standard
1	stainless

Cushioning

0	standard
1	max. length ³⁾

Version / Piston

0	standard
1	Tandem

Lubrication

0	standard
1	Slow speed ²⁾³⁾

End cap position

0	l+r 0° = in front
1	l+r 90° = underneath
2	l+r 180° = at the back
3	l+r 270° = same side as outerband
4	l 90° = underneath; r 0° = in front
5	l 180° = at the back; r 0° = in front
6	l 270° = same side as outerband; r 0° = in front
7	l 0° = in front; r 90° = underneath
8	l 180° = at the back; r 90° = underneath
9	l 270° = same side as outerband; r 90° = underneath
A	l 0° = in front; r 180° = at the back
B	l 90° = underneath; r 180° = at the back
C	l 270° = same side as outerband; r 180° = at the back
D	l 0° = in front; r 270° = same side as outerband
E	l 90° = underneath; r 270° = same side as outerband
F	l 180° = at the back; r 270° = same side as outerband

Guides/ Brakes/ Inversion

0	without
E	PSXX/25 Powerslide Ø 16, 25
F	PSXX/35 Powerslide Ø 25, 32
G	PSXX/44 Powerslide Ø 25, 32, 40
H	PSXX/60 Powerslide Ø 40, 50
I	PSXX/76 Powerslide Ø 50

Cover / Cable Channel

0	standard
1	cable channel
2	cable channel two-sided
X	without Cover rail

add. Guide Carriage

0	without
E	Guide Carriage Powerslide PSXX/25 Ø 16, 25
F	Guide Carriage Powerslide PSXX/35 Ø 25, 32
G	Guide Carriage Powerslide PSXX/44 Ø 25, 32, 40
H	Guide Carriage Powerslide PSXX/60 Ø 40, 50
I	Guide Carriage Powerslide PSXX/76 Ø 50

Air Connection

0	standard
1	on the end face
2	both at one end (not turnable)
3	left standard right end face
4	right standard left end face
A	3/2 way valve VOE 24 V= Ø 25,32,40,50
B	3/2 way valve VOE 230 V~/110 V= Ø 25,32,40,50
C	3/2 way valve VOE 48 V= Ø 25,32,40,50
E	3/2 way valve VOE 110 V~/ Ø 25,32,40,50

Seals

0	standard (NBR)
1	Viton® ¹⁾

End cap position
(air connection)

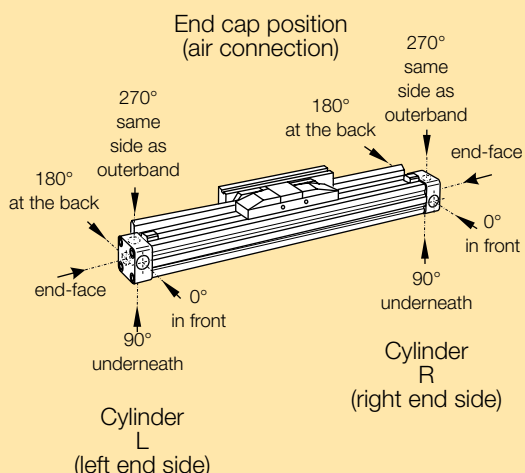

¹⁾ Viton with VOE not possible.

²⁾ "Slow speed lubrication" in combination with „Viton®“ seals on demand.

³⁾ „Lubrication slow speed“ in combination with „max. cushioning length“ not possible.

OSP-P Modular Pneumatic Linear Drive Systems

Aluminium Roller Guide PROLINE

Series PL 16 to 50 for Linear Drive

Features:

- High precision
- High velocities (10 m/s)
- Smooth operation - low noise
- Integrated wiper system
- Long life lubrication
- Compact dimensions - compatible to Slideline plain bearing guide
- Any length of stroke up to 3750 mm

Loads, Forces and Moments

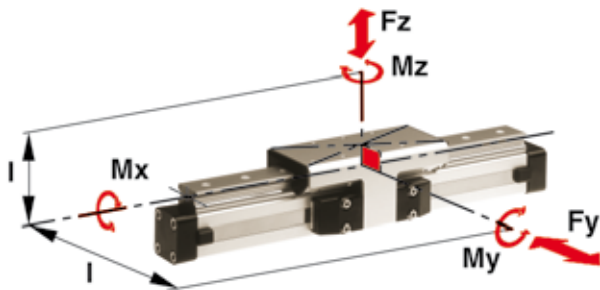

Technical Data

The table shows the maximal permissible loads. If multiple moments and forces act upon the cylinder simultaneously, the following equation applies:

$$\frac{M_x}{M_{x_{max}}} + \frac{M_y}{M_{y_{max}}} + \frac{M_z}{M_{z_{max}}} + \frac{F_y}{F_{y_{max}}} + \frac{F_z}{F_{z_{max}}} \leq 1$$

The sum of the loads should not exceed >1. With a load factor of less than 1, service life is 8000 km

The table shows the maximum permissible values for light, shock-free operation, which must not be exceeded even under dynamic conditions.

*** Please note:**

The mass of the carriage has to be added to the total moving mass when using the cushioning diagram



Integrated Brake (optional) for series OSP-P25 to OSP-P50:

- Actuated by pressurisation
- Released by depressurisation and spring actuation

Carriage Without Brake

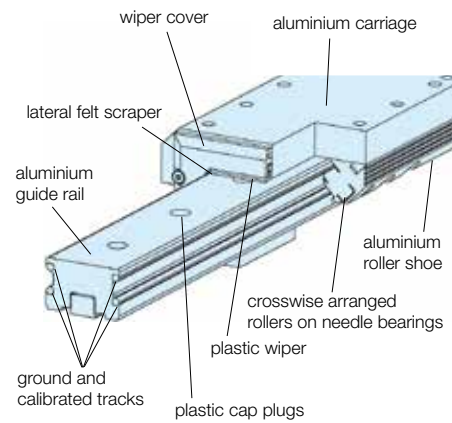

Option - Integrated Brake

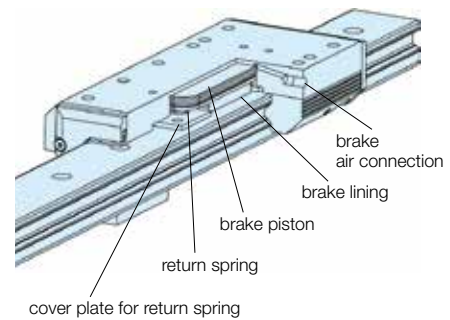

Series	For linear drive	Max. Moment [Nm]			Max. loads [N]	Maximum braking force at 6 bar [N] ¹⁾	Mass of linear drive with guide [kg]		Mass* guide carriage [kg]	Order-No** PROLINE Guide without cylinder	
		Mx	My	Mz			Fy, Fz	with 0mm stroke		increase per 100mm stroke	without Brake
PL 16	OSP-P16	8	12	12	542	-	0.55	0.19	0.24	20855	-
PL 25	OSP-P25	16	39	39	857	on request	1.65	0.40	0.75	20856	20860
PL 32	OSP-P32	29	73	73	1171	on request	3.24	0.62	1.18	20857	20861
PL 40	OSP-P40	57	158	158	2074	on request	4.35	0.70	1.70	20858	20862
PL 50	OSP-P50	111	249	249	3111	on request	7.03	0.95	2.50	20859	20863

** Please use this order pattern: Order-No. + „stroke in mm“ (5 digits)
Example: PROLINE guide without brake D16mm, stroke 1000mm: 20855-01000



Dimensions - Series OSP-P PL16, PL25, PL32, PL40, PL50

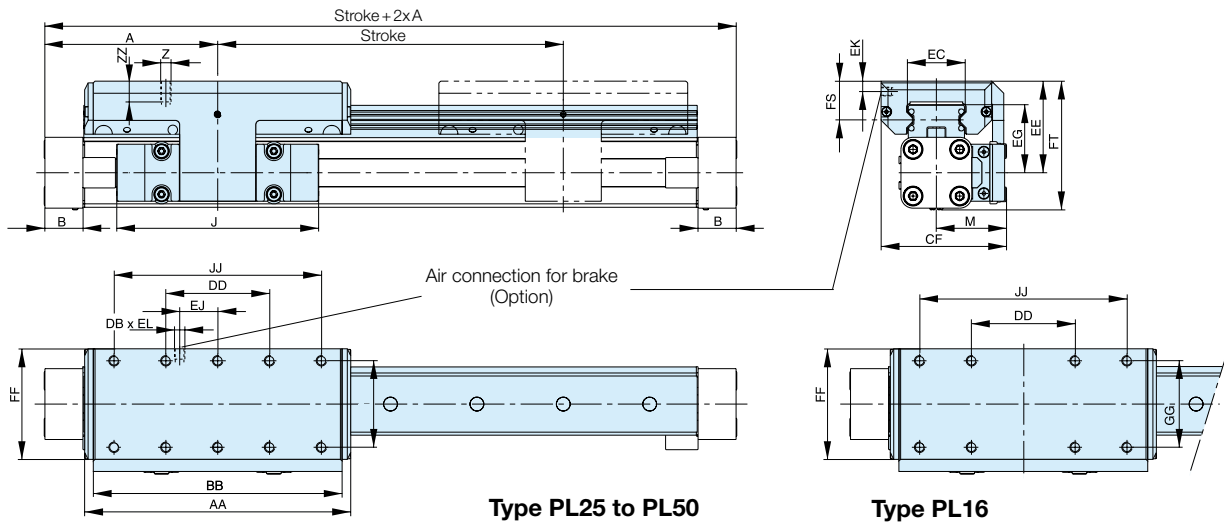

Dimensions [mm] Series OSP-P PL16, PL25, PL32, PL40, PL50

Series	A	B	J	M	Z	AA	BB	DB	DD	CF	EC	EE	EG	EJ	EK	EL	FF	FS	FT	GG	JJ	ZZ
PL16	65	14	69	31	M4	98	88	-	30	55	23	40	30	-	-	-	48	17	55	36	70	8
PL25	100	22	117	40.5	M6	154	144	M5	60	72.5	32.5	53	39	22	6	6	64	23	73.5	50	120	12
PL32	125	25.5	152	49	M6	197	187	M5	80	91	42	62	48	32	6	6	84	25	88	64	160	12
PL40	150	28	152	55	M6	232	222	M5	100	102	47	64	50.5	58	6	6	94	23.5	98.5	78	200	12
PL50	175	33	200	62	M6	276	266	M5	120	117	63	75	57	81	6	6	110	29	118.5	90	240	16

Mid-Section Support

Mid-section supports are required from a certain stroke length to prevent excessive deflection and vibration of the linear drive. The diagrams show the maximum permissible unsupported length in relation to loading. A distinction must be drawn between loading 1 and loading 2. Deflection of 0.5 mm max. between supports is permissible.

Note:

For speeds $v > 0.5$ m/s the distance between supports should not exceed 1 m.

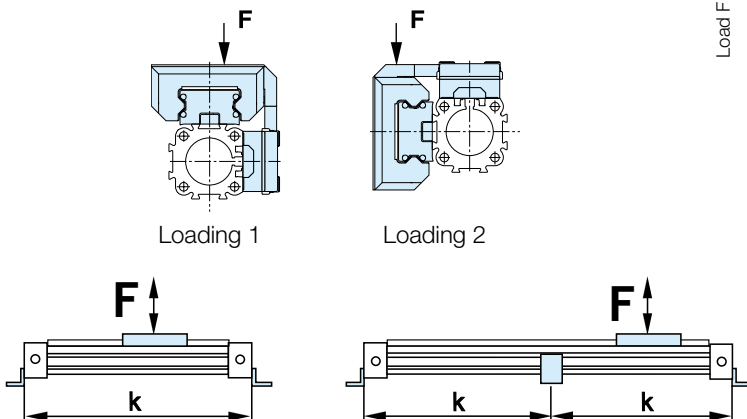

Permissible Unsupported Length PL16, PL25, PL32, PL40 and PL50

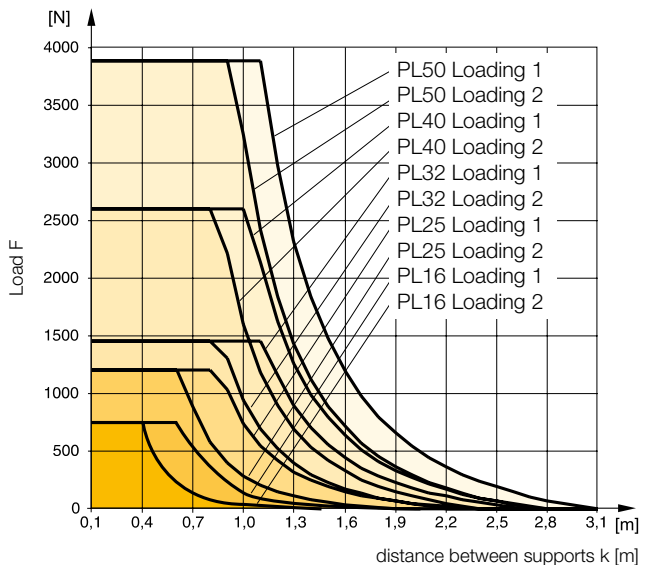

Order Instructions- PROLINE

1-4	5+6	7	8	9	10	11	12-16	17	18	19	20	21	22	23	24	25
OSPP	25	0	0	0	0	0	01100	0	0	0	0	0	0	0	0	0

Piston-Ø

16
25
32
40
50

Stroke

Input in mm
(5 digits)

Piston Mounting

0	without
---	---------

Measuring system

0	without
X	SFI 0.1 mm
Y	SFI 1 mm

Screws

0	standard
---	----------

Cushioning

0	standard
1	max. length ³⁾

Version / Piston

0	standard
1	Tandem

Lubrication

0	standard
1	Slow speed ²⁾³⁾

End cap position

0	l+r 0° = in front
1	l+r 90° = underneath
2	l+r 180° = at the back
3	l+r 270° = same side as outerband
4	l 90° = underneath; r 0° = in front
5	l 180° = at the back; r 0° = in front
6	l 270° = same side as outerband; r 0° = in front
7	l 0° = in front; r 90° = underneath
8	l 180° = at the back; r 90° = underneath
9	l 270° = same side as outerband; r 90° = underneath
A	l 0° = in front; r 180° = at the back
B	l 90° = underneath; r 180° = at the back
C	l 270° = same side as outerband; r 180° = at the back
D	l 0° = in front; r 270° = same side as outerband
E	l 90° = underneath; r 270° = same side as outerband
F	l 180° = at the back; r 270° = same side as outerband

Guides/ Brakes/ Inversion

0	without
6	Proline PL Ø 16-50
7	Proline with Activebrake PL-AB Ø 25-50
8	Proline with Multibrake PL-MB Ø 25-50

Cover / Cable Channel

0	standard
1	cable channel
2	cable channel two-sided
X	without Cover rail

Air Connection

0	standard
1	on the end face
2	both at one end (not turnable)
3	left standard right end face
4	right standard left end face
A	3/2 way valve VOE 24 V = Ø 25, 32, 40, 50
B	3/2 way valve VOE 230 V~ / 110 V = Ø 25, 32, 40, 50
C	3/2 way valve VOE 48 V = Ø 25, 32, 40, 50
E	3/2 way valve VOE 110 V~ Ø 25, 32, 40, 50

Seals

0	standard (NBR)
1	Viton ^{® 1)}

add. Guide Carriage

0	without
6	Guide Carriage Proline PL Ø 16-50
7	Guide Carriage Proline Activebrake PL-AB Ø 25-50
8	Guide Carriage Proline Multibrake PL-MB Ø 25-50
N	Guide Carriage Proline Multibrake PL-MB without brake function Ø 25-50

End cap position (air connection)

270° same side as outerband

180° at the back

end-face

0° in front

90° underneath

end-face

0° in front

90° underneath

Cylinder R (right end side)

Cylinder L (left end side)

¹⁾ Viton with VOE not possible.

²⁾ "Slow speed lubrication" in combination with „Viton[®]“ seals on demand.

³⁾ „Lubrication slow speed“ in combination with „max. cushioning length“ not possible.

**Recirculating Ball Bearing Guide
STARLINE
Series STL 16 to 50 for Linear Drive**



Features:

- Polished and hardened steel guide rail
- For very high loads in all directions
- High precision
- Integrated wiper system
- Integrated grease nipples
- Any length of stroke up to 3700 mm
- Anodized aluminium guide carriage – dimensions compatible with OSP guides SLIDELINE and PROLINE
- Installation height (STL16 - 32) compatible with OSP guides SLIDELINE and PROLINE



- Maximum speed
STL16: v = 3 m/s
STL25 to 50: v = 5 m/s

Loads, Forces and Moments

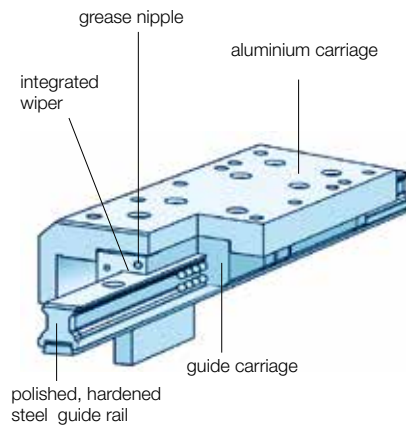
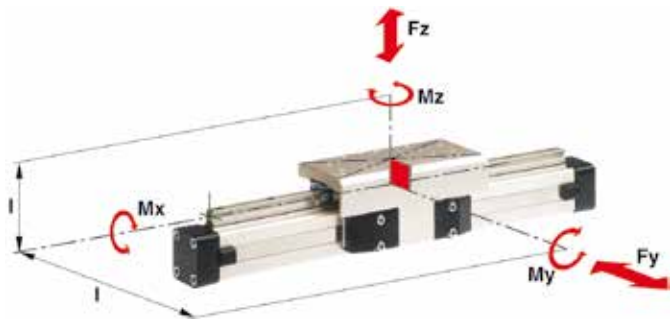

Technical Data

The table shows the maximal permissible loads. If multiple moments and forces act upon the cylinder simultaneously, the following equation applies:

$$\frac{M_x}{M_{x_{max}}} + \frac{M_y}{M_{y_{max}}} + \frac{M_z}{M_{z_{max}}} + \frac{F_y}{F_{y_{max}}} + \frac{F_z}{F_{z_{max}}} \leq 1$$

The sum of the loads should not exceed >1.

The table shows the maximum permissible values for light, shock-free operation, which must not be exceeded even under dynamic conditions.

*** Please note:**

The mass of the carriage has to be added to the total moving mass when using the cushioning diagram

Series	For linear drive	Max. Moment [Nm]			Max. loads [N]		Mass of linear drive with guide [kg]		Mass * guide carriage [kg]	Order-No ** STARLINE Guide without cylinder
		Mx	My	Mz	Fy	Fz	with 0mm stroke	increase per 100 mm stroke		
STL 16	OSP-P16	15	30	30	1000	1000	0.598	0.210	0.268	21111
STL 25	OSP-P25	50	110	110	3100	3100	1.733	0.369	0.835	21112
STL 32	OSP-P32	62	160	160	3100	3100	2.934	0.526	1.181	21113
STL 40	OSP-P40	150	400	400	4000	7500	4.452	0.701	1.901	21114
STL 50	OSP-P50	210	580	580	4000	7500	7.361	0.936	2.880	21115

** Please use this order pattern: Order-No. + „stroke in mm“ (5 digits)
Example: STARLINE guide D16 mm, stroke 1000 mm: 21111-01000



Dimensions - Series OSP-P STL16 to STL 50

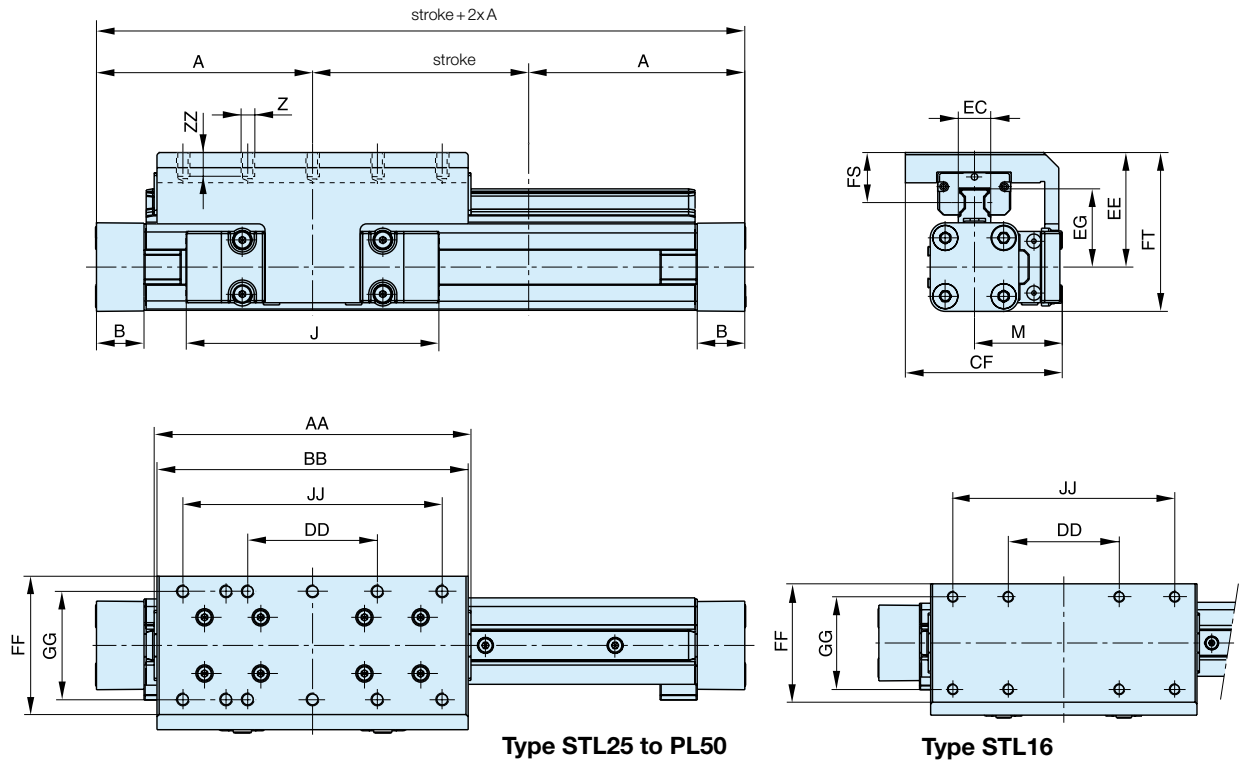

Dimensions [mm] Series OSP-P STL16 to STL50

Series	A	B	J	M	Z	AA	BB	CF	DD	EC	EE	EG	FF	FS	FT	GG	JJ	ZZ
STL16	65	14	69	31	M4	93	90	55	30	15	40	24.6	48	18	55	36	70	8
STL25	100	22	117	40.5	M6	146.6	144	72.5	60	15	53	36.2	64	23.2	73.5	50	120	12
STL32	125	25.5	152	49	M6	186.6	184	91	80	15	62	42.2	84	26.2	88	64	160	12
STL40	150	28	152	55	M6	231	226	102	100	20	72	51.6	94	28.5	106.5	78	200	12
STL50	175	33	200	62	M6	270.9	266	117	120	23	85	62.3	110	32.5	128.5	90	240	16

Mid-Section Support

Mid-section supports are required from a certain stroke length to prevent excessive deflection and vibration of the linear drive. The diagrams show the maximum permissible unsupported length in relation to loading. A distinction must be drawn between loading 1 and loading 2. Deflection of 0.5 mm max. between supports is permissible.

Note

For speeds $v > 0.5$ m/s the distance between supports should not exceed 1m.

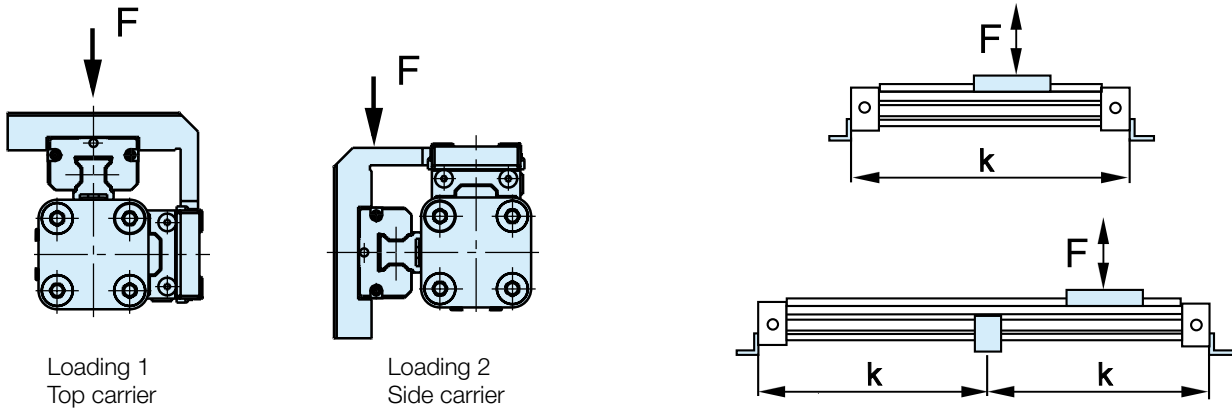

Permissible Unsupported Length STL16 to STL50

Loading 1 - Top carrier

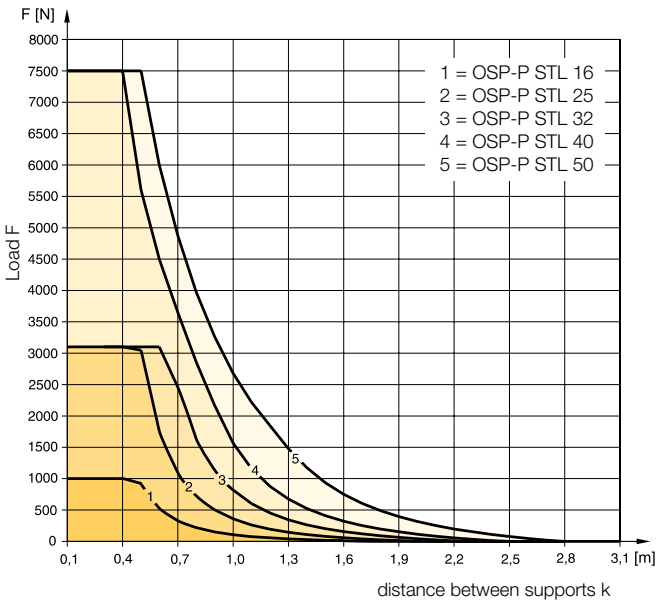

Permissible Unsupported Length STL16 to STL50

Loading 2 - Side carrier

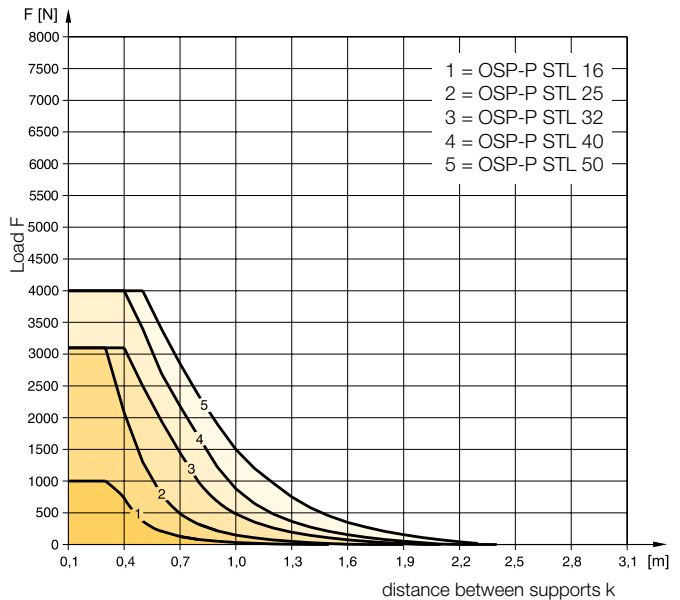

Variable Stop

Type VS16 to VS50

Arrangement with two variable stops

The variable stop Type VS provides simple stroke limitation. It can be retrofitted and positioned anywhere along the stroke length.

For every cylinder diameter two types of shock absorber are available – see „Shock Absorber Selection“.

Mid-section supports and magnetic switches can still be fitted on the same side as the variable stop.

Depending on the application, two variable stops can be fitted if required.

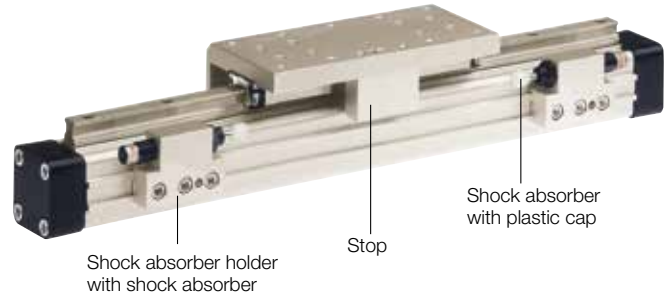

Shock Absorber Selection

The shock absorber is selected in dependence on the mass and speed.

The mass of the carrier itself must be taken into account.

Shock Absorber Selection in Dependence on Mass and Speed for Series OSP-STL16

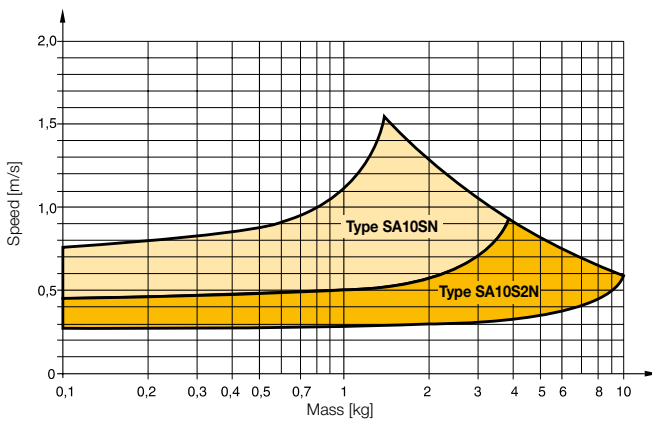

The values relate to an effective driving force of 78 N (6 bar)

Shock Absorber Selection in Dependence on Mass and Speed for Series OSP-STL25

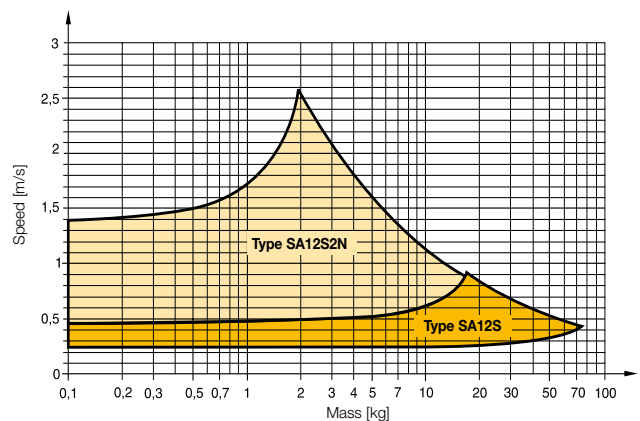

The values relate to an effective driving force of 250 N (6 bar)

OSP-P Modular Pneumatic Linear Drive Systems

Shock Absorber Selection in Dependence on Mass and Speed for Series OSP-STL32

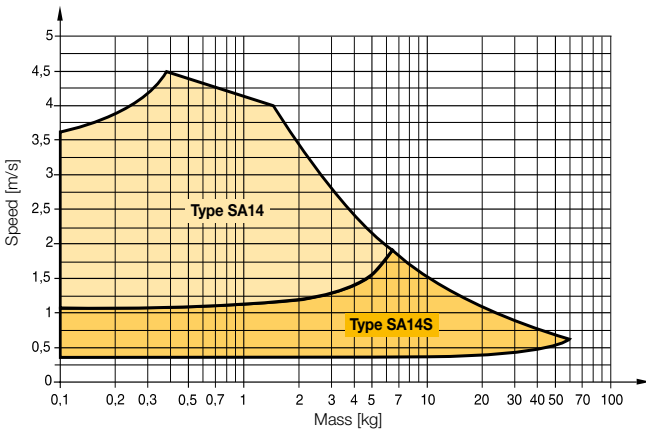

The values relate to an effective driving force of 420 N (6 bar)

Shock Absorber Selection in Dependence on Mass and Speed for Series OSP-STL40

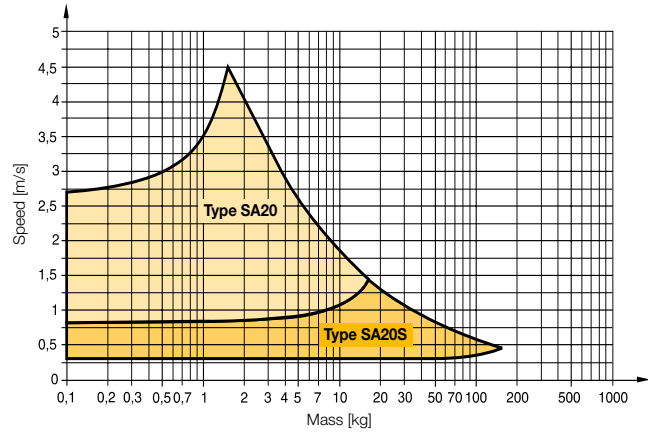

The values relate to an effective driving force of 640 N (6 bar)

Shock Absorber Selection in Dependence on Mass and Speed for Series OSP-STL50

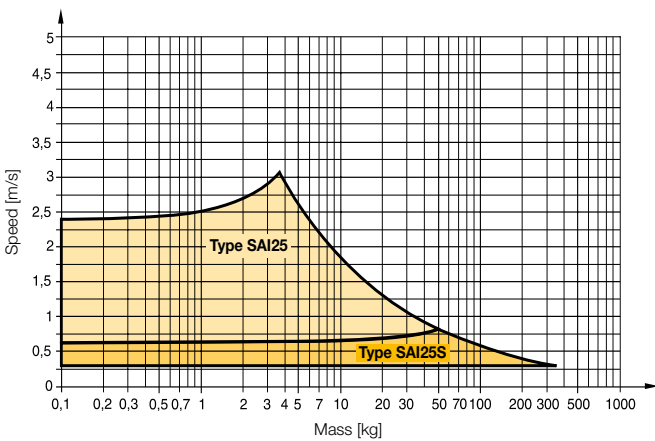

The values relate to an effective driving force of 1000 N (6 bar)

Dimensions - Variable Stop Type VS16 to VS50

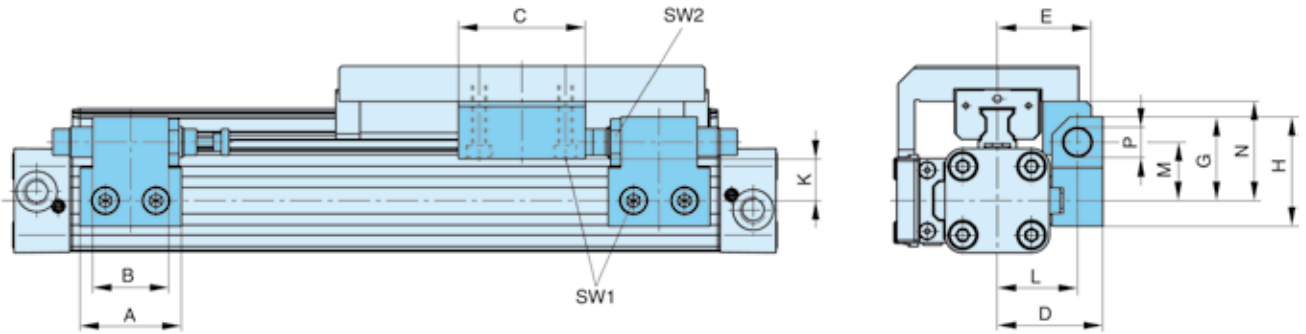

Dimension [mm] – Variable Stop Type VS16 to VS50

Series	Type	A	B	C	D	E	G	H	K	L	M	N	P	SW1	SW2
OSP-STL16	VS16	30	14	25	33	30	28	38	16.2	25.5	20.5	30	M10x1	4	12.5
OSP-STL25	VS25	40	30	50	41.5	37	33	43	18	31.5	23	39	M12x1	5	16
OSP-STL32	VS32	60	40	50	45.5	42	35	45	19	35.5	25	48	M14x1.5	5	17
OSP-STL40	VS40	84	52	60	64	59	48	63	25.6	50	34	58.6	M20x1.5	5	24
OSP-STL50	VS50	84	-	60	75	69	55	70	26.9	57	38	66.9	M25x1.5	5	30

Order information - Variable Stop Type VS16 to VS50 - without cylinder and without guide

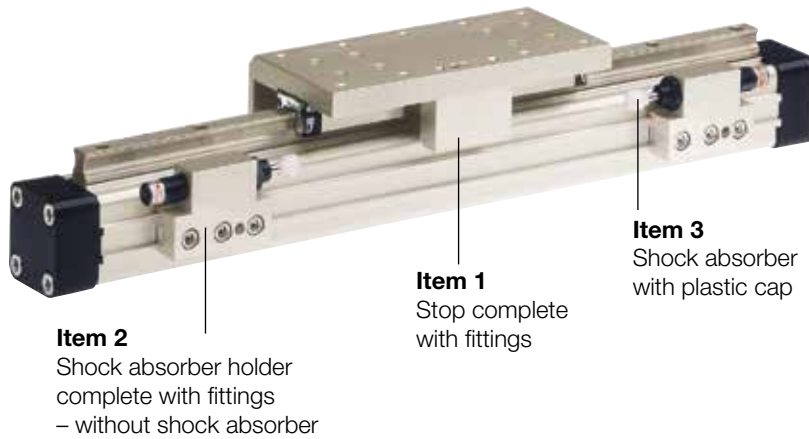

Item	Description	Size									
		VS16		VS25		VS32		VS40		VS50	
		Type	Order No.	Type	Order No.	Type	Order No.	Type	Order No.	Type	Order No.
1	Stop, complete	-	21196FIL	-	21197FIL	-	21198FIL	-	21199FIL	-	21200FIL
2	Shock absorber holder complete	-	21201FIL	-	21202FIL	-	21203FIL	-	21204FIL	-	21205FIL
3*	Shock absorber, soft	SA10SN	7718FIL	SA12S2N	7723FIL	SA14	7708FIL	SA20	7710FIL	SAI25	7712FIL
	Shock absorber, hard	SA10S2N	7721FIL	SA12S	7707FIL	SA14S	7709FIL	SA20S	7711FIL	SAI25S	7713FIL

* Shock absorber with plastic cap

Note: Order instructions for VS in combination with the cylinder and guide see page 64, pos.18

Order Instructions- STARLINE

1-4	5+6	7	8	9	10	11	12-16	17	18	19	20	21	22	23	24	25
OSPP	25	0	0	0	0	0	01100	0	0	0	0	0	0	0	0	0

Piston-Ø

16
25
32
40
50

Stroke
 Input in mm
 (5 digits)

Piston Mounting

0	without
---	---------

Measuring system

0	without
X	SFI 0.1 mm
Y	SFI 1 mm

Screws

0	standard
---	----------

Cushioning

0	standard
1	max. length ³⁾
2	VS variable stop, soft left for Starline
3	VS variable stop, hard, left for Starline
4	VS variable stop, soft, right for Starline
5	VS variable stop, hard, right for Starline
6	VS variable stop, soft, both sides for Starline
7	VS variable stop, hard, both sides for Starline

Version / Piston

0	standard
1	Tandem

Lubrication

0	standard
1	Slow speed ²⁾³⁾

Cover / Cable Channel

0	standard
1	cable channel
2	cable channel two-sided
X	without Cover rail

Air Connection

0	standard
1	on the end face
2	both at one end (not turnable)
3	left standard right end face
4	right standard left end face
A	3/2 way valve VOE 24 V= Ø 25, 32, 40, 50
B	3/2 way valve VOE 230 V~/110 V= Ø 25, 32, 40, 50
C	3/2 way valve VOE 48 V= Ø 25, 32, 40, 50
E	3/2 way valve VOE 110 V~ Ø 25, 32, 40, 50

Seals

0	standard (NBR)
1	Viton ^{® 1)}

End cap position

0	l+r0° = in front
1	l+r90° = underneath
2	l+r180° = at the back
3	l+r270° = same side as outerband
4	l90° = underneath; r0° = in front
5	l180° = at the back; r0° = in front
6	l270° = same side as outerband; r0° = in front
7	l0° = in front; r90° = underneath
8	l180° = at the back; r90° = underneath
9	l270° = same side as outerband; r90° = underneath
A	l0° = in front; r180° = at the back
B	l90° = underneath; r180° = at the back
C	l270° = same side as outerband; r180° = at the back
D	l0° = in front; r270° = same side as outerband
E	l90° = underneath; r270° = same side as outerband
F	l180° = at the back; r270° = same side as outerband

Guides/ Brakes/ Inversion

0	without
B	Starline STL

add. Guide Carriage

0	without
B	Guide Carriage Starline STL

¹⁾ Viton with VOE not possible.

²⁾ "Slow speed lubrication" in combination with „Viton[®]“ seals on demand.

³⁾ „Lubrication slow speed“ in combination with „max. cushioning length“ not possible.

OSP-P Modular Pneumatic Linear Drive Systems

Recirculating Ball Bearing Guide Series KF16 to KF50 for Linear Drive

Features:

- Anodized aluminium guide carriage, the mounting dimensions correspond to FESTO Type: DGPL-KF
- Polished and hardened steel guide rail
- For high loads in all directions
- High precision
- Integrated wiper system
- Integrated grease nipples
- Any length of stroke up to 3700 mm



- Maximum speed
 KF16, KF40: v = 3 m/s
 KF25, KF32, KF50: v = 5 m/s

Loads, Forces and Moments

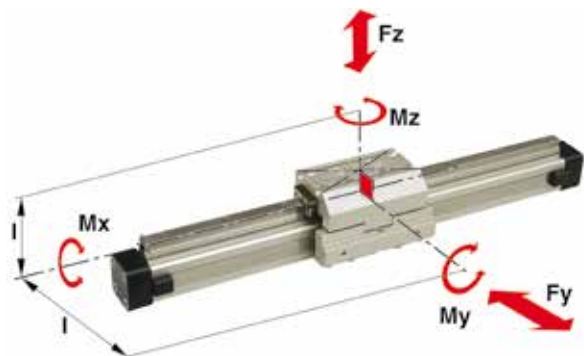

Technical Data

The table shows the maximal permissible loads. If multiple moments and forces act upon the cylinder simultaneously, the following equation applies:

$$\frac{M_x}{M_{x_{max}}} + \frac{M_y}{M_{y_{max}}} + \frac{M_z}{M_{z_{max}}} + \frac{F_y}{F_{y_{max}}} + \frac{F_z}{F_{z_{max}}} \leq 1$$

The sum of the loads should not exceed >1.

The table shows the maximum permissible values for light, shock-free operation, which must not be exceeded even under dynamic conditions.

Variable Stop

The variable stop Type VS provides simple stroke limitation. It can be retrofitted and positioned anywhere along the stroke length. For every cylinder diameter two types of shock absorber are available. Mid-section supports and magnetic switches can still be fitted on the same side as the variable stop.

Depending on the application, two variable stops can be fitted if required.

Variable Stop Type VS16 to VS50

Arrangement with two variable stops



* Please note:

The mass of the carriage has to be added to the total moving mass when using the cushioning diagram

Series	For linear drive	Max. moment [Nm]			Max. loads [N]		Mass of linear drive with guide [kg]		Mass* guide carriage [kg]	Groove stone	Order-No.	
		Mx	My	Mz	Fy	Fz	with 0mm stroke	increase per 100mm stroke			Thread size	Groove Stone
KF16	OSP-P16	12	25	25	1000	1000	0.558	0.21	0.228	-	-	21101
KF25	OSP-P25	35	90	90	3100	3100	1.522	0.369	0.607	M5	13508FIL	21102
KF32	OSP-P32	44	133	133	3100	3100	2.673	0.526	0.896	M5	13508FIL	21103
KF40	OSP-P40	119	346	346	4000	7100	4.167	0.701	1.531	M6	13509FIL	21104
KF50	OSP-P50	170	480	480	4000	7500	7.328	0.936	2.760	M8	13510FIL	21105

** Please use this order pattern: Order-No. + „stroke in mm“ (5 digits)
 Example: KF guide D16 mm, stroke 1000 mm: 21101-01000



Dimensions - Series OSP-P KF16 to KF50

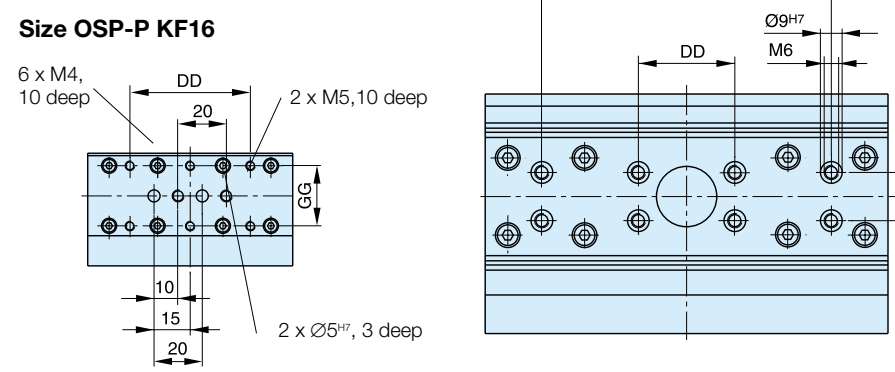
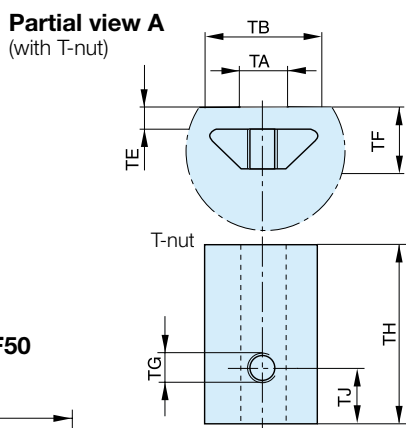
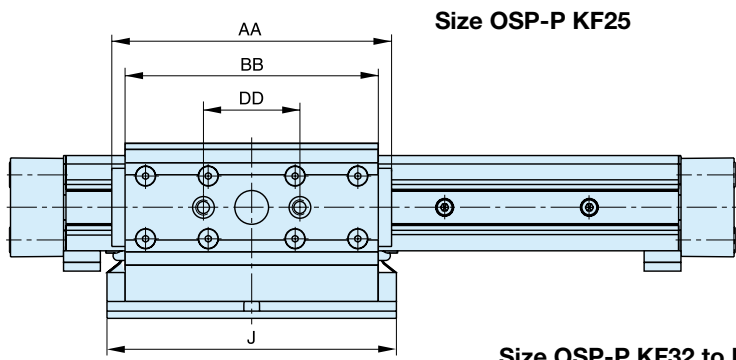
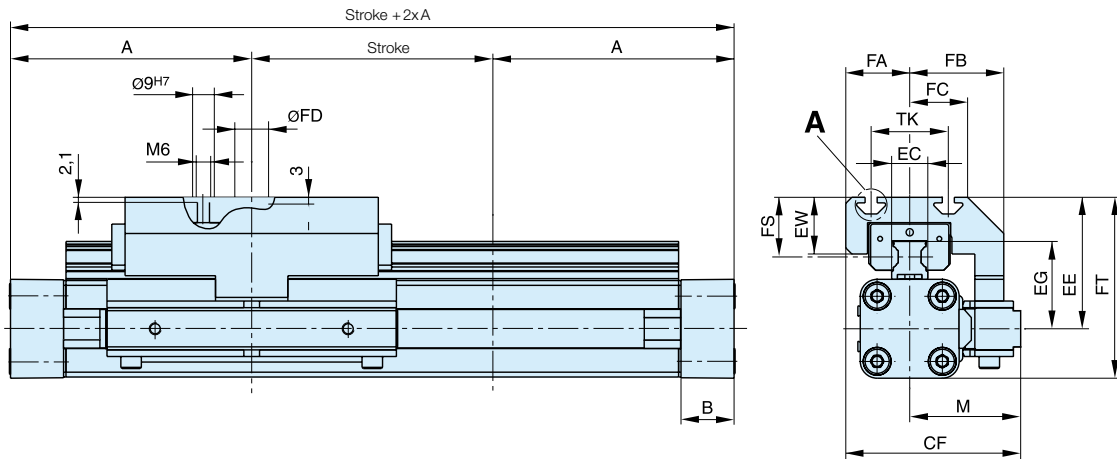

Dimensions [mm] Series OSP-P KF16, KF25, KF32, KF40, KF50

Series	A	B	J	AA	BB	CF	DD	EC	EE	EG	EW	JJ	GG	M
KF16	65	14	76	93	85	48	50	15	41	24.6	10	-	25	30
KF25	100	22	120	120.2	105	72.5	40	15	54.5	36.2	23.5	-	-	46
KF32	125	25.5	160	146.2	131	93.8	40	15	60.5	42.2	23.5	-	20	59.8
KF40	150	28	150	188.5	167	103.3	40	20	69.5	51.6	26.5	120	20	60.8
KF50	175	33	180	220.2	202	121	40	23	90.5	62.3	32.5	120	40	69

Series	FA	FB	FC	FD	FT	FS	TA	TB	TE	TF	TG	TH	TJ	TK
KF16	17.7	29	16.5	-	56	19	-	-	-	-	-	-	-	-
KF25	26.5	39	24	14 ^{G7}	75	24.7	5	12.1	2.3	6.9	M5	11.5	4	32
KF32	34	53.8	34	25 ^{G7}	86.5	24.7	5	12.1	1.8	6.4	M5	11.5	4	47
KF40	42.5	56.8	41	25 ^{G7}	104	26	6	12.8	1.8	8.4	M6	17	5.5	55
KF50	52	65	50	25 ^{G7}	134	38	8	21.1	4.5	12.5	M8	23	7.5	72



Mid-Section Support

Mid-section supports are required from a certain stroke length to prevent excessive deflection and vibration of the linear drive. The diagrams show the maximum permissible unsupported length in relation to loading. A distinction must be drawn between loading 1 and loading 2.

Deflection of 0.5 mm max. between supports is permissible.

Note

For speeds $v > 0.5$ m/s the distance between supports should not exceed 1m.

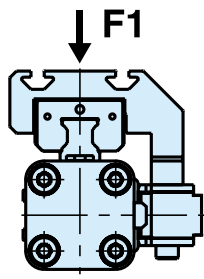

Loading 1
Top carrier

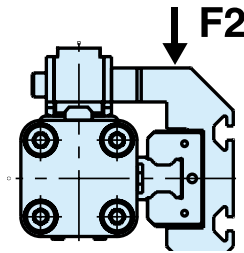

Loading 2
Side carrier

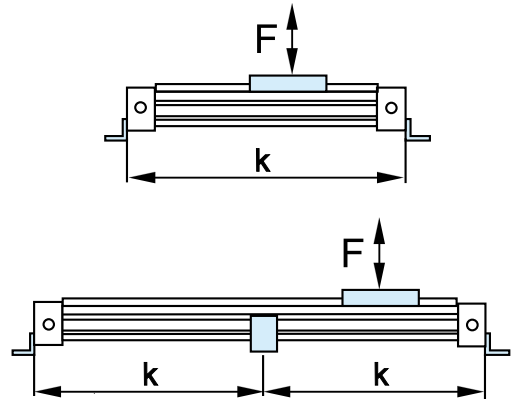

Permissible Unsupported Length OSP-P KF16 to KF50

Loading 1 - Top carrier

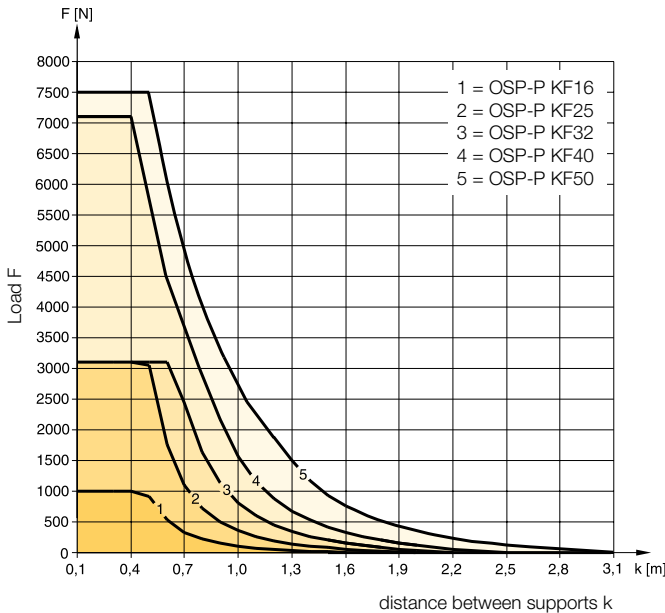

Permissible Unsupported Length OSP-P KF16 to KF50

Loading 2 - Side carrier

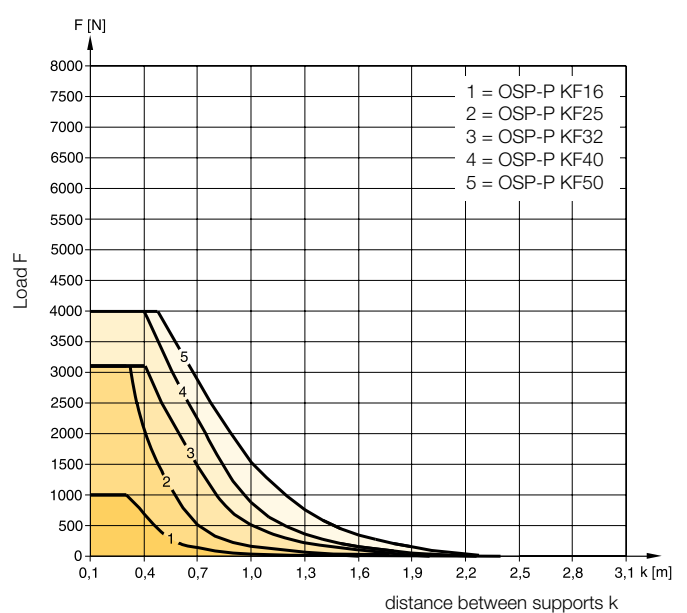

Variable Stop

Type VS16 to VS50

Arrangement with two variable stops

The variable stop Type VS provides simple stroke limitation. It can be retrofitted and positioned anywhere along the stroke length.

For every cylinder diameter two types of shock absorber are available

– see „Shock Absorber Selection“ below.

Mid-section supports and magnetic switches can still be fitted on the same side as the variable stop.

Depending on the application, two variable stops can be fitted if required.

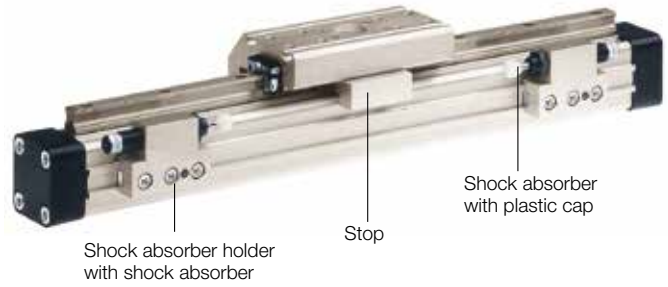

Shock Absorber Selection

The shock absorber is selected in dependence on the mass and speed.

The mass of the carrier itself must be taken into account.

Shock Absorber Selection in Dependence on Mass and Speed for Series OSP-KF16

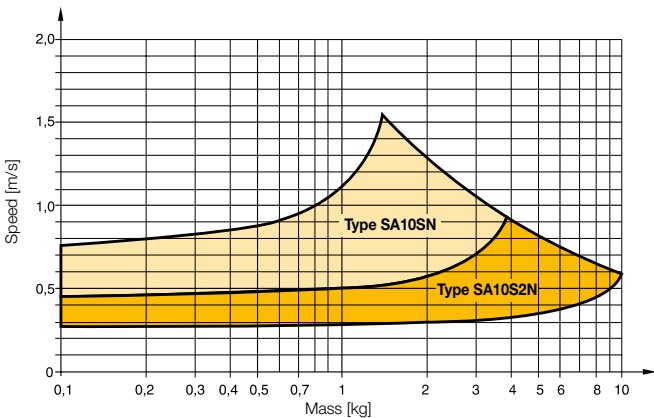

The values relate to an effective driving force of 78 N (6 bar)

Shock Absorber Selection in Dependence on Mass and Speed for Series OSP-KF25

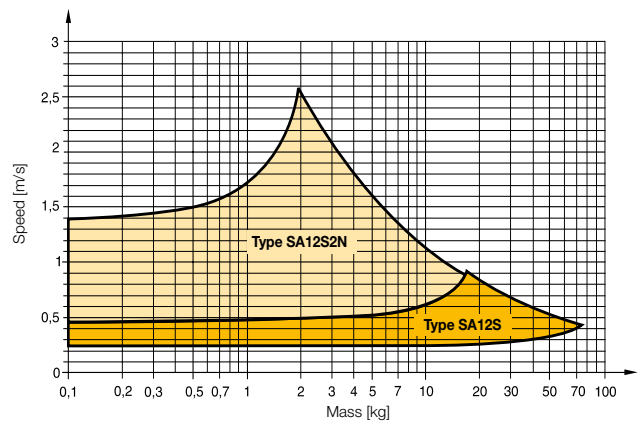

The values relate to an effective driving force of 250 N (6 bar)

OSP-P Modular Pneumatic Linear Drive Systems

Shock Absorber Selection in Dependence on Mass and Speed for Series OSP-KF32

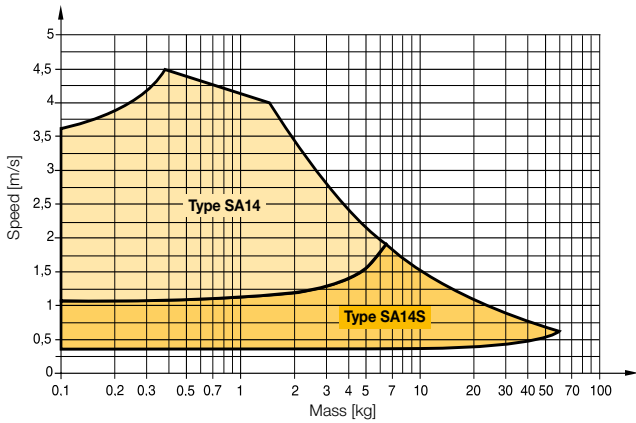

The values relate to an effective driving force of 420 N (6 bar)

Shock Absorber Selection in Dependence on Mass and Speed for Series OSP-KF40

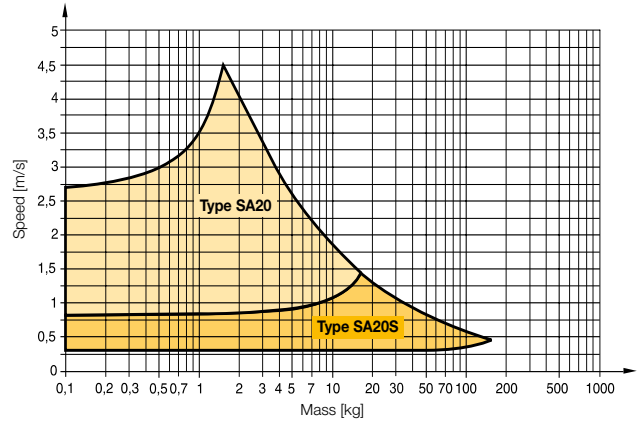

The values relate to an effective driving force of 640 N (6 bar)

Shock Absorber Selection in Dependence on Mass and Speed for Series OSP-KF50

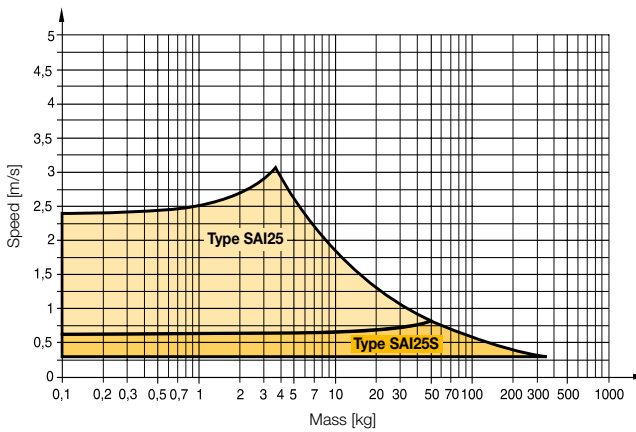

The values relate to an effective driving force of 1000 N (6 bar)

Dimensions - Variable Stop Type VS16 to VS50

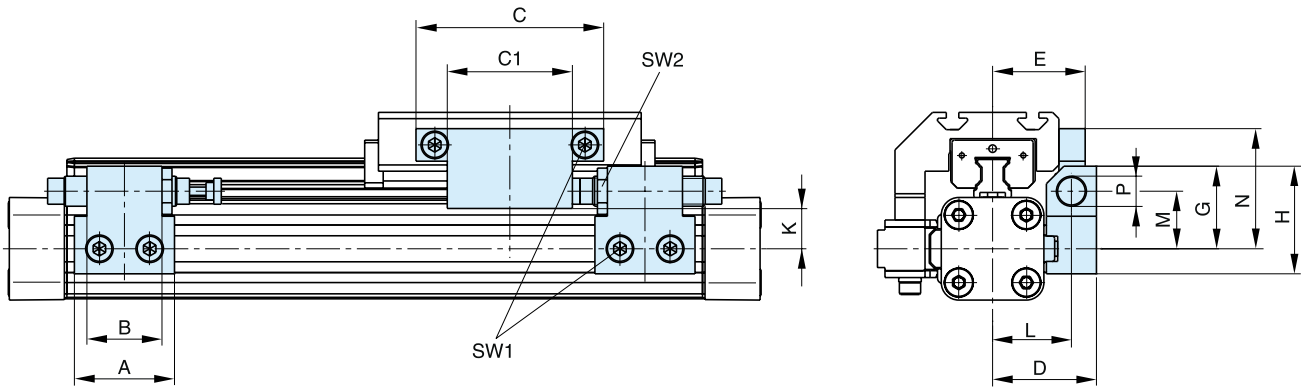

Dimension [mm] – Variable Stop Type VS16 to VS50

Series	Type	A	B	C	C1	D	E	G	H	K	L	M	N	P	SW1	SW2
OSP-KF16	VS16	30	14	50	25	33	29.7	28	38	16.2	25.5	20.5	40.5	M10 x 1	4	12.5
OSP-KF25	VS25	40	30	75	50	41.5	37	33	43	18	31.5	23	48	M12 x 1	5	16
OSP-KF32	VS32	60	40	50	-	45.5	41.5	35	45	19	35.5	25	37	M14 x 1.5	5	17
OSP-KF40	VS40	84	52	60	-	64	59	48	63	25.5	50	34	43	M20 x 1.5	5	24
OSP-KF50	VS50	84	-	60	-	75	69	55	70	26.9	57	38	58	M25 x 1.5	5	30

Order information - Variable Stop Type VS16 to VS50

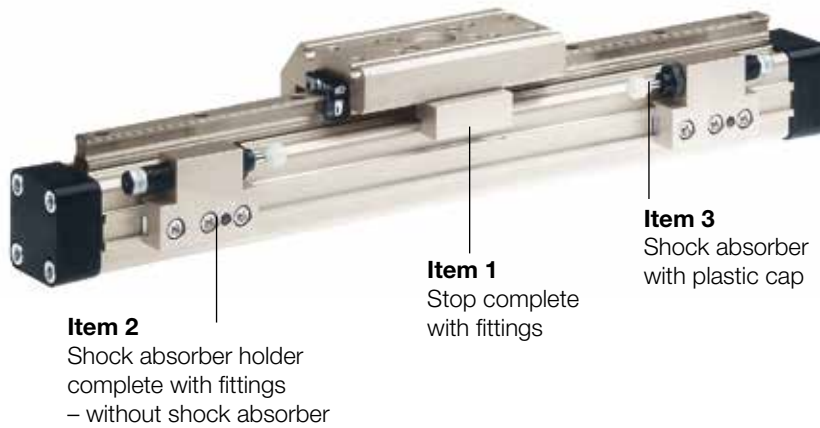

Item Description	Size									
	VS16		VS25		VS32		VS40		VS50	
	Type	Order No.	Type	Order No.	Type	Order No.	Type	Order No.	Type	Order No.
1 Stop, complete	-	21186FIL	-	21187FIL	-	21188FIL	-	21189FIL	-	21290FIL
2 Shock absorber holder complete	-	21201FIL	-	21202FIL	-	21203FIL	-	21204FIL	-	21205FIL
3* Shock absorber, soft	SA10SN	7718FIL	SA12S2N	7723FIL	SA14	7708FIL	SA20	7710FIL	SAI25	7712FIL
3* Shock absorber, hard	SA10S2N	7721FIL	SA12S	7707FIL	SA14S	7709FIL	SA20S	7711FIL	SAI25S	7713FIL

* Shock absorber with plastic cap

Note: Order instructions for VS in combination with the cylinder and guide see page 71, pos. 18

Order Instructions- KF

1-4	5+6	7	8	9	10	11	12-16	17	18	19	20	21	22	23	24	25
OSP	25	0	0	0	0	0	01100	0	0	0	0	0	0	0	0	0

Piston-Ø

16
25
32
40
50

Stroke

Input in mm (5 digits)

Piston Mounting

0	without
---	---------

Measuring system

0	without
X	SFI 0.1 mm
Y	SFI 1 mm

Screws

0	standard
---	----------

Cushioning

0	standard
1	max. length ³⁾
2	VS variable stop, soft left for KF
3	VS variable stop, hard, left for KF
4	VS variable stop, soft, right for KF
5	VS variable stop, hard, right for KF
6	VS variable stop, soft, both sides for KF
7	VS variable stop, hard, both sides for KF

Version / Piston

C	Classic
T	Classic Tandem

Lubrication

0	standard
1	Slow speed ²⁾³⁾

Cover / Cable Channel

0	standard
1	cable channel
2	cable channel two-sided
X	without Cover rail

Air Connection

0	standard
1	on the end face
2	both at one end (not turnable)
3	left standard right end face
4	right standard left end face
A	3/2 way valve VOE 24 V = Ø25,32,40, 50
B	3/2 way valve VOE 230 V~/110 V= Ø25, 32, 40, 50
C	3/2 way valve VOE 48 V= Ø25, 32, 40, 50
E	3/2 way valve VOE 110 V~ Ø25, 32, 40, 50

Seals

0	standard (NBR)
1	Viton ^{® 1)}

End cap position

0	l+r 0° = in front
1	l+r 90° = underneath
2	l+r 180° = at the back
3	l+r 270° = same side as outerband
4	l 90° = underneath; r 0° = in front
5	l 180° = at the back; r 0° = in front
6	l 270° = same side as outerband; r 0° = in front
7	l 0° = in front; r 90° = underneath
8	l 180° = at the back; r 90° = underneath
9	l 270° = same side as outerband; r 90° = underneath
A	l 0° = in front; r 180° = at the back
B	l 90° = underneath; r 180° = at the back
C	l 270° = same side as outerband; r 180° = at the back
D	l 0° = in front; r 270° = same side as outerband
E	l 90° = underneath; r 270° = same side as outerband
F	l 180° = at the back; r 270° = same side as outerband

Guides/ Brakes/ Inversion

0	without
C	KF

add. Guide Carriage

0	without
C	Guide Carriage KF

End cap position (air connection)

Cylinder L (left end side)

Cylinder R (right end side)

¹⁾ Viton with VOE not possible.

²⁾ "Slow speed lubrication" in combination with „Viton[®]“ seals on demand.

³⁾ „Lubrication slow speed“ in combination with „max. cushioning length“ not possible.

**Heavy Duty Guide
HD**

Series HD25 to HD50 for Linear Drive

Features:

- Guide system: 4-row recirculating ball bearing guide
- Polished and hardened steel guide rail
- For highest loads in all directions
- Highest precision
- Integrated wiper system
- Integrated grease nipples
- Any lengths of stroke up to 3700 mm (longer strokes on request)
- Anodized aluminium guide carriage - dimensions compatible with OSP guide GUIDELINE
- Maximum speed $v = 5 \text{ m/s}$

Loads, Forces and Moments

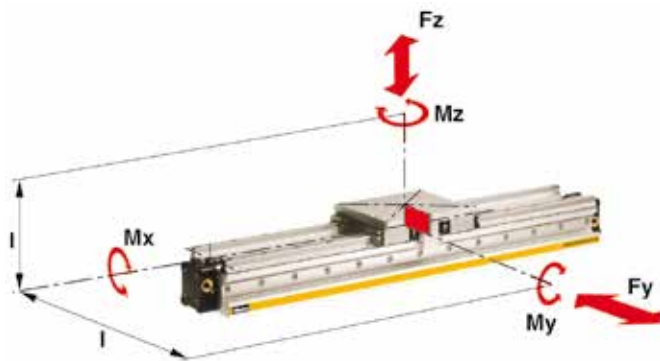

Technical Data

The table shows the maximal permissible loads. If multiple moments and forces act upon the cylinder simultaneously, the following equation applies:

$$\frac{M_x}{M_{x_{max}}} + \frac{M_y}{M_{y_{max}}} + \frac{M_z}{M_{z_{max}}} + \frac{F_y}{F_{y_{max}}} + \frac{F_z}{F_{z_{max}}} \leq 1$$

The sum of the loads should not exceed >1.

The table shows the maximum permissible values for light, shock-free operation, which must not be exceeded even under dynamic conditions.

Series	For linear drive	Max. moment [Nm]			Max. loads [N]		Mass of linear drive with guide carriage [kg]		Mass* guide [kg]	Order-No. ** HD Guide without cylinder
		Mx	My	Mz	Fy	Fz	with 0 mm stroke	increase per 100 mm stroke		
HD 25	OSP-P25	260	320	320	6000	6000	3.065	0.924	1.289	21246
HD 32	OSP-P32	285	475	475	6000	6000	4.308	1.112	1.367	21247
HD 40	OSP-P40	800	1100	1100	15000	15000	7.901	1.748	2.712	21248
HD 50	OSP-P50	1100	1400	1400	18000	18000	11.648	2.180	3.551	21249

** Please use this order pattern: Order-No. + „stroke in mm“ (5 digits)
Example: HD Guide D25 mm, stroke 1000 mm: 21246-01000



Options:

- With variable stop
- With intermediate stop module

Version with pneumatic linear drive series OSP-P

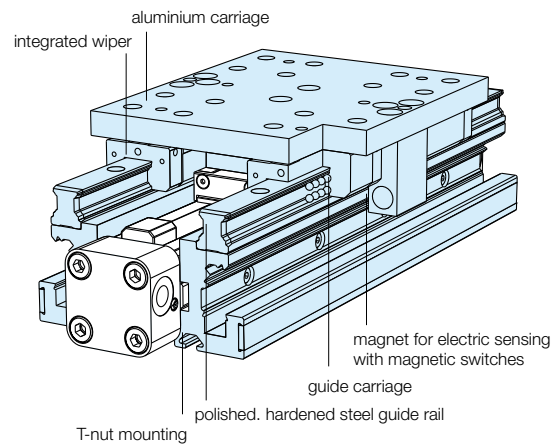

Variable Stop

Variable Stop Type VS25 to VS50

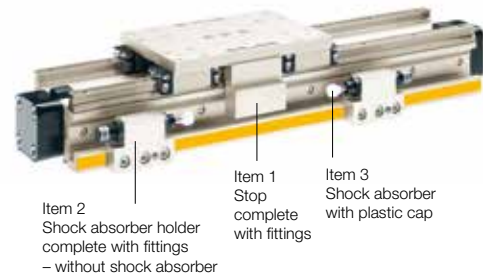

*** Please note:**

The mass of the carriage has to be added to the total moving mass when using the cushioning diagram



OSP-P Modular Pneumatic Linear Drive Systems

Dimensions

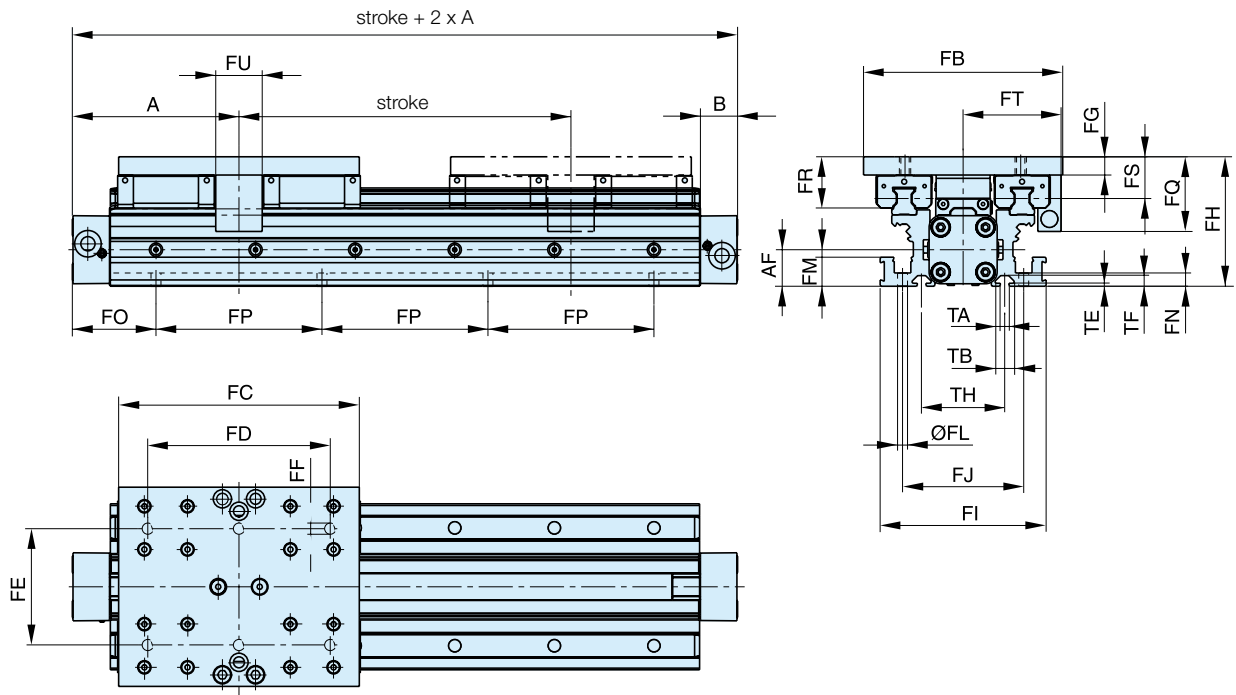

Note:

The HD heavy duty guide must be mounted on a flat surface for its entire length.

If T-grooves or T-bolts are used, the distance between them should not exceed 100 mm.

Variable Stop Type VS25 to VS50

The variable stop provides simple stroke limitation and can be supplied mounted on the right or left, as required.

Incremental displacement measuring system ORIGA-Sensoflex Series SFI-plus

can be supplied mounted on the right or left, as required.

Arrangement of magnetic switches:

Magnetic switches can be fitted anywhere on either side.

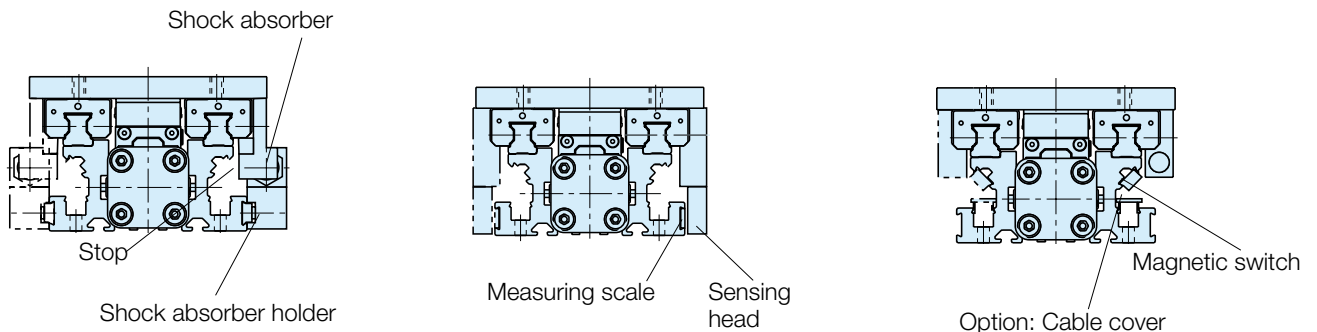

OSP-P Modular Pneumatic Linear Drive Systems

Dimensions [mm]

Series	A	B	AF	FB	FC	FD	FE	FF	FG	FH	FI	FJ	ØFL
HD25	100	22	22	120	145	110	70	M6	11	78	100	73	6
HD32	125	25.5	30	120	170	140	80	M6	11	86	112	85	6
HD40	150	28	38	160	180	140	110	M8	14	108	132	104	7.5
HD50	175	33	48	180	200	160	120	M8	14	118	150	118	7.5
Series	FM	FN	FP	FQ	FR	FS	FT	FU	TA	TB	TE	TF	TH
HD25	17.5	8	100	45	31	25	59	28	5.2	11.5	1.8	6.4	50
HD32	17.5	8	100	45	31	25	63	30	5.2	11.5	1.8	6.4	60
HD40	22	10	100	58	40	31.5	76	30	8.2	20	4.5	12.3	66
HD50	22	10	100	58	44	35.5	89	30	8.2	20	4.5	12.3	76

FO		OSP-P			
x	HD25	HD32	HD40	HD50	
00	50.0	75.0	50.0	75.0	
01	50.5	75.5	50.5	75.5	
02	51.0	76.0	51.0	76.0	
03	51.5	76.5	51.5	76.5	
04	52.0	77.0	52.0	77.0	
05	52.5	77.5	52.5	77.5	
06	53.0	78.0	53.0	78.0	
07	53.5	78.5	53.5	78.5	
08	54.0	79.0	54.0	79.0	
09	54.5	79.5	54.5	79.5	
10	55.0	80.0	55.0	80.0	
11	55.5	80.5	55.5	80.5	
12	56.0	81.0	56.0	81.0	
13	56.5	81.5	56.5	81.5	
14	57.0	82.0	57.0	82.0	
15	57.5	82.5	57.5	82.5	
16	58.0	83.0	58.0	83.0	
17	58.5	83.5	58.5	83.5	
18	59.0	84.0	59.0	84.0	
19	59.5	84.5	59.5	84.5	
20	60.0	85.0	60.0	85.0	
21	60.5	85.5	60.5	85.5	
22	61.0	86.0	61.0	86.0	
23	61.5	86.5	61.5	86.5	
24	62.0	87.0	62.0	87.0	
25	62.5	87.5	62.5	87.5	
26	63.0	88.0	63.0	88.0	
27	63.5	88.5	63.5	88.5	
28	64.0	89.0	64.0	89.0	
29	64.5	89.5	64.5	89.5	
30	65.0	90.0	65.0	90.0	
31	65.5	90.5	65.5	90.5	
32	66.0	91.0	66.0	91.0	
33	66.5	91.5	66.5	91.5	
34	67.0	92.0	67.0	92.0	
35	67.5	92.5	67.5	92.5	
36	68.0	93.0	68.0	93.0	
37	68.5	93.5	68.5	93.5	
38	69.0	94.0	69.0	94.0	
39	69.5	94.5	69.5	94.5	
40	70.0	95.0	70.0	95.0	
41	70.5	95.5	70.5	95.5	
42	71.0	96.0	71.0	96.0	
43	71.5	96.5	71.5	96.5	
44	72.0	97.0	72.0	97.0	
45	72.5	97.5	72.5	97.5	
46	73.0	98.0	73.0	98.0	
47	73.5	98.5	73.5	98.5	
48	74.0	99.0	74.0	99.0	
49	74.5	99.5	74.5	99.5	

FO		OSP-P			
x	HD25	HD32	HD40	HD50	
50	75.0	50.0	75.0	50.0	
51	75.5	50.5	75.5	50.5	
52	76.0	51.0	76.0	51.0	
53	76.5	51.5	76.5	51.5	
54	77.0	52.0	77.0	52.0	
55	77.5	52.5	77.5	52.5	
56	78.0	53.0	78.0	53.0	
57	78.5	53.5	78.5	53.5	
58	79.0	54.0	79.0	54.0	
59	79.5	54.5	79.5	54.5	
60	80.0	55.0	80.0	55.0	
61	80.5	55.5	80.5	55.5	
62	81.0	56.0	81.0	56.0	
63	81.5	56.5	81.5	56.5	
64	82.0	57.0	82.0	57.0	
65	82.5	57.5	82.5	57.5	
66	83.0	58.0	83.0	58.0	
67	83.5	58.5	83.5	58.5	
68	84.0	59.0	84.0	59.0	
69	84.5	59.5	84.5	59.5	
70	85.0	60.0	85.0	60.0	
71	85.5	60.5	85.5	60.5	
72	86.0	61.0	86.0	61.0	
73	86.5	61.5	86.5	61.5	
74	87.0	62.0	87.0	62.0	
75	87.5	62.5	87.5	62.5	
76	88.0	63.0	88.0	63.0	
77	88.5	63.5	88.5	63.5	
78	89.0	64.0	89.0	64.0	
79	89.5	64.5	89.5	64.5	
80	90.0	65.0	90.0	65.0	
81	90.5	65.5	90.5	65.5	
82	91.0	66.0	91.0	66.0	
83	91.5	66.5	91.5	66.5	
84	92.0	67.0	92.0	67.0	
85	92.5	67.5	92.5	67.5	
86	93.0	68.0	93.0	68.0	
87	93.5	68.5	93.5	68.5	
88	94.0	69.0	94.0	69.0	
89	94.5	69.5	94.5	69.5	
90	95.0	70.0	95.0	70.0	
91	95.5	70.5	95.5	70.5	
92	96.0	71.0	96.0	71.0	
93	96.5	71.5	96.5	71.5	
94	97.0	72.0	97.0	72.0	
95	97.5	72.5	97.5	72.5	
96	98.0	73.0	98.0	73.0	
97	98.5	73.5	98.5	73.5	
98	99.0	74.0	99.0	74.0	
99	99.5	74.5	99.5	74.5	

Note:

the dimension FO is derived from the last two digits of the stroke:

Example:

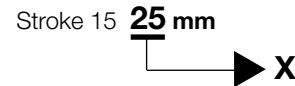

For a cylinder OSP-P25 the adjacent table indicates that for x = 25 mm: FO = 62.5 mm

Dimensions - Variable Stop Type VS25 to VS50

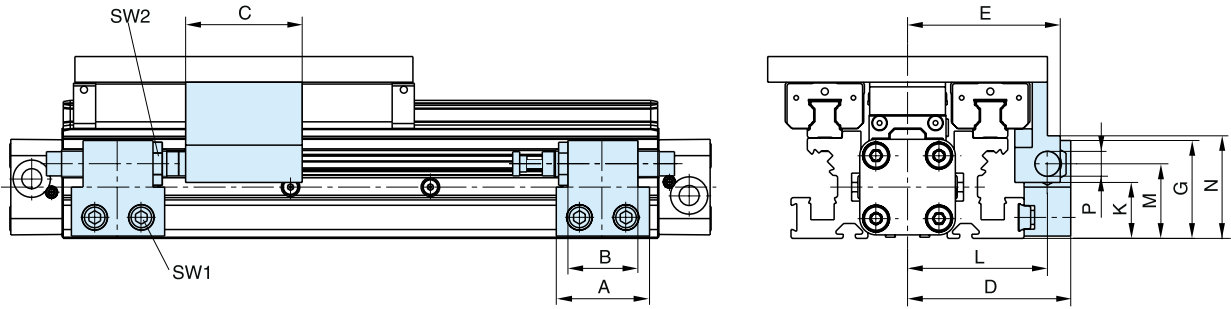

Dimension [mm] – Variable Stop Type VS25 to VS50

Series	Type	A	B	C	D	E	G	K	L	M	N	P	SW1	SW2
OSP-HD25	VS25	40	30	50	70	65.5	42	26	60	32	42	M12 x 1	5	16
OSP-HD32	VS32	60	40	54	73	71	44	28	63	34	53	M14 x 1.5	5	17
OSP-HD40	VS40	84	52	55	96	92	59	35	82	45	61	M20 x 1.5	5	24
OSP-HD50	VS50	84	-	60	107	105	66	37	89	49	66	M25 x 1.5	5	30

Order information - Variable Stop Type VS25 to VS50 - without cylinder and HD-guide

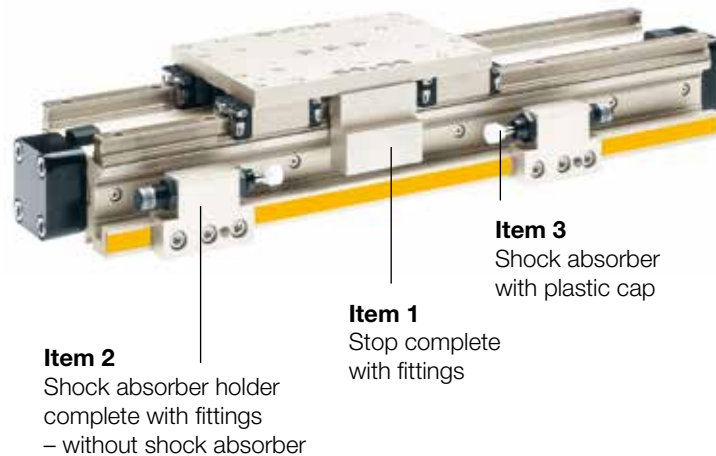

Item	Description	Size							
		VS25		VS32		VS40		VS50	
		Type	Order-No.	Type	Order-No.	Type	Order-No.	Type	Order-No.
1	Stop, complete	-	21257FIL	-	21258FIL	-	21259FIL	-	21260FIL
2	Shock absorber holder, complete	-	21202FIL	-	21203FIL	-	21204FIL	-	21205FIL
3*	Shock absorber, soft	SA12S2N	7723FIL	SA14	7708FIL	SA20	7710FIL	SAI25	7712FIL
	Shock absorber, hard	SA12S	7707FIL	SA14S	7709FIL	SA20S	7711FIL	SAI25S	7713FIL

* Shock absorber with plastic cap

Note: Order instructions for VS in combination with the cylinder and HD guide see page 78, pos.18

Intermediate Stop Module

Type ZSM .. HD

The intermediate stop module ZSM allows the guide carriage to stop at any desired intermediate positions with high accuracy. It can be retrofitted. Depending on the application, i.e. the number of intermediate stops, one or more intermediate position stops can be used. The intermediate position stops can be retracted and extended without the need for the guide carriage to be moved back out of position.

Therefore the guide carriage can be made to stop at the defined intermediate positions in any order.

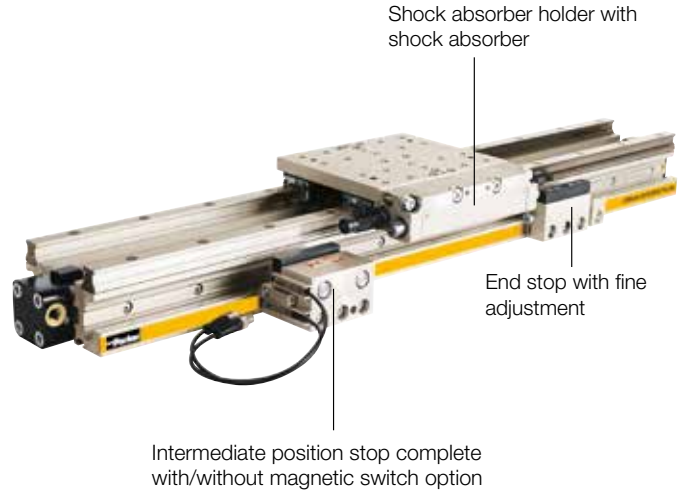

ORIGA intermediate stop module ZSM:

- Allows stopping at any intermediate positions
- Intermediate position stops can be located steplessly anywhere along the whole stroke length
- Movement to the next position without reverse stroke
- Compact unit
- Cost-effective positioning module without electrical or electronic components
- Option: end stop with fine adjustment

Operating information	
Operating pressure range:	4 - 8 bar
Temperature range:	-10°C to +70°C
Intermediate position grid	85 mm

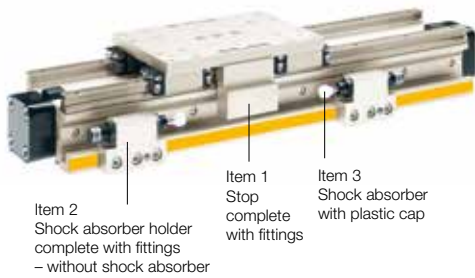

Shock Adsorbers Type SA14S

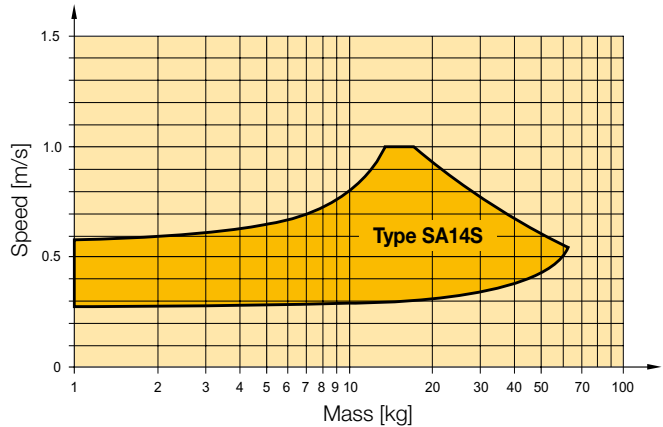

The values relate to an effective driving force of 250 N (6 bar)

Order Instructions - Intermediate Stop Module - Type ZSM..HD

Item	Description	For intermediate stop module	Order-No.
1*	Shock absorber holder with shock absorber SA14S, both sides	ZSM25HD	21342BFIL
2*	Shock absorber holder with shock absorber SA14S, left	ZSM25HD	21342LFIL
3*	Shock absorber holder with shock absorber SA14S, right	ZSM25HD	21342RFIL
4	Intermediate position stop complete, without magnetic switch option	ZSM25HD	21343FIL
5	Intermediate position stop complete, with magnetic switch option	ZSM25HD	21344FIL
6	End stop with fine adjustment	ZSM25HD	21346FIL

* The shock absorbers are installed in the shock absorber holder and adjusted in our workshop.

Note:

For movement onwards from the intermediate position, the intermediate position stop must advance. The intermediate position stop can only advance if both cylinder chambers of the OSP-P cylinder are pressurized.



Dimensions – intermediate stop module Type ZSM..HD

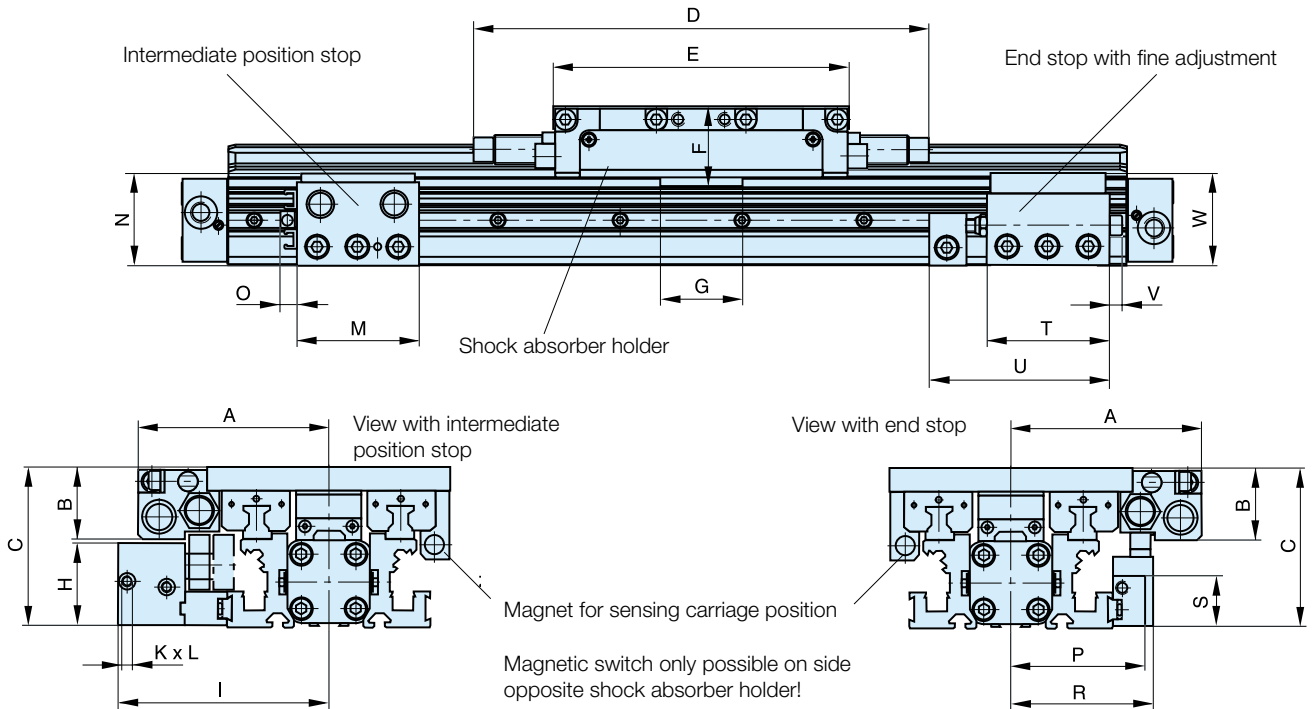

Dimension [mm] – Intermediate stop module Type ZSM..HD

Series	A	B	C	D	E	F	G	H	I	K	L	M	N	O	P	R	S	T	U	V	W
ZSM25	94	35	78	224	145	39	40	41	104	M5	5	60	45	8	66	70	26	60	93	6	46

Shock absorber arrangement in dependence on direction of movement

From right to left

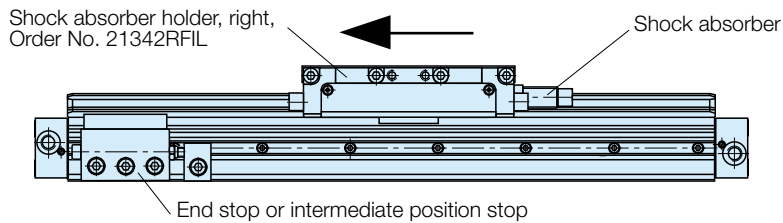

In both directions

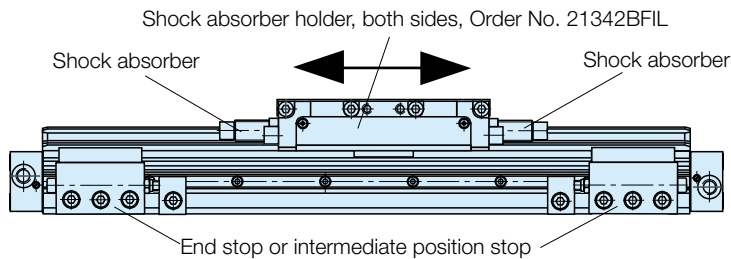

From left to right

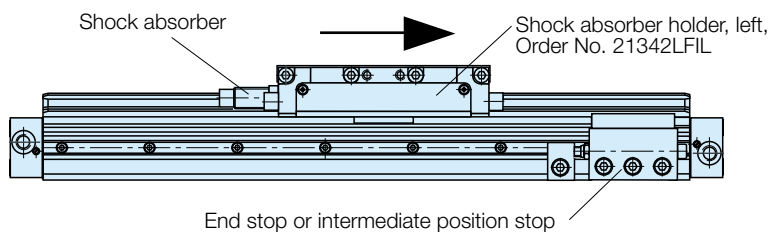

Order Instructions- HEAVY DUTY - HD

1-4	5+6	7	8	9	10	11	12-16	17	18	19	20	21	22	23	24	25
OSPP	25	0	0	0	0	0	01100	0	0	0	0	0	0	0	0	0

Piston-Ø

25
32
40
50

Stroke
 Input in mm
 (5 digits)

Piston Mounting

0	without
---	---------

Measuring system

0	without
X	SFI 0.1 mm
Y	SFI 1 mm

Screws

0	standard
---	----------

Cushioning

0	standard
1	max. length ³⁾
2	VS variable stop, soft left for HD
3	VS variable stop, hard, left for HD
4	VS variable stop, soft, right for HD
5	VS variable stop, hard, right for HD
6	VS variable stop, soft, both sides for HD
7	VS variable stop, hard, both sides for HD

Version / Piston

0	standard
1	Tandem

Lubrication

0	standard
1	Slow speed ²⁾

Cover / Cable Channel

0	standard
1	cable channel
2	cable channel two-sided
X	without Cover rail

Air Connection

0	standard
1	on the end face
2	both at one end (not turnable)
3	left standard right end face
4	right standard left end face
A	3/2 way valve VOE 24 V = Ø 25, 32, 40, 50
B	3/2 way valve VOE 230 V~/110 V = Ø 25, 32, 40, 50
C	3/2 way valve VOE 48 V = Ø 25, 32, 40, 50
E	3/2 way valve VOE 110 V~ Ø 25, 32, 40, 50

Seals

0	standard (NBR)
1	Viton ^{® 1)}

End cap position

0	l+r 0° = in front
1	l+r 90° = underneath
2	l+r 180° = at the back
3	l+r 270° = same side as outerband
4	l 90° = underneath; r 0° = in front
5	l 180° = at the back; r 0° = in front
6	l 270° = same side as outerband; r 0° = in front
7	l 0° = in front; r 90° = underneath
8	l 180° = at the back; r 90° = underneath
9	l 270° = same side as outerband; r 90° = underneath
A	l 0° = in front; r 180° = at the back
B	l 90° = underneath; r 180° = at the back
C	l 270° = same side as outerband; r 180° = at the back
D	l 0° = in front; r 270° = same side as outerband
E	l 90° = underneath; r 270° = same side as outerband
F	l 180° = at the back; r 270° = same side as outerband

Guides/ Brakes/ Inversion

0	without
D	HD

add. Guide Carriage

0	without
D	Guide Carriage HD

End cap position (air connection)

270° same side as outerband
180° at the back
end-face
0° in front
90° underneath
Cylinder R (right end side)

180° at the back
270° same side as outerband
end-face
0° in front
90° underneath
Cylinder L (left end side)

¹⁾ Viton with VOE not possible.

²⁾ "Slow speed lubrication" in combination with „Viton[®]“ seals on demand.

³⁾ „Lubrication slow speed“ in combination with „max. cushioning length“ not possible.



Active Brakes and Passive Brakes

Versions:

- ACTIVE Brake
- Plain bearing guide with integrated ACTIVE Brake
- Aluminium roller guide with integrated ACTIVE Brake
- Plain bearing guide with PASSIVE Brake
- Aluminium roller guide with PASSIVE Brake

Active Brake
for pneumatic linear drive
Series OSP-P
Piston diameters 25 - 80 mm.

See page 80



Slideline with Active Brake
Plain bearing guide SLIDELINE - SL
with integrated ACTIVE Brake
Piston diameters 25 - 50 mm.

See page 47



Proline with Active Brake
Aluminium roller guide
PROLINE - PL with
integrated ACTIVE Brake
Piston diameters 25 - 50 mm.

See page 50



Multibrake with Slideline
MULTI BRAKE – PASSIVE Brake
with plainbearing guide
SLIDELINE - SL
Piston diameter 25 - 80 mm.

See page 84



Multibrake with Proline
MULTI BRAKE – PASSIVE Brake with
aluminium roller guide
PROLINE - PL
Piston diameters 25 - 50 mm.

See page 87



Active Brake

Series AB25 to AB80 for Linear Drive



Features:

- Actuated by pressurisation
- Released by spring actuation
- Completely stainless version
- Holds position, even under changing load conditions



Function

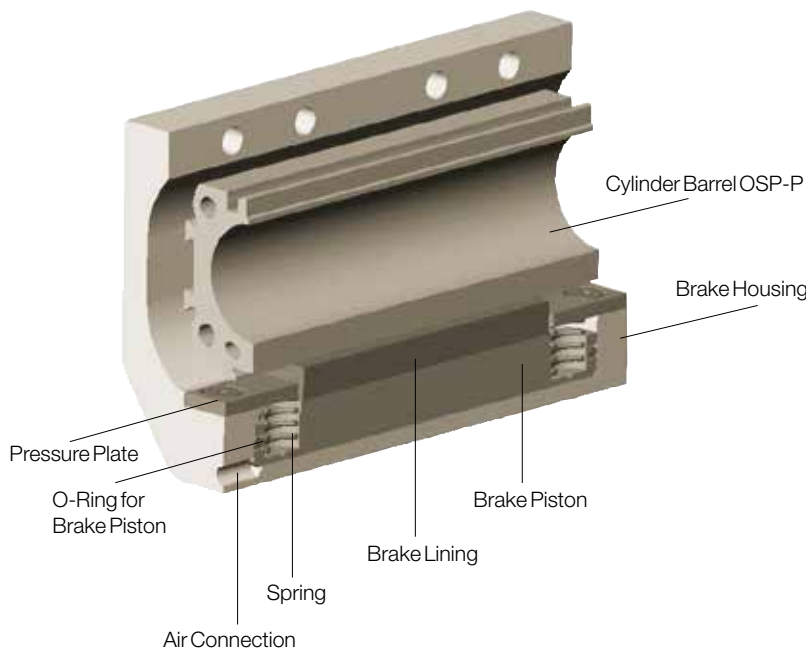

Forces and Weights

Series	For linear drive	Max. braking force [N] ⁽¹⁾	Brake pad way [mm]	Mass [kg]		
				Linear drive with brake		Brake *
				0 mm stroke	increase per 100 mm stroke	
AB 25	OSP-P25	350	2.5	1.0	0.197	0.35
AB 32	OSP-P32	590	2.5	2.02	0.354	0.58
AB 40	OSP-P40	900	2.5	2.83	0.415	0.88
AB 50	OSP-P50	1400	2.5	5.03	0.566	1.50
AB 63	OSP-P63	2170	3.0	9.45	0.925	3.04
AB 80	OSP-P80	4000	3.0	18.28	1.262	5.82

Note:

For combinations Active Brake AB + SFI-plus + Magnetic Switch contact our technical department.

Active brake in combination with Basic Cylinder see page 123, pos.20

⁽¹⁾ –at 6 bar
 both chambers pressurised with 6 bar
 Braking surface dry
 –oil on the braking surface will reduce the braking force

*** Please Note:**
 The mass of the brake has to be added to the total moving mass when using the cushioning diagram.

Series OSP-P25 and P32 with Active Brake AB

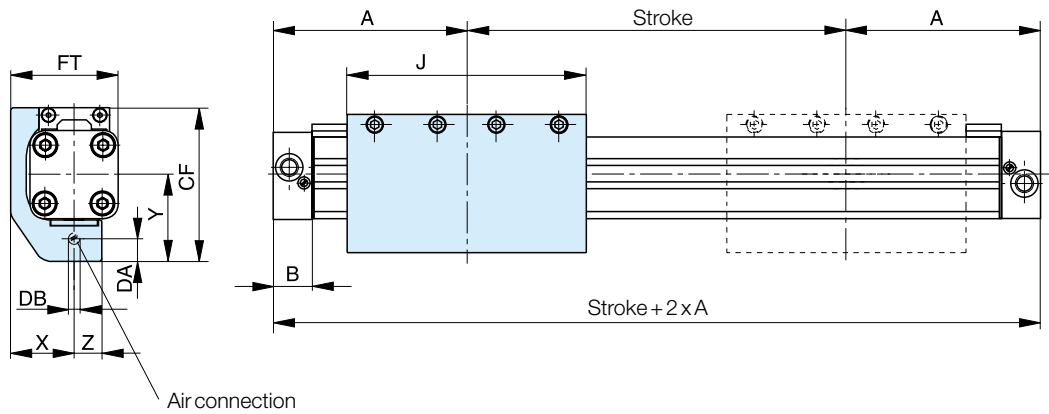

Series OSP-P40, P50, P63, P80 with Active Brake AB

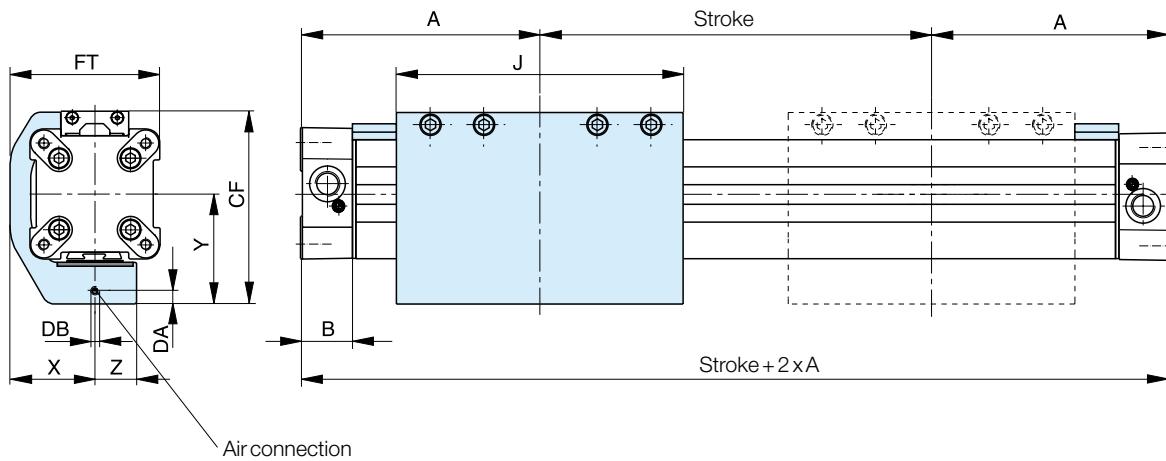

Dimension [mm]

Series	A	B	J	X	Y	Z	CF	DA	DB	FT
AB 25	100	22	117	29.5	43	13	74	4	M5	50
AB 32	125	25.5	151.4	36	50	15	88	4	M5	62
AB 40	150	28	151.4	45	58	22	102	7	M5	79.5
AB 50	175	33	200	54	69.5	23	118.5	7.5	M5	97.5
AB 63	215	38	256	67	88	28	151	9	G1/8	120
AB 80	260	47	348	83	105	32	185	10	G1/8	149

End Cap Mountings



On the end-face of each cylinder end cap there are four threaded holes for mounting the cylinder. The hole layout is square, so that the mounting can be fitted to the bottom, top or either side.

Material: Series OSP-P25, P32:
Galvanised steel

The mountings are supplied in pairs.

Series OSP – P25 and P32 with Active Brake AB: Type A3

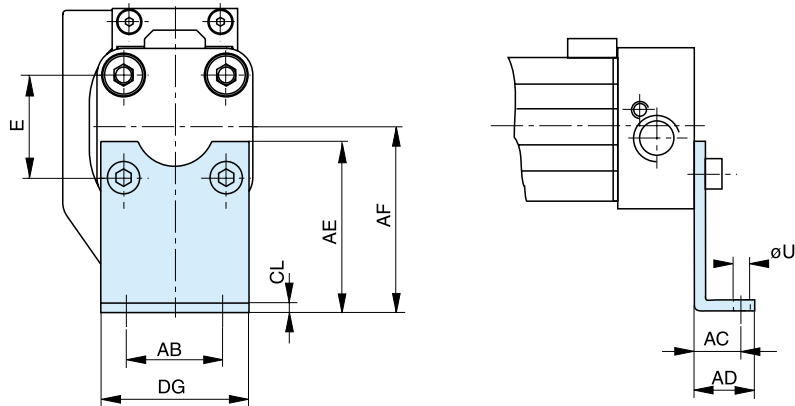

Series OSP – P40, P50, P63, P80 with Active Brake AB: Type C3



Material: Series OSP-
P40, P50, P63, P80:
Anodised aluminium

The mountings are supplied in pairs.

Stainless steel version on request.

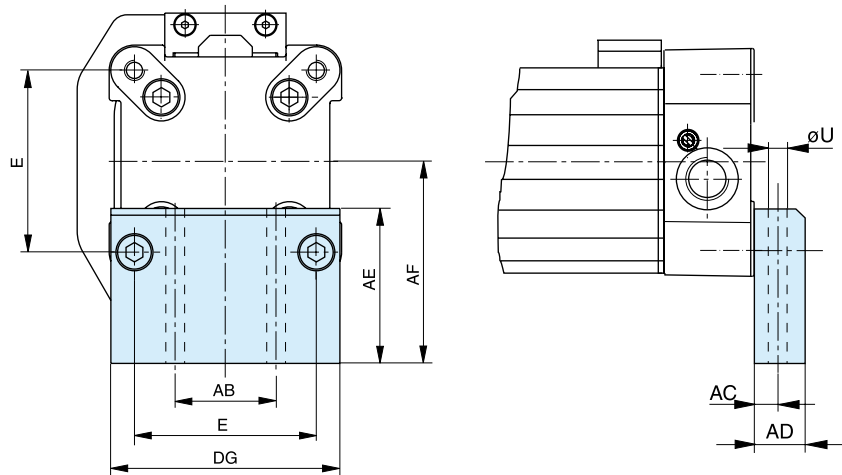

Dimension [mm]

Series	E	ØU	AB	AC	AD	AE	AF	CL	DG	Order No.	
										Type A3	Type C3
AB 25	27	5.8	27	16	22	45	49	2.5	39	2060FIL	-
AB 32	36	6.6	36	18	26	42	52	3	50	3060FIL	-
AB 40	54	9	30	12.5	24	46	60	-	68	-	20339FIL
AB 50	70	9	40	12.5	24	54	72	-	86	-	20350FIL
AB 63	78	11	48	15	30	76	93	-	104	-	20821FIL
AB 80	96	14	60	17.5	35	88	110	-	130	-	20822FIL

OSP-P Modular Pneumatic Linear Drive Systems

Mid-Section Supports

Mid-section supports are required from a certain stroke length to prevent excessive deflection and vibration of the linear drive.

The diagrams show the maximum permissible unsupported length in relation to loading. Deflection of 0.5 mm max. between supports is permissible.

The mid section supports are attached to the dovetail rails, and can take axial loads.

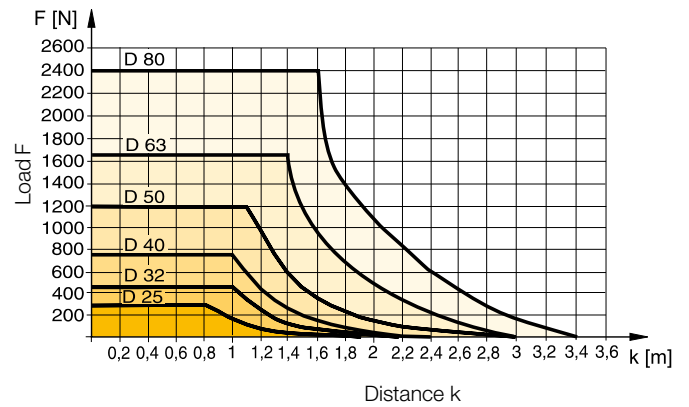
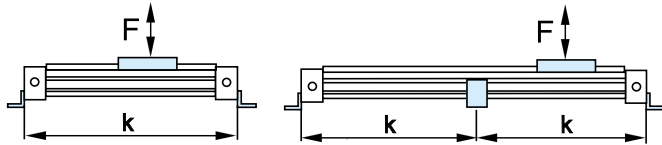

Series OSP-P25 to P80 with Active Brake AB: Type E3 - (Mounting from above / below with through-bolt)

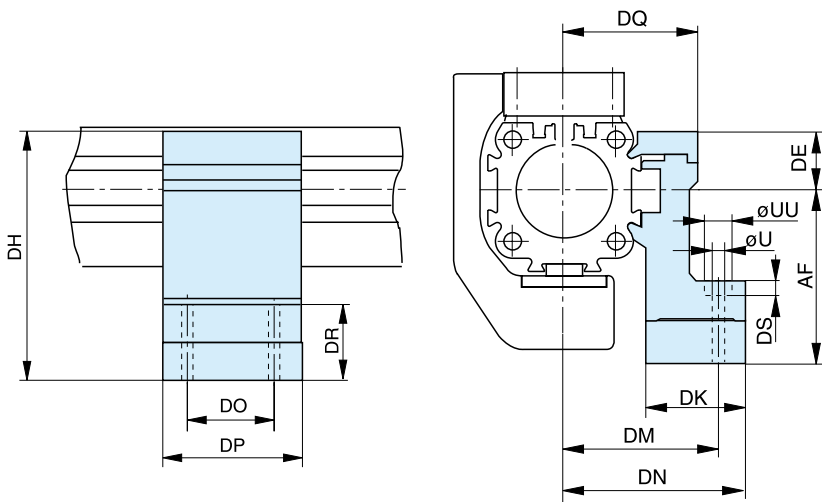

Note to Type E3:

Mid section supports can only be mounted opposite of the brake housing.

Stainless steel version available on request.

Series	U	UU	AF	DE	DH	DK	DM	DN	DO	DP	DQ	DR	DS	Order no. Type E3
AB 25	5.5	10	49	16	65	26	40	47.5	36	50	34.5	35	5.7	20353FIL
AB 32	5.5	10	52	16	68	27	46	54.5	36	50	40.5	32	5.7	20356FIL
AB 40	7	-	60	23	83	34	53	60	45	60	45	32	-	20359FIL
AB 50	7	-	72	23	95	34	59	67	45	60	52	31	-	20362FIL
AB 63	9	-	93	34	127	44	73	83	45	65	63	48	-	20453FIL
AB 80	11	-	110	39.5	149.5	63	97	112	55	80	81	53	-	20819FIL

Accessories for linear drives with Active Brakes – please order separately

Description	For details information, see:
Clevis mounting	Page 92
Adaptor profile	Page 105
T-groove profile	Page 106
Connection profile	Page 107
Magnetic switch (can only be mounted opposite of the brake housing)	Page 110
Incremental displacement measuring system SFI-plus	Page 118

Multi-Brake

Passive Brake

with plain bearing guide Slideline SL Series MB-SL 25 to 80 for Linear Drive

Features:

- Brake operated by spring actuation
- Brake release by pressurisation
- Anodised aluminium rail, with prism shaped slide elements
- Adjustable plastic slide elements
- Composite sealing system with plastic and felt wiper elements to remove dirt and lubricate the slideway
- Replenishable guide lubrication by integrated grease nipples
- Blocking function in case of pressure loss
- Intermediate stops possible

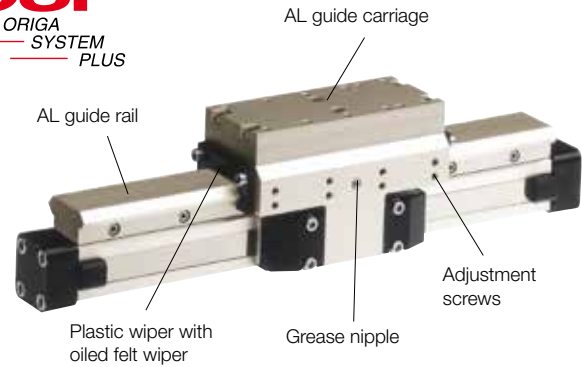

Function:

The Multi-Brake is a passive device. When the air pressure is removed the brake is actuated and movement of the cylinder is blocked. The brake is released by pressurisation. The high friction, wear resistant brake linings allow the Multi-Brake to be used as a dynamic brake to stop cylinder movement in the shortest possible time. The powerful springs also allow the Multi-Brake to be used effectively in positioning applications.

Loads, Forces and Moments

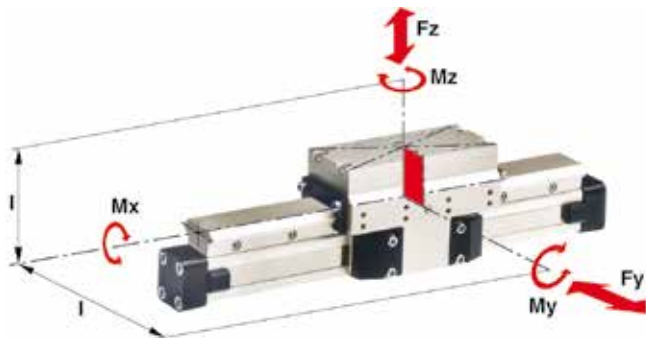

Function

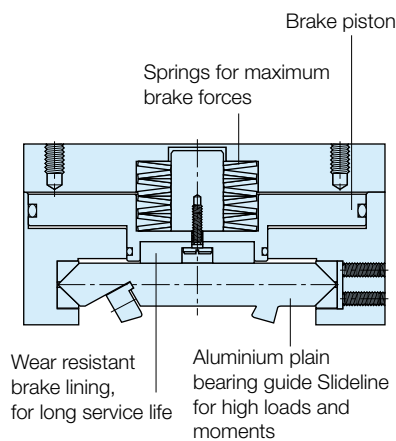

Technical Data

The table shows the maximum values for light, shock-free operation, which must not be exceeded even in dynamic operation.

Load and moment data are based on speeds $v < 0.2$ m/s.
Operating pressure 4.5 - 8 bar
A pressure of 4.5 bar is required to release the brake.

*** Please note:**

in the cushioning diagram, the mass of the guide carriage has to be added to the total moving mass.

¹⁾ Braking surface dry – oil on the braking surface will reduce the braking force

Series	For linear drive	Max. moments [Nm]			Max. loads [N] Fy, Fz	Max. brake force [N] ¹⁾	Mass of linear drive with guide [kg]		Mass ²⁾ guide carriage [kg]	Order-No. ** MB-SL Guide with passive brake without cylinder*
		Mx	My	Mz			with 0mm stroke	increase per 100mm stroke		
MB-SL 25	OSP-P25	14	34	34	675	470	2.04	0.39	1.10	20796
MB-SL 32	OSP-P32	29	60	60	925	790	3.82	0.65	1.79	20797
MB-SL 40	OSP-P40	50	110	110	1600	1200	5.16	0.78	2.34	20798
MB-SL 50	OSP-P50	77	180	180	2000	1870	8.29	0.97	3.63	20799
MB-SL 63	OSP-P63	120	260	260	2500	2900	13.31	1.47	4.97	20800
MB-SL 80	OSP-P80	120	260	260	2500	2900	17.36	1.81	4.97	20846

** Please use this order pattern: Order-No. + „stroke in mm“ (5 digits)
Example: MB-SL guide with passive brake D 25 mm, stroke 1000 mm: 20796-01000

MB-SL in combination with cylinder see page 123, pos. 20



Series OSP-P with Passive Brake MB-SL

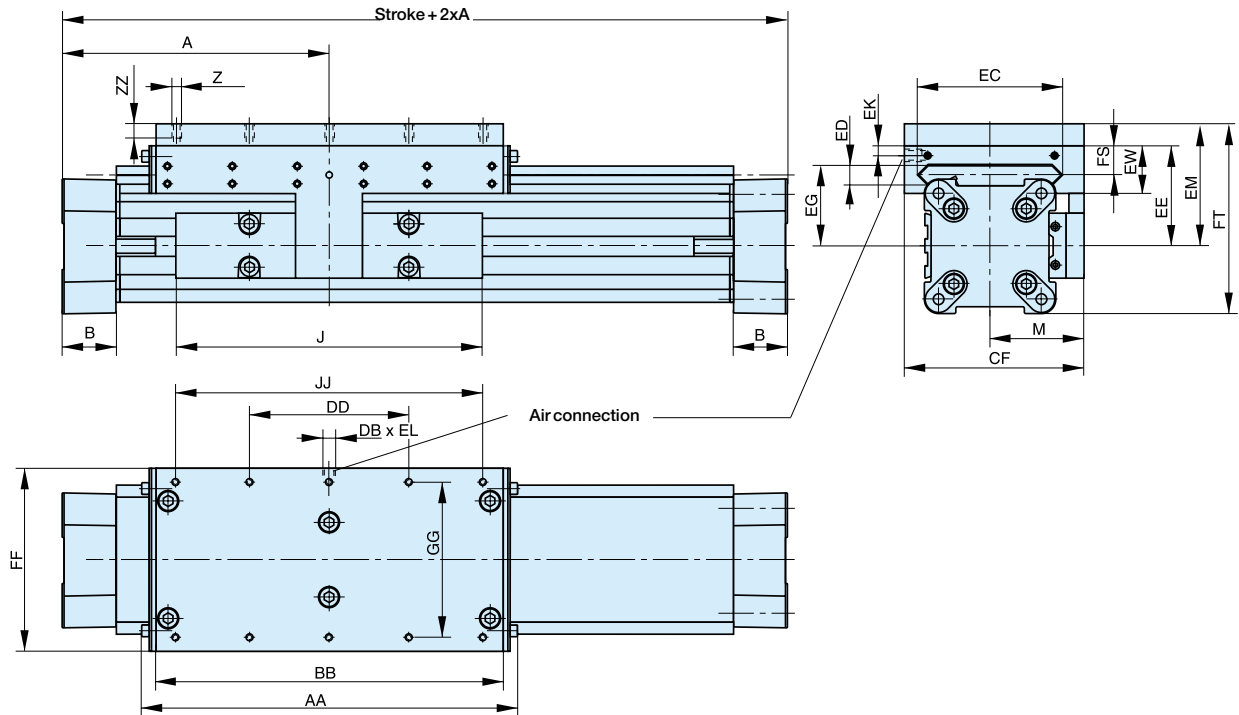

Dimension [mm]

Series	A	B	J	M	Z	AA	BB	DB	DD	CF	EC	ED	EE	EG	EK	EL	EM	EW	FF	FT	FS	GG	JJ	ZZ
MB-SL25	100	22	117	40,5	M6	162	142	M5	60	72.5	47	12	53	39	9	5	73	30	64	93.5	20	50	120	12
MB-SL32	125	25.5	152	49	M6	205	185	G1/8	80	91	67	14	62	48	7	10	82	33	84	108	21	64	160	12
MB-SL40	150	28	152	55	M6	240	220	G1/8	100	102	77	14	64	50	6.5	10	84	34	94	118.5	21.5	78	200	12
MB-SL50	175	33	200	62	M6	284	264	G1/8	120	117	94	14	75	56	10	12	95	39	110	138.5	26	90	240	12
MB-SL63	215	38	256	79	M8	312	292	G1/8	130	152	116	18	86	66	11	12	106	46	152	159	29	120	260	13
MB-SL80	260	47	348	96	M8	312	292	G1/8	130	169	116	18	99	79	11	12	119	46	152	185	29	120	260	13

Mid-Section Support

Mid section supports are required from a certain stroke length to prevent excessive deflection and vibration of the linear drive. The diagrams show the maximum permissible unsupported length in relation to loading. A distinction must be drawn between loading 1 and loading 2. Deflection of 0.5 mm max. between supports is permissible.

Note

For speeds $v > 0.5$ m/s the distance between supports should not exceed 1m.

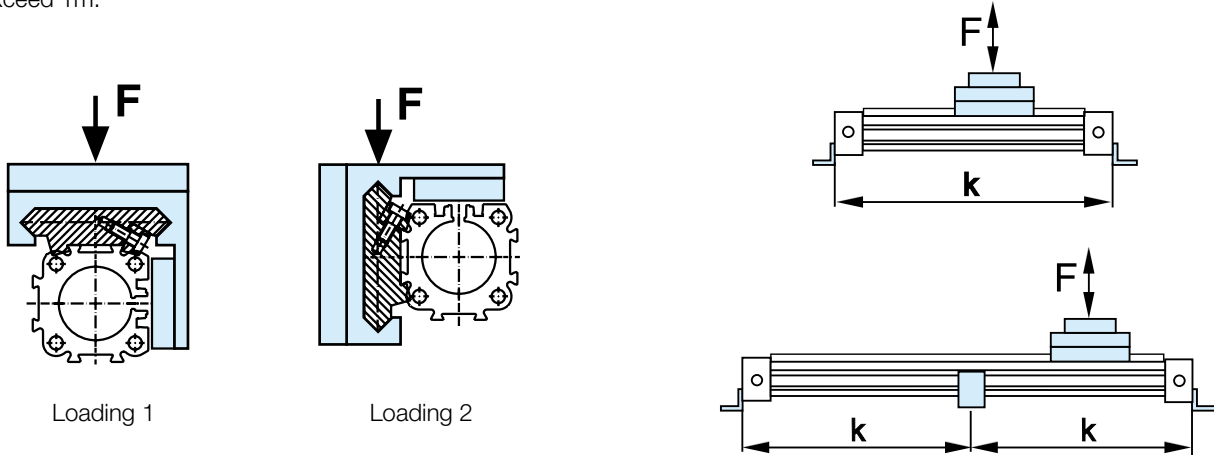

Permissible Unsupported Length MB-SL25, MB-SL32

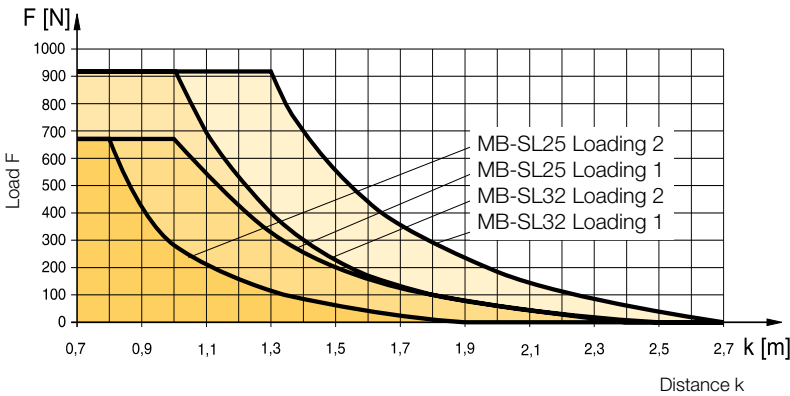

Permissible Unsupported Length MB-SL40, MB-SL50, MB-SL63 and MB-SL80

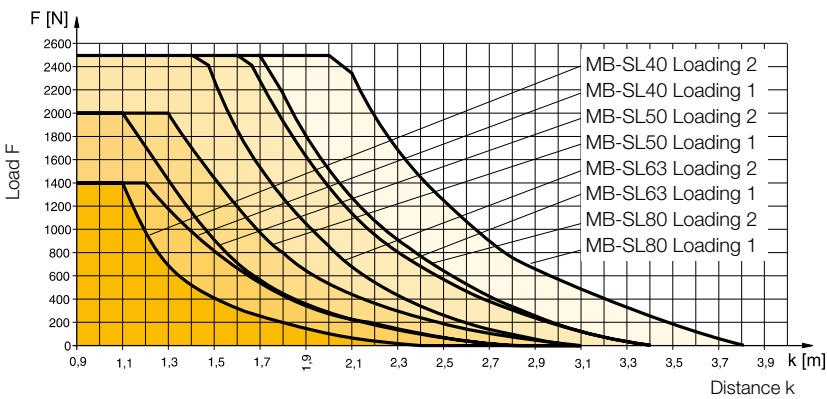

Multi-Brake

Passive Brake

with Aluminium Roller Guide Proline PL Series MB-PL 25 to 50 for Linear Drive

Features:

- Brake operated by spring actuation
- Brake release by pressurisation
- Composite sealing system with plastic and felt wiper elements to remove dirt and lubricate the slideway
- Blocking function in case of pressure loss
- Intermediate stops possible

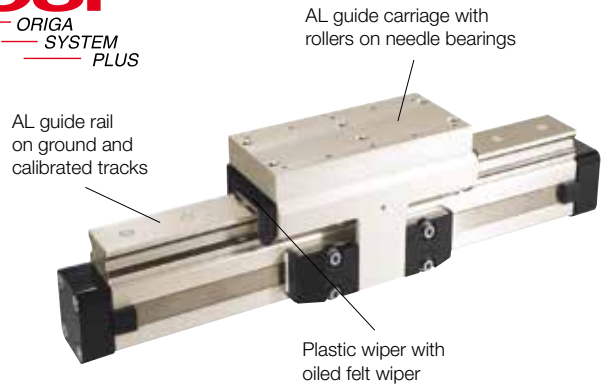

Function:

The Multi-Brake is a passive device. When the air pressure is removed the brake is actuated and movement of the cylinder is blocked. The brake is released by pressurisation. The high friction, wear resistant brake linings allow the Multi-Brake to be used as a dynamic brake to stop cylinder movement in the shortest possible time. The powerful springs also allow the Multi-Brake to be used effectively in positioning applications.

Loads, Forces and Moments

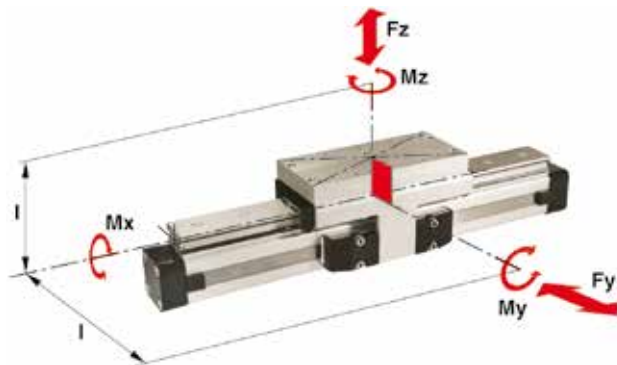

Technical Data

The table shows the maximal permissible loads. If multiple moments and forces act upon the cylinder simultaneously, the following equation applies:

$$\frac{M_x}{M_{x_{max}}} + \frac{M_y}{M_{y_{max}}} + \frac{M_z}{M_{z_{max}}} + \frac{F_y}{F_{y_{max}}} + \frac{F_z}{F_{z_{max}}} \leq 1$$

The sum of the loads should not exceed >1. With a load factor of less than 1, service life is 8000 km

Function

Wear resistant brake lining, for long service life
 Springs for maximum brake forces

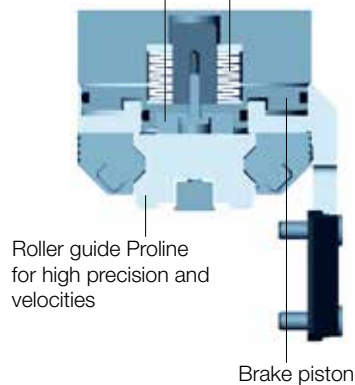

The table shows the maximum permissible values for light, shock-free operation, which must not be exceeded even under dynamic conditions.

Operating Pressure 4.5 - 8 bar. A pressure of min. 4.5 bar release the brake.

Series	For linear drive	Max. moments [Nm]			Max. loads [N]	Max. brake force [N] ¹⁾	Mass of linear drive with guide [kg]		Mass ²⁾ guide carriage [kg]	Order-No.** MB-PL Guide with passive brake without cylinder*
		Mx	My	Mz			Fy, Fz	with 0 mm stroke		
MB-PL25	OSP-P25	16	39	39	857	315	2.14	0.40	1.24	20864
MB-PL32	OSP-P32	29	73	73	1171	490	4.08	0.62	2.02	20865
MB-PL40	OSP-P40	57	158	158	2074	715	5.46	0.70	2.82	20866
MB-PL50	OSP-P50	111	249	249	3111	1100	8.60	0.95	4.07	20867

** Please use this order pattern: Order-No. + „stroke in mm“ (5 digits)
 Example: MB-PL guide with passive brake, D25 mm, stroke 1000 mm: 20864-01000

MB-PL in combination with cylinder see page 123, pos. 20



Series OSP-P with Passive Brake MB-PL

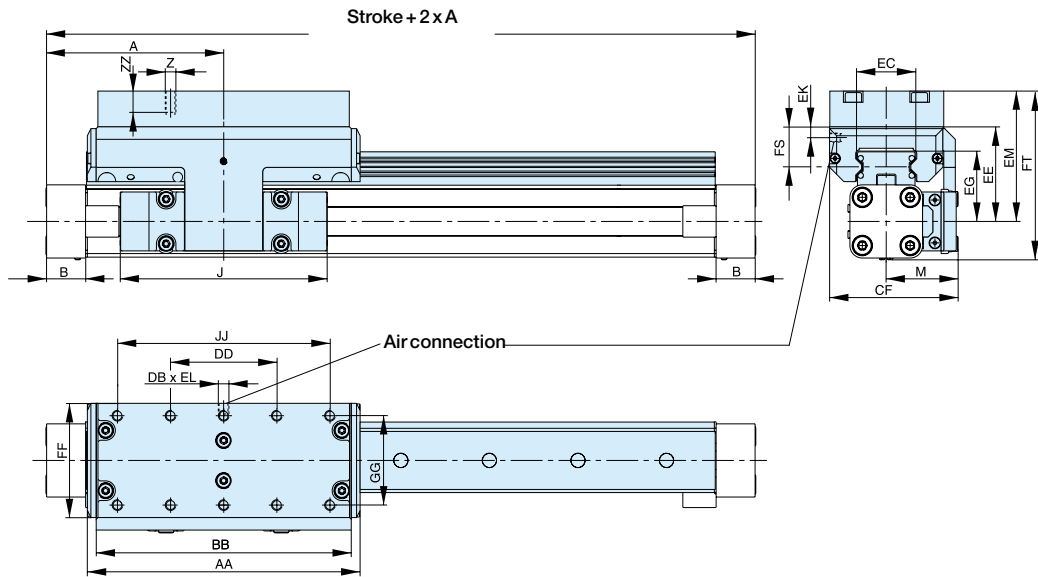

Dimensions [mm] Series OSP-P MB-PL25, MB-PL32, MB-PL40, MB-PL50

Series	A	B	J	M	Z	AA	BB	DB	DD	CF	EC	EE	EG	EK	EL	EM	FF	FS	FT	GG	JJ	ZZ
MB-PL25	100	22	117	40.5	M6	154	144	M5	60	72.5	32.5	53	39	9	5	73	64	23	93.5	50	120	12
MB-PL32	125	25.5	152	49	M6	197	187	G1/8	80	91	42	62	48	7	10	82	84	25	108	64	160	12
MB-PL40	150	28	152	55	M6	232	222	G1/8	100	102	47	64	50.5	6.5	10	84	94	23.5	118.5	78	200	12
MB-PL50	175	33	200	62	M6	276	266	G1/8	120	117	63	75	57	10	12	95	110	29	138.5	90	240	16

Mid-Section Support

Mid section supports are required from a certain stroke length to prevent excessive deflection and vibration of the linear drive. The diagrams show the maximum permissible unsupported length in relation to loading. A distinction must be drawn between loading 1 and loading 2. Deflection of 0.5 mm max. between supports is permissible.

Note:

For speeds $v > 0.5$ m/s the distance between supports should not exceed 1 m.

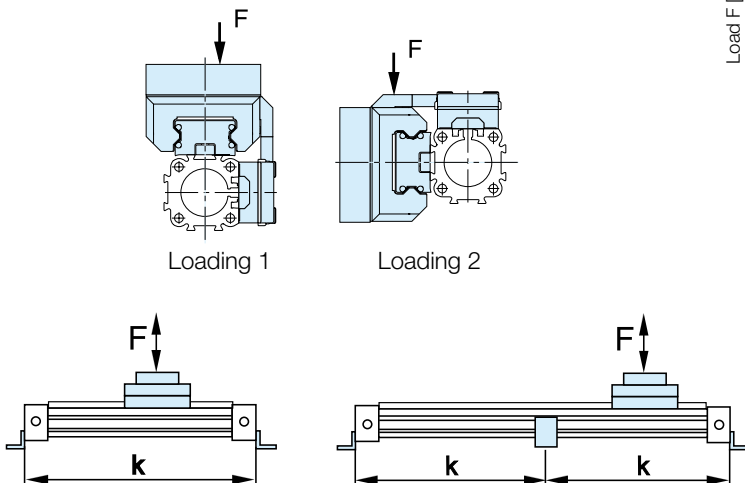

Permissible Unsupported Length OSP-P MB-PL25, MB-PL32, MB-PL40, MB-PL50

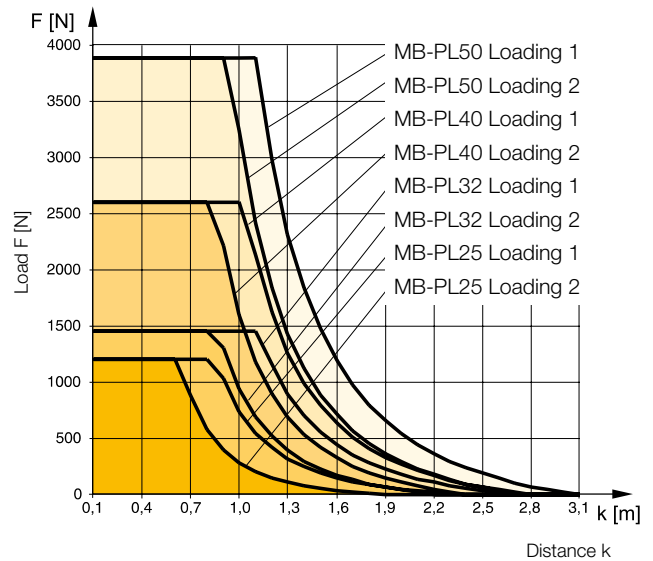

Application Example - Vertical Application

Control of a cylinder with 3/2 way valves. Basic position – **exhausted**

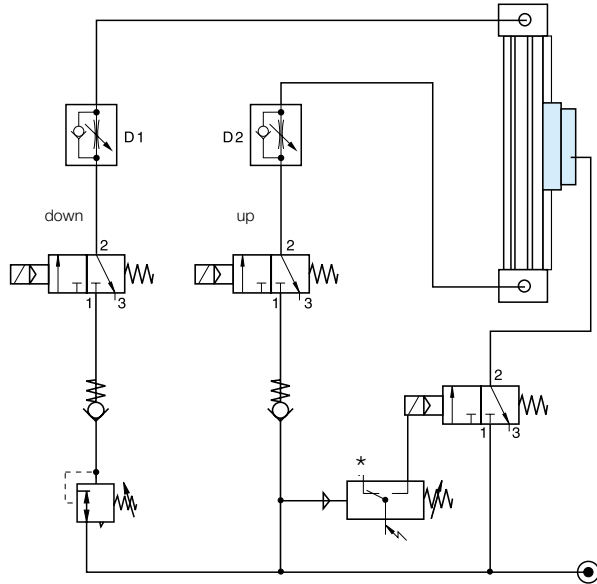

Control of a cylinder with 3/2 way valves. Basic position – **pressurised**

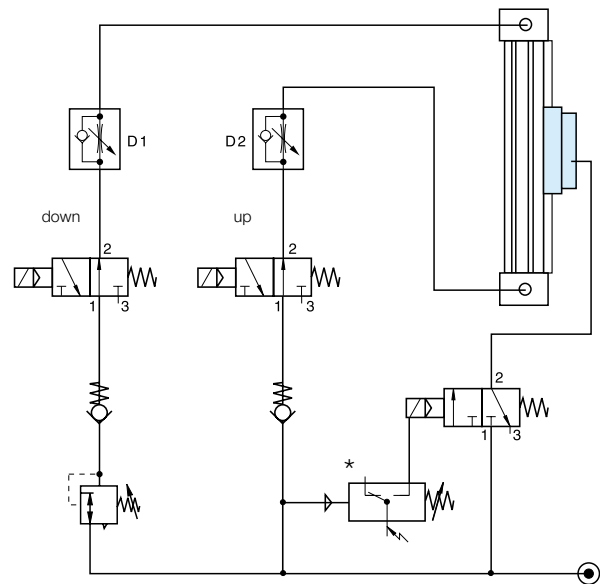

Control Examples

Under normal operating circumstances the pressure switch is closed and the air flows through the 3/2 way solenoid valves from port 1 to 2, thus lifting the brake from the rail (operating condition). The brake is pressurised by means of a 3/2 way valve in combination with a pressure switch. When there is a pressure loss, the brake is actuated by the pressure switch. When the air pressure is restored to both cylinder chambers, the brake is lifted and the linear drive can be moved again.

The speed regulating valves D1 and D2 control the speed of the linear drive, and have no influence on the brake. The two non-return valves give the system a higher stability. The pressure regulating valve is used to compensate for the downward force in this vertical application.

















Please note:
Before the brake is lifted, make sure that both air chambers of the linear drive are pressurised.
Small diameter tubing, fittings and valves with a nominal diameter, and tubing that is too long all change the reaction time of the brake!

*** Tip:**
 The pressure switch actuates the brake when the pressure drops below the set value.

Linear Drive Accessories for Series OSP-P

Description

Clevis Mounting		Page 91 - 92
End Cap Mountings		Page 93
End Cap Mountings (for Linear Drives with guides)		From page 95
Mid-Section Support		Page 94
Mid-Section Support (for Linear Drives with guides)		From page 95
Inversion Mounting		Page 104
Adaptor Profile		Page 105
T-Slot Profile		Page 106
Connection Profile		Page 107
Dulex Connection		Page 108
Multiplex Connection		Page 109
Magnetic Switch for T-Nut mounting P8S-G		Page 110
Magnetic Switch, ATEX-version 		Page 114
Cable cover		Page 117

Ø 10mm Clevis Mounting

When external guides are used, parallelism deviations can lead to mechanical strain on the piston. This can be avoided by the use of a clevis mounting.

In the drive direction, the mounting has very little play. Freedom of movement is provided as follows:

- Tilting in direction of movement
- Vertical compensation
- Tilting sideways
- Horizontal compensation



Series OSP-P10

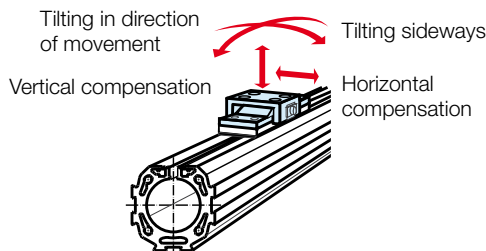
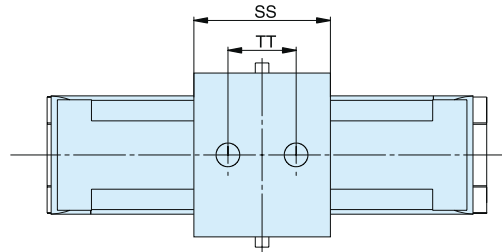
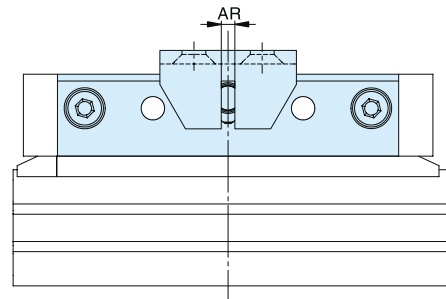
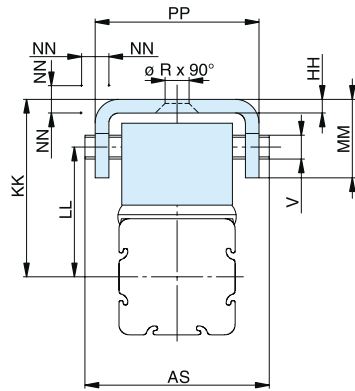

Order instructions in combination with basic cylinder see page 25, pos. 19

Dimensions [mm]

For series	ØR	V	AR	AS	HH	KK	LL	MM	NN*	PP	SS	TT	Order No.	
													Standard	Stainless
OSP-P10	3.4	3.5	2	27	2	26	19	11.5	1	24	20	10	20971FIL	-

* Dimension NN gives the possible plus and minus play in horizontal and vertical movement, which also makes tilting sideways possible.

For rodless pneumatic cylinder OSP-P overview see page 5

Ø 16 - 80 mm Clevis Mounting

When external guides are used, parallelism deviations can lead to mechanical strain on the piston. This can be avoided by the use of a clevis mounting.

In the drive direction, the mounting has very little play. Freedom of movement is provided as follows:

- Tilting in direction of movement
- Vertical compensation
- Tilting sideways
- Horizontal compensation

A stainless steel version is also available.



Series OSP-P16 to 32

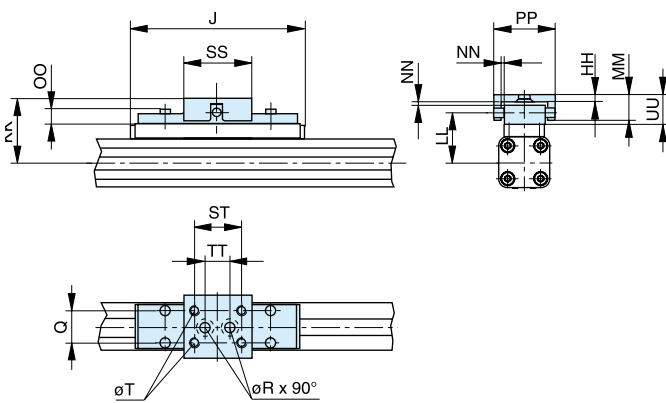

Series OSP-P40 to 80

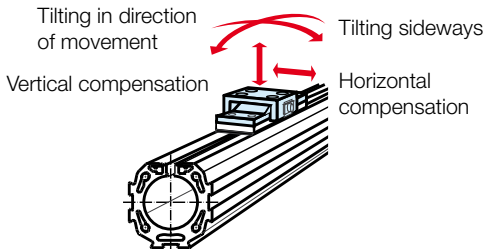
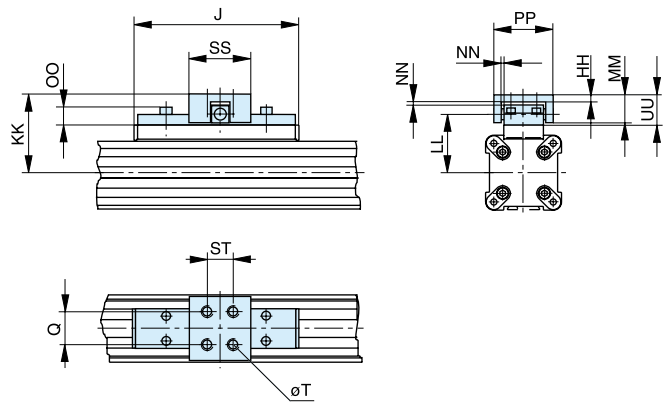

Please note:

When using additional inversion mountings, take into account the dimensions on page 104.

Order instructions in combination with basic cylinder see page 25, pos. 19

Dimensions [mm]

For series	J	Q	T	ØR	HH	KK	LL	MM	NN*	OO	PP	SS	ST	TT	UU	Order No.	
																Standard	Stainless
OSP-P16	69	10	M4	4.5	3	34	26.6	10	1	8.5	26	28	20	10	11	20462FIL	20463FIL
OSP-P25	117	16	M5	5.5	3.5	52	39	19	2	9	38	40	30	16	21	20005FIL	20092FIL
OSP-P32	152	25	M6	6.6	6	68	50	28	2	13	62	60	46	40	30	20096FIL	20094FIL
OSP-P40	152	25	M6	-	6	74	56	28	2	13	62	60	46	-	30	20024FIL	20093FIL
OSP-P50	200	25	M6	-	6	79	61	28	2	13	62	60	46	-	30	20097FIL	20095FIL
OSP-P63	256	37	M8	-	8	100	76	34	3	17	80	80	65	-	37	20466FIL	20467FIL
OSP-P80	348	38	M10	-	8	122	96	42	3	16	88	90	70	-	42	20477FIL	20478FIL

* Dimension NN gives the possible plus and minus play in horizontal and vertical movement, which also makes tilting sideways possible.

For rodless pneumatic cylinder OSP-P overview see page 5



Ø 10 - 80 mm End Cap Mountings

On the end-face of each end cap there are four threaded holes for mounting the actuator.

The hole layout is square, so that the mounting can be fitted to the bottom, top or either side, regardless of the position chosen for the air connection.

Material:

Series OSP-P10 – P32: Galvanised steel.

Series OSP-P40 – P80: Anodized aluminium.

The mountings are supplied in pairs.



Series OSP-P10: Type A1

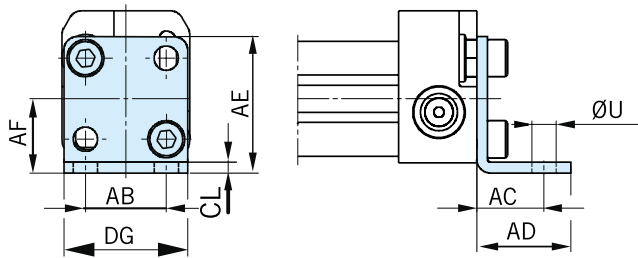

Series OSP-P16 to 32: Type A1

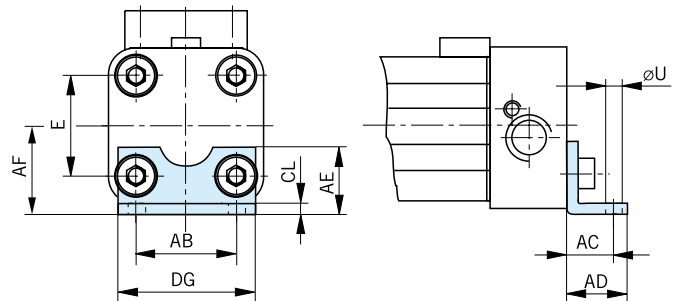

Series OSP-P40 to 80: Type C1

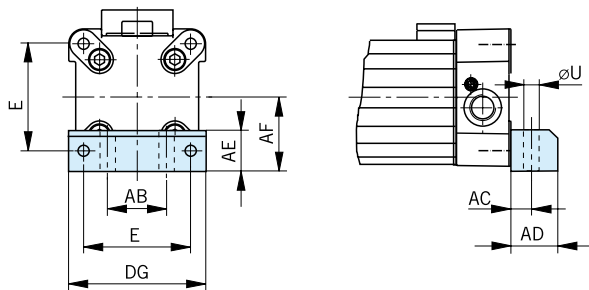

Dimensions [mm]

For series	E	ØU	AB	AC	AD	AE	AF	CL	DG	Order-No. (*	
										Type A1	Type C1
OSP-P10	-	3.6	12	10	14	20.2	11	1.6	18.4	0240FIL	-
OSP-P16	18	3.6	18	10	14	12.5	15	1.6	26	20408FIL	-
OSP-P25	27	5.8	27	16	22	18	22	2.5	39	2010FIL	-
OSP-P32	36	6.6	36	18	26	20	30	3	50	3010FIL	-
OSP-P40	54	9	30	12.5	24	24	38	-	68	-	4010FIL
OSP-P50	70	9	40	12.5	24	30	48	-	86	-	5010FIL
OSP-P63	78	11	48	15	30	40	57	-	104	-	6010FIL
OSP-P80	96	14	60	17.5	35	50	72	-	130	-	8010FIL

(* = Pair)

For rodless pneumatic cylinder OSP-P overview see page 5



Ø 10 - 80 mm Mid Section Support

Note on Types E1 and D1
(P16 – P80):

The mid-section support can also be mounted on the underside of the actuator, in which case its distance from the centre of the actuator is different.

Stainless steel version on request.



Series OSP-P10: Type E1

(Mounting from above / below using a cap screw)

Series OSP-P16 to 80: Type E1

(Mounting from above / below using a cap screw)

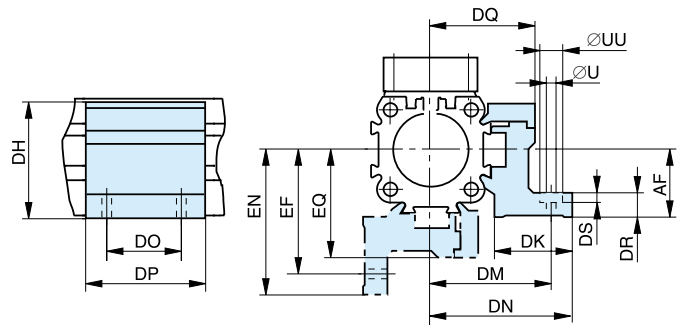
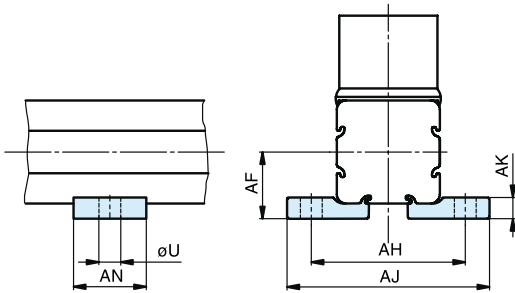

Series OSP-P16 to 80: Type D1

(Mounting from below with 2 screws)

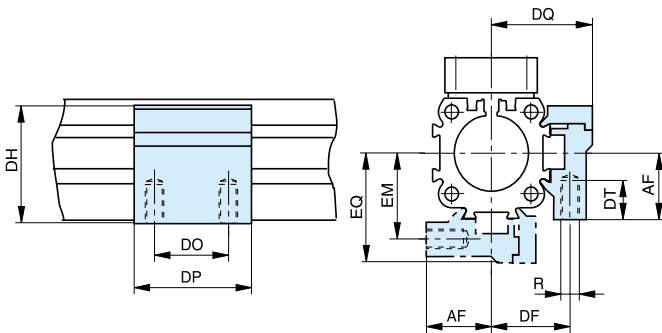

Dimensions [mm] - Series OSP-P10

For series	U	AF	AH	AJ	AK	AN	Order No.	
							Type E1	Type D1
OSP-P10	3.6	11	25.4	33.4	3.5	12	0250FIL	-

Dimensions [mm]

For series	R	U	UU	AF	DF	DH	DK	DM	DN	DO	DP	DQ	DR	DS	DT	EF	EM	EN	EQ	Order No.	
																				Type E1	Type D1
OSP-P16	M3	3.4	6	15	20	29.2	24	32	36.4	18	30	27	6	3.4	6.5	32	20	36.4	27	20435FIL	20434FIL
OSP-P25	M5	5.5	10	22	27	38	26	40	47.5	36	50	34.5	8	5.7	10	41.5	28.5	49	36	20009FIL	20008FIL
OSP-P32	M5	5.5	10	30	33	46	27	46	54.5	36	50	40.5	10	5.7	10	48.5	35.5	57	43	20158FIL	20157FIL
OSP-P40	M6	7	-	38	35	61	34	53	60	45	60	45	10	-	11	56	38	63	48	20028FIL	20027FIL
OSP-P50	M6	7	-	48	40	71	34	59	67	45	60	52	10	-	11	64	45	72	57	20163FIL	20162FIL
OSP-P63	M8	9	-	57	47.5	91	44	73	83	45	65	63	12	-	16	79	53.5	89	69	20452FIL	20451FIL
OSP-P80	M10	11	-	72	60	111.5	63	97	112	55	80	81	15	-	25	103	66	118	87	20482FIL	20480FIL



For rodless pneumatic cylinder OSP-P overview see page 5



Mountings for Linear Drives fitted with OSP-Guides

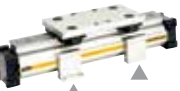

Overview

Mounting Type	Type	Type - OSP Guides																
		SLIDELINE PROLINE MULTIBRAKE								POWERSLIDE								
		16 ¹⁾	25	32	40	50	63 ¹⁾	80 ¹⁾	16/25	25/25	25/35	25/44	32/35	32/44	40/44	40/60	50/60	50/76
End cap mounting 	Type A1	X							X									
	Type A2	O	O	O														
	Type A3									O	O		O					
End cap mounting reinforced 	Type B1		X	X						X	X	X	X	X				
	Type B3								O									
	Type B4											O		O				
	Type B5																	
End cap mounting 	Type C1				X	X	X	X							X	X	X	X
	Type C2				O	O												
	Type C3						O	O							O		O	
	Type C4															O		O
Mid section support, small Mid section support, wide 	Type D1	X	X	X	X	X	X	X	X	X	X	X	X	X	X	X	X	X
	Type E1	X	X	X	X	X	X	X	X	X	X	X	X	X	X	X	X	X
	Type E2	O	O	O	O	O												
	Type E3						O	O	O	O	O		O		O		O	
	Type E4											O		O		O		O
	Type E5																	

- X = carriage mounted in top (12 o'clock position)
- O = carriage mounted in lateral (3 or 9 o'clock position)
- = available components
- ¹⁾ = not available for all sizes

Note:
 For mountings and mid-section supports for linear drives with recirculating ball bearing guide STARLINE, for recirculating ball bearing guide KF, see page 98 to 103.

End Cap Mountings *

Four internal screw threads are located in the end faces of all OSP actuators for mounting the drive unit. End cap mountings may be secured across any two adjacent screws.

Material:

Series OSP-16, 25, 32: Galvanised steel.

Series OSP-40,50, 63, 80: Anodized aluminium.

The mountings are supplied in pairs.



Series OSP-P16, 25, 32: Type A

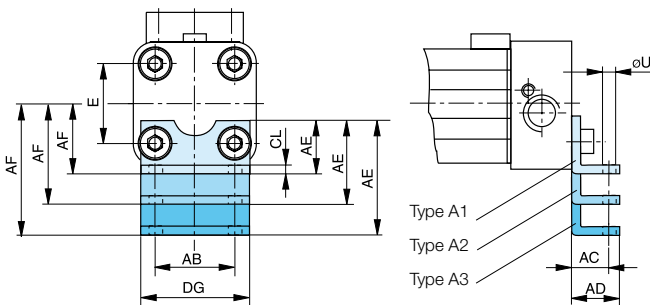

Series OSP-P16, 25, 32: Type B

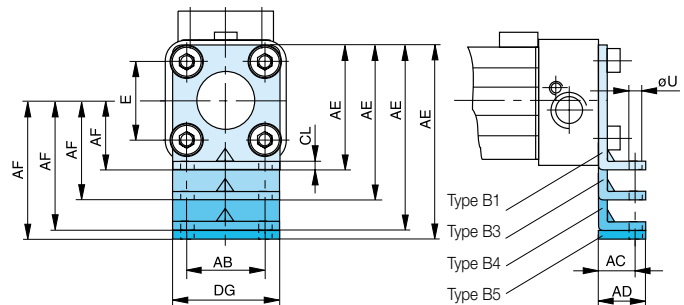

Series OSP-P40, 50, 63, 80: Type C

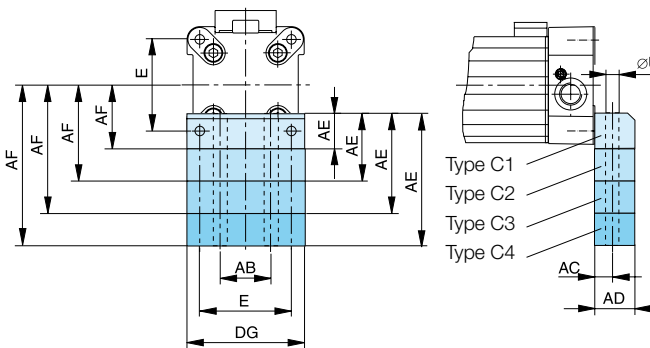

Dimensions [mm]

Dimensions AE and AF (Dependant on the mounting type)

Mount. type	Dimensions AE for size							Dimensions AF for size						
	16	25	32	40	50	63	80	16	25	32	40	50	63	80
A1	12.5	18	20	-	-	-	-	15	22	30	-	-	-	-
A2	27.5	33	34	-	-	-	-	30	37	44	-	-	-	-
A3	-	45	42	-	-	-	-	-	49	52	-	-	-	-
B1	-	42	55	-	-	-	-	-	22	30	-	-	-	-
B3	55	-	-	-	-	-	-	42	-	-	-	-	-	-
B4	-	80	85	-	-	-	-	-	60	60	-	-	-	-
B5	-	-	90	-	-	-	-	-	-	65	-	-	-	-
C1	-	-	-	24	30	40	50	-	-	-	38	48	57	72
C2	-	-	-	37	39	-	-	-	-	-	51	57	-	-
C3	-	-	-	46	54	76	88	-	-	-	60	72	93	110
C4	-	-	-	56	77	-	-	-	-	-	70	95	-	-

Dimensions [mm]

For series	E	ØU	AB	AC	AD	CL	DG
OSP-P16	18	3.6	18	10	14	1.6	26
OSP-P25	27	5.8	27	16	22	2.5	39
OSP-P32	36	6.6	36	18	26	3	50
OSP-P40	54	9	30	12.5	24	-	68
OSP-P50	70	9	40	12.5	24	-	86
OSP-P63	78	11	48	15	30	-	104
OSP-P80	96	14	60	17.5	35	-	130

* see mounting instructions on page 95



Mid Section Support

Information regarding type E1 and D1:

Mounting of the mid section supports is also possible on the lower side of the drive. In this case, please note the new centre line dimensions.

Stainless steel version on request.



Series OSP-P16 to 80: Type E

(Mounting from above / below using a cap screw)

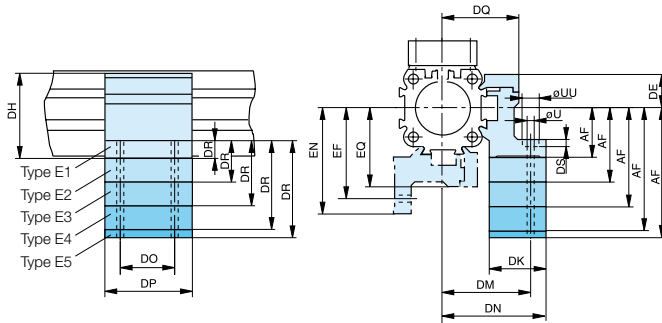

Series OSP-P16 to 80: Type D1

(Mounting from below with thread screw)

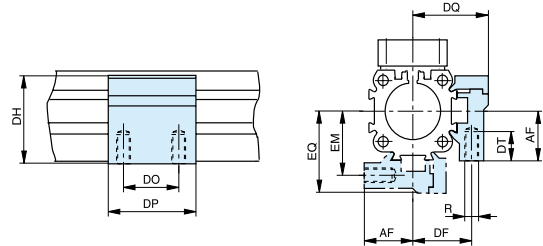

Dimensions [mm]

Dimensions AF and DR (Dependant on the mounting type)

Mount. type	Dimensions DR for size							Dimensions AF for size						
	16	25	32	40	50	63	80	16	25	32	40	50	63	80
D1	-	-	-	-	-	-	-	15	22	30	38	48	57	72
E1	6	8	10	10	10	12	15	15	22	30	38	48	57	72
E2	21	23	24	23	19	-	-	30	37	44	51	57	-	-
E3	33	35	32	32	34	48	53	42	49	52	60	72	93	110
E4	-	46	40	42	57	-	-	-	60	60	70	95	-	-
E5	-	-	45	-	-	-	-	-	-	65	-	-	-	-

Dimensions [mm]

For series	R	U	UU	DE	DF	DH	DK	DM	DN	DO	DP	DQ	DS	DT	EF	EM	EN	EQ
OSP-P16	M3	3.4	6	14.2	20	29.2	24	32	36.4	18	30	27	3.4	6.5	32	20	36.4	27
OSP-P25	M5	5.5	10	16	27	38	26	40	47.5	36	50	34.5	5.7	10	41.5	28.5	49	36
OSP-P32	M5	5.5	10	16	33	46	27	46	54.5	36	50	40.5	5.7	10	48.5	35.5	57	43
OSP-P40	M6	7	-	23	35	61	34	53	60	45	60	45	-	11	56	38	63	48
OSP-P50	M6	7	-	23	40	71	34	59	67	45	60	52	-	11	64	45	72	57
OSP-P63	M8	9	-	34	47.5	91	44	73	83	45	65	63	-	16	79	53.5	89	69
OSP-P80	M10	11	-	39.5	60	111.5	63	97	112	55	80	81	-	25	103	66	118	87

Ordering information for mountings Type A – Type B – Type C – Type D – Type E

(* Pair)

Mounting type (versions)	Order No. size						
	16	25	32	40	50	63	80
A1 *)	20408FIL	2010FIL	3010FIL	-	-	-	-
A2 *)	20464FIL	2040FIL	3040FIL	-	-	-	-
A3 *)	-	2060FIL	3060FIL	-	-	-	-
B1 *)	-	20311FIL	20313FIL	-	-	-	-
B3 *)	20465FIL	-	-	-	-	-	-
B4 *)	-	20312FIL	20314FIL	-	-	-	-
B5 *)	-	-	20976FIL	-	-	-	-
C1 *)	-	-	-	4010FIL	5010FIL	6010FIL	8010FIL
C2 *)	-	-	-	20338FIL	20349FIL	-	-
C3 *)	-	-	-	20339FIL	20350FIL	20821FIL	20822FIL
C4 *)	-	-	-	20340FIL	20351FIL	-	-
D1	20434FIL	20008FIL	20157FIL	20027FIL	20162FIL	20451FIL	20480FIL
E1	20435FIL	20009FIL	20158FIL	20028FIL	20163FIL	20452FIL	20482FIL
E2	20436FIL	20352FIL	20355FIL	20358FIL	20361FIL	-	-
E3	20437FIL	20353FIL	20356FIL	20359FIL	20362FIL	20453FIL	20819FIL
E4	-	20354FIL	20357FIL	20360FIL	20363FIL	-	-
E5	-	-	20977FIL	-	-	-	-



Ø 25 - 50 mm End Cap Mounting

correspond to FESTO dimensions HP25 – 50

for Linear Drives with Recirculating Ball Bearing Guide

- Series OSP-P KF

On the end-face of each end cap there are four threaded holes for mounting the actuator.

Material:

Series OSP-P KF25 – 50: Anodized aluminium.

The mountings are supplied in pairs.

Series OSP-P KF25 to KF50: Type HP (Correspond to FESTO dimensions)

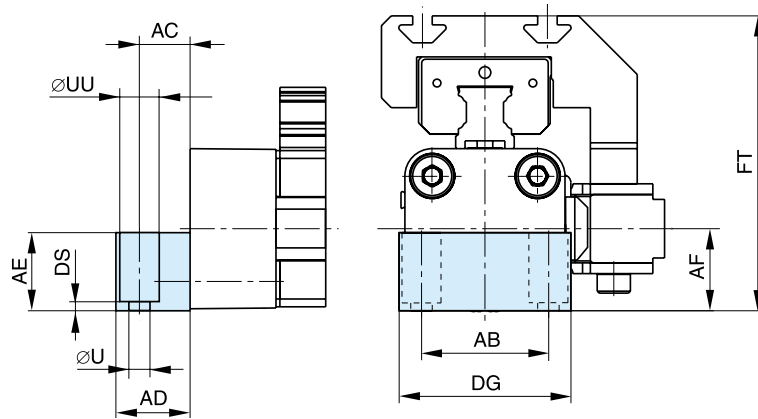

Note:

Correspond to FESTO DGPL-KF, when the End Cap Mountings HP are mounted on the opposite side to the carriage (see drawing)

Dimensions [mm]

Series	ØU	AB	AC	AD	AE	AF	DG	DS	FT	ØUU	Order No.
HP25	5.5	32.5	13	19	20	21	44	2	75.5	10	21107FIL
HP32	6.6	38	17	24	24	27	52	3	87.5	11	21108FIL
HP40	6.6	45	17.5	24	24	35	68	2	104.5	11	21109FIL
HP50	9	65	25	35	35	48	86	6	138.5	15	21110FIL

Ø 25 - 50 mm Mid Section Support

correspond to FESTO dimensions MUP25-50

for Linear Drives with Recirculating Ball Bearing Guide

- Series OSP-P KF

Series OSP-P KF25: Type MUP

(Mounting over through holes)

Series OSP-P KF32 to KF40: Type MUP

(Mounting over through holes)

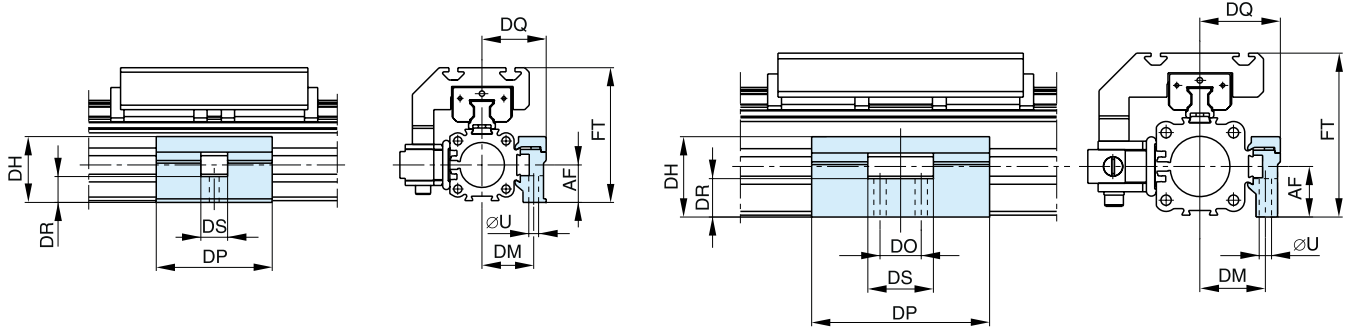

Series OSP-P KF50: Type MUP

(Mounting over through holes)

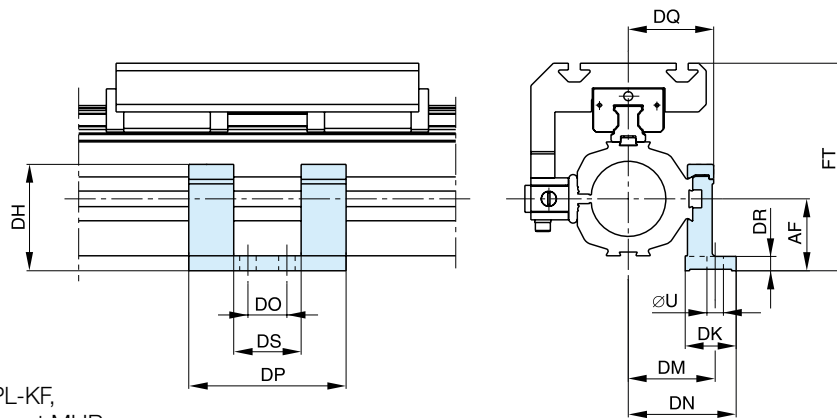

Note:

Correspond to FESTO DGPL-KF, when the Mid-Section Support MUP are mounted on the 90° side to the carriage (see drawings).

Dimensions [mm]

Series	ØU	AF	DH	DK	DM	DN	DO	DP	DQ	DR	DS	FT	Order No.
MUP25	5.5	21	36.9	-	29	-	-	65	36	14.5	15	75.5	21119FIL
MUP32	6.6	27	42.9	-	35	-	22	95	43	20.5	35	87.5	21120FIL
MUP40	6.6	35	58	-	40	-	22	95	48	28.5	35	104.5	21121FIL
MUP50	11	48	71	34	58	72	26	105	57	10	45	138.5	21122FIL

Ø 16 - 32 mm End Cap Mounting

Type : B

for Linear Drives with Recirculating Ball Bearing Guide

- Series OSP-P STL
- Series OSP-P KF

Material:

Galvanized steel
Anodized aluminium.

The mountings are supplied in pairs.



Series OSP-P STL16, STL25, STL32 : Type B1
Series OSP-P KF16, KF25, KF32: Type B1

Installation:

Top carrier
Side piston

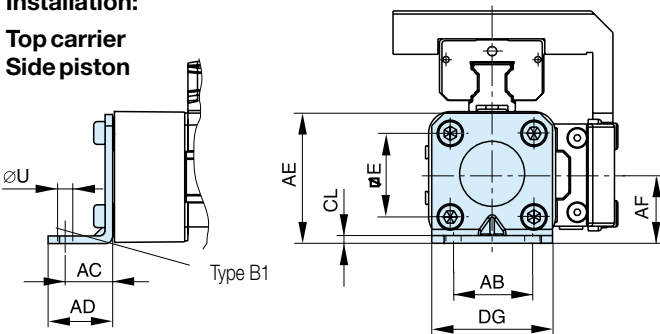

Drawing shows: Mounting with Guide Type STL

Series OSP-P STL16, STL25, STL32: Type B3 (Ø 32:B5)
Series OSP-P KF16, KF25, KF32: Type B3 (Ø 32:B5)

Installation:

Side carrier
Piston below

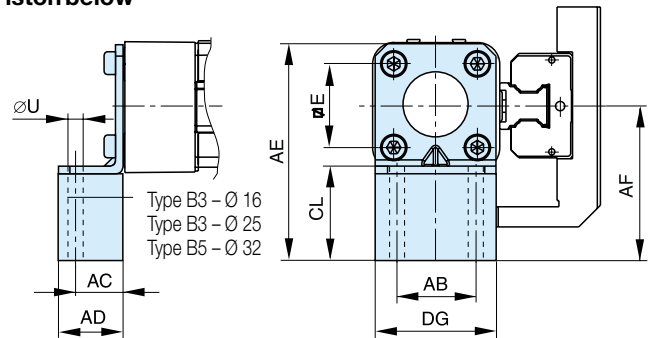

Drawing shows: Mounting with Guide Type STL

Series OSP-P STL16, STL25, STL32: Type B2
Series OSP-P KF16, KF25, KF32: Type B2

Installation:

Side carrier
Top piston

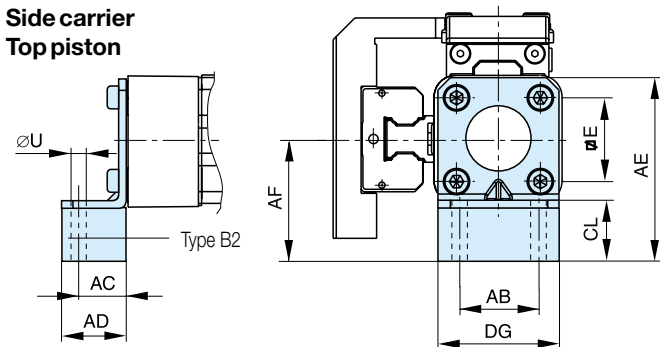

Drawing shows: Mounting with Guide Type STL

Dimensions [mm] for End Cap Mounting Type: B1 to B5

For series	E	ØU	AB	AC	AD	AE	AF	CL	DG	Order Code (pair)	
OSP-PSTL16	B1	18	3.6	18	10	14	28	15	2	26	21135FIL
OSP-PKF16	B2	18	3.6	18	10	14	43	30	17	26	21136FIL
	B3	18	3.6	18	10	14	55	42	29	26	21137FIL
OSP-PSTL25	B1	27	5.8	27	16	22	42	22	2.5	39	20311FIL
OSP-PKF25	B2	27	5.8	27	16	22	57	37	17.5	39	21138FIL
	B3	27	5.8	27	16	22	69	49	29.5	39	21139FIL
OSP-PSTL32	B1	36	6.6	36	18	26	55	30	3	50	20313FIL
OSP-PKF32	B2	36	6.6	36	18	26	69	44	17	50	21140FIL
	B5	36	6.6	36	18	26	90	65	9	50	21141FIL

Ø 40 - 50 mm End Cap Mounting

Type : C

for Linear Drives with Recirculating Ball Bearing Guide

- Series OSP-P STL
- Series OSP-P KF

Material:

Anodized aluminium.

The mountings are supplied in pairs.



Series OSP-P STL40, STL50: Type C1
Series OSP-P KF40, KF50: Type C1

Installation:

Top carrier
Side piston

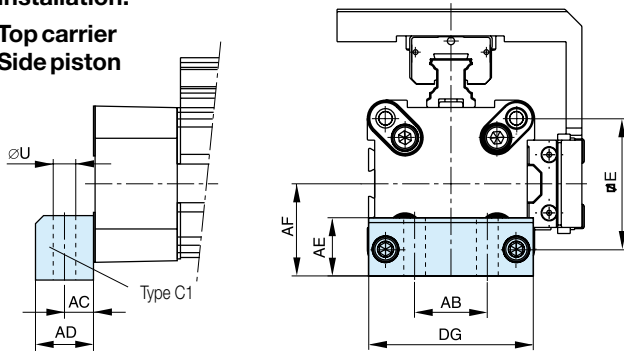

Drawing shows: Mounting with Guide Type STL

Series OSP-P STL40, STL50: Type C4 (Ø 50: C3)
Series OSP-P KF40, KF50: Type C4 (Ø 50: C3)

Installation:

Side carrier
Piston below

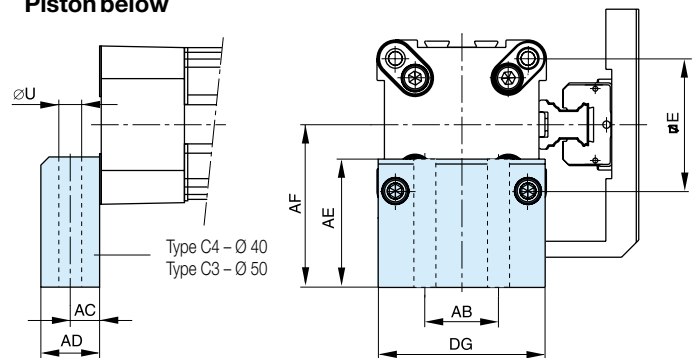

Drawing shows: Mounting with Guide Type STL

Series OSP-P STL40, STL50: Type C2
Series OSP-P KF40, KF50: Type C2

Installation:

Side carrier
Top piston

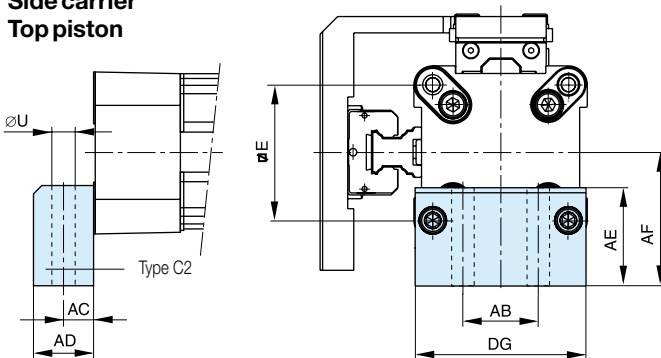

Drawing shows: Mounting with Guide Type STL

Dimensions [mm] for End Cap Mounting Type: C1 to C4

For series		E	øU	AB	AC	AD	AE	AF	DG	Order code (pair)
OSP-PSTL40	C1	54	9	30	12.5	24	24	38	68	4010FIL
OSP-PKF40	C2	54	9	30	12.5	24	37	51	68	20338FIL
	C4	54	9	30	12.5	24	56	70	68	20340FIL
OSP-PSTL50	C1	70	9	40	12.5	24	30	48	86	5010FIL
OSP-PKF50	C2	70	9	40	12.5	24	39	57	86	20349FIL
	C3	70	9	40	12.5	24	54	72	86	20350FIL

Ø 16 - 50 mm Mid Section Support

Type : D1ST

for Linear Drives with Recirculating Ball Bearing Guide

- Series OSP-P STL
- Series OSP-P KF

Note on Types D1ST

The mid-section support can also be mounted on the underside of the actuator, in which case its distance from the centre of the actuator is different..



Series OSP-P STL16 to STL50: Type D1ST

Series OSP-P KF16 to KF50: Type D1ST

Mountings from below with 2 screws

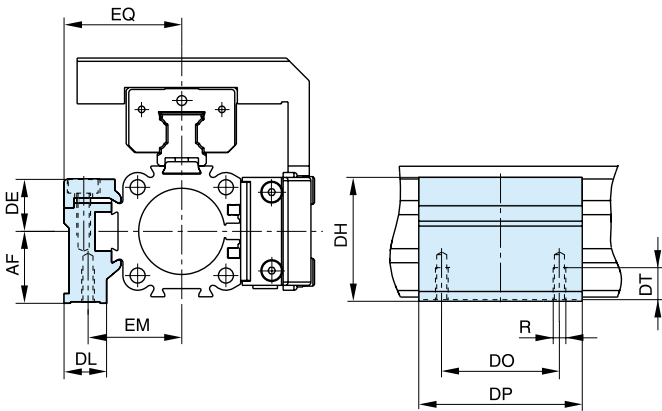

Drawing shows: Mounting with Guide Type STL

Dimensions [mm]

For series OSP-P ..	Mounting Type	R	AF	DE	DH	DL	DO
STL/KF16	D1ST	M3	15	14.2	29.2	14.6	18
STL/KF25	D1ST	M5	22	16	38	13	36
STL/KF32	D1ST	M5	30	16	46	13	36
STL/KF40	D1ST	M6	38	23	61	19	45
STL/KF50	D1ST	M6	48	23	71	19	45

For series OSP-P ..	Mounting Type	DP	DT	EM	EQ	Order No.
STL/KF16	D1ST	30	6.5	20	27	21125FIL
STL/KF25	D1ST	50	10	28.5	36	21126FIL
STL/KF32	D1ST	60	10	35.5	43	21127FIL
STL/KF40	D1ST	60	11	38	48	21128FIL
STL/KF50	D1ST	60	11	45	57	21129FIL

Order example: Type D1ST16

Order No. 21125FIL

Ø 16 - 50 mm Mid Section Support

Type : E1ST and E5ST

for Linear Drives with Recirculating Ball Bearing Guide

- Series OSP-P STL
- Series OSP-P KF

Series OSP-P STL16 to STL50: Type E1ST

Series OSP-P KF16 to KF50: Type E1ST



Installation:

Top carrier
Side position

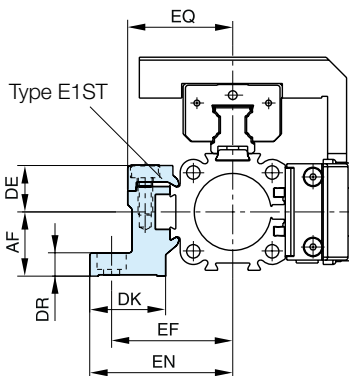

Mounting from above / below using a cap screw

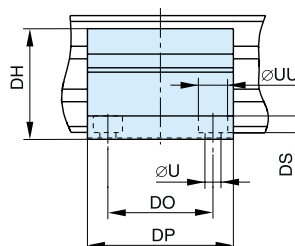

Drawing shows: Mounting with Guide Type STL

Mid Section Support

Type : E1ST to E5ST

for Linear Drives with Recirculating Ball Bearing Guide

- Series OSP-P STL
- Series OSP-P KF



Series OSP-P STL25 to STL50: Type E3ST, E4ST, E5ST
Series OSP-P STL25 to STL50: Type E3ST, E4ST, E5ST

Series OSP-P STL16 to STL50: Type E2ST
Series OSP-P KF16 to KFL50: Type E2ST

Installation:
Side carrier
Piston below

Installation:
Side carrier
Top piston

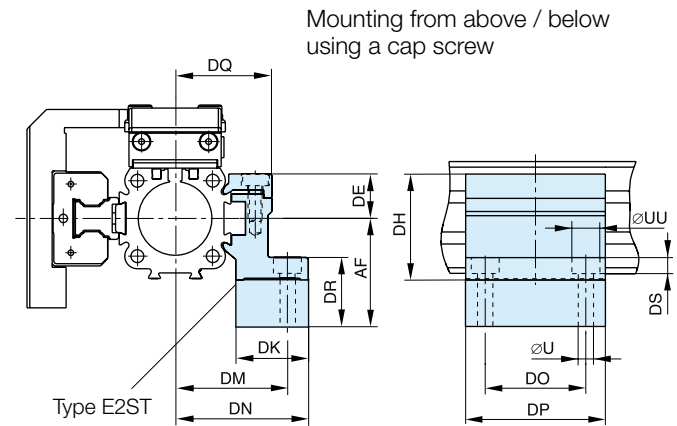
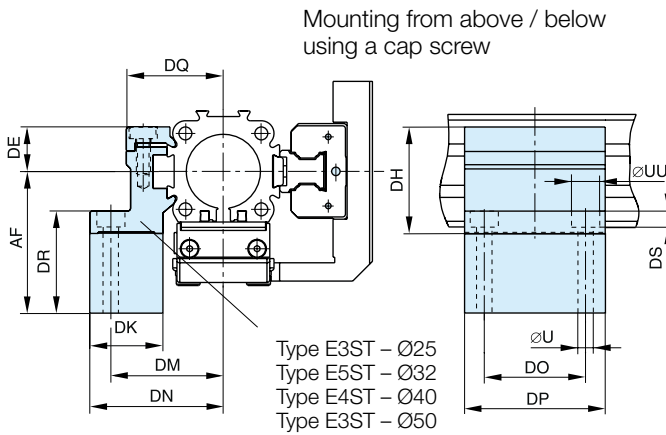

Drawing shows: Mounting with Guide Type STL

Drawing shows: Mounting with Guide Type STL

Dimensions [mm] for Mid-Section Support E1ST to E5ST

For series OSP-P..	Mounting Type	$\varnothing U$	$\varnothing UU$	AF	DE	DH	DK	DM	DN	DO	DP	DR	DQ	DS	EF	EN	EQ	Order No.
STL/KF16	E1ST	3.4	6	15	14.2	29.2	24	32	36.4	18	30	6	27	3.4	32	36.4	27	21130FIL
STL/KF16	E2ST	3.4	6	30	14.2	29.2	24	32	36.4	18	30	21	27	3.4	32	36.4	27	21142FIL
STL/KF25	E1ST	5.5	10	22	16	38	26	40	47.5	36	50	8	34.5	5.7	41.5	49	36	21131FIL
STL/KF25	E2ST	5.5	10	37	16	38	26	40	47.5	36	50	23	34.5	5.7	41.5	49	36	21143FIL
STL/KF25	E3ST	5.5	10	49	16	38	26	40	47.5	36	50	35	34.5	5.7	41.5	49	36	21148FIL
STL/KF32	E1ST	5.5	10	30	16	46	27	46	54.5	36	60	10	40.5	5.7	48.5	57	43	21132FIL
STL/KF32	E2ST	5.5	10	44	16	46	27	46	54.5	36	60	24	40.5	5.7	48.5	57	43	21144FIL
STL/KF32	E5ST	5.5	10	65	16	46	27	46	54.5	36	60	45	40.5	5.7	48.5	57	43	21151FIL
STL/KF40	E1ST	7	-	38	23	61	34	53	60	45	60	10	45	-	56	63	48	21133FIL
STL/KF40	E2ST	7	-	51	23	61	34	53	60	45	60	23	45	-	56	63	48	21145FIL
STL/KF40	E4ST	7	-	70	23	61	34	53	60	45	60	42	45	-	56	63	48	21150FIL
STL/KF50	E1ST	7	-	48	23	71	34	59	67	45	60	10	52	-	64	72	57	21134FIL
STL/KF50	E2ST	7	-	57	23	71	34	59	67	45	60	19	52	-	64	72	57	21146FIL
STL/KF50	E3ST	7	-	72	23	71	34	59	67	45	60	34	52	-	64	72	57	21149FIL

Order example: Type E1ST16

Order No. 21130FIL



Ø 16-80 mm Inversion Mounting

for Linear Drive

- Series OSP-P

In dirty environments, or where there are special space problems, inversion of the cylinder is recommended.

The inversion bracket transfers the driving force to the opposite side of the cylinder. The size and position of the mounting holes are the same as on the standard cylinder.

Stainless steel version on demand.

Please note:

Other components of the OSP system such as mid-section supports, magnetic switches and the external air passage for the P16, can still be mounted on the free side of the cylinder.

Note:

When combining single end porting with inversion mountings, RS magnetic switches can only be mounted directly opposite to the external air-supply profile.

Important Note:

May be used in combination with Clevis Mounting, ref. dimensions on page 92.



Series OSP-P16 to 32

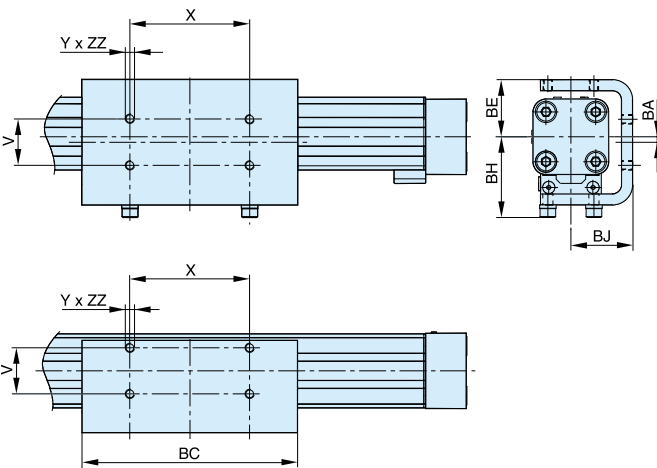

Series OSP-P40 to 80

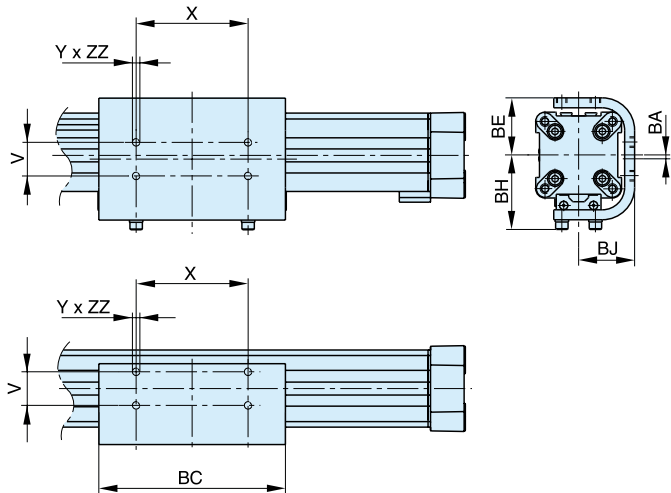

Dimensions [mm]

For series	V	X	Y	BA	BC	BE	BH	BJ	ZZ	Order No.
OSP-P16	16,5	36	M4	2	69	23	33	25	4	20446FIL
OSP-P25	25	65	M5	3	117	31	44	33,5	6	20037FIL
OSP-P32	27	90	M6	3	150	38	52	39,5	6	20161FIL
OSP-P40	27	90	M6	3	150	46	60	45	8	20039FIL
OSP-P50	27	110	M6	1	200	55	65	52	8	20166FIL
OSP-P63	34	140	M8	2,5	255	68	83,5	64	10	20459FIL
OSP-P80	36	190	M10	3,5	347	88	107,5	82	15	20490FIL

Note:

Order instructions in combination with basic cylinder see page 25, pos. 20

For rodless pneumatic cylinder OSP-P overview see page 5

Ø 16 - 50 mm Adaptor Profile

for Linear Drive

- Series OSP-P

Adaptor Profile OSP

- A universal attachment for mounting of valves etc.
- Solid material



Series OSP-P16 to 50

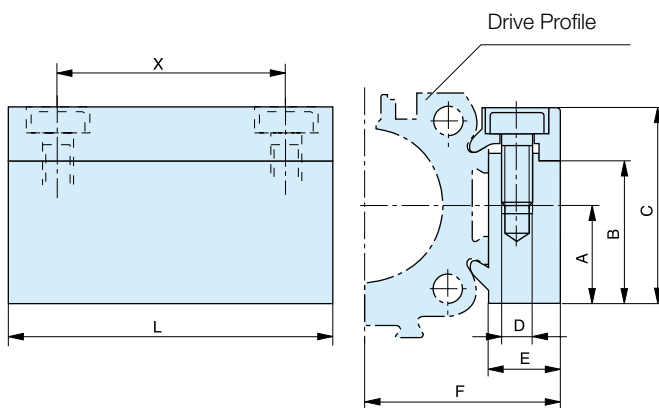

Dimensions [mm]

For series	A	B	C	D	E	F
OSP-P16	14	20.5	28	M3	12	27
OSP-P25	16	23	32	M5	10.5	30.5
OSP-P32	16	23	32	M5	10.5	36.5
OSP-P40	20	33	43	M6	14	45
OSP-P50	20	33	43	M6	14	52

For series	L	X	Order No.	
			Standard	Stainless
OSP-P16	50	38	20432FIL	20438FIL
OSP-P25	50	36	20006FIL	20186FIL
OSP-P32	50	36	20006FIL	20186FIL
OSP-P40	80	65	20025FIL	20267FIL
OSP-P50	80	65	20025FIL	20267FIL

Series OSP-P63 to 80

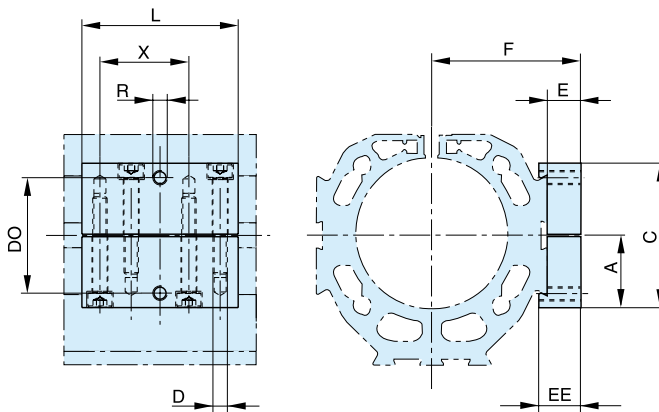

Dimensions [mm]

For series	A	C	D	E	F	L
OSP-P63	30	60	M6	14	62	65
OSP-P80	30	60	M6	14	75	65

For series	R	X	EE	DO	Order No.*
OSP-P63	M6	37	17,5	48	20792ZFIL
OSP-P80	M6	37	17,5	48	20792ZFIL

* Stainless version

For **rodless pneumatic cylinder OSP-P** overview see page 5



Ø 16 - 50 mm T-Slot Profile

for Linear Drive

- Series OSP-P



T-Slot Profile OSP

- A universal attachment for mounting with standard T-Nuts

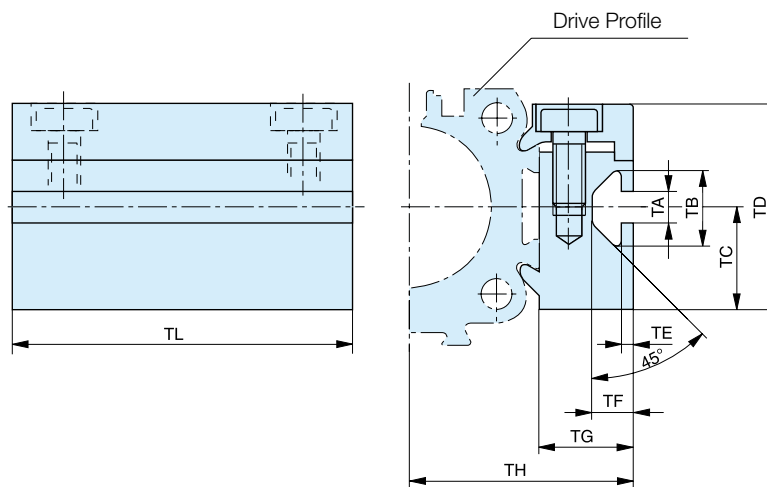

Dimensions [mm]

For series	TA	TB	TC	TD	TE	TF	TG	TH	TL	Order No.	
										Standard	Stainless
OSP-P16	5	11.5	14	28	1.8	6.4	12	27	50	20433FIL	20439FIL
OSP-P25	5	11.5	16	32	1.8	6.4	14.5	34.5	50	20007FIL	20187FIL
OSP-P32	5	11.5	16	32	1.8	6.4	14.5	40.5	50	20007FIL	20187FIL
OSP-P40	8.2	20	20	43	4.5	12.3	20	51	80	20026FIL	20268FIL
OSP-P50	8.2	20	20	43	4.5	12.3	20	58	80	20026FIL	20268FIL

Following T-nuts from the company ITEM could be used:

Cyl.-Series	T-nut St5	T-nut St8
OSP-P16-32	✓	
OSP-P40-50		✓

For **rodless pneumatic cylinder OSP-P** overview see page 5

Ø 16 - 50 mm Connection Profile

for combining

- Series OSP-P
with system profiles
- Series OSP-P with Series OSP-P

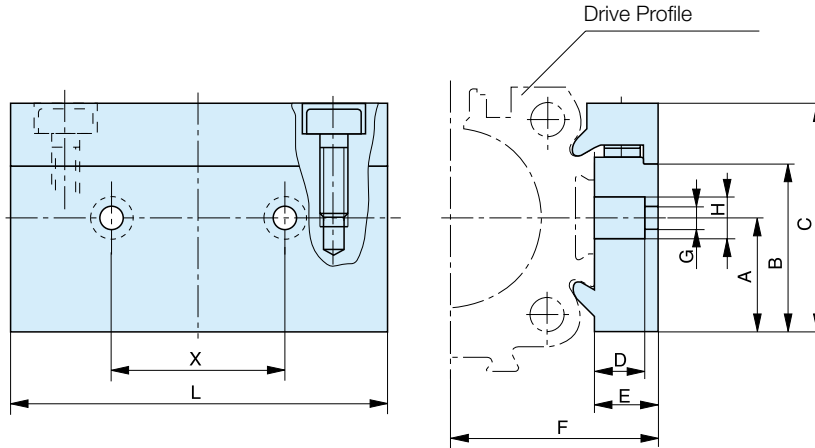

Dimensions [mm]

For series	for mounting on the carrier of	A	B	C	D	E	F	G	H	L	X	Order No.
OSP-P16	OSP25	14	20.5	28	8.5	12	27	5.5	10	50	25	20849FIL
OSP-P25	OSP32-50	16	23	32	8.5	10.5	30.5	6.6	11	60	27	20850FIL
OSP-P32	OSP32-50	16	23	32	8.5	10.5	36.5	6.6	11	60	27	20850FIL
OSP-P40	OSP32-50	20	33	43	8	14	45	6.6	11	60	27	20851FIL
OSP-P50	OSP32-50	20	33	43	8	14	52	6.6	11	60	27	20851FIL

Possible Combinations

Combination of Series OSP-P with system profiles



Combination of Series OSP-P with Series OSP-P



For **rodless pneumatic cylinder OSP-P** overview see page 5

Ø 25 - 50 mm Duplex Connection

For connection of cylinders of the Series OSP-P

The duplex connection combines two OSP-P cylinders of the same size into a compact unit with high performance.

Features

- increased load and torque capacity
- higher driving forces

Included in delivery:

- 2 clamping profiles with screws
- 1 mounting plate with fixings

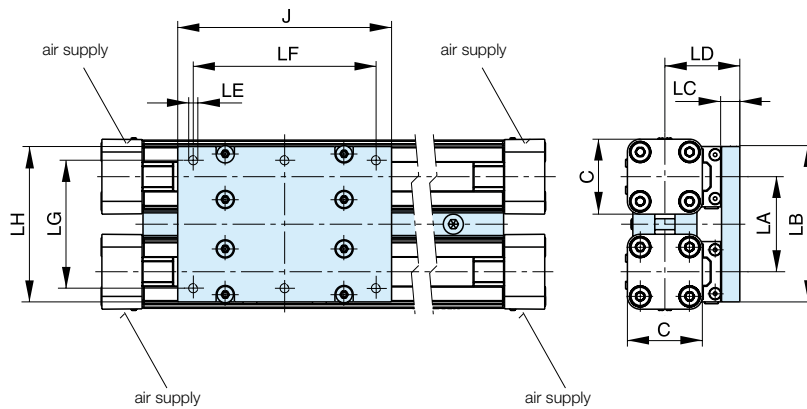

Dimensions [mm]

For series	C	J	LA	LB	LC	LD	LE	LF	LG	LH	Order No.	
											Standard	Stainless
OSP-P25	41	117	52	86	10	41	M5	100	70	85	20153FIL	20194FIL
OSP-P32	52	152	64	101	12	50	M6	130	80	100	20290FIL	20291FIL
OSP-P40	69	152	74	111	12	56	M6	130	90	110	20156FIL	20276FIL
OSP-P50	87	200	88	125	12	61	M6	180	100	124	20292FIL	20293FIL

Note:
Order instructions in combination with basic cylinder
see page 25, pos. 20

For **rodless pneumatic cylinder OSP-P** overview
see page 5

Ø 25 - 50 mm Multiplex Connection

For connection of cylinders of the Series OSP-P

The multiplex connection combines two or more OSP-P cylinders of the same size into one unit.

Features

- The orientation of the carriers can be freely selected

Included in delivery:

- 2 clamping profiles with clamping screws



Installation: Top carrier / Top carrier

Installation: Top carrier / Side carrier

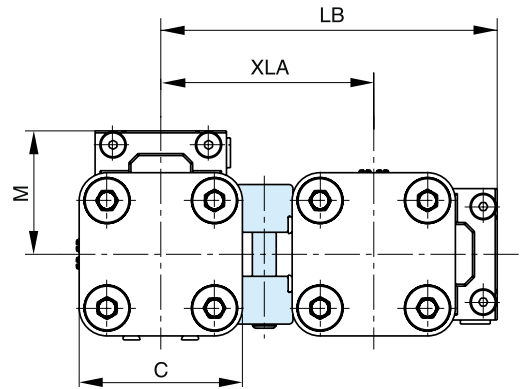
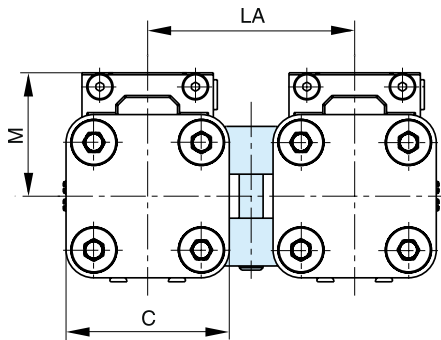

Dimensions [mm]

For series	C	M	LA	LB	XLA	Order No.	
						Standard	Stainless
OSP-P25	41	31	52	84.5	53.5	20035FIL	20193FIL
OSP-P32	52	38	64	104.5	66.5	20167FIL	20265FIL
OSP-P40	69	44	74	121.5	77.5	20036FIL	20275FIL
OSP-P50	87	49	88	142.5	93.5	20168FIL	20283FIL

For **rodless pneumatic cylinder OSP-P** overview see page 5

Ø 10 - 80 mm Magnetic Switches P8S-G

Type **RST**
EST



The next generation of T-slot switches is appealing due to its ease of attachment without the use of special tools. Due to the new electronics, the hysteresis is especially narrow, allowing for a highly accurate switching point.

Magnetic switches are used for electrical sensing of the position of the piston, e.g. at its end positions. They can also be used for sensing of intermediate positions.

Sensing is contactless, based on magnets which are built-in as standard. A yellow LED indicates operating status.

The magnetic switches are attached with an adapter directly in the dovetail groove of the OSP cylinder.

The possible operating speed of the load carrier or carrier bolt must account for the minimum response time of downstream devices. Accordingly, the switching distance is included in the calculation.

$$\text{Minimum response time} = \frac{\text{Switching distance}}{\text{Overrun speed}}$$

- for the magnetic switch temperature range, please take into account the surface temperature and the self-heating properties of the linear drive.

Characteristics	Series P8S-GR / P8S-GE	Series P8S-GP
Electrical Characteristics		
Switching output / -function	Reed / NO Reed / NC	PNP / NO
Electrical configuration	2-wire	3-wire
Display LED yellow	yes (not Reed NC)	
Operating voltage U_b	10 - 30 V AC/DC	10 - 30 V DC
Ripple of U_b	$\leq 10\%$	$\leq 10\%$
Voltage drop	$\leq 3\text{V}$	$\leq 2\text{V}$
Power consumption @ $U_b = 24\text{V}$ switched on, without load	-	$\leq 10\text{mA}$
Permanent current	$\leq 500\text{mA}$	$\leq 200\text{mA}$
Breaking capacity	$\leq 6\text{W}$	-
Switchable capacity load @ 100 W @ 24 V DC	100 nF	-
Switching frequency	$\leq 400\text{Hz}$	$\leq 1,000\text{Hz}$
Time delay before availability (on/off)	1.5 / 0.5 ms	0.5 / 0.5 ms
Repeatability	$\leq 0.2\text{mm}$	$\leq 0.2\text{mm}$
Switching distance	approx. 15 mm	approx. 15 mm
Hysteresis	2 mm	2 mm
EMC following EN 60947-5-2	yes	yes
Lifetime	$\geq 20 \times 10^6$ cycles	unlimited
Short-circuit protection	-	yes
Reverse polarity prot.	-	yes
Power-up pulse suppression	-	yes
Protection for inductive load	-	yes
ATEX - Certification	-	on request
Mechanical Characteristics		
Housing	PA12	
Cable type	PUR / black	
Cable cross section	$2 \times 0.14\text{mm}^2$	$3 \times 0.14\text{mm}^2$
Bending radius fixed	$\geq 30\text{mm}$	
Bending radius moving	$\geq 45\text{mm}$	
Ambient		
Protection class to EN 60529	IP 68	
Ambient temperature range 1)	$-30\text{ }^\circ\text{C}$ to $+80\text{ }^\circ\text{C}$	
Vibration to EN 60068-2-6	G 30, 11 ms, 10 to 55 Hz, 1 mm	
Shock to EN 60068-2-27	G 50, 11 ms	

Magnetic Switches RST and EST

Electrical Service Life, Protective Measures

Magnetic switches are sensitive to excessive currents and inductions. With high switching frequencies and inductive loads such as relays, solenoid valves or lifting magnets, service life will be greatly reduced.

With **resistive and capacitive loads** with high switch-on current, such as light bulbs, a protective resistor should be fitted. This also applies to long cable lengths.

In the switching of inductive loads such as relays, solenoid valves and lifting magnets, voltage peaks (transients) are generated which must be suppressed by protective diodes, RC loops or varistors.

Connection Examples

- Load with protective circuits
- (a) Protective resistor for light bulb
- (b) Freewheel diode on inductivity
- (c) Varistor on inductivity
- (d) RC element on inductivity

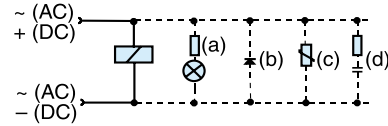

For the type EST, external protective circuits are not normally needed.

Type: RST

In the type RST contact is made by a mechanical **reed switch** encapsulated in glass.

Electrical Connection: cable type RS-K

Reed 2-wire

Normally open

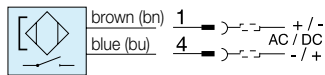

Normally closed

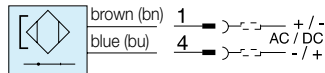

Type: EST

In the type EST contact is made by an **electronic switch** – without bounce or wear and protected from pole reversal. The output is short circuit proof and insensitive to shocks and vibrations.

A cable with connector and open end can be ordered separately.

Electrical Connection: cable type ES-K

PNP 3-wire

Normally open

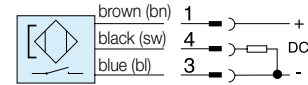

Electrical Connection: plug type RST-S

Reed 2-wire

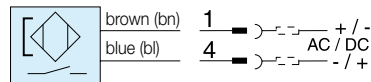

Electrical Connection: plug type EST-S

PNP 3-wire

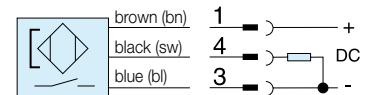

Dimensions [mm] - Typ RST-K, EST-K - Series P8S-G

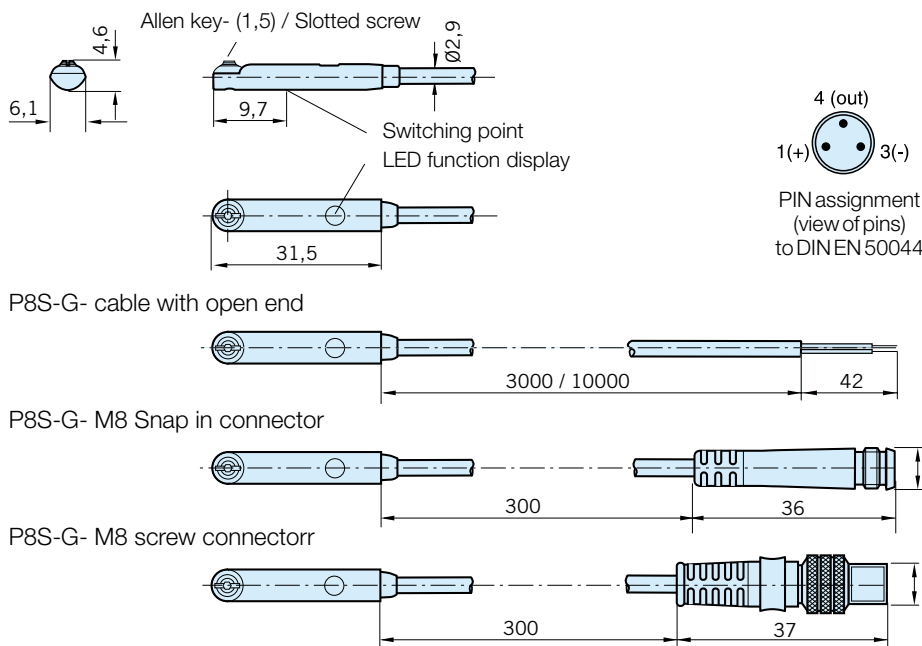

Installation instructions for the RST/EST magnetic switches series P8S-G

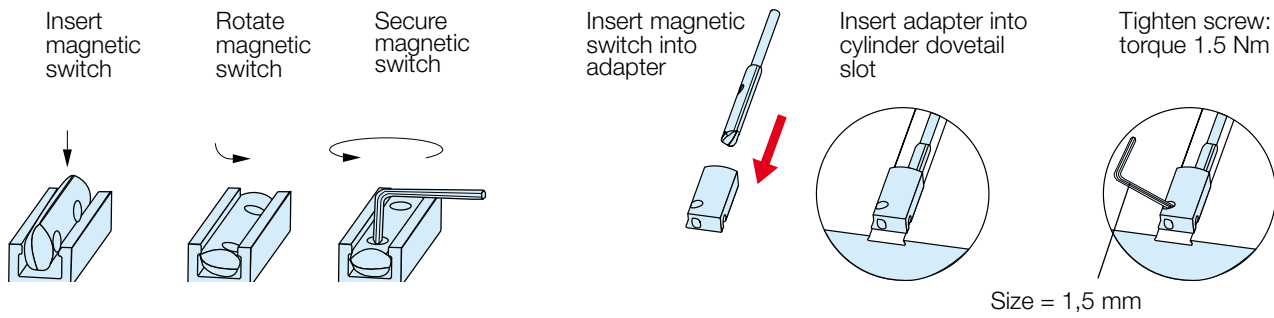

Dimensions adapters for RST/EST magnetic switch series P8S-G

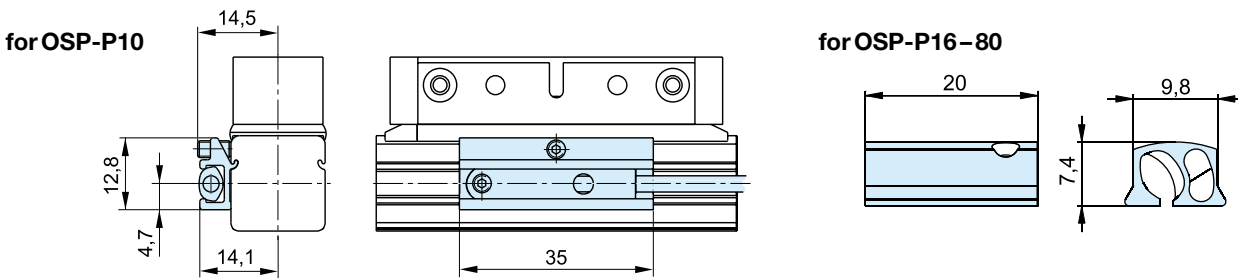

Note for OSP-P10: Switches can not be mounted directly opposite of the carrier !

P8S-G mounting positions in the Basic Guide cylinder profile

Cylinder profile

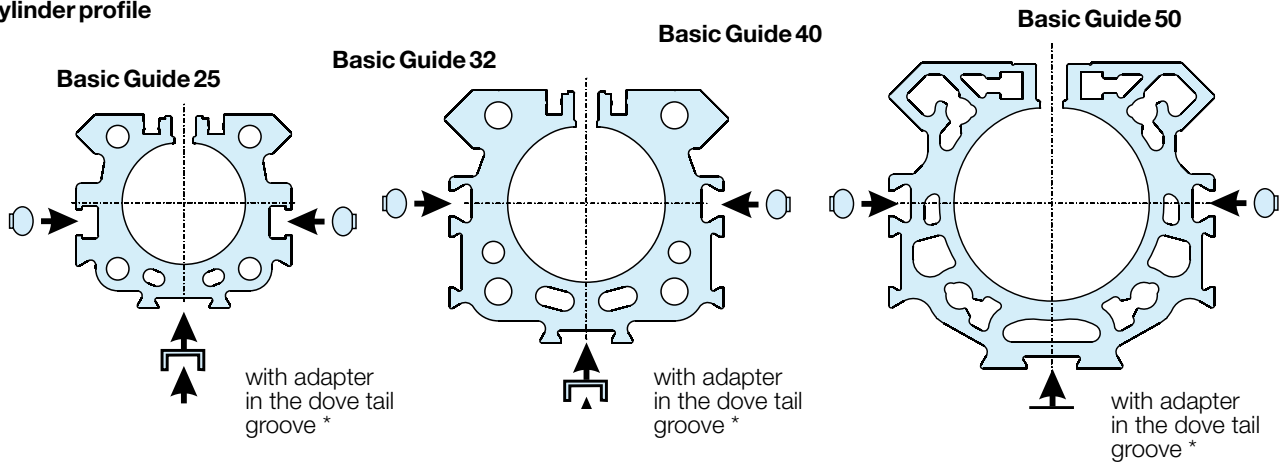

* Adapter is included in the scope of delivery of the P8S-G T-slot switches.

Dimensions for P8S-G T-Slot magnetic switches with adapter in the cylinder profile of the Basic Guide 25-50

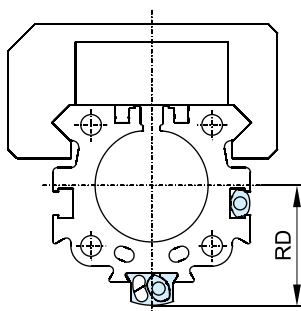

Series	Dimension [mm] RD
OSPP-BG25	27
OSPP-BG32	33.5
OSPP-BG40	39
OSPP-BG50	48

Order Instructions

Version	Voltage	Type	Order No.
Magnetic switch, reed contact, normally open LED indicator, cable 3 m	10-30 V AC / DC	RST-K	P8S-GRFAX
Magnetic switch, reed contact, normally open LED indicator, cable 10 m	10-30 V AC / DC	RST-K	P8S-GRFDX
Magnetic switch, reed contact, normally open, screw connector M8, LED indicator, cable 0.3 m	10-30 V AC / DC	RST-S	P8S-GRCHX
Magnetic switch, reed contact, normally closed, cable 10 m	10-30 V AC / DC	RST-K	P8S-GEFRX
Magnetic switch, electronic, PNP LED indicator, cable 3 m	10-30 V DC	EST-K	P8S-GPFAX
Magnetic switch, electronic, PNP LED indicator, cable 10 m	10-30 V DC	EST-K	P8S-GPFDX
Magnetic switch, electronic, PNP screw connector M8, LED indicator, cable 0.3 m	10-30 V DC	EST-S	P8S-GPCHX

Included in delivery:

1 magnetic switch, 1 adapter for T-slot magnetic switch for type OSP-P16 up to OSP-P80.

Note: When using T-nut magnetic switches with the OSP-P10, please order the adapter Order No. 8872FIL separately.

Accessories

Description	Type	Order No.
Cable M8, 2.5 m without lock nut	KS 25	KY 3240
Cable M8, 5.0 m without lock nut	KS 50	KY 3241
Cable M8, 10.0 m without lock nut	KS 100	KC 3140
Cable M8, 2.5 m with lock nut	KSG 25	KC 3102
Cable M8, 5.0 m with lock nut	KSG 50	KC 3104
Adapter for RST/EST magnetic switch – for type OSP-P10	HMTP010	8872FIL
Adapter for RST/EST magnetic switch – for type OSP-P16 up to OSP-P80 (pack of 10)		KL 3333

Ø 10 - 80 mm Magnetic Switches

Series: **RS-K..ATEX**
ES-K..ATEX

OSP
ORIGA
SYSTEM
PLUS



For electrical sensing of the carrier position, e.g. at the end positions, magnetic switches may be fitted. Position sensing is contactless and is based on magnets fitted as standard to the carrier. A yellow LED indicates operating status.

The magnetic switches are attached directly in the dovetail groove of the OSP cylinder.

Characteristics	Type RS-K ATEX	Type ES-K ATEX
Elektrical Characteristics		
ATEX Certification	yes	yes
Category Type: RS-K	⊕ II 3GD EEX nC IIC T3 146 °C	
Category Type: ES-K	⊕ II 2GD EEX ib IIC T5 100 °C	
Switching output	Reed	NAMUR
Operating voltage	10-240 V AC/DC	7-10 V DC
Voltage drop	≤ 3V	–
Electrical configuration	Two wire	Two wire
Output function	normally open	normally open
Permanent current	≤ 200 mA	≤ 3 mA
Power consumption	≤ 10/10 W/VA peak	–
Peak current	≤ 500 mA	–
Power consumption without load	–	≤ 1 mA
Function indicator	LED, yellow	
Response time On/Out	≤ 2 ms	≤ 0.5 ms
Sensitivity	2-4 mT	2-4 mT
Reverse polarity prot.	yes	yes
Short-circuit protection	no	yes
Repeatability	≤ 0.2 mm	≤ 0.2 mm
Hysteresis	≤ 1.5 mm	≤ 1.5 mm
EMC	EN 60947-5-2	
Lifetime	≥ 10 Mio. Cycles with PLC load	
Mechanical Characteristics		
Housing	Makrolon, smoke color	
Cable cross section	2x0.14 mm ²	2x0.14 mm ²
Cable type	PVC, blau	PVC, blue
Weight	ca. 0.075 kg	
Degree of protection	IP67 to EN 60529	
Ambient temperature range ¹⁾	-25 °C to +80 °C	-20 °C to +75 °C
Surface temperature	The maximum surface temperature T=146 °C is referred to the max. ambiente temperature of 80 °C	–
Shock resistance		
Vibration and Shock	50 G at 50 Hz and 1 mm	

- for the magnetic switch temperature range, please take into account the surface temperature and the self-heating properties of the linear drive.

For **Linear Drives in ATEX-Version** see page 35

Magnetic Switches

Type: RS-K ATEX-Version

In the type RS contact is made by a mechanical **reed switch** encapsulated in glass.

ATEX-Category Type: RS-K

⊕ II 3GD EEX nC IIC T3 146°C

Electrical Service Life Protective Measures

Magnetic switches are sensitive to excessive currents and inductions. With high switching frequencies and inductive loads such as relays, solenoid valves or lifting magnets, service life will be greatly reduced.

With **resistive and capacitive loads** with high switch-on current, such as light bulbs, a protective resistor should be fitted. This also applies to long cable lengths.

In the switching of inductive loads such as relays, solenoid valves and lifting magnets, voltage peaks (transients) are generated which must be suppressed by protective diodes, RC loops or varistors.

Connection Examples

Load with protective circuits

- (a) Protective resistor for light bulb
- (b) Freewheel diode on inductivity
- (c) Varistor on inductivity
- (d) RC element on inductivity

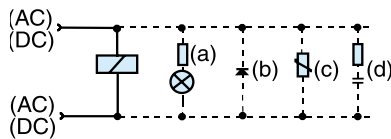

Type: ES-K ATEX-Version

In the type ES contact is made by an **electronic switch** – without bounce or wear and protected from pole reversal. The output is short circuit proof and insensitive to shocks and vibrations.

ATEX-Category Type: ES-K

⊕ II 2GD EEX ib IIC T5 100°C

Note!

The connection of the magnetic switch Type ES-K ATEX must be realised by means of an EEX i switching amplifier (see Accessories).

Electrical Connection: cable type RS-K ATEX

Normally open (Reed)

2-wire

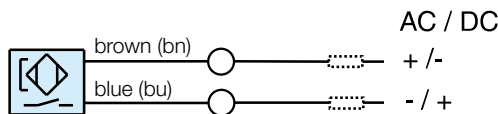

Electrical Connection: cable type ES-K ATEX

Normally open (NAMUR)

2-wire

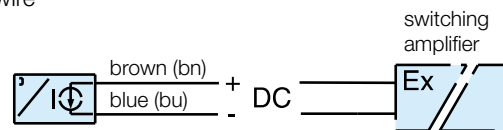

Dimensions [mm]

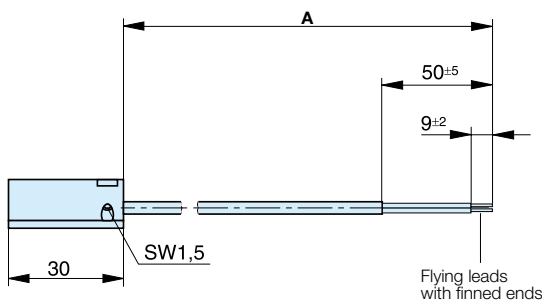

Dimension [mm]

Magnetic switch Order No.	Nominal cable length A	Lengths tolerance
KL3240	5000	- 50
KL3241	10000	- 50
KL3250	5000	- 50
KL3251	10000	- 50

Order Instructions

Version	Voltage	Type	Order No.
Magnetic switch, reed contact, normally open LED indicator, cable 5 m	10-240 V AC/DC	RS-K ATEX	KL3240
Magnetic switch, reed contact, normally open LED indicator, cable 10 m	10-240 V AC/DC	RS-K ATEX	KL3241
Magnetic switch, electronic, NAMUR, normally open LED indicator, cable 5 m	7-10 V DC	ES-K ATEX	KL3250
Magnetic switch, electronic, NAMUR, normally open LED indicator, cable 10 m	7-10 V DC	ES-K ATEX	KL3251

Accessories

Description	for magnetic switch	Order No.
2 channel switching amplifier 24 V DC	ES-K ATEX	2876FIL
2 channel switching amplifier 220 V AC	ES-K ATEX	1546FIL

Note: 2 magnetic switches can be connected to each switching amplifier.

Linear Drive Accessories

Ø16-80 mm Cable Cover

For clean guidance of magnetic switch cables along the cylinder body.

Contains a maximum of 3 cables with diameter 3 mm.

Material: Plastic

Temperature Range: -10 to +80 °C



Dimension [mm] and Order Instructions

Series	Dimensions [mm]		Order No.
	RC	RD	
OSP-P16	18.5	19	13039FIL
OSP-P25	23.5	25.5	
OSP-P32	29.5	32	Minimal length: 1 m
OSP-P40	34.5	37.5	Max. profile length: 2 m
OSP-P50	41.5	46.5	Multiple profiles can be used.
OSP-P63	51.5	57.5	
OSP-P80	64.5	70.5	

Dimension [mm]

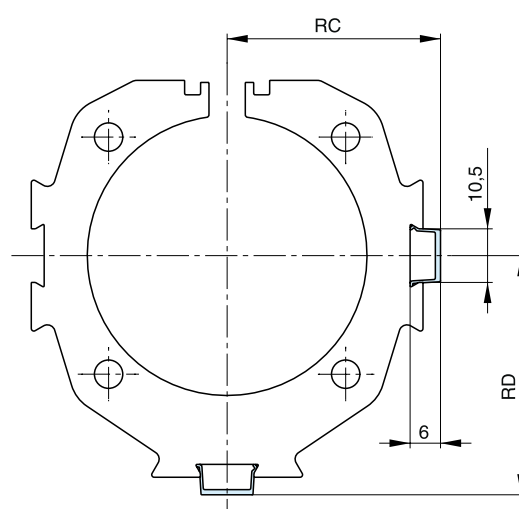

ORIGA-SENSOFLEX

Displacement Measuring System for automated movement

Series SFI-plus
(Incremental measuring system)



Characteristics:

- Contactless magnetic displacement measurement system
- Displacement length up to 32 m
- Resolution 0.1 mm (option: 1 mm)
- Displacement speed up to 10m/s
- For linear and non-linear rotary motion
- Suitable for almost any control or display unit with a counter input

The SFI-plus magnetic displacement measuring system consists of 2 main components.

- **Measuring Scale**
Self-adhesive magnetic measuring scale
- **Sensing Head**
Converts the magnetic poles into electrical signals which are then processed by counter inputs down stream
(e.g. PLC, PC, digital counter)

Note: Order instructions in combination with basic cylinder see page 25, pos.25

Characteristics	Description	
Type	21210FIL	21211FIL
Output Function		
Resolution	0.1mm	1mm
Pole lengths magnetic scale	5mm	
Maximum speed	10m/s	
Repeat accuracy	± 1 Increment	
Distance between sensor and scale	< 2 mm	
Tangential deviation	≤ 3° / ≤ 1°	
Lateral deviation	≤ ± 1.5 mm	
Switching output	push / pull	
Electrical characteristics		
Operating voltage U_b	10–30 VDC	
Voltage drop	≤ 2 V	
Continuous current for each output	≤ 40 mA	
Power consumption at $U_b = 24V$, switched on, without load	≤ 15 mA	
Short-circuit protection	yes	
Reverse polarity protection	yes	
Protection from inductive load	yes	
EMC		
Emission standard for industrial	DIN EN 61000-6-4	
Immunity for industrial environments	DIN EN 61000-6-2	
Mechanical Characteristics		
Housing material	Aluminium	
Cable length	5.0 m – casted, flying lead	
Cable cross section	2 x 0.14 mm ² + 2 x 0.22 mm ²	
Cable type	PUR, black	
Bending radius, moving	≥ 50 mm	
Weight (mass)	appr. 0.165 kg	
Environmental Conditions / Shock Resistance		
Degree of protection	IP67 to EN60529	
Ambient temperature range	-25 °C to +85 °C	
Vibration stress to EN 60068-2-6	300 m/s ² , 55 Hz...2 kHz	
Shock to EN 60068-2-27	300 m/s ² , 11 ms	

Sensing Head

The sensing head provides two pulsating, 90° out of phase counter signals (phase A/B) with a 0.1 mm resolution (option 1 mm).

The counting direction can be determined automatically from the phase variance of the counter signals.

Electrical Connection

Colour	Function
red (RD)	10 ... 30VDC
black (BK)	ground
yellow (YE)	signal A
green (GN)	signal B
shield	shielding

Output Signal- Sensing Head

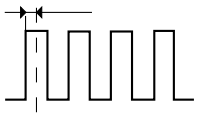
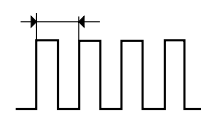
$U_a = U_e$	Phase B	U_{a1}	0°	
	Phase A	U_{a2}	90°	

Dimensions [mm] - Sensing Head

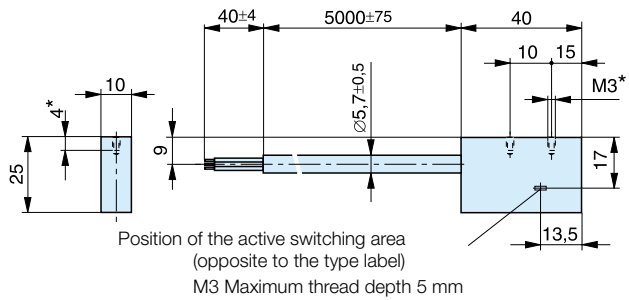

SFI-plus mounted on a rodless cylinder series OSP-P

The SFI-plus system can be mounted directly on a rodless OSP-P cylinder with the special mounting kit. The position of the sensing head is generally 90° to the carrier.

Note: Impulse Frequency:

Pole distance of the magnetic measurement scale is 5 mm.

Impulse generation depends on the SFI-plus type used. The proportional output frequency of the signal impulses increases as the travel speed goes up.

The cycle frequency of the downstream counter input must be set accordingly.

Combinations consisting of SFI-plus and OSP-P Cylinders with guides are available on request.



Displacement measuring system	Resolution [mm]	Velocity [m/sec]	Output frequency [kHz]
SFI-plus 21210FIL	0.1	1	10
SFI-plus 21211FIL	1	1	1

OSP-P Modular Pneumatic Linear Drive Systems

Dimensions – in combination with OSP-P cylinders

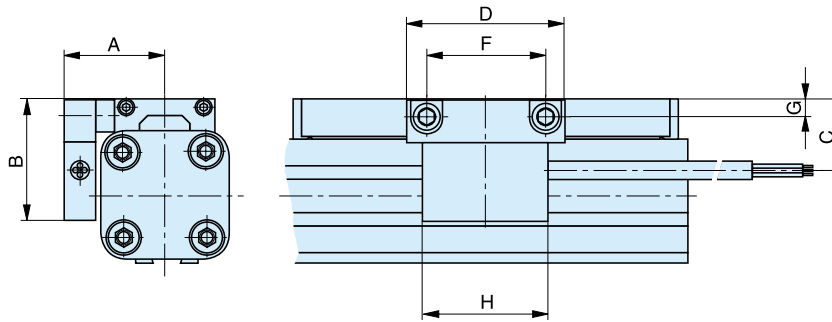

Dimensions [mm]

Serie	A	B	C	D	F	G	H
OSP-P25	31	43	23	50	38	5.5	40
OSP-P32	37	50	30	50	38	6.5	40
OSP-P40	42	54	34	50	38	6.5	40
OSP-P50	49	59	39	50	38	6.5	40
OSP-P63	59	73	49	50	38	10	40
OSP-P80	72	90	64	50	38	12	40

Order Instructions

Description

Sensing head with measuring scale – Resolution 0.1 mm (please order overall length *)

21240-measurement scale [mm], 5 digits

Option: Sensing head with measuring scale – Resolution 1 mm (please order overall length *)

21241-measurement scale [mm], 5 digits

Sensing head – Resolution 0.1 mm (spare part)

21210FIL

Option: Sensing head – Resolution 1 mm (spare part)

21211FIL

Measuring scale per meter (spare part)

21235FIL

Mounting kit for OSP-P25

21213FIL

Mounting kit for OSP-P32

21214FIL

Mounting kit for OSP-P40

21215FIL

Mounting kit for OSP-P50

21216FIL

Mounting kit for OSP-P63

21217FIL

Mounting kit for OSP-P80

21218FIL

* Overall length of the measuring scale results from stroke length of the cylinder + dead length
Dead length for linear drives series OSP-P see table.

Note: Order instructions in combination with basic cylinder see page 25, pos. 25

Series	Dead length [mm]
OSP-P 25	154
OSP-P 32	196
OSP-P 40	240
OSP-P 50	280
OSP-P 63	350
OSP-P 80	422

Example:

Cylinder OSP-P, Ø25 mm, stroke length 1000 mm

dead length + stroke length = overall length of the measuring scale

154 mm + 1000 mm = 01154 mm

Please use this order pattern: 21240-01154

OSP-P Modular Pneumatic Linear Drive Systems

Total overview of options (not all of them can be combined !)

1-4	5+6	7	8	9	10	11	12-16	17	
OSPP	25	0	0	0	0	0	01100	0	

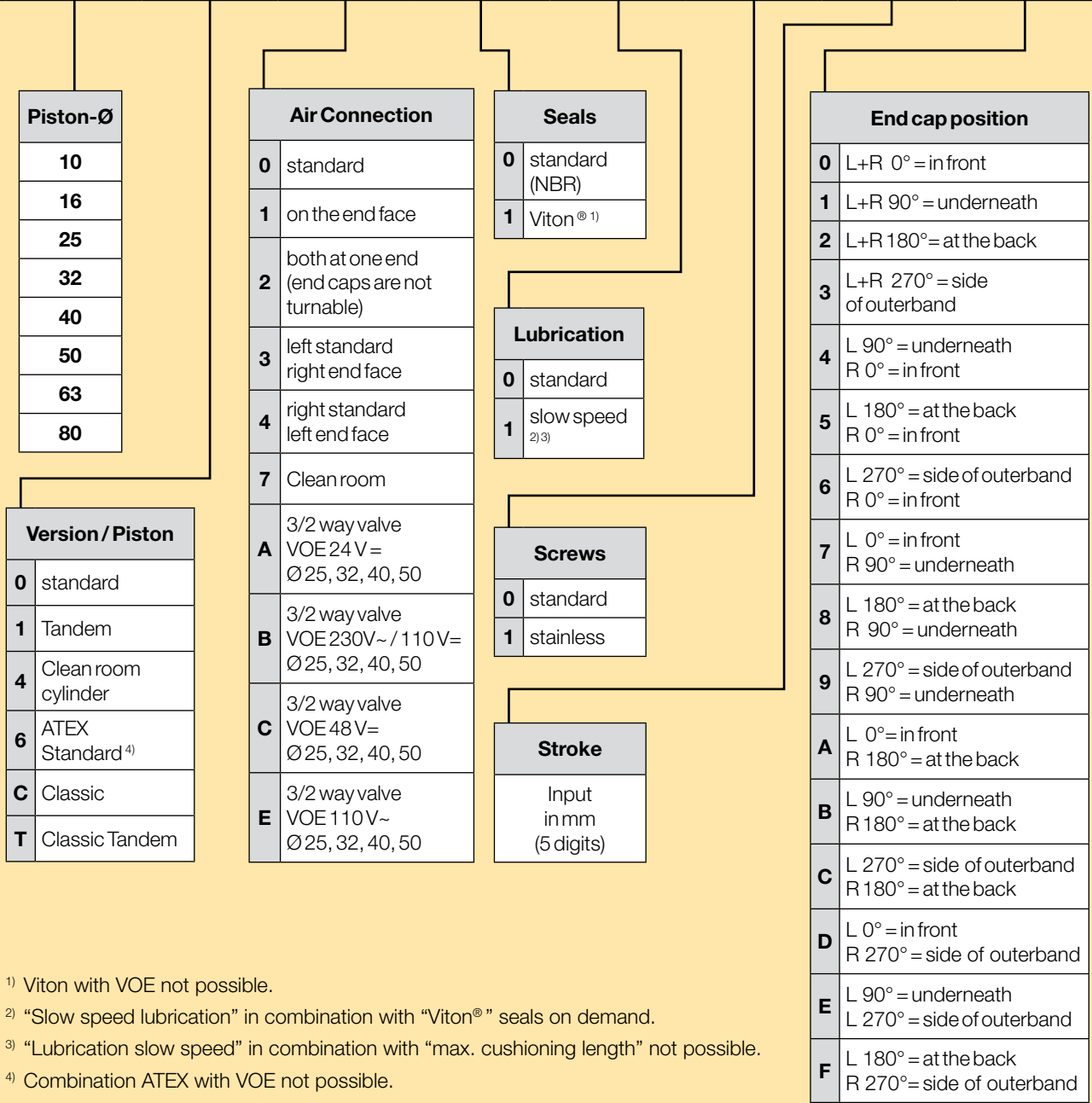

1) Viton with VOE not possible.
 2) "Slow speed lubrication" in combination with "Viton®" seals on demand.
 3) "Lubrication slow speed" in combination with "max. cushioning length" not possible.
 4) Combination ATEX with VOE not possible.

OSP-P Modular Pneumatic Linear Drive Systems

	18	19	20	21	22	23	24	25	
	0	0	0	0	0	0	0	0	
	Cushioning	Piston Mounting	Guides/ Brakes/ Inversion	add. Guide Carriage	Cover / Cable Channel	Measuring system			
0	standard	0	without	0	without	0	standard	0	without
1	max. length ³⁾	1	Slideline SLXX	2	Guide Carriage Slideline SLXX	1	Cable channel	X	SFI 0.1 mm
2	variable stop complete VS soft left only for Starline, KF and Heavy Duty guide		Slideline with Activebrake SL-ABXX	3	Guide Carriage Slideline Activebrake SL-ABXX	2	Cable channel two-sided	Y	SFI 1 mm
3	variable stop complete VS hard left only for Starline, KF and Heavy Duty guide		Slideline with Passivebrake Multibrake SL-MBXX	4	Guide Carriage Slideline with Passivebrake Multibrake SL-MB	X	without Cover rail		
4	variable stop complete VS soft right only for Starline, KF and Heavy Duty guide		Proline PLXX	6	Guide Carriage Proline PLXX				
5	variable stop complete VS hard right only for Starline, KF and Heavy Duty guide		Proline with Activebrake PL-ABXX	7	Guide Carriage Proline Activebrake PL-ABXX				
6	variable stop complete VS soft both sides only for Starline, KF and Heavy Duty guide		Proline with Passivebrake Multibrake PL-MBXX	8	Guide Carriage Proline with Passivebrake Multibrake PL-MBXX				
7	variable stop complete VS hard both sides only for Starline, KF and Heavy Duty guide		Activebrake ABXX	B	Guide Carriage Starline STLXX				
			Starline STLXX	C	Guide Carriage KFXX				
			KFXX	D	Guide Carriage Heavy Duty HDXX				
			Heavy Duty HDXX	E	Guide Carriage Powerslide PSXX/25				
			PSXX/25 Powerslide	F	Guide Carriage Powerslide PSXX/35				
			PSXX/35 Powerslide	G	Guide Carriage Powerslide PSXX/44				
			PSXX/44 Powerslide	H	Guide Carriage Powerslide PSXX/60				
			PSXX/60 Powerslide	I	Guide Carriage Powerslide PSXX/76				
			PSXX/76 Powerslide	M	Guide Carriage Slideline with Passivebrake Multibrake SL-MBXX without brake function				
			Inversion	N	Guide Carriage Proline with Passivebrake Multibrake PL-MBXX without brake function				
			Duplex						



Parker Worldwide

Europe, Middle East, Africa

AE – United Arab Emirates, Dubai
Tel: +971 4 8127100
parker.me@parker.com

AT – Austria, Wiener Neustadt
Tel: +43 (0)2622 23501-0
parker.austria@parker.com

AT – Eastern Europe, Wiener Neustadt
Tel: +43 (0)2622 23501 900
parker.easteurope@parker.com

AZ – Azerbaijan, Baku
Tel: +994 50 2233 458
parker.azerbaijan@parker.com

BE/LU – Belgium, Nivelles
Tel: +32 (0)67 280 900
parker.belgium@parker.com

BG – Bulgaria, Sofia
Tel: +359 2 980 1344
parker.bulgaria@parker.com

BY – Belarus, Minsk
Tel: +48 (0)22 573 24 00
parker.poland@parker.com

CH – Switzerland, Etoy
Tel: +41 (0)21 821 87 00
parker.switzerland@parker.com

CZ – Czech Republic, Klecany
Tel: +420 284 083 111
parker.czechrepublic@parker.com

DE – Germany, Kaarst
Tel: +49 (0)2131 4016 0
parker.germany@parker.com

DK – Denmark, Ballerup
Tel: +45 43 56 04 00
parker.denmark@parker.com

ES – Spain, Madrid
Tel: +34 902 330 001
parker.spain@parker.com

FI – Finland, Vantaa
Tel: +358 (0)20 753 2500
parker.finland@parker.com

FR – France, Contamine s/Arve
Tel: +33 (0)4 50 25 80 25
parker.france@parker.com

GR – Greece, Athens
Tel: +30 210 933 6450
parker.greece@parker.com

HU – Hungary, Budaörs
Tel: +36 23 885 470
parker.hungary@parker.com

IE – Ireland, Dublin
Tel: +353 (0)1 466 6370
parker.ireland@parker.com

IL – Israel
Tel: +39 02 45 19 21
parker.israel@parker.com

IT – Italy, Corsico (MI)
Tel: +39 02 45 19 21
parker.italy@parker.com

KZ – Kazakhstan, Almaty
Tel: +7 7273 561 000
parker.easteurope@parker.com

NL – The Netherlands, Oldenzaal
Tel: +31 (0)541 585 000
parker.nl@parker.com

NO – Norway, Asker
Tel: +47 66 75 34 00
parker.norway@parker.com

PL – Poland, Warsaw
Tel: +48 (0)22 573 24 00
parker.poland@parker.com

PT – Portugal
Tel: +351 22 999 7360
parker.portugal@parker.com

RO – Romania, Bucharest
Tel: +40 21 252 1382
parker.romania@parker.com

RU – Russia, Moscow
Tel: +7 495 645-2156
parker.russia@parker.com

SE – Sweden, Spånga
Tel: +46 (0)8 59 79 50 00
parker.sweden@parker.com

SL – Slovenia, Novo Mesto
Tel: +386 7 337 6650
parker.slovenia@parker.com

TR – Turkey, Istanbul
Tel: +90 216 4997081
parker.turkey@parker.com

UA – Ukraine, Kiev
Tel: +48 (0)22 573 24 00
parker.poland@parker.com

UK – United Kingdom, Warwick
Tel: +44 (0)1926 317 878
parker.uk@parker.com

ZA – South Africa, Kempton Park
Tel: +27 (0)11 961 0700
parker.southafrica@parker.com

North America

CA – Canada, Milton, Ontario
Tel: +1 905 693 3000

US – USA, Cleveland
Tel: +1 216 896 3000

Asia Pacific

AU – Australia, Castle Hill
Tel: +61 (0)2-9634 7777

CN – China, Shanghai
Tel: +86 21 2899 5000

HK – Hong Kong
Tel: +852 2428 8008

IN – India, Mumbai
Tel: +91 22 6513 7081-85

JP – Japan, Tokyo
Tel: +81 (0)3 6408 3901

KR – South Korea, Seoul
Tel: +82 2 559 0400

MY – Malaysia, Shah Alam
Tel: +60 3 7849 0800

NZ – New Zealand, Mt Wellington
Tel: +64 9 574 1744

SG – Singapore
Tel: +65 6887 6300

TH – Thailand, Bangkok
Tel: +662 186 7000

TW – Taiwan, Taipei
Tel: +886 2 2298 8987

South America

AR – Argentina, Buenos Aires
Tel: +54 3327 44 4129

BR – Brazil, Sao Jose dos Campos
Tel: +55 800 727 5374

CL – Chile, Santiago
Tel: +56 2 623 1216

MX – Mexico, Toluca
Tel: +52 72 2275 4200

European Product Information Centre

Free phone: 00 800 27 27 5374

(from AT, BE, CH, CZ, DE, DK, EE, ES, FI, FR, IE, IL, IS, IT, LU, MT, NL, NO, PL, PT, RU, SE, SK, UK, ZA)

© 2016 Parker Hannifin Corporation. All rights reserved.

PDE2690TGUUK - V4 - May 2016



Parker Hannifin Ltd.

Tachbrook Park Drive
Tachbrook Park,
Warwick, CV34 6TU
United Kingdom
Tel.: +44 (0) 1926 317 878
Fax: +44 (0) 1926 317 855
parker.uk@parker.com
www.parker.com

Your local authorized Parker distributor