

# Print Finishing and Converting

## ‘M’ Scheme Syllabus



By,  
**G.Venkateswaran, Lecturer (SS)**  
**N.Sivaraman, Lecturer (SS)**



**Department of Printing Technology**  
**Arasan Ganesan Polytechnic College, Sivakasi**

## Unit - I                      Binding and Finishing - Introduction

### 1.1 – Brief Introduction to Print Finishing.

The meaning of binding is to fasten or to attach together. The main purpose of binding is to keep the leaves of a book in order to protect them.

The term “Finishing Processes” is applied to binding. The term binding is not sufficient to express all the processes; hence the modern term “*finishing*” is more proper and suitable.

### 1.2 Classification of Book Binding – Quarter bound book, Half bound book – old style and new style, Full bound book.

The covering material is the first part of the book to be seen by the user and it should make a good impact. The appearance of the book varies and depends upon the material used for covering of the book.

The main three styles of covering are

- (i) Quarter bound
- (ii) Half bound
- (iii) Full bound

#### Quarter bound book



When only the spine edge of the book is covered with calcio and rest with marble paper then it is called as quarter bound book. It is the cheapest and mostly “cut-flush” method is used. It can also be done as turned-in, i.e. the book is trimmed after attaching boards and then the covering material is turned-in. It is also called as quarter bound all-sides-turned-in (ASTI).

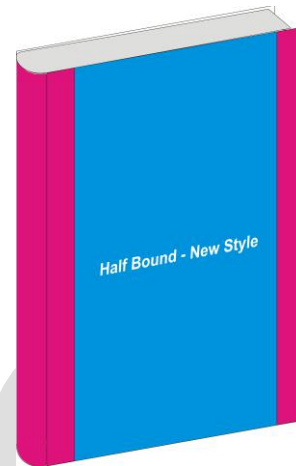

When the spine edge and fore-edges are covered with calico cloth and the remaining areas are covered with marble paper, it is called as half bound book. There are two kinds of half bound book. They are

- (i) Half Bound – Old Style
- (ii) Half Bound – New Style

**Half Bound – Old Style**

If the spine edge and the fore edge corners of the board are covered with calico and the remaining areas are covered with marble paper, it is called as half bound old style.

**Half Bound – New Style**

If the spine edge and the complete fore-edge of the board are covered with calico and the remaining areas are covered with marble paper, it is called as half bound new style.

**Full bound book**



When the book is fully covered-up with only or completely calico cloth, it is called as full bound book.

### 1.3 - End Paper – Types and its use - Single End Paper, Made End Paper, Reinforced End Paper, Cloth Joint End Paper, Zig Zag End paper.

#### Purpose of the end paper

1. The end paper is a media in between the book and the covering material. It forms an inner joint in between book and cover.
2. The fly leaves of the end paper protect the first and last pages of the book. It also prevents the first and last pages from bad handling, stains etc.
3. It gives first good appearance as it helps to hide the constructional features of the covering. The board-sheet is pasted over the board.
4. The pasting of the end paper on board assists in counter-acting the outward warp of the board caused by the covering.

#### Types of end papers

1. Single end paper
2. Reinforced end paper
3. Cloth joint end paper
4. Made end paper
5. Zig zag end paper

#### Single end paper

### Single End Paper

• Full Sheet - 1No.

This type of end paper is common and is used inside stitched books. It is the cheapest variety of end paper ( Blank paper, Kraft paper, Color paper or chart paper). It consists of two single leaves, one to cover the constructional features called the board leaf and the other one is the fly leaf. For making this end paper single sheet of same length and double in width of the book is needed. The end paper is made by just folding it into half.

### Reinforced End Paper

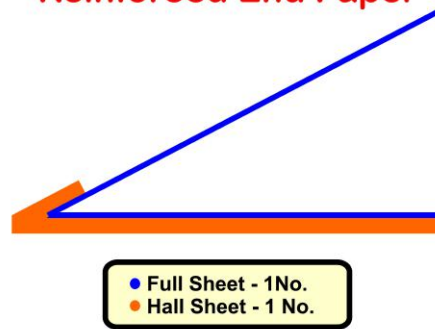

In this kind of end paper the fly leaf is stiffened by positioning a half sheet over it (A half sheet is slightly larger than the book width). Then excess width is turned and pasted over the full sheet which is equal to the length of the book to be bound but double in its width than the book's width.

### Cloth-joint end paper

#### Cloth-joint End Paper

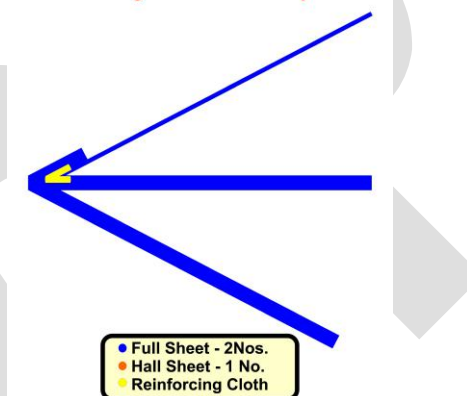

In this kind of end paper the fly leaf needs two full sheets and a half sheet. A strip of calico is pasted over the center fold. The two full sheets are pasted as shown in the picture. Then the half sheet is pasted over the full sheets to hide the reinforcing cloth material.

### Made end paper

#### Made End Paper

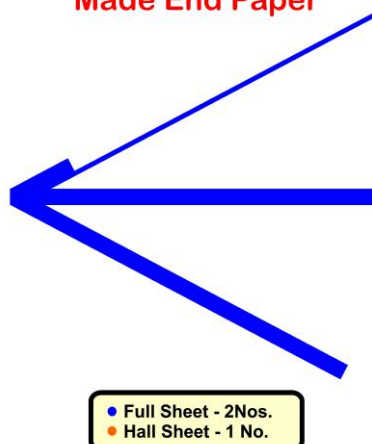

For preparing made end paper we need two full sheets and one half sheet. This end paper is similar to cloth joint end paper but the only difference is we are not using any reinforcing cloth here. The two full sheets are pasted as shown in the picture. Then the half sheet is pasted over the full sheets to give the final reinforcement.

### Zig Zag end paper

Zig-zag End Paper

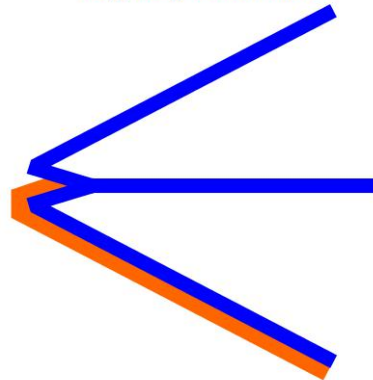

- Full Sheet - 2Nos.
- Half Sheet - 1 No.
- Zig Zag Sheet - 1 No.

For preparing this end paper we need two full sheets, one half sheet and one zig zag sheet. It is rarely used and especially used in heavy books having large number of pages. The two full sheets are pasted by just leaving a portion un-pasted at the spine side. Now the zig zag sheet is pasted over these pasted full sheets. After that we have to paste the half sheet.

### 1.4 Binding and Finishing Tools

#### Folder

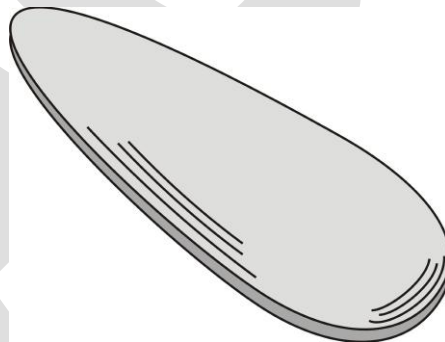

It is used for folding the papers, smoothing down the pasted paper or cloth. It is made of wood, bone or plastic.

#### Needle



The needle must be long and strong, with big eyes to take the thread freely. They must be non rusty, preferably made of steel. It is used for sewing the book.

### Tenon Saw



The tenon saw is used to make groves in the back folds of the sections for sewing. It is a saw with thin blade, long steel back and small teeth with a wooden handle.

### Bodkin

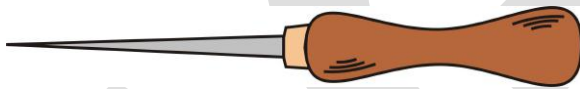

Bodkin is a fine thin pointed shaft with metal or wooden handle. It is used for piercing holes in paper and boards. It is mainly used in side sewing.

### Piercer/Awl



An awl is a small pointed tool used for piercing holes, especially in leather. It is also used for piercing holes on sections of the book for centre stitching or sewing.

### Eyelet Punch



Eyelet punch is a machine used for punching eyelet holes and fastening eyelets in paper, board or cloth.

### Brushes



Glue brushes are round with stiff and short hairs. Paste brushes have long hairs and are flat and wide. The brushes must be of best quality.

### Hammer

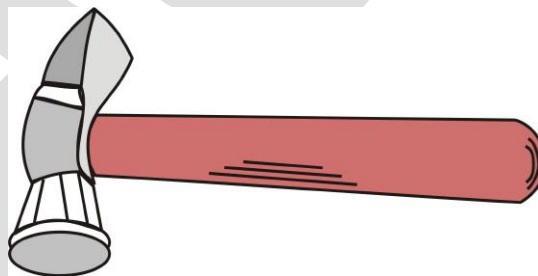

The binder's hammer is used for many operations like knocking out the grooves. Reducing the swell, rounding and backing etc.

### Scale





The scale rule with graduations in inches, centimeters and millimeters are used in various stages of forwarding for measuring.

### **Carpenter's "L" Square**



It is the most essential tool to check the squareness of the board's trimmed books etc.

### **Scissors**

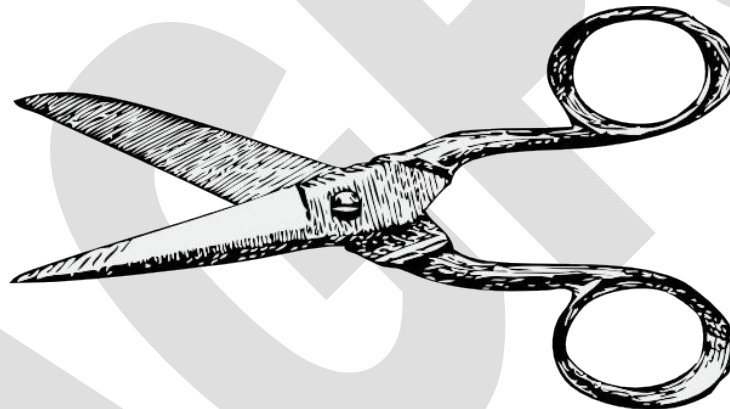

It is tailor type large scissors used for cutting textile covering materials.

### **Binder's knife**



It is a long wide, thin blade with wooden handle used for cutting miscellaneous papers.

### **Spring Divider**

Dividers are instruments used for measuring distances between two points, transferring or comparing measurements directly from a rule, or for scribing an arc, radius, or circle.

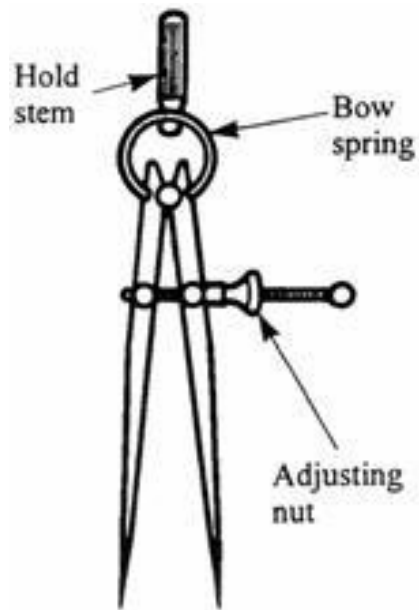

## 2. Finishing Tools

To carry out the finishing operations like gilding, tooling, blocking many tools are used.

### Type Holder

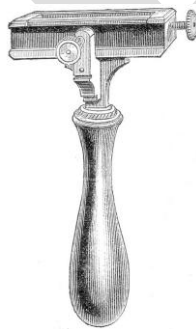

Brass types are assembled into a hand held type holder. It is very useful in blocking on the spine side of the book.

### Fillet

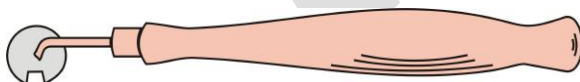

These are round discs of brass with metal shaft and wooden handle. On the edges of the periphery of disk, single, double or triple lines are engraved in relief. These are used to block squares with angled corners.

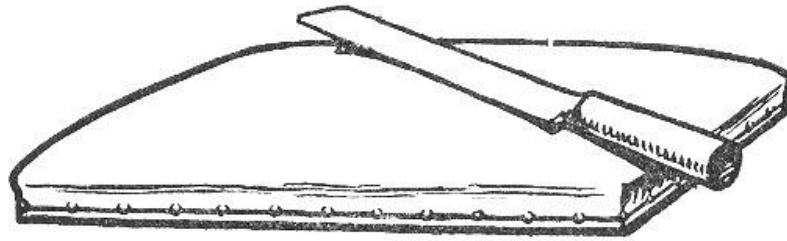

A wooden board covered with leather and is used for cutting the gold leaf or foil.

### Finishing Stove

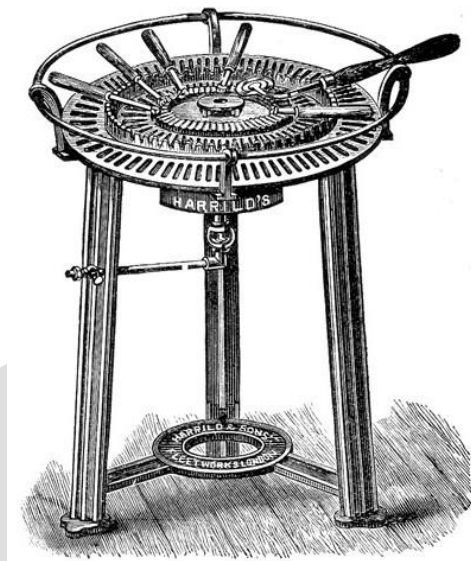

The finishing stove has a wider stand so that many tools can be placed for heating purpose at a time.

### Lamination

Lamination is the process of combining together two or more plies of the same or different substrate to form a single complex material with considerably improved characteristics. The normally used combinations are:

- a. Plastic and aluminum
- b. Plastic and board
- c. Plastic and paper

There are four types of lamination

1. Dry lamination
3. Wet lamination
4. Thermal lamination

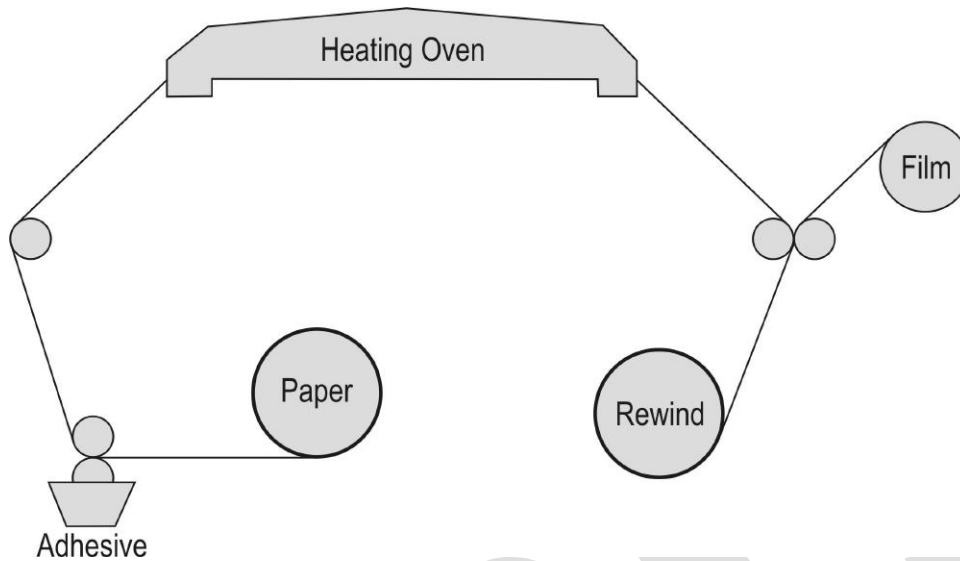

This lamination is usually done by dry bonding technique using a resin and solvent-based adhesive. Here the cellulose film is coated with polymer on one side and the resin is applied to the uncoated side. The film is combined together by pressing between two rollers. Then it is cooled and rewound as a roll.

## 2) Wet lamination

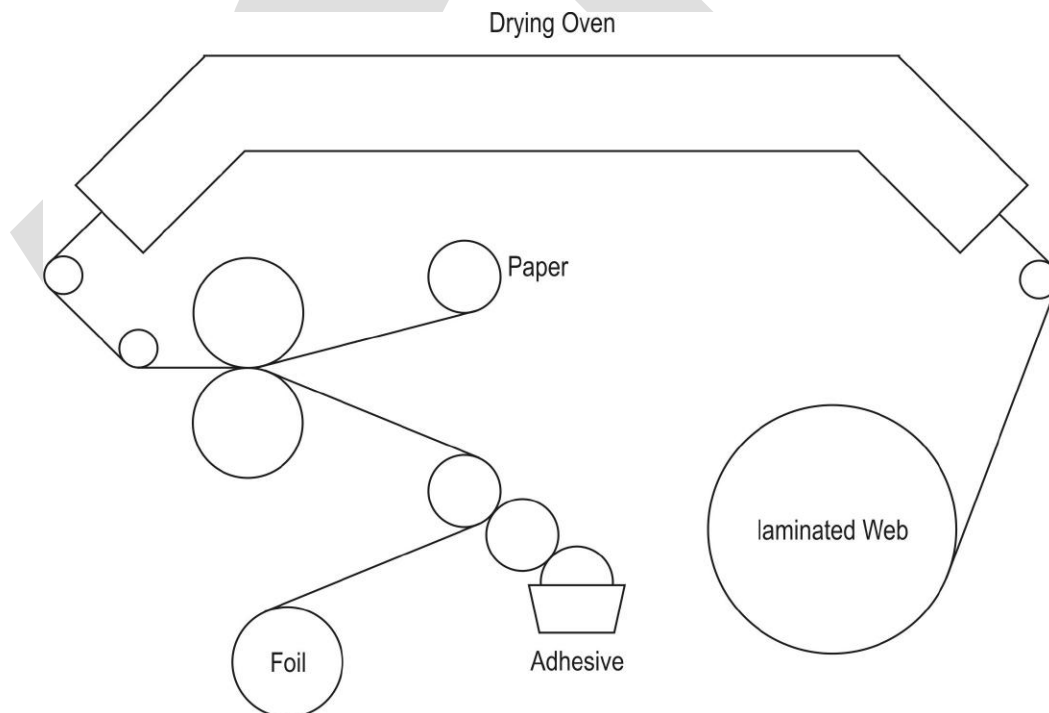

Here paper and foil is laminated together by wet bonding technique. The foil is coated on one side with adhesive and passed through nip rollers. In the nip rollers the paper joins with the foil. The laminated web passes through a drying oven, where the adhesive is dried and then rewound as a roll.

## 3) Thermal lamination

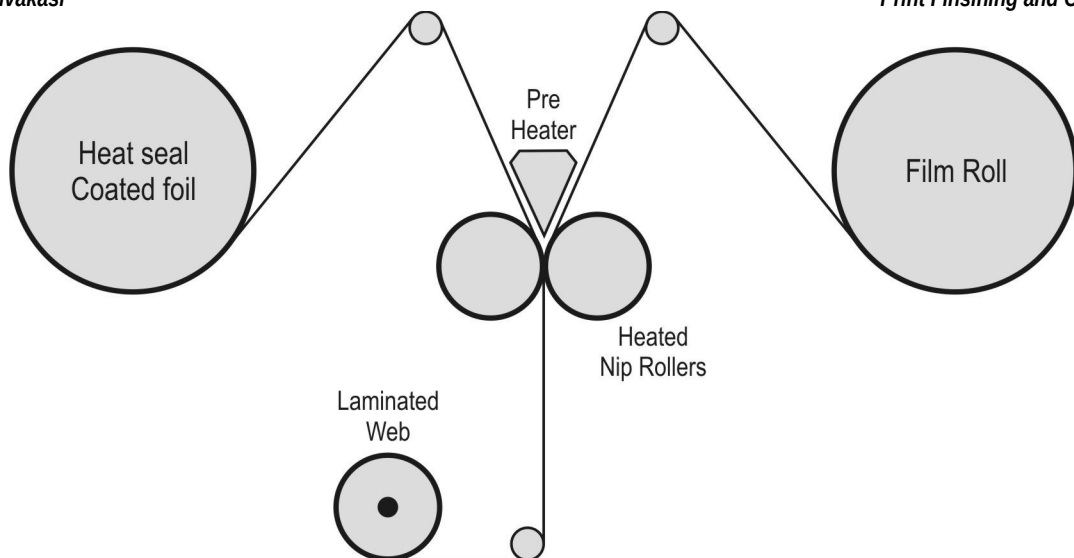

Polymer coated films are laminated together by this process. The two substrates were individually heated by a pre-heater and passed between heated nip rollers. Due to heat and pressure the films adhere together and the laminated web is rewound as a roll.

### Window Lamination

Window lamination is mainly used in food packaging. It provides visibility, transparency and protection. It also provides luxury high gloss and protection to the complete packaging box. Window lamination is also an economical one.

Window lamination can be applied both internally and externally to any pack and has a number of benefits over more traditional style window patching.

When applied internally the film creates a food safe barrier between the board and product so eliminating the need for bags, PE board or window patching. When applied externally the film decoratively enhances the pack and gives added protection to both product and packaging.

### Benefits:

- Reduces Packaging Waste
- Visually Enhances Product
- Decoratively Enhances Pack
- Protective Barrier between Food & Packaging eliminating need for bags/PE board
- Provides Strength & Durability
- 100% Recyclable or Reclaimable
- Added Security

### Strip Lamination

Strip Lamination is the combination which creates a pack with the practicality of film and the tactile qualities of paper.

## 1.5 Varnishing

Varnishing is a transparent, hard, protective finish or film that is applied to a printed surface to add a clear glossy attractive appearance. Varnish is available in matte, dull or gloss and can be applied on the entire press sheet or in selected areas.

### Full Sheet Varnishing



If the entire surface of the sheet or board is varnished, then it is called as full sheet varnishing.

### Spot or Patch Varnishing



If the required area (or) the printed area is applied with varnish, then it is called as spot or patch varnishing.

### Gloss varnish

Gloss varnish brings out the colors in a printing. Gloss varnish is normally used as a spot varnish to highlight images or photographs printed on an uncoated paper.

### Matt varnish

Matt varnish is normally preferred to avoid glare due to reflection but the colors appear duller in a matt varnish.

### Aqueous varnish



Low cost water based aqueous coatings are most commonly used today. They provide **good protection** from finger prints and other blemishes. Like varnishes aqueous coatings are applied **in-line** on the press but the aqueous coatings are **shiner** and **smoother** than varnish. They also have higher **absorption** and **rub resistance**. They are less likely to yellow and **environment friendly**. They **dry faster** than varnish.

### Solvent based Varnish

Solvent-based varnishes are based on synthetic resins dissolved in petroleum solvents. After application the film-forming substances in varnishes harden due to evaporation of solvent.

### UV (Ultra Violet) Coating



Extremely high gloss UV, or Ultra Violet, coating offers more protection than varnish and aqueous coating. UV varnishing is applied as liquid, using a roller, a screen or a blanket and then exposed to UV light. The UV light polymerizes and hardens the coating. UV varnish is glossier than all other varnishes. It offers best rub protection but it is costlier than all other varnishes.

### Special Effect Varnishes

The use of varnishes for special effects is not limited merely to surface effects. Unusual designs can be achieved with inked varnishes. The best examples for special effect varnishing are pearlescent varnishing, metallic varnishing etc.

With the help of screen printing we can apply thick coating of varnish. We can feel the relief of the coating with our fingers. Special relief codes, such as Braille lettering or security features in security papers, can be created in this way. Embossed wallpapers are prepared using special effect varnishes with relief effect.

Apart from visual effects, special effect varnish can be used to stimulate the sense of smell. Scented varnishes are used for this purpose. Micro-encapsulated fragrances are embedded in the varnish. When the printed varnish is rubbed, the micro capsules burst and the fragrance is released.



## **2.1 – Ware House, Types of Ware House – White paper Ware House, Printed paper Ware House**

The warehouse is the place of practice where a printed and blank stock is handled to convert into finished product. There are two types of warehouse in nature

- (1) White paper warehouse      (2) Printed paper warehouse

### **White Paper Ware House**

In this ware house only the unprinted sheets are stored and handled. From this ware house the paper goes to the printing press department for printing.

### **Printed paper Ware House**

In this ware house only the printed sheets are stored and handled. After printing the printed sheets from the printing press department comes here for storing before it goes to the binding and finishing department.

## **2.2 – Covering Materials – Binding cloth, Buckram cloth, Rexene, Leather, Paper fabric, PVC**

### **Binding Cloth**

It is a very important material in book binding. It is used to cover the book and make it attractive, to reinforce spine edge of the book, to hold the straw boards with the book spine.

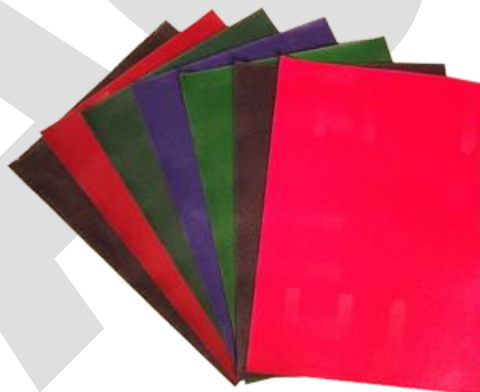

It is a closely woven cloth from good quality cotton fabrics. It is starched on one side. It is available in many colors but red, green and blue are popular. The gaps between the woven threads are filled up with pigment filler and finally heavily starched on one side. It prevents the penetration of glue from rough side to polished side.

### **Buckram Cloth**



It is superior quality binding cloth. It is closely woven and stiffened with heavy paste and glazed to avoid finger prints on cloth. Sometimes it is grained and embossed with different patterns to make the appearance attractive.

### Rexene



The closely woven cloth is coated with cellulose plastic. Due to this the Rexene becomes water and stain resistant. It is very strong and durable. Various attractive patterns are embossed on it. It is used for cheap account books, diaries, albums etc.

### Leather

Leather is a very durable covering material but also very costly. Leather is used in costly and durable bindings only. Mainly account books, ledgers and very rare valuable books are bound in leather.

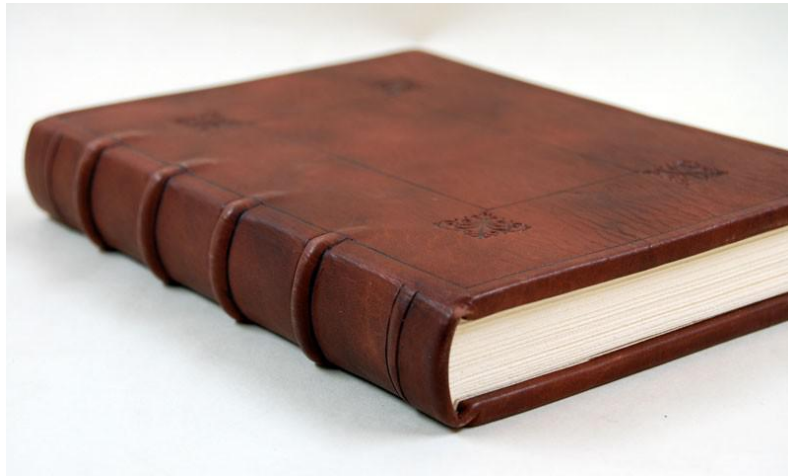

Leather is durable covering material but also very costly. It is very attractive and pleasant to handle. Mainly account books, ledgers and very rare valuable, costly books are bound in leather. Leather bound books are mostly decorated by gold blocking etc. leather is of mainly two varieties. They are skins and hides.

Skin means leather obtained from the small animals such as goat, sheep, calf and pig. Hide means the leather prepared from matured animals such as bullock, cow etc.

### **Paper Fabric**



It can be called imitation book cloth. Paper fabric is a strong paper made from chemical wood pulp highly sized and grained. It has high tensile strength but does not have resistant to water and stain. It is used in very cheap quality binding e.g. exercise note books.

### **PVC**



Here the closely woven cloth is coated with **Poly Vinyl Chloride**. It is not so durable. It is available in many colors and patterns. It is used for diaries and pass books.

### **2.3 – Reinforcing Materials – Mull Cloth, Calico Cloth, Tapes and Cords**

#### **Mull Cloth**



It is loosely woven cotton cloth, heavily starched and stiffened. It is called as a reinforcing material because it gives additional strength, support to the spine of the book when it is affixed over the glued spine as first lining. This cloth is also used for strengthening the end paper.

#### **Calico Cloth**

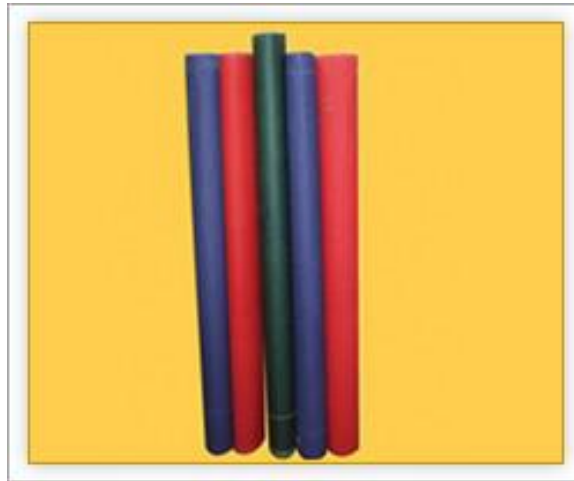

It is as good as mull cloth but closely woven, lightly starched and is made from bleached cotton. It is superior to mull cloth and used like mull cloth but in superior quality books.

### Tapes



Cloth tape is used for sewing books. It may be 1.27cm in width and its length is according to the thickness of the book. Linen tape is very strong but at the same time nylon or terylene is the strongest.

### Cords



A good hemp cord is used for sewing purpose. Usually 3 to 5 ply hemp cord is used for sewing. Nowadays nylon cords are also available. It is obtained in balls.

## **2.4 – Securing Materials – Thread, Wire, Metal and Plastic Units**

### **Thread**

Sewing threads are manufactured from linen, cotton, nylon and terylene. Linen thread is expensive and most suitable for hand sewing.

### **Wire**

Stitching wire is made from low grade medium carbon steel in various grades. It is usually coated to prevent corrosion. It is mostly round but flat wire is also used.

### **Metal and Plastic Units**

Eyelets made from brass, steel or aluminium is used to prevent the tearing of hole in a paper or board. Rivets are used extensively in fastening of metal parts in paper products. Various types of metal and plastic fasteners such as spiral, comb, inter screw, rings, metal backs etc are used to hold loose sheets together.

## **2.5 – Adhesives – Paste, Glue, Synthetic Adhesive, Hot-melt, Gum**

### **Paste**

Paste is prepared from a mixture of plain flour, water, alum and formaldehyde. It is well mixed and heated on a pot until it is thickened. Formaldehyde is added as disinfectant. Paste is not water resistant, gets affected by humidity, bacteria, fungi and insects.

### **Glue**

Glue is prepared from the bones and skins of the animals by boiling with water. The first output is good quality, transparent “pearl glue”. The second output is “flexible glue”. The final output is of inferior quality, having bad smell and brown in color called as “scotch glue”. Glue named “cassava” has been recently introduced, which can be mixed with cold water and used.

### **Synthetic Adhesive**

These are made from (PVA) Poly Vinyl Acetate and are in white liquid form. These have good tackiness and high flexibility.

It is another synthetic adhesive made from copolymers, resins and waxes. It is 100% solid and is brought to working condition by melting is at 160° to 190° C

### **Gum**

It is obtained from tree. It is thin, nearly in liquid form with low viscosity. It is specifically used in manufacturing of envelopes, labels, stickers etc.

## **2.6 – Book Finishing Materials – Gold leaf, Blocking foil**

### **Gold Leaf**

It is solid in books of 25 leaves, the size being about 3 1/2 inch. Square. Gold leaf sticks to anything upon contact, unless the article is dry, clean and absolutely free from grease.

### **Blocking foil**

The blocking foil is made of aluminium, silver, brass metallic powders spread over waxed cellulose or polyester film carriers. The powder is finally covered with thin layer of tan (powder from oak). The foils are used for hand tooling, and blocking.

## Unit - III Forwarding Operations

### 3.1 – Cutting, Trimming, Difference between Cutting and Trimming, Folding – Types of Folding – Folding-to-paper, Folding-to-Print, Lump Folding.

#### Cutting

Cutting is defined as bringing the paper to the desired dimensions by cutting the pile of sheets in a cutting machine.

Normally cutting operation is performed in a single knife guillotine machine

#### Trimming

Trimming is the stage of the book production process in which the pages of a book are trimmed so that they have even edges. During this process the book is brought to its finished size. Trimming operation is carried out to trim away the unwanted paper from the head, tail and fore edge of the book

Trimming can be done either with the help of a three knife trimmer or with a single knife guillotine machine.

#### Difference between Cutting and Trimming

| Sl.No. | Cutting   | Trimming  |
|--------|---|---|
| 1.     | Cutting means bringing the paper to the required dimension.       | Trimming means bringing the book to the required size.                  |
| 2.     | Single knife guillotine is used for performing cutting operation. | Three knife trimmer is normally used for performing trimming operation. |
| 3.     | Cutting operation gives us the required size of sheets to us.     | Trimming operation produces unwanted waste paper.                       |

#### Folding

Folding is the process of preparing a section of a book or pamphlet by reducing its size according to the imposition scheme.

It is nothing but forming a permanent crease by crushing the fibres of the sheet at the line of folding.

There are three types of folding. They are

1. Folding-to-paper



2. Folding-to-print
3. Lump folding

### **Folding-to-paper**

Folding-to-paper means folding the paper to its edge to edge, particularly when the print area is in irregular shape.

#### **Requirements**

- Equal margins on opposite sides.
- Accurate size of the form.
- All sides must be in right angle.

#### **Advantages**

- Faster method of doing.

#### **Disadvantage**

- Quality is less.

### **Folding-to-print**

Folding-to-print means folding the paper exactly according to the print area. Particularly book work, magazines and quality controlled jobs are folded print-to-print with fine registration.

#### **Requirements**

- Run-on headings.
- Folding marks.
- Perfect imposition.
- Equal margin.

#### **Advantages**

- Quality is more.

#### **Disadvantage**

- Speed of work is slower.

### **Lump Folding**

Lump folding means folding collectively say 5-10 sheets at a time. After folding the individual sheets are separated. This is termed as “pulled”. After pulling or separating the sheets are finally pressed to have a crease.

Cheap quality book works are folded by this method. The quality will be less but the speed of the work is very fast.

### 3.2 – Creasing, Gathering, Collating, Binder’s/Collating mark, Inserting, Attaching of Plates and Maps.

#### Creasing

When thick material such as board is folded, its surface become damaged and ragged at the line of folding. In order to avoid such damage, creasing is done before folding operation.

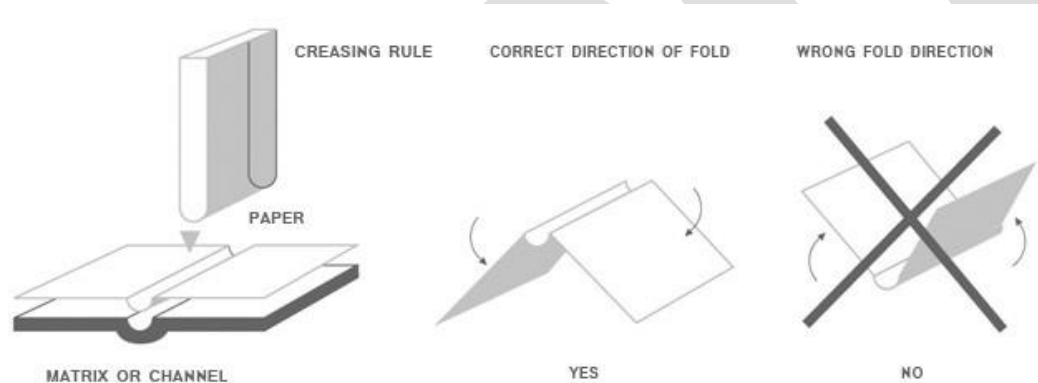

The creasing is done with the help of creasing rule, by giving a blind impression into the board so that the board can be folded without any damage.

#### Gathering

Gathering is the process of collecting all the sections of a book in a proper sequence. In manual gathering, all the sections of a book are stacked on a table in proper order. The binder will collect one section from each pile, beginning with the last signature.

Gathering must be done with utmost care to prevent mistakes.

#### Collating

Collating is the process of checking a gathered book to ensure that all the sections are there in proper order.

It is also known as “Examining” and must be done before the securing operation.

#### Binder’s/Collating mark

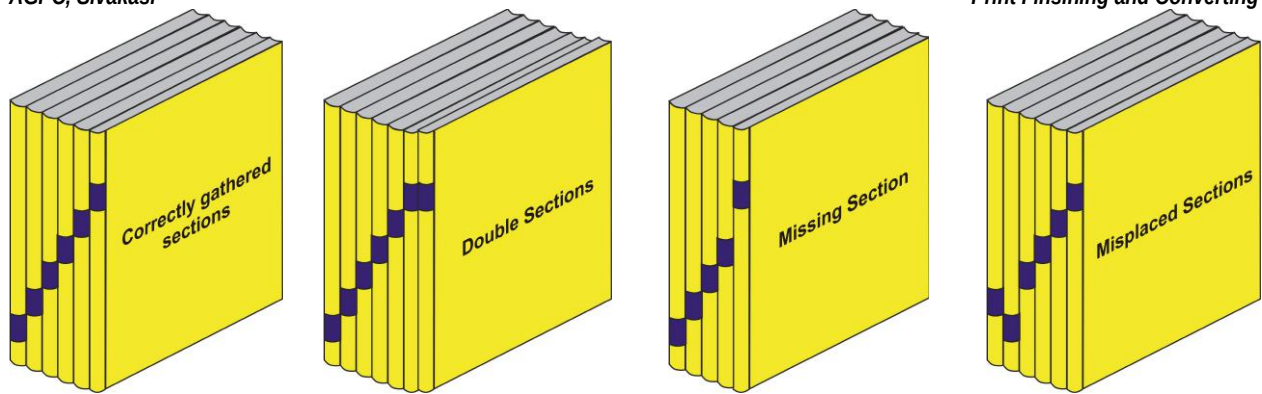

It is a black square mark printed on the spine of the each section. The marks are printed slightly offset in each section progressively. When the sections are correctly gathered the binder's mark on the spine side forms a step like appearance. By this we can identify the correctness of the gathering. It easily shows missed, extra, mis-placed sections.

### Inserting

When the paper used for printing the text is unsuitable for printing the halftone illustrations, they are printed on single leaves (coated paper) which are termed as **plates**. These plates are then inserted in appropriate places of a gathered book before sewing. Sometimes the single leaves are pasted after sewing. This operation is called as "**inserting**".

### Attaching plates or Maps

Sometimes folded maps or diagrams printed on a large sheet or board are also folded a little less than the book size and pasted inside the book. This is also called as "inserting" or "attaching plates or maps".

## 3.3 – Perforating – Types of Perforation, Punching and Drilling, Numbering – Horizontal Numbering and Vertical Numbering.

### Perforating

Perforating is defined as making a series of small holes very close to each other so that a portion of the sheet can be easily torn away.

There are three types of perforating. They are

1. Round Hole
2. Slot
3. Slit

Like punching machine, this has a male perforator bar and a female punch bar. The male bar has a number of small pins. When the treadle is pressed the pin pierces through the sheet and the female punch bar. In this way perforation is done.

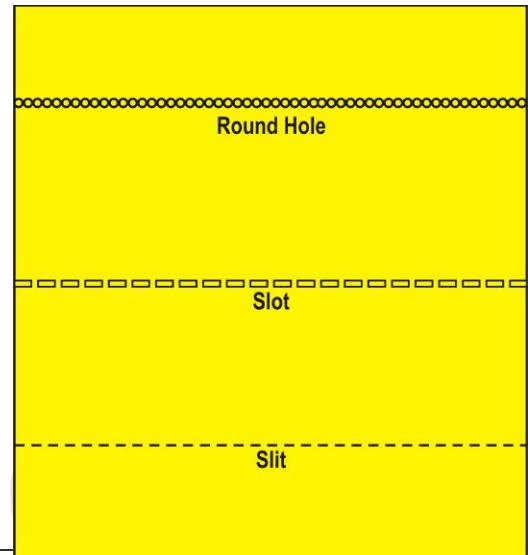

## Punching and drilling

### Punching

Punching is defined as making of one or more holes in the job in a determined position.

Punching is normally done in many shapes.

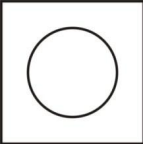
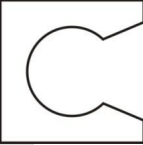
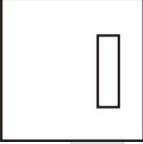
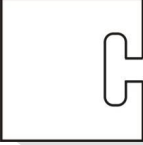
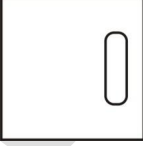
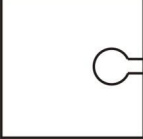
| SI.No. | Name          | Diagram   | Use   |
|--------|---------------|---|---|
| 1.     | Round Hole    |    | Interscrews, Ring binders, Endlock metals, Spiral binding etc., |
| 2.     | Key Hole      |   | Metal back ledgers.   |
| 3.     | Slot Holes    |  | Plastic com binders.  |
| 4.     | Thong         |  | Thong binder.   |
| 5.     | Blind         |  | Thong binder construction.                                      |
| 6.     | Slotted Round |  | Prong Binders.  |

Normally floor standing, foot operated or power operated punching machines are used. The punching machine has a male unit and a female unit. The sheets are placed in between the male and female unit. When the treadle is pressed, the male unit moves down and punches through the paper and the female unit at the bottom.

The number of sheets that can be punched at a time, depends upon the equality of the stock and the power of the machine. Depending upon the shape of the punch, the dies will be changed.

## Numbering

Most of the office stationary such as invoice book, duplicate pads, receipt books, tickets and account books, require numbering either serially, duplicate, triplicate, quadraplicate etc..

The hand numbering machine is a small handy machine. Impression is given by hand – pressure on handle. The machine can be adjusted to single, duplicate, triplicate etc..

But the position of hand numbering is not so accurate as it is done manually.

When the numbering is done horizontal to the sheet, then its is called as horizontal numbering. (e.g) currency notes and bill books. Normally horizontal numbering is preferred.

When the numbering is done vertical to the sheet, then its is called as vertical numbering.



## 3.4 – Die cutting and Slitting Operations.

### Die cutting

Die cutting is a process in which the materials are cut in a specific pattern. Die cutting is normally done on boards and papers. The pattern to be cut is prepared in a die using steel rules.

There are three types of steel rules used in a die. They are

- Cutting Rule
- Creasing Rule and
- Perforating Rule

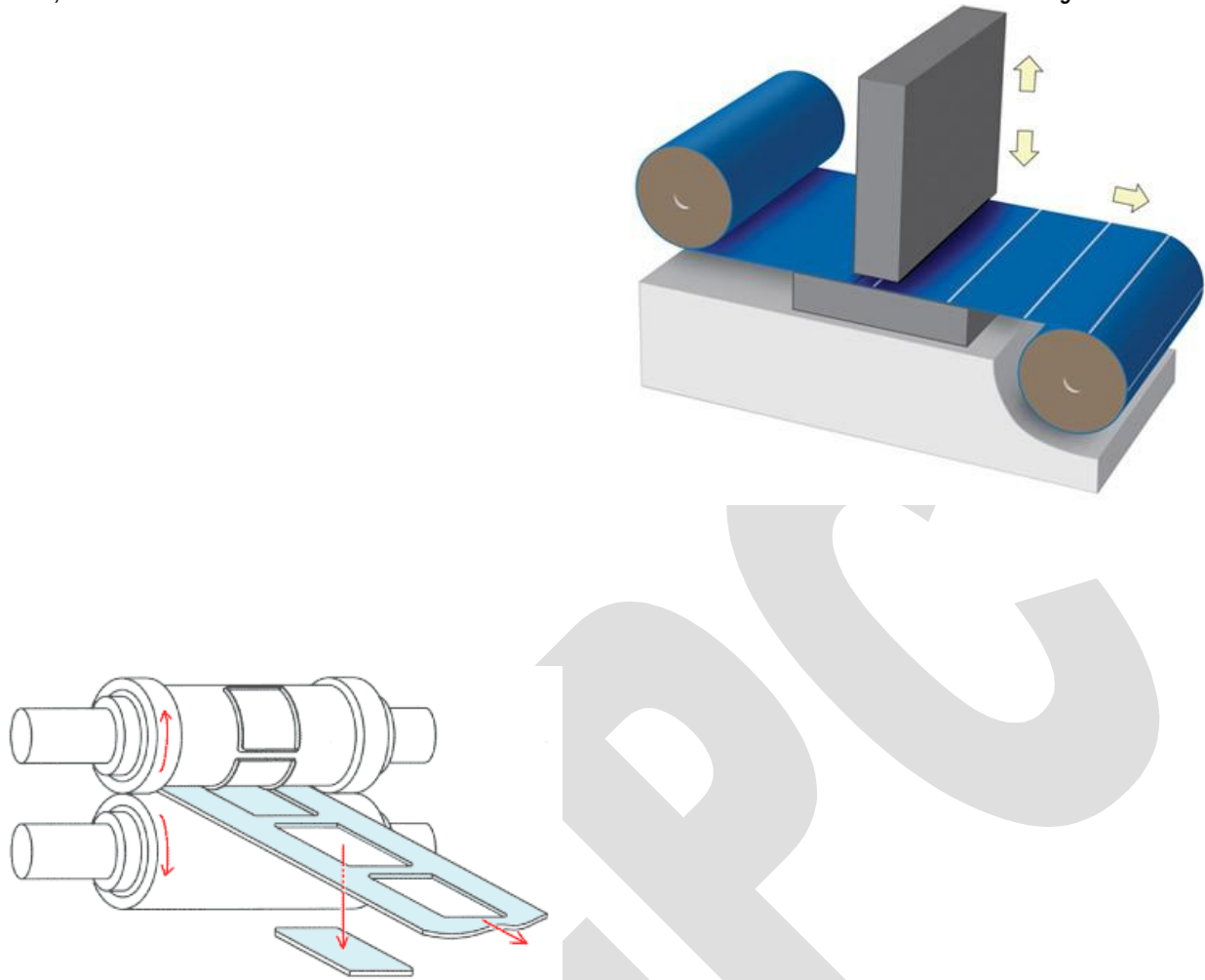

The male & female dies are prepared according to the job requirement and performed in a die cutting machine. Die cutting can be done in either a flat bed or rotary press.

Rotary presses perform the die cutting operation faster than flat bed presses but mostly flatbed die cutting is performed as the die making process is easier for flatbed die cutting presses.

### **Slitting**

Slitting is the process of dividing the reel of paper into two or more narrow ribbons with the help of rotary slitter wheels.

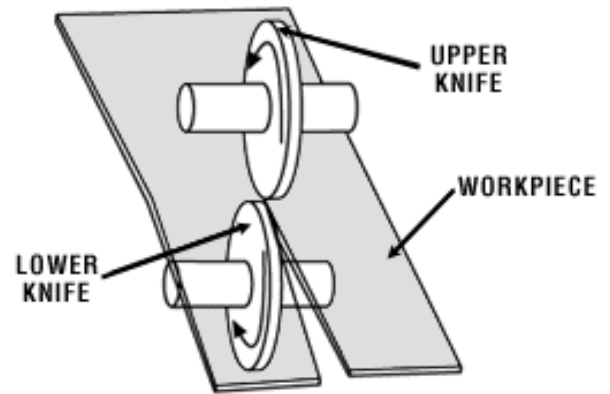
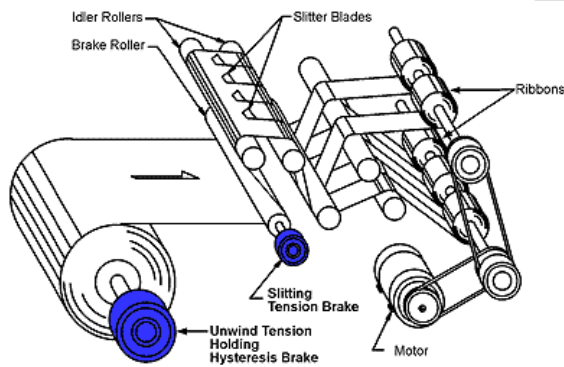
**SLITTING PROCESS**

Slitter wheels are sharp knives fixed on a rotating shaft. The sheet or reel that has to be slit into ribbons is fed between the slitter wheels. After passing through the slitter wheels, the reel is slit into narrow ribbons according to the number and position of slitter wheels.

### 3.5 – Headbands, Edge Decoration, Types of Edge Decoration – Coloring the edge, Marbling, Edge Guilding.

#### Head Bands

Head bands give strength to the head and tail to withstand strain on the book when pulled from a shelf.

There are two kinds of head bands.

1. Sewn-on (or) worked-on
2. Ready-made (or) machine-made

#### Advantages

- It gives a decorative effect.
- It protects the book from bad handling.
- It protects the edges of the book while handling from the shelves.

#### Sewn on Head Bands

A properly sewn headband gives strength and beauty to the book. Headbands are the foundation for the leather at the head and tail of a book. Headbands are nothing but embroidered silk threads worked round the strips of vellum (or) catgut (or) cord. The colors of the silk threads are normally selected to match the cover, edge decoration and end papers so that it will be very attractive.

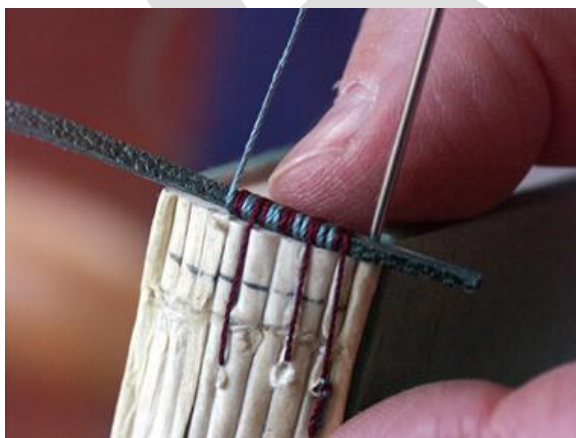



The sewn-on head bands are normally sewn with the help of two contrast color threads and directly on the head and tail sides of the book along with a cord or catgut. Since it is sewn with the book it gives good strength to the book at the head and tail.

### **Machine-made head bands**

These head bands are used only on costly work. These are ready-made with the help of a machine available in 12 yard length in different color combinations and six various widths. These headbands are available in cotton or silk.



These headbands are attached to the book by just gluing. So it will not give strength to the head and tail of the book. It just gives only attractiveness or adds beauty to the book.

### **Edge Decoration**

The three edges of the book other than the spine are decorated for the below mentioned reasons.

- Adds beauty and improves the appearance of the book.
- It protects the edges from bad handling, finger prints and stains.
- The dyes on the edges protect the book from dampness, direct sunlight and other atmospheric effects.
- It also prevents from dusting and changing the edges of paper into yellowish color.
- It protects the book from insects.

There are three methods of edge decoration. They are

1. Coloring the edges
2. Marbling the edges
3. Edge Gilding

### Coloring the edges



After trimming, the edges are colored by hand or by spraying the aniline and cosine dyes soluble in hot water. A little ox-gall and methylated spirit is added in color which helps to dry and spread the colors easily and quickly. Unwanted spots or stains can be removed off with oxalic acid. Various patterns of colors can be produced by spraying, stenciling, wax spotting etc. When thoroughly dried, a layer of clean wax is gently applied to the book edge.

### Marbling the edges



The book edge to be marbled is damped, washed with alum solution and dipped into a size of colors. To avoid air bubble, the edge of the book is descended into the size in an angled manner. This is not popularly used but it is used mainly in account book, If any fraudulent removal of a leaf is done, then it will be clearly visible in marbling.



Gilding the edges is nothing but the edges are gold colored. The edges of the book after trimming are scrapped and smoothed down with burnisher. The pores of the paper edges are filled with black lead filler using a wet cotton piece. Then glair (white of egg + vinegar) is applied over the edge. Finally gold leaf is applied over the edge. The leaf sticks to the edge because of wet glair, when thoroughly dried the leaf is peeled off. The gold powder deposits as a layer on the book edge.

**Unit - IV****Binding Operations****4.1 – Stitching – Side Stitching and Saddle Stitching.**

Stitching is classified as

- Side Stitching
- Saddle Stitching or Center Stitching

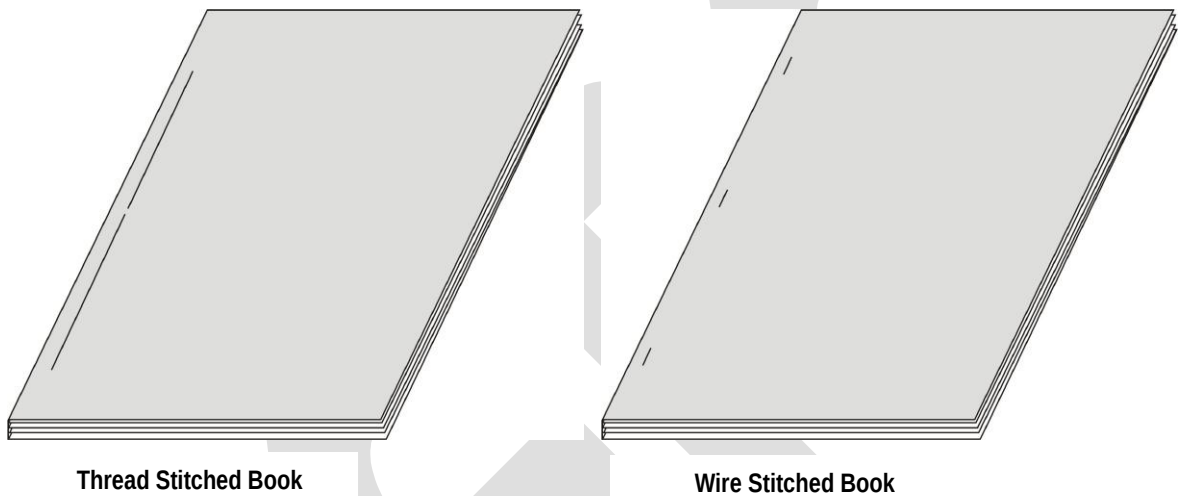
**Side Stitching**

When the sections are stitched using thread on the side of the book, then it is called side stitching.

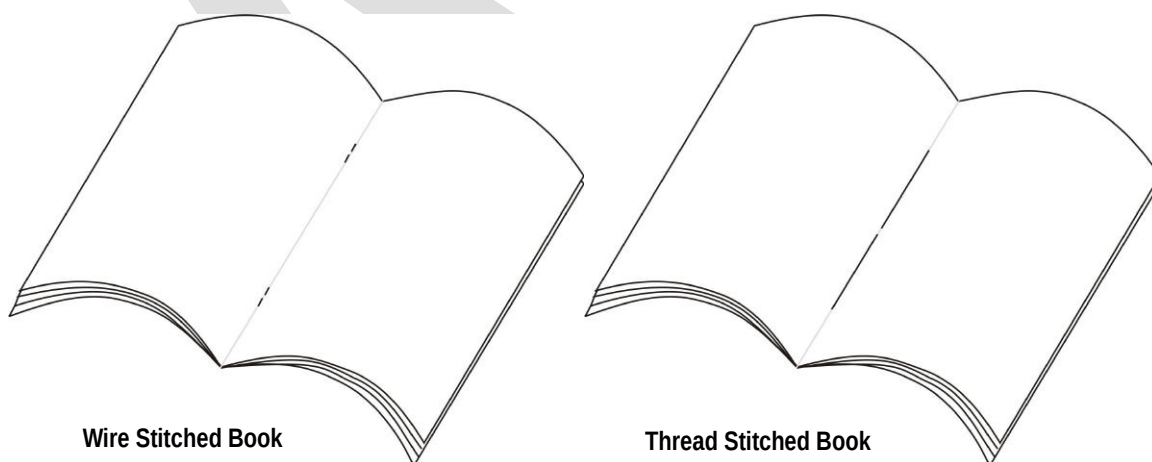
**Saddle Stitching**

When the sections are stitched using thread in the centre of the book, then it is called centre or saddle stitching.

**4.2 - Sewing, Types of Sewing – French Sewing, Tape Sewing or Sewing on Tapes, Raised Cord Sewing or Flexible Sewing, Recessed Card Sewing or Sawn-in Sewing, Two on & All along Sewing, Overcast Sewing.**

**French Sewing or Library Sewing**

The sections to be sewn are jogged well by knocking the head and spine of the sections on the table. The sections are held in between the plates of a nipping press. Saw cuts are made on the spine for making holes for sewing. The number of holes depends upon the length of the book to be sewn. The last section is sewn first and the first section is sewn last. In French sewing no reinforcing materials like tapes or cords are used.

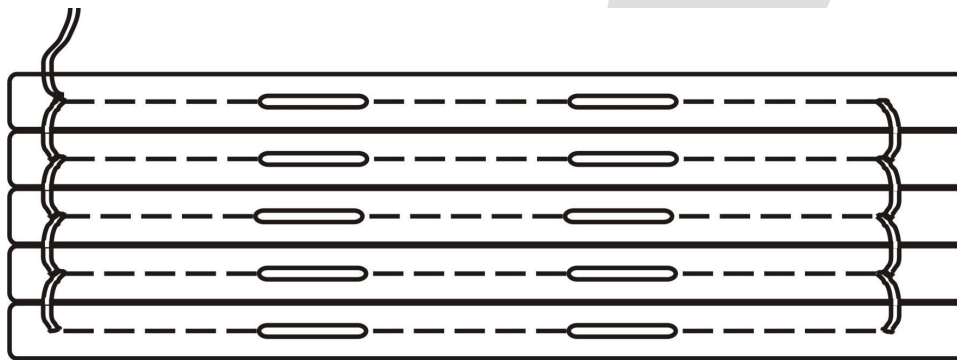

**Tape Sewing or Sewing on Tapes**

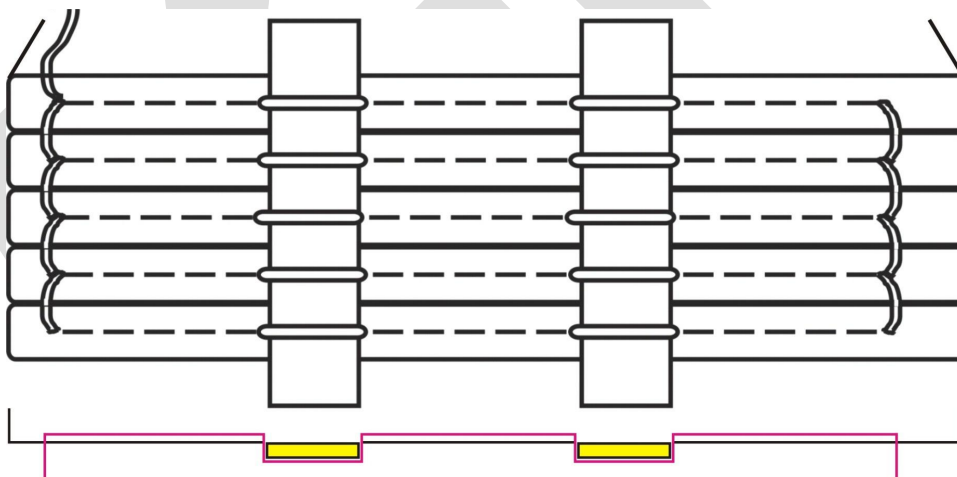

This is similar to French sewing but, tapes are used as a reinforcing material at the spine side. The number of tapes depends upon the length of the book. The position of the tapes and holes are marked using pencil. The thread passes over the tapes while sewing. Finally the tapes are attached to the end paper. This gives extra strength to the book and board. Account books and ledgers are sewn by this method.

### Raised Cord Sewing or Flexible Sewing

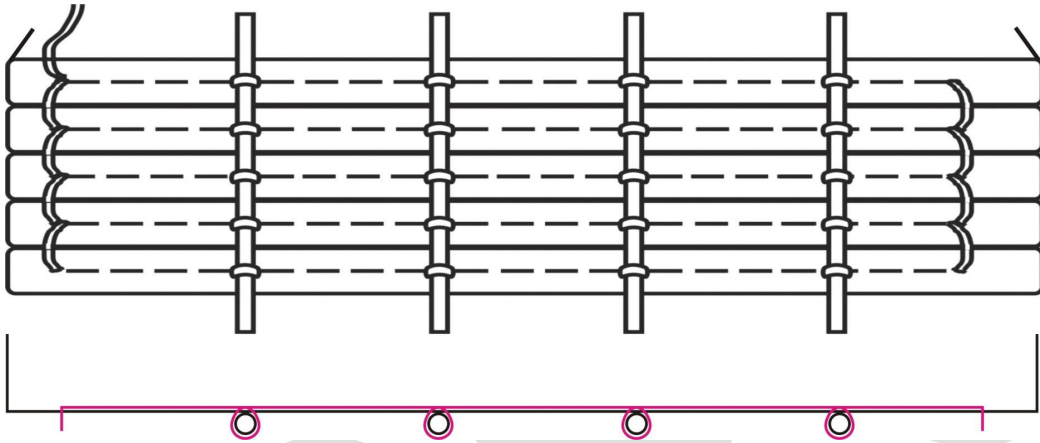

In raised cord sewing, instead of tapes, cords are used as the reinforcing material. This is similar to tape sewing but the thread encircles the cord while sewing. This gives a raised effect on the spine. The cords are spread and laced to the boards. This kind of sewing gives flexibility to the spine. Costlier books are sewn by this method. This is also called as flexible sewing.

## Recessed Cord Sewing or Sawn-in Sewing

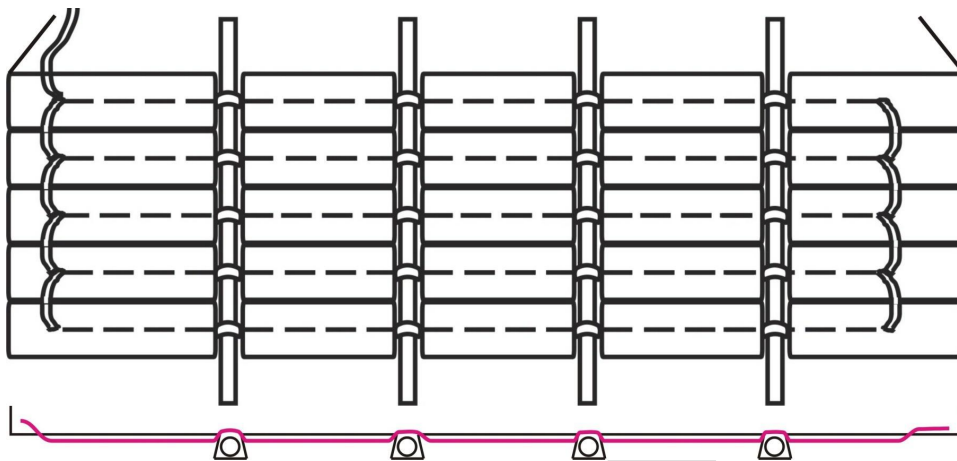

In recessed cord sewing grooves are made at the spine of the book for placing the cords. The cords are placed in the grooves while sewing. This avoids the raised effect of the cord on the spine. This sewing is also called as sawn-in sewing.

## Over cast Sewing

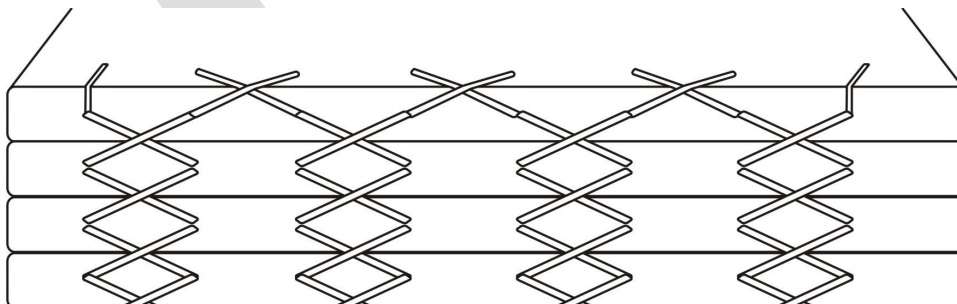



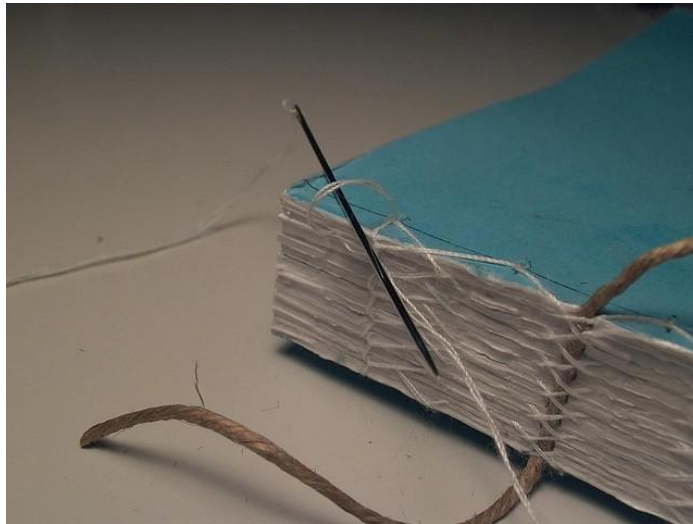

Loose sheets or the books with narrow margins are sewn by this method. The spine side is trimmed (in case of old books or uneven sheets) and glued. After drying, the book is separated into sections and sewn using thin thread and thin needles through the glued sections.

#### Two-on or All Along Sewing

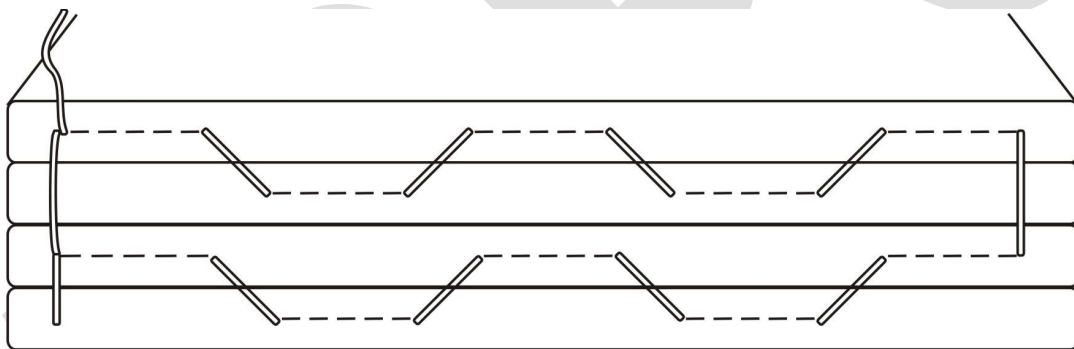

Thick book (i.e.) book containing more sections in bulk causes extra bulk on the spine due to threads. To avoid this bulk, two-on or all along sewing is used.

In this style, while the thread passes from one end to the other end (i.e.) from tail to head, it links two or three sections. Due to this the bulge caused by the thread in the spine is reduced. The production speed increases due to this type of sewing, but the strength is lost. Cheaper varieties of books are sewn by this method.

#### 4.3 - Loose Leaf Binding – Spiral Binding and Comb Binding

Loose-leaf binding is the most common form of stationary binding.

There are many kinds of loose-leaf binding. But three methods are most commonly used. They are:

- Spiral Binding
- Comb Binding

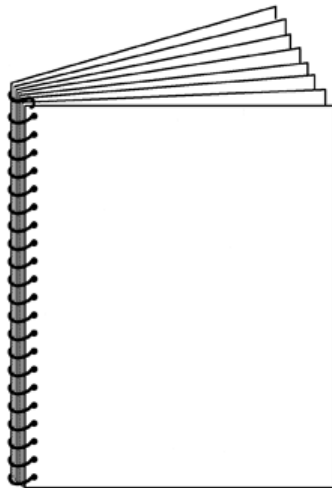

**SPIRAL BINDING**



A Spiral Binding consists of a continuous wire, which is coiled through evenly spaced holes that have been punched into the pages of a book. The spiral wire can be made of metal, plastic or plastic –coated metal. Plastic is available in verity of colors, but the metal spiral is not available in many colors.

When the books are open, the pages lie flat. The spiral binding is used for binding training manuals, cook books, note books and calendars.

### **Comb Binding**



**COMB BINDING**



This is a method of binding using plastic “comb” through rectangular holes in the paper. This type of binding allows book to open flat. This type of binding also allows addition or removal of pages from a book.

#### 4.4 - Perfect Binding – clamping station, milling station, gluing station, nipping station and delivery station.

##### Perfect Binding

Perfect binding is also known as **adhesive binding**. In this style of binding adhesive is used as the only securing material. A hot-melt adhesive is applied to the spine of the gathered pages. When the adhesive dries it securely bounds the book.

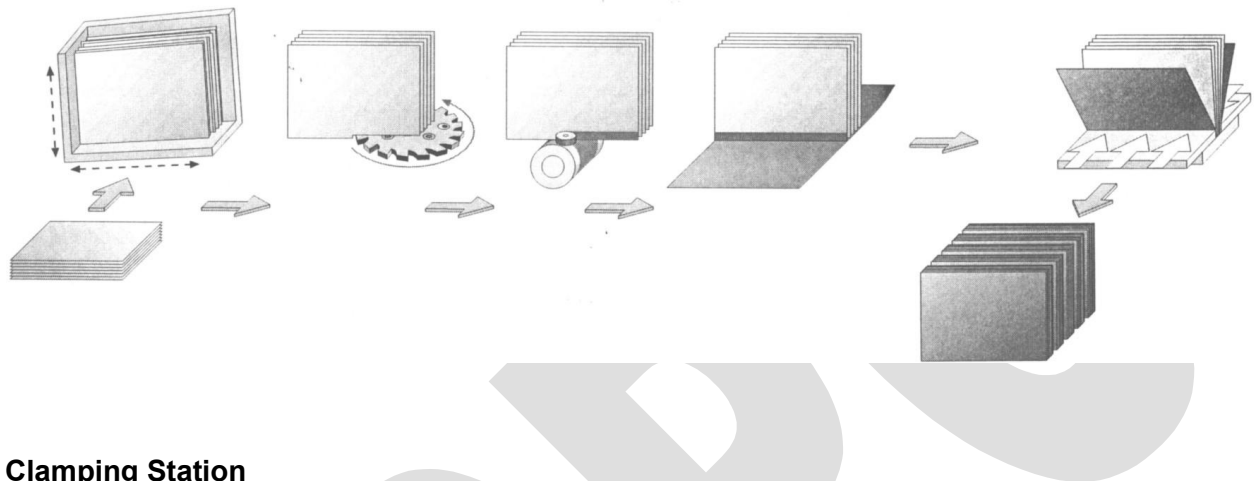

##### Clamping Station

The sections to be bound are clamped in the clamping station. The sections need to be jogged before clamping. The spine side of the sections is to be clamped downside in the clamp.

##### Milling Station

In the milling station, there is a rotary knife. The clamp takes the sections to the milling station. The rotary knife at the bottom mills the spine side of the sections. This enables the penetration of the glue completely into all the individual sheets of the sections.

##### Gluing Station

In the gluing station, there is a glue pot. Hot melt glue is melted in the glue pot. When the clamp takes the milled sections above the glue pot, the hot melt glue is applied into the individual sheets of the sections.

##### Nipping Station

Immediately after application of the glue on the spine side, the clamp takes the sections of the book to the nipping station. In the nipping station, the cover is fed. When the sections of the book come above the cover, the nipping mechanism presses the cover against the book. The cover gets attached firmly on to the book.

##### Delivery Station

After the cover is attached the completed book is delivered onto the delivery tray.

## 4.5 – Case Binding – Preparation of case and casing-in.

### *Case Bound (Hard Cover)*

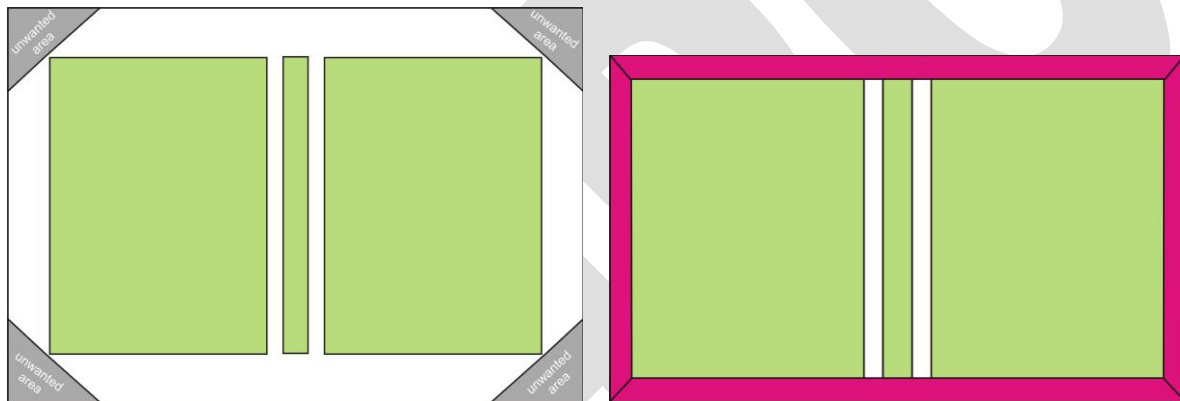
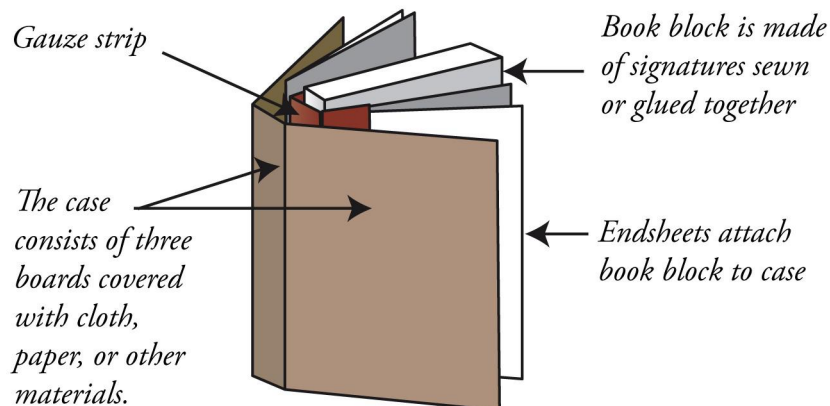

- Large printed sheets should be first folded to form signatures.
- Two end papers must also be folded for each book.
- End papers should be glued to the front of the first signature and to the back of the last signature.
- This process is called tipping and should be done after the signatures have been gathered and sewn.
- Then the cover board and the stiffeners should be measured and cut according to our requirements.
- After this the covering material should be cut according to the size of the book.
- Then the boards and stiffener should be placed on the covering material and marked.
- The unwanted corners of the covering material should be cut.
- Then the covering material should be applied with glue

- The cover boards and stiffeners should be pasted over it.
- All the sides of the covering material should be turned in.
- Then the prepared section should be allowed to dry under pressure.
- After that the case should be attached to the endpapers of the sewn book.
- This process is called as **casings-in**.
- Then the book should be kept under pressure in the nipping press.

AGPC

**Unit - V****Automation in Binding****5.1 – Programmable Cutting Machine and its operations – machine bed, clamp, back gauge, knife and safety mechanisms.**

The machine used for cutting and trimming the sheets or boards is called as single knife guillotine or paper cutting machine.

A programmable cutting machine is a power operated machine with automated features which facilitate and speed up the work. One of the salient features is the ease and perfection in label cutting.

The important parts of the programmable cutting machine are bed, clamp, knife, back gauge and safety devices.

**Machine bed**

The bed is the base platform of the machine made of steel. One third ( $1/3$ ) length of the bed is in front of the knife and two thirds ( $2/3$ ) is behind the knife. The width of the bed is actually, the size of the machine. On the surface of the bed air blast marbles are provided at equal intervals to facilitate the easy movement of the paper pile. In some latest machines, to increase the output and speed up the work, hydraulic lifting rams are provided on both the sides of the table.

**Back gauge**

Back gauge is the important part of the machine. The squareness and perfection of the cutting depends upon the proper positioning of the back gauge during assembly. It must stand exactly in right angle to the bed and move to and fro exactly parallel to the knife.

In programmable cutting machine, the back gauge movement is performed by a motor which is controlled by the programme. With the help of the computer electronic system, the movement of the back gauge, lowering down of the clamp and the knife are activated fully automatically.

### **Clamp**

It is a square block of heavy steel used to give pressure over the stock being cut. It is essential to have firm pressure on the stock while cutting. Otherwise the work will be affected with rough edges, unevenness in size etc. The clamp is pressed down or moved up with the help of hydraulic mechanism. The hydraulic mechanism gives the required amount of pressure for accurate cutting. The clamp can also be lowered down by a foot operated pedal to adjust the pile of the paper according to the cutting marks printed on the paper. While cutting operation is performed, the clamp is activated automatically and it presses the pile before knife strikes the paper.

### **Knife**

Knife blade is made of medium carbon steel, chrome and other alloys. The knife is fixed to a knife beam with screws. The knife beam is moved by an eccentric action with the help of a motor which is controlled by the computer electronics. For this we have to press two buttons. Electronically controlled machine activates the knife automatically as per preset programme.

### **Safety devices**

The accidents occurred in printing industry are mostly because of this most dangerous risky machine. That is why the cutting machine is automated with safety devices. The safety devices used are

- **Automatic sweep away bodyguards (or) Automatic push body guards**

These are automatically activated when the knife movement starts and thrust away the operator from the cutting area.

- **Interlocked guards**

These are brackets which cover the whole cutting area and are to be closed before starting knife action.

- **Photoelectric devices**

These are fixed on both sides of the cutting area. Any action by the body of the operator that breaks the beam of the light will halt the knife at once.

- **Double push button system**

It engages both the hands of the operator to activate knife. Hence there are less chances of accidents.

## 5.2 – Folding Machine and its operations – buckle folding, knife folding and combination folding stations.

Folding can be generally classified as manual and mechanical folding. Manual folding is done manually with help of bone folder. Mechanical folding is done with the help of folding machine.

### Principles of folding machine (or) Mechanical folding

In the process of mechanical folding (or) a folding machine, two techniques are used namely,

- Buckle folding
- Knife folding

#### Buckle folding

A buckle folding station consists of three rollers and a buckle plate. The first two rollers are arranged vertically above one another. These are called as forwarding rollers. The forwarding rollers carry the incoming sheet into the buckle plate until it reaches an adjustable feed guide stop.

As the lead edge of the sheet strikes the feed guide stop, the sheet continues to be fed into the buckle plate creating a buckle in the space between the three rollers. The buckle created is grabbed by the contra rotating rollers and the fold is formed as the sheet passes through them.

Each folding station can fit up to six buckle plates arranged alternatively above and below.

#### Knife folding

Knife folding uses a vertically moving knife and two rollers rotating in opposite directions. The sheet goes and stops at the sheet stop. At this point, the knife descends vertically and plunges (or) inserts the sheet

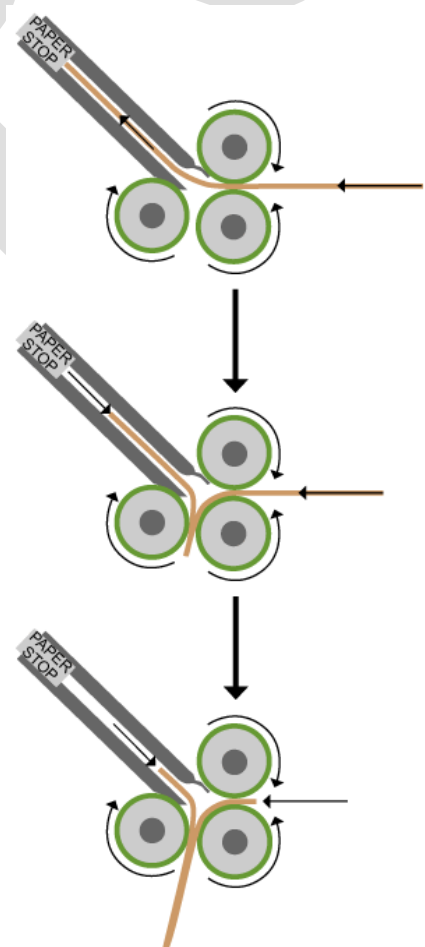



through the rollers. As the sheet passes through the rollers, the sheet is creased and the fold is formed.

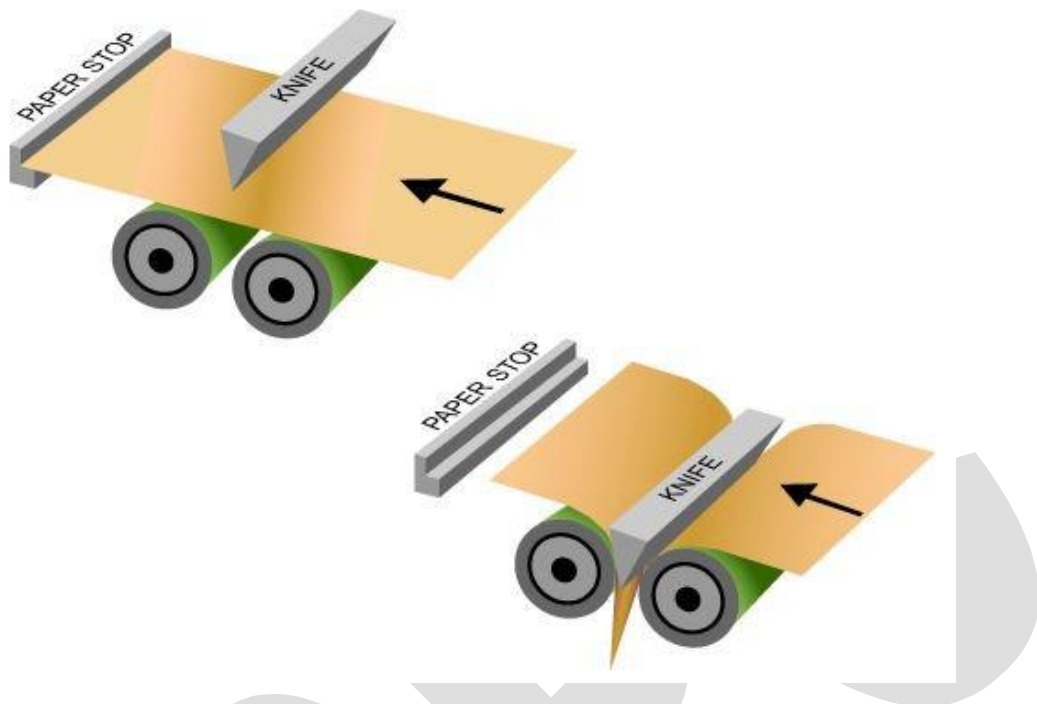

Only one folding knife is to be found in any folding station. For every subsequent fold, it is necessary to have a further knife folding station at right angle to the preceding one.

### **5.3 – Wire Stitching Machine and its operations – wire unwind, wire straightener, cutter block, saddle and wire clenchers.**

It is the simplest but very important machine in binding department. Most of the works are done using wire stitching machine because it is the quickest and cheapest method of binding. The wire stitching machine consists of the following parts.

1. Wire Spool
2. Wire Straightener
3. Cutter Block
4. Wire Head Rollers
5. Driver
6. Clencher
7. Bed

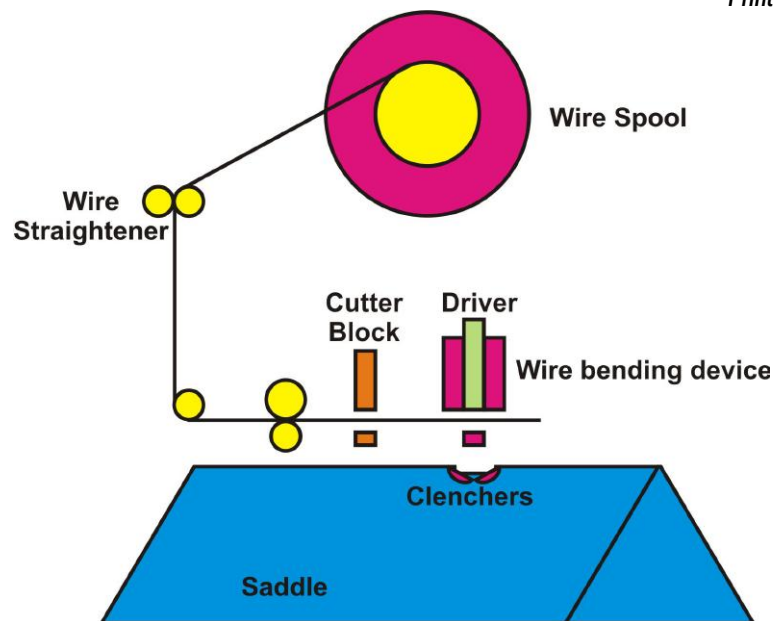

### Wire Spool

It is present at the top of the machine. The reel of wire is wound around a steel roller. During the machine running, the reel is unwound from this roller. The wire is made of copper coated around steel wire.

### Wire Straightener

The wire straightener consists of two steel rollers. The wire is made straight when the wire passes between these two rollers.

### Cutter Block

The cutter block cuts the wire according to the thickness of the book. For this we have already set the cutting length according to the thickness of the book. False setting may lead to improper stitching.

### Benders

The legs of the staple are then formed by bending the wire down on either side of the block. Then the driver drives the "U" shaped staple into the book kept on the bed.

### Bed

The book to be stapled is placed on the bed or saddle. The bed can be adjusted according to the style of stitching. The saddle can be adjusted for both side and saddle stitching` .

### Clenchers

The clenchers underneath the bed bends the legs of the staples to close the stitch.

**5.4 – Rounding and Backing Machine and its operations – hopper, rounding station, backing station and delivery station.**

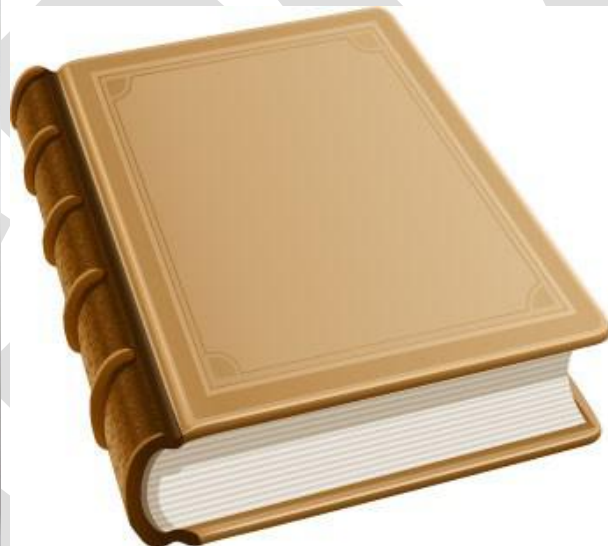
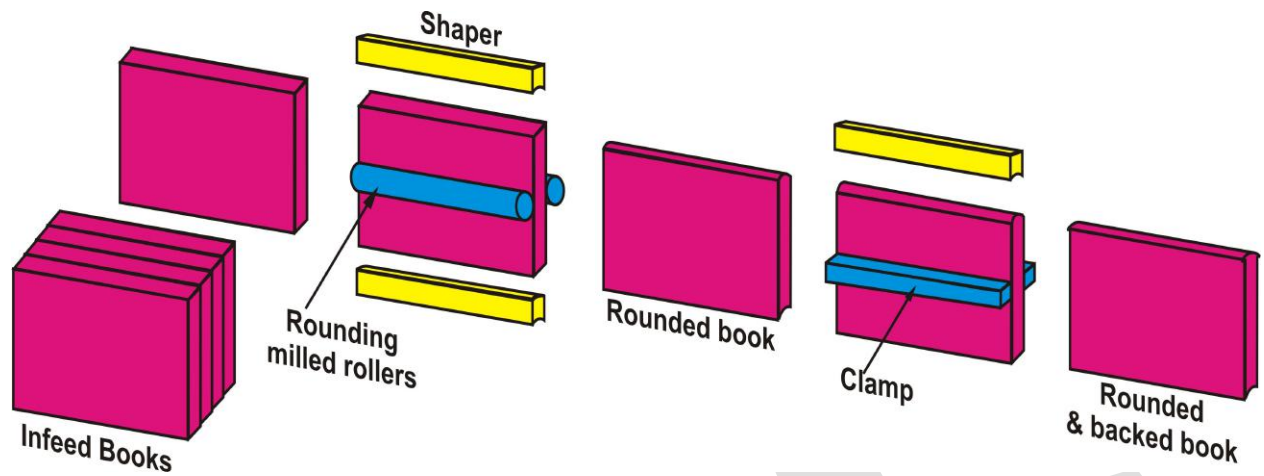

The spine glued books are stacked in the hopper. The fore edge of the book is kept down. Then the book is transferred in between two milled rounding rollers. There are shapers. One is at the

spine side and the other one is at the fore edge of the book. The rounding rollers move the book up and down. Due to this the shapers make the book rounded by pressing the end sections towards the fore edge. Then the rounded book is moved to the backing station. Here there is a wiper. It moves across the spine side of the book and hammers hard blows. Due to this the book gets backed at the spine. Finally the book is delivered.

### 5.5 – Gathering Machine and its operations.

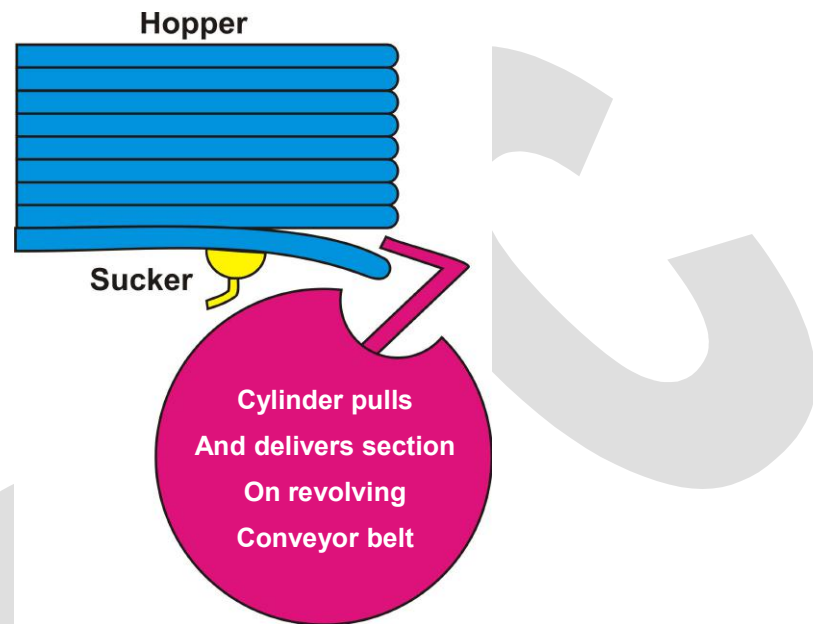

In gathering machine, the piles of different sections of a book are placed in separate hoppers. The sections are placed in consecutive order. The bottom section from each hopper is pulled by suckers. The suckers give the section to a gripper arm. The gripper takes the section and drops it on a revolving conveyor belt. When the dropped section reaches the next station or hopper, the next section is dropped over this section. Finally the book is collected. This is transported to another conveyor belt, which delivers the gathered sections to the delivery stacker.

# **PRINT FINISHING AND CONVERTING**

## PREFACE

This book of Print Finishing and Converting covers all the topics in a clear and organized format for the Second year Diploma in Printing Technology students as prescribed by the Directorate of Technical Education, Chennai, Tamilnadu. It is confidently believed that this book furnishes the students the necessary study material. The topics covered were neatly illustrated for better understanding of the students.

The book is prepared step-by-step lessons in large, eye pleasing calligraphy make it suitable for both direct one-to-one tutoring and regular classroom use. The highlight of this book is its simple English with clear and easy explanation of each topic.

All the topics are explained with supporting diagram for diploma level students to understand effectively.

This book majorly deals with Introduction to Binding, Finishing and Enhancement, Materials used in Binding, Forwarding Operations, Binding Operations and Automation in Binding etc.

G.Venkateswaran, Lecturer (SS) / Print. Tech.

N.Sivaraman, Lecturer (SS) / Print.Tech

Arasan Ganesan Polytechnic College

Sivakasi.

## PRINT FINISHING AND CONVERTING

### DETAILED SYLLABUS

Contents: Theory

| Unit       | Name of the Topic   | Hours          |
|------------|---|----------------|
| <b>I</b>   | <b>Binding, Finishing and Enhancement– Introduction</b><br>1.1 - Brief Introduction to Print Finishing. Classification of Book Binding – Quarter bound book, Half bound book – old style and new style and Full bound book.<br>1.2 - End Paper – Types and its uses - Single End Paper, Made End Paper, Reinforced End Paper, Cloth Joint End Paper and Zig Zag End Paper.<br>1.3 - Binding and Finishing Tools - Folder, Glue Brush, Paste Brush, Spring Divider, Needle, Tennon Saw, Hammer, Foot Rule, Knife, Bodkin, Piercer/Awl, Eyelet punch, Scissors, Carpenter’s L – Square, Center Tool, Round Roll, Fillet and Type Holder.<br>1.4 - Lamination Machine - Different types of lamination machines - Dry Lamination, Wet lamination, Thermal Lamination, Strip lamination and Window Lamination.<br>1.5 - Varnishing, Full varnishing and Spot Varnishing. Types of varnish - matt and gloss varnishing - water (Aqua) based, solvent based - UV and special effect varnish. | <b>10 Hrs</b>  |
| <b>II</b>  | <b>Materials used in Binding</b><br>2.1 - Ware House, Types of Ware House – White paper Ware House and Printed paper Ware House.<br>2.2 - Covering Materials – Binding cloth, Buckram cloth, Rexene, Leather, Paper fabric and PVC.<br>2.2 - Reinforcing Materials – Mull Cloth, Calico Cloth, Tapes and Cords.<br>2.3 - Securing Materials – Thread, Wire, Metal and Plastic Units.<br>2.4 - Adhesives – Paste, Glue, Synthetic Adhesive, Hot-melt and Gum.<br>2.5 - Book Finishing Materials – Gold leaf and Blocking foil.   | <b>10 Hrs</b>  |
| <b>III</b> | <b>Forwarding Operations</b><br>3.1 - Cutting, Trimming, Difference between Cutting and Trimming, Folding – Types of Folding – Folding-to-paper, Folding-to-Print and Lump Folding.<br>3.2 - Creasing, Gathering, Collating, Binder’s/Collating mark, Inserting and Attaching of Plates and Maps.<br>3.3 - Perforating – Types of Perforation, Punching and Drilling, Numbering – Horizontal Numbering and Vertical Numbering.<br>3.4 - Die cutting and Slitting Operations.  | <b>10 Hrs.</b> |

| Unit      | Name of the Topic   | Hours         |
|-----------|---|---------------|
|           | 3.5 - Headbands, Edge Decoration, Types of Edge Decoration – Colouring the edge, Marbling and Edge Guilding.  |               |
| <b>IV</b> | <b>Binding Operations</b><br>4.1 - Stitching – Side Stitching and Saddle Stitching.<br>4.2 - Sewing, Types of Sewing – French Sewing, Tape Sewing or Sewing on Tapes, Raised Cord Sewing or Flexible Sewing, Recessed Card Sewing or Sawn-in Sewing, Two on & All along Sewing and Overcast Sewing.<br>4.3 - Loose Leaf Binding – Spiral Binding and Comb Binding.<br>4.4 - Perfect Binding – clamping station, milling station, gluing station, nipping station and delivery station.<br>4.5 - Case Binding – preparation of case and casing-in.                         | <b>10 Hrs</b> |
| <b>V</b>  | <b>Automation in Binding</b><br>5.1 - Programmable Cutting Machine and its operations – machine bed, clamp, back gauge, knife and safety mechanisms.<br>5.2 - Folding Machine and its operations – buckle folding, knife folding and combination folding stations.<br>5.3 - Wire Stitching Machine and its operations – wire unwind, wire straightener, cutter block, saddle and wire clencher.<br>5.4 - Rounding and Backing Machine and its operations – hopper, rounding station, backing station and delivery station.<br>5.5 - Gathering Machine and its operations. | <b>10 Hrs</b> |