

PRINT SHOP



PRINTING GUIDE 2020-2021



PUBLICATION SERVICES

It is our goal to provide you with the highest quality service at or below outside printing vendor prices. If you don't see a product/service listed that you currently outsource, let us know. We are always looking to see how we can expand our services to better serve our IUSD community!

GENERAL CONTACT INFO

Email
printshop@iusd.org
Phone
(949) 936-8685

Website
iusd.org/publicationservices
Submit Print Order
iusd.webdeskprint.com

TEAM MEMBERS

John van Doleweerd
Foreman
(949) 936-5326
JohnVandoleweerd@iusd.org

Ken Kafton
Lead Press Operator
(949) 936-8463
KenKafton@iusd.org

Brenda Recinos
Publications Technician
(949) 936-5307
BrendaRecinos@iusd.org

Ignacio "Nacho" Montes
Bindery Assistant
(Part-Time)
IgnacioMontes@iusd.org

HOURS PICKUP DELIVERY

MON - FRI
7AM - 3:30PM
*closed on school
holidays and weekends*

IUSD M&O
100 Nightmist
Irvine, CA 92618

District departments and school orders are delivered by the IUSD Warehouse M-F, between 7am-12pm.

TABLE OF CONTENTS

Services Offered.....	1
Timelines.....	2
Copyright Warning.....	3
Light Weight Papers.....	4-6
Medium Weight Papers.....	7-10
Cardstock Papers.....	11-15
Certificate Borders.....	16-17
Envelopes.....	18-19
NCR Paper.....	20-21
Store Orders.....	22-28
Reams of Paper.....	23
Bordered Certificates.....	24
District Curriculum.....	25
Blank Envelopes/Forms.....	26
District Calendars.....	27
Writing Papers.....	28
Bindery Glossery.....	29-30

SERVICES OFFERED

Black and White Copies

One- or two-sided copies, 8-1/2"x11" up to 11"x17".
Paper stocks: light weight papers up to 100 lb. cover stock.

Full Color Printing

Sizes: 8-1/2"x11" up to 11"x17". We have two options: 1) INKJET copier (Comcolor), prints a "good quality" color copy for a lower cost, or 2) LASER copier (Canon ImagePress), produces a "best quality" document for a few cents more. Unless specified otherwise, print orders will automatically default to ImagePress.

Posters

Sizes: 20"x28", 23"x35", 28"x40"
Poster Material: White Cardstock

Banners

Sizes: Lengths: from 3 ft. to 8 ft. with choice of two widths: 36 in. or 42 in.
Banner Material: 15 mil Vinyl, 8 mil Poly Gloss, 24 lb. and 45 lb. matte banner paper.

Retractable Banners

Width: 36in. with a length up to 82in.
Material: 8 mil matte paper, stand, carrying/storage bag.

The following are examples of projects we print throughout the district:

Stapled Packets • Straight Copies • Vinyl Banners
Paper Banners • Posters • Envelopes • Curriculum Books
Letterhead • Business Cards • Writing Paper • Calendars
Bell Schedules • Hallway Passes • Stationery • Postcards
Notepads • NCR Forms • Student Reward Tickets • Paper Name Plates
ODR forms or pads • Placement Cards • Certificates
Student Planners • Conduits • Counselor Slips • Newsletters
Programs • Memory Books • Custom Tab Dividers

TIMELINES

Normal turnaround time is

3-5 business days

from the date the order is received in the Print Shop.

Large distributions, spiral binding, programs and directories require additional time.

April - June

These months are considered peak times for the shop. Production time can increase to 7-10+ business days.

During this time we are printing Graduation/Promotion programs, certificates/awards, end of year newsletters, year round school orders, end of year performance programs and advertisements and summer school orders.

Summer

Summer is also a peak time for the shop. Most sites will submit the bulk of their orders for the beginning of the following year right before school is out. For these orders, please indicate your “must have” date by changing the default due date or including it in the special instructions.

During this time we are printing year round school orders, student planners, PTA material, fall science lab manuals and traditional school orders needed by the start of the next school year.

“Bill Next Year”

For orders that are submitted before summer break but need to be billed for the following school year, include “BNY” or “Bill Next Year” in the job title of your order. This helps us flag your order so that we don’t mark it shipped until after July 1st. An email will be sent out to schools in April with the date that we can begin accepting these types of orders.

COPYRIGHT WARNING

Fair use is a legal doctrine that promotes freedom of expression by permitting the unlicensed use of copyright-protected works in certain circumstances. Section 107 of the Copyright Act provides the statutory framework for determining whether something is a fair use and identifies certain types of uses—such as criticism, comment, news reporting, teaching, scholarship, and research—as examples of activities that may qualify as fair use. Section 107 calls for consideration of the following four factors in evaluating a question of fair use:

- **Purpose and character of the use, including whether the use is of a commercial nature or is for nonprofit educational purposes:** Courts look at how the party claiming fair use is using the copyrighted work, and are more likely to find that nonprofit educational and noncommercial uses are fair. This does not mean, however, that all nonprofit education and noncommercial uses are fair and all commercial uses are not fair; instead, courts will balance the purpose and character of the use against the other factors below. Additionally, “transformative” uses are more likely to be considered fair. Transformative uses are those that add something new, with a further purpose or different character, and do not substitute for the original use of the work.
- **Nature of the copyrighted work:** This factor analyzes the degree to which the work that was used relates to copyright’s purpose of encouraging creative expression. Thus, using a more creative or imaginative work (such as a novel, movie, or song) is less likely to support a claim of a fair use than using a factual work (such as a technical article or news item). In addition, use of an unpublished work is less likely to be considered fair.
- **Amount and substantiality of the portion used in relation to the copyrighted work as a whole:** Under this factor, courts look at both the quantity and quality of the copyrighted material that was used. If the use includes a large portion of the copyrighted work, fair use is less likely to be found; if the use employs only a small amount of copyrighted material, fair use is more likely. That said, some courts have found use of an entire work to be fair under certain circumstances. And in other contexts, using even a small amount of a copyrighted work was determined not to be fair because the selection was an important part—or the “heart”—of the work.
- **Effect of the use upon the potential market for or value of the copyrighted work:** Here, courts review whether, and to what extent, the unlicensed use harms the existing or future market for the copyright owner’s original work. In assessing this factor, courts consider whether the use is hurting the current market for the original work (for example, by displacing sales of the original) and/or whether the use could cause substantial harm if it were to become widespread.

In addition to the above, other factors may also be considered by a court in weighing a fair use question, depending upon the circumstances. Courts evaluate fair use claims on a case-by-case basis, and the outcome of any given case depends on a fact-specific inquiry. This means that there is no formula to ensure that a predetermined percentage or amount of a work—or specific number of words, lines, pages, copies—may be used without permission.

Please note that the Copyright Office is unable to provide specific legal advice to individual members of the public about questions of fair use. See [37 C.F.R. 201.2\(a\)\(3\)](#).

<https://www.copyright.gov/fair-use/more-info.html>



20 LB. BOND

Blue

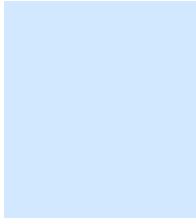

Paper Size

8.5" x 11"
8.5" x 14"
11" x 17"

20 lb. (Lightweight)

A general use,
lightweight paper
used for manuals,
reports, letters,
forms and flyers.

Paper colors may
vary slightly with
mill run.

White



Paper Size

8.5" x 11"
8.5" x 14"
11" x 17"

Canary

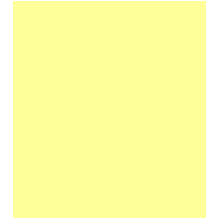

Paper Size

8.5" x 11"
8.5" x 14"
11" x 17"

Green

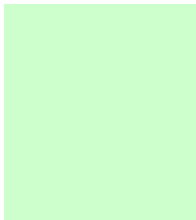

Paper Size

8.5" x 11"
8.5" x 14"
11" x 17"

Orchid

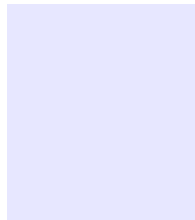

Paper Size

8.5" x 11"

Buff



Paper Size

8.5" x 11"
8.5" x 14"
11" x 17"

Pink

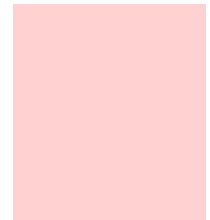

Paper Size

8.5" x 11"
8.5" x 14"
11" x 17"

Goldenrod



Paper Size

8.5" x 11"
8.5" x 14"
11" x 17"

Tan



Paper Size

8.5" x 11"
11" x 17"

Gray

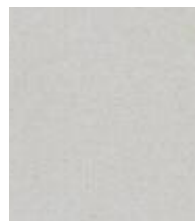

Paper Size

8.5" x 11"

Ivory

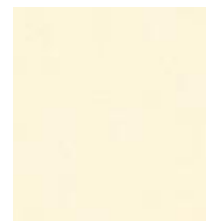

Paper Size

8.5" x 11"
11" x 17"

24 LB.

24 lb. (Lightweight)

The 24 lb. bond paper is a general use, lightweight paper. It has slightly less show through than the 20 lb bond white paper when printed double sided.

Capitol Bond is a nice quality paper for letterhead with a watermark embedded in the paper.

White Bond

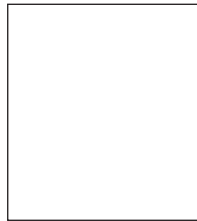

Paper Size
8.5" x 11"

Capitol Bond



Paper Size
8.5" x 11"



60 LB. ASTROBRIGHT TEXT

Stardust White



Paper Size
8.5" x 11"

60 lb. (Lightweight)

A general use, lightweight paper used for manuals, reports, letters, forms and flyers.

Paper colors may vary slightly with mill run.

Re-entry Red



Paper Size
8.5" x 11"

Lunar Blue

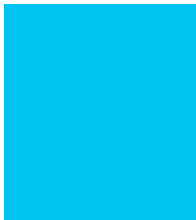

Paper Size
8.5" x 11"

Pulsar Pink



Paper Size
8.5" x 11"

Hot Pink

Terra Green



Paper Size
8.5" x 11"

Solar Yellow

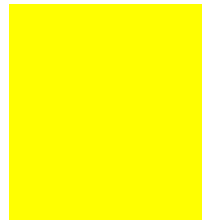

Paper Size
8.5" x 11"

Orbit Orange



Paper Size
8.5" x 11"

Gamma Green



Paper Size
8.5" x 11"

Planetary Purple



Paper Size
8.5" x 11"

60 LB. ASTROPARCHE TEXT

60 lb. (Lightweight)

These stocks have an antique mottled pattern and are recommended for certificates, letterheads and invitations.

This parchment-type paper should only be printed on one side due to bleed through, however, it will print fine with a two-sided copy if you only use black ink and the ink coverage is light (text only or minimal graphics).

White



Paper Size
8.5" x 11"

Natural



Paper Size
8.5" x 11"

Sand

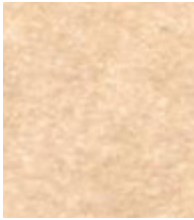

Paper Size
8.5" x 11"

Light Blue

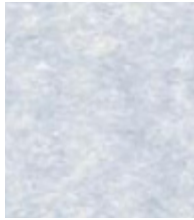

Paper Size
8.5" x 11"

70 LB. LINEN TEXT

70 lb. (Medium weight)

Linen is a semi-rough paper that emulates the look of linen cloth with slightly lifted grooves to give a textured feel. This paper is recommended for certificates, newsletters, letterheads and invitations.

Some colors, sizes and bulk quantities may need to special ordered. Please email us to check on availability for any large project.

White



Paper Size

8.5" x 11"

8.5" x 14" and 11" x 17"
available by Special Order

Ivory



Paper Size

8.5" x 11"

8.5" x 14" and 11" x 17"
available by Special Order

Gray



Paper Size

8.5" x 11"*

*ONLY available by Special
Order



65 LB. ASTROBRIGHT COVER

Galaxy Gold



Paper Size
8.5" x 11"

**65 lb.
(Heavyweight/cardstock)**

Miscellaneous bright colors. These stocks can be used for programs, covers and other general purpose printing.

Re-entry Red



Paper Size
8.5" x 11"

Lunar Blue

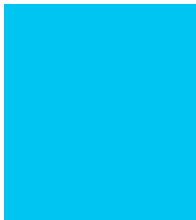

Paper Size
8.5" x 11"

Pulsar Pink



Paper Size
8.5" x 11"

Hot Pink

Terra Green



Paper Size
8.5" x 11"

Solar Yellow

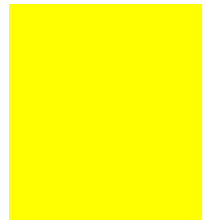

Paper Size
8.5" x 11"

Orbit Orange



Paper Size
8.5" x 11"

Gamma Green

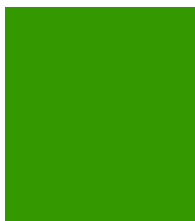

Paper Size
8.5" x 11"

Planetary Purple



Paper Size
8.5" x 11"

65 LB. ASTROPARCHE COVER

**65 lb.
(Heavyweight/Cardstock)**

These stocks have an antique mottled pattern and can be used for invitations, notecards and program covers.

This heavier stock is a "Special Order" paper and may require additional production time depending on availability.

White



Paper Size
8.5" x 11"

Natural



Paper Size
8.5" x 11"

Sand



Paper Size
8.5" x 11"

Light Blue



Paper Size
8.5" x 11"

80 LB. LINEN COVER

80 lb. (Heavyweight/Cardstock)

Linen is a semi-rough paper that emulates the look of linen cloth with slightly lifted grooves to give a textured feel. This paper is recommended for awards, invitations, business cards, stationery and the cover for programs.

Some colors, sizes and bulk quantities may need to special ordered. Please email us to check on availability for any large project.

White



Paper Size

8.5" x 11"

8.5" x 14" and 11" x 17"
available by Special Order

Ivory



Paper Size

8.5" x 11"

8.5" x 14" and 11" x 17"
available by Special Order

Gray



Paper Size

8.5" x 11"*

*ONLY available by Special
Order

Blue



Paper Size

8.5" x 11"*

*ONLY available by Special
Order

110 LB. INDEX

White

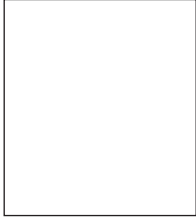

Paper Size

8.5" x 11"
8.5" x 14"
11" x 17"

110 lb. (Heavyweight/cardstock)

A durable, general purpose card stock used for postcards, brochures, dividers, tickets, programs and file cards.

Paper colors may vary with mill run.

Index paper is the most inexpensive of all the brands of cardstock papers that we carry.

Canary

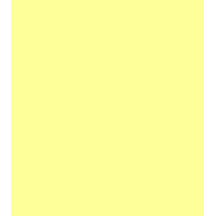

Paper Size

8.5" x 11"
8.5" x 14"
11" x 17"

Green

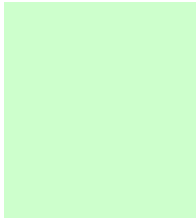

Paper Size

8.5" x 11"
8.5" x 14"
11" x 17"

Blue

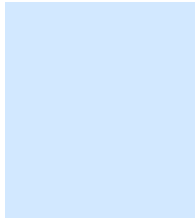

Paper Size

8.5" x 11"
8.5" x 14"
11" x 17"

Buff



Paper Size

8.5" x 11"
8.5" x 14"
11" x 17"

Cherry

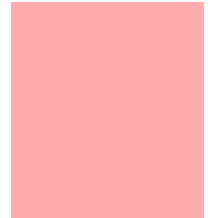

Paper Size

8.5" x 11"
8.5" x 14"
11" x 17"

Salmon



Paper Size

8.5" x 11"
8.5" x 14"
11" x 17"

Gray



Paper Size

8.5" x 11"
8.5" x 14"
11" x 17"

Ivory



Paper Size

8.5" x 11"
8.5" x 14"
11" x 17"



CERTIFICATE BORDERED PAPER

**70 lb.
(Medium Weight)**

These colored borders are printed on 8.5" x 11" 70lb White Linen Text and available to add to any text document for printing.

Personalization (such as student names, dates etc) is also available. Please email the shop to inquire about the process for this service.

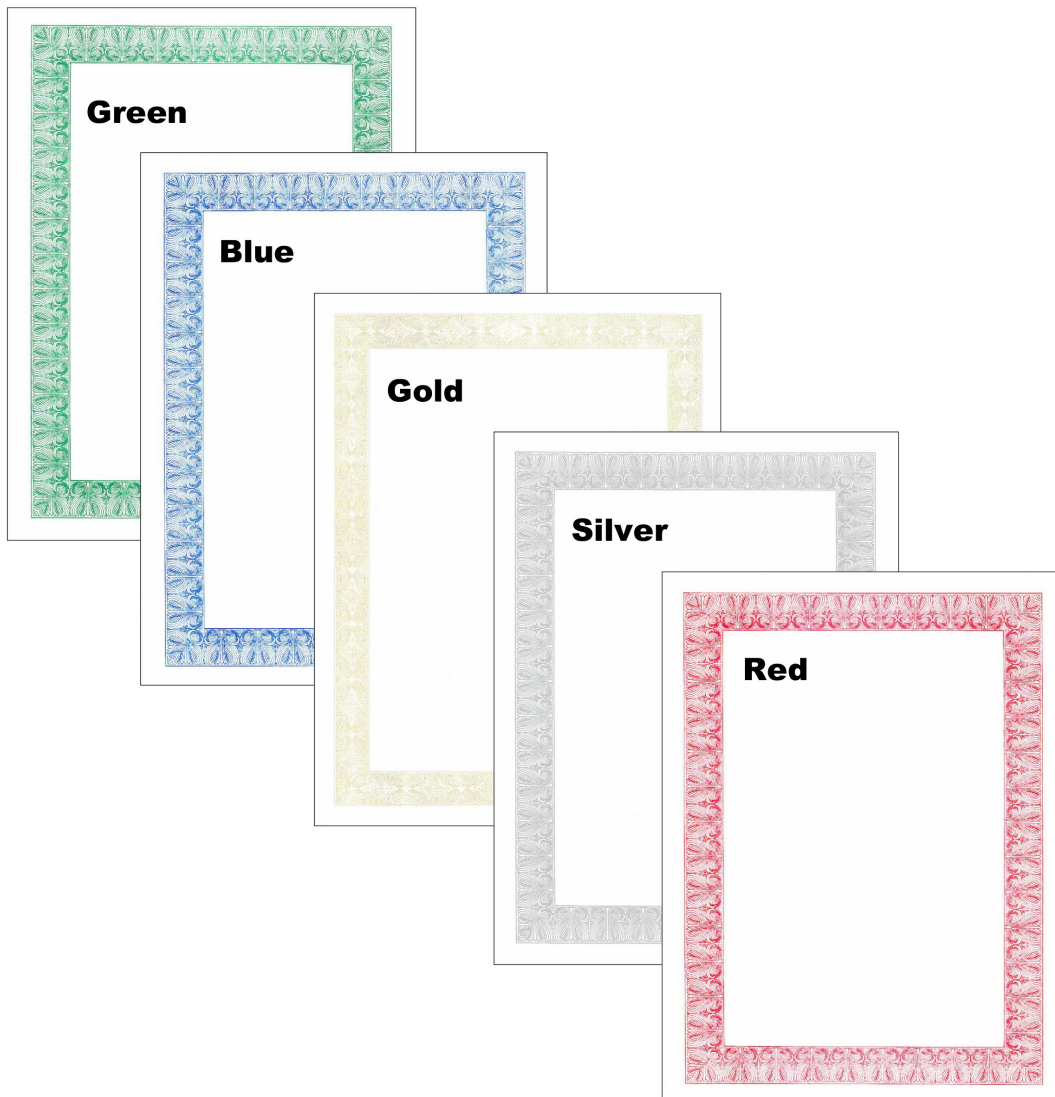



**Envelopes
WHITE**

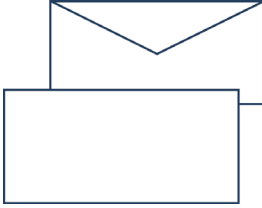

Sizes:
#9
#10

500 per box

**Envelopes
WHITE w/Window**

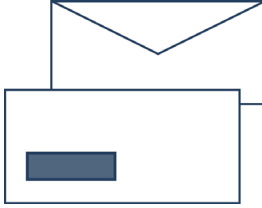

Sizes:
#10

Available in Left or
Right window.

500 per box

**Envelopes
*Special Order***

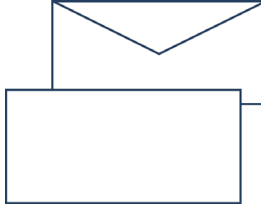

Sizes:
#10 Linen
#10 Parchment

500 per box

**Envelopes
WHITE**

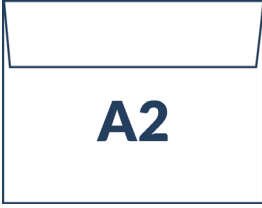

A2

Sizes:
#A2 Linen
(5-3/4" x 4-3/8")
*Corresponds with A2
Notecard size.*

250 per box

**Envelopes
WHITE**

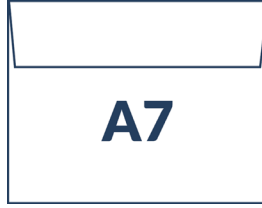

A7

Sizes:
#A7 Linen
(7-1/4" x 5-1/4")
*Corresponds with A7
Invitation size.*

250 per box

**Catalog
WHITE**



Sizes:
6" x 9"
6-1/2" x 9-1/2"
9" x 12"
9-1/2" x 12-1/2"
10" x 13"

500 per box

**Catalog
MANILA**

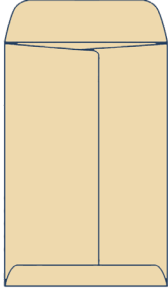

Sizes:
6" x 9"
6-1/2" x 9-1/2"
9" x 12"
9-1/2" x 12-1/2"
10" x 13"

500 per box

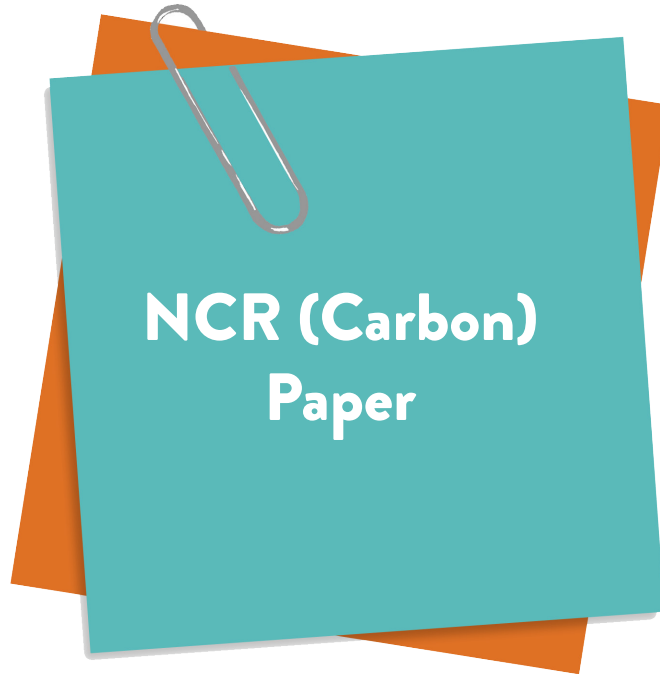

NCR CARBONLESS PAPER

**20 lb.
(Light Weight)**

These stocks are available in 8.5" x 11" size sheets and come in the order that they are shown below.

2 Part NCR

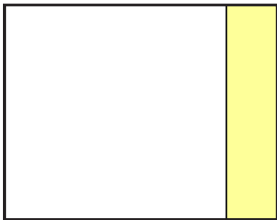

White / Canary

8.5" x 11"

250 sets per ream

3 Part NCR



White / Canary/ Pink

8.5" x 11"

137 sets per ream

4 Part NCR

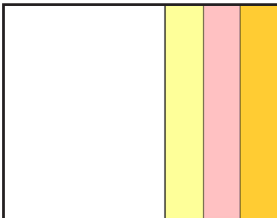

White / Canary / Pink /

Goldenrod

8.5" x 11"

125 sets per ream

5 Part NCR

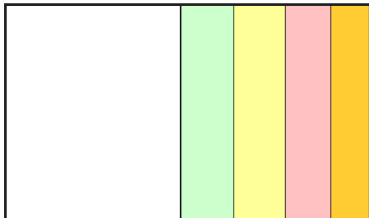

White / Green / Canary /

Pink / Goldenrod

8.5" x 11"

100 sets per ream



This section of our website is for items that are “ready to order”. All of the printing details have been preselected and files are attached. The items are not stocked (with the exception of blank paper), they are printed on demand. The ordering process is similar to online shopping, just select the item, add to cart and update the quantity needed before checking out. Some items may have special instructions for ordering, please read the description to make sure you are ordering correctly.

REAMS OF PAPER

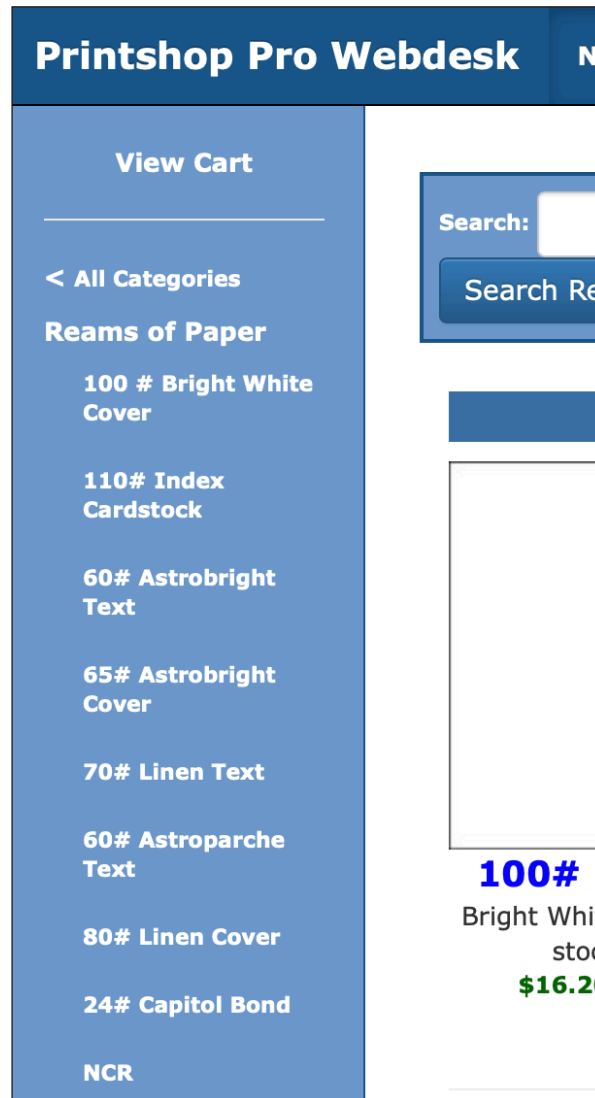

Here you will find blank paper stock sold by the ream.

NCR paper reams come blank and unglued.
Currently, only the 5 part NCR is available through Store Orders.

Due to limited space in our warehouse, we have to limit orders to a maximum of 3 reams per stock.

BORDERED CERTIFICATES

View Cart

< All Categories
Bordered Certificates

Products In Bordered Certificates

Certif Borders
Blue Certificate Borders-8.5x11, Sheet
\$0.06 per Sheet

Certif Borders
Red Certificate Borders-8.5x11, Sheet
\$0.06 per Sheet

Certif Borders
Gold Certificate Borders-8.5x11, Sheet
\$0.06 per Sheet

Certif Borders
Silver Certificate Borders-8.5x11, Sheet
\$0.06 per Sheet

Certif Borders
Green Certificate Borders-8.5x11, Sheet
\$0.06 per Sheet

The certificates offered under this category are the same available for us to print on under printing orders.

When purchasing under store orders, you will receive the certificate paper printed with the border only.

The minimum order quantity is 25 sheets.

DISTRICT CURRICULUM

[View Cart](#)

[< All Categories](#)

District Curriculum

- [HMH Journeys Student Edition \(Kinder\)](#)
- [HMH Journeys Blend It Books](#)
- [HM Medallion Phonics Library \(Original Font\)](#)
- [HM Medallion Phonics Library \(Enlarged Font\)](#)
- [HM Medallion Decodable Readers](#)
- [HM Medallion Dictation \(Enlarged Font\)](#)
- [HM Readers Library Blackline Masters](#)
- [HM I Love Reading](#)
- [HM Theme Skills Test](#)
- [HM High Frequency Word Grids](#)
- [Real Word Chains](#)
- [VH Factwise Flashcards](#)
- [Study Sync](#)
- [VH Tuning Up Computationally](#)

EXAMPLE:

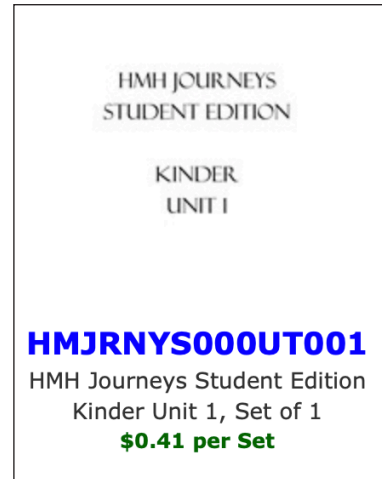

HMJRNY000UT001

HMH Journeys Student Edition Kinder Unit 1, Set of 1

Price	\$0.41 per Set (of 1)
Delivery	5 to 14 days
Details	HMH Journeys Student Edition KINDER /Unit 1 ONLY /Total # of Books: 10 /Please allow up to 2 weeks for printing OR delivered by 1st week of school
Ordering Instructions	Order ONE UNIT per Store Order Number

[Add to Cart](#)

[Continue Shopping](#) [View Cart](#)

HMH JOURNEYS
STUDENT EDITION

KINDER
UNIT 1

[View PDF](#)

This category contains all district curriculum that was provided to us (in hard copy or digital format) to allow staff to quickly order.

Please read the details and ordering instructions for each curriculum carefully. Some are sold in groups (ex. Units 1-3), others are sold per unit due to the high quantity of books per unit.

PDF files are attached to each listing, please review them to ensure you are ordering exactly what you need.

If you don't see a curriculum listed or need specific books printed within a file, do NOT order through Store Orders. Please submit any custom orders under Printing Orders so that you are charged correctly. *When submitting the order as a print order, please make sure to download the file from store orders and attach it to the printing order with the custom printing directions.*

BLANK ENVELOPES



Currently, only A2 White Linen Envelopes are available under Store Orders. These envelopes are blank and will not be printed. If you need printed envelopes, submit the entire order under Printing Orders.

ENVA2LINWHITE

A2 Linen Envelopes (White), Item

FORMS

7. www.ksd.com/00000000000000000000

Legitimate Educational Interest to Review Pupil Records

Based upon the provisions of PL 94-142, Employee Review of Pupil Records is accorded only to those who have legitimate educational interest. Parents, guardians, or students who are eighteen years or older, have a right to know when the records were reviewed, by whom, and for what reason.

Therefore, prior to reviewing this record, please indicate the following:

Student Name _____

<small>Case or Record</small>	<small>Name of Purchaser</small>	<small>Title or Position of Purchaser</small>	<small>Reason for Review</small>

FORM No. 912 8/10/06 00000000000000000000000000000000

75.80146

Legitimate Educ. Interest to Review Pupil Records,
Sheet

This form is sold by the sheet (2 forms per sheet).

DISTRICT CALENDARS

Here you will find calendars that list all district holidays as well as break periods for both traditional and year round schools. The calendars come in either calendar or fiscal year format and are updated yearly in the fall.

3 Month Calendars

Fiscal/Yearly Calendars

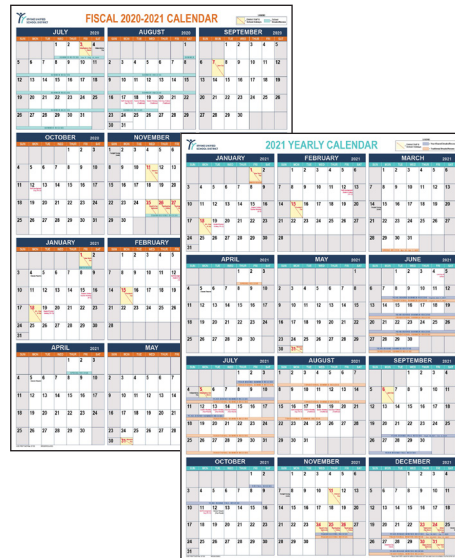

Deskpads



WRITING PAPER

We have taken the most popular writing paper orders and created ready to go orders in this category. The writing paper is printed on demand but there's no need to worry about supplying a file, just add to cart and update the quantity of reams you need.

View our complete collection online!

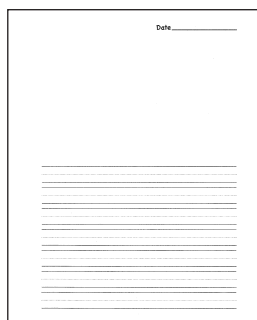
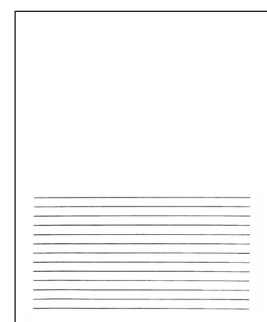
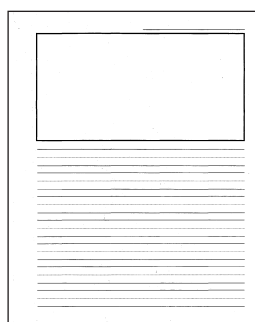
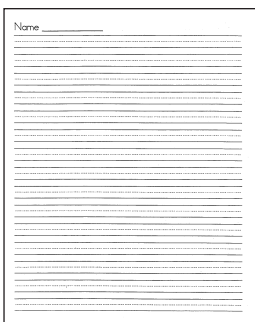
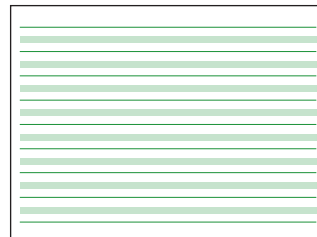
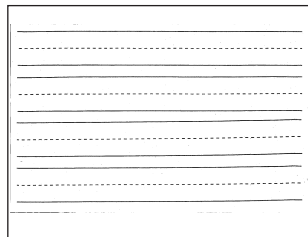
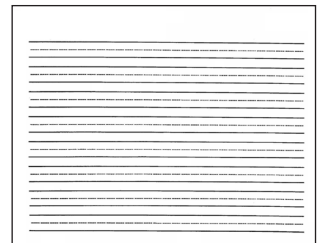
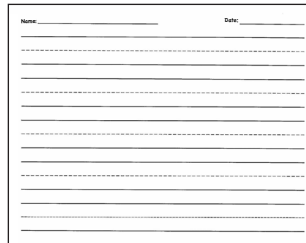
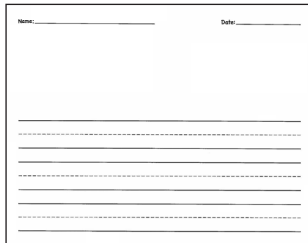

BINDERY GLOSSARY

SPIRAL BINDING / COIL BINDING

The holes for coil binding are usually either round or oval shaped. Depending on the size and spacing of the hole pattern, there will be 43 or 44 holes on an eleven-inch binding edge. Coils come in clear plastic.



COLLATE

The gathering of several sheets together in sequence; ie. pages 1, 2, 3, 4, etc. printed in sequence.



CUT/TRIM

Our Print Shop has a large guillotine/cutter for trimming jobs as small as 2”.

FOLD

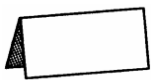

Half fold

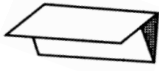

Letter fold

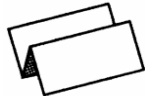

Z fold

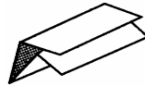

Double fold

GROUPING

Gathering of the same sheets together, i.e. Grouping can be done with collated or non-collated materials that need to be counted out or divided into stacks. *For example:* a teacher might order 140 total SETS/(copies) of a file (for 4 classrooms), and ask that it be divided into 4 groups of 35 (35 copies for each of the 4 classrooms). *Please add a note on your job ticket if you would like your order to be grouped this way.*

HOLE PUNCHING

The standard hole-punch has 3-holes for inserting copies into a notebook. Another option is a 2-hole punch. For “special orders” that require a 1- or 2-hole punch, please provide a sample of the hole placement.

NOT COLLATED

Orders not collated have the same sheets gathered together, separated into individual stacks.



BINDERY GLOSSARY CONT'D.

PAD

Pads have sheets combined together, with a glue compound applied on one edge. Padding can be used for notepads or ticket books, etc. Works best with lightweight papers. Standard pads have 50 sheets, but we can also make pads with 25 or 100 sheets, etc.

NOTE: You will also find that NCR carbon copies are glued together on one edge, but it's not necessary to choose padding for this type of order. The cost to glue NCR sheets together is automatically configured into the NCR paper charge. NCR copies will always be glued unless you ask not to.

PERFORATING / NUMBERING

We can add perforations or numbers onto your order (i.e. on tickets).

SADDLE-STITCHED BOOKLETS

Sheets folded in half with 2 staples in the center of the fold to create a booklet. (Maximum sheets of paper that can be saddle-stitched is 20, this includes the cover sheet). *Booklets folded in half with more than 20 sheets of paper (80 total pages) will require additional production time, and these booklets will need to be sent to an outside vendor for the bindery work (collating, folding in half, 2 staples in the center). *There will be an additional charge, if sent to a vendor for bindery.

STAPLE

Maximum number of sheets the copy machines can staple is 70 (except for saddle-stitching).



Staple 1 Top



Staple 1 Top
Landscape



Staple 2 Top
Landscape



Staple 2 Side



Staple 2 Center
(saddle-stitch)



Staple 3 Side
(the 3rd staple is added manually and may require additional time)