

TUFFSTUFF
FITNESS

Pro-XL Sports Performance Rack Systems



Pro-XL Sports Performance Rack Systems

Designed for the needs of the Modern Athlete!

Engineered and manufactured in the USA from superior components and featuring the latest training options. The TuffStuff Pro-XL Series has been built to satisfy the evolving needs of today's athletes! Pro-XL is more than just a series of power racks, Pro-XL is a training system engineered to accommodate any strength program or conditioning protocol that an athlete may encounter. The Pro-XL combines heavy weight frame components and TuffStuff's exclusive features like – integrated anchor loops to securely anchor suspension straps and assistance tubing used for bodyweight training, Swing Lock J hooks and Lever Lock safety rails that adjust in 3-inch increments to quickly and easily accommodate all size users, and narrow width "thick grip" frame connectors, designed to minimize contact with weight plates during overhead lifts and also function as an advanced pull-up station – all combined to accommodate multiple athletes utilizing a variety of training systems.

The TuffStuff Pro-XL Series of Sports Performance Racks & Platforms – **Equipment for the athlete in all of us!**



Dual, mid-width, "thick bar" frame connectors double as additional pull up station.



Integrated, anchor loops for suspension straps and assistance tubing used for bodyweight training, lifting aids and more.

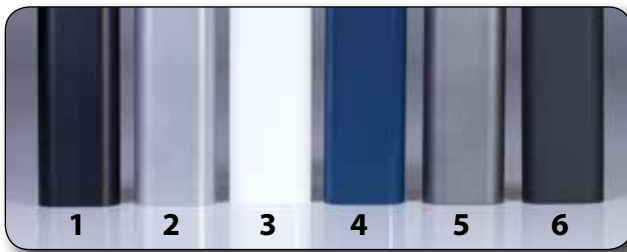

Custom two tone finish offers choice of six primary colors:
 (1) Matte Black (2) Platinum Sparkle (3) Sky White (4) Twilight Blue
 (5) Charcoal Texture (6) Wrinkle Black
 Custom color available – inquire with your sales representative.



Customize your Olympic Platform with your own logo.

Digitally printed on vinyl floor decal and die-cut to your specification. One or 4-color process logo. Please inquire with your sales representative for logo set-up fee and any additional charges.



Full length, reinforced Lever Lock™ safety rails on all full cages. (Patent Pending)



Swing Lock™, quick change steel bar catches. (Patent Pending)

With TuffStuff's Pro-XL series, you can customize your workout routine . . .



Anchor loops support bodyweight trainers.



Integrated all purpose storage hooks keep lifting accessories off the floor.



Dual Olympic bar storage keeps bars within easy reach.

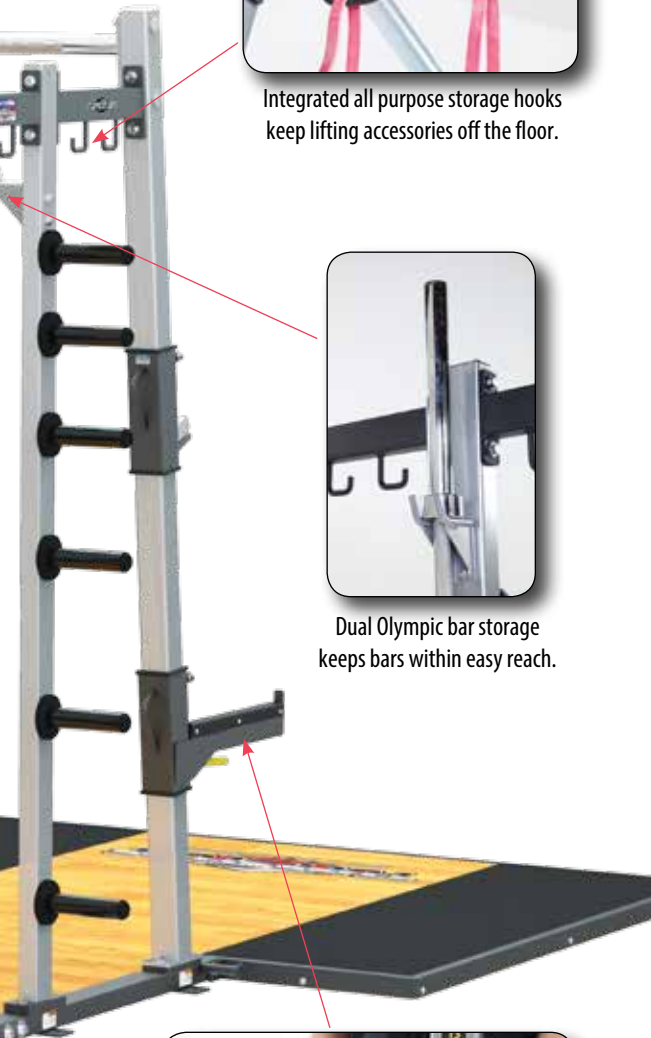

Combine traditional strength training with bodyweight exercises in circuit fashion.



Go heavy in complete safety with traditional barbell movements.



Quick change, easy move safety spotters on all Half Cages. (Patent Pending)



Attach suspension trainers and resistance bands onto the integrated anchor loops to expand your training options.



Welded power band pegs for rubber resistance band exercises.



Olympic bar, weight plates and spring clip collars not included.

PXLS-7910 Half Rack



- Space saving half rack design features adjustable Swing-Lock™ stainless steel bar catches and easy, quick change safety spotters rated to 900 lbs. weight capacity.
- 7-degree slant design ensure natural and safe racking position.
- Durable-welded knurled zinc plated multi-grip pull-up station for wide, narrow, reverse and neutral grip upper body exercises.
- Standard features include band pegs, all purpose storage hooks, anchor loops, 12-prong weight storage holders and dual Olympic bar storage.

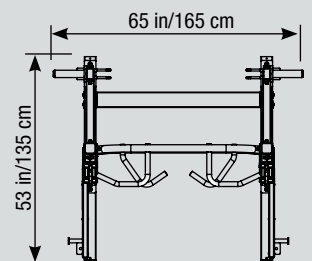

Height: 97 in/246 cm
Weight: 410 lb/186 kg

OPTION: PXL-7914 Olympic platform with inset

Weight: 400 lb/181 kg



Olympic bar, weight plates and spring clip collars not included.

PXLS-7920 Dual Rack



- Combination of two Half Racks allows multiple exercise participation for up to two users simultaneously.
- Designed to accommodate two (2) Olympic platforms with insets (PXLS-7914) to expand training protocol.
- Combination 2-inch round top cross brace and knurled zinc plated pull-up station.
- Standard features include band pegs, all purpose storage hooks, anchor loops, 2" thick pull-up bar, 12-prong weight storage holders and dual Olympic bar storage.

OPTION: PXLS-7914 Olympic platform with inset
(Can accommodate two (2) PXLS-7914)
Weight: 400 lb/181 kg

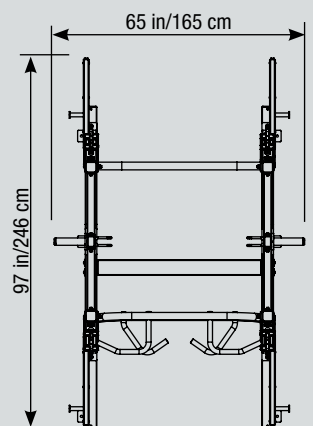

Height: 97 in/246 cm
Weight: 640 lb/290 kg



Olympic bar, weight plates and spring clip collars not included.

PXLS-7930 Power Rack

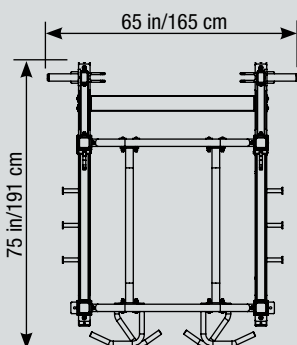

Height: 97 in/246 cm
Weight: 630 lb/286 kg

- Power rack design features adjustable Swing-Lock™ stainless steel bar catches and full length, reinforced Lever Lock™ safety rails rated to 900 lbs. weight capacity.
- Dual 2" fat bar frame connectors double as additional pull-up station.
- Durable-welded knurled zinc plated multi-grip pull-up station for wide, narrow, reverse and neutral grip upper body exercises.
- Standard features include band pegs, all purpose storage hooks, anchor loops, 12-prong weight storage holders and dual Olympic bar storage.

OPTION: PXLS-7915 Olympic platform with inset
Weight: 430 lb/195 kg





Olympic bar, weight plates and spring clip collars not included.

PXLS-7950 Super Rack

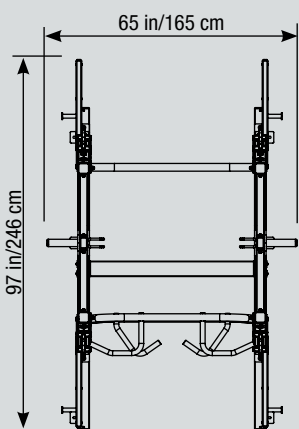

Height: 97 in/246 cm
Weight: 860 lb/390 kg

- Combination of Power Rack and Half Rack design allows multiple exercise participation for up to two users simultaneously.
- Designed to accommodate two (2) Olympic platforms with insets (PXLS-7914 and PXLS-7915) to expand training protocol for up to three users simultaneously.
- Standard features include band pegs, all purpose storage hooks, anchor loops, 2" thick bars, 12-prong weight storage holders and dual Olympic bar storage.

OPTION: PXLS-7915 Olympic platform with inset (as shown)
PXLS-7914 Olympic platform with inset
(Can accommodate two (2) platforms)

Weight: 430 lb/195 kg



Accessories & Platforms

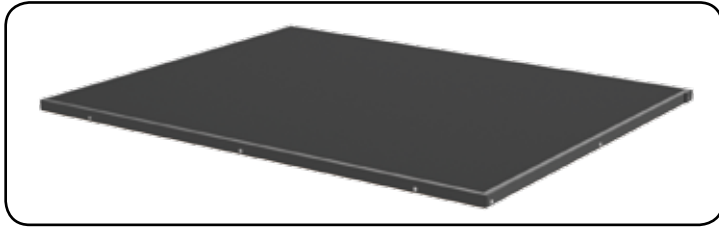

Olympic Platforms – All Rubber

PXLS-7911 6' x 8' Olympic Platform with inset: 7910, 7920 & 7950

PXLS-7912 6' x 8' Olympic Platform with inset: 7930 & 7950

PXLS-7913 6' x 8' Olympic Platform – Free Standing



Olympic Platforms – Oak Wood Center

PXLS-7914 6' x 8' Olympic Platform with inset: 7910, 7920 & 7950

PXLS-7915 6' x 8' Olympic Platform with inset: 7930 & 7950

PXLS-7916 6' x 8' Olympic Platform – Free Standing



PXLS-7994 Horizontal Bumper Rack



PXLS-7996 Spotter Platform (pair)



PXLS-7997 Landmine



PXLS-7998 Dip Attachment
Not available for PXLS-7910 or 7920



PXLS-7999 Dual Bar Catches
Not available for PXLS-7910 or 7920

PXLS-7901 Self-Aligning Adj. Bench
(not shown). Contact your sales
representatives for more information
and availability.

Specifications & Features

- 3"x3" 7-gauge and 2"x3" 11-gauge tubular steel construction.
- Proprietary 8-step electrostatically applied powder coat finish, oven baked to insure durability.
- Deep penetrating electrically welded high strength frames.
- Durable-welded knurled zinc plated multi-grip pull-up station for wide, narrow, reverse and neutral grip upper body exercises.
- Integrated J-hook design (Patent Pending) featuring 1" solid steel Swing Lock™ bar catches.
- 3/4" spring loaded Lever-lock™ pull pins (Patent Pending) on Safety Rails load rated at over 15,000 lbs.
- Swing Lock™ Bar catches and Lever Lock™ Safety Rails adjust in 3" increments to accommodate users of all size.
- Dual fat bar upper frame connectors on Power Rack and Super Rack doubles as additional support and pull-up station.
- 3/8" and 1/2" grade 5 & 8 frame bolts used for optimum strength and durability.
- Heavy duty weight horns provide ample room to store weight plates of all sizes.
- Storage hooks, suspension loops and power band pegs offered as standard features.
- Multiple-layer design, 2" thick platform and inset available with 3/4" solid oak hardwood center or all rubber. Available for all models.
- All frames designed to anchor to floor. Refer to your Owner's Manual for anchoring requirements.

Commercial Warranty*

- 10 YEARS:** Structural frame (coating excluded) and welds.
- 1 YEAR:** Pull-pin components and platform/inset (surface finish excluded). ALL other parts not mentioned, one year from the date of purchase to the original purchaser.
- 90 DAYS:** Platform surface finish, custom platform logo and rubber mat. Finish (applies only to defects from manufacturer only).

* See Owner's Manual for details.

NOTICE: TuffStuff continually engages in research related to product improvement. As a result, the product received by the customer may differ slightly from its published description. Improvements in materials, production techniques and design refinement may at any time be introduced into our products. TuffStuff reserves the right to make changes in its product without notice.



TUFFSTUFF FITNESS EQUIPMENT INC. 13971 Norton Avenue, Chino, CA 91710, USA PH: 909-629-1600 FX: 909-629-4967

info@tuffstuff.net www.tuffstufffitness.com