

Problems with Patterns and Numbers

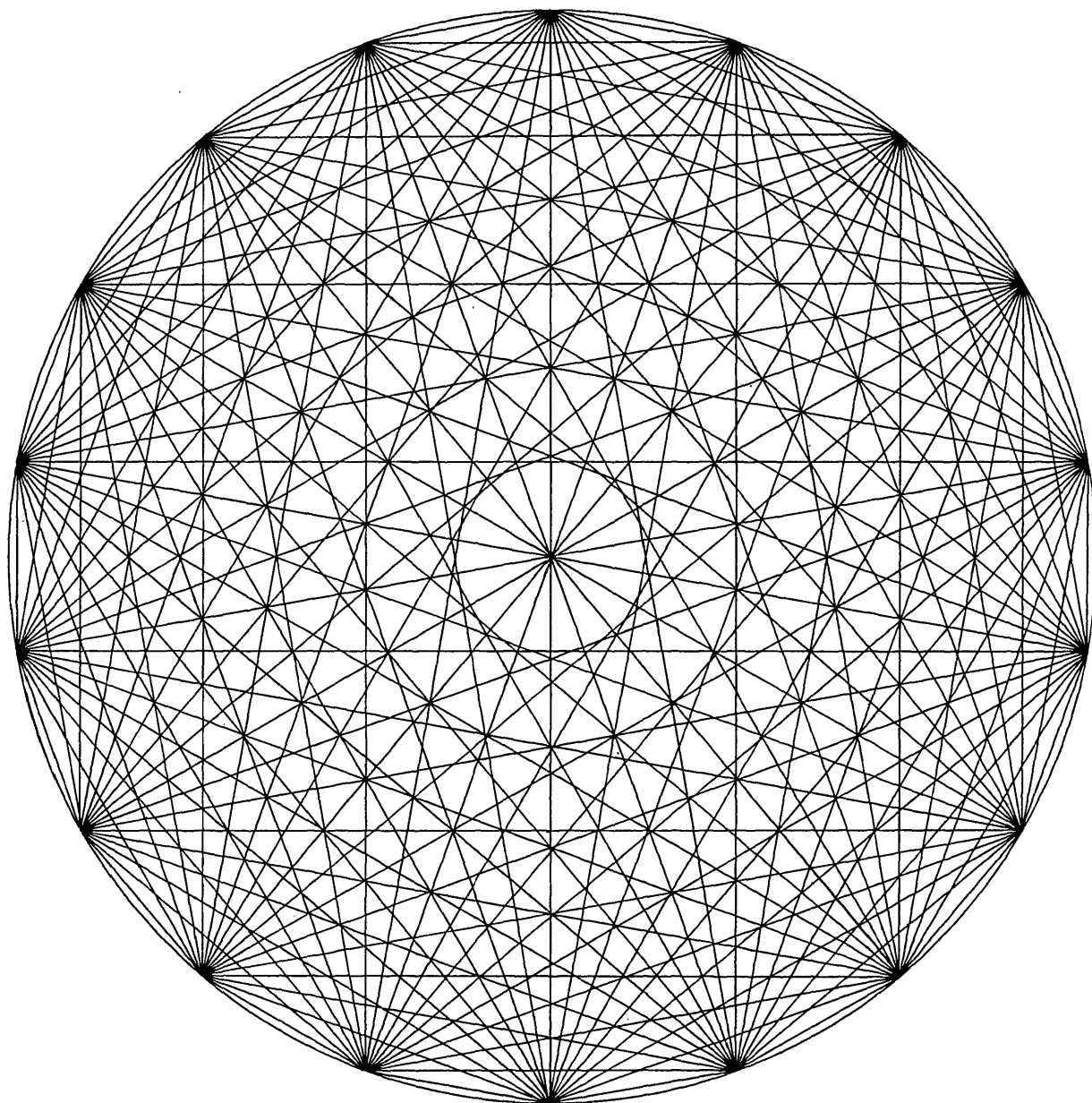

An O-level Module

Joint Matriculation Board
Shell Centre for Mathematical Education

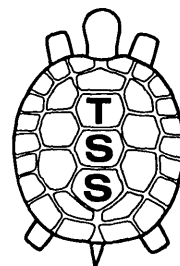

AUTHORS

This Module has been produced by the joint efforts of many teachers working with the Shell Centre for Mathematical Education and the Joint Matriculation Board. It was developed as part of the Testing Strategic Skills programme which aims gradually to promote a balanced range of curriculum activities through the development of new examination questions.

The Module was compiled by the Shell Centre team:

Alan Bell, Barbara Binns, Hugh Burkhardt, Rosemary Fraser, John Gillespie,
David Pimm, Jim Ridgway, Malcolm Swan, Clare Trott,
co-ordinated by Jim Ridgway and Clare Trott, and directed by Hugh Burkhardt.

Specific responsibility for the three sections of the book was as follows:

Specimen Examinations Questions:John Pitts

Classroom Materials:Malcolm Swan

based on the work of a group of teachers, including:

Barbara Binns, Mike Cannon, Alan Chisnall, Kath Cross, Tansy Hardy, Gill Hatch, Cath Mottram, David Wilson and the Shell Centre team, with additional help from

Mark Allen, Anne Baxter, Ray Crayton, Beryl Footman, David Griffiths, Frank Knowles, Mary Robinson, Glenda Taylor

co-ordinated by Susie Groves and Anne Haworth.

Support Materials:Rosemary Fraser

This material has been developed and tested with teachers and pupils in over 30 schools, to all of whom we are indebted, with structured classroom observation by the Shell Centre team.

We gratefully acknowledge the help we have received from:

Paul Morby and the University of Birmingham Television and Film Unit in the making of the video material,

Longman Micro Software, the ITMA Collaboration, the Council for Educational Technology, and the SMILE group of the Inner London Education Authority for the use of the microcomputer materials, and Peter Wilson and his colleagues at the Joint Matriculation Board, together with the staff of Richard Bates Ltd. in the preparation of this Module, and finally Sue Crawford and Sheila Dwyer for much typing and even more patient support.

The book was designed and edited by Malcolm Swan.

Problems with Patterns and Numbers

CONTENTS

Introduction to the Module	6
Specimen Examination Questions	9
Classroom Materials	39
Support Materials	139

An expanded version of the contents follows on the next page . . .

EXPANDED CONTENTS

Introduction to the Module	6
-----------------------------------	---

Specimen Examination Questions	9
<i>Each of these questions is accompanied by a full marking scheme illustrated with sample scripts.</i>	
Contents	10
Introduction	11
“The Climbing Game”	12
“Skeleton Tower”	18
“Stepping Stones”	22
“Factors”	28
“Reverses”	34

Classroom Materials	39
Introduction to the Classroom Materials	41

Unit A

Unit A is the basic core of the Module and should be completed. It will take about one week and contains a full set of worksheets and teaching notes.

Contents	43
Introduction	44
Introductory Problems	45
A1 Organising Problems	46
A2 Trying Different Approaches	50
A3 Solving a Whole Problem	54
Some Solutions	56

Unit B

During Unit B, the intention is to encourage children to solve problems with less help and to articulate and record their different approaches and methods. Four problems, “checklists” of useful strategies for pupils to use when in difficulty, full teaching notes and solutions are provided. This Unit provides roughly one week’s work.

Contents	70
Introduction	71
B1 “Pond Borders”	72
B2 “The First to 100 Game”	76
B3 “Sorting”	80
B4 “Paper Folding”	88

Unit C

Unit C is built around three tasks which differ in style. No printed guidance is offered to the pupils, but the teacher has a list of strategic hints which may be offered to those in difficulty. Solutions are provided. This Unit again occupies roughly one week.

Contents	94
Introduction	95
C1 “Laser Wars”	96
C2 “Kayles”	98
C3 “Consecutive Sums”	100

A Problem Collection

A collection of 15 problems and games to use as a supplement to the materials presented in Units A, B and C. Solutions and ideas for possible extensions are given.

Contents	104
Introduction	105
Problems	106
“Painted Cube, Score Draws, Cupboards, Networks, Frogs, Dots, Diagonals, The Chessboard”	
Games	124
“The Spiral Game, Nim, First One Home, Pin Them Down, The ‘Hot Fat Tune’ Game, Dominoes, The Treasure Hunt”.	

Support Materials

139

These materials are divided into two parts — those that are part of this book, and those that accompany the videotape and microcomputer programs in the rest of the pack. Both are written under the same headings and are usable together or independently. They offer support to individual, or groups of teachers who wish to develop their teaching methodology and explore wider implications of problem solving in the classroom.

Contents	140
Introduction	141
1. Looking at lessons	142
2. Experiencing problem solving	144
3. How much support do children need?	150
4. How can the micro help?	156
5. Assessing problem solving	162

Checklist for the Teacher

Inside back cover

INTRODUCTION TO THE MODULE

This Module aims to develop the performance of children in tackling mathematical problems of a more varied, more open and less standardised kind than is normal on present examination papers. It emphasises a number of specific strategies which may help such problem solving. These include the following:

- * try some simple cases
- * find a helpful diagram
- * organise systematically
- * make a table
- * spot patterns
- * find a general rule
- * explain why the rule works
- * check regularly

Such skills involve bringing into the classroom a rather different balance of classroom activities than is appropriate when teaching specific mathematical techniques; for the pupils, more independent work and more discussion in pairs or groups, or by the whole class; for the teacher, less emphasis on detailed explanation and knowing the answers, and more on encouragement and strategic guidance.

The Module is not concerned with any narrowly defined area of content or mathematical technique within the existing syllabus. Because the strategic skills it focuses on are demanding, it concentrates on the simpler techniques which most pupils will have mastered (e.g. using numbers and discovering simple patterns), while giving credit to those who bring more sophisticated techniques (e.g. algebra) to bear on the problems. A fuller discussion of these aims and the rationale behind the Module follows.

Why problem solving?

The Cockcroft Report† on mathematical education said, in paragraph 243:

“Mathematics teaching at all levels should include opportunities for:

- * exposition by the teacher;
- * discussion between teacher and pupils and between pupils themselves;
- * appropriate practical work;
- * consolidation and practice of fundamental skills and routines;
- * problem solving, including the application of mathematics to everyday situations;
- * investigational work.”

Many teachers would like to include more problem solving and investigational work in the mathematics curriculum. Most do not because they feel under pressure to concentrate on what is on the examination syllabus. They do not feel able to devote

† Mathematics Counts, HMSO 1982.

time to teaching mathematical strategies which are not tested in the examination. Consequently many pupils experience only two of the six elements listed here, exposition and practice. Cockcroft's list was drawn up after a great deal of consultation and consideration of educational research about the way children learn mathematics. This suggested that learning best takes place if the pupil experiences a variety of mathematical activities. The Board recognises that problem solving and investigational work should take place as an essential part of the mathematical curriculum, and that this is likely to happen on a reasonable scale only if these activities are reflected in the assessment procedure. Their importance is already recognised in the Board's current examination objectives, particularly the later ones in the list:

Knowledge and abilities to be tested

The following list is intended to provide a general indication of the knowledge and abilities which the examination will be designed to test.

1. Knowledge of mathematical notation, terminology, conventions and units. The language and notation of sets together with the ideas of a mapping and a function are basic to the syllabus.
2. The ability to understand information presented in verbal, graphical or tabular form, and to translate such information into mathematical form.
3. The ability to recognise the mathematical methods which are suitable for the solution of the problem under consideration.
4. The ability to apply mathematical methods and techniques.
5. The ability to manipulate mathematical expressions.
6. The ability to make logical deductions.
7. The ability to select and apply appropriate techniques to problems in unfamiliar or novel situations.
8. The ability to interpret mathematical results.

However, the types of questions currently set do not adequately test these higher level skills. This Module will allow the introduction of an appropriate question into the examination in a way that is accessible to the teachers and pupils that the Board serves. To ensure this, the Module offers teachers classroom material which has been carefully developed and tested, and teacher support materials, as well as detailed information about the change in the examination itself. These three elements of the Module: specimen examination questions and marking schemes with pupil answers, sample classroom materials and support materials will, we hope, give a clear picture of the intentions. The successive trials of the Module have shown that they offer a straightforward way to realise those intentions.

Specimen Examination Questions

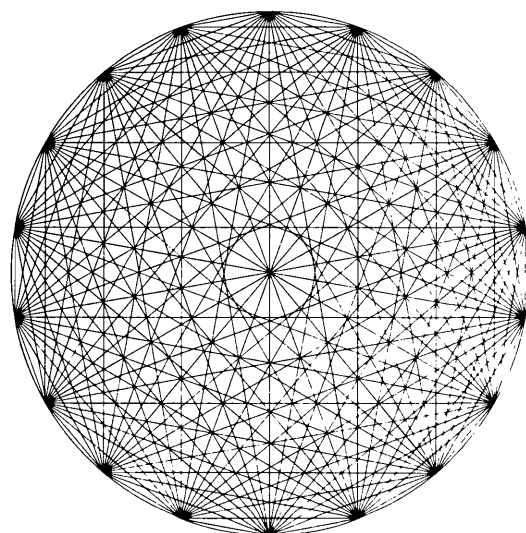

Specimen Examination Questions

CONTENTS

Introduction		11
<hr/>		
Questions	The Climbing Game	12
	Skeleton Tower	18
	Stepping Stones	22
	Factors	28
	Reverses	34

INTRODUCTION

This Module introduces a somewhat new type of examination question in which the mathematical processes involved, especially the choice and explanation of strategies and discussion of results, are as important as the answers obtained. This is reflected in the marking schemes.

The questions set will be drawn from a wide variety of problems which are loosely linked under the heading “Patterns and Numbers”. The range of problems is not defined in the conventional way by specifying a topic area or listing the mathematical techniques involved. Instead, the problems will involve situations in which, starting from the consideration of some particular cases, a pattern has to be found and then formulated into a general rule. These processes are important throughout mathematics and number properties and patterns provide a suitable field in which they can be developed.

It should be noted that, in the examination, candidates will be given credit for explanations of what has been attempted at each stage and for what has been discovered. More generally, mark schemes will be designed to give credit for:

- (i) showing an understanding of the problem,
- (ii) organising information systematically,
- (iii) describing and explaining the methods used and the results obtained,
- (iv) formulating a generalisation or rule, in words or algebraically.

The following sample of questions gives an indication of the variety likely to occur in the examination. Sample marking schemes and their application to sample answers are provided. The marks given here indicate the proportion of credit assigned for the various parts of a question out of a total of 10 marks. In the examination the total mark given for a particular question will depend on its length and on where it appears in the question paper. Each of the questions in this sample would take up about 20 minutes of examination time.

THE CLIMBING GAME

This game is for two players.

A counter is placed on the dot labelled “start” and the players take it in turns to slide this counter up the dotted grid according to the following rules:

At each turn, the counter can only be moved to an *adjacent* dot *higher* than its current position.

Each movement can therefore only take place in one of three directions:

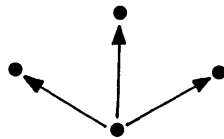

The first player to slide the counter to the point labelled “finish” wins the game.

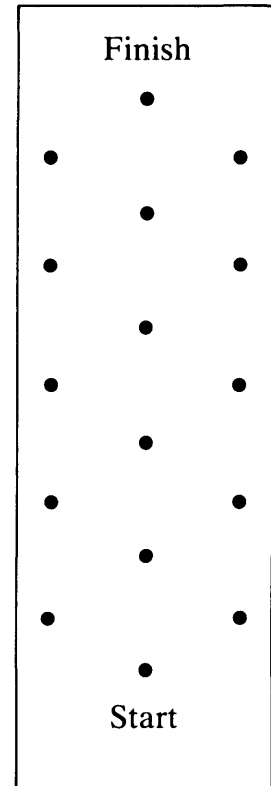

- (i) This diagram shows the start of one game, played between Sarah and Paul.

Sarah’s moves are indicated by solid arrows (—→)

Paul’s moves are indicated by dotted arrows (---→)

It is Sarah’s turn. She has two possible moves.

Show that from one of these moves Sarah can ensure that she wins, but from the other Paul can ensure that he wins.

- (ii) If the game is played from the beginning and Sarah has the first move, then she can always win the game if she plays correctly.

Explain how Sarah should play in order to be sure of winning.

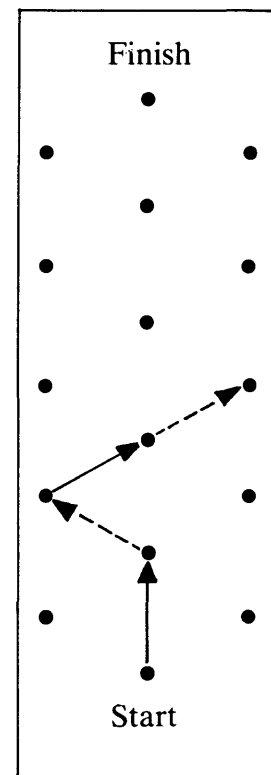

THE CLIMBING GAME . . . MARKING SCHEME

- (i) **Showing an understanding of the rules of the game by systematically dealing with the various possible moves.**

1 mark for indicating that Sarah can force a win by moving to point A or for indicating that she could lose if she moves to point B.

2 marks for a correct analysis of the situation if Sarah moves to point A including the consideration of both of Paul's possible moves.

Part mark: 1 mark for an incomplete or unclear analysis.

3 marks for considering the situation if Sarah moves her counter to point B and making a correct analysis.

Part marks: 2 marks for an analysis which is complete but unclear or which is clear but omits to consider one of the two possible moves for Sarah from point A or C. 1 mark for a more partial analysis.

- (ii) **Formulating and explaining a winning strategy for the game**

4 marks for clear, complete and correct explanation.

Part marks: 3 marks for incomplete or unclear but correct explanation.

Up to 3 marks can be given for the following:

1 mark for recognition of symmetry.

1 mark for evidence of a systematic approach.

1 mark for correctly identifying some winning and/or losing positions above line m .

or 2 marks for correctly identifying some winning and/or losing positions below line m (or above and below line m).

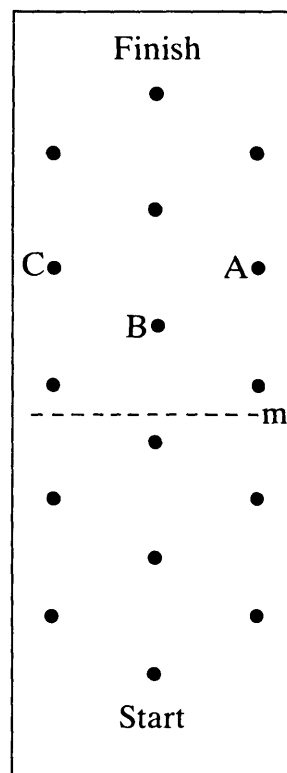

The Climbing Game

Angela

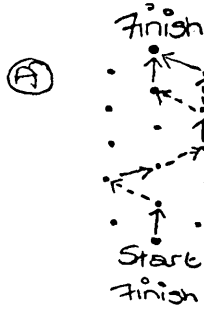

(A)

If Sarah goes up here, Paul has two choices of which way he could go. Whichever he chooses, Sarah would still win.

(B)

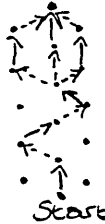

If she goes across here, it is possible for her to win if Paul goes upwards, but any other way to the side + he would win.

If Sarah goes up as in (A) it is sure that she would win.

If Sarah went across as in (B), as long as he didn't go upwards, Paul would win.

The climbing game

Daren

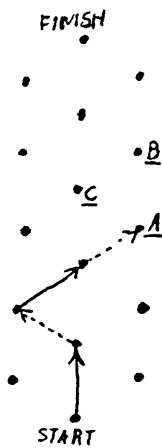

This is the start of the game between Sarah and Paul. Sarah's moves are indicated by the solid lines, and Paul's moves are indicated by the dotted arrows. From this position, Sarah can ensure a win or ensure that Paul wins. If she moves to point B, she will win, because no matter where Paul then moves, it will leave Sarah with just one move to make to the finish. If she moves to point C, she will ensure herself of defeat because she will put Paul in the winning position.

The following examples exhibit various features of the marking scheme.

Part (i) Marking Incomplete Analyses

Both Angela and Darren gain 3 marks (out of a possible 3) for correctly analysing the situation if Sarah moves vertically upwards. In the case when Sarah moves diagonally upwards both candidates produced incomplete analyses. However Angela's analysis is only lacking in the consideration of the case illustrated below:–

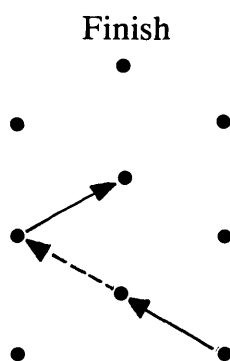

Her analysis would be awarded 2 marks out of the possible 3 marks.

Darren's analysis does not explain why Sarah's move to the point Darren labels "C" puts Paul in a winning position. This is less complete than Angela's analysis and is awarded 1 mark out of the possible 3 marks.

Stevem

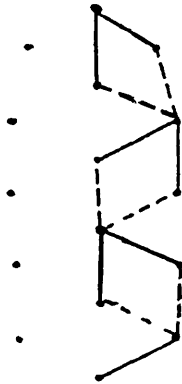

I've shown both routes that Paul can take from Sarah's moves and he can't win.

The dark ones are Sarah
 The light dotted ones are Paul
 This way Sarah can't lose
 Sarah can also win on the
 other side as well.

Finish

Michael

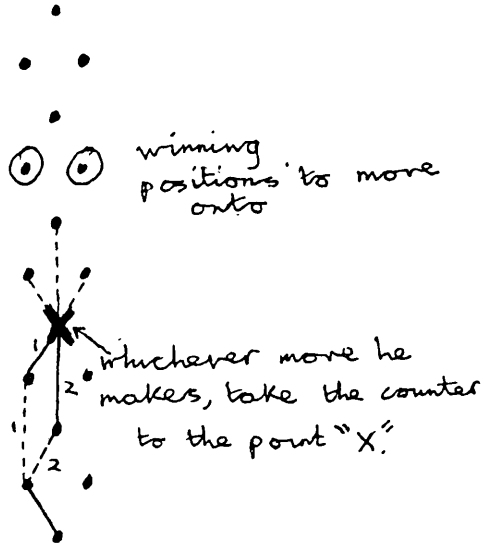

2) If ~~you~~ starts first then ~~you~~ should take the line ~~to the next point~~ ^{left or right} to the next point. Wherever he moves, take the line to the cross on the diagram. He has a choice of 3 moves, whichever one it is, take the line to ~~any~~ ^{any} spot marked O. From here he will play the counter to a point adjacent to the Finish and you have won!

Part (ii) Marking Explanations

Explanations can be given using diagrams or verbal descriptions, or a combination of the two.

Steven's explanation is almost entirely diagrammatic. His diagram shows the moves that Sarah must make and two alternative moves that Paul can make at each stage. The cases which are not covered by the diagram follow from the symmetry of the situation and this is implied by Steven's statement: "Sarah can also win on the other side as well!"

By contrast Michael's explanation is more verbal. Whereas Steven considers sequences of moves from start to finish, Michael identifies winning positions, which he clearly defines as positions he moves *onto*.

(Some other candidates may use an alternative definition of "winning positions" as points *from* which you can win if it is your turn to move.)

Both Steven and Michael are awarded the full 4 marks for their explanations.

SKELETON TOWER

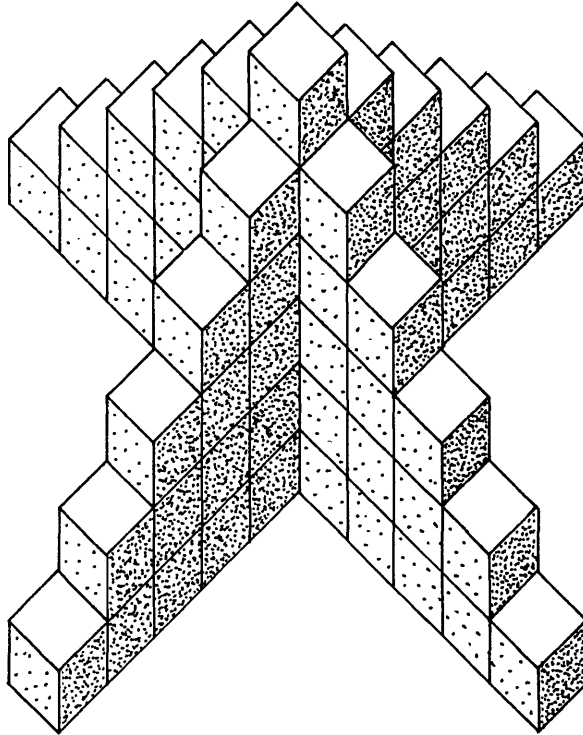

- (i) How many cubes are needed to build this tower?
- (ii) How many cubes are needed to build a tower like this, but 12 cubes high?
- (iii) Explain how you worked out your answer to part (ii).
- (iv) How would you calculate the number of cubes needed for a tower n cubes high?

SKELTON TOWER . . . MARKING SCHEME

- (i) **Showing an understanding of the problem by dealing correctly with a simple case.**

Answer: 66

2 marks for a correct answer (with or without working).

Part mark: Give 1 mark if a correct method is used but there is an arithmetical error.

- (ii) **Showing a systematic attack in the extension to a more difficult case.**

Answer: 276

4 marks if a correct method is used and the correct answer is obtained.

Part marks: Give 3 marks if a correct method is used but the work contains an arithmetical error or shows a misunderstanding (e.g. 13 cubes in the centre column).

Give 2 marks if a correct method is used but the work contains two arithmetical errors/misunderstandings.

Give 1 mark if the candidate has made some progress but the work contains more than two arithmetical errors/misunderstandings.

- (iii) **Describing the methods used.**

2 marks for a correct, clear, complete description of what has been done providing more than one step is involved.

Part mark: Give 1 mark if the description is incomplete or unclear but apparently correct.

- (iv) **Formulating a general rule verbally or algebraically.**

2 marks for a correct, clear, complete description of method.

Accept “number of cubes= $n(2n-1)$ ” or equivalent for 2 marks. Ignore any errors in algebra if the description is otherwise correct, clear and complete.

Part mark: Give 1 mark if the description is incomplete or unclear but shows that the candidate has some idea how to obtain the result for any given value of n .

Angela.

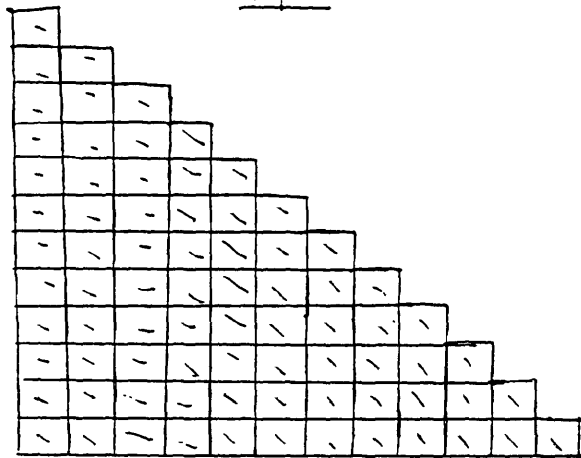

$$\begin{array}{r} 78. \\ \times 4 \\ \hline 292 \\ 13 \\ \hline 305 \end{array}$$

or: $12 \times 12 = 144$
 $144 - 78 = 66$

2. 305 cubes are needed to build a tower 12 cubes high.

3. 2d diagram, shows 78 cubes.

multiplied 78 by 4, = 292.

added to middle column of cubes

no of ^{middle} cubes = 13

no of cubes = 292.

$$\begin{array}{r} \therefore 292 \\ + 13 \\ \hline = 305 \end{array}$$

Karen

3). I took the number of cubes high it was, ~~the~~ wrote down the number eg 4 then 1 times all the other numbers down to 0 by 4

example 1

4 cubes high

$$4 + (3 \times 4) + (4 \times 2) + (4 \times 1) = 28$$
$$4 + 12 + 8 + 4 =$$

example 2

9 cubes high

$$9 + (8 \times 4) + (7 \times 4) + (6 \times 4) + (5 \times 4) + (4 \times 4) + (3 \times 4) + (2 \times 4) + (1 \times 4) = 153$$
$$9 + 32 + 28 + 24 + 20 + 16 + 12 + 8 + 4$$

Part (ii) Marking Errors and Misunderstandings

Notice that “ $12 \times 12 = 144$ ” is not pursued and does not affect the marking. In Part (ii) of the problem, Angela shows a misunderstanding — her diagram shows one wing of the tower to be 12 cubes \times 12 cubes instead of 11 cubes \times 11 cubes. Indeed her calculations confirm this ($78 \times 4 + 13$) and she also makes an arithmetic error ($78 \times 4 = 292$) so she is only awarded 2 out of the 4 possible marks here.

Part (iii) Comparing Two Descriptions

In Part (iii) Angela clearly explains how she worked out her answer. This explanation, although still containing both the misunderstanding and the arithmetic slip, is clear, complete and correctly explains *her* method. Angela is, therefore, awarded both marks for this part of the problem.

In contrast, Karen’s description of how she worked out the answers is incomplete although fairly clear and correct. The examples she quotes are a useful illustration but the description should include the final summation. Karen scores 1 mark out of 2 for her description. Her examples also go some way towards answering part (iv), and she is therefore credited with 1 mark for part (iv).

STEPPING STONES

A ring of “stepping stones” has 14 stones in it, as shown in the diagram.

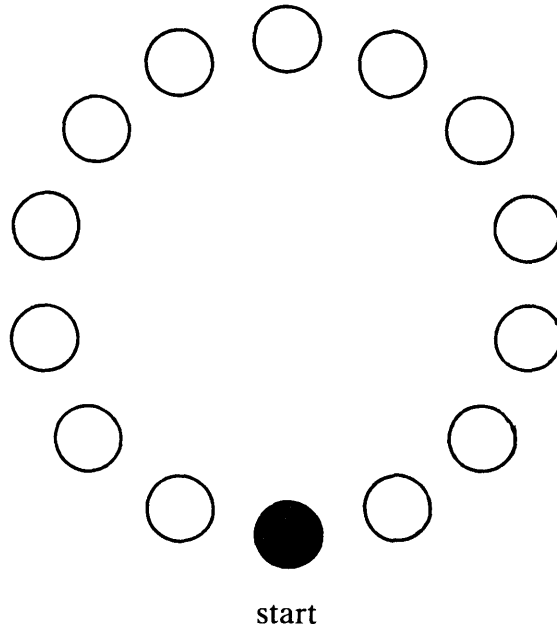

A girl hops round the ring, stopping to change feet every time she has made 3 hops. She notices that when she has been round the ring three times, she has stopped to change feet on each one of the 14 stones.

- (i) The girl now hops round the ring, stopping to change feet every time she has made 4 hops. Explain why in this case she will not stop on each one of the 14 stones no matter how long she continues hopping round the ring.
- (ii) The girl stops to change feet every time she has made n hops. For which values of n will she stop on each one of the 14 stones to change feet?
- (iii) Find a general rule for the values of n when the ring contains more (or less) than 14 stones.

STEPPING STONES . . . MARKING SCHEME

(i) Showing an understanding of the problem through explaining a simple case.

3 marks for a clear, correct and complete explanation.

Part marks: Give 2 marks for an incomplete but otherwise clear and correct explanation.

In other cases 1 or 2 marks may be gained by mentioning one or two of the following:

- (a) Evenness or common factor 2;
- (b) After going twice round, the girl returns to the starting stone;
- (c) The girl stops on 7 of the 14 stones (or every other stone).

(ii) Considering other cases and organising the information.

4 marks for $n=3, 5, 9, 11, 13$ (condone the omission of 1 and values of n greater than 14).

Part marks: Give 3 marks if the solution contains one error (e.g. includes 2 or omits 11) but $n=7$ is clearly rejected.

Give 2 marks for at least three correct values of n with $n=7$ clearly rejected.

Give 1 mark for one correct value of n (other than $n=1, n=3$) or a correct general statement such as “ n must be an odd number”.

(iii) Generalising by considering further cases and formulating a rule.

1 mark for considering case(s) with more (or less) than 14 stones.

2 marks for a general rule which is clear, correct and complete.

Part mark: Give 1 mark for a general rule which is apparently correct but not very clear.

Teresa

(1) When the girl hops round and lands on every fourth stone and changes feet she will not land on every stone. She will not land on every stone because the number of stones she jumps over and lands and changes feet are is 4 and four is an even number and it will not work on an even number because there is an even number of stones.

There is a pattern to this it will not work for any even number because there is a pattern like land on one, miss the next and land on the next.

Andy

2) $n = 1, 3, 5, 7, 11, 13, 15, 17, 19, 23$

$n =$ prime numbers (~~except 7~~) and
(except 7 as it goes into 14)
(exactly twice ~~3~~)

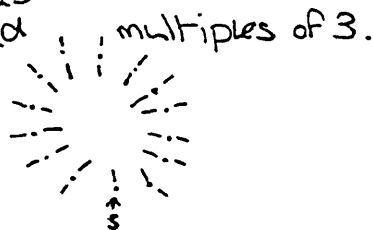

Catriona

2) she will stop on every stone if she makes:

1 hop

3 hops

5 hops

15 hops

Part (i) Marking Explanations

Teresa's explanation contains two important ingredients; the statement that "it will not work on an even number" and secondly she notes that the pattern is "land on one, miss the next and land on the next". However, she does not indicate that this is because after twice round the ring she will land on the "start" stone again; she is therefore awarded 2 marks out of a possible 3 for a clear, correct but incomplete explanation.

Part (ii) Finding Possible Values of n

In Part (ii) Andy clearly rejects 7 but omits 9 also. He is awarded 3 marks out of 4. On the other hand from what Catriona writes, it is not clear that 7 has been considered and rejected. She is awarded 1 mark for $n=5$. ($n=3$ was given in the problem statement, $n=1$ is trivial and values of n greater than 14 are disregarded).

Catrina

iii) As the ring contains 14 stores, she wants to go round the ring and end up on the one next to the one she started on every time, so that in this case she should do a number of hops that will divide by 15, as that is one more than 14, so she would end up on the stone next to the one she started on. After going ~~the~~ round the circle the number of times that it is before she changes feet she should have landed on all the stores.
eg.

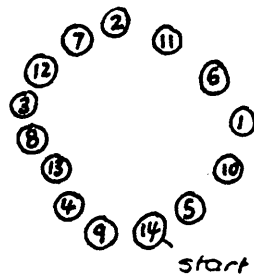

If a ring contained 8 stores, she would have to do a number of hops that would divide by 9 and go round that many times, for example 3.

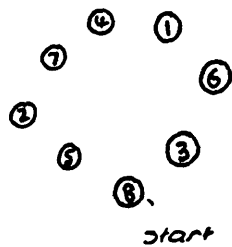

This would work for a ring of any size, even a prime number because this ring will divide eg. by itself or 1.

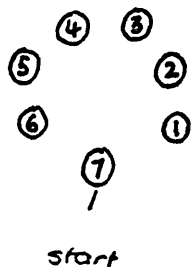

Part (iii) An Incomplete Generalisation

Catriona clearly considers cases where the number of stones is *not* 14. She finds in each case some possible values of n , but not all. What she writes is clear and correct but incomplete and so she scores 2 marks out of the possible 3.

FACTORS

The number 12 has six factors: 1, 2, 3, 4, 6 and 12.

Four of these are even (2, 4, 6 and 12)

and two are odd (1 and 3).

- (i) Find some numbers which have all their factors, except 1, even.
Describe the sequence of numbers that has this property.

- (ii) Find some numbers which have exactly half their factors even. Again
describe the sequence of numbers that has this property.

Explain in both part (i) and part (ii) why your result is true.

FACTORS . . . MARKING SCHEME

- (i) **Showing an understanding of the problem by dealing successfully with some simple cases.**

Answer: 2, 4, 8, 16, 32 . . .

2 marks if the examples given show that the candidate has the right idea (for example 8, 16).

Part mark: Give 1 mark if it is not clear that the candidate has the right idea but correct examples are given (e.g. 2, 4)
or if at least three numbers are examined and the correct conclusion is reached about them (including at least one number with the given property).

Organising the relevant information, seeing and describing a pattern

3 marks for a description which is clear, complete and correct.

Part marks: Give 2 marks if the description is clear, correct but incomplete
or if the description is clear and complete but of a set of numbers which is not quite correct.

Give 1 mark if the description is not very clear but indicates that the candidate has some idea.

Explaining the results obtained

1 mark for an explanation of why the numbers in the set the candidate has obtained have the given property.

- (ii) **Showing an understanding of the problem by dealing successfully with some simple cases.**

Answer: 2, 6, 10, 14, 18 . . .

1 mark if examples show that the candidate has the right idea.

2 marks for a description which is clear, complete and correct.

Part mark: Give 1 mark if the description is clear and correct but incomplete
or if the description is clear and complete but of a set of numbers which is not quite correct.

1 mark for an explanation of why the numbers in the set the candidate has obtained have the given property.

NOTE If it is to the candidate's benefit, give (2+3+1) marks to part (ii) and (1+2+1) marks to part (i).

Rebecca

2(i) numbers with all factors except 1, even:

2, 4, 8, 16, 20, 24, 28, 32
+2 +4 +8 +4 +4 +4 +4

The numbers go up, adding the number which has just been found out.

eg. $2+2=4$, $4+4=8$, $8+8=16$

When the amount gets to 20, you go back to adding 4.

eg. $16+4=20$, $20+4=24$, $24+4=28$, $28+4=32$

Ivan

FACTORS

$16 = 2, 4, 8, 16$ ✓ 16 has all even factors.

$20 = 2, 4, 5, 10, 20$ ✗ 20 has 1 odd factor 5.

$18 = 2, 3, 6, 9, 18$ ✗ 18 has 2 odd factors

$40 = 2, 4, 5, 8, 10, 20, 40$ ✗ 40 has 1 odd factor.

$24 = 2, 4, 6, 8, 12, 24$ ✓ 24 has all even factors.

Steven

2. Numbers with half of factors even

6	6, 3, 2, 1
10	5, 2, 1, 10
14	14, 7, 2, 1
18	3, 6, 9, 2, 1, 9

All numbers that we double an odd number have the same number of odd and even factors

This is true because an odd number e.g. 3 has only odd factors if the number is doubled then $3 \times 2 = 6$ then its number of factors also doubles e.g. 3 has two factors 1, 3
6 " four " 1, 3, 2, 6.

Part (i) Marking Sets of Factors

Rebecca is awarded 3 marks out of the possible 5 for this section, although her answer contains errors. The set she gives should not include the numbers 20, 24 and 28 but she appears to have the right idea. For this set she scores 1 mark out of 2. She then correctly and clearly describes the set she has found and is credited with 2 marks out of 3 for this, as it is “clear and complete but of a set of numbers which is not quite correct”.

Ivan has correctly given 16 and correctly rejects the numbers 20, 18 and 40, and although he makes an error by including 24, he clearly considers several cases and demonstrates an understanding of the problem. For this he is awarded 1 mark out of 2.

Marking Explanations

Steven’s answer to this part of the problem is correct and complete and his explanations and examples are clear. He is awarded full marks.

Mandip

2 is double 1 so it has all the factors 1 has plus the same factors doubled e.g.

$$1 = 1$$
$$2 = 1 \text{ and } 2$$

4 has all the factors of 2 plus the factors of 2 doubled.

$$2 = 1, 2$$
$$4 = 1, 2, 4$$

We know that when an even number is doubled, you get even numbers, so when the even factors of numbers are doubled you get even factors of the next number. This means when you double a number, with even factors, the result will also have even numbers.

- 2) $3 = 1, 2$ 1=odd, 2=even
 $6 = 1, 2, 3, 6$ 2+6 even, 1+3 odd.
18 =
etc.

Any number which has $\frac{1}{2}$ even factors and $\frac{1}{2}$ odd factors is trebled to get another number with the same property.

This is because:-

When an odd number is trebled, it results in an odd number. When an even number is trebled, it results in an even number.

So when all the even factors and odd factors of a number are trebled, the result is the same proportion of even factors to odd.

So when a number which has $\frac{1}{2}$ even and $\frac{1}{2}$ odd factors is trebled, it results in a number which has all the ~~same~~ ~~same~~ the ~~same~~ same factors plus those factors trebled. So:-

$$3 = 1, 2$$
$$6 = 1, 2, 3, 6$$
$$18 = 1, 2, 3, 6, 9, 18$$

This shows the pattern.

This extract shows the second page of Mandip's excellent attempt at tackling the "Factors" problem.

His two explanations are of a very high quality. However, his second explanation is incomplete because he does not consider the numbers common to the original factors and these factors trebled. He therefore lost the mark for the second explanation. (Overall, Mandip was awarded 8 marks out of a possible 10 for the whole question).

REVERSES

Here is a row of numbers: 2, 5, 1, 4, 3.

They are to be put in ascending order by a sequence of moves which reverse chosen blocks of numbers, *always starting at the beginning of the row.*

Example:

<u>2, 5, 1, 4, 3</u>	reversing the first 4 numbers gives	4, 1, 5, 2, 3
<u>4, 1, 5, 2, 3</u>	reversing the first 3 numbers gives	5, 1, 4, 2, 3
<u>5, 1, 4, 2, 3</u>	reversing all 5 numbers gives	3, 2, 4, 1, 5
.		
.		
.		
.		
1, 2, 3, 4, 5		

- (i) Find a sequence of moves to put the following rows of numbers in ascending order
- (a) 2, 3, 1
 - (b) 4, 2, 3, 1
 - (c) 7, 2, 6, 5, 4, 3, 1
- (ii) Find some rules for the moves which will put any row of numbers in ascending order.

REVERSES . . . MARKING SCHEME

(i) **Showing an understanding by dealing successfully with simple cases**

(a) *2 marks* for $231 \rightarrow 321 \rightarrow 123$ (or any correct solution).

(b) *2 marks* for $4231 \rightarrow 1324 \rightarrow 3124 \rightarrow 2134 \rightarrow 1234$ (or any correct solution).

Showing a systematic attack in the extension to a more difficult case

(c) *3 marks* for $7265431 \rightarrow 1345627 \rightarrow 6543127 \rightarrow 2134567 \rightarrow 1234567$ (or any correct solution).

Part marks: Give 2 marks if the solution is basically correct but contains an error (e.g. in transcribing numbers).

Give 1 mark if the solution is incomplete but there is an intention to collect numbers . . . 567 or . . . 321 at the right hand end.

(ii) **Formulating some general rules; describing and explaining them**

1 mark for saying that the highest (or lowest) number is to be brought to the right hand end.

1 mark for saying how this is done.

1 mark for completing the description of the method.

For this example we give two complete marked answers, followed by some additional comments.

Jane

Marks.

- Reverses.
- 2) a) 2, 3, 1 reversing the first two numbers gives 3, 2, 1.
 3, 2, 1 reversing the ~~first~~ three numbers gives 1, 2, 3. 2
- b) 4, 2, 3, 1 reversing the first three numbers gives 3, 2, 4, 1
 3, 2, 4, 1 reversing the first two numbers gives 2, 3, 4, 1 2
 2, 3, 4, 1 reversing the first three numbers gives 4, 3, 2, 1.
 4, 3, 2, 1 reversing ~~the~~ all four numbers gives 1, 2, 3, 4.
- c) 7, 2, 6, 5, 4, 3, 1 reversing the first ~~four~~ numbers gives 5, 6, 2, 7, 4, 3, 1.
 5, 6, 2, 7, 4, 3, 1 reversing the first five numbers gives 4, 7, 2, 6, 5, 3, 1
 4, 7, 2, 6, 5, 3, 1 reversing the first three numbers gives 2, 7, 4, 6, 5, 3, 1
 2, 7, 4, 6, 5, 3, 1 reversing the first six numbers gives 3, 5, 6, 4, 7, 2, 1 3
 3, 5, 6, 4, 7, 2, 1 reversing the first five numbers gives 7, 4, 6, 5, 3, 2, 1.
 7, 4, 6, 5, 3, 2, 1 reversing the first two numbers gives 4, 7, 6, 5, 3, 2, 1
 4, 7, 6, 5, 3, 2, 1 reversing the first four numbers gives 5, 6, 7, 4, 3, 2, 1
 5, 6, 7, 4, 3, 2, 1 reversing the first three numbers gives 7, 6, 5, 4, 3, 2, 1.
 7, 6, 5, 4, 3, 2, 1 reversing all seven numbers gives 1, 2, 3, 4, 5, 6, 7
- 2, Always try to get the numbers working so 1 is at the furthest end, then get 2 next to it and so on, then finally you can reverse all the numbers to make them ascending 2

9

Jane

- (i) (a) and (b) are both correct, concise solutions. Jane's solution to part (c) is not as short as it could be, but is correct and so she is awarded all 3 marks.
- (ii) Jane's explanation is incomplete because she does not explain how the numbers can be collected at the furthest end, so she does not gain the second set of 3 marks available here.

ANDREW

REVERSES

Marks

1) a)	2, 3, 1 3, 2, 1 1, 2, 3	REVERSE 1 st 2 REVERSE ALL 3	2
b)	4, 2, 3, 1 2, 4, 3, 1 3, 4, 2, 1 4, 3, 2, 1 1, 2, 3, 4	REVERSE 1 st 2 REVERSE 1 st 3 REVERSE 1 st 2 REVERSE ALL 4	2
c)	7, 2, 6, 5, 4, 3, 1 4, 5, 6, 2, 7, 3, 1 6, 5, 4, 2, 7, 3, 1 7, 2, 4, 5, 6, 3, 1 1, 3, 6, 5, 4, 2, 7 3, 6, 5, 4, 2, 7, 1 4, 5, 6, 3, 2, 7, 1 7, 2, 3, 6, 5, 4, 1 3, 2, 7, 6, 5, 4, 1 2, 3, 7, 6, 5, 4, 1 3, 7, 6, 5, 4, 1, 2 7, 6, 5, 4, 1, 2, 3 4, 5, 6, 7, 1, 2, 3 5, 6, 7, 1, 2, 3, 4 6, 7, 1, 2, 3, 4, 5 7, 1, 2, 3, 4, 5, 6 1, 2, 3, 4, 5, 6, 7	REVERSE 1 st 5 REVERSE 1 st 3 REVERSE 1 st 5 REVERSE ALL 7 REVERSE 1 st 1 REVERSE 1 st 4 REVERSE 1 st 6 REVERSE 1 st 3 REVERSE 1 st 2 REVERSE 1 st 1 REVERSE 1 st 1 REVERSE 1 st 4 REVERSE 1 st 1 REVERSE 1 st 1 REVERSE 1 st 1 REVERSE 1 st 1	0

(4)

Andrew

- (i) (a) and (b) are both correct, concise solutions. Andrew's solution to part (c) contains a serious error. Whenever he says "reverse 1st 1" he transfers the first digit to the right hand end. This is not a transcription error, but an error in method and so no marks are awarded.

(Andrew does not attempt part (ii) of the question).

Classroom Materials

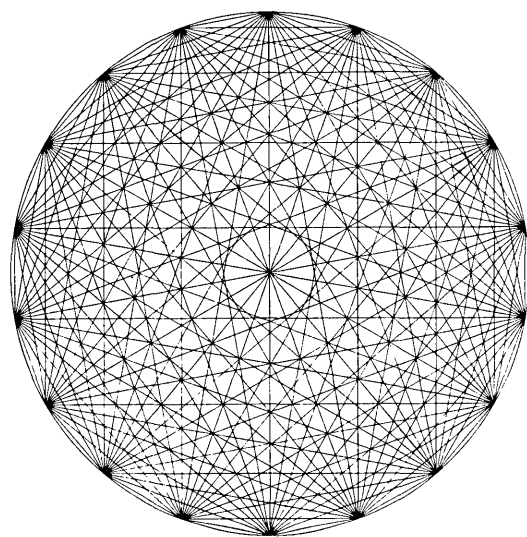

Classroom Materials

INTRODUCTION

These offer some resources by which pupils can be prepared for the questions on the examination. All the materials and suggestions are offered in the explicit recognition that every teacher will work in their own classroom in their own individual way.

The aims of the material are to develop and give pupils experience in

- * solving easy unfamiliar problems
- * a number of specific strategic skills, with practice in trying these strategies on a range of harder problems, many of which respond to them
- * reflecting on, discussing and explaining in writing both their approach to the problem, and their discoveries.

The classroom material is organised as three Units (A, B and C, each of which is intended to support roughly one week's work), together with a problem collection providing supplementary material for the quicker student, or for revision. Through the three Units, the guidance provided to the pupils is gradually decreased so that by the end they are facing challenges similar to those presented by the examination questions.

Unit A consists of a series of worksheets based around a set of problems, which aim to teach a number of powerful problem solving strategies, and demonstrate their “pay off”.

Unit B gives the pupil less guidance, now in the form of “checklists” which contain a list of strategic hints. It is intended that these “checklists” should only be offered to pupils who are in considerable difficulty or later as a stimulus for reflective discussion. The problems in this Unit respond to similar strategies to those introduced in Unit A, but begin to vary in style. In particular, one task involves the strategic analysis of a simple game.

Unit C is built around three tasks which differ in style, but which again respond to similar problem solving strategies. No printed guidance is offered to pupils, but the teacher has a “checklist” of strategic hints which may be offered orally to pupils in difficulty.

The Problem Collection provides supplementary material at any stage for those pupils who move rapidly—though because many of the problems in the Units are open and allow various extensions, able pupils will continue to find challenges in them if encouraged to do so.

You will find it helpful to look at the **Support Materials** and to work through them with your colleagues if possible; they are in a section at the end of this book.

In this Module all pupil materials are “framed” and it is assumed that calculators will be available throughout.

Notes for the teacher in each Unit provide specific teaching suggestions. Inside the back cover is a Checklist of suggestions on managing and coaching open learning activities, which have been found helpful. As we emphasised at the beginning, all the teaching suggestions are offered in the recognition that every teacher will work in their classroom in their own individual way. We have found that it is helpful to make clear what we intend by offering explicit detailed suggestions for teachers to choose from and to modify. This has also enabled us to present materials which we have seen working well in a representative range of classrooms.

Unit A

CONTENTS

Introduction		44
<hr/>		
Introductory problems		45
<hr/>		
A1 Organising Problems	Pupil's booklet	46
	Teaching notes	47
<hr/>		
A2 Trying Different Approaches	Pupil's booklet	50
	Teaching notes	51
<hr/>		
A3 Solving a Whole Problem	Pupil's booklet	54
	Teaching notes	55
<hr/>		
Some Solutions	The Tournament	56
	Mystic Rose	58
	Money	60
	Town Hall Tiles	62
	Flower Beds	64
	House of Cards	66

INTRODUCTION

This Unit aims to introduce pupils to tackling unfamiliar problems and to develop their strategic skills. If any of the examples have already been covered by the class, other problems from later Units in the Module, from the Problem Collection or elsewhere should be substituted. Equally, previous experience of investigative work in mathematics may indicate that some variation in the use of this material will be needed.

The objectives of the “Introductory Problems” are to give pupils an opportunity to experience and struggle unaided with a different kind of mathematical activity, to build confidence that problem solving may not always be difficult, and also to show that it often is! Thus pupils should succeed on the first problem*, make considerable headway with the second but make little progress with the third problem. During this activity, the teacher should not offer any help whatsoever, and this may be made easier in a test-like atmosphere. This is only an introduction and should not occupy more than one hour at most.

The first worksheet in Unit A introduces a variety of strategies and shows their usefulness on a very similar problem to the final one in the introductory activity. The remaining worksheets show that similar strategies also work on other problems and that even problems which on the surface appear to be completely different can be remarkably similar in structure.

The second worksheet invites pupils to compare several very different approaches to a problem and comment on their respective advantages and disadvantages.

The final worksheet presents two complete problems that can be tackled with similar strategies, and asks pupils to describe the way they approach them, and to extend them in some way.

Important Note

Every page of pupil material is surrounded by a frame. In this book, some of this material has been reduced to half size; full size “masters” for photocopying are included separately. In Unit A, worksheets A1 to A3 are intended to be printed back to back on a single sheet of A₄ paper, and then folded into a small four-sided A₅ booklet.

*Calculators, though not essential, enhance the “Target” problem. Teachers should be aware that differences in calculator “logic” may affect the solutions to this problem.

INTRODUCTORY PROBLEMS

These are different kinds of problem to those you are probably used to. They *do not* have just one right answer and there are many useful ways to tackle each of them. Your teacher is interested in seeing how well you can tackle these problems *on your own*. The methods you use are as important as the answers you get, so please *write down everything* you do, even if you are not sure it is right.

1 Target

On a calculator you are **only** allowed to use the keys

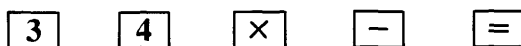

You can press them as often as you like.

You are asked to find a sequence of key presses that produce a given number in the display. For example, 6 can be produced by

$$3 \times 4 - 3 - 3 =$$

- Find a way of producing each of the numbers from 1 to 10. You must “clear” your calculator before each new sequence.
- Find a second way of producing the number 10. Give reasons why one way might be preferred to the other.

2 Discs

7

10

Here are two circular cardboard discs. A number is written on the top of each disc. There is another number written on the reverse side of each disc.

By tossing the two discs in the air and then adding together the numbers which land uppermost, I can produce any one of the following four totals:

11, 12, 16, 17.

- Work out what numbers are written on the reverse side of each disc.
- Try to find a different solution to this problem.

3 Leagues

A top division has 22 teams. Each team plays all the other teams twice—once at home, and once away. Games are usually played on Saturdays, but sometimes on Wednesdays too. The season lasts about 35 weeks.

There is a proposal to expand this top division to 30 teams.

How many matches in all would be played, and how many matches would each team play? What would the effect be on the length of the playing season?

A1 ORGANISING PROBLEMS

The Tournament

A tournament is being arranged. 22 teams have entered. The competition will be on a league basis, where every team will play all the other teams twice—once at home and once away. The organiser wants to know how many matches will be involved.

Often problems like this are too hard to solve immediately. If you get stuck with a problem, it often helps if you first try some simple cases.

So, suppose we have only 4 teams instead of 22.

Next, if you can find a helpful diagram, (table, chart or similar), it will help you to organise the information systematically.

For example,

Avoid this

A v B
B v A
C v A
A v D
C v D
C v B
C v B
A v D
~~C v A~~
~~C v D~~
D v A
D v C
C v B

Be organised like this

A v B A v C A v D
B v A B v C B v D
C v A C v B C v D
D v A D v B D v C

or, better still, like this

		AWAY TEAM			
		A	B	C	D
HOME TEAM	A		A v B	A v C	A v D
	B	B v A		B v C	B v D
	C	C v A	C v B		C v D
	D	D v A	D v B	D v C	

1

2

By now, you should be able to see that our 4 teams require 12 matches.

- * How many matches will 6 teams require?
How many matches will 7 teams require?
Invent and do more questions like these.

- * **Make a table** of your results. This is another key strategy . . .

Number of Teams	4	6	7			
Number of Matches	12					

- * Try to **spot patterns** in your table.

Write down what they are.

(If you can't do this, check through your working, reorganise your information, or produce more examples.)

- * Now try to **use your patterns** to solve the original problem with 22 teams.

- * Try to **find a general rule** which tells you the number of matches needed for *any* number of teams. Write down your rule in words and, if you can, by a formula.

- * **Check** that your rule always works.

- * **Explain** why your rule works.

Now use the key strategies . . .

Try some simple cases

Find a helpful diagram

Organise systematically

Make a table

Spot patterns

Use the patterns

Find a general rule

Explain why it works

Check regularly

to solve the problems on the next page . . .

3

Mystic Rose

This diagram has been made by connecting all 18 points on the circle to each other with straight lines. Every point is connected to every other point . . .

How many straight lines are there?

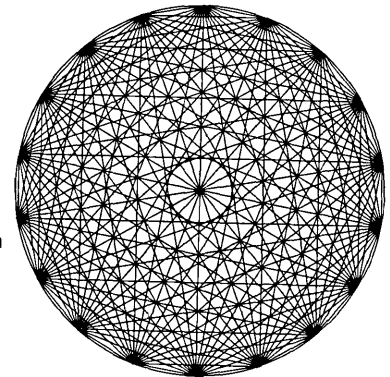

Money

Suppose you have the following 7 coins in your pocket . . .

1p, 2p, 5p, 10p, 20p, 50p, £1

How many different sums of money can you make?

4

A1 ORGANISING PROBLEMS

The aim of this booklet is to introduce pupils to specific strategic skills which are often helpful when attacking unfamiliar problems.

Approximately one hour will be needed. You may find that progress is slower than you expect, particularly if your timetable is based on shorter lessons. It is important that pupils are given time to “get to grips” with the problems, but are not allowed to spend a long time without making progress in a way that would also seriously delay the schedule.

Suggested Presentation

- 1 In order to involve the class, describe the problem of the “tournament” orally and, if possible, relate it to a tournament with which the pupils are themselves familiar.
- 2 Now either issue the booklet and ask the pupils to work through it individually or in pairs, or, alternatively, ask the class to describe how they would set about solving the problem, and follow up a few of their suggestions before starting the booklet.
- 3 Invite the pupils to tackle *at least one* of the 2 problems at the end of the worksheet. The “Mystic Rose” generates a quadratic sequence closely related to the “Tournament” sequence while the “Money” situation generates an exponential sequence. This is a more difficult problem, and is studied in further detail in A2: do not allow children to struggle with it too long before moving on to A2.

Note that in the “Mystic Rose” problem, the number of lines does not depend on the equal spacing of points around the circle, (although the symmetry of the pattern does).

- 4 While the pupils work, try to help by giving *strategic* hints and encouragement rather than by leading them through the problem with specific, detailed instructions. For example, “Have you tried a simpler case? How can you make it simpler?” is much better than “Try using 2, 3, then 4 points round the circle”. (Only give more detailed help if strategic hints *repeatedly* fail). Examples of strategic hints are given inside the back cover of this module. Pupils will need much encouragement in these early stages, until they can make these strategies part of their own toolkit. When arithmetic slips occur, point out their mistake. Technical skills like these are not our major centre of concern. When pupils are following a line of reasoning that is unfamiliar to you, or apparently unfruitful, allow them to pursue it and see what happens. They may surprise you!
- 5 Towards the end of each problem, encourage the pupils to generalise their results in words. Expressing a pattern as an algebraic formula is a very difficult mathematical activity. Pupils may be greatly helped towards it if they are encouraged to write down and explain their rules in words, as an intermediate step, rather than to attempt to translate the patterns directly into algebra. It is easy to underestimate just how difficult this is.

Below we give some examples.

I can spot a pattern in my table. If you square the top number, then you take the top number away from the result, which gives you the bottom number in the table. So $4^2 - 4 = 16 - 4 = 12$. (which is correct).

The pattern I notice is that the number multiplied by itself and then minus itself = the bottom number.

This is because if you make a square of the no. of teams and then cross

eg. 3 teams =

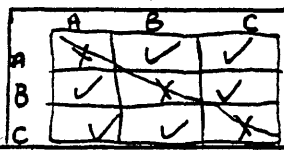

out the 'leading diagonal' which represents the matches played between similar teams, the no. of matches which you have to cross out will equal the no. of teams that there are.

$$22 \times 22 = 484 \quad 484 - 22 = 462 \quad x \times x - x = y$$

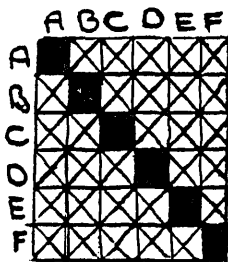

6 teams need to play 30 matches
 7 " " " " 42 "
 8 " " " " 56 "

Instead of drawing the box you could use a formula $6 - 1 = 5$ $6 \times 5 = 30$
 So $T - 1 = X$, $T \times X = M$
 $= T(T - 1)$

$$\begin{aligned} & \cdot 22 (22 - 1) \\ & = 22 (21) \\ & = \underline{\underline{462 \text{ matches}}} \end{aligned}$$

The rule is so because although all the teams play each other home and away, they don't play themselves and so for each team playing you have to subtract 1 match as they can't play themselves.

e.g. 7 teams playing

$$7 \times 7 = 49 \text{ matches}$$

$$7 \text{ teams can't play themselves so } 49 - 7 = 42 = 42 \text{ matches.}$$

- 6 Emphasise the importance of *checking* that the rule works in *every* case. Take the opportunity to show that a variety of rules work and can be developed into equivalent algebraic expressions.
- 7 A suitable conclusion to the lesson may be to discuss how useful the pupils found the strategies, and also if they have discovered any new ones which could be added to the list. For example, the pupil below has discovered the strategy of generating further cases from simpler cases rather than by starting afresh each time:

		Away Team						
		A	B	C	D	E	F	G
Home Team	A		AvB	AvC	AvD	AvE	AvF	AvG
	B	BvA		BvC	BvD	BvE	BvF	BvG
	C	CvA	CvB		CvD	CvE	CvF	CvG
	D	DvA	DvB	DvC		DvE	DvF	DvG
	E	EvA	EvB	EvC	EvD		EvF	EvG
	F	FvA	FvB	FvC	FvD	FvE		FvG
	G	GvA	GvB	GvC	GvD	GvE	GvF	

Four teams would require 12 matches
 Five teams would require 20 matches
 Six teams would require 30 matches
 Seven teams would require 42 matches

Number of teams.	2	3	4	5	6	7	A
Number of matches.	2	6	12	20	30	42	B

Note

- * Some notes are given on marking classwork in the Support Materials on page 162.
- * Do not go through the answers to the "Money" problem as this will be developed further in the next lesson.
- * It is helpful if pupils are re-issued with the booklet at the beginning of the next lesson.

A2 TRYING DIFFERENT APPROACHES

In the last lesson, you looked at the following problem . . .

Money

Suppose you have the following 7 coins in your pocket . . .

1p, 2p, 5p, 10p, 20p, 50p, £1.

How many different sums of money can you make?

We will now look at different ways of solving this problem and compare their advantages and disadvantages.

Method 1 "Method of 'differences' "

* Continue the table below for a few more terms:

Number of coins used	1	2	3	
Number of sums that can be made	1	3	7	

$\underbrace{\quad\quad\quad}_{2 \quad 4}$

- * Explain where the numbers 1, 3 and 7 in the table come from.
(Do these numbers depend on the particular coins that are chosen?)
- * Try to see a pattern in the differences between successive numbers in the table.
How will this pattern continue?
Are you sure? Try to explain it.
- * Solve the problem with the 7 coins using this method.

1

Method 2 "Systematic Counting"

							sum made
						①	1p
						②	2p
						② ①	3p
						⑤	5p
						⑤ ①	6p
						⑤ ②	7p
						⑤ ② ①	8p
						⑩	10p
						⑩ ①	11p
						⑩ ②	12p
						⑩ ② ①	13p
						⑩ ⑤	15p
						⑩ ⑤ ①	16p
						⑩ ⑤ ②	17p
						⑩ ⑤ ② ①	18p
						②⑩	20p
						②⑩ ①	21p

①	⑤	②⑩	⑩	⑤		①	£1.86
①	⑤	②⑩	⑩	⑤	②		£1.87
①	⑤	②⑩	⑩	⑤	②	①	£1.88

2

This diagram shows a systematic attempt to list all the possible sums of money that can be made. (There is insufficient room to reproduce it all!)

- * Try to see a quick way of counting the number of different sums.
- * Solve the problem with 7 coins using this method.

Method 3 "Finding a Rule"

- * Try to find a rule which links the number of coins with the number of sums of money directly.

Number of coins used	Rule ?	Number of sums that can be made
1	?	1
2	?	3
3	?	7
4	?	...
7	?	...

- * Try to express your rule in words. Check that your rule always works.
If you can, express your rule as a formula.
- * Solve the problem for 7 coins using your rule.

3

Method 4 "Drawing a Graph"

- * Draw a graph to show the relationship between the number of coins and the number of sums that can be made.

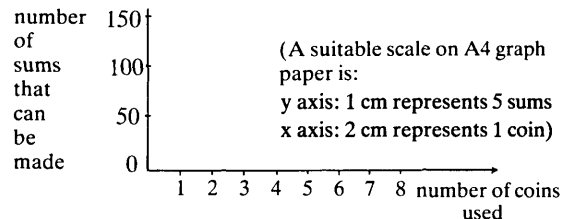

- * Try to use your graph to solve the problem for 7 coins.
- * What are the advantages and disadvantages of these 4 methods?
- * Can you invent any other methods?

Try to solve the following problem using four different methods.

Which method do you prefer for this problem? Why?

Town Hall Tiles

This pattern is made up of black and white tiles. It is 7 tiles across.

In the Town Hall there is a pattern like this which is 149 tiles across.

How many tiles will it contain altogether?

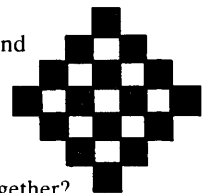

4

A2 TRYING DIFFERENT APPROACHES

Many pupils appear to think that there is only *one* correct method for approaching a particular problem. We aim to show here that this is rarely the case, although some methods do have advantages over others.

Approximately one hour will be needed.

Suggested Presentation

- 1 Ask the pupils to recap what they learnt during the first lesson. The first booklet, A1, should be reissued to facilitate this.
- 2 Now issue booklet A2. Remind the pupils of the money problem from sheet A1 and ask the class to work through each of the 4 methods shown, and to discuss and write down the advantages and disadvantages of each method.
Alternatively, divide the class into groups of about four pupils and encourage each group to allocate one method to each of its members. They can then present and discuss their views on this method to their group.
- 3 Discuss the advantages and disadvantages of each of the 4 methods with the class. A list may be drawn up on the blackboard.

For example:

<u>Method</u>	<u>Advantages</u>	<u>Disadvantages</u>
"Systematic Counting"	Everyone can count!	Takes a long time, unless you find an efficient way
"Differences"	Easy to spot patterns.	You have to work through every case in order to answer the problem for 7 coins.
"Finding a Rule"	Once a rule is found, it is very easy to solve the problem with <u>any</u> number of coins.	Quite hard to guess a rule.
"Drawing a Graph"	It shows the nature of the relationship quite clearly.	Takes a long time. Can only extrapolate the graph accurately when the sequence is linear - so in this case it's useless.

It should be pointed out that these methods have only been compared on one problem and the list of advantages and disadvantages may change when different problems are considered. Calculators and computers increase the usefulness of inductive techniques like the "method of differences" and logarithmic or other kinds of graph paper can give considerable power to graphical methods. However, though important, such discussions are beyond the scope of this present text.

- 4 Ask the pupils (or groups) to look at the "Town Hall Tiles" problem and attempt to solve it using a variety of methods.

The two pupils below have achieved considerable success at pattern spotting and generalising with this problem.

7 tiles across

$$\begin{aligned} \text{white tiles} &= 3^2 = 9 + 16 = 25 \text{ tiles altogether.} \\ \text{black tiles} &= 4^2 \\ &\quad (3+4=7) \end{aligned}$$

9 tiles across.

$$\begin{aligned} \text{white tiles} &= 4^2 = 16 + 25 = 41 \text{ tiles altogether.} \\ \text{black tiles} &= 5^2 \\ &\quad (4+5=9) \end{aligned}$$

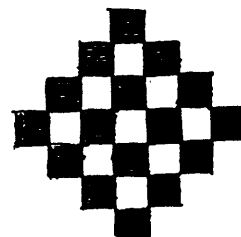

11 tiles across.

$$\begin{aligned} \text{white tiles} &= 5^2 = 25 + 36 = 61 \text{ tiles altogether.} \\ \text{black tiles} &= 6^2 \\ &\quad (5+6=11) \end{aligned}$$

∴

149 tiles across

$$\begin{aligned} \text{white tiles} &= 74^2 = 5476 + 5625 = 11,101 \text{ tiles} \\ \text{black tiles} &= 75^2 \\ &\quad (74+75=149) \end{aligned} \text{ altogether.}$$

Take the number of squares along across Add 1
 Then Divide that number by 2 to give the number
 of black squares across Square this number to give
 the total number of black squares. Subtract 1 from
 the number of black squares across to give the number
 of white squares and square that number. Add this
 to the total number of black squares and you have
 the answer

x = number of tiles across.

$$\left(\frac{x+1}{2}\right)^2 + \left(\frac{x-1}{2}\right)^2 = \text{TOTAL}$$

$$(x+1)(x+1) \quad (x-1)(x-1)$$

$$\frac{x^2 + 2x + 1}{2^2} + \frac{x^2 - 2x + 1}{2^2}$$

$$= \frac{x^2 + 2x + 1 + x^2 - 2x + 1}{4}$$

$$= \frac{2x^2 + 2}{4}$$

$$= \frac{x^2 + 1}{2}$$

A3 SOLVING A WHOLE PROBLEM

Try to solve the following problem using all you have learnt. A list of strategic hints is provided over the page.

Flower Beds

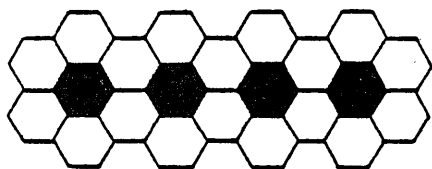

The council wish to create 100 flower beds and surround them with hexagonal paving slabs according to the pattern shown above. (In this pattern 18 slabs surround 4 flower beds.) How many slabs will the council need? Find a formula that the council can use to decide the number of slabs needed for any number of flower beds.

1

- * Try some simple cases.
- * Organise them systematically using a helpful diagram or other representation.
- * Try other simple cases and make a table of your results.
- * Look for patterns in your table. Write them down in words.
- * Use these patterns to find a general rule. Try to write your rule down in words. If you can, express your rule as an algebraic formula. Check that your rule always works.
- * Try to explain why your rule works.
- * Use your rule to find out how many paving slabs will be needed for 100 flower beds.
- * Use your rule to write down the number of paving slabs needed for n flower beds. (There are several ways of doing this. Try to find some alternatives.)
- * If you get stuck—try a different approach.

2

Now try this problem in a similar way:

House of Cards

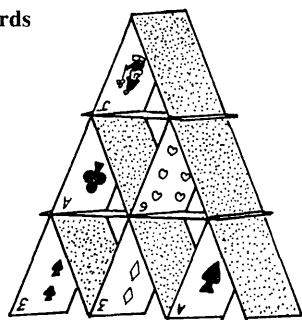

This house of cards is 3 storeys high. 15 cards are needed.

- * How many cards would be needed for a similar house, 10 storeys high?
- * The world record for the greatest number of storeys is 61. How many cards would you need to break this record, and make a house 62 storeys high?

3

INVENTING A PROBLEM

Flower Beds

There are many other ways of surrounding flower beds with hexagonal paving slabs. Invent your own examples and try to find formulae.

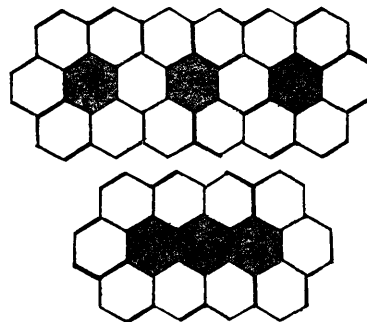

House of Cards

Try to think of other ways of constructing houses of cards. Draw them. How many cards would you need in order to break the world record using your system?

4

A3 SOLVING A WHOLE PROBLEM

This booklet aims to give pupils an opportunity to use the strategies developed so far on two complete tasks. Considerable guidance on which strategies to use is provided, especially for the first problem.

Approximately one hour will be needed.

Suggested Presentation

- 1 Issue booklet A3 and suggest they look at “Flower Beds”, a linear situation, first. *Allow the pupils plenty of time* to struggle with the problem themselves.
- 2 Tour the room while the pupils are working, and try to help them by providing encouragement and *strategic* hints, rather than by leading them through with specific detailed instructions. (Examples of strategic hints are given on the inside of the back cover).

Emphasise that the hints in the booklet are not intended to be a list of questions, but are there to help only if pupils get stuck. Some pupils may be able to solve the problem without referring to any of them. After “Flower Beds” encourage the pupils to move on to the “House of Cards” problem. This is a much harder problem, which generates a quadratic sequence, but the same strategies will provide a pay-off. (These problems are not unlike questions that may occur in the exam, but differ in the amount of strategic support given. From now on, pupils should therefore be encouraged to manage without the hints as far as possible).
- 3 The final section, “Inventing a Problem”, invites pupils to construct their own situation. This is an important new activity which requires both imagination and confidence.
- 4 Finally, conclude the lesson by drawing their attention to the list of strategies in A1. Ask pupils to supplement this list with any strategies that they have personally found useful.

SOME SOLUTIONS

The Tournament

A tournament is being arranged. 22 teams have entered. The competition will be on a league basis, where every team will play all the other teams twice—once at home and once away. The organiser wants to know how many matches will be involved.

Try some simple cases . . . Find a helpful diagram . . . Organise systematically

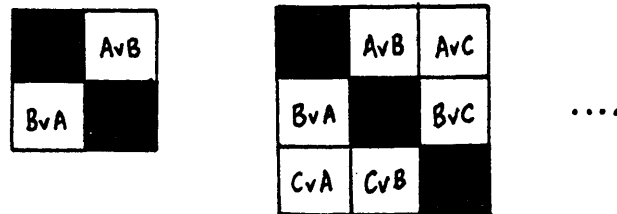

Make a table

Number of teams	1	2	3	4	5	6	7	...	22
Number of matches	0	2	6	12	20	30	42	...	?

Spot patterns

In the “differences”

$$0 \quad \overset{+2}{\curvearrowright} \quad 2 \quad \overset{+4}{\curvearrowright} \quad 6 \quad \overset{+6}{\curvearrowright} \quad 12 \quad \overset{+8}{\curvearrowright} \quad 20 \quad \overset{+10}{\curvearrowright} \quad 30 \quad \dots$$

In the relationship between the number of teams and number of matches . . .

Number of teams	1	2	3	4	5	6	7	22
	↓	↓	↓	↓	↓	↓	↓	↓
	×0	×1	×2	×3	×4	×5	×6	×21
Number of matches	0	2	6	12	20	30	42	...

Use the patterns . . . Find a general rule . . .

The general formula is $m=n(n-1)$ where m =number of matches
 n =number of teams.

The solution to the original problem ($n=22$) is therefore 462 matches.

Explanation

There are many different ways of arriving at a general formula using the geometry of the situation. For example:

- * There are two triangular halves to the fixture table. Each half has $1+2+3+\dots+(n-1)$ matches. So altogether there are $2(1+2+3+\dots+(n-1))$ matches.
- * Each row of the fixture table has $(n-1)$ matches. There are n teams, so altogether there are $n(n-1)$ matches.
- * The whole grid contains n^2 “squares”. The diagonal contains n squares. Therefore n^2-n matches must be played.

Notice how the identity for summing triangular numbers arises quite naturally:

$$1+2+3+\dots+(n-1)=\frac{1}{2}n(n-1)$$
$$\text{or } 1+2+\dots+n=\frac{1}{2}n(n+1)$$

SOME SOLUTIONS

Mystic Rose
 This diagram has been made by connecting all 18 points on the circle to each other with straight lines. Every point is connected to every other point . . .
 How many straight lines are there?

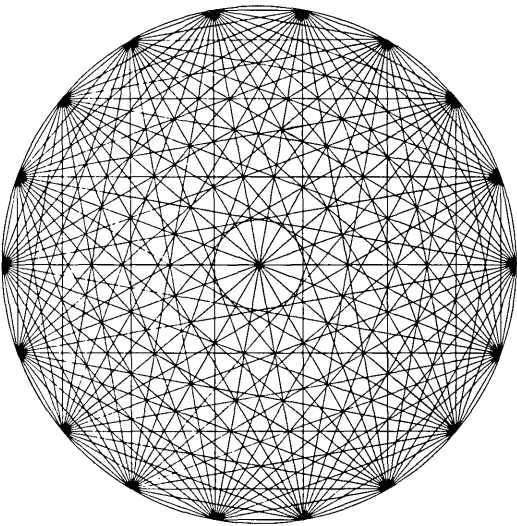

Try some simple cases . . . Find a helpful diagram . . . Organise systematically

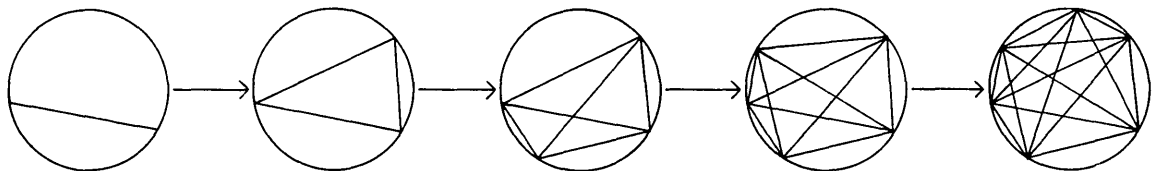

(Notice that there is no need to space the points around the circle in a regular way. In fact the reasons for the difference patterns shown below become much clearer if fresh points are added to the same diagram).

Make a table

Number of points	2	3	4	5	6	. . .	18
Number of lines	1	3	6	10	15	. . .	?

(Note: this table shows “triangle” numbers. Compare this with the “Tournament” sequence).

Spot patterns

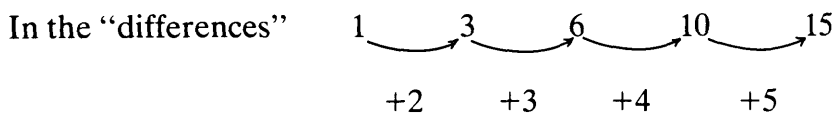

(Explanation: Each new point must be joined to all the previous points, which increase by one each time).

Spot patterns

In the relationship between the number of points and number of lines

number of points		number of lines
2	$\times \frac{1}{2}$	1
3	$\times 1$	3
4	$\times 1\frac{1}{2}$	6
5	$\times 2$	10
6	$\times 2\frac{1}{2}$	15

Use the patterns . . . Find a general rule

The general formula is $l = \frac{1}{2}p(p-1)$ where l = number of lines
 p = number of points

The solution to the original problem ($p=18$) is therefore 153 lines.

Explanation

Each point is connected to $p-1$ other points. So there are $p(p-1)$ connections. But since each line has been counted twice, the total number of lines must be $\frac{1}{2}p(p-1)$.

Notice the close relationship between this problem and the "Tournament" problem. If one imagines the teams A, B, C, . . . as the points around the circle, and a match as the line joining them, then it is easily seen that the "Tournament" sequence must be twice the "Mystic Rose" sequence as each match is played twice.

SOME SOLUTIONS

Money

Suppose you have the following 7 coins in your pocket . . .

1p, 2p, 5p, 10p, 20p, 50p, £1

How many different sums of money can you make?

Try some simple cases

Suppose we have 2 coins (1p, 2p), then we can make 3 sums of money: 1p, 2p, 3p.

With 3 coins (1p, 2p, 5p) we can make 7 sums of money: 1p, 2p, 3p, 5p, 6p, 7p, 8p.

Find a helpful diagram . . . Organise systematically . . . Make a table . . .

Coins used	Sums produced	Total
1p	1p	1
1p, 2p	1p, 2p (1 coin) 3p (2 coins)	2+1=3
1p, 2p, 5p	1p, 2p, 5p (1 coin) 3p, 6p, 7p (2 coins) 8p (3 coins)	3+3+1=7
1p, 2p, 5p, 10p	1p, 2p, 5p, 10p (1 coin) 3p, 6p, 7p, 11p, 12p, 15p (2 coins) 8p, 13p, 16p, 17p (3 coins) 18p (4 coins)	4+6+4+1=15

Another method is illustrated in booklet A2.

Spot patterns

In the differences: 1 $\xrightarrow{+2}$ 3 $\xrightarrow{+4}$ 7 $\xrightarrow{+8}$ 15 $\xrightarrow{+16}$ 31 . . .

Or perhaps in the table:

number of coins used	number of sums produced
1	$1=2-1$
2	$3=2\times 2-1$
3	$7=2\times 2\times 2-1$
4	$15=2\times 2\times 2\times 2-1$
...	...

Use the patterns . . . Find a general rule

The general formula is $s=2^n-1$ where s =number of sums
 n =number of coins used

The solution for 7 coins is therefore $2^7-1=127$ different sums.

Explanation

Each coin is either considered or it is not, giving the following kind of tree diagram:

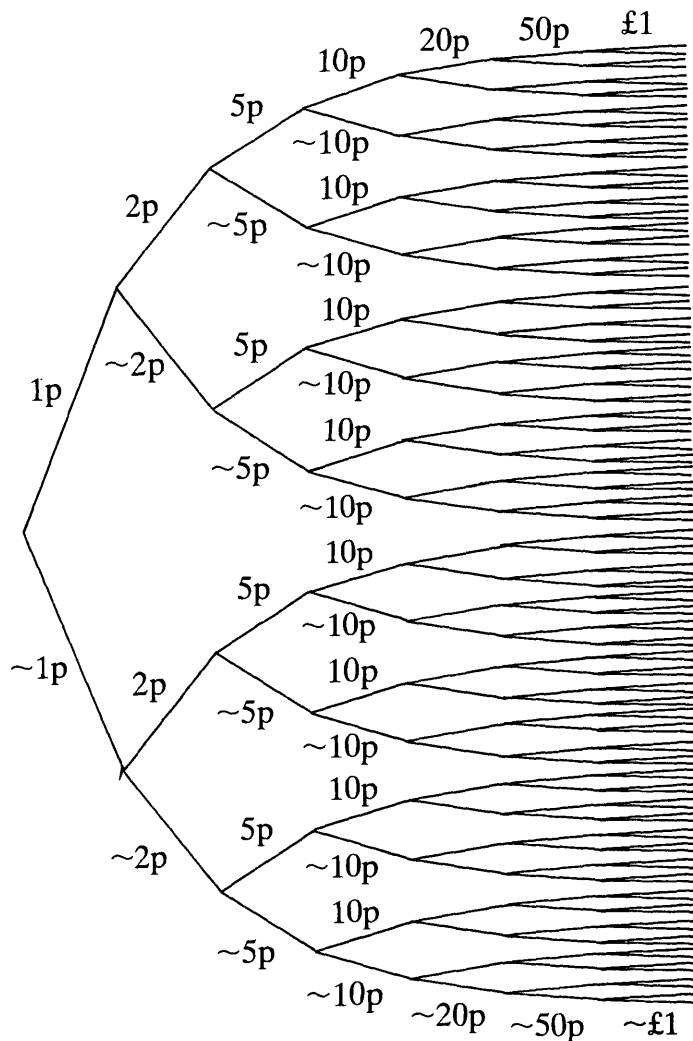

This will give $2^7=128$ possible sums, but of course we must omit the case where no coins at all are used.

SOME SOLUTIONS

Town Hall Tiles

This pattern is made up of black and white tiles. It is 7 tiles across.

In the Town Hall there is a pattern like this which is 149 tiles across.

How many tiles will it contain altogether?

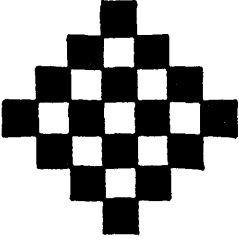

Try some simple cases . . Find a helpful diagram . . Organise systematically

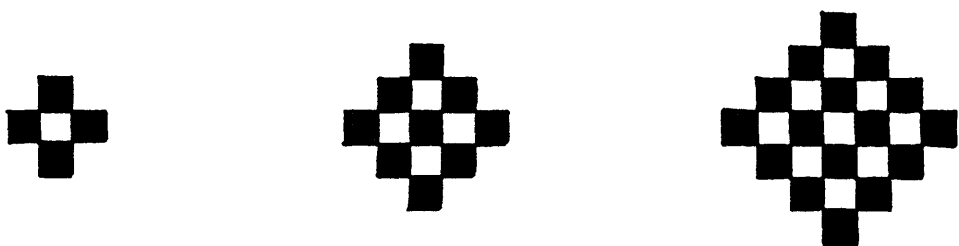

Make a table

“length of pattern”	1	3	5	7	...	149
number of tiles needed	1	5	13	25	...	?

Spot patterns

In the differences: 1 5 13 25 41 ...

$\xrightarrow{+4}$ $\xrightarrow{+8}$ $\xrightarrow{+12}$ $\xrightarrow{+16}$

In the relationship between the length of pattern and the number of tiles needed:

length of pattern		no. of tiles needed
1	$\times 1 - 0 \rightarrow$	1
3	$\times 2 - 1 \rightarrow$	5
5	$\times 3 - 2 \rightarrow$	13
7	$\times 4 - 3 \rightarrow$	25

This pattern leads to the formula $t = \frac{1}{2}n(n+1) - \frac{1}{2}(n-1) = \frac{1}{2}(n^2+1)$

Use the patterns . . . Find a general rule

The general formula is $t = \frac{1}{2}(n^2 + 1)$ where $n = \text{length of pattern}$
 $t = \text{number of tiles needed}$

So for $n = 149$, the number of tiles needed = 11101

Explanation

There are many ways of discovering the formula $t = \frac{1}{2}(n^2 + 1)$ from the geometry of the situation. Here are just two examples:

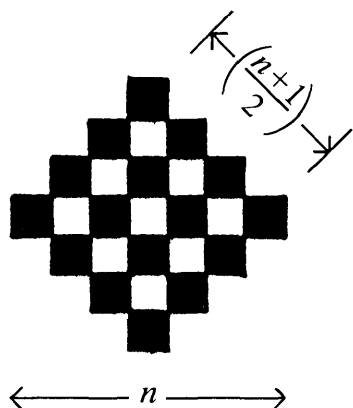

For a pattern n tiles across,
 there are $\left(\frac{n+1}{2}\right)^2$ black tiles and

$\left(\frac{n-1}{2}\right)^2$ white tiles.

So altogether there are

$$\left(\frac{n+1}{2}\right)^2 + \left(\frac{n-1}{2}\right)^2 = \frac{1}{2}(n^2 + 1) \text{ tiles}$$

or alternatively:

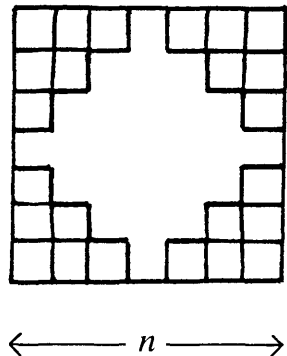

There are n^2 tiles altogether in the square.
 We must now subtract 4 triangle numbers to reach our required total.

So altogether we need

$$\begin{aligned} & n^2 - 4 \left(1 + 2 + \dots + \left(\frac{n-1}{2}\right) \right) \\ &= n^2 - 4 \left(\frac{1}{2} \left(\frac{n-1}{2}\right) \left(\frac{n+1}{2}\right) \right) \\ &= n^2 - \frac{1}{2}(n^2 - 1) \\ &= \frac{1}{2}(n^2 + 1) \text{ tiles.} \end{aligned}$$

SOME SOLUTIONS

Flower Beds

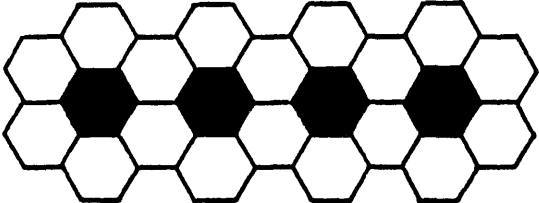

The council wish to create 100 flower beds and surround them with hexagonal paving slabs according to the pattern shown above. (In this pattern 18 slabs surround 4 flower beds).

How many slabs will the council need?

Find a formula that the council can use to decide the number of slabs needed for any number of flower beds.

Try some simple cases . . . Find a helpful diagram . . . Organise systematically

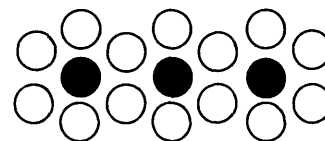
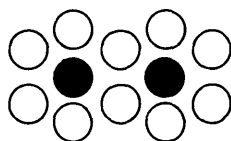
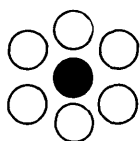

(It takes a long time to draw hexagons, so we have used black and white circles as a helpful representation.)

Make a table

Number of flower beds	1	2	3	4	5	...	100
Number of paving slabs	6	10	14	18	22	...	?

Spot patterns

In the differences: 6 → 10 → 14 → 18 → 22

+4 +4 +4 +4

In the relationship between the number of beds and the number of slabs:

flower beds		paving slabs
1	$\xrightarrow{\times 3+3}$	6
2	$\xrightarrow{\times 3+4}$	10
3	$\xrightarrow{\times 3+5}$	14
4	$\xrightarrow{\times 3+6}$	18
5	$\xrightarrow{\times 3+7}$	22

This is just one example of many possibilities which generate a pattern. In this case

$$f \times 3 + (f+2) = p$$

Use the pattern . . . Find a general rule

The general formula is $p=4f+2$ or $p=2(2f+1)$ where f =number of flower beds
 p =number of paving slabs

The solution for the original problem is therefore:

402 paving slabs will be needed in order to surround 100 beds.

Explanation

The flower beds may be counted in several different ways. For example:

Method	Diagram	Generalisation
Each time a flower bed is added 4 more paving slabs are needed. 2 are needed to start with.	<p style="text-align: center;">2 + 4 + 4 + 4</p>	$2+4f=p$
Each flower bed is surrounded by 6 slabs. However, if we just multiply the number of beds by 6 we count some slabs twice (×). (There are $f-1$ pairs of these)		$6f-2(f-1)=p$

It is valuable to show that these and other expressions are really equivalent.

SOME SOLUTIONS

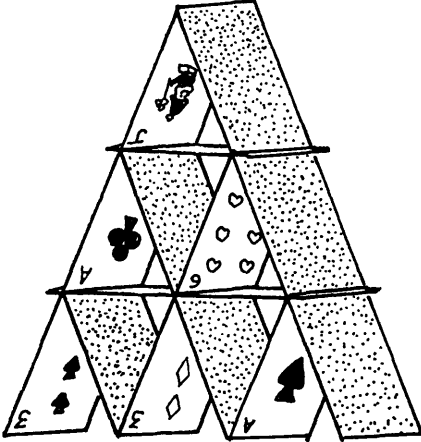

House of Cards



This house of cards is 3 storeys high.
15 cards are needed.

- * How many cards would be needed for a similar house, 10 storeys high?
- * The world record for the greatest number of storeys is 61. How many cards would you need to break this record, and make a house 62 storeys high?

Try simple cases . . . Find a helpful diagram . . . Organise systematically . . .

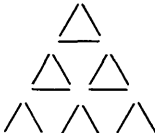
			
1 storey	2 storeys	3 storeys

Make a table

Number of storeys	1	2	3	4	5	6	. . .	10	61
Number of cards needed	2	7	15	26	40	57	. . .	?	?

Look for a Pattern . . .

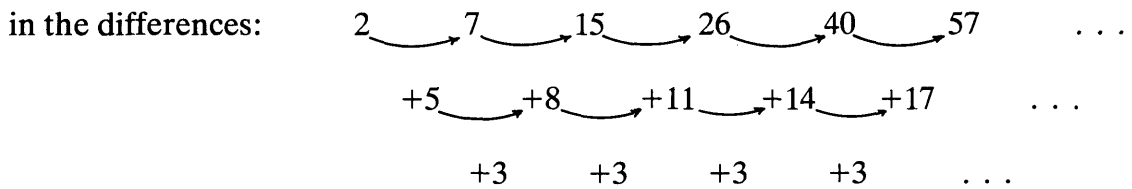

or in a table showing the direct relationship between the number of storeys and the number of cards.

Finding a pattern in this table is quite difficult:

Number of storeys		Number of cards
1	$\xrightarrow{\times 2 + 0}$	2
2	$\xrightarrow{\times 3 + 1}$	7
3	$\xrightarrow{\times 4 + 3}$	15
4	$\xrightarrow{\times 5 + 6}$	26
5	$\xrightarrow{\times 6 + 10}$	40
6	$\xrightarrow{\times 7 + 15}$	57

The 0, 1, 3, 6, 10, 15 . . . sequence is like that in the “Mystic Rose” or half that in the “Tournament” problem. This leads to the formula $n \times (n+1) + \frac{1}{2}n(n-1) = c$ or $c = n(n+1) + \frac{1}{2}n(n-1)$

We would not expect many pupils to find such a pattern.

Use the patterns . . . Find a general rule

The general rule is $c = \frac{n(3n+1)}{2}$ where c = the number of cards needed
 n = the number of storeys

So for a house of cards 10 storeys high, we would need 155 cards.
 So for a house of cards 62 storeys high, we would need 5797 cards.

Explanation

The geometry of the situation shows quite clearly that the sequence is related to “triangle” numbers:

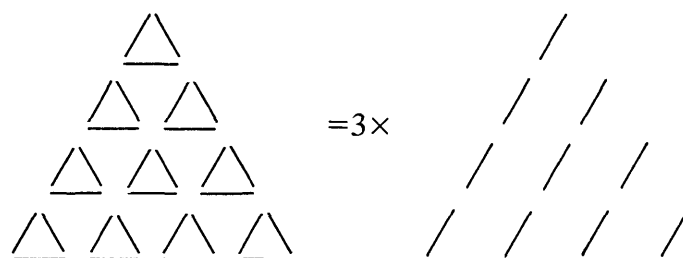

All that is needed is for the bottom layer of cards to be removed.

Thus, for n storeys, the number of cards needed $= 3 \times \left[\frac{n(n+1)}{2} \right] - n = \frac{n(3n+1)}{2}$.

(The formula $\frac{n(n+1)}{2}$ can be derived from those met in the “Mystic Rose” and “Tournament” problems).

Unit B

CONTENTS

Introduction		71
<hr/>		
B1 Pond Borders	The problem	72
	Pupil's checklist	73
	Teaching notes	74
	Solutions	75
<hr/>		
B2 The "First to 100" game	The game	76
	Pupil's checklist	77
	Teaching notes	78
	Solutions	79
<hr/>		
B3 Sorting	The problem	80
	Pupil's checklist	81
	Teaching notes	82
	Solutions	85
<hr/>		
B4 Paper Folding	The problem	88
	Pupil's checklist	89
	Teaching notes	90
	Solutions	91

INTRODUCTION

This Unit gives the pupils a good deal less guidance as they work through problems that succumb to fairly similar strategies to those introduced in Unit A. Here “pupil checklists” are provided, which the teacher may like to give out, either when pupils are stuck or later as a stimulus for discussion on how they tackled the problems. The teacher may also use the checklist as a source of oral hints to be provided to pupils who are in difficulty.

POND BORDERS

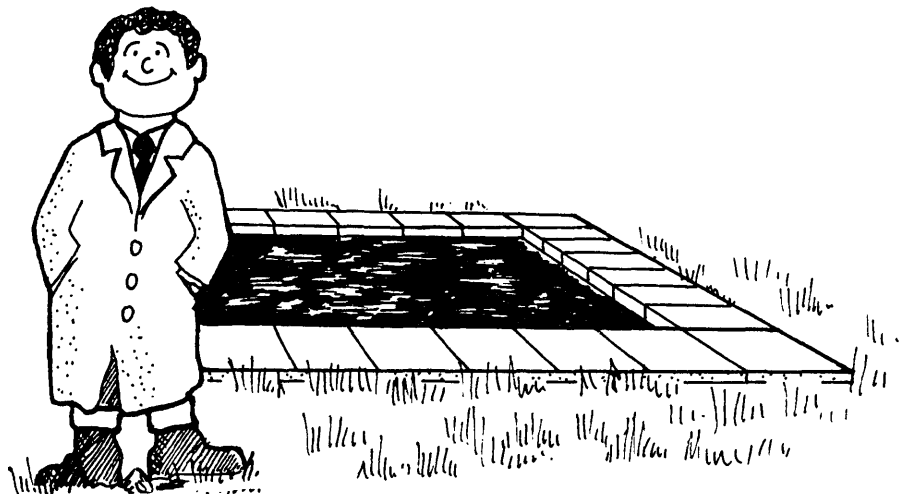

Joe works in a garden centre that sells square ponds and paving slabs to surround them. The paving slabs used are all 1 foot square.

The customers tell Joe the dimensions of the pond, and Joe has to work out how many paving slabs they need.

- * How many slabs are needed in order to surround a pond 115 feet by 115 feet?
- * Find a rule that Joe can use to work out the correct number of slabs for any square pond.
- * Suppose the garden centre now decides to stock rectangular ponds. Try to find a rule now.
- * Some customers want Joe to supply slabs to surround irregular ponds like the one below:—

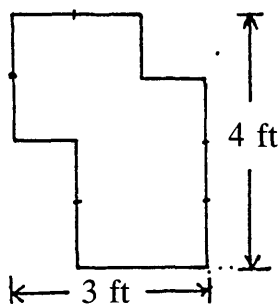

(This pond needs 18 slabs. Check that you agree).

Try to find a rule for finding the number of slabs needed when you are given the overall dimensions (in this case 3 feet by 4 feet).

Explain why your rule works.

POND BORDERS . . . PUPIL'S CHECKLIST

Try some simple cases * Try finding the number of slabs needed for some small ponds.

Be systematic * Don't just try ponds at random!

Make a table * This should show the number of slabs needed for different ponds. (It may need to be a two-way table for rectangular and irregular ponds).

Spot patterns * Write down any patterns you find in your table. (Can you explain *why* they occur?)
* Use these patterns to extend the table.
* Check that you were right.

Find a rule * Either use your patterns, or look at a picture of the situation to find a rule that applies to any size pond.

Check your rule * Test your rule on small and large ponds.
* Explain *why* your rule always works.

B1 POND BORDERS

This situation provides the pupils with an opportunity to use the strategies developed in Unit A to solve a problem which is linear in nature. They should be given less detailed guidance in order to develop their own problem solving powers.

Suggested Presentation

- 1 Explain to the pupils that, as far as possible, they should attempt to solve this problem without your help. Remind them of the strategies outlined in Unit A.
- 2 Allow them time to work at the problem in groups, in pairs or individually. Encourage them to write down their ideas and explanations as well as mere answers.
- 3 If pupils get really stuck, then let them struggle for a short while before issuing the "Pupil's Checklist". This provides a series of useful hints. If they are still unable to proceed then you may need to give more detailed help.
- 4 After everyone has reached some kind of result for the 115' × 115' pond, it is worth holding a class discussion to examine the different approaches that have been used. Collect several on the blackboard and discuss the rules (verbal or algebraic) that result from the patterns formed. Pupils may need help to discover the equivalence of various expressions. This should be done by substituting numbers, as well as by algebraic manipulation. We give just two typical examples below:—

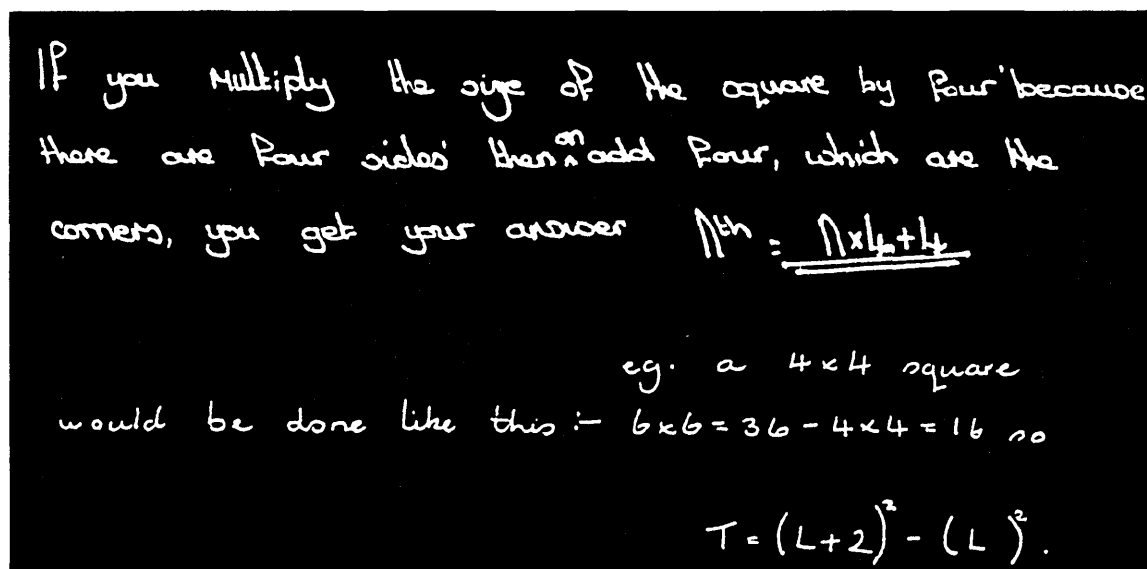

It is by no means obvious that these two methods are equivalent.

- 5 During the remainder of the lesson most pupils should progress on to rectangular and irregular ponds. Encourage them to try a variety of approaches. Even if they have used the checklist for the first question, encourage them to do without it for the remainder of the lesson.
- 6 Finally, pupils should be given an opportunity to write a report which explains their methods and discoveries.

SOLUTIONS TO “POND BORDERS”

* For square $n \times n$ ponds we obtain the following table:

Length of one side	n	1	2	3	4	5	...	
Number of slabs needed	s	8	12	16	20	24	...	

The number of slabs needed for a $115' \times 115'$ pond = 464 (= $4 \times 115 + 4$).

The rule for evaluating s from n can be written in many forms.

For example:

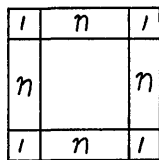

$$s = 4n + 4$$

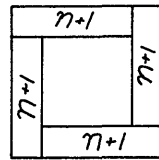

$$s = 4(n+1)$$

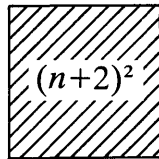

$$- \quad =$$

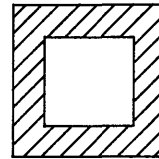

$$s = (n+2)^2 - n^2$$

Encourage discussion which enables pupils to see that these are all equivalent.

* For rectangular $m \times n$ ponds, the following table and corresponding formulae are obtained.

Number of slabs needed for $m \times n$ pond						
		width in feet 'n'				
		1	2	3	4	5
length in feet 'm'	1	8	10	12	14	16
	2	10	12	14	16	18
	3	12	14	16	18	20
	4	14	16	18	20	22
	5	16	18	20	22	24

$$s = 2(m+n+2)$$

or $s = 2m + 2n + 4$

or $s = 2(m+1) + 2(n+1)$

or $s = (m+2)(n+2) - mn$

etc.

* Irregular ponds with overall dimensions $m \times n$, also require $2(m+n+2)$ slabs, provided they are “convex”, in the sense that they contain no U shaped holes.

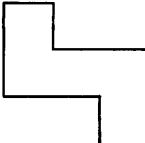
(E.g.  would not obey this formula, but  would).

It is interesting to try to devise formulae which work for shapes which contain U shaped holes.

THE “FIRST TO 100” GAME

This is a game for two players.

Players take turns to choose any whole number from 1 to 10.

They keep a running total of all the chosen numbers.

The first player to make this total reach exactly 100 wins.

Sample Game:

Player 1's choice	Player 2's choice	Running Total
10		10
	5	15
8		23
	8	31
2		33
	9	42
9		51
	9	60
8		68
	9	77
9		86
	10	96
4		100

So Player 1 wins!

Play the game a few times with your neighbour.

Can you find a winning strategy?

- * Try to modify the game in some way, e.g.:
 - suppose the first to 100 *loses* and overshooting is not allowed.
 - suppose you can only choose a number between 5 and 10.

THE “FIRST TO 100” GAME . . . PUPIL’S CHECKLIST

-
- | | |
|------------------------------|---|
| Try some simple cases | <ul style="list-style-type: none">* Simplify the game in some way:<ul style="list-style-type: none">e.g.:— play “First to 20”e.g.:— choose numbers from 1 to 5e.g.:— just play the end of a game. |
|------------------------------|---|
-
- | | |
|----------------------|---|
| Be systematic | <ul style="list-style-type: none">* Don’t just play randomly!* Are there good or bad choices? Why? |
|----------------------|---|
-
- | | |
|----------------------|---|
| Spot patterns | <ul style="list-style-type: none">* Are there <i>any</i> positions from which you can always win?* Are there <i>other</i> positions from which you can always reach these winning positions? |
|----------------------|---|
-
- | | |
|--------------------|--|
| Find a rule | <ul style="list-style-type: none">* Write down a description of “how to always win this game”. Explain why you are sure it works.* Extend your rule so that it applies to the “First to 100” version. |
|--------------------|--|
-
- | | |
|------------------------|--|
| Check your rule | <ul style="list-style-type: none">* Try to beat somebody who is playing according to your rule.* Can you convince <i>them</i> that it always works? |
|------------------------|--|
-
- | | |
|------------------------------------|---|
| Change the game in some way | <ul style="list-style-type: none">* Can you adapt your rule for playing a new game where:<ul style="list-style-type: none">— the first to 100 <i>loses</i>, (overshooting is not allowed)— you can only choose numbers between 5 and 10.— . . . |
|------------------------------------|---|
-

B2 THE "FIRST TO 100" GAME

This situation is very different to those we have already considered, and it may surprise some pupils to find that their strategies are useful when tackling problems which seem to be quite unrelated. We have chosen this particular game because it is very easy to play, it beautifully illustrates the power of inductive reasoning and there is a simple strategy for winning that is not at all obvious. The aim here is to encourage the pupils to think the situation out for themselves.

Suggested Presentation

- 1 Play a few games on the blackboard, or orally, with members of the class and clarify any misunderstandings about the rules.
- 2 Allow the pupils time to become involved in playing the game in pairs. Encourage them to keep a record of their games and after each one to reflect upon their own strategies:

(Joanne and Theresa, after playing 2 games)

Theresa: "When you get into the 80's you can find a way to win. It's got something to do with 85-90."

(They play another game, and Theresa is on 88)

Theresa: "Now if I choose one I can win . . . I think."

(They play another game)

Joanne: "Look, if you get to 89 you must win, 'cos you couldn't win even if you choose ten."

- 3 After 20 minutes or so invite pupils to begin to *analyse* the game. Offer the Checklist to pupils who do not know how to begin to do this. Allow plenty of time for this.
- 4 Hold a class discussion. Ask pupils to report on their discoveries, and list them on the blackboard:

whoever gets to 90 first
has lost.

Whoever starts first
and gets to 67 or 78
or 89 wins!

The way to
win this
game is to
get to 89
first.

- 5 Ask the pupils to write up all their findings, and explain their methods whenever possible.

There is a winning pattern in this game. If you start with a one then your opponent will add a number between one and ten. You then make the total up to 12. Then they add a number the total of which you make up to 23. Here is the pattern of winning numbers

1 12 23 34 45 56 67 78 89 100
(each time the difference is eleven)

If you carry on this pattern your opponent cannot win as they cannot add eleven to make the total up to one of the winning pattern numbers.

- 6 Finally, discuss possible extensions. Two possibilities are included on the worksheet, but there are many others.

e.g.:

“Suppose you can put any coin (say 2p’s, 5p’s and 10p’s only) on the table. Players take turns and the one who makes the total up to £1 wins.”

Producing a write-up of such a situation would make an excellent activity for homework.

SOLUTIONS TO THE “FIRST TO 100” GAME

- * If the first player chooses 1, then whatever the second player chooses, the first player can always reach the subtotals:

1, 12, 23, 34, 45, 56, 67, 78, 89, 100.

(Notice that these numbers are 11 apart, so the second player can never break out of this sequence).

- * When the first to 100 loses; then the second player can always win by reaching the subtotals:

11, 22, 33, 44, 55, 66, 77, 88, 99.

- * When only numbers between 5 and 10 can be chosen, then the first player can always win by reaching the subtotals:

10, 25, 40, 55, 70, 85, 100.

In general, when only numbers between a and b can be chosen, then winning subtotals are

$100, 100-(a+b), 100-2(a+b), 100-3(a+b) \dots$

SORTING

50 red and 50 blue counters are placed alternately in a line across the floor:
RBRBRBR . . . RB

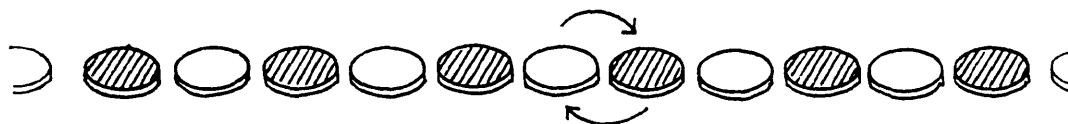

By swapping adjacent counters (see arrows) they have to be sorted into 2 groups, with all the reds at one end and all the blues at the other:
RRR . . . RRRBBB . . . BBB



- * What is the *least* number of moves needed to do this?
How many moves are needed for n red and n blue counters?

- * What happens when the counters are placed in different starting formations:
For example RRBBRRBBRRBB . . . RRBB
or RBBRRBBRRBB . . . RBBR

- * What happens when there are red, blue and green counters arranged
RBGRBG . . . RBG
What happens with 4 colours?
What happens with m colours?

- * Invent and explore your own arrangement of counters.
Write about your findings.

SORTING . . . PUPIL'S CHECKLIST

-
- | | |
|------------------------------|---|
| Try some simple cases | * Try finding the number of moves needed for just a few counters. |
|------------------------------|---|
-
- | | |
|----------------------|---|
| Be systematic | * Try swapping counters systematically. |
|----------------------|---|
-
- | | |
|--------------------------------------|---|
| Find a helpful representation | * If you are unable to use real counters, can you find a simple substitute?
* Can you use the simple cases you have already solved, to generate further cases by adding extra pairs of counters rather than starting from the beginning each time? |
|--------------------------------------|---|
-
- | | |
|---------------------|--|
| Make a table | * Make a table to show the relationship between the number of counters and the number of swaps needed. |
|---------------------|--|
-
- | | |
|----------------------|--|
| Spot patterns | * Write about any patterns you find in your table.
(Can you explain why they occur?)
* Use these patterns to extend the table.
* Check that you were right. |
|----------------------|--|
-
- | | |
|--------------------|---|
| Find a rule | * Use your patterns, or your representation, to find a rule that applies to any number of counters. |
|--------------------|---|
-
- | | |
|------------------------|---|
| Check your rule | * Test your rule on small and large numbers of counters.
* Try to explain <i>why</i> your rule must always work. |
|------------------------|---|
-

	R	B	R	B	R	B	R	B	R	B				
	R	R	B	B										
2	R	R	B	R	B									
3	R	R	R	B	B									
4	R	R	R	B	B	R	B	B						
5	R	R	R	B	R	B	B	B						
6	R	R	R	R	B	B	B	B						
7	R	R	R	R	B	B	B	R	B	B				
8	R	r	r	r	b	b	r	b	b	b				
9	r	r	r	r	b	r	b	b	b	b				
10	r	r	r	r	r	b	b	b	b	b				
12	r	r	r	r	r	b	b	b	b	r	b	b		
12	r	r	r	r	r	b	b	b	r	b	b	b		
13	r	r	r	r	r	b	b	r	b	b	b	b		
14	r	r	r	r	r	b	r	b	b	b	b	b		
15	r	r	r	r	r	r	b	b	b	b	b	b		
16	r	r	r	r	r	r	b	b	b	b	r	b	b	
17	r	r	r	r	r	r	b	b	b	b	r	b	b	b
18	r	r	r	r	r	r	b	b	b	r	b	b	b	b
19	r	r	r	r	r	r	b	b	b	r	b	b	b	b
20	r	r	r	r	r	r	b	r	b	b	b	b	b	b
21	r	r	r	r	r	r	r	b	b	b	b	b	b	b

4 After everyone has had ample time to become involved in the situation and has produced some results, it is worth holding a class discussion to examine the different approaches that have been used. Pupils may need considerable help in formulating verbal or algebraic rules from their tables.

Number of counters	Number of moves
2	0
4	1
6	3
8	6
10	10
12	15
14	21
16	28

My theory is that the numbers it takes are all triangle numbers.

- 5 During the remainder of the lesson, some pupils may be able to explore the effect of starting from different arrangements. Encourage them to explore some variations of their own, and to share their discoveries, maybe via the blackboard.

Handwritten work on a blackboard:

$$\begin{array}{cccccccc}
 & \times 1 & \times 2 & \times 3 & \times 4 & \times 5 & \times 6 & \times 7 \\
 c & 4 & 6 & 8 & 10 & 12 & 14 & 16 \\
 m & 4 & 12 & 24 & 40 & 60 & 84 & 112 \\
 \hline
 & 8 & 12 & 16 & 20 & 24 & 28 &
 \end{array}$$

$$m = c \left[\frac{m}{2} - 1 \right]$$

- 6 It is important that pupils should be given adequate time to make a full write up of all their methods and findings, possibly for homework.

SOLUTIONS TO “SORTING”

- * For the alternating sequence RBRBRB . . . RB, the following pattern emerges:

Number of each colour (n)	1	2	3	4	5	6	...
Number of swaps needed (s)	0	1	3	6	10	15	...

The number of swaps needed are all “triangle numbers” and are related to the number of each colour by

$$s = \frac{n(n-1)}{2}$$

This can be seen by labelling each red counter:

$$R_1BR_2BR_3BR_4BR_5B \dots R_nB$$

Then R_i ($i=1, \dots, n$) must move $i-1$ places to the left. (Once this has happened, all the blues will automatically be in the correct position).

Thus, $\frac{n(n-1)}{2}$ moves are needed altogether.

For 50 red and 50 blue counters, $\frac{50 \times 49}{2} = 1225$ moves are needed.

- * When the counters are placed in alternating pairs RRBBRRBB . . . RRBB, the following pattern emerges:

Number of each colour (n)	2	4	6	8	10	...
Number of swaps needed (s)	0	4	12	24	40	...

and the formula is

$$s = \frac{n(n-2)}{2}$$

So for 50 red and 50 blue counters, $\frac{50 \times 48}{2} = 1200$ moves are needed.

* For the RBBRRBBRRBB . . . RBBR pattern

Number of each colour (n)	2	4	6	8	10	...
Number of swaps needed (s)	2	8	18	32	50	...

And the formula is

$$s = \frac{n^2}{2}$$

So for 50 red and 50 blue counters, $\frac{50^2}{2} = 1250$ more moves are needed.

* For 3 colours in the pattern RBGRBGRBG . . . RBG:

Number of each colour (n)	1	2	3	4	5	...
Number of swaps needed (s)	0	3	9	18	30	...

And the formula is

$$s = \frac{3n(n-1)}{2}$$

This can be seen by imagining that we move all the reds to the left to begin with. This will take $2 \times \frac{n(n-1)}{2}$ moves, since each red now hops BG, where before it was merely B.

When all the reds have moved we are left with

RRR . . . RBGBGBGBG . . . BG

and the blues and greens can be sorted with a further $\frac{n(n-1)}{2}$ moves,

making $\frac{3n(n-1)}{2}$ altogether.

- * For 4 colours in the pattern RBGWRBGW . . .

Number of each colour (n)	1	2	3	4	5	. . .
Number of swaps needed (s)	0	6	18	36	60	. . .

And the formula is

$$s=3n(n-1)$$

This can be explained in a similar manner to the previous case.

To move the reds to the left-hand end we need $\frac{3n(n-1)}{2}$ moves;

The whites can now be moved to the right-hand end in $\frac{2n(n-1)}{2}$ moves;

The blue and green counters can now be sorted with a further $\frac{n(n-1)}{2}$ moves;

Which makes a total of $\frac{6n(n-1)}{2}=3n(n-1)$ moves altogether.

- * For m colours in a similar cyclic pattern;

$$s=\frac{m(m-1)}{2}\times\frac{n(n-1)}{2}$$

PAPER FOLDING

For this investigation, you will need a scrap of paper.

Fold it in half, and then in half again. In both cases you should fold left over right. Open it out and look at the folded creases:

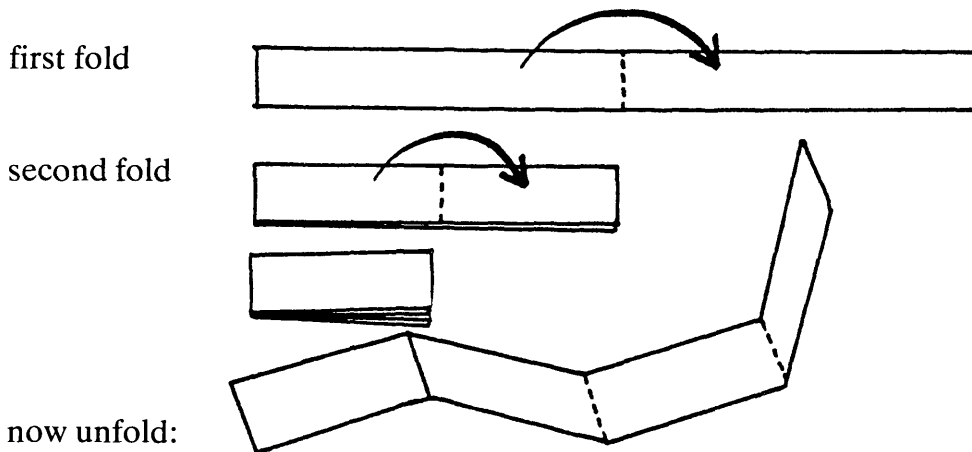

You should see 3 creases — one “up” and two “down”.

- * Now suppose you were able to fold your paper strip in half, left over right, 6 times, and then unfold it completely.

Predict the total number of creases you would get.

How many of these are “up” creases and how many are “down”?

What order would these creases come in?

- * Explain how you can predict the number and order of creases for 7, 8, . . . folds.
- * Try folding the paper in a different way and explore the patterns in the positioning and number of your creases. Write about your findings.

For example, here is a tricky two-step case . . .

Left to right *then*
Bottom to top . . .

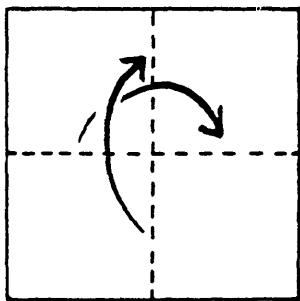

and
again . . .

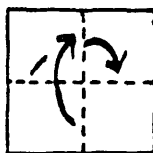

and
unfold . . . (gasp!)

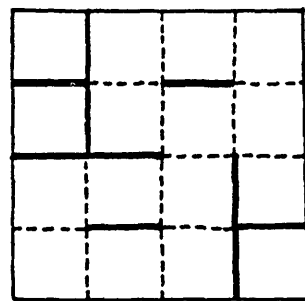

Any patterns?

PAPER FOLDING . . . PUPIL'S CHECKLIST

-
- | | |
|------------------------------|--|
| Try some simple cases | <ul style="list-style-type: none">* It is very difficult to fold a normal sheet of paper in half 6 times. (Just think how thick it will be!), so try just a few folds first. |
|------------------------------|--|
-
- | | |
|----------------------|--|
| Be systematic | <ul style="list-style-type: none">* Make sure that you always fold from left to right — don't turn your paper over in between folds! |
|----------------------|--|
-
- | | |
|--------------------------------------|--|
| Find a helpful representation | <ul style="list-style-type: none">* Invent symbols for "up" and "down" creases.* Use your symbols to record your results. |
|--------------------------------------|--|
-
- | | |
|---------------------|--|
| Make a table | <ul style="list-style-type: none">* Make a table to show the relationship between the number of times the paper is folded and the number of upward and downward creases, and also the <i>order</i> in which these creases occur. |
|---------------------|--|
-
- | | |
|----------------------|--|
| Spot patterns | <ul style="list-style-type: none">* Write about any patterns you find in your table. Can you explain <i>why</i> they occur?* Use these patterns to extend the table.* Check that you were right. |
|----------------------|--|
-
- | | |
|--------------------|--|
| Find a rule | <ul style="list-style-type: none">* Use your patterns to find rules that apply to any number of folds. |
|--------------------|--|
-
- | | |
|------------------------|---|
| Check your rule | <ul style="list-style-type: none">* Test your rules on large and small numbers of creases.* Try to explain <i>why</i> they work. |
|------------------------|---|
-
- | | |
|---------------------------|---|
| Extend the problem | <ul style="list-style-type: none">* Invent your own system of folding.* Try to <i>predict</i> what will happen, then check to see if you were right. |
|---------------------------|---|
-

B4 PAPER FOLDING

This situation generates an exponential sequence and provides pupils with an opportunity to devise their own notation to describe a practical situation.

Suggested Presentation

- 1 *Either* hand out the worksheet together with some scrap paper and allow the pupils time to read it through and explore some ideas.

Or you may prefer to present the situation orally as an exercise in visualisation:

“Shut your eyes everyone. Now imagine a long white strip of paper lying on the table in front of you. Hold each end. Now fold the paper by moving your left hand over to your right, and make a crease along the folded edge with your left hand. Now, grasping the creased end with your left hand, fold it again by moving your left hand towards your right, and make another crease. Now slowly imagine the paper unfolding. What does it look like . . .?”

This kind of mental manipulation is usually challenging and enjoyable, and can result in a very interesting discussion with pupils attempting to describe what they see.

- 2 Now invite the pupils to investigate the number and order of creases for different numbers of folds. In order to record their results, they will need to invent their own symbols for upward and downward folds. Again, a checklist of strategic hints has been provided, but by now most pupils may not need it.
- 3 As an extension, invite pupils to explore their own methods of folding, and to record patterns and results. The suggested example is very difficult, but it does show the possibility of using 2-dimensional folds. Pupils will probably not be able to arrive at any more formulae, but they may well become very involved in trying to find and predict patterns in the number, type and order of creases.

SOLUTIONS TO “PAPER FOLDING”

When the paper is folded twice, we get one upward crease (Λ shaped) and two downward creases (V shaped). We will denote this by ΛVV . The following diagram shows the pattern and the number of creases that are generated after each fold.

<i>Number of folds</i>	<i>Pattern of folds</i>	<i>“Up creases”</i>	<i>“Down creases”</i>	<i>Total</i>
1	V	0	1	1
2	$\Lambda V V$	1	2	3
3	$\Lambda \Lambda V V \Lambda V V$	3	4	7
4	$\Lambda \Lambda V \Lambda \Lambda V V V \Lambda \Lambda V V \Lambda V V$	7	8	15
.				
.				
<i>n folds</i>		$2^{n-1}-1$	2^{n-1}	2^n-1

One way of obtaining each sequence of folds from the previous one is by:

(i) writing V in the middle of the page:

V

(ii) following this V with the previous sequence:

$V \quad \Lambda \Lambda V \Lambda \Lambda V V V \Lambda \Lambda V V \Lambda V V$

(iii) and preceding this V with the previous sequence, but with the middle V changed to a Λ (ringed)

$\Lambda \Lambda V \Lambda \Lambda V V \textcircled{\Lambda} \Lambda \Lambda V V \Lambda V V \quad V \quad \Lambda \Lambda V \Lambda \Lambda V V V \Lambda \Lambda V V \Lambda V V$

This method gives the following answer for 6 folds:
(writing Λ^2 for $\Lambda \Lambda$ etc.)

$\Lambda^2 V \Lambda^2 V^2 \Lambda^3 V^2 \Lambda V^2 \Lambda^3 V \Lambda^2 V^3 \Lambda^2 V^2 \Lambda V^2 V \Lambda^2 V \Lambda^2 V^2 \Lambda^3 V^2 \Lambda V^2 V \Lambda^2 V \Lambda^2 V^3 \Lambda^2 V^2 \Lambda V^2$

A total of 31 ($=2^{6-1}-1$) “Up” creases, 32 ($=2^{6-1}$) “Down” creases, making a total of 63 ($=2^6-1$) creases altogether.

The suggested extension leads to the following table:
 (one-step means folding left to right then bottom to top)
 (two-steps means doing this process twice etc.)

Number of Steps	“Up” Folds	“Down” Folds	Total
1	1	3	4
2	10	14	24
3	52	60	112
⋮	⋮	⋮	⋮
n	$2^{n-1}(2^{n+1}-3)$	$2^{n-1}(2^{n+1}-1)$	$2^{n+1}(2^n-1)$

Although the algebra is very difficult, there are many patterns in the positioning of the creases which make this extension worthwhile for the more able.

Unit C

CONTENTS

Introduction		95
<hr/>		
C1 Laser Wars	The game	96
	Strategy checklist	97
	Solution	97
<hr/>		
C2 Kayles	The game	98
	Strategy checklist	99
	Solution	99
<hr/>		
C3 Consecutive Sums	The situation	100
	Strategy checklist	101
	Solutions	101



INTRODUCTION

The first two problems in this Unit are in the form of games. In both cases, there is a very simple strategy for winning which appeals to an argument based on symmetry. As it is hard to understand rules by just reading them, we recommend that you ask two pupils to play the game once or twice on the blackboard or using simple practical aids in front of the class, in order to clear up any misunderstandings. For example, “Kayles” (page 98) can be played by removing paper cups, books, or even children(!) from a line. This approach also gives you an opportunity to encourage children to think strategically at various points in the game; “What should Anne do next? Why? . . .”

In the “Consecutive sums” situation there are very many patterns to be found. As before, much progress can be made with numbers alone, but an algebraic approach will provide greater insights and challenges. This is a more open investigation with emphasis on children asking their own questions.

In this Unit you will notice that we have omitted the teacher’s notes, and have changed the “Pupil’s Checklists” to “Strategy Checklists”. This is because these situations can be presented in a similar way to those in Unit B, except that the checklists should not now be issued to pupils. They are included here to provide *the teacher* with a list of suggested oral hints, only to be given to pupils in difficulty.

LASER-WARS

 and  represent two tanks armed with laser beams that annihilate anything which lies to the North, South, East or West of them. They move alternately. At each move a tank can move any distance North, South, East or West but cannot move across or into the path of the opponent's laser beam. A player loses when he is unable to move on his turn.

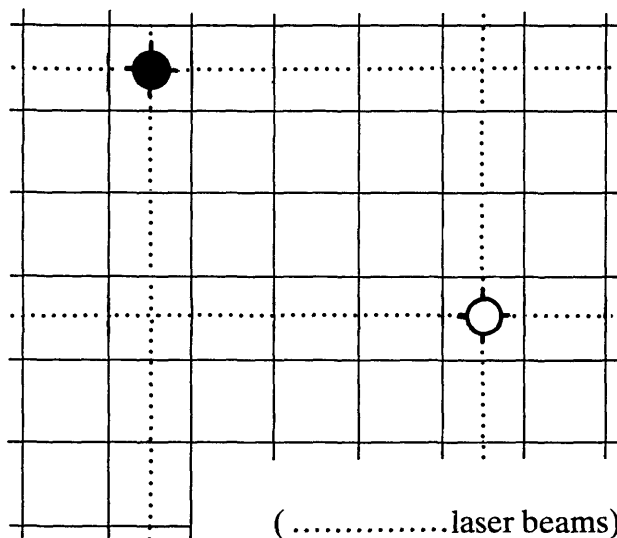

- * Play the game on the board below, using two objects to represent the "tanks". Try to find a winning strategy, which works *wherever* the tanks are placed to start with.

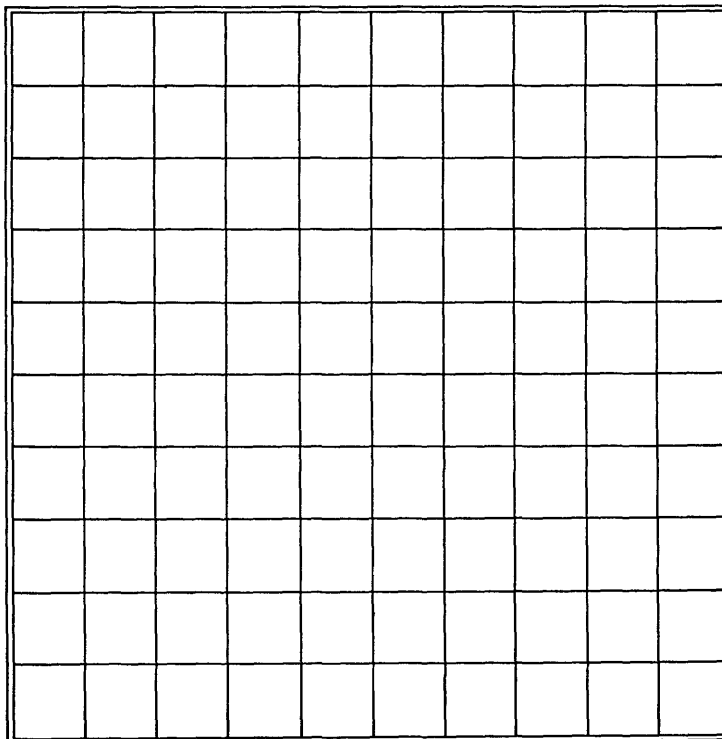

- * Now try to change the game in some way . . .

LASER-WARS . . . STRATEGY CHECKLIST

Try some simple cases	<ul style="list-style-type: none"> * Try playing on a smaller board. Try playing just the end of the game.
------------------------------	--

Be systematic	<ul style="list-style-type: none"> * Try starting from different positions in a systematic way.
----------------------	--

Spot patterns	<ul style="list-style-type: none"> * Find positions from which you can <i>always</i> win or from which you <i>must</i> lose. * Are there other positions from which you can always reach winning positions? * Look for symmetry in the game.
----------------------	---

Find a rule	<ul style="list-style-type: none"> * Write down a description of “how to win this game”. Explain why you are sure it works. * Extend your rule so that it applies to large boards.
--------------------	--

Check your rule	<ul style="list-style-type: none"> * Try to beat someone who is playing according to your rule. * Can you convince them that it always works?
------------------------	---

Change the game	<ul style="list-style-type: none"> * Limit the number of squares that can be moved by the vehicles. * Change the direction in which the lasers fire. * Change the playing area. (E.g.: use a triangular grid). * Try 3 players. (One vehicle each)
------------------------	--

LASER-WARS . . . A SOLUTION

If the first player always moves to a square such that an imaginary line joining the two tanks lies along a diagonal, then he must win.

(In the illustration,  would move to position A).

Whenever the second player moves, the first player can maintain or shorten the length of this diagonal until the second player is trapped in a corner.

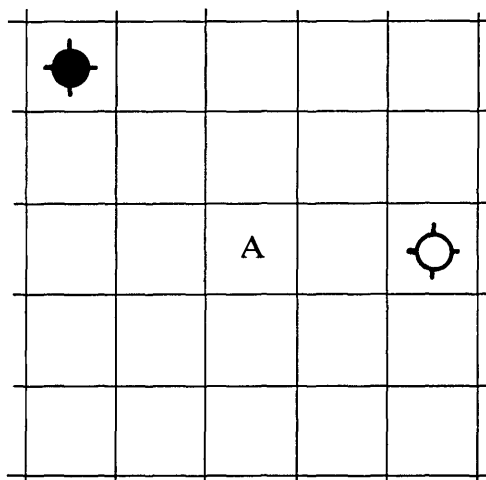

(Of course, if the initial positions of the tanks are such that they are already diagonally opposite each other, then the second player can win by the same strategy).

KAYLES

This is like an old 14th century game for 2 players, in which a ball is thrown at a number of wooden pins standing side by side:

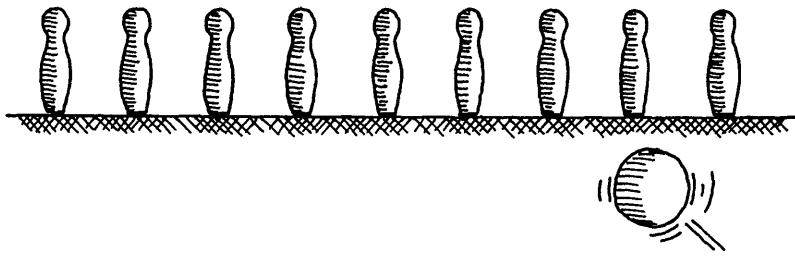

The size of the ball is such that it can knock down either a single pin or two pins standing next to each other. Players alternately roll a ball and the person who knocks over the last pin (or pair of pins) wins.

Try to find a winning strategy. (Assume that you can always hit the pin or pins that you aim for, and that no one is ever allowed to miss).

Now try changing the rules . . .

KAYLES . . . STRATEGY CHECKLIST

Try some simple cases	<ul style="list-style-type: none">* Try starting with just a few pins.Try playing just the end of a game.
Be systematic	<ul style="list-style-type: none">* Try starting with different numbers of pins in a systematic way.
Find a helpful representation	<ul style="list-style-type: none">* Don't bother trying to draw elaborate pictures.
Spot patterns	<ul style="list-style-type: none">* Look for positions from which you <i>must</i> win.* Look for symmetry in the game.
Find a rule	<ul style="list-style-type: none">* Write down a full description of how to win the game.* Extend your rule so that it applies to any number of pins.
Check your rule	<ul style="list-style-type: none">* Try to beat someone who is playing according to your rule.* Can you convince <i>them</i> that it always works?
Change the game	<ul style="list-style-type: none">* Suppose the player who knocks over the last pin <i>loses</i>.* Change the starting arrangement of pins. e.g. suppose they are in a <i>circle</i> surrounding both players . . . e.g. suppose there is a pin missing:— <div data-bbox="642 1406 1315 1518" data-label="Image"></div> <ul style="list-style-type: none">* Change the size of the ball so that it can knock down up to 3 pins.

KAYLES . . . A SOLUTION

If there are an odd number of pins, the first player should knock down the centre pin. If there are an even number, he should knock down the middle two. This splits the pins into two identical groups. Whatever the second player does to one group, the first player can replicate with the second group. This must mean that the first player will knock down the last pin (or pins) and win.

CONSECUTIVE SUMS

The number 15 can be written as the sum of consecutive whole numbers in three different ways:

$$15=7+8$$

$$15=1+2+3+4+5$$

$$15=4+5+6$$

The number 9 can be written as the sum of consecutive whole numbers in two ways:

$$9=2+3+4$$

$$9=4+5$$

Look at numbers *other than* 9 and 15 and find out all you can about writing them as sums of consecutive whole numbers.

Some questions you may decide to explore . . .

Which numbers *cannot* be written as consecutive sums?

What kinds of numbers can be written as the sum of 2 or 3 or 4 or . . . consecutive numbers?

How many ways can various numbers be produced?

Spaces for your own questions when you think of any.

Write about your discoveries.
Try to explain *why* they occur.

CONSECUTIVE SUMS . . . STRATEGY CHECKLIST

Try some simple cases	* Try writing some small numbers as sums of consecutive numbers.
Be systematic	* Don't just choose these numbers at random.
Make a table	* Organise your results in a tabular form.
Spot patterns	<ul style="list-style-type: none"> * Write about <i>any</i> patterns you can find in your table. * Write down any good questions which occur to you. * Use these patterns to extend the table and make predictions. * Check that your predictions were right.
Find a rule	* Use the patterns to find rules which apply to any numbers.
Check your rule	<ul style="list-style-type: none"> * Make sure your rule always works. * Test it on large and small numbers. * Try to explain <i>why</i> it works. (This may be quite hard).

CONSECUTIVE NUMBERS . . . SOLUTIONS

1=	11=5+6	21=10+11=6+7+8=1+2+3+4+5+6
2=	12=3+4+5	22=4+5+6+7
3=1+2	13=6+7	23=11+12
4=	14=2+3+4+5	24=7+8+9
5=2+3	15=7+8=4+5+6=1+2+3+4+5	25=12+13=3+4+5+6+7
6=1+2+3	16=	26=5+6+7+8
7=3+4	17=8+9	27=13+14=8+9+10=2+3+4+5+6+7
8=	18=5+6+7=3+4+5+6	28=1+2+3+4+5+6+7
9=4+5=2+3+4	19=9+10	29=14+15
10=1+2+3+4	20=2+3+4+5+6	30=9+10+11=6+7+8+9=4+5+6+7+8

Some observations

- 1 Powers of 2 cannot be written as consecutive sums.
- 2 Sums of 3 consecutive numbers are all multiples of 3(=3*m* where $m \geq 2$).
Sums of 5 consecutive numbers are all multiples of 5(=5*m* where $m \geq 3$).
.
.
Sums of $2n+1$ ($n \geq 1$) consecutive numbers are all multiples of $2n+1$
(= $(2n+1)m$, $m \geq n+1$).
- 3 Sums of 2 consecutive numbers are all odd (=2*m*+1, $m \geq 1$).
Sums of 4 consecutive numbers are always 2 greater than multiples of 4
(= $4m+2$, $m \geq 2$).
.
.
Sums of $2n$ ($n \geq 1$) consecutive numbers are of the form $2mn+n$ ($m \geq n$).
- 4 Consider all the numbers which can only be written as a consecutive sum in one way.
If the sum has just 2 terms, we get the prime numbers 3, 5, 7, 11, 13, 17 . . .
If the sum has 3 terms, we get: 6, 12, 24 . . .
If the sum has 4 terms, we get: 10, 14, 22, 26 . . .
If the sum has 5 terms, we get: 20 . . .
These patterns seem to be fairly obscure, until you notice that all these numbers are of the form $2^n \times \text{prime}$. The following table makes this clearer:

<i>p</i> :—	3	5	7	11	13	17
$2p$:—	6	10	14	22	26	34
$4p$:—	12	20	28	44	52	..
$8p$:—	24	40	56	88	104	..
$16p$:—	48	80	112	176	..	

This arrangement lists all the above numbers according to the number of factors that each possesses. (The first row contains all the numbers with just two factors, the second row contains all the numbers with four factors, . . . and the *n*th row contains all the numbers with $2n$ factors).

- 5 In a similar fashion, we can make a list of all those numbers expressible as consecutive sums in exactly 2 ways:

p^2 :—	9	25	49	121	...
$2p^2$:—	18	50
$4p^2$:—	36	100
$8p^2$:—	72				

- 6
.
.
.

A Problem Collection

CONTENTS

Introduction		105
<hr/>		
Problems	The Painted Cube	106
	Score Draws	108
	Cupboards	110
	Networks	112
	Frogs	114
	Dots	116
	Diagonals	118
	The Chessboard	120
<hr/>		
Games for Two Players	The Spiral Game	124
	Nim	126
	First One Home	128
	Pin Them Down	130
	The “Hot Fat Tune” Game	132
	Domino Square	134
	The Treasure Hunt	136

INTRODUCTION

This collection of problems and games can be used at any time to supplement the classroom materials presented in Units A, B and C, and of course, to stimulate problem solving activities and investigations at any time during the school year.

THE PAINTED CUBE

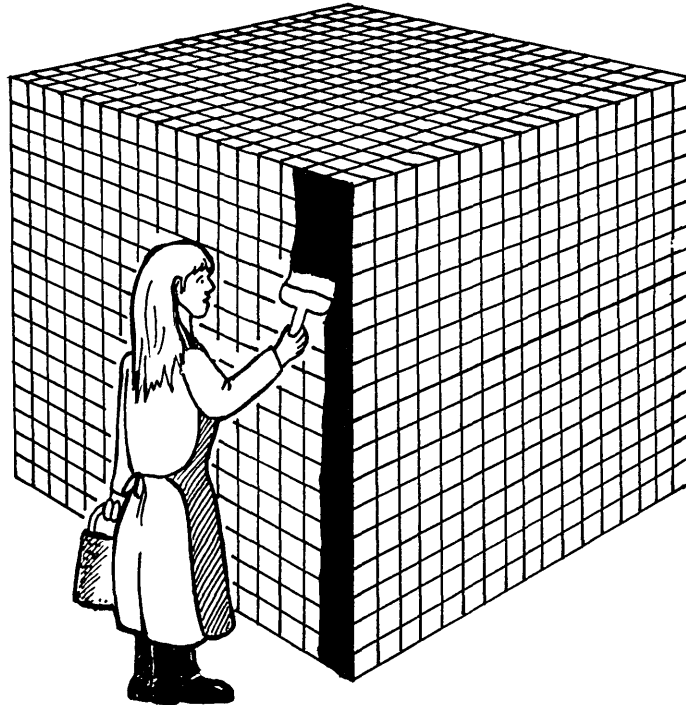

- * Imagine that the six outside surfaces of a large cube are painted black. This large cube is then cut up into 4,913 small cubes. ($4,913 = 17 \times 17 \times 17$).

How many of the small cubes have:

- 0 black faces?
 - 1 black face?
 - 2 black faces?
 - 3 black faces?
 - 4 black faces?
 - 5 black faces?
 - 6 black faces?
- * Now suppose that you cut the cube into n^3 small cubes . . .

SOLUTIONS TO THE “PAINTED CUBE”

* When the cube is cut into 4,913 small cubes:

3375 ($=15^3$)	will have no black faces
1350 ($=6 \times 15^2$)	will have one black face
180 ($=12 \times 15$)	will have two black faces
8	will have three black faces

* In general, when the cube is cut into n^3 small cubes:

$(n-2)^3$	will have no black faces
$6(n-2)^2$	will have one black face
$12(n-2)$	will have two black faces
8	will have three black faces

Note that $n^3 = (n-2)^3 + 6(n-2)^2 + 12(n-2) + 8$

SCORE DRAWS



“At the final whistle, the score was 2—2”

What was the half time score? Well, there are nine possibilities:

0—0; 1—0; 0—1; 2—0; 1—1; 2—1; 2—2; 1—2; 0—2

- * Now explore the relationship between other drawn matches, and the number of possible half-time scores.

There are six possible ways of reaching a final score of 2—2:

1. 0—0, 1—0, 2—0, 2—1, 2—2
2. 0—0, 1—0, 1—1, 2—1, 2—2
3. 0—0, 1—0, 1—1, 1—2, 2—2
4. 0—0, 0—1, 1—1, 2—1, 2—2
5. 0—0, 0—1, 1—1, 1—2, 2—2
6. 0—0, 0—1, 0—2, 1—2, 2—2

- * How many possible ways are there of reaching other drawn matches?
- * Finally, consider what happens when the final score is *not* a draw.

SOLUTIONS TO “SCORE DRAWS”

- * The following table shows the relationship between the final score and the number of possible half-time scores that may have occurred.

Final Score	0—0	1—1	2—2	3—3	4—4	$n—n$
Number of possible half-time scores	1	4	9	16	25	$(n+1)^2$

- * The number of possible routes to a particular score is closely related to Pascal’s Triangle.

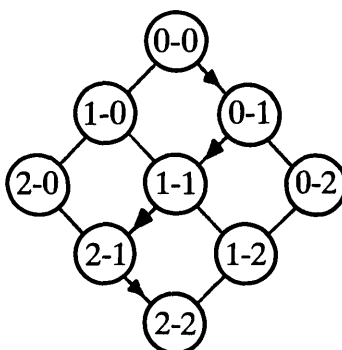

The particular route shown above is 0—0; 0—1; 1—1; 2—1; 2—2.

The number of paths to each score on this diagram is given below:

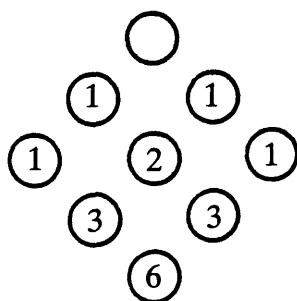

Thus there are 3 routes to a score of 2—1, and 6 routes to a score of 2—2.

By extending this pattern, we arrive at the following table:

Final Score	0—0	1—1	2—2	3—3	4—4	$n—n$
Number of paths to this score	1	2	6	20	70	$\frac{(2n)!}{(n!)^2}$

- * When the final score is $m—n$ ($m \neq n$) then there are $(m+1)(n+1)$ possible half-time scores, and the final score may have been reached in $\frac{(m+n)!}{m!n!}$ ways.

CUPBOARDS

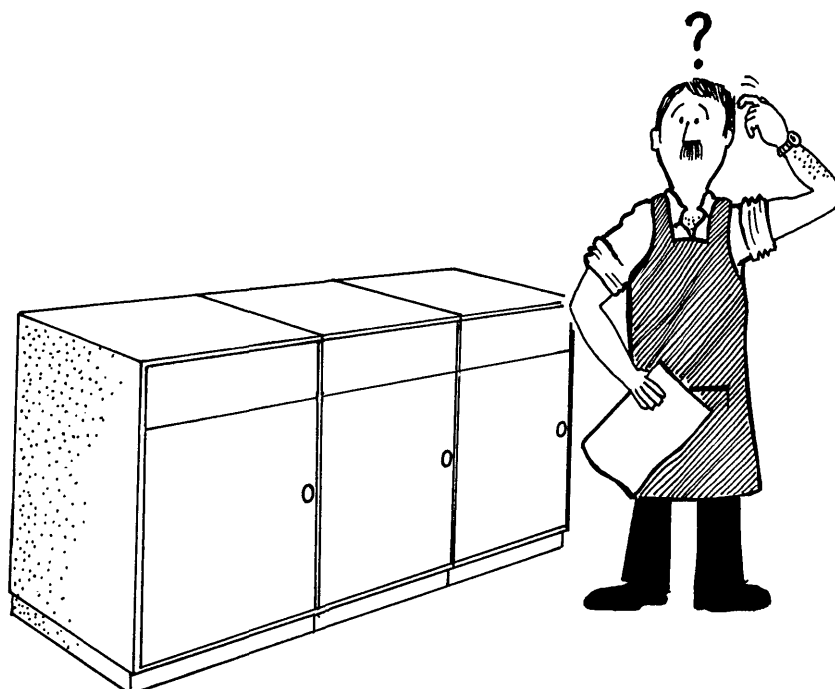

A factory sells cupboards in two standard widths: 5 dm and 7 dm.
(Note: 1 dm = 1 decimetre = 10 centimetres).

By placing combinations of these cupboards end to end, they can be fitted into rooms of various sizes.

For example, two 5 dm and three 7 dm cupboards can be fitted into a room 31 dm long.

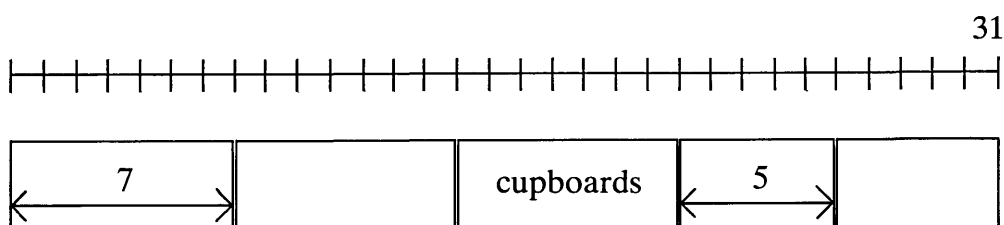

- * How can you fit a room 32 dm long?
- * Explore rooms with different lengths. Which ones can be fitted exactly with cupboards. Which cannot?
- * Suppose the factory decides to manufacture cupboards in 4 dm and 7 dm widths. Which rooms cannot be fitted now?
- * Investigate the situation for other pairs of cupboard sizes.
Can you *predict* which rooms can or cannot be fitted?

SOLUTIONS TO “CUPBOARDS”

- * A room 32 dm long can be fitted with one 7 dm cupboard and five 5 dm cupboards.
- * The diagram below shows all the possible room sizes up to 31 dm that can be fitted with the cupboards.

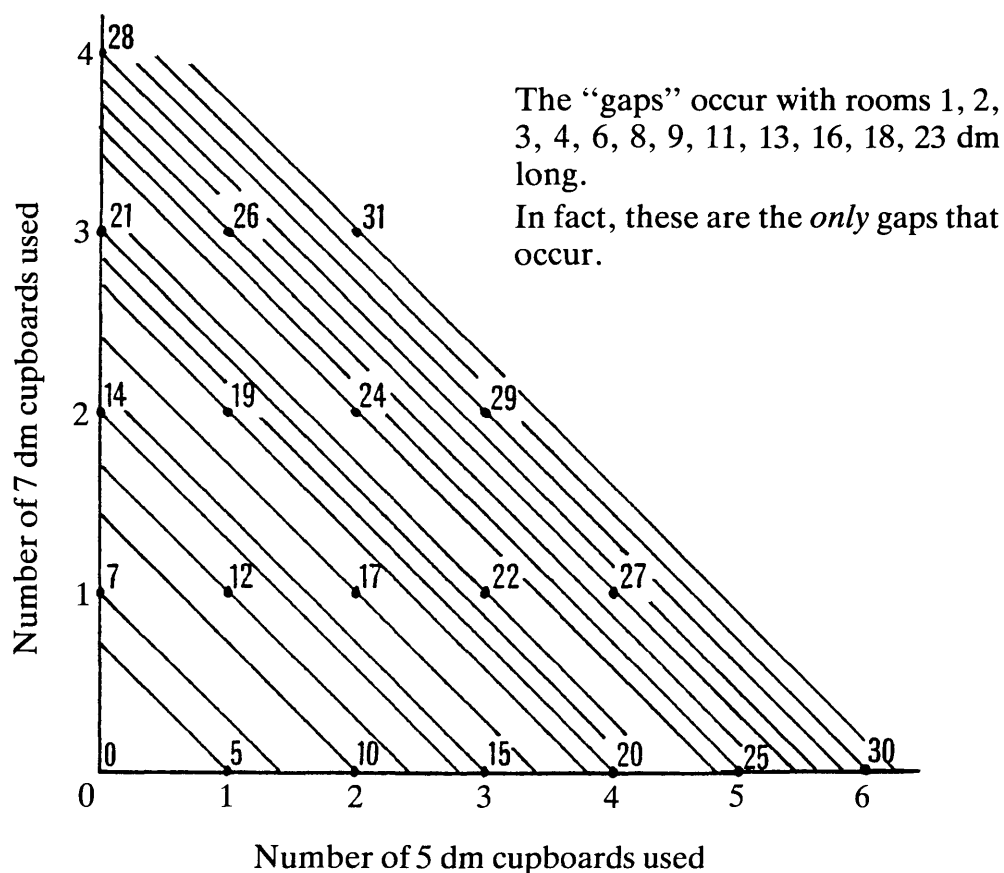

- * Using cupboards in 4 dm and 7 dm widths, the following rooms cannot be fitted: 1, 2, 3, 5, 6, 9, 10, 13, 17 dm. All integral rooms above 17 dm may be fitted exactly.
- * In general, the *largest room* which cannot be fitted with cupboards of size x dm and y dm is $xy - (x + y)$ dm long, provided that x and y have no non-trivial common factors. The *total number* of rooms that cannot be fitted (i.e. the number of “gaps”) is $\frac{1}{2}(x - 1)(y - 1)$.

NETWORKS

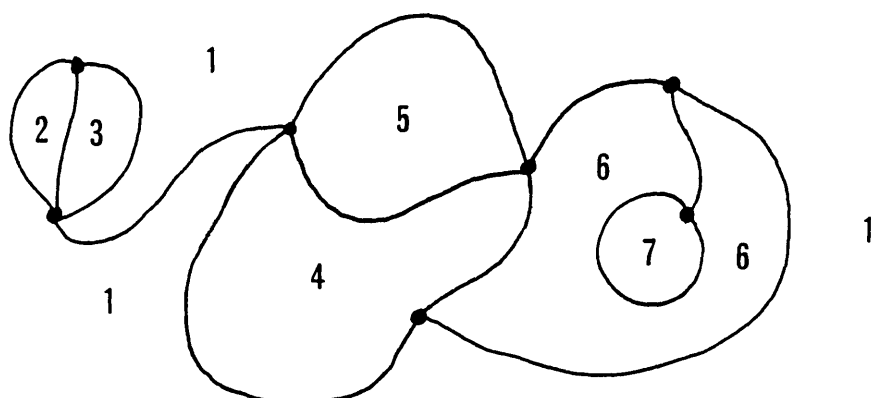

A network is a set of lines (or “arcs”), junctions (or “nodes”) and spaces (or “regions”) which compose a shape.

The network shown above is composed of 12 arcs, 7 nodes (marked with blobs) and 7 regions (these are numbered—notice that we have included the outside as a region).

Networks can be of two kinds:

Connected, like this . . .

or disconnected like this . . .

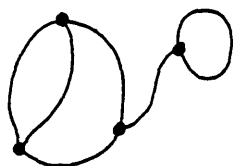

Draw your own connected networks. Find a rule connecting the number of arcs, nodes and regions. Try to explain why your rule works.

Can you adapt your rule to work for disconnected networks?

A cube has 6 faces, 8 corners (or vertices) and 12 edges.

Explore the relationship between the number of faces, vertices and edges for other solid shapes.

Can you find any exceptional cases?

SOLUTIONS TO “NETWORKS”

If a *connected* network has a arcs, n nodes and r regions, then

$$n+r-a=2 \quad \textcircled{1}$$

If a *disconnected* network consists of c connected parts, then

$$n+r-a=1+c \quad \textcircled{2}$$

For polyhedra, similar results can be obtained.

In particular, for the five regular polyhedra with f faces, v vertices and e edges

$$v+f-e=2 \quad \textcircled{3}$$

The equivalence of the results to $\textcircled{1}$ and $\textcircled{3}$ can be seen if one face of the solid is removed and the rest is topologically stretched and distorted until the solid lies on a plane.

The diagram below shows this operation being performed on a cube.

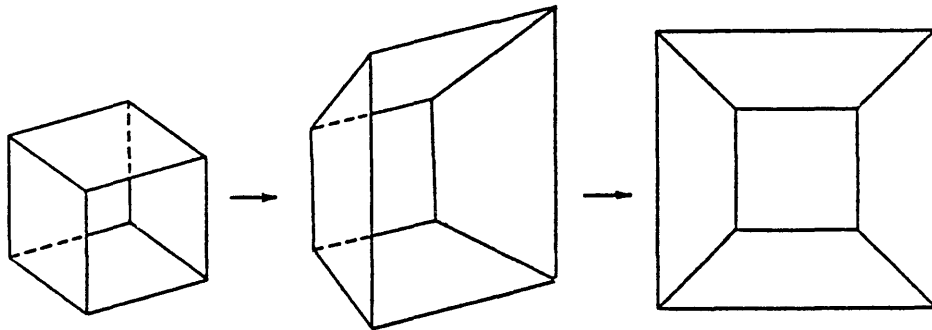

This “Schlegel” diagram, as it is called, demonstrates the correspondence between faces and regions, edges and arcs, and vertices and nodes. (The face which was removed to begin the distortion must be seen to correspond to the outside region of the network).

Polyhedra with disconnected “Schlegel” diagrams will not obey the $v+f-e=2$ law, but will need adapting by a similar process to equation $\textcircled{2}$.

The following solid is just one example.

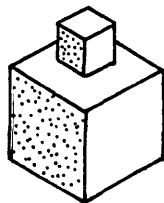

$$\left. \begin{array}{l} v=16 \\ f=11 \\ e=24 \end{array} \right\} v+f-e=3$$

This, however, is not an exhaustive analysis . . .

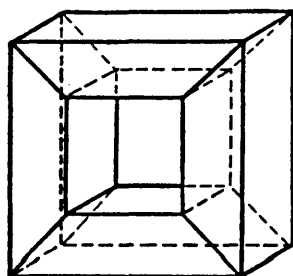

$$\left. \begin{array}{l} v=16 \\ f=16 \\ e=32 \end{array} \right\} v+f-e=0$$

FROGS



These two frogs can change places in three moves

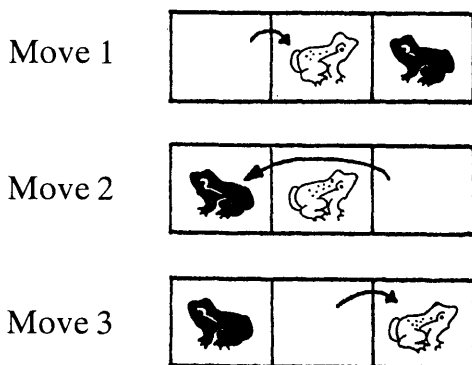

Rules

- * A frog can *either* hop onto an adjacent square, *or* jump over one other frog to the vacant square immediately beyond it.
- * The white frogs can only move from left to right the black frogs can only move from right to left.

The frogs shown below can be interchanged in 15 moves. Explain how.



How many moves would be needed to interchange 20 white and 20 black frogs?
 – n white and n black frogs?

Now suppose that there are an *unequal* number of black and white frogs.
 These frogs can be interchanged in 11 moves. Explain how.



How many moves are needed to interchange 15 white and 20 black frogs?
 – n white and m black frogs?

SOLUTIONS TO “FROGS”

In order to record moves it is helpful to invent a code.

One such code is to denote moving a black (white) frog to an adjacent square by b (w); jumping a black (white) frog over another frog by B (W).

The solution for 3 frogs of each colour is then given by:

$w, B, b, W, W, w, B, B, B, w, W, W, b, B, w.$

(An alternative code is to label the position of the vacant square).

440 moves are needed to interchange 20 frogs of each colour.

The following table shows the underlying patterns from which this may be deduced:

Number of frogs of each colour	1	2	3	4	5	...	n
Number of “jumps” over other frogs	1	4	9	16	25	...	n^2
Number of moves to adjacent squares	2	4	6	8	10	...	$2n$
Total Number of moves needed	3	8	15	24	35	...	n^2+2n

(Pupils may also notice that the final entry in each table is always one less than a perfect square. Thus $(n+1)^2 - 1 = n^2 + 2n$).

The method for interchanging two white and three black frogs is

$w, B, b, W, W, b, B, B, w, W, b$

For 15 white and 20 black frogs, 335 moves are needed.

The following table shows the number of moves needed for given numbers of white and black frogs:

		Number of white frogs				
		1	2	3	4	5
Number of black frogs	1	3	5	7	9	11
	2	5	8	11	14	17
	3	7	11	15	19	23
	4	9	14	19	24	29
	5	11	17	23	29	35

In general, for n white and m black frogs, $mn+m+n$ moves are needed, of which mn are jumps over other frogs and $m+n$ are hops onto adjacent squares.

DOTS

You will need a supply of
dotty paper.

The quadrilateral shown in
this diagram has an area of
 $16\frac{1}{2}$ square units.

The perimeter of the
quadrilateral passes through 9
dots.

13 dots are contained within
the quadrilateral.

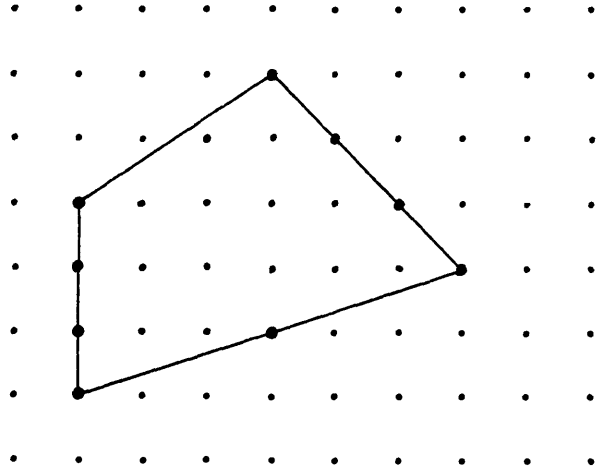

Now draw your own shapes and try to find a relationship between the area, the
number of dots on the perimeter and the number of dots inside each shape.

Try to find a similar result for a triangular dot lattice.
(You will of course have to redefine your unit of area).

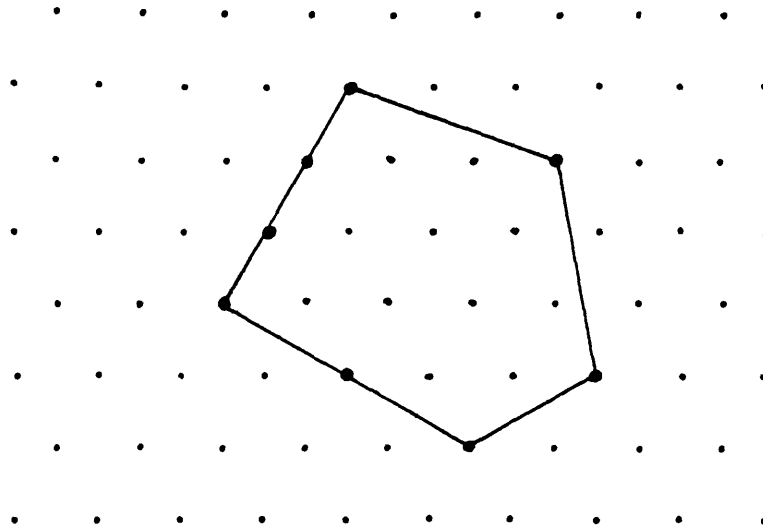

SOLUTIONS TO “DOTS”

For the square lattice, the relationship $a = \frac{1}{2}p + i - 1$ holds, where a = the area of the shape

p = the number of dots on the perimeter

i = the number of dots inside each shape

(This result is often known as Pick's theorem).

For the triangular lattice, this relationship becomes

$$a = 2\left(\frac{1}{2}p + i - 1\right) = p + 2i - 2$$

where a is now the area of the shape in triangular units.

DIAGONALS

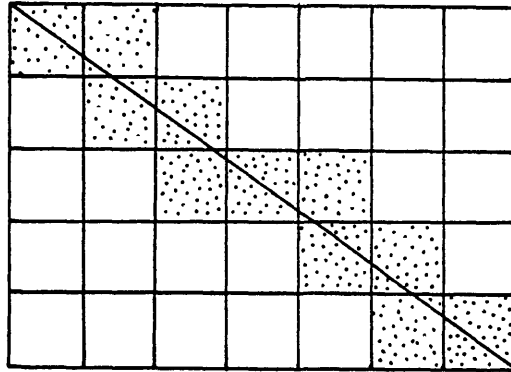

A diagonal of this 5×7 rectangle passes through 11 squares.

These have been shaded in the diagram.

- * Can you find a way of forecasting the number of squares passed through if you know the dimensions of the rectangle?

- * How many squares will the diagonal of a 1000×800 rectangle pass through?

SOLUTIONS TO “DIAGONALS”

The following table shows the number of squares passed through for a rectangle of given dimensions.

		length of rectangle							
		1	2	3	4	5	6	7	8
height of rectangle	1	1	2	3	4	5	6	7	8
	2	2	2	4	4	6	6	8	8
	3	3	4	3	6	7	6	9	10
	4	4	4	6	4	8	8	10	8
	5	5	6	7	8	5	10	11	12
	6	6	6	6	8	10	6	12	12
	7	7	8	9	10	11	12	7	14
	8	8	8	10	8	12	12	14	8

Suppose we have a rectangle with dimensions $a \times b$.

- * Then if a and b have no non trivial factors in common (i.e. are coprime) then the diagonal passes through $a+b-1$ squares.
- * If a and b have factors in common, so that $a=mp$ and $b=mq$ where p and q are coprime, then the diagonal passes through $m(p+q-1)$ squares.
For example, a 6×8 rectangle, $6=2 \times 3$ and $8=2 \times 4$, and the diagonal passes through $2(3+4-1)=12$ squares. (See diagram below.)

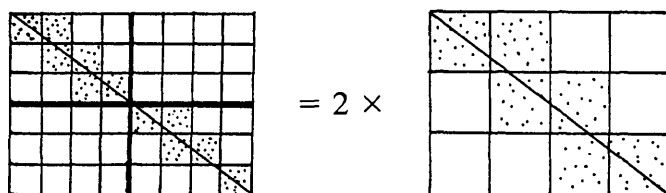

The diagonal of a 1000×800 rectangle will therefore pass through 1600 squares.

THE CHESSBOARD

- * How many squares are there on an 8×8 chessboard?
(Three possible squares are shown by dotted lines).
- * How many rectangles are there on the chessboard?
- * Can you generalise your results for an $n \times n$ square?

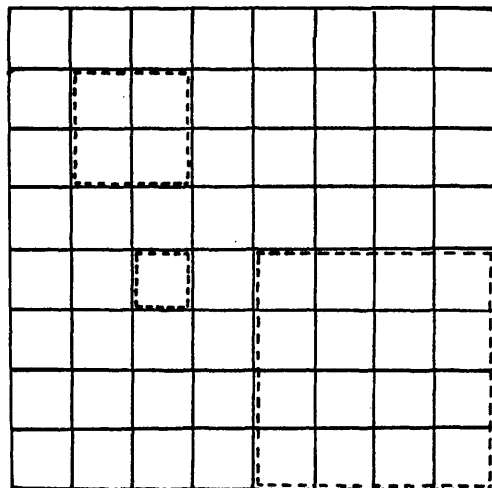

- * How many triangles are there on this 8×8 grid?
How many point upwards?
How many point downwards?
- * Look for other shapes in this grid and count them.

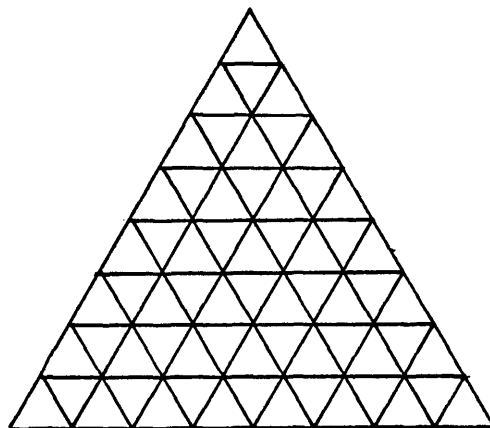

SOLUTIONS TO THE “CHESSBOARD” PROBLEM

- * There are 204 squares on a chessboard.

The table below illustrates one systematic way of obtaining this result:

Size of each square	Number of squares of this size
1×1	64=8 ²
2×2	49=7 ²
3×3	36=6 ²
4×4	25=5 ²
⋮	⋮
⋮	⋮
⋮	⋮
8×8	1=1 ²
Total	$204 = \sum_{r=1}^8 r^2$

- * There are 1296 rectangles on a chessboard.

The table below shows the number of rectangles that exist with any given dimension

		length of rectangle							
		1	2	3	4	5	6	7	8
width of rectangle	1	64	56	48	40	32	24	16	8
	2	56	49	42	35	28	21	14	7
	3	48	42	36	30	24	18	12	6
	4	40	35	30	25	20	15	10	5
	5	32	28	24	20	16	12	8	4
	6	24	21	18	15	12	9	6	3
	7	16	14	12	10	8	6	4	2
	8	8	7	6	5	4	3	2	1

In general, there are $(9-w)(9-l)$ rectangles with width w and length l .

Altogether, there are $(1+2+3+\dots+8)^2=1296$ rectangles.

Notice the pattern obtained if the numbers inside the  shapes are added together. This illustrates the surprising result that

$$(1+2+\dots+8)^2=1^3+2^3+3^3+\dots+8^3.$$

- * In general there are $\frac{1}{6}n(n+1)(2n+1)$ squares and $[\frac{1}{2}n(n+1)]^2$ rectangles on an $n \times n$ board.

- * There are 170 triangles on an 8×8 grid.
120 of these point upwards.
50 of these point downwards.

The following table gives the number that point upwards for each particular size:

Size of triangle	1×1	2×2	3×3	4×4	5×5	6×6	7×7	8×8
Number	36	28	21	15	10	6	3	1

The next table gives the number that point downwards for each particular size:

Size of triangle	1×1	2×2	3×3	4×4
Number	28	15	6	1

- * In general, for an $n \times n$ triangular grid:

There are $\frac{1}{6} n(n+1)(n+2)$ upward pointing triangles.

There are $\frac{1}{24} n(n+2)(2n-1)$ downward pointing triangles (when n is even) and

$\frac{1}{24} (n-1)(n+1)(2n+3)$ downward pointing triangles (when n is odd).

THE SPIRAL GAME

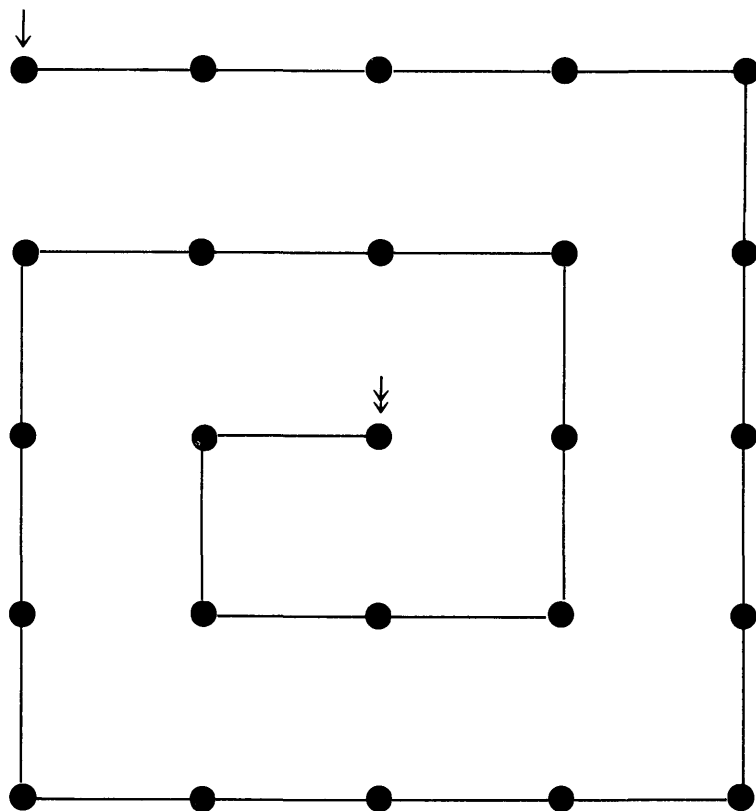

This is a game for two players. Place a counter on the dot marked “↓”. Now take it in turns to move the counter between 1 and 6 dots along the spiral, always inwards. The first player to reach the dot marked “↓” wins.

Try to find a winning strategy.

Change the rule for moving in some way and investigate winning strategies.

SOLUTIONS TO “THE SPIRAL GAME”

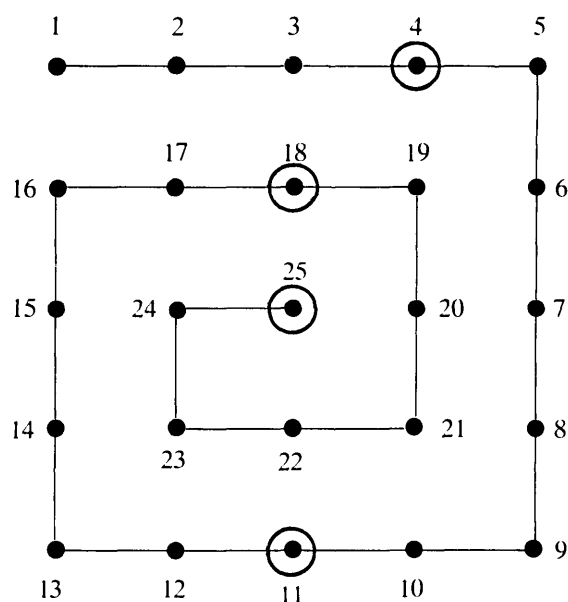

If the first player moves to position 4, then whatever the second player does, the first player can always land on 11, 18 and 25.

This game is isomorphic to the “First to 100” game in Unit B, and can be extended in a similar way.

e.g. if the first one to 25 *loses*, then the first player can always win by reaching the positions marked 3, 10, 17, 24.

In general, if the counter can be moved between a and b dots along the spiral, (the first one to 25 wins) then whichever player can first break into the sequence of numbers $25, 25-(a+b), 25-2(a+b), \dots$ must win.

NIM

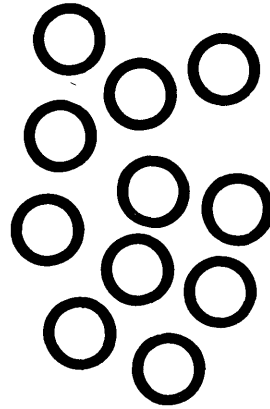
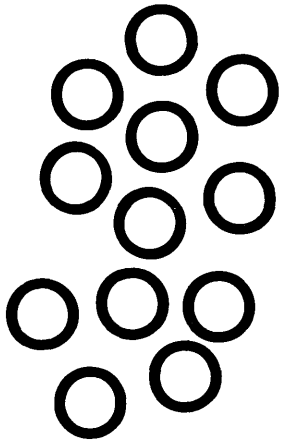

This is a game for 2 players.

Arrange a pile of counters arbitrarily into 2 heaps.

Each player in turn can remove as many counters as he likes from *one* of the heaps. He can, if he wishes, remove all the counters in a heap, but he must take at least one.

The winner is the player who takes the last counter.

Try to find a winning strategy.

Now change the game in some way and analyse your own version.

SOLUTIONS TO “NIM”

This is the simplest version of the game. If the two piles contain an equal number of counters then player 2 has a simple winning strategy. He simply copies any removals made by player 1, on the other pile, thus keeping their size equal. This ensures that he moves last, and wins. If the two piles are unequal, then player 1 should remove counters so that the two piles become equal. This case then reduces to the game with equal piles and player 1 must win.

Possible extensions

- * Play the game with 3 piles.
- * (Wythoff's game). Begin with two piles of counters.
The rules for removal are:
 1. You can pick up any or all the counters in one pile.
 2. You can pick up counters from both piles, providing you take the same number from each.
- * Restrict (say to 4) the maximum number of counters that can be removed at each turn.

“FIRST ONE HOME”

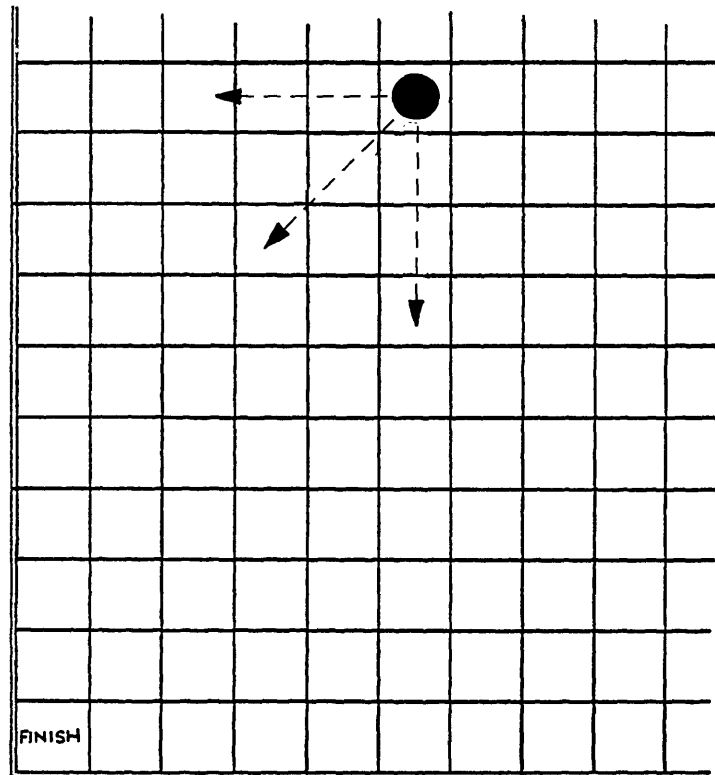

This game is for two players. You will need to draw a large grid like the one shown, for a playing area.

Place a counter on any square of your grid.

Now take it in turns to slide the counter *any number of squares* due West, South or Southwest, (as shown by the dotted arrows).

The first player to reach the square marked “Finish” is the winner.

SOLUTIONS TO “FIRST ONE HOME”

The player who can first move the counter onto a shaded (▨) square must win. Whatever the other player does, he cannot prevent this player from moving from shaded square to shaded square and eventually into the bottom left hand corner.

Notice that there is exactly one and only one shaded square in every row, column and North East-South West diagonal. It is interesting to try to find patterns in the coordinates of these shaded squares:

(1,1)
 (2,3) (3,2)
 (4,6) (6,4)
 (5,8) (8,5)
 (7,11) (11,7)
 (9,14) (14,9)
 (10,16) (16,10)
 (12,19) (19,12)

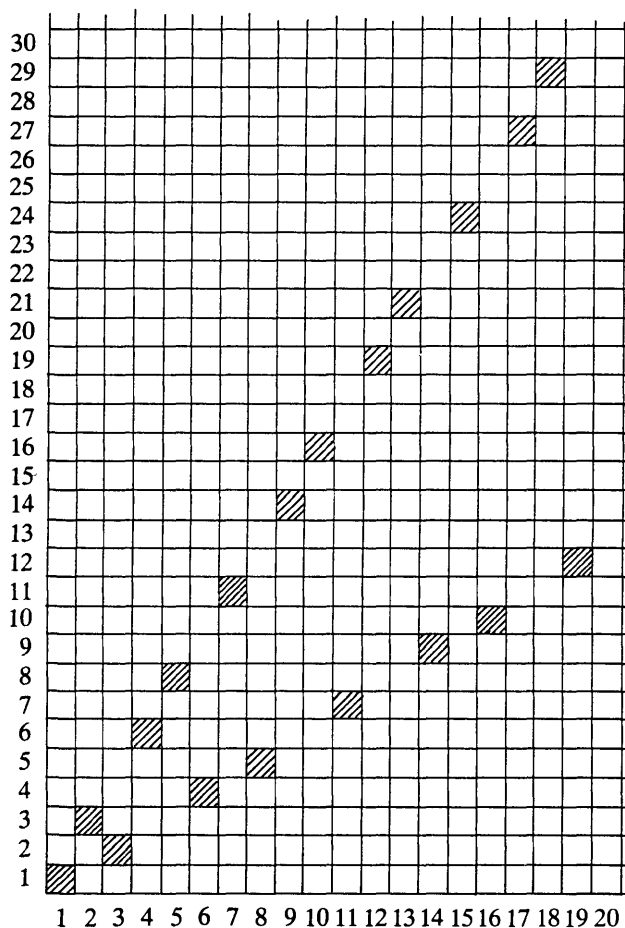

Notice that each value of x and y in (x, y) only occurs once, and that the difference between x and y increases by one each time we move down the list.

Possible extensions

- * Suppose that the first player to reach the bottom left hand square *loses*.
- * Limit the number of squares that the counter can move.
- * Use a hexagonal grid.

PIN THEM DOWN!

A game for 2 players.

Each player puts counters of his colour in an end row of the board. The players take it in turns to slide one of their counters up or down the board *any* number of spaces.

No jumping is allowed. The aim is to prevent your opponent from being able to move by pinning him to the wall.

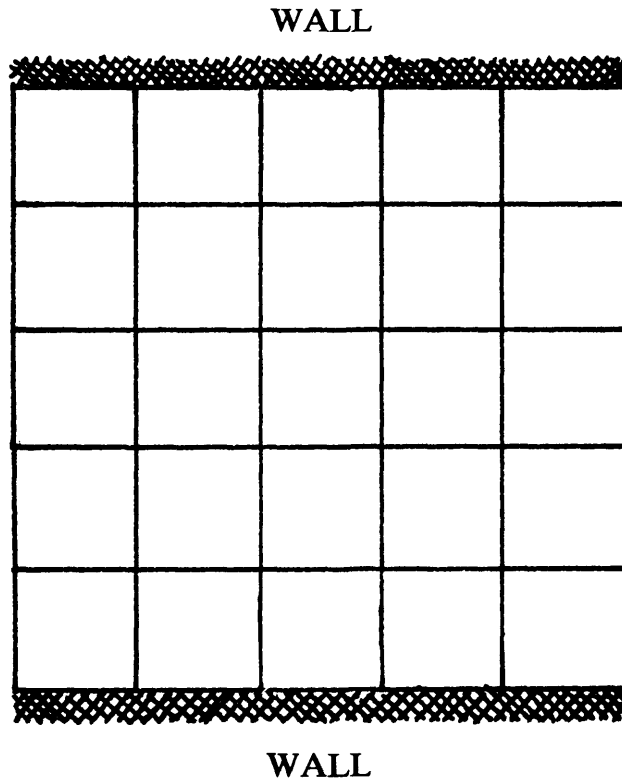
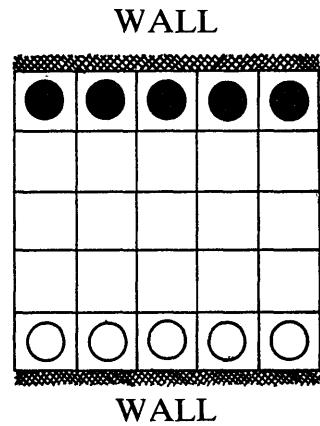

Can you find a winning strategy?

SOLUTION TO “PIN THEM DOWN”

This game should result in a win for the player who moves first. If white moves the centre piece as far forward as possible, then whatever piece black moves on one side of this column, white can imitate on the other side. (e.g. If black moves to *X* then white can imitate with *Y*). This kind of symmetrical play will ensure that white will have the last forward move, and then go on to win.

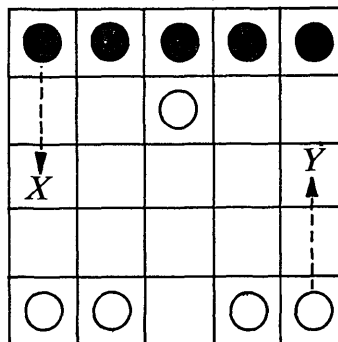

This winning strategy generalises to all boards with an odd number of columns. For boards with an even number, the player who moves second can always win by a similar imitative strategy. (In this case there is no centre piece to move).

Possible extensions

- * Generalise to any number of columns and rows.
- * Allow the starting positions to be anywhere, (but keep the white counters below their black counterparts).

i.e.

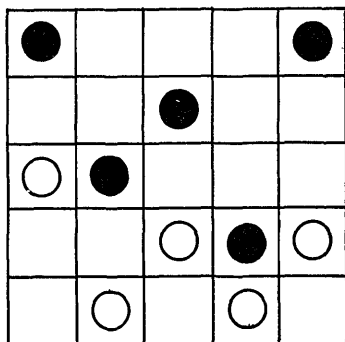

THE "HOT FAT TUNE" GAME

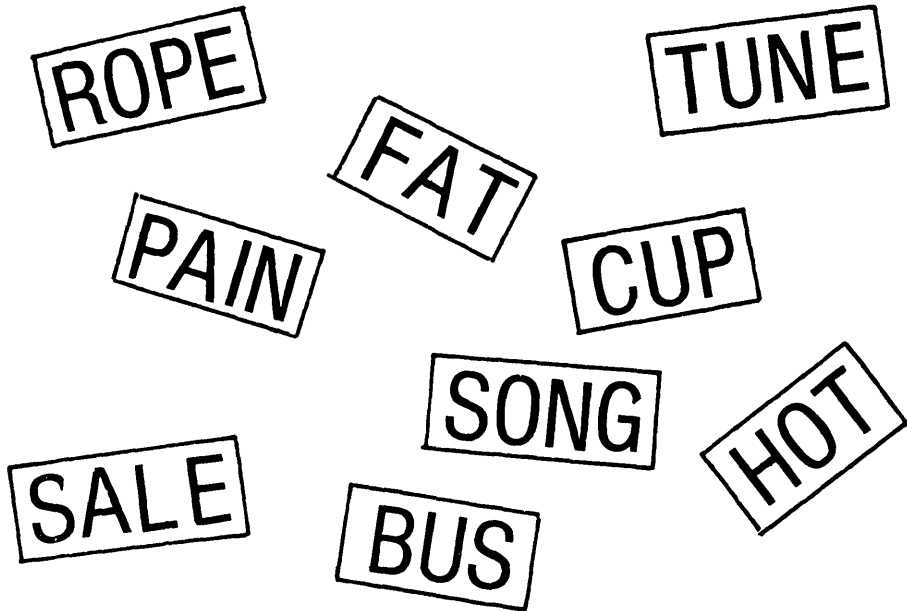

This is a game for two players.

Take it in turns to remove any one of the nine cards shown above.

The first player to hold three cards which contain the same letter is the winner.

Try to find a winning strategy.

SOLUTION TO THE “HOT FAT TUNE” GAME

This game is isomorphic to noughts and crosses played on the board shown below, where each row, column and diagonal contains three words with exactly one letter in common.

	E ↘	P ↓	T ↓	S ↓	
O →	ROPE	HOT	SONG		
U →	CUP	TUNE	BUS		
A →	PAIN	FAT	SALE		
	N ↗				

Possible extension

- * The first player to hold three cards bearing the same letter *loses!*

DOMINO SQUARE

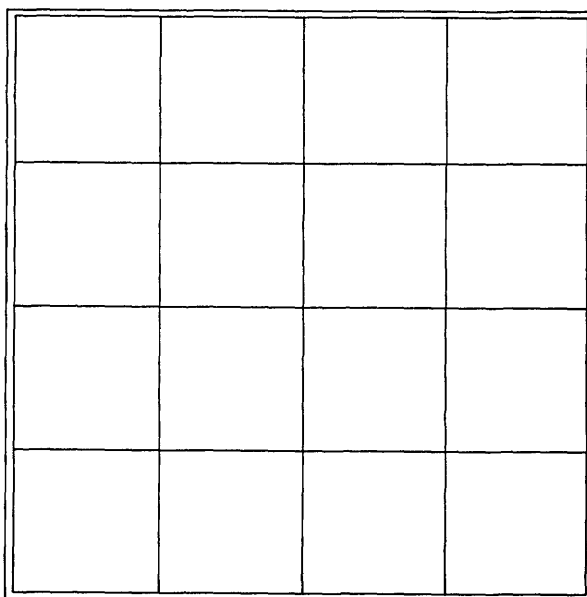

This is a game for 2 players.

You will need a supply of 8 dominoes or 8 paper rectangles.

Each player, in turn, places a domino on the square grid, so that it covers two horizontally or vertically adjacent squares.

After a domino has been placed, it cannot be moved.

The last player to be able to place a domino on the grid wins the game.

For example, this board shows the first five moves in one game:

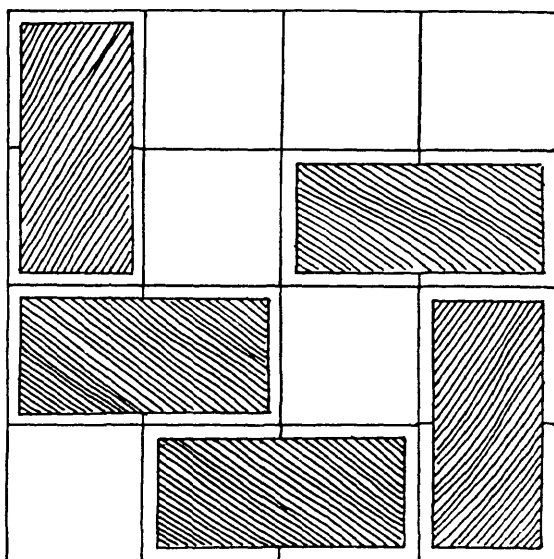

(It is player 2's turn. How can he win with his next move?)

Try to find a winning strategy.

SOLUTION TO “DOMINO SQUARE”

Player 2 can always ensure a win on a 4×4 board by placing his dominoes in such a way that the pattern of dominoes is always kept rotationally symmetrical about the centre point of the board.

For example, if player 1 puts her domino in position A, player 2 should respond by placing his at B; if player 1 puts hers at C then player 2 should put his at D etc.

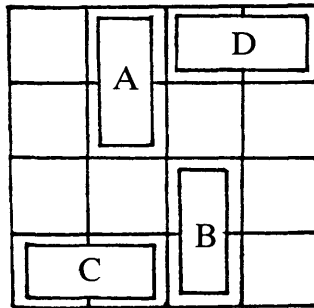

This method of play will ensure a win for player 2 on *any* board with *even* dimensions.

Possible extensions:

- * What happens when the board has *odd* dimensions?
- * Suppose the player who plays last *loses*.
- * Change the shape of the playing pieces.
- * Change the shape of the playing area.

THE TREASURE HUNT

This is a game for two players.

You will need a sheet of graph paper on which a grid has been drawn, like the one below. This grid represents a desert island.

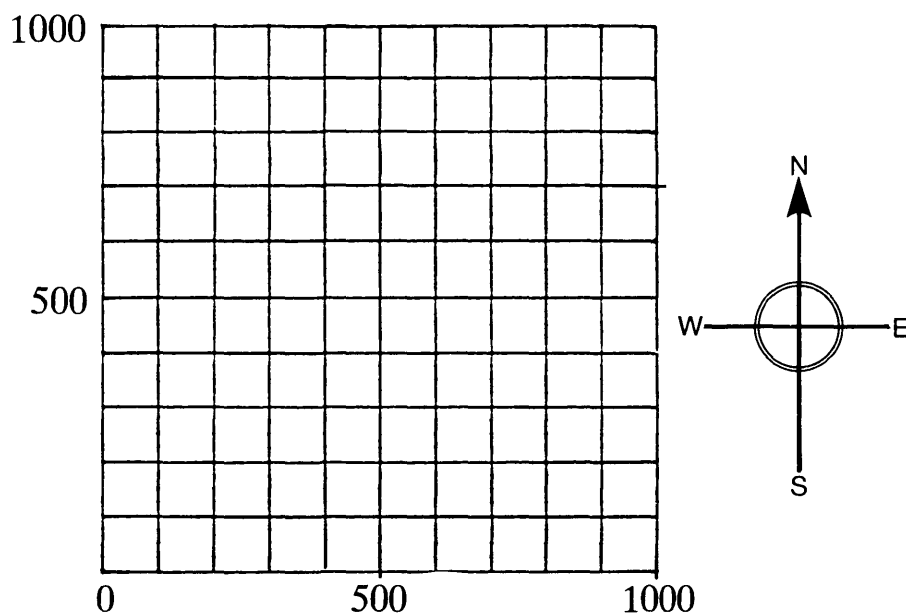

One player “buries” treasure on this island by secretly writing down a pair of coordinates which describes its position.

For example, he could bury the treasure at (810,620).

The second player must now try to discover the exact location of the treasure by “digging holes”, at various positions.

For example, she may say “I dig a hole at (200,200)”.

The first player must now try to direct her to the treasure by giving clues, which can only take the form:

“Go North”, “Go South”, “Go East”, “Go West”, or “Go South and East” etc.

In our example, the first player would say “Go North and East”.

- * Take it in turns to hide the treasure.
- * Play several games and decide who is the best “treasure hunter”.
- * How should the second player organise her “hole digging” in order to discover the treasure as quickly as possible?
- * What is the *least* number of holes that need to be dug in order to be *sure* of finding the treasure, wherever it is hidden?

SOLUTION TO THE “TREASURE HUNT”

Although there are over a million possible hiding places for the treasure, it can be located by digging a maximum of 10 holes, providing that a binary search method is used.

This method involves digging the first hole at the centre, say at (500,500).

If the first player replies, say, “Go North”, then the second player should try digging holes at (500,750) and follow this with (500,875) or (500,625) and so on, cutting down the length to be investigated by a factor of two each time. (A similar argument follows the directions “Go East”, “Go South” etc).

If the first player replies “Go North and East”, then the second player should try digging a hole at (750,750), and so on.

In order to see that only 10 moves are necessary, it is probably best to begin by considering some simple cases.

Size of grid	1×1	2×2	3×3	4×4	5×5	6×6	7×7	8×8	...
Maximum number of holes needed	2	2	3	3	3	3	4	4	...

Size of grid	7×7 to 14×14	15×15 to 30×30	31×31 to 62×62	...	511×511 to 1022×1022
Maximum number of holes needed	4	5	6	...	10

Possible extensions:

- * Change the nature of the clues. They could be given as:
 - distances along the grid lines, “You are 10 units from the treasure”.
 - warmth clues, “You are getting warmer/colder/staying at the same temperature”.
 - ...

NOTE

The computer software which accompanies this module contains a program called “PIRATES” which offers a lively and enjoyable way of introducing this situation into the classroom with children of a wide ability and age range. This program is discussed more fully in the support materials on page 144.

Support Materials

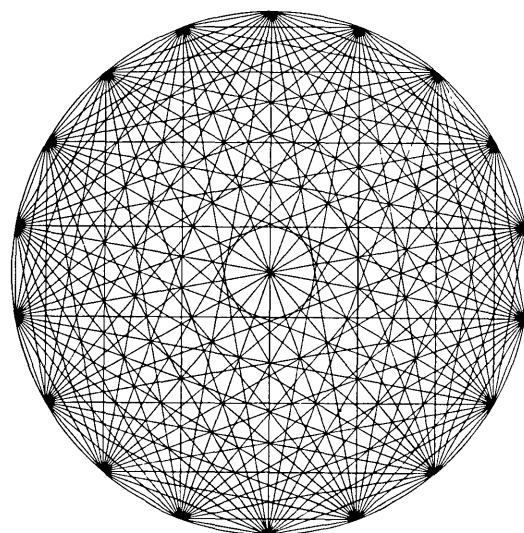

Support Materials

CONTENTS

Introduction	141
1. Looking at lessons	142
2. Experiencing problem solving	144
3. How much support do children need?	150
4. How can the micro help?	156
5. Assessing problem solving	162

INTRODUCTION

This element in the module aims to help in the following ways

- * it identifies those aspects of teaching style which help in developing children's problem solving skills.
- * it offers a straightforward supportive way for teachers to explore these possibilities in their classroom and in discussion with their colleagues.

The aim is to go beyond the teaching suggestions made in the classroom materials and also to help teachers promote a certain amount of problem solving in their classrooms beyond the immediate context of this Module.

Each of the five chapters suggest activities – some only involve the teacher in looking at the material, some suggest trying something with another class, while others require a few teachers to get together for discussion.

In the resource pack of materials are both videotape and micro-computer programs. The videotape has an accompanying booklet that uses some of the same chapter headings as this section. This will help to link the ideas and indeed you may well decide to use them in parallel. With the micro-computer programs you will again find further teaching ideas. Viewing the video or using the micro-computer programs with a small group of colleagues will be very helpful but you can also use the support materials included here, on their own.

1 LOOKING AT LESSONS

The aim of the Module is to improve the balance of classroom learning activities through stimulating more problem solving and open investigation. The classroom materials help with this.

This chapter is very much concerned with the teacher's various roles during lessons and in what ways they may differ when problem solving is the classroom focus.

It is extremely useful to observe other teachers in action, and compare their styles with your own when teaching through this Module. Most teachers who have tried it, claim to enjoy it and wish that these opportunities were less rare. However, if you want to get more than general impressions from looking at other people's teaching, it is helpful to have some structure – some simple “pegs” – to hang your observations on. They will also make you more aware of what you are doing. In order to consider a possible structure let us look at the suggested presentation of session A1 on page 47. The first lesson in Unit A uses the “Tournament” problem and aims to introduce specific strategic skills. The suggested lesson is described in seven paragraphs in the Module:

In the first paragraph of the lesson, the teacher's role mainly involves **explaining**, then in the second he **sets up the task** and offers some general suggestions to, or **counsels**, the children and discusses the problem with them, acting as a **fellow pupil**. In the third paragraph, the teacher is again the task setter, while during the fourth he counsels the children and also acts as a **resource**, providing information when asked to do so. In the fifth paragraph the teacher is required to **manage** the class as he encourages children to express their ideas in general terms. He continues to manage but also starts to explain. During the final part of the suggested presentation the teacher again acts as a fellow pupil, a counsellor and, at times, an explainer.

This description is just one possibility for lesson A1 and you may well have operated or planned to operate in quite a different way. However, you may well find it both helpful and interesting to consider what proportion of the time you were:

- explaining**
- managing**
- task setting**
- counselling**
- being a fellow pupil**
- acting as a resource.**

These 6 roles give us a crude way of looking at the teacher's activity. In this suggested presentation of A1 the 6 roles seem to be fairly evenly distributed, whereas in the vast majority of maths lessons the roles of manager, explainer and task setter appear to dominate. However, if the students are to become skilled in independent problem solving, the teacher needs to spend a larger part of the time counselling, working with them (being a fellow pupil) or just being there for consultation (acting as a resource).

Using the suggested presentation, we commented on the role of the teacher at different times during the lesson. It is equally possible to use the same headings to describe a pupil's activities and if a microcomputer program is used it is useful to note which of the 6 roles it appears to play at any time during the lesson. When a single

micro is programmed for use as a “teaching assistant” it can provide enormous support to the teacher by taking over some of the roles and leaving the teacher more scope to work with the children. This is considered further later on. If you are able to observe some mathematics lessons, use the 6 role headings and consider the balance of roles between the teacher and the pupils.

After the A1 session the children proceed through A2 and A3 where they consider different approaches to a single problem and attempt to tackle a complete problem. Unit B continues with four problems and pupils’ checklists are provided for use at the teacher’s discretion; again notes on teacher presentations are included. On page 82 the teaching notes for the Sorting problem are given. Below we give a description of this in terms of the 6 roles.

The teacher introduces the activity, handing out the sheet and counters (a task setting role) and leaves the children to consider the problem. He may suggest that the children work in pairs and encourage a competitive game situation (a managerial role). He may decide to issue the pupil’s checklist (a counselling or possibly resource role). The notes suggest a fairly supportive hint be given to those not progressing so well, i.e. “Why not generate further results from those already obtained by adding extra pairs of counters?” (counselling verging towards explaining). After allowing ample time (a general counselling role) the teacher holds a class discussion to examine the different approaches that have been used (managing and explaining, and possibly acting as a fellow pupil). The teacher then sets further explorations of the problem (task setting) encouraging them to share experiences (managing) and write up full reports of their findings. (The counsellor role is also evident during this second phase).

The video supplied with the resource pack contains several extracts from problem solving sessions with different teachers and groups of pupils. They are all using material from the Module. You will find it useful to view these sessions and to consider the different roles and activities in the various situations. The opportunity to play, replay and discuss other people’s teaching is invaluable.

Later, if the opportunity arises, you and your colleagues may find it interesting to occasionally observe each other’s lessons.

2 EXPERIENCING PROBLEM SOLVING

Many of the children will find some of the problems in the Module very demanding – everybody feels “stuck” at times when problem solving. This chapter suggests that you get one or two colleagues to join in some quite demanding problem solving in order to identify with your pupils and perhaps recognise the impact of various teaching strategies.

The microcomputer is a big help in setting up problem solving sessions with colleagues in a relaxed way. It will promote a good start to the session, and has the additional advantage that the experience often suggests ideas for good problem solving sessions with the children. However, in case you do not have immediate access to a micro, we have divided this chapter into two parts “with the micro” and “without the micro”. It is interesting to compare these. The Appendix to this chapter discusses how the microcomputer problem can be modified for use with children.

With the micro. A whole range of problems can be set up using the PIRATES† program that is provided as part of your resource pack. Here we briefly describe the program for those who have not yet explored it, suggest an easy problem to help you get the “feel” of the program (it is rather like the “Treasure Hunt” problem, page 136) and then proceed to suggest a problem that is much more demanding. Indeed a complete solution has not yet been recorded!

The PIRATES program offers you 120 different types of treasure hunt to explore. Treasure is hidden by the computer on a grid – all that you have to do is find it! It sounds simple especially as it only uses integer co-ordinates. However, in setting up the problem you are able to select from the following program features:

Program Commands	Description
[2] or [3]	Dimensions
[G]	To change the <i>Grid size</i> which can range from –1000 to 10000. etc.
[A] or [E] or [I]	Treasure hidden <i>Anywhere</i> on the current grid or hidden on certain lines or planes $x=4$ etc. (<i>Equality constraints</i>) or hidden in certain regions $y<2$ etc. (<i>Inequality constraints</i>).
[C] or [W] or [B] or [D] or [V]	Clues at each attempt are given in terms of <i>Compass directions</i> or <i>Warmth clues</i> or <i>Bearings</i> or <i>Distances</i> or <i>Vectors</i> ; the different clues promote quite different strategies.
[T] or [F]	You can have directions given “ <i>to</i> ” or “ <i>from</i> ” the treasure e.g. “go South” (to the treasure) or “you are North” (from the treasure).
[P] or [X]	Display or exclude the picture.

† The program PIRATES has been reproduced and distributed with the kind permission of ITMA/MEP/CET/Longmans. For further information and software, write to “Longman Micro Software, Burnt Mill, Harlow, Essex”.

When you actually use the program it will ask you if you would like a new problem. Respond to this by pressing the **Y** key. *Do not press **RETURN** here*, or you will get the default set of features which are **2 A C T P** with a 9 by 9 grid. This is the most simple “Treasure Hunt”. To get the other 119 you need to select your own choice of features. This you do before pressing **RETURN**.

Now for your own problem solving session we suggest the following set of options:

LOAD and RUN PIRATES

Respond to “Do you want a new problem?” with:

Y for yes. (Do not press return)

2 two dimensions

G new grid

A anywhere

W warmth clues

P display picture

RET return key

Set the grid to (0,4); (0,4)

Working together, play the game and gradually try to develop a strategy for finding the treasure in the least number of attempts. Can you generalise the result in any way?

This is a very demanding problem and you may not reach a conclusion by the end of an hour. During the session you could elect one of the group to be the teacher (the volunteer should have some warning so that they can prepare for this role). What type of help would assist you in tackling this problem? What questions could be posed to the teacher? How should the teacher answer them without “spoiling” the challenge?

Questions to think about after the session

- * How long did it take before you systematically identified the meaning of the clues?
- * Did you discuss the meaning of the response to your first guess for very long?
- * Have you noticed any useful strategies emerging?
- * Did anybody “tell” others the answers? Did you want to be told the answer at any stage?
- * What did you learn?

Without the micro. If you do not have the PIRATES program available, try the following problem together. This activity will provide you with a similar type of experience to your pupils as they face the classroom materials in the module. (A master of this “worksheet” is contained in your resource pack for photocopying). It is related to the “Treasure Hunt” problem contained in the problem collection, but is much more demanding.

A TREASURE HUNT PROBLEM

This is a game for two players.

The diagram below represents an island, and each dot represents a possible location for some buried treasure. (In this case there are 30 possible hiding places).

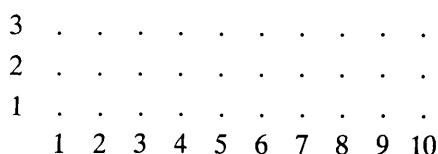

One player has to guess the location of the treasure, and the other has to provide a “clue” after each guess, which can only be of the following kind:

After the first guess, the clue is either “warm” or “cold” according to whether the treasure is located at a neighbouring point or not.

After each succeeding guess, the clue is either “warmer”, “colder”, or “same temperature”, depending on whether the guess is closer to, further away from or the same distance from the treasure as the previous guess.

The aim is to discover the treasure with as few guesses as possible.

* In the sample game shown below, the first guess, G1, was (8,3). The clue given was “cold”, so the treasure is not on any neighbouring points (shown with a ⊙).

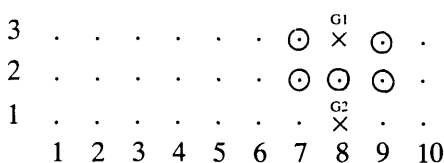

The second guess, G2, was (8,1) . . .

Show that, wherever it is buried, the treasure can always be located with a total of 5 guesses (including G1 and G2). Is this the minimum number?

- * Now try to find the minimum number of guesses needed for a different grid . . .
- * What is the best “guessing” strategy?

Questions to answer after the session

- * How did you feel? Threatened? Confident? Frustrated? . . .
- * What strategies did you adopt? Were you systematic? Did you try simple cases?
- * Did discussion help? How?
- * What help or advice would you have wanted from a “teacher” in this situation? Would you have preferred to have been left alone? How long for?
- * When would you have wanted the answers?
- * What did you learn?

Appendix

We conclude Chapter 2 with some advice on how to use the PIRATES program with children.

Example 1

If you decide to use this program say with your 13/14/15 year olds, the following selection would be a good starting point.

<input type="checkbox"/> Y	for yes a new problem
<input type="checkbox"/> 2	two dimensions
<input type="checkbox"/> G	change grid
<input type="checkbox"/> A	treasure anywhere
<input type="checkbox"/> C	compass directions
<input type="checkbox"/> F	“from” the treasure
<input type="checkbox"/> P	keep the picture displayed
<input type="checkbox"/> RET	return key
Set the grid to (0, 100); (0, 100).	

Now with the children you might try to locate where the treasure has been hidden. The clues are given in compass directions.

Some possible stages of development are:

- (i) Exploring what the clues actually mean.
- (ii) Discussing the best strategies.
- (iii) Working out the least number of “guesses” to find the treasure on any size grid.

We predict that you will notice that the program takes over part of the manager role and strongly becomes the task setter and also acts as a resource. You have the opportunity to become a fellow pupil, counsellor and to a lesser extent we hope, an explainer.

The children become very involved and are keenly interested in becoming more proficient at finding the treasure quickly. Competition becomes very keen if you divide the class into two teams.

By setting the 6 features you can raise or lower the level of demand, which means that you could use this program with any age or ability range. It was chosen for this purpose in the hope that it would be easy for you to identify a class to explore it with.

Example 2

If you wished to work with 17/18 year olds the following set of features would be appropriate:

Y for yes a new problem

3 three dimensions

G change grid

A treasure anywhere

D distance clues

RET return key

Set the grid to (0,5); (0,5); (0,5).

Here you will be considering the intersection of spheres!

3 HOW MUCH SUPPORT DO CHILDREN NEED?

In this Module pupils are gradually provided with less and less guidance as their experience of problem solving grows. This is intended to enable pupils to become more confident in their own ability to tackle problems set in unfamiliar contexts. The role of the teacher in helping to develop this independence is vital. When children are struggling with a problem, it is always a great temptation to interrupt their efforts with heavily directed hints which will produce a quick, neat solution. Such hints usually bypass difficulties, rather than overcome them and contribute nothing to a pupil's confidence or autonomy. On the other hand, unless the tasks are pitched at exactly the right level, too little guidance may result in prolonged failure and frustration. So, what kind and level of support do children need in order that they may experience the pleasure of solving (perhaps after a struggle), a problem to which they have become committed?

Textbooks and worksheets often present mathematics in a “closed”, predigested form. Often, the tasks are not problems at all, but merely lists of instructions to be followed. An introductory example is followed by a list of stereotyped questions which give little opportunity for initiative or independent enquiry. On the next page, we have listed a collection of fairly typical textbook exercises alongside more open, imaginative tasks which cover similar content. We have intentionally wandered away from “Problems with Patterns and Numbers” in order to encourage you to think about the implications of using this approach in a wider area of the syllabus. Compare the two approaches.

Perhaps you may like to think about the following questions:

- * What will the pupils *really* learn from each task?
Which “facts”, “skills”, “strategies”?
- * How long will each task take?
- * Are the tasks accessible to pupils?
Are there extensions for the more able?
Could you use these with a first year? Sixth form?
- * Which tasks would children enjoy the most? Why?
- * How would you improve the tasks?
- * Choose a worksheet or page from a textbook that you have recently been using.
Try rewriting it in a “more open” form.

A "TEXTBOOK" VERSION

If $\mathbf{a} = \begin{pmatrix} 3 \\ 1 \end{pmatrix}$, $\mathbf{b} = \begin{pmatrix} 1 \\ 2 \end{pmatrix}$, and $\mathbf{c} = \begin{pmatrix} 5 \\ -1 \end{pmatrix}$
 then write down answers to the following, and illustrate your answers with diagrams.

- 1) $\mathbf{a} + \mathbf{b}$ 2) $\mathbf{a} + 2\mathbf{c}$ 3) $2(\mathbf{a} + \mathbf{b})$
 4) $\mathbf{a} - \mathbf{b}$ 5) $4\mathbf{c} - \mathbf{b}$ 6) $3(\mathbf{a} - 2\mathbf{b})$

Show diagrammatically, that

$$\mathbf{a} + \mathbf{b} = \mathbf{b} + \mathbf{a}$$

$$2(\mathbf{a} + \mathbf{b}) = 2\mathbf{a} + 2\mathbf{b}$$

$$\mathbf{a} + (\mathbf{b} + \mathbf{c}) = (\mathbf{a} + \mathbf{b}) + \mathbf{c}$$

A MORE "OPEN" VERSION

Vectors

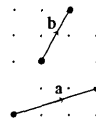

This diagram shows two vectors,
 $\mathbf{a} = \begin{pmatrix} 3 \\ 1 \end{pmatrix}$ and $\mathbf{b} = \begin{pmatrix} 1 \\ 2 \end{pmatrix}$

The point (8, 6) can be "reached" from the origin by adding the two vectors \mathbf{a} and \mathbf{b} as shown below:

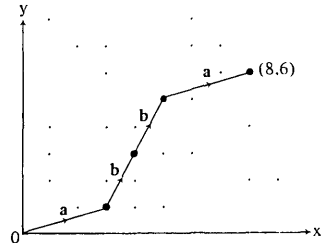

Which other points can be reached from the origin?

In how many different ways can each of these points be reached?

Suppose we allow subtraction? . . .

Algebra

Expand the following:

- 1) $x(x+2)$
 2) $(x+1)^2$
 3) $(x+1)(x-1)$
 4) $(x+2)^2 - x(x+4)$
 5) $(a+b)(a-b)$
 6) $(p+q)^2 - (p+2q)p$

Write down 3 consecutive numbers:

Square the middle number:

Multiply the other two together:

What do you notice?

e.g.: 81, 82, 83
 $82 \times 82 =$
 $81 \times 83 =$

Try other groups of 3 consecutive numbers.

What happens if you use decimals?

e.g.: 79.6, 80.6, 81.6

What happens if the numbers are not consecutive but go up in

twos? e.g.: 621, 623, 625

or threes? e.g.: 381, 384, 387

⋮ ⋮ ⋮ ⋮ ⋮

Generalise and prove your results.

Graphs and Equations

Draw the graphs of the following equations:

- 1) $y=4$ 2) $x=7$
 3) $x+y=5$ 4) $y=3x$
 5) $y=2x+3$ 6) $y=2x-7$
 7) $y=-2x+3$ 8) $y=x/2$
 9) $2x+3y=12$

Write down a simple linear equation (e.g. $3x+2y=12$) and draw its graph.

Give only the graph to your neighbour.

See if she can reconstruct the original equation.

Now make up harder examples . . .

A "TEXTBOOK" VERSION

Find the areas of these triangles:

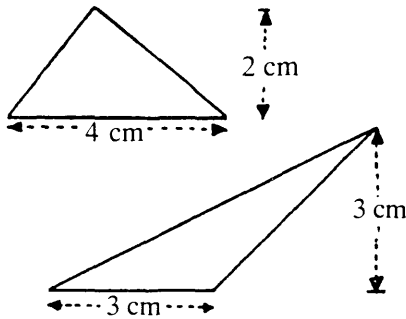

A MORE "OPEN" VERSION

Area



Find the area of this triangle, taking any measurements you consider necessary.
How accurate is your answer?
How can you check your answer, without repeating the same calculation?

An Introduction to Binary Numbers

Here is a set of five weights:

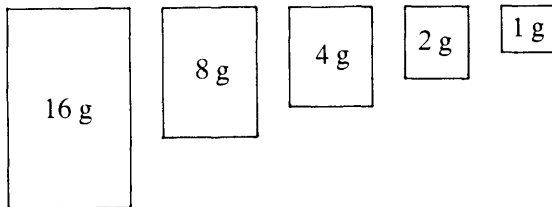

Copy and complete the table below, which shows how these weights may be used to make up every weight from 1g to 31g.

16g	8g	4g	2g	1g	Grammes
				1	1
			1	0	2
		1	1		3
	1	0	0		4

Here is a set of five numbers:

$$\{1, 3, 6, 11, 13\}$$

18 can be made by adding some of them together:

$$18 = 1 + 6 + 11$$

Can you make 20? 30? 26?

(Each number in the set may only be used once).

Which other numbers can be made?

Which other numbers cannot be made?

Which numbers can be made in more than one way?

Invent a different set of numbers which can produce every number up to the highest in only one way.

Matrices and Transformations

Draw diagrams to show the effects on the unit square, defined by (0,0), (1,0), (1,1), (0,1), of the transformations whose matrices are

- 1) $\begin{pmatrix} 1 & 0 \\ 0 & 1 \end{pmatrix}$ 2) $\begin{pmatrix} 0 & 1 \\ 1 & 0 \end{pmatrix}$ 3) $\begin{pmatrix} -1 & 0 \\ 0 & -1 \end{pmatrix}$
 4) $\begin{pmatrix} 0 & -1 \\ -1 & 0 \end{pmatrix}$ 5) $\begin{pmatrix} 1 & -1 \\ -1 & 1 \end{pmatrix}$ 6) $\begin{pmatrix} 2 & 1 \\ 1 & 2 \end{pmatrix}$

Investigate the transformations produced by the matrices in the following set:

$$\left\{ \begin{pmatrix} a & b \\ c & d \end{pmatrix} : a+b=c+d \right\}$$

(Initially, you may like to limit the values that a, b, c, d can take to 1, 0 or -1)

To continue this discussion, we look at three microcomputer programs which are included in the Resource pack with the kind permission of the ILEA and MEP/CET.* They are of interest for two reasons, firstly they provide an increasing level of support to the problem solver and secondly they are directly related to problems in the Module. They are provided as a basis for discussion with colleagues but if you decide to use them with your children you will need to consider carefully how far this might change the problem solving activities envisaged as an integral part of the Module.

The Circle Program

CIRCLE is a resource program which displays patterns made from straight lines drawn continuously inside a circle. The user specifies the number of points around the circle and the size of each jump.

After the pattern has been drawn the computer prints the number of lines and also the number of revolutions.

To investigate the various patterns children will need to record them and tabulate the numerical information. This could work with a group of mature children at the keyboard. Alternatively the program might be used for a whole class, to introduce the investigation, to explain the rules and to stimulate further work with circle worksheets. At a later stage the micro might be used again to test any rules which have been discovered.

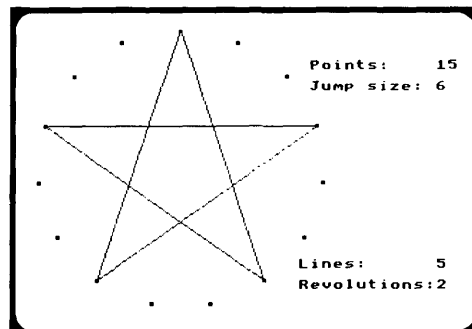

The user has chosen 15 points around the circle and a jump size of 6.

What support does the program provide? Well, it allows you to ask for any case to be shown. So it takes over the data production that is required. However, you still have to decide which cases to look at, record and organise the results and look for patterns, so it does not take over the key strategies for you. Thus, on the whole, it leaves you to do the major part of the problem solving.

It is directly relevant to the Stepping Stones problem on page 22.

If you decided to set this problem to a class you could choose various strategies for the use of the program:

- i) You could show it quite quickly at the beginning of the session to make the problem quite clear and then only come back to it later on for discussion.
- ii) You could set it up in a corner of the room and each group could have 10 minutes access to it, as they tackle the problem.
- iii) You could work through the problem with the program and the children all together, letting the children suggest inputs, record the information and suggest ways of organising and moving forward.

* The three programs CIRCLE, ROSE and TADPOLES have been reproduced and are distributed with the kind permission of the ILEA and MEP/CET. These programs form part of a total suite of some forty-one. For more details write to "Loan Services Administration, (4th Floor), Centre for Learning Resources, 275 Kennington Lane, London, SE11 5QZ.

The Rose Program

A mystic rose is made entirely from straight lines. Points are equally spaced around a circle and each pair of points is joined with a line. If the mystic rose has 15 points, how many lines are there?

In order to solve this problem, the child will almost certainly need to draw several simpler mystic roses (i.e. roses with less points).

There are two methods of approach which could be adopted. The more accessible method is an inductive one and depends on the child drawing roses with 3 points, 4 points, 5 points and so on.

Points	Lines
3	3
4	6
5	10
6	15
.	.
.	.

The program draws each new set of lines in a bright colour before they are merged with the existing lines and so the following number pattern may become evident.

Points	Lines
3	1+2
4	1+2+3
5	1+2+3+4
.	.
.	.

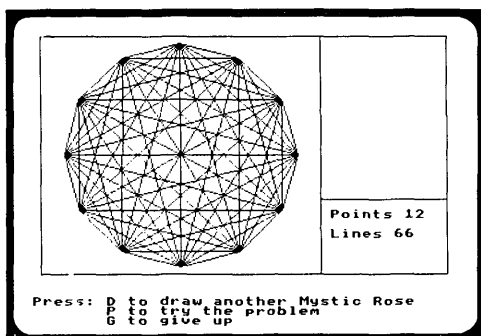

... the user has drawn a simpler rose.

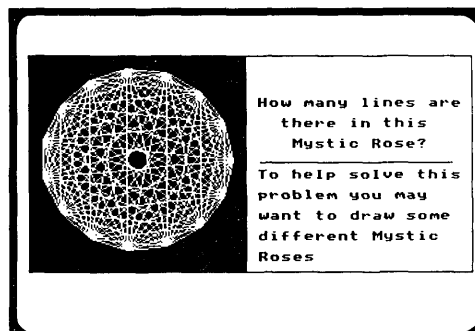

The problem is set . . .

In the example above the rose has 15 points and a child who properly understands what is happening may now be able to predict the correct number of lines. However, many children will need to follow the number pattern all the way.

The second method is analytical and so it depends on a deductive argument. The mystic rose has 15 points. Each of these is joined to the other 14. But this would imply that each line were drawn twice and so the actual number of lines must be $\frac{1}{2}(15 \times 14)$.

The program starts with a short film in which different mystic roses are drawn in a variety of ways. The film lasts for 4 minutes and the user can opt to jump straight to the problem. If the problem is answered correctly the program ends, otherwise the user has the choice of drawing her own roses, trying the problem again, or giving up.

When drawing roses the user may also change the method of drawing. Method 1 starts by drawing one line from a point to its neighbour. A third point is then joined to each of the first two. A fourth point is joined to each of the first 3 and so on. The sequence of lines is then $1+2+3+ \dots$

In method 2 the sequence is reversed. The first set of lines joins one point to each of the others. The second set of lines joins a neighbouring point to all the others (except the first point which is already joined). And so on.



Here once again the children can ask for any case to be drawn so in that respect it offers similar support to the CIRCLE program. However, you may ask for the "rose" to be drawn in two different ways and the animation on the screen and the use of colour is deliberately trying to suggest possible approaches to the problem. Also the 4 minute film sequence could well be extremely helpful in suggesting ways forward. However, for the learner to gain he will need to interpret these illustrations and thus he will be actively involved. The key strategies still need to be applied by the learner in order to reach the solution, but the exploration of simple cases, and some of the organisation of information, is closely guided and structured by the program. Spotting the pattern is obviously strongly aided. What strategies are left to the pupil?

If you decide to use the ROSE program, but wish to maintain the same development with sheet A1, we suggest you use it to highlight the discussion at the end. It links very nicely to the two solutions outlined above and in this way would strengthen the material provided. If, however, the children have already seen this program, it could change the use of the sheet A1 because the result to the Mystic Rose would already be known. You could nevertheless promote discussion on the two problems. The program raises interesting points on the power of a visual display using colour and animation to help us illustrate “reasoning” to the children.

The Tadpoles Program

There are 6 counters here.
The puzzle is to swap the counters over.



			Hops	Slides	Moves
3	3	9	6	15	
2	4	8	6	14	

A counter can slide into the empty square or jump over a counter of the opposite colour. The counters can all move in either direction and so mistakes can be corrected. This means that the activity is more accessible and may often be solved with more than the minimum number of moves.

If the puzzle has been solved in the minimum number of moves for at least one combination of counters, the user can opt to see her results.

After a number of different results have been obtained some interesting number patterns appear. . .

This program relates to the “Frogs” problem on page 114 of the Problem Collection. In contrast to the CIRCLE program this computer program takes over some crucial stages of solving the problem.

- i) It allows instant recording.
- ii) It suggests notation by labelling hops and slides.
- iii) It organises and draws up a table.

You will need to decide whether you want the pupils to do these stages themselves. As with the ROSE program, it would certainly help in discussing the problem after the pupils have had some time first to explore it by themselves.

4 HOW CAN THE MICRO HELP?

When a single micro is programmed for use as a “teaching assistant” it provides enormous support to the teacher by taking over temporarily most of the “load” of managing the learning activity of the class. The teacher then has the space to join in discussions with the pupils and to provide the more general strategic guidance that teaching problem solving demands. Research shows that teachers find this natural and easy when using such programs, and they help to “get a feel” for this kind of more open teaching. Introducing a new “personality” into the classroom (this is how the pupils perceive the micro though it is in fact entirely under teacher control) also helps to sharpen the awareness of the dynamics of the classroom and the roles that teacher, pupils and the computer can play in it.

One of the programs included in the Resource pack is a program called SNOOK*. SNOOK allows you to watch the path taken by a snooker ball on a rather special table that is divided into squares and only has 4 pockets, one at each corner. Among other things you are able to vary the height and length of the table and the gradient (G) or angle (A) of the ball.

A possible lesson with SNOOK

The reason for including this lesson for your consideration is to provide a powerful way of illustrating the key strategies (outlined on worksheet A1) while working with the whole class.

The problem is outlined on the worksheet below.

SNOOK

The snooker table illustrated has four pockets, one at each corner. A ball is placed at one corner, and is then hit away from the pocket at an angle of 45° to the sides of the table. It rebounds from each side at an angle of 45° and eventually falls into the top left hand pocket. Altogether 5 “hits” are made. (These “hits” are made up of the initial strike, the three “bounces” and the final “pot”).

How can you predict the number of “hits” that will be made by the ball, when it is struck in a similar way, on rectangular tables with other dimensions?

Which pocket will the ball fall into?

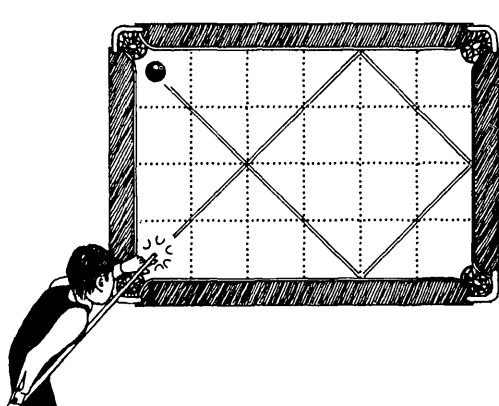

* The program SNOOK has been reproduced and distributed with the kind permission of ITMA/MEP/CET/Longmans. For further information and software, write to “Longman Micro Software, Burnt Mill, Harlow, Essex”.

Run the SNOOK program (you will need to read the documentation) and

Try some simple cases

(These results are easily obtainable by running the program or by using squared paper).

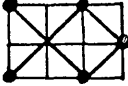
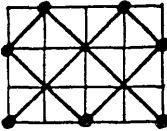
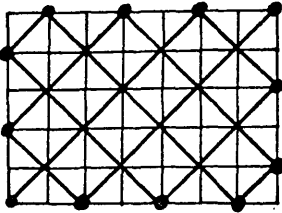
			
Size of table	2 by 3	3 by 4	5 by 7
Number of "hits"	5	7	12

Organise systematically . . . make a table . . . spot patterns

Encourage the children to make a table of their findings and make conjectures about any apparent patterns that emerge. These can then be tested on further simple cases.

		length of table						
		1	2	3	4	5	6	...
height of table	1	2	3	4	5	6	7	
	2	3	2	5	3	7	4	
	3	4	5	2	7	8	3	
	4	5	3	7	2	9	5	
	5	6	7	8	9	2	11	
	6	7	4	3	5	11	2	

For example, they may suggest that "There are always two hits on square tables", or "When the sides are m by n there are $m+n$ hits whenever m and n have no common factors . . ."

They should try testing these conjectures by putting large numbers in the computer.

"How can we be sure that our rules will always work?"

Explaining the rule

The explanation of why a rule works in this problem is difficult. (It also moves us towards the area of proof, which may well be further than you wish to go).

An outline of one possible explanation is given below.

Consider a 2 by 3 table:

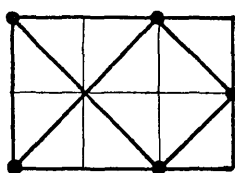

Notice that this gives us the same pattern as a 4 by 6 table:

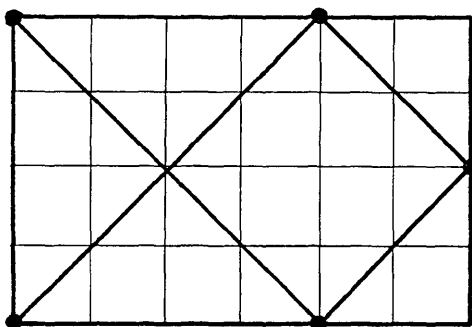

or a 6 by 8 table or, in general, a $2n$ by $3n$ table for any value of n . This must clearly be true because we are merely enlarging the diagram by a scale factor n . Arguing in reverse, we therefore see that, for example, a 180 by 200 table will give the same number of hits as a 9 by 10 table, by cancelling out the common factor 20. So, all that we now have to do is analyse the situation of an m by n table where m and n are coprime, (have no factors in common), and we will have a complete analysis.

Whenever the ball “bounces” off the side of the table, the path of the ball is reflected. Let us therefore draw a grid of 2 by 3 rectangles and attempt to “straighten” the path of the ball by a series of reflections.

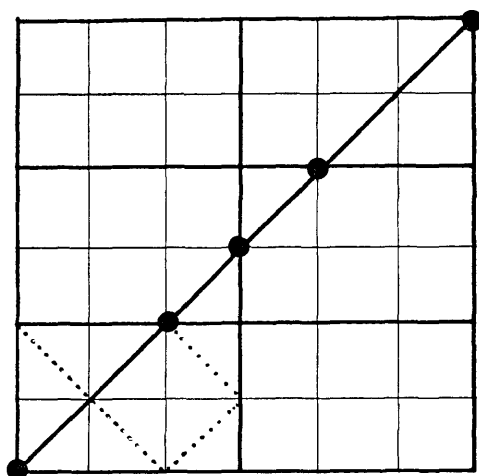

(Each “blob” (●) represents one hit)

Each time the ball passes from one rectangle to the next, a “hit” is obtained. In order for the ball to enter a pocket the grid of rectangles must form a square. Thus we can see that a total of 5 hits are required.

In general the smallest square that can be formed from m by n rectangles (where m and n are coprime) has dimensions mn by mn and is n rectangles high and m rectangles long.

The total number of hits obtained is therefore $m+n$, composed of one starting hit, $(n-1)+(m-1)$ intermediate hits, and one finishing hit.

So, in general, to decide on the number of hits on a table of any size, divide both dimensions by their common factors, and then add together the two remaining numbers.

This suggested investigation is very similar to the Diagonals problems on page 118 of the Problem Collection. You could substitute your SNOOK lesson for this problem, or you could try both with different groups and compare the two sessions.

Looking at the teacher’s role again you should find that the micro helps considerably in similar ways to those analysed earlier. SNOOK does not take over any major problem solving skills. Its main contributions to this lesson are:

- * It clearly sets the scene (explains).
- * It draws any snooker table accurately and quickly (manages).
- * It is always available to try new cases and give results (acts as a resource).

Pupils and teachers take on the counselling, explaining and fellow pupil roles and often set up further tasks that interest them.

It is of interest to compare sessions that consider this investigation both with and without the SNOOK program. “Investigator 1” January 1984* devotes considerable space to describing four groups working on the problem without a computer. It describes very fully the activities that it promoted – we can only include three brief extracts from articles written by the teachers.

* “Investigator” is a magazine produced and published by teachers through “SMILE” and details are available from The SMILE Centre, Middle Row School, Kensal Road, London W10 5DB.

1st year Mixed Ability

“What did many get out of it?

- drawing practice
- a sense of finding order in what at first seemed random
- argument and discussion
- finding rules of mappings including very hard ones with conditions such as ‘when n is a multiple of 3’
- tabulating
- expressing conclusions in their own words
- some not having met algebraic notation saw a need for it and picked it up
- making conjectures and seeing the need to test them
- the idea of starting with a simple case
- other things that I’m not yet aware of”

Below average 3rd year group

“They would not bounce the ball off the sides at 45° . They wanted to draw lines that would send the ball down in two moves, yet they did not want to draw these lines symmetrically . . . the ball seemed to have a will of its own, or rather the will of the pupil! Once some of the results of the other classes were appearing on the walls they took to the idea that the ball would travel over all the squares on every table and so they took pains to make sure that it did! The practical drawing was the main problem for this group, so a drastic rethink was necessary on my part.”

“What about my own personal experience of the week? I’ll be doing it again next year – a little older and a lot wiser with respect to the least able and a lot more hopeful with the more able groups. Maybe I’ll be able to cover two walls instead of one with the work they do next year – and it’s all interesting stuff!”

Mixed ability group

“Both the pupils and I enjoyed working on the investigation and I will continue to work in this way with the class on future occasions. All the time I was very aware of the amount of direction I was putting into the activity but would suggest that this was due in part to it being the initial investigation for the class. I hope that as the pupils’ experience grows my interjection will reduce. I want them to be able to define their own problems for investigation and to discover the usefulness of a group leader. I also want them to be able to present their own findings, but I am not sure how they should do this . . . individual accounts? . . . a group report? . . . a poster? . . . diagrams supported by tape recordings? . . .”

In conclusion, major differences between sessions with and without the “SNOOK” program appear to be:

- * With the program, children are able to move more quickly and accurately. After drawing a few examples they use the program to rapidly generate more data and build up hypotheses.
- * Able children can draw accurately and although this takes longer they are able to proceed without a micro. Less able children tend to get frustrating difficulties with drawing which can result in them not succeeding at generating valid hypotheses at all.
- * The program allows the investigation of large numbers and promotes all kinds of further investigation.
- * Less able children are very motivated by being able to use the micro and continually suggest new laws.

In general it would seem that SNOOK acts very much as a catalyst, which although not necessary, enhances the investigation.

5 ASSESSING PROBLEM SOLVING

“How can I assess problem solving activities?”

“How can progress be measured?”

These are serious questions which are often asked by teachers. After working hard on a problem for one lesson, it is difficult to produce immediate evidence of progress in the children’s knowledge and understanding of mathematics, or in their ability to deploy mathematical strategies. (The old proverb, “If you give somebody a fish you feed them for a day. If you teach them to fish you feed them for a lifetime”, highlights the dilemma. After one fishing lesson you are certainly not in a position to feed yourself, but hopefully you are progressing towards that goal.) However, it is possible to provide a few guidelines to help both the pupils and yourself. We suggest the following:

- * Encourage pupils to practice explaining their ideas clearly to each other. If they have worked together in one group, invite them to explain their approaches and discoveries to other groups.
- * Encourage individuals or groups to write out their solutions, approaches and discoveries. Explain that they will gain marks under four major headings:

- Evidence of (i) Understanding the problem
- (ii) Organising the attack on the problem
- (iii) Explaining what has been tried and what has been found
- (iv) Finding general rules, verbally or algebraically.

In the early stages of this type of work you may well award more marks to the easier items in order to encourage motivation. “Success” is an important part of “learning”. Most children find it difficult to express their ideas clearly, and even more difficult to write explanations. In order to give them a better idea of what is being asked for in the examination, you may find it helpful to refer pupils to the sample scripts and marking schemes under the section headed “Specimen Examination Questions”. In general, it is desirable that the children roughly understand how marks are awarded.

However, we should make an important point here. Marking schemes as used by the Board’s examiners have to be constructed so that they can be used reliably by many different examiners, over hundreds of scripts. This means that the schemes have to be very carefully designed for each question and it may not be obvious when looking at such a scheme that credit is given for the four general points made above. Below, we show the results obtained when a pair of teachers marked a collection of six sample scripts from children who tackled the “Skeleton Tower” question in the examination section. Instead of using the official marking scheme, they decided to give up to 5 marks for each of the four headings outlined above. These marks were awarded quickly in a fairly impressionistic manner. (No attempt was made to award a given number of marks to any particular part of a question – each solution was considered in its entirety). The overall mark (out of ten) was evaluated by summing

the four marks and dividing by two, rounding up where necessary. (The marks given in brackets were deduced directly from the official marking scheme and are shown merely for comparison.)

Scripts	Marks Awarded				
	Understanding (out of 5)	Organising (out of 5)	Explaining (out of 5)	Generalising (out of 5)	Overall Mark (out of 10)
Pupil 1	5	5	5	1	8 (8)
Pupil 2	3	2	1	0	3 (3)
Pupil 3	2	3	1	0	3 (3)
Pupil 4	5	5	2	2	7 (7)
Pupil 5	3	3	3	0	5 (6)
Pupil 6	5	5	5	4	10 (10)

The two marking schemes show remarkable agreement, although the four category method was done in a much less rigorous manner. Individual teachers may weight these categories differently (e.g.: 2:3:3:2 instead of 1:1:1:1) and interpret their meanings in different ways, but this method proves more than adequate for everyday use, and has the advantage that it emphasises important stages in problem solving. Pupils would obviously benefit more from seeing their marks under four headings than by just being given one final overall mark.

In spite of all we have said above, when marking classwork, a numerical assessment means much less to a pupil than a verbal one. Children benefit far more from a constructive comment than from a meaningless “five out of ten”. In this Module, you will find considerable emphasis at the beginning on establishing key strategies, and it pays to encourage children to use these and give credit to those who do, either in discussion or when marking classwork. The use of assessment during the formative period should be geared to encouragement, and the examination scheme should only be referred to, later, when summative assessment becomes the focus of attention.

A Marking Activity for you to try

In order to illustrate the way in which examination questions will be marked, we have supplied in the Resource Pack the scripts of six children who tackled the Skeleton Tower question. With these it is possible for you to set up a session with a few colleagues to get the feel of marking such scripts. Before you do this, however, read again through the examination section (pages 9 – 37) which gives five different examination questions, a marking scheme for each and also some annotated children’s work to help clarify various points. You may find it worthwhile to get together and follow the activity described below:

Supply yourself and three or four colleagues with copies of the marking scheme, the unmarked scripts, the marked scripts and marking record form that are provided with the Resource Pack.

MARKING RECORD FORM

Script	Marker 1				Marker 2				Marker 3				Marker 4			
	R ₀	R ₁	M ₁	M ₂	R ₀	R ₁	M ₁	M ₂	R ₀	R ₁	M ₁	M ₂	R ₀	R ₁	M ₁	M ₂
A Emma																
B Mark																
C Ian																
D Colin																
E Peter																
F Paul																

Key:

Impression rank order R₀

Raw mark M₁

Mark rank order R₁

Revised mark (if any) M₂

First read the unmarked scripts through carefully and, on the basis of your overall impression, arrange them in rank order; each teacher recording this rank order in the appropriate column R₀ on the form provided. Do not discuss them at this stage.

Now the order of the sets of scripts should be shuffled, and each teacher should mark these according to the marking scheme provided. These marks are recorded in the column M₁ on the form; work out the rank order that your marks imply and write this down in the preceding column R₁.

Now is the time to compare the various results. Looking at each script in turn, first compare your marks with those of your colleagues and try to identify the reasons for the differences. Use column M₂ to enter any revised mark in the light of your discussion. Then look at the marked script that we have provided and again try to understand the reasons for any differences. This will begin to clarify the basis on which marks are awarded.

Go back to your original rank orderings based on impression and again try to explain the reasons for any shifts of position.

In the case of examination board marking, the small discrepancies between different examiners' interpretations of the marking scheme are ironed out in discussion of a sample of scripts which every examiner has marked at a "standardising meeting". Difficult cases which remain are reviewed individually at the final stage. You may like to take your own simulation that far – the six scripts provide suitable material.

Finally, note that the six scripts used in your marking exercise (Emma, Mark, etc.) are the same six scripts referred to in the table on page 163 (Pupil 1, Pupil 2, etc.).

