

PRODUCING BEAN SEED

HANDBOOK ONE

**HANDBOOKS FOR SMALL-SCALE
BEAN SEED PRODUCERS**

This publication was developed by the
International Centre for Tropical Agriculture
(CIAT)

Written and Edited by

Soniia David

Illustrated by

Bahizi Jovan

Design and layout by

Fineline Pictures

CIAT encourages institutions and organisations to translate, reproduce or adapt this publication.

Please send information on the translation, reproduction and adaptation of this publication to:

CIAT

P.O. Box 6247, Kampala, Uganda

Fax: 256-41-567635

Email: ciat-uganda@cgiar.org

Copies of illustrations can be obtained upon request from the same address

Correct citation:

S. David. 1998. Producing bean seed: handbooks for small-scale bean producers. Handbook 1. Network on Bean Research in Africa, Occasional Publications Series, No. 29. CIAT, Kampala, Uganda

CONTENTS

| | Page Number |
|--------------------------------------|--------------------|
| Acknowledgements | v |
| Introduction | vi |
| Why is seed quality important? | 1 |
| What is good quality bean seed?..... | 2 |
| Field operations | 6 |
| Varietal selection | 7 |
| Seed selection | 7 |
| Site selection | 7 |
| Land preparation | 10 |
| Improving soil fertility | 11 |
| Planting | 13 |
| Weeding and rouging | 14 |
| Controlling insects | 15 |
| Harvesting | 17 |
| Post-harvest operations | 18 |
| Drying in pods | 18 |
| Threshing | 21 |
| Drying threshed seed | 23 |
| Winnowing and sorting | 25 |
| Measuring moisture content | 27 |
| Testing for germination | 29 |
| Treatment | 37 |
| Storage | 45 |
| Summary | 51 |

Page Number

| | |
|---|----|
| Words used by seed producers | 53 |
| Quality standards for improved and certified bean seed | 55 |
| A seed quality experiment | 56 |
| Common questions farmers ask | 62 |

Technical drawings:

| | |
|----------------------------|----|
| Parts of a bean seed | 65 |
| Threshing rack | 66 |
| Platform sorter | 67 |
| Sampling spear | 68 |
| Treatment drum | 69 |
| Silo | 70 |

Acknowledgements

Financial support for this manual comes from the Canadian International Development Agency (CIDA), the Swiss Agency for Development and Co-operation (SDC) and the United States Agency for International Development (USAID).

The technical input of several individuals and institutions are gratefully acknowledged. In particular, The Post Harvest Programme at Kawanda Agricultural Research Institute in Uganda played a major role in developing post-harvest equipment and procedures for producing bean seed. The assistance of Michael Odong, Cedric Mutyaba and Ulysses Acasio are gratefully acknowledged. Martin Wamaniala and Mark Wood of the IDEA (Initiative for the Development of Export Agriculture) Project in Kampala, Uganda provided technical advice. Anna Szakaly provided much needed assistance in re-writing the first draft and Christine Scypinski helped with editing, layout and illustration development. Charles Wortmann and Robin Buruchara gave valuable technical suggestions on agronomy and bean pathology.

INTRODUCTION TO THE HANDBOOKS FOR SMALL-SCALE BEAN SEED PRODUCERS SERIES

This handbook is intended to be used by small-scale farmers interested in producing bean seed for sale. It is written for farmers who have no formal training or experience in bean seed production. You may seek assistance in understanding some of the topics covered in this handbook from researchers, extension agents or NGOs.

This handbook on seed production is intended to be used together with two other handbooks:

1. *Controlling diseases and insect pests in bean seed fields, and,*
2. *Business skills for small-scale seed producers*

A note on technical words: Since some technical words do not exist in local languages, it will be necessary for you to develop new words in your language. In this handbook, these technical words are in English.

PRODUCING BEAN SEED

Why is Seed Quality Important ?

Most farmers know that not all the beans they harvest each season are good for planting. Damaged or broken beans may be good for eating, but are not suitable for seed. Bean seed bought from shops or markets or given as a gift by other farmers may also have been damaged by insects, or may be rotten, broken or mouldy. If damaged beans are used as seed, farmers will not get a good yield. This is why farmers usually sort out their beans and use only the **best** beans for planting

- ✓ *The **quality** of bean seed is very important because it greatly affects farmers' **yields**.*



Good quality
seed...



Will have a good
yield



Bad quality seed...

Will not grow
well

What is Good Quality Bean Seed ?

Good quality bean seed has the following properties:

- ❖ a high germination rate;
- ❖ well dried;
- ❖ pure: all seeds are of the same variety and of the same size;
- ❖ clean: is not mixed with foreign matter such as stones or dirt, or other seeds;
- ❖ not damaged, broken, shrivelled, mouldy, or insect damaged;
- ❖ not rotten (may be diseased);
- ❖ not discoloured or faded (may be diseased).

If you want to produce good quality bean seed you should make sure the seed meets these quality standards:

Quality standards for bean seed

| | |
|------------------------------|----------------|
| Germination percentage: | 80% minimum |
| Moisture | 13-15% maximum |
| Damaged seeds | 0 |
| Rotten seeds | 0 |
| Bean weevils | 0 |
| Faded (discoloured) seed | 10% |
| Foreign matter (cleanliness) | 1 |

Germination and purity

Diseased seed doesn't germinate well and produces unhealthy bean seedlings. Farmers need to know how pure their seed is in order to work out how much seed they need to plant. They can do this by carrying out a germination test. The **GERMINATION PERCENTAGE (RATE)** is measured by examining how many seeds out of the total number of seeds have germinated and are of the same variety.

Instructions for conducting a germination test are explained on page 29. To obtain the germination rate, divide the number of seeds that have germinated by the total number of seeds and multiply by 100. This gives a percentage.

For Example:

✓ *If 80 seeds out of 100 germinate, the germination rate is 80%.*

80 divide by 100 = 0.8

$$0.8 \times 100\% = 80\%$$

Good quality bean seed should be pure and clean, that is, all seed should be of the same variety and the same size. It should not include any of the following: dirt, stones, broken seed, shrivelled seed, mouldy seed, rotten seed, insect damaged seed. Only 10% of discoloured or faded (i.e. diseased) seed is allowed.

To obtain the percentage of damaged seed, divide the number of damaged seeds by the total number of seeds and multiply by 100.

For Example:

✓ *If 5 seeds out of a total of 60 seeds are damaged, then 8% are damaged.*

5 divided by 60 = 0.083

$$0.083 \times 100 = 8.3\%$$

Moisture content

Determining the moisture content of a bean seed is more difficult and requires more experience. This procedure is explained in detail on page 27. One way to test for seed moisture content is by biting the seed with your teeth or by pinching it between your fingers. The bean should be hard. If it is soft, it is too moist.



**Biting or pinching can help you test seed
moisture content**

Seed classes

Bean seed is classified into classes to show differences in quality. Quality is measured by the same criteria already mentioned; germination rate, whether the seed is pure, sufficiently dry and free from diseases. Seed produced by specialised producers for sale to farmers is called **CERTIFIED SEED**. Specialised producers might be seed projects or researchers. The instructions given in this handbook are for the production of **IMPROVED SEED**, a slightly lower class of seed than certified seed, which can be produced under farmers' conditions.

FIELD OPERATIONS

Once you have decided to start a bean seed business (see the handbook "**Establishing a Bean Seed Business**"), there are certain steps you should follow to produce good quality bean seed. This section on field operations describes what to do in the field, from selecting the site to harvesting the bean crop. The section on post-harvest operations describes what to do after harvesting, from drying the seed to storing it.

These are the steps you must follow to grow bean seed:

1. select varieties to be multiplied;
2. select seed for planting;
3. select the site where the seed will be grown;
4. prepare the land;
5. plant the seed;
6. weed and remove **ROGUE** (unwanted) plants in the field;
7. control diseases and insect pests; and harvest the seed.

VARIETAL SELECTION

The selection of the varieties that you will multiply is very important for determining the success of your business. You should only multiply varieties that you know have a market.

Selection of which varieties to multiply is discussed in the handbook "**Establishing a Bean Seed Business**". You may choose to multiply **IMPROVED** bean varieties (new varieties developed by researchers) or **LOCAL** bean varieties (farmers' traditional varieties).

SEEDS

Only plant **clean, good quality** bean seed of improved varieties obtained from a known source such as a seed project or researchers since poor quality seed will result in a poor crop. For local varieties, find a source of good quality seed in your area, for example from someone known to be a good farmer.

Because some bean diseases are "hidden" within the seed and cannot be seen with the human eye, it is important to regularly change the seed you plant. There are five major bean diseases which are "hidden" within the seed:

common bacterial blight, bean common mosaic virus, anthracnose, halo blight and ascochyta. For information on how to identify these diseases, read the handbook "**Controlling Diseases and Insect Pests in Bean Seed Fields**". If you observe that most plants in a field are affected by any of these five diseases, change your seed every 1 or 2 seasons to ensure you have a disease-free crop.

SITE SELECTION

To ensure high bean yields, select highly productive land suitable for bean production. For example, you should avoid steeply sloping land, land which is near a swamp, very sandy soil and areas with shallow surface soil and a lot of couch grass. Look for signs that indicate high soil fertility.

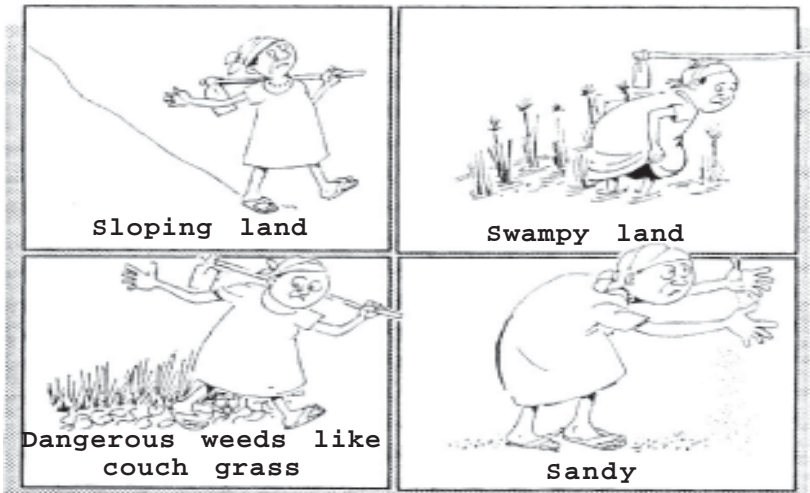

Since a number of bean diseases remain in the soil, it is important that beans for seed be grown on the same plot for **ONLY 1-2 SEASONS IN A ROW**. You will therefore need enough land allow for rotation with other crops.

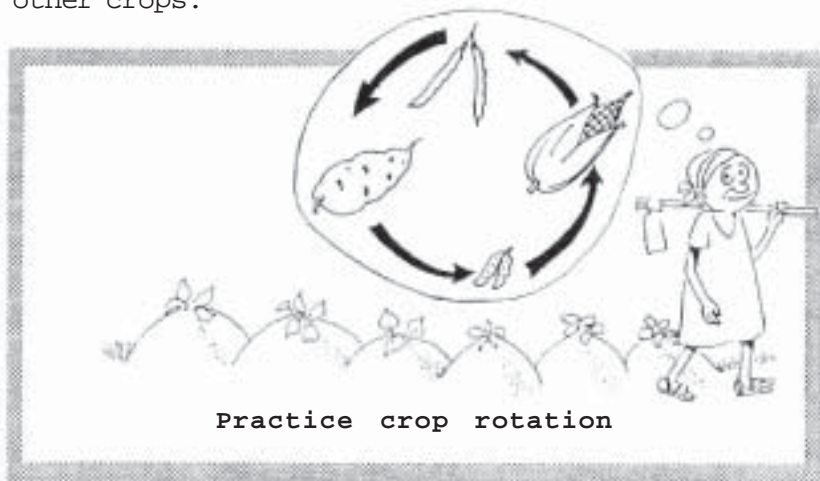

In selecting the site, also consider the distance to the place where you will store the beans. If the distance is far, you will have difficulties in transporting the harvest.

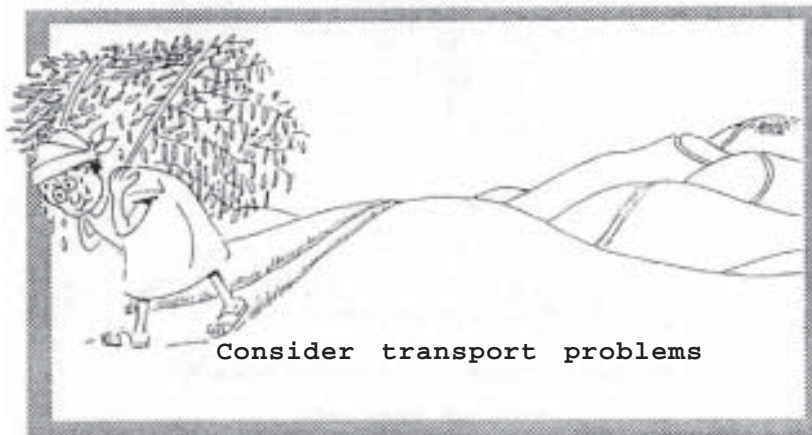

LAND PREPARATIONS

Once you have selected your site, prepare your land early. Dig or plough deeply. If there is a lot of grass or weeds in the field, you should plough at least one month before planting so that all organic material rots down. If you do not do this, the beans may emerge yellow or grow poorly.



Good land preparation (dig deeply)



Poor land preparation (shallow digging)

If possible, analyse the soil. Take samples from your field by digging at least 5 holes across each acre to a depth of 8 inches. Take a small sample of soil from each hole and mix them together. Send or take this sample to an agricultural research institute. The results will tell you if you need to use fertiliser.

IMPROVING SOIL FERTILITY

If you plan to add fertiliser, you can spread it by hand over the field before ploughing. For each acre, apply 40 kilograms of TSP plus 10 kilograms of urea (100 kilograms plus 25 kilograms per hectare). Your yields will be improved.



Fertilised field



Non-fertilised field

You can also use animal manure (especially chicken droppings) or compost to improve your soil conditions. The use of plants called **MUCUNA** and **CANAVALIA** can also increase soil productivity. You can obtain seed of Mucuna and Canavalia from an agricultural research institute. Your extension agent may also know how to obtain seed. Either plant should be planted the season before and left on the soil surface. Plant two seeds of Mucuna or Canavalia per hole at a spacing of 60 centimetres (2 feet) between plants and 75 centimetres (2.5 feet) between rows (similar to the spacing for planting maize). Since the plants grow vigorously and cover the ground quickly, it may be necessary to weed once 3 weeks after planting. When you are ready to plant a crop of bean seed, simply uproot the Mucuna or Canavalia plants and leave them to dry on the ground. There is no need to first dig the soil.

PLANTING

If you are planting certified bean seed, put only one seed in each hole. If the seed is obtained from other farmers or from shops, plant 2-3 seeds in each hole.

Plant the beans in rows. This makes it easier to weed the crop. The recommended spacing is: 50 centimetres between rows and 15-20 centimetres between plants.

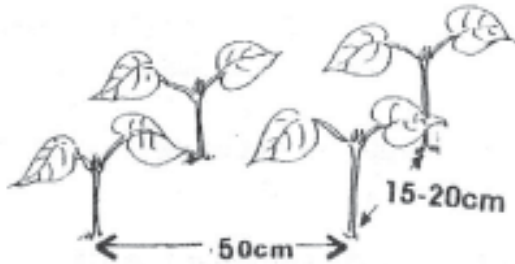

Recommended spacing between plants

When planting different bean varieties, make sure to maintain a space of 2 metres between areas where each different variety is planted to prevent mixing of varieties.

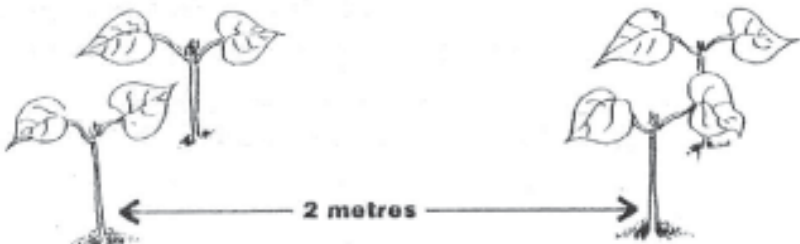

Recommended spacing between varieties

Many farmers like the idea of intercropping beans. You should not intercrop a field planted with a bean seed crop because intercropping makes the management of the crop more difficult and you are likely to harvest less.

WEEDING AND ROGUING

Weeds reduce yields. This is why it is important to weed at least 1-2 times each season. The first weeding must take place 3 weeks after planting the seed. The timing of the next weeding will depend on the weed and crop growth.

During the first 5 weeks after planting, check the field for diseased plants three (3) times:

- 1. when the plants first emerge from the soil;**
- 2. two (2) weeks later;**
- 3. when the first flowers emerge.**

Bean plants are affected by many diseases. You may not even be aware of many of these diseases. More details on how to identify bean diseases and how to inspect your field are provided in the handbook **"Controlling Diseases and Insect Pests in Bean Seed Fields"**. If only a few of the plants show signs of disease, remove them so that the disease does not spread to the healthy plants. This is called **ROGUING**. Pull out the diseased plants and burn them.

To keep the bean crop pure, you should remove plants that look very different in growth from the varieties you have planted. For example, remove plants which climb or have a different leaf shape or flower color.

CONTROLLING INSECTS

The most common insects that affect bean plants are aphids, the bean stem maggot, flower thrips, ootheca (a beetle which eats the leaves of bean plants) and different types of insects which eat pods and leaves. The handbook **"Controlling Diseases and Insect Pests in Bean Seed Fields"** teaches you how to recognise and control insects. Since insects can damage an entire crop of seed, check the field regularly for insects. Details on how to inspect your field are provided in the handbook **"Controlling Diseases and Insect Pests in Bean Seed Fields"**. Not all insects, however, cause damage to the bean plant. For example, bees will not harm your crop. Some insects such as spiders, lady birds and ants are natural enemies of harmful insects.

Chemicals

Insects can be controlled by spraying the crop with chemicals.



Alphids and Flower Thrips: Use Dimethoate (Rogor) or Sumithion against aphids and flower thrips. Use 20 millilitres (4 teaspoons) per 15 litre knapsack sprayer



Pod Eating Caterpillars: Use Ambush or Bulldock against pod eating caterpillars. Use 10 millilitres (2 teaspoons) per 15 litre knapsack sprayer.



Leaf Eaters: Do not worry too much about leaf eaters unless they are removing more than 1/3 of the total leaves. If this is the case, use the same recommendation as for pod eating caterpillars.



Bean Stem Maggot: If you have a problem with bean stem maggot, treat your seed before planting it. The method for treating seed against bean stem maggot is explained in the handbook "Controlling Diseases and Pests in Bean Seed Fields".

HARVESTING

Only harvest those plants that are ready (usually 90-120 days after planting depending on the variety grown). Seed which is harvested too early will not grow into healthy plants. When all leaves and pods of upright bush bean varieties are yellow, you know that the plants are ready for harvesting. Harvest pods of climbing and trailing beans as they mature. Do not harvest bean pods that are touching the soil as they may be infected with disease pathogens found in the soil.

Do not leave the beans to dry in the field after they are harvested as they can be affected by disease or eaten by insects and animals. Beans left in the sun too long may become too dry for threshing, and if left in the rain, will be too wet for threshing.



Harvest plants on
time



Avoid harvesting
late

POST-HARVEST OPERATIONS

These steps should be followed after harvesting:

1. drying in pods;
2. threshing;
3. drying threshed seed;
4. winnowing and sorting;
5. measuring moisture content;
6. testing for germination;
7. treatment;
8. storing.

DRYING IN PODS

Before beans can be threshed, they must be dried in the pod. If you start threshing immediately after harvesting, you will damage the seed because it is too moist to be threshed.

You should test the moisture of the seed before threshing using your teeth or pinching with your fingers and again before treatment using the salt test. The procedure for testing the moisture of seed is explained on page 27.

Do not dry beans on the ground. They can get dirty, wet, or eaten by animals if they are dried in this way. Instead, you can dry beans in their pods on a mat.



Crop drying on a mat

It is better to dry the beans on a plastic sheet, on a raised platform or in a maize crib.



Crop drying on a raised platform

Ask someone to watch the beans while they dry. This person can cover the beans if it rains and can chase away animals.



Watch over the drying pods



Once you have prepared a place to dry the beans, follow these steps:

1. Sort the seed pods and remove weeds and immature pods.



2. Arrange the pods loosely on the platform, mat, or crib. If you put them too close together, the air will not circulate and the beans will get mouldy.

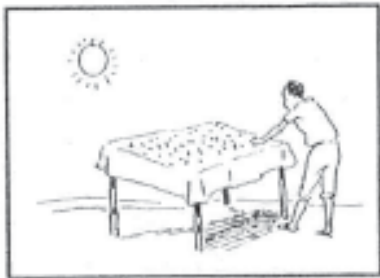

3. Dry the beans from morning to evening for 2 sunny days.



4. Test the beans to see whether they are dry enough by breaking a few pods open and biting or pinching them with your fingers.

THRESHING

When you have decided that the beans are dry enough, they can be threshed. Remember that beans that are too dry and beans that are too wet can be easily damaged during threshing.

In threshing, it is important:

1. not to break and damage the seed;
2. not to mix the seed with dirt and rubbish;
3. not to lose seed.

Threshing on the ground or in a gunny bag can easily damage the seed. Broken or cracked seed is more likely to be attacked by insects and mould and may not germinate.

Threshing on a threshing rack protects the seed from damage and dirt and prevents it from scattering.



A woman threshing on a threshing rack

A threshing rack consists of strips of wood arranged on a platform with a wire mesh tray on the bottom to catch the threshed seed. The seed is prevented from scattering during threshing by the high wooden sides.

This threshing rack can be made by a local carpenter using a design - see drawing on page 66 for details

DRYING THRESHED SEED

After the seed has been threshed, it must be dried again. As always, it is important to protect the seed from rain, insects, animals and dirt.

Threshed seed should be dried on mats, plastic sheets or wire mesh trays raised on a platform.

1. Spread the seed thinly on the drying surface to allow air to pass through it.



2. Turn the seed regularly to avoid overheating.



3. Dry the seed for 1-3 sunny days.

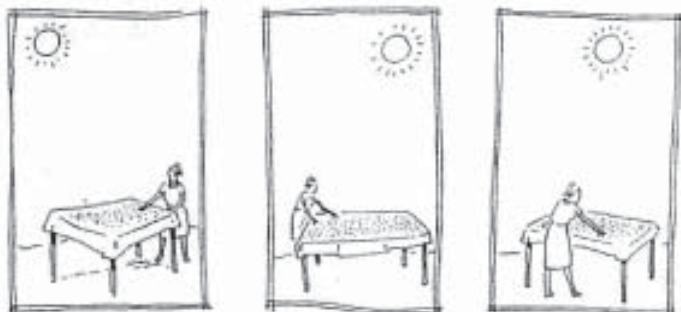

4. Take care to avoid the seed getting wet by rain or being damaged by domestic animals.



5. Test the beans to see whether they are dry enough by biting or pinching them with your fingers.



WINNOWING AND SORTING

Winnowing should be done to remove chaff, dust and other rubbish from the seed.



A man winnowing

After winnowing, remove shrivelled, diseased, broken seed and seed of other varieties by sorting. Sorting on a platform sorter makes the work easier because no bending is required and the wire meshing gets rid of some of the dirt mixed with the seed. A platform sorter consists of two wooden funnels with wire mesh trays to catch the seed. The sorter is placed on a table and people can sort while seated at the table.



Using a platform sorter

To use the platform sorter, pour dried seed that has been winnowed down the funnels. The seed falls on the wire mesh screen and can then be sorted by hand. The wire mesh traps small broken seed and allows dirt and rubbish to be removed easily. Different sizes of wire mesh can be used for varieties of different seed sizes.

A local carpenter can make a platform sorter using the design on page 67

MEASURING MOISTURE CONTENT

The salt test is a good way to determine the moisture of threshed seed:

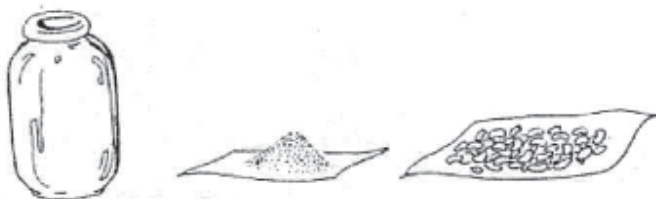

For this test you will need a clean, dry jar with a lid, some salt and a sample of bean seed.



Take one sample (a handful is enough) from the middle of each bag of bean seed. It is best to remove a sample using a special instrument called a sampling spear (see page 67 for details on how to make it). Treat each sample separately.



Steps for the Salt Test

1. Make sure that the jar you are using is clean and completely dry.



2. Put the salt in the jar (enough salt to fill up a quarter of the jar) and add a sample of seed (enough to fill half of the jar). Put the lid on the jar.



3. Shake the jar well and then allow the seed to settle for about 10 minutes.

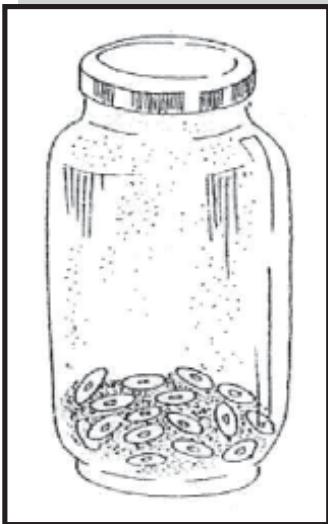

4. If after 10 minutes you can see damp salt stuck to the sides of the jar, the seed is too moist. This means that the amount of moisture in the seed is above the 13-15% required for improved bean seed. If the jar is dry and there is no salt stuck to the sides of the jar, the seed is dry.

TESTING FOR GERMINATION

After cleaning and sorting, a sample of seed should be tested for germination.

The results of the test will tell farmers how much seed they need to plant to get good yields. For example, if you know that 90% of your seed will germinate (i.e. it has a 90% germination rate), you can work out how much seed to plant, taking into consideration. If you have seed with a 60% germination rate, you will need to plant more seed than that with a 90% germination rate.

Seed should be tested for germination before it is stored. If seed has been stored for more than five months another germination test should be performed before it is sold.

Steps for the Germination Test



Step 1. Obtain a sample for testing

a) Wash your hands. Take samples of seeds (a handful is enough) from the top, middle and bottom of **each** bag produced using a sampling spear.



b) In a plastic bowl or basin, mix all of the three samples from the bag together.



c) Remove a one kilogram seed sample from the bowl and mix it again in another bowl.



d) Pour seed on a clean wooden table and count out the first 200 seeds that you see. Do not pick out particular seeds deliberately; count all 200 seeds from one end of the pile. Put the remaining seed back into the bags.

Step 2. Plant the seeds

Wash your hands. Separate the sample of 200 seeds, into 2 equal groups (batches) of 100 seeds each. Plant each batch of 100 seeds into two separate containers using the following instructions. You can also use more containers and smaller samples (25 or 50 seeds per container), if don't have large containers to fit 100 seeds.

It is better to use sand as a planting medium, but if you do not have sand, you can use soil. Put clean, moist sand or soil at a depth of 10-12 centimetres loosely into each container. Make small planting holes 2-3 centimeters apart in rows with a small stick. Plant 1 bean seed per hole.

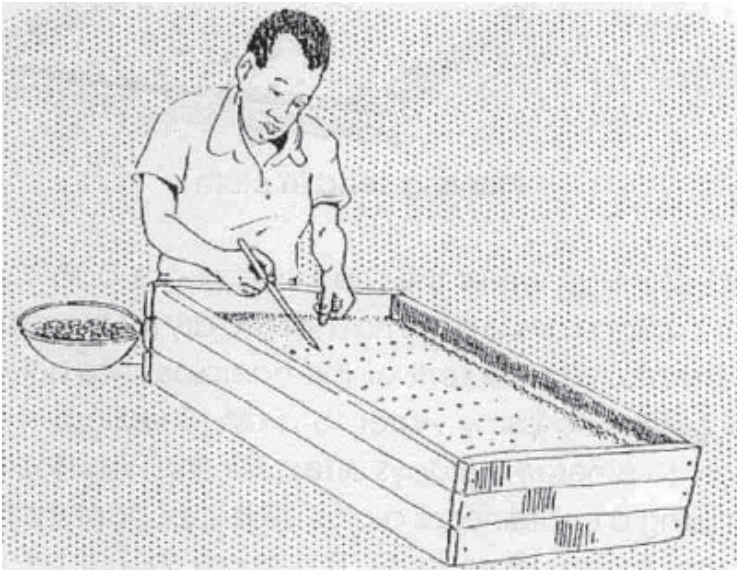

Planting seed in soil

Cloth, paper towels or newspaper can also be used instead of sand or soil. Moisten the cloth, paper towel or newspaper in water and place the seeds on it (each seed should be spaced 2-3cm apart). Cover the seeds with another piece of moist cloth, paper towel or newspaper.



Planting seed on moist cloth, paper towels or newspaper

The containers should be kept indoors for the next two weeks to allow time for the seeds to germinate. It is important that you control the moisture level during this time. The seeds should be kept moist, but not wet. Both too much or too little water can prevent seed germination. After planting, water the seed and check daily to ensure that the sand or soil does not get too dry. Make sure that the container has holes on the bottom to allow water to drain. Seedlings should begin to emerge 7-11 days after planting.

Step 3. Observe the seedlings

Eight (8) days after planting, carefully dig the seedlings up from the sand/soil or observe the seedlings growing on the cloth, paper towel or newspaper and categorise them into three groups:

a. Normal seedlings:

These will have :
well-developed
roots, stems, leaves, &
cotyledons (food storing areas
of the seed- see picture below)

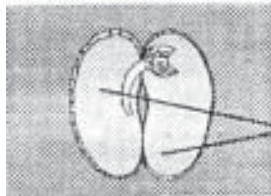

Cotyledons

b. Abnormal seedlings:

These will have any of the following signs:
no main root
weak roots
no leaves
weak leaves
no cotyledons
decayed cotyledons

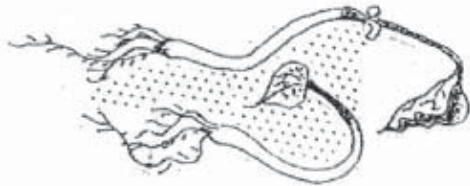

c. Rotten, diseased and unviable seeds

Has not germinated
May have outgrowths
(blue, grey,
green, black in colour)



Step 4. Record your results Fill in this type of chart to help you record your observations:

| | Total Seeds | Normal Seedlings | Abnormal Seedlings | R/D/U Seeds |
|---------|-------------|------------------|--------------------|-------------|
| Batch 1 | 100 | | | |
| Batch 2 | 100 | | | |
| Total | 100 | | | |

Step 5. Calculate the germination percentage

(a). First calculate the germination percentage for each batch separately:

i. Count the number of normal seedlings

ii. Divide this number by the number of seeds that you planted (100 in this case)

iii. Multiply this number by 100.

(b) Next, calculate the average germination rate for all batches:

i. Add the percentage for each batch.

ii. Divide this number by the number of batches. (In this case there are 2 batches)

Example:

In this example, the germination test has been conducted with 100 seeds planted in two batches.

| | Total Seeds | Normal Seedlings | Abnormal Seedlings | R/D/U Seeds |
|---------|-------------|------------------|--------------------|-------------|
| Batch 1 | 100 | 82 | 12 | 6 |
| Batch 2 | 100 | 86 | 9 | 5 |
| Total | 200 | 168 | 21 | 11 |

Since the total seeds in each batch is 100:

Batch 1 - has a germination percentage of 82%

Batch 2 - has a germination percentage of 86%

Add the percentages:

$$82 + 86 = 168$$

Divide this figure by the number of batches to get an average germinate rate:

$$168 \div 2 = 84$$

In this example, the overall germination percentage is 84%. This means that 84 seeds out of 100 seeds are normal seeds which grew into healthy seedlings.

Note:

Seed that germinates to give a germination rate of below 80% should not be sold as seed but can be used or sold as food grain

TREATMENT

The purpose of treating bean seed is to protect it from damage by insects, rats and mould when stored for long periods of time.



Weevil damaged seed

Seed can also be treated to protect the crop against diseases and field insects such as bean stem maggot. Read the handbook **"Controlling Diseases and Insect Pests in Bean Seed Fields"** for more details on seed treatment for bean stem maggot.

Traditional treatments against damage during storage

These include: frequent drying in the sun, coating with banana juice or mixing with ash, termite soil, hot pepper or eucalyptus leaves.

Treatment with chemicals

Chemicals can be more effective than traditional methods. However, chemicals are poisonous, and great care must be taken when using them.

Important

Use insecticides only after you have been trained.

Strictly follow the instructions on the container of the chemicals.

Insecticides lose their strength over time. If they have been on the shelf for a long time before you buy them, they may not be effective.

Never eat seed that has been treated with chemicals - even if it has been stored for a long time after treatment.



Recommended chemicals for treating bean seed are Actellic and Malathion. For 100 kilograms of seed, 200 grams of insecticide should be used on average. Read the instructions that come with the chemical to find the right dosage to use.

A normal match box container, level-filled with chemical holds about 25 grams. For example, to treat 100 kilograms of seed with 200 grams of chemical, you should measure out 8 match boxes of the chemical.

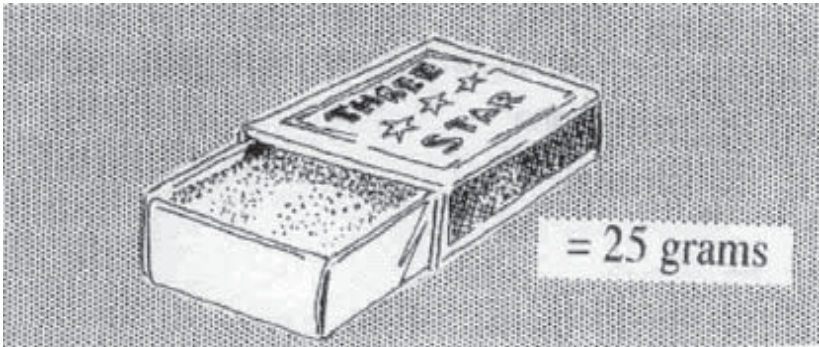

A match box

Applying seed treatment chemicals with a shovel

Warning !

Be aware that when applying treatment chemicals with a shovel or container, you are likely to inhale the chemicals which may be dangerous to your health.



Chemicals are poisonous. You must use them only in a well ventilated place. Do not smoke, eat or drink while the work is being done.

1. Empty the seed onto a clean concrete floor or a clean polythene sheet that is kept only for this purpose.



2. Sprinkle the recommended amount of insecticide evenly over the seed.



3. Using a clean shovel, hoe, large bowl or a cut-off 20 litre tin, gently mix the chemical into the heap of seeds until all of the seeds are evenly coated. When you are finished, you should not be able to see any



4. Put the treated seed in a bag and store it in a clean, dry place.



5. Wash your hands very well after you have finished. Seed needs to be retreated after it has been stored for 3 months. Use the same amount of chemicals that was first applied and follow the procedure outlined above.



Wash your hands after applying chemicals

Applying chemicals using a treatment drum

A treatment drum is a simple metal drum supported on a frame. Treating seed in a treatment drum is better than treating by hand as it allows the chemicals to be spread more evenly over the seed. It also avoids the health problems from people inhaling dust from the chemicals.

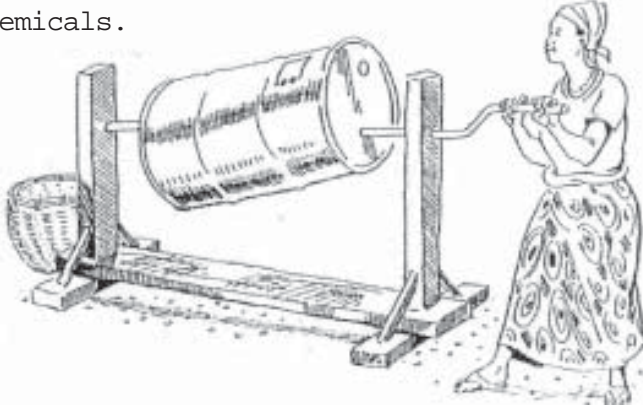

Using a treatment drum

Using a treatment drum

1. Before you use the drum, make sure that it is clean and in good condition. Use a broom to clean the inside, but never use a damp cloth because this may make the drum rusty. Inspect the drum for loose bolts and tighten them up.
2. Pour half the seed to be treated into the drum. Next, sprinkle the correct amount of chemical onto the seed. Then pour the remaining seed inside.

3. Seal the small door by tightening the bolts with a spanner. If there is space between the door and the body of the drum, cover the opening with a piece of cloth before bolting the door.
4. Turn the drum 15 times while standing in an upright position. Wait for 5 minutes for the dust to settle before opening the door. Chemicals are poisonous, so do not inhale the dust.
5. Spread a large plastic sheet or container below the door to collect the treated seed. Swing the drum from side to side to make sure that all the seed has been removed. If there are a few seeds left in the drum, you can remove them with a broom.

The treatment drum shown on page 68 has a capacity of 100 kilograms of seed. You will need a size 13 spanner to open and close the door of the drum.

A local welder can make a treatment drum by using the design on page 69

STORAGE

Store your seed carefully to avoid damaging it. Make sure that you keep your seed **clean** and **dry**.

Seed must be dry before it is packaged and stored. Proper drying reduces the chance of mould. The moisture content should not be greater than 13-15%. If salt sticks to the jar when you do the salt test for moisture (see page 27 for details), dry the seed again before you store it.

Make sure that any container used to store the seed (including bags or sacks) is clean and disinfected. Wash containers and then disinfect them by boiling them in



**Disinfect sacks and containers by
boiling them in water for 5 minutes**

If you are disinfecting a polythene sack, make sure that it does not touch the outside of the pot. The heat may damage it. All sacks and containers must be completely dry before you use them to store seeds.



dry sacks well

Once you have put the beans in sacks or other containers, they should be stored in a clean, dry and well ventilated place. Make sure that the storage place you use has no leaks. Rain water should not run down the walls of the storage place.



Close holes where rodents can come in



Do not let rain leak into the storage place



Rats and mice

Close all holes and openings where rats, insects and water can get in. Fill in cracks in the walls, floor and ceiling. Keep the storage area very clean to discourage rats and mice. These animals like to eat and hide in rubbish, so you should remove any rubbish from the storage area.



Remove all rubbish

Cut the grass around the storage area as rats do not like to cross open spaces, If you have a storage structure on poles, build rat guards to keep rats from climbing them.

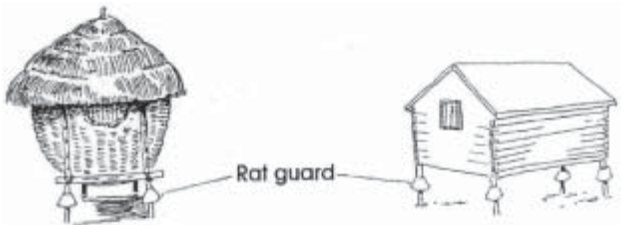

You can make a rat guard from a piece of tin or a flattened tin can. Bend it to form a cone with a hole in the centre. Fasten it around the legs of the poles with nails or wire.



You can make a rat guard

Kill rats and mice with traps and rat poison. Be careful if you are using poison. Never mix rat poison with the seed. Burn all dead rats and mice.

Protect the seed from moisture by keeping it off the ground and away from the walls. Sacks should be at least 1 metre (3 feet) away from the walls, and should be placed on a platform of sticks.

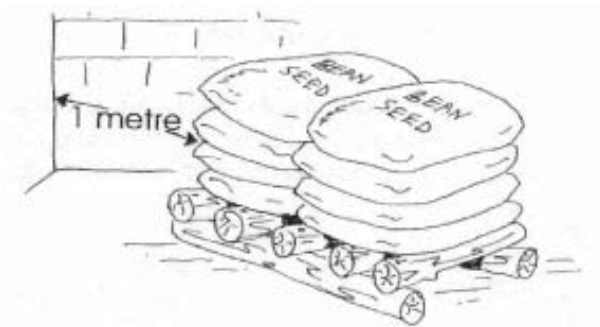

Sacks on a platform of sticks

Never store newly harvested bean seed with old seed. If the older seed is infected with insects, they will spread to the new seed as well.

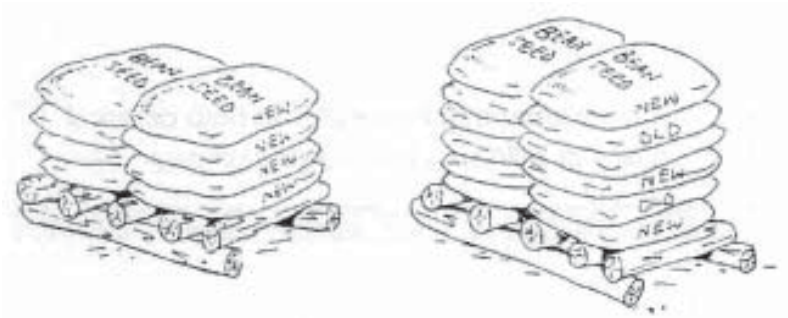

Right

Wrong

Seed can also be stored in a large metal bin (called a silo). Silos can be made in different sizes, depending on your level of production.



Farmer pouring seed into silo

Since the silo is made of metal, the seed is well protected against insects and moisture. The seed can easily be poured into the silo and emptied out when needed.

A local welder can make silos to hold different amounts using the design on page 70

SUMMARY

There are certain steps to follow to produce good quality bean seed.



1. Be convinced of the advantages of good quality seed: It has a high germination rate, is well dried, is pure, clean, free of diseases and undamaged.



2. Ensure the quality of your seed crop by planting clean, varietally pure seed. Seed should be changed every 1-2 seasons because of possible "hidden" disease within the seed which can affect plants. Get fresh seed from a reliable source.



3. Do not plant in a field where beans were planted in the previous season (to prevent varietal mixing). Select a fertile site and manage the crop well. Use fertiliser, animal manure or plants such as mucuna or canavalia to increase yields and profits from selling seed. Weed the crop as often as necessary to improve yield. For uprights bush bean varieties, harvest the crop when leaves and pods are yellow.

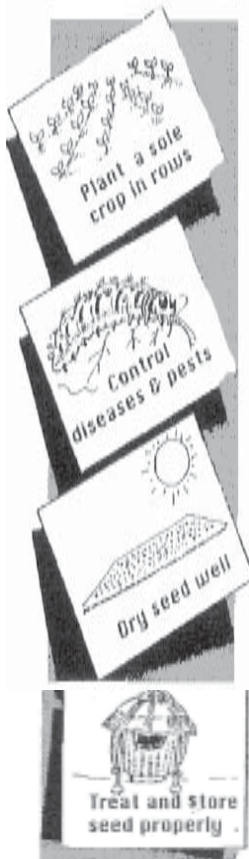

4. Use a well-prepared seed bed. Plant the bean crop in rows (easier to weed) using proper spacing (better production per plant). Weed three times.

5. Control diseases and pests: remove diseased plants from the field and use chemicals to control the diseases and pests that may affect your seed crop.

6. Harvest on time. Dry the seed well and thresh without damaging it. When drying, protect the seed from moisture and dirt. Test the seed for moisture content and for germination rate.

7. Treat and store the seed properly: treat the seed with chemicals to preserve it against insect damage in the field and when stored. Store it in a clean, dry place.

Once you master these steps you can plant your first crop of bean seed. With experience, your techniques will improve. Don't forget to read the other two handbooks **"Controlling Diseases and Insect Pests in Bean Seed Fields"** and **"Establishing a Bean Seed Business"**.

WORDS USED BY SEED PRODUCERS

| WORD | THE WORD MEANS | MORE ON PAGE |
|-------------------------------|--|-----------------|
| BEAN SEED | Beans produced specially for planting rather than eating. | 1 - 3 |
| CERTIFIED SEED | Carefully produced seed of high quality which meets certain requirements. | 5 |
| IMPROVED BEAN VARIETIES | Bean varieties that have been developed by researchers. These varieties have higher yields and are usually more resistant to diseases and pests than farmers' varieties. | 7 |
| IMPROVED SEED | Carefully produced seed of high quality which meets quality requirements that are slightly lower than certified seed. | 5, 55 |
| LOCAL BEAN VARIETIES | Bean varieties that farmers grow traditionally. | 7 |
| GERMINATION PERCENTAGE (RATE) | The number of seeds expected to germinate out of 100 seeds planted. | 3, 4 29 - 36 |

| WORD | THE WORD MEANS | MORE ON PAGE |
|--------------------------|---|--------------|
| MUCUNA AND CANAVALLIA | Plants which can be grown on crop land and then incorporated into the soil to improve soil fertility | 12 |
| ROGUING | To remove unwanted plants from a field. Plants may be unwanted because they are diseased or of a different variety than the other plants. | 14 |

QUALITY PARAMETERS FOR IMPROVED AND CERTIFIED BEAN SEED

| | IMPROVED SEED | CERTIFIED SEED |
|-------------------------------------|---|----------------|
| Isolation (meters) | 2 | 5 |
| Purity (by weight) | 90% | 99% |
| Germination(minimum) | 80% | 80% |
| Disease level (at final inspection) | Halo blight, Common bacterial blight, Anthracnose: signs on leaves only Bean common mosaic virus: none | None |
| Moisture | 13% | 13% |
| Varietal purity | N.A. | 99% |
| Off-types (maximum) | 10/10,000 | 10/10,000 |

A SEED QUALITY EXPERIMENT

To see the difference between seed of different quality, try the following experiment.

1. Take small samples (50-100 seeds) of 4 types of bean seed of the same variety:



- (i) **sort seed** using your usual method of sorting;



- (ii) **Seed that you do not sort at all;**

(iii) **"Bad" seed** that you rejected when sorting and;



(iv) **Clean seed**: seed that you get from researchers, a seed project, or seed that you have produced using the methods described in this handbook.



2. Select an area with good soil fertility where beans have not been grown for 1 or more seasons.



3. Plant the 4 types of seed separately in different rows or blocks. For example, sorted seed may be planted in the first 2 rows, unsorted seed in the next two rows "bad" seed in the next two rows and "clean" seed in the next two rows. Do not forget to mark each row indicating the type of seed planted. Make sure to plant all 4 types of seed on the same day and record the date of planting.



4. Observe the plants at different stages of growth:

- i. 3-5 days after planting to check for germination;
- ii. when the leaves emerge;
- iii. at flowering, and;
- iv. just before harvesting.

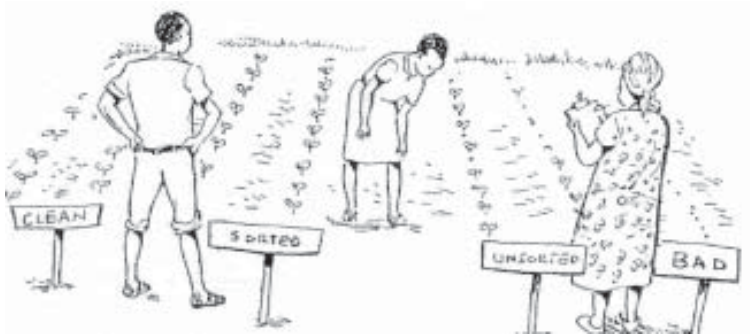

5. To help note observations, answer these questions for each type of seed:

1. Germination:

- a) How many days after planting did the seeds germinate?
- b) How many seeds did you plant?
- c) How many germinated?

| Clean | Sorted | Unsorted | Bad |
|-------|--------|----------|-----|
| | | | |
| | | | |
| | | | |

2. Grow:

- a) How many days after planting did the leaves appear?
- b) How many days after planting did the flowers appear?

| Clean | Sorted | Unsorted | Bad |
|-------|--------|----------|-----|
| | | | |
| | | | |
| | | | |
| | | | |

3. Disease:

- a) Are any of the plants sick (*diseased*)?
- b) If *yes*, *how many*?
- c) What does the sickness look like?

| Clean | Sorted | Unsorted | Bad |
|-------|--------|----------|-----|
| | | | |
| | | | |
| | | | |
| | | | |

4. Yield:

- a) How many beans were produced?
- b) How many beans are good quality?

| Clean | Sorted | Unsorted | |
|-------|--------|----------|--|
| Bad | | | |
| | | | |
| | | | |
| | | | |
| | | | |

5. Compare germination, growth and signs of disease:

Which seeds performed the best?

| Clean | Sorted | Unsorted | |
|-------|--------|----------|--|
| Bad | | | |
| | | | |
| | | | |
| | | | |
| | | | |

COMMON QUESTIONS FARMERS ASK

QUESTION:

If I continue planting beans on the same piece of land for over 2 seasons, what will happen?

ANSWER:

Your yields will decline, the crop is likely to be diseased and the roots may be affected by worms.

QUESTION:

I would prefer to intercrop my seed crop. Why can't I do this?

ANSWER:

You will have to decide whether your business can afford to have reduced yields. Remember, you are producing bean seed for a business and therefore you want to increase yields so as to make more money.

QUESTION:

Can I also plant climbing beans as a seed crop?

ANSWER:

Yes, if you think there is demand in your area of climbing beans. Follow all steps outlined in the manual. You should harvest climbing bean pods as they mature.

QUESTION:

Do I have to use all the equipment mentioned in this manual?

ANSWER :

The equipment mentioned in this manual was designed to make seed production easier and to ensure production of good quality seed. It is therefore strongly recommended that you use the equipment. All equipment can be made by local craftsmen.

QUESTION :

From my experience, boiling polythene bags causes them to break up after some time. What should I do?

ANSWER :

This may be true but even without boiling, over time polythene bags will break up. Although it is recommended that you boil your bags to kill insects, you will have to make the best decision for your situation.

QUESTION :

Is there likely to be moisture in the silo?

ANSWER :

No, unless the silo is not well raised above the ground and if the seed in it is not well dried.

QUESTION :

The manual states that you should never eat seed that has been treated with chemicals even if it has been stored for a long time. I don't want to throw that seed away. What should I do?

ANSWER :

It is very important not to eat treated seed to avoid illness from the chemicals. You could do one of two things: sell the seed for a lower price to get rid of it quickly or keep it in storage until you can sell it, re-treating it every 3 months.

If you take a long time to sell seed of a particular variety, this is a sign that you need to do better market research or plan better. Slow sales means that there is little demand for a particular variety or that the price is too high. You may have to reduce your price, your level of production or stop growing the variety in question.

PARTS OF A BEAN SEED

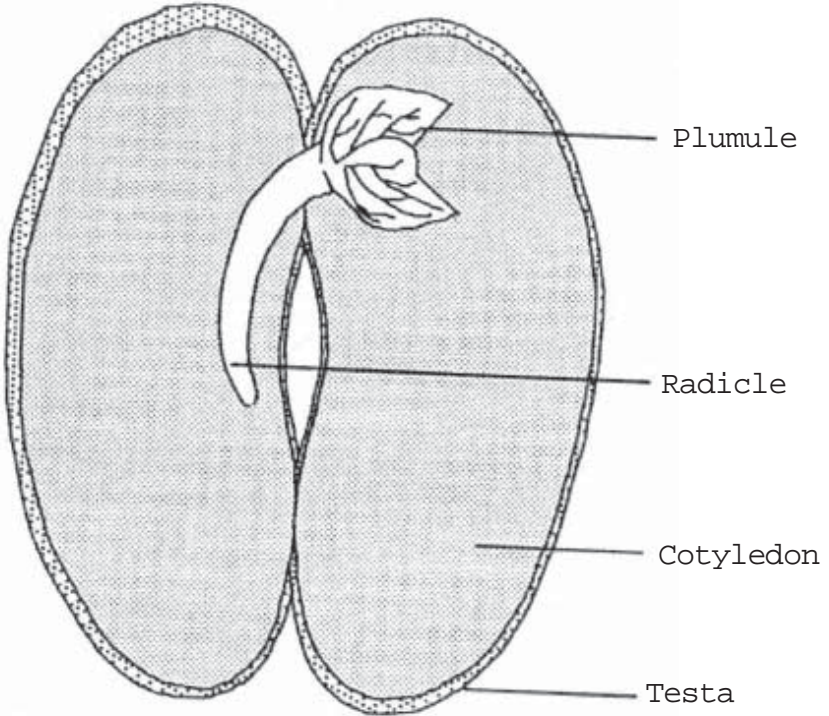

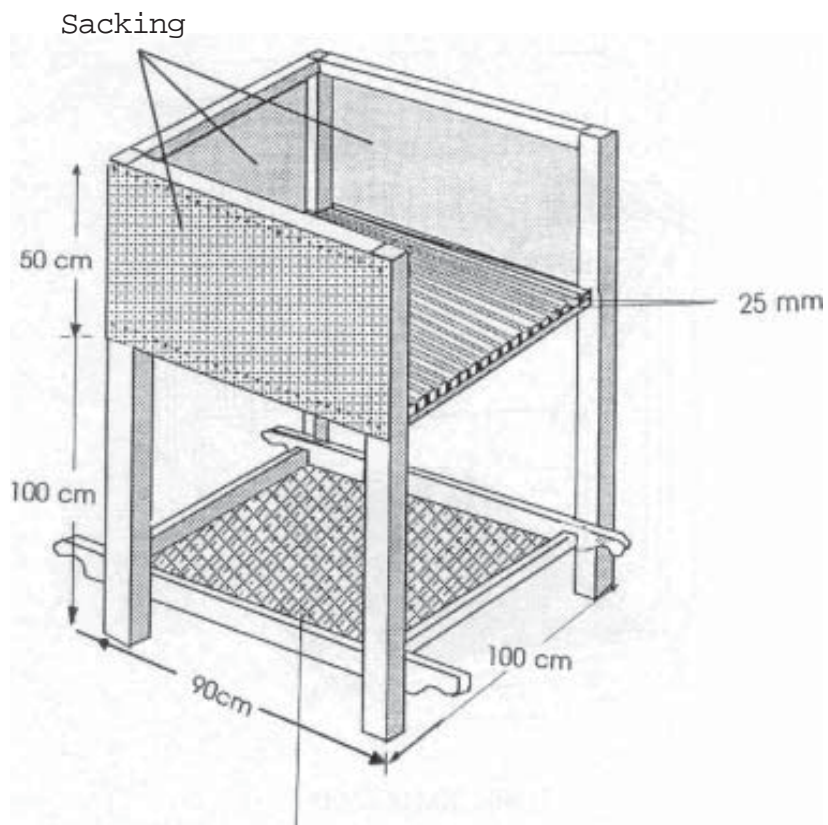

THRESHING RACK

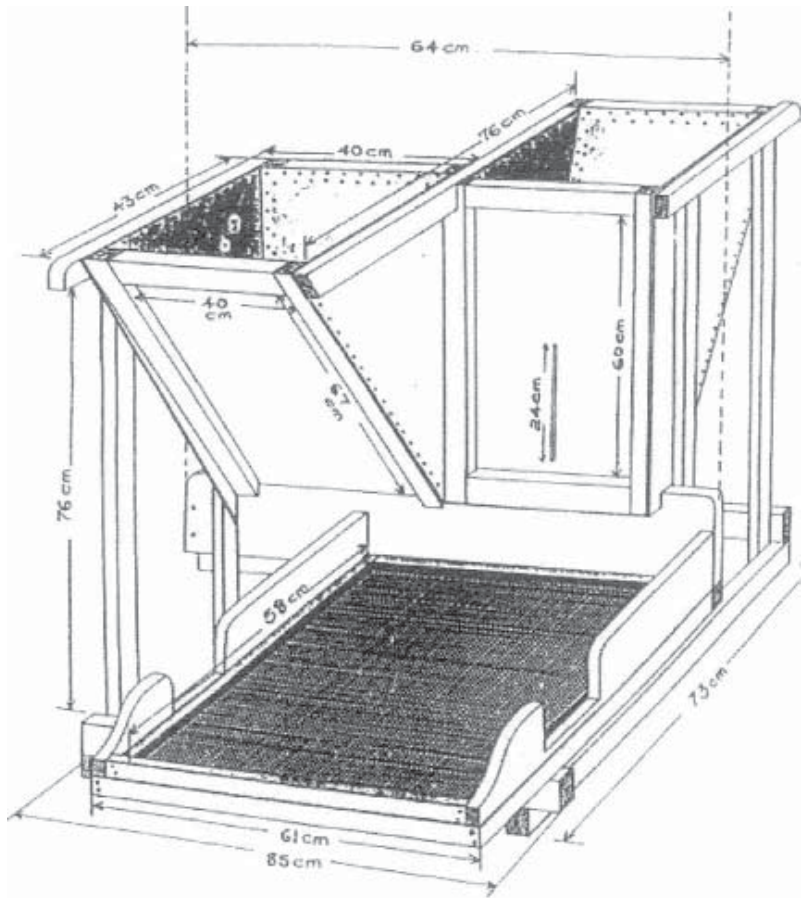

PLATFORM SORTER

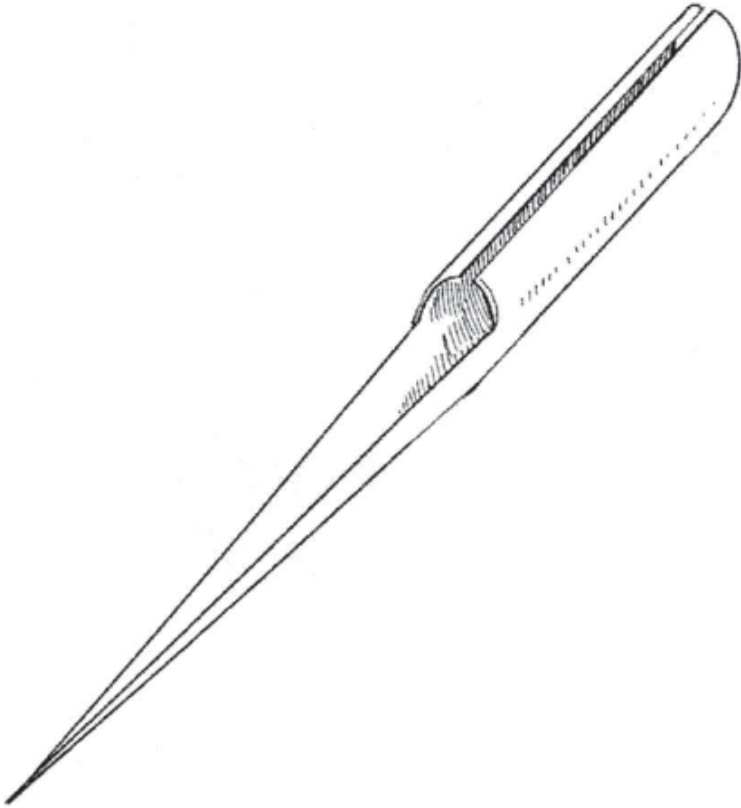

SAMPLING SPEAR

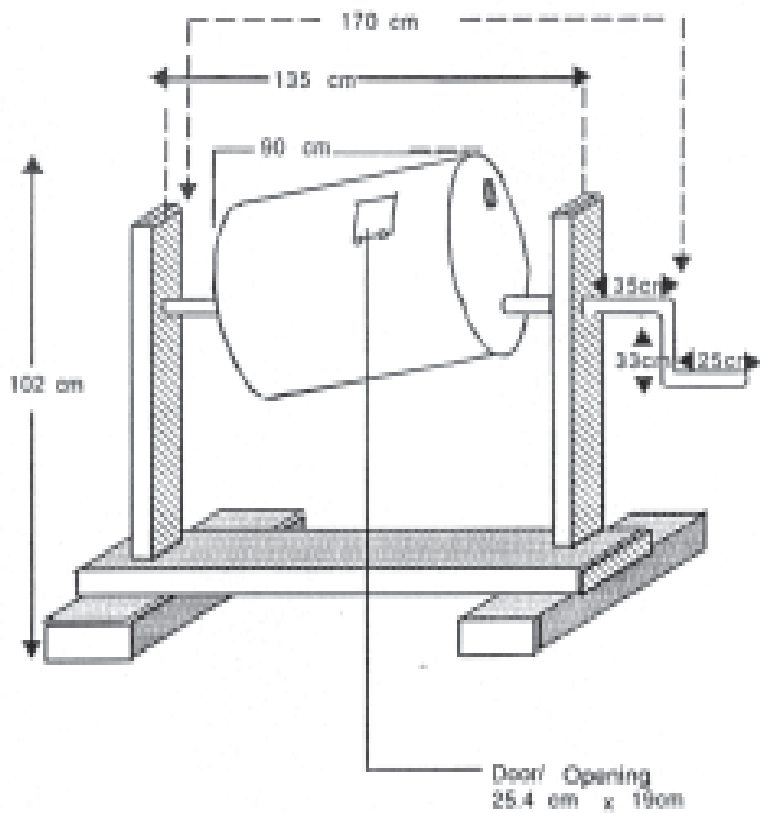

TREATMENT DRUM

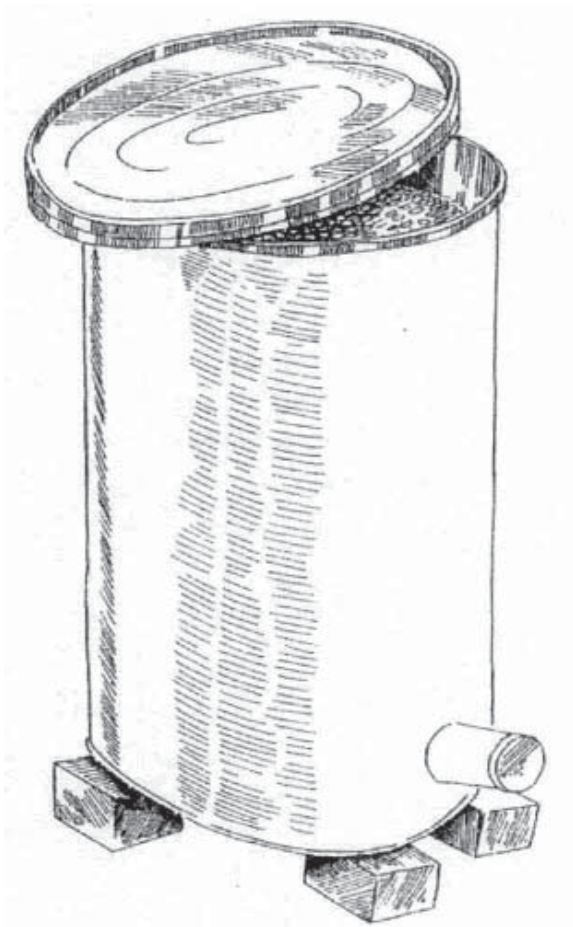

A SILO



The Handbooks for Small-Scale Seed Producers Series is produced by the International Centre for Tropical Agriculture (CIAT)

For more information contact:

**Pan African Coordinator, CIAT
P.O. Box 6247, Kampala, UGANDA
Email: ciat-uganda@cgiar.org**