

Peak Load Limiter N 360
5WG1 360-1AB01
Product and Applications Description

The peak load limiter N 360 is a DIN-rail mounted device used to put down peak loads and may in this manner, perceptibly reduce the user's expenses for availability of power respectively energy. Based on a defined maximum average power value the device disconnects or reconnects loads, however principally overridden by the operator's manual control. Thus only operational loads can fall to a peak load limiter. Each load can be suspended and released by its relevant bus sensor, i.e. this load cannot be used by the peak load limiter for switching during suspension. The device can control up to 120 channels. The current conditions of the channels 1-8 are displayed immediately by LED's placed on the device. For each of the 120 channels the following configurations can be set via the ETS during commissioning:

- disconnection override (1 up to 10)
- minimum connection time period
- minimum disconnection time period
- maximum disconnection time period
- permissible switching cycles per 24 h

The power limit controlled by the peak load limiter, can be set between 30 kW and 1000kW. An alarm threshold between 25kW and 1000kW can be added. If the alarm limit is exceeded a signal is displayed by the LED. These settings can be applied for two rates (high rate and low rate). The required measuring period for determining the maximum average power value can be set at 15, 30 or 60 minutes.

The configuration of the cycle length for the projection periods can be set correspondingly at 15, 30, 60, 120 or 240 seconds. The temporal position of the device within the measuring period is reported via the LEDs. The configuration of the peak load limiter is set via the ETS and the device can be employed without any supplementary software. To visualise the power progress statistics of measuring periods or statistics per day, month or year can be drawn up and transferred by calculation programs for further evaluation by a special software. By this for example statistics of power consumption can be drawn up which can be used for bargaining with the power companies about better conditions for purchasing energy. The software is included within the EIB visualisation and also available as a stand-alone version. Employing the peak load limiter combined with the power statistics software requires a master clock at the EIB which transmits date and time cyclically.

The peak load limiter can also be used as a mere registering unit during a record period. By this load graphs and consumption values can be recorded without having to set configurations for the particular channels.

Application Programs
01 07 peak load limiter 801401

- power limit can be set between 30 kW and 1000 kW
- alarm threshold can be set between 25kW and 1000kW
- measure period for determination of the power average value can be set at 15, 30 and 60 minutes
- time cycles for load projection intervals can be set at 15, 30, 60, 120 and 240 seconds
- overriding settings for switching from 1 up to 10 for each channel
- peak load limitation of 120 channels

Example of Operation

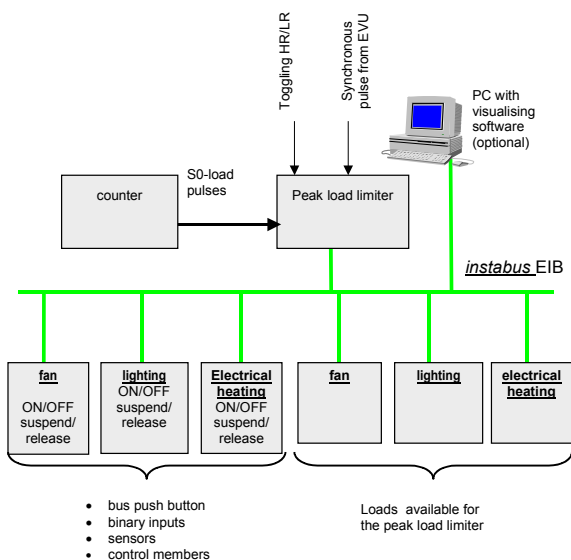

Installation Instructions

- The device may be used for permanent interior installations in dry locations within distribution boards.



WARNING

- The device may be built into distribution boards (230/400 V) together with appropriate VDE-devices and must be mounted and commissioned by an authorised electrician.
- Free DIN rail areas with sticked-in data rail must be covered with covers, order no. 5WG1 192-8AA01.
- The prevailing safety rules must be heeded.
- The device must not be opened. A device suspected faulty should be returned to the local Siemens office.
- A safety disconnection of the device must be possible. Especially if the device is connected to different phases.

Technical Specifications

Power supply

- Bus voltage: via bus line
- External module supply: 230VA±15%

Control elements

1 learning button:
for switching between normal operating mode and addressing mode

Display elements

- 1 green LED "power" displaying the operating voltage
- 1 red LED "!" displaying load excess warnings
- 1 red LED "NoSync" displaying that synchronous pulses are wanted
- 5 yellow LEDs displaying the current temporal position within the measuring period. Each LED signifies one of the following particular ranges: "0%-19%, 20%-39%, 40%-59%, 60%-79%, 80%-99%"
- 8 red/green 2-colour LEDs displaying the state of the particular channel "K1" up to "K8".
If the LED is off the channel is off or the complete peak load limiter is cut off.
Red signifies that this channel has been turned off by the peak limiter.
Green signifies that this channel can be turned off by the peak load limiter.
- Green flashes indicate a running down minimum connection time period
- Red flashes indicate a running down minimum disconnection time period
- Green (0,8s) Red (0,2s) flashes indicate that the channel is switched on, but it's suspended.
- Programming LED:
red for displaying default and programming mode
- programming LED on: programming mode
- programming LED off: default mode

Inputs

- 2 connection blocks ("kWh") for load pulse connection
- 2 connection blocks ("Sync") for EVU synchronous pulse connection
- 2 connection blocks ("Tarif") for EVU rate pulse connection (toggling from low rate period to high rate period). The connection blocks are related to the same reference.



WARNING

- Do not connect the inputs with extraneous voltages.
- A safe disconnection of $U_i=250V$ (SELV) towards the 230V range must be realised by a 230V control device in case of being connected to the S0 inputs.

The pulses for these three inputs are created optionally by a potential free contact or a so-called S0-interface, complying with DIN 43864 respectively IEC 62053-31. The voltage supply happens within the device.

Peak Load Limiter N 360**5WG1 360-1AB01****Connections**

- voltage supply 230V (F1) and S0-load pulses (G1-G6), physical: strip insulation for 9 ... 10 mm permissible conductor types/cross sections:
 - 0,5 ... 2,5 mm² single core or flexible 8 mm ultrasonically compacted
 - 0,5 ... 2,5 mm² flexible conductor with terminal pin crimped on gas tight
 - 0,5...1,5 mm² flexible conductor with connector sleeve
 - 0,5...1,5 mm² plain flexible conductor
- voltage supply 230V (F1) and S0-consumption pulses (G1-G6), electrical:
 - plain flexible conductor, min. 1 mm²: current carrying capacity max. 6 A
 - all other conductors, min. 1,5 mm²: current carrying capacity max. 16 A
- bus line: screwless bus connection blocks 0,6..0,8 mm² ∅ single core

Physical specifications

- housing: plastic
- N-system DIN-rail mounted device, width: 4 SUs (1 SU = 18 mm)
- weight: approx. 240 g
- fire load: approx. 3600 kJ ± 10 %
- installation: rapid mounting on DIN EN 50022-35 x 7,5 rail

Electrical safety

- overvoltage class (according to IEC 60664-1): III
- protection (according to EN 60529): IP 20
- fouling class (according to IEC 60664-1): 2
- device complies with: EN 50090-2-2, EN 60669-2-1 and IEC 60664-1

Electromagnetic compatibility

complies with
EN 50081-1, EN 50082-2 and EN 50090-2-2

Environmental specifications

- climatic conditions: EN 50090-2-2
- ambient temperature operating: - 5 ... + 45 °C
- ambient temperature non-op.: - 25 ... + 70 °C
- relative humidity (non-condensing): 5 % to 93 %

Certification

EIB certificate

CE norm

complies with the EMC regulations (residential and functional buildings), and low voltage regulations.

Location of the display and operator elements

Figure 1: Location of the display and operator elements

- A1...A8: channel state display
- B1...B5: displaying the current temporal position within the measuring period
- C1: display operating voltage
- C2: display load excess warnings
- C3: display that a synchronous pulse is wanted
- D1: display normal operating mode and addressing mode
- E1: bus connection block
- F1: connection blocks for operating voltage 230V
- G1...G6: connection blocks for: toggling from low rate period to high rate period (Tarif) synchronous pulse (Sync) load pulse (kWh)
- S1: learning button for switching between normal operating mode

Mounting and Wiring

General description

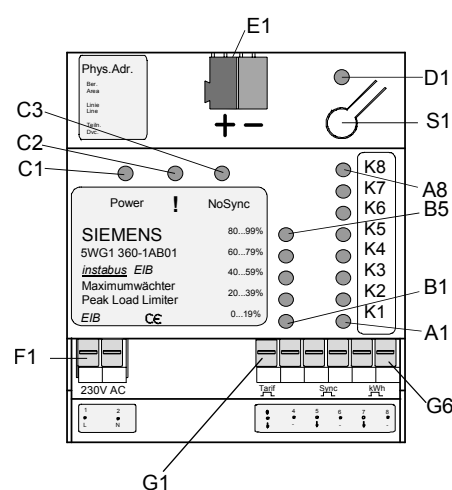
The N-system DIN-rail device (4 SUs) can be installed to N-system distribution boards, surface or flush mounted, or to any DIN-rail EN 50022-35 x 7,5 available that has a data rail installed.

The connection to the bus line is established via bus connection blocks or by clicking the device onto the DIN-rail (with a data rail installed). Take care that the type plates of all devices on a DIN-rail can be read in the same direction, guaranteeing the devices are polarised correctly.

If the connection is established via bus connection block (data rail not installed) the data rail connection system has to be covered with the enclosed insulation top after removing the stabiliser clip e.g. with a screw driver to guarantee a sufficient insulation from the DIN rail.

If the peak load limiter N 360 is installed the conventional adapter is not necessary (also for other DIN-rail devices). The bus voltage is downloaded from the bus connection block to the data rail.

Mounting DIN-rail devices (Figure 2)

- Slide the device (B1) onto the DIN-rail (B2) and
- swivel back the device until the slide clicks into place audibly.

Dismounting DIN-rail devices (Figure 2)

- Remove all connected wires,
- press down the two slides (C3) with a screw-driver and
- swivel the device (C1) from the DIN-rail (C2).

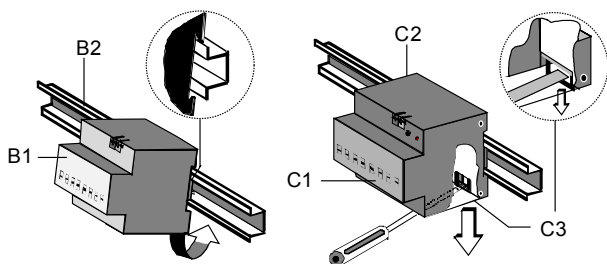

Figure 2: Mounting and dismounting a DIN-rail device

Removing the stabiliser clip (Figure 3)

- The stabiliser clip (D3) surrounds the contact system (D2) on the back side of the peak load limiter N 360 (D1).
- Insert the screw driver between the DIN-rail device (D1) and the stabiliser clip (D3) and remove the stabiliser clip.

Inserting the insulation top (Figure 3)

- Put the insulation top (D4) onto the contact system and click it into place by a slight pressure.

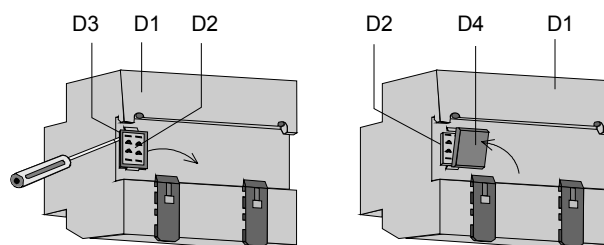

Figure 3: Insulation of the contact system

Slipping off bus connection blocks (Figure 4)

- The bus connection block (E1) is situated on the top of the peak load limiter N 360 (E2).
- The bus connection block (E1) consists of two components (E1.1 and E1.2) with four terminal contacts each. Take care not to damage the two test sockets (E1.3) by accidentally connecting them to the bus cable or with the screw-driver (e.g. when attempting to unplug the bus connection block).
- Carefully put the screw-driver to the wire-inserting slit of the bus connection block's grey component and pull the bus connection block (E1) from the peak load limiter N 360 (E2).

Note:

Don't try to remove the bus connection block from the bottom side! There is a risk of shorting-out the device!

Slipping on bus connection blocks (Figure 4)

- Slip the bus connection block onto the guide slot and
- press the bus connection block (E1) down to the stop.

Peak Load Limiter N 360**5WG1 360-1AB01**Connecting bus cables (Figure 4)

- The bus connection block (E1) can be used with single core conductors $\varnothing 0,6 \dots 0,8$ mm.
- Remove approx. 5 mm of insulation from the conductor (E1.4) and insert it into the bus connection block (E1) (red = +, black = -).

Disconnecting bus cables (Figure 4)

- Unplug the bus connection block (E1) and remove the bus cable conductor (E1.4) while simultaneously wiggling it.

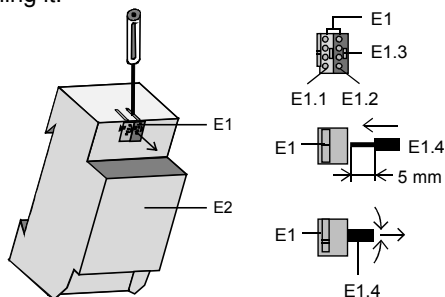

Figure 4: Connecting and disconnecting bus wires

Connecting load circuits (Figure 5)

- The connections of the circuits consist of screwless connection blocks
- Remove approx. 8 to 9 mm of insulation from the wire (F1.1) and plug it into the terminal (F1) and tighten the screws (F1.2)

cross sections

load circuit, physical:

strip insulation for 9 ... 10 mm

permissible conductor types/cross sections:

- 0,5 ... 2,5 mm² single core or flexible 8 mm ultrasonically compacted
- 0,5 ... 2,5 mm² flexible conductor with terminal pin crimped on gas tight
- 0,5...1,5 mm² flexible conductor with connector sleeve
- 0,5...1,5 mm² plain flexible conductor

Disconnect load circuits (Figure 5)

- apply a pressure onto the terminal interlocking with a screwdriver and
- remove the wire (F1.1) from the terminal (F1).

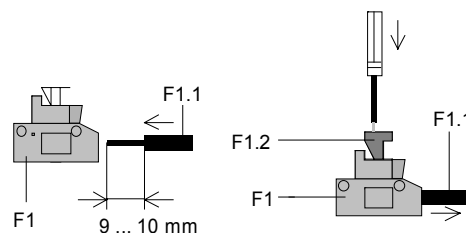
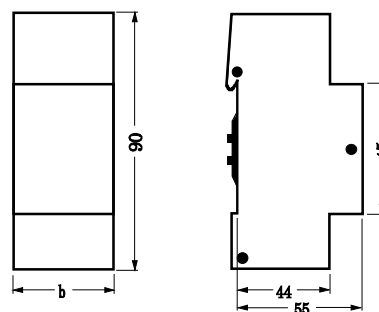

Figure 5: Connecting and disconnecting load circuits

Dimension Diagram

Dimensions in mm



b = 4 SU

1 Spacer unit (SU) = 18mm

instabus EIB

Technical Product Information

September 2001

Peak Load Limiter N 360

5WG1 360-1AB01

Notes