



Product Brochure

NEMA Super-E[®] Premium efficient motors

NEMA Super-E[®] premium efficient motors

General information

We are to be the best – as determined by our customers – marketers, designers and manufacturers of industrial electric motors, generators and mechanical power transmission products.

With expertise, and a comprehensive portfolio of products and life-cycle services, we help value-minded industrial customers improve their energy efficiency and productivity.



NEMA Super-E[®] premium efficient motors

Table of contents

2	Energy savings
3	Super-E [®] TEFC design features
6	TEFC three phase capabilities
7	TEFC foot mounted
10	TEFC F2 mounted
11	TEFC C-face foot mounted
13	TEFC C-face footless
14	Super-E [®] ODP design features
15	ODP three phase capabilities
16	ODP foot mounted
18	ODP, small motor rule, single phase, foot mounted
19	ODP, small motor rule, three phase, foot mounted
20	ODP F2 mounting
20	ODP C-face foot mounted
21	Close coupled pump TEFC & ODP with Aegis [®] grounding ring
22	Close coupled pump motor – TEFC
23	Close coupled pump motor – ODP
24	Vertical P-base
25	HVAC
29	Chiller/cooling tower
30	Single phase
32	200 Volt
34	Unit handling
36	Brake
38	Adjustable speed capabilities
39	Conduit box volumes
39	Approvals UL and CSA
40	Dimension drawings
58	Connection drawings

NEMA Super-E[®] premium efficient motors

Energy savings

Super-E[®] motors are another example of our commitment to provide reliable performance, while exceeding customer expectations.

Standard on All Baldor•Reliance[®] Motors: Mobil Polyrex[®] EM Polyurea Grease

It's a fact: Bearing failure is the #1 mechanical reason for motor failure. So the better the grease protecting those bearings, the better and longer the motor performs.

Today, that better grease is Mobil Polyrex[®] EM polyurea grease – now standard on all Baldor•Reliance motors. It provides lubrication life of more than four times greater than other polyurea greases in tests up to 176 °C (350°F). It exhibits greater durability when subjected to mechanical shearing forces. Furthermore, a specially formulated additive in the grease resists washout, rust and corrosion even when subjected to salt water conditions.

Purchase price is only a small piece of the pie

The pie chart to the right shows the typical life cycle cost of a 75kW (100 hp) motor operating in continuous duty over a 20-year life. As you can see, the original purchase price is almost insignificant compared to what it will cost to power the motor during its useful life.

How Baldor•Reliance[®] Super-E[®] efficiencies compare to industry standards

Super-E motors offer customers the highest level of overall efficiencies available from any motor manufacturer, meeting or exceeding NEMA Premium[®] efficiency.

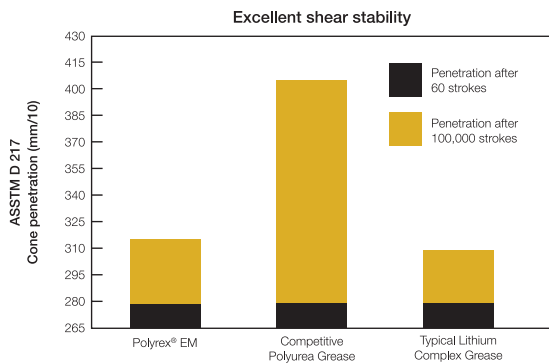

As illustrated here, the proprietary polyurea thickener system in Polyrex[®] EM exhibits excellent durability and stability when subjected to a mechanical shearing force. Mechanical shear stability is a measurement of the greases thickener system. Good mechanical shear stability is important in roller bearing applications where excessive grease softening may lead to grease leakage or purging from the bearing.
Source: Exxon Mobil product data sheet DG-3C, 6/15/99.

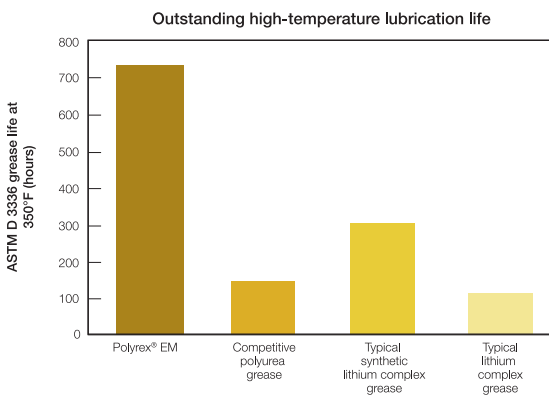

In the severe ASTM D 3336 High-Temperature Grease Life Test, Polyrex[®] EM dramatically out performed a competitive polyurea grease and conventional lithium-complex greases.
Source: Exxon Mobil product data sheet DG-3C, 6/15/99.

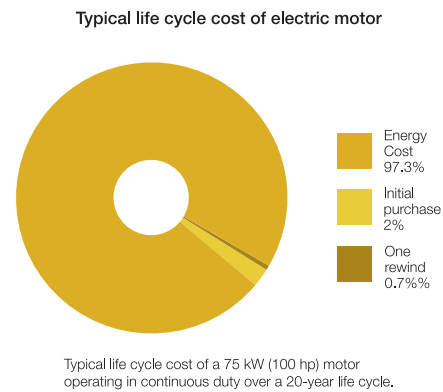

Typical life cycle cost of a 75 kW (100 hp) motor operating in continuous duty over a 20-year life cycle.

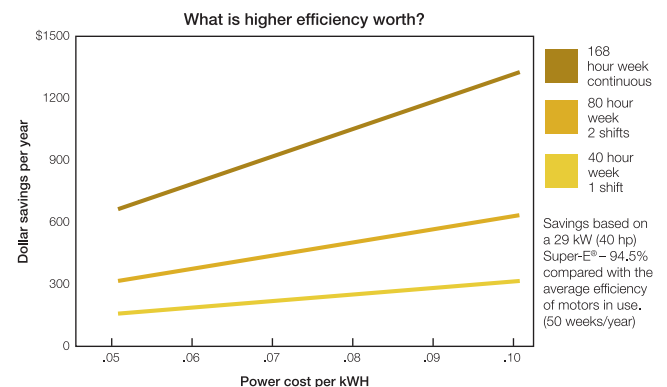
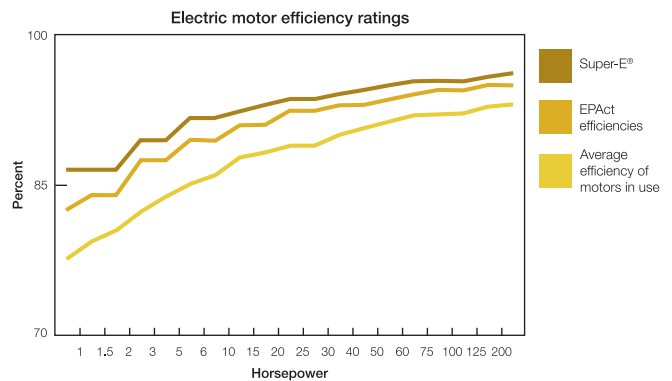

Savings based on a 29 kW (40 hp) Super-E[®] – 94.5% compared with the average efficiency of motors in use. (50 weeks/year)

Making energy efficiency work for you

Why is energy efficiency important?

Electric motor-driven systems used in industrial processes consume the majority of all electricity used in the industrial sector. Companies can actually average as much as 33 percent savings if they were to apply motor and motor system efficiency upgrades, including the use of adjustable speed drives. The potential positive impacts on companies' bottom lines and the environment are significant.

NEMA Super-E[®] premium efficient motors

Totally enclosed fan cooled (TEFC)

Motor design features

The family of Baldor•Reliance[®] Super-E TEFC (totally-enclosed fan-cooled) motors share a number of electrical and mechanical features that add up to outstanding value. “EM” motors are general-purpose premium efficient motors. For more severe environmental applications, our “ECP/XEX” severe duty motors provide added weather and chemical protection. For extreme applications, where downtime is critical, Baldor•Reliance[®] “841XL” motors are ideal; these motors exceed IEEE 841-2001 specifications.

The chart below lists standard features (“S”) in Baldor•Reliance TEFC premium efficient motors. Horsepower ranges indicate where certain features are standard in stock products. Additional features optional (“O”) are available on custom motors or through Mod-Express.

TEFC premium efficiency motor family

Electrical features	EM/XE	ECP/XEX	841XL
kW (hp) range - stock	0,75-300 (1-400)	0,75-300 (1-400)	0,75-187 (1-250)
Class F insulation with Class B rise	S	S	S
1.15 service factor	S	S	S
200°C Inverter Spike Resistant insulation system	S	S	S
Phase insulation	S	S	S
Corona inception testing - meets NEMA Part 31.4.4.2	S	S	S
Varnish dip & bake with 100% solids	S	S	S
No silicone lead wire	S	S	S
Documented final motor tests - data shipped with motor	O	O	S
Mechanical features	EM/XE	ECP/XEX	841XL
NEMA frame sizes	143T - 449T	143T - 449T	143T - 449T
Steel bandframe die cast aluminum endplates, steel fan cover	S 143T - 215T	-	-
Cast iron frame - cast iron endplates & fan cover (steel fan cover standard on EM/XE 140-280T)	O 143T - 286T S 324T - Up	S	S
Die cast aluminum conduit box	S thru 360T	-	-
Cast iron conduit box	S 400T - up	S	S
Threaded inlet hole in conduit box	O	S	S
Neoprene conduit box lid gasket & lead separator gasket	O cast iron only	S	S
Seal endplate to frame joints	O	S	S
V-ring shaft seals - DE & ODE (except some 440 frame)	S 250T - up DE only	S	-
Inpro/Seal [®] VBX or VBXX bearing isolators - DE and ODE	-	-	S
Hardware - zinc plated	S	S	S
Motor unfiltered vibration at rated voltage and frequency <38,1 mm/s (<0,15 in/s) peak velocity	S	S	-
Motor unfiltered vibration at rated voltage and frequency <2,03 mm/s (<0,08 in/s) peak velocity	O	O	S
Test vibration on DE & ODE and document - ship with motor	O	O	S
Low bearing temperature specs (IEEE 841)	-	-	S
Foot flatness to < NEMA tolerances (0.005"/ft.)	-	-	S
Shaft runout < NEMA	-	-	S
Sound power level < 90 dBA	-	-	S
Grease inlet fitting - grease fitting	S	-	-
Grease inlet with tube extension & grease fitting	-	S	S
Grease outlet with screw-in plug	S	O	O
Grease outlet with automatic relief fitting	S 250T - up	-	-
Grease outlet with tube extension & automatic relief fitting	-	S	S
Non-metallic external cooling fan	S	S	S
Casting coated with water base primer	S	-	-
Castings coated with 2-part epoxy primer and epoxy finish coat	-	S	S
Finish paint with gold enamel	S	-	-
Finish paint with 2-part dark gray epoxy	O	S	S
ASTM B117-90 96-hour salt spray test compliance	-	S	S
Laser etched aluminum nameplate with NEMA data	S	-	-
Embossed stainless steel nameplate with NEMA data	-	S	S
Stainless steel nameplate with bearing and grease data	O	S	S
Limited warranty	3 year	3 year	5 year

Note: Contact your your regional support office for certified data, dimensions and features of a specific motor.

NEMA Super-E[®] premium efficient motors

NEMA Super-E[®]: premium efficiency inside and out

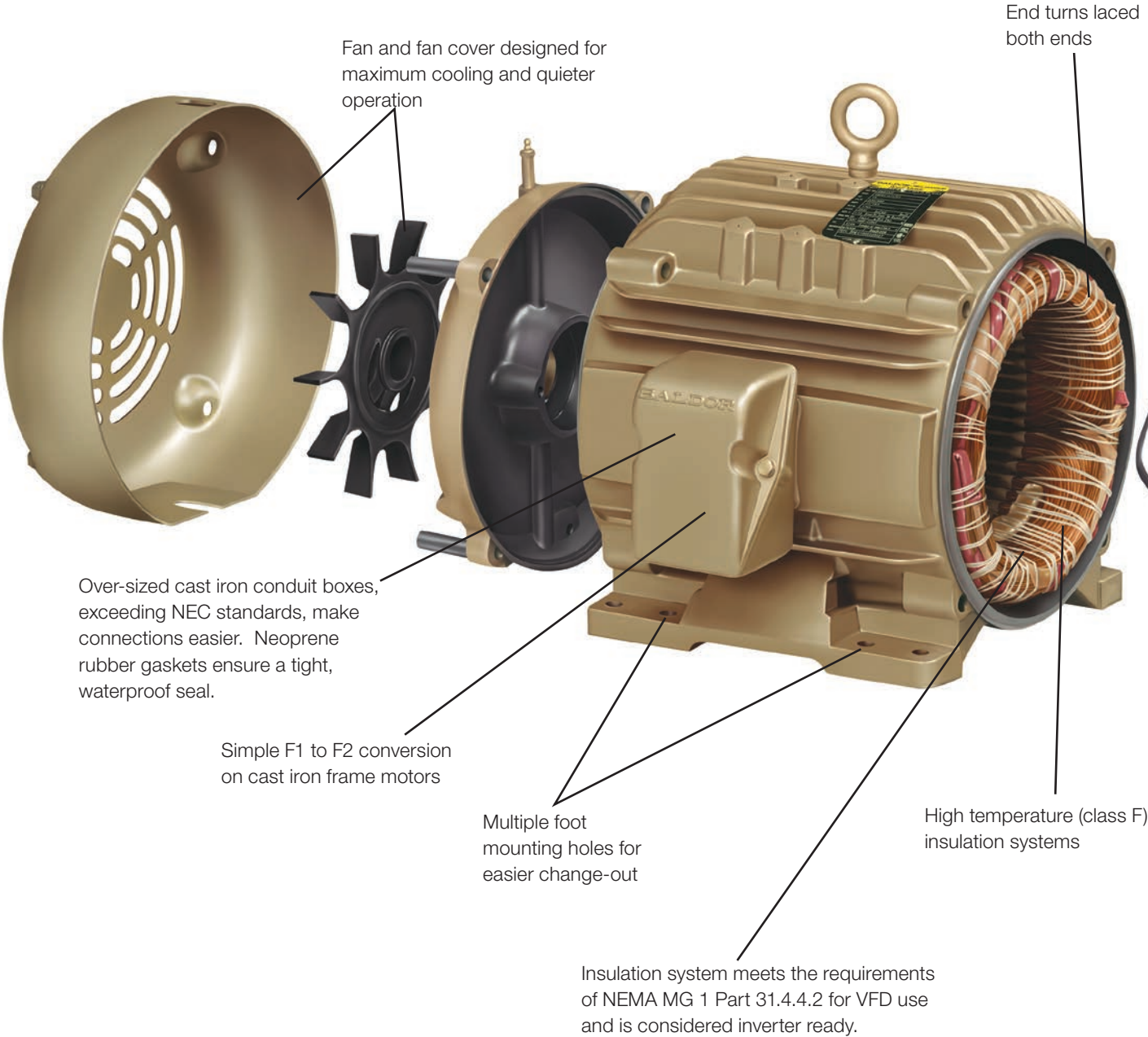

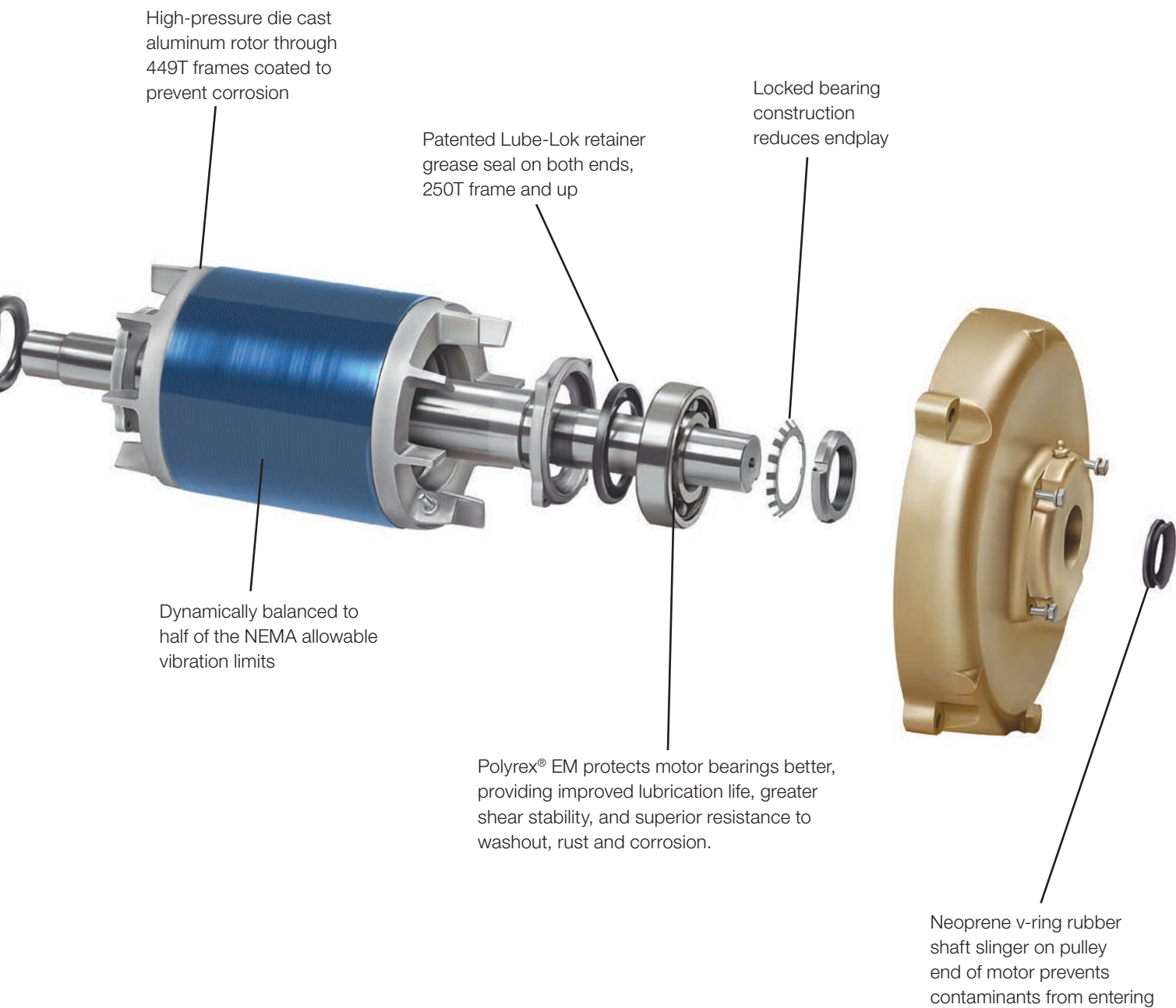

NEMA Super-E[®] premium efficient motors

Totally enclosed fan cooled capabilities

Three phase

Three phase - typical frame size / Hp - speed

kW	Hp	3600		1800		1200		900
0.75	1	56	◆	56, 143T or 182	◆	56 or 145T	◆	182T
1.12	1.5	143T	◆	56, 145T or 184	◆	145T or 182T	◆	184T
1.5	2	145T	◆	56, 145T or 184	◆	184T	◆	213T
2.2	3	145T, 182T or 184	◆	182T or 213T	◆	213T	◆	215T
4	5	184T	◆	184T or 215T	◆	215T	◆	254T
5.6	7.5	184T or 213T	◆	213T	◆	254T	◆	256T
7.5	10	215T	◆	215T	◆	256T	◆	286T
11	15	254T	◆	254T	◆	284T	◆	286T
15	20	256T	◆	256T	◆	286T	◆	324T
18.7	25	284TS	◆	284T	◆	324T	◆	326T
22.4	30	286TS	◆	286T	◆	326T	◆	364T
29	40	324TS	◆	324T	◆	364T	◆	365T
37	50	326TS	◆	326T	◆	365T	◆	404T
44	60	365TS	◆	364T	◆	404T	◆	405T
56	75	365TS	◆	365T	◆	405T	◆	444T
75	100	405TS	◆	405T	◆	444T	◆	445T
93	125	444TS	◆	444T	◆	445T	◆	447T
112	150	447TS or 449T	◆	445T or 449T	◆	447T or 449T	◆	449T
149	200	447TS or 449T	◆	447T or 449T	◆	449T	◆	-
187	250	449TS	◆	449T	◆	449TY	◆	-
224	300	449TS	◆	449TY	◆	449TY	◆	-
261	350	449TS	◆	449TY	◆	-	◆	-
298	400	449TS	◆	-	◆	-	◆	-

Notes: ◆ Denotes product scope of NEMA Premium[®] efficiency motor program.

Motors listed with catalog numbers in this brochure are available from stock. Contact your ABB regional support office for lead times on non-stock motors.

Performance data is subject to change. Drawings shown are for reference only. Please contact your ABB regional sales office for current performance data or a detailed drawing on the specific motor you require. Data and drawings may be available from our website at www.baldor.com.

Premium efficiency in metric frames

NEMA Super-E[®] motors are available in IEC frames 63 through 500 with base, B5 flange or B14 C-face.

Motors can be supplied for 50 or 60 Hz operation.

Contact your ABB regional support office for more information.

NEMA Super-E[®] premium efficient motors

TEFC

Foot mounted

Baldor•Reliance[®] Super-E[®] TEFC motors meet or exceed NEMA Premium[®] efficiency in your choice of steel-band or cast iron frame, ideal for tough industrial applications. The TEFC enclosure protects the motor from harsh environments because air does not pass freely through the motor. An external shaft-driven fan circulates air over the frame housing. class F insulation, a 1.15 service factor and Mobil Polyrex[®]EM grease are some of these motors' standard features. Super-E motors have an insulation system that meets the requirements of NEMA MG1 Part 31.4.4.2 for VFD use and are considered inverter ready. TEFC motors are available in single or three phase, rigid base or C-face (with or without base).



TEFC - totally enclosed fan cooled – foot mounted, 230/460, 460 & 575 volts, three phase, 0.37-149 kW (1/2 - 200 hp)

kW	Hp	RPM	Frame	Catalog number	Amps @ high V		F.L. torque Nm (lb-ft)	Efficiency %			Power factor %			Bearings		Volt code	"C" dim. mm (in)	Conn. diag. no.	Notes
					Full load	Locked rotor		1/2	3/4	Full load	1/2	3/4	Full load	DE	ODE				
230/460 & 460 Volts																			
0,37	1/2	1735	56	EM3538	0.8	5.6	2.03 (1.5)	80.3	82.5	82.5	52	64	74	6205	6203	E1	310,64 (12.23)	CD0005	-
0,75	1	3450	56	EM3545	1.4	9	2.03 (1.5)	67.8	73.1	77	74	2	87	6205	6203	F	311,15 (12.25)	CD0005	-
0,75	1	1760	56	EM3546	1.5	12.1	4.07 (3)	82.1	84.8	85.5	49	62	71	6205	6203	E	310,64 (12.23)	CD0005	-
0,75	1	1760	143T	EM3546T	1.5	12.1	4.07 (3)	82.1	84.8	85.5	49	62	71	6205	6203	E	312,67 (12.31)	CD0005	-
0,75	1	1760	143T*	EM3581T	1.5	12.1	4.07 (3)	82.1	84.8	85.5	49	62	71	6205	6203	E	318,26 (12.53)	CD0005	-
0,75	1	1155	56	EM3556	1.8	10.8	6.10 (4.5)	79.4	82.3	82.5	43	55	64	6205	6203	E	336,04 (13.23)	CD0005	-
0,75	1	1155	145T	EM3556T	1.8	10.8	6.10 (4.5)	79.4	82.3	82.5	43	55	64	6205	6203	E	338,07 (13.31)	CD0005	-
0,75	1	1155	145T*	EM3582T	1.7	10.2	6.10 (4.5)	81.3	83.5	82.5	44	56	65	6205	6203	E	318,26 (12.53)	CD0005	-
1,1	1 1/2	3500	56	EM3550	1.9	17.9	2.98 (2.2)	82.2	84.4	84	67	79	85	6205	6203	E	311,15 (12.25)	CD0005	-
1,1	1 1/2	3500	143T	EM3550T	1.9	17.9	2.98 (2.2)	82.2	84.4	84	67	79	85	6205	6203	E	312,17 (12.29)	CD0005	-
1,1	1 1/2	3500	143T*	EM3583T	1.9	17.9	2.98 (2.2)	82	84.6	84	67	79	85	6205	6203	E	318,26 (12.53)	CD0005	-
1,1	1 1/2	1760	56	EM3554	2.2	13.3	6.10 (4.5)	84.5	86.8	86.5	51	65	73	6205	6203	E	336,04 (13.23)	CD0005	-
1,1	1 1/2	1760	145T	EM3554T	2.2	18.3	6.10 (4.5)	84.5	86.8	86.5	51	65	73	6205	6203	E	338,07 (13.31)	CD0005	-
1,1	1 1/2	1765	145T*	EM3584T	2.3	20.7	6.10 (4.5)	83.8	86.4	86.5	49	62	71	6205	6203	E	318,26 (12.53)	CD0005	-
1,1	1 1/2	1170	182T	EM3607T	2.6	14.7	9.22 (6.8)	86	88.3	87.5	42	53	62	6206	6205	E	420,37 (16.55)	CD0005	-
1,1	1 1/2	1170	182T*	EM3667T	2.5	16.2	9.22 (6.8)	84.8	86.9	87.5	44	56	64	6206	6205	E	387,10 (15.24)	CD0005	-
1,5	2	3490	56	EM3555	2.5	25.9	4.07 (3)	83.5	85.9	85.5	75	84	88	6205	6203	E	336,55 (13.25)	CD0005	-
1,5	2	3490	145T	EM3555T	2.5	25.9	4.07 (3)	83.5	85.9	85.5	75	84	88	6205	6203	E	338,07 (13.31)	CD0005	-
1,5	2	3490	145T*	EM3586T	2.5	25.9	4.07 (3)	83.5	85.9	85.5	75	84	88	6205	6203	E	318,77 (12.55)	CD0005	-
1,5	2	1755	56	EM3558	2.9	24.3	8.13 (6)	84.2	86.4	86.5	51	64	73	6205	6203	E	358,14 (14.1)	CD0005	-
1,5	2	1755	145T	EM3558T	2.9	24.3	8.13 (6)	84.2	86.4	86.5	51	64	73	6205	6203	E	360,43 (14.19)	CD0005	-
1,5	2	1750	145T*	EM3587T	2.9	25	8.13 (6)	85.1	87.1	86.5	53	66	75	6205	6203	E	318,26 (12.53)	CD0005	-
1,5	2	1170	184T	EM3614T	3.5	20.9	12.20 (9)	86.7	88.6	88.5	41	53	60	6206	6205	E	458,47 (18.05)	CD0005	-
1,5	2	1165	184T*	EM3664T	3.2	20.9	12.20 (9)	86.9	88.5	88.5	48	60	68	6206	6205	F	387,10 (15.24)	CD0005	-
2,2	3	3450	145T	EM3559T	3.6	33	6.10 (4.5)	87.9	88.2	86.5	81	88	92	6205	6203	E	360,43 (14.19)	CD0005	-
2,2	3	3450	182T	EM3610T	3.7	33.3	6.37 (4.7)	86.2	87.3	86.5	82	88	91	6206	6205	E1	385,57 (15.18)	CD0005	-
2,2	3	3460	182T*	EM3660T	3.8	30.9	6.37 (4.7)	86.5	87.4	86.5	76	84	88	6206	6205	E	387,10 (15.24)	CD0005	-
2,2	3	1760	182T	EM3611T	4.2	32	12.07 (8.9)	87.8	89.5	89.5	54	68	75	6206	6205	E	420,37 (16.55)	CD0005	-
2,2	3	1755	182T*	EM3661T	4.1	29.8	12.34 (9.1)	88.9	90.1	89.5	58	70	77	6206	6205	E	387,10 (15.24)	CD0005	-
2,2	3	1160	213T	EM3704T	4.6	34.4	18.17 (13.4)	87.7	89.4	89.5	49	61	68	6307	6206	E1	483,11 (19.02)	CD0005	-
2,2	3	1165	213T*	EM3764T	4.5	33.2	18.44 (13.6)	88.1	89.5	89.5	53	64	71	6307	6206	E	468,63 (18.45)	CD0005	-
3,7	5	3450	184T	EM3613T	5.9	57.2	10.44 (7.7)	88.9	89.4	88.5	81	88	91	6206	6205	E1	420,37 (16.55)	CD0005	-
3,7	5	3475	184T*	EM3663T	6.3	51.7	10.17 (7.5)	87.8	89	88.5	64	77	84	6206	6205	E	387,10 (15.24)	CD0005	-
3,7	5	1750	184T	EM3615T	6.7	49.1	20.20 (14.9)	89.7	90.3	89.5	60	72	78	6206	6205	E	458,47 (18.05)	CD0005	-
3,7	5	1750	184T*	EM3665T	6.6	45.5	20.34 (15)	89.8	90.3	89.5	63	73	79	6206	6205	E	387,10 (15.24)	CD0005	-
3,7	5	1160	215T	EM3708T	7.3	51.6	30.78 (22.7)	89.8	90.4	89.5	55	66	73	6307	6206	E	502,16 (19.77)	CD0005	-
3,7	5	1160	215T*	EM3768T	7.4	50.6	30.51 (22.5)	89.9	90.3	89.5	54	65	71	6307	6206	E	468,63 (18.45)	CD0005	-

Notes: Volt code: E = 208-230/460V, 60 Hz; E1 = 230/460V, 60 Hz, usable at 208V; F = 230/460V, 60 Hz

* Ratings are cast iron frames.

See pages 40 and 41 for layout drawings. See page 58 for connection diagrams.

Efficiencies shown are nominal. Data subject to change without notice. Contact your ABB regional support office for certified data.

NEMA Super-E[®] premium efficient motors

TEFC

Foot mounted



TEFC - totally enclosed fan cooled – foot mounted, 230/460, 460 & 575 volts, three phase, 0.37-149 kW (1/2 - 200 hp)

kW	Hp	RPM	Frame	Catalog number	Amps @ high V		F.L. torque Nm (lb-ft)	Efficiency %			Power factor %			Bearings		Volt code	"C" dim. mm (in)	Conn. diag. no.	Notes
					Full load	Locked rotor		1/2	3/4	Full load	1/2	3/4	Full load	DE	ODE				
230/460 & 460 Volts (continued)																			
5,6	7.5	3450	184T	EM3616T	8.4	91	15,46 (11.4)	90.6	90.7	89.5	85	90	93	6206	6205	E	458,47 (18.05)	CD0005	-
5,6	7.5	3525	213T	EM3709T	9	83.4	15,19 (11.2)	92.1	92.9	91	76	84	86	6307	6206	E	454,41 (17.89)	CD0005	-
5,6	7.5	3525	213T*	EM3769T	8.6	75	15,19 (11.2)	90	91.4	91	79	87	90	6307	6206	E1	468,63 (18.45)	CD0005	-
5,6	7.5	1770	213T	EM3710T	9.4	70.1	30,37 (22.4)	92.2	92.7	91.7	63	75	81	6307	6206	E1	483,11 (19.02)	CD0005	-
5,6	7.5	1770	213T*	EM3770T	9.5	68	29,96 (22.1)	91.6	92.3	91.7	65	76	81	6307	6206	E1	468,63 (18.45)	CD0005	-
5,6	7.5	1180	254T*	EM2276T	10.7	67	43,93 (32.4)	89.3	90.7	91	53	64	70	6309	6208	E1	588,26 (23.16)	CD0005	-
7,5	10	3490	215T	EM3711T	11.8	78.5	20,34 (15)	91	91.3	90.2	74	84	87	6307	6206	E	454,41 (17.89)	CD0005	-
7,5	10	3500	215T*	EM3771T	11.8	88.5	20,20 (14.9)	93	93.2	90.2	79	88	90	6307	6206	E1	468,63 (18.45)	CD0005	-
7,5	10	1770	215T	EM3714T	12	103	40,00 (29.5)	92.1	92.4	91.7	66	79	85	6307	6206	E	521,21 (20.52)	CD0005	-
7,5	10	1760	215T*	EM3774T	12.2	81	40,40 (29.8)	92.5	92.9	91.7	71	80	83	6307	6206	E1	468,63 (18.45)	CD0005	-
7,5	10	1180	256T*	EM2332T	14.4	95.1	60,20 (44.4)	89.9	91.3	91	55	65	71	6309	6208	E1	588,26 (23.16)	CD0180	-
11	15	3500	215T	EM3713T	17	161	30,51 (22.5)	91.5	91.8	91	87	92	93	6307	6206	E	521,21 (20.52)	CD0005	-
11	15	3520	254T*	EM2394T	17.5	110	29,96 (22.1)	91	91.6	91	77	85	87	6309	6208	E1	588,26 (23.16)	CD0180	-
11	15	1765	254T*	EM2333T	18.5	122.9	60,47 (44.6)	91.9	92.6	92.4	66	77	82	6309	6208	E1	588,26 (23.16)	CD0005	-
11	15	1175	284T*	EM4100T	21	125	90,16 (66.5)	90.6	91.8	91.7	54	66	73	6311	6309	E1	705,10 (27.76)	CD0180	-
15	20	3520	256T*	EM4106T	23	161	40,13 (29.6)	92.2	92.4	91	78	86	89	6309	6208	E1	588,26 (23.16)	CD0005	-
15	20	1765	256T*	EM2334T-12	23	168	79,99 (59)	92.9	93.2	93	74	80	85	6309	6208	E1	588,26 (23.16)	CD0104	-
15	20	1765	256T*	EM2334T	24	175	79,99 (59)	92.8	93.1	93	69	80	84	6309	6208	E1	588,26 (23.16)	CD0005	-
15	20	1180	286T*	EM4102T	27	165	121,21 (89.4)	91.1	91.9	91.7	60	71	77	6311	6309	E	705,10 (27.76)	CD0180	-
19	25	3520	256T*	EM4118T	27	206	50,44 (37.2)	92.2	92.8	91.7	87	91	93	6309	6208	F	591,31 (23.28)	CD0180	-
19	25	3525	284TS*	EM4107T	29	249	50,17 (37)	89.2	91.2	91.7	75	83	90	6311	6208	E1	627,38 (24.7)	CD0005	-
19	25	1770	284T*	EM4103T	30	186	100,60 (74.2)	92.3	93.5	93.6	73	81	85	6311	6309	E1	705,10 (27.76)	CD0005	-
19	25	1770	284T*	EM4103T-12	30	186	100,60 (74.2)	92.3	93.5	93.6	73	81	85	6311	6309	E1	700,02 (27.56)	CD0104	25
19	25	1180	324T*	EM4111T	32	220	151,85 (112)	92.6	93.3	93	63	73	79	6312	6309	E1	771,91 (30.39)	CD0180	-
22	30	3520	286TS*	EM4108T	34	288	60,33 (44.5)	90.8	91.9	91.7	81	87	90	6311	6208	E1	627,38 (24.7)	CD0180	-
22	30	1760	286T*	EM4104T	38	270	120,26 (88.7)	92.3	93.5	93.6	63	73	80	6311	6309	E1	705,10 (27.76)	CD0180	-
22	30	1760	286T*	EM4104T-12	36	238	120,40 (88.8)	92.5	93.5	93.6	72	80	85	6311	6309	F	705,10 (27.76)	CD0104	25
22	30	1180	326T*	EM4117T	39	243	180,32 (133)	92.5	93.2	93	62	73	78	6312	6311	E1	769,11 (30.28)	CD0005	-
30	40	3530	324TS*	EM4109T	46	305	80,26 (59.2)	91.6	92.6	92.4	79	86	88	6312	6311	E1	731,01 (28.78)	CD0180	-
30	40	1775	324T*	EM4110T	48	338	159,99 (118)	93.5	94.2	94.1	69	78	83	6312	6311	E1	769,11 (30.28)	CD0180	-
30	40	1770	324T*	EM4110T-12	48	349	159,99 (118)	93.7	94.5	94.1	69	79	83	6312	6311	E1	769,11 (30.28)	CD0104	25
30	40	1190	364T*	EM4308T	49.4	290	239,98 (177)	93.6	94.3	94.1	69	77	81	6313	6313	E1	849,38 (33.44)	416820-2	-
37	50	3540	326TS*	EM4114T	56	408	100,87 (74.4)	93.8	94.2	93	82	88	90	6312	6311	E	734,06 (28.9)	CD0180	-
37	50	1775	326T*	EM4115T	58	397	199,31 (147)	94.3	94.8	94.5	74	83	86	6312	6311	E	769,11 (30.28)	CD0180	-
37	50	1775	326T*	EM4115T-12	58	397	199,31 (147)	94.3	94.8	94.5	74	83	86	6312	6311	F	769,11 (30.28)	CD0104	25
37	50	1775	326TS*	EM4115TS	58	397	199,31 (147)	94.3	94.8	94.5	74	83	86	6312	6311	F	731,01 (28.78)	CD0180	-
37	50	1185	365T*	EM4312T	61.7	345	299,64 (221)	93.9	94.4	94.1	70	78	81	6313	6313	E1	849,38 (33.44)	416820-2	-
45	60	3560	364TS*	EM4310T	65.1	398	119,99 (88.5)	95.3	95.5	95	88	91	91	6313	6313	E1	795,27 (31.31)	416820-2	-
45	60	1780	364T*	EM4314T	68	430	239,98 (177)	95.2	95.3	95	79	85	87	6313	6313	E1	849,38 (33.44)	416820-2	-
45	60	1780	364T*	EM4314T-12	68	430	239,98 (177)	95.2	95.3	95	79	85	87	6313	6313	F	849,38 (33.44)	416820-2	25
45	60	1780	364TS*	EM4314TS	68	430	239,98 (177)	95.2	95.3	95	79	85	87	6313	6313	F	795,27 (31.31)	416820-2	-
45	60	1185	404T*	EM4403T	69	425	359,29 (265)	94.9	95.2	95	79	84	86	6316	6316	E1	966,72 (38.06)	416820-2	-
56	75	3555	365TS*	EM4313T	80.7	494	150,50 (111)	95.1	95.4	95	91	92	92	6313	6313	E1	795,27 (31.31)	416820-2	-
56	75	1780	365T*	EM4316T	84.9	542	299,64 (221v)	95.7	95.8	95.4	77	84	86	6313	6313	E1	849,38 (33.44)	416820-2	-
56	75	1780	365T*	EM4316T-12	85.9	542	299,64 (221)	95.7	95.8	95.4	77	84	86	6313	6313	F	849,38 (33.44)	416820-2	25
56	75	1780	365TS*	EM4316TS	85.9	542	299,64 (221)	95.7	95.8	95.4	77	84	86	6313	6313	F	795,27 (31.31)	416820-2	-
56	75	1185	405T*	EM4404T	86.9	541	450,13 (332)	95	95.3	95	73	82	85	6316	6316	E1	966,72 (38.06)	416820-2	-
75	100	3565	405TS*	EM4402T-4	110	695	199,31 (147)	94.6	95.1	95	86	89	90	6313	6313	G	896,87 (35.31)	416820-8	25
75	100	1785	405T*	EM4400T	112	725	399,97 (295)	95.4	95.7	95.4	83	87	87	6316	6316	F	945,39 (37.22)	416820-2	-
75	100	1785	405T*	EM4400T-12	112	725	399,97 (295)	95.4	95.7	95.4	83	87	87	6316	6316	F	973,07 (38.31)	416820-2	25
75	100	1785	405TS*	EM4400TS	112	725	399,97 (295)	95.4	95.7	95.4	83	87	87	6316	6316	F	896,87 (35.31)	416820-2	-
75	100	1190	444T*	EM4409T-4	119	723	599,27 (442)	95	95.3	95	68	78	83	6318	6318	G	1136,65 (44.75)	416820-36	-
75	100	1190	444T*	EM4909T-4	119	723	599,27 (442)	95	95.3	95	68	78	83	6318	6318	G	1136,65 (44.75)	416820-36	99

Notes: Volt code: E = 208-230/460V, 60 Hz; E1 = 230/460V, 60 Hz, usable at 208V; F = 230/460V, 60 Hz; G = 460V, 60 Hz

* Ratings are cast iron frames.

25 = Wye start delta run 99 = Has F3 lead outlet hole and an arm mounted conduit box for easy F1 or F2 lead location.

See pages 40 through 42 for layout drawings. See pages 58 through 61 for connection diagrams.

Efficiencies shown are nominal. Data subject to change without notice. Contact your ABB regional support office for certified data.

NEMA Super-E[®] premium efficient motors

TEFC

Foot mounted



TEFC - totally enclosed fan cooled – foot mounted, 230/460, 460 & 575 volts, three phase, 0.37-149 kW (1/2 - 200 hp)

kW	Hp	RPM	Frame	Catalog number	Amps @ high V		F.L. torque Nm (lb-ft)	Efficiency %			Power factor %			Bearings		Volt code	"C" dim. mm (in)	Conn. diag. no.	Notes
					Full load	Locked rotor		1/2	3/4	Full load	1/2	3/4	Full load	DE	ODE				
230/460 & 460 Volts (continued)																			
93	125	3570	444TS*	EM4412T-4	137	873	249,47 (184)	94.9	95.5	95	81	87	89	6313	6313	G	1040,89 (40.98)	416820-36	-
93	125	3570	444TS*	EM4912T-4	137	873	249,47 (184)	94.9	95.5	95	81	87	89	6313	6313	G	1040,89 (40.98)	416820-36	99
93	125	1785	444T*	EM4410T-4	144	892	498,94 (368)	95.5	95.8	95.4	73	82	85	6318	6318	G	1136,65 (44.75)	416820-36	-
93	125	1785	444T*	EM4410T-4E	139	892	498,94 (368)	95.5	95.8	95.8	73	82	88	6318	6318	G	1133,35 (44.62)	416820-36	56
93	125	1785	444TS*	EM4410TS-4	144	892	498,94 (368)	95.5	95.8	95.4	73	82	85	6318	6318	G	1040,89 (40.98)	416820-36	-
93	125	1785	444T*	EM4910T-4	144	892	498,94 (368)	95.5	95.8	95.4	73	82	85	6318	6318	G	1136,65 (44.75)	416820-36	99
93	125	1785	444TS*	EM4910TS-4	144	892	498,94 (368)	95.5	95.8	95.4	73	82	85	6318	6318	G	1040,89 (40.98)	416820-36	99
93	125	1188	445T*	EM4411T-4	146	966	748,41 (552)	95	95.4	95	70	80	84	6318	6318	G	1136,65 (44.75)	416820-8	25
93	125	1188	445T*	EM4911T-4	146	966	748,41 (552)	95	95.4	95	70	80	84	6318	6318	G	1136,65 (44.75)	416820-8	25,99
112	150	3570	445TS*	EM4413T-4	164	1081	299,64 (221)	94.7	95.3	95	82	88	90	6313	6313	G	1040,89 (40.98)	416820-36	-
112	150	3570	445TS*	EM4913T-4	164	1081	299,64 (221)	94.7	95.3	95	82	88	90	6313	6313	G	1040,89 (40.98)	416820-36	99
112	150	1785	445T*	EM4406T-4	169	1041	599,27 (442)	96	96.1	95.8	76	83	86	6318	6318	G	1136,65 (44.75)	416820-8	25
112	150	1785	445T*	EM4406T-4E	165	1085	599,27 (442)	96.4	96.6	96.2	83	88	89	6318	6318	G	1133,35 (44.62)	416820-36	56
112	150	1785	445TS*	EM4406TS-4	169	1041	599,27 (442)	96	96.1	95.8	76	83	86	6318	6318	G	1040,89 (40.98)	416820-36	-
112	150	1785	445T*	EM4906T-4	169	1041	599,27 (442)	96	96.1	95.8	76	83	86	6318	6318	G	1136,65 (44.75)	416820-8	25,99
112	150	1785	445TS*	EM4906TS-4	169	1041	599,27 (442)	96	96.1	95.8	76	83	86	6318	6318	G	1040,89 (40.98)	416820-36	99
112	150	1190	447T*	EM44156T-4	170	1025	898,91 (663)	96.3	96.2	95.8	77	84	86	6318	6318	G	1225,30 (48.24)	416820-8	25
112	150	1190	447T*	EM49156T-4	170	1025	898,91 (663)	96.3	96.2	95.8	77	84	86	6318	6318	G	1225,30 (48.24)	416820-8	25,99
149	200	3570	447TS*	EM4416T-4	213	1426	398,61 (294)	96	96.3	95.4	84	89	91	6313	6313	G	1129,79 (44.48)	416820-36	-
149	200	3570	447TS*	EM4916T-4	213	1426	398,61 (294)	96	96.3	95.4	84	89	91	6313	6313	G	1129,79 (44.48)	416820-36	99
149	200	1785	447T*	EM4407T-4	223	1421	797,22 (588)	96.5	96.5	96.2	77	85	87	6318	6318	G	1225,30 (48.24)	416820-36	-
149	200	1785	447T*	EM4407T-4E	221	1450	798,58 (589)	96	96.3	96.2	84	88	88	6318	6318	G	1229,36 (48.4)	416820-36	56
149	200	1785	447TS*	EM4407TS-4	223	1421	797,22 (588)	96.5	96.5	96.2	77	85	87	6318	6318	G	1129,79 (44.48)	416820-36	-
149	200	1785	447T*	EM4907T-4	223	1421	797,22 (588)	96.5	96.5	96.2	77	85	87	6318	6318	G	1225,30 (48.24)	416820-36	99
149	200	1785	447TS*	EM4907TS-4	223	1421	797,22 (588)	96.5	96.5	96.2	77	85	87	6318	6318	G	1129,79 (44.48)	416820-36	99
149	200	1785	447T*	EM4407TR-4	223	1421	797,22 (588)	96.5	96.5	96.2	77	85	87	3222	6318	G	1225,30 (48.24)	416820-36	5
149	200	1785	447T*	EM4907TR-4	223	1421	797,22 (588)	96.5	96.5	96.2	77	85	87	3222	6318	G	1225,30 (48.24)	416820-36	5,99
149	200	1190	449T*	EM44206T-4	225	1404	1197,19 (883)	96.1	96.2	95.8	78	84	87	6318	6318	G	1352,30 (53.24)	416820-36	-
149	200	1190	449T*	EM49206T-4	225	1404	1197,19 (883)	96.1	96.2	95.8	78	84	87	6318	6318	G	1352,30 (53.24)	416820-36	99
575 volts																			
0,75	1	1760	143T	EM3546T-5	1.2	9.7	4,07 (3)	81.9	84.8	85.5	49	62	71	6205	6203	H	312,67 (12.31)	CD0006	-
0,75	1	1155	145T	EM3556T-5	1.4	8.6	6,10 (4.5)	79.2	82	82.5	43	56	64	6205	6203	H	338,07 (13.31)	CD0006	-
1,1	1 1/2	3450	143T	EM3550T-5	1.6	15.8	3,12 (2.3)	81.3	84.3	84	68	78	83	6205	6203	H	338,07 (13.31)	CD0006	-
1,1	1 1/2	1760	145T	EM3554T-5	1.8	14.6	6,10 (4.5)	84.5	87	86.5	51	65	74	6205	6203	H	338,07 (13.31)	CD0006	-
1,1	1 1/2	1170	182T	EM3607T-5	2.1	11.6	9,22 (6.8)	86.1	88.5	87.5	42	53	62	6206	6205	H	420,37 (16.55)	CD0006	-
1,5	2	3450	145T	EM3555T-5	2	24	4,07 (3)	83.8	86.2	85.5	70	80	85	6205	6203	H	360,43 (14.19)	CD0006	-
1,5	2	1755	145T	EM3558T-5	2.4	19.6	8,13 (6)	83.8	86.4	86.5	50	64	73	6205	6203	H	360,43 (14.19)	CD0006	-
1,5	2	1170	184T	EM3614T-5	2.8	16.5	12,20 (9)	86.8	88.7	88.5	41	54	61	6206	6205	H	458,47 (18.05)	CD0006	-
2,2	3	3475	145T	EM3559T-5	2.8	30	6,10 (4.5)	86	87	86.5	82	89	91	6205	6203	H	395,22 (15.56)	CD0006	-
2,2	3	1760	182T	EM3611T-5	3.3	25.9	12,07 (8.9)	87.7	89.5	89.5	54	67	75	6206	6205	H	420,37 (16.55)	CD0006	-
2,2	3	1755	182T*	EM3661T-5	3.3	23.8	12,34 (9.1)	88.4	89.8	89.5	59	71	77	6206	6205	H	387,10 (15.24)	CD0006	-
2,2	3	1160	213T	EM3704T-5	3.7	27.5	18,17 (13.4)	87.7	89.4	89.5	49	61	68	6307	6206	H	482,85 (19.01)	CD0006	-
3,7	5	3450	184T	EM3613T-5	4.7	45.7	10,30 (7.6)	88.4	89.1	88.5	81	88	91	6206	6205	H	420,12 (16.54)	CD0006	-
3,7	5	1750	184T	EM3615T-5	5.3	39.3	20,20 (14.9)	89.6	90.5	89.5	60	72	78	6206	6205	H	458,47 (18.05)	CD0006	-
3,7	5	1750	184T*	EM3665T-5	5.3	35.7	20,34 (15)	90.6	90.3	89.5	63	74	79	6206	6205	H	387,10 (15.24)	CD0006	-
3,7	5	1160	215T	EM3708T-5	5.8	42.4	30,78 (22.7)	89.7	90.1	89.5	54	65	72	6307	6206	H	501,90 (19.76)	CD0006	-
5,6	7 1/2	3470	184T	EM3616T-5	6.8	72.7	15,46 (11.4)	90.6	91	89.5	85	90	93	6206	6205	H	458,47 (18.05)	CD0006	-
5,6	7 1/2	3470	213T	EM3709T-5	6.9	50.5	15,05 (11.1)	89.1	90.2	89.5	80	87	90	6307	6206	H	454,41 (17.89)	CD0006	-
5,6	7 1/2	1770	213T	EM3710T-5	7.6	58.5	30,10 (22.2)	91.1	92.3	91.7	61	74	81	6307	6206	H	483,11 (19.02)	CD0006	-
5,6	7 1/2	1770	213T*	EM3770T-5	7.5	53.9	29,96 (22.1)	91.2	91.8	91.7	65	76	81	6307	6206	H	468,63 (18.45)	CD0006	-

Notes: Volt code: G = 460V, 60 Hz; H = 575V, 60 Hz

* Ratings are cast iron frames.

5 = Belted duty only, Roller bearing 25 = Wye start delta run 56 = Single frame mounting holes in 447 and 449 frame

99 = Has F3 lead outlet hole and an arm mounted conduit box for easy F1 or F2 lead location.

See pages 40 through 42 for layout drawings. See pages 58 through 61 for connection diagrams.

Efficiencies shown are nominal. Data subject to change without notice. Contact your ABB regional support office for certified data.

NEMA Super-E[®] premium efficient motors

TEFC

Foot mounted



TEFC - totally enclosed fan cooled – foot mounted, 230/460, 460 & 575 volts, three phase, 0.37-149 kW (1/2 - 200 hp)

kW	Hp	RPM	Frame	Catalog number	Amps @ high V		F.L. torque Nm (lb-ft)	Efficiency %			Power factor %			Bearings		Volt code	"C" dim. mm (in)	Conn. diag. no.	Notes
					Full load	Locked rotor		1/2	3/4	Full load	1/2	3/4	Full load	DE	ODE				
575 volts (continued)																			
7.5	10	3490	215T	EM3711T-5	9.5	62.6	20,34 (15)	91.1	91.4	90.2	74	84	87	6307	6206	H	454,41 (17.89)	CD0006	-
7.5	10	1770	215T	EM3714T-5	9.6	83.9	40,00 (29.5)	92	92.7	91.7	65	78	85	6307	6206	H	521,21 (20.52)	CD0006	-
7.5	10	1760	215T*	EM3774T-5	9.8	66.3	40,40 (29.8)	92.1	92.7	91.7	70	79	83	6307	6206	H	468,63 (18.45)	CD0006	-
11	15	3500	215T	EM3713T-5	13.6	125	30,10 (22.2)	93.2	93	91	83	90	91	6307	6206	H	521,21 (20.52)	CD0006	-
11	15	3525	254T*	EM2394T-5	14.1	91.8	29,96 (22.1)	90.8	91.8	91	75	83	86	6309	6208	H	588,26 (23.16)	CD0006	-
11	15	1765	254T*	EM2333T-5	14.8	99	60,33 (44.5)	91.3	92.5	92.4	67	78	82	6309	6208	H	588,26 (23.16)	CD0006	-
15	20	3510	256T*	EM4106T-5	18.2	120	40,54 (29.9)	92.4	92.1	91	81	87	90	6309	6208	H	588,26 (23.16)	CD0006	-
15	20	1765	256T*	EM2334T-5	19.2	140	79,99 (59)	92.8	93.1	93	69	80	84	6309	6208	H	588,26 (23.16)	CD0006	-
19	25	3520	284TS*	EM4107T-5	22	168	50,44 (37.2)	92.2	92.7	91.7	87	91	93	6311	6208	H	627,38 (24.7)	CD0006	-
19	25	1770	284T*	EM4103T-5	23.9	153	100,47 (74.1)	92.4	93.5	93.6	71	80	84	6311	6309	H	705,10 (27.76)	CD0006	-
22	30	3520	286TS*	EM4108T-5	26.5	204	60,61 (44.7)	93.1	93.1	91.7	81	88	91	6311	6208	H	627,38 (24.7)	CD0006	-
22	30	1770	286T*	EM4104T-5	29	177	120,94 (89.2)	93.9	94.4	93.6	69	77	84	6311	6309	H	705,10 (27.76)	CD0006	-
30	40	3540	324TS*	EM4109T-5	36	268	80,67 (59.5)	92.3	93.4	92.4	79	86	89	6312	6311	H	731,01 (28.78)	CD0006	-
30	40	1775	324T*	EM4110T-5	39	267	159,99 (118)	93.6	94.3	94.1	67	77	82	6312	6311	H	769,11 (30.28)	CD0006	-
37	50	3540	326TS*	EM4114T-5	45	325	100,60 (74.2)	93.6	94.3	93	79	86	89	6312	6311	H	734,06 (28.9)	CD0006	-
37	50	1775	326T*	EM4115T-5	46	310	202,02 (149)	94.4	95.1	94.5	75	83	87	6312	6311	H	769,11 (30.28)	CD0006	-
45	60	1780	364T*	EM4314T-5	54.4	344	239,98 (177)	95.2	95.3	95	79	85	87	6313	6313	H	849,38 (33.44)	416820-36	-
56	75	1780	365T*	EM4316T-5	68.7	434	299,64 (221)	95.7	95.8	95.4	77	84	86	6313	6313	H	849,38 (33.44)	416820-36	-
75	100	1785	405T*	EM4400T-5	89.6	580	399,97 (295)	95.4	95.7	95.4	83	87	88	6316	6316	H	966,72 (38.06)	416820-36	-
93	125	1785	444T*	EM4410T-5	115	713	498,94 (368)	95.5	95.8	95.4	73	82	85	6318	6318	H	1136,65 (44.75)	416820-36	-
93	125	1785	444T*	EM4410T-5E	111	726	498,94 (368)	95.5	95.9	95.8	81	87	88	6318	6318	H	1133,35 (44.62)	416820-36	56
93	125	1785	444T*	EM4910T-5	115	713	498,94 (368)	95.5	95.8	95.4	73	82	85	6318	6318	H	1136,65 (44.75)	416820-36	99
112	150	1785	445T*	EM4406T-5E	132	868	597,92 (441)	96.4	96.6	96.2	83	88	89	6318	6318	H	1133,35 (44.62)	416820-36	56
112	150	1785	445T*	EM4406T-5	136	833	599,27 (442)	96	96.1	95.8	76	83	86	6318	6318	H	1136,65 (44.75)	416820-36	-
112	150	1785	445T*	EM4906T-5	136	833	599,27 (442)	96	96.1	95.8	76	83	86	6318	6318	H	1136,65 (44.75)	416820-36	99

Notes: Volt code: H=575V, 60 Hz

* Ratings are cast iron frames.

56 = Single frame mounting holes in 447 and 449 frame

99 = Has F3 lead outlet hole and an arm mounted conduit box for easy F1 or F2 lead location.

See pages 40 through 42 for layout drawings. See pages 58 through 61 for connection diagrams.

Efficiencies shown are nominal. Data subject to change without notice. Contact your ABB regional support office for certified data.

F2 mounting



Foot mounted, 230/460 volts, three phase, 1.5-22 kW (2 - 30 hp)

kW	Hp	RPM	Frame	Catalog number	Amps @ high V		F.L. torque Nm (lb-ft)	Efficiency %			Power factor %			Bearings		Volt code	"C" dim. mm (in)	Conn. diag. no.
					Full load	Locked rotor		1/2	3/4	Full load	1/2	3/4	Full load	DE	ODE			
1,5	2	1755	145T	EFM3558T	2.9	24.3	8,13 (6)	84.2	86.4	86.5	51	64	73	6205	6203	E	360,43 (14.19)	CD0005
2,2	3	1760	182T	EFM3611T	4.2	32	12,07 (8.9)	87.8	89.5	89.5	54	68	75	6206	6205	E	420,37 (16.55)	CD0005
3,7	5	1750	184T	EFM3615T	6.7	49.1	20,20 (14.9)	89.7	90.3	89.5	60	72	78	6206	6205	E	458,72 (18.06)	CD0005
5,6	7 1/2	1770	213T	EFM3710T	9.4	71.6	30,23 (22.3)	91.8	92.4	91.7	62	75	81	6307	6206	E	482,85 (19.01)	CD0005
7,5	10	1770	215T	EFM3714T	12	103	40,00 (29.5)	92.1	92.4	91.7	66	79	85	6307	6206	E	520,95 (20.51)	CD0005
11	15	1765	254T*	EFM2333T	18.5	122.9	60,47 (44.6)	91.9	92.6	92.4	66	77	82	6309	6208	E1	588,26 (23.16)	CD0005
15	20	1765	256T*	EFM2334T	24	175.1	80,67 (59.5)	92.6	93.3	93	70	79	84	6309	6208	E1	588,26 (23.16)	CD0005
19	25	1770	284T*	EFM4103T	30	186	100,60 (74.2)	92.3	93.5	93.6	73	81	85	6311	6309	E1	705,10 (27.76)	CD0005
22	30	1770	286T*	EFM4104T	36	235	120,80 (89.1)	93.7	94.3	93.6	66	75	83	6311	6309	E1	705,10 (27.76)	CD0005

Notes: Volt code: E = 208-230/460V, 60 Hz; E1 = 230/460V, 60 Hz, usable at 208V

* Ratings are cast iron frames.

See pages 40 and 41 for layout drawings. See page 58 for connection diagrams.

Efficiencies shown are nominal. Data subject to change without notice. Contact your ABB regional support office for certified data.

NEMA Super-E[®] premium efficient motors

C-face
Foot mounted

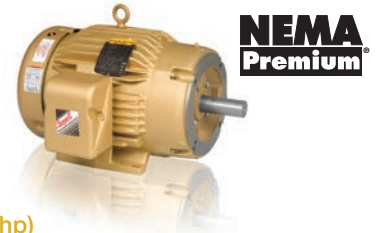

TEFC - totally enclosed fan cooled – 230/460 & 575 Volts, Three Phase, 0.75 - 75 kW (1 - 100 hp)

kW	Hp	RPM	Frame	Catalog number	Amps @ High V		F.L. torque Nm (lb-ft)	Efficiency %			Power factor %			Bearings		Volt code	"C" dim. mm (in)	Conn. diag. no.
					Full load	Locked rotor		1/2	3/4	Full load	1/2	3/4	Full load	DE	ODE			
230/460 volts																		
0,75	1	3450	56C	CEM3545	1.4	9	2,03 (1.5)	67.8	73.1	77	74	82	87	6205	6203	E1	311,15 (12.25)	CD0005
0,75	1	1760	56C	CEM3546	1.5	12.1	4,03 (2.97)	82.1	84.8	85.5	49	62	71	6205	6203	E	310,64 (12.23)	CD0005
0,75	1	1760	143TC	CEM3546T	1.5	12.1	4,07 (3)	82.1	84.8	85.5	49	62	71	6205	6203	E	337,57 (13.29)	CD0005
0,75	1	1760	143TC*	CEM3581T	1.5	12.1	4,07 (3)	82.1	84.8	85.5	79	62	71	6205	6203	E	330,96 (13.03)	CD0005
0,75	1	1155	145TC	CEM3556T	1.8	10.8	6,10 (4.5)	79.4	82.3	82.5	43	55	64	6205	6203	E	337,57 (13.29)	CD0005
1,1	1 1/2	3500	56C	CEM3550	1.9	17.9	2,98 (2.2)	82.2	84.4	84	67	79	85	6205	6203	E	336,55 (13.25)	CD0005
1,1	1 1/2	3500	143TC	CEM3550T	1.9	17.9	2,98 (2.2)	82.2	84.4	84	67	79	85	6205	6203	E	337,57 (13.29)	CD0005
1,1	1 1/2	3500	143TC*	CEM3583T	1.9	17.9	2,98 (2.2)	82	84.6	84	67	79	85	6205	6203	E	330,96 (13.03)	CD0005
1,1	1 1/2	1760	56C	CEM3554	2.2	18.3	6,10 (4.5)	84.5	86.8	86.5	51	65	73	6205	6203	E	336,04 (13.23)	CD0005
1,1	1 1/2	1760	145TC	CEM3554T	2.2	18.3	6,10 (4.5)	84.5	86.8	86.5	51	65	73	6205	6203	E	337,57 (13.29)	CD0005
1,1	1 1/2	1765	145TC*	CEM3584T	2.3	20.7	6,10 (4.5)	83.8	86.4	86.5	49	62	71	6205	6203	E	330,96 (13.03)	CD0005
1,1	1 1/2	1170	182TC	CEM3607T	2.6	14.7	9,22 (6.8)	86	88.3	87.5	42	53	62	6206	6205	E	420,37 (16.55)	CD0005
1,5	2	3490	56C	CEM3555	2.5	25.9	4,07 (3)	83.5	85.9	85.5	75	84	88	6205	6203	E	336,55 (13.25)	CD0005
1,5	2	3490	145TC	CEM3555T	2.5	25.9	4,07 (3)	83.5	85.9	85.5	75	84	88	6205	6203	E	337,57 (13.29)	CD0005
1,5	2	3490	145TC*	CEM3586T	2.5	25.9	4,07 (3)	83.5	85.9	85.5	75	84	88	6205	6203	E	330,96 (13.03)	CD0005
1,5	2	1755	56C	CEM3558	2.9	24.3	8,13 (6)	84.2	86.4	86.5	51	64	73	6205	6203	E	358,14 (14.1)	CD0005
1,5	2	1755	145TC	CEM3558T	2.9	24.3	8,13 (6)	84.2	86.4	86.5	51	64	73	6205	6203	E	359,92 (14.17)	CD0005
1,5	2	1750	145TC*	CEM3587T	2.9	25	8,13 (6)	85.1	87.1	86.5	53	66	75	6205	6203	E	330,96 (13.03)	CD0005
1,5	2	1170	184TC	CEM3614T	3.5	20.9	12,20 (9)	86.7	88.6	88.5	41	53	60	6206	6205	E	458,47 (18.05)	CD0005
1,5	2	1165	184TC*	CEM3664T	3.2	20.9	12,20 (9)	86.4	88.1	88.5	48	60	68	6206	6205	E	406,40 (16)	CD0005
2,2	3	3450	145TC	CEM3559T	3.6	33	6,10 (4.5)	87.9	88.2	86.5	81	88	92	6205	6203	E	359,92 (14.17)	CD0005
2,2	3	3450	182TC	CEM3610T	3.7	33.3	6,37 (4.7)	86.2	87.3	86.5	82	88	91	6206	6205	E	385,57 (15.18)	CD0005
2,2	3	3460	182TC*	CEM3660T	3.8	30.9	6,37 (4.7)	86.5	87.4	86.5	76	84	88	6206	6205	E	406,40 (16)	CD0005
2,2	3	1760	182TC	CEM3611T	4.2	32	12,07 (8.9)	87.8	89.5	89.5	54	68	75	6206	6205	E	420,37 (16.55)	CD0005
2,2	3	1755	182TC*	CEM3661T	4.1	29.8	12,34 (9.1)	88.9	90.1	89.5	58	70	77	6206	6205	E	406,40 (16)	CD0005
2,2	3	1160	213TC	CEM3704T	4.6	34.4	18,17 (13.4)	87.7	89.4	89.5	49	61	68	6307	6206	E	501,90 (19.76)	CD0005
2,2	3	1165	213TC*	CEM3764T	4.5	33.2	18,44 (13.6)	88.1	89.5	89.5	53	64	71	6307	6206	E	487,68 (19.2)	CD0005
3,7	5	3450	184TC	CEM3613T	5.9	57.2	10,44 (7.7)	88.9	89.4	88.5	81	88	91	6206	6205	F	420,37 (16.55)	CD0005
3,7	5	3475	184TC*	CEM3663T	6.3	51.7	10,17 (7.5)	87.8	89	88.5	64	77	84	6206	6205	E	406,40 (16)	CD0005
3,7	5	1750	184TC	CEM3615T	6.7	49.1	20,20 (14.9)	89.7	90.3	89.5	60	72	78	6206	6205	E	458,47 (18.05)	CD0005
3,7	5	1750	184TC*	CEM3665T	6.6	45.5	20,34 (15)	89.8	90.3	89.5	63	73	79	6206	6205	E	406,40 (16)	CD0005
3,7	5	1160	215TC	CEM3708T	7.3	51.6	30,78 (22.7)	89.8	90.4	89.5	55	66	73	6307	6206	E	520,95 (20.51)	CD0005
3,7	5	1160	215TC*	CEM3768T	7.4	50.6	30,51 (22.5)	89.9	90.3	89.5	54	65	71	6307	6206	E	487,68 (19.2)	CD0005
5,6	7 1/2	3450	184TC	CEM3616T	8.4	91	15,42 (11.37)	90.6	90.7	89.5	85	90	93	6206	6205	E	458,47 (18.05)	CD0005
5,6	7 1/2	3470	213TC	CEM3709T	8.6	63.1	15,05 (11.1)	89.2	90.1	89.5	80	87	90	6307	6206	E1	473,20 (18.63)	CD0005
5,6	7 1/2	3525	213TC*	CEM3769T	8.6	75	15,19 (11.2)	90	91.4	91	79	87	90	6307	6206	E1	487,68 (19.2)	CD0005
5,6	7 1/2	1770	213TC	CEM3710T	9.4	71.6	30,23 (22.3)	91.8	92.4	91.7	62	75	81	6307	6206	E	501,90 (19.76)	CD0005
5,6	7 1/2	1770	213TC*	CEM3770T	9.5	68	29,96 (22.1)	91.6	92.3	91.7	65	76	81	6307	6206	E1	487,68 (19.2)	CD0005
7,5	10	3490	215TC	CEM3711T	11.8	78.5	20,34 (15)	91	91.3	90.2	74	84	87	6307	6206	E	473,20 (18.63)	CD0005
7,5	10	3500	215TC*	CEM3771T	11.8	88.5	20,20 (14.9)	93	93.2	90.2	79	88	90	6307	6206	E1	487,68 (19.2)	CD0005
7,5	10	1770	215TC	CEM3714T	12	103	40,00 (29.5)	92.1	92.4	91.7	66	79	85	6307	6206	E	540,00 (21.26)	CD0005
7,5	10	1760	215TC*	CEM3774T	12.2	81	40,40 (29.8)	92.5	92.9	91.7	71	80	83	6307	6206	E1	487,68 (19.2)	CD0005
11	15	3500	215TC	CEM3713T	17	161	30,51 (22.5)	91.5	91.8	91	87	92	93	6307	6206	E	540,00 (21.26)	CD0005
11	15	3520	254TC*	CEM2394T	17.5	110	29,96 (22.1)	91	91.6	91	77	85	87	6309	6208	E1	604,01 (23.78)	CD0180
11	15	1765	254TC*	CEM2333T	18.5	122.9	60,47 (44.6)	91.9	92.6	92.4	66	77	82	6309	6208	E1	604,01 (23.78)	CD0005
15	20	3520	256TC*	CEM4106T	23	161	40,13 (29.6)	92.2	92.4	91	78	86	89	6309	6208	E1	604,01 (23.78)	CD0005
15	20	1765	256TC*	CEM2334T	24	175.1	80,67 (59.5)	92.6	93.3	93	70	79	84	6309	6208	E1	604,01 (23.78)	CD0005
19	25	3520	284TSC*	CEM4107T	27	206	50,44 (37.2)	92.2	92.8	91.7	87	91	93	6311	6208	E1	627,63 (24.71)	CD0180
19	25	1770	284TC*	CEM4103T	30	186	100,60 (74.2)	92.3	93.5	93.6	73	81	85	6311	6309	E1	705,10 (27.76)	CD0005
22	30	3520	284TSC*	CEM4108T	33	214	60,33 (44.5)	92.8	93.2	91.7	83	89	91	6311	6309	E	670,31 (26.39)	CD0180
22	30	1760	286TC*	CEM4104T	38	270	120,26 (88.7)	92.3	93.5	93.6	63	73	80	6311	6309	E1	705,10 (27.76)	CD0180
30	40	3530	324TSC*	CEM4109T	46	305	80,26 (59.2)	91.6	92.6	92.4	79	86	88	6312	6311	E1	731,01 (28.78)	CD0180
30	40	1775	324TC*	CEM4110T	48	338	159,99 (118)	93.5	94.2	94.1	69	78	83	6312	6311	E1	769,11 (30.28)	CD0180

Notes: Volt code: E = 208-230/460V, 60 Hz; E1 = 230/460V, 60 Hz, usable at 208V; F = 230/460V, 60 Hz

* Ratings are cast iron frames.

See pages 40 and 43 for layout drawings. See pages 58 and 60 for connection diagrams.

Efficiencies shown are nominal. Data subject to change without notice. Contact your ABB regional support office for certified data.

NEMA Super-E[®] premium efficient motors

C-face

Foot mounted



TEFC - totally enclosed fan cooled – 230/460 & 575 Volts, Three Phase, 0.75 - 75 kW (1 - 100 hp)

kW	Hp	RPM	Frame	Catalog number	Amps @ High V		F.L. torque Nm (lb-ft)	Efficiency %			Power factor %			Bearings		Volt code	"C" dim. mm (in)	Conn. diag. no.
					Full load	Locked rotor		1/2	3/4	Full load	1/2	3/4	Full load	DE	ODE			
230/460 volts (continued)																		
37	50	3540	326TSC*	CEM4114T	56	408	100,87 (74.4)	93.8	94.2	93	82	88	90	6312	6311	E1	731,01 (28.78)	CD0180
37	50	1775	326TC*	CEM4115T	57	392	202,02 (149)	94.4	94.9	94.5	73	82	85	6312	6311	E1	769,11 (30.28)	CD0180
45	60	3560	364TSC*	CEM4310T	67.3	398	119,99 (88.5)	95.3	95.5	93.6	88	91	91	6313	6313	E1	795,27 (31.31)	416820-2
45	60	1780	364TC*	CEM4314T	68	430	239,98 (177)	95.5	95.3	95	79	85	87	6313	6313	E1	849,38 (33.44)	416820-2
56	75	3555	365TSC*	CEM4313T	83.4	494	150,50 (111)	95.1	95.4	93.6	91	92	92	6313	6313	E1	795,27 (31.31)	416820-2
56	75	1780	365TC*	CEM4316T	85.9	542	299,64 (221)	95.7	95.8	95.4	77	84	86	6313	6313	E1	849,38 (33.44)	416820-2
75	100	1785	405TC*	CEM4400T	112	725	399,97 (295)	95.4	95.7	95.4	83	87	87	6316	6316	E1	973,07 (38.31)	416820-2
575 volts																		
0,75	1	1760	143TC	CEM3546T-5	1.2	9.66	4,07 (3)	81.9	84.8	85.5	49	62	71	6205	6203	H	337,57 (13.29)	CD0006
0,75	1	1760	143TC*	CEM3581T-5	1.2	9.66	4,07 (3)	81.9	84.8	85.5	49	62	71	6205	6203	H	330,96 (13.03)	CD0006
1,1	1 1/2	3500	143TC*	CEM3583T-5	1.5	14.5	2,98 (2.2)	82.1	84.3	84	66	78	85	6205	6203	H	330,96 (13.03)	CD0006
1,1	1 1/2	1760	145TC	CEM3554T-5	1.8	14.6	6,10 (4.5)	84.5	87	86.5	51	65	74	6205	6203	H	337,57 (13.29)	CD0006
1,1	1 1/2	1760	145TC*	CEM3584T-5	1.7	14.3	6,10 (4.5)	86.5	88.2	86.5	54	67	76	6205	6203	H	330,96 (13.03)	CD0006
1,5	2	3490	145TC*	CEM3586T-5	2	21	4,07 (3)	83.6	85.5	85.5	74	84	88	6205	6203	H	330,96 (13.03)	CD0006
1,5	2	1755	145TC	CEM3558T-5	2.4	19.6	8,13 (6)	83.8	86.4	86.5	50	64	73	6205	6203	H	359,92 (14.17)	CD0006
1,5	2	1750	145TC*	CEM3587T-5	2.3	20	8,13 (6)	85.2	87	86.5	53	66	74	6205	6203	H	330,96 (13.03)	CD0006
2,2	3	3450	145TC	CEM3559T-5	2.9	26.1	6,10 (4.5)	87.9	88.1	86.5	77	86	88	6205	6203	H	359,92 (14.17)	CD0006
2,2	3	3450	182TC	CEM3610T-5	2.9	26.1	6,10 (4.5)	87.9	88.1	86.5	77	86	88	6206	6203	H	385,57 (15.18)	CD0006
2,2	3	3460	182TC*	CEM3660T-5	3	20.9	6,24 (4.6)	86.3	87	86.5	74	82	87	6206	6205	H	406,40 (16)	CD0006
2,2	3	1760	182TC	CEM3611T-5	3.3	25.9	12,07 (8.9)	87.7	89.5	89.5	54	67	75	6206	6205	H	420,37 (16.55)	CD0006
2,2	3	1755	182TC*	CEM3661T-5	3.3	23.8	12,34 (9.1)	88.4	89.8	89.5	59	71	77	6206	6205	H	406,40 (16)	CD0006
3,7	5	3450	184TC	CEM3613T-5	4.7	45.7	10,30 (7.6)	88.4	89.1	88.5	81	88	91	6206	6205	H	420,37 (16.55)	CD0006
3,7	5	3475	184TC*	CEM3663T-5	5.1	41.7	10,17 (7.5)	87.7	89	88.5	63	76	83	6206	6205	H	406,40 (16)	CD0006
3,7	5	1750	184TC	CEM3615T-5	5.3	39.3	20,20 (14.9)	89.6	91.5	89.5	60	72	78	6206	6205	H	458,47 (18.05)	CD0006
3,7	5	1750	184TC*	CEM3665T-5	5.3	35.7	20,34 (15)	90.6	90.3	89.5	63	74	79	6206	6205	H	406,40 (16)	CD0006
5,6	7 1/2	3525	213TC*	CEM3769T-5	6.9	60	15,19 (11.2)	90	91.4	89.5	79	87	90	6307	6206	H	487,68 (19.2)	CD0006
5,6	7 1/2	1770	213TC	CEM3710T-5	7.6	58.5	30,10 (22.2)	91.1	92.3	91.7	61	74	81	6307	6206	H	501,90 (19.76)	CD0006
5,6	7 1/2	1770	213TC*	CEM3770T-5	7.5	53.9	29,96 (22.1)	91.2	91.8	91.7	65	76	81	6307	6206	H	487,68 (19.2)	CD0006
7,5	10	3490	215TC	CEM3711T-5	9.5	62.6	20,34 (15)	91.1	91.4	90.2	74	84	87	6307	6206	H	473,20 (18.63)	CD0006
7,5	10	3500	215TC*	CEM3771T-5	9.3	69.3	20,20 (14.9)	92.4	92.8	90.2	80	88	91	6307	6206	H	487,68 (19.2)	CD0006
7,5	10	3490	215TC	CEM3714T-5	9.6	92.6	20,34 (15)	91.1	91.4	91.7	74	84	87	6307	6206	H	540,00 (21.26)	CD0006
7,5	10	1760	215TC*	CEM3774T-5	9.8	66.3	40,40 (29.8)	92.1	92.7	91.7	70	79	83	6307	6206	H	487,68 (19.2)	CD0006
11	15	3500	215TC	CEM3713T-5	13.6	125	30,10 (22.2)	93.2	93	91	83	90	91	6307	6206	H	540,00 (21.26)	CD0006
11	15	1765	254TC*	CEM2333T-5	14.8	99	60,33 (44.5)	91.3	92.5	92.4	67	78	82	6309	6208	H	604,01 (23.78)	CD0006
15	20	1765	256TC*	CEM2334T-5	19	138	79,99 (59)	92	93	93	67	77	84	6309	6208	H	604,01 (23.78)	CD0006
19	25	1770	284TC*	CEM4103T-5	23.9	153	100,47 (74.1)	92.4	93.5	93.6	71	80	84	6311	6309	H	705,10 (27.76)	CD0006
22	30	1765	286TC*	CEM4104T-5	28	172	120,94 (89.2)	92.8	93.6	93.6	75	83	87	6311	6309	H	705,10 (27.76)	CD0006

Notes: Volt code: E1 = 230/460V, 60 Hz, usable at 208V; H=575V, 60 Hz

* Ratings are cast iron frames.

See pages 40 and 43 for layout drawings. See pages 58 and 60 for connection diagrams.

Efficiencies shown are nominal. Data subject to change without notice. Contact your regional ABB support office for certified data.

NEMA Super-E[®] premium efficient motors

C-face
Footless



TEFC - totally enclosed fan cooled, TENV –

Totally enclosed non-ventilated – 230/460 & 575 volts, three phase, 0.18 - 15 kW (1/4 - 20 hp)

kW	Hp	RPM	Frame	Encl.	Catalog number	Amps @ high V		F.L. torque Nm (lb-ft)	Efficiency %			Power factor %			Bearings		Volt code	"C" dim. mm (in)	Conn. diag. no.
						Full load	Locked rotor		1/2	3/4	Full load	1/2	3/4	Full load	DE	ODE			
230/460 volts																			
0,18	1/4	1750	56C	TENV	KENM3454	0.4	3	1,02 (0.75)	71.2	76.9	80	52	64	73	6205	6203	F	281,18 (11.07)	CD0005
0,25	1/3	1750	56C	TENV	KENM3534	0.6	3.53	1,40 (1.03)	75.5	78.8	80	43	54	64	6205	6203	F	281,18 (11.07)	CD0005
0,25	1/3	1150	56C	TENV	KENM3535	0.6	3.33	6,10 (4.5)	77.7	80.7	81.5	50	61	69	6205	6203	E1	281,18 (11.07)	CD0005
0,37	1/2	1735	56C	TEFC	VENM3538	0.8	5.6	2,03 (1.5)	80.3	82.5	82.5	52	65	74	6205	6203	E1	310,90 (12.24)	CD0005
0,37	1/2	1765	56C	TENV	VENM3538	0.9	7.5	2,03 (1.5)	77.9	81.9	84	41	54	64	6205	6203	F	280,92 (11.06)	CD0005
0,56	3/4	1750	56C	TEFC	VENM3542	1.1	9.7	2,98 (2.2)	80.9	83.8	84	50	64	73	6205	6203	E1	310,90 (12.24)	CD0005
0,56	3/4	1750	56C	TENV	VENM3542	1.1	9.7	2,98 (2.2)	80.3	83.8	84	49	63	72	6205	6203	E1	281,18 (11.07)	CD0005
0,75	1	3450	56C	TEFC	VENM3545	1.4	9	2,03 (1.5)	67.8	73.1	77	74	82	87	6205	6203	F	310,90 (12.24)	CD0005
0,75	1	1760	56C	TEFC	VENM3546	1.5	12.1	4,07 (3)	82.1	84.8	85.5	49	62	71	6205	6203	E	310,64 (12.23)	CD0005
0,75	1	1760	56C*	TEFC	VENM3581	1.5	12.1	4,07 (3)	82.1	84.8	85.5	49	62	71	6205	6203	E	316,74 (12.47)	CD0005
0,75	1	1760	143TC	TEFC	VENM3546T	1.5	12.1	4,07 (3)	82.1	84.8	85.5	49	62	71	6205	6203	E	312,17 (12.29)	CD0005
0,75	1	1760	143TC*	TEFC	VENM3581T	1.5	12.1	4,07 (3)	82.1	84.8	85.5	49	62	71	6205	6203	E	330,96 (13.03)	CD0005
0,75	1	1745	143TC	TENV	VENM3546T	1.5	13.5	4,07 (3)	83.4	85.4	85.5	53	67	76	6205	6203	E	307,85 (12.12)	CD0005
0,75	1	1745	143TC*	TENV	VENM3581T	1.5	13.5	4,07 (3)	83.4	85.4	85.5	53	67	76	6205	6203	E	288,54 (11.36)	CD0005
0,75	1	1155	56C	TEFC	VENM3556	1.8	10.8	6,10 (4.5)	79.4	82.3	82.5	43	55	64	6205	6203	E	336,30 (13.24)	CD0005
1,1	1 1/2	3500	56C	TEFC	VENM3550	1.9	17.9	2,98 (2.2)	82.2	84.4	84	67	79	85	6205	6203	E	310,64 (12.23)	CD0005
1,1	1 1/2	1760	56C	TEFC	VENM3554	2.2	18.3	6,10 (4.5)	84.5	86.8	86.5	51	65	73	6205	6203	E	336,30 (13.24)	CD0005
1,1	1 1/2	1760	145TC	TEFC	VENM3554T	2.2	18.3	6,10 (4.5)	84.5	86.8	86.5	51	65	73	6205	6203	E	337,57 (13.29)	CD0005
1,1	1 1/2	1765	145TC*	TEFC	VENM3584T	2.3	20.7	6,10 (4.5)	83.8	86.4	86.5	49	62	71	6205	6203	E	330,96 (13.03)	CD0005
1,5	2	3490	56C	TEFC	VENM3555	2.5	25.9	4,07 (3)	83.5	85.9	85.5	75	84	88	6205	6203	E	336,30 (13.24)	CD0005
1,5	2	1755	56C	TEFC	VENM3558	2.9	24.3	8,13 (6)	84.2	86.4	86.5	51	64	73	6205	6203	E	358,65 (14.12)	CD0005
1,5	2	1755	145TC	TEFC	VENM358T	2.9	24.3	8,13 (6)	84.2	86.4	86.5	51	64	73	6205	6203	E	359,92 (14.17)	CD0005
1,5	2	1750	145TC*	TEFC	VENM3587T	2.9	25	8,13 (6)	85.1	87.1	86.5	53	66	75	6205	6203	E	330,96 (13.03)	CD0005
2,2	3	3450	182TC	TEFC	VENM3610T	3.7	33.3	6,37 (4.7)	86.2	87.3	86.5	82	88	91	6206	6205	F	385,57 (15.18)	CD0005
2,2	3	1760	182TC	TEFC	VENM3611T	4.2	32	12,07 (8.9)	87.8	89.5	89.5	54	68	75	6206	6205	E	420,37 (16.55)	CD0005
2,2	3	1755	182TC*	TEFC	VENM3661T	4.1	29.8	12,34 (9.1)	88.9	90.1	89.5	58	70	77	6206	6205	E	406,40 (16)	CD0005
3,7	5	3450	184TC	TEFC	VENM3613T	5.9	57.2	10,44 (7.7)	88.9	89.4	88.5	81	88	91	6206	6205	F	420,37 (16.55)	CD0005
3,7	5	1750	184TC	TEFC	VENM3615T	6.7	49.1	20,20 (14.9)	89.7	90.3	89.5	60	72	78	6206	6205	E	458,47 (18.05)	CD0005
3,7	5	1750	184TC*	TEFC	VENM3665T	6.6	45.5	20,34 (15)	89.8	90.3	89.5	63	73	79	6206	6205	E	406,40 (16)	CD0005
5,6	7 1/2	1770	213TC	TEFC	VENM3710T	9.4	71.6	30,23 (22.3)	91.8	92.4	91.7	62	75	81	6307	6206	E	501,90 (19.76)	CD0005
5,6	7 1/2	1770	213TC*	TEFC	VENM3770T	9.5	68	29,96 (22.1)	91.6	92.3	91.7	65	76	81	6307	6206	E1	488,95 (19.25)	CD0005
7,5	10	1770	215TC	TEFC	VENM3714T	12	103	40,00 (29.5)	92.1	92.4	91.7	66	79	85	6307	6206	E	540,00 (21.26)	CD0005
7,5	10	1760	215TC*	TEFC	VENM3774T	12.2	81	40,40 (29.8)	92.5	92.9	91.7	71	80	83	6307	6206	E1	488,95 (19.25)	CD0005
575 volts																			
0,75	1	1760	56C	TEFC	VENM3546-5	1.2	9.7	4,07 (3)	81.9	84.8	85.5	49	62	71	6205	6203	H	310,64 (12.23)	CD0006
0,75	1	1760	143TC	TEFC	VENM3546T-5	1.2	9.7	4,07 (3)	81.9	84.8	85.5	49	62	71	6205	6203	H	312,17 (12.29)	CD0006
0,75	1	1760	143TC*	TEFC	VENM3581T-5	1.2	9.7	4,07 (3)	81.9	84.8	85.5	49	62	71	6205	6203	H	330,96 (13.03)	CD0006
1,1	1 1/2	3500	143TC	TEFC	VENM3550T-5	1.5	14.5	2,98 (2.2)	82.1	84.3	84	66	78	85	6205	6203	H	312,17 (12.29)	CD0006
1,1	1 1/2	1760	145TC	TEFC	VENM3554T-5	1.8	14.6	6,10 (4.5)	84.5	87	86.5	51	65	74	6205	6203	H	337,57 (13.29)	CD0006
1,1	1 1/2	1760	145TC*	TEFC	VENM3584T-5	1.7	14.3	6,10 (4.5)	86.5	88.2	86.5	54	67	76	6205	6203	H	330,96 (13.03)	CD0006
1,5	2	1755	145TC	TEFC	VENM3558T-5	2.4	19.6	8,13 (6)	83.8	86.4	86.5	50	64	73	6205	6203	H	359,92 (14.17)	CD0006
1,5	2	1750	143TC*	TEFC	VENM3587T-5	2.3	20	8,13 (6)	85.2	87	86.5	53	66	74	6205	6203	H	330,96 (13.03)	CD0006
2,2	3	3450	182TC	TEFC	VENM3610T-5	2.9	26.6	6,37 (4.7)	86	87.4	86.5	82	88	91	6206	6205	H	385,57 (15.18)	CD0006
2,2	3	1760	182TC	TEFC	VENM3611T-5	3.3	25.9	12,07 (8.9)	87.7	89.5	89.5	54	67	75	6206	6205	H	420,37 (16.55)	CD0006
2,2	3	1755	182TC*	TEFC	VENM3661T-5	3.3	23.8	12,34 (9.1)	88.4	89.8	89.5	59	71	77	6206	6205	H	406,40 (16)	CD0006
3,7	5	3450	182TC	TEFC	VENM3613T-5	4.7	45.7	10,30 (7.6)	88.4	89.1	88.5	81	88	91	6206	6205	H	420,37 (16.55)	CD0006
3,7	5	1750	184TC	TEFC	VENM3615T-5	5.3	39.3	20,20 (14.9)	89.6	90.5	89.5	60	72	78	6206	6205	H	458,47 (18.05)	CD0006
3,7	5	1750	184TC*	TEFC	VENM3665T-5	5.3	35.7	20,34 (15)	90.6	90.3	89.5	63	74	79	6206	6205	H	406,40 (16)	CD0006
5,6	7 1/2	3470	213TC	TEFC	VENM3709T-5	6.8	72.7	15,46 (11.4)	90.6	91	89.5	85	90	93	6307	6205	H	489,71 (19.28)	CD0006
5,6	7 1/2	1770	213TC	TEFC	VENM3710T-5	7.6	58.5	30,10 (22.2)	91.1	92.3	91.7	61	74	81	6307	6206	H	501,90 (19.76)	CD0006
5,6	7 1/2	1770	213TC*	TEFC	VENM3770T-5	7.5	53.9	29,96 (22.1)	91.2	91.8	91.7	65	76	81	6307	6206	H	488,95 (19.25)	CD0006
7,5	10	3490	215TC	TEFC	VENM3711T-5	9.5	62.6	20,34 (15)	91.1	91.4	90.2	74	84	87	6307	6206	H	473,20 (18.63)	CD0006
7,5	10	1770	215TC	TEFC	VENM3714T-5	9.6	83.9	40,00 (29.5)	92	92.7	91.7	65	78	85	6307	6206	H	540,00 (21.26)	CD0006
7,5	10	1760	215TC*	TEFC	VENM3774T-5	9.8	66.3	40,40 (29.8)	92.1	92.7	91.7	70	79	83	6307	6206	H	488,95 (19.25)	CD0006
11	15	3500	215TC	TEFC	VENM3713T-5	13.6	125	30,10 (22.2)	93.2	93	91	83	90	91	6307	6206	H	540,00 (21.26)	CD0006
11	15	1765	254TC*	TEFC	VENM2333T-5	14.8	99	60,33 (44.5)	91.3	92.5	92.4	67	78	82	6309	6208	H	600,96 (23.66)	CD0006
15	20	1765	256TC*	TEFC	VENM2334T-5	19.2	140	79,99 (59)	92.8	93.1	93	69	80	84	6309	6208	H	600,96 (23.66)	CD0006

Notes: Volt code: E = 208-230/460V, 60 Hz; E1 = 230/460V, 60 Hz, usable at 208V; F = 230/460V, 60 Hz; H=575V, 60 Hz

* Ratings are cast iron frames.

See pages 40 and 44 for layout drawings. See page 58 for connection diagrams.

Efficiencies shown are nominal. Data subject to change without notice. Contact your ABB regional support office for certified data.

NEMA Super-E[®] premium efficient motors

Open drip proof (ODP)

Motor design features



Baldor•Reliance[®] Super-E[®] ODP (open drip proof) motors meet or exceed NEMA Premium[®] efficiency for applications where an open motor may be used. The “drip proof” construction provides some protection from the environment, but is best for relatively clean, weather-protected applications. Air circulates freely through the motor for cooling. These motors are available from stock in single or three phase, rigid base, C-face or close-coupled pump mountings.



Super-E ODP premium efficiency motor family

Electrical features	ODP 56T-449T frames
kW (hp) range - stock	0.75 - 224 (1 - 300)
kW (hp) range - custom	0.75 - 300 (1 - 400)
Class F insulation with Class B rise	S
1.15 service factor	S
200°C Inverter spike resistant insulation system	S
Phase insulation	S
Corona inception testing - meets NEMA Part 31.4.4.2	S
Varnish dip & bake with 100% solids	S
VPI with 2-part epoxy varnish with 100% solids	O
No silicon lead wire	S
Short commercial test (no-load amps, speed, balance and hi-pot test per NEMA MG 1-1998)	S
Standard test with data sheet supplied with motor (balance, winding resistance, no load & full load amps and speed, power factor, torque and actor, torque and hi-pot test per NEMA)	O

Mechanical features	ODP 56T-449T frames
NEMA frame sizes	143T - 447T frames
Steel band with die cast aluminum endplates	143T - 365T frames
Steel band with cast iron endplates	404 - 405T frames
Cast iron frame - cast iron endplates	365T - 449T frames optional
Cast aluminum conduit box	143T - 365T frames
Cast iron conduit box	404 - 449T
Hardware - zinc plated (140T-449T frames)	S
Motor unfiltered vibration at rated voltage and frequency <0.15 in/sec. peak velocity	S
Grease inlet with fitting	S
Grease outlet with pressure relief	143T - 215T
Grease outlet with screw-in plug	254T - 449T
Castings coated with 2-part epoxy primer	O
Finish paint with Super-E gold enamel	S
Finish paint with 2-part dark gray epoxy	O
Laser etched aluminum nameplate with NEMA data	S
Embossed stainless steel nameplate with NEMA data	O
Limited warranty	3 years

Notes: WP11 motors are available in 5000 frame and large.

S = Standard, O = Optional

Approvals: All NEMA 143T through 445T, equivalent IEC frame motors are listed under UL recognized component file # E46145.

NEMA 143T through 449T are listed under CSA recognized component file # LR2262.

NEMA Super-E[®] premium efficient motors

Open enclosure capabilities

Three phase

Typical frame size / speed - RPM

kW	hp	3600		1800		1200		900
0.75	1	56	◆	143T	◆	145T	◆	182T
1.12	1 1/2	143T	◆	145T	◆	182T	◆	184T
1.5	2	145T	◆	145T	◆	184T	◆	213T
2.2	3	145T	◆	182T	◆	213T	◆	215T
4	5	182T	◆	184T	◆	215T	◆	254T
5.6	7 1/2	184T	◆	213T	◆	254T	◆	256T
7.5	10	213T	◆	215T	◆	256T	◆	284T
11	15	215T	◆	254T	◆	284T	◆	286T
15	20	254T	◆	256T	◆	286T	◆	324T
18.7	25	256T	◆	284T	◆	324T	◆	326T
22.4	30	284T	◆	286T	◆	326T	◆	364T
29	40	286T	◆	324T	◆	364T	◆	365T
37	50	324T	◆	326T	◆	365T	◆	404T
44	60	326T	◆	364T	◆	404T	◆	405T
56	75	364T	◆	365T	◆	405T	◆	444T
75	100	365T	◆	404T	◆	444T	◆	445T
93	125	404T	◆	405T	◆	445T	◆	447T
112	150	405TS, 444TS or 449TS	◆	444T or 449T	◆	445T	◆	449T
149	200	444TS or 449TS	◆	445T or 449T	◆	445T or 449T	◆	-
187	250	445TS or 449TS	◆	445T or 449T	◆	-	◆	-
224	300	445TS or 449TS	◆	445T	◆	-	◆	-
261	350	445TS or 449TS	◆	447T or 449T	◆	-	◆	-
298	400	449TS	◆	449T	◆	-	◆	-
336	450	449TS	◆	449T	◆	-	◆	-

Notes: ◆ Denotes product scope of NEMA Premium[®] efficiency motor program.
See performance data for voltage and frame availability.

NEMA Super-E[®] premium efficient motors

Open drip proof

Foot mounted

Baldor•Reliance[®] Super-E[®] open drip proof (ODP) motors meet or exceed NEMA Premium[®] efficiency in your choice of steel-band or cast iron frame, ideal for general purpose industrial applications. The ODP enclosure allows air to pass freely through the motor for excellent heat transfer out of the windings. Class F insulation, a 1.15 service factor and Mobil Polyrex[®] EM grease are some of these motors' standard features. Super-E motors have an insulation system that meets the requirements of NEMA MG1 part 31.4.4.2 for VFD use and are considered inverter ready.

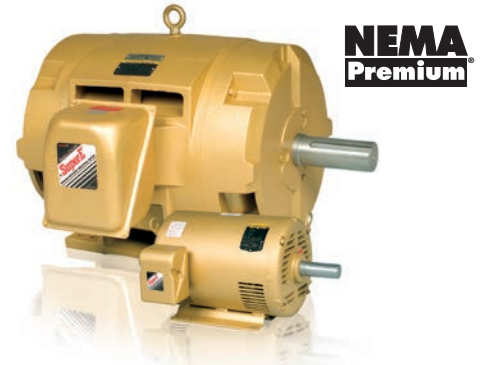

ODP – open drip proof, foot mounted, 230/460, 460 & 575 volts, three phase, 0.75 - 224 kW (1 - 300 hp)

kW	Hp	RPM	Frame	Catalog number	Amps @ high V		F.L. torque Nm (lb-ft)	Efficiency %			Power factor %			Bearings		Volt code	"C" dim. mm (in)	Conn. diag. no.	Notes
					Full load	Locked rotor		1/2	3/4	Full load	1/2	3/4	Full load	DE	ODE				
230/460 & 460 volts																			
0.75	1	3500	56	EM3115	1.5	10.8	2,03 (1.5)	74.9	79	80	59	72	80	6205	6203	E	280,92 (11.06)	CD0005	-
0.75	1	1760	143T	EM3116T	1.5	12.1	4,07 (3)	82.1	84.8	85.5	49	62	71	6205	6203	E	282,45 (11.12)	CD0005	-
0.75	1	1155	145T	EM3156T	1.8	9.8	6,10 (4.5)	80.6	83	82.5	44	56	64	6205	6203	E	295,15 (11.62)	CD0005	-
1.1	1 1/2	3490	143T	EM3120T	2	17.2	3,12 (2.3)	82.2	84.7	84	64	76	83	6205	6203	E	282,45 (11.12)	CD0005	-
1.1	1 1/2	1755	145T	EM3154T	2.2	17.5	6,10 (4.5)	83.5	86	86.5	50	63	72	6205	6203	E1	295,15 (11.62)	CD0005	-
1.1	1 1/2	1170	182T	EM3207T	2.6	14	9,22 (6.8)	84.7	87.2	87.5	41	53	62	6206	6205	E	381,00 (15)	CD0005	-
1.5	2	3450	143T	EM3155T	2.5	21.5	4,07 (3)	85.2	86.8	85.5	72	82	87	6205	6203	E	295,15 (11.62)	CD0005	-
1.5	2	1755	145T	EM3157TA	2.9	24.8	8,13 (6)	84.9	87.2	86.5	54	67	73	6205	6203	E	308,10 (12.13)	CD0007	-
1.5	2	1750	145T	EM3157T	2.9	24.3	8,13 (6)	84.4	86.6	86.5	51	64	73	6205	6203	E1	307,85 (12.12)	CD0005	-
1.5	2	1170	184T	EM3215T	3.5	19.8	12,07 (8.9)	86	88.3	88.5	40	52	60	6206	6205	E	419,10 (16.5)	CD0005	-
2.2	3	3450	145T	EM3158T	3.8	32.5	6,10 (4.5)	83.8	85.4	85.5	72	82	87	6205	6203	E1	330,20 (13)	CD0005	-
2.2	3	1765	182T	EM3211T	4.2	32.3	12,07 (8.9)	87.5	89.5	89.5	53	66	73	6206	6205	E1	381,00 (15)	CD0005	-
2.2	3	1760	182T	EM3211TA	4.4	31.3	12,07 (8.9)	88.6	89.9	89.5	53	67	75	6206	6205	E	381,00 (15)	CD0007	-
2.2	3	1160	213T	EM3305T	4.4	26.6	18,44 (13.6)	88.1	89.1	88.5	54	66	72	6307	6206	E1	414,53 (16.32)	CD0005	-
3.7	5	3450	182T	EM3212T	6	50.7	10,44 (7.7)	86.7	87.6	86.5	81	88	91	6206	6205	E	345,95 (13.62)	CD0005	-
3.7	5	1750	184T	EM3218T	6.6	44.8	20,34 (15)	89.7	90.2	89.5	64	75	80	6206	6205	E	419,10 (16.5)	CD0005	-
3.7	5	1750	184T	EM3218TA	6.6	44.8	20,34 (15)	89.8	90.2	89.5	63	75	80	6206	6205	E	419,10 (16.5)	CD0007	-
3.7	5	1160	215T	EM3309T	7.4	53	30,51 (22.5)	89.7	90.1	89.5	53	65	71	6307	6206	E	443,23 (17.45)	CD0005	-
5.6	7 1/2	3450	184T	EM3219T	8.6	86.3	15,32 (11.3)	88.1	89.2	88.5	80	87	91	6206	6205	E	381,00 (15)	CD0005	-
5.6	7 1/2	1770	213T	EM3311T	9.7	68.2	29,96 (22.1)	90.5	91.4	91	62	73	79	6307	6206	E	414,53 (16.32)	CD0005	-
5.6	7 1/2	1180	254T	EM2506T	11	62.8	44,88 (33.1)	88.6	90.4	90.2	52	63	70	6309	6208	E1	589,03 (23.19)	CD0005	-
7.5	10	3500	213T	EM3312T	11.4	98	20,34 (15)	90.9	92	91.7	81	87	90	6307	6206	E	443,23 (17.45)	CD0005	-
7.5	10	1770	215T	EM3313T	12.5	88.3	40,27 (29.7)	91.6	92.3	91.7	66	77	82	6307	6206	E1	443,23 (17.45)	CD0005	-
7.5	10	1180	256T	EM2511T	14.3	91.8	60,20 (44.4)	91	92	91.7	54	65	71	6309	6208	E1	589,03 (23.19)	CD0180	-
11	15	3525	215T	EM3314T	17.5	250	30,64 (22.6)	92.4	91.9	90.2	88	92	92	6307	6206	E1	414,53 (16.32)	CD0005	-
11	15	1765	254T	EM2513T	17.7	118	60,47 (44.6)	93.3	93.5	93	70	81	86	6309	6208	E1	550,93 (21.69)	CD0180	-
11	15	1765	254T*	EM2513T-CI	17.8	115	60,47 (44.6)	93.1	93.4	93	70	81	85	6309	6208	E1	524,00 (20.63)	CD0180	-
11	15	1180	284T	EM2524T	20.5	116	90,57 (66.8)	90.7	91.8	91.7	58	69	75	6311	6309	E1	604,77 (23.81)	CD0005	-
15	20	3510	254T	EM2514T	23.5	153	40,13 (29.6)	90.1	91.2	91	74	83	87	6309	6208	E1	550,93 (21.69)	CD0180	-
15	20	1765	256T	EM2515T	23.5	160.8	80,54 (59.4)	92.5	93.2	93	71	81	86	6309	6208	E1	550,93 (21.69)	CD0180	-
15	20	1765	256T	EM2515T-12	23.5	160.8	80,54 (59.4)	92.5	93.2	93	71	81	86	6309	6208	E1	550,93 (21.69)	CD0104	25
15	20	1765	256T*	EM2515T-CI	24	164	81,35 (60)	91.9	92.8	93	74	83	87	6309	6208	E1	568,45 (22.38)	CD0005	-
15	20	1180	286T	EM2528T	27	165.4	119,45 (88.1)	92.7	93.3	92.4	59	72	77	6311	6309	E1	604,77 (23.81)	CD0180	-
19	25	3515	256T	EM2516T	28	197	50,44 (37.2)	91.8	92.3	91.7	79	86	89	6309	6208	E1	550,93 (21.69)	CD0180	-
19	25	1760	284T	EM2531T	29	180	100,33 (74)	93.2	93.9	93.6	72	82	86	6311	6309	E1	604,77 (23.81)	CD0180	-
19	25	1770	284T	EM2531T-12	29	180	100,33 (74)	93.2	93.9	93.6	72	82	86	6311	6309	E1	604,77 (23.81)	CD0104	25
19	25	1770	284T*	EM2531T-CI	31	189	100,87 (74.4)	92.6	93.6	93.6	66	77	81	6310	6309	E1	595,38 (23.44)	CD0005	-
19	25	1180	324T	EM2532T	34	236	150,50 (111)	92.3	93.2	93	57	69	76	6312	6309	E	703,33 (27.69)	CD0180	-
22	30	3530	284TS	EM2534T	35	205	60,61 (44.7)	91.3	91.9	91.7	79	86	88	6311	6309	E	569,98 (22.44)	CD0180	-
22	30	1770	286T	EM2535T	35	223.6	120,53 (88.9)	93.6	94.2	94.1	72	82	85	6311	6309	E1	636,52 (25.06)	CD0005	-
22	30	1770	286T	EM2535T-12	35	223.6	120,53 (88.9)	93.6	94.2	94.1	72	82	85	6311	6309	E1	636,52 (25.06)	CD0104	25
22	30	1770	286T*	EM2535T-CI	35	210	120,67 (89)	93.8	94.2	94.1	75	84	86	6310	6309	E1	633,48 (24.94)	CD0180	-
22	30	1180	326T	EM2536T	38	245.6	178,97 (132)	93.4	93.8	93.6	65	75	80	6312	6309	E1	728,73 (28.69)	CD0005	-
30	40	3530	286TS	EM2538T	46	282	80,81 (59.6)	93.7	93.7	92.4	82	88	89	6311	6309	E	569,98 (22.44)	CD0180	-
30	40	3540	286TS*	EM2538T-CI	45	331	81,21 (59.9)	96.1	95.8	94.1	78	85	88	6310	6309	E	598,68 (23.57)	CD0180	-
30	40	1770	324T	EM2539T	49	330	161,34 (119)	94	94.5	94.1	65	76	82	6312	6309	E1	690,63 (27.19)	CD0005	-
30	40	1770	324T	EM2539T-12	47	316	161,34 (119)	94.6	94.8	94.1	68	79	84	6312	6309	E1	690,63 (27.19)	CD0104	25
30	40	1775	324T*	EM2539T-CI	46	313	159,99 (118)	94.2	94.8	94.5	72	82	86	6311	6311	E1	663,70 (26.13)	CD0180	-
30	40	1180	364T	EM2540T	51	337	241,34 (178)	93.1	94.1	94.1	64	74	79	6313	6311	E1	757,17 (29.81)	CD0005	-
30	40	1190	364T*	EM2540T-CI	49.4	290	239,98 (177)	93.2	94.1	94.1	69	77	81	6313	6313	E1	754,38 (29.7)	416820-2	-

Notes: Volt code: E = 208-230/460V, 60 Hz; E1 = 230/460V, 60 Hz, usable at 208V

25 = Wye start delta run

* Ratings are cast iron frames.

See pages 45 and 46 for layout drawings. See pages 58 through 60 for connection diagrams.

Efficiencies shown are nominal. Data subject to change without notice. Contact your ABB regional support office for certified data.

NEMA Super-E[®] premium efficient motors

Open drip proof

Foot mounted

ODP – open drip proof, foot mounted, 230/460, 460 & 575 volts, three phase, 0.75 - 224 kW (1 - 300 hp)

kW	Hp	RPM	Frame	Catalog number	Amps @ high V		F.L. torque Nm (lb-ft)	Efficiency %			Power factor %			Bearings		Volt code	"C" dim. mm (in)	Conn. diag. no.	Notes
					Full load	Locked rotor		1/2	3/4	Full load	1/2	3/4	Full load	DE	ODE				
230/460 & 460 volts (continued)																			
37	50	3525	324TS	EM2542T	56	376	101,28 (74.7)	94.4	94.1	93	83	88	90	6312	6309	E	652,53 (25.69)	CD0180	-
37	50	3540	324TS*	EM2542T-CI	56	383	100,47 (74.1)	93.7	94.2	93	80	86	89	6311	6311	E	625,35 (24.62)	CD0180	-
37	50	1775	326T	EM2543T	57	378	200,66 (148)	94.5	94.9	94.5	75	84	87	6312	6311	E1	703,33 (27.69)	CD0180	-
37	50	1775	326T	EM2543T-12	61	422	200,66 (148)	93.5	94.4	94.5	67	77	82	6312	6311	E1	703,33 (27.69)	CD0104	25
37	50	1775	326T*	EM2543T-CI	57	379	200,66 (148)	94.5	94.7	94.5	74	83	86	6311	6311	E1	701,80 (27.63)	CD0180	-
37	50	1775	326TS	EM2543TS-12	61	422	200,66 (148)	93.5	94.4	94.5	67	77	82	6312	6311	E1	665,23 (26.19)	CD0104	25
37	50	1185	365T	EM2544T	62	391	299,64 (221)	93.7	94.7	94.1	67	76	79	6313	6312	E1	856,49 (33.72)	CD0180	-
37	50	1185	365T*	EM2544T-CI	60.3	353	300,99 (222)	94.3	94.5	94.1	68	78	83	6313	6313	F	754,38 (29.7)	416820-2	-
45	60	3540	326TS	EM2546T	68	465	121,21 (89.4)	93.6	94	93.6	85	89	91	6312	6311	F	639,83 (25.19)	CD0180	-
45	60	1775	364T	EM2547T	68	470	239,98 (177)	94.9	95.3	95	77	85	87	6313	6311	E1	779,53 (30.69)	CD0180	-
45	60	1775	364T	EM2547T-12	68	470	239,98 (177)	94.9	95.3	95	77	85	87	6313	6311	E1	779,53 (30.69)	CD0104	25
45	60	1780	364T*	EM2547T-CI	69.5	435	239,98 (177)	95.1	95.3	95	73	82	85	6313	6313	F	754,38 (29.7)	416820-2	-
45	60	1775	364TS	EM2547TS-12	68	470	239,98 (177)	94.9	95.3	95	77	85	87	6313	6311	E1	725,42 (28.56)	CD0104	25
45	60	1185	404T	EM2548T	76	520	360,65 (266)	94.3	94.8	94.5	63	74	79	6316	6312	F	754,13 (29.69)	CD0180	-
45	60	1185	404T*	EM2548T-4CI	70.4	425	360,65 (266)	94.4	94.8	95	72	81	84	6316	6316	G	863,60 (34)	416820-8	-
56	75	3540	364TS	EM2549T	82	556	150,50 (111)	95.1	95	93.6	86	90	91	6313	6311	F	655,57 (25.81)	CD0180	-
56	75	1775	365T	EM2551T	87	512	300,99 (222)	95.5	95.7	95	78	84	87	6313	6312	E1	856,49 (33.72)	CD0180	-
56	75	1775	365T	EM2551T-12	85	512	300,99 (222)	95.5	96	95	77	83	87	6313	6312	F	856,49 (33.72)	CD0104	25
56	75	1780	365T*	EM2551T-CI	86.5	536	299,64 (221)	95.3	95.4	95	74	82	86	6313	6313	F	754,13 (29.69)	416820-2	-
56	75	1775	365TS	EM2551TS-12	85	512	300,99 (222)	95.5	96	95	77	83	87	6313	6312	F	802,39 (31.59)	CD0104	25
56	75	1185	405T*	EM2552T-4	86.9	541	450,13 (332)	95	95.3	95	73	82	85	6316	6316	G	863,60 (34)	416820-8	25
75	100	3540	365TS	EM2550T	109	748	200,66 (148)	95.1	95	94.5	86	90	91	6313	6311	F	680,97 (26.81)	CD0180	-
75	100	1780	404T	EM2555T	118	852	399,97 (295)	95.3	95.7	95.4	70	79	83	6316	6312	F	875,54 (34.47)	CD0180	-
75	100	1780	404T	EM2555T-12	118	852	399,97 (295)	95.3	95.7	95.4	70	79	83	6316	6312	F	939,04 (36.97)	CD0104	25
75	100	1780	404T	EM2555T-4	115	765	399,97 (295)	95.4	95.8	95.4	73	82	85	6316	6312	G	939,04 (36.97)	CD0382	25
75	100	1785	404T*	EM2555T-CI	115	725	398,61 (294)	95.4	95.7	95.4	74	82	85	6316	6316	F	863,60 (34)	416820-2	-
75	100	1780	404TS	EM2555TS-12	118	852	399,97 (295)	95.3	95.7	95.4	70	79	83	6316	6312	F	862,84 (33.97)	CD0104	25
75	100	1185	444T*	EM2583T-4	116	700	600,63 (443)	94.9	95.3	95	72	81	85	6318	6318	G	1004,82 (39.56)	416820-8	25
93	125	3540	404TS	EM2554T-4	143	1017	249,47 (184)	92.9	93.5	94.1	87	91	91	6312	6312	G	808,99 (31.85)	CD0382	25
93	125	3565	404TS*	EM2554T-4CI	143	834	249,47 (184)	94.8	95.2	95	78	84	86	6313	6313	G	787,40 (31)	416820-36	-
93	125	1775	405T	EM2559T-4	143	914	500,30 (369)	95.5	95.7	95.4	77	84	86	6316	6312	G	875,54 (34.47)	CD0382	25
93	125	1785	405T*	EM2559T-4CI	141	897	498,94 (368)	95.9	96	95.4	77	85	87	6316	6316	G	863,60 (34)	416820-36	-
93	125	1775	405TS	EM2559TS-4	143	914	500,30 (369)	95.5	95.7	95.4	77	84	86	6316	6312	G	888,24 (34.97)	CD0382	25
93	125	1185	445T*	EM2557T-4	146	944	748,41 (552)	95.7	96	95	72	81	83	6318	6318	G	1004,82 (39.56)	416820-8	25
112	150	3560	405TS	EM2556T-4	164	1265	299,64 (221)	95.8	96.1	95.8	81	87	89	6312	6312	G	878,84 (34.6)	CD0382	25
112	150	1785	444T*	EM2558T-4	170	1085	597,92 (441)	96.1	96.4	96.2	74	82	86	6318	6318	G	1004,82 (39.56)	416820-36	-
112	150	1785	444TS*	EM2558TS-4	170	1085	597,92 (441)	96.1	96.4	96.2	74	82	86	6318	6318	G	863,60 (34)	416820-36	-
112	150	1185	445T*	EM2560T-4	175	1070	900,26 (664)	95.4	95.6	95.4	71	80	84	6318	6318	G	1004,82 (39.56)	416820-8	25
149	200	3565	444TS*	EM2562T-4	221	1282	399,97 (295)	95.8	95.9	95.4	87	90	89	6313	6313	G	909,57 (35.81)	416820-8	25
149	200	1785	445T*	EM2563T-4	222	1316	797,22 (588)	96.2	96.3	95.8	82	87	88	6318	6318	G	1004,82 (39.56)	416820-8	25
149	200	1190	447T*	EM2564T-4	232	1401	1198,54 (884)	95.7	95.9	95.4	72	81	85	6318	6318	G	1093,72 (43.06)	416820-8	25
186	250	1785	447T*	EM25254T-4	275	1802	997,88 (736)	96.5	96.6	96.2	84	88	88	6318	6318	G	1093,72 (43.06)	416820-8	25
224	300	1780	449T*	EM25694T-4	330	2131	1198,54 (884)	96.7	96.7	96.2	85	88	89	6318	6318	G	1220,72 (48.06)	416820-8	25
575 volts																			
0,75	1	1760	143T	EM3116T-5	1.2	9.7	4,07 (3)	81.9	84.8	85.5	49	62	71	6205	6203	H	282,45 (11.12)	CD0006	-
1,1	1 1/2	1755	145T	EM3154T-5	1.8	14	6,10 (4.5)	83.3	85.9	86.5	50	64	72	6205	6203	H	295,15 (11.62)	CD0006	-
1,5	2	1750	145T	EM3157T-5	2.3	17.6	8,13 (6)	84.3	86.4	86.5	54	68	76	6205	6203	H	307,85 (12.12)	CD0006	-
2,2	3	1765	182T	EM3211T-5	3.4	26.2	12,07 (8.9)	87.5	89.5	89.5	53	66	73	6206	6205	H	381,00 (15)	CD0006	-
3,7	5	1750	184T	EM3218T-5	5.3	35.7	20,34 (15)	89.3	89.7	89.5	64	75	80	6206	6205	H	419,10 (16.5)	CD0006	-
5,6	7 1/2	1770	213T	EM3311T-5	7.8	54.6	29,96 (22.1)	90.4	91.2	91	62	73	79	6307	6206	H	414,53 (16.32)	CD0006	-
7,5	10	1770	215T	EM3313T-5	10	71.7	40,27 (29.7)	91.7	92.3	91.7	66	77	82	6307	6206	H	443,23 (17.45)	CD0006	-
11	15	1765	254T	EM2513T-5	14.1	94	60,47 (44.6)	93.3	93.5	93	65	77	86	6309	6208	H	550,93 (21.69)	CD0006	-
15	20	1765	256T	EM2515T-5	18.9	130	80,54 (59.4)	92.5	93.2	93	65	82	85	6309	6208	H	550,93 (21.69)	CD0006	-
19	25	1770	284T	EM2531T-5	24.2	155	100,33 (74)	93.4	94.2	93.6	62	73	82	6311	6309	H	604,77 (23.81)	CD0006	-
22	30	1770	286T	EM2535T-5	28	179	120,53 (88.9)	93.6	94.2	94.1	72	82	85	6311	6309	H	636,52 (25.06)	CD0006	-
30	40	1770	324T	EM2539T-5	40	272	161,34 (119)	93.2	94	94.1	63	75	81	6312	6309	H	690,63 (27.19)	CD0006	-
37	50	1775	326T	EM2543T-5	46	305	200,66 (148)	93.5	94.4	94.5	69	79	86	6312	6311	H	703,33 (27.69)	CD0006	-
45	60	1775	364T	EM2547T-5	56	376	239,98 (177)	94.9	95.3	95	77	85	87	6313	6311	H	779,53 (30.69)	CD0006	-
56	75	1775	365T	EM2551T-5	68	401	300,99 (222)	95.4	95.9	95	78	84	87	6313	6312	H	856,49 (33.72)	CD0006	-
75	100	1780	404T	EM2555T-5	93	646	399,97 (295)	95.4	95.6	95.4	73	81	85	6316	6312	H	939,04 (36.97)	CD0006	-
93	125	1775	405T	EM2559T-5	114	752	500,30 (369)	95.6	95.7	95.4	76	84	86	6313	6312	H	875,54 (34.47)	CD0006	-
112	150	1785	444T*	EM2558T-5	136	868	597,92 (441)	96.4	96.6	96.2	83	88	89	6318	6318	H	1004,82 (39.56)	416820-36	-

Notes: Volt code: E = 208-230/460V, 60 Hz; E1 = 230/460V, 60 Hz, usable at 208V; F = 230/460V, 60 Hz; G=460V, 60 Hz; H=575V, 60 Hz

25 = Wye start delta run

* Ratings are cast iron frames.

See pages 45 and 46 for layout drawings. See pages 58 through 61 for connection diagrams.

Efficiencies shown are

NEMA Super-E[®] premium efficient motors

Open drip proof

Small motor rule, single phase, foot mounted

Baldor Reliance[®] Super-E[®] Small Motor Rule motors are compliant with DOE Small Motor Rule 2010. These Super-E steel-band motors comply with DOE Average Efficiency and have a 3 year warranty. The ODP enclosure allows air to pass freely through the motor for excellent heat transfer out of the windings. Class F insulation, a 1.15 service factor and Mobil Polyrex[®] EM grease are some of these motors standard features. Super-E motors have an insulation system that meets the requirements of NEMA MG1 part 31.4.4.2 for VFD use and are considered inverter ready.



ODP – open drip proof – foot mounted, 115/230 volts, single phase, 0.18 - 1.5 kW (1/4 - 2 hp)

kW	Hp	RPM	NEMA frame	Catalog number	Amps @ high V		FL torque Nm (lb-ft)	Efficiency %			Power factor			Bearings		Volt code	"C" dim. mm (in)	Conn. diag. no.	Notes
					Full load	Locked rotor		1/2	3/4	Full load	1/2	3/4	Full load	DE	ODE				
0.18	1/4	1800	48	EL11203	1.3	20.3	1.02 (0.75)	55.5	65.1	68.5	79	85	90	6203	6203	B	247.90 (9.76)	CD0055	13
0.18	1/4	1200	48	EL11204	1.45	16.5	1.55 (1.14)	51.9	61.3	64	73	80	85	6203	6203	B	247.90 (9.76)	CD0055	-
0.25	1/3	3600	48	EL11205	1.5	21.7	0.67 (0.495)	61.5	70.3	70.5	98	98	99	6203	6203	B	247.90 (9.76)	CD0055	13
0.25	1/3	1800	48	EL11206	1.7	24.1	1.35 (0.996)	64.5	69.3	72.4	72	81	85	6203	6203	B	247.90 (9.76)	CD0055	-
0.25	1/3	1800	56	EL11301	1.7	24.1	1.35 (0.996)	64.5	69.3	72.4	72	81	85	6203	6203	B	257.30 (10.13)	CD0055	13
0.25	1/3	1200	56	EL11302	2.3	20.8	2.05 (1.51)	59.2	66.9	68	72	79	83	6203	6203	B	257.30 (10.13)	CD0055	-
0.37	1/2	3600	48	EL11208	2.5	39.3	1.02 (0.756)	59.2	69	72.4	81	87	91	6203	6203	B	247.90 (9.76)	CD0055	-
0.37	1/2	3600	56	EL11303	2.5	39.3	1.02 (0.756)	59.2	69	72.4	81	87	91	6203	6203	B	257.30 (10.13)	CD0055	12
0.37	1/2	1800	56	EL11304	2.4	31.9	2.05 (1.51)	73	76.8	76.2	94	95	95	6203	6203	B	279.40 (11.00)	CD0055	12
0.37	1/2	1200	56H	EL11305	2.2	32	3.08 (2.27)	69.5	76.6	76.2	91	94	94	6205	6203	B	298.45 (11.75)	CD0055	36
0.55	3/4	3600	56	EL11306	3.3	24.8	1.55 (1.14)	62.6	74.2	76.2	89	93	95	6203	6203	B	279.40 (11.00)	CD0055	12
0.55	3/4	1800	56	EL11307	3.5	64.4	3.04 (2.24)	75.9	81.3	81.8	71	80	85	6205	6203	B	306.58 (12.07)	CD0055	12
0.75	1	3600	56	EL11309	3.9	60	2.05 (1.51)	79.9	83.3	82	98	99	100	6205	6203	B	306.58 (12.07)	CD0055	12
0.75	1	1800	56	EL11310	4.2	73.1	4.03 (2.97)	74.5	81.2	82.6	87	91	93	6205	6203	B	306.58 (12.07)	CD0055	-
1.1	1 1/2	3600	56H	EL11313	5.9	73.7	3.06 (2.26)	80.9	83.3	82	89	98	100	6205	6203	B	320.55 (12.62)	CD0055	36
1.1	1 1/2	1800	56H	EL11319	6.2	101	6.07 (4.48)	81.2	84.2	83.8	86	91	93	6205	6203	B	355.60 (14.00)	CD0055	36
1.5	2	3600	56H	EL11317	7.8	98.8	4.09 (3.02)	82	84.1	82.9	100	100	99	6205	6203	B	355.60 (14.00)	CD0055	36

Notes: Volt code: B = 115/230V, 60 Hz

12 = 1.25 service factor

13 = 1.35 service factor

36 = Can mount as NEMA 56, 143T & 145T frames with NEMA 56 frame shaft dimensions.

These motors meet DOE Small Motor Rule 2010, and are not considered premium efficient.

See page 56 for layout drawing. See page 59 for connection diagram.

Efficiencies shown are nominal. Data subject to change without notice. Contact your ABB regional support office for certified data.

NEMA Super-E[®] premium efficient motors

Open drip proof

Small motor rule, three phase, foot mounted

Baldor Reliance[®] Super-E[®] Small Motor Rule motors are compliant with DOE Small Motor Rule 2010. These Super-E steel-band motors comply with DOE Average Efficiency and have a 3 year warranty. The ODP enclosure allows air to pass freely through the motor for excellent heat transfer out of the windings. Class F insulation, a 1.15 service factor and Mobil Polyrex[®] EM grease are some of these motors standard features. Super-E motors have an insulation system that meets the requirements of NEMA MG1 part 31.4.4.2 for VFD use and are considered inverter ready.



ODP – open drip proof – foot mounted, 230/460 volts, three phase, 0.18 - 2.2 kW (1/4 - 3 hp)

Hp	RPM	NEMA frame	Catalog number	Amps @ high V		FL torque Nm (lb-ft)	Efficiency %			Power factor			Bearings		Volt code	"C" dim. mm (in)	Conn. diag. no.	Notes
				Full load	Locked rotor		1/2	3/4	Full load	1/2	3/4	Full load	DE	ODE				
1/4	1800	48	EM30003	0.5	3.43	1.03 (0.76)	65.9	72.5	69.5	41	53	62	6203	6203	E1	244.35 (9.62)	CD0005	-
1/4	1200	56	EM31101	0.7	3.58	1.55 (1.14)	57.9	65.1	67.5	31	39	47	6203	6203	E1	260.35 (10.25)	CD0005	-
1/3	3600	48	EM30006	0.6	4.66	0.68 (0.502)	59.5	67.4	69.5	59	69	77	6203	6203	E1	244.35 (9.62)	CD0005	-
1/3	1800	56	EM31104	0.7	4.74	1.37 (1.01)	69.8	74.8	73.4	45	57	66	6203	6203	E1	260.35 (10.25)	CD0005	-
1/3	1200	56	EM31105	0.9	4.63	2.10 (1.55)	64.3	69.7	71.4	33	43	51	6203	6203	E1	276.35 (10.88)	CD0005	-
1/2	3600	48	EM30009	0.8	4.44	1.04 (0.767)	67.8	73.9	73.4	61	72	78	6203	6203	E1	244.35 (9.62)	CD0005	-
1/2	3600	56	EM31107	0.8	7.88	1.04 (0.767)	67.8	73.9	73.4	61	72	78	6203	6203	E1	260.35 (10.25)	CD0005	-
1/2	1800	48	EM30010	0.8	6.16	2.13 (1.57)	76.6	78.9	78.2	55	68	76	6203	6203	E1	282.45 (11.12)	CD0005	-
1/2	1800	56	EM31108	0.8	6.16	2.13 (1.57)	76.6	78.9	78.2	55	68	76	6203	6203	E1	298.45 (11.75)	CD0005	-
1/2	1200	56	EM31109	1	4.7	3.20 (2.36)	73.6	76.7	75.3	43	54	63	6203	6203	E1	298.45 (11.75)	CD0005	-
3/4	3600	56	EM31111	1.2	9.2	1.56 (1.15)	73.6	77.6	76.8	64	75	82	6203	6203	E1	260.35 (10.25)	CD0005	-
3/4	1800	56	EM31112	1	7.06	3.06 (2.26)	80.6	82.3	81.5	66	77	84	6205	6203	E1	281.18 (11.07)	CD0005	-
3/4	1200	56	EM31153	1.3	8.42	4.58 (3.38)	78.1	80.8	81.7	44	56	65	6205	6203	E1	306.58 (12.07)	CD0005	-
1	3600	56	EM31115	1.6	26.5	2.03 (1.5)	64.5	70.6	77	66	71	83	6203	6203	E1	276.35 (10.88)	CD0005	-
1	1800	56	EM31116	1.5	12.8	4.05 (2.99)	80.7	83.4	83.5	55	68	78	6205	6203	E1	281.18 (11.07)	CD0005	-
1	1200	56H	EM31156	1.8	10.8	6.10 (4.5)	79.4	82.3	82.5	43	55	64	6205	6203	E1	298.45 (11.75)	CD0005	36
1 1/2	3600	56	EM31120	2	17.2	3.06 (2.26)	82.2	84.7	84	64	76	83	6205	6203	E1	281.18 (11.07)	CD0005	-
1 1/2	1800	56	EM31154	2.2	13.4	6.06 (4.47)	84.5	86.8	86.5	51	65	73	6205	6203	E1	306.58 (12.07)	CD0005	-
1 1/2	1200	56H	EM31159	2.6	17.8	9.23 (6.81)	80.8	83.7	84	44	56	65	6205	6203	E1	355.60 (14.00)	CD0005	36
2	3600	56	EM31155	2.6	18.8	4.07 (3)	84.9	86.2	85.5	73	82	86	6205	6203	E1	306.58 (12.07)	CD0005	-
2	1800	56H	EM31157	2.9	23.9	8.11 (5.98)	84.1	86.3	86.5	53	66	75	6205	6203	E1	298.45 (11.75)	CD0005	36
3	3600	56H	EM31158	3.7	35.5	6.38 (4.704)	86.4	87	85.5	78	86	90	6205	6203	E1	320.55 (12.62)	CD0005	36

Notes: Volt code: E1 = 230/460V, 60 Hz, usable at 208V

36 = Can mount as NEMA 56, 143T & 145T frames with NEMA 56 frame shaft dimensions.

These motors meet DOE Small Motor Rule 2010, and are not considered premium efficient.

See page 45 for layout drawing. See page 58 for connection diagram.

Efficiencies shown are nominal. Data subject to change without notice. Contact your ABB regional support office for certified data.

NEMA Super-E[®] premium efficient motors

Open drip proof
F2 mounting



NEMA
Premium

ODP – open drip proof, foot mounted, 230/460, 460 & 575 volts, three phase, 0.75 - 45 kW (1 - 60 hp)

kW	Hp	RPM	Frame	Catalog number	Amps @ high V		F.L. torque Nm (lb-ft)	Efficiency %			Power factor %			Bearings		Volt code	"C" dim. mm (in)	Conn. diag. no.
					Full load	Locked rotor		1/2	3/4	Full load	1/2	3/4	Full load	DE	ODE			
575 volts (continued)																		
0.75	1	1760	145T	EFM3116T	1.5	12.1	4,07 (3)	82.1	84.8	85.5	49	62	71	6205	6203	E	282,45 (11.12)	CD0005
1.1	1 1/2	1755	145T	EFM3154T	2.2	12.6	6,10 (4.5)	83.5	86	86.5	50	63	72	6205	6203	E1	295,15 (11.62)	CD0005
1.5	2	1750	145T	EFM3157T	2.9	19	8,13 (6)	84.4	86.6	86.5	51	64	73	6205	6203	E1	307,85 (12.12)	CD0005
2.2	3	1765	182T	EFM3211T	4.2	32.3	12,07 (8.9)	87.5	89.5	89.5	53	66	73	6206	6205	E1	381,00 (15)	CD0005
3.7	5	1750	184T	EFM3218T	6.6	44.8	20,34 (15)	89.7	90.2	89.5	64	75	80	6206	6205	E	419,10 (16.5)	CD0005
5.6	7 1/2	1770	213T	EFM3311T	9.7	68.2	29,96 (22.1)	90.5	91.4	91	62	73	79	6307	6206	E1	414,53 (16.32)	CD0005
7.5	10	1770	215T	EFM3313T	12.5	88.3	40,27 (29.7)	91.6	92.3	91.7	66	77	82	6307	6206	E1	443,23 (17.45)	CD0005
11	15	1765	254T	EFM2513T	17.7	118	60,47 (44.6)	93.3	93.5	93	70	81	86	6309	6208	E1	550,93 (21.69)	CD0180
15	20	1765	256T	EFM2515T	23.5	160.8	80,54 (59.4)	92.5	93.2	93	71	81	86	6309	6208	E1	550,93 (21.69)	CD0180
19	25	1760	284T	EFM2531T	29	180	100,33 (74)	93.2	93.9	93.6	72	82	86	6311	6309	E1	604,77 (23.81)	CD0180
22	30	1770	286T	EFM2535T	35	223.6	120,53 (88.9)	93.6	94.2	94.1	72	82	85	6311	6309	E1	636,52 (25.06)	CD0005
30	40	1770	324T	EFM2539T	49	330	161,34 (119)	94	94.5	94.1	65	76	82	6312	6309	E1	690,63 (27.19)	CD0005
37	50	1775	326T	EFM2543T	57	378	200,66 (148)	94.5	94.9	94.5	75	84	87	6312	6311	E1	703,33 (27.69)	CD0180
45	60	1775	364T	EFM2547T	68	470	239,98 (177)	94.9	95.3	95	77	85	87	6313	6311	E1	779,53 (30.69)	CD0180

Notes: Volt code: E = 208-230/460V, 60 Hz; E1 = 230/460V, 60 Hz, usable at 208V

Contact your ABB regional support office for layout drawings. See pages 58 and 60 for connection diagrams.

Efficiencies shown are nominal. Data subject to change without notice. Contact your ABB regional support office for certified data.

Open drip proof
C-face foot mounted

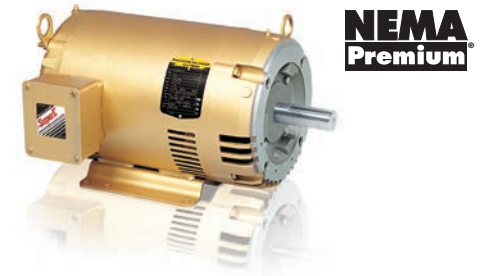

NEMA
Premium

ODP – open drip proof – 230/460 volts, three phase, 0.75 - 75 kW (1 - 100 hp)

kW	Hp	RPM	Frame	Catalog number	Amps @ high V		F.L. torque Nm (lb-ft)	Efficiency %			Power factor %			Bearings		Volt code	"C" dim. mm (in)	Conn. diag. no.
					Full load	Locked rotor		1/2	3/4	Full load	1/2	3/4	Full load	DE	ODE			
0.75	1	1760	143TC	CEM3116T	1.5	12.1	4,03 (2.97)	82.1	84.8	85.5	49	62	71	6205	6203	E	295,15 (11.62)	CD0005
1.1	1 1/2	1755	145TC	CEM3154T	2.2	17.5	6,05 (4.46)	83.5	86	86.5	50	63	72	6205	6203	E1	295,15 (11.62)	CD0005
1.5	2	1750	145TC	CEM3157T	2.9	24.3	8,08 (5.96)	84.4	86.6	86.5	51	64	73	6205	6203	E1	307,85 (12.12)	CD0005
2.2	3	3450	145TC	CEM3158T	3.8	32.5	6,10 (4.5)	84.3	86	85.5	72	82	87	6205	6203	E	330,20 (13)	CD0005
2.2	3	1765	182TC	CEM3211T	4.2	32.3	12,03 (8.87)	87.5	89.5	89.5	53	66	73	6206	6205	E1	381,00 (15)	CD0005
3.7	5	3450	182TC	CEM3212T	6	50.7	10,39 (7.66)	86.7	87.6	86.5	81	88	91	6206	6205	E	345,95 (13.62)	CD0005
3.7	5	1750	184TC	CEM3218T	6.6	44.8	20,34 (15)	89.7	90.2	89.5	64	75	80	6206	6205	E	419,10 (16.5)	CD0005
5.6	7 1/2	3450	184TC	CEM3219T	8.6	86.3	15,32 (11.3)	88.1	89.2	88.5	80	87	91	6206	6205	E	381,00 (15)	CD0005
5.6	7 1/2	1770	213TC	CEM3311T	9.7	68.2	29,96 (22.1)	90.5	91.4	91	62	73	79	6307	6206	E	433,32 (17.06)	CD0005
7.5	10	3500	213TC	CEM3312T	11.4	98	20,34 (15)	90.9	92	91.7	84	87	90	6307	6206	E	462,03 (18.19)	CD0005
7.5	10	1770	215TC	CEM3313T	12.5	88.3	40,27 (29.7)	91.6	92.3	91.7	66	77	82	6307	6206	E	462,03 (18.19)	CD0005
11	15	3525	215TC	CEM3314T	17.5	143	30,51 (22.5)	91.9	92.3	90.2	80	87	89	6307	6206	E1	433,32 (17.06)	CD0005
11	15	1765	254TC	CEM2513T	17.7	118	60,47 (44.6)	93.3	93.5	93	70	81	86	6309	6208	E	550,93 (21.69)	CD0005
15	20	3510	254TC	CEM2514T	23.5	153	40,13 (29.6)	90.1	91.2	91	74	83	87	6309	6208	E1	550,93 (21.69)	CD0180
15	20	1765	256TC	CEM2515T	23.5	160.8	80,54 (59.4)	92.5	93.2	93	71	81	86	6309	6208	E1	550,93 (21.69)	CD0180
19	25	3515	256TC	CEM2516T	28	197	50,44 (37.2)	91.8	92.3	91.7	79	86	89	6309	6208	E1	550,93 (21.69)	CD0180
19	25	1760	284TC	CEM2531T	29	180	100,33 (74)	93.2	93.9	93.6	72	82	86	6311	6309	E1	604,77 (23.81)	CD0180
22	30	1770	286TC	CEM2535T	35	223.6	120,53 (88.9)	93.6	94.2	94.1	72	82	85	6311	6309	E1	636,52 (25.06)	CD0005
30	40	1775	324TC	CEM2539T	47	280	159,99 (118)	93.6	94.4	94.1	76	82	84	6312	6311	E1	677,93 (26.69)	CD0180
37	50	1775	326TC	CEM2543T	57	378	200,66 (148)	94.5	94.9	94.5	75	84	87	6312	6311	E1	703,33 (27.69)	CD0180
45	60	1775	364TC	CEM2547T	68	470	239,98 (177)	94.9	95.3	95	77	85	87	6313	6311	E1	779,53 (30.69)	CD0180
56	75	1775	365TC	CEM2551T	87	512	300,99 (222)	95.5	95.7	95	78	84	87	6313	6312	F	856,49 (33.72)	CD0180
75	100	1780	404TC	CEM2555T	118	852	399,97 (295)	95.3	95.7	95.4	70	79	83	6313	6312	F	939,04 (36.97)	CD0180

Notes: Volt code: E = 208-230/460V, 60 Hz; E1 = 230/460V, 60 Hz, usable at 208V; F = 230/460V, 60 Hz

Contact your ABB regional support office for layout drawings. See pages 58 and 60 for connection diagrams.

Efficiencies shown are nominal. Data subject to change without notice. Contact your ABB regional support office for certified data.

NEMA Super-E[®] premium efficient motors

Close coupled pump motors with AEGIS[®] grounding ring

TEFC



These motors are designed and manufactured for commercial and industrial pump applications where adjustable speed drives are utilized. They feature Class H insulation with an AEGIS[®] bearing protection ring installed internally. Motors include oversized ball bearings with locked drive end construction to minimize endplay. All models meet or exceed NEMA Premium[®] efficiencies, are inverter ready, and have a 3-year warranty.

TEFC – totally enclosed fan cooled – foot mounted, 230/460 volts, three phase, 2.2 - 15 kW (3 - 20 hp)

kW	Hp	RPM	Frame	Catalog number	Amps @ high V		F.L. torque Nm (lb-ft)	Efficiency %		Power factor %			Bearings		Volt code	"C" dim. mm (in)	Conn. diag. no.	
					Full load	Locked rotor		1/2	3/4	Full load	1/2	3/4	Full load	DE				ODE
2.2	3	3450	182JM	EJMM3610T-G	3.6	33	6,10 (4.5)	87.9	88.2	86.5	81	88	92	6207	6203	E	429,51 (16.91)	CD0005
2.2	3	1760	182JM	EJMM3611T-G	4.2	32	12,07 (8.9)	87.8	89.5	89.5	54	68	75	6207	6205	E	458,72 (18.06)	CD0005
3.7	5	3450	184JM	EJMM3613T-G	5.9	57.2	10,30 (7.6)	88.4	89.1	88.5	81	88	91	6207	6205	E	458,72 (18.06)	CD0005
3.7	5	1750	184JM	EJMM3615T-G	6.7	49.1	20,20 (14.9)	89.7	90.3	89.5	60	72	78	6207	6205	E	496,82 (19.56)	CD0005
5.6	7 1/2	3470	213JM	EJMM3709T-G	8.6	63.1	15,05 (11.1)	89.2	90.1	89.5	80	87	90	6309	6206	F	503,17 (19.81)	CD0005
5.6	7 1/2	1770	213JM	EJMM3710T-G	9.4	70.1	30,37 (22.4)	92.2	92.7	91.7	63	75	81	6309	6206	E1	531,88 (20.94)	CD0005
7.5	10	3490	215JM	EJMM3711T-G	11.8	78.5	20,34 (15)	91	91.3	90.2	74	84	87	6309	6206	E	503,17 (19.81)	CD0005
7.5	10	1770	215JM	EJMM3714T-G	12	103	40,00 (29.5)	92.1	92.4	91.7	66	79	85	6309	6206	E	569,98 (22.44)	CD0005
11	15	3520	254JM*	EJMM2394T-G	17.5	110	29,96 (22.1)	91	91.6	91	77	85	87	6309	6208	E1	642,62 (25.3)	CD0180
11	15	1765	254JM*	EJMM2333T-G	18.5	122.9	60,47 (44.6)	91.9	92.6	92.4	66	77	82	6309	6208	E1	642,62 (25.3)	CD0005
15	20	3520	256JM*	EJMM4106T-G	23	161	40,13 (29.6)	92.2	92.4	91	78	86	89	6309	6208	E1	642,62 (25.3)	CD0005
15	20	1765	256JM*	EJMM2334T-G	24	175	79,99 (59)	92.8	93.1	93	69	80	84	6309	6208	E1	642,62 (25.3)	CD0005

Notes: Volt code: E = 208-230/460 volts; E1 = 230/460 volts, usable at 208 volts; F = 230/460 volts
* Ratings are cast iron frames.

See page 50 for layout drawing. See pages 58 and 60 for connection diagrams.

Efficiencies shown are nominal. Data subject to change without notice. Contact your ABB regional support office for certified data.

Close coupled pump motors with AEGIS[®] grounding ring

ODP

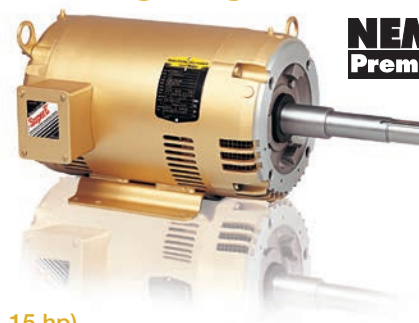

These motors are designed and manufactured for commercial and industrial pump applications where adjustable speed drives are utilized. They feature Class H insulation with an AEGIS[®] bearing protection ring installed internally. Motors include oversized ball bearings with locked drive end construction to minimize endplay. All models meet or exceed NEMA Premium[®] efficiencies, are inverter ready, and have a 3-year warranty.

ODP – open drip proof – foot mounted, 230/460 volts, three phase, 0.75 - 11 kW (1 - 15 hp)

kW	Hp	RPM	Frame	Catalog number	Amps @ high V		F.L. torque Nm (lb-ft)	Efficiency %		Power factor %			Bearings		Volt code	"C" dim. mm (in)	Conn. diag. no.	
					Full load	Locked rotor		1/2	3/4	Full load	1/2	3/4	Full load	DE				ODE
0,75	1	1760	143JM	EJMM3116T-G	1.5	12.1	4,07 (3)	82.1	84.8	85.5	49	62	71	6206	6203	E	349,25 (13.75)	CD0005
1,1	1 1/2	1755	145JM	EJMM3154T-G	2.2	17.5	6,10 (4.5)	83.5	86	86.5	50	63	72	6206	6203	E1	349,25 (13.75)	CD0005
1,5	2	1750	145JM	EJMM3157T-G	2.9	24.3	8,13 (6)	84.4	86.6	86.5	51	64	73	6206	6203	E1	361,95 (14.25)	CD0005
2,2	3	3450	145JM	EJMM3158T-G	3.8	32.5	6,10 (4.5)	83.8	85.4	85.5	72	82	87	6206	6203	E1	384,30 (15.13)	CD0005
2,2	3	1765	182JM	EJMM3211T-G	4.2	32.3	12,07 (8.9)	87.5	89.5	89.5	53	66	73	6207	6205	E1	419,10 (16.5)	CD0005
3,7	5	3450	182JM	EJMM3212T-G	6	50.7	10,44 (7.7)	86.7	87.6	86.5	81	88	91	6207	6205	E	384,05 (15.12)	CD0005
3,7	5	1750	184JM	EJMM3218T-G	6.6	44.8	20,34 (15)	89.7	90.2	89.5	64	75	80	6207	6205	E	457,20 (18)	CD0005
5,6	7 1/2	3450	184JM	EJMM3219T-G	8.6	86.3	15,32 (11.3)	88.1	89.2	88.5	80	87	91	6207	6205	E	419,10 (16.5)	CD0005
5,6	7 1/2	1770	213JM	EJMM3311T-G	9.7	68.2	29,96 (22.1)	90.5	91.4	91	92	73	79	6309	6206	F	462,03 (18.19)	CD0005
7,5	10	3500	213JM	EJMM3312T-G	11.4	98	20,34 (15)	90.9	92	91.7	81	87	90	6309	6206	E	490,47 (19.31)	CD0005
7,5	10	1770	215JM	EJMM3313T-G	12.5	88.3	40,27 (29.7)	91.6	92.3	91.7	66	77	82	6309	6206	F	490,47 (19.31)	CD0005
11	15	3525	215JM	EJMM3314T-G	17.5	143	30,51 (22.5)	91.9	92.3	90.2	80	87	89	6309	6206	F	462,03 (18.19)	CD0005
11	15	1765	254JM	EJMM2513T-G	17.7	118	60,47 (44.6)	93.3	93.5	93	70	81	86	6309	6208	E1	589,03 (23.19)	CD0180

Notes: Volt code: E = 208-230/460 volts; E1 = 230/460 volts, usable at 208 volts; F = 230/460 volts.

See page 52 for layout drawings. See pages 58 and 60 for connection diagrams.

Efficiencies shown are nominal. Data subject to change without notice. Contact your ABB regional support office for certified data.

NEMA Super-E[®] premium efficient motors

Close coupled pump motors – TEFC

Close coupled pump, TEFC, premium efficient motors are designed to meet a wide variety of applications for circulating and transferring fluids. These motors have a JP shaft configuration and have mounting that is designed to support the pump unit. These motors feature over-sized ball bearings with locked drive end construction to minimize endplay.



TEFC – totally enclosed fan cooled – 230/460 volts, three phase, 0.75 - 37 kW (1 - 50 hp)

kW	Hp	RPM	Frame	Catalog number	Amps @ high V		F.L. torque Nm (lb-ft)	Efficiency %			Power factor %			Bearings		Volt code	"C" dim. mm (in)	Conn. diag. no.
					Full load	Locked rotor		1/2	3/4	Full load	1/2	3/4	Full load	DE	ODE			
C-face foot mounted																		
0.75	1	1760	143JM	EJMM3546T	1.5	12.1	4,07 (3)	82.1	84.8	85.5	49	62	71	6206	6203	E	391.92 (15.43)	CD0005
1.1	1 1/2	3500	143JM	EJMM3550T	1.9	17.9	2,98 (2.2)	82.2	84.4	84	67	79	85	6206	6203	E	391.92 (15.43)	CD0005
1.1	1 1/2	1760	145JM	EJMM3554T	2.2	18.3	6,10 (4.5)	84.5	86.8	86.5	51	65	73	6206	6203	E	391.92 (15.43)	CD0005
1.5	2	3490	145JM	EJMM3555T	2.5	25.9	4,07 (3)	83.5	85.9	85.5	75	84	88	6206	6203	E	391.92 (15.43)	CD0005
1.5	2	1755	145JM	EJMM3558T	2.9	24.3	8,13 (6)	84.2	86.4	86.5	51	64	73	6206	6203	E	414.27 (16.31)	CD0005
2.2	3	3450	143JM	EJMM3559T	3.6	33	6,10 (4.5)	87.9	88.2	86.5	81	88	92	6206	6203	E	414.27 (16.31)	CD0005
2.2	3	3450	182JM	EJMM3610T	3.6	33	6,10 (4.5)	87.9	88.2	86.5	81	88	92	6207	6203	E	427.74 (16.84)	CD0005
2.2	3	1760	182JM	EJMM3611T	4.2	32	12,07 (8.9)	87.8	89.5	89.5	54	68	75	6207	6205	E	458.72 (18.06)	CD0005
3.7	5	3450	184JM	EJMM3613T	5.9	57.2	10,30 (7.6)	88.4	89.1	88.5	81	88	91	6207	6205	E	458.72 (18.06)	CD0005
3.7	5	1750	184JM	EJMM3615T	6.7	49.1	20,20 (14.9)	89.7	90.3	89.5	60	72	78	6207	6205	E	496.82 (19.56)	CD0005
5.6	7 1/2	3450	184JM	EJMM3616T	8.4	91	15,46 (11.4)	90.6	90.7	89.5	85	90	93	6207	6205	E	496.82 (19.56)	CD0005
5.6	7 1/2	3470	213JM	EJMM3709T	8.6	63.1	15,05 (11.1)	89.2	90.1	89.5	80	87	90	6309	6206	F	503.17 (19.81)	CD0005
5.6	7 1/2	1770	213JM	EJMM3710T	9.4	70.1	30,37 (22.4)	92.2	92.7	91.7	63	75	81	6309	6206	E1	531.88 (20.94)	CD0005
7.5	10	3490	215JM	EJMM3711T	11.8	78.5	20,34 (15)	91	91.3	90.2	74	84	87	6309	6206	E	503.17 (19.81)	CD0005
7.5	10	1770	215JM	EJMM3714T	12	103	40,00 (29.5)	92.1	92.4	91.7	66	79	85	6309	6206	E	569.98 (22.44)	CD0005
7.5	10	1770	215JP	EJPM3714T	12	103	40,00 (29.5)	92.1	92.4	91.7	66	79	85	6309	6206	E	667.77 (26.29)	CD0005
11	15	3520	254JM*	EJMM2394T	17.5	110	29,96 (22.1)	91	91.6	91	77	85	87	6309	6208	E1	642.62 (25.3)	CD0180
11	15	3525	254JP*	EJPM2394T	17.8	131	30,10 (22.2)	90.4	91.3	91	73	82	86	6309	6208	E	715.26 (28.16)	CD0180
11	15	1765	254JM*	EJMM2333T	18.5	122.9	60,47 (44.6)	91.9	92.6	92.4	66	77	82	6309	6208	E1	642.62 (25.3)	CD0005
11	15	1765	254JP*	EJPM2333T	18.5	122.9	60,47 (44.6)	91.9	92.6	92.4	66	77	82	6309	6208	E	712.22 (28.04)	CD0005
15	20	3520	256JM*	EJMM4106T	23	161	40,13 (29.6)	92.2	92.4	91	78	86	89	6309	6208	E1	642.62 (25.3)	CD0005
15	20	3510	256JP*	EJPM4106T	23	159	40,40 (29.8)	92.2	92.1	91	78	85	89	6309	6208	E	715.26 (28.16)	CD0180
15	20	1765	256JM*	EJMM2334T	24	175	79,99 (59)	92.8	93.1	93	69	80	84	6309	6208	E1	642.62 (25.3)	CD0005
15	20	1765	256JP*	EJPM2334T	24	121	79,99 (59)	92.8	93.1	93	69	80	84	6309	6208	E1	715.26 (28.16)	CD0005
19	25	3525	284JM*	EJMM4107T	29	249	50,17 (37)	89.2	91.2	91.7	75	83	90	6312	6208	E1	684.78 (26.96)	CD0005
19	25	3525	284JP*	EJPM4107T	29	249	50,17 (37)	89.2	91.2	91.7	75	83	90	6312	9208	E1	757.94 (29.84)	CD0005
19	25	1770	284JM*	EJMM4103T	30	186	100,60 (74.2)	92.3	93.5	93.6	73	81	85	6312	6309	E1	727.46 (28.64)	CD0005
19	25	1770	284JP*	EJPM4103T	30	186	100,60 (74.2)	92.3	93.5	93.6	73	81	85	6312	6309	E1	800.35 (31.51)	CD0005
22	30	3520	286JM*	EJMM4108T	33	214	60,33 (44.5)	92.8	93.2	91.7	83	89	91	6312	6309	E	727.46 (28.64)	CD0180
22	30	3520	286JP*	EJPM4108T	35	211	61,15 (45.1)	92.3	92.9	91.7	77	85	87	6312	6309	E	800.35 (31.51)	CD0180
22	30	1770	286JM*	EJMM4104T	36	235	120,80 (89.1)	93.7	94.3	93.6	66	75	83	6312	6309	E1	727.46 (28.64)	CD0005
22	30	1770	286JP*	EJPM4104T	36	235	120,80 (89.1)	93.7	94.3	93.6	66	75	73	6312	6309	E1	800.35 (31.51)	CD0005
30	40	3530	324JM*	EJMM4109T	45	324	80,67 (59.5)	93.4	93.7	92.4	82	88	90	6312	6309	E	778.26 (30.64)	CD0180
30	40	3530	324JP*	EJPM4109T	45	324	80,67 (59.5)	93.4	93.7	92.4	82	88	90	6312	6309	E	851.15 (33.51)	CD0180
30	40	1775	324JM*	EJMM4110T	48	338	159,99 (118)	93.5	94.2	94.1	69	78	83	6312	6311	E1	778.51 (30.65)	CD0180
30	40	1775	324JP*	EJPM4110T	48	338	159,99 (118)	93.5	94.2	94.1	69	78	83	6312	6311	E1	848.61 (33.41)	CD0180
37	50	3540	326JM*	EJMM4114T	56	431	100,47 (74.1)	93.5	94.3	93	78	85	89	6312	6311	E	778.51 (30.65)	CD0180
37	50	3540	326JP*	EJPM4114T	56	431	100,47 (74.1)	93.5	94.3	93	78	85	89	6312	6311	E1	848.61 (33.41)	CD0180
37	50	1775	326JM*	EJMM4115T	57	392	202,02 (149)	94.4	94.9	94.5	73	82	85	6312	6311	E1	778.51 (30.65)	CD0180
37	50	1775	326JP*	EJPM4115T	57	392	202,02 (149)	94.4	94.9	94.5	73	82	85	6312	6311	E1	848.61 (33.41)	CD0180
C-face footless																		
0.75	1	1760	143JM	VEJMM3546T	1.5	12.1	4,07 (3)	82.1	84.8	85.5	49	62	71	6206	6203	E	366.52 (14.43)	CD0005
1.1	1 1/2	1760	145JM	VEJMM3554T	2.2	18.3	6,10 (4.5)	84.5	86.8	86.5	51	65	73	6206	6203	E	391.92 (15.43)	CD0005
1.5	2	1755	145JM	VEJMM3558T	2.9	24.3	8,13 (6)	84.2	86.4	86.5	51	64	73	6206	6203	E	414.27 (16.31)	CD0005
2.2	3	1760	182JM	VEJMM3611T	4.2	32	12,07 (8.9)	87.8	89.5	89.5	54	68	75	6207	6205	E	458.72 (18.05)	CD0005
3.7	5	1750	184JM	VEJMM3615T	6.7	49.1	20,20 (14.9)	89.7	90.3	89.5	60	72	78	6207	6205	E	500.38 (19.7)	CD0005
5.6	7 1/2	1770	213JM	VEJMM3710T	9.4	70.1	30,37 (22.4)	92.2	92.7	91.7	63	75	81	6309	6206	E1	531.37 (20.92)	CD0005
7.5	10	1770	215JM	VEJMM3714T	12	103	40,00 (29.5)	92.1	92.4	91.7	66	79	85	6309	6206	E	568.96 (22.4)	CD0005

Notes: Volt code: E = 208-230/460 volts; E1 = 230/460 volts, usable at 208 volts; F = 230/460 volts.

* Ratings are cast iron frames.

See pages 50 and 51 for layout drawings. See pages 58 and 60 for connection diagrams.

Efficiencies shown are nominal. Data subject to change without notice. Contact your ABB regional support office for certified data.

NEMA Super-E[®] premium efficient motors

Close coupled pump motors – ODP



These motors are designed and manufactured to meet the needs of circulating and transferring fluid applications. The motor flange and shaft are designed to support the pump unit. Close coupled pump motors include over-sized ball bearings with locked drive end construction to minimize endplay. Open drip proof frame designs include rodent screens on both ends. These Super-E[®] motors meet NEMA Premium[®] efficiency requirements, have a 1.15 service factor and class F insulation.

ODP - open drip proof – 230/460 volts, three phase, 0.75 - 37 kW (1 - 50 hp)

kW	Hp	RPM	Frame	Catalog number	Amps @ high V		F.L. torque Nm (lb-ft)	Efficiency %		Power factor %			Bearings		Volt code	"C" dim. mm (in)	Conn. diag. no.	
					Full load	Locked rotor		1/2	3/4	Full load	1/2	3/4	Full load	DE				ODE
C-face foot mounted																		
0,75	1	1760	143JM	EJMM3116T	1.5	12.1	4,07 (3)	82.1	84.8	85.5	49	62	71	6206	6203	E	349,25 (13.75)	CD0005
1,1	1 1/2	1755	145JM	EJMM3154T	2.2	17.5	6,10 (4.5)	83.5	86	86.5	50	63	72	6206	6203	F	349,25 (13.75)	CD0005
1,5	2	3450	145JM	EJMM3155T	2.5	21.5	4,07 (3)	85.2	86.8	85.5	72	82	87	6206	6203	E	349,25 (13.75)	CD0005
1,5	2	1750	145JM	EJMM3157T	2.9	24.3	8,13 (6)	84.4	86.6	86.5	51	64	73	6206	6203	F	361,95 (14.25)	CD0005
2,2	3	3450	145JM	EJMM3158T	3.8	32.5	6,10 (4.5)	83.8	85.4	85.5	72	82	87	6206	6203	E1	384,30 (15.13)	CD0005
2,2	3	1765	182JM	EJMM3211T	4.2	32.3	12,07 (8.9)	87.5	89.5	89.5	53	66	73	6207	6205	E1	419,10 (16.5)	CD0005
3,7	5	3450	182JM	EJMM3212T	6	50.7	10,44 (7.7)	86.7	87.6	86.5	81	88	91	6207	6205	E	384,05 (15.12)	CD0005
3,7	5	1750	184JM	EJMM3218T	6.6	44.8	20,34 (15)	89.7	90.2	89.5	64	75	80	6207	6205	E	457,20 (18)	CD0005
5,6	7 1/2	3450	184JM	EJMM3219T	8.6	86.3	15,32 (11.3)	88.1	89.2	88.5	80	87	91	6207	6205	E	419,10 (16.5)	CD0005
5,6	7 1/2	1770	213JM	EJMM3311T	9.7	68.2	29,96 (22.1)	90.5	91.4	91	92	73	79	6309	6206	E1	462,03 (18.19)	CD0005
7,5	10	3500	213JM	EJMM3312T	11.4	98	20,34 (15)	90.9	92	90.2	81	87	90	6309	6206	E	490,47 (19.31)	CD0005
7,5	10	3500	213JP	EJPM3312T	11.4	98	20,34 (15)	90.9	92.4	90.2	86	89	90	6309	6206	E	560,58 (22.07)	CD0005
7,5	10	1770	215JM	EJMM3313T	12.5	88.3	40,27 (29.7)	91.6	92.3	91.7	66	77	82	6309	6206	E1	490,47 (19.31)	CD0005
7,5	10	1770	215JP	EJPM3313T	12.5	88.3	40,27 (29.7)	91.7	92.2	91.6	66	77	82	6309	6206	E	560,58 (22.07)	CD0005
11	15	3525	215JM	EJMM3314T	17.5	143	30,51 (22.5)	91.9	92.3	90.2	80	87	89	6309	6206	E	462,03 (18.19)	CD0005
11	15	3525	215JP	EJPM3314T	17.5	143	30,51 (22.5)	91.9	92.3	90.2	80	87	89	6309	6206	E	531,88 (20.94)	CD0005
11	15	1765	254JM	EJMM2513T	17.7	118	60,47 (44.6)	93.3	93.5	93	70	81	86	6309	6208	E1	589,03 (23.19)	CD0180
11	15	1765	254JP	EJPM2513T	17.7	211	60,74 (44.8)	93.7	93.7	93	82	88	90	6309	6208	E	661,92 (26.06)	CD0180
15	20	3510	254JM	EJMM2514T	23.5	153	40,13 (29.6)	90.1	91.2	91	74	83	87	6309	6208	E1	589,03 (23.19)	CD0180
15	20	3525	254JP	EJPM2514T	23.5	139	40,67 (30)	91.4	91.8	91	80	86	88	6309	6208	E1	661,92 (26.06)	CD0180
15	20	1765	256JM	EJMM2515T	23.5	160.8	80,54 (59.4)	92.5	93.2	93	71	81	86	6309	6208	E1	589,03 (23.19)	CD0180
15	20	1765	256JP	EJPM2515T	23.5	160.8	80,54 (59.4)	92.5	93.2	93	71	81	86	6309	6208	E1	661,92 (26.06)	CD0180
19	25	3515	256JM	EJMM2516T	28	197	50,44 (37.2)	91.8	92.3	91.7	79	86	89	6309	6208	E1	589,03 (23.19)	CD0180
19	25	3530	256JP	EJPM2516T	29	204	50,17 (37)	93.2	92.9	91.7	77	83	87	6309	6208	E1	661,92 (26.06)	CD0180
19	25	1760	284JM	EJMM2531T	29	180	100,33 (74)	93.2	93.9	93.6	72	82	86	6312	6309	F	627,13 (24.69)	CD0180
19	25	1760	284JP	EJPM2531T	29	180	100,33 (74)	93.2	93.9	93.6	72	82	86	6312	6309	E1	700,28 (27.57)	CD0180
22	30	3510	284JM	EJMM2534T	33	207	61,01 (45)	92.5	92.6	91.7	87	91	92	6312	6208	F	674,62 (26.56)	CD0005
22	30	3510	284JP	EJPM2534T	33	207	61,01 (45)	92.5	92.6	91.7	87	91	92	6312	6208	F	747,78 (29.44)	CD0005
22	30	1770	286JM	EJMM2535T	35	223.6	120,53 (88.9)	93.6	94.2	94.1	72	82	85	6312	6309	F	658,88 (25.94)	CD0005
22	30	1770	286JP	EJPM2535T	35	223.6	120,53 (88.9)	93.6	94.2	94.1	72	82	85	6312	6309	E1	732,03 (28.82)	CD0005
30	40	3510	286JM	EJMM2538T	45	326	82,30 (60.7)	94.1	93.8	92.4	82	88	90	6312	6208	F	674,62 (26.56)	CD0180
30	40	3510	286JP	EJPM2538T	45	326	82,30 (60.7)	94.1	93.8	92.4	82	88	90	6312	6208	F	747,78 (29.44)	CD0180
30	40	1770	324JM	EJMM2539T	49	330	161,34 (119)	94	94.5	94.1	65	76	82	6312	6309	F	696,98 (27.44)	CD0005
30	40	1775	324JP	EJPM2539T	47	280	159,99 (118)	93.6	94.4	94.1	76	82	84	6312	6311	E1	757,43 (29.82)	CD0180
37	50	3530	324JM	EJMM2542T	55	408	100,60 (74.2)	94.7	94.8	93	82	87	90	6312	6309	E	696,98 (27.44)	CD0180
37	50	3530	324JP	EJPM2542T	55	408	100,60 (74.2)	94.7	94.8	93	82	87	90	6312	6309	F	769,87 (30.31)	CD0180
37	50	1775	326JM	EJMM2543T	57	378	200,66 (148)	94.5	94.9	94.5	75	84	87	6312	6311	F	709,68 (27.94)	CD0180
37	50	1775	326JP	EJPM2543T	57	378	200,66 (148)	94.5	94.9	94.5	75	84	87	6312	6311	E1	782,83 (30.82)	CD0180
C-face footless																		
0,75	1	1760	143JM	VEJMM3116T	1.5	12.1	4,07 (3)	82.1	84.8	85.5	49	62	71	6206	6203	E	366,52 (14.43)	CD0005
1,1	1 1/2	1755	145JM	VEJMM3154T	2.2	17.5	6,10 (4.5)	83.5	86	86.5	50	63	72	6206	6203	F	391,92 (15.43)	CD0005
1,5	2	1750	145JM	VEJMM3157T	2.9	24.3	8,13 (6)	84.4	86.6	86.5	51	64	73	6206	6203	F	391,92 (15.43)	CD0005
2,2	3	1765	184JM	VEJMM3211T	4.2	32.3	12,07 (8.9)	87.5	89.5	89.5	53	66	73	6207	6205	E1	458,72 (18.06)	CD0005
3,7	5	1750	184JM	VEJMM3218T	6.6	44.8	20,34 (15)	89.7	90.2	89.5	64	75	80	6207	6205	E	496,82 (19.56)	CD0005
5,6	7 1/2	1770	213JM	VEJMM3311T	9.6	67.5	30,10 (22.2)	89.6	91.5	91	61	74	80	6309	6206	E1	502,41 (19.78)	CD0005
7,5	10	1770	215JM	VEJMM3313T	12	100	36,06 (26.6)	92.4	92.3	91.7	63	77	84	6309	6206	E	569,21 (22.41)	CD0005

Notes: Volt code: E = 208-230/460V, 60 Hz; E1 = 230/460V, 60 Hz, usable at 208V; F = 230/460V, 60 Hz

See pages 52 and 53 for layout drawings. See pages 58 and 60 for connection diagrams.

Efficiencies shown are nominal. Data subject to change without notice. Contact your ABB regional support office for certified data.

NEMA Super-E[®] premium efficient motors

Vertical P-base – TEFC – normal thrust



These solid shaft motors are ideal for normal thrust in-line pump applications, including aerators for wastewater treatment plants, petroleum refineries, chemical plants, pulp and paper mills, and agriculture irrigation. Features include 1.15 service factor, cast iron frame, corrosion resistant epoxy finish, shaft seals, and dual lifting lugs. Motors are NEMA Premium[®] efficiency and are inverter ready. Motors have severe duty features.

TEFC – totally enclosed fan cooled, 230/460 volts, three phase, 2.2 - 56 kW (3 - 75 hp)

kW	Hp	RPM	Frame	Catalog number	Amps @ high V		F.L. torque Nm (lb-ft)	Efficiency %			Power factor %			Bearings		Max thrust load lbs.	Volt code	"C" dim. mm (in)	Conn. diag. no.
					F.L.	L.R.		1/2	3/4	F.L.	1/2	3/4	F.L.	DE	ODE				
2,2	3	3500	182HP*	VHECP3660T	3.5	37.6	6,10 (4.5)	87.9	89.6	89.5	73	84	89	6307	6206	420	E1	563,37 (22.18)	CD0005
2,2	3	1755	182HP*	VHECP3661T	4.1	29.8	12,34 (9.1)	88.9	90.1	89.5	58	70	77	6307	6206	563	E	563,37 (22.18)	CD0005
3,7	5	3490	184HP*	VHECP3663T	5.7	64.8	10,17 (7.5)	89.4	90.8	90.2	76	85	90	6307	6206	420	E1	563,37 (22.18)	CD0005
3,7	5	1750	184HP*	VHECP3665T	6.5	54	20,20 (14.9)	90.3	91.2	90.2	60	73	80	6307	6206	563	E1	563,37 (22.18)	CD0005
5,6	7 1/2	3525	213HP*	VHECP3769T	8.6	75	15,19 (11.2)	90	91.4	91	79	87	90	6309	6206	650	E1	567,18 (22.33)	CD0005
5,6	7 1/2	1770	213HP*	VHECP3770T	9.5	68	29,96 (22.1)	91.6	92.3	91.7	65	76	81	6309	6206	563	E1	567,18 (22.33)	CD0005
7,5	10	3500	215HP*	VHECP3771T	11.2	120	20,34 (15)	92.7	92.9	91.7	82	89	92	6309	6206	760	E1	567,18 (22.33)	CD0005
7,5	10	1760	215HP*	VHECP3774T	12.5	88.5	40,40 (29.8)	92.9	93.1	92.4	67	78	82	6309	6206	563	E1	567,18 (22.33)	CD0005
11	15	3525	254HP*	VHECP2394T	17.2	128	30,10 (22.2)	90.8	91.9	91.7	78	86	88	6311	6208	895	E1	653,54 (25.73)	CD0180
11	15	1765	254HP*	VHECP2333T	18.5	122.9	60,47 (44.6)	91.9	92.6	92.4	66	77	82	6311	6208	1180	E1	653,54 (25.73)	CD0005
15	20	3540	256HP*	VHECP4106T	23	201	40,27 (29.7)	91.1	92.3	92.4	74	84	89	6311	6208	895	E1	653,54 (25.73)	CD0180
15	20	1765	256HP*	VHECP2334T	24	175	79,99 (59)	92.8	93.1	93	69	80	84	6311	6208	1180	E1	653,54 (25.73)	CD0005
19	25	3530	284HP*	VHECP4107T	28	236	50,44 (37.2)	93	93.5	93	82	89	91	6311	6208	895	E1	653,29 (25.72)	CD0180
19	25	1770	284HP*	VHECP4103T	30	186	100,60 (74.2)	92.3	93.5	93.6	73	81	85	6311	6309	1180	E1	779,53 (30.69)	CD0005
22	30	3520	286HP*	VHECP4108T	33	281	60,61 (44.7)	93.2	93.5	93	83	89	92	6311	6208	895	E1	653,29 (25.72)	CD0180
22	30	1770	286HP*	VHECP4104T	36	246	120,67 (89)	93.8	94.4	94.1	66	75	83	6311	6309	1180	E1	779,53 (30.69)	CD0005
30	40	3540	324HP*	VHECP4109T	45	326	80,67 (59.5)	92.3	93.4	93.6	80	87	90	6312	6311	760	E1	881,89 (34.72)	CD0180
30	40	1775	324HP*	VHECP4110T	46	320	159,99 (118)	93.9	94.6	94.5	73	81	84	6312	6311	1360	E1	881,89 (34.72)	CD0180
37	50	3540	326HP*	VHECP4114T	56	403	100,47 (74.1)	94	94.5	94.1	80	87	89	6312	6311	760	E	881,89 (34.72)	CD0180
37	50	1775	326HP*	VHECP4115T	57	392	202,02 (149)	94.4	94.9	94.5	73	82	85	6312	6211	1360	E1	881,89 (34.72)	CD0180
45	60	3560	364HP*	VHECP4310T	65.1	398	119,99 (88.5)	95.3	95.5	95	88	91	91	6313	6313	1500	E1	895,35 (35.25)	416820-2
45	60	1780	364HP*	VHECP4314T	68	430	239,98 (177)	95.2	95.3	95	79	85	87	6313	6313	2000	E1	895,35 (35.25)	416820-2
56	75	3555	365HP*	VHECP4313T	80.7	494	150,50 (111)	95.1	95.4	95	91	92	92	6313	6313	1500	E1	895,35 (35.25)	416820-2
56	75	1780	365HP*	VHECP4316T	85.9	542	299,64 (221)	95.7	95.8	95.4	77	84	86	6313	6313	2000	E1	895,35 (35.25)	416820-2

Notes: Volt code: E = 208-230/460V, 60 Hz; E1 = 230/460V, 60 Hz, usable at 208V

* Ratings are cast iron frames.

See page 49 for layout drawing. See pages 58 and 60 for connection diagrams.

Efficiencies shown are nominal. Data subject to change without notice. Contact your ABB regional support office for certified data.

NEMA Super-E[®] premium efficient motors

HVAC motors – TEFC



These motors are used in heating, ventilation and air conditioning blower and fan motors in applications suitable for an enclosed motor design. Designed and manufactured with heavy-gauge steel frame construction, ball bearings, grease passages have plugs. Dynamically balanced rotors provide reduced vibration and quiet operation. They are suitable for mounting in any position and includes lifting provisions on all frame sizes. A bar-coded spec number label is included for convenience. All models meet NEMA Premium[®] efficiencies and have class F insulation with a 1.15 service factor. Motors are inverter ready and have a 3-year warranty.



TEFC – totally enclosed fan cooled, foot mounted, three phase, 0.75 - 75 kW (1 - 100 hp)

kW	Hp	RPM	Frame	Catalog number	Amps @ high V		FL. torque Nm (lb-ft)	Efficiency %			Power factor %			Bearings		Volt code	"C" dim. mm (in)	Conn. diag. no.
					FL.	L.R.		1/2	3/4	FL.	1/2	3/4	FL.	DE	ODE			
230/460 volts																		
0.75	1	1760	143T	EHM3546T	1.5	12.1	4.03 (2.97)	82.1	84.8	85.5	49	62	71	6205	6203	E	312,67 (12.31)	CD0005
1.1	1 1/2	1760	145T	EHM3554T	2.2	18.3	6.06 (4.47)	84.5	86.8	86.5	51	65	73	6205	6203	E	337,57 (13.29)	CD0005
1.5	2	1750	145T	EHM3558T	2.9	23.7	8.15 (6.01)	85.4	86.9	86.5	53	67	75	6205	6203	E	337,57 (13.29)	CD0005
2.2	3	1760	182T	EHM3611T	4.2	32	12,04 (8.88)	87.8	89.5	89.5	54	68	75	6206	6205	E	420,12 (16.54)	CD0005
3.7	5	1750	184T	EHM3615T	6.7	49.1	20,20 (14.9)	89.7	90.3	89.5	60	72	78	6206	6205	E	458,22 (18.04)	CD0005
5.6	7 1/2	1770	213T	EHM3710T	9.4	71.6	30,10 (22.2)	91.8	92.4	91.7	62	75	81	6307	6206	E	483,36 (19.03)	CD0005
7.5	10	1770	215T	EHM3714T	12	103	40,00 (29.5)	92.1	92.4	91.7	66	79	85	6307	6206	E	521,46 (20.53)	CD0005
11	15	1765	254T*	EHM2333T	18.5	122.9	60,47 (44.6)	91.9	92.6	92.4	66	77	82	6309	6208	E	588,26 (23.16)	CD0005
15	20	1765	256T*	EHM2334T	24	175	79,99 (59)	92.8	93.1	93	69	80	84	6309	6208	E	588,26 (23.16)	CD0005
19	25	1780	284T*	EHM4103T	30	188	100,33 (74)	93.4	93.9	93.6	68	78	83	6311	6309	E	705,10 (27.76)	CD0005
22	30	1770	286T*	EHM4104T	38	274	120,53 (88.9)	93.4	94.2	93.6	60	70	79	6311	6309	E	705,10 (27.76)	CD0005
30	40	1775	324T*	EHM4110T	48	370	159,99 (118)	93.7	94.6	94.1	66	76	82	6312	6311	E	769,11 (30.28)	CD0180
37	50	1775	326T*	EHM4115T	57	392	202,02 (149)	94.4	94.9	94.5	73	82	85	6312	6311	E1	769,11 (30.28)	CD0180
575 volt																		
0.75	1	1760	143T	EHM3546T-5	1.2	9.66	4.03 (2.97)	81.9	84.8	85.5	49	62	71	6205	6203	H	312,67 (12.31)	CD0006
1.1	1 1/2	1760	145T	EHM3554T-5	1.8	14.6	6.06 (4.47)	84.5	87	86.5	51	65	74	6205	6203	H	337,57 (13.29)	CD0006
1.5	2	1755	145T	EHM3558T-5	2.4	19.6	8.07 (5.95)	83.8	86.4	86.5	50	64	73	6205	6203	H	360,43 (14.19)	CD0006
2.2	3	1760	182T	EHM3611T-5	3.3	25.9	12,04 (8.88)	87.7	89.5	89.5	54	67	75	6206	6205	H	420,12 (16.54)	CD0006
3.7	5	1750	184T	EHM3615T-5	5.3	39.3	20,20 (14.9)	89.6	90.5	89.5	60	72	78	6206	6205	H	458,22 (18.04)	CD0006
5.6	7 1/2	1770	213T	EHM3710T-5	7.6	58.5	30,10 (22.2)	91.1	92.3	91.7	61	74	81	6307	6206	H	483,36 (19.03)	CD0006
7.5	10	1770	215T	EHM3714T-5	9.6	83.9	40,00 (29.5)	92	92.7	91.7	65	78	85	6307	6206	H	521,46 (20.53)	CD0006
11	15	1765	254T*	EHM2333T-5	14.8	99	60,33 (44.5)	91.3	92.5	92.4	67	78	82	6309	6208	H	588,26 (23.16)	CD0006
15	20	1765	256T*	EHM2334T-5	19.2	140	79,99 (59)	92.8	93.1	93	69	80	84	6309	6208	H	588,26 (23.16)	CD0006
19	25	1770	284T*	EHM4103T-5	23.9	153	100,47 (74.1)	92.4	93.5	93.6	71	80	84	6311	6309	H	705,10 (27.76)	CD0006
22	30	1770	286T*	EHM4104T-5	29	177	120,94 (89.2)	93.9	94.4	93.6	69	77	84	6311	6309	H	705,10 (27.76)	CD0006
30	40	1775	324T*	EHM4110T-5	39	267	159,99 (118)	93.6	94.3	94.1	67	77	82	6312	6311	H	769,11 (30.28)	CD0006
37	50	1775	326T*	EHM4115T-5	45.6	318	202,02 (149)	94.4	94.9	94.5	81	80	88	6312	6311	H	769,11 (30.28)	CD0006
200 Volt																		
11	15	1765	254T	EHF2523T-8	40.7	40.7	60,47 (44.6)	93.3	93.5	93	70	81	86	6309	6208	200	550.93 (21.69)	CD0695

Notes: Volt code: E = 208-230/460V, 60 Hz; E1 = 230/460V, 60 Hz, usable at 208V; H = 575V, 60 Hz

* Ratings are cast iron frames.

See pages 41 and 42 for layout drawings. See pages 58 and 60 for connection diagrams.

Efficiencies shown are nominal. Data subject to change without notice. Contact your ABB regional support office for certified data.

NEMA Super-E[®] premium efficient motors

HVAC motors – TEFC – with AEGIS[®] bearing protection ring



Designed and manufactured for heating, ventilation and air conditioning blower and fan motors, pump motors, and other general purpose applications using an adjustable speed drive.

These motors are manufactured with AEGIS[®] bearing protection ring installed internally. They have regreaseable ball bearings. Motors have dynamically balanced rotors for reduced vibration and quiet operation and are suitable for mounting in any position. All models meet or exceed NEMA Premium[®] efficiencies and have a class H insulation system and 1.15 service factor. Motors are inverter ready, and have a 3-year warranty.



TEFC – totally enclosed fan cooled, foot mounted, 230/460 volts, three phase, 0.75 - 75 kW (1 - 100 hp)

kW	Hp	RPM	Frame	Catalog number	Amps @ high V		F.L. torque Nm (lb-ft)	Efficiency %		Power factor %			Bearings		Volt code	"C" dim. mm (in)	Conn. diag. no.	Notes	
					F.L.	L.R.		1/2	3/4	F.L.	1/2	3/4	F.L.	DE					ODE
230/460 volts																			
0.75	1	3450	56	EM3545-G	1.4	9	2,03 (1.5)	67.8	73.1	77	74	2	87	6205	6203	F	310,64 (12.23)	CD0005	-
0.75	1	1760	143T	EM3546T-G	1.5	12.1	4,03 (2.97)	81.9	84.8	85.5	49	62	71	6205	6203	E	312,67 (12.31)	CD0005	-
0.75	1	1155	145T	EM3556T-G	1.8	10.8	6,11 (4.51)	79.4	82.1	82.5	43	55	64	6205	6203	E	338,07 (13.31)	CD0005	-
1.1	1 1/2	3500	143T	EM3550T-G	1.9	17.9	3,01 (2.22)	82.2	84.4	84	67	79	85	6205	6203	E	312,17 (12.29)	CD0005	-
1.1	1 1/2	1760	145T	EM3554T-G	2.2	18.3	6,06 (4.47)	84.5	86.9	86.5	51	65	73	6205	6203	E	338,07 (13.31)	CD0005	-
1.1	1 1/2	1165	182T	EM3607T-G	2.4	15.8	9,30 (6.86)	86	87.5	87.5	48	59	67	6206	6205	E	420,12 (16.54)	CD0005	-
1.5	2	3490	145T	EM3555T-G	2.5	25.9	4,04 (2.98)	83.5	85.9	85.5	75	84	88	6205	6203	E	337,57 (13.29)	CD0005	-
1.5	2	1755	145T	EM3558T-G	2.9	24.3	8,07 (5.95)	84	86.5	86.5	51	64	73	6205	6203	E	360,43 (14.19)	CD0005	-
1.5	2	1175	184T	EM3614T-G	3.5	27.5	12,08 (8.91)	85.3	88	88.5	40	52	60	6206	6205	E	458,22 (18.04)	CD0005	-
2.2	3	3450	145T	EM3559T-G	3.5	39.2	6,22 (4.59)	87.7	88.3	87.5	81	88	92	6205	6203	E	394,72 (15.54)	CD0005	-
2.2	3	3450	182T	EM3610T-G	3.6	33	6,10 (4.5)	87.9	88.2	86.5	81	88	92	6206	6203	E	385,32 (15.17)	CD0005	-
2.2	3	1760	182T	EM3611T-G	4.2	32	12,04 (8.88)	87.8	89.6	89.5	55	68	75	6206	6205	E	420,12 (16.54)	CD0005	-
2.2	3	1160	213T	EM3704T-G	4.6	34.4	18,17 (13.4)	87.7	89.4	89.5	49	61	68	6307	6206	F	482,85 (19.01)	CD0005	-
3.7	5	3450	184T	EM3613T-G	5.9	57.2	10,36 (7.64)	88.9	89.4	88.5	81	88	91	6206	6205	F	420,12 (16.54)	CD0005	-
3.7	5	1750	184T	EM3615T-G	6.7	49.1	20,20 (14.9)	89.7	90.6	89.5	60	72	78	6206	6205	E	458,22 (18.04)	CD0005	-
3.7	5	1160	215T	EM3708T-G	7.3	51.6	30,78 (22.7)	89.8	90.3	89.5	55	66	72	6307	6206	E	501,90 (19.76)	CD0005	-
5.6	7 1/2	3520	213T	EM3709T-G	9	68.4	14,78 (10.9)	88.8	90.5	89.5	69	79	84	6307	6206	E	454,41 (17.89)	CD0005	-
5.6	7 1/2	1770	213T	EM3710T-G	9.4	71.6	30,23 (22.3)	91.6	92.4	91.7	62	75	81	6307	6206	E1	482,85 (19.01)	CD0005	-
5.6	7 1/2	1180	254T*	EM2276T-G	10.7	67	43,93 (32.4)	89.3	90.7	91	53	64	70	6309	6208	E1	588,26 (23.16)	CD0005	-
7.5	10	3490	215T	EM3711T-G	11.8	78.5	20,34 (15)	91	91.3	90.2	74	84	87	6307	6206	E	454,41 (17.89)	CD0005	-
7.5	10	1770	215T	EM3714T-G	12	100	36,06 (26.6)	92.4	92.3	91.7	63	77	84	6307	6206	E	520,95 (20.51)	CD0005	-
7.5	10	1180	256T*	EM2332T-G	14.4	95.1	60,20 (44.4)	89.9	91.3	91	55	65	71	6309	6208	E1	588,26 (23.16)	CD0180	-
11	15	3520	254T*	EM2394T-G	17.5	110	29,96 (22.1)	91	91.6	91	77	85	87	6309	6208	E1	588,26 (23.16)	CD0180	-
11	15	1765	254T*	EM2333T-G	18.5	122.9	60,47 (44.6)	91.9	92.6	92.4	66	77	82	6309	6208	E1	588,26 (23.16)	CD0005	-
11	15	1175	284T*	EM4100T-G	21	125	90,16 (66.5)	90.6	91.8	91.7	54	66	73	6311	6309	E1	705,10 (27.76)	CD0180	-
15	20	3520	256T*	EM4106T-G	23	161	40,13 (29.6)	92.2	92.4	91	78	86	89	6309	6208	E1	588,26 (23.16)	CD0005	-
15	20	1765	256T*	EM2334T-G	24	175	79,99 (59)	92.8	93.1	93	69	80	84	6309	6208	E1	588,26 (23.16)	CD0005	-
15	20	1180	286T*	EM4102T-G	27	165	121,21 (89.4)	91.1	91.9	91.7	60	71	77	6311	6309	E	705,10 (27.76)	CD0180	-
19	25	3525	284TS*	EM4107T-G	29	249	50,17 (37)	89.2	91.2	91.7	75	83	90	6311	6208	F	627,38 (24.7)	CD0005	-
19	25	1770	284T*	EM4103T-G	30	187.6	100,60 (74.2)	92.4	93.6	93.6	72	81	84	6311	6309	E1	705,10 (27.76)	CD0005	-
19	25	1180	324T*	EM4111T-G	32	220	151,85 (112)	92.6	93.3	93	63	73	79	6312	6309	E1	771,91 (30.39)	CD0180	-
22	30	3520	286TS*	EM4108T-G	34	288	60,33 (44.5)	90.8	91.9	91.7	81	87	90	6311	6208	F	627,38 (24.7)	CD0180	-
22	30	1760	286T*	EM4104T-G	38	270	120,26 (88.7)	92.3	93.5	93.6	63	73	80	6311	6309	F	705,10 (27.76)	CD0180	-
22	30	1180	326T*	EM4117T-G	39	243	180,32 (133)	92.5	93.2	93	62	73	78	6312	6311	E1	769,11 (30.28)	CD0005	-
30	40	3530	324TS*	EM4109T-G	46	305	80,26 (59.2)	91.6	92.6	92.4	79	86	88	6312	6311	E1	733,30 (28.87)	CD0180	-
30	40	1770	324T*	EM4110T-G	48	349	159,99 (118)	93.7	94.5	94.1	69	79	83	6312	6311	E1	769,11 (30.28)	CD0180	-
30	40	1190	364T*	EM4308T-G	49.4	290	239,98 (177)	93.6	94.3	94.1	69	77.2	80.5	6313	6313	F	849,38 (33.44)	416820-2	-
37	50	3540	326TS*	EM4114T-G	56	408	100,87 (74.4)	93.8	94.2	93	82	88	90	6312	6311	E	733,30 (28.87)	CD0180	-
37	50	1775	326T*	EM4115T-G	58	395	199,31 (147)	94.3	94.8	94.5	74	83	85	6312	6311	F	769,11 (30.28)	CD0180	-
37	50	1185	365T*	EM4312T-G	61.7	345	299,64 (221)	93.9	94.4	94.1	70	77.8	80.6	6313	6313	F	849,38 (33.44)	416820-2	-
45	60	3560	364TS*	EM4310T-G	66.3	398	119,99 (88.5)	95.3	95.5	95	88.2	90.7	90.7	6313	6313	F	795,27 (31.31)	416820-2	-
45	60	1780	364T*	EM4314T-G	68	430	239,98 (177)	95.2	95.3	95	78.7	85	87	6313	6313	F	849,38 (33.44)	416820-2	-
56	75	3555	365TS*	EM4313T-G	81.9	494	150,50 (111)	95.1	95.4	95	90.8	92.1	91.5	6313	6313	F	795,27 (31.31)	416820-2	-
56	75	1780	365T*	EM4316T-G	85.9	542	299,64 (221)	95.7	95.8	95.4	77	83.5	85.6	6313	6313	F	849,38 (33.44)	416820-2	-
75	100	1785	405T*	EM4400T-G	112	725	399,97 (295)	95.4	95.7	95.4	82.5	86.7	87.4	6316	6316	F	973,07 (38.31)	416820-2	-

Notes: Volt code: E = 208-230/460V, 60 Hz; E1 = 230/460V, 60 Hz, usable at 208V; F = 230/460V

* Ratings are cast iron frames.

See pages 40 and 41 for layout drawings. See pages 58 and 60 for connection diagrams.

Efficiencies shown are nominal. Data subject to change without notice. Contact your ABB regional support office for certified data.

NEMA Super-E[®] premium efficient motors

HVAC motors – TEFC – with AEGIS[®] bearing protection ring



Designed and manufactured for heating, ventilation and air conditioning blower and fan motors, pump motors, and other general purpose applications using an adjustable speed drive.

These motors are manufactured with AEGIS[®] bearing protection ring installed internally. They have regreaseable ball bearings. Motors have dynamically balanced rotors for reduced vibration and quiet operation and are suitable for mounting in any position. All models meet or exceed NEMA Premium[®] efficiencies and have a class H insulation system and 1.15 service factor. Motors are inverter ready, and have a 3-year warranty.



TEFC – totally enclosed fan cooled, foot mounted, 575 volts, three phase, 0.75 - 37 kW (1 - 50 hp)

kW	Hp	RPM	Frame	Catalog number	Amps @ high V F.L.			Efficiency %			Power factor %			Bearings		Volt Code	"C" dim. mm (in)	Conn. diag. no.	Notes
					F.L.	L.R.	torque Nm (lb-ft)	1/2	3/4	F.L.	1/2	3/4	F.L.	DE	ODE				
575 volts																			
0,75	1	1760	143T	EM3546T-5G	1.2	9.66	4,03 (2.97)	81.9	84.8	85.5	49	62	71	6205	6203	H	312,67 (12.31)	CD0006	-
1,1	1 1/2	1760	145T	EM3554T-5G	1.8	14.6	6,06 (4.47)	84.5	87	86.5	51	65	73	6205	6203	H	338,07 (13.31)	CD0006	-
1,5	2	1755	145T	EM3558T-5G	2.4	19.6	8,07 (5.95)	83.8	86.4	86.5	50	64	73	6205	6203	H	360,43 (14.19)	CD0006	-
2,2	3	1760	182T	EM3611T-5G	3.3	25.9	12,04 (8.88)	87.7	89.5	89.5	54	67	75	6206	6205	H	420,12 (16.54)	CD0006	-
3,7	5	1750	184T	EM3615T-5G	5.3	39.3	20,20 (14.9)	89.6	90.5	89.5	60	72	78	6206	6205	H	458,22 (18.04)	CD0006	-
5,6	7 1/2	1770	213T	EM3710T-5G	7.6	58.5	30,10 (22.2)	91.1	92.3	91.7	61	74	81	6307	6206	H	482,85 (19.01)	CD0006	35
7,5	10	1770	215T	EM3714T-5G	9.6	83.9	40,00 (29.5)	92	92.7	91.7	65	78	85	6307	6206	H	520,95 (20.51)	CD0006	35
11	15	1765	254T*	EM2333T-5G	14.8	99	60,33 (44.5)	91.3	92.5	92.4	67	78	82	6309	6208	H	588,26 (23.16)	CD0006	-
15	20	1765	256T*	EM2334T-5G	19.2	140	79,99 (59)	92.8	93.1	93	69	80	84	6309	6208	H	588,26 (23.16)	CD0006	-
19	25	1770	284T*	EM4103T-5G	23.9	153	100,47 (74.1)	92.4	93.5	93.6	71	80	84	6311	6309	H	705,10 (27.76)	CD0006	-
22	30	1770	286T*	EM4104T-5G	29	177	120,94 (89.2)	93.9	94.4	93.6	69	77	83	6311	6309	H	705,10 (27.76)	CD0006	-
30	40	1775	324T*	EM4110T-5G	39	267	159,99 (118)	93.6	94.3	94.1	67	77	82	6312	6311	H	769,11 (30.28)	CD0006	-
37	50	1775	326T*	EM4115T-5G	46	330	199,31 (147)	95.4	95	94.5	72	82	85	6312	6311	H	769,11 (30.28)	CD0006	35

Notes: 35 = Design A motor

Volt code: H = 575V

* Ratings are cast iron frames.

See pages 40 and 41 for layout drawings. See page 58 for connection diagrams.

Efficiencies shown are nominal. Data subject to change without notice. Contact your ABB regional support office for certified data.

NEMA Super-E[®] premium efficient motors

HVAC motors – ODP



These motors are used in heating, ventilation and air conditioning blower and fan applications suitable for an open motor design. Designed with heavy-gauge steel frame construction, ball bearings, grease passages have plugs. The motors have dynamically balanced rotors for reduced vibration and quiet operation. They are suitable for mounting in any position and include lifting provisions on all frame sizes. A bar-coded spec number label is included for convenience. All models meet NEMA Premium[®] efficiencies and have class F insulation with 1.15 service factor that operates within class “B” temperature limits at rated horsepower. Motors are inverter ready and have a 3-year warranty.



ODP – open drip proof – foot mounted, three phase, 0.75 - 75 kW (1 - 100 hp)

kW	Hp	RPM	Frame	Catalog number	Amps @ high V		F.L. torque Nm (lb-ft)	Efficiency %			Power factor %			Bearings		Volt code	“C” dim. mm (in)	Conn. diag. no.
					F.L.	L.R.		1/2	3/4	F.L.	1/2	3/4	F.L.	DE	ODE			
F1 mount, 230/460 volt																		
0.75	1	1760	143T	EHM3116T	1.5	12.1	4,07 (3)	82.1	84.8	85.5	49	62	71	6205	6203	E	282,45 (11.12)	CD0005
1.1	1 1/2	1755	145T	EHM3154T	2.2	17.5	6,10 (4.5)	83.5	86	86.5	50	63	72	6205	6203	E1	295,15 (11.62)	CD0005
1.5	2	1750	145T	EHM3157T	2.9	24.3	8,13 (6)	84.4	86.6	86.5	51	64	73	6205	6203	E1	308,10 (12.13)	CD0005
2.2	3	1765	182T	EHM3211T	4.2	32.3	12,07 (8.9)	87.5	89.5	89.5	53	66	73	6206	6205	E1	381,00 (15)	CD0005
3.7	5	1750	184T	EHM3218T	6.6	44.8	20,34 (15)	89.7	90.2	89.5	64	75	80	6206	6205	E	419,10 (16.5)	CD0005
3.7	5	1750	184T	EHM3218TA	6.6	44.8	20,34 (15)	89.8	90.2	89.5	63	75	80	6206	6205	E	419,10 (16.5)	CD0007
5.6	7 1/2	1770	213T	EHM3311T	9.7	68.2	29,96 (22.1)	90.5	91.4	91	62	73	79	6307	6206	E	414,53 (16.32)	CD0005
7.5	10	1770	215T	EHM3313T	12.5	88.3	40,27 (29.7)	91.6	92.3	91.7	66	77	82	6307	6206	E	443,23 (17.45)	CD0005
11	15	1765	254T	EHM2523T	17.7	211	60,74 (44.8)	93.7	93.7	93	82	88	90	6309	6208	E	550,93 (21.69)	CD0180
15	20	1765	256T	EHM2515T	23.5	160.8	80,54 (59.4)	92.5	93.2	93	71	81	86	6309	6208	E1	550,93 (21.69)	CD0180
19	25	1760	284T	EHM2531T	29	180	100,33 (74)	93.2	93.9	93.6	72	82	86	6311	6309	E1	604,77 (23.81)	CD0180
22	30	1770	286T	EHM2535T	35	223.6	120,53 (88.9)	93.6	94.2	94.1	72	82	85	6311	6309	E1	636,52 (25.06)	CD0005
30	40	1775	324T	EHM2539T	46	302	159,99 (118)	94.2	94.8	94.1	69	79	85	6312	6311	E1	677,93 (26.69)	CD0005
37	50	1775	326T	EHM2543T	57	378	200,66 (148)	94.5	94.9	94.5	75	84	87	6312	6311	E1	703,33 (27.69)	CD0180
45	60	1775	364T	EHM2547T	68	464	239,98 (177)	94.9	95.3	95	77	85	88	6313	6311	E	760,48 (29.94)	CD0005
56	75	1775	365T	EHM2551T	87	512	300,99 (222)	95.5	95.7	95	78	84	87	6313	6312	F	856,49 (33.72)	CD0180
75	100	1780	404T	EHM2555T	113	725	399,97 (295)	95.4	95.8	95.4	72	81	87	6316	6312	E	939,04 (36.97)	CD0180
F2 mount, 230/460 volt																		
0.75	1	1760	143T	EHF3116T	1.5	12.1	4,07 (3)	82.1	84.8	85.5	49	62	71	6205	6203	E	282,45 (11.12)	CD0005
1.1	1 1/2	1755	145T	EHF3154T	2.2	17.5	6,10 (4.5)	83.5	86	86.5	50	63	72	6205	6203	E1	295,15 (11.62)	CD0005
1.5	2	1725	145T	EHF3157T	2.7	19.6	8,13 (6)	87.9	88.3	86.5	63	74	80	6205	6203	E	330,20 (13)	CD0005
2.2	3	1765	182T	EHF3211T	4.2	32.3	12,07 (8.9)	87.5	89.5	89.5	53	66	73	6206	6205	E1	381,00 (15)	CD0005
3.7	5	1750	184T	EHF3218T	6.6	44.8	20,34 (15)	89.7	90.2	89.5	64	75	80	6206	6205	E	419,10 (16.5)	CD0005
5.6	7 1/2	1770	213T	EHF3311T	9.7	68.2	29,96 (22.1)	90.5	91.4	91	62	73	79	6307	6206	E	414,53 (16.32)	CD0005
7.5	10	1770	215T	EHF3313T	12.5	88.3	40,27 (29.7)	91.6	92.3	91.7	66	77	82	6307	6206	E	443,23 (17.45)	CD0005
11	15	1765	254T	EHF2523T	17.7	211	60,74 (44.8)	93.7	93.7	93	82	88	90	6309	6208	E	550,93 (21.69)	CD0180
15	20	1765	256T	EHF2515T	23.5	160.8	80,54 (59.4)	92.5	93.2	93	71	81	86	6309	6208	E1	550,93 (21.69)	CD0180
19	25	1760	284T	EHF2531T	29	180	100,33 (74)	93.2	93.9	93.6	72	82	86	6311	6309	E1	604,77 (23.81)	CD0180
22	30	1770	286T	EHF2535T	35	223.6	120,53 (88.9)	93.6	94.2	94.1	72	82	85	6311	6309	E1	636,52 (25.06)	CD0005
30	40	1770	324T	EHF2539T	49	330	161,34 (119)	94	94.5	94.1	65	76	82	6312	6309	E1	690,63 (27.19)	CD0005
37	50	1775	326T	EHF2543T	57	378	200,66 (148)	94.5	94.9	94.5	75	84	87	6312	6311	E1	703,33 (27.69)	CD0180
45	60	1775	364T	EHF2547T	68	470	239,98 (177)	94.9	95.3	95	77	85	87	6313	6311	E1	779,53 (30.69)	CD0180
56	75	1775	365T	EHF2551T	87	512	300,99 (222)	95.5	95.7	95	78	84	87	6313	6312	F	856,49 (33.72)	CD0180
75	100	1780	404T	EHF2555T	113	725	399,97 (295)	95.4	95.8	95.4	72	81	87	6316	6312	E	939,04 (36.97)	CD0180
F1 mount, 200 volt																		
0.75	1	1760	143T	EHM3116T-8	3.5	3.5	4,03 (2.97)	82.3	84.6	85.5	50	62	71	6205	6203	200	282,45 (11.12)	CD0006
1.1	1 1/2	1755	145T	EHM3154T-8	5.1	5.1	6,05 (4.46)	83.1	85.9	86.5	51	64	73	6205	6203	200	295,15 (11.62)	CD0006
1.5	2	1750	145T	EHM3157T-8	6.5	6.5	8,19 (6.04)	84.5	86.5	86.5	56	69	77	6205	6203	200	308,10 (12.13)	CD0006
2.2	3	1765	182T	EHM3211T-8	9.7	9.7	12,00 (8.85)	87.4	89.4	89.5	53	66	73	6206	6205	200	381,00 (15)	CD0006
3.7	5	1750	184T	EHM3218T-8	15.3	15.3	20,34 (15)	89.1	89.9	89.5	63	74	79	6206	6205	200	419,10 (16.5)	CD0006
5.6	7 1/2	1770	213T	EHM3311T-8	22.2	22.2	30,10 (22.2)	90.4	91.2	91	63	74	80	6307	6206	200	414,53 (16.32)	CD0006
7.5	10	1770	215T	EHM3313T-8	29.5	29.5	40,27 (29.7)	91.7	92.2	91.7	62	74	80	6307	6206	200	443,23 (17.45)	CD0006
11	15	1765	254T	EHM2523T-8	40.7	40.7	60,47 (44.6)	93.3	93.5	93	70	81	86	6309	6208	200	550,93 (21.69)	CD0695
15	20	1765	256T	EHM2515T-8	54.3	54.3	79,99 (59)	92.1	93	93	65	75	85	6309	6208	200	550,93 (21.69)	CD0695
19	25	1770	284T	EHM2531T-8	69.5	69.5	100,47 (74.1)	93.4	94.2	93.6	69	79	83	6311	6309	200	604,77 (23.81)	CD0695
22	30	1770	286T	EHM2535T-8	81	81	120,53 (88.9)	93.6	94.2	94.1	72	82	85	6311	6309	200	636,52 (25.06)	CD0006
30	40	1775	324T	EHM2539T-8	108	108	159,99 (118)	93.6	92.4	94.1	76	85	84	6312	6311	200	677,93 (26.69)	CD0006
37	50	1775	326T	EHM2543T-8	132	132	200,66 (148)	93.4	94.2	94.5	69	79	87	6312	6311	200	703,33 (27.69)	CD0006

Notes: Volt code: E = 208-230/460V, 60 Hz; E1 = 230/460V, 60 Hz, usable at 208V; F = 230/460V, 60 Hz
 Contact your ABB regional support office for layout drawings. See pages 58 and 60 for connection diagrams.
 Efficiencies shown are nominal. Data subject to change without notice. Contact your ABB regional support office for certified data.

NEMA Super-E[®] premium efficient motors

HVAC motors – ODP with resilient base

These motors are used in heating, ventilation and air conditioning blower, and fan applications suitable for an open motor design.

Designed with heavy-gauge steel frame construction, ball bearings and resilient base mounting. The motors have dynamically balanced rotors for reduced vibration and quiet operation. All models meet NEMA Premium[®] efficiencies and have class F insulation with 1.15 service factor that operates within class “B” temperature limits at rated horsepower. Motors are protected with automatic thermal overloads and have 3-year warranty.



ODP – open drip proof, 208-230/460 volt, three phase, 2.2 – 3.7 kW (3 - 5 hp)

kW	Hp	RPM	Frame	Catalog number	Amps @ high V		F.L. torque Nm (lb-ft)	Efficiency %			Power factor %			Bearings		“C” dim. mm (in)	Conn. diag. no.
					Full load	Locked rotor		1/2	3/4	Full load	1/2	3/4	Full load	DE	ODE		
2,2	3	3450	56HZ	ERM3158TA	3.8	32.5	6,10 (4.5)	84.3	86	85.5	72	82	87	6205	6203	346,46 (13.64)	CD0005
3,7	5	3450	145TY	ERHM3162TA	6.1	60.4	10,37 (7.65)	88.5	88.4	86.5	76	85	89	6205	6203	381,51 (15.02)	CD0007

Notes: Contact your ABB regional support office for layout drawings. See page 57 for connection diagrams. Efficiencies shown are nominal. Data subject to change without notice. Contact your ABB regional support office for certified data.

Super-E[®] chiller/cooling tower motors

Chiller/Cooling Tower motors are for use in the airstream on chillers and cooling towers and are a direct replacement for most OEM applications. Designed for wet, high humidity environments they feature: corrosion resistant epoxy finish; double sealed bearings filled with moisture resistant grease; shaft seal/slinger; moisture resistant copper windings double dipped and baked; stainless steel nameplates and corrosion resistant hardware. “ECTM” model Super-E[®] motors meet NEMA Premium[®] efficiency, have class F insulation with 1.15 service factor and operate within class “B” temperature limits at rated horsepower.



TEAO - totally enclosed air over, foot mounted, 230/460 volts, three phase, 3.7 - 56 kW (5 - 75 hp)

kW	Hp	RPM	Frame	Catalog number	Amps @ high V		F.L. torque Nm (lb-ft)	Efficiency %			Power factor %			Bearings		Volt code	“C” dim. mm (in)	Conn. diag. no.	Airflow ft/min
					Full load	Locked rotor		1/2	3/4	Full load	1/2	3/4	Full load	DE	ODE				
3,7	5	1750	184T*	ECTM3665T	6.6	45.5	20,34 (15)	89.6	89.6	89.5	62	74	79	6206	6205	E	347,47 (13.68)	CD0005	1200
3,7	5	1160	215T*	ECTM3768T	7.3	51.9	30,91 (22.8)	90.1	90.8	90.2	54	65	72	6307	6206	E1	496,32 (19.54)	CD0005	1200
5,6	7 1/2	1770	213T*	ECTM3770T	9.5	68	29,96 (22.1)	91.1	91.9	91.7	65	76	81	6307	6206	E	496,32 (19.54)	CD0005	1500
5,6	7 1/2	1180	254T*	ECTM2276T	10.7	67	43,93 (32.4)	89.3	90.7	91	53	64	70	6309	6208	E1	527,05 (20.75)	CD0005	1500
7,5	10	1760	215T*	ECTM3774T	12.2	81	40,40 (29.8)	92.5	92.9	91.7	71	80	83	6307	6206	E	496,32 (19.54)	CD0005	1500
7,5	10	1180	256T*	ECTM2332T	14.4	95.1	60,20 (44.4)	89.9	91.3	91	55	65	71	6309	6208	E1	527,05 (20.75)	CD0180	1500
11	15	1765	254T*	ECTM2333T	18.5	122.9	60,47 (44.6)	91.9	92.6	92.4	66	77	82	6309	6208	E1	527,05 (20.75)	CD0005	1500
11	15	1180	284T*	ECTM4100T	20	118	89,08 (65.7)	90.6	92	91.7	58	69	75	6311	6309	F	651,00 (25.63)	CD0180	1500
15	20	1765	256T*	ECTM2334T	24	175	79,99 (59)	92.8	93.1	93	69	80	84	6309	6208	E1	527,05 (20.75)	CD0005	1500
15	20	1180	286T*	ECTM4102T	27	165	121,21 (89.4)	91.1	91.9	91.7	60	71	77	6311	6309	E1	651,00 (25.63)	CD0180	1500
19	25	1770	284T*	ECTM4103T	30	186	100,60 (74.2)	92.3	93.5	93.6	73	81	85	6311	6309	E1	651,00 (25.63)	CD0005	1500
19	25	1180	324T*	ECTM4111T	32	198	150,50 (111)	92.8	93.5	93	65	75	79	6312	6311	E1	720,85 (28.38)	CD0180	1500
22	30	1760	286T*	ECTM4104T	38	270	120,26 (88.7)	92.3	93.5	93.6	63	73	80	6311	6309	F	651,00 (25.63)	CD0180	1500
22	30	1180	326T*	ECTM4117T	39	243	180,32 (133)	92.5	93.2	93	62	73	78	6312	6311	E1	720,85 (28.38)	CD0005	1500
30	40	1775	324T*	ECTM4110T	48	338	159,99 (118)	93.5	94.2	94.1	69	78	82	6312	6311	E1	720,85 (28.38)	CD0180	1500
30	40	1190	364T*	ECTM4308T	49.4	290	239,98 (177)	93.6	94.3	94.1	69	77	81	6313	6313	E1	754,38 (29.7)	416820-2	2000
37	50	1775	326T*	ECTM4115T	57	392	202,02 (149)	94.4	94.9	94.5	73	82	85	6312	6311	E1	720,85 (28.38)	CD0180	2000
37	50	1185	365T*	ECTM4312T	61.7	345	299,64 (221)	93.9	94.4	94.1	70	78	81	6313	6313	E1	754,38 (29.7)	416820-2	2000
45	60	1780	364T*	ECTM4314T	68	447	239,98 (177)	94.7	95.2	95	74	82	86	6313	6313	E1	754,38 (29.7)	416820-2	2000
45	60	1185	404T*	ECTM4403T	69	455	359,29 (265)	94	94.7	95	69	78	83	6316	6316	F	880,87 (34.68)	416820-2	2000
56	75	1780	365T*	ECTM4316T	85.9	649	300,99 (222)	94.9	95.5	95.4	73	81	85	6313	6313	E1	754,38 (29.7)	416820-2	2000

Notes: Volt code: E = 208-230/460 Volts, E1 = 230/460 Volts, 60 Hz, usable at 208 Volts; F = 230/460V, 60 Hz

* Ratings are cast iron frames.

See page 53 for layout drawing. See pages 58 and 60 for connection diagrams.

Efficiencies shown are nominal. Data subject to change without notice. Contact your ABB regional support office for certified data.

NEMA Super-E[®] premium efficient motors

Super-E[®] premium efficient motors

Single phase – TEFC

Baldor•Reliance[®] Super-E[®] single phase motors provide energy savings on pump, fan, conveyor, machine tool, gear reducer and other applications where continuous operation is required. Rugged enclosure includes a heavy gauge steel frames and a heavy duty base seam welded to the frame, ball bearings and gasketed conduit box and capacitor cover. The Super-E electrical design is capacitor start/capacitor run and includes low loss electrical grade lamination steel, dynamically balanced rotors, a “snap action” starting switch and 1.15 service factor.



TEFC – totally enclosed fan cooled, foot mounted, 115/230 volts, single phase, 0.18– 3.7 kW (1/4 - 5 hp)

kW	Hp	RPM	Frame	Catalog number	Amps @ high V		F.L. torque Nm (lb-ft)	Efficiency %			Power factor %			Bearings		Volt code	“C” dim. mm (in)	Conn. diag. no.	Notes
					Full load	Locked rotor		1/2	3/4	Full load	1/2	3/4	Full load	DE	ODE				
0.18	1/4	1745	48	EL3403	1.25	9.1	1,02 (0.75)	62.6	70.8	74	73	79	89	6203	6203	B	288,29 (11.35)	CD0055	13
0.25	1/3	3450	48	EL3405	1.6	14.5	0,66 (0.49)	57.6	66.3	72	88	93	96	6203	6203	A	288,29 (11.35)	CD0055	13
0.25	1/3	1740	56	EL3501	1.6	11	1,36 (1)	68.6	75.5	77	80	83	88	6203	6203	B	304,04 (11.97)	CD0055	13
0.37	1/2	3450	56	EL3503	2.5	20	1,02 (0.75)	66.6	72.5	68	72	83	84	6203	6203	B	304,04 (11.97)	CD0055	12
0.37	1/2	1745	56	EL3504	2.3	18.1	2,03 (1.5)	72.4	76.5	78.5	79	87	89	6203	6203	B	304,04 (11.97)	CD0055	12
0.56	3/4	3450	56	EL3506	3.9	28.8	1,56 (1.15)	64.9	70.4	72	72	81	86	6203	6203	B	304,04 (11.97)	CD0055	12
0.56	3/4	1755	56	EL3507	3.15	30	3,05 (2.25)	79.8	83.8	82.5	78	85	90	6205	6203	A	336,55 (13.25)	CD0055	12
0.75	1	3450	56/56H	EL3509	4.7	38	2,03 (1.5)	63.9	70.8	74	91	94	94	6205	6203	A	328,42 (12.93)	CD0055	12
0.75	1	1760	56H	EL3510	4.25	40	4,07 (3)	77	83.2	82.5	84	87	91	6205	6203	B	350,77 (13.81)	CD0055	36
1,1	1 1/2	1760	56H	EL3514	6.3	51	6,10 (4.5)	84.4	86.2	84	85	92	94	6205	6203	B	385,57 (15.18)	CD0055	36
1,1	1 1/2	1760	145T	EL3514T	6.3	51	6,10 (4.5)	84.4	86.2	86.2	85	92	94	6205	6203	B	394,97 (15.55)	CD0055	-
1,5	2	3450	145T	EL3515T	8.3	58.5	4,05 (2.99)	72.7	77.8	77	97	98	96	6205	6203	A	360,17 (14.18)	CD0055	-
1,5	2	1740	182T	EL3605T	8.8	62.4	8,27 (6.1)	82.1	84	82.5	82	87	90	6206	6205	B	420,62 (16.56)	CD0055	-
2,2	3	3450	182T	EL3606T	12.4	83.7	6,39 (4.71)	81.2	82.8	82	99	99	98	6206	6205	B	420,62 (16.56)	CD0055	2
2,2	3	1755	184T	EL3609T	11.8	85	12,20 (9)	83.1	85.9	85.5	96	97	96	6206	6205	C	458,72 (18.06)	CD0017A02	-
3,7	5	3450	184T	EL3608T	19.4	145	10,20 (7.52)	85.4	86.6	85	99	99	98	6206	6205	C	458,72 (18.06)	CD0017A02	2
3,7	5	1735	182T	EL3612T	19.1	127	20,34 (15)	83.6	86.8	86.5	96	97	97	6206	6205	C	458,72 (18.06)	CD0017A02	2

Notes: Volt code: A = 115/208-230V, 60 Hz; B = 115/230V, 60 Hz; C = 230V, 60 Hz

2 = 1.00 service factor

12 = 1.25 service factor

13 = 1.35 service factor

36 = Can mount as NEMA 56, 143T & 145T frames with NEMA 56 frame shaft dimensions.

See page 57 for layout drawing. See page 59 for connection diagrams.

Efficiencies shown are nominal. Data subject to change without notice. Contact your ABB regional support office for certified data.

NEMA Super-E[®] premium efficient motors

Super-E[®] premium efficient motors

Single phase – ODP

Baldor•Reliance[®] Super-E[®] single phase motors provide energy savings on pump, fan, conveyor, machine tool, gear reducer and other applications where continuous operation is required. Rugged enclosure includes a heavy gauge steel frames and a heavy duty base seam welded to the frame and ball bearing construction. The Super-E electrical design is capacitor start/capacitor run and includes low loss electrical grade lamination steel, dynamically balanced rotors, a “snap action” starting switch and 1.15 service factor.



ODP – open drip proof, foot mounted, 115/230 volts, single phase, 0.18– 3.7 kW (1/4 - 5 hp)

kW	Hp	RPM	Frame	Catalog number	Amps @ high V		F.L. torque Nm (lb-ft)	Efficiency %			Power factor %			Bearings		Volt code	“C” dim. mm (in)	Conn. diag. no.	Notes
					Full load	Locked rotor		1/2	3/4	Full load	1/2	3/4	Full load	DE	ODE				
0,18	1/4	1745	48	EL1203	1.3	9.1	1,02 (0.75)	62.2	69.5	74	73	80	89	6203	6203	B	247,90 (9.76)	CD0055	13
0,25	1/3	3450	48	EL1205	1.6	14.5	0,66 (0.49)	57.6	66.3	72	88	93	96	6203	6203	A	247,90 (9.76)	CD0055	13
0,25	1/3	1740	56	EL1301	1.6	11	1,36 (1)	68.6	75.5	77	74	82	88	6203	6203	B	257,30 (10.13)	CD0055	13
0,37	1/2	3450	56	EL1303	2.5	19.95	1,02 (0.75)	66.6	72.5	68	72	83	84	6203	6203	B	257,30 (10.13)	CD0055	12
0,37	1/2	1745	56	EL1304	2.3	18.1	2,03 (1.5)	73.8	77.7	78.5	82	89	89	6203	6203	B	279,40 (11)	CD0055	12
0,56	3/4	3450	56	EL1306	3.9	28.75	1,56 (1.15)	64.9	70.4	72	72	81	86	6203	6203	B	279,40 (11)	CD0055	12
0,56	3/4	1755	56	EL1307	3.3	33.6	3,05 (2.25)	80.4	83.6	84	75	82	90	6205	6203	A	306,32 (12.06)	CD0055	12
0,75	1	3450	56	EL1309	5.1	42.75	2,03 (1.5)	70.1	74.9	74	65	77	82	6203	6203	A	279,40 (11)	CD0055	12
0,75	1	1755	56	EL1310	4.3	40.5	4,07 (3)	80.7	83.6	84	80	88	91	6205	6203	A	328,68 (12.94)	CD0055	-
1,1	1 1/2	3450	56H	EL1313	6.2	47	3,12 (2.3)	72.7	78.6	80	100	99	96	6203	6203	A	311,15 (12.25)	CD0055	36
1,1	1 1/2	1755	56H	EL1319	6.3	55	6,10 (4.5)	84.9	86.6	85.5	67	79	94	6205	6203	A	355,60 (14)	CD0055	36
1,1	1 1/2	1755	143T	EL1319T	6.3	55	6,10 (4.5)	84.9	86.6	85.5	67	79	94	6205	6203	A	330,20 (13)	CD0055	-
1,5	2	3450	56H	EL1317	9	60	4,07 (3)	72.9	79.7	75.5	93	95	93	6205	6203	B	298,45 (11.75)	CD0055	-
1,5	2	1740	182T	EL1405T	8.8	62.4	8,27 (6.1)	81.6	83.9	82.5	85	90	90	6206	6205	B	403,10 (15.87)	CD0055	-
2,2	3	3450	182T	EL1406T	12.3	78	6,18 (4.56)	77.6	81.1	81	98	98	98	6206	6205	B	381,00 (15)	CD0055	-
2,2	3	1750	184T	EL1408T	11.2	70.2	12,20 (9)	85	88	85.5	98	99	98	6206	6205	D	419,10 (16.5)	CD0017A02	-
3,7	5	3450	184T	EL1409T	20	114	10,02 (7.39)	79	82	81.5	98	98	97	6206	6205	C	381,00 (15)	CD0017A02	-
3,7	5	1735	184T	EL1410T	19.1	129	20,34 (15)	83	86.6	86.5	95	96	97	6206	6205	C	457,20 (18)	CD0017A02	-

Notes: Volt code: A = 115/208-230V, 60 Hz; B = 115/230V, 60 Hz; C = 230V, 60 Hz; D=208-230V, 60 Hz

12 = 1.25 service factor

13 = 1.35 service factor

36 = Can mount as NEMA 56, 143T & 145T frames with NEMA 56 frame shaft dimensions.

See page 57 for layout drawing. See page 59 for connection diagrams.

Efficiencies shown are nominal. Data subject to change without notice. Contact your ABB regional support office for certified data.

NEMA Super-E[®] premium efficient motors

Super-E[®] premium efficient 200 volt motors – TEFC

These motors are typically used on pumps, fans, compressors, blowers, machine tools, conveyors and many other applications requiring 200 volt power. Features include a rugged totally enclosed steel band or cast iron frame, positively locked drive end bearing on 254T and larger, ball bearings and dynamically balanced rotors. The Super-E[®] electrical design meets NEMA Premium[®] efficiency and has a 1.15 service factor. 3 year warranty.



TEFC – totally enclosed fan cooled, foot mounted, three phase, 0.75 - 37 kW (1 - 50 hp)

kW	Hp	RPM	Frame	Catalog number	Amps @ high V		F.L. torque Nm (lb-ft)	Efficiency %			Power factor %			Bearings		“C” dim. mm (in)	Conn. diag. no.	Notes
					F.L.	L.R.		1/2	3/4	F.L.	1/2	3/4	F.L.	DE	ODE			
0,75	1	1760	143T	EM3546T-8	3.5	27.4	4,07 (3)	82.3	84.6	85.5	50	62	71	6205	6203	312,67 (12.31)	CD0006	68
1,1	1 1/2	1760	145T	EM3554T-8	5	42.2	6,10 (4.5)	85.1	87.5	86.5	51	65	74	6205	6203	338,07 (13.31)	CD0006	68
1,5	2	1750	145T	EM3558T-8	6.8	55.5	8,13 (6)	83.9	86.4	86.5	51	64	73	6205	6203	360,43 (14.19)	CD0006	68
2,2	3	3460	182T*	EM3660T-8	8.8	72.2	6,37 (4.7)	85.9	87.3	86.5	75	84	88	6206	6205	387,10 (15.24)	CD0006	68
2,2	3	1755	182T*	EM3661T-8	9.5	68.9	12,20 (9)	88.3	89.7	89.5	58	70	77	6206	6205	387,10 (15.24)	CD0006	68
3,7	5	3475	184T*	EM3663T-8	14.5	120	10,17 (7.5)	87.8	89.1	88.5	63	76	83	6206	6205	387,10 (15.24)	CD0006	68
3,7	5	1750	184T*	EM3665T-8	15.1	103	20,34 (15)	90.5	90.3	89.5	63	74	80	6206	6205	387,10 (15.24)	CD0006	68
5,6	7 1/2	3525	213T*	EM3769T-8	19.8	173	15,19 (11.2)	90	91.4	91	79	87	90	6307	6206	468,63 (18.45)	CD0006	68
5,6	7 1/2	1770	213T*	EM3770T-8	21.4	148	29,96 (22.1)	91.5	92.1	91.7	68	78	82	6307	6206	468,63 (18.45)	CD0006	68
7,5	10	3500	215T*	EM3771T-8	26.8	192	20,20 (14.9)	92.9	93.1	90.2	80	89	91	6307	6206	468,63 (18.45)	CD0006	68
7,5	10	1760	215T*	EM3774T-8	28	186	40,40 (29.8)	92.6	93.1	91.7	71	80	83	6307	6206	468,63 (18.45)	CD0006	68
11	15	3525	254T*	EM2394T-8	40	262	30,10 (22.2)	90.6	91.4	91	79	86	89	6309	6208	588,26 (23.16)	CD0006	68
11	15	1765	254T*	EM2333T-8	42.4	282	60,47 (44.6)	91.9	92.6	92.4	66	76	82	6309	6208	588,26 (23.16)	CD0006	30,68
15	20	3510	256T*	EM4106T-8	52	347	40,54 (29.9)	92.1	92.1	91	80	87	90	6309	6208	588,26 (23.16)	CD0006	24,69
15	20	1765	256T*	EM2334T-8	55.2	402	79,99 (59)	92.8	93.1	93	69	80	84	6309	6208	588,26 (23.16)	CD0695	24,30,69
19	25	3520	284TS*	EM4107T-8	65	442	50,57 (37.3)	92.9	92.8	91.7	81	87	90	6311	6208	652,78 (25.7)	CD0006	24,69
19	25	1770	284T*	EM4103T-8	68.4	431	100,60 (74.2)	92.4	93.6	93.6	72	81	84	6311	6309	705,10 (27.76)	CD0695	24,69
22	30	3520	286TS*	EM4108T-8	76	600	60,61 (44.7)	93.2	93	91.7	80	87	91	6311	6208	627,38 (24.7)	CD0695	24,69
22	30	1770	286T*	EM4104T-8	84	560	120,67 (89)	93.5	94.3	93.6	64	73	82	6311	6309	705,10 (27.76)	CD0006	24,69
30	40	1775	324T*	EM4110T-8	111	758	159,99 (118)	93.6	94.4	94.1	68	77	82	6312	6311	769,11 (30.28)	CD0006	24,69
37	50	1775	326T*	EM4115T-8	131	897	202,02 (149)	94.4	94.9	94.5	71	81	88	6312	6311	769,11 (30.28)	CD0695	24,69

Notes: 24 = Part winding start or DOL

30 = Usable at 208 volts

68 = 3 lead design

69 = 6 lead suitable for part winding start on 200 volts.

* Ratings are cast iron frames.

See pages 40 and 41 for layout drawings. See pages 58 and 60 for connection diagrams.

Efficiencies shown are nominal. Data subject to change without notice. Contact your ABB regional support office for certified data.

NEMA Super-E[®] premium efficient motors

Super-E[®] premium efficient

200 volt motors – ODP

These motors are typically used on pumps, fans, compressors, blowers, machine tools, conveyors and many other applications requiring 200 volt power. Features include a rugged open design steel band or cast iron frame, positively locked drive end bearing on 254T and larger, ball bearings and dynamically balanced rotors. The Super-E[®] electrical design meets NEMA Premium[®] efficiency and has a 1.15 service factor. 3 year warranty.

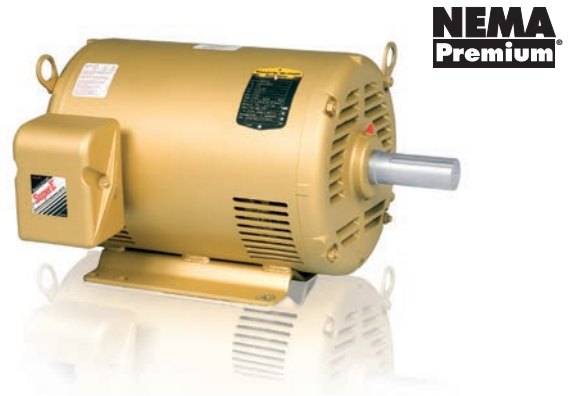

ODP – open drip proof, foot mounted, three phase, 0.75 - 75 kW (1 - 100 hp)

kW	Hp	RPM	Frame	Catalog number	Amps @ high V		F.L. torque Nm (lb-ft)	Efficiency %			Power factor %			Bearings		“C” dim. mm (in)	Conn. diag. no.	Notes
					F.L.	L.R.		1/2	3/4	F.L.	1/2	3/4	F.L.	DE	ODE			
F1 mounting																		
0.75	1	1760	143T	EM3116T-8	3.5	27.4	4,07 (3)	82.3	84.6	85.5	50	62	71	6205	6203	282,45 (11.12)	CD0006	68
1,1	1 1/2	1755	145T	EM3154T-8	5.1	39.6	6,10 (4.5)	83.1	85.9	86.5	51	64	73	6205	6203	295,15 (11.62)	CD0006	68
1,5	2	1750	145T	EM3157T-8	6.5	49.1	8,13 (6)	84.5	86.5	86.5	56	69	77	6205	6203	307,85 (12.12)	CD0006	68
2,2	3	1765	182T	EM3211T-8	9.7	75.1	12,07 (8.9)	87.4	89.4	89.5	53	66	73	6206	6205	381,00 (15)	CD0006	68
3,7	5	1750	184T	EM3218T-8	15.3	105	20,34 (15)	89.1	89.9	89.5	63	74	79	6206	6205	419,10 (16.5)	CD0006	68
5,6	7 1/2	1770	213T	EM3311T-8	22.2	154	30,10 (22.2)	90.5	91.3	91	63	74	80	6307	6206	414,53 (16.32)	CD0006	68
7,5	10	1770	215T	EM3313T-8	29.5	215	40,27 (29.7)	91.7	92.2	91.7	62	74	80	6307	6206	443,23 (17.45)	CD0006	68
11	15	1765	254T	EM2513T-8	40.7	271	60,47 (44.6)	93.3	93.5	93	70	81	86	6309	6208	550,93 (21.69)	CD0006	68
15	20	3510	254T	EM2514T-8	52.3	336	40,54 (29.9)	93.5	93.3	91	72	81	89	6309	6208	550,93 (21.69)	CD0695	24,69
15	20	1765	256T	EM2515T-8	54.3	373	79,99 (59)	92.1	93	93	65	75	85	6309	6208	550,93 (21.69)	CD0695	24,69
19	25	3520	256T	EM2516T-8	63.2	475	50,17 (37)	91.3	92.8	91.7	78	85	91	6309	6208	550,93 (21.69)	CD0695	24,69
19	25	1770	284T	EM2531T-8	69.5	438	100,47 (74.1)	93.4	94.2	93.6	69	79	83	6311	6309	604,77 (23.81)	CD0695	24,69
22	30	1770	286T	EM2535T-8	81	514	120,53 (88.9)	93.6	94.2	94.1	72	82	85	6311	6309	636,52 (25.06)	CD0695	24,69
30	40	3540	286TS	EM2538T-8	105	825	81,08 (59.8)	94.4	94.7	92.4	79	85	88	6311	6309	601,73 (23.69)	CD0695	24,69
30	40	1775	324T	EM2539T-8	107	730	159,99 (118)	93.1	94.2	94.1	67	78	85	6312	6311	677,93 (26.69)	CD0695	24,69
37	50	1775	326T	EM2543T-8	132	877	200,66 (148)	93.6	94.4	94.5	70	80	87	6312	6311	703,33 (27.69)	CD0695	24,69
45	60	1775	364T	EM2547T-8	160	1080	239,98 (177)	94.9	95.3	95	77	85	87	6313	6311	779,53 (30.69)	CD0695	24,69
56	75	1780	365T*	EM2551T-8	199	1175	300,99 (222)	95.4	95.7	95	76	83	86	6313	6313	754,38 (29.7)	416820-15	24,69
75	100	1780	404T	EM2555T-8	263	1745	399,97 (295)	95.4	95.8	95.4	69	79	86	6316	6312	939,04 (36.97)	CD0695	24,69
F2 mounting																		
1,5	2	1750	145T	EFM3157T-8	6.5	49.1	8,13 (6)	84.5	86.5	86.5	56	69	77	6205	6203	307,85 (12.12)	CD0006	68
2,2	3	1765	182T	EFM3211T-8	9.7	75.1	12,07 (8.9)	87.4	89.4	89.5	53	66	73	6206	6205	381,00 (15)	CD0006	68
3,7	5	1750	184T	EFM3218T-8	15.3	105	20,34 (15)	89.1	89.9	89.5	63	74	79	6206	6205	419,10 (16.5)	CD0006	68
5,6	7 1/2	1770	213T	EFM3311T-8	22.3	157	29,96 (22.1)	89.6	91.3	91	62	73	79	6307	6206	414,53 (16.32)	CD0006	68
7,5	10	1770	215T	EFM3313T-8	29.5	215	40,27 (29.7)	91.7	92.2	91.7	62	74	80	6307	6206	443,23 (17.45)	CD0006	68
11	15	1765	254T	EFM2513T-8	40.7	271	60,47 (44.6)	93.3	93.5	93	70	81	86	6309	6208	550,93 (21.69)	CD0006	68
15	20	1765	256T	EFM2515T-8	54.3	373	79,99 (59)	92.1	93	93	65	75	85	6309	6208	550,93 (21.69)	CD0695	24,69

Notes: 24 = Part winding start or DOL

68 = 3 lead design

69 = 6 lead suitable for part winding start on 200 volts.

* Ratings are cast iron frames.

See pages 45 and 46 for layout drawings. See pages 58 through 61 for connection diagrams.

Efficiencies shown are nominal. Data subject to change without notice. Contact your ABB regional support office for certified data.

NEMA Super-E[®] premium efficient motors

Unit handling motors

These Baldor•Reliance[®] motors are designed and manufactured for use in unit and baggage handling, conveyors, packaging equipment, machine tools, hoists, elevators and door operators.

Motors are a Super-E[®] design with NEMA Premium[®] efficiency, Class F insulation, 1.15 service factor and are Inverter Ready. 143-145TY and 143-145TCY frame motors have a special base with 56, 143 and 145 slots used on OEM conveyors. 56-140 frames have low profile F3 top-mounted conduit box. 3 year warranty on Super-E[®] motors. UL/CSA recognized and CE certified.



TEFC – totally enclosed fan cooled, 208-230/460 & 575 volt, three phase, 0.37 – 5.6 kW (1/2 – 7.5 hp)

kW	Hp	RPM	Frame	Catalog number	Amps @ high V			Efficiency %			Power factor %			Bearings		“C” dim. mm (in)	Conn. diag. no.
					F.L.	L.R.	F.L. torque Nm (lb-ft)	1/2	3/4	F.L.	1/2	3/4	F.L.	DE	ODE		
C-face foot mounted - 208-230/460 volt																	
0,75	1	1760	143TCY	CEUHM3546T	1.5	12.1	4,07 (3)	82.1	84.8	85.5	49	62	71	6205	6203	337,57 (13.29)	CD0005
1,1	1 1/2	1760	145TYC	CEUHM3554T	2.2	18.3	6,10 (4.5)	84.5	86.8	86.5	51	65	73	6205	6203	337,57 (13.29)	CD0005
1,5	2	1755	145TCY	CEUHM3558T	2.9	24.3	8,13 (6)	84.2	86.4	86.5	51	64	73	6205	6203	359,92 (14.17)	CD0005
2,2	3	1760	182TC	CEUHM3611T	4.2	32	12,07 (8.9)	87.8	89.5	89.5	54	68	75	6206	6205	420,37 (16.55)	CD0005
3,7	5	1750	184TC	CEUHM3615T	6.7	49.1	20,20 (14.9)	89.7	90.3	89.5	60	72	78	6206	6205	458,47 (18.05)	CD0005
C-face footless - 208-230/460 volt																	
0,37	1/2	1735	56C	VEUHM3538	0.8	5.6	2,03 (1.5)	80.3	82.5	82.5	52	65	74	6205	6203	336,04 (13.23)	CD0005
0,37	1/2	1750	56C	VEUHM3542	1.1	9.7	2,98 (2.2)	80.3	83.8	84	49	63	72	6205	6203	336,04 (13.23)	CD0005
0,75	1	1760	56C	VEUHM3546	1.5	12.1	4,07 (3)	82.1	84.8	85.5	49	62	71	6205	6203	336,04 (13.23)	CD0005
0,75	1	1760	143TC	VEUHM3546T	1.5	12.1	4,07 (3)	82.1	84.8	85.5	49	62	71	6205	6203	337,57 (13.29)	CD0005
1,1	1 1/2	1760	145TC	VEUHM3554T	2.2	18.3	6,10 (4.5)	84.5	86.8	86.5	51	65	73	6205	6203	337,57 (13.29)	CD0005
1,5	2	1755	145TC	VEUHM3558T	2.9	24.3	8,13 (6)	84.2	86.4	86.5	51	64	73	6205	6203	359,92 (14.17)	CD0005
2,2	3	1760	182TC	VEUHM3611T	4.2	32	12,07 (8.9)	87.8	89.5	89.5	54	68	75	6206	6205	420,37 (16.55)	CD0005
3,7	5	1750	184TC	VEUHM3615T	6.7	49.1	20,20 (14.9)	89.7	90.3	89.5	60	72	78	6206	6205	458,47 (18.05)	CD0005
5,6	7 1/2	1770	213TC	VEUHM3710T	9.4	71.6	30,23 (22.3)	91.8	92.4	91.7	62	75	81	6307	6206	501,90 (19.76)	CD0005
C-face footless - 575 volt																	
0,75	1	1760	143TC	VEUHM3546T-5	1.2	9.7	4,07 (3)	81.9	84.8	85.5	49	62	71	6205	6203	337,57 (13.29)	CD0006
1,1	1 1/2	1760	145TC	VEUHM3554T-5	1.8	14.6	6,10 (4.5)	84.5	87	86.5	51	65	74	6205	6203	337,57 (13.29)	CD0006
1,5	2	1755	145TC	VEUHM3558T-5	2.4	19.6	8,13 (6)	83.8	86.4	86.5	50	64	73	6205	6203	359,92 (14.17)	CD0006

Notes: See page 54 and 55 for layout drawing. See page 58 for connection diagrams.

Efficiencies shown are nominal. Data subject to change without notice. Contact your ABB regional support office for certified data.

NEMA Super-E[®] premium efficient motors

Unit handling motors

D-series brake motors

These Baldor•Reliance[®] motors are designed and manufactured for use in unit and baggage handling, conveyors, packaging equipment, machine tools, hoists, elevators and door operators.

Motors are a Super-E[®] design with NEMA Premium[®] efficiency, class F insulation, 1.15 service factor and are inverter ready. Dodge “D” series brakes are spring set, magnetically released power off type brakes flange mounted to the motor. Brakes are single phase with built-in rectifier to DC. Brakes have a manual release lever. Leads are brought to the motor conduit box for connecting to the motor leads (56-140 frames) or connecting separately (180-210 frames). 56-140 frames have low profile F3 top-mounted conduit box. D series brake motors can be universally mounted. Inverter ready. 143-145TY and 143-145TCY frame motors have a special base with 56, 143 and 145 slots used on OEM conveyors. UL/CSA recognized and CE certified.



TEFC – totally enclosed fan cooled, 208-230/460 & 575 volt, three phase, 0.75 – 7.5 kW (1 – 10 hp)

kW	Hp	RPM	Frame	Catalog number	Amps @ high V		F.L. torque Nm (lb-ft)	Efficiency %			Power factor %			Bearings		“C” dim. mm (in)	Conn. diag. no.	Brake rating Nm ² (lb-ft ²)	
					F.L.	L.R.		1/2	3/4	F.L.	1/2	3/4	F.L.	DE	ODE				
Foot mounted - 208-230/460 volt																			
1,5	2	1750	145TY	EBM3558T-D	2.9	23.7	8,13 (6)	85.4	86.9	86.5	53	67	75	6205	6205	440,69 (17.35)	CD0005	478,8 (10)	
2,2	3	1760	182T	EBM3611T-D	4.1	32	12,20 (9)	89.1	90	89.5	58	73	77	6206	6205	549,66 (21.64)	CD0005	718,2 (15)	
3,7	5	1750	184T	EBM3615T-D	6.7	49.1	20,20 (14.9)	89.7	90.3	89.5	60	72	78	6206	6205	587,76 (23.14)	CD0005	1197,0 (25)	
5,6	7 1/2	1770	213T	EBM3710T-D	9.4	71.6	30,23 (22.3)	91.8	92.4	91.7	62	75	81	6307	6206	645,67 (25.42)	CD0005	1197,0 (25)	
7,5	10	1770	215T	EBM3714T-D	12	103	40,00 (29.5)	92.1	92.4	91.7	66	79	85	6307	6206	683,77 (26.92)	CD0005	2394,0 (50)	
C-face foot mounted - 208-230/460 volt																			
1,5	2	1750	145TCY	CEBM3558T-D	2.9	23.7	8,13 (6)	85.4	86.9	86.5	53	67	75	6205	6205	440,69 (17.35)	CD0005	478,8 (10)	
2,2	3	1760	182TC	CEBM3611T-D	4.1	32	12,20 (9)	89.1	90	89.5	58	73	77	6206	6205	549,66 (21.64)	CD0005	718,2 (15)	
3,7	5	1750	184TC	CEBM3615T-D	6.7	49.1	20,20 (14.9)	89.7	90.3	89.5	60	72	78	6206	6205	587,76 (23.14)	CD0005	1197,0 (25)	
5,6	7 1/2	1770	213TC	CEBM3710T-D	9.4	71.6	30,23 (22.3)	91.8	92.4	91.7	62	75	81	6307	6206	664,72 (26.17)	CD0005	1197,0 (25)	
7,5	10	1770	215TC	CEBM3714T-D	12	103	40,00 (29.5)	92.1	92.4	91.7	66	79	85	6307	6206	702,82 (27.67)	CD0005	1675,8 (35)	
C-face footless - 208-230/460 volt																			
0,75	1	1760	56C	VEBM3546-D	1.5	12.1	4,07 (3)	82.1	84.8	85.5	49	62	71	6205	6205	413,77 (16.29)	CD0005	287,3 (6)	
0,75	1	1760	143TC	VEBM3546T-D	1.5	12.1	4,07 (3)	82.1	84.8	85.5	49	62	71	6205	6205	415,29 (16.35)	CD0005	287,3 (6)	
1,1	1 1/2	1760	56C	VEBM3554-D	2.2	18.3	6,10 (4.5)	84.5	86.8	86.5	51	65	73	6205	6205	439,17 (17.29)	CD0005	478,8 (10)	
1,1	1 1/2	1760	145TC	VEBM3554T-D	2.2	18.3	6,10 (4.5)	84.5	86.8	86.5	51	65	73	6205	6205	440,69 (17.35)	CD0005	478,8 (10)	
1,5	2	1755	145TC	VEBM3558T-D	2.9	24.3	8,13 (6)	84.2	86.4	86.5	51	64	73	6205	6205	463,04 (18.23)	CD0005	478,8 (10)	
2,2	3	1760	182TC	VEBM3611T-D	4.2	32	12,07 (8.9)	87.8	89.5	89.5	54	68	75	6206	6205	549,66 (21.64)	CD0005	718,2 (15)	
3,7	5	1750	184TC	VEBM3615T-D	6.7	49.1	20,20 (14.9)	89.7	90.3	89.5	60	72	78	6206	6205	587,76 (23.14)	CD0005	718,2 (15)	
5,6	7 1/2	1770	213TC	VEBM3710T-D	9.4	71.6	30,23 (22.3)	91.8	92.4	91.7	62	75	81	6307	6206	664,72 (26.17)	CD0005	1197,0 (25)	
C-face footless - 575 volt																			
0,75	1	1760	143TC	VEBM3546T-5D	1.2	9.66	4,07 (3)	81.9	84.8	85.5	49	62	71	6205	6205	415,29 (16.35)	CD0006	287,3 (6)	
1,5	2	1755	184TC	VEBM3558T-5D	2.4	19.6	8,13 (6)	83.8	86.4	86.5	50	64	73	6205	6205	463,04 (18.23)	CD0006	478,8 (10)	
2,2	3	1760	182TC	VEBM3611T-5D	3.1	25.6	12,20 (9)	89.1	90	89.5	58	71	77	6206	6205	549,66 (21.64)	CD0006	718,2 (15)	
3,7	5	1750	184TC	VEBM3615T-5D	5.2	38	20,34 (15)	89.8	90.5	89.5	61	73	81	6206	6205	587,76 (23.14)	CD0006	718,2 (15)	
1,1	1 1/2	1760	145TC	VEBM3554T-5D	1.8	14.6	6,10 (4.5)	84.5	87	86.5	51	65	74	6205	6205	440,69 (17.35)	CD0006	478,8 (10)	

Notes: Contact your ABB regional support office for layout drawings. See page 58 for connection diagrams. Efficiencies shown are nominal. Data subject to change without notice. Contact your ABB regional support office for certified data.

NEMA Super-E[®] premium efficient motors

Super-E[®] brake motors – TEFC

Baldor•Reliance[®] Super-E[®] brake motors are designed and built for industrial machine tools, conveyors, door operators, speed reducers, any application requiring quick stops and positive hold.

Available in TEFC and ODP enclosures, they feature spring-set brakes with a power off manual release that resets automatically. Class F insulated with 1.15 service factor. Motors have NEMA Premium[®] efficiency and are suitable for inverter use. 230/460V brakes are connected in conduit box allowing for separate connection when used with an inverter.

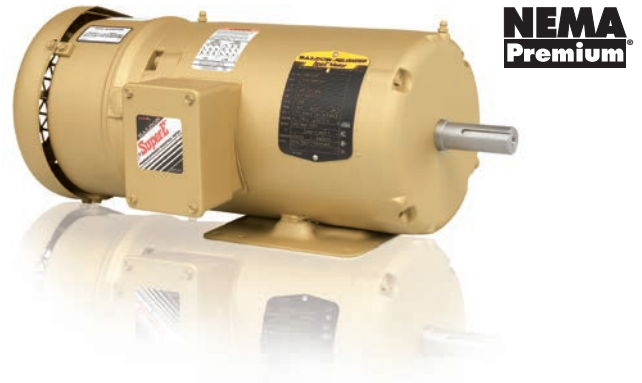

TEFC – totally enclosed fan cooled, 230/460 volts, three phase, 0.37 – 22 kW (1/2 - 30 hp)

kW	Hp	RPM	Frame	Catalog number	Amps @ high V		F.L. torque Nm (lb-ft)	Efficiency %			Power factor %			Bearings		Volt code	"C" dim. mm (in)	Conn. diag. no.	Brake rating Nm ² (lb-ft ²)	Notes
					Full load	Locked rotor		1/2	3/4	Full load	1/2	3/4	Full load	DE	ODE					
Foot mounted																				
0,75	1	1760	56	EBM3546	1.5	12.1	4,07 (3)	82.1	84.8	85.5	49	62	71	6205	6203	E	426,72 (16.8)	CD0005	287,3 (6)	41
0,75	1	1760	143T	EBM3546T	1.5	12.1	4,07 (3)	82.1	84.8	85.5	49	62	71	6205	6203	E	453,64 (17.86)	CD0005	287,3 (6)	41
1,1	1 1/2	1760	145T	EBM3554T	2.2	18.3	6,10 (4.5)	84.5	86.8	86.5	51	65	73	6205	6203	E	453,64 (17.86)	CD0005	478,8 (10)	41
1,5	2	1755	145T	EBM3558T	2.9	24.3	8,13 (6)	84.2	86.4	86.5	51	64	73	6205	6203	E	476,00 (18.74)	CD0005	478,8 (10)	41
2,2	3	1760	182T	EBM3611T	4.2	32	12,07 (8.9)	87.8	89.5	89.5	54	68	75	6206	6205	E	536,45 (21.12)	CD0005	718,2 (15)	41
3,7	5	1750	184T	EBM3615T	6.7	49.1	20,20 (14.9)	89.7	90.3	89.5	60	72	78	6206	6205	E	575,31 (22.65)	CD0005	1197,0 (25)	40
5,6	7 1/2	1770	213T	EBM3710T	9.4	70.1	30,37 (22.4)	92.2	92.7	91.7	63	75	81	6307	6306	E1	690,88 (27.2)	CD0005	1675,8 (35)	40
7,5	10	1770	215T	EBM3714T	12	103	40,00 (29.5)	92.1	92.4	91.7	66	79	85	6307	6306	E	741,43 (29.19)	CD0005	2394,0 (50)	40
11	15	1765	254T*	EBM2333T	18.5	122.9	60,47 (44.6)	91.9	92.6	92.4	66	77	82	6309	6208	E1	839,98 (33.07)	CD0005	3591,0 (75)	-
15	20	1765	256T*	EBM2334T	24	175	79,99 (59)	92.8	93.1	93	69	80	84	6309	6208	E1	852,68 (33.57)	CD0005	5027,4 (105)	-
19	25	1770	284T*	EBM4103T	30	186	100,60 (74.2)	92.3	93.5	93.6	73	81	85	6311	6309	E1	1007,36 (39.66)	CD0005	5027,4 (105)	-
22	30	1780	284T*	EBM4104T	37	216	122,02 (90)	93.5	94.1	93.6	67	78	82	6311	6309	E1	1088,14 (42.84)	CD0005	5985,0 (125)	-
C-face footless																				
0,37	1/2	1765	56C	VEBNM3538	0.9	7.5	2,03 (1.5)	77.9	81.9	84	41	54	64	6205	6203	F	387,60 (15.26)	CD0005	143,6 (3)	41,60
0,56	3/4	1750	56C	VEBNM3542	1.1	9.7	2,98 (2.2)	80.3	83.8	84	49	63	72	6205	6203	E	387,60 (15.26)	CD0005	287,3 (6)	41,60
0,75	1	1760	56C	VEBM3546	1.5	12.1	4,07 (3)	82.1	84.8	85.5	49	62	71	6205	6203	E	426,72 (16.8)	CD0005	287,3 (6)	41
0,75	1	1760	143TC	VEBM3546T	1.5	12.1	4,07 (3)	82.1	84.8	85.5	49	62	71	6205	6203	E	453,64 (17.86)	CD0005	287,3 (6)	41
1,1	1 1/2	1760	56C	VEBM3554	2.2	18.3	6,10 (4.5)	84.5	86.8	86.5	51	65	73	6205	6203	E	452,12 (17.8)	CD0005	287,3 (6)	41
1,1	1 1/2	1760	145TC	VEBM3554T	2.2	18.3	6,10 (4.5)	84.5	86.8	86.5	51	65	73	6205	6203	E	453,64 (17.86)	CD0005	478,8 (10)	41
1.5	2	1755	56C	VEBM3558	2.9	24.3	8,13 (6)	84.2	86.4	86.5	51	64	73	6205	6203	E	474,22 (18.67)	CD0005	287,3 (6)	41
1.5	2	1755	145TC	VEBM3558T	2.9	24.3	8,13 (6)	84.2	86.4	86.5	51	64	73	6205	6203	E	476,00 (18.74)	CD0005	478,8 (10)	41
2,2	3	1760	182TC	VEBM3611T	4.2	32	12,07 (8.9)	87.8	89.5	89.5	54	68	75	6206	6205	E	536,19 (21.11)	CD0005	718,2 (15)	41
3,7	5	1750	184TC	VEBM3615T	6.7	49.1	20,20 (14.9)	89.7	90.3	89.5	60	72	78	6206	6205	E	585,72 (23.06)	CD0005	1197,0 (25)	40
5,6	7 1/2	1770	213TC	VEBM3710T	9.4	70.1	30,37 (22.4)	92.2	92.7	91.7	63	75	81	6307	6306	E1	709,93 (27.95)	CD0005	1675,8 (35)	40
7,5	10	1770	215TC	VEBM3714T	12	103	40,00 (29.5)	92.1	92.4	91.7	66	79	85	6307	6306	E	760,73 (29.95)	CD0005	2394,0 (50)	40

Notes: Volt code: E = 208-230/460V, 60 Hz; E1 = 230/460V, 60 Hz, usable at 208V, F=230/460V, 60 Hz

40 = Brakes may be mounted for vertical mounting with brake below the motor.

41 = Brakes may be mounted for vertical mounting with brake above or below the motor.

60 = TENV - totally enclosed non-ventilated enclosure

* Ratings are cast iron frames.

See page 47 for layout drawings. See page 58 for connection diagram.

Efficiencies shown are nominal. Data subject to change without notice. Contact your ABB regional support office for certified data.

NEMA Super-E[®] premium efficient motors

Super-E[®] brake motors – ODP

Baldor•Reliance[®] Super-E[®] brake motors are designed and built for industrial machine tools, conveyors, door operators, speed reducers, any application requiring quick stops and positive hold.

Available in TEFC and ODP enclosures, they feature spring-set brakes with a power off manual release that resets automatically. Class F insulated with 1.15 service factor. Motors have NEMA Premium[®] efficiency and are suitable for inverter use. 230/460V brakes are connected in conduit box allowing for separate connection when used with an inverter.

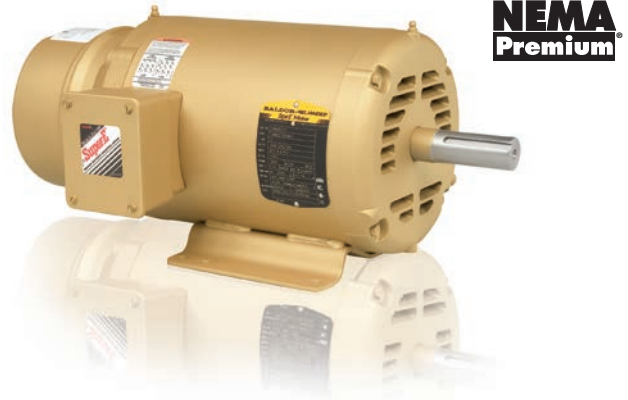

ODP – open drip proof, foot mounted, three phase, 0.75 – 11 kW (1 - 15 hp)

kW	Hp	RPM	Frame	Catalog number	Amps @ high V		F.L. torque Nm (lb-ft)	Efficiency %			Power factor %			Bearings		Volt code	"C" dim. mm (in)	Conn. diag. no.	Brake rating Nm ² (lb-ft ²)	Notes
					Full load	Locked rotor		1/2	3/4	Full load	1/2	3/4	Full load	DE	ODE					
0,75	1	1765	143T	EBM3116T	1.5	15	4,07 (3)	83.6	86.7	87.5	48	60	70	6205	6203	E	415,80 (16.37)	CD0005	287,3 (6)	41
1,1	1 1/2	1755	145T	EBM3154T	2.2	17.5	6,10 (4.5)	83.5	86	86.5	50	63	72	6205	6203	E1	415,80 (16.37)	CD0005	478,8 (10)	41
1,5	2	1750	145T	EBM3157T	2.9	24.3	8,13 (6)	84.4	86.6	86.5	51	64	73	6205	6203	E1	415,80 (16.37)	CD0005	478,8 (10)	41
2,2	3	1765	182T	EBM3211T	4.2	32.3	12,07 (8.9)	87.6	89.6	89.5	53	66	73	6206	6205	E	497,08 (19.57)	CD0005	718,2 (15)	41
3,7	5	1750	184T	EBM3218T	6.4	48	20,34 (15)	89.8	90.5	89.5	61	73	81	6206	6205	E	546,61 (21.52)	CD0005	1197,0 (25)	40
3,7	5	1750	184T	EBM3248T	6.4	48	20,34 (15)	89.8	90.5	89.5	61	73	81	6206	6205	E	534,92 (21.06)	CD0005	718,2 (15)	41
5,6	7 1/2	1770	213T	EBM3311T	9.7	68.2	29,96 (22.1)	90.5	91.4	91	62	73	79	6307	6306	E	621,03 (24.45)	CD0005	1675,8 (35)	40
7,5	10	1770	215T	EBM3313T	12.5	88.3	40,27 (29.7)	91.6	92.3	91.7	66	77	82	6307	6306	E	662,43 (26.08)	CD0005	2394,0 (50)	40
11	15	1765	254T	EBM2513T	17.7	211	60,74 (44.8)	93.7	93.7	93	82	88	90	6309	6309	E	758,95 (29.88)	CD0180	3591,0 (75)	40

Notes: Brakes are internally connected on 215T and smaller. Brake should be separately connected when motor is used with any electronic soft start or adjustable speed drive.

Volt code: E = 208-230/460V, 60 Hz; E1 = 230/460V, 60 Hz, usable at 208V

40 = Brakes may be mounted for vertical mounting with brake below the motor.

41 = Brakes may be mounted for vertical mounting with brake above or below the motor.

Contact your ABB regional support office for layout drawings. See page 58 and 60 for connection diagram.

Efficiencies shown are nominal. Data subject to change without notice. Contact your ABB regional support office for certified data.

NEMA Super-E[®] premium efficient motors

Adjustable speed capabilities for even greater energy efficiency

Super-E[®] Motors

Super-E motors are inverter-ready and meet NEMA MG 1 Part 31.4.4.2. Super-E motors are suitable for use with inverter drives. Motor inverter setup is unique to each specific application. Proper setup and wiring procedures must be closely followed.

Application Considerations

It is necessary that motor-drive applications are commissioned by persons familiar with the operation and setup of adjustable speed drives, applicable electrical codes and any other regulations.

Each drive must be tuned to the motor for the specific application. System operating parameters must be checked, including voltage at motor power leads, to insure that motor/drive setup has been successfully completed.

Applications that are not properly setup can lead to substandard performance and failure of system components.

In some installations, shaft grounding and isolated bearings may prevent bearing fluting and are available as an option or through Mod Express.

Reference the chart below for constant torque and variable torque capabilities for each product family. Torque performance depends upon proper drive setup.

Motors 48 body style and smaller are suitable for maximum 230V inverter operation.

Efficiency Savings

Significant energy savings can be achieved when applying inverter ready motors such as the Baldor•Reliance[®] Super-E to centrifugal load applications (fan and centrifugal pump) and running at reduced speed taking advantage of the affinity laws where motor load and corresponding energy consumption is reduced by the cube of the speed.



Family	Enclosure	Frame size	Constant torque	Variable torque	Comments
Super-E[®] motors 230, 460 and 575 volts (2)					
EM	TEFC	56-210 (1)	20:1	20:1	General purpose premium efficient
		250-320	10:1	20:1	
		360-400	4:1	20:1	
		444-449	2:1	20:1	
EM	ODP	56-210 (1)	10:1	20:1	General purpose premium efficient
		250-320	5:1	20:1	
		360 - 449	2:1	20:1	
ECTM	TEAO	140	20:1	20:1	Severe duty premium efficient
		180-210	10:1	20:1	
		250-400	4:1	20:1	
		444-449	2:1	20:1	

Notes:

(1) your regional support office type 35M frames and larger

(2) For greater speed range capabilities, please select an Inverter Duty[®], Vector Duty[®], V*S Master or RPM AC type motor, or contact your ABB regional support office for a custom motor design.

NEMA Super-E[®] premium efficient motors

Conduit box volumes

Cast iron frames

Motor frame size	Baldor ECP volume mm ³ (in ³)	(NPT) Conduit hole size mm(in)
143T/145T	55716 (34)	19.05 (0.75)
182T/184T	62271 (38)	25.40 (1)
213T/215T	62271 (38)	25.40 (1)
254T/256T	104877 (64)	31.75 (1.25)
284T/286T	185173 (113)	38.10 (1.5)
324T/326T	424423 (259)	50.80 (2)
364T/365T	594848 (363)	76.20 (3)
404T/405T	594848 (363)	76.20 (3)
444T/445T	1153645 (704)	76.20 (3)
447T	1999214 (1220)	101.60 (4)
449T	1999214 (1220)	101.60 (4)

Steel band

Motor frame size	Baldor volume mm ³ (in ³)	UL/NEC Minimum volume mm ³ (in ³)	(NPT) Conduit hole size mm(in)
56	269,24 (10.6)	266,70 (10.5)	22,23 (0.875)
143T/145T	469,90 (18.5)	426,72 (16.8)	19,05 (0.75)
182T/184T	632,46 (24.9)	426,72 (16.8)	19,05 (0.75)
213T/215T	1010,92 (39.8)	924,56 (36.4)	25,40 (1)
254T/256T	2006.60 (79)	924,56 (36.4)	31,75 (1.25)

Approvals UL and CSA

All NEMA 42 through 445T, equivalent IEC frame motors (inverter and vector drive motors) are listed under UL recognized component file #E46145 and #E54825. All NEMA 42 through 449T frame motors are listed under CSA recognized component file #LR2262 and #LR7861.

NEMA Super-E[®] premium efficient motors

Dimension drawings

Steel band construction – TEFC

Foot mounted – NEMA 56 - 215T

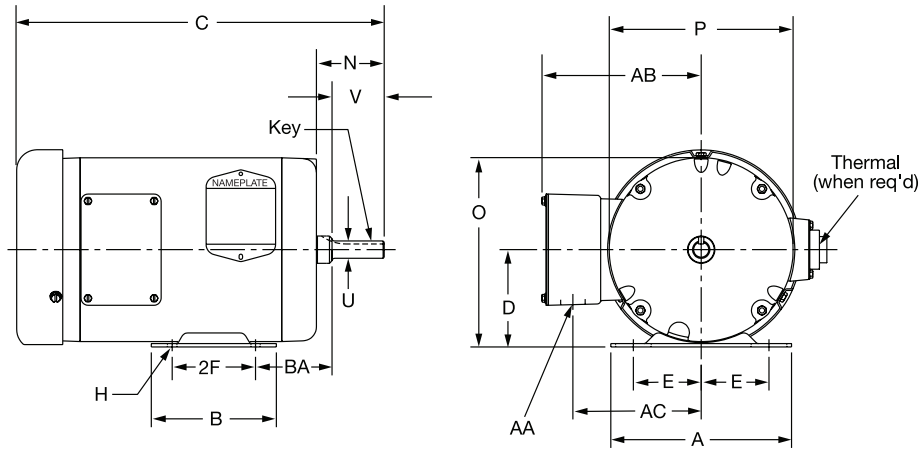

NEMA frame	A	B	D	E	2F	H	Key	N	O	P	U	V	AA	AB	AC	BA
56	165,10 (6.5)	114,30 (4.5)	88,90 (3.5)	61,98 (2.44)	76,20 (3)	8,64 (0.34) Slot	4,83 (0.19)	61,98 (2.44)	172,97 (6.81)	168,15 (6.62)	15,88 (0.625)	47,75 (1.88)	22,35 (0.88)	145,54 (5.73)	117,35 (4.62)	69,85 (2.75)
143T	165,10 (6.5)	150,88 (5.94)	88,90 (3.5)	69,85 (2.75)	101,60 (4)	8,64 (0.34)	4,83 (0.19)	63,50 (2.5)	172,97 (6.81)	168,15 (6.62)	22,23 (0.875)	57,15 (2.25)	22,35 (0.88)	145,54 (5.73)	117,35 (4.62)	57,15 (2.25)
145T	165,10 (6.5)	150,88 (5.94)	88,90 (3.5)	69,85 (2.75)	127,00 (5)	8,64 (0.34)	4,83 (0.19)	63,50 (2.5)	172,97 (6.81)	168,15 (6.62)	22,23 (0.875)	57,15 (2.25)	22,35 (0.88)	145,54 (5.73)	117,35 (4.62)	57,15 (2.25)
182T	219,20 (8.63)	165,10 (6.5)	114,30 (4.5)	95,25 (3.75)	114,30 (4.5)	10,41 (0.41)	6,35 (0.25)	90,42 (3.56)	214,38 (8.44)	200,15 (7.88)	28,58 (1.125)	69,85 (2.75)	27,69 (1.09)	174,50 (6.87)	146,30 (5.76)	69,85 (2.75)
184T	219,20 (8.63)	165,10 (6.5)	114,30 (4.5)	95,25 (3.75)	139,70 (5.5)	10,41 (0.41)	6,35 (0.25)	90,42 (3.56)	214,38 (8.44)	200,15 (7.88)	28,58 (1.125)	69,85 (2.75)	27,69 (1.09)	174,50 (6.87)	146,30 (5.76)	69,85 (2.75)
213T	241,30 (9.5)	203,20 (8)	133,35 (5.25)	107,95 (4.25)	139,70 (5.5)	10,41 (0.41)	7,87 (0.31)	98,55 (3.88)	254,76 (10.03)	243,08 (9.57)	34,93 (1.375)	85,85 (3.38)	35,05 (1.38)	204,47 (8.05)	172,47 (6.79)	88,90 (3.5)
215T	241,30 (9.5)	203,20 (8)	133,35 (5.25)	107,95 (4.25)	177,80 (7)	10,41 (0.41)	7,87 (0.31)	98,55 (3.88)	254,76 (10.03)	243,08 (9.57)	34,93 (1.375)	85,85 (3.38)	35,05 (1.38)	204,47 (8.05)	172,47 (6.79)	88,90 (3.5)

Note: Dimensions are in mm (in). Dimension for reference only. Contact your ABB regional support office for the detailed dimension drawing for your specific catalog number.

Steel band construction – TEFC & TENV

C-face foot mounted and footless – NEMA 56C - 215TC

TENV Enclosure

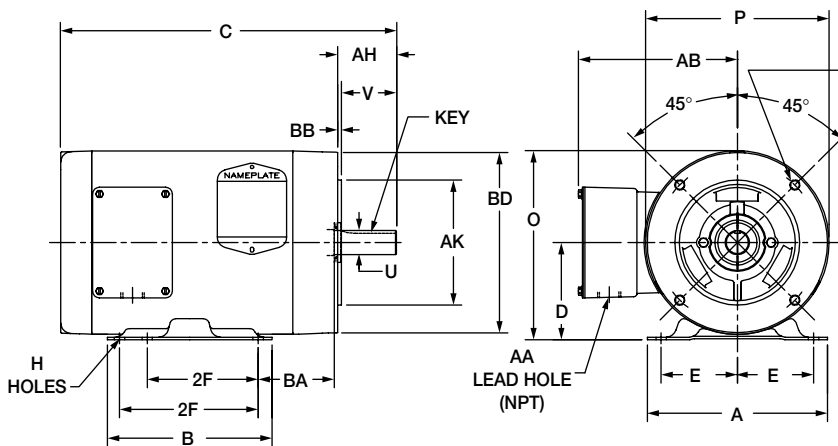

TEFC Enclosure

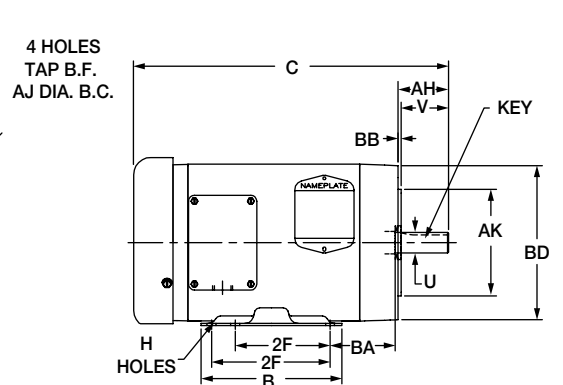

Catalog no. starting with "C" = C-face with base.
Catalog no. starting with "V" = C-face, no base.

NEMA frame	A	B	D	E	2F	H	O	P	U	V	AA	AB	AH	AJ	Tap * BF	AK	BA	BB	BD
56C	165,10 (6.5)	114,30 (4.5)	88,90 (3.5)	61,98 (2.44)	76,20 (3)	8,64 (0.34)	172,97 (6.81)	168,15 (6.62)	15,88 (0.625)	47,75 (1.88)	22,35 (0.88)	145,54 (5.73)	52,58 (2.07)	149,35 (5.88)	3/8-16	114,30 (4.5)	69,85 (2.75)	3,30 (0.13)	165,10 (6.5)
143TC	165,10 (6.5)	150,88 (5.94)	88,90 (3.5)	69,85 (2.75)	101,60 (4)	8,64 (0.34)	172,97 (6.81)	168,15 (6.62)	22,23 (0.875)	57,15 (2.25)	22,35 (0.88)	145,54 (5.73)	53,85 (2.12)	149,35 (5.88)	3/8-17	114,30 (4.5)	69,85 (2.75)	3,30 (0.13)	165,10 (6.5)
145TC	165,10 (6.5)	150,88 (5.94)	88,90 (3.5)	69,85 (2.75)	127,00 (5)	8,64 (0.34)	172,97 (6.81)	168,15 (6.62)	22,23 (0.875)	57,15 (2.25)	22,35 (0.88)	145,54 (5.73)	53,85 (2.12)	149,35 (5.88)	3/8-17	114,30 (4.5)	69,85 (2.75)	3,30 (0.13)	165,10 (6.5)
182TC	219,20 (8.63)	165,10 (6.5)	114,30 (4.5)	95,25 (3.75)	114,30 (4.5)	10,41 (0.41)	214,38 (8.44)	200,15 (7.88)	28,58 (1.125)	69,85 (2.75)	27,69 (1.09)	174,50 (6.87)	66,55 (2.62)	184,15 (7.25)	1/2-13	215,90 (8.5)	88,90 (3.5)	6,35 (0.25)	225,04 (8.86)
184TC	219,20 (8.63)	165,10 (6.5)	114,30 (4.5)	95,25 (3.75)	139,70 (5.5)	10,41 (0.41)	214,38 (8.44)	200,15 (7.88)	28,58 (1.125)	69,85 (2.75)	27,69 (1.09)	174,50 (6.87)	66,55 (2.62)	184,15 (7.25)	1/2-13	215,90 (8.5)	88,90 (3.5)	6,35 (0.25)	225,04 (8.86)
213TC	241,30 (9.5)	203,20 (8)	133,35 (5.25)	107,95 (4.25)	139,70 (5.5)	10,41 (0.41)	254,76 (10.03)	243,08 (9.57)	34,93 (1.375)	85,85 (3.38)	35,05 (1.38)	204,47 (8.05)	79,25 (3.12)	184,15 (7.25)	1/2-13	215,90 (8.5)	107,95 (4.25)	6,35 (0.25)	229,62 (9.04)
215TC	241,30 (9.5)	203,20 (8)	133,35 (5.25)	107,95 (4.25)	177,80 (7)	10,41 (0.41)	254,76 (10.03)	243,08 (9.57)	34,93 (1.375)	85,85 (3.38)	35,05 (1.38)	204,47 (8.05)	79,25 (3.12)	184,15 (7.25)	1/2-13	215,90 (8.5)	107,95 (4.25)	6,35 (0.25)	229,62 (9.04)

Note: Dimensions are in mm (in). Dimension for reference only. Contact your ABB regional support office for the detailed dimension drawing for your specific catalog number.

* Tap size specified are SAE thread size (no metric equivalent).

NEMA Super-E[®] premium efficient motors

Dimension drawings

Cast iron construction – TEFC
 Foot mounted
 NEMA 143T - 449T

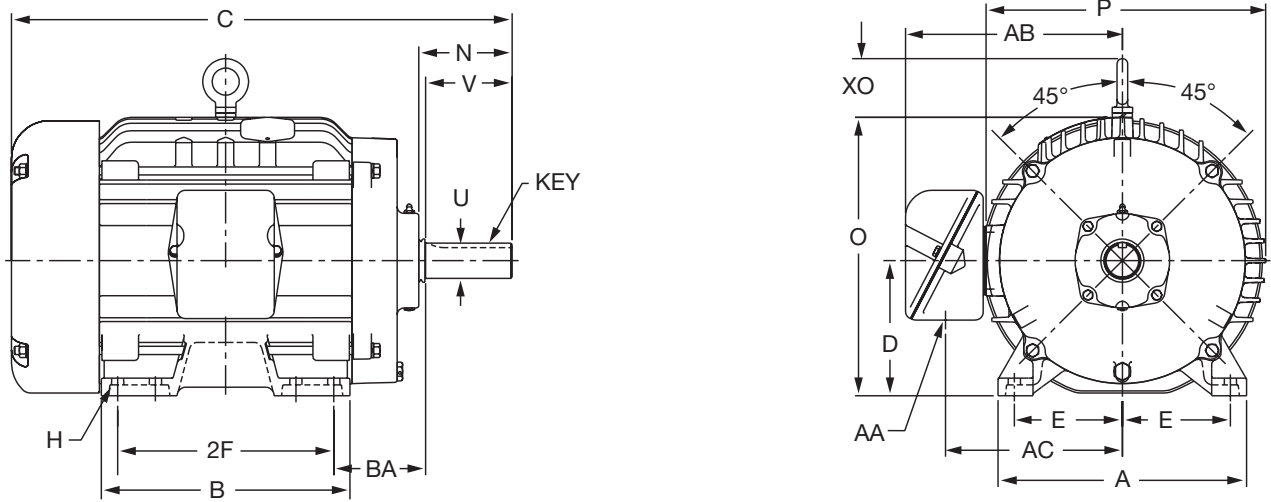

NEMA frame	A	B	D	E	2F	H	Key	N	O	P	U	V	AA	AB	AC	BA
143T	165,10	149,35	88,90	69,85	101,60 (4)	9,65	4,83	63,50	190,50	203,20	22,23	57,15	27,69	163,32	131,57	57,15
145T	(6.5)	(5.88)	(3.5)	(2.75)	127,00 (5)	(0.38)	(0.19)	(2.5)	(7.5)	(8)	(0.875)	(2.25)	(1.09)	(6.43)	(5.18)	(2.25)
182T	218,95	165,10	114,30	95,25	114,30 (4.5)	10,41	6,35	71,37	234,44	240,28	28,58	69,85	27,69	182,37	150,62	69,85
184T	(8.62)	(6.5)	(4.5)	(3.75)	139,70 (5.5)	(0.41)	(0.25)	(2.81)	(9.23)	(9.46)	(1.125)	(2.75)	(1.09)	(7.18)	(5.93)	(2.75)
213T	244,35	206,25	133,35	107,95	139,70 (5.5)	10,41	7,87	98,55	279,15	292,10	34,93	85,85	35,05	234,19	187,45	88,90
215T	(9.62)	(8.12)	(5.25)	(4.25)	177,80 (7)	(0.41)	(0.31)	(3.88)	(10.99)	(11.5)	(1.375)	(3.38)	(1.38)	(9.22)	(7.38)	(3.5)
254T	292,10	292,10	158,75	127,00	209,55 (8.25)	13,46	9,65	109,73	327,15	328,68	41,28	101,60	35,05	255,02	208,03	107,95
256T	(11.5)	(11.5)	(6.25)	(5)	254,00 (10)	(0.53)	(0.38)	(4.32)	(12.88)	(12.94)	(1.625)	(4)	(1.38)	(10.04)	(8.19)	(4.25)
284T	323,85	326,14	177,80	139,70	241,30 (9.5)	13,46	12,70	120,65	351,28	346,20	41,28	117,60	50,80	309,88	245,36	120,65
286T	(12.75)	(12.84)	(7)	(5.5)	279,40 (11)	(0.53)	(0.5)	(4.75)	(13.83)	(13.63)	(1.625)	(4.63)	(2)	(12.2)	(9.66)	(4.75)
284TS	323,85	326,14	177,80	139,70	241,30 (9.5)	13,46	9,65	85,60	351,28	346,20	41,28	82,55	50,80	309,88	245,36	120,65
286TS	(12.75)	(12.84)	(7)	(5.5)	279,40 (11)	(0.53)	(0.38)	(3.37)	(13.83)	(13.63)	(1.625)	(3.25)	(2)	(12.2)	(9.66)	(4.75)
324T	368,30	355,60	203,20	158,75	266,70 (10.5)	16,76	12,70	141,22	392,18	404,37	53,98	133,35	63,50	349,00	284,23	133,35
326T	(14.5)	(14)	(8)	(6.25)	304,80 (12)	(0.66)	(0.5)	(5.56)	(15.44)	(15.92)	(2.125)	(5.25)	(2.5)	(13.74)	(11.19)	(5.25)
324TS	368,30	355,60	203,20	158,75	266,70 (10.5)	16,76	12,70	103,12	392,18	404,37	47,63	95,25	63,50	349,00	284,23	133,35
326TS	(14.5)	(14)	(8)	(6.25)	304,80 (12)	(0.66)	(0.5)	(4.06)	(15.44)	(15.92)	(1.875)	(3.75)	(2.5)	(13.74)	(11.19)	(5.25)
364T	419,10	368,30	228,60	177,80	285,75 (11.25)	16,76	15,75	155,70	466,85	488,95	60,33	149,35	91,95	379,73	314,96	149,35
365T	(16.5)	(14.5)	(9)	(7)	311,15 (12.25)	(0.66)	(0.62)	(6.13)	(18.38)	(19.25)	(2.375)	(5.88)	(3.62)	(14.95)	(12.4)	(5.88)
364TS	419,10	368,30	228,60	177,80	285,75 (11.25)	16,76	12,70	101,60	466,85	488,95	47,63	95,25	91,95	379,73	314,96	149,35
365TS	(16.5)	(14.5)	(9)	(7)	311,15 (12.25)	(0.66)	(0.5)	(4)	(18.38)	(19.25)	(1.875)	(3.75)	(3.62)	(14.95)	(12.4)	(5.88)
404T	479,55	422,40	254,00	203,20	311,15 (12.25)	20,57	19,05	190,50	492,25	503,17	73,03	184,15	92,20	453,39	360,17	168,40
405T	(18.88)	(16.63)	(10)	(8)	349,25 (13.75)	(0.81)	(0.75)	(7.5)	(19.38)	(19.81)	(2.875)	(7.25)	(3.63)	(17.85)	(14.18)	(6.63)
404TS	482,60	406,40	254,00	203,20	311,15 (12.25)	20,57	12,70	114,30	541,27	571,50	53,98	101,60	76,20	490,47	387,35	168,15
405TS	(19)	(16)	(10)	(8)	349,25 (13.75)	(0.81)	(0.5)	(4.5)	(21.31)	(22.5)	(2.125)	(4)	(3)	(19.31)	(15.25)	(6.62)
444T	558,80	593,85	279,15	228,60	368,30 (14.5)	20,64	22,23	221,49	615,70	673,10	85,73	209,55	76,20	576,07	453,90	197,10
445T	(22)	(23.38)	(10.99)	(9)	419,10 (16.5)	(0.8125)	(0.875)	(8.72)	(24.24)	(26.5)	(3.375)	(8.25)	(3)	(22.68)	(17.87)	(7.76)
444TS	558,80	593,85	279,15	228,60	368,30 (14.5)	20,64	15,88	125,98	615,70	673,10	60,33	114,30	76,20	576,07	453,90	194,31
445TS	(22)	(23.38)	(10.99)	(9)	419,10 (16.5)	(0.8125)	(0.625)	(4.96)	(24.24)	(26.5)	(2.375)	(4.5)	(3)	(22.68)	(17.87)	(7.65)
445T	558,80	686,56	279,15	228,60	419,10 (16.5)	20,64	22,23	218,19	615,70	700,28	85,73	209,55	101,60	606,04	472,95	194,56
447T	(22)	(27.03)	(10.99)	(9)	508,00 (20)	(0.8125)	(0.875)	(8.59)	(24.24)	(27.57)	(3.375)	(8.25)	(4)	(23.86)	(18.62)	(7.66)
445TS	558,80	686,56	279,15	228,60	419,10 (16.5)	20,64	15,88	122,94	615,70	700,28	60,33	114,30	101,60	606,04	472,95	195,07
447TS	(22)	(27.03)	(10.99)	(9)	508,00 (20)	(0.8125)	(0.625)	(4.84)	(24.24)	(27.57)	(2.375)	(4.5)	(4)	(23.86)	(18.62)	(7.68)
447T	558,80	813,56	279,15	228,60	508,00 (20)	20,64	22,23	218,19	615,70	700,28	85,73	213,11	101,60	603,00	469,90	191,01
449T	(22)	(32.03)	(10.99)	(9)	635,00 (25)	(0.8125)	(0.875)	(8.59)	(24.24)	(27.57)	(3.375)	(8.39)	(4)	(23.74)	(18.5)	(7.52)
447TS	558,80	813,56	279,15	228,60	508,00 (20)	20,64	15,88	122,94	615,70	700,28	60,33	120,65	101,60	603,00	472,95	191,01
449TS	(22)	(32.03)	(10.99)	(9)	635,00 (25)	(0.8125)	(0.625)	(4.84)	(24.24)	(27.57)	(2.375)	(4.75)	(4)	(23.74)	(18.62)	(7.52)

Note: Dimensions are in mm (in).
 Dimension for reference only.
 Contact your ABB regional support office for the detailed dimension drawing for your specific catalog number.

NEMA Super-E[®] premium efficient motors

Dimension drawings

Dimensional layout for motors with note 99

Cast iron construction motors – TEFC

Swing arm mounted conduit box

NEMA 444T - L449T

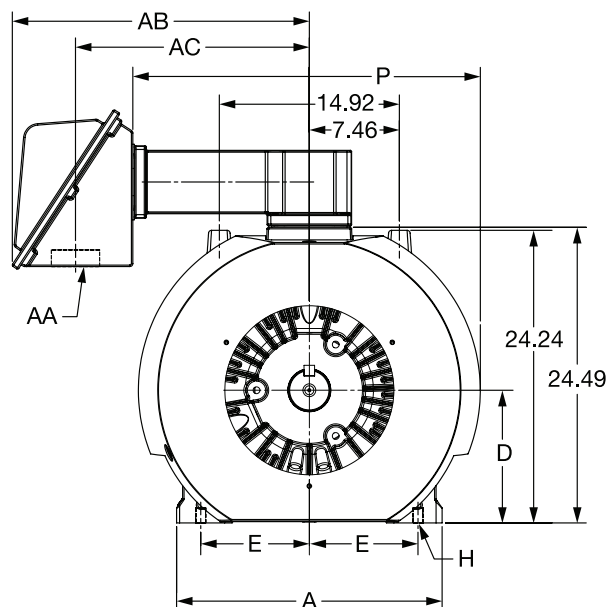
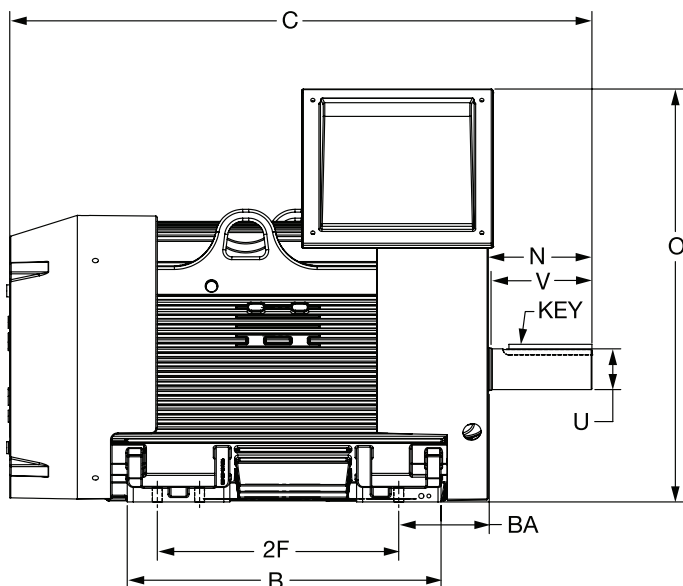

* For general purpose enclosures AA is a lead outlet hole.

* For severe duty enclosures (ECP) - AA is an N.P.T.

NEMA frame	A	B	D	E	2F	H	Key	N	O	P	U	V	AA*	AB	AC	BA
444T	558,80	567,69	279,15	228,60 (9)	368,30 (14.5)	20,64	22,23	221,49	853,19	731,01	85,73	212,34	91,44	623,57	492,00	194,56
445T	(22)	(22.35)	(10.99)		419,10 (16.5)	(0.8125)	(0.875)	(8.72)	(33.59)	(28.78)	(3.375)	(8.36)	(3.6)	(24.55)	(19.37)	(7.66)
444TS	558,80	567,69	279,15	228,60 (9)	368,30 (14.5)	20,64	15,88	125,98	853,19	731,01	60,33	117,35	91,44	623,57	492,00	194,06
445TS	(22)	(22.35)	(10.99)		419,10 (16.5)	(0.8125)	(0.625)	(4.96)	(33.59)	(28.78)	(2.375)	(4.62)	(3.6)	(24.55)	(19.37)	(7.64)
445T	558,80	660,40	279,15	228,60 (9)	419,10 (16.5)	20,64	22,23	218,19	868,93	731,01	85,73	212,34	101,60	625,09	492,00	190,50
447T	(22)	(26)	(10.99)		508,00 (20)	(0.8125)	(0.875)	(8.59)	(34.21)	(28.78)	(3.375)	(8.36)	(4)	(24.61)	(19.37)	(7.5)
445TS	558,80	660,40	279,15	228,60 (9)	419,10 (16.5)	20,64	15,88	122,94	868,93	731,01	60,33	120,65	101,60	625,09	492,00	190,50
447TS	(22)	(26)	(10.99)		508,00 (20)	(0.8125)	(0.625)	(4.84)	(34.21)	(28.78)	(2.375)	(4.75)	(4)	(24.61)	(19.37)	(7.5)
447T	558,80	787,40	279,15	228,60 (9)	508,00 (20)	20,64	22,23	218,19	868,17	727,20	85,73	215,90	101,60	621,54	488,19	190,75
449T	(22)	(31)	(10.99)		635,00 (25)	(0.8125)	(0.875)	(8.59)	(34.18)	(28.63)	(3.375)	(8.5)	(4)	(24.47)	(19.22)	(7.51)
447TS	558,80	787,40	279,15	228,60 (9)	508,00 (20)	20,64	15,88	122,94	868,17	727,20	60,33	120,65	101,60	621,54	488,19	189,23
449TS	(22)	(31)	(10.99)		635,00 (25)	(0.8125)	(0.625)	(4.84)	(34.18)	(28.63)	(2.375)	(4.75)	(4)	(24.47)	(19.22)	(7.45)
449T	558,80	966,22	279,15	228,60 (9)	635,00 (25)	20,64	22,23	217,42	868,93	727,20	85,73	212,60	101,60	625,09	492,00	193,55
L449TS	(22)	(38.04)	(10.99)		812,80 (32)	(0.8125)	(0.875)	(8.56)	(34.21)	(28.63)	(3.375)	(8.37)	(4)	(24.61)	(19.37)	(7.62)
449TS	558,80	966,22	279,15	228,60 (9)	635,00 (25)	20,64	15,88	122,17	868,93	731,01	60,33	117,35	101,60	625,09	492,00	193,55
L449TS	(22)	(38.04)	(10.99)		812,80 (32)	(0.8125)	(0.625)	(4.81)	(34.21)	(28.78)	(2.375)	(4.62)	(4)	(24.61)	(19.37)	(7.62)

Note: Dimensions are in mm (in).

Dimension for reference only.

Contact your ABB regional support office for the detailed dimension drawing for your specific catalog number.

NEMA Super-E[®] premium efficient motors

Dimension drawings

Cast iron construction – TEFC
 C-face foot mounted
 NEMA 143TC - 405TC

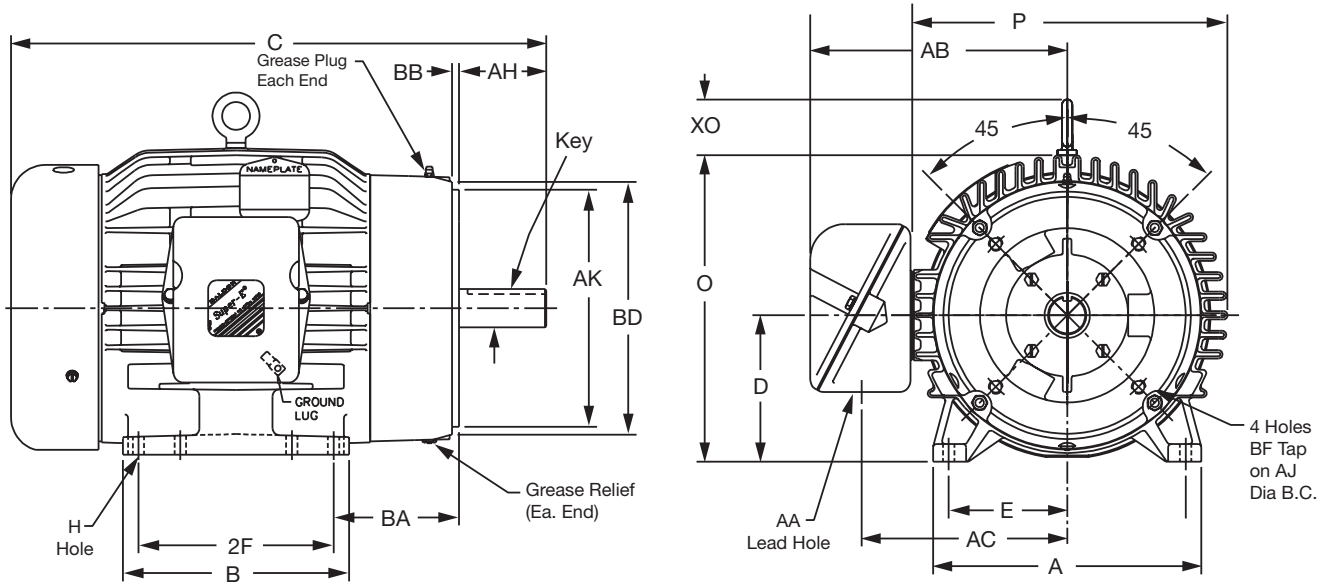

NEMA frame	A	B	D	E	2F	H	Key	O	P	U	V	AA	AB	AC	AH	AJ	AK	BB	BD	Tap * BF	BA
143TC	165,10	149,35	88,90	69,85	101,60 (4)	9,65	4,83	190,50	203,20	22,23	51,05	27,69	161,80	131,83	53,85	149,35	114,30	3,30	164,34	3/8-16	69,85
145TC	(6.5)	(5.88)	(3.5)	(2.75)	127,00 (5)	(0.38)	(0.19)	(7.5)	(8)	(0.875)	(2.01)	(1.09)	(6.37)	(5.19)	(2.12)	(5.88)	(4.5)	(0.13)	(6.47)		(2.75)
182TC	218,95	165,10	114,30	95,25	114,30 (4.5)	10,41	6,35	234,44	240,28	28,58	66,55	27,69	182,37	150,62	69,85	184,15	215,90	6,35	228,60	1/2-13	88,90
184TC	(8.62)	(6.5)	(4.5)	(3.75)	139,70 (5.5)	(0.41)	(0.25)	(9.23)	(9.46)	(1.125)	(2.62)	(1.09)	(7.18)	(5.93)	(2.75)	(7.25)	(8.5)	(0.25)	(9)		(3.5)
213TC	244,35	206,25	133,35	107,95	139,70 (5.5)	10,41	7,87	279,15	292,10	34,93	85,85	35,05	233,93	187,20	79,50	184,15	215,90	6,35	230,12	1/2-13	114,30
215TC	(9.62)	(8.12)	(5.25)	(4.25)	177,80 (7)	(0.41)	(0.31)	(10.99)	(11.5)	(1.375)	(3.38)	(1.38)	(9.21)	(7.37)	(3.13)	(7.25)	(8.5)	(0.25)	(9.06)		(4.5)
254TC	292,10	292,10	158,75	127,00	209,55 (8.25)	13,46	9,65	327,15	328,68	41,28	101,60	35,05	255,02	208,03	95,25	184,15	215,90	6,35	230,89	1/2-13	120,65
256TC	(11.5)	(11.5)	(6.25)	(5)	254,00 (10)	(0.53)	(0.38)	(12.88)	(12.94)	(1.625)	(4)	(1.38)	(10.04)	(8.19)	(3.75)	(7.25)	(8.5)	(0.25)	(9.09)		(4.75)
284TC	323,85	326,14	177,80	139,70	241,30 (9.5)	13,46	12,70	366,78	388,62	47,63	117,60	50,80	332,99	268,22	111,25	228,60	266,70	6,35	284,73	1/2-13	120,65
286TC	(12.75)	(12.84)	(7)	(5.5)	279,40 (11)	(0.53)	(0.5)	(14.44)	(15.3)	(1.875)	(4.63)	(2)	(13.11)	(10.56)	(4.38)	(9)	(10.5)	(0.25)	(11.21)		(4.75)
284TSC	323,85	326,14	177,80	139,70	241,30 (9.5)	13,46	9,65	366,78	388,62	41,28	82,55	50,80	333,25	268,22	76,20	228,60	266,70	6,35	284,73	1/2-13	120,65
286TSC	(12.75)	(12.84)	(7)	(5.5)	279,40 (11)	(0.53)	(0.38)	(14.44)	(15.3)	(1.625)	(3.25)	(2)	(13.12)	(10.56)	(3)	(9)	(10.5)	(0.25)	(11.21)		(4.75)
324TC	368,30	355,60	203,20	158,75	266,70 (10.5)	16,76	12,70	412,75	453,39	53,98	133,35	63,50	371,09	306,32	127,00	279,40	317,50	6,35	340,36	5/8-11	133,35
326TC	(14.5)	(14)	(8)	(6.25)	304,80 (12)	(0.66)	(0.5)	(16.25)	(17.85)	(2.125)	(5.25)	(2.5)	(14.61)	(12.06)	(5)	(11)	(12.5)	(0.25)	(13.4)		(5.25)
324TSC	368,30	355,60	203,20	158,75	266,70 (10.5)	16,76	12,70	412,75	453,39	47,63	95,25	63,50	371,60	306,58	88,90	279,40	317,50	6,35	340,36	5/8-11	133,35
326TSC	(14.5)	(14)	(8)	(6.25)	304,80 (12)	(0.66)	(0.5)	(16.25)	(17.85)	(1.875)	(3.75)	(2.5)	(14.63)	(12.07)	(3.5)	(11)	(12.5)	(0.25)	(13.4)		(5.25)
364TC	431,80	381,00	228,60	177,80	285,75 (11.25)	17,53	15,88	469,90	495,30	60,33	142,75	76,20	459,23	355,60	142,75	279,40	317,50	6,35	330,20	5/8-11	149,35
365TC	(17)	(15)	(9)	(7)	311,15 (12.25)	(0.69)	(0.625)	(18.5)	(19.5)	(2.375)	(5.62)	(3)	(18.08)	(14)	(5.62)	(11)	(12.5)	(0.25)	(13)		(5.88)
364TSC	431,80	381,00	228,60	177,80	285,75 (11.25)	17,53	12,70	469,90	495,30	47,63	88,90	76,20	459,23	355,60	88,90	279,40	317,50	6,35	330,20	5/8-11	149,35
365TSC	(17)	(15)	(9)	(7)	311,15 (12.25)	(0.69)	(0.5)	(18.5)	(19.5)	(1.875)	(3.5)	(3)	(18.08)	(14)	(3.5)	(11)	(12.5)	(0.25)	(13)		(5.88)
404TC	479,55	422,40	254,00	203,20	311,15 (12.25)	20,57	19,05	541,27	571,50	73,03	177,80	76,20	490,47	387,35	177,80	279,40	317,50	6,35	333,25	5/8-11	168,15
405TC	(18.88)	(16.63)	(10)	(8)	349,25 (13.75)	(0.81)	(0.75)	(21.31)	(22.5)	(2.875)	(7)	(3)	(19.31)	(15.25)	(7)	(11)	(12.5)	(0.25)	(13.12)		(6.62)

Note: Dimensions are in mm (in).
 Dimension for reference only.

Contact your ABB regional support office for the detailed dimension drawing for your specific catalog number.

* Tap size specified are SAE thread size (no metric equivalent).

NEMA Super-E[®] premium efficient motors

Dimension drawings

Cast iron construction – TEFC

C-face footless

NEMA 56C - 256TC

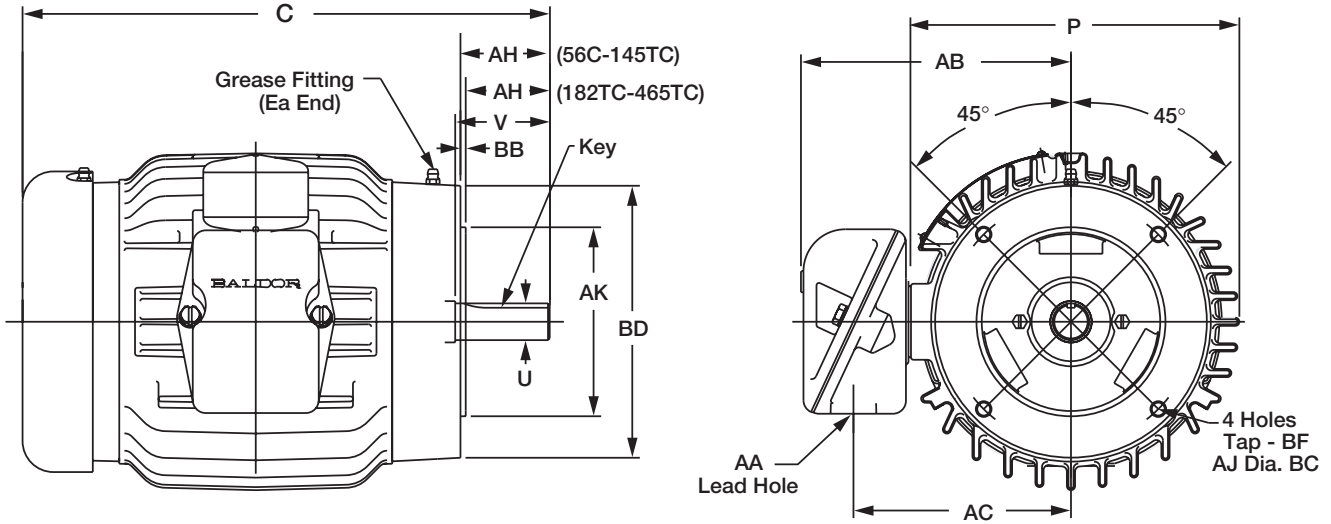

NEMA frame	Key	P	U	V	AA	AB	AC	AH	AJ	AK	BB	BD	Tap * BF
56C	4,83 (0.19)	203,20 (8)	15,88 (0.625)	47,75 (1.88)	27,69 (1.09)	162,56 (6.4)	130,05 (5.12)	52,32 (2.06)	149,35 (5.88)	114,30 (4.5)	3,30 (0.13)	164,34 (6.47)	3/8-16
143TC	4,83 (0.19)	203,20 (8)	22,23 (0.875)	57,15 (2.25)	27,69 (1.09)	161,54 (6.36)	131,32 (5.17)	53,85 (2.12)	149,35 (5.88)	114,30 (4.5)	3,30 (0.13)	164,34 (6.47)	3/8-16
182TC	6,35 (0.25)	257,05 (10.12)	28,58 (1.125)	69,85 (2.75)	27,69 (1.09)	182,37 (7.18)	150,62 (5.93)	66,55 (2.62)	184,15 (7.25)	215,90 (8.5)	6,35 (0.25)	228,60 (9)	1/2-13
184TC	6,35 (0.25)	257,05 (10.12)	28,58 (1.125)	69,85 (2.75)	27,69 (1.09)	182,37 (7.18)	150,62 (5.93)	66,55 (2.62)	184,15 (7.25)	215,90 (8.5)	6,35 (0.25)	228,60 (9)	1/2-13
213TC	7,87 (0.31)	292,10 (11.5)	34,93 (1.375)	79,50 (3.13)	35,05 (1.38)	234,19 (9.22)	187,45 (7.38)	79,50 (3.13)	184,15 (7.25)	215,90 (8.5)	6,35 (0.25)	230,12 (9.06)	1/2-13
215TC	7,87 (0.31)	292,10 (11.5)	34,93 (1.375)	79,50 (3.13)	35,05 (1.38)	234,19 (9.22)	187,45 (7.38)	79,50 (3.13)	184,15 (7.25)	215,90 (8.5)	6,35 (0.25)	230,12 (9.06)	1/2-13
254TC	9,65 (0.38)	328,68 (12.94)	41,28 (1.625)	95,25 (3.75)	35,05 (1.38)	255,02 (10.04)	208,03 (8.19)	95,25 (3.75)	184,15 (7.25)	215,90 (8.5)	6,35 (0.25)	230,89 (9.09)	1/2-13
256TC	9,65 (0.38)	328,68 (12.94)	41,28 (1.625)	95,25 (3.75)	35,05 (1.38)	255,02 (10.04)	208,03 (8.19)	95,25 (3.75)	184,15 (7.25)	215,90 (8.5)	6,35 (0.25)	230,89 (9.09)	1/2-13

Note: Dimensions are in mm (in).

Dimension for reference only.

Contact your ABB regional support office for the detailed dimension drawing for your specific catalog number.

* Tap size specified are SAE tread size (no metric equivalent).

NEMA Super-E[®] premium efficient motors

Dimension drawings

Steel band construction – open drip-proof
 Foot mounted
 NEMA 48 through 405TS

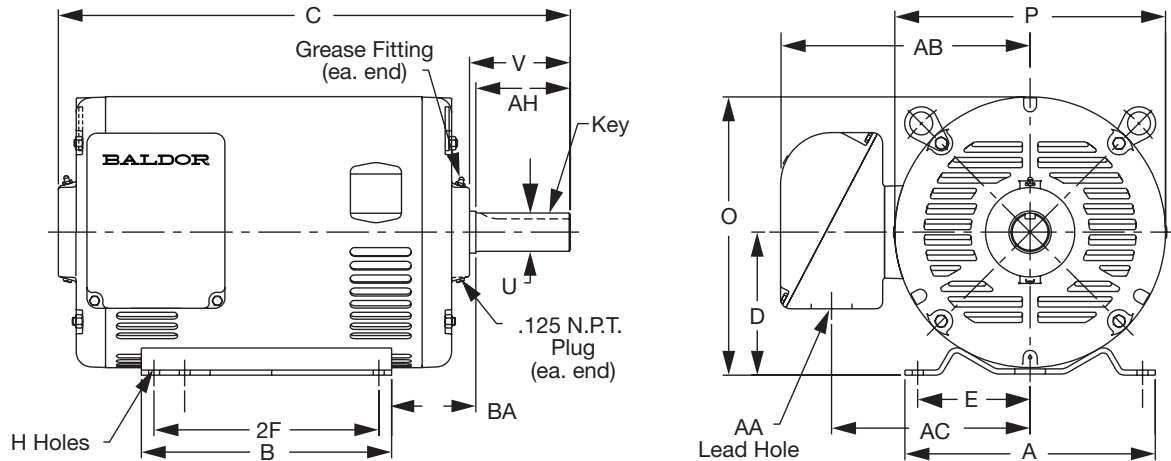

NEMA frame	A	B	D	E	2F	H	Key	O	P	U	V	AA	AB	AC	BA
48	146,05 (5.75)	101,60 (4.00)	76,20 (3)	53,85 (2.12)	69,85 (2.75)	8,64 (0.34)	Flat	147,57 (5.81)	144,53 (5.69)	12,70 (0.50)	38,10 (1.50)	12,70 (0.50)	111,25 (4.38)	89,92 (3.54)	63,50 (2.50)
56	165,10 (6.5)	114,30 (4.5)	88,90 (3.5)	61,98 (2.44)	76,20 (3)	8,64 (0.34)	4,83 (0.19)	172,97 (6.81)	168,15 (6.62)	15,88 (0.625)	47,75 (1.88)	22,35 (0.88)	142,49 (5.61)	115,82 (4.56)	69,85 (2.75)
143T	165,10 (6.5)	150,88 (5.94)	88,90 (3.5)	69,85 (2.75)	101,60 (4)	8,64 (0.34)	4,83 (0.19)	172,97 (6.81)	168,15 (6.62)	22,23 (0.875)	57,15 (2.25)	22,35 (0.88)	142,49 (5.61)	115,82 (4.56)	57,15 (2.25)
145T					127,00 (5)										
182T	219,20 (8.63)	165,10 (6.5)	114,30 (4.5)	95,25 (3.75)	114,30 (4.5)	10,41 (0.41)	6,35 (0.25)	214,38 (8.44)	200,15 (7.88)	28,58 (1.125)	69,85 (2.75)	27,69 (1.09)	171,45 (6.75)	144,78 (5.7)	69,85 (2.75)
184T					139,70 (5.5)										
213T	241,30 (9.5)	203,20 (8)	133,35 (5.25)	107,95 (4.25)	139,70 (5.5)	10,41 (0.41)	7,87 (0.31)	254,76 (10.03)	243,08 (9.57)	34,93 (1.375)	85,85 (3.38)	35,05 (1.38)	201,42 (7.93)	170,94 (6.73)	88,90 (3.5)
215T					177,80 (7)										
254T	285,75 (11.25)	285,75 (11.25)	158,75 (6.25)	127,00 (5)	209,55 (8.25)	13,46 (0.53)	9,65 (0.38)	304,80 (12)	296,93 (11.69)	41,28 (1.625)	101,60 (4)	35,05 (1.38)	241,05 (9.49)	195,33 (7.69)	107,95 (4.25)
256T					254,00 (10)										
284T	311,15 (12.25)	311,15 (12.25)	177,80 (7)	139,70 (5.5)	241,30 (9.5)	13,46 (0.53)	12,70 (0.5)	346,20 (13.63)	336,55 (13.25)	41,28 (1.625)	117,60 (4.63)	50,80 (2)	313,18 (12.33)	248,41 (9.78)	120,65 (4.75)
286T					279,40 (11)										
284TS	311,15 (12.25)	311,15 (12.25)	177,80 (7)	139,70 (5.5)	241,30 (9.5)	13,46 (0.53)	9,65 (0.38)	346,20 (13.63)	336,55 (13.25)	41,28 (1.625)	82,55 (3.25)	50,80 (2)	313,18 (12.33)	248,41 (9.78)	120,65 (4.75)
286TS					279,40 (11)										
324T	356,62 (14.04)	342,90 (13.5)	203,20 (8)	158,75 (6.25)	266,70 (10.5)	16,76 (0.66)	12,70 (0.5)	395,99 (15.59)	385,83 (15.19)	53,98 (2.125)	133,35 (5.25)	63,50 (2.5)	338,33 (13.32)	273,56 (10.77)	133,35 (5.25)
326T					304,80 (12)										
324TS	356,62 (14.04)	342,90 (13.5)	203,20 (8)	158,75 (6.25)	266,70 (10.5)	16,76 (0.66)	12,70 (0.5)	395,99 (15.59)	385,83 (15.19)	47,63 (1.875)	95,25 (3.75)	50,80 (2)	335,79 (13.22)	272,03 (10.71)	133,35 (5.25)
326TS					304,80 (12)										
364T	400,05 (15.75)	355,60 (14)	228,60 (9)	177,80 (7)	285,75 (11.25)	16,76 (0.66)	15,75 (0.62)	421,39 (16.59)	384,05 (15.12)	60,33 (2.375)	149,35 (5.88)	91,95 (3.62)	335,28 (13.2)	272,03 (10.71)	149,35 (5.88)
365T					311,15 (12.25)										
364TS	400,05 (15.75)	355,60 (14)	228,60 (9)	177,80 (7)	285,75 (11.25)	16,76 (0.66)	12,70 (0.5)	421,39 (16.59)	385,83 (15.19)	47,63 (1.875)	95,25 (3.75)	91,95 (3.62)	335,28 (13.2)	272,03 (10.71)	149,35 (5.88)
365TS					311,15 (12.25)										
404T	469,65 (18.49)	422,15 (16.62)	254,00 (10)	203,20 (8)	311,15 (12.25)	20,57 (0.81)	19,05 (0.75)	467,61 (18.41)	426,97 (16.81)	73,03 (2.875)	184,15 (7.25)	91,95 (3.62)	416,31 (16.39)	323,85 (12.75)	168,40 (6.63)
405T					349,25 (13.75)										
404TS	469,65 (18.49)	422,15 (16.62)	254,00 (10)	203,20 (8)	311,15 (12.25)	20,57 (0.81)	12,70 (0.5)	467,61 (18.41)	426,97 (16.81)	53,98 (2.125)	107,95 (4.25)	91,95 (3.62)	416,31 (16.39)	323,85 (12.75)	168,40 (6.63)
405TS					349,25 (13.75)										

Note: Dimensions are in mm (in).

Dimension for reference only.

Contact your ABB regional support office for the detailed dimension drawing for your specific catalog number.

NEMA Super-E[®] premium efficient motors

Dimension drawings

Cast iron construction – open drip-proof
 Foot mounted
 NEMA 254T - 449T

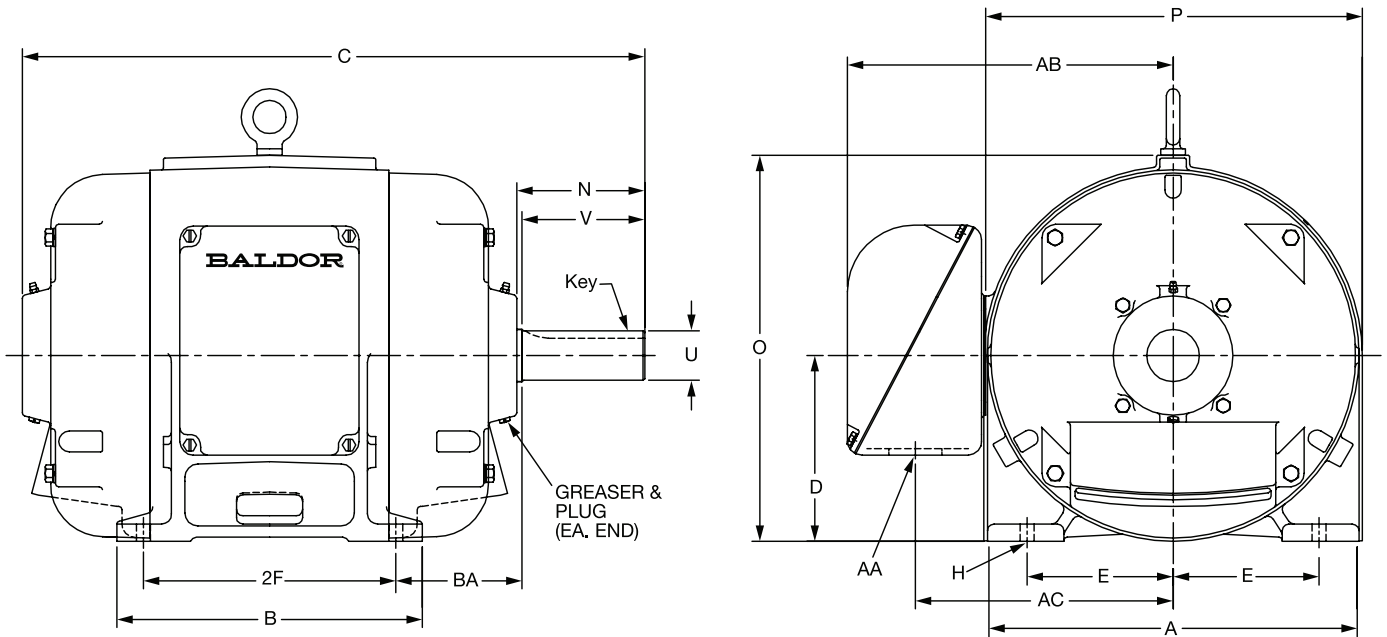

NEMA frame	A	B	D	E	2F	H	Key	N	O	P	U	V	AA	AB	AC	BA
254T	320,80 (12.63)	247,65 (9.75)	158,75 (6.25)	127,00 (5)	209,55 (8,25)	13,46 (0.53)	9,65 (0.38)	107,19 (4,22)	332,99 (13,11)	320,80 (12,63)	41,28 (1,625)	101,60 (4)	35,05 (1,38)	238,00 (9,37)	201,68 (7,94)	107,95 (4,25)
256T	320,80 (12.63)	292,10 (11.5)	158,75 (6.25)	127,00 (5)	254,00 (10)	13,46 (0.53)	9,65 (0.38)	107,19 (4,22)	332,99 (13,11)	320,80 (12,88)	41,28 (1,625)	101,60 (4)	35,05 (1,38)	244,35 (9,62)	208,03 (8,19)	107,95 (4,25)
284T	352,55 (13.88)	292,10 (11.5)	177,80 (7)	139,70 (5.5)	241,30 (9.5)	13,46 (0.53)	12,70 (0.5)	122,43 (4,82)	369,82 (14,56)	327,15 (14,06)	47,63 (1,875)	117,60 (4,63)	50,80 (2)	311,66 (12,27)	246,89 (9,72)	120,65 (4,75)
286T	352,55 (13.88)	330,20 (13)	177,80 (7)	139,70 (5.5)	279,40 (11)	13,46 (0.53)	12,70 (0.5)	120,65 (4,75)	369,82 (14,56)	357,12 (14,06)	47,63 (1,875)	117,60 (4,63)	50,80 (2)	308,61 (12,15)	245,36 (9,66)	120,65 (4,75)
286TS	352,55 (13.88)	330,20 (13)	177,80 (7)	139,70 (5.5)	279,40 (11)	13,46 (0.53)	9,65 (0.38)	87,38 (3,44)	369,82 (14,56)	357,12 (14,06)	41,28 (1,625)	82,55 (3,25)	50,80 (2)	308,61 (12,15)	245,36 (9,66)	120,65 (4,75)
324T	403,35 (15.88)	327,15 (12.88)	203,20 (8)	158,75 (6.25)	266,70 (10.5)	16,76 (0.66)	12,70 (0.5)	136,65 (5,38)	423,67 (16,68)	357,12 (16,21)	53,98 (2,125)	133,35 (5,25)	50,80 (2)	335,03 (13,19)	271,78 (10,7)	133,35 (5,25)
324TS	403,35 (15.88)	330,20 (13)	203,20 (8)	158,75 (6.25)	266,70 (10.5)	16,76 (0.66)	12,70 (0.5)	98,30 (3,87)	423,67 (16,68)	411,73 (16,21)	47,63 (1,875)	95,25 (3,75)	50,80 (2)	335,03 (13,19)	271,78 (10,7)	133,35 (5,25)
326T	403,35 (15.88)	368,30 (14.5)	203,20 (8)	158,75 (6.25)	304,80 (12)	16,76 (0.66)	12,70 (0.5)	136,65 (5,38)	423,67 (16,68)	411,73 (16,21)	53,98 (2,125)	133,35 (5,25)	50,80 (2)	335,03 (13,19)	271,78 (10,7)	133,35 (5,25)
364T 365T	431,80 (17)	361,95 (14.25)	228,60 (9)	177,80 (7)	285,75 (11.25) 311,15 (12.25)	17,53 (0.69)	15,88 (0.625)	155,45 (6,12)	464,82 (18,3)	411,73 (19,56)	60,33 (2,375)	142,75 (5,62)	76,20 (3)	458,72 (18,06)	355,60 (14)	149,35 (5,88)
364TS 365TS	431,80 (17)	361,95 (14.25)	228,60 (9)	177,80 (7)	285,75 (11.25) 311,15 (12.25)	17,53 (0.69)	12,70 (0.5)	101,60 (4)	464,82 (18,3)	496,82 (19,56)	47,63 (1,875)	88,90 (3,5)	76,20 (3)	458,72 (18,06)	355,60 (14)	149,35 (5,88)
404T 405T	482,60 (19)	406,40 (16)	254,00 (10)	203,20 (8)	311,15 (12.25) 349,25 (13.75)	20,57 (0.81)	19,05 (0.75)	193,55 (7,62)	522,22 (20,56)	496,82 (21,81)	73,03 (2,875)	177,80 (7)	76,20 (3)	484,12 (19,06)	381,00 (15)	168,15 (6,62)
404TS 405TS	482,60 (19)	406,40 (16)	254,00 (10)	203,20 (8)	311,15 (12.25) 349,25 (13.75)	20,57 (0.81)	12,70 (0.5)	117,35 (4,62)	522,22 (20,56)	553,97 (21,81)	53,98 (2,125)	101,60 (4)	76,20 (3)	484,12 (19,06)	381,00 (15)	168,15 (6,62)
444T 445T	533,40 (21)	482,60 (19)	279,40 (11)	228,60 (9)	368,30 (14.5) 419,10 (16.5)	20,57 (0.81)	22,23 (0.875)	227,08 (8,94)	581,91 (22,91)	553,97 (23,62)	85,73 (3,375)	209,55 (8,25)	76,20 (3)	574,55 (22,62)	441,45 (17,38)	190,50 (7,5)
444TS 445TS	533,40 (21)	482,60 (19)	279,40 (11)	228,60 (9)	368,30 (14.5) 419,10 (16.5)	20,57 (0.81)	15,88 (0.625)	131,83 (5,19)	581,91 (22,91)	599,95 (23,62)	60,33 (2,375)	114,30 (4,5)	76,20 (3)	574,55 (22,62)	441,45 (17,38)	190,50 (7,5)
447T	533,40 (21)	571,50 (22.5)	279,40 (11)	228,60 (9)	508,00 (20)	20,57 (0.81)	22,23 (0.875)	227,08 (8,94)	615,95 (24,25)	599,95 (24,25)	85,73 (3,375)	209,55 (8,25)	101,60 (4)	577,85 (22,75)	444,50 (17,5)	190,50 (7,5)
447TS	533,40 (21)	571,50 (22.5)	279,40 (11)	228,60 (9)	508,00 (20)	20,57 (0.81)	15,88 (0.625)	131,83 (5,19)	615,95 (24,25)	615,95 (24,25)	60,33 (2,375)	114,30 (4,5)	101,60 (4)	577,85 (22,75)	444,50 (17,5)	190,50 (7,5)
449T	533,40 (21)	698,50 (27.5)	279,40 (11)	228,60 (9)	635,00 (25)	20,57 (0.81)	22,23 (0.875)	227,08 (8,94)	615,95 (24,25)	615,95 (24,25)	85,73 (3,375)	213,11 (8,39)	101,60 (4)	577,85 (22,75)	444,50 (17,5)	190,50 (7,5)
449TS	533,40 (21)	698,50 (27.5)	279,40 (11)	228,60 (9)	635,00 (25)	20,57 (0.81)	15,88 (0.625)	131,83 (5,19)	615,95 (24,25)	615,95 (24,25)	60,33 (2,375)	114,30 (4,5)	101,60 (4)	577,85 (22,75)	444,50 (17,5)	190,50 (7,5)

Note: Dimensions are in mm (in). Dimension for reference only. Contact your ABB regional support office for the detailed dimension drawing for your specific catalog number.

NEMA Super-E[®] premium efficient motors

Dimension drawings

Brake motors - steel band construction
 Foot mounted
 NEMA 56 - 215T

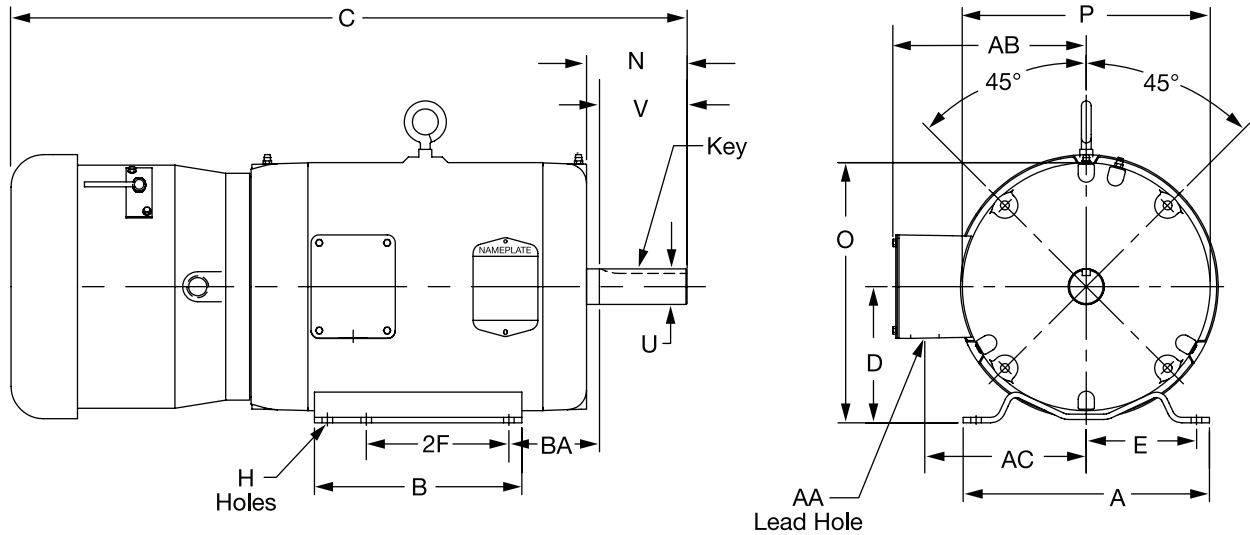

	NEMA frame	A	B	D	E	2F	H	Key	N	O	P	U	V	AA	AB	AC	BA
EBM TENV	56	165,10 (6.5)	114,30 (4.5)	88,90 (3.5)	61,98 (2.44)	76,20 (3)	8,64 Slot (0.34)	4,83 (0.19)	61,98 (2.44)	172,97 (6.81)	168,40 (6.63)	15,88 (0.625)	47,75 (1.88)	22,35 (0.88)	146,05 (5.75)	117,35 (4.62)	69,85 (2.75)
EBM TEFC	143T	165,10 (6.5)	150,88 (5.94)	88,90 (3.5)	69,85 (2.75)	101,60 (4)	8,64 (0.34)	4,83 (0.19)	63,50 (2.5)	172,97 (6.81)	168,15 (6.62)	22,23 (0.875)	57,15 (2.25)	22,35 (0.88)	132,59 (5.22)	106,17 (4.18)	69,85 (2.75)
EBM TEFC	182T	219,20 (8.63)	165,10 (6.5)	114,30 (4.5)	95,25 (3.75)	114,30 (4.5)	8,64 (0.34)	6,35 (0.25)	90,42 (3.56)	214,38 (8.44)	200,41 (7.89)	28,58 (1.125)	69,85 (2.75)	27,69 (1.09)	151,64 (5.97)	125,48 (4.94)	69,85 (2.75)
EBM TEFC	213T	241,30 (9.5)	203,20 (8)	133,35 (5.25)	107,95 (4.25)	139,70 (5.5)	10,41 (0.41)	7,87 (0.31)	98,55 (3.88)	254,76 (10.03)	242,82 (9.56)	34,93 (1.375)	85,85 (3.38)	27,69 (1.09)	204,47 (8.05)	172,47 (6.79)	88,90 (3.5)

Note: Dimensions are in mm (in).
 Dimension for reference only.
 Contact your ABB regional support office for the detailed dimension drawing for your specific catalog number.

NEMA Super-E[®] premium efficient motors

Dimension drawings

Brake motors – cast iron construction
 Foot mounted
 NEMA 254T - 286T

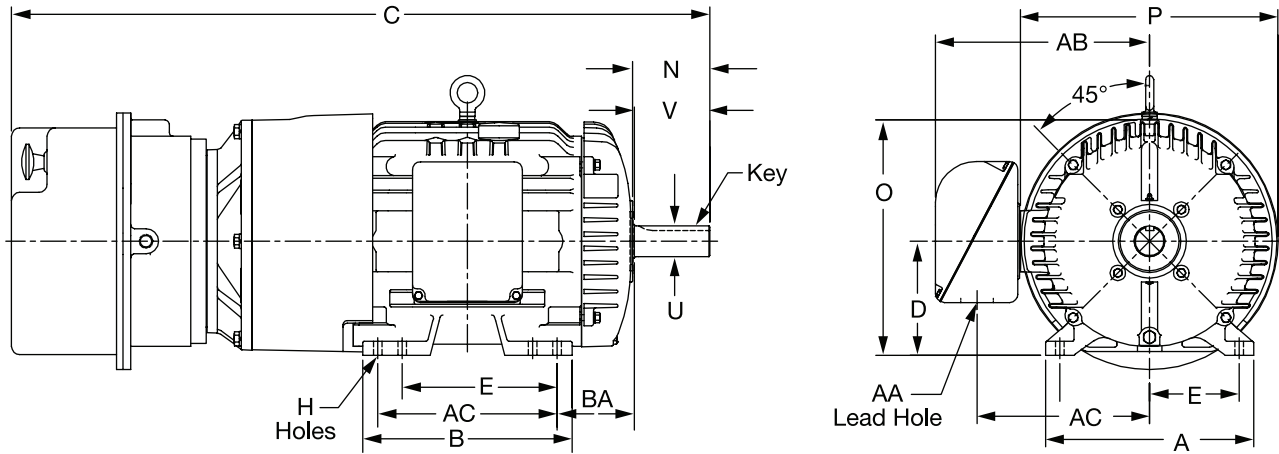

	NEMA frame	A	B	D	E	2F	H	Key	N	O	P	U	V	AA	AB	AC	BA
EBM TEFC	254T	292,10	292,10	158,75	127,00	209,55 (8.25)	13,46	9,6	109,73	327,15	328,68	41,28	101,60	35,05	241,05	202,95	107,95
	256T	(11.5)	(11.5)	(6.25)	(5)	254,00 (10)	(0.53)	(0.38)	(4.32)	(12.88)	(12.94)	(1.625)	(4)	(1.38)	(9.49)	(7.99)	(4.25)
EBM TEFC	284T	323,85	326,14	177,80	139,70	241,30 (9.5)	13,46	12,70	120,65	366,78	399,29	47,63	117,60	50,80 (2)	332,99	268,22	120,65
	286T	(12.75)	(12.84)	(7)	(5.5)	279,40 (11)	(0.53)	(0.5)	(4.75)	(14.44)	(15.72)	(1.875)	(4.63)		(13.11)	(10.56)	(4.75)

Note: Dimensions are in mm (in).
 Dimension for reference only.

Contact your ABB regional support office for the detailed dimension drawing for your specific catalog number.

NEMA Super-E[®] premium efficient motors

Dimension drawings

P-base vertical solid shaft pump motors
 Cast iron construction – TEFC
 NEMA 182HP - 365HP (normal thrust)

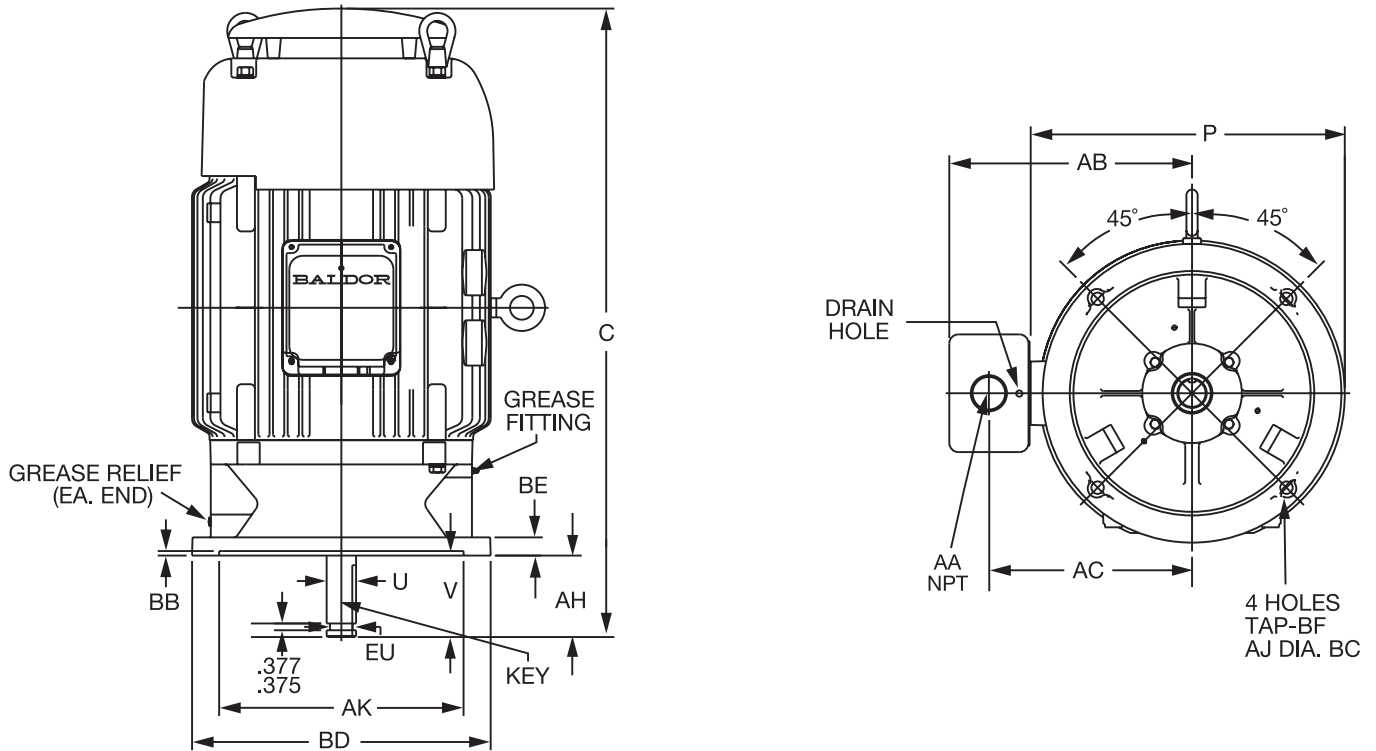

NEMA frame	Key	P	U	V min	AA NPT	AB	AC	AH	AJ	AK	BB	BD	BE	Tap* BF	EU
182HP	6,35	345,44	28,58	76,20	25,40	199,39	210,57	69,85	231,65	209,55	6,35	250,95	17,53	11,18	22,23
184HP	(0.25)	(13.6)	(1.125)	(3)	(1)	(7.85)	(8.29)	(2.75)	(9.12)	(8.25)	(0.25)	(9.88)	(0.69)	(0.44)	(0.875)
213HP	6,35	308,10	28,58	76,20	38,10	220,47	180,59	69,85	231,65	209,55	6,35	250,95	17,53	11,18	22,23
215HP	(0.25)	(12.13)	(1.125)	(3)	(1.5)	(8.68)	(7.11)	(2.75)	(9.12)	(8.25)	(0.25)	(9.88)	(0.69)	(0.44)	(0.875)
254HP	6,35	328,68	28,58	76,20	38,10	257,30	210,57	69,85	231,65	209,55	6,35	250,70	17,53	11,18	22,23
256HP	(0.25)	(12.94)	(1.125)	(3)	(1.5)	(10.13)	(8.29)	(2.75)	(9.12)	(8.25)	(0.25)	(9.87)	(0.69)	(0.44)	(0.875)
284HP	6,35	395,22	28,58	76,20	50,80	319,28	261,87	69,85	231,65	209,55	6,35	250,70	17,53	11,18	22,23
286HP	(0.25)	(15.56)	(1.125)	(3)	(2)	(12.57)	(10.31)	(2.75)	(9.12)	(8.25)	(0.25)	(9.87)	(0.69)	(0.44)	(0.875)
324HP	9,65	440,69	41,28	120,65	50,80	342,14	283,46	114,30	374,65	342,90	6,35	419,10	25,40	11,18	31,75
326HP	(0.38)	(17.35)	(1.625)	(4.75)	(2)	(13.47)	(11.16)	(4.5)	(14.75)	(13.5)	(0.25)	(16.5)	(1)	(0.44)	(1.25)
364HP	9,53	514,35	41,28	114,30	76,20	457,20	350,77	114,30	374,65	342,90	6,35	419,10	22,35	17,53	31,75
365HP	(0.375)	(20.25)	(1.625)	(4.5)	(3)	(18)	(13.81)	(4.5)	(14.75)	(13.5)	(0.25)	(16.5)	(0.88)	(0.69)	(1.25)

Note: Dimensions are in mm (in). Dimension for reference only. Contact your ABB regional support office for the detailed dimension drawing for your specific catalog number.
 * Tap size specified are SAE thread size (no metric equivalent).
 Please refer to keyway detail at the end of the AC section.

NEMA Super-E[®] premium efficient motors

Dimension drawings

Close-coupled pump motors – TEFC
 JM mount
 NEMA 143JM - 326JM

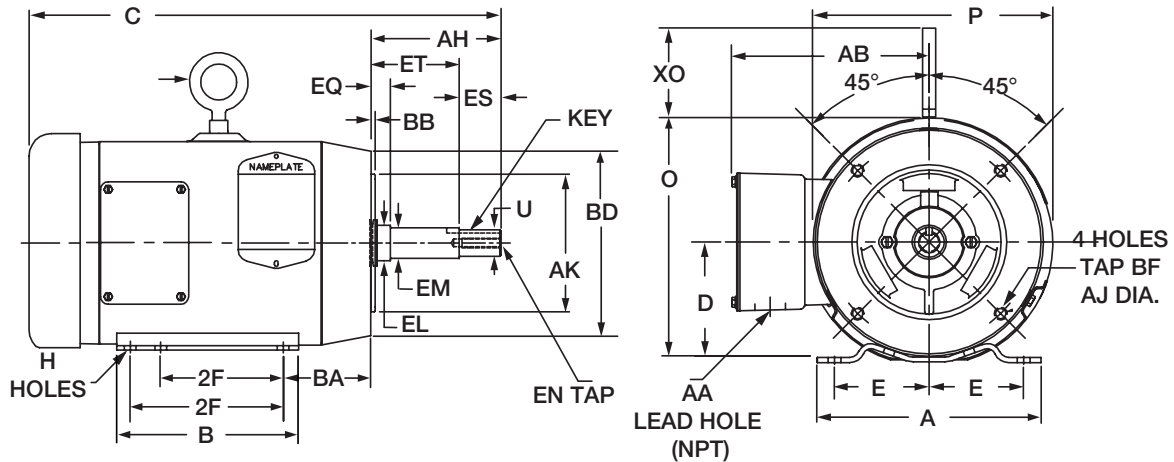

NEMA frame	A	B	D	E	2F	H	Key	O	P	U	AA	AB	AH	AJ	Tap* BF	AK	BA	BB	BD	XO
Steel band construction																				
143JM	165,10 (6.5)	150,88 (5.94)	88,90 (3.5)	69,85 (2.75)	101,60 (4)	8,64 (0.34)	4,83 (0.19)	172,97 (6.81)	168,40 (6.63)	22,23 (0.875)	12,70 (0.5)	145,54 (5.73)	107,95 (4.25)	149,35 (5.88)	3/8-16	114,30 (4.5)	73,15 (2.88)	3,05 (0.12)	165,10 (6.5)	—
145JM	165,10 (6.5)	150,88 (5.94)	88,90 (3.5)	69,85 (2.75)	127,00 (5)	8,64 (0.34)	4,83 (0.19)	172,97 (6.81)	168,40 (6.63)	22,23 (0.875)	12,70 (0.5)	145,54 (5.73)	107,95 (4.25)	149,35 (5.88)	3/8-16	114,30 (4.5)	73,15 (2.88)	3,05 (0.12)	165,10 (6.5)	—
182JM	219,20 (8.63)	165,10 (6.5)	114,30 (4.5)	95,25 (3.75)	114,30 (4.5)	10,41 (0.41)	4,83 (0.19)	214,38 (8.44)	200,15 (7.88)	22,23 (0.875)	19,05 (0.75)	174,24 (6.86)	107,95 (4.25)	149,35 (5.88)	3/8-16	114,30 (4.5)	88,90 (3.5)	3,05 (0.12)	165,10 (6.5)	60,96 (2.4)
184JM	219,20 (8.63)	165,10 (6.5)	114,30 (4.5)	95,25 (3.75)	139,70 (5.5)	10,41 (0.41)	4,83 (0.19)	214,38 (8.44)	200,15 (7.88)	22,23 (0.875)	19,05 (0.75)	174,24 (6.86)	107,95 (4.25)	149,35 (5.88)	3/8-16	114,30 (4.5)	88,90 (3.5)	3,05 (0.12)	165,10 (6.5)	60,96 (2.4)
213JM	241,30 (9.5)	203,20 (8)	133,35 (5.25)	107,95 (4.25)	139,70 (5.5)	10,41 (0.41)	4,83 (0.19)	254,76 (10.03)	242,82 (9.56)	22,23 (0.875)	35,05 (1.38)	204,22 (8.04)	107,95 (4.25)	184,15 (7.25)	1/2-13	215,90 (8.5)	114,30 (4.5)	6,35 (0.25)	230,12 (9.06)	60,96 (2.4)
215JM	241,30 (9.5)	203,20 (8)	133,35 (5.25)	107,95 (4.25)	177,80 (7)	10,41 (0.41)	4,83 (0.19)	254,76 (10.03)	242,82 (9.56)	22,23 (0.875)	35,05 (1.38)	204,22 (8.04)	107,95 (4.25)	184,15 (7.25)	1/2-13	215,90 (8.5)	114,30 (4.5)	6,35 (0.25)	230,12 (9.06)	60,96 (2.4)
Cast iron																				
254JM	292,10 (11.5)	292,10 (11.5)	158,75 (6.25)	127,00 (5)	209,55 (8.25)	13,46 (0.53)	6,35 (0.25)	327,15 (12.88)	328,68 (12.94)	31,75 (1.25)	35,05 (1.38)	255,02 (10.04)	133,35 (5.25)	184,15 (7.25)	1/2-13	215,90 (8.5)	120,65 (4.75)	6,35 (0.25)	230,89 (9.09)	69,09 (2.72)
256JM	292,10 (11.5)	292,10 (11.5)	158,75 (6.25)	127,00 (5)	254,00 (10)	13,46 (0.53)	6,35 (0.25)	327,15 (12.88)	328,68 (12.94)	31,75 (1.25)	35,05 (1.38)	255,02 (10.04)	133,35 (5.25)	184,15 (7.25)	1/2-13	215,90 (8.5)	120,65 (4.75)	6,35 (0.25)	230,89 (9.09)	69,09 (2.72)
284JM	323,85 (12.75)	326,14 (12.84)	177,80 (7)	139,70 (5.5)	241,30 (9.5)	13,46 (0.53)	6,35 (0.25)	366,78 (14.44)	388,37 (15.29)	31,75 (1.25)	50,80 (2)	332,99 (13.11)	133,35 (5.25)	279,40 (11)	5/8-11	317,50 (12.5)	120,65 (4.75)	6,35 (0.25)	331,47 (13.05)	69,09 (2.72)
286JM	323,85 (12.75)	326,14 (12.84)	177,80 (7)	139,70 (5.5)	279,40 (11)	13,46 (0.53)	6,35 (0.25)	366,78 (14.44)	388,37 (15.29)	31,75 (1.25)	50,80 (2)	332,99 (13.11)	133,35 (5.25)	279,40 (11)	5/8-11	317,50 (12.5)	120,65 (4.75)	6,35 (0.25)	331,47 (13.05)	69,09 (2.72)
324JM	368,30 (14.5)	355,60 (14)	203,20 (8)	158,75 (6.25)	266,70 (10.5)	16,76 (0.66)	6,35 (0.25)	412,75 (16.25)	453,39 (17.85)	31,75 (1.25)	63,50 (2.5)	371,09 (14.61)	133,35 (5.25)	279,40 (11)	5/8-11	317,50 (12.5)	133,35 (5.25)	6,35 (0.25)	340,36 (13.4)	81,79 (3.22)
326JM	368,30 (14.5)	355,60 (14)	203,20 (8)	158,75 (6.25)	304,80 (12)	16,76 (0.66)	6,35 (0.25)	412,75 (16.25)	453,39 (17.85)	31,75 (1.25)	63,50 (2.5)	371,09 (14.61)	133,35 (5.25)	279,40 (11)	5/8-11	317,50 (12.5)	133,35 (5.25)	6,35 (0.25)	340,36 (13.4)	81,79 (3.22)

NEMA frame	EL	EM	EN *	EQ	ES	ET
Steel band construction						
143JM	29,21 (1.15)	25,40 (1)	0.38-16 x 0.88	15,88 (0.625)	35,05 (1.38)	73,03 (2.875)
145JM	29,21 (1.15)	25,40 (1)	0.38-16 x 0.88	15,88 (0.625)	35,05 (1.38)	73,03 (2.875)
182JM	31,75 (1.25)	25,40 (1)	0.38-16 x 0.88	15,88 (0.625)	35,05 (1.38)	73,03 (2.875)
184JM	31,75 (1.25)	25,40 (1)	0.38-16 x 0.88	15,88 (0.625)	35,05 (1.38)	73,03 (2.875)
213JM	31,75 (1.25)	25,40 (1)	0.38-16 x 0.88	15,88 (0.625)	35,05 (1.38)	73,03 (2.875)
215JM	31,75 (1.25)	25,40 (1)	0.38-16 x 0.88	15,88 (0.625)	35,05 (1.38)	73,03 (2.875)
Cast Iron						
254JM	44,45 (1.75)	35,05 (1.38)	0.50-13x1.12	15,88 (0.625)	57,15 (2.25)	76,20 (3)
256JM	44,45 (1.75)	35,05 (1.38)	0.50-13x1.12	15,88 (0.625)	57,15 (2.25)	76,20 (3)
284JM	44,45 (1.75)	35,05 (1.38)	0.50-13x1.12	15,88 (0.625)	57,15 (2.25)	76,20 (3)
286JM	44,45 (1.75)	35,05 (1.38)	0.50-13x1.12	15,88 (0.625)	57,15 (2.25)	76,20 (3)
324JM	44,45 (1.75)	35,05 (1.38)	0.50-13x1.25	15,88 (0.625)	57,15 (2.25)	76,20 (3)
326JM	44,45 (1.75)	35,05 (1.38)	0.50-13x1.25	15,88 (0.625)	57,15 (2.25)	76,20 (3)

Note: Dimensions are in mm (in). Dimension for reference only. Contact your ABB regional support office for the detailed dimension drawing for your specific catalog number.
 * Tap size specified are SAE thread size (no metric equivalent).

NEMA Super-E[®] premium efficient motors

Dimension drawings

Close-coupled pump motors – TEFC
 JP mount
 NEMA 215JP - 326JP

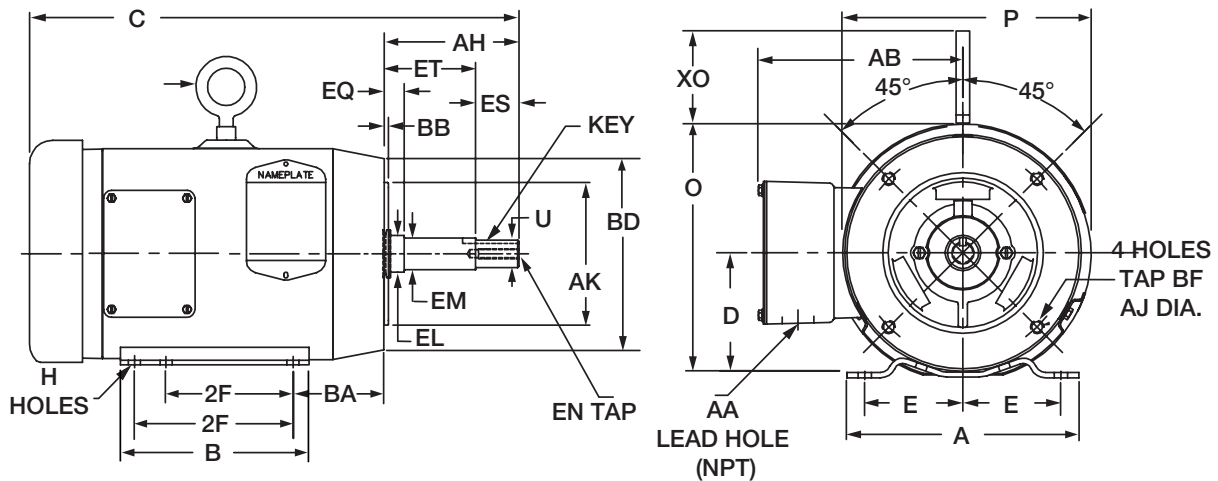

NEMA frame	A	B	D	E	2F	H	Key	O	P	U	AA	AB	AH	AJ	Tap BF *	AK	BA	BB	BD	XO
Steel band construction																				
215JP	241,30 (9.5)	203,20 (8)	133,35 (5.25)	107,95 (4.25)	177,80 (7)	10,41 (0.41)	4,83 (0.19)	254,76 (10.03)	242,82 (9.56)	22,23 (0.875)	35,05 (1.38)	204,22 (8.04)	206,38 (8.125)	184,15 (7.25)	1/2-13	215,90 (8.5)	114,30 (4.5)	6,35 (0.25)	230,12 (9.06)	60,96 (2.4)
Cast iron																				
254JP	292,10 (11.5)	292,10 (11.5)	158,75 (6.25)	127,00 (5)	209,55 (8.25)	13,46 (0.53)	6,35 (0.25)	327,15 (12.88)	328,68 (12.94)	31,75 (1.25)	35,05 (1.38)	255,02 (10.04)	206,38 (8.125)	184,15 (7.25)	1/2-13	215,90 (8.5)	120,65 (4.75)	6,35 (0.25)	230,89 (9.09)	69,09 (2.72)
256JP	292,10 (11.5)	292,10 (11.5)	158,75 (6.25)	127,00 (5)	254,00 (10)	13,46 (0.53)	6,35 (0.25)	327,15 (12.88)	328,68 (12.94)	31,75 (1.25)	35,05 (1.38)	255,02 (10.04)	206,38 (8.125)	184,15 (7.25)	1/2-13	215,90 (8.5)	120,65 (4.75)	6,35 (0.25)	230,89 (9.09)	69,09 (2.72)
284JP	323,85 (12.75)	326,14 (12.84)	177,80 (7)	139,70 (5.5)	241,30 (9.5)	13,46 (0.53)	6,35 (0.25)	366,78 (14.44)	388,37 (15.29)	31,75 (1.25)	50,80 (2)	332,99 (13.11)	206,38 (8.125)	279,40 (11)	5/8-11	317,50 (12.5)	120,65 (4.75)	6,35 (0.25)	331,47 (13.05)	69,09 (2.72)
286JP	323,85 (12.75)	326,14 (12.84)	177,80 (7)	139,70 (5.5)	279,40 (11)	13,46 (0.53)	6,35 (0.25)	366,78 (14.44)	388,37 (15.29)	31,75 (1.25)	50,80 (2)	332,99 (13.11)	206,38 (8.125)	279,40 (11)	5/8-11	317,50 (12.5)	120,65 (4.75)	6,35 (0.25)	331,47 (13.05)	69,09 (2.72)
324JP	368,30 (14.5)	355,60 (14)	203,20 (8)	158,75 (6.25)	266,70 (10.5)	16,76 (0.66)	6,35 (0.25)	412,75 (16.25)	453,39 (17.85)	31,75 (1.25)	63,50 (2.5)	371,09 (14.61)	206,38 (8.125)	279,40 (11)	5/8-11	317,50 (12.5)	133,35 (5.25)	6,35 (0.25)	340,36 (13.4)	81,79 (3.22)
326JP	368,30 (14.5)	355,60 (14)	203,20 (8)	158,75 (6.25)	304,80 (12)	16,76 (0.66)	6,35 (0.25)	412,75 (16.25)	453,39 (17.85)	31,75 (1.25)	63,50 (2.5)	371,09 (14.61)	206,38 (8.125)	279,40 (11)	5/8-11	317,50 (12.5)	133,35 (5.25)	6,35 (0.25)	340,36 (13.4)	81,79 (3.22)

NEMA frame	EL	EM	EN *	EQ	ES	ET
Steel band construction						
215JP	44,45 (1.75)	35,05 (1.38)	0.50-13x1.12	60,33 (2.375)	57,15 (2.25)	149,23 (5.875)
Cast iron						
254JP	44,45 (1.75)	35,05 (1.38)	0.50-13x1.12	60,33 (2.375)	57,15 (2.25)	149,23 (5.875)
256JP	44,45 (1.75)	35,05 (1.38)	0.50-13x1.12	60,33 (2.375)	57,15 (2.25)	149,23 (5.875)
284JP	44,45 (1.75)	35,05 (1.38)	0.50-13x1.12	60,33 (2.375)	57,15 (2.25)	149,23 (5.875)
286JP	44,45 (1.75)	35,05 (1.38)	0.50-13x1.12	60,33 (2.375)	57,15 (2.25)	149,23 (5.875)
324JP	44,45 (1.75)	35,05 (1.38)	0.50-13x1.25	60,33 (2.375)	57,15 (2.25)	149,23 (5.875)
326JP	44,45 (1.75)	35,05 (1.38)	0.50-13x1.25	60,33 (2.375)	57,15 (2.25)	149,23 (5.875)

Note: Dimensions are in mm (in).
 Dimension for reference only.
 Contact your ABB regional support office for the detailed dimension drawing for your specific catalog number.
 * Tap size specified are SAE tread size (no metric equivalent).

NEMA Super-E[®] premium efficient motors

Dimension drawings

Close-coupled pump motors – open drip proof
JM mount
NEMA 143JM - 326JM

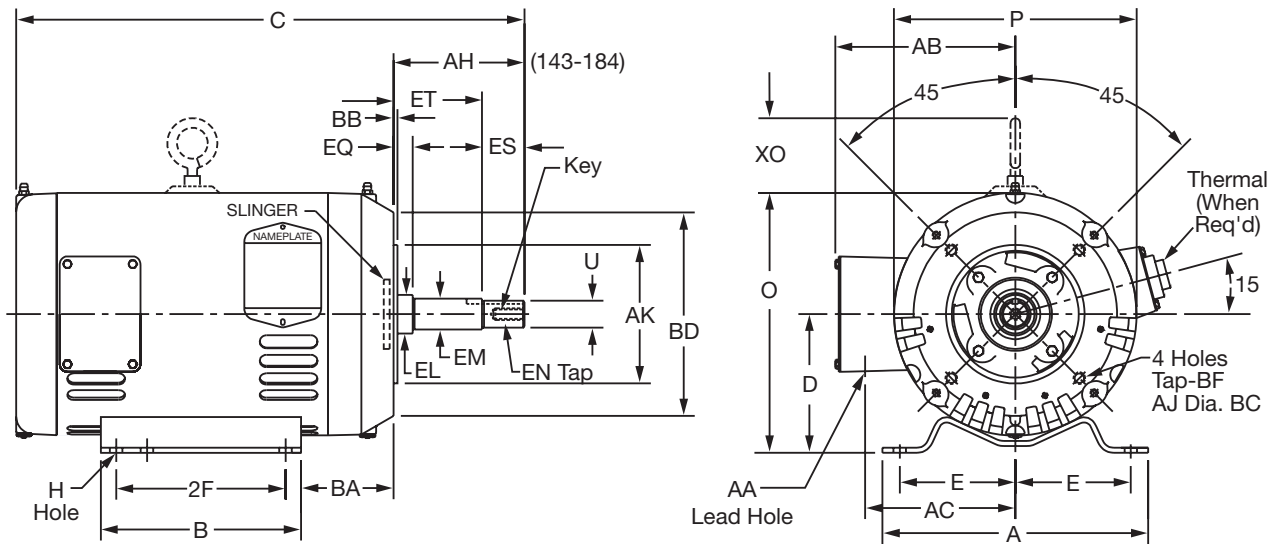

NEMA frame	A	B	D	E	2F	H	Key	O	P	U	AA	AB	AC	AH	AJ	AK	BB	BD	Tap * BF	BA
143JM	165,10	150,88	88,90	69,85	101,60 (4)	8,64	4,83	171,96	168,15	22,23	22,35	142,49	115,82	108,71	149,35	114,30	3,30	165,35	0.38-16	73,15
145JM	(6.5)	(5.94)	(3.5)	(2.75)	127,00 (5)	(0.34)	(0.19)	(6.77)	(6.62)	(0.875)	(0.88)	(5.61)	(4.56)	(4.28)	(5.88)	(4.5)	(0.13)	(6.51)		(2.88)
182JM	219,20	165,10	114,30	95,25	114,30 (4.5)	10,41	4,83	214,38	200,15	22,23	27,69	171,20	144,78	107,95	149,35	114,30	3,30	167,89	0.38-16	88,90
184JM	(8.63)	(6.5)	(4.5)	(3.75)	139,70 (5.5)	(0.41)	(0.19)	(8.44)	(7.88)	(0.875)	(1.09)	(6.74)	(5.7)	(4.25)	(5.88)	(4.5)	(0.13)	(6.61)		(3.5)
213JM	241,30	203,20	133,35	107,95	139,70 (5.5)	10,41	4,78	254,76	243,08	22,23	35,05	201,17	170,69	107,95	184,15	215,90	6,35	230,38	0.50-13	107,95
215JM	(9.5)	(8)	(5.25)	(4.25)	177,80 (7)	(0.41)	(0.188)	(10.03)	(9.57)	(0.875)	(1.38)	(7.92)	(6.72)	(4.25)	(7.25)	(8.5)	(0.25)	(9.07)		(4.25)
254JM	285,75	285,75	158,75	127,00	209,55 (8.25)	13,46	6,35	304,80	292,10	31,75	35,05	241,05	195,33	133,35	184,15	215,90	6,35	240,03	0.50-13	120,65
256JM	(11.25)	(11.25)	(6.25)	(5)	254,00 (10)	(0.53)	(0.25)	(12)	(11.5)	(1.25)	(1.38)	(9.49)	(7.69)	(5.25)	(7.25)	(8.5)	(0.25)	(9.45)		(4.75)
284JM	311,15	311,15	177,80	139,70	241,30 (9.5)	13,46	6,35	346,20	336,55	31,75	50,80	310,13	246,89	133,35	279,40	317,50	6,35	330,96	0.62-11	120,65
286JM	(12.25)	(12.25)	(7)	(5.5)	279,40 (11)	(0.53)	(0.25)	(13.63)	(13.25)	(1.25)	(2)	(12.21)	(9.72)	(5.25)	(11)	(12.5)	(0.25)	(13.03)		(4.75)
324JM	356,62	342,90	203,20	158,75	266,70 (10.5)	16,76	6,35	395,99	385,06	34,93	63,50	335,28	272,03	133,35	279,40	317,50	6,35	338,07	0.62-11	133,35
326JM	(14.04)	(13.5)	(8)	(6.25)	304,80 (12)	(0.66)	(0.25)	(15.59)	(15.16)	(1.375)	(2.5)	(13.2)	(10.71)	(5.25)	(11)	(12.5)	(0.25)	(13.31)		(5.25)

NEMA frame	EL	EM	EN *	EQ	ES	ET
143JM						
145JM	39,62 (1.56)	25,40 (1)	0.38-16x0.88	16,26 (0.64)	35,31 (1.39)	73,41 (2.89)
182JM						
184JM	31,75 (1.25)	25,40 (1)	0.38-16x0.88	16,26 (0.64)	35,31 (1.39)	73,41 (2.89)
213JM						
215JM	31,75 (1.25)	25,40 (1)	0.38-16x0.88	16,26 (0.64)	34,54 (1.36)	73,41 (2.89)
254JM						
256JM	44,45 (1.75)	34,93 (1.375)	0.50-13x1.25	15,88 (0.625)	57,15 (2.25)	76,20 (3)
284JM						
286JM	44,45 (1.75)	34,93 (1.375)	0.50-13x1.25	15,88 (0.625)	57,15 (2.25)	76,20 (3)
324JM						
326JM	44,45 (1.75)	34,93 (1.375)	0.50-13x1.25	15,88 (0.625)	57,15 (2.25)	76,20 (3)

Note: Dimensions are in mm (in).
Dimension for reference only.

Contact your ABB regional support office for the detailed dimension drawing for your specific catalog number.

* Tap size specified are SAE thread size (no metric equivalent).

NEMA Super-E[®] premium efficient motors

Dimension drawings

Close-coupled pump motors – open drip proof
 JP mount
 NEMA 213JP - 326JP

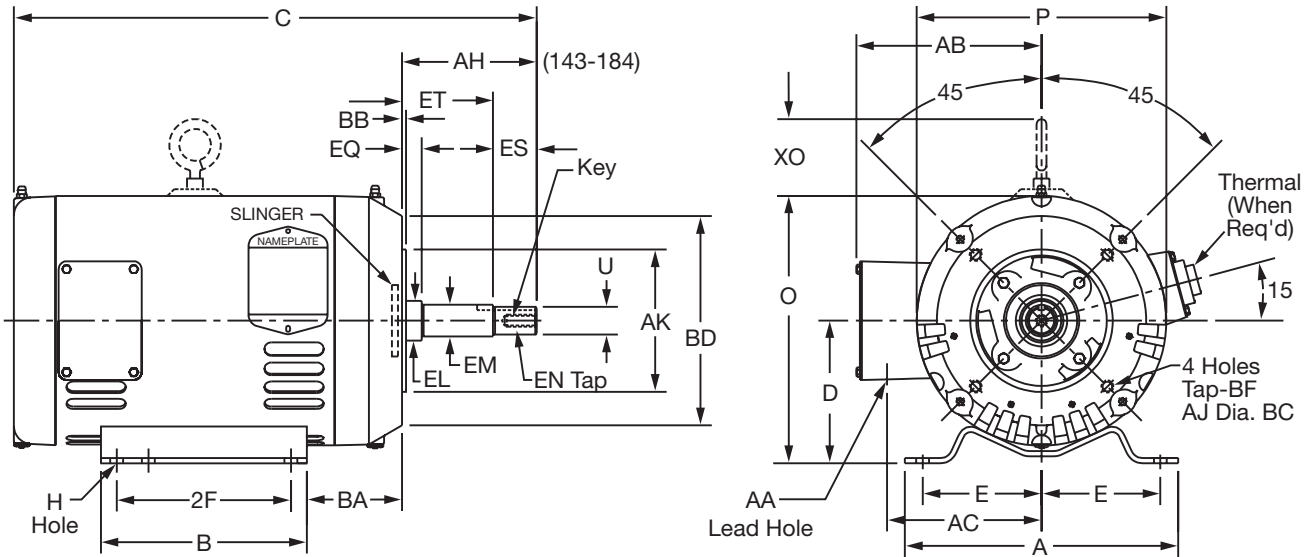

NEMA frame	A	B	D	E	2F	H	Key	O	P	U	AA	AB	AC	AH	AJ	AK	BB	BD	Tap * BF	BA
213JP	241,30 (9.5)	203,20 (8)	133,35 (5.25)	107,95 (4.25)	139,70 (5.5)	10,41 (0.41)	4,78 (0.188)	254,76 (10.03)	395,99 (15.59)	22,23 (0.875)	35,05 (1.38)	201,17 (7.92)	170,69 (6.72)	206,38 (8.125)	184,15 (7.25)	215,90 (8.5)	6,35 (0.25)	230,38 (9.07)	0.50-13	107,95 (4.25)
215JP	241,30 (9.5)	203,20 (8)	133,35 (5.25)	107,95 (4.25)	177,80 (7)	10,41 (0.41)	4,78 (0.188)	254,76 (10.03)	395,99 (15.59)	22,23 (0.875)	35,05 (1.38)	201,17 (7.92)	170,69 (6.72)	206,38 (8.125)	184,15 (7.25)	215,90 (8.5)	6,35 (0.25)	230,38 (9.07)	0.50-13	107,95 (4.25)
254JP	285,75 (11.25)	285,75 (11.25)	158,75 (6.25)	127,00 (5)	209,55 (8.25)	13,46 (0.53)	6,35 (0.25)	304,80 (12)	395,99 (15.59)	31,75 (1.25)	35,05 (1.38)	241,05 (9.49)	195,33 (7.69)	206,38 (8.125)	184,15 (7.25)	215,90 (8.5)	6,35 (0.25)	240,03 (9.45)	0.50-13	120,65 (4.75)
256JP	285,75 (11.25)	285,75 (11.25)	158,75 (6.25)	127,00 (5)	254,00 (10)	13,46 (0.53)	6,35 (0.25)	304,80 (12)	395,99 (15.59)	31,75 (1.25)	35,05 (1.38)	241,05 (9.49)	195,33 (7.69)	206,38 (8.125)	184,15 (7.25)	215,90 (8.5)	6,35 (0.25)	240,03 (9.45)	0.50-13	120,65 (4.75)
284JP	311,15 (12.25)	311,15 (12.25)	177,80 (7)	139,70 (5.5)	241,30 (9.5)	13,46 (0.53)	6,35 (0.25)	346,20 (13.63)	336,55 (13.25)	31,75 (1.25)	50,80 (2)	310,13 (12.21)	246,89 (9.72)	206,38 (8.125)	279,40 (11)	317,50 (12.5)	6,35 (0.25)	330,96 (13.03)	0.62-11	120,65 (4.75)
286JP	311,15 (12.25)	311,15 (12.25)	177,80 (7)	139,70 (5.5)	279,40 (11)	13,46 (0.53)	6,35 (0.25)	346,20 (13.63)	336,55 (13.25)	31,75 (1.25)	50,80 (2)	310,13 (12.21)	246,89 (9.72)	206,38 (8.125)	279,40 (11)	317,50 (12.5)	6,35 (0.25)	330,96 (13.03)	0.62-11	120,65 (4.75)
324JP	356,62 (14.04)	342,90 (13.5)	203,20 (8)	158,75 (6.25)	266,70 (10.5)	16,76 (0.66)	6,35 (0.25)	395,99 (15.59)	385,06 (15.16)	34,93 (1.375)	63,50 (2.5)	335,28 (13.2)	272,03 (10.71)	206,38 (8.125)	279,40 (11)	317,50 (12.5)	6,35 (0.25)	338,07 (13.31)	0.62-11	133,35 (5.25)
326JP	356,62 (14.04)	342,90 (13.5)	203,20 (8)	158,75 (6.25)	304,80 (12)	16,76 (0.66)	6,35 (0.25)	395,99 (15.59)	385,06 (15.16)	34,93 (1.375)	63,50 (2.5)	335,28 (13.2)	272,03 (10.71)	206,38 (8.125)	279,40 (11)	317,50 (12.5)	6,35 (0.25)	338,07 (13.31)	0.62-11	133,35 (5.25)

NEMA frame	EL	EM	EN	EQ	ES	ET
213JP	44,45 (1.75)	35,05 (1.38)	0.50-13x1.12	60,33 (2.375)	57,15 (2.25)	149,23 (5.875)
215JP	44,45 (1.75)	35,05 (1.38)	0.50-13x1.12	60,33 (2.375)	57,15 (2.25)	149,23 (5.875)
254JP	44,45 (1.75)	35,05 (1.38)	0.50-13x1.12	60,33 (2.375)	57,15 (2.25)	149,23 (5.875)
256JP	44,45 (1.75)	35,05 (1.38)	0.50-13x1.12	60,33 (2.375)	57,15 (2.25)	149,23 (5.875)
284JP	44,45 (1.75)	35,05 (1.38)	0.50-13x1.12	60,33 (2.375)	57,15 (2.25)	149,23 (5.875)
286JP	44,45 (1.75)	35,05 (1.38)	0.50-13x1.12	60,33 (2.375)	57,15 (2.25)	149,23 (5.875)
324JP	44,45 (1.75)	35,05 (1.38)	0.50-13x1.12	60,33 (2.375)	57,15 (2.25)	149,23 (5.875)
326JP	44,45 (1.75)	35,05 (1.38)	0.50-13x1.12	60,33 (2.375)	57,15 (2.25)	149,23 (5.875)

Note: Dimensions are in mm (in).
 Dimension for reference only.
 Contact your ABB regional support office for the detailed dimension drawing for your specific catalog number.
 * Tap size specified are SAE tread size (no metric equivalent).

NEMA Super-E® premium efficient motors

Dimension drawings

Chiller/cooling tower – TEAO
 Foot mounted
 NEMA 182T - 405T

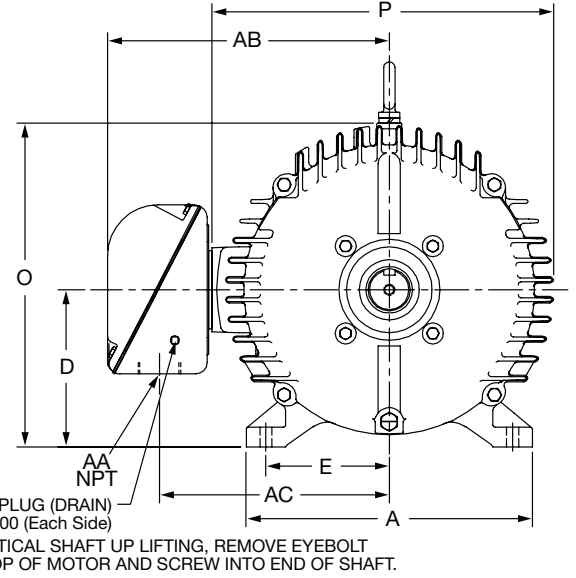
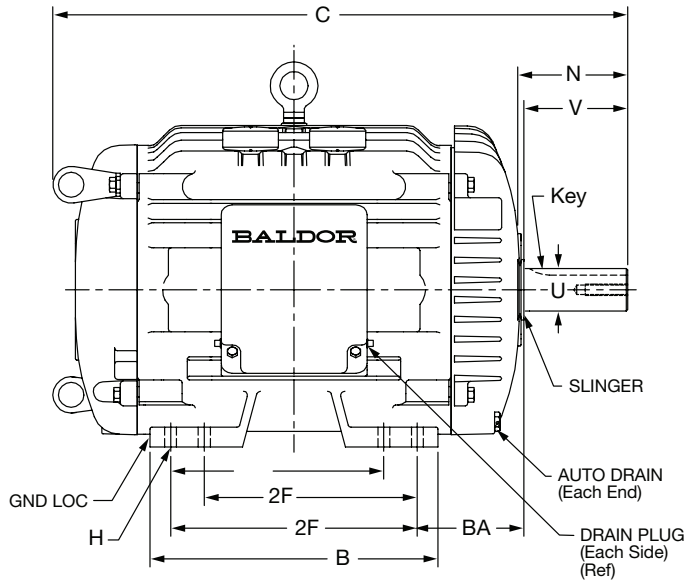

Frame size	A	B	D	E	2F	H	Key	N	O	P	U	V	AA	AB	AC	BA
182T	218,95	165,10	114,30	95,25	114,30 (4,5)	10,41	6,35	71,37	234,44	240,28	28,58	69,85	19,05	180,85	146,05	69,85
184T	(8.62)	(6.5)	(4.5)	(3.75)	139,70 (5,5)	(0,41)	(0,25)	(2,81)	(9,23)	(9,46)	(1,125)	(2,75)	(0,75)	(7,12)	(5,75)	(2,75)
213T	244,35	206,25	133,35	107,95	139,70 (5,5)	10,41	7,87	98,55	279,15	292,10	34,93	85,85	25,40	234,19	188,72	88,90
215T	(9.62)	(8.12)	(5.25)	(4.25)	177,80 (7)	(0,41)	(0,31)	(3,88)	(10,99)	(11,5)	(1,375)	(3,38)	(1)	(9,22)	(7,43)	(3,5)
254T	292,10	292,10	158,75	127,00	209,55 (8,25)	13,46	9,65	109,73	327,15	328,68	41,28	101,60	31,75	256,54	211,33	107,95
256T	(11.5)	(11.5)	(6.25)	(5)	254,00 (10)	(0,53)	(0,38)	(4,32)	(12,88)	(12,94)	(1,625)	(4)	(1,25)	(10,1)	(8,32)	(4,25)
284T	324,10	326,14	177,80	139,70	241,30 (9,5)	13,46	12,70	124,71	366,78	387,10	47,63	117,60	38,10	319,02	260,35	120,65
286T	(12.76)	(12.84)	(7)	(5,5)	279,40 (11)	(0,53)	(0,5)	(4,91)	(14,44)	(15,24)	(1,875)	(4,63)	(1,5)	(12,56)	(10,25)	(4,75)
324T	368,30	355,60	203,20	158,75	266,70 (10,5)	16,76	12,70	143,00	412,75	448,31	53,98	133,35	50,80	355,60	298,45	133,35
326T	(14.5)	(14)	(8)	(6,25)	304,80 (12)	(0,66)	(0,5)	(5,63)	(16,25)	(17,65)	(2,125)	(5,25)	(2)	(14)	(11,75)	(5,25)
364T	419,10	368,30	228,60	177,80	285,75 (11,25)	16,76	15,88	155,45	466,85	479,04	60,33	149,35	63,50	365,76	307,09	149,35
365T	(16.5)	(14.5)	(9)	(7)	311,15 (12,25)	(0,66)	(0,625)	(6,12)	(18,38)	(18,86)	(2,375)	(5,88)	(2,5)	(14,4)	(12,09)	(5,88)
404T	479,55	422,40	254,00	203,20	311,15 (12,25)	20,57	19,05	193,55	515,87	537,72	73,03	184,15	76,20	457,45	369,06	168,15
405T	(18.88)	(16.63)	(10)	(8)	349,25 (13,75)	(0,81)	(0,75)	(7,62)	(20,31)	(21,17)	(2,875)	(7,25)	(3)	(18,01)	(14,53)	(6,62)

Note: Dimensions are in mm (in).
 Dimension for reference only.

Contact your ABB regional support office for the detailed dimension drawing for your specific catalog number.

NEMA Super-E[®] premium efficient motors

Dimension drawings

Unit handling motors
C-face foot mounted
NEMA 56C - 145TCY

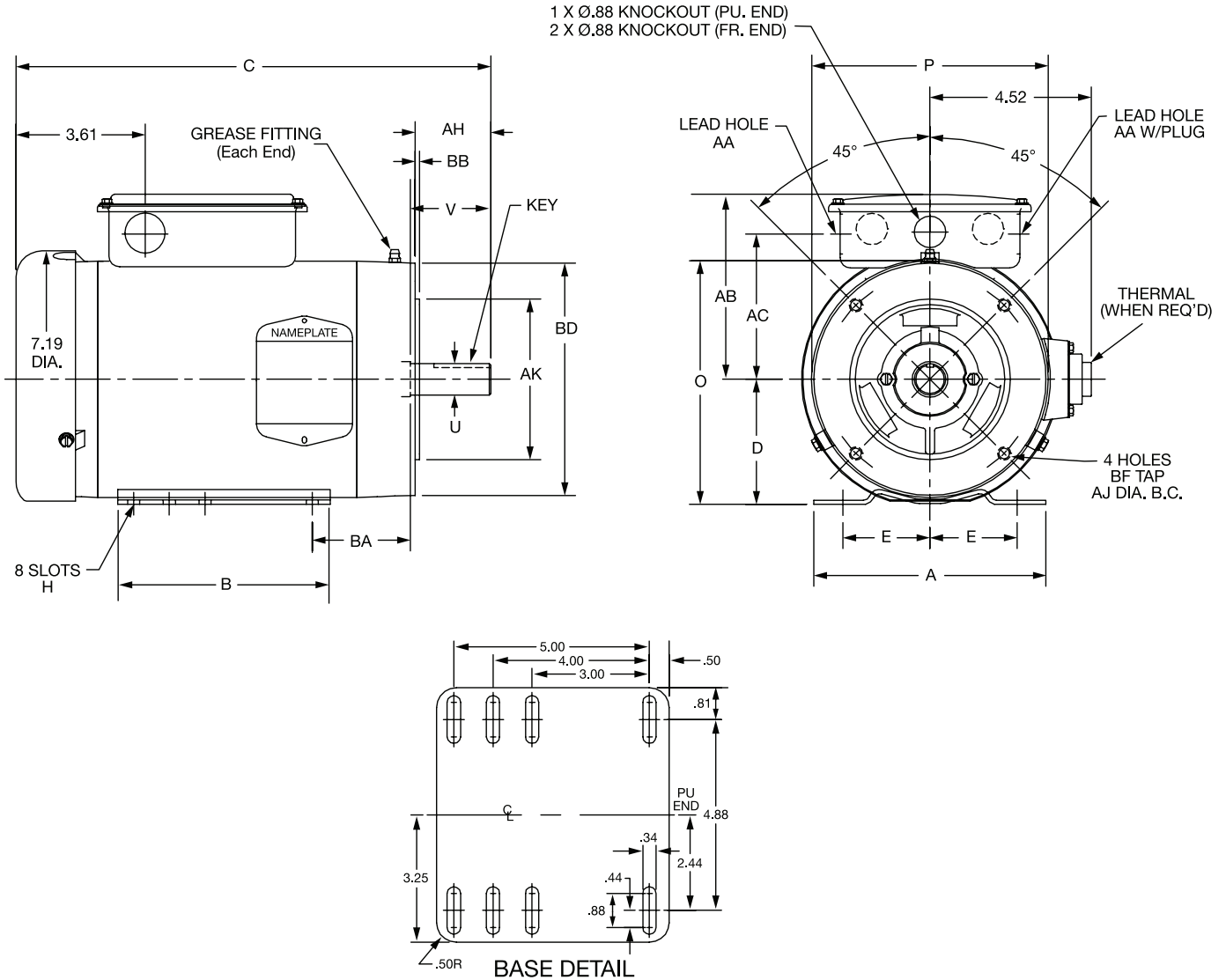

NEMA frame	A	B	D	E	H	O	P	U	V	KEY	AA	AB	AC	AH	AJ	TAP BF*	AK	BA	BB	BD
56C	165.10 (6.50)	165.10 (6.50)	88.90 (3.50)	61.98 (2.44)	10.16 (0.41)	172.97 (6.81)	168.15 (6.62)	15.88 (0.63)	47.75 (1.88)	4.83 (0.19)	28.45 (1.12)	131.57 (5.18)	103.38 (4.07)	52.32 (2.06)	149.35 (5.88)	3/8-16	114.30 (4.50)	69.85 (2.75)	3.30 (0.13)	165.35 (6.51)
143TC/TCY	165.10 (6.50)	150.88 (5.94)	88.90 (3.50)	61.98 (2.44)	8.64 (0.34)	173.23 (6.82)	168.15 (6.62)	22.23 (0.88)	57.15 (2.25)	4.83 (0.19)	28.45 (1.12)	131.57 (5.18)	103.38 (4.07)	52.32 (2.06)	149.35 (5.88)	3/8-16	114.30 (4.50)	69.85 (2.75)	3.30 (0.13)	165.35 (6.51)
145TC/TCY	165.10 (6.50)	150.88 (5.94)	88.90 (3.50)	61.98 (2.44)	8.64 (0.34)	173.23 (6.82)	168.15 (6.62)	22.23 (0.88)	57.15 (2.25)	4.83 (0.19)	28.45 (1.12)	131.57 (5.18)	103.38 (4.07)	52.32 (2.06)	149.35 (5.88)	3/8-16	114.30 (4.50)	69.85 (2.75)	3.30 (0.13)	165.35 (6.51)

Note: Dimensions are in mm (in).

* Tap size specified are SAE thread size (no metric equivalent)

Dimension for reference only.

Contact your ABB regional support office for the detailed dimension drawing for your specific catalog number.

NEMA Super-E[®] premium efficient motors

Dimension drawings

Unit handling motors
C-face foot mounted
NEMA 182TC - 215TC

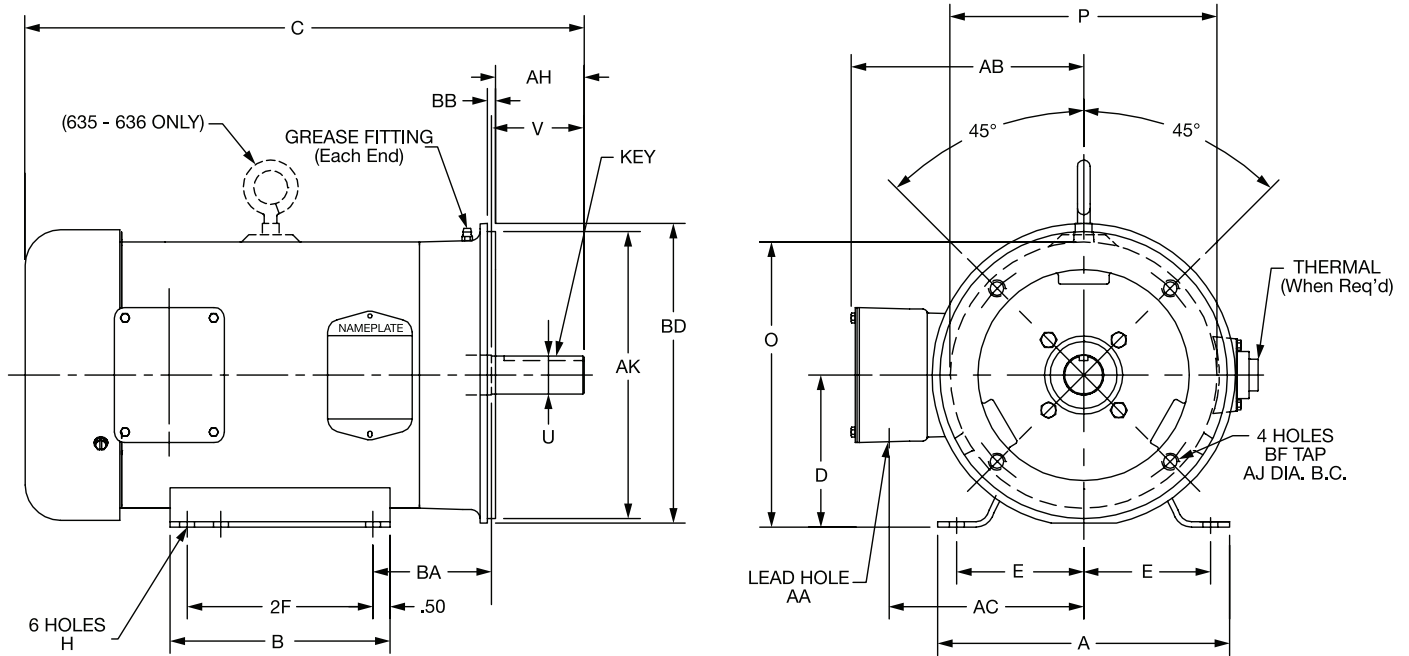

NEMA frame	A	B	D	E	2F	H	O	P	U	V	KEY	AA	AB	AC	AH	AJ	TAP BF*	AK	BA	BB	BD
182TC	219.20	165.10	114.30	95.25	114.30 (4.50)	10.41	214.38	200.15	28.58	69.85	6.35	27.69	174.50	146.30	66.55	184.15	1/2-13	215.90	88.90	6.35	225.04
184TC	(8.63)	(6.50)	(4.50)	(3.75)	139.70 (5.50)	(0.41)	(8.44)	(7.88)	(1.13)	(2.75)	(0.25)	(1.09)	(6.87)	(5.76)	(2.62)	(7.25)		(8.50)	(3.50)	(0.25)	(8.86)
213TC	241.30	203.20	133.35	107.95	139.70 (5.50)	10.41	254.76	243.08	34.93	85.73	7.87	35.05	204.47	172.47	79.25	184.15	1/2-13	215.90	114.30	6.35	229.62
215TC	(9.5)	(8.00)	(5.25)	(4.25)	177.80 (7.00)	(0.41)	(10.03)	(9.57)	(1.38)	(3.38)	(0.31)	(1.38)	(8.05)	(6.79)	(3.12)	(7.25)		(8.50)	(4.50)	(0.25)	(9.04)

Note: Dimensions are in mm (in).

* Tap size specified are SAE thread size (no metric equivalent)

Dimension for reference only.

Contact your ABB regional support office for the detailed dimension drawing for your specific catalog number.

NEMA Super-E[®] premium efficient motors

Dimension drawings

Single phase motors - TEFC
 Foot mounted
 NEMA 48 - 184T

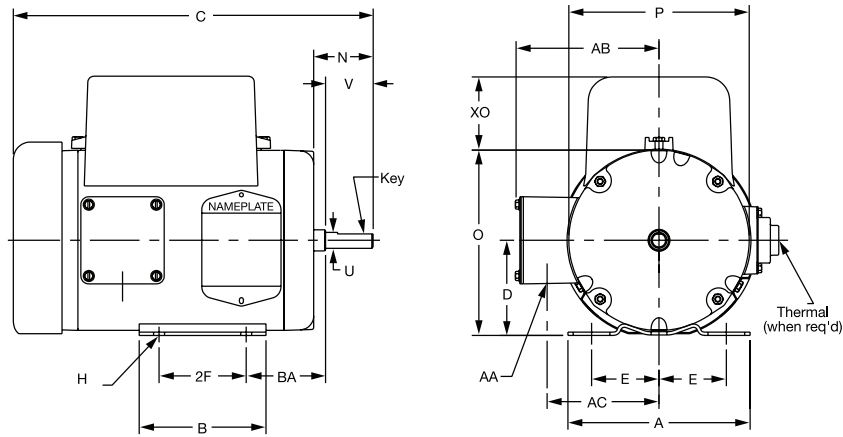

NEMA frame	A	B	D	E	2F	H	Key	N	O	P	U	V	AA	AB	AC	BA	XO
48	0,75-11185 (1-15,000)	101,60 (4)	76,20 (3)	54,10 (2.13)	69,85 (2.75)	8,64 (0.34) Slot	Flat 1,19 (0.047) deep 28,45 (1.12) long	47,50 (1.87)	148,59 (5.85)	144,53 (5.69)	12,70 (0.5)	38,10 (1.5)	22,35 (0.88)	131,57 (5.18)	91,44 (3.6)	63,50 (2.5)	58,67 (2.31) 39,62 (1.56)
56 400 typ	165,10 (6.5)	101,60 (4)	88,90 (3.5)	61,98 (2.44)	76,20 (3)	8,64 (0.34) Slot	4,83 (0.19)	63,50 (2.5)	161,54 (6.36)	144,53 (5.69)	15,88 (0.625)	47,75 (1.88)	22,35 (0.88)	124,46 (4.9)	89,66 (3.53)	69,85 (2.75)	39,62 (1.56) 58,67 (2.31)
56 56H	165,10 (6.5)	114,30 (4.5) 165,10 (6.5)	88,90 (3.5)	61,98 (2.44)	76,20 (3) 127,00 (5)	8,64 (0.34) Slot	4,83 (0.19)	62,74 (2.47) 53,85 (2.12)	172,97 (6.81)	168,15 (6.62)	15,88 (0.625)	47,75 (1.88)	22,35 (0.88)	145,54 (5.73)	117,35 (4.62)	69,85 (2.75)	56,90 (2.24)
143T 145T	165,10 (6.5)	150,88 (5.94)	88,90 (3.5)	69,85 (2.75)	101,60 (4) 127,00 (5)	8,64 (0.34) Slot	4,83 (0.19)	63,50 (2.5)	172,97 (6.81)	168,15 (6.62)	22,23 (0.875)	57,15 (2.25)	22,35 (0.88)	145,54 (5.73)	117,35 (4.62)	57,15 (2.25)	57,15 (2.25)
182T 184T	219,20 (8.63)	165,10 (6.5)	114,30 (4.5)	95,25 (3.75)	114,30 (4.5) 139,70 (5.5)	10,41 (0.41)	6,35 (0.25)	90,42 (3.56)	214,38 (8.44)	200,15 (7.88)	28,58 (1.125)	69,85 (2.75)	27,69 (1.09)	174,50 (6.87)	146,30 (5.76)	69,85 (2.75)	68,33 (2.69)

Note: Dimensions are in mm (in). Dimension for reference only. Contact your ABB regional support office for the detailed dimension drawing for your specific catalog number.

Single phase motors – open drip-proof
 Foot mounted
 NEMA 48 - 184T

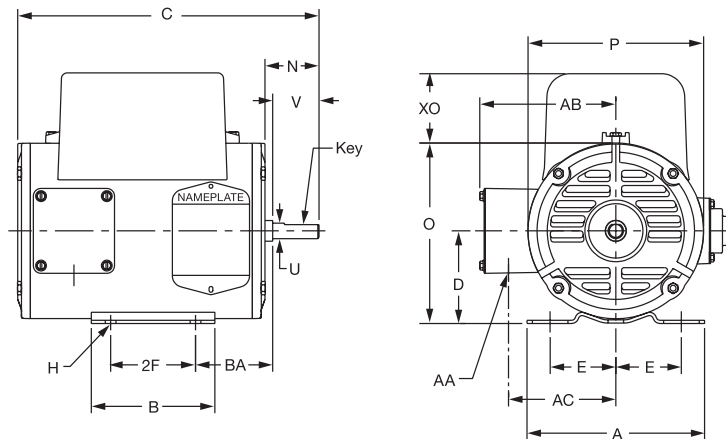

NEMA frame	A	B	D	E	2F	H	Key	N	O	P	U	V	AA	AB	AC	BA	XO
48	146,05 (5.75)	101,60 (4)	76,20 (3)	53,85 (2.12)	69,85 (2.75)	8,64 (0.34) Slot	Flat 1,19 (0.047) deep 28,45 (1.12) long	44,45 (1.75)	148,59 (5.85)	144,53 (5.69)	12,70 (0.5)	38,10 (1.5)	22,35 (0.88)	128,52 (5.06)	89,92 (3.54)	63,50 (2.5)	38,10 (1.5) 57,15 (2.25)
56 400 typ	166,62 (6.56)	101,60 (4)	88,90 (3.5)	61,98 (2.44)	76,20 (3)	8,64 (0.34) Slot	4,83 (0.19)	54,10 (2.13)	161,04 (6.34)	144,53 (5.69)	15,88 (0.625)	47,75 (1.88)	22,35 (0.88)	128,52 (5.06)	89,92 (3.54)	69,85 (2.75)	38,10 (1.5) 57,15 (2.25)
56 56H	165,10 (6.5)	114,30 (4.5) 165,10 (6.5)	88,90 (3.5)	61,98 (2.44)	76,20 (3) 127,00 (5)	8,64 (0.34) Slot	4,83 (0.19)	61,98 (2.44) 54,10 (2.13)	172,97 (6.81)	168,15 (6.62)	15,88 (0.625)	47,75 (1.88)	22,35 (0.88)	142,75 (5.62)	115,82 (4.56)	69,85 (2.75)	55,37 (2.18)
143T 145T	165,10 (6.5)	150,88 (5.94)	88,90 (3.5)	69,85 (2.75)	101,60 (4) 127,00 (5)	8,64 (0.34)	4,83 (0.19)	63,50 (2.5)	172,97 (6.81)	168,15 (6.62)	22,23 (0.875)	57,15 (2.25)	22,35 (0.88)	145,54 (5.73)	117,35 (4.62)	57,15 (2.25)	55,37 (2.18)
182T 184T	219,20 (8.63)	165,10 (6.5)	114,30 (4.5)	95,25 (3.75)	114,30 (4.5) 139,70 (5.5)	10,41 (0.41)	6,35 (0.25)	90,42 (3.56)	214,38 (8.44)	200,15 (7.88)	28,58 (1.125)	69,85 (2.75)	27,69 (1.09)	171,45 (6.75)	146,30 (5.76)	69,85 (2.75)	56,90 (2.24) 66,80 (2.63)

Note: Dimensions are in mm (in). Dimension for reference only. Contact your ABB regional support office for the detailed dimension drawing for your specific catalog number.

NEMA Super-E[®] premium efficient motors

Connection diagrams

CD0005 and 416820-1

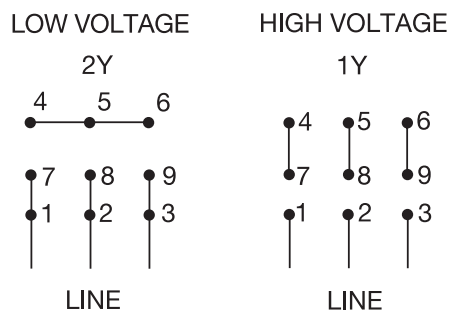
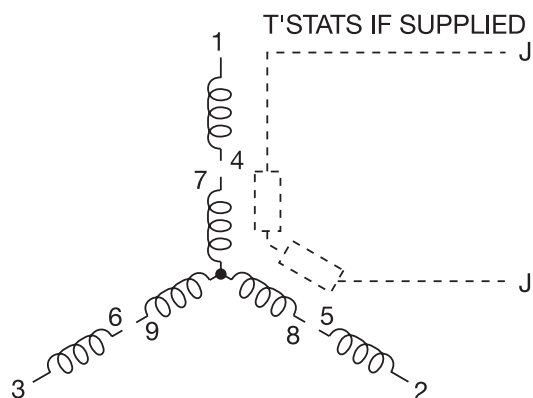

- Notes:**
1. Interchange any two line leads to reverse rotation.
 2. Thermostats are provided when specified.
 3. Actual number of internal parallel circuits may vary.
 4. Lead colors are optional. Leads must be numbered as shown.

CD0006, 416820-24 and 416820-25

TYPICAL WYE-CONNECTED MOTOR

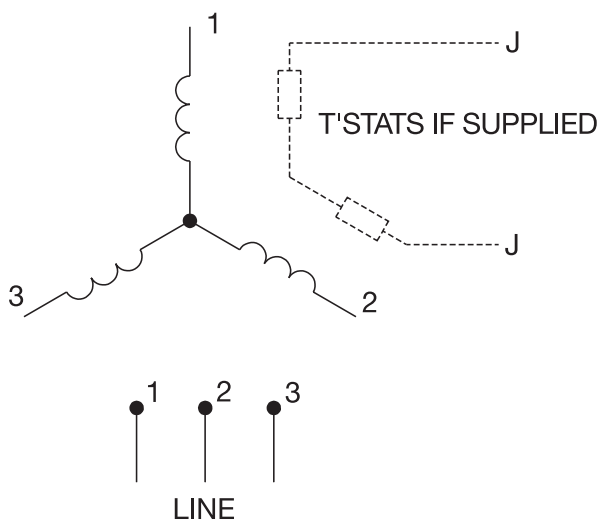

TYPICAL DELTA-CONNECTED MOTOR

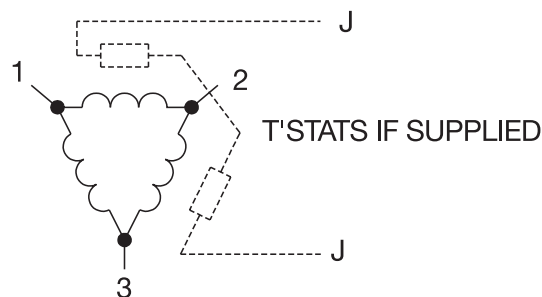

- Notes:**
1. Three lead motors may be designed as either wye-connected or delta-connected.
 2. Interchange any two line leads to reverse rotation.
 3. Thermostats are provided when specified.
 4. Actual number of internal parallel circuits may vary.
 5. Lead colors are optional. Leads must be numbered as shown.

CD0007

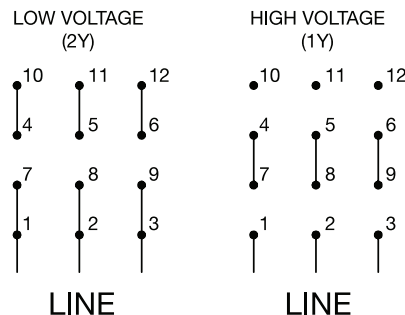
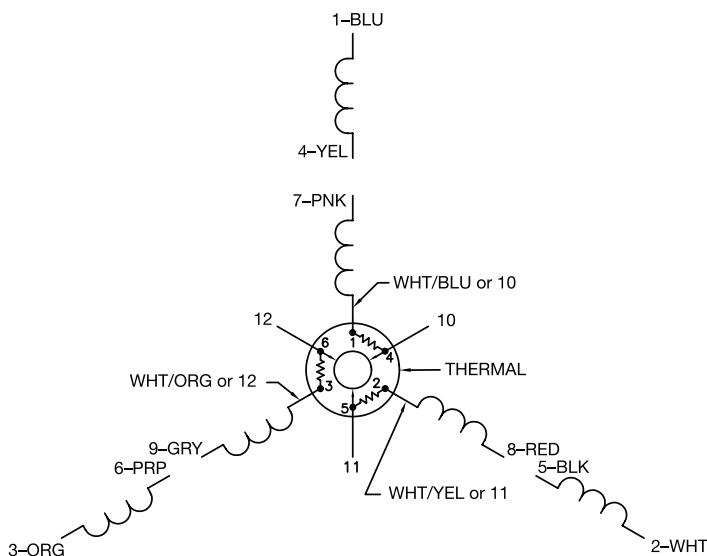

- Notes:**
1. Interchange any two line leads to reverse rotation.
 2. Thermostats are provided when specified.
 3. Actual number of internal parallel circuits may vary.
 4. Lead colors are optional. Leads must be numbered as shown.

NEMA Super-E[®] premium efficient motors

Connection diagrams

CD0017A02

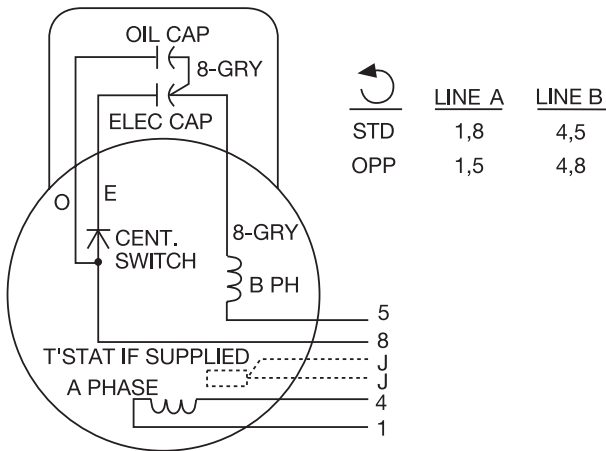

CD0055

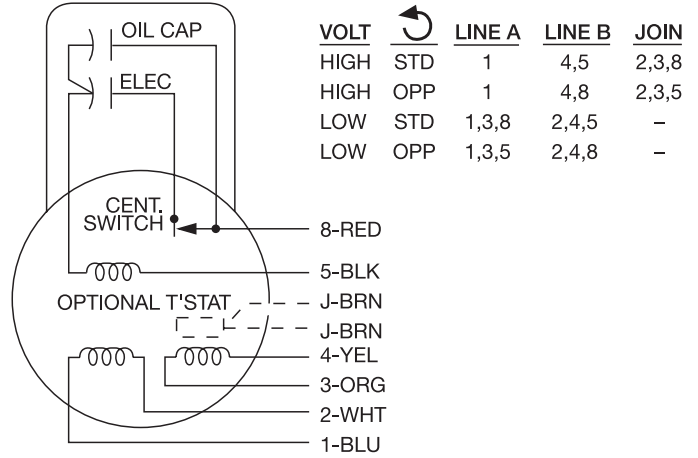

CD0022 and 416820-4

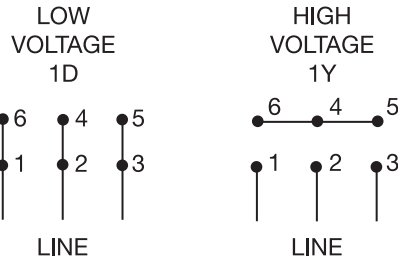
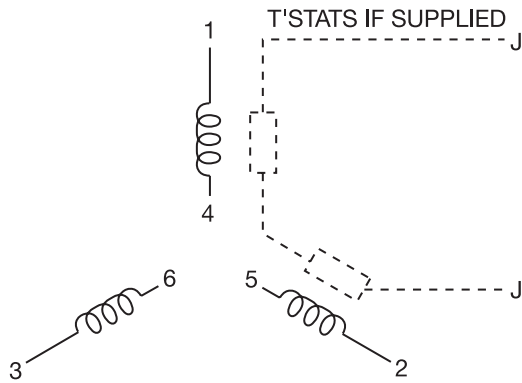

- Notes:**
1. Interchange any two line leads to reverse rotation.
 2. Thermostats are provided when specified.
 3. Actual number of internal parallel circuits may vary.
 4. Lead colors are optional. Leads must be numbered as shown.

CD0104

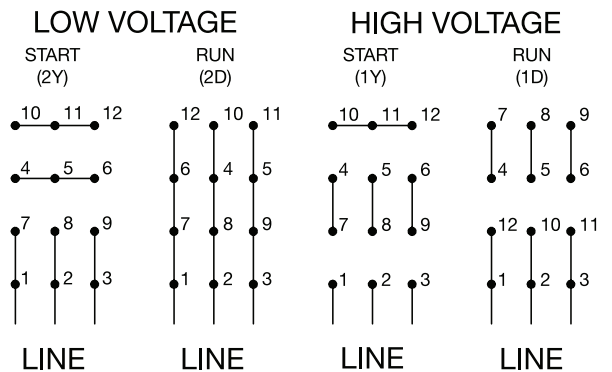
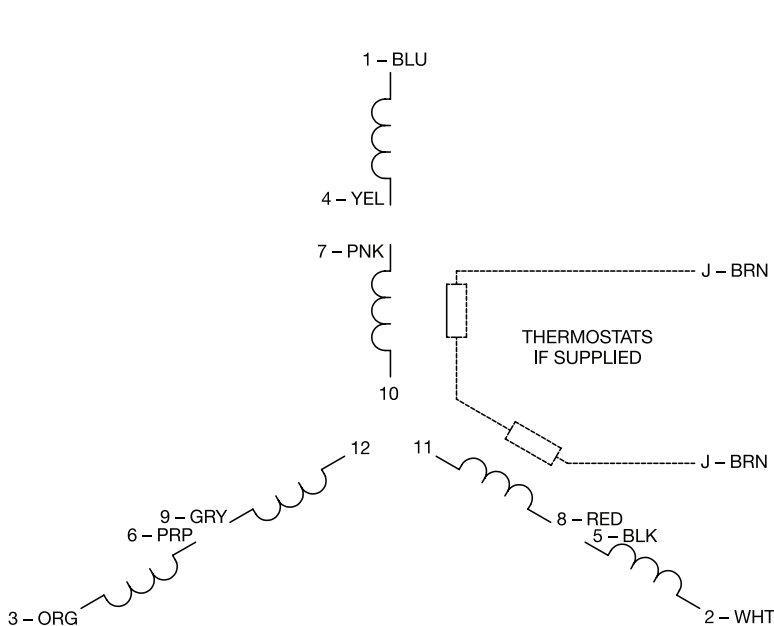

- Notes:**
1. Interchange any two line leads to reverse rotation.
 2. Thermostats are provided when specified.
 3. Actual number of internal parallel circuits may be a multiple of those shown above.
 4. Lead colors are optional. Leads must be numbered as shown.

NEMA Super-E[®] premium efficient motors

Connection diagrams

CD0180 and 416820-2

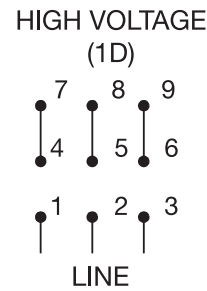
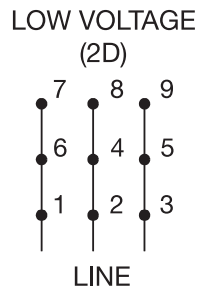
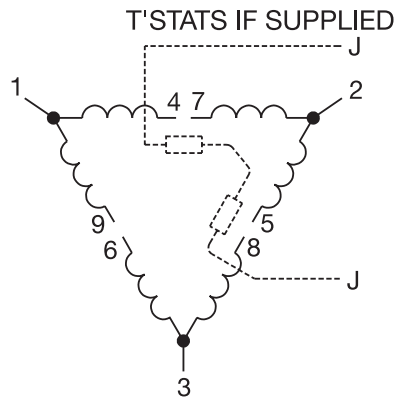

Notes:

1. Three lead motors may be designed as either wye-connected or delta-connected.
2. Interchange any two line leads to reverse rotation.
3. Thermostats are provided when specified.
4. Actual number of internal parallel circuits may vary.
5. Lead colors are optional. Leads must be numbered as shown.

CD0382

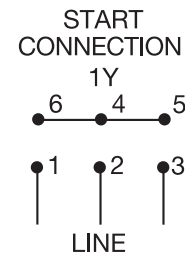
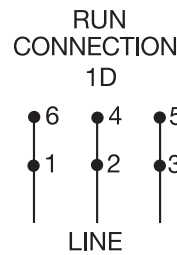
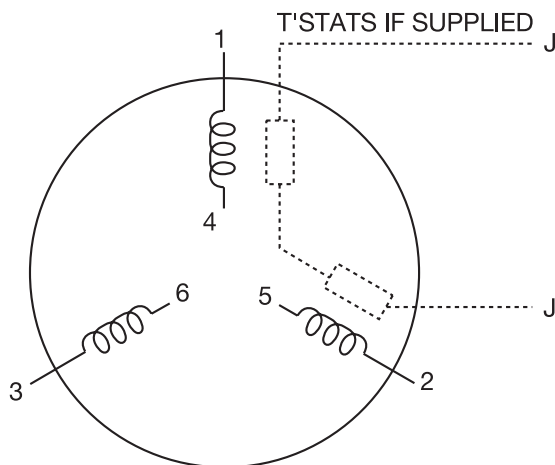

Notes:

1. Interchange any two line leads to reverse rotation.
2. Thermostats are provided when specified.
3. Actual number of internal parallel circuits may vary.
4. Lead colors are optional. Leads must be numbered as shown.
5. For Across-The-Line starting, use "RUN" connection

CD0695

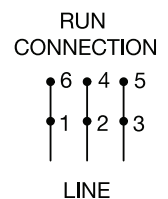
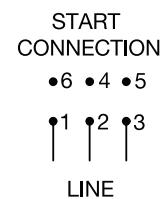
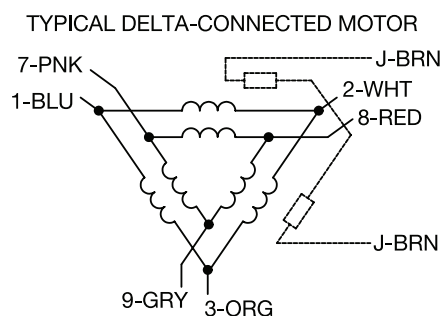
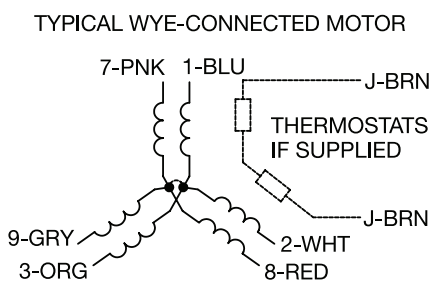

Notes:

1. Motor may be wye-connected or delta-connected.
2. Interchange any two line leads to reverse rotation.
3. Thermostats are provided when specified.
4. Actual number of internal parallel circuits may vary.
5. Lead colors are optional. Leads must be numbered as shown.

NEMA Super-E[®] premium efficient motors

Connection diagrams

416820-008

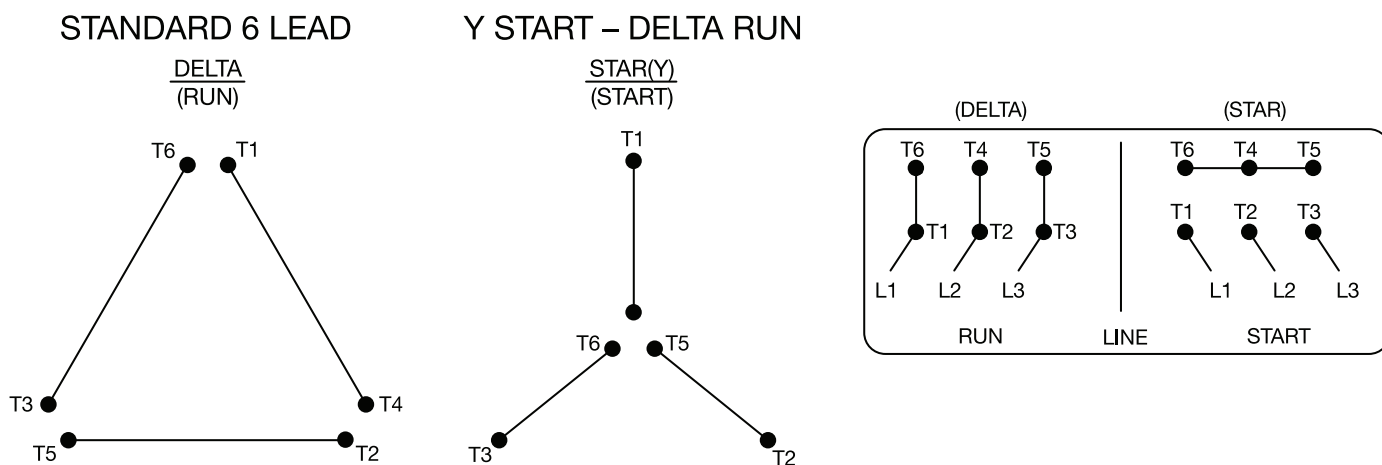

416820-015

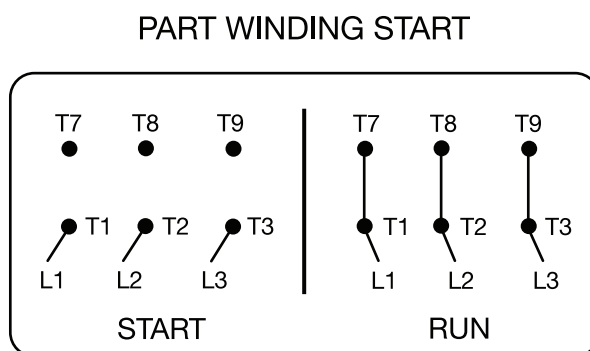

416820-036

STANDARD 3 LEAD CONNECTED

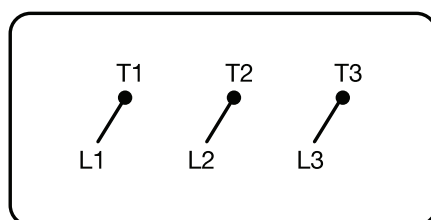

Contact us

www.abb.com/motors&generators

We reserve the right to make technical changes or modify the contents of this document without prior notice. With regard to purchase orders, the agreed particulars shall prevail. ABB Ltd does not accept any responsibility whatsoever for potential errors or possible lack of information in this document.

We reserve all rights in this document and in the subject matter and illustrations contained herein. Any reproduction, disclosure to third parties or utilization of its contents - in whole or in part - is forbidden without prior written consent of ABB Ltd.

© Copyright 2012 ABB. All rights reserved.
Specifications subject to change without notice.