



Product Catalog

Packaged Rooftop Air Conditioners

IntelliPak™ — S*HL, S*HK

20 - 130 Tons — Air-Cooled Condensers — 60 Hz





IntelliPak™ Rooftop Air Conditioners

Designed For Today and Beyond

Innovative technology and an impressive lineup of features make the Trane IntelliPak™ Rooftop line the number one choice for today and the future. The Trane rooftop Unit Control Module (UCM), an innovative, modular microprocessor control design, coordinates the actions of the IntelliPak™ rooftop in an efficient manner and allows for stand-alone operation of the unit. Access to the unit controls, via a Human Interface Panel, provides a high degree of control, superior monitoring capability, and unmatched diagnostic information.

Optionally, for centralized building control on-site, or from a remote location, IntelliPak™ can be configured for direct communication with a Trane Tracer™ building management system or a 3rd party LonTalk® or BACnet building management system, using a twisted pair of wires. With one of these systems, the IntelliPak™ status data and control adjustment features can be conveniently monitored from a central location. IntelliPak™ has the technology *and flexibility* to bring total comfort to every building space.

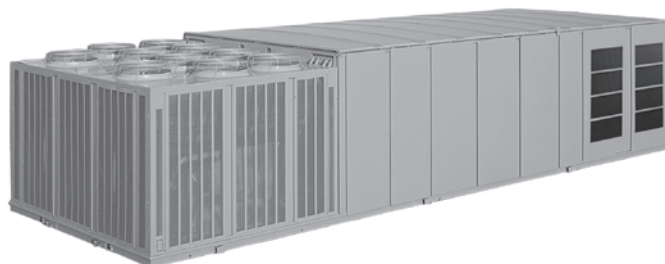

Note: AHRI certifies up to 63 ton units

Copyright

This document and the information in it are the property of Trane, and may not be used or reproduced in whole or in part without written permission. Trane reserves the right to revise this publication at any time, and to make changes to its content without obligation to notify any person of such revision or change.

Trademarks

All trademarks referenced in this document are the trademarks of their respective owners. Statitrac, Tracer Integrated Comfort System, VariTrane, Traq, TOPSS, Froststat, eFlex, eDrive, Tracker, 3-D scroll compressors, Customer Direct Service Network, IntelliPak, Trane and the Trane logo are trademarks of Trane in the United States and other countries. LonTalk, LonWorks, BACnet, Dolphin WaterCare, and Manville Tuf-Skin are registered trademarks.

Revision Summary

RT-PRC036Q-EN (Aug 2014)

- Added Ultra Low Leak Economizer and as standard option for 20-75 ton and design special for 90-130 ton.

Table of Contents

Features and Benefits	6
Standard Features	6
Optional Features	7
Features Summary	8
Integrated Rooftop Systems: Profitable, Simple	10
Integrated Comfort with Trane Tracer™ TCI	11
Trane Control System with LonTalk® and BACnet	12
Building Pressure Control	14
Compressors	15
Microchannel Condenser Coils	16
Rapid Restart	17
Energy Savings, Improved IAQ and Comfort	17
Application Considerations	20
Exhaust/Return Fan Options	20
Exhaust/Return Systems	20
Application Recommendations	20
Horizontal Discharge	23
Capacity/Efficiency Options	27
Miscellaneous Applications	27
Selection Procedure	31
Air-Cooled Rooftop	31
Cooling Capacity Selection	31
Heating Capacity Selection	33
Air Delivery Procedure	34
Hot Gas Reheat	35
Unit Electrical Requirements	36
Altitude Corrections	36
Model Number Descriptions	37
General Data	41
Performance Adjustment Factors	48
Performance Data	50
Air-Cooled Performance Data	50
Supply Fan Performance	86
Controls	117
Rapid Restart (RR) Only	117
Variable Air Volume (VAV) Only	117
Sequence Of Operation	117

Single Zone Variable Air Volume (SZVAV) Only	119
Constant Volume (CV) Only	122
Sequence Of Operation	122
CV, SZVAV, and VAV	123
Electrical Data	134
Dimensional Data	139
Field Installed Sensors	145
Weights	148
Options	149
Mechanical Specifications	152
General	152
Casing	152
Refrigeration System	152
Air-Cooled Condensing	153
Air Handling System	153
Controls	155
Filters	155
Exhaust Air	156
Return Air	158
Outside Air	158
Heating System	160
Miscellaneous Options	161
Accessories	163



Features and Benefits

Standard Features

- 20 to 130 ton industrial/ commercial rooftops
- R-410A Refrigerant
- ASHRAE 90.1 - 2010 Efficiency Compliant
- cULus approval on standard options

Controls

- Fully integrated, factory-installed/ commissioned microelectronic controls
- Unit mounted Human Interface Panel with a 2 line x 40 character English display and a 16 function keypad that includes Custom, Diagnostics, and Service Test mode menu keys.
- CV or VAV, or Single Zone VAV control
- Low ambient compressor lockout control on units with economizers
- Frostat™ coil frost protection on all units
- Daytime warm-up (occupied mode) on VAV models and Morning warm-up operation on all units with heating options
- Supply air static over-pressurization protection on units with VFDs.
- Return air static over-pressurization protection on units with return fan option.
- Supply airflow proving
- Exhaust/return airflow proving on units with exhaust/return option
- Supply air tempering control
- Supply air heating control on CV or VAV units with Discharge Temp Control modulating gas, hot water or steam heat units
- Mappable sensors and setpoint sources
- Occupied/Unoccupied switching
- Emergency stop input
- Low Charge Protection
- Dirty filter switch
- Phase Monitor ((20-75 ton)
- Humidification input
- Freeze Avoidance

Refrigeration

- Trane 3-D® scroll compressors or eFlex™ Variable Speed Compressors on 40-70 ton units
- Compressor or circuit lead/lag depending on unit
- Intertwined Evaporator Coil circuiting for full face area operation at part load conditions
- Microchannel condenser coil
- Liquid and Discharge Service Valves

Cabinet

- Hinged access doors on control panel, filter section, and gas heat section
- Horizontal discharge/return duct connections (SX, SL, SS, SF models)
- Pitched roof over air handler section
- Heavy-gauge, single-piece construction base rails
- Meets salt spray testing in accordance to ASTM B117 Standard

Mechanical

- Forward-curved supply fans or eDrive™ direct drive plenum fans (20-75 ton)
- Airfoil supply fans (90-130 ton)
- Stainless steel flue stack on gas heat units
- Two-inch high efficiency throwaway filters
- Two-inch spring fan isolation

Optional Features

For a comprehensive listing of standard options, special options, and accessories, please see “Options,” p. 149, Table 82.

Controls

- Trane Communication Interface Module: ICS interface control module
- LonTalk® Communication Interface Module
- BACnet Communication Interface Module
- Remote Human Interface Panel (controls up to 4 units)
- Five ventilation override sequences
- Generic BAS interface 0-5 VDC and 0-10 VDC
- Variable frequency drive control of supply/exhaust/return fan motor
- Single Zone VAV Control
- Rapid Restart
- High duct temperature thermostats pressurization control
- 0°F low ambient control
- Power supply monitoring (90-130 ton)
- Correction capacitors
- Economizer Fault Detection and Diagnostics (FDD) control as required by California Title 24 provided with Ultra Low Leak economizers.

Refrigeration

- eFlex™ Variable Speed Compressor (40-70 ton)
- Hot gas bypass to the evaporator inletModulating hot gas reheat
- Suction service valvesReplaceable core filter driers
- High capacity unit (40-75 ton)
- High efficiency unit (20-75 ton)
- High capacity evaporator coil (90 and 105 tons)
- High efficiency condenser coil (90 ton models)
- Corrosion protected condenser coil
- Copper evaporator coils

Cabinet

- Extended casing (SX models)
- Double wall access doors
- Double wall construction/perforated double wall
- Stainless steel drain pan in evaporator section
- Pitched evaporator drain pan
- Horizontal or Roof discharge on certain configurations (20-75 tons "L" style units only)
- IntelliPak™ Replacement Unit (IRU)
- Special paint colors

Mechanical

- eDrive™ direct drive plenum supply fans; 80% or 120% wheel width (20-75 tons)
- eDrive™ direct drive plenum design special supply fans; 100% wheel width (50-55 tons)
- Supply fan piezometer for direct drive plenum airflow measurement
- Outside air CFM compensation on VAV units with VFD and economizer
- Barometric relief
- Low Leak, and Ultra Low Leak 0-100 percent modulating outside air economize
- 0-100 percent modulating outside air economizer

Features and Benefits

- Ultra Low Leak Power Exhaust dampers provided when Ultra Low Leak economizer and Power Exhaust options are ordered
- Choose from three economizer control options: comparative enthalpy, reference enthalpy, dry bulb control
- Trane Outside Air Measurement (Traq™)
- 5 year limited warranty on Ultra Low Leak Economizer damper, linkage, and actuator
- 10 year limited warranty on Full Modulation Gas Heat
- 50 percent modulating exhaust with forward-curved fans
- 100 percent modulating exhaust with forward-curved fans
- 100 percent modulating exhaust with FC fans and Statitrac™ direct space sensing building pressurization control
- 100 percent modulating return with airfoil fans (20-75 ton)
- 100 percent modulating return with AF fans and Statitrac™ direct space sensing building (20-75 ton)
- Two-inch spring fan isolation (20-75 ton)
- U-frame motors
- Oversized motors
- Motors with internal shaft grounding ring for VFD applications

Filtration

- Filter rack only (no filters)
- High efficiency throwaway filters, MERV 8
- 90-95 percent bag filters, MERV 14
- 90-95 percent cartridge filters, MERV 14
- Final filters, cartridge filters, MERV 14
- Differential pressure gauge

Heat

- Heating options: natural gas, electric, hot water or steam
- Modulating Gas Heat

Electrical

- Dual electrical power connection
- Through the door non-fused disconnect with external handle
- Electrical convenience outlet

Field Installed Accessories

- Roof curbs
- Programmable sensors with night set back - CV and VAV
- Sensors without night set back - CV and VAV
- Remote zone sensors - used for remote sensing with remote panels.
- ICS zone sensors used with Tracer™ system for zone control
- Outdoor temperature sensor for units without economizers
- Remote minimum position control for economizer
- Field installed module kits available for field upgrade of controls
- Humidity Sensor
- BCI and LCI communication boards
- Wireless Comm Interface (WCI)

Features Summary

IntelliPak™ rooftop features make installation and servicing easy — and reliable operation a reality.

Installation Ease

- Factory-installed/commissioned controls
 - ease of startup
 - single twisted wire pair
 - communication for ICS interface
 - full unit points access, no field wiring of required points
- Unit mounted Human Interface Panel standard
 - user friendly keypad - edit
 - parameters
 - through the access door interface
 - startup adjustments
 - unit mounted and remote interface panel key pads are identical
- Unit mounted lifting lugs facilitate installation and can be used as unit tie-down points.

Easy to Service

- The microprocessor unit controls coordinates the operation of the rooftop with quality, industry-accepted components for service ease.
- Unit mounted Human Interface Panel standard
 - user friendly keypad - edit parameters
 - through the access door interface
 - startup adjustments
 - unit mounted and remote interface panel key pads are identical
- Modularity of unit control design
 - individual replaceable functional boards
- Advanced diagnostics

Reliability

- Advanced diagnostics
- Microprocessor controls
- Built-in safeties
- Modular control design
- cULus approval as standard
- Forward-curved supply and exhaust fans and airfoil supply and return fans are factory balanced.
- Design-special, direct-drive plenum supply fans reduce components for increased supply fan reliability.
- Fully insulated and gasketed panels reduce ambient air infiltration.
- Standard fixed-speed evaporator fan and optional exhaust/return drive offer smooth fan operation and belt durability.
- Standard with Froststat™ on all units as well as Freeze avoidance on hydronic heat units
- 200,000 hour average fan shaft and motor bearings enhance life of unit.
- Gas heater with free-floating stainless steel heat exchanger relieves the stresses of expansion and contraction. Stainless steel provides corrosion resistance through the entire material thickness.

Features and Benefits

- Integral condenser subcooler improves efficiency while helping avoid liquid flashing.
- Factory-wired and commissioned controls assure efficient and reliable rooftop operation.
- Trane Scroll compressors are designed for tough industrial operation and meet demanding operating conditions both in efficiency and reliability.
- Variable Speed Compressors are designed to modulate refrigerant flow achieving outstanding partial load ratings (IEER).
- Standard phase monitors for compressor protection on 20-75 ton units.
- Roll-formed construction enhances cabinet integrity and assures a leakproof casing.
- Three-phase, direct-drive condenser fan motors enhance dependability and increase rooftop life.
- Trane industrial quality evaporator and condensing coils help increase rooftop life.

Application Flexibility

- Modularity in design
- Increased offering of standard options
- Generic BAS interface
- Five factory preset/re-definable in the field ventilation override sequences
- Superior Tracer™ interface for ICS applications
 - factory-installed Trane
- Superior LonTalk® interface for Tracer™ and 3rd party applications
 - factory or field-installed LonTalk® Communication Interface
- Superior BACnet interface for Tracer™ SC or 3rd party applications
 - factory or field-installed BACnet communication interface
 - Field installed Wireless Comm through BCI add available
- Unit mounted or Remote Human Interface panels
 - all parameter are editable from the Human Interface Panel
- Traq™ outside air measurement to meet LEED IEQ Credit 1
- Comparative enthalpy, Reference enthalpy, or Dry bulb control for economizers
- Statitrac™ direct space building pressure control
- Compensated outdoor air control - IAQ
- Factory-installed filter rack includes two-inch throwaway filters.
- CV controls stage both compressors and heat based on space requirements.
- Variable Frequency Drives (VFD) Included With or Without Bypass Control for Supply and Exhaust/Return Fans.
- Higher efficiency units with evaporative condensing option
- Dehumidification control with modulating hot gas reheat
- An array of heating options are available, including Steam, Hot Water, Electric and Natural Gas heat. The Gas Heating option provides a choice of two-stage gas heat, as well as full and limited modulating gas heat.

Integrated Rooftop Systems: Profitable, Simple

Trane integrated rooftop systems make design and installation of building management systems cost effective and easy. Trane offers three choices for building management controls: Tracer™

building automation system with a Trane Control Interface (TCI), LonTalk® Communication Interface (LCI) or Tracer™ SC with BacNet Communication Interface (BCI).

Integrated Comfort with Trane Tracer™ TCI

The Tracer™ TCI Integrated Comfort System (ICS) improves job profit and increases job control by combining Trane rooftop units with the Trane Tracer™ building management system. This integrated system provides total building comfort and control. Some of the primary motivations for building owners/managers in deciding to purchase a HVAC controls system is energy savings, cost control, and the convenience of facility automation.

Simplifying the Comfort System

Trane technology and innovation brings more capabilities, more flexibility, and at the same time, offers equipment and systems that are easy to use, easy to install, commission, and service. The Tracer™ TCI Integrated Comfort system saves time and money by simplifying system design and system installation. When used with Trane DDC/VAV boxes (or VariTrane™), system balancing almost goes away because each VAV box is commission and tested before it leaves the factory. All the status information and editing data from the rooftop units, VAV boxes, lighting, exhaust and other auxiliary equipment is available from Tracer™ TCI for control, monitoring and service support of your facility. Tracer™, a family of building automation products from Trane, is designed with robust, application specific software packages to minimize custom programming requirements and enable system setup and control through simple editing of parameters in the standard applications software. Should you select an Integrated Comfort system for your facility, the accountability for equipment, automation and controls belongs to Trane.

The IntelliPak™ rooftop, as a part of an Integrated Comfort system, provides powerful maintenance monitoring, control and reporting capabilities. The Tracer™ places the rooftop in the appropriate operating mode for operation for: system on/off, night setback, demand limiting, setpoint adjustment based on outside parameters and much more. Up to 56 different unit diagnostic conditions can be monitored through Tracer™ to let you know about things like: sensor failures, loss of supply airflow, and a compressor trip out. Further, the addition of Building Management Network software offers remote scanning, automatic receipt of alarms, and easy dial-up access to over 100 various Tracer™ sites across town or across the country.

IntelliPak™ Rooftops monitoring points available through Tracer™

- All active Rooftop diagnostics
- History of last 20 unit diagnostics
- All system setpoints
- System sensor inputs
- Supply fan mode and status
- VFD speed

- Unit heat/cool mode
- Exhaust fan status
- Exhaust damper position
- Economizer position, minimum position setpoint, economizing setpoint
- On/off status of each compressor
- Refrigerant evaporator and saturated condenser temperatures
- Hydronic heat valve position
- Electric heat stage status
- Ventilation override mode status



Features and Benefits

Tracer™ control points for IntelliPak™ Rooftops

- Cooling and heating setpoints
- Zone setpoint offsets for use with demand limiting
- Discharge air setpoints
- Supply air pressure setpoint
- Space pressure setpoint
- Zone and outdoor temperature values
- Cooling and heating enable/disable
- Economizer enable/disable
- Economizer setpoint
- Economizer minimum position
- Activation of ventilation override modes
- Diagnostics reset
- Unit priority shutdown
- Timed override activation

IntelliPak™ Rooftops setup and configuration information through Tracer™

- Supply fan mode
- Configuration of supply air reset
- Ventilation override mode configuration
- Default system setpoint values
- Sensor calibration offsets

Trane Control System with LonTalk® and BACnet

Interoperability with LonTalk®

The Trane Tracer™ LonTalk® Control Interface (LCI) for IntelliPak™ offers a building automation control system with outstanding interoperability benefits. LonTalk®, which is an industry standard, is an open, secure and reliable network communication protocol for controls, created by Echelon Corporation and adopted by the LonMark Interoperability Association. It has been adopted by several standards, such as: EIA-709.1, the Electronic Industries Alliance (EIA) Control Network Protocol Specification and ANSI/ASHRAE 135, part of the American Society of Heating, Refrigeration, and Air-Conditioning Engineer's BACnet control standard for buildings.

Interoperability allows application or project engineers to specify the best products of a given type, rather than one individual supplier's entire system. It reduces product training and installation costs by standardizing communications across products.

Interoperable systems allow building managers to monitor and control IntelliPak™ equipment with a Trane Tracer Summit®, Tracer™ SC or a 3rd party building automation system. It enables integration with many different building controls such as access/intrusion monitoring, lighting, fire and smoke devices, energy management, and a wide variety of sensors (temperature, pressure, light, humidity, occupancy, CO₂ and air velocity). For more information on LonMark, visit www.lonmark.org or Echelon, www.echelon.com.

Note: *LonTalk® and LonWorks® are registered trademarks of Echelon Corporation.*

Interoperability with BACnet

The Trane Tracer™ SC BACnet Control Interface (BCI) for IntelliPak™ offers a building automation control system with outstanding interoperability benefits. BACnet, which is an industry standard, is an open, secure and reliable network communication protocol for controls, created by American Society of Heating, refrigerating and Air-Conditioning Engineers, Inc. (ASHRAE).

Interoperability allows application or project engineers to specify the best products of a given type, rather than one individual supplier's entire system. It reduces product training and installation costs by standardizing communications across products.

Interoperable systems allow building managers to monitor and control IntelliPak™ equipment with Tracer™ SC controls or a 3rd party building automation system. It also enables integration with many different building controls such as access/intrusion monitoring, lighting, fire and smoke devices, energy management, and a wide variety of sensors (temperature, pressure, light, humidity, occupancy, CO₂ and air velocity).

Typical points available through BACnet:

- All Rooftop diagnostics
- System setpoints
- System sensor inputs
- Supply fan mode and status
- VFD speed
- Unit heat/cool mode
- Exhaust fan status
- Exhaust damper position
- Economizer position, minimum position setpoint, economizing setpoint
- On/off status of each compressor
- Refrigerant evaporator and saturated condenser temperatures
- Hydronic heat valve position
- Electric heat stage status
- Ventilation override mode status

Control points for IntelliPak™ Rooftops:

- Cooling and heating setpoints
- Zone setpoint offsets for use with demand limiting
- VAV discharge air setpoints
- Supply air pressure setpoint
- Space pressure setpoint
- Zone and outdoor temperature values
- Cooling and heating enable/disable
- Economizer enable/disable
- Economizer setpoint
- Economizer minimum position
- Activation of ventilation override modes
- Diagnostics reset
- Unit priority shutdown
- Timed override activation

IntelliPak™ Rooftops setup and configuration information:

- Supply fan mode
- Configuration of supply air reset
- Ventilation override mode configuration
- Default system setpoint values
- Sensor calibration offsets

Optimum Building Comfort Control

The modular control design of the UCM allows for greater application flexibility. Customers can order exactly the options required for the job, rather than one large control package. Unit features

Features and Benefits

are distributed among multiple field replaceable printed circuit boards. The Trane UCM can be set up to operate under one of three control applications:

1. Stand-alone
2. Interface with Trane Tracer™ building management system
3. Interface with a generic (non-Trane) building management system. All setup parameters are preset from the factory, requiring less start-up time during installation.

The unit mounted Human Interface and the Remote Human Interface Panels' functions are identical, except for the Service mode is not available on the Remote Human Interface Panel. This common interface feature requires less time for building maintenance personnel to learn to interact with the unit.

All of the rooftop's control parameters are adjustable and can be set up through the Remote Human Interface Panel such as, but not limited to: system on/off, demand limiting type, night setback setpoints, and many other setpoints. No potentiometers are required for setpoint adjustment, all adjustments are done through the Remote Human Interface keypad. Also up to 56 different rooftop diagnostic points can be monitored through the human interfaces such as: sensor failures, loss of supply airflow, and compressor trip.

No special tools are required for servicing of the unit. All diagnostic displays are available in clear English at the Remote Human Interface and will be held in memory, so that the operator/servicer can diagnose the root cause of failures.

Trane Wireless Comm Interface (WCI) - Field Installed

The Trane Wireless Comm Interface (WCI) is the perfect alternative to Trane's BACnet™ wired communication links (for example, Comm links between a Tracer™ SC and a Tracer™ UC400). Minimizing communication wire use between terminal products, zone sensors, and system controllers has substantial benefits. Installation time and associated risks are reduced. Projects are completed with fewer disruptions. Future re-configurations, expansions, and upgrades are easier and more cost effective.

Building Pressure Control

Statitrac™ Direct Space Building Pressurization Control

Trane's Statitrac™ control is a highly accurate and efficient method of maintaining building pressure control with a large rooftop air conditioner.

The efficiency is achieved with a 100 percent modulating exhaust system that only operates as needed. Most of the operating hours of the 100 percent modulating exhaust system are at part load, saving more energy. Trane's Statitrac™, with the 100 percent modulating exhaust system, provides comfort and economy for buildings with large rooftop air conditioning systems.

Statitrac™ control is simple. The space pressure control turns the exhaust fans on and off as required and modulates exhaust dampers to maintain space pressure within the space pressure dead band. Using the unit mounted Human Interface Panel you can:

1. Adjust space pressure setpoint
2. Adjust space pressure dead band
3. Measure and read building space pressure. The modulating exhaust system maintains the desired building pressure, saving energy while keeping the building at the right pressure. Proper building pressurization eliminates annoying door whistling, doors standing open, and odors from other zones.

The Statitrac™ direct space building control sequence will be maintained when a variable frequency drive is used.

Statitrac™ Control with Plenum Return Fan is State of the Art

Other manufacturers utilize a fan tracking control scheme whereby the return fan speed tracks the supply fan speed in a linear fashion. This scheme works well at minimum and maximum CFM airflow. However, due to the dissimilar performance characteristics of the supply and return fan, building pressure is difficult to control at points between minimum and maximum CFM airflow.

The Trane return fan/building pressurization control system eliminates the effects of dissimilar supply/return fan characteristics experienced in a linear tracking control system by modulating the exhaust dampers based on space pressure, the return/economizer dampers based on ventilation requirements, and the return fan speed based on return plenum static pressure. The supply fan, return fan, exhaust damper, and return/economizer damper systems act independently from one another to maintain comfort and building pressure.

The return fan operates whenever the supply fan is in operation. The unit exhaust dampers are modulated in response to the space pressure signal to maintain space pressure within the space pressure deadband. The unit economizer and return air dampers are modulated based on ventilation control, minimum outside air economizer position, and economizer cooling request. The return fan speed is modulated based on a return duct static pressure deadband control. Using the unit mounted Human Interface, the operator can:

1. Adjust space pressure setpoint
2. Adjust space pressure deadband
3. Measure and read building space pressure
4. Measure and read return duct static pressure.

Proper building pressurization eliminates annoying door whistling, doors standing open, and odors from other zones.

Variable Frequency Drives (VFD)

Variable Frequency Drives are factory installed and tested to provide supply/exhaust/return fan motor speed modulation. VFD's, as compared to discharge dampers, are quieter, more efficient, and are eligible for utility rebates. The VFD's are available with or without a bypass option. Bypass control will simply provide full nominal airflow in the event of drive failure.

Compressors

Trane 3-D® Scroll Compressors

The Trane 3-D® Scroll provides important reliability and efficiency benefits inherent to its design. The 3-D® Scroll allows the orbiting scrolls to touch in all three dimensions forming a completely enclosed compression chamber which leads to increased efficiency.

In addition, the orbiting scrolls only touch with enough force to create a seal; thereby resulting in no wear between the scroll involutes. The fixed and orbiting scrolls are made of high strength cast iron which results in less thermal distortion and minimal leakage. In addition, better part isolation has resulted in reduced compressor sound levels compared to previous designs.



Features and Benefits

Features listed below optimize the compressor design and performance:

- Optimized scroll profile
- Heat shield protection to reduce heat transfer between discharge and suction gas
- Improved sealing between condenser side and air handler side

Additional features are incorporated in the compressor design for greater compressor reliability:

- Patented design motor cap for improved motor cooling
- Improved bearing alignment
- Improved resistance to dry start up
- Oil sight glass for evaluating proper oil levels

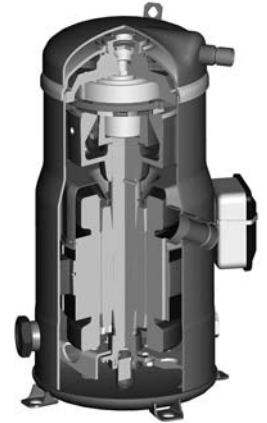

Low Torque Variation

The 3-D® Scroll compressor has a very smooth compression cycle. This means that the scroll compressor imposes very little stress on the motor resulting in greater reliability. Low torque variation reduces noise and vibration.

Suction Gas Cooled Motor

Compressor motor efficiency and reliability is further optimized with the latest scroll design. The patented motor cap directs suction gas over the motor resulting in cooler motor temperatures for longer life and better efficiency.

eFlex™ Variable Speed Scroll Compressor

Trane eFlex™ variable speed scroll compressors are matched with a specially designed variable frequency drive that allows a modulating ratio of up to 4:1. Our eFlex™ compressors are paired with fixed speed compressors such that the units are capable of continuous capacity modulation from 15% to 100%. By design, unit capacity stages overlap to eliminate the frequent cycling between stages typical of competing designs. This allows for unmatched control of leaving air temperatures to meet space loads.

The eFlex™ compressors also include brushless permanent magnet motors designed to operate at higher efficiency along with reducing the compressor motor speed and staging results in significant part load energy savings. This makes units with eFlex™ compressors the most efficient products in their class at part load.

Microchannel Condenser Coils

Microchannel coils are an all aluminum coil that has been successfully used in the automotive industry for many years, and is now being applied in the HVAC industry. The coils have a fully-brazed construction which increases coil rigidity making them more rugged to withstand the rigors of jobsite handling.

Additionally, the light weight simplifies coil handling. The all aluminum construction creates an exceptional heat transfer capability, allowing the refrigerant charge to be reduced to levels that exceed LEED EA-Credit 4 requirements. Bottom line, less refrigerant is being used, which creates a healthier and greener environment.

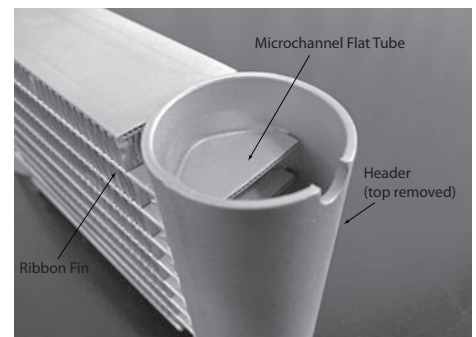

Rapid Restart

Trane understands that every second counts. Trane equipment, controls, and control sequences are designed to get the system back online and properly functioning should the facility experience a power cycle event.

- Trane HVAC system design is optimized for fast restart.
- IntelliPak™ Rooftop System controls and equipment provide an integrated, pre-engineered solution for fast restart.
- Proven operational procedures maximize uptime outside of critical outages and get the system up and running as quickly as possible.

With Rapid Restart and use of a backup generator, the IntelliPak™ Rooftop System can provide full cooling in 120 seconds or less after regaining electrical power. This option is fully integrated into the IntelliPak™ controls logic via standard human interface. Rapid Restart is a perfect fit in time-sensitive applications where extended down time is not an option and heating/cooling is crucial.

Energy Savings, Improved IAQ and Comfort

IntelliPak™ offers several ways to save energy while improving indoor air quality (IAQ) and zone comfort. Standard factory installed options for energy savings include hot gas reheat and evaporative condensers.

Single Zone VAV (SZVAV)

Single Zone VAV (SZVAV) is designed for use in single zone applications such as gymnasiums, auditoriums, manufacturing facilities, retail box stores, and any large open spaces where there is a diversity in the load profile. It is an ideal replacement to "yesterday's" constant-volume (CV) systems, as it reduces operating costs while improving occupant comfort.

SZVAV systems combine Trane application, control and system integration knowledge to exactly match fan speed with cooling and heating loads, regardless of the operating condition. Trane algorithms meet and/or exceed ASHRAE 90.1- 2010 SZVAV energy-saving recommendations and those of CA Title 24. The result is an optimized balance between zone temperature control and system energy savings. Depending on your specific application, energy savings can be as much as 20+%.

Note: *Building system modeling in energy simulation software such as TRACE is recommended to evaluate performance improvements for your application.*

SZVAV is fully integrated into the IntelliPak™ Control system. It provides the simplest and fastest commissioning in the industry through proven factory-installed, wired, and tested system controllers. All control modules, logic boards and sensors are factory installed and tested to ensure the highest quality and most reliable system available. This means no special programming of algorithms, or hunting at the jobsite for field installed sensors, boards, etc. Single zone VAV is a quick and simple solution for many applications and is available from your most trusted rooftop VAV system solution provider -Trane.

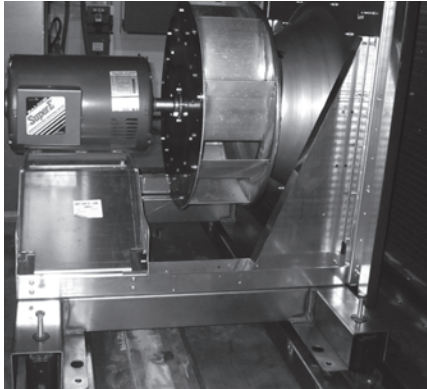

eDrive™ Direct-Drive Plenum Fans

In addition to higher reliability, direct-drive plenum fans offer higher fan efficiency at AHRI rating points. Direct drive plenum fans have a peak operating efficiency which is typically 10-20% more efficiency than traditional housed fans. Trane offers two fan widths to optimize fan efficiency for the building system. Since there are some low static applications, where forward-curved fans may be the best choice, use Trane's TOPSS™ computer software selection program to select the most efficient fan option for your system design. Direct-drive plenum fans are offered as a design special with evaporative condenser units.

High-Efficiency Unit

This option offers improved unit efficiency. All high-efficiency units meet CEE Tier 2 requirements for unitary equipment. This allows opportunities for owners to take advantage of valuable utility rebates for using energy-efficient equipment.

Trane Air Quality (TraQ™) Outside Air Measurement System

Trane Air Quality (TraQ™) outside air measurement system uses velocity pressure sensing rings to measure airflow in the outside air opening from 40 cfm/ton to maximum airflow. Measurement accuracy is at least $\pm 15\%$, meeting requirements of LEED IE Q Credit 1.

Modulating Hot Gas Reheat

This option allows for active reheat control at either part or no load conditions. It is particularly beneficial for applications that need humidity control when little or no sensible load exists. A reheat condenser coil is factory installed downstream of the unit evaporator coil. Modulating valves control the flow of refrigerant between the indoor reheat and outdoor condensers in response to the unit discharge air temperature, see [Figure 1, p. 18](#). Modulating hot gas reheat uses part of the waste heat from condenser heat rejection and thereby saves energy for humidity control applications that would otherwise require a supplemental reheat energy source (e.g. electric heat).

Figure 1. Hot gas reheat schematic

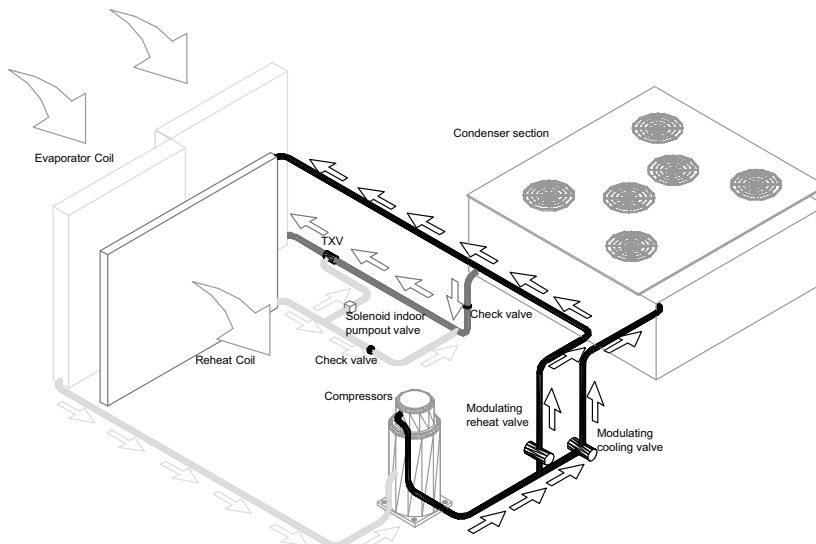

Evaporative Condensing Units

Unlike air-cooled condensers, evaporative condensers are dependent on the ambient wet bulb, rather than dry bulb, temperature. Wet bulb temperature is generally several degrees lower than dry bulb. Utilizing the lower wet bulb temperature to condense refrigerant vapor can dramatically decrease compressor power consumption by reducing compressor discharge pressure thereby increasing unit efficiency. Once thought of as limited to dry/arid climates, people are finding evaporative condensing useful in virtually any climate. To help with this determination, Standard Trane Selection systems (TOPSS) provides performance and kW outputs to help define which option is right for your application.

Figure 2. Evaporative condenser flow schematic

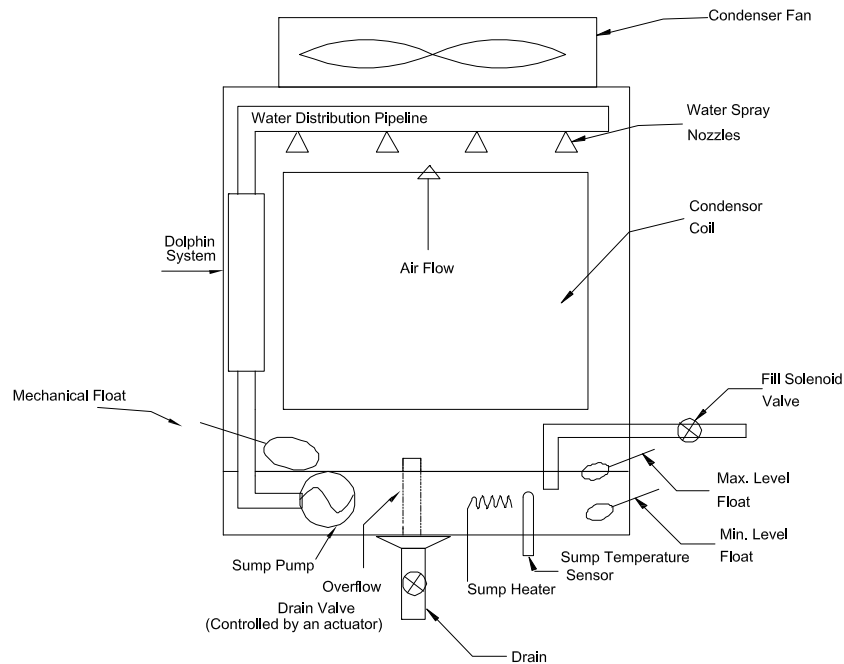

Application Considerations

Exhaust/Return Fan Options

When is it necessary to provide building exhaust? Whenever an outdoor air economizer is used, a building generally requires an exhaust system. The purpose of the exhaust system is to exhaust the proper amount of air to prevent over or under-pressurization of the building. The goal is to exhaust approximately 10 percent less air than the amount of outside air going into the building. This maintains a slightly positive building pressure.

The reason for applying either a return, or exhaust fan is to control building pressure. The Trane 100 percent modulating exhaust system with Statitrac is an excellent choice for controlling building pressure in the majority of applications. For more demanding applications, Trane's 100 percent modulating return fan system with Statitrac is an excellent choice for systems with high return static pressure losses, or duct returns. Both systems employ direct digital control technology to maintain building pressure. Either return or exhaust fan systems with Statitrac may be used on any rooftop application that has an outdoor air economizer.

A building may have all or part of its exhaust system in the rooftop unit. Often, a building provides exhaust external to the air conditioning equipment. This external exhaust must be considered when selecting the rooftop exhaust system.

With an exhaust fan system, the supply fan motor and drives must be sized to overcome the total system static pressure, including return losses, and pull return air back to the unit during non-economizer operation. However, a supply fan can typically overcome return duct losses more efficiently than a return air fan system. Essentially, one large fan by itself is normally more efficient than two fans in series because of only one drive loss, not two as with return fan systems.

In a return fan system, the return fan is in series with the supply fan, and operates continuously whenever the supply fan is operating to maintain return air volume. The supply fan motor and drives are sized to deliver the design CFM based on internal and discharge static pressure losses only. The return fan motor and drives are sized to pull the return CFM back to the unit based on return duct static. Therefore, with a return fan system, the supply fan ordinarily requires less horsepower than a system with an exhaust fan

Exhaust/Return Systems

- Barometric Relief
- 50 percent exhaust air fan option
- 100 percent modulating exhaust with Statitrac direct space sensing building pressurization control (with or without exhaust variable frequency drives)
- 100 percent modulating exhaust without Statitrac
- 100 percent modulating plenum return airfoil fan with Statitrac direct space sensing building pressurization control with variable frequency drive
- 100 percent modulating plenum return airfoil fan without Statitrac
- Drivers for applying either return or exhaust fan systems range from economy, to building pressure control, to code requirements, to generally accepted engineering practices.

Application Recommendations

Barometric Relief Dampers

Barometric relief dampers consist of gravity dampers which open with increased building pressure. As the building pressure increases, the pressure in the unit return section also increases, opening the dampers and relieving air. Barometric relief may be used to provide relief for single story buildings with no return ductwork and exhaust requirements less than 25 percent.

50 Percent Exhaust System

The 50 percent exhaust system is a single FC exhaust fan with half the air moving capabilities of the supply fan system. It is Trane's experience that a non-modulating exhaust system selected for 40 to 50 percent of nominal supply CFM can be applied successfully. The 50 percent exhaust system generally should not be selected for more than 40 to 50 percent of design supply airflow. Since it is an on/off non-modulating system, it does not vary exhaust CFM with the amount of outside air entering the building. Therefore, if selected for more than 40 to 50 percent of supply airflow, the building may become under-pressurized when economizer operation is allowing lesser amounts of outdoor air into the building. If, however, building pressure is not of a critical nature, the non-modulating exhaust system may be sized for more than 50 percent of design

100 Percent Modulating Exhaust with Statitrac Control, Constant Volume and VAV Units

For both CV and VAV rooftops, the 100 percent modulating exhaust discharge dampers or fan are modulated in response to building pressure. A differential pressure control system, Statitrac, uses a differential pressure transducer to compare indoor building pressure to atmospheric pressure. The FC exhaust fan is turned on when required to lower building static pressure to setpoint. The Statitrac control system then modulates the discharge dampers or fan to control the building pressure to within the adjustable, specified deadband that is set at the Human Interface Panel. Economizer and return air dampers are modulated independent of the exhaust dampers or fan based on ventilation control and economizer cooling requests.

Advantages:

- The exhaust fan runs only when needed to lower building static pressure.
- Statitrac compensates for pressure variations within the building from remote exhaust fans and makeup air units.
- When discharge dampers are utilized to modulate the exhaust airflow, the exhaust fan may be running unloaded whenever the economizer dampers are less than 100 percent open.

The Trane 100 percent modulating exhaust system with Statitrac provides efficient control of building pressure in most applications simply because 100 percent modulating exhaust discharge dampers (or VFD) are controlled directly from building pressure, rather than from an indirect indicator of building pressure, such as outdoor air damper position.

100 Percent Modulating Exhaust System without Statitrac, Constant Volume Units Only

This fan system has performance capabilities equal to the supply fan. The FC exhaust fans are started by the economizer's outdoor air damper position and the exhaust dampers track the economizer outdoor air damper position. The amount of air exhausted by this fan is controlled by modulating discharge dampers at the fan outlet. The discharge damper position is controlled by a signal that varies with the position of the economizer dampers. When the exhaust fans start, the modulating discharge dampers are fully closed, and exhaust airflow is 15 to 20 percent of total exhaust capabilities.

Advantages:

- The exhaust fan runs only when the economizer reaches the desired exhaust enable point.
- Exhaust dampers are modulated based on the economizer position.
- When discharge dampers are utilized to modulate the exhaust airflow, the exhaust fan may be running unloaded whenever the economizer dampers are less than 100 percent open.

The Trane 100 percent modulating exhaust system provides excellent linear control of building exhaust in most applications where maintaining building pressure is not important.

Figure 3. Plan view of modulating 100-percent exhaust system

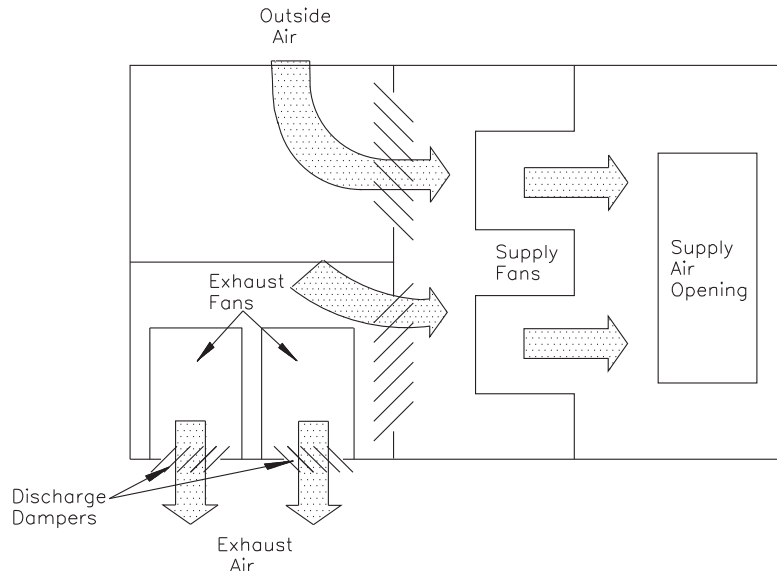

100 Percent Modulating Return Fan Systems with Statitrac Control, Constant Volume and VAV units

For both CV and VAV applications, the IntelliPak™ rooftop unit offers 100 percent modulating return fan systems. A differential pressure control system, Statitrac, uses a differential pressure transducer to compare indoor building pressure to atmospheric pressure. The return fan exhaust dampers are modulated, based on space pressure, to control the building pressure to within the adjustable, specified deadband that is set at the Human Interface Panel. A VFD modulates the return fan speed based on return duct static pressure. Economizer and return air dampers are modulated independent of the exhaust dampers based on ventilation control and economizer cooling requests.

Advantages:

- The return fan operates independently of the supply fan to provide proper balance throughout the airflow envelope.
- Statitrac compensates for pressure variations within the building from remote exhaust fans and makeup air units.
- The return fan acts as both exhaust and return fan based on operation requirements.

The Trane 100 percent modulating return system with Statitrac provides efficient control of building pressure in applications with higher return duct static pressure and applications requiring duct returns. Exhaust discharge dampers are controlled directly from building pressure, return fan VFD is controlled from return static pressure, and return/economizer dampers are controlled based on ventilation control and economizer cooling requests.

100 Percent Modulating Return Fan without Statitrac Control, Constant Volume Units Only

The return fan runs continuously while the supply fan is energized. Economizer, return air, and exhaust dampers are modulated based on ventilation control, and economizer cooling requests.

Advantages:

- The return fan enhances total system static capability.
- The return fan discharges in two directions, thereby balancing exhaust and unit return air volumes.

Horizontal Discharge

Note: Horizontal discharge cannot be applied to units with return fans.

The typical rooftop installation has both the supply and return air paths routed through the roof curb and building roof. However, many rooftop installations require horizontal supply and/or return from the rooftop because of a building's unique design or for acoustic considerations.

Trane has two ways to accomplish horizontal supply and/or return. The first method is through special field supplied curbs that use the unit's standard discharge and return openings. The supply and return air is routed through the curb to horizontal openings on the sides of the curb. The second method available for horizontal supply and return applies to 20 - 75 tons SXHL, SFHL, SLHL, SSSL and 90 - 130 tons SXHK, SLHK and SSHK design units ONLY. With this method the standard discharge and return openings are blocked in the factory as a design special. Access panels are removed as indicated in [Figure 4, p. 24](#). These openings are used for the discharge and return. No special curb is needed.

SXHL, SFHL, SLHL, SSSL Units

[Figure 4](#) is a simplified sketch of the rooftop showing which panels can be used for horizontal supply and/or return. To supply air horizontally, the panels that normally house the heat accessory controls (Panel A) and the gas heat barometric dampers (Panel B) can be removed and either of the openings used as a unit discharge (see note¹). To return air horizontally, the exhaust fan access door (Panel C) can be removed and used as a return opening. [Table 1](#), [Table 2](#) and [Table 3, p. 25](#) show dimensions for those panels (see note⁴).

Horizontal Discharge on SXHL, SFHL, SLHL and SSSL Rooftops (20-75 Ton)

The SXHL (extended casing cooling only), SFHL (gas heat), SSSL (steam heat) and SLHL (hot water heat) rooftops can be factory modified as a design special to supply and return air horizontally without the use of a horizontal supply/return curb.

To supply air horizontally on SXHL only, the panels that normally house the heat accessory controls (Panel A) and the gas heat barometric dampers (Panel B) can be removed and either of the openings used as a unit discharge. To return air horizontally, the exhaust fan access door (Panel C) can be removed and used as a return opening (see note⁴).

Application Considerations

Figure 4. Horizontal discharge panel dimensions – SXHL, SFHL, SLHL, SSSL units (20-75 Ton)

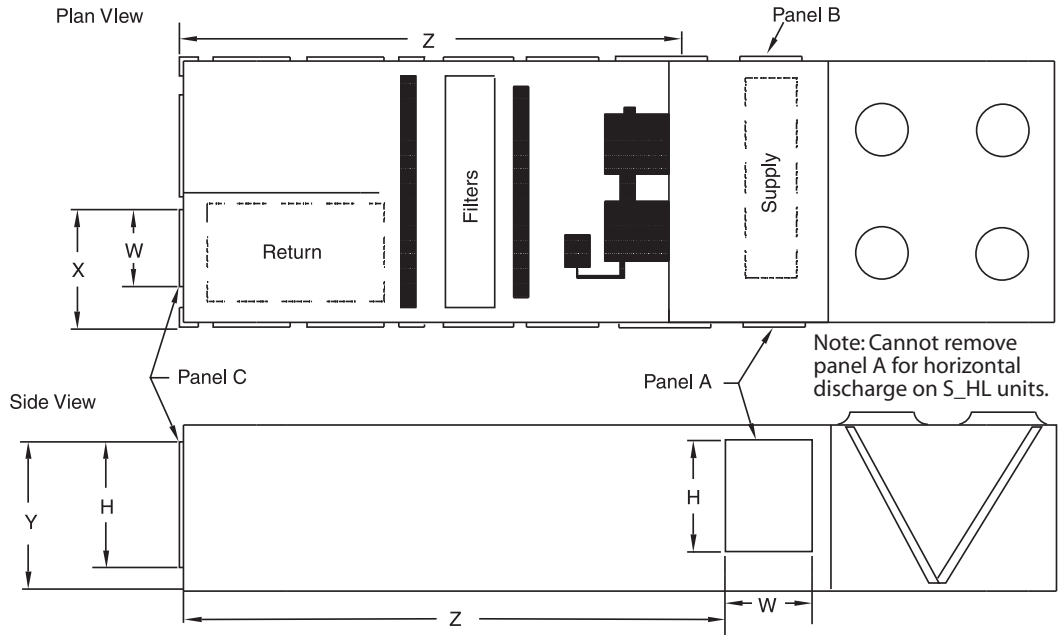

Notes:

1. For horizontal discharge on SFHL, SLHL and SSSL units, only the Panel B can be removed. Panel A cannot be used due to the location of the heating
2. Add an extra 0.20-inches pressure drop to the supply external static to account for the extra turn the air is making.
3. The openings all have a 1.25-inch lip around the perimeter to facilitate ductwork attachment.
4. If exhaust/return fans are being used, provisions should be made for access to the exhaust components, since the access door is now being used as a return.
5. Use the dimensions provided and the supply Cfm to calculate the velocity (ft/min) through the openings to be sure they are acceptable coils.

Table 1. SXHL, SFHL, SSSL, SLHL - Panel A and B dimensions

Model	H (in.)	W (in.)	Total Area (H X W)	
			(in. ²)	(ft ²)
S*HL *20	40.7	25.5	1038	7.2
S*HL *25	40.7	25.5	1038	7.2
S*HL *30	52.7	25.5	1344	9.3
S*HL *40	64.5	34.5	2225	15.5
S*HL *50	76.7	34.5	2646	18.4
S*HL *55	76.7	34.5	2646	18.4
S*HL *60	64.6	34.5	2229	15.5
S*HL *70	64.6	34.5	2229	15.5
S*HL *75	64.6	34.5	2229	15.5

* = Universal letter/number. See model number for specifics.

Table 2. SXHL, SFHL, SSSL, SLHL - Panel C dimensions

Model	H (in.)	W (in.)	Total Area (H X W)	
			(in. ²)	(ft. ²)
S*HL *20	40.7	34.5	1404	9.8
S*HL *25	40.7	34.5	1404	9.8
S*HL *30	52.7	34.5	1818	12.6
S*HL *40	64.5	34.5	2225	15.5
S*HL *50	76.7	34.5	2646	18.4
S*HL *55	76.7	34.5	2646	18.4
S*HL *60	64.6	34.5	2229	15.5
S*HL *70	64.6	34.5	2229	15.5
S*HL *75	64.6	34.5	2229	15.5

* = Universal letter/number. See model number for specifics.

Table 3. SXHL, SFHL, SSSL, SLHL - X, Y and Z dimensions

Model	X (in.)	Y (in.)	Z (in.)
S*HL *20	43.5	44.0	201.5
S*HL *25	43.5	44.0	201.5
S*HL *30	43.5	56.0	201.5
S*HL *40	44.5	67.8	237.0
S*HL *50	44.5	80.0	237.0
S*HL *55	44.5	80.0	237.0
S*HL *60	44.5	68.0	237.5
S*HL *70	44.5	68.0	237.5
S*HL *75	44.5	68.0	237.5

* = Universal letter/number. See model number for specifics.

Horizontal Discharge on 90-130 Ton

Figure 5, p. 26 is a simplified sketch showing which panels can be used for horizontal supply and/or return. On 90 to 130 ton units, only one side of the extended casing may be used for horizontal supply because of the location of the unit control panel. There are, however, two panels on SXHK models (Panels A) on the side opposite the control box which can be removed along with the vertical support which separates the two. Removal of the vertical support is optional, but will ensure maximum airflow. On SLHK, SSK models only one of the Panel A's may be used for horizontal supply because of the location of the heating coil. Horizontal return is accomplished in much the same way as on S*HLs by removing the exhaust fan access door (Panel B). See Table 4 and Table 5 for S*HK panel dimensions (see note 4).

When using an IntelliPak™ Rooftop for horizontal supply and return, an additional pressure drop must be added to the supply external static to account for the 90 degree turn the air is making. This additional pressure drop depends on airflow and rooftop size, but a range of 0.10 inches to 0.30 inches can be expected. The openings on the rooftop all have a one inch lip around the perimeter to facilitate ductwork attachment. If exhaust/return fans are being used on an IntelliPak™ Rooftop unit with horizontal return, provisions should be made for access to the exhaust components, since the access door opening is now being used as a return. Perhaps the return ductwork attachment to the rooftop can include a section of removable duct. Use the dimensions provided and the supply and exhaust CFM to calculate the velocity (ft./min) through the openings.

Application Considerations

Figure 5. Horizontal discharge panel dimensions – 90-130 tons SXHK, SLHK, SSHK, units

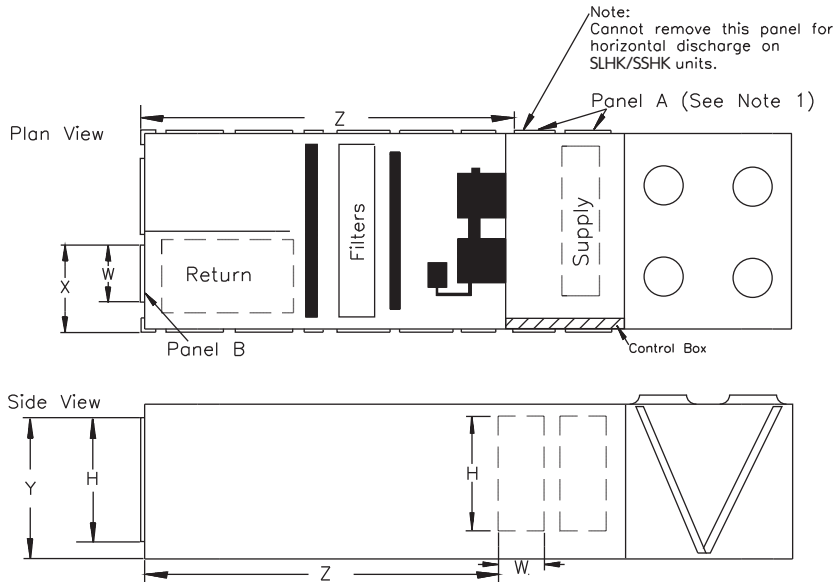

Table 4. SXHK, SLHK, SSHK - Panel A and B dimensions

Panel	H (in.)	W (in.)	Total Area (H X W)	
			(in. ²)	(ft ²)
A	72.7	27.5	1999	13.9
B	72.7	32.0	2508	17.4

Table 5. SXHK, SLHK, SSHK - X, Y and Z dimensions

Model	X (in.)	Y (in.)	Z (in.)
S*HK 90-130	69.0	77.8	244.7

* = X, L, or S

Note:

1. SXHK units have two Panel A's that can be removed. Once unit is installed, panel(s) and the 6 1/2" vertical support channel in between may be removed.
2. Add an extra 0.20-inches pressure drop to the supply external static to account for the extra turn the air is making.
3. The openings all have a 1.25-inch lip around the perimeter to facilitate ductwork attachment.
4. If exhaust/return fans are being used, provisions should be made for access to the exhaust components, since the access door is now being used as a return.
5. Use the dimensions provided and the supply Cfm to calculate the velocity (ft/min) through the openings to be sure they are acceptable.

Horizontal Discharge SXHK, SLHK, SSHK Rooftops (90 to 130 tons)

The SXHK, SLHK, SSHK rooftops can be factory modified as a design special to supply and return air horizontally without the use of a horizontal supply/return curb.

To supply air horizontally, use Panel A only. The Panel on the opposite side cannot be used due to the location of the unit control Panel. SXHK rooftop air conditioners do not have a panel configuration like the 20-89 ton rooftops. To achieve maximum airflow, vertical support can be removed after the unit has been placed on the roof curb. It is secured by four screws. (See note 1.) For horizontal discharge on SLHK and SSHK units, only the Panel A next to the condenser fan section can be removed. The other Panel A next to the supply fan cannot be used due to the location of the heating coils.

To return air horizontally, the exhaust fan access door (Panel B) can be removed and used as a return opening (see note 4.).

Capacity/Efficiency Options

High Capacity

Rooftops are popular because of their "packaged" nature. Everything needed is contained in one box; mix-matching is neither necessary nor available. With this convenience comes some disadvantages; one is the rooftop's cooling capacity may not exactly match the building load. It is conceivable that a 50 ton rooftop would need to be used on an application that is 41 tons, simply because the 40 ton rooftop does not meet capacity.

In order to avoid such occurrences, and to more closely match the rooftop's capacity to the building load, a high capacity option is available on all IntelliPak™ Rooftops. On 40-75 ton units, this high capacity option has larger compressors that provide higher refrigerant mass flow rates, resulting in a higher capacity. The 90 ton unit has the option of a high capacity evaporator with an added high efficiency condenser coil. The 105 ton is only available with a high capacity evaporator coil. Capacity tables for both standard and high capacity units are available in the cooling data section of this catalog. See [Table 55, p. 106](#) for the pressure drops associated with the high capacity coil option on the 90 and 105 ton. This pressure drop should be added to the total static pressure used to size the supply fan motor.

High Efficiency Units

Trane offers a high-efficiency option for 20-75 ton units. This option is especially helpful in meeting high efficiency requirements legislated by some states as well as qualifying for local utility rebates. High efficiency units meet CEE Tier 2 requirements.

High Efficiency Air-Cooled Condenser Coil

The 90 ton unit can also be optionally equipped with an increased number of condenser coil rows to enhance the rooftop capacity and efficiency. This option is especially helpful to meet the high efficiency requirements legislated by some states and to qualify for local utility rebates. Capacity tables for both standard and high efficiency condenser coils are available in the cooling data section of this catalog.

Supply Fan Options

Trane offers two types of supply fans as options for 20-75 ton units. These units may be ordered with a traditional belt-driven, forward-curved (FC) fan or with a direct-drive plenum (DDP) fan. The DDP fans offer multiple width options to optimize fan efficiency for the system design point. Depending on design points, a DDP fan may offer an efficiency gain for the unit. DDP fans offer increased reliability and require less maintenance than FC fans because there are no belts to tension or replace, no bearings to grease, and no sheaves to align. See Trane's engineering bulletin on DDP fans (RT-PRB033-EN) for more application details.

Miscellaneous Applications

Low Ambient Operation - Human Interface Recommendations

Who wants to be on a roof at subzero temperatures? We can understand a service technician's reluctance to do this; that's why we offer a remote mounted Human Interface Panel. The service technician can troubleshoot and diagnose in the comfort of a mechanical room.

IntelliPak™ Replacement Unit (IRU)

This option must be included when replacing an existing R-22 IntelliPak™ unit with the current R-410A design and is also applied when using a full perimeter curb with isolation. The IntelliPak™ Rooftop Replacement Engineering bulletin RT-PRB027-EN provides more detail on this.

Corrosive Atmospheres

Trane's IntelliPak™ Rooftops are designed and built to industrial standards and will perform to those standards for an extended period depending on the hours of use, the quality of maintenance performed, and the regularity of that maintenance. One factor that can have an adverse effect on

Application Considerations

unit life is its operation in a corrosive environment. Since the Microchannel condenser coil is an all-aluminum design, it provides a high level of corrosion protection on its own. Uncoated, it withstands a salt spray test in accordance with ASTM B117 for 1,000 hours. When rooftops are operated in highly corrosive environments, Trane recommends the corrosion protected condenser coil option.

This corrosion protection option meets the most stringent testing in the industry, including ASTM B117 Salt Spray test for 6,000 hours and ASTM G85 A2 Cyclic Acidified Salt Fog test for 2,400 hours. The acid fog test is the most stringent available today. This coating is added after coil construction covering all tubes, headers, fins and edges. The design provides superior protection from any corrosive agent. For evaporator coils, copper fins can be utilized as a design special.

Note: *Field coating is not allowed on Microchannel coils.*

Ventilation Override Sequences

One of the benefits of using an exhaust system is that the rooftop can be used as part of a ventilation override system. Several types of sequences can be easily done when power exhaust is a part of the rooftop system. What would initiate the ventilation override control sequence? Typically, a manual switch is used and located near the fire protection control panel. This enables the fire department access to the control for use during or after a fire. It is also possible to initiate the sequence from a field-installed automatic smoke detector. In either case, a contact closure begins the ventilation override control sequence.

Important: *The ventilation override system should not be used to signal the presence of smoke caused by a fire.*

Trane can provide five (5) different ventilation override sequences on both CV and VAV IntelliPak™ Rooftops. For your convenience the sequences can be factory preset or fully field editable from the Human Interface Panel or Tracer™. Any or all five sequences may be "locked" in by the user at the Human Interface Panel. The user can customize up to five (5) different override sequences for purposes such as smoke control. The following parameters within the unit can be defined for each of the five sequences:

- Supply Fan - on/off
- Variable Frequency Drives - on (60 Hz)/off (0 Hz)/controlling
- Exhaust/Return Fan - on/off
- Exhaust Dampers - open/closed
- Economizer dampers - open/closed
- Heat - off/controlling (output for) VAV Boxes - open/controlling

Compressors and condenser fans are shut down for any Ventilation Override sequence. Factory preset sequences include unit Off, Exhaust, Purge, Purge with duct pressure control, and Pressurization. Any of the user-defined Ventilation Override sequences can be initiated by closing a field supplied switch or contacts connected to an input on the Ventilation Override Module. If more than one ventilation override sequence is being requested, the sequence with the highest priority is initiated. Refer to the Sequence of Operation provided in the Control section of this catalog for more details on each override sequence.

Natural Gas Heating Considerations

The IntelliPak™ standard, or limited modulation, gas heat exchangers are not recommended for applications with mixed air conditions entering the heat exchanger below 50°F. Mixed air temperatures below 50°F can cause condensation to form on the heat exchanger, leading to premature failure. For increased reliability, the recommendation in these applications is full modulation gas heat. For airflow limitations and temperature rise across the heat exchanger information, see [Table 46, p. 82](#) and [Table 48, p. 82](#).

Acoustical Considerations

The ideal time to make provisions to reduce sound transmission to the space is during the project design phase. Proper placement of rooftop equipment is critical to reducing transmitted sound

levels to the building. The most economical means of avoiding an acoustical problem is to place any rooftop equipment away from acoustically critical area. If possible, rooftop equipment should not be located directly above areas such as: offices, conference rooms, executive office areas and classrooms. Ideal locations are above corridors, utility rooms, toilet facilities, or other areas where higher sound levels are acceptable.

Several basic guidelines for unit placement should be followed to minimize sound transmission through the building structure:

1. Never cantilever the condensing section of the unit. A structural cross member must support this end of the unit.
2. Locate the unit's center of gravity close to or over a column or main support beam to minimize roof deflection and vibratory noise.
3. If the roof structure is very light, roof joists should be replaced by a structural shape in the critical areas described above.
4. If several units are to be placed on one span, they should be staggered to reduce deflection over that span.

It is impossible to totally quantify the effect of building structure on sound transmission, since this depends on the response of the roof and building members to the sound and vibration of the unit components. However, the guidelines listed above are experience proven guidelines which will help reduce sound transmission.

There are several other sources of unit sound, i.e., supply fan, compressors, exhaust fans, condenser fans and aerodynamic noise generated at the duct fittings. Refer to the current ASHRAE Applications Handbook for guidelines on minimizing the generation of aerodynamic noise associated with duct fittings.

For information on various duct installation considerations specifically addressing indoor sound level concerns, see the latest Trane Engineering bulletin on sound. This bulletin includes sound power data on Trane's IntelliPak™ Rooftops. Contact your local Trane representative for this bulletin.

The VariTrane™ Duct Design Program can be used to analyze the truck duct, run-out duct, VAV control unit and terminal unit noise attenuation. This program quantifies the airborne sound generation that can be expected in each terminal so that the designer can identify potential sound problems and make design alterations before equipment installation.

The Trane Acoustics Program (TAP) allows modeling of rooftop installation parameters. The output of this program shows the resulting indoor NC level for the modeled installation. This program is available from Trane's Customer Direct Service Network (CDS), ask your local Trane representative for additional information on this program.

Application Considerations

Clearance Requirements

The recommended clearances identified with unit dimensions should be maintained to assure adequate serviceability, maximum capacity and peak operating efficiency.

A reduction in unit clearance could result in condenser coil starvation or warm condenser air recirculation. Clearances must be considered for the following:

- Do the clearances available allow for major service work such as changing compressors or coils?
- Do the clearances available allow for proper outside air intake, exhaust air removal and condenser airflow?
- If screening around the unit is being used, is there a possibility of air recirculation from the exhaust to the outside air intake or from condenser exhaust to condenser intake?
- Do clearances meet all applicable codes?

Actual clearances which appear inadequate should be reviewed with a local Trane sales engineer. When two or more units are to be placed side by side, the distance between the units should be increased to 150 percent of the recommended single unit clearance. The units should also be staggered as shown in [Figure 6](#) for two reasons:

1. To reduce span deflection if more than one unit is placed on a single span. Reducing deflection discourages sound transmission.
2. To assure proper diffusion of exhaust air before contact with the outside air intake of adjacent unit.

Figure 6. Unit placement

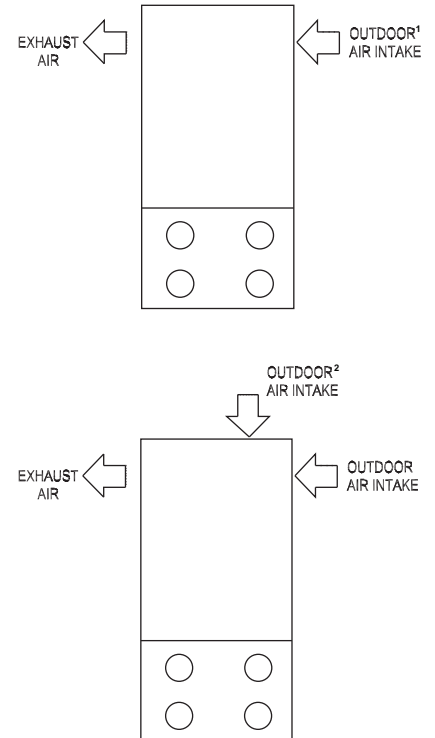

1. 20-40 ton air-cooled models have only one outdoor air intake. 50-75 ton air-cooled models have two outdoor air intakes.
2. 90-130 ton models have two outdoor air intakes on the backside of the unit and one small air intake at the end of the unit.

Selection Procedure

Air-Cooled Rooftop

This section outlines a step-by-step procedure that may be used to select a Trane air-cooled single-zone air conditioner. Air-cooled models should be selected based on dry bulb (DB) conditions. For specific model selection, utilize TOPSS™ computer software selection program or contact the local Trane Sales Office. The sample selection is based on the following conditions:

Note: *When calculating capacities for evaporative condensers, use ambient wet bulb (WB).*

- Summer outdoor design conditions - 95 DB/76 WB ambient temperature
- Summer room design conditions - 78 DB/64 WB
- Total cooling load - 430 MBh (35.8 tons)
- Sensible cooling load - 345 MBh (28.8 tons)
- Outdoor air ventilation load - 66.9 MBh
- Return air temperature - 80 DB/65 WB

Winter Design:

- Winter outdoor design conditions - 0°F
- Return air temperature - 70°F
- Total heating load - 475 MBh
- Winter outdoor air ventilation load - 133 MBh

Air Delivery Data:

- Supply fan CFM - 17,500 CFM
- External static pressure - 1.2 in wg
- Minimum outdoor air ventilation - 1,750 CFM
- Exhaust/Return fan CFM - 12,000 CFM
- Return air duct negative static pressure - 0.65 in wg

Electrical Characteristics:

- Voltage/cycle/phase - 460/60/3 Unit Accessories:
- Gas fired heat exchanger - high heat module
- Throwaway filters
- Economizer
- Modulating 100 percent exhaust/return fan

Cooling Capacity Selection

Step 1 - Nominal Unit Size Selection

A summation of the peak cooling load and the outside air ventilation load shows: 430 MBh + 66.9 MBh = 496.9 MBh required unit capacity. From [Table 24, p. 60](#), a 50 ton unit capacity with standard capacity evaporator coil at 80 DB/65 WB, 95°F outdoor air temperature and 17,500 total supply CFM is 581 MBh total and 430 MBh sensible. Thus, a nominal 50 ton unit with standard capacity is selected.

Step 2 - Evaporator Coil Entering Conditions

Mixed air dry bulb temperature determination:

Using the minimum percent of OA (1,750 CFM ÷ 17,500 CFM = 10 percent), determine the mixture dry bulb to the evaporator.

$$\text{RADB} + \% \text{ OA (OADB - RADB)} = 80 + (0.10) (95 - 80) = 80 + 1.5 = 81.5^\circ\text{F}$$

Approximate wet bulb mixture temperature:

$$\text{RAWB} + \% \text{ OA (OAWB - RAWB)} = 65 + (0.10) (76 - 65) = 65 + 1.1 = 66.1^\circ\text{F}$$

Selection Procedure

Step 3 - Determine Supply Fan Motor Heat Gain

Having selected a nominal 50 ton unit, the supply fan bhp can be calculated. The supply fan motor heat gain must be considered in final determination of unit capacity.

Supply Air Fan

Determine unit total static pressure (see Table 54, p. 105) at design supply CFM:

External Static Pressure	1.2 inches
Evaporator Coil	0.57 inches
Return Duct Negative Static Pressure	0.65 inches
Heat Exchanger	0.31 inches
Throwaway Filter	0.10 inches
Economizer w/Exhaust Fan	0.12 inches
Trane Roof Curb	0.13 inches
Unit Total Static Pressure	3.22 inches

Using total of 17,500 CFM and total static pressure of 3.22 inches, estimate the bhp and rpm using the fan curve in Figure 15, p. 92 for an FC fan. The bhp is 18.2 at 993 rpm. Similarly, a DDP fan can be selected using Figure 19, p. 96 or Figure 20, p. 97.

From Figure 7, p. 33 supply fan motor heat gain = 51.9 MBh.

Step 4 - Determine Total Required Cooling Capacity

Required capacity = Total peak load + OA load + supply air fan motor heat.

Required capacity = 430 + 66.9 + 51.9 = 548.8 MBh (45.7 tons)

Step 5 - Determine Unit Capacity

From Table 24, p. 60, unit capacity at 81.5 DB/66.1 WB entering the evaporator, 17,500 supply air CFM, 95°F outdoor ambient, is 575 MBh (47.9 tons) with 475 MBh sensible.

Step 6 - Determine Leaving Air Temperature

Unit sensible heat capacity corrected for supply air fan motor heat = 475 MBh - 51.9 MBh = 423 MBh.

Supply air dry bulb temperature difference =

$$\frac{\text{Sensible Btu}}{1.085 \times \text{Supply CFM}} =$$

$$423 \text{ MBh} \div (1.085 \times 17,500 \text{ CFM}) = 22.3^\circ\text{F}$$

$$\text{Supply air dry bulb} = 81.5 \text{ DB} - 22.3 = 59.2^\circ\text{F}$$

Unit enthalpy difference =

$$\frac{\text{Total Btu}}{4.5 \times \text{Supply CFM}} =$$

$$575 \text{ MBh} \div (4.5 \times 17,500 \text{ CFM}) = 7.3 \text{ Btu/lb}$$

$$\text{Leaving enthalpy} = h(\text{ent WB}) - h(\text{diff}). \text{ From Table 11, p. 48 } h(\text{ent WB}) = 30.9 \text{ Btu/lb}$$

$$\text{Leaving enthalpy} = 30.9 \text{ Btu/lb} - 7.3 \text{ Btu/lb} = 23.6 \text{ Btu/lb}$$

$$\text{Supply air wet bulb} = 55.6$$

$$\text{Leaving air temperature} = 59.2 \text{ DB}/55.6 \text{ WB}$$

Heating Capacity Selection

Step 1 - Determine Air Temperature Entering Heating Module

Mixed air temperature = $RADB + \% OA (OADB - RADB) = 70 + (0.10) (0 - 70) = 63^{\circ}F$

Supply air fan motor heat temperature rise = $51,900 \text{ Btu} \div (1.085 \times 17,500 \text{ CFM}) = 2.73^{\circ}F$

Air temperature entering heating module = $63.0 + 2.73 = 65.7^{\circ}F$

Step 2 - Determine Total Winter Heating Load

Total winter heating load = peak heating load + ventilation load - supply fan motor heat = $475 + 133 - 51.9 = 556.1 \text{ MBh}$

Electric Heating System

Unit operating on 460/60/3 power supply.

From [Table 52, p. 84](#), kW may be selected for a nominal 50 ton unit operating 460-volt power. The 170 kW heat module (580.1 MBh) will satisfy the winter heating load of 563 MBh.

[Table 50, p. 83](#) shows an air temperature rise of $30.6^{\circ}F$ for 17,500 CFM through the 170 kW heat module.

Unit supply temperature at design heating conditions = mixed air temperature + air temperature rise = $65.7^{\circ}F + 30.6^{\circ}F = 96.3^{\circ}F$

Gas Heating System (Natural Gas)

From [Table 46, p. 82](#) select the high heat module (697 MBh output) to satisfy winter heating load of 563 MBh at unit CFM.

[Table 46, p. 82](#) also shows an air temperature rise of $36.0^{\circ}F$ for 17,500 CFM through the heating module.

Unit supply temperature at design heating conditions = mixed air temperature + air temperature rise = $65.7^{\circ}F + 36.0^{\circ}F = 101.7^{\circ}F$

Figure 7. Fan motor

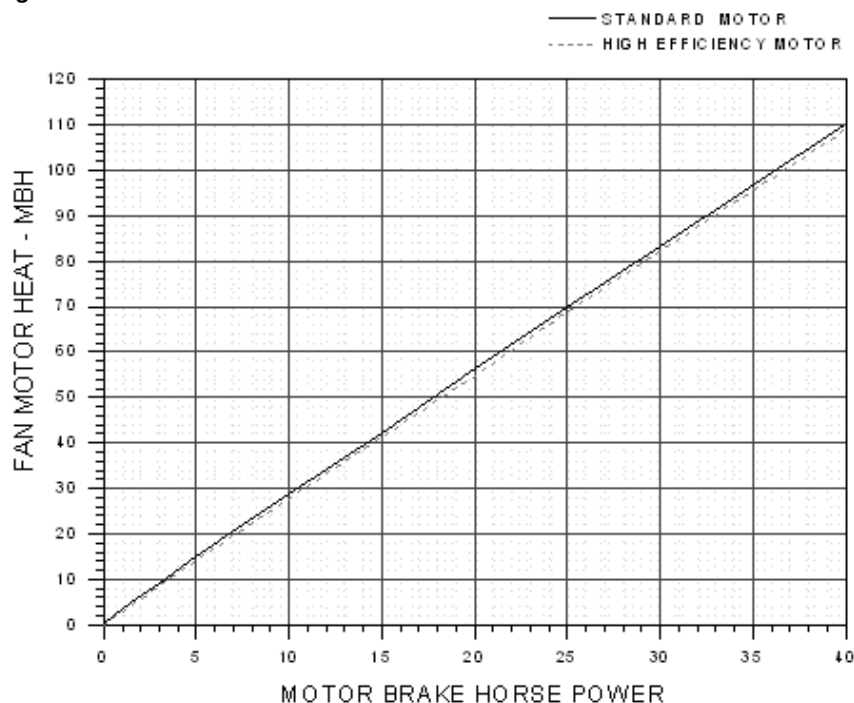

Selection Procedure

Hot Water Heating

Assume a hot water supply temperature of 190°F. Subtract the mixed air temperature from the hot water temperature to determine the ITD (initial temperature difference).

ITD = 190°F - 65.7°F = 126°F. Divide the winter heating load by ITD = 563 MBh ÷ 126°F = 4.50 Q/ITD.

From [Table 53, p. 84](#), select the low heat module. By interpolation, a Q/ITD of 4.50 can be obtained at a gpm at 25.7.

Water pressure drop at 25.7 gpm is 0.57 ft. of water. Heat module temperature rise is determined by:

$$\frac{\text{Total Btu}}{1.085 \times \text{Supply CFM}} = \Delta T$$

$$\frac{563,000}{(1.085 \times 17,500)} = 29.7^\circ\text{F}$$

Unit supply air temperature = mixed air temperature + air temperature rise = 65.7 + 29.7 = 95°F.

Steam Heating System

Assume a 15 psig steam supply.

From [Table 49, p. 83](#), the saturated temperature steam is 250°F. Subtract mixed air temperature from the steam temperature to determine ITD. ITD = 250°F - 65.7°F = 186°F.

Divide winter heating load by ITD = 563 MBh ÷ 186°F = 3.03 Q/ITD.

From [Table 48, p. 82](#), select the high heat module. The high heat module at 17,500 CFM has a Q/ITD = 5.11.

Heat module capacity, Q = ITD × Q/ITD = 186 F × 5.11 Q/ITD = 950 MBh

Heat module air temperature rise

$$= \frac{\text{Total Btu}}{1.085 \times \text{Supply CFM}}$$

945 Btu ÷ (1.085 × 17,500 CFM) = 50°F.

Unit supply temperature at design conditions = mixed air temperature + air temperature rise = 65.1°F + 50°F = 116°F.

Air Delivery Procedure

Supply fan performance curves include internal resistance of rooftop. For total static pressure determination, system external static must be added to appropriate component static pressure drop (evaporator coil, filters, optional economizer, optional exhaust fan, optional heating system, optional cooling only extended casing, optional roof curb).

Supply Fan Motor Sizing

The supply fan motor selected in the cooling capacity determination was 18.2 bhp and 993 rpm. Thus, a 20 hp supply fan motor is selected. For an FC fan selection, enter [Table 64, p. 111](#) to select the proper drive. For a 50 ton rooftop with 20 hp motor, a drive number A - 1000 rpm is selected.

Exhaust Fan Motor Sizing

The exhaust fan is selected based on total return system negative static pressure and exhaust fan CFM. Return system negative static include return duct static and roof curb static pressure drop.

Return duct static pressure = 0.65 inches

Trane roof curb ([Table 54, p. 105](#)) = 0.12 inches

Total return system negative static pressure = 0.77 inches

Exhaust fan CFM = 12,000 CFM

From [Table 72, p. 137](#), the required bhp is 3.45 hp at 574 rpm. Thus, the exhaust fan motor selected is 5 hp.

To select a drive, enter [Table 62, p. 110](#) for a 5 hp motor for a 50 ton unit. Drive selection number 6 - 600 rpm.

Where altitudes are significantly above sea level, use [Table 12, p. 49](#), and [Table 13, p. 49](#) and [Figure 8, p. 49](#) for applicable correction factors.

Return Fan Motor Sizing

The return fan is selected based on the return fan CFM and the total return system negative static pressure. The return system negative static includes the return duct static, the exhaust damper pressure drop, and any roof curb static pressure drop.

Since return fans handle all of the return static, supply fan motor sizing does not need to include this value. This feature is helpful if the supply motor HP is over the maximum limit and in some cases, can allow supply motor downsizing.

However, since the return fan runs continuously to handle all of the return static, the sensible heat generated by the motor must be included in the entering evaporator coil mixed temperature equation.

Return Duct Static Pressure = 0.65

Roof curb Static Pressure ([Table 54, p. 105](#)) = 0.12

Exhaust Damper Pressure Drop = 0.41

Total Return System Static Pressure = 1.18

Return Fan CFM = 12000

From [Table 67, p. 113](#), the required bhp is 4.55. Thus the return fan is selected at 5HP. To select a drive, look at [Table 70, p. 116](#) for a 5HP return motor on a 50 HP unit. Drive selection number C - 1200.

Using [Figure 7, p. 33](#) for fan motor heat, motor heat for 4.55 BHP = 10.4 MBH

$10.4 \text{ MBH} / (1.085 \times 12000 \text{ return fan CFM}) = 0.80^\circ\text{F}$

0.80°F is added to the return air temperature

Hot Gas Reheat

Hot Gas Reheat Dehumidification Selection

The hot gas reheat option allows for increased outdoor air ventilation. It reduces humidity levels while increasing comfort level in the air space.

Note: Please note that hot gas reheat operation will not be allowed when there is a call for heat or a more than a 50% call for cooling.

Utilize the TOPSS™ selection program or contact a local Trane sales office to calculate leaving unit air temperature, latent capacity, reheat sensible capacity, leaving unit dew point, and moisture removal when the unit is in hot gas reheat operation.

The hot gas reheat TOPSS™ selection requires the following customer input values: supply fan airflow, ambient air temperatures, entering air temperatures, and a desired reheat set point temperature. If the conditions provided are not within the reheat operating envelope an error will be generated in the TOPSS™ program.

If the reheat set point is not obtainable at the provided conditions the customer will be required to make adjustments to the conditions or change the reheat set point value.

Unit Electrical Requirements

Selection procedures for electrical requirements for wire sizing amps, maximum fuse sizing, and dual element fuses are given in the electrical service section of this catalog.

Altitude Corrections

The rooftop performance tables and curves of this catalog are based on standard air (.075 lbs/ft). If the rooftop airflow requirements are at other than standard conditions (sea level), an air density correction is needed to project accurate unit performance.

Figure 8, p. 49 shows the air density ratio at various temperatures and elevations. Trane rooftops are designed to operate between 40 and 90 degrees Fahrenheit leaving air temperature.

The procedure to use when selecting a supply or exhaust fan on a rooftop for elevations and temperatures other than standard is as follows:

1. First, determine the air density ratio using Figure 8.
2. Divide the static pressure at the nonstandard condition by the air density ratio to obtain the corrected static pressure.
3. Use the actual CFM and the corrected static pressure to determine the fan rpm and bhp from the rooftop performance tables or curves.
4. The fan rpm is correct as selected.
5. Bhp must be multiplied by the air density ratio to obtain the actual operating bhp.

In order to better illustrate this procedure, the following example is used:

Consider a 60 ton rooftop unit that is to deliver 18,000 actual CFM at 3-inches total static pressure (tsp), 55°F leaving air temperature, at an elevation of 5,000 ft.

1. From Figure 8, the air density ratio is 0.86.
2. $Tsp = 3.0\text{-inches} / 0.86 = 3.49\text{ inches tsp}$.
3. From the performance tables: a 60 ton rooftop will deliver 18,000 CFM at 3.49-inches tsp at 992 rpm and 26.1 bhp.
4. The rpm is correct as selected - 906 rpm.
5. $Bhp = 26.1 \times 0.86 = 22.4\text{ bhp actual}$.

Compressor MBh, SHR, and kW should be calculated at standard and then converted to actual using the correction factors in Table 12, p. 49. Apply these factors to the capacities selected at standard CFM so as to correct for the reduced mass flow rate across the condenser.

Heat selections other than gas heat will not be affected by altitude. Nominal gas capacity (output) should be multiplied by the factors given in Table 13, p. 49 before calculating the heating supply air temperature.

Model Number Descriptions

S A H L * 5 0 4 0 A 6 8 A 6 B D 8 0 0 1 0 0 W 0 0 G 0 B 0 0 0 R 0 0 0 8 0 0
1 2 3 4 5 6 7 8 9 10 11 12 13 14 15 16 17 18 19 20 21 22 23 24 25 26 27 28 29 30 31 32 33 34 35 36 37 38

DIGIT 1 - UNIT TYPE

S = Self-Contained (Packaged Rooftop)

DIGIT 2 - UNIT FUNCTION

A = DX Cooling, No Heat
 E = DX Cooling, Electric Heat
 F = DX Cooling, Natural Gas Heat
 L = DX Cooling, Hot Water Heat
 S = DX Cooling, Steam Heat
 X = DX Cooling, No Heat, Extended Casing

DIGIT 3 - UNIT AIRFLOW

H = Single Zone

DIGIT 4 - DEVELOPMENT SEQUENCE

L = Sixth

DIGITS 5,6,7 - NOMINAL CAPACITY

*20 = 20 Tons Air-Cooled
 *25 = 25 Tons Air-Cooled
 *30 = 30 Tons Air-Cooled
 *40 = 40 Tons Air-Cooled
 *50 = 50 Tons Air-Cooled
 *55 = 55 Tons Air-Cooled
 *60 = 60 Tons Air-Cooled
 *70 = 70 Tons Air-Cooled
 *75 = 75 Tons Air-Cooled
 *24 = 24 Tons Evap Condenser
 *29 = 29 Tons Evap Condenser
 *36 = 36 Tons Evap Condenser
 *48 = 48 Tons Evap Condenser
 *59 = 59 Tons Evap Condenser
 *73 = 73 Tons Evap Condenser
 *80 = 80 Tons Evap Condenser
 *89 = 89 Tons Evap Condenser

DIGIT 8 - POWER SUPPLY

4 = 460/60/3 XL E = 200/60/3 XL
 5 = 575/60/3 XL F = 230/60/3 XL

Note: SEHL units (units with electric heat) utilizing 208V or 230V require dual power source.

DIGIT 9 - HEATING CAPACITY

Note: When the second digit calls for "F" (Gas Heat), the following values apply: (please note G and M are available ONLY on 50 ton models and above.

G = Low Heat-Limited Modulation
 H = High Heat-2-Stage
 J = High Heat-Limited
 L = Low Heat-2-Stage
 M = Low Heat- Full Modulation
 O = No Heat
 P = High Heat-Full Modulation

Note: When the second digit calls for "E" (electric heat), the following values apply:

D = 30 kW R = 130 kW
 H = 50 kW U = 150 kW
 L = 70 kW V = 170 kW
 N = 90 kW W = 190 kW
 Q = 110 kW

Note: When the second digit calls for "L" (Hot Water) or "S" (Steam) Heat, one of the following valve size values must be in Digit 9:

High Heat Coil:

1 = .50" 2 = .75" 3 = 1"
 4 = 1.25" 5 = 1.5" 6 = 2"

Low Heat Coil:

A = .50" B = .75" C = 1"
 D = 1.25" E = 1.5" F = 2"

DIGIT 10 - DESIGN SEQUENCE

A = First (Factory Assigned)

Note: Sequence may be any letter A thru Z, or any digit 1 thru 9.

DIGIT 11 - EXHAUST/RETURN OPTION

0 = None
 1 = Barometric
 3 = 100% Exhaust 3 HP w/Statitrac
 4 = 100% Exhaust 5 HP w/Statitrac
 5 = 100% Exhaust 7.5 HP w/Statitrac
 6 = 100% Exhaust 10 HP w/Statitrac
 7 = 100% Exhaust 15 HP w/Statitrac
 8 = 100% Exhaust 20 HP w/Statitrac
 B = 50% Exhaust 3 HP
 C = 50% Exhaust 5 HP
 D = 50% Exhaust 7.5 HP
 F = 100% Exhaust 3 HP w/o Statitrac (CV Only)
 G = 100% Exhaust 5 HP w/o Statitrac (CV Only)
 H = 100% Exhaust 7.5 HP w/o Statitrac (CV Only)
 J = 100% Exhaust 10 HP w/o Statitrac (CV Only)
 K = 100% Exhaust 15 HP w/o Statitrac (CV Only)
 L = 100% Exhaust 20 HP w/o Statitrac (CV Only)
 9 = 100% Return 3 HP w/Statitrac
 M = 100% Return 5 HP w/Statitrac
 N = 100% Return 7.5 HP w/Statitrac
 P = 100% Return 10 HP w/Statitrac
 R = 100% Return 15 HP w/Statitrac
 T = 100% Return 20 HP w/Statitrac

U = 100% Return 3 HP w/o Statitrac (CV Only)
 V = 100% Return 5 HP w/o Statitrac (CV Only)
 W = 100% Return 7.5 HP w/o Statitrac (CV Only)
 X = 100% Return 10 HP w/o Statitrac (CV Only)
 Y = 100% Return 15 HP w/o Statitrac (CV Only)
 Z = 100% Return 20 HP w/o Statitrac (CV Only)

DIGIT 12 - EXHAUST/RETURN AIR FAN DRIVE

(Exhaust/Return Fan)

0 = None 8 = 800 RPM
 4 = 400 RPM 9 = 900 RPM
 5 = 500 RPM A = 1000 RPM
 6 = 600 RPM B = 1100 RPM
 7 = 700 RPM
 (Return Fan only)
 C = 1200 RPM H = 1700 RPM
 D = 1300 RPM J = 1800 RPM
 E = 1400 RPM K = 1900 RPM
 F = 1500 RPM
 G = 1600 RPM

DIGIT 13 - FILTER (PRE DX/FINAL)

A = Throwaway
 B = Cleanable Wire Mesh
 C = High-Efficiency Throwaway
 D = Bag With Prefilter
 E = Cartridge with Prefilter
 F = Throwaway Filter Rack (Filter Not Included)
 G = Bag Filter Rack (Filter Not Included)
 H = Standard Throwaway Filter/ Cartridge Final Filters
 J = High Efficiency Throwaway Filter/ Cartridge Final Filters
 K = Bag Filters with 2" Throwaway Prefilters/Cartridge Final Filters
 L = Cartridge Filters with 2" Throwaway Prefilters /Cartridge Final Filters
 M = Standard Throwaway Filter /Cartridge Final Filters with 2" Throwaway Prefilters
 N = High Efficiency Throwaway Filters/ Cartridge Final Filters with 2" Throwaway Prefilters
 P = Bag Filters with Prefilters /Cartridge Final Filters with 2" Throwaway Prefilters
 Q = Cartridge Filters with Prefilters/ Cartridge Final Filters with 2" Throwaway Prefilters

DIGIT 14 - SUPPLY AIR FAN HP

1 = 3 HP FC
 2 = 5 HP FC



Model Number Descriptions

- 3 = 7.5 HP FC
- 4 = 10 HP FC
- 5 = 15 HP FC
- 6 = 20 HP FC
- 7 = 25 HP FC
- 8 = 30 HP FC
- 9 = 40 HP FC
- A = 50 HP FC
- B = 3 HP DDP 80W
- C = 3 HP DDP 120W
- D = 5 HP DDP 80W
- E = 5 HP DDP 120W
- F = 7.5 HP DDP 80W
- G = 7.5 HP DDP 120W
- H = 10 HP DDP 80W (60-89T = 2 x 5 HP)
- J = 10 HP DDP 120W (60-89T = 2 x 5 HP)
- K = 15 HP DDP 80W (60-89T = 2 x 7.5 HP)
- L = 15 HP DDP 120W (60-89T = 2 x 7.5 HP)
- M = 20 HP DDP 80W (60-89T = 2 x 10 HP)
- N = 20 HP DDP 120W (60-89T = 2 x 10 HP)
- P = 25 HP DDP 80W
- R = 25 HP DDP 120W
- T = 30 HP DDP 80W (60-89T = 2 x 15 HP)
- U = 30 HP DDP 120W (60-89T = 2 x 15 HP)
- V = 40 HP DDP 80W(60-89T = 2 x 20 HP)
- W = 40 HP DDP 120W (60-89T = 2 x 20 HP)
- X = 50 HP DDP 80W(70 & 75-89T = 2 x 25 HP)
- Y = 50 HP DDP 120W (70 & 75-89T = 2 x 25 HP)
- Z = 30 HP DDP 100W^(a)

(a) 50, 55T only

DIGIT 15 - SUPPLY AIR FAN RPM

- 4 = 400 RPM
- 5 = 500 RPM
- 6 = 600 RPM
- 7 = 700 RPM
- 8 = 800 RPM
- 9 = 900 RPM
- A = 1000 RPM
- B = 1100 RPM
- C = 1200 RPM
- D = 1300 RPM
- E = 1400 RPM
- F = 1500 RPM
- G = 1600 RPM
- H = 1700 RPM
- J = 1800 RPM
- K = 1900 RPM
- L = 2000 RPM
- M = 2100 RPM
- N = 2200 RPM
- P = 2300 RPM
- R = 2400 RPM

DIGIT 16 - OUTSIDE AIR

- A = No Fresh Air
- B = 0-25% Manual
- D = 0-100% Economizer
- E = 0-100% Economizer w/ Traq/DCV

Note: Must install CO₂ sensor(s) for DCV to function properly

DIGIT 17 - SYSTEM CONTROL

- 1 = CV - Zone Temp Control
- 2 = CV - Discharge Temp Control
- 4 = CV - Zone Temp Control Space Pressure Control w/ Exhaust/Return VFD w/o Bypass
- 5 = CV - Zone Temp Control Space Pressure Control w/ Exhaust/Return VFD and Bypass
- 6 = VAV Discharge Temp Control w/ VFD w/o Bypass
- 7 = VAV Discharge Temp Control w/ VFD and Bypass
- 8 = VAV Discharge Temp Control

- Supply and Exhaust/Return Fan w/ VFD w/o Bypass
- 9 = VAV Discharge Temp Control Supply and Exhaust/Return Fan with VFD and Bypass
- A = VAV - Single Zone VAV - w/ VFD w/o Bypass
- B = VAV - Single Zone VAV - w/ VFD and Bypass
- C = VAV - Single Zone VAV - Supply and Exhaust/Return Fan w/ VFD w/o Bypass
- D = VAV - Single Zone VAV - Supply and Exhaust/Return Fan w/ VFD w/ Bypass

DIGIT 18 - ZONE SENSOR

- 0 = None
- A = Dual Setpoint Manual or Auto Changeover (BAYSENS108*)
- B = Dual Setpoint Manual or Auto Changeover w/ System Function Lights (BAYSENS110*)
- C = Room Sensor w/ Override and Cancel Buttons (BAYSENS073*)
- D = Room Sensor w/ Temperature Adjustment and Override and Cancel Buttons (BAYSENS074*)
- L = Programmable Zone Sensor w/ System Function Lights for CV, SZVAV, and VAV (BAYSENS119*)

Note: *Asterisk indicates current model number digit A, B, C, etc. These sensors can be ordered to ship with the unit.

DIGIT 19 - AMBIENT CONTROL

- 0=Standard
- 1=0° Fahrenheit

DIGIT 20 - AGENCY APPROVAL

- 0=None (cULus Gas Heater, see note)
- 1=cULus

Note: Includes cULus classified gas heating section only when second digit of Model No. is a "F"

DIGITS 21 - 38 - MISC

- 21 A = Unit Disconnect Switch
- 22 B = Hot Gas Bypass
- C = Hot Gas Reheat w/out Hot Gas Bypass
- D = Hot Gas Reheat and Hot Gas Bypass
- 23 0 = Without Economizer
- C = Economizer Control w/ Comparative Enthalpy
- Z = Economizer Control w/ Reference Enthalpy
- W = Economizer Control w/Dry Bulb
- 24 E = Low Leak Economizer Dampers
- U = Ultra Low Leak Economizer Dampers (and Ultra Low Leak Power Exhaust Dampers when Power Exhaust is ordered with this option)
- 25 F = High Duct Temperature Thermostat
- 26 D = Digital Scroll (20-30 Ton, Design Special)

- G = High Capacity Unit
- H = High Efficiency Unit
- V = eFlex Variable Speed Compressor
- 27 0 = Air-Cooled Aluminum Condenser Coil
- J = Corrosion Protected Condenser Coil
- A = Evap Condenser
- B = Evap Condenser w/ Sump Heater
- C = Evap Condenser w/ Dolphin WaterCare System
- D = Evap Condenser w/ Sump Heater and Dolphin WaterCare System
- E = Evap Condenser w/ Conductivity Controller
- F = Evap Condenser w/ Conductivity Controller and Sump Heater
- 28 B = GBAS 0-10V
- K = GBAS 0-5V
- R = Rapid Restart
- 29 A = Motors w/ Internal Shaft Grounding
- 30 M = Remote Human Interface
- 31 N = Ventilation Override Module
- 32 0 = None
- R = Extended Grease Lines
- 1 = Differential Pressure Gauge
- 2 = Extended Grease Lines and Differential Pressure Gauge
- 33 0 = Standard Panels
- T = Access Doors
- U = IRU - w/ Std Panels
- W = IRU - w/ Access Doors
- Y = IRU w/SST - w/ Std Panels
- Z = IRU w/SST - w/ Access Doors
- 34 V = Inter-Processor Communication Bridge
- 35 M = BACnet Communication Interface (BCI) Module
- Y = Trane Communication Interface (TCI) Module
- 7 = Trane LonTalk Communication Interface (LCI) Module
- 36 8 = Spring Isolators
- 37 6 = Factory-Powered 15A GFI Convenience Outlet/Disconnect Switch
- 38 A = Supply Fan Piezometer
- J = Temperature Sensor

Tip: EXAMPLE

Model numbers:
SAHL*5040A68A6BD800100W00G0
B000R000800 describes a unit with the following characteristics:
DX Cooling Only unit w/ no extended casing, 50 ton nominal cooling capacity, 460/60/3 power supply, 100 percent exhaust with Statitrac, 10 HP exhaust fan motor with drive selection No. 8 (800 RPM), throwaway filters, 20 HP supply fan motor with drive selection No. B (1100 RPM), 0-100% economizer w/ dry bulb control, supply and exhaust VFD w/o bypass, no remote panel, standard ambient control, cULus agency approval. High capacity unit, extended grease lines and spring isolators. The service digit for each model number contains 38 digits; all 38 digits must be referenced.

S X H K * 1 1 4 0 A H 8 C E C D 8 0 0 1 * * Z * * * * * * * * * * * * * * * *

1 2 3 4 5 6 7 8 9 10 11 12 13 14 15 16 17 18 19 20 21 22 23 24 25 26 27 28 29 30 31 32 33 34 35 36 37 38

DIGIT 1 - UNIT TYPE

S = Self-Contained (Packaged Rooftop)

DIGIT 2 - UNIT FUNCTION

E = DX Cooling, Electric Heat
 F = DX Cooling, Natural Gas Heat
 L = DX Cooling, Hot Water Heat
 S = DX Cooling, Steam Heat
 X = DX Cooling, No Heat, Extended Casing

DIGIT 3 - UNIT AIRFLOW

H = Single Zone

DIGIT 4 - DEVELOPMENT SEQUENCE

K = R-410A Development Sequence

DIGITS 5,6,7 - NOMINAL CAPACITY

*90 = 90 Tons Air-Cooled
 *11 = 105 Tons Air-Cooled
 *12 = 115 Tons Air-Cooled
 *13 = 130 Tons Air-Cooled

DIGIT 8 - POWER SUPPLY (See Notes)

4 = 460/60/3 XL
 5 = 575/60/3 XL

DIGIT 9 - HEATING CAPACITY

0 = No Heat
 H = High Heat - 2-Stage
 J = High Heat - Limited Modulation
 P = High Heat - Full Modulation

Note: When the second digit calls for "E" (electric heat), the following values apply in the ninth digit:

W = 190 kW

Note: When the second digit calls for "L" (Hot Water) or "S" (Steam) Heat, one of the following valve size values must be in Digit 9:

High Heat Coil: 3 = 1", 4 = 1.25", 5 = 1.5", 6 = 2", 7 = 2.5"
 Low Heat Coil: C = 1", D = 1.25", E = 1.5", F = 2", G = 2.5"

DIGIT 10 - DESIGN SEQUENCE

A = First (Factory Assigned)

Note: Sequence may be any letter A thru Z, or any digit 1 thru 9.

DIGIT 11 - EXHAUST OPTION

0 = None
 7 = 100% Exhaust 15 HP w/Statitrac
 8 = 100% Exhaust 20 HP w/Statitrac
 9 = 100% Exhaust 25 HP w/Statitrac
 F = 50% Exhaust 15 HP
 H = 100% Exhaust 30 HP w/ Statitrac
 J = 100% Exhaust 40 HP w/ Statitrac
 K = 100% Exhaust 15 HP w/o Statitrac (CV Only)
 L = 100% Exhaust 20 HP w/o Statitrac (CV Only)
 M = 100% Exhaust 25 HP w/o Statitrac (CV Only)
 N = 100% Exhaust 30 HP w/o Statitrac (CV Only)
 P = 100% Exhaust 40 HP w/o Statitrac (CV Only)

DIGIT 12 - EXHAUST AIR FAN DRIVE

(Exhaust Fan)
 0 = None
 5 = 500 RPM
 6 = 600 RPM
 7 = 700 RPM
 8 = 800 RPM

DIGIT 13 - FILTER (PRE DX/FINAL)

A = Throwaway
 C = High-Efficiency Throwaway
 D = Bag With Prefilter
 E = Cartridge with Prefilter
 F = Throwaway Filter Rack (Filter Not Included)
 G = Bag Filter Rack (Filter Not Included)
 H = Standard Throwaway Filter/ Cartridge Final Filters
 J = High Efficiency Throwaway Filter/ Cartridge Final Filters
 K = Bag Filters with 2" Throwaway Prefilters/Cartridge Final Filters
 L = Cartridge Filters with 2" Throwaway Prefilters /Cartridge Final Filters
 M = Standard Throwaway Filter /Cartridge Final Filters with 2" Throwaway Prefilters
 N = High Efficiency Throwaway Filters/ Cartridge Final Filters with 2" Throwaway Prefilters
 P = Bag Filters with Prefilters /Cartridge Final Filters with 2" Throwaway Prefilters
 Q = Cartridge Filters with Prefilters/ Cartridge Final Filters with 2" Throwaway Prefilters

DIGIT 14 - SUPPLY AIR FAN HP

C = 30 HP (2-15 HP)
 D = 40 HP (2-20 HP)
 E = 50 HP (2-25 HP)
 F = 60 HP (2-30 HP)
 G = 80 HP (2-40 HP)

DIGIT 15 - SUPPLY AIR FAN DRIVE

A = 1000 RPM
 B = 1100 RPM
 C = 1200 RPM
 D = 1300 RPM
 E = 1400 RPM
 F = 1500 RPM
 G = 1600 RPM

DIGIT 16 - OUTSIDE AIR

D = 0-100% Economizer (Std.)
 E = 0-100% Economizer w/ Traq w/ DCV

Note: Must install CO₂ sensor(s) for DCV to function properly

DIGIT 17 - SYSTEM CONTROL

1 = CV - Zone Temperature Control
 2 = CV - Discharge Temperature Control
 4 = CV - Zone Temperature Control Space Pressure Control w/ Exhaust VFD w/o Bypass
 5 = CV - Zone Temperature Control Space Pressure Control w/ Exhaust VFD and Bypass
 6 = VAV Discharge Temperature Control w/ VFD w/o Bypass
 7 = VAV Discharge Temperature Control w/ VFD and Bypass
 8 = VAV Discharge Temperature Control Supply and Exhaust Fan w/ VFD w/o Bypass
 9 = VAV Discharge Temperature Control Supply and Exhaust Fan w/ VFD and Bypass
 A = VAV - Single Zone VAV - w/ VFD w/o Bypass
 B = VAV - Single Zone VAV - w/ VFD w/ Bypass
 C = VAV - Single Zone VAV - Supply and Exhaust/Return Fan w/ VFD w/o Bypass
 D = VAV - Single Zone VAV - Supply and Exhaust/Return Fan w/ VFD w/ Bypass

Model Number Descriptions

DIGIT 18 - ZONE SENSOR

- 0 = None
- A = Dual Setpoint Manual or Auto Changeover (BAYSENS108*)
- B = Dual Setpoint Manual or Auto Changeover w/ System Function Lights (BAYSENS110*)
- C = Room Sensor w/ Override and Cancel Buttons (BAYSENS073*)
- D = Room Sensor w/ Temperature Adjustment and Override and Cancel Buttons (BAYSENS074*)
- L = Programmable Zone Sensor w/ System Function Lights for both CV and VAV (BAYSENS119*)

Note: *Asterisk indicates current model number digit A, B, C, etc. These sensors can be ordered to ship with the unit.

DIGIT 19 - AMBIENT CONTROL

- 0 = Standard

DIGIT 20 - AGENCY APPROVAL

- 0 = None (cULus Gas Heater, see note)
- 1 = cULus

Note: Includes cULus classified gas heating section only when second digit of Model No. is a "F"

DIGITS 21 - 38 - MISCELLANEOUS

- 21 A = Unit Disconnect Switch
- 22 B = Hot Gas Bypass
- 23 C = Economizer Control w/ Comparative Enthalpy
- Z = Economizer Control w/ Reference Enthalpy
- W = Economizer Control w/Dry Bulb
- 24 E = Low Leak Economizer Dampers
- U = Ultra Low Leak Economizer Dampers (Design Special provided with Ultra Low Leak Exhaust Dampers when power relief also ordered)
- 25 F = High Duct Temperature Thermostat
- 26 G = High Capacity Evap. Coil (105 Ton)
- H = High Cap. Evap. Coil and High Eff. Cond. Coil (90 Ton)
- 27 0 = Air-Cooled Aluminum Condenser Coil
- J = Corrosion-Protected Condenser Coil
- 28 K = Generic B.A.S Module
- R = Rapid Restart
- 29 A = Motors w/ Internal Shaft Grounding
- 30 M = Remote Human Interface
- 31 N = Ventilation Override Module
- 32 0 = None
- R = Extended Grease Lines
- 1 = Differential Pressure Gauge
- 2 = Extended Grease Lines and Differential Pressure Gauge
- 33 0 = Standard Panels
- T = Access Doors
- U = IRU - w/ Std Panels
- W = IRU - w/ Access Doors
- Y = IRU w/SST - w/ Std Panels
- 34 V = Inter-Processor Communication Bridge
- 35 Y = Trane Communication Interface (TCI) Module
- M = BACnet Communication Interface (BCI) Module
- 7 = Trane LonTalk Communication Interface (LCI) Module
- 37 6 = Factory-Powered 15A GFI Convenience Outlet

Tip: EXAMPLE

*Model numbers: SXHK*1140AH8CECD8001**Z describes a unit with the following characteristics: DX cooling with extended casing, no heat, 105 ton nominal cooling capacity, 460/60/3 power supply, 100 percent exhaust with Statitrac, 30 h.p. exhaust fan motor with drive selection No. 8 - (800 RPM), high-efficiency throwaway filters, 50 hp supply fan motor with 1200 RPM, economizer, w/ reference enthalpy control, Supply and Exhaust with VFD but no bypass, cULus agency approval. The service digit for each model number contains 36 digits; all 36 digits must be referenced.*

General Data

Table 6. General Data - 20-50 Tons

	20(a) Ton	25(a) Ton	30(a) Ton	40(a) Ton	50(a) Ton
Compressor Data - Standard Capacity(b)					
Number/Size (Nominal)	2/10 Scroll	1/10, 1/11.5 Scroll	2/13.5 Scroll	2/7.5, 2/9 Scroll	4/10 Scroll
Unit Capacity Steps (%)	100/50 3450	100/46 3450	100/50 3450	100/72/45/23 3450	100/75/50/25 3450
No. of Circuits	1	1	1	2	2
Compressor Data - High Capacity/High Efficiency(b)					
Number/Size (Nominal)	2/10.5 Scroll	1/10, 1/13.5 Scroll	1/13.5, 1/15 Scroll	4/9 Scroll	2/10, 2/11.5 Scroll
Unit Capacity Steps (%)	100/50 3450	100/43 3450	100/47 3450	100/75/50/25 3450	100/73/46/23 3450
No. of Circuits	1	1	1	2	2
Compressor Data - Variable Speed(b)					
Number/Size (Nominal)	N/A	N/A	N/A	1/4-17 VS, 1/9, 1/7.5 Scroll	1/6-25 VS, 1/10, 1/11.5 Scroll
Unit Capacity Steps (%)	N/A	N/A	N/A	15-100 2	15-100 2
No. of Circuits	N/A	N/A	N/A	2	2
Air-Cooled Condenser Fans					
Number/Size/Type	2/26"/Prop 1	3/26"/Prop 1	3/26"/Prop 1	4/26"/Prop 1	6/26"/Prop 1
Cycle/Phase	60/3	60/3	60/3	60/3	60/3
Evaporator Fans					
Number/Size/Type	2/15"/FC 1	2/15"/FC 1	2/18"/FC 1	2/20"/FC 1	2/20"/FC 1
Number of Motors	3-20	3-20	3-20	3-25	7.5-30
Cfm Range ^(c)	4000-9000	5000-11000	6000-13500	8000-18000	10000-22500
ESP Range - (In. WG)	0.25-4.0	0.25-4.0	0.25-4.0	0.25-4.0	0.25-4.0
Exhaust Fans					
Number/Size/Type	1/15"/FC 3	1/15"/FC 3	1/15"/FC 3-5	1/18"/FC 5-7.5	1/18"/FC 5-15
Cfm Range ^(c)	2000-6000	4000-10000	2000-7000	3000-11000	9000-20000
ESP Range - (In. WG)	0.25-1.4	0.2-2.0	0.25-1.4	0.25-1.4	0.25-1.4
Return Fans					
Number/Size/Type	1/24.5/AF 3.0	1/24.5/AF 3.0 - 5.0 HP	1/24.5/AF 3.0 - 7.5	1/27.0/AF 5.0 - 10.0	1/27.0/AF 5.0 - 15.0
Cfm Range ^(c)	4000-9000	4000-11000	4000-12500	7500-18000	9000-20000
ESP Range - (In. WG)	0.25 - 2.0	0.25 - 2.0	0.25 - 2.0	0.25 - 2.0	0.25 - 2.0
Evaporator Coil					
Size (Ft)	20.3	20.3	25.5	32.5	38
Rows/Fin Series	4/168	4/168	5/168	5/168	4/168
Tube Diameter/Surface	1/2"/Enhanced	1/2"/Enhanced	3/8"/Enhanced	3/8"/Enhanced	1/2"/Enhanced
Air-Cooled Condenser Coil					
Face Area (Ft ²)	58	58	58	116	116
Fin Series	252	252	252	252	252
Type	Microchannel	Microchannel	Microchannel	Microchannel	Microchannel
Electric Heat					
kW Range ^(d)	30-110	30-130	30-150	50-170	90-190
Capacity Steps:	3	3	3	3	3



General Data

Table 6. General Data - 20-50 Tons (continued)

	20(a) Ton	25(a) Ton	30(a) Ton	40(a) Ton	50(a) Ton
Natural Gas Heat					
Standard Gas Heat ^(e)					
Low Heat Input	235	235	350	350	500
High Heat Input	500	500	500	850	850
Std. Heating Capacity Steps:	2	2	2	2	2
Modulating Gas Heat (Not Available on 20-40 Ton Models with Low Heat)					
High Heat - Limited Modulation ^(f)	See Table 10	See Table 10	See Table 10	See Table 10	See Table 10
Heat Exchanger Type	Standard	Standard	Standard	Standard	Standard
High Heat - Full Modulation ^(g)	See Table 10	See Table 10	See Table 10	See Table 10	See Table 10
Heat Exchanger Type	Stainless Steel	Stainless Steel	Stainless Steel	Stainless Steel	Stainless Steel
Hot Water Coil					
Size (Inches)	30x66x2 Row 5W Prima-Flo E w/ turbulators	30x66x2 Row 5W Prima-Flo E w/ turbulators	30x66x2 Row 5W Prima-Flo E w/ turbulators	42x66x2 Row 5W Prima-Flo E w/ turbulators	42x66x2 Row 5W Prima-Flo E w/ turbulators
Type	110	110	110	110	110
High Heat (Fins/Ft)	80	80	80	80	80
Low Heat (Fins/Ft)					
Steam Coil					
Size (Inches)	30x66x1 Row	30x66x1 Row	30x66x1 Row	30x66x1 Row	30x66x1 Row
Type	Type NS	Type NS	Type NS	Type NS	Type NS
High Heat (Fins/Ft)	96	96	96	96	72
Low Heat (Fins/Ft)	42	42	42	42	42
Pre-Evap Filters					
Panel Filters					
Number/Size (Inches)	12 - 20x20x2	12 - 20x20x2	16 - 20x20x2	16 - 20x25x2	20 - 20x25x2
Face Area (Ft ²)	33.3	33.3	44.4	55.5	69.4
Bag Filters					
Number/Size (Inches)	4 - 12x24x19 3 - 24x24x19	4 - 12x24x19 3 - 24x24x19	2 - 12x24x19 6 - 24x24x19	5 - 12x24x19 6 - 24x24x19	3 - 12x24x19 9 - 24x24x19
Cartridge Filters	4 - 12x24x12 3 - 24x24x12	4 - 12x24x12 3 - 24x24x12	2 - 12x24x12 6 - 24x24x12	5 - 12x24x12 6 - 24x24x12	3 - 12x24x12 9 - 24x24x12
Prefilters (For Bag & Cartridge)	4 - 12x24x2 3 - 24x24x2	4 - 12x24x2 3 - 24x24x2	2 - 12x24x2 6 - 24x24x2	5 - 12x24x2 6 - 24x24x2	3 - 12x24x2 9 - 24x24x2
Face Area (Ft ²)	20	20	28	34	42
Final Filters (SX Units only)					
Cartridge Filters	4 - 12x24x12	4 - 12x24x12	1 - 12x24x12	5 - 12x24x12	2 - 12x24x12
Number/Size (Inches)	3 - 24x24x12	3 - 24x24x12	6 - 24x24x12	6 - 24x24x12	9 - 24x24x12
Prefilters	4 - 12x24x2	4 - 12x24x2	1 - 12x24x2	5 - 12x24x2	2 - 12x24x2
(For Cartridge Filters)	3 - 24x24x2	3 - 24x24x2	6 - 24x24x2	6 - 24x24x2	9 - 24x24x2
Face Area (Ft ²)	20	20	26	34	40
Standard Unit Minimum Outside Air Temperature for Mechanical Cooling					
Without Hot Gas Option	55°F	50°F	50°F	55°F	45°F
With Hot Gas Option	55°F	50°F	50°F	55°F	45°F
Low Ambient Option Minimum Outside Air Temperature					
Without Hot Gas Option	0°F	0°F	0°F	0°F	0°F
With Hot Gas Option	10°F	10°F	10°F	10°F	10°F

(a) Model sizes are listed are for air-cooled/evaporative condensers. Not all data applies to both condenser configurations.
 (b) 20/24-30/36 ton models are single circuit, 40/48 ton models are dual circuit.
 (c) For CFM values outside these ranges, contact your local Trane sales office.
 (d) Refer to Table 52, p. 84 for availability of electric heat kW ranges by voltage
 (e) Two-stage gas heat: 1st stage 50% on gas heat exchangers up to 500 Mbbh; 60% on 800-1000 Mbbh gas heat exchangers.
 (f) The firing rate of the unit can vary from 33% of the heater Mbbh up to the nameplate rating of the unit.
 (g) The firing rate of the unit can vary from pilot rate of 125,000 Btuh up to the nameplate rating of the unit.

Table 7. General Data - 55 - 75 Tons

	55^(a) Ton		60^(a) Ton		70^(a) Ton		75^(a) Ton	
Compressor Data - Standard Capacity^(b)								
Number/Size (Nominal)	4/11.5		2/11.5, 2/13.5		4/15		2/14.5, 2/20	
Model	Scroll		Scroll		Scroll		Scroll	
Unit Capacity Steps (%)	100/75/50/25		100/73/46/23		100/75/50/25		100/71/43/21	
RPM	3450		3450		3450		3450	
No. of Circuits	2		2		2		2	
Compressor Data - High Capacity/High Efficiency^(b)								
Number/Size (Nominal)	N/A		4/13.5		N/A		2/15.5, 2/21	
Model	N/A		Scroll		N/A		Scroll	
Unit Capacity Steps (%)	N/A		100/73/46/23		N/A		100/71/43/21	
RPM	N/A		N/A		N/A		N/A	
No. of Circuits	N/A		2		N/A		2	
Compressor Data - Variable Speed^(b)								
Number/Size (Nominal)	1/6-25 VS, 1/11.5, 1/13.5		1/6-25 VS, 1/13.5, 1/15		1/6-25 VS, 1/15, 1/20		N/A	
Model	Scroll		Scroll		Scroll		N/A	
Unit Capacity Steps (%)	15-100		15-100		15-100		N/A	
No. of Circuits	2		2		2		N/A	
Condenser Fans								
Number/Size/Type	N/A		6/26"/Prop		6/26"/Prop		6/26"/Prop	
Hp (each)	N/A		1		1		1	
Cycle/Phase	N/A		60/3		60/3		60/3	
Evaporator Fans								
Number/Size/Type	2/20"/FC	1/30.0"/DDP	2/22"/FC	2/24.5"/DDP	2/22"/FC	2/27.0"/DDP	2/22"/FC	2/27.0"/DDP
Number of Motors	1	1	1	2	1	2	1	2
Hp Range	7.5-30	5-30	10-50 ^(c)	10-40	10-50 ^(c)	10-50	10-50 ^(c)	10-50
Cfm Range ^(d)	10000-22500		14000-27000		16000-27000		16000-27000	
ESP Range - (In. WG)	0.25-4.0		0.25-4.0		0.25-4.0		0.25-4.0	
Exhaust Fans								
	50%	100%	50%	100%	50%	100%	50%	100%
Number/Size/Type	1/18"/FC	2/18"/FC	1/20"/FC	2/20"/FC	1/20"/FC	2/20"/FC	1/20"/FC	2/20"/FC
Hp Range	5-7.5	5-15	5-7.5	5-20	5-7.5	5-20	5-7.5	5-20
Cfm Range ^(d)	3000-11000	9000-20000	4000-13000	12000-27000	4000-13000	12000-27000	4000-13000	12000-27000
ESP Range - (In. WG)	0.25-1.4	0.20-2.0	0.25-1.4	0.20-2.0	0.25-1.4	0.20-2.0	0.25-1.4	0.20-2.0
Return Fans								
Number/Size/Type	1/27.0"/AF		1/36.5"/AF		1/36.5"/AF		1/36.5"/AF	
Hp Range	5.0 - 15.0		5.0 - 20.0		5.0 - 20.0		5.0 - 20.0	
Cfm Range ^(d)	9000-20000		12000-27000		12000-27000		12000-27000	
ESP Range - (In. WG)	0.25 - 2.0		0.25 - 2.0		0.25 - 2.0		0.25 - 2.0	
Evaporator Coil								
Size (Ft)	38		43		43		43	
Rows/Fin Series	4/168		6/168		6/168		6/168	
Tube Diameter/Surface	1/2"/Enhanced		3/8"/Enhanced		3/8"/Enhanced		3/8"/Enhanced	
Air-Cooled Condenser Coil								
Face Area (Ft ²)	116		136		136		136	
Fin Series	252		252		252		252	
Type	Microchannel		Microchannel		Microchannel		Microchannel	
Electric Heat								
kW Range ^(e)	70-190		90-190		90-190		90-190	
Capacity Steps:	3		3		3		3	
Natural Gas Heat								
Standard Gas Heat ^(f)	500		500		500		500	
Low Heat Input	850		850		850		850	
High Heat Input	850		850		850		850	
Standard Heating Capacity Steps:	2		2		2		2	
Modulating Gas Heat								
High/Low Heat - Limited Modulation ^(g)	See Table 10		See Table 10		See Table 10		See Table 10	
Heat Exchanger Type	Standard		Standard		Standard		Standard	
High/Low Heat - Full Modulation ^(h)	See Table 10		See Table 10		See Table 10		See Table 10	
Heat Exchanger Type	Stainless Steel		Stainless Steel		Stainless Steel		Stainless Steel	
Hot Water Coil								
Size (Inches)	42x66x2 Row		42x90x2 Row		42x90x2 Row		42x90x2 Row	

General Data

Table 7. General Data - 55 - 75 Tons (continued)

	55^(a) Ton	60^(a) Ton	70^(a) Ton	75^(a) Ton
Type	5W Prima-Flo E w/ turbolators	5W Prima-Flo E w/ turbolators	5W Prima-Flo E w/ turbolators	5W Prima-Flo E w/ turbolators
High Heat (Fins/Ft)	110	110	110	110
Low Heat (Fins/Ft)	80	80	80	80
Steam Coil				
Size (Inches)	30x66x1 Row 12x66x1 Row	30x90x1 Row 12x90x1 Row	30x90x1 Row 12x90x1 Row	30x90x1 Row 12x90x1 Row
Type	Type NS	Type NS	Type NS	Type NS
High Heat (Fins/Ft)	96	72	72	72
Low Heat (Fins/Ft)	42	42	42	42
Pre-Evap Filters				
Panel Filters				
Number/Size (Inches)	20 - 20x25x2	35 - 16x20x2	35 - 16x20x2	35 - 16x20x2
Face Area (Ft ²)	69.4	77.8	77.8	77.8
Bag Filters				
Number/Size (Inches)	3 - 12x24x19 9 - 24x24x19	6 - 12x24x19 8 - 24x24x19	6 - 12x24x19 8 - 24x24x19	6 - 12x24x19 8 - 24x24x19
Cartridge Filters				
Number/Size (Inches)	3 - 12x24x12 9 - 24x24x12	6 - 12x24x12 8 - 24x24x12	6 - 12x24x12 8 - 24x24x12	6 - 12x24x12 8 - 24x24x12
Prefilters (For Bag & Cartridge)	3 - 12x24x2 9 - 24x24x2	6 - 12x24x2 8 - 24x24x2	6 - 12x24x2 8 - 24x24x2	6 - 12x24x2 8 - 24x24x2
Face Area (Ft ²)	42	44	44	44
Final Filters (SX Units only)				
Cartridge Filters	2 - 12x24x12	6 - 12x24x12	6 - 12x24x12	6 - 12x24x12
Number/Size (Inches)	9 - 24x24x12	8 - 24x24x12	8 - 24x24x12	8 - 24x24x12
Prefilters (For Cartridge Filters)	2 - 12x24x2 9 - 24x24x2	6 - 12x24x2 8 - 24x24x2	6 - 12x24x2 8 - 24x24x2	6 - 12x24x2 8 - 24x24x2
Face Area (Ft ²)	40	44	44	44
Standard Unit Min. Outside Air Temperature For Mechanical Cooling				
Without Hot Gas Option	35°F	30°F	45°F	45°F
With Hot Gas Option	35°F	30°F	45°F	45°F
Low Ambient Option Min. Outside Air Temp				
Without Hot Gas Option	0°F	0°F	0°F	0°F
With Hot Gas Option	10°F	10°F	10°F	10°F

- (a) Model sizes are listed are for air-cooled/evaporative condensers. Not all data applies to both condenser configurations.
 (b) 50-89 ton models are dual circuit
 (c) 40 & 50 Hp available as standard in 460 & 575 volt only
 (d) For CFM values outside these ranges, contact your local Trane sales office.
 (e) Refer to [Table 52, p. 84](#) for availability of electric heat kW ranges by voltage.
 (f) Two-stage gas heat: 1st stage 50% on gas heat exchangers up to 500 Mbh; 60% on 800-1000 Mbh gas heat exchangers
 (g) The firing rate of the unit can vary from 33% of the heater Mbh up to the nameplate rating of the unit.
 (h) The firing rate of the unit can vary from pilot rate of 125,000 Btuh up to the nameplate rating of the unit.

Table 8. General Data - 90-130 Tons

	90 Ton		105 Ton		115 Ton		130 Ton	
Compressor Data - Standard Capacity^(a)								
Number/Size (Nominal)	4/20		2/20 2/25		2/20 2/25		4/25	
Model	Scroll		Scroll		Scroll		Scroll	
Unit Capacity Steps (%)	100/75/50/25		100/72/44/22		100/72/44/22		100/75/50/25	
RPM	3450		3450		3450		3450	
No. of Circuits	2		2		2		2	
Evaporator Fans								
Number/Size/Type	2/28"/AF		2/28"/AF		2/28"/AF		2/28"/AF	
Number of Motors	2		2		2		2	
Hp Range	30-80		30-80		30-80		30-80	
Cfm Range ^(b)	31,000-46,000		31,000-46,000 ^(c)		31,000-46,000		31,000-46,000	
ESP Range - (In. WG)	1.0-4.70		1.0-4.70		1.0-4.70		1.0-4.70	
Exhaust Fans								
	50%	100%	50%	100%	50%	100%	50%	100%
Number/Size/Type	1/22"/FC	2/22"/FC	1/22"/FC	2/22"/FC	1/22"/FC	2/22"/FC	1/22"/FC	2/22"/FC
Hp Range	15	15-40	15	15-40	15	15-40	15	15-40
Cfm Range ^(b)	12,000-20,000	28,000-40,000	12,000-20,000	28,000-40,000	12,000-20,000	28,000-40,000	12,000-20,000	28,000-40,000
ESP Range - (In. WG)	.25-2.5	.25-2.5	.25-2.5	.25-2.5	.25-2.5	.25-2.5	.25-2.5	.25-2.5
Condenser Fans								
Number/Size/Type	8/26"/Prop.		10/26"/Prop.		10/26"/Prop.		12/26"/Prop.	
Hp (Each)	1		1		1		1	
Cfm	56,400		56,400		56,400		56,400	
Cycle/Phase	60/3		60/3		60/3		60/3	
Evaporator Coil - Standard Capacity								
Dimensions	122.0 x 70.0		NA		122.0 x 70.0		122.0 x 70.0	
Size (Ft)	59.3		NA		59.3		59.3	
Rows/Fin Series	4/148		NA		6/148		6/148	
Tube Diameter/Surface	1/2 Enhanced		NA		1/2 Enhanced		1/2 Enhanced	
Evaporator Coil - High Capacity								
Dimensions	122.0 x 70.0		122.0 x 70.0		NA		NA	
Size (Ft)	59.3		59.3		NA		NA	
Rows/Fin Series	6/148		6/148		NA		NA	
Tube Diameter/Surface	1/2 Enhanced		1/2 Enhanced		NA		NA	
Condenser Coil - Standard Efficiency (Al Fins)								
Size (Ft ²)	N/A		152		152		152	
Rows/Fin Series	N/A		2/276		2/276		2/276	
Type	N/A		Microchannel		Microchannel		Microchannel	
Condenser Coil - Hi Efficiency (Al Fins)								
Size (Ft ²)	152		NA		NA		NA	
Rows/Fin Series	2/276		NA		NA		NA	
Tube Diameter	Microchannel		NA		NA		NA	
Electric Heat								
kW Range ^(d)	190		190		190		190	
Capacity Steps	3		3		3		3	
Natural Gas Heat								
Standard Gas Heat ^(e)	1000		1000		1000		1000	
Standard Heating Capacity Steps:	2		2		2		2	
High Heat - Limited Modulation ^(f)	See Table 10		See Table 10		See Table 10		See Table 10	
Heat Exchanger Type	Standard		Standard		Standard		Standard	

General Data

Table 8. General Data - 90-130 Tons (continued)

	90 Ton	105 Ton	115 Ton	130 Ton
High Heat - Full Modulation ⁽⁹⁾	See Table 10	See Table 10	See Table 10	See Table 10
Heat Exchanger Type	Stainless Steel	Stainless Steel	Stainless Steel	Stainless Steel
Hot Water Coil				
Size (Inches)	(2) 30x84x2 Row	(2) 30x84x2 Row	(2) 30x84x2 Row	(2) 30x84x2 Row
Type	5W Prima-Flo E w/turbolators	5W Prima-Flo E w/turbolators	5W Prima-Flo E w/turbolators	5W Prima-Flo E w/turbolators
High Heat (Fins/Ft)	110	110	110	110
Low Heat (Fins/Ft)	80	80	80	80
Steam Coil				
Size (Inches)	(2) 30x84x1 Row	(2) 30x84x1 Row	(2) 30x84x1 Row	(2) 30x84x1 Row
Type	Type NS	Type NS	Type NS	Type NS
High Heat (Fins/Ft)	96	96	96	96
Low Heat (Fins/Ft)	52	52	52	52
Filters				
Panel Filters				
Number/Size (Inches)	25-24x24x2	25-24x24x2	25-24x24x2	25-24x24x2
Face Area (Ft ²)	100	100	100	100
Bag Filters				
Number/Size (Inches)	3-12x24x19	3-12x24x19	3-12x24x19	3-12x24x19
Number/Size (Inches)	15-24x24x19	15-24x24x19	15-24x24x19	15-24x24x19
Cartridge Filters				
Number/Size (Inches)	3-12x24x12	3-12x24x12	3-12x24x12	3-12x24x12
Number/Size (Inches)	15-24x24x12	15-24x24x12	15-24x24x12	15-24x24x12
Prefilters				
Number/Size (Inches)	3-20x24x2	3-20x24x2	3-20x24x2	3-20x24x2
(For Bag & Cartridge)	15-24x24x2	15-24x24x2	15-24x24x2	15-24x24x2
Face Area (Ft ²)	66	66	66	66
Final Filters (SX Units only)				
Cartridge Filters	5 - 12x24x12	5 - 12x24x12	5 - 12x24x12	5 - 12x24x12
Number/Size (Inches)	10 - 24x24x12	10 - 24x24x12	10 - 24x24x12	10 - 24x24x12
Prefilters	5 - 12x24x2	5 - 12x24x2	5 - 12x24x2	5 - 12x24x2
(For Cartridge Filters)	10 - 24x24x2	10 - 24x24x2	10 - 24x24x2	10 - 24x24x2
Face Area (Ft ²)	50	50	50	50
Standard Unit Minimum Outside Air Temperature for Mechanical Cooling				
Without Hot Gas Option	45°F	45°F	45°F	45°F
With Hot Gas Option	45°F	45°F	45°F	45°F

(a) 90-130 ton models are dual circuit

(b) For CFM values outside these ranges, contact your local Trane sales office.

(c) Max CFM for 105 ton std is 44,000

(d) Refer to [Table 52, p. 84](#) for availability of electric heat kW ranges by voltage.

(e) Two-stage gas heat: 1st stage 50% on gas heat exchangers up to 500 Mbh; 60% on 800-1000 Mbh gas heat exchangers

(f) The firing rate of the unit can vary from 33% of the heater Mbh up to the nameplate rating of the unit.

(g) The firing rate of the unit can vary from pilot rate of 125,000 Btuh up to the nameplate rating of the unit.

Table 9. Economizer Outdoor Air Damper Leakage (of Rated Airflow)

	ΔP Across Dampers (In. WC)	
	0.5 (In.)	1.0 (In.)
Standard	1.5 %	2.5 %
Optional Low Leak	0.5 %	1.0 %
Optional Ultra Low Leak		3 CFM/Ft ²

Note: Above data for Standard and Low Leak based on tests completed in accordance with AMCA Standard 500 at AMCA Laboratories. Ultra Low Leak Damper leakage rate is AMCA certified.

Table 10. Gas Heat Inputs/Input Ranges

Standard Gas Heat (MBh)	Two-Stage Gas Heat		Modulating Gas Heat^(a)	
	Low Fire	High Fire	Full Modulating Heat	Limited Modulating Heat
	Heat Input (MBh)	Heat Input (MBh)	Input Range (MBh)	Input Range (MBh)
235	120	235	NA	NA
350	175	350	NA	NA
500	250	500	125 - 500	167 - 500
850	425	850	125 - 850	284 - 850
1000	500	1000	125 - 1000	334 - 1000

(a) Modulating Gas Heat (Not available on 24-48 ton evaporative condensing models with low heat)

Performance Adjustment Factors

Table 11. Enthalpy of Saturated AIR

Wet Bulb Temperature	Btu Per Lb.
40	15.23
41	15.70
42	16.17
43	16.66
44	17.15
45	17.65
46	18.16
47	18.68
48	19.21
49	19.75
50	20.30
51	20.86
52	21.44
53	22.02
54	22.62
55	23.22
56	23.84
57	24.48
58	25.12
59	25.78
60	26.46
61	27.15
62	27.85
63	28.57
64	29.31
65	30.06
66	30.83
67	31.62
68	32.42
69	33.25
70	34.09
71	34.95
72	35.83
73	36.74
74	37.66
75	38.61

Figure 8. Air Density Ratios

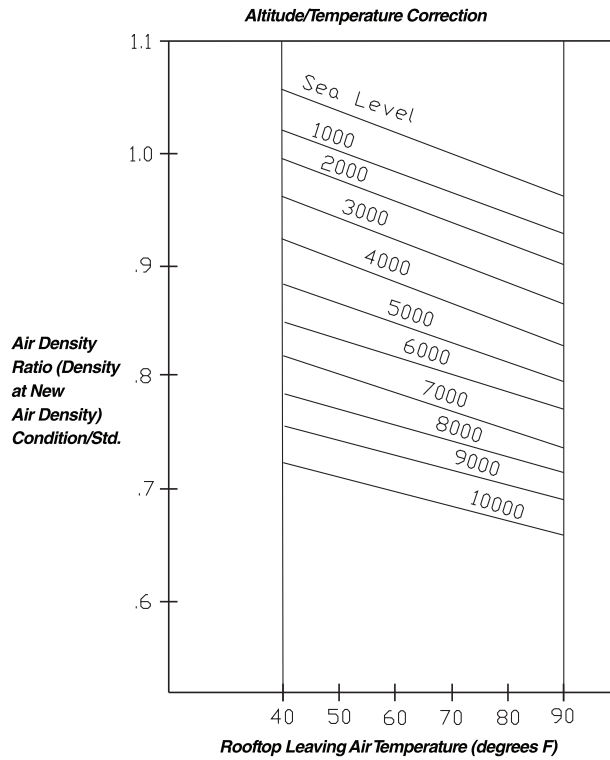

Table 12. Cooling Capacity Altitude Correction Factors

	Altitude (Ft)							
	Sea Level	1000	2000	3000	4000	5000	6000	7000
Cooling Capacity Multiplier	1.00	0.99	0.99	0.98	0.97	0.96	0.95	0.94
kW Correction Multiplier (Compressors)	1.00	1.01	1.02	1.03	1.04	1.05	1.06	1.07
SHR Correction Multiplier	1.00	.98	.95	.93	.91	.89	.87	.85
Maximum Condenser Ambient	118°F	119°F	120°F	121°F	122°F	123°F	124°F	125°F

Note: SHR = Sensible Heat Ratio

Table 13. Gas Heating Capacity Altitude Correction Factors

Capacity Multiplier	Altitude (Ft)						
	Sea Level To 2000	2001 To 2500	2501 To 3500	3501 To 4500	4501 To 5500	5501 To 6500	6501 To 7500
	1.00	.92	.88	.84	.80	.76	.72

Note: Correction factors are per AGA Std 221.30 - 1964, Part VI, 6.12. Local codes may supersede.



Performance Data

Air-Cooled Performance Data

Table 14. Gross Cooling Capacities (MBh) —20 Ton Air-Cooled — Standard Capacity — R-410A

CFM	ENT DB (F)	Ambient Temperature																	
		85						95						105					
		Entering Wet Bulb																	
		61		67		73		61		67		73		61		67		73	
		CAP	SHC	CAP	SHC	CAP	SHC	CAP	SHC	CAP	SHC	CAP	SHC	CAP	SHC	CAP	SHC	CAP	SHC
4000	75	205	145	230	119	255	91	196	140	220	114	244	86	186	134	209	108	230	80
	80	207	167	231	141	256	113	198	162	220	136	244	108	189	156	209	130	231	102
	85	209	189	232	163	256	135	201	184	222	158	244	129	191	178	211	152	231	123
	90	213	212	233	184	256	156	205	205	223	179	245	151	196	196	212	173	232	145
6000	75	230	179	253	139	273	96	219	173	241	134	260	90	207	166	228	127	244	84
	80	233	211	254	171	274	128	223	205	242	165	260	122	211	199	229	159	245	116
	85	240	240	255	202	274	160	230	230	243	196	261	154	219	219	230	189	245	148
	90	252	252	256	233	275	190	242	242	244	227	261	184	230	230	230	220	245	177
7000	75	237	194	260	148	278	97	225	188	247	142	264	92	213	181	233	136	247	86
	80	242	232	261	184	278	134	231	226	248	178	264	129	218	218	234	171	247	122
	85	252	252	261	220	278	171	242	242	249	213	264	165	230	230	234	206	247	158
	90	264	264	262	255	279	206	253	253	249	249	264	199	239	239	235	235	247	192
8000	75	242	208	264	157	281	99	230	202	251	151	266	94	217	195	236	144	250	88
	80	249	249	265	196	281	141	239	239	252	190	266	135	226	226	237	183	249	129
	85	262	262	266	237	282	182	250	250	252	230	266	175	237	237	237	223	249	168
	90	272	272	266	266	283	221	259	259	253	253	267	215	244	244	238	238	250	207
9000	75	247	222	268	165	283	101	234	215	254	159	268	95	221	208	239	153	252	89
	80	257	257	268	208	285	148	246	246	255	202	268	142	233	233	239	195	251	136
	85	268	268	269	253	285	193	256	256	255	247	269	186	242	242	240	240	251	179
	90	278	278	269	269	286	237	264	264	255	255	270	230	249	249	240	240	252	223
CFM	ENT DB (F)	Ambient Temperature 115																	
		Entering Wet Bulb																	
		61		67		73		61		67		73		61		67		73	
		CAP	SHC	CAP	SHC	CAP	SHC	CAP	SHC	CAP	SHC	CAP	SHC	CAP	SHC	CAP	SHC	CAP	SHC
4000	75	176	129	197	102	216	74												
	80	179	150	197	124	217	95												
	85	181	172	199	146	217	117												
	90	188	188	200	166	218	139												
6000	75	194	160	213	121	228	78												
	80	199	192	214	152	228	109												
	85	208	208	215	182	228	141												
	90	217	217	216	213	228	170												
7000	75	200	174	217	129	230	79												
	80	206	206	218	164	230	116												
	85	217	217	219	199	229	150												
	90	225	225	219	219	229	184												
8000	75	203	188	220	138	232	81												
	80	213	213	221	176	231	122												
	85	222	222	221	216	231	160												
	90	228	228	222	222	231	200												
9000	75	206	201	223	143	234	83												
	80	218	218	223	187	232	129												
	85	226	226	223	223	232	171												
	90	232	232	223	223	232	215												

Note: Cooling capacity will be slightly different for 200V units. Please see TOPSS™ for corrected performance

Performance Data

Air-Cooled - Gross Cooling Capacities

Table 15. Gross Cooling Capacities (MBh) – 20 Ton Air-Cooled – High Efficiency – R-410A

CFM	ENT DB (F)	Ambient Temperature																	
		85						95						105					
		Entering Wet Bulb																	
		61		67		73		61		67		73		61		67		73	
		CAP	SHC	CAP	SHC	CAP	SHC	CAP	SHC	CAP	SHC	CAP	SHC	CAP	SHC	CAP	SHC	CAP	SHC
4000	75	227	160	255	132	284	102	217	154	244	126	272	97	207	148	232	120	258	90
	80	230	184	256	155	285	126	220	178	244	149	273	120	209	171	232	143	259	114
	85	232	207	257	179	285	149	222	201	246	173	273	143	211	195	234	167	259	137
	90	235	231	258	202	285	172	225	225	247	196	273	166	216	216	235	189	259	160
6000	75	255	196	282	154	310	109	243	190	270	148	295	103	231	183	255	141	278	96
	80	259	231	284	189	311	144	248	225	271	182	296	137	235	218	256	175	279	130
	85	265	265	285	222	311	178	255	255	272	216	296	172	243	243	257	208	279	165
	90	279	279	286	255	312	212	268	268	273	248	297	205	256	256	258	241	280	197
7000	75	264	213	291	164	317	112	251	206	277	158	301	105	238	199	262	151	283	98
	80	269	254	292	203	318	152	257	247	278	197	302	145	244	240	263	189	283	138
	85	280	280	294	242	318	192	269	269	280	235	302	185	256	256	264	227	284	177
	90	295	295	295	280	319	229	283	283	281	273	303	222	269	269	265	265	285	214
8000	75	270	228	298	174	322	114	257	221	283	167	305	108	243	214	267	160	286	101
	80	278	275	299	217	322	159	265	265	284	210	306	153	252	252	268	203	287	145
	85	292	292	300	260	323	203	280	280	285	253	306	196	266	266	269	246	287	188
	90	307	307	301	301	323	245	293	293	286	286	307	238	278	278	270	270	287	230
9000	75	276	243	302	183	325	116	262	236	287	176	308	110	247	228	270	169	289	103
	80	286	286	303	230	326	167	274	274	288	223	309	160	260	260	271	215	289	153
	85	302	302	304	279	326	215	289	289	289	272	309	207	274	274	272	264	289	199
	90	316	316	305	305	326	262	301	301	290	290	309	254	285	285	273	273	289	246
CFM	ENT DB (F)	Ambient Temperature																	
		115																	
		Entering Wet Bulb																	
		61		67		73		61		67		73		61		67		73	
		CAP	SHC	CAP	SHC	CAP	SHC	CAP	SHC	CAP	SHC	CAP	SHC	CAP	SHC	CAP	SHC	CAP	SHC
4000	75	195	142	219	113	243	84												
	80	198	165	220	137	243	107												
	85	201	188	222	160	244	130												
	90	207	207	222	183	244	153												
6000	75	217	176	239	134	259	89												
	80	221	210	240	168	260	123												
	85	231	231	242	200	260	157												
	90	243	243	242	233	261	189												
7000	75	223	191	245	143	263	91												
	80	230	230	246	181	264	130												
	85	242	242	247	219	264	169												
	90	254	254	248	248	264	205												
8000	75	228	206	249	153	266	93												
	80	238	238	250	194	266	138												
	85	251	251	251	237	267	180												
	90	261	261	252	252	266	221												
9000	75	232	220	252	162	269	95												
	80	245	245	253	207	268	145												
	85	257	257	254	254	268	190												
	90	266	266	254	254	267	237												

Note: Cooling capacity will be slightly different for 200V units. Please see TOPSS™ for corrected performance



Performance Data

Air-Cooled - Gross Cooling Capacities

Table 16. Gross Cooling Capacities (MBh) – 25 Ton Air-Cooled – Standard Capacity – R-410A

CFM	ENT DB (F)	Ambient Temperature																	
		85						95						105					
		Entering Wet Bulb																	
		61		67		73		61		67		73		61		67		73	
		CAP	SHC	CAP	SHC	CAP	SHC	CAP	SHC	CAP	SHC	CAP	SHC	CAP	SHC	CAP	SHC	CAP	SHC
5000	75	250	182	279	147	310	111	240	176	266	141	296	105	228	169	252	134	281	99
	80	253	211	279	176	311	140	243	204	267	170	297	134	231	197	253	163	282	127
	85	257	240	282	205	311	168	246	233	270	198	297	162	234	226	257	191	281	155
	90	264	264	284	232	311	197	255	255	272	226	297	191	245	245	258	219	282	184
7000	75	273	216	302	169	329	117	260	209	288	162	314	111	246	201	272	155	296	104
	80	278	256	303	207	330	157	266	249	290	200	315	150	252	241	274	193	298	143
	85	287	287	305	245	330	196	276	276	291	238	316	189	264	264	276	230	298	182
	90	303	303	306	282	332	233	291	291	293	275	317	226	278	278	277	268	299	218
8750	75	285	242	313	185	338	121	271	235	298	179	322	115	256	227	282	172	303	108
	80	293	293	315	230	339	170	281	281	300	223	323	163	267	267	283	215	304	156
	85	309	309	316	277	340	216	297	297	302	269	323	208	282	282	285	261	305	200
	90	324	324	317	317	340	260	311	311	303	303	323	253	295	295	286	286	304	245
10000	75	291	260	319	197	343	124	277	252	303	190	326	118	261	244	286	179	307	111
	80	304	304	320	246	343	179	291	291	305	239	326	172	277	277	288	231	307	165
	85	320	320	322	299	343	229	307	307	306	291	326	221	291	291	289	283	307	213
	90	334	334	322	322	344	280	319	319	307	307	326	272	302	302	290	290	306	264
11000	75	295	273	322	205	346	126	281	266	307	195	329	120	265	258	289	186	309	113
	80	311	311	324	258	345	186	298	298	308	251	328	180	283	283	291	243	309	173
	85	327	327	325	316	346	240	313	313	309	308	328	232	297	297	292	292	308	223
	90	340	340	325	325	347	296	324	324	310	310	328	288	306	306	292	292	308	279
CFM	ENT DB (F)	Ambient Temperature																	
		115																	
		Entering Wet Bulb																	
		61		67		73		61		67		73		61		67		73	
		CAP	SHC	CAP	SHC	CAP	SHC	CAP	SHC	CAP	SHC	CAP	SHC	CAP	SHC	CAP	SHC	CAP	SHC
5000	75	215	162	238	127	264	91												
	80	218	190	238	156	265	120												
	85	222	219	242	184	265	148												
	90	233	233	244	211	267	177												
7000	75	232	193	256	148	277	97												
	80	238	233	257	185	278	136												
	85	251	251	259	222	279	173												
	90	264	264	260	259	280	209												
8750	75	241	218	264	164	283	101												
	80	253	253	266	207	284	149												
	85	267	267	267	253	284	192												
	90	278	278	268	268	283	236												
10000	75	245	235	268	171	287	103												
	80	261	261	269	222	287	158												
	85	274	274	270	270	286	204												
	90	283	283	271	271	285	254												
11000	75	248	248	270	178	289	106												
	80	267	267	272	234	289	167												
	85	279	279	272	272	286	214												
	90	286	286	273	273	286	270												

Note: Cooling capacity will be slightly different for 200V units. Please see TOPSS™ for corrected performance

Performance Data

Air-Cooled - Gross Cooling Capacities

Table 17. Gross Cooling Capacities (MBh)—25 Ton Air-Cooled — High Efficiency — R-410A

CFM	ENT DB (F)	Ambient Temperature																	
		85						95						105					
		Entering Wet Bulb																	
		61		67		73		61		67		73		61		67		73	
		CAP	SHC	CAP	SHC	CAP	SHC	CAP	SHC	CAP	SHC	CAP	SHC	CAP	SHC	CAP	SHC	CAP	SHC
5000	75	266	191	296	156	331	120	255	184	284	149	317	114	242	177	271	143	301	106
	80	269	220	297	185	332	149	257	213	284	178	318	143	245	206	270	171	302	135
	85	272	249	300	214	332	178	261	242	287	208	320	172	249	235	273	200	302	164
	90	277	277	301	242	332	206	268	268	289	235	318	200	257	257	275	228	302	193
7000	75	291	225	323	178	356	127	278	218	309	171	339	120	264	210	292	164	321	113
	80	296	266	325	218	357	167	283	259	310	211	341	160	269	251	294	203	323	153
	85	304	304	327	256	356	207	292	292	312	248	340	200	280	280	296	240	321	192
	90	320	320	328	294	360	245	309	309	314	287	344	238	295	295	298	278	325	230
8750	75	305	253	337	196	368	132	291	245	321	189	350	125	275	237	303	181	330	117
	80	313	304	339	242	370	181	300	296	323	234	352	174	284	284	306	226	332	167
	85	329	329	341	289	371	229	316	316	325	281	353	222	301	301	308	273	333	213
	90	347	347	342	336	372	275	333	333	327	327	355	267	318	318	309	309	335	258
10000	75	312	271	344	207	374	135	298	263	327	200	355	128	281	254	309	192	334	120
	80	323	323	346	258	376	191	310	310	330	251	357	184	296	296	312	242	337	176
	85	342	342	348	312	377	243	329	329	332	304	359	235	313	313	313	295	338	227
	90	360	360	349	349	378	295	345	345	333	333	360	287	329	329	315	315	339	278
11000	75	317	285	348	217	377	137	302	277	331	210	359	130	285	268	313	202	337	122
	80	332	332	351	271	379	199	319	319	334	263	361	192	303	303	315	254	340	184
	85	351	351	352	329	381	254	337	337	336	321	362	246	320	320	317	312	341	237
	90	369	369	354	354	381	311	353	353	337	337	363	303	335	335	318	318	341	294
CFM	ENT DB (F)	Ambient Temperature																	
		115																	
		Entering Wet Bulb																	
		61		67		73		61		67		73		61		67		73	
		CAP	SHC	CAP	SHC	CAP	SHC	CAP	SHC	CAP	SHC	CAP	SHC	CAP	SHC	CAP	SHC	CAP	SHC
5000	75	229	170	256	135	283	99												
	80	232	198	255	164	285	128												
	85	236	227	259	192	284	156												
	90	246	246	260	220	285	185												
7000	75	248	202	275	156	300	105												
	80	254	242	277	194	302	145												
	85	266	266	279	232	303	184												
	90	281	281	280	269	305	221												
8750	75	259	228	284	173	308	109												
	80	269	269	287	217	310	158												
	85	285	285	289	263	311	204												
	90	300	300	290	290	312	249												
10000	75	264	245	289	184	312	112												
	80	279	279	292	232	314	168												
	85	295	295	293	285	315	217												
	90	309	309	294	294	316	268												
11000	75	267	259	292	188	314	114												
	80	286	286	295	245	317	175												
	85	302	302	296	296	317	227												
	90	315	315	297	297	318	284												

Note: Cooling capacity will be slightly different for 200V units. Please see TOPSS™ for corrected performance



Performance Data

Air-Cooled - Gross Cooling Capacities

Table 18. Gross Cooling Capacities (MBh)— 30 Ton Air-Cooled — Standard Capacity — R-410A

CFM	ENT DB (F)	Ambient Temperature																	
		85						95						105					
		61		67		73		61		67		73		61		67		73	
		CAP	SHC	CAP	SHC	CAP	SHC	CAP	SHC	CAP	SHC	CAP	SHC	CAP	SHC	CAP	SHC	CAP	SHC
6000	75	303	221	339	180	373	135	290	214	324	173	356	129	273	206	306	165	336	121
	80	307	256	339	214	374	170	293	248	323	206	357	163	278	240	305	198	338	155
	85	310	290	342	248	374	204	296	282	326	240	358	196	281	274	309	232	339	188
	90	317	317	343	280	374	237	306	306	328	272	357	230	293	293	311	264	338	222
9000	75	334	268	367	209	396	143	318	260	350	201	376	136	300	250	330	193	355	128
	80	339	321	368	256	396	192	324	313	351	248	377	185	306	304	331	239	356	177
	85	351	351	370	303	397	240	337	337	353	294	378	233	321	321	333	285	357	225
	90	368	368	371	349	398	286	353	353	354	341	379	278	336	336	334	332	357	269
10500	75	344	289	375	221	402	146	327	280	357	214	382	139	308	270	336	205	360	131
	80	348	348	376	274	403	202	334	334	358	266	383	195	317	317	338	256	361	187
	85	367	367	378	328	404	258	352	352	360	319	383	251	334	334	339	310	361	242
	90	383	383	379	379	405	308	367	367	361	361	384	300	349	349	340	340	361	290
12000	75	351	308	381	233	407	149	333	299	362	226	387	142	314	290	341	217	364	134
	80	361	361	382	291	408	212	346	346	364	283	386	205	328	328	343	273	364	197
	85	379	379	383	352	409	275	363	363	365	343	387	267	344	344	344	333	364	253
	90	393	393	384	384	410	330	376	376	365	365	388	321	357	357	344	344	364	311
13500	75	356	327	385	245	411	152	338	318	366	237	390	145	318	308	345	229	367	137
	80	371	371	386	308	412	222	355	355	368	299	390	214	336	336	346	289	366	206
	85	388	388	387	375	413	292	371	371	368	366	391	280	351	351	347	347	366	267
	90	404	404	387	387	415	352	384	384	369	369	391	343	363	363	347	347	366	332
CFM	ENT DB (F)	Ambient Temperature 115																	
		Entering Wet Bulb																	
		61		67		73		61		67		73		61		67		73	
		CAP	SHC	CAP	SHC	CAP	SHC	CAP	SHC	CAP	SHC	CAP	SHC	CAP	SHC	CAP	SHC	CAP	SHC
6000	75	260	198	289	157	316	113												
	80	263	232	288	190	317	147												
	85	267	266	291	223	319	180												
	90	280	280	293	255	318	213												
9000	75	282	241	309	184	332	120												
	80	288	288	311	229	333	168												
	85	304	304	312	275	334	217												
	90	318	318	314	314	334	259												
10500	75	289	261	315	196	337	123												
	80	300	300	316	246	337	178												
	85	316	316	318	300	337	229												
	90	329	329	319	319	337	280												
12000	75	294	280	319	208	340	126												
	80	310	310	321	263	340	188												
	85	324	324	321	321	340	243												
	90	335	335	322	322	339	301												
13500	75	298	298	322	213	343	129												
	80	317	317	324	279	344	200												
	85	330	330	324	324	341	256												
	90	340	340	325	325	341	322												

Note: Cooling capacity will be slightly different for 200V units. Please see TOPSS™ for corrected performance

Table 19. Gross Cooling Capacities (MBh)— 30 Ton Air-Cooled — High Efficiency — R-410A

CFM	ENT DB (F)	Ambient Temperature																	
		85						95						105					
		Entering Wet Bulb																	
		61		67		73		61		67		73		61		67		73	
CAP	SHC	CAP	SHC	CAP	SHC	CAP	SHC	CAP	SHC	CAP	SHC	CAP	SHC	CAP	SHC	CAP	SHC		
6000	75	320	231	358	190	398	146	306	224	343	182	380	138	292	216	325	174	360	130
	80	324	267	359	224	399	181	310	259	343	216	381	173	294	250	324	208	361	164
	85	327	302	362	259	401	215	313	294	346	251	383	207	298	285	328	242	361	199
	90	332	332	363	292	400	249	321	321	347	284	381	241	308	308	330	275	361	232
9000	75	355	280	392	220	430	155	338	271	373	212	408	147	320	262	352	203	384	138
	80	360	334	394	270	432	206	344	326	375	261	410	198	325	316	354	251	387	189
	85	370	370	396	317	434	256	356	356	377	308	413	248	339	339	356	298	389	239
	90	390	390	398	365	435	303	375	375	379	356	414	294	357	357	358	346	391	285
10500	75	366	302	402	234	439	159	348	293	383	225	416	151	328	282	360	216	391	142
	80	373	366	404	289	441	217	353	353	384	279	419	209	336	336	363	269	395	200
	85	389	389	407	343	443	275	373	373	387	334	421	266	355	355	365	324	397	257
	90	410	410	408	398	445	327	393	393	389	389	423	318	374	374	367	367	399	308
12000	75	374	322	410	246	445	162	355	313	389	238	422	154	335	302	367	229	396	145
	80	383	383	412	307	448	228	367	367	392	297	426	219	349	349	369	287	401	211
	85	405	405	415	369	450	293	388	388	394	359	428	284	369	369	371	349	403	276
	90	426	426	416	416	452	350	408	408	396	396	429	341	388	388	373	373	405	331
13500	75	380	342	416	259	451	166	361	332	395	250	427	157	340	321	371	241	400	148
	80	395	395	419	324	454	238	378	378	398	315	431	230	359	359	374	304	406	221
	85	417	417	421	393	456	309	399	399	400	383	433	301	379	379	376	373	408	292
	90	439	439	423	423	458	372	420	420	401	401	435	363	399	399	378	378	410	353
CFM	ENT DB (F)	Ambient Temperature 115																	
		Entering Wet Bulb																	
		61		67		73		61		67		73		61		67		73	
		CAP	SHC	CAP	SHC	CAP	SHC	CAP	SHC	CAP	SHC	CAP	SHC	CAP	SHC	CAP	SHC	CAP	SHC
6000	75	275	207	306	165	337	121												
	80	277	241	305	199	339	156												
	85	282	276	309	233	339	190												
	90	294	294	311	265	339	223												
9000	75	300	251	330	194	359	129												
	80	306	305	332	240	363	180												
	85	321	321	334	287	365	230												
	90	339	339	336	335	367	274												
10500	75	307	272	337	206	365	133												
	80	318	318	339	258	370	191												
	85	336	336	341	313	372	248												
	90	354	354	343	343	374	298												
12000	75	313	291	342	219	370	136												
	80	329	329	345	276	375	201												
	85	348	348	347	338	377	265												
	90	367	367	349	349	379	320												
13500	75	318	310	346	231	373	140												
	80	338	338	350	293	379	212												
	85	358	358	352	352	381	275												
	90	376	376	353	353	383	342												

Note: Cooling capacity will be slightly different for 200V units. Please see TOPSS™ for corrected performance



Performance Data

Air-Cooled - Gross Cooling Capacities

Table 20. Gross Cooling Capacities (MBh)— 40 Ton Air-Cooled — Standard Capacity — R-410A

CFM	ENT DB (F)	Ambient Temperature																	
		85						95						105					
		61		67		73		61		67		73		61		67		73	
CAP	SHC	CAP	SHC	CAP	SHC	CAP	SHC	CAP	SHC	CAP	SHC	CAP	SHC	CAP	SHC	CAP	SHC	CAP	SHC
8000	75	387	283	434	230	484	175	371	273	415	221	462	166	352	263	394	211	438	156
	80	390	331	434	274	484	220	373	321	414	265	463	211	355	311	392	254	439	200
	85	389	374	436	317	485	263	374	363	417	307	465	254	357	350	397	297	439	244
	90	403	403	439	366	488	307	390	390	420	356	466	298	374	374	399	345	442	287
11000	75	419	327	466	259	514	185	400	317	444	249	489	175	379	306	420	239	462	165
	80	423	396	467	316	516	244	400	384	446	306	492	234	384	375	422	294	465	223
	85	434	434	470	371	518	301	417	417	449	361	494	292	399	399	425	349	468	281
	90	458	458	475	443	519	357	441	441	448	429	495	346	422	422	427	414	469	334
14000	75	439	367	486	284	532	192	418	356	462	274	505	183	395	344	436	263	476	172
	80	444	444	488	352	535	265	426	426	465	341	509	255	406	406	439	328	480	244
	85	470	470	491	420	537	335	452	452	468	408	512	325	431	431	442	396	483	314
	90	496	496	496	496	539	401	477	477	476	476	513	389	455	455	455	455	485	377
16000	75	449	391	495	300	540	197	427	380	471	289	513	187	403	367	444	278	482	176
	80	461	461	498	374	544	277	443	443	474	362	517	267	421	421	447	350	487	256
	85	489	489	501	450	546	357	469	469	477	439	520	347	447	447	450	426	489	335
	90	515	515	515	515	548	428	494	494	494	494	521	417	471	471	471	471	491	404
18000	75	457	414	503	314	546	201	434	403	478	304	518	191	410	390	450	292	487	180
	80	476	476	506	395	549	290	456	456	481	383	521	279	434	434	454	370	490	268
	85	504	504	509	479	553	377	483	483	484	467	526	367	460	460	457	450	495	351
	90	531	531	531	531	555	454	509	509	509	509	528	443	484	484	483	483	496	430
CFM	ENT DB (F)	Ambient Temperature																	
		115																	
		61		67		73		61		67		73		61		67		73	
CAP	SHC	CAP	SHC	CAP	SHC	CAP	SHC	CAP	SHC	CAP	SHC	CAP	SHC	CAP	SHC	CAP	SHC	CAP	SHC
8000	75	332	252	371	200	412	145												
	80	335	300	370	244	413	190												
	85	338	338	374	285	415	233												
	90	357	357	377	334	416	276												
11000	75	356	293	395	227	432	153												
	80	360	355	397	282	436	212												
	85	379	379	400	336	438	269												
	90	401	401	401	401	440	321												
14000	75	371	331	409	251	444	160												
	80	385	385	412	315	448	232												
	85	408	408	415	383	451	302												
	90	430	430	430	430	452	363												
16000	75	378	354	416	266	449	164												
	80	398	398	419	336	454	244												
	85	422	422	422	412	456	323												
	90	444	444	444	444	458	390												
18000	75	384	376	421	280	453	168												
	80	410	410	425	356	456	256												
	85	434	434	427	427	460	337												
	90	455	455	454	454	462	415												

Note: Cooling capacity will be slightly different for 200V units. Please see TOPSS™ for corrected performance

Performance Data

Air-Cooled - Gross Cooling Capacities

Table 21. Gross Cooling Capacities (MBh)— 40 Ton Air-Cooled — High Capacity — R-410A

CFM	ENT DB (F)	Ambient Temperature																	
		85						95						105					
		61		67		73		61		67		73		61		67		73	
Entering Wet Bulb		61		67		73		61		67		73		61		67		73	
CAP	SHC	CAP	SHC	CAP	SHC	CAP	SHC	CAP	SHC	CAP	SHC	CAP	SHC	CAP	SHC	CAP	SHC	CAP	SHC
8000	75	409	295	459	242	510	185	392	286	440	233	487	176	374	275	418	222	462	165
	80	413	344	458	286	510	231	396	334	439	276	488	221	377	323	417	266	463	210
	85	416	389	461	330	511	274	399	379	442	320	489	264	377	365	420	309	464	253
	90	422	422	463	379	513	318	408	408	444	369	491	308	392	392	423	357	466	297
11000	75	445	341	493	271	542	195	425	331	471	261	516	185	403	319	446	249	487	173
	80	449	410	494	330	543	254	429	400	472	319	518	244	407	387	447	306	489	232
	85	455	455	497	385	545	312	439	439	475	373	519	301	420	420	450	361	491	290
	90	480	480	501	456	545	369	462	462	479	445	520	357	442	442	449	430	492	344
14000	75	467	381	514	296	560	202	445	370	490	285	532	192	421	357	463	274	500	180
	80	471	463	516	365	562	275	449	449	492	353	534	264	428	428	465	341	503	252
	85	493	493	519	433	564	345	474	474	495	421	536	334	452	452	468	408	504	322
	90	519	519	519	519	565	412	499	499	498	498	537	400	475	475	475	475	505	386
16000	75	478	406	524	311	568	206	455	394	499	301	539	196	430	381	471	289	507	184
	80	486	486	526	387	570	287	466	466	501	375	542	276	444	444	473	362	509	264
	85	513	513	529	463	572	366	492	492	504	451	543	355	468	468	476	438	510	343
	90	538	538	538	538	573	439	516	516	516	516	544	426	491	491	490	490	511	412
18000	75	486	429	532	326	575	211	463	417	506	315	545	200	437	404	477	303	511	188
	80	501	501	534	408	577	299	480	480	508	395	546	288	457	457	479	382	513	276
	85	528	528	537	492	578	387	506	506	511	480	548	375	481	481	482	466	514	363
	90	554	554	554	554	579	464	530	530	530	530	549	452	502	502	502	502	514	437
CFM	ENT DB (F)	Ambient Temperature																	
		115																	
		61		67		73													
Entering Wet Bulb		61		67		73													
CAP	SHC	CAP	SHC	CAP	SHC	CAP	SHC												
8000	75	353	264	394	211	434	154												
	80	356	311	393	254	435	198												
	85	358	351	397	297	437	241												
	90	375	375	399	345	438	285												
11000	75	379	306	419	238	454	161												
	80	384	375	420	293	456	219												
	85	399	399	423	348	458	277												
	90	420	420	424	412	459	330												
14000	75	395	343	433	261	465	167												
	80	406	406	435	326	467	238												
	85	428	428	438	394	468	308												
	90	448	448	448	448	469	370												
16000	75	403	367	440	276	470	171												
	80	420	420	442	347	472	250												
	85	442	442	444	423	473	329												
	90	461	461	460	460	473	396												
18000	75	409	389	445	290	474	175												
	80	431	431	447	367	475	262												
	85	452	452	449	444	476	343												
	90	469	469	469	469	476	421												

Note: Cooling capacity will be slightly different for 200V units. Please see TOPSS™ for corrected performance

Performance Data

Air-Cooled - Gross Cooling Capacities

Table 22. Gross Cooling Capacities (MBh) — 40 Ton Air-Cooled — High Efficiency — R-410A

CFM	ENT DB (F)	Ambient Temperature																	
		85						95						105					
		61		67		73		61		67		73		61		67		73	
Entering Wet Bulb		61		67		73		61		67		73		61		67		73	
CAP	SHC	CAP	SHC	CAP	SHC	CAP	SHC	CAP	SHC	CAP	SHC	CAP	SHC	CAP	SHC	CAP	SHC	CAP	SHC
8000	75	415	300	466	246	517	188	398	290	446	236	494	178	380	279	424	225	469	168
	80	419	349	465	291	518	234	402	339	445	281	495	224	382	328	423	270	470	213
	85	422	395	468	335	518	278	405	385	448	325	497	268	382	370	426	313	470	257
	90	428	428	470	385	521	323	414	414	451	374	498	313	398	398	429	363	473	301
11000	75	451	347	501	275	550	198	431	336	478	265	524	187	409	323	452	253	494	176
	80	455	416	501	335	551	258	436	406	479	323	525	247	413	393	454	311	496	236
	85	462	462	504	390	553	317	445	445	482	379	527	306	426	426	457	366	498	294
	90	487	487	508	462	553	374	469	469	486	451	528	362	449	449	455	436	499	349
14000	75	474	387	522	301	568	205	452	375	497	290	540	194	427	362	470	278	508	183
	80	478	469	524	370	570	279	455	455	499	359	542	268	434	434	472	346	510	255
	85	501	501	527	439	572	350	481	481	502	427	544	339	459	459	475	414	512	327
	90	527	527	526	526	573	418	506	506	506	506	545	405	482	482	482	482	513	391
16000	75	485	412	532	316	576	209	462	400	506	305	547	199	436	386	478	293	514	187
	80	493	493	534	393	579	291	473	473	509	380	550	280	450	450	480	367	516	268
	85	520	520	537	470	580	372	499	499	511	458	551	360	475	475	483	444	517	348
	90	546	546	546	546	582	445	524	524	524	524	552	432	498	498	498	498	518	418
18000	75	493	436	540	331	583	214	470	423	513	320	553	203	443	410	484	308	519	191
	80	508	508	542	414	585	304	487	487	516	401	554	292	464	464	487	387	520	280
	85	536	536	545	499	587	392	514	514	518	487	556	381	488	488	489	473	522	368
	90	562	562	562	562	588	471	538	538	538	538	557	458	509	509	509	509	522	443
CFM	ENT DB (F)	Ambient Temperature																	
		115																	
		Entering Wet Bulb																	
CFM	ENT DB (F)	61		67		73		61		67		73		61		67		73	
		CAP	SHC	CAP	SHC	CAP	SHC	CAP	SHC	CAP	SHC	CAP	SHC	CAP	SHC	CAP	SHC	CAP	SHC
8000	75	359	267	400	214	440	156												
	80	362	316	399	258	442	201												
	85	364	356	403	301	443	245												
	90	380	380	405	350	445	289												
11000	75	385	310	425	241	461	163												
	80	390	380	426	298	463	223												
	85	405	405	429	353	465	281												
	90	426	426	430	419	466	335												
14000	75	401	349	440	265	472	170												
	80	412	412	442	331	474	242												
	85	434	434	444	400	475	313												
	90	455	455	455	455	476	376												
16000	75	409	372	446	280	477	174												
	80	426	426	449	352	479	254												
	85	448	448	451	429	480	334												
	90	467	467	467	467	480	402												
18000	75	415	395	452	294	481	178												
	80	437	437	454	372	482	266												
	85	459	459	456	451	483	348												
	90	476	476	476	476	483	427												

Note: Cooling capacity will be slightly different for 200V units. Please see TOPSS™ for corrected performance

Table 23. Gross Cooling Capacities (MBh)— 40 Ton Air-Cooled — eFlex™ Variable Speed Compressor — R-410A

CFM	ENT DB (F)	Ambient Temperature																	
		85						95						105					
		Entering Wet Bulb																	
		61		67		73		61		67		73		61		67		73	
		CAP	SHC	CAP	SHC	CAP	SHC	CAP	SHC	CAP	SHC	CAP	SHC	CAP	SHC	CAP	SHC	CAP	SHC
8000	75	390	286	436	232	486	176	374	276	418	223	465	167	356	266	398	213	442	157
	80	393	334	436	276	486	221	377	325	417	267	466	212	359	314	397	257	443	202
	85	397	380	439	320	487	265	381	370	421	310	467	256	362	355	401	300	443	246
	90	407	407	441	369	490	309	393	393	423	360	469	300	378	378	404	349	446	290
11000	75	421	330	468	261	516	185	403	320	447	251	492	176	383	309	424	241	466	166
	80	426	400	469	319	518	245	403	387	448	308	494	236	385	374	426	297	469	225
	85	437	437	472	374	520	303	421	421	452	364	497	294	404	404	429	353	471	284
	90	461	461	477	446	521	359	444	444	457	436	498	349	426	426	432	423	473	338
14000	75	441	370	487	286	533	193	421	359	465	276	508	184	399	348	440	266	480	173
	80	446	446	490	354	536	266	429	429	467	343	511	256	410	410	443	332	484	246
	85	473	473	493	423	539	338	455	455	470	412	514	328	435	435	446	400	487	317
	90	498	498	498	498	540	403	479	479	479	479	516	393	459	459	458	458	489	381
16000	75	451	394	497	301	542	198	430	383	473	291	515	188	407	371	448	281	487	178
	80	464	464	499	376	545	279	446	446	476	365	520	269	425	425	451	353	491	259
	85	491	491	502	453	548	359	472	472	479	442	522	349	451	451	454	431	494	339
	90	517	517	517	517	549	431	497	497	497	497	524	420	475	475	474	474	496	408
18000	75	458	418	504	316	548	202	437	407	480	306	521	192	414	394	454	295	492	182
	80	479	479	507	397	550	291	459	459	483	386	524	281	438	438	458	374	494	271
	85	506	506	510	483	555	380	486	486	486	472	528	370	463	463	460	454	499	354
	90	533	533	533	533	556	458	511	511	511	511	530	447	487	487	487	487	501	434
CFM	ENT DB (F)	Ambient Temperature																	
		115																	
		Entering Wet Bulb																	
		61		67		73		61		67		73		61		67		73	
		CAP	SHC	CAP	SHC	CAP	SHC	CAP	SHC	CAP	SHC	CAP	SHC	CAP	SHC	CAP	SHC	CAP	SHC
8000	75	338	256	377	203	417	147												
	80	341	304	375	247	419	192												
	85	343	343	380	289	421	236												
	90	362	362	383	338	421	279												
11000	75	361	298	400	231	439	156												
	80	365	360	402	286	442	215												
	85	385	385	405	341	444	273												
	90	406	406	406	406	445	326												
14000	75	376	335	415	255	451	163												
	80	390	390	418	320	455	235												
	85	413	413	420	388	457	306												
	90	436	436	435	435	459	368												
16000	75	383	359	421	270	456	167												
	80	404	404	425	341	461	248												
	85	428	428	427	417	463	327												
	90	449	449	449	449	464	395												
18000	75	389	381	427	284	460	171												
	80	415	415	430	361	463	260												
	85	439	439	433	433	468	342												
	90	460	460	460	460	469	421												

Note: Cooling capacity will be slightly different for 200V or 575V units. Please see TOPSS™ for corrected performance



Performance Data

Air-Cooled - Gross Cooling Capacities

Table 24. Gross Cooling Capacities (MBh)— 50 Ton Air-Cooled — Standard Capacity — R-410A

CFM	ENT DB (F)	Ambient Temperature																	
		85						95						105					
		61		67		73		61		67		73		61		67		73	
		CAP	SHC	CAP	SHC	CAP	SHC	CAP	SHC	CAP	SHC	CAP	SHC	CAP	SHC	CAP	SHC	CAP	SHC
10000	75	487	360	542	290	602	218	465	348	517	279	576	207	441	335	492	266	546	194
	80	492	419	541	347	604	276	470	407	517	336	578	265	445	393	490	323	548	252
	85	498	478	546	405	603	332	475	465	522	392	577	321	453	449	496	379	548	309
	90	517	517	551	463	607	390	498	498	528	451	582	378	478	478	502	438	552	365
14000	75	527	426	583	332	641	231	502	412	554	319	612	219	475	398	524	306	578	206
	80	537	509	585	409	644	310	513	496	559	396	615	298	486	479	529	382	581	285
	85	559	559	588	484	644	388	538	538	562	471	614	376	514	514	532	457	582	363
	90	590	590	600	568	648	463	568	568	575	556	619	451	543	543	545	536	585	436
17500	75	548	478	605	364	676	247	522	464	576	352	629	228	493	450	544	339	593	215
	80	568	568	608	456	664	337	545	545	580	443	632	325	520	520	548	428	596	312
	85	602	602	611	549	666	433	578	578	582	536	634	417	551	551	550	521	598	403
	90	634	634	634	634	668	522	609	609	609	609	636	509	580	580	580	580	600	494
20000	75	559	514	616	387	670	245	532	500	586	372	637	233	502	485	553	358	600	220
	80	590	590	619	488	673	356	566	566	590	475	641	344	538	538	557	460	604	330
	85	624	624	622	594	675	462	599	599	593	581	643	445	570	570	559	559	606	430
	90	657	657	657	657	677	562	630	630	630	630	644	549	598	598	598	598	607	534
22500	75	568	548	624	405	677	251	540	535	594	393	644	239	509	509	560	374	605	226
	80	608	608	628	520	680	374	583	583	598	506	647	362	554	554	564	491	606	348
	85	643	643	630	630	682	486	616	616	600	600	649	473	585	585	566	566	611	457
	90	674	674	674	674	683	602	645	645	645	645	650	589	611	611	611	611	612	573
CFM	ENT DB (F)	Ambient Temperature 115																	
		Entering Wet Bulb																	
		61		67		73													
		CAP	SHC	CAP	SHC	CAP	SHC												
10000	75	416	321	464	253	513	181												
	80	420	379	463	310	516	239												
	85	431	431	468	365	516	295												
	90	456	456	474	424	519	351												
14000	75	446	384	494	293	540	192												
	80	460	460	497	367	544	271												
	85	488	488	500	442	545	347												
	90	515	515	515	515	548	421												
17500	75	462	434	509	324	553	201												
	80	491	491	513	412	557	297												
	85	521	521	515	505	559	387												
	90	548	548	547	547	560	477												
20000	75	470	468	517	343	559	206												
	80	508	508	521	444	563	316												
	85	538	538	523	523	565	414												
	90	563	563	562	562	566	517												
22500	75	477	477	524	358	564	212												
	80	522	522	527	474	564	334												
	85	550	550	529	529	569	440												
	90	573	573	572	572	569	556												

Note: Cooling capacity will be slightly different for 200V units. Please see TOPSS™ for corrected performance

Table 25. Gross Cooling Capacities (MBh)— 50 Ton Air-Cooled — High Capacity — R-410A

CFM	ENT DB (F)	Ambient Temperature																	
		85						95						105					
		Entering Wet Bulb																	
		61		67		73		61		67		73		61		67		73	
CAP	SHC	CAP	SHC	CAP	SHC	CAP	SHC	CAP	SHC	CAP	SHC	CAP	SHC	CAP	SHC	CAP	SHC		
10000	75	519	378	580	308	645	235	496	365	555	295	617	223	473	352	528	282	585	209
	80	525	437	580	365	646	293	502	424	554	353	618	281	476	410	526	339	586	267
	85	531	496	584	423	646	350	508	483	559	411	619	338	484	469	531	396	587	324
	90	545	545	589	482	650	408	526	526	564	469	622	395	504	504	535	454	590	381
14000	75	566	446	626	350	689	248	540	432	597	337	656	235	511	417	564	323	619	221
	80	576	529	630	429	691	328	547	512	601	415	658	315	518	499	568	400	622	300
	85	593	593	633	505	691	406	571	571	604	491	659	393	545	545	571	475	622	379
	90	625	625	643	588	694	483	602	602	615	574	662	468	575	575	583	559	625	453
17500	75	591	499	652	384	710	257	563	485	621	370	675	244	532	469	586	355	636	229
	80	606	599	655	477	712	354	581	581	624	462	678	341	553	553	589	446	638	326
	85	640	640	658	570	714	451	614	614	626	556	679	437	585	585	592	539	640	422
	90	673	673	674	668	716	541	646	646	646	646	678	531	615	615	615	615	641	510
20000	75	604	535	664	406	720	262	575	521	632	392	684	249	543	504	596	377	644	235
	80	629	629	667	509	723	373	603	603	635	494	687	359	574	574	599	478	646	345
	85	665	665	670	615	724	480	637	637	638	600	688	466	606	606	601	584	648	447
	90	698	698	698	698	726	581	668	668	668	668	689	567	635	635	634	634	648	550
22500	75	614	571	674	427	728	268	584	556	640	411	691	254	551	539	603	396	650	240
	80	649	649	677	541	730	391	622	622	644	526	694	377	590	590	607	509	652	362
	85	685	685	679	659	732	509	655	655	646	642	695	490	622	622	609	609	653	473
	90	717	717	716	716	733	621	685	685	685	685	695	606	648	648	648	648	653	589
CFM	ENT DB (F)	Ambient Temperature 115																	
		Entering Wet Bulb																	
		61		67		73		61		67		73		61		67		73	
		CAP	SHC	CAP	SHC	CAP	SHC	CAP	SHC	CAP	SHC	CAP	SHC	CAP	SHC	CAP	SHC	CAP	SHC
10000	75	446	338	497	268	549	195												
	80	451	395	496	325	551	252												
	85	455	449	501	381	552	309												
	90	482	482	507	439	554	366												
14000	75	481	401	531	308	579	206												
	80	492	484	534	383	581	285												
	85	518	518	536	459	581	363												
	90	546	546	547	538	585	435												
17500	75	499	452	548	340	592	214												
	80	523	523	551	429	595	310												
	85	553	553	554	522	596	404												
	90	580	580	580	580	597	492												
20000	75	508	487	557	359	599	219												
	80	542	542	560	460	601	328												
	85	571	571	562	562	602	428												
	90	596	596	595	595	603	531												
22500	75	515	515	563	379	604	224												
	80	556	556	566	491	605	347												
	85	584	584	568	568	606	455												
	90	606	606	606	606	606	570												

Note: Cooling capacity will be slightly different for 200V units. Please see TOPSS™ for corrected performance

Performance Data*Air-Cooled - Gross Cooling Capacities***Table 26. Gross Cooling Capacities (MBh) — 50 Ton Air-Cooled — High Efficiency — R-410A**

CFM	ENT DB (F)	Ambient Temperature																			
		85						95						105							
		Entering Wet Bulb																			
		61		67		73		61		67		73		61		67		73			
CAP	SHC	CAP	SHC	CAP	SHC	CAP	SHC	CAP	SHC	CAP	SHC	CAP	SHC	CAP	SHC	CAP	SHC	CAP	SHC		
10000	75	519	378	580	308	645	235	496	365	555	295	617	223	471	351	528	282	585	209		
	80	525	437	580	365	647	293	502	424	554	353	618	281	478	410	526	339	586	267		
	85	531	496	584	423	646	350	508	483	559	411	619	338	484	469	531	397	586	324		
	90	545	545	589	482	650	408	526	526	564	469	622	395	504	504	536	454	590	381		
14000	75	566	446	626	350	689	248	540	432	597	337	656	235	511	417	564	323	620	221		
	80	576	529	630	429	691	328	550	516	601	415	659	315	518	499	569	400	622	300		
	85	593	593	633	505	692	406	571	571	604	491	659	393	546	546	572	475	622	379		
	90	625	625	643	588	695	483	602	602	615	574	663	469	575	575	583	559	626	453		
17500	75	591	499	652	384	711	257	563	485	621	370	676	244	532	469	586	355	636	229		
	80	606	599	655	477	713	355	581	581	624	462	678	341	553	553	589	446	639	327		
	85	640	640	658	570	715	451	614	614	627	556	680	438	585	585	592	540	641	419		
	90	673	673	674	668	717	541	646	646	646	646	682	527	615	615	615	615	642	510		
20000	75	604	535	664	406	721	263	575	521	632	392	685	249	543	504	596	377	644	235		
	80	629	629	668	509	723	373	604	604	635	495	688	360	574	574	599	478	647	345		
	85	665	665	670	615	725	481	638	638	638	600	689	466	606	606	602	584	648	447		
	90	698	698	698	698	727	582	669	669	669	669	690	567	635	635	635	635	649	550		
22500	75	614	571	674	428	729	268	585	555	641	412	692	255	551	539	604	396	650	240		
	80	649	649	677	541	731	391	622	622	644	526	695	378	591	591	607	509	653	363		
	85	685	685	680	659	733	510	656	656	647	643	696	491	623	623	609	609	654	474		
	90	717	717	717	717	734	621	686	686	686	686	697	606	649	649	649	649	654	589		
10000	75	Ambient Temperature 115																			
		Entering Wet Bulb																			
		61		67		73		61		67		73		61		67		73			
		CAP	SHC	CAP	SHC	CAP	SHC	CAP	SHC	CAP	SHC	CAP	SHC	CAP	SHC	CAP	SHC	CAP	SHC	CAP	SHC
10000	446	338	498	268	550	195															
	450	395	496	325	551	253															
	459	455	501	381	552	309															
	482	482	507	439	555	366															
14000	481	401	531	308	579	206															
	492	484	534	384	582	285															
	518	518	537	459	582	363															
	546	546	547	538	585	436															
17500	499	452	548	340	593	214															
	524	524	552	429	596	311															
	553	553	554	522	597	402															
	581	581	580	580	598	492															
20000	508	487	557	359	600	219															
	542	542	560	460	602	329															
	571	571	562	562	603	429															
	597	597	596	596	604	532															
22500	516	516	564	379	605	225															
	557	557	567	491	606	347															
	585	585	569	569	608	455															
	607	607	607	607	607	570															

Note: Cooling capacity will be slightly different for 200V units. Please see TOPSS™ for corrected performance

Performance Data

Air-Cooled - Gross Cooling Capacities

Table 27. Gross Cooling Capacities (MBh)— 50 Ton Air-Cooled — eFlex™ Variable Speed Compressor — R-410A

CFM	ENT DB (F)	Ambient Temperature																	
		85						95						105					
		Entering Wet Bulb																	
		61		67		73		61		67		73		61		67		73	
CAP	SHC	CAP	SHC	CAP	SHC	CAP	SHC	CAP	SHC	CAP	SHC	CAP	SHC	CAP	SHC	CAP	SHC		
10000	75	518	377	577	306	641	233	497	366	555	295	616	222	475	354	531	284	588	211
	80	524	437	576	364	642	291	502	424	554	353	617	280	481	412	530	341	590	269
	85	529	495	581	422	643	349	509	483	559	410	618	338	484	472	535	398	590	326
	90	543	543	585	480	646	406	526	526	564	469	621	395	507	507	540	456	594	383
14000	75	563	444	624	349	686	247	540	432	598	337	657	235	515	419	570	325	625	223
	80	572	528	625	427	688	327	550	515	600	415	659	315	522	501	572	402	628	303
	85	590	590	628	503	688	405	570	570	603	490	659	393	548	548	575	477	627	381
	90	622	622	639	587	692	481	601	601	614	574	663	469	578	578	587	561	632	456
17500	75	587	497	648	382	708	256	563	484	620	370	677	244	536	471	590	357	643	232
	80	602	598	651	475	711	354	580	580	623	462	680	342	557	557	593	448	647	330
	85	636	636	653	568	713	451	614	614	626	555	682	439	589	589	596	541	649	425
	90	670	670	671	667	715	541	646	646	646	646	685	528	620	620	620	620	651	514
20000	75	600	533	660	404	719	262	574	520	631	392	687	250	547	506	600	378	652	238
	80	626	626	663	507	723	373	603	603	635	494	691	361	577	577	604	480	656	348
	85	661	661	666	614	725	481	637	637	637	600	693	468	610	610	606	586	658	451
	90	696	696	696	696	727	582	671	671	670	670	695	569	642	642	642	642	660	554
22500	75	610	569	670	424	728	268	584	555	640	411	695	256	555	541	608	398	659	243
	80	645	645	673	539	731	391	621	621	644	526	699	379	594	594	612	511	663	366
	85	682	682	675	658	734	510	656	656	646	642	701	493	628	628	614	614	665	478
	90	717	717	717	717	735	622	690	690	690	690	703	609	659	659	659	659	667	594
CFM	ENT DB (F)	Ambient Temperature 115																	
		Entering Wet Bulb																	
		61		67		73		61		67		73		61		67		73	
		CAP	SHC	CAP	SHC	CAP	SHC	CAP	SHC	CAP	SHC	CAP	SHC	CAP	SHC	CAP	SHC	CAP	SHC
10000	75	452	341	504	271	559	198												
	80	459	400	504	328	560	256												
	85	463	453	509	385	561	313												
	90	488	488	514	443	564	370												
14000	75	489	405	540	312	591	210												
	80	496	484	543	388	594	289												
	85	525	525	545	463	593	367												
	90	553	553	556	541	598	441												
17500	75	508	456	558	343	607	218												
	80	531	531	561	433	610	316												
	85	562	562	564	526	612	408												
	90	591	591	591	591	614	499												
20000	75	517	491	567	363	614	224												
	80	550	550	570	465	618	334												
	85	581	581	573	570	620	435												
	90	610	610	610	610	622	539												
22500	75	525	525	574	383	620	230												
	80	565	565	578	496	623	353												
	85	597	597	580	580	626	462												
	90	625	625	625	625	627	578												

Note: Cooling capacity will be slightly different for 200V or 575V units. Please see TOPSS™ for corrected performance



Performance Data

Air-Cooled - Gross Cooling Capacities

Table 28. Gross Cooling Capacities (MBh) — 55 Ton Air-Cooled — Standard Capacity — R-410A

CFM	ENT DB (F)	Ambient Temperature																	
		85						95						105					
		61		67		73		Entering Wet Bulb						61		67		73	
		CAP	SHC	CAP	SHC	CAP	SHC	CAP	SHC	CAP	SHC	CAP	SHC	CAP	SHC	CAP	SHC	CAP	SHC
10000	75	538	388	603	318	671	245	516	376	577	306	641	232	490	361	549	292	607	218
	80	545	448	603	376	672	303	522	435	577	363	642	290	495	420	547	349	609	276
	85	550	507	607	434	671	361	528	493	581	421	643	348	500	477	552	406	610	333
	90	561	561	611	493	675	418	542	542	586	479	645	405	520	520	554	463	612	390
14000	75	591	458	653	362	718	259	564	444	622	348	683	245	533	427	588	332	644	230
	80	600	541	654	440	720	338	573	526	626	426	685	325	539	509	592	410	646	309
	85	613	613	659	517	720	417	590	590	629	502	686	403	564	564	595	485	647	387
	90	646	646	669	600	723	494	622	622	639	585	689	479	594	594	605	568	650	462
17500	75	618	512	681	395	741	267	589	496	648	381	704	253	556	480	611	365	662	238
	80	630	616	683	489	743	365	603	596	650	474	706	351	573	573	614	457	664	335
	85	662	662	686	582	743	462	636	636	653	567	707	447	605	605	616	549	666	431
	90	697	697	699	684	746	553	668	668	669	663	709	537	636	636	636	636	667	519
20000	75	632	548	694	417	752	273	601	532	659	403	713	259	567	515	621	387	670	243
	80	653	653	697	521	754	383	626	626	663	506	716	369	595	595	624	488	672	353
	85	689	689	699	627	755	491	660	660	665	611	717	476	627	627	627	594	674	459
	90	723	723	723	723	757	593	692	692	692	692	718	577	657	657	656	656	675	559
22500	75	643	583	704	439	760	278	611	567	669	424	721	264	576	550	629	406	677	249
	80	674	674	707	553	762	401	645	645	672	537	723	387	612	612	632	519	679	371
	85	710	710	709	671	764	520	679	679	674	655	724	505	644	644	635	633	679	483
	90	743	743	743	743	765	632	710	710	710	710	725	616	672	672	671	671	680	598
	ENT DB (F)	Ambient Temperature 115																	
		Entering Wet Bulb																	
CFM		61		67		73													
		CAP	SHC	CAP	SHC	CAP	SHC												
10000	75	462	346	517	277	570	203												
	80	468	404	516	333	572	260												
	85	476	463	521	390	572	317												
	90	496	496	525	448	576	374												
14000	75	501	411	551	316	601	214												
	80	512	494	555	393	604	293												
	85	535	535	558	468	604	371												
	90	563	563	566	550	607	444												
17500	75	521	462	571	348	616	221												
	80	542	542	574	438	618	318												
	85	572	572	576	531	619	413												
	90	599	599	599	599	621	500												
20000	75	531	497	580	370	623	227												
	80	561	561	583	470	625	336												
	85	591	591	585	575	626	437												
	90	616	616	616	616	626	539												
22500	75	538	531	587	388	628	232												
	80	576	576	590	500	629	354												
	85	605	605	592	592	630	463												
	90	627	627	627	627	630	578												

Note: Cooling capacity will be slightly different for 200V units. Please see TOPSS™ for corrected performance

Table 29. Gross Cooling Capacities (MBh) – 55 Ton Air-Cooled – High Efficiency – R-410A

CFM	ENT DB (F)	Ambient Temperature																	
		85						95						105					
		Entering Wet Bulb																	
		61		67		73		61		67		73		61		67		73	
CAP	SHC	CAP	SHC	CAP	SHC	CAP	SHC	CAP	SHC	CAP	SHC	CAP	SHC	CAP	SHC	CAP	SHC		
10000	75	542	390	608	321	675	247	520	378	581	308	646	234	494	364	553	293	612	220
	80	549	450	607	378	676	306	526	437	581	365	647	292	500	422	551	350	613	278
	85	554	509	611	436	677	363	532	495	586	423	647	350	503	479	556	408	613	335
	90	564	564	615	495	680	420	545	545	590	481	650	407	523	523	561	466	617	392
14000	75	595	460	659	364	725	262	568	446	627	350	690	248	538	430	594	335	651	233
	80	604	543	659	443	727	342	577	529	630	429	693	328	543	511	596	412	654	312
	85	617	617	664	519	727	420	594	594	634	504	693	406	567	567	599	487	654	390
	90	650	650	674	602	731	497	625	625	644	587	697	483	598	598	610	571	659	466
17500	75	623	514	686	397	750	271	593	499	653	383	713	257	560	482	616	367	671	241
	80	638	620	689	492	753	369	607	599	656	476	716	355	577	577	619	459	675	339
	85	667	667	692	585	753	466	640	640	659	569	719	452	610	610	622	552	677	434
	90	702	702	705	688	758	557	674	674	675	667	721	542	642	642	642	642	680	525
20000	75	637	551	700	420	763	277	606	535	665	405	724	263	571	517	627	389	681	247
	80	657	657	703	524	766	388	630	630	669	508	728	374	599	599	630	491	685	358
	85	694	694	706	630	768	497	666	666	672	614	730	479	633	633	633	597	688	465
	90	730	730	730	730	771	599	700	700	700	700	733	583	666	666	666	666	690	565
22500	75	648	586	710	442	772	283	616	570	675	427	733	269	580	552	635	408	688	253
	80	679	679	714	556	776	406	650	650	679	540	737	392	617	617	639	522	693	376
	85	717	717	717	674	779	526	686	686	682	658	740	511	652	652	642	639	696	490
	90	754	754	753	753	781	639	722	722	721	721	742	623	685	685	685	685	698	605
	ENT DB (F)	Ambient Temperature																	
		115																	
		Entering Wet Bulb																	
		61		67		73		61		67		73		61		67		73	
CFM	CAP	SHC	CAP	SHC	CAP	SHC	CAP	SHC	CAP	SHC	CAP	SHC	CAP	SHC	CAP	SHC	CAP	SHC	
10000	75	465	348	519	278	575	205												
	80	472	406	519	335	576	262												
	85	468	463	524	392	578	319												
	90	499	499	528	449	580	376												
14000	75	504	412	554	318	609	216												
	80	515	495	559	395	612	296												
	85	538	538	562	470	612	374												
	90	567	567	573	553	616	448												
17500	75	524	463	575	350	625	225												
	80	545	545	579	441	629	322												
	85	576	576	582	533	632	418												
	90	606	606	606	606	634	506												
20000	75	534	498	585	372	634	231												
	80	565	565	589	472	638	341												
	85	597	597	591	577	641	447												
	90	627	627	627	627	643	546												
22500	75	542	533	592	390	640	236												
	80	581	581	596	503	645	359												
	85	613	613	599	599	648	470												
	90	644	644	644	644	650	586												

Note: Cooling capacity will be slightly different for 200V units. Please see TOPSS™ for corrected performance



Performance Data

Air-Cooled - Gross Cooling Capacities

Table 30. Gross Cooling Capacities (MBh)— 55 Ton Air-Cooled — eFlex™ Variable Speed Compressor — R-410A

CFM	ENT DB (F)	Ambient Temperature																		
		85						95						105						
		61			67			73			Entering Wet Bulb						61		67	
CAP	SHC	CAP	SHC	CAP	SHC	CAP	SHC	CAP	SHC	CAP	SHC	CAP	SHC	CAP	SHC	CAP	SHC	CAP	SHC	
10000	75	536	387	599	317	666	244	515	376	576	305	640	232	494	364	550	293	611	220	
	80	543	447	599	374	667	302	522	435	576	363	641	290	500	422	551	350	612	278	
	85	545	505	604	433	667	359	528	493	581	421	641	347	501	478	556	408	613	335	
	90	559	559	607	491	670	416	542	542	585	479	644	404	523	523	560	466	616	392	
14000	75	587	456	650	360	714	257	563	443	623	348	683	245	537	430	593	334	650	232	
	80	596	539	651	439	716	337	572	526	625	426	686	325	539	513	595	412	652	311	
	85	610	610	654	515	716	416	589	589	628	501	686	403	567	567	598	487	652	390	
	90	642	642	664	598	719	493	621	621	638	584	689	480	597	597	609	570	656	465	
17500	75	613	510	676	393	738	267	588	496	647	380	705	254	559	482	615	367	669	241	
	80	629	613	678	487	741	365	605	596	649	473	708	352	576	576	618	459	672	338	
	85	658	658	681	580	742	461	635	635	652	566	710	448	609	609	620	551	674	434	
	90	693	693	699	682	745	552	668	668	668	668	712	538	641	641	640	640	676	523	
20000	75	627	546	689	415	750	272	600	532	658	401	716	260	571	517	625	387	678	246	
	80	648	648	692	520	753	383	624	624	662	506	719	371	598	598	629	490	682	357	
	85	685	685	694	625	755	491	660	660	664	611	721	478	632	632	631	596	684	463	
	90	720	720	720	720	757	593	694	694	693	693	723	579	664	664	663	663	686	564	
22500	75	638	581	699	435	759	278	610	567	668	422	724	265	580	552	634	407	686	252	
	80	669	669	702	551	762	402	644	644	671	537	728	389	616	616	637	521	689	375	
	85	707	707	705	669	764	520	680	680	674	653	730	507	650	650	640	630	691	492	
	90	742	742	742	742	766	633	714	714	714	714	731	619	682	682	682	682	692	603	
CFM	ENT DB (F)	Ambient Temperature																		
		115																		
		61			67			73												
CAP	SHC	CAP	SHC	CAP	SHC	CAP	SHC	CAP	SHC	CAP	SHC	CAP	SHC	CAP	SHC					
10000	75	471	351	524	280	580	207													
	80	477	409	524	337	581	264													
	85	477	464	529	394	582	321													
	90	503	503	531	451	585	378													
14000	75	510	415	562	321	614	218													
	80	516	496	564	397	616	297													
	85	542	542	567	472	616	375													
	90	571	571	569	552	620	450													
17500	75	530	466	581	352	630	226													
	80	550	550	584	443	633	324													
	85	580	580	586	536	635	419													
	90	610	610	610	610	637	507													
20000	75	540	501	590	372	638	232													
	80	570	570	594	474	642	342													
	85	601	601	596	580	643	447													
	90	630	630	630	630	645	547													
22500	75	548	535	598	392	644	237													
	80	586	586	601	505	648	360													
	85	617	617	603	603	649	471													
	90	646	646	646	646	650	586													

Note: Cooling capacity will be slightly different for 200V or 575V units. Please see TOPSS™ for corrected performance

Table 31. Gross Cooling Capacities (MBh) — 60 Ton Air-Cooled — Standard Capacity — R-410A

CFM	ENT DB (F)	Ambient Temperature																	
		85						95						105					
		Entering Wet Bulb																	
		61		67		73		61		67		73		61		67		73	
CAP	SHC	CAP	SHC	CAP	SHC	CAP	SHC	CAP	SHC	CAP	SHC	CAP	SHC	CAP	SHC	CAP	SHC		
14000	75	625	475	699	379	777	278	595	459	667	364	741	264	563	443	631	348	701	248
	80	631	560	700	457	778	359	602	544	668	442	742	344	570	527	633	426	702	328
	85	637	637	702	536	780	437	613	613	670	521	744	422	586	586	634	504	704	406
	90	672	672	708	621	781	515	648	648	676	605	746	500	620	620	641	589	706	484
18000	75	660	538	734	417	811	290	628	522	699	401	773	276	592	504	660	385	729	260
	80	671	651	734	516	812	390	639	628	700	500	774	376	604	604	661	483	731	359
	85	699	699	738	613	814	488	672	672	703	597	776	474	641	641	664	579	733	457
	90	738	738	746	725	816	587	710	710	715	703	777	571	678	678	677	677	735	554
21000	75	678	582	752	443	828	298	645	565	715	427	788	283	607	547	674	410	743	267
	80	694	694	754	557	829	412	665	665	717	540	790	398	633	633	677	522	745	381
	85	735	735	757	667	831	525	705	705	720	650	792	510	672	672	679	632	747	494
	90	776	776	775	775	833	636	745	745	745	745	794	620	711	711	710	710	749	603
24000	75	692	624	766	468	841	305	657	607	728	452	800	290	619	588	686	435	754	274
	80	721	721	769	594	842	433	691	691	731	578	802	419	657	657	688	560	756	402
	85	764	764	771	719	844	560	733	733	733	702	804	545	697	697	691	684	758	529
	90	806	806	806	806	846	683	774	774	773	773	806	668	737	737	737	737	760	650
27000	75	703	664	778	492	850	311	668	647	739	476	809	297	628	628	695	459	762	281
	80	744	744	780	631	852	453	713	713	741	614	810	439	677	677	698	596	763	422
	85	788	788	782	769	854	594	755	755	744	744	813	580	718	718	701	701	766	563
	90	830	830	830	830	855	729	797	797	796	796	815	714	758	758	758	758	768	696
14000	ENT DB (F)	Ambient Temperature 115																	
		Entering Wet Bulb																	
		61		67		73		61		67		73		61		67		73	
		CAP	SHC	CAP	SHC	CAP	SHC	CAP	SHC	CAP	SHC	CAP	SHC	CAP	SHC	CAP	SHC	CAP	SHC
14000	75	536	429	596	332	659	232												
	80	542	513	596	410	660	312												
	85	561	561	599	487	662	389												
	90	592	592	607	572	664	467												
18000	75	560	488	621	368	684	243												
	80	576	576	622	466	686	343												
	85	610	610	625	561	688	440												
	90	644	644	644	644	690	536												
21000	75	572	530	633	394	696	250												
	80	602	602	636	504	698	364												
	85	638	638	638	614	701	476												
	90	674	674	674	674	703	585												
24000	75	582	571	643	418	706	257												
	80	623	623	646	541	708	385												
	85	660	660	648	648	710	512												
	90	698	698	697	697	712	632												
27000	75	590	590	651	442	713	264												
	80	640	640	653	577	714	405												
	85	679	679	656	656	717	546												
	90	717	717	716	716	719	678												

Note: Cooling capacity will be slightly different for 200V units. Please see TOPSS™ for corrected performance

Performance Data

Air-Cooled - Gross Cooling Capacities

Table 32. Gross Cooling Capacities (MBh)— 60 Ton Air-Cooled – High Capacity – R-410A

CFM	ENT DB (F)	Ambient Temperature																	
		85						95						105					
		Entering Wet Bulb																	
		61		67		73		61		67		73		61		67		73	
CAP	SHC	CAP	SHC	CAP	SHC	CAP	SHC	CAP	SHC	CAP	SHC	CAP	SHC	CAP	SHC	CAP	SHC		
14000	75	653	489	731	393	811	292	622	473	697	377	774	277	590	456	660	360	733	260
	80	659	574	731	471	812	372	629	558	699	456	775	357	596	540	662	439	734	340
	85	668	657	734	550	814	450	635	635	701	535	777	435	608	608	664	517	736	418
	90	696	696	738	635	815	528	670	670	706	619	779	513	642	642	670	602	738	496
18000	75	691	553	769	431	848	303	658	537	732	415	808	288	621	518	691	397	763	272
	80	701	665	769	530	849	404	666	647	733	514	809	388	633	623	692	496	765	371
	85	725	725	772	628	851	502	697	697	736	611	811	486	666	666	695	592	767	469
	90	765	765	784	742	852	600	736	736	749	725	813	585	703	703	708	698	768	567
21000	75	711	598	788	458	866	311	676	580	750	441	825	296	638	561	707	423	778	279
	80	721	721	789	572	867	426	692	692	752	555	826	410	659	659	709	536	780	393
	85	763	763	793	682	869	538	733	733	755	665	828	523	698	698	712	646	782	506
	90	805	805	805	805	870	650	773	773	773	773	830	634	738	738	737	737	784	616
24000	75	726	640	803	483	879	318	690	622	764	466	837	303	650	603	720	448	789	286
	80	751	751	805	610	880	447	719	719	766	593	839	431	684	684	722	574	791	414
	85	794	794	808	734	882	573	762	762	769	717	841	558	725	725	725	698	793	541
	90	837	837	836	836	884	698	803	803	803	803	842	681	765	765	765	765	795	663
27000	75	738	680	815	507	889	324	701	662	775	490	847	309	660	643	730	472	798	293
	80	775	775	817	647	891	467	742	742	777	629	848	451	705	705	732	610	799	434
	85	820	820	820	785	892	607	786	786	780	767	850	592	747	747	735	735	802	575
	90	862	862	862	862	894	744	827	827	827	827	852	727	788	788	787	787	804	709
CFM	ENT DB (F)	Ambient Temperature																	
		115																	
		Entering Wet Bulb																	
		61		67		73		61		67		73		61		67		73	
CAP	SHC	CAP	SHC	CAP	SHC	CAP	SHC	CAP	SHC	CAP	SHC	CAP	SHC	CAP	SHC	CAP	SHC		
14000	75	561	441	624	344	690	244												
	80	567	525	626	423	691	323												
	85	582	582	627	500	693	401												
	90	614	614	634	584	695	478												
18000	75	588	501	651	380	716	254												
	80	599	599	652	479	718	354												
	85	634	634	655	574	720	452												
	90	669	669	669	669	721	548												
21000	75	601	544	664	406	729	262												
	80	627	627	666	517	731	376												
	85	663	663	669	627	733	488												
	90	700	700	700	700	735	597												
24000	75	612	585	675	430	739	268												
	80	649	649	677	554	741	396												
	85	687	687	680	678	743	523												
	90	725	725	725	725	745	644												
27000	75	621	621	684	454	747	275												
	80	667	667	686	590	748	416												
	85	707	707	689	689	751	557												
	90	745	745	745	745	753	689												

Note: Cooling capacity will be slightly different for 200V units. Please see TOPSS™ for corrected performance

Performance Data

Air-Cooled - Gross Cooling Capacities

Table 33. Gross Cooling Capacities (MBh) – 60 Ton Air-Cooled – High Efficiency – R-410A

CFM	ENT DB (F)	Ambient Temperature																			
		85						95						105							
		61			67			73			Entering Wet Bulb						61		67		73
		CAP	SHC	CAP	SHC	CAP	SHC	CAP	SHC	CAP	SHC	CAP	SHC	CAP	SHC	CAP	SHC	CAP	SHC	CAP	SHC
14000	75	653	489	731	393	811	292	622	473	697	377	774	277	590	456	660	360	733	260		
	80	659	574	731	471	812	372	629	558	698	456	775	357	596	540	661	439	734	340		
	85	668	657	734	550	814	450	635	635	701	535	777	435	608	608	664	517	736	418		
	90	696	696	738	635	815	528	670	670	706	619	779	513	642	642	670	602	738	496		
18000	75	691	553	769	431	848	303	658	537	732	415	808	288	621	518	691	397	763	271		
	80	701	665	770	531	849	404	666	647	733	514	809	388	633	623	692	497	765	371		
	85	725	725	772	628	851	502	697	697	736	611	811	486	666	666	695	592	767	469		
	90	765	765	784	742	852	600	736	736	749	725	813	585	703	703	708	698	768	567		
21000	75	711	598	788	458	866	311	676	580	750	441	825	296	638	561	707	423	778	279		
	80	721	721	789	572	867	426	692	692	752	555	826	410	659	659	709	536	780	393		
	85	763	763	793	682	869	538	733	733	754	665	828	523	698	698	712	646	782	506		
	90	805	805	805	805	870	650	773	773	773	773	830	634	738	738	737	737	784	616		
24000	75	726	640	803	483	879	318	690	622	764	466	837	303	650	603	720	448	789	286		
	80	751	751	805	610	880	447	719	719	766	593	839	431	684	684	722	574	791	414		
	85	794	794	808	734	882	573	762	762	769	717	841	558	725	725	725	698	793	541		
	90	837	837	836	836	884	698	803	803	803	803	842	681	765	765	765	765	795	663		
27000	75	738	680	815	507	889	324	701	662	775	490	847	309	660	643	730	472	798	293		
	80	775	775	817	647	891	467	742	742	777	629	848	451	705	705	732	610	799	434		
	85	820	820	820	785	892	607	786	786	780	767	850	592	747	747	735	735	802	575		
	90	862	862	862	862	894	744	827	827	827	827	852	727	788	788	787	787	804	709		
CFM	ENT DB (F)	Ambient Temperature																			
		115																			
		Entering Wet Bulb																			
		61		67		73															
		CAP	SHC	CAP	SHC	CAP	SHC														
14000	75	561	441	624	344	690	244														
	80	567	525	626	423	691	323														
	85	582	582	627	500	693	401														
	90	614	614	634	585	695	478														
18000	75	587	501	651	380	716	254														
	80	599	599	652	479	718	354														
	85	634	634	655	574	720	452														
	90	669	669	669	669	721	548														
21000	75	601	544	664	406	729	262														
	80	627	627	666	517	731	376														
	85	663	663	669	627	733	488														
	90	700	700	700	700	735	597														
24000	75	612	585	675	430	739	268														
	80	649	649	677	554	741	396														
	85	687	687	680	678	743	523														
	90	725	725	725	725	745	644														
27000	75	621	621	683	454	747	275														
	80	668	667	686	590	748	416														
	85	707	707	689	689	751	557														
	90	745	745	745	745	753	689														

Note: Cooling capacity will be slightly different for 200V units. Please see TOPSS™ for corrected performance

Performance Data
Air-Cooled - Gross Cooling Capacities
Table 34. Gross Cooling Capacities (MBh)— 60 Ton Air-Cooled — eFlex™ Variable Speed Compressor — R-410A

CFM	ENT DB (F)	Ambient Temperature																	
		85						95						105					
		Entering Wet Bulb																	
		61		67		73		61		67		73		61		67		73	
CAP	SHC	CAP	SHC	CAP	SHC	CAP	SHC	CAP	SHC	CAP	SHC	CAP	SHC	CAP	SHC	CAP	SHC		
14000	75	653	489	728	392	808	291	627	475	699	378	775	277	600	461	668	364	740	263
	80	658	574	729	471	809	371	632	560	699	457	776	357	605	545	669	443	741	343
	85	666	648	731	549	810	449	642	632	702	535	778	435	616	616	672	521	743	421
	90	694	694	736	634	812	527	672	672	707	620	779	513	649	649	677	605	744	499
18000	75	689	553	765	430	844	302	661	538	733	415	809	289	631	523	699	401	770	274
	80	695	662	766	529	845	403	669	644	734	515	810	389	641	626	701	500	772	374
	85	723	723	769	627	847	501	698	698	737	611	812	487	672	672	703	596	774	472
	90	763	763	781	740	848	599	736	736	750	726	813	585	709	709	716	698	775	569
21000	75	709	597	785	456	862	310	678	581	751	442	826	296	647	566	715	427	786	282
	80	725	712	786	570	864	425	693	693	752	555	827	411	666	666	717	540	787	396
	85	761	761	789	681	866	537	733	733	755	665	829	523	705	705	720	649	789	508
	90	802	802	808	795	867	649	774	774	774	774	831	635	744	744	743	743	791	619
24000	75	724	638	800	481	876	317	692	623	764	467	838	303	660	607	728	452	797	289
	80	748	748	801	608	877	446	720	720	766	593	840	432	691	691	730	577	799	417
	85	791	791	804	733	879	573	762	762	769	717	842	559	732	732	732	701	801	544
	90	834	834	833	833	881	697	804	804	804	804	844	682	772	772	771	771	803	666
27000	75	735	679	811	505	887	324	703	663	775	491	848	310	669	647	738	475	806	295
	80	772	772	813	645	888	466	743	743	778	629	850	452	712	712	740	613	808	437
	85	817	817	816	783	890	607	786	786	780	766	852	593	754	754	742	741	811	578
	90	860	860	859	859	892	743	829	829	828	828	854	728	795	795	794	794	813	712
CFM	ENT DB (F)	Ambient Temperature 115																	
		Entering Wet Bulb																	
		61		67		73		61		67		73		61		67		73	
		CAP	SHC	CAP	SHC	CAP	SHC	CAP	SHC	CAP	SHC	CAP	SHC	CAP	SHC	CAP	SHC	CAP	SHC
14000	75	578	450	641	351	707	250												
	80	583	533	642	430	708	330												
	85	596	596	644	508	709	407												
	90	628	628	648	591	711	485												
18000	75	606	510	668	387	734	261												
	80	617	611	669	486	735	360												
	85	648	648	671	581	737	458												
	90	682	682	682	682	738	555												
21000	75	620	552	682	413	747	268												
	80	641	641	684	525	749	382												
	85	677	677	686	634	751	494												
	90	714	714	714	714	752	603												
24000	75	630	593	693	437	758	275												
	80	664	664	695	562	759	403												
	85	702	702	697	686	761	529												
	90	739	739	739	739	763	650												
27000	75	639	632	702	461	766	281												
	80	683	683	704	598	767	423												
	85	722	722	706	706	769	563												
	90	760	760	759	759	770	696												

Note: Cooling capacity will be slightly different for 200V or 575V units. Please see TOPSS™ for corrected performance

Table 37. Gross Cooling Capacities (MBh) – 70 Ton Air-Cooled – eFlex™ Variable Speed Compressor – R-410A

CFM	ENT DB (F)	Ambient Temperature																	
		85						95						105					
		Entering Wet Bulb																	
		61		67		73		61		67		73		61		67		73	
CAP	SHC	CAP	SHC	CAP	SHC	CAP	SHC	CAP	SHC	CAP	SHC	CAP	SHC	CAP	SHC	CAP	SHC		
16000	75	762	575	846	459	933	337	732	559	812	443	895	322	701	543	777	427	855	306
	80	769	679	847	552	934	432	739	662	812	536	897	416	708	646	778	520	857	400
	85	782	752	851	645	936	525	754	733	816	629	899	509	726	714	781	612	859	493
	90	814	814	857	749	938	617	787	787	823	732	901	602	760	760	788	715	860	585
20000	75	797	640	882	497	967	348	765	623	845	481	927	333	732	606	807	464	884	316
	80	808	756	884	612	969	464	777	735	847	595	928	448	746	714	808	578	886	432
	85	837	837	887	724	971	577	808	808	850	707	931	561	778	778	811	689	888	544
	90	881	881	898	838	973	689	851	851	865	816	932	673	819	819	829	794	890	656
22000	75	812	671	896	515	980	353	777	653	857	499	938	337	743	636	818	482	894	321
	80	828	789	897	639	981	479	796	767	859	622	940	463	764	746	819	605	896	446
	85	863	863	900	761	983	602	833	833	862	743	942	586	801	801	823	725	899	569
	90	908	908	920	876	985	723	876	876	885	854	944	707	843	843	849	831	901	690
24000	75	823	700	907	533	990	358	788	682	868	516	947	342	752	664	827	499	903	326
	80	846	821	908	666	991	493	814	800	869	649	949	477	777	777	828	631	905	461
	85	886	886	912	797	994	626	854	854	873	779	952	610	820	820	832	761	907	593
	90	931	931	939	913	995	757	899	899	898	898	953	740	864	864	863	863	909	723
26000	75	833	728	916	550	998	362	797	710	877	533	955	347	760	692	835	516	910	331
	80	858	858	918	692	1000	507	826	826	879	675	957	491	793	793	838	657	912	475
	85	905	905	922	832	1002	650	873	873	882	814	960	634	838	838	841	795	915	617
	90	952	952	952	952	1004	789	918	918	918	918	962	772	882	882	881	881	917	755
CFM	ENT DB (F)	Ambient Temperature 115																	
		Entering Wet Bulb																	
		61		67		73		61		67		73		61		67		73	
		CAP	SHC	CAP	SHC	CAP	SHC	CAP	SHC	CAP	SHC	CAP	SHC	CAP	SHC	CAP	SHC	CAP	SHC
16000	75	677	531	746	413	818	291												
	80	679	630	746	506	819	385												
	85	701	701	750	597	821	477												
	90	736	736	757	700	822	569												
20000	75	704	592	772	449	843	301												
	80	719	696	773	562	844	416												
	85	751	751	776	672	846	528												
	90	789	789	796	773	848	639												
22000	75	713	621	782	467	852	306												
	80	735	728	783	589	853	430												
	85	771	771	786	708	855	553												
	90	811	811	810	810	857	673												
24000	75	722	649	790	484	859	310												
	80	749	749	792	615	861	445												
	85	789	789	795	744	863	577												
	90	829	829	829	829	865	705												
26000	75	729	676	797	500	866	315												
	80	763	763	799	640	867	459												
	85	805	805	802	773	869	601												
	90	845	845	845	845	871	737												

Note: Cooling capacity will be slightly different for 200V or 575V units. Please see TOPSS™ for corrected performance



Performance Data

Air-Cooled - Gross Cooling Capacities

Table 38. Gross Cooling Capacities (MBh) — 75 Ton Air-Cooled — Standard Capacity — R-410A

CFM	ENT DB (F)	Ambient Temperature																	
		85						95						105					
		61		67		73		61		67		73		61		67		73	
CAP	SHC	CAP	SHC	CAP	SHC	CAP	SHC	CAP	SHC	CAP	SHC	CAP	SHC	CAP	SHC	CAP	SHC	CAP	SHC
16000	75	827	610	919	492	1012	366	790	590	878	472	966	348	753	571	835	452	917	328
	80	833	714	920	586	1013	463	797	694	879	567	967	444	761	675	836	547	918	424
	85	844	814	924	681	1014	557	805	788	883	662	969	538	771	764	839	641	920	517
	90	870	870	928	786	1016	651	840	840	888	766	971	631	807	807	846	745	922	611
20000	75	868	678	961	531	1047	376	829	658	916	511	998	357	788	637	869	491	945	337
	80	880	810	962	648	1048	494	841	789	916	627	999	475	801	769	870	607	946	454
	85	899	899	964	762	1050	608	865	865	920	741	1001	589	828	828	873	719	948	568
	90	945	945	977	896	1052	723	909	909	934	876	1003	703	871	871	888	854	950	683
22000	75	884	709	976	550	1059	381	843	688	930	530	1009	362	801	667	881	509	955	342
	80	900	857	976	676	1060	508	853	830	930	656	1010	489	815	802	882	635	956	468
	85	928	928	980	800	1062	633	892	892	934	778	1012	613	853	853	886	756	957	592
	90	975	975	996	950	1064	758	937	937	946	921	1013	738	896	896	896	896	959	716
24000	75	898	739	988	567	1069	385	855	717	941	547	1017	366	812	696	891	526	962	346
	80	911	892	989	704	1070	522	868	868	942	684	1019	503	829	829	893	662	963	482
	85	953	953	993	836	1072	656	915	915	946	815	1020	637	875	875	896	792	965	616
	90	1000	1000	1007	989	1073	791	960	960	960	960	1021	770	918	918	917	917	966	748
26000	75	910	768	999	584	1077	389	866	746	951	564	1024	370	821	724	900	543	968	350
	80	925	925	1001	731	1078	536	887	887	953	710	1026	516	847	847	902	687	969	496
	85	975	975	1004	871	1079	680	936	936	956	850	1027	660	893	893	905	827	970	639
	90	1022	1022	1021	1021	1081	823	980	980	980	980	1028	802	935	935	935	935	972	779
27000	75	915	782	1004	593	1080	391	871	760	955	572	1028	372	825	738	904	551	971	352
	80	935	935	1005	744	1081	542	897	897	957	722	1029	523	856	856	906	700	972	502
	85	985	985	1008	889	1083	691	945	945	960	867	1030	671	902	902	909	844	973	651
	90	1031	1031	1031	1031	1084	838	989	989	989	989	1031	817	943	943	942	942	974	795
CFM	ENT DB (F)	Ambient Temperature																	
		115																	
		61		67		73		61		67		73		61		67		73	
CAP	SHC	CAP	SHC	CAP	SHC	CAP	SHC	CAP	SHC	CAP	SHC	CAP	SHC	CAP	SHC	CAP	SHC	CAP	SHC
16000	75	727	558	796	435	868	309												
	80	733	660	798	529	869	404												
	85	743	743	800	623	871	497												
	90	778	778	806	725	873	591												
20000	75	755	620	823	471	891	318												
	80	763	745	823	587	893	434												
	85	795	795	827	698	894	547												
	90	833	833	839	823	896	661												
22000	75	765	649	834	489	899	322												
	80	777	777	835	614	901	448												
	85	815	815	839	735	902	571												
	90	855	855	855	855	903	694												
24000	75	774	677	843	506	906	326												
	80	794	794	845	640	907	461												
	85	835	835	848	770	908	595												
	90	874	874	873	873	909	725												
26000	75	782	705	850	522	911	329												
	80	809	809	852	665	912	475												
	85	851	851	855	805	912	618												
	90	888	888	888	888	913	756												
27000	75	785	718	854	531	913	331												
	80	816	816	856	678	914	481												
	85	858	858	858	822	914	629												
	90	895	895	894	894	915	772												

Note: Cooling capacity will be slightly different for 200V units. Please see TOPSS™ for corrected performance

Table 39. Gross Cooling Capacities (MBh)— 75 Ton Air-Cooled — High Capacity — R-410A

CFM	ENT DB (F)	Ambient Temperature																							
		85						95						105											
		61		67		73		61		67		73		61		67		73							
		CAP	SHC	CAP	SHC	CAP	SHC	CAP	SHC	CAP	SHC	CAP	SHC	CAP	SHC	CAP	SHC	CAP	SHC						
16000	75	852	624	946	504	1041	378	814	604	904	484	994	358	776	584	860	464	944	338						
	80	857	729	948	600	1042	475	821	708	905	580	995	455	784	688	862	560	945	435						
	85	868	829	951	696	1044	570	826	805	909	675	997	550	793	780	865	654	947	529						
	90	892	892	955	801	1046	664	861	861	914	780	999	644	828	828	870	759	949	623						
20000	75	894	692	990	544	1078	388	855	672	944	524	1028	368	813	651	895	503	973	348						
	80	906	825	990	661	1080	506	866	804	945	641	1029	486	826	783	896	619	975	465						
	85	922	922	993	777	1081	621	887	887	948	756	1031	601	850	850	900	733	976	580						
	90	969	969	1005	912	1083	737	933	933	961	891	1032	717	894	894	914	868	978	695						
22000	75	912	724	1005	563	1091	392	869	703	958	542	1039	372	826	681	908	521	983	352						
	80	927	873	1006	690	1092	521	877	849	959	670	1040	501	838	820	909	648	985	479						
	85	952	952	1010	815	1094	646	915	915	963	793	1042	626	876	876	913	770	986	604						
	90	1000	1000	1025	967	1095	772	961	961	972	941	1044	751	920	920	927	910	987	730						
24000	75	926	754	1019	581	1101	396	882	732	970	560	1048	377	838	710	919	538	991	356						
	80	937	912	1019	719	1102	535	898	884	971	698	1049	514	852	852	920	675	992	493						
	85	978	978	1023	852	1104	670	939	939	975	830	1051	650	898	898	924	807	994	628						
	90	1026	1026	1035	1010	1105	806	986	986	985	985	1052	785	942	942	942	942	995	762						
26000	75	938	784	1030	598	1110	400	893	761	981	577	1055	380	847	738	928	555	997	360						
	80	950	950	1031	746	1111	548	912	912	982	724	1057	528	871	871	930	701	999	507						
	85	1001	1001	1034	887	1112	693	961	961	985	865	1058	673	918	918	933	842	1000	651						
	90	1049	1049	1048	1048	1113	838	1006	1006	1006	1006	1059	816	960	960	960	960	1001	793						
27000	75	944	798	1035	606	1113	402	898	775	985	585	1059	382	851	752	932	563	1000	362						
	80	960	960	1036	759	1114	555	921	921	987	737	1060	535	880	880	934	714	1001	513						
	85	1011	1011	1039	905	1116	705	970	970	990	883	1061	684	926	926	937	859	1002	663						
	90	1059	1059	1058	1058	1117	854	1015	1015	1015	1015	1062	832	968	968	968	968	1003	809						
CFM	ENT DB (F)	Ambient Temperature 115																							
		Entering Wet Bulb						61						67						73					
		CAP	SHC	CAP	SHC	CAP	SHC	CAP	SHC	CAP	SHC	CAP	SHC	CAP	SHC	CAP	SHC	CAP	SHC						
16000	75	750	571	821	446	894	319																		
	80	756	673	822	541	895	415																		
	85	766	761	824	636	897	509																		
	90	799	799	830	739	899	602																		
20000	75	779	633	849	483	919	327																		
	80	786	762	850	599	920	444																		
	85	817	817	853	712	922	559																		
	90	856	856	863	840	923	674																		
22000	75	790	663	860	500	927	331																		
	80	799	799	861	627	928	458																		
	85	838	838	865	749	930	583																		
	90	879	879	878	878	931	707																		
24000	75	800	691	870	518	933	335																		
	80	817	817	872	654	935	472																		
	85	858	858	874	784	936	606																		
	90	898	898	897	897	937	739																		
26000	75	807	719	878	534	939	339																		
	80	832	832	880	679	940	485																		
	85	875	875	882	819	940	629																		
	90	913	913	913	913	941	770																		
27000	75	811	733	881	543	941	341																		
	80	839	839	883	691	942	492																		
	85	883	883	886	836	942	641																		
	90	920	920	919	919	943	785																		

Note: Cooling capacity will be slightly different for 200V units. Please see TOPSS™ for corrected performance

Table 41. Gross Cooling Capacities (MBh)— 90 Ton Air-Cooled — Standard Capacity — R-410A

CFM	EN T DB (F)	Ambient Temperature																	
		85						95						105					
		61		67		73		61		67		73		61		67		73	
		CAP	SHC	CAP	SHC	CAP	SHC	CAP	SHC	CAP	SHC	CAP	SHC	CAP	SHC	CAP	SHC	CAP	SHC
27000	75	1007	799	1106	624	1208	432	965	777	1061	604	1158	413	922	753	1013	582	1104	392
	80	1020	972	1110	766	1212	580	981	950	1066	744	1162	561	938	927	1017	721	1109	540
	85	1052	1052	1116	903	1216	728	1016	1016	1072	881	1167	708	977	977	1024	858	1114	687
	90	1106	1106	1131	1082	1220	862	1069	1069	1088	1060	1171	840	1028	1028	1028	1028	1118	817
32000	75	1037	865	1136	666	1235	444	994	842	1089	645	1183	425	948	818	1038	623	1127	404
	80	1049	1049	1141	825	1240	615	1012	1012	1094	802	1188	596	972	972	1043	778	1133	575
	85	1106	1106	1147	984	1244	783	1068	1068	1100	962	1193	763	1026	1026	1049	938	1137	742
	90	1162	1162	1161	1161	1248	935	1122	1122	1121	1121	1197	913	1078	1078	1077	1077	1142	890
37000	75	1060	927	1158	705	1255	456	1015	903	1109	684	1201	436	967	878	1056	662	1143	416
	80	1090	1090	1163	880	1261	648	1051	1051	1115	857	1207	628	1008	1008	1063	832	1150	607
	85	1149	1149	1169	1061	1265	838	1108	1108	1120	1038	1212	818	1063	1063	1068	1013	1155	797
	90	1205	1205	1205	1205	1269	1005	1162	1162	1162	1162	1216	983	1116	1116	1115	1115	1159	959
42000	75	1077	985	1175	742	1271	467	1032	961	1125	721	1216	447	982	936	1071	699	1156	427
	80	1123	1123	1181	932	1277	680	1081	1081	1131	909	1222	660	1036	1036	1077	884	1164	639
	85	1183	1183	1186	1134	1281	891	1139	1139	1136	1111	1226	871	1092	1092	1082	1082	1168	850
	90	1240	1240	1239	1239	1284	1072	1195	1195	1194	1194	1230	1049	1145	1145	1145	1145	1172	1025
45000	75	1086	1018	1183	763	1279	473	1040	994	1132	742	1223	453	990	968	1078	720	1163	432
	80	1140	1140	1189	962	1280	698	1097	1097	1139	939	1224	678	1051	1051	1085	913	1164	657
	85	1200	1200	1194	1176	1288	922	1155	1155	1144	1144	1233	902	1107	1107	1089	1089	1175	854
	90	1257	1257	1257	1257	1292	1111	1211	1211	1210	1210	1237	1088	1160	1160	1160	1160	1178	1063
CFM	EN T DB (F)	Ambient Temperature																	
		115																	
		61		67		73													
		CAP	SHC	CAP	SHC	CAP	SHC												
27000	75	875	729	961	560	1046	371												
	80	886	886	966	696	1051	518												
	85	936	936	972	833	1056	662												
	90	985	985	984	984	1060	792												
32000	75	899	792	983	601	1066	383												
	80	928	928	990	753	1073	552												
	85	980	980	995	912	1077	719												
	90	1030	1030	1029	1029	1082	864												
37000	75	917	852	1000	639	1081	394												
	80	962	962	1007	806	1088	585												
	85	1014	1014	1012	987	1093	774												
	90	1064	1064	1064	1064	1097	932												
42000	75	930	909	1013	676	1092	404												
	80	988	988	1020	857	1094	616												
	85	1041	1041	1025	1025	1105	801												
	90	1091	1091	1091	1091	1108	998												
45000	75	937	937	1019	697	1098	410												
	80	1001	1001	1026	886	1099	635												
	85	1054	1054	1031	1031	1111	827												
	90	1105	1105	1104	1104	1114	1036												



Performance Data

Air-Cooled - Gross Cooling Capacities

Table 42. Gross Cooling Capacities (MBh)— 90 Ton Air-Cooled — High Capacity and High Efficiency — R-410A

CFM	ENT DB (F)	Ambient Temperature																	
		85						95						105					
		61		67		73		61		67		73		61		67		73	
		CAP	SHC	CAP	SHC	CAP	SHC	CAP	SHC	CAP	SHC	CAP	SHC	CAP	SHC	CAP	SHC	CAP	SHC
27000	75	1071	853	1176	665	1278	459	1028	830	1130	645	1227	440	982	805	1079	623	1173	419
	80	1087	1013	1179	815	1282	616	1046	990	1134	793	1233	596	1001	966	1084	769	1179	576
	85	1122	1122	1184	962	1284	771	1085	1085	1139	940	1235	750	1044	1044	1089	916	1182	727
	90	1176	1176	1200	1122	1287	914	1139	1139	1156	1100	1239	893	1097	1097	1108	1076	1186	870
32000	75	1103	926	1206	712	1307	472	1059	903	1158	691	1254	452	1010	877	1106	669	1197	432
	80	1121	1121	1211	880	1311	656	1082	1082	1163	857	1260	636	1040	1040	1111	833	1204	615
	85	1179	1179	1214	1052	1313	828	1140	1140	1167	1030	1262	806	1096	1096	1116	1005	1207	783
	90	1235	1235	1235	1235	1314	995	1195	1195	1194	1194	1264	974	1150	1150	1149	1149	1210	950
37000	75	1127	997	1229	757	1328	484	1081	972	1179	736	1274	465	1031	946	1125	714	1215	444
	80	1165	1165	1233	942	1332	693	1124	1124	1184	919	1280	673	1079	1079	1131	894	1223	653
	85	1224	1224	1236	1140	1333	882	1182	1182	1188	1117	1282	860	1136	1136	1135	1092	1225	836
	90	1280	1280	1279	1279	1333	1074	1237	1237	1236	1236	1282	1052	1189	1189	1189	1189	1226	1029
42000	75	1145	1064	1246	799	1345	496	1098	1039	1195	780	1289	477	1047	1013	1140	756	1229	456
	80	1200	1200	1250	1002	1349	729	1157	1157	1201	979	1295	710	1111	1111	1146	953	1237	689
	85	1259	1259	1252	1224	1349	934	1216	1216	1203	1201	1296	912	1168	1168	1149	1149	1239	888
	90	1314	1314	1314	1314	1347	1151	1270	1270	1269	1269	1295	1129	1220	1220	1220	1220	1238	1105
45000	75	1154	1103	1255	824	1354	503	1106	1078	1204	805	1297	484	1055	1052	1148	756	1236	463
	80	1217	1217	1259	1037	1357	751	1174	1174	1208	1013	1303	731	1126	1126	1154	988	1245	711
	85	1277	1277	1260	1260	1356	965	1232	1232	1210	1210	1303	943	1183	1183	1156	1156	1245	918
	90	1332	1332	1331	1331	1355	1197	1286	1286	1286	1286	1302	1174	1236	1236	1235	1235	1244	1150
CFM	ENT DB (F)	Ambient Temperature																	
		115																	
		61		67		73													
		CAP	SHC	CAP	SHC	CAP	SHC	CAP	SHC	CAP	SHC	CAP	SHC						
27000	75	934	779	1026	600	1114	397												
	80	954	940	1031	743	1121	554												
	85	1001	1001	1036	890	1124	702												
	90	1052	1052	1057	1050	1128	845												
32000	75	959	851	1050	646	1135	410												
	80	995	995	1056	807	1144	593												
	85	1049	1049	1060	979	1147	757												
	90	1100	1100	1100	1100	1150	925												
37000	75	978	919	1068	691	1152	422												
	80	1031	1031	1074	867	1161	630												
	85	1086	1086	1078	1065	1164	810												
	90	1137	1137	1137	1137	1165	1003												
42000	75	993	985	1082	708	1164	434												
	80	1060	1060	1088	926	1174	667												
	85	1115	1115	1090	1090	1176	861												
	90	1166	1166	1165	1165	1176	1079												
45000	75	1000	1000	1089	728	1170	441												
	80	1075	1075	1094	960	1181	689												
	85	1129	1129	1097	1097	1182	891												
	90	1180	1180	1179	1179	1181	1123												

Performance Data

Air-Cooled - Gross Cooling Capacities

Table 44. Gross Cooling Capacities (MBh) – 115 Ton Air-Cooled – Standard Capacity – R-410A

CFM	ENT DB (F)	Ambient Temperature																	
		85						95						105					
		61		67		73		61		67		73		61		67		73	
CAP	SHC	CAP	SHC	CAP	SHC	CAP	SHC	CAP	SHC	CAP	SHC	CAP	SHC	CAP	SHC	CAP	SHC	CAP	SHC
31000	75	1229	989	1350	770	1468	528	1180	962	1296	746	1409	506	1126	933	1237	721	1345	483
	80	1249	1179	1354	944	1472	713	1201	1153	1301	919	1415	690	1149	1124	1243	891	1352	667
	85	1293	1293	1360	1116	1474	894	1250	1250	1307	1091	1417	869	1202	1202	1249	1063	1355	842
	90	1356	1356	1380	1307	1478	1061	1312	1312	1329	1282	1422	1036	1263	1263	1273	1254	1359	1009
35000	75	1256	1048	1375	808	1491	539	1204	1021	1320	784	1430	517	1148	992	1259	758	1364	493
	80	1282	1267	1380	997	1496	744	1229	1229	1325	971	1436	722	1180	1180	1265	943	1372	698
	85	1340	1340	1384	1190	1498	940	1295	1295	1330	1164	1439	915	1245	1245	1270	1136	1375	888
	90	1404	1404	1404	1404	1500	1127	1358	1358	1358	1358	1442	1102	1306	1306	1306	1306	1379	1075
39000	75	1277	1106	1395	843	1509	549	1224	1078	1338	821	1447	527	1167	1048	1276	795	1380	503
	80	1311	1311	1400	1048	1514	774	1265	1265	1344	1022	1454	752	1214	1214	1283	993	1388	728
	85	1379	1379	1404	1261	1516	984	1332	1332	1349	1235	1456	959	1279	1279	1287	1206	1391	932
	90	1444	1444	1443	1443	1518	1191	1395	1395	1395	1395	1458	1166	1341	1341	1341	1341	1394	1139
43000	75	1294	1161	1411	879	1525	559	1240	1134	1354	855	1461	536	1182	1103	1290	829	1393	512
	80	1343	1343	1416	1098	1529	804	1296	1296	1359	1071	1468	782	1243	1243	1297	1042	1401	758
	85	1412	1412	1420	1331	1531	1028	1363	1363	1363	1304	1470	1002	1309	1309	1301	1275	1404	974
	90	1476	1476	1476	1476	1531	1254	1426	1426	1425	1425	1471	1229	1370	1370	1369	1369	1405	1202
44000	75	1298	1175	1415	887	1528	561	1244	1147	1357	863	1465	539	1185	1117	1293	838	1396	515
	80	1350	1350	1420	1110	1533	812	1302	1302	1363	1083	1471	789	1249	1249	1300	1054	1404	765
	85	1419	1419	1423	1348	1534	1038	1370	1370	1367	1321	1473	1013	1315	1315	1304	1292	1407	985
	90	1484	1484	1483	1483	1534	1270	1433	1433	1432	1432	1474	1245	1376	1376	1376	1376	1408	1217
46000	75	1305	1202	1422	904	1535	566	1251	1174	1363	881	1471	543	1191	1143	1299	855	1401	520
	80	1364	1364	1427	1134	1539	826	1315	1315	1369	1107	1477	804	1262	1262	1306	1078	1410	780
	85	1433	1433	1430	1382	1540	1059	1383	1383	1373	1355	1479	1034	1327	1327	1310	1310	1412	1006
	90	1497	1497	1497	1497	1540	1301	1445	1445	1445	1445	1479	1275	1388	1388	1388	1388	1413	1248

CFM	ENT DB (F)	Ambient Temperature 115											
		Entering Wet Bulb											
		61		67		73		61		67		73	
CAP	SHC	CAP	SHC	CAP	SHC	CAP	SHC	CAP	SHC	CAP	SHC		
31000	75	1069	903	1174	694	1275	457						
	80	1090	1090	1180	861	1283	641						
	85	1151	1151	1186	1033	1288	820						
	90	1210	1210	1209	1209	1291	980						
35000	75	1090	961	1194	731	1292	467						
	80	1128	1128	1200	913	1302	672						
	85	1190	1190	1206	1105	1305	858						
	90	1249	1249	1249	1249	1309	1045						
39000	75	1106	1017	1210	768	1306	477						
	80	1159	1159	1217	962	1316	702						
	85	1222	1222	1221	1175	1320	902						
	90	1281	1281	1281	1281	1322	1109						
43000	75	1120	1071	1222	802	1318	487						
	80	1186	1186	1230	1011	1328	732						
	85	1249	1249	1234	1234	1332	944						
	90	1308	1308	1307	1307	1333	1171						
44000	75	1123	1085	1225	810	1321	489						
	80	1192	1192	1233	1022	1331	739						
	85	1255	1255	1236	1236	1334	954						
	90	1314	1314	1313	1313	1335	1187						
46000	75	1128	1111	1230	828	1325	494						
	80	1203	1203	1238	1046	1336	754						
	85	1266	1266	1241	1241	1339	975						
	90	1325	1325	1324	1324	1339	1217						



Performance Data

Air-Cooled - Gross Cooling Capacities

Table 45. Gross Cooling Capacities (MBh) – 130 Ton Air-Cooled – Standard Capacity – R-410A

CFM	ENT DB (F)	Ambient Temperature																							
		85						95						105											
		Entering Wet Bulb																							
		61		67		73		61		67		73		61		67		73							
		CAP	SHC	CAP	SHC	CAP	SHC	CAP	SHC	CAP	SHC	CAP	SHC	CAP	SHC	CAP	SHC	CAP	SHC						
31000	75	1332	1041	1463	818	1593	574	1278	1012	1406	792	1530	550	1221	981	1343	765	1461	524						
	80	1349	1231	1467	997	1597	759	1297	1202	1410	969	1535	735	1241	1171	1347	939	1467	709						
	85	1381	1381	1474	1169	1601	941	1335	1335	1417	1141	1532	917	1285	1285	1354	1111	1469	890						
	90	1449	1449	1491	1359	1603	1113	1402	1402	1435	1331	1542	1086	1350	1350	1375	1301	1475	1057						
35000	75	1362	1102	1493	857	1620	585	1307	1072	1433	831	1555	560	1247	1041	1368	803	1484	534						
	80	1385	1319	1497	1051	1624	791	1332	1290	1439	1023	1561	767	1274	1258	1374	992	1491	740						
	85	1435	1435	1503	1243	1627	993	1387	1387	1445	1215	1563	966	1333	1333	1380	1184	1495	943						
	90	1504	1504	1526	1461	1630	1180	1455	1455	1470	1433	1567	1153	1399	1399	1399	1399	1498	1123						
39000	75	1387	1160	1517	894	1642	595	1331	1130	1456	868	1575	570	1269	1098	1389	840	1502	544						
	80	1417	1405	1522	1103	1646	822	1358	1358	1461	1074	1581	797	1304	1304	1395	1043	1510	771						
	85	1480	1480	1527	1315	1649	1038	1429	1429	1467	1286	1584	1010	1374	1374	1400	1255	1513	981						
	90	1549	1549	1549	1549	1652	1245	1497	1497	1497	1497	1587	1217	1440	1440	1439	1439	1516	1187						
43000	75	1408	1216	1536	928	1660	605	1350	1186	1473	904	1592	580	1287	1153	1405	876	1517	554						
	80	1443	1443	1541	1152	1664	852	1393	1393	1479	1123	1598	827	1337	1337	1412	1092	1525	801						
	85	1517	1517	1545	1385	1667	1081	1465	1465	1484	1356	1601	1054	1407	1407	1416	1324	1528	1024						
	90	1587	1587	1586	1586	1668	1308	1533	1533	1532	1532	1603	1280	1473	1473	1472	1472	1531	1250						
44000	75	1412	1230	1540	937	1664	607	1354	1200	1477	913	1595	583	1291	1167	1409	883	1521	556						
	80	1452	1452	1545	1165	1668	859	1400	1400	1483	1136	1601	835	1344	1344	1415	1104	1529	808						
	85	1526	1526	1549	1402	1670	1110	1473	1473	1488	1373	1604	1064	1414	1414	1420	1341	1532	1034						
	90	1595	1595	1595	1595	1672	1323	1541	1541	1540	1540	1606	1296	1480	1480	1480	1480	1534	1265						
46000	75	1421	1257	1548	954	1672	612	1362	1227	1485	928	1602	587	1298	1193	1416	900	1527	561						
	80	1468	1468	1553	1189	1676	874	1415	1415	1491	1160	1608	849	1358	1358	1422	1128	1535	823						
	85	1542	1542	1557	1436	1678	1135	1488	1488	1495	1407	1611	1086	1428	1428	1427	1375	1538	1055						
	90	1611	1611	1611	1611	1679	1354	1556	1556	1555	1555	1612	1326	1494	1494	1494	1494	1540	1296						
CFM	ENT DB (F)	Ambient Temperature																							
		115																							
		Entering Wet Bulb																							
		61		67		73																			
		CAP	SHC	CAP	SHC	CAP	SHC																		
31000	75	1160	949	1275	735	1386	496																		
	80	1182	1139	1281	907	1393	680																		
	85	1232	1232	1287	1078	1396	859																		
	90	1294	1294	1309	1268	1402	1025																		
35000	75	1184	1008	1298	773	1407	506																		
	80	1210	1210	1305	959	1415	712																		
	85	1276	1276	1311	1151	1419	914																		
	90	1340	1340	1339	1339	1423	1091																		
39000	75	1204	1064	1317	810	1423	516																		
	80	1246	1246	1324	1009	1432	742																		
	85	1313	1313	1329	1221	1436	948																		
	90	1376	1376	1376	1376	1439	1154																		
43000	75	1220	1119	1332	844	1437	526																		
	80	1276	1276	1339	1058	1446	772																		
	85	1344	1344	1343	1290	1450	991																		
	90	1407	1407	1407	1407	1452	1217																		
44000	75	1224	1132	1335	853	1440	528																		
	80	1283	1283	1342	1070	1449	780																		
	85	1351	1351	1347	1307	1453	1001																		
	90	1414	1414	1414	1414	1455	1232																		
46000	75	1231	1159	1341	870	1446	533																		
	80	1296	1296	1348	1093	1455	794																		
	85	1364	1364	1353	1341	1458	1022																		
	90	1427	1427	1426	1426	1460	1263																		



Performance Data

Table 46. Natural Gas Heating Capacities

Nom. Tons	Gas Heat Module	Heat Input (MBh)	Heat Output (MBh)	Air Temperature Rise Vs Unit Cfm																									
				4000	5000	5760	6000	6284	7000	8000	9000	9792	10000	10682	10830	11200	11750	12000	13500	15000	16129	18000	20000	22500	23040	25000	27000	29377	30000
20	Low	235	192.7	44	36	31	30	28	25	22	20																		
	High	500	410.0			66	63	60	54	47	42																		
25	Low	235	192.7			36	31	30	28	25	22	20	18	18	17	16													
	High	500	410.0			66	63	60	54	47	42	39	38	35	35	34													
30	Low	350	287.0			44	42	38	33	29	27	26	25	24	24	23	22	20											
	High	500	410.0			60	54	47	42	39	38	35	35	34	32	31	28												
40	Low	350	287.0					33	29	27	26	25	24	24	23	22	20	18	16										
	High	850	697.0					66	64	60	59	57	55	54	48	43	40	36											
50-55	Low	500	410.0							38	35	35	34	32	31	28	25	23	21	19	17								
	High	850	697.0							60	59	57	55	54	48	43	40	36	32	29									
60	Low	500	410.0											31	28	25	23	21	19	17	16	15	14						
	High	850	697.0											54	48	43	40	36	32	29	28	26	24						
70	Low	500	410.0													31	28	25	23	21	19	17	16	15	14	13	13		
	High	850	697.0											54	48	43	40	36	32	29	28	26	24	22					
75	Low	500	410.0													31	28	25	23	21	19	17	16	15	14	13	13		
	High	850	697.0											54	48	43	40	36	32	29	28	26	24	22					

Notes:

- All heaters are 81% efficient.
- CFM values below the minimum and above the maximum shown in this table are **not** cULus approved.
- Air temperature rise = heat output (Btu) ÷ (CFM x 1.085).

Table 47. Natural Gas Heating Capacities

Nominal Tons	Gas Heat Module	Heat Input (MBh)	Heat Output (MBh)	Air Temperature Rise vs. Unit CFM									
				CFM									
				28350	30250	32550	34750	37000	39250	41500	43000	46000	
90	High	1000	820	27	25	23	22	20	19	18	18		
105	High	1000	820			23	22	20	19	18	18	16	
115	High	1000	820			23	22	20	19	18	18	16	
130	High	1000	820			23	22	20	19	18	18	16	

Notes:

- All heaters are 81% efficient.
- CFM values below the minimums and above the maximums shown in this table are not cULus approved.
- Air Temperature Rise = Heat Output (Btu) ÷ (CFM x 1.085).

Table 48. Steam Heating Capacities (Q/ITD)^(a)

20 Nominal Ton Unit					25 Nominal Ton Unit				30 Nominal Ton Unit					
Steam Module	Unit Standard Air Volume (CFM)				Steam Module	Unit Standard Air Volume (CFM)			Steam Module	Unit Standard Air Volume (CFM)				
	4000	6000	8000	10000		5000	7500	10000		12500	6000	9000	12000	15000
Low Heat	0.95	1.18	1.37	1.52	Low Heat	1.06	1.33	1.52	1.74	Low Heat	1.18	1.64	1.69	2.00
High Heat	1.94	2.47	2.95	3.31	High Heat	2.20	2.85	3.31	3.65	High Heat	2.47	3.12	3.59	3.95

40 Nominal Ton Unit					50-55 Nominal Ton Unit				60 Nominal Ton Unit					
Steam Module	Unit Standard Air Volume (CFM)				Steam Module	Unit Standard Air Volume (CFM)			Steam Module	Unit Standard Air Volume (CFM)				
	8000	12000	16000	20000		10000	15000	20000		25000	12000	18000	24000	30000
Low Heat	1.61	2.01	2.29	2.60	Low Heat	1.82	2.21	2.60	2.85	Low Heat	2.32	2.81	3.33	3.71
High Heat	3.36	4.28	4.93	5.43	High Heat	3.86	4.79	5.43	5.97	High Heat	3.85	4.84	5.62	6.18

Table 48. Steam Heating Capacities (Q/ITD)^(a) (continued)

70/80 & 75 Nominal Ton Unit					90, 105, 115, 130 Nominal Ton Units				
Steam Module	Unit Standard Air Volume (CFM)				Steam Module	Unit Standard Air Volume (CFM)			
	16000	20000	24000	30000		27000	33000	40000	46000
Low Heat	2.65	2.98	3.33	3.71	Low Heat	5.17	5.70	6.19	6.53
High Heat	4.50	5.10	5.62	6.18	High Heat	8.83	8.80	9.04	9.26

(a) Capacities expressed as MBH (Q) per initial temperature difference (ITD) between the entering air temperature to the steam module and the entering steam temperature. Maximum recommended operating pressure is 35 PSIG.

Table 49. Properties of Steam

Steam Pressure (Psig)	2	5	10	15	20	25	30	40	50
Temperature Of Steam (°F)	219	227	239	250	259	267	274	287	298

Table 50. Electric Heat Air Temperature Rise – 20 to 75 Tons

kW Input	Total MBh	CFM											
		4000	6000	8000	10000	12000	14000	16000	18000	20000	22000	24000	26000
30	102.4	23.6	15.7	11.8	9.4	7.9	6.7	5.9	5.2	4.7	4.3	3.9	3.6
50	170.6	39.3	26.2	19.7	15.7	13.1	11.2	9.8	8.7	7.9	7.1	6.6	6.0
70	238.8	55.0	36.7	27.5	22.0	18.3	15.7	13.8	12.2	11.0	10.0	9.2	8.5
90	307.1		47.2	35.4	28.3	23.6	20.2	17.7	15.7	14.2	12.9	11.8	10.9
110	375.3		57.7	43.2	34.6	28.8	24.7	21.6	19.2	17.3	15.7	14.4	13.3
130	443.6			51.1	40.9	34.1	29.2	25.6	22.7	20.4	18.6	17.0	15.7
150	511.8			59.0	47.2	39.3	33.7	29.5	26.2	23.6	21.4	19.7	18.1
170	580.1				53.5	44.6	38.2	33.4	29.7	26.7	24.3	22.3	20.6
190	648.3				59.8	49.8	42.7	37.3	33.2	29.9	27.2	24.9	23.0

Notes:

1. Maximum permitted air temperature rise; 20-50 tons (cULus - 50°F), 60 - 75 tons (cULus - 43°F).
2. Air temperature rise = kW x 3413 ÷ (scfm x 1.085)
3. All heaters on units provide 3 increments of capacity.
4. 200 and 230 volt electric heat rooftops require dual power supplies to the control box. All other rooftops have single power connections. See Electrical Data Section for electrical sizing information.

Performance Data

Table 52. Electric Heat kW Ranges

Nominal Tons	Nominal Voltage			
	200	230	460	575
20	30-90	30-110	30-110	30-110
25	30-90	30-110	30-130	30-130
30	30-110	30-110	30-150	30-150
40	50-110	50-110	50-170	50-170
50-55	70-110	70-110	70-190	70-190
60	90-110	90-110	90-190	90-190
70	90-110	90-110	90-190	90-190
75	90-110	90-110	90-190	90-190
90	NA	NA	190	190
105	NA	NA	190	190
115	NA	NA	190	190
130	NA	NA	190	190

Table 51. Electric Heat Air Temperature Rise – 90 to 130 Ton

kW Input	Total MBh	CFM					
		24000	27000	30000	33000	36000	40000
190	648.3	24.9	22.1	19.9	18.1	16.5	15.3

Notes:

1. Air Temperature = kW x 3413 ÷ (scfm x 1.085)
2. Only available in 460/60/3 and 575/60/3 voltages.

Table 53. Hot Water Heating Capacities (Q/ITD)^(a)

20, 25, 30 Nominal Tons ^(b)								
Hot Water Module	Gpm	Water PD (Ft)	Unit Standard Air Volume (CFM)					
			4000	6000	8000	10000	12000	14000
Low	10	0.54	1.65	1.99	2.21	2.37	2.48	2.56
High	20	0.91	2.23	2.78	3.16	3.44	3.67	3.85
Low	20	0.91	1.88	2.35	2.69	2.94	3.12	3.27
High	30	1.49	2.36	3.00	3.46	3.81	4.09	4.31
Low	30	1.49	1.97	2.51	2.90	3.19	3.42	3.60
High	40	2.25	2.43	3.12	3.63	4.02	4.34	4.60
Low	40	2.25	2.02	2.60	3.02	3.34	3.60	3.79
High	50	3.2	2.48	3.20	3.74	4.17	4.51	4.80
Low	60	4.31	2.08	2.69	3.16	3.51	3.79	4.02
High	70	5.65	2.54	3.30	3.88	4.35	4.73	5.04

Table 53. Hot Water Heating Capacities (Q/ITD)^(a) (continued)

40, 50-55 Nominal Tons ^(b)								
Hot Water Module	Gpm	Water PD (Ft)	Unit Standard Air Volume (CFM)					
			8000	11000	14000	17000	20000	23000
Low	20	0.70	3.00	3.44	3.75	3.98	4.14	4.29
High	30	1.05	3.85	4.46	4.91	5.26	5.54	5.76
Low	40	1.51	3.40	4.00	4.43	4.76	5.02	5.21
High	50	2.10	4.20	4.95	5.52	5.97	6.34	6.64
Low	60	2.78	3.56	4.23	4.73	5.11	5.40	5.63
High	75	4.04	4.39	5.24	5.89	6.41	6.85	7.21
Low	80	4.50	3.65	4.36	4.89	5.31	5.63	5.88
High	90	5.54	4.46	5.34	6.03	6.58	7.04	7.42
Low	100	6.66	3.71	4.44	5.00	5.43	5.77	6.04
High	125	9.99	4.56	5.50	6.23	6.83	7.33	7.75
60, 70, 75 Nominal Tons ^(b)								
Hot Water Module	Gpm	Water PD (Ft)	Unit Standard Air Volume (CFM)					
			12000	16000	20000	24000	28000	31500
Low	25	0.98	4.28	4.82	5.20	5.48	5.69	5.83
High	30	1.22	5.24	5.91	6.40	6.77	7.06	7.27
Low	50	2.48	4.90	5.63	6.18	6.60	6.92	7.15
High	60	3.33	6.01	6.94	7.66	8.22	8.69	9.03
Low	75	4.83	5.14	5.97	6.60	7.09	7.46	7.73
High	90	6.65	6.32	7.38	8.20	8.87	9.42	9.83
Low	100	8.0	5.28	6.16	6.84	7.36	7.78	8.07
High	120	11.15	6.49	7.62	8.51	9.23	9.84	10.30
Low	125	11.99	5.37	6.29	6.99	7.54	7.98	8.29
High	150	16.8	6.60	7.77	8.71	9.47	10.11	10.60
90, 105, 115, 130 Nominal Tons								
Hot Water Module	Gpm	Water PD (Ft)	Unit Standard Air Volume (CFM)					
			27000	30000	33000	36000	39000	42000
Low	30	0.77	6.68	6.87	7.04	7.18	7.30	7.41
High	40	1.02	8.51	8.80	9.04	9.26	9.45	9.62
Low	60	1.69	8.07	8.38	8.64	8.87	9.07	9.25
High	80	2.6	10.21	10.64	11.03	11.38	11.69	11.98
Low	100	3.71	8.82	9.19	9.52	9.80	10.05	10.26
High	120	5.07	10.95	11.46	11.92	12.33	12.71	13.05
Low	140	6.59	9.19	9.60	9.96	10.27	10.55	10.79
High	160	8.37	11.37	11.93	12.43	12.88	13.30	13.67
Low	175	9.8	9.39	9.82	10.20	10.53	10.82	11.07
High	200	12.52	11.64	12.23	12.76	13.24	13.68	14.08

(a) Capacities expressed as MBh per initial temperature difference (ITD) between the entering air temperature to the hot water coil and the entering water temperature. Ethylene glycol or other capacities can be determined from the Trane heating coil computer program. Capacity and pressure drop of ethylene glycol vary greatly with temperature and concentration.

(b) Model number sizes are listed as air-cooled/evaporative condensing

Supply Fan Performance

Figure 9. Supply fan performance with or without variable frequency drive - 20 and 25 ton air-cooled - forward curved

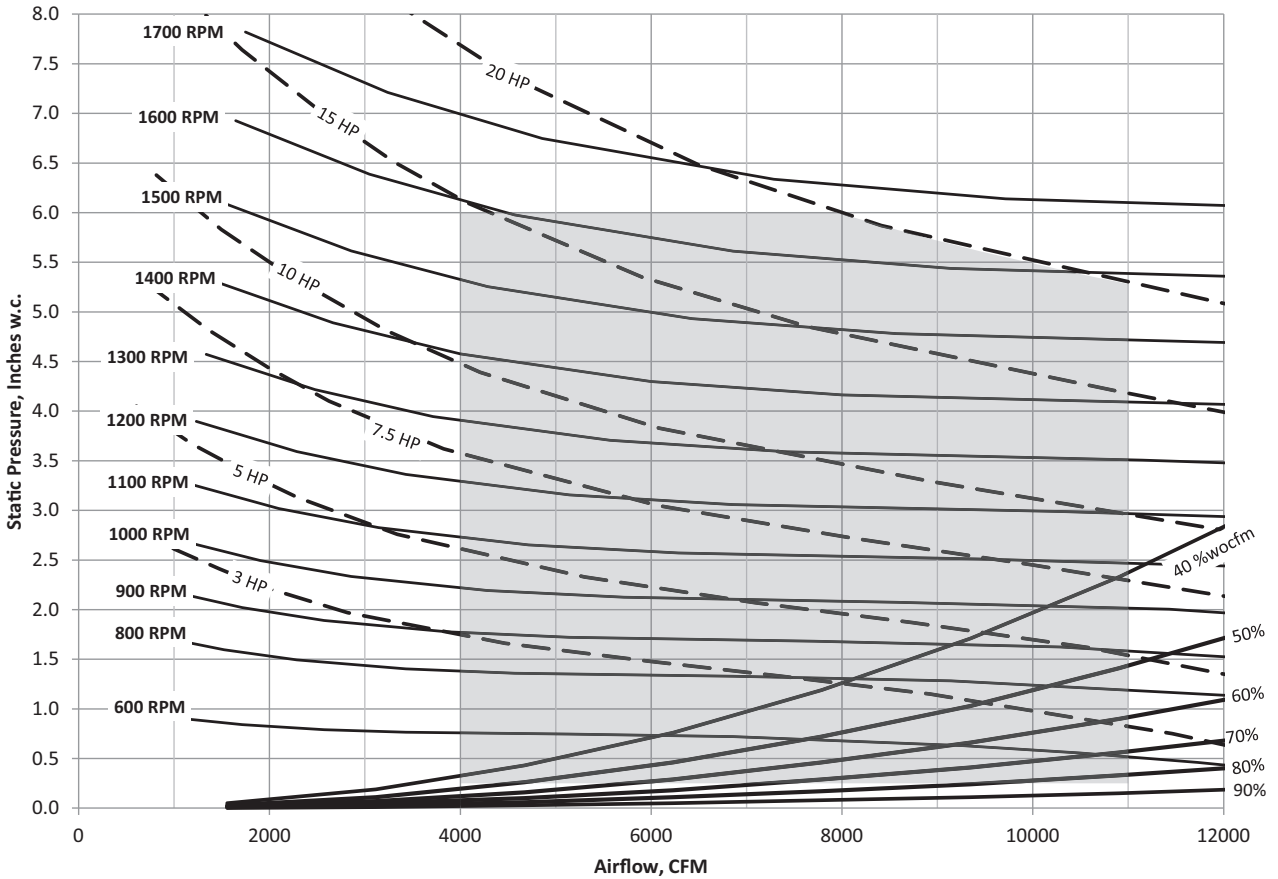

Important: Maximum static pressure leaving the rooftop is 4.0" H₂O positive. The static pressure drops from the supply fan to the space cannot exceed 4.0" H₂O.

Notes:

1. Fan performance for 20 and 25 ton rooftops is identical. Contact your local Trane representative for information on oversized motors.
2. Shaded areas represent selectable area. Contact your local Trane representative for more information.
3. Supply fan performance table includes internal resistance of rooftop. For total static pressure determination, system external static must be added to appropriate component static pressure drops (evaporator coil, filters, optional economizer, optional exhaust fan, optional heating system, optional cooling only extended casing, optional roof curb).
4. Maximum Cfm (for cULus approval) as follows: 20 ton - 9,000 Cfm, 25 ton - 11,000 Cfm.
5. Minimum motor horsepower is 3 hp.
6. Maximum motor horsepower is 20 hp.
7. Maximum fan RPM is 1750.

Figure 10. Supply fan performance with variable frequency drive - 20 and 25 ton air-cooled - direct drive plenum, 80% width

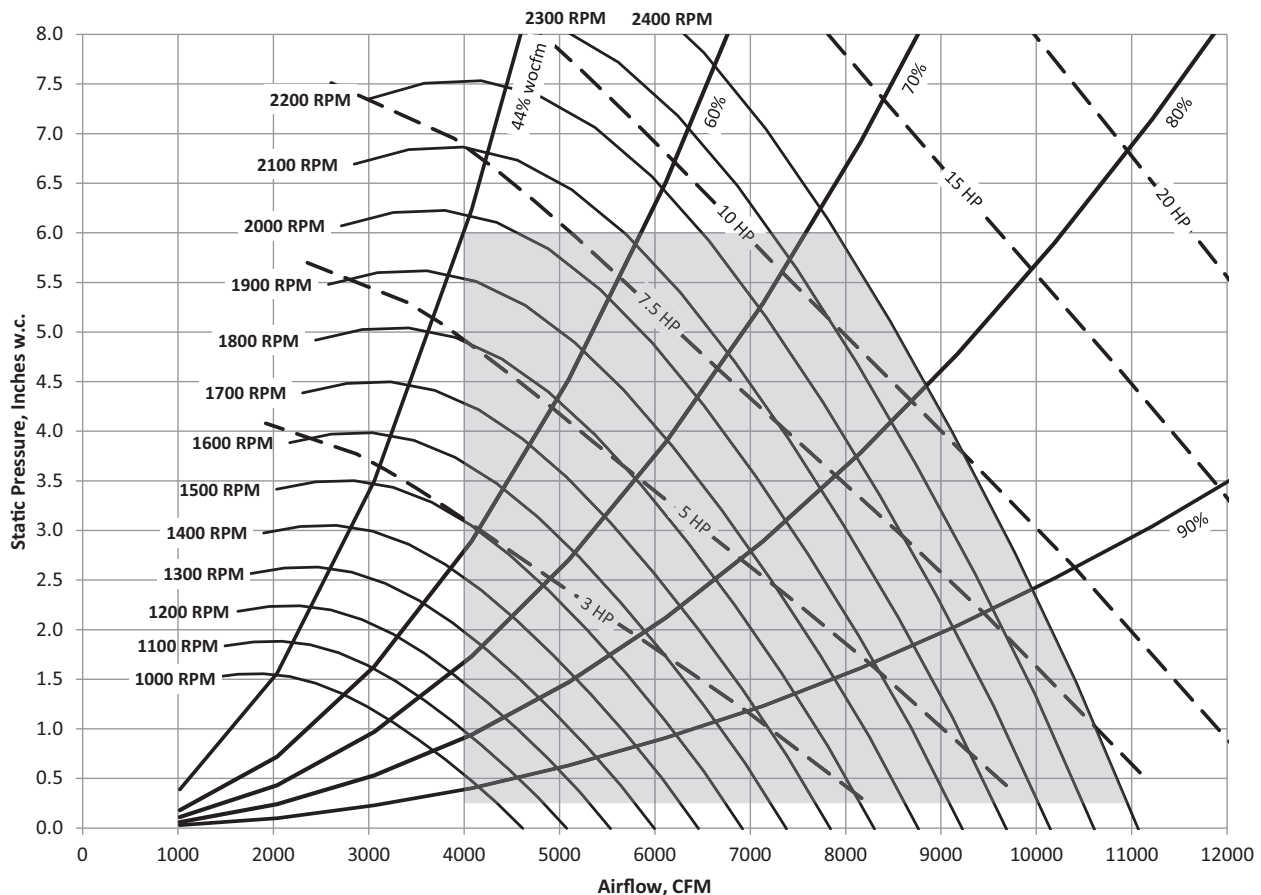

Important: Maximum static pressure leaving the rooftop is 4.0" H₂O positive. The static pressure drops from the supply fan to the space cannot exceed 4.0" H₂O.

1. Shaded areas represent selectable area. Contact your local Trane representative for more information.
2. Supply fan performance curve includes internal resistance of rooftop. For total static pressure determination, system external static must be added to appropriate component static pressure drops (evaporator coil, filters, optional economizer, optional exhaust fan, optional heating system, optional cooling only extended casing, optional roof curb).
3. Maximum Cfm (for cULus approval) as follows: 20 ton - 9,000 Cfm, 25 ton - 11,000 Cfm.
4. Minimum motor horsepower is 3 hp.
5. Maximum motor horsepower is 20 hp.
6. Maximum fan RPM is 2400.

Performance Data

Figure 11. Supply fan performance with variable frequency drive - 20 and 25 ton air-cooled - direct drive plenum, 120% width

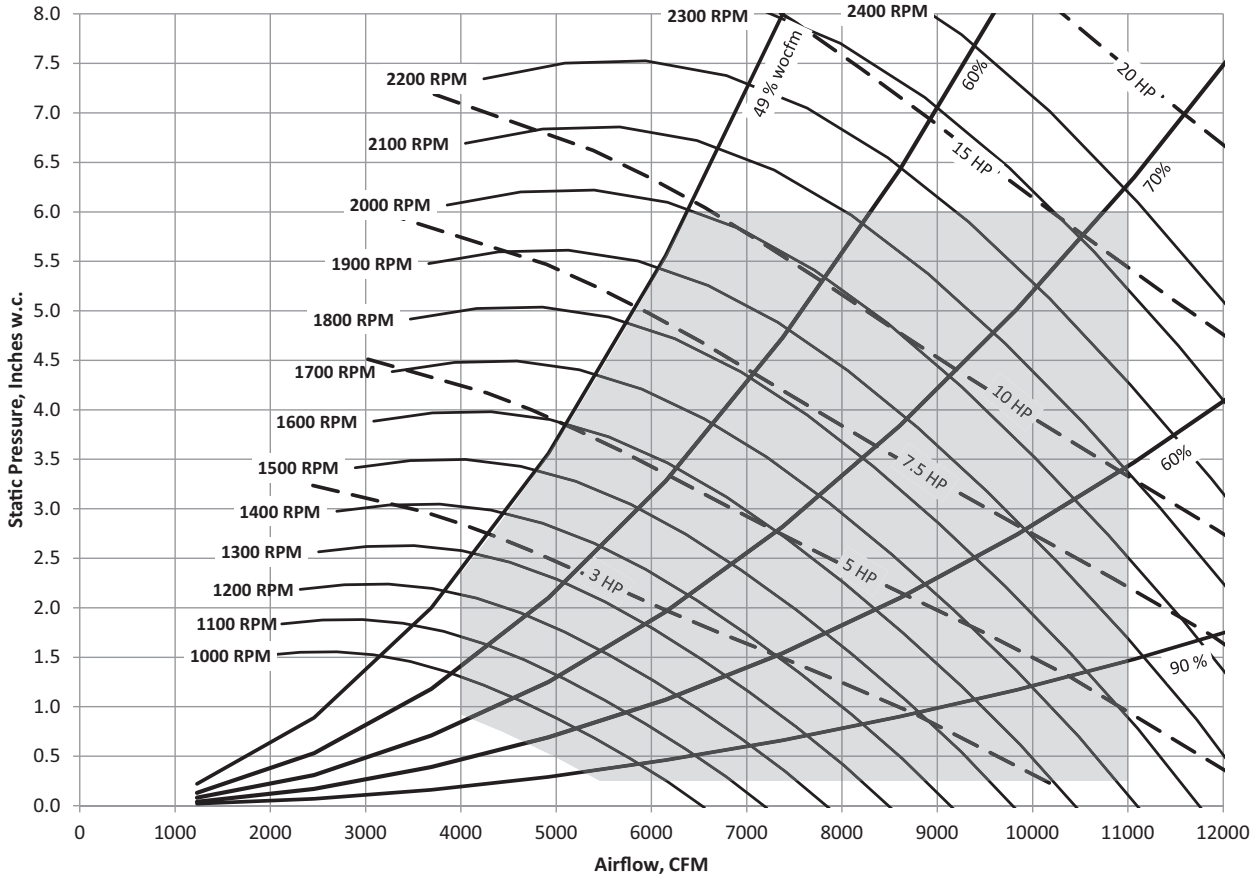

Important: Maximum static pressure leaving the rooftop is 4.0" H₂O positive. The static pressure drops from the supply fan to the space cannot exceed 4.0" H₂O.

1. Shaded areas represent selectable area. Contact your local Trane representative for more information.
2. Supply fan performance curve includes internal resistance of rooftop. For total static pressure determination, system external static must be added to appropriate component static pressure drops (evaporator coil, filters, optional economizer, optional exhaust fan, optional heating system, optional cooling only extended casing, optional roof curb).
3. Maximum Cfm (for cULus approval) as follows: 20 ton - 9,000 Cfm, 25 ton - 11,000 Cfm.
4. Minimum motor horsepower is 3 hp.
5. Maximum motor horsepower is 20 hp.
6. Maximum fan RPM is 2400.

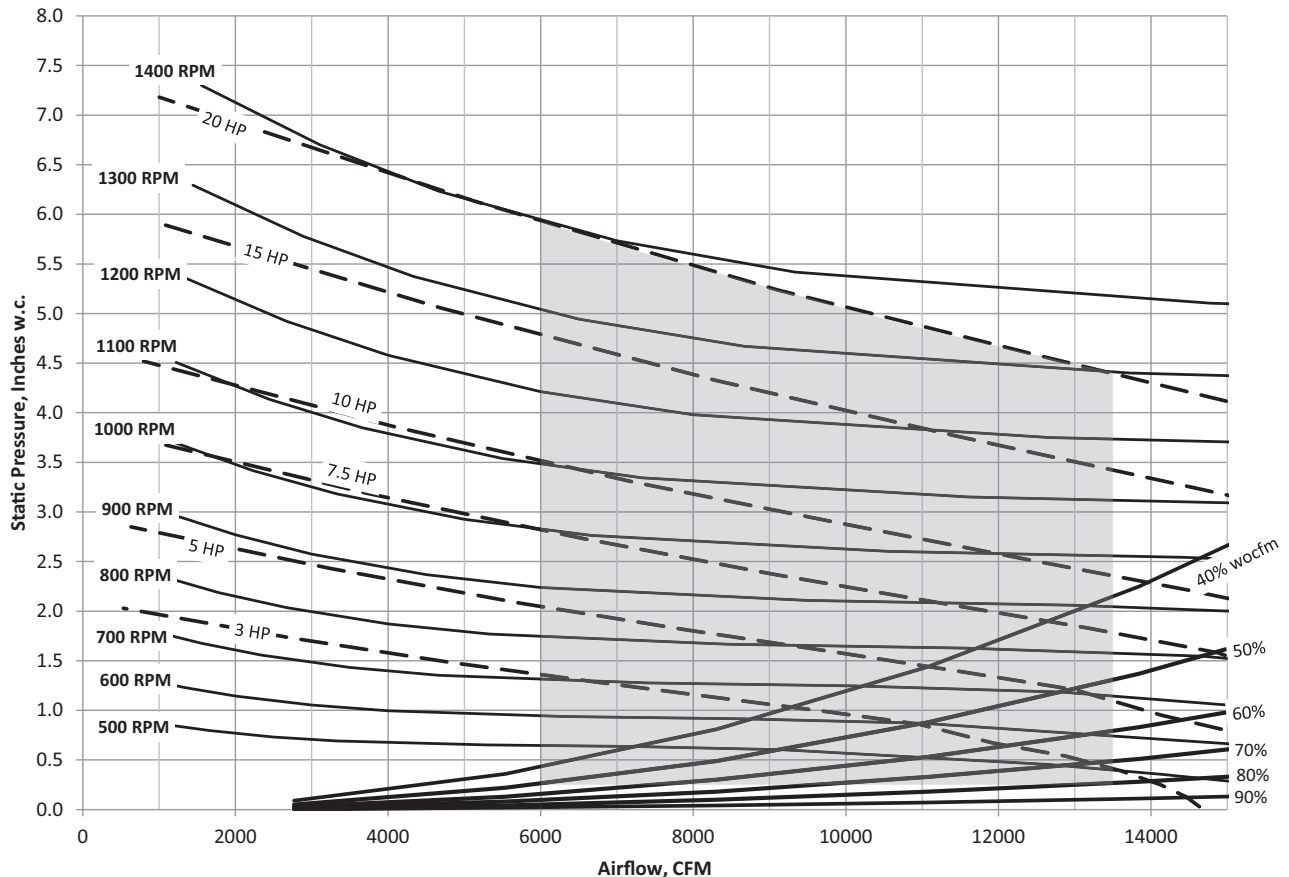
Figure 12. Supply fan performance with or without variable frequency drive — 30 ton air-cooled - forward curved

Important: Maximum static pressure leaving the rooftop is 4.0" H₂O positive. The static pressure drops from the supply fan to the space cannot exceed 4.0" H₂O.

Notes:

1. Shaded areas represent selectable area. Contact your local Trane representative for more information.
2. Supply fan performance table includes internal resistance of rooftop. For total static pressure determination, system external static must be added to appropriate component static pressure drops (evaporator coil, filters, optional economizer, optional exhaust fan, optional heating system, optional cooling only extended casing, optional roof curb).
3. Minimum motor horsepower is 5 hp, maximum motor horsepower is 20 hp. Maximum fan RPM is 1450.
4. Max Cfm (for cULus approval) as follows: 30 ton-13,500 Cfm.

Performance Data

Figure 13. Supply fan performance with variable frequency drive — 30 ton air-cooled - direct drive plenum, 80% width

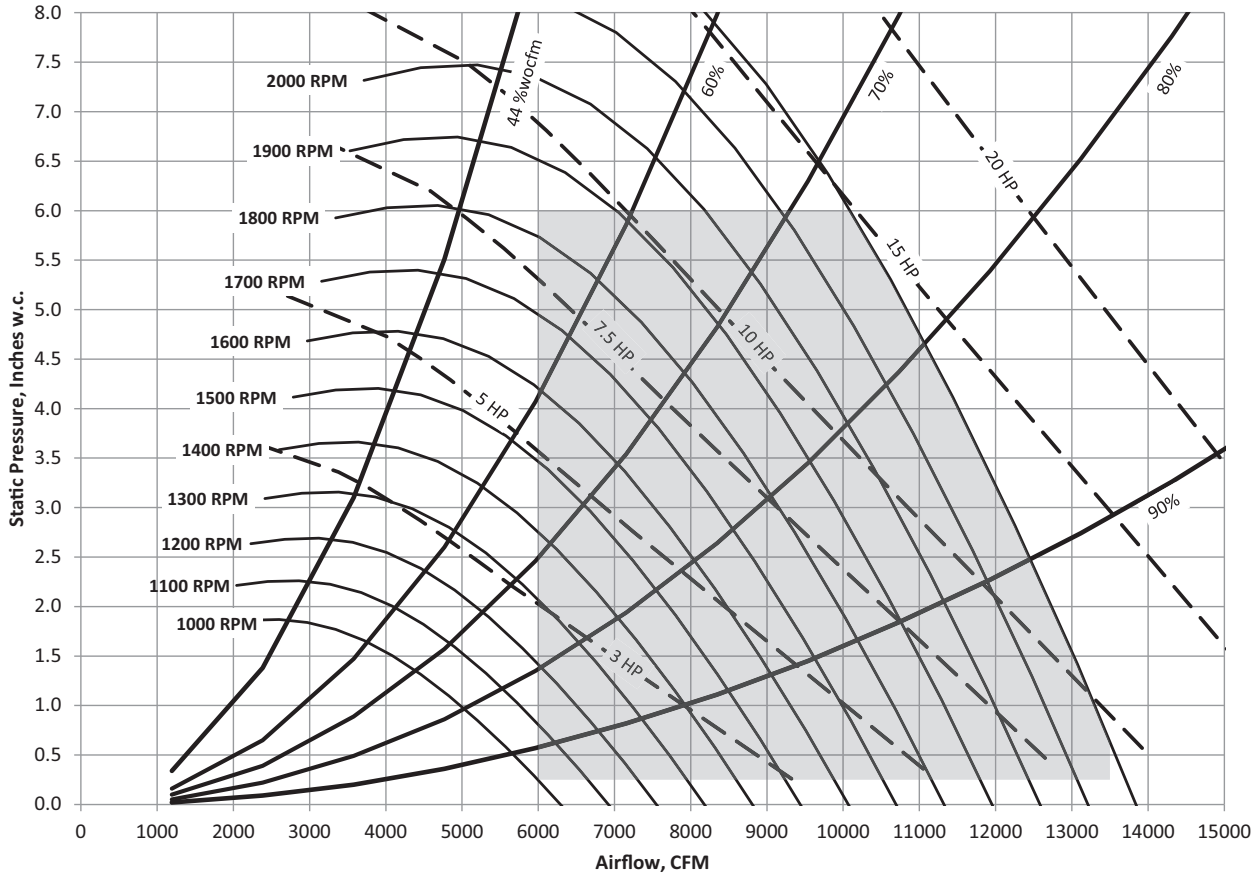

Important: Maximum static pressure leaving the rooftop is 4.0" H₂O positive. The static pressure drops from the supply fan to the space cannot exceed 4.0" H₂O.

1. Shaded areas represent selectable area. Contact your local Trane representative for more information.
2. Supply fan performance curve includes internal resistance of rooftop. For total static pressure determination, system external static must be added to appropriate component static pressure drops (evaporator coil, filters, optional economizer, optional exhaust fan, optional heating system, optional cooling only extended casing, optional roof curb).
3. Maximum Cfm (for cULus approval) as follows: 30 ton - 13,500 Cfm.
4. Minimum motor horsepower is 3 hp.
5. Maximum motor horsepower is 20 hp.
6. Maximum fan RPM is 2200.

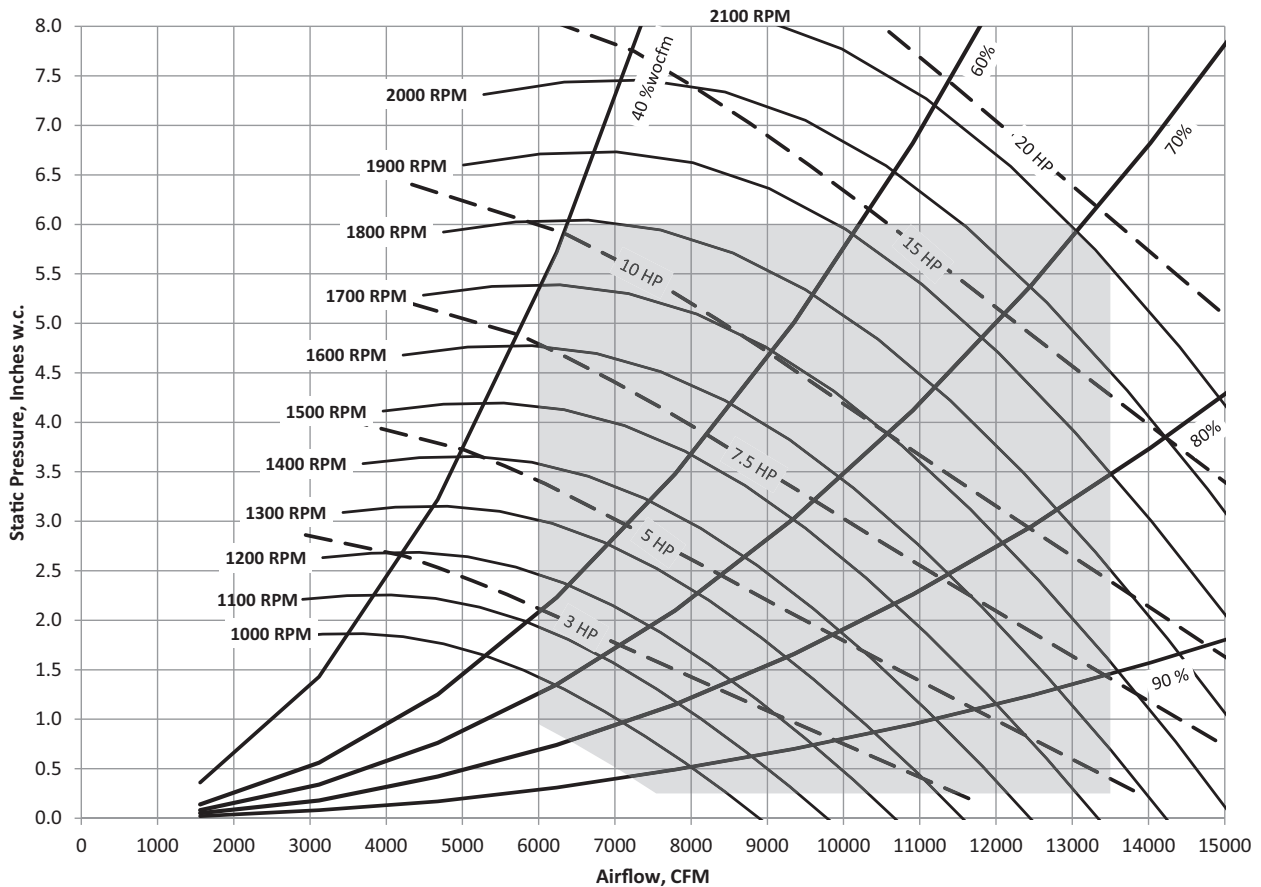
Figure 14. Supply fan performance with variable frequency drive — 30 ton air-cooled- direct drive plenum, 120% width

Important: Maximum static pressure leaving the rooftop is 4.0" H₂O positive. The static pressure drops from the supply fan to the space cannot exceed 4.0" H₂O.

1. Shaded areas represent selectable area. Contact your local Trane representative for more information.
2. Supply fan performance curve includes internal resistance of rooftop. For total static pressure determination, system external static must be added to appropriate component static pressure drops (evaporator coil, filters, optional economizer, optional exhaust fan, optional heating system, optional cooling only extended casing, optional roof curb).
3. Maximum Cfm (for cULus approval) as follows: 30ton - 13,500 Cfm.
4. Minimum motor horsepower is 3 hp.
5. Maximum motor horsepower is 20 hp.
6. Maximum fan RPM is 2100.

Performance Data

Figure 15. Supply fan performance with or without variable frequency drive - 40, 50 and 55 ton air-cooled - forward curved

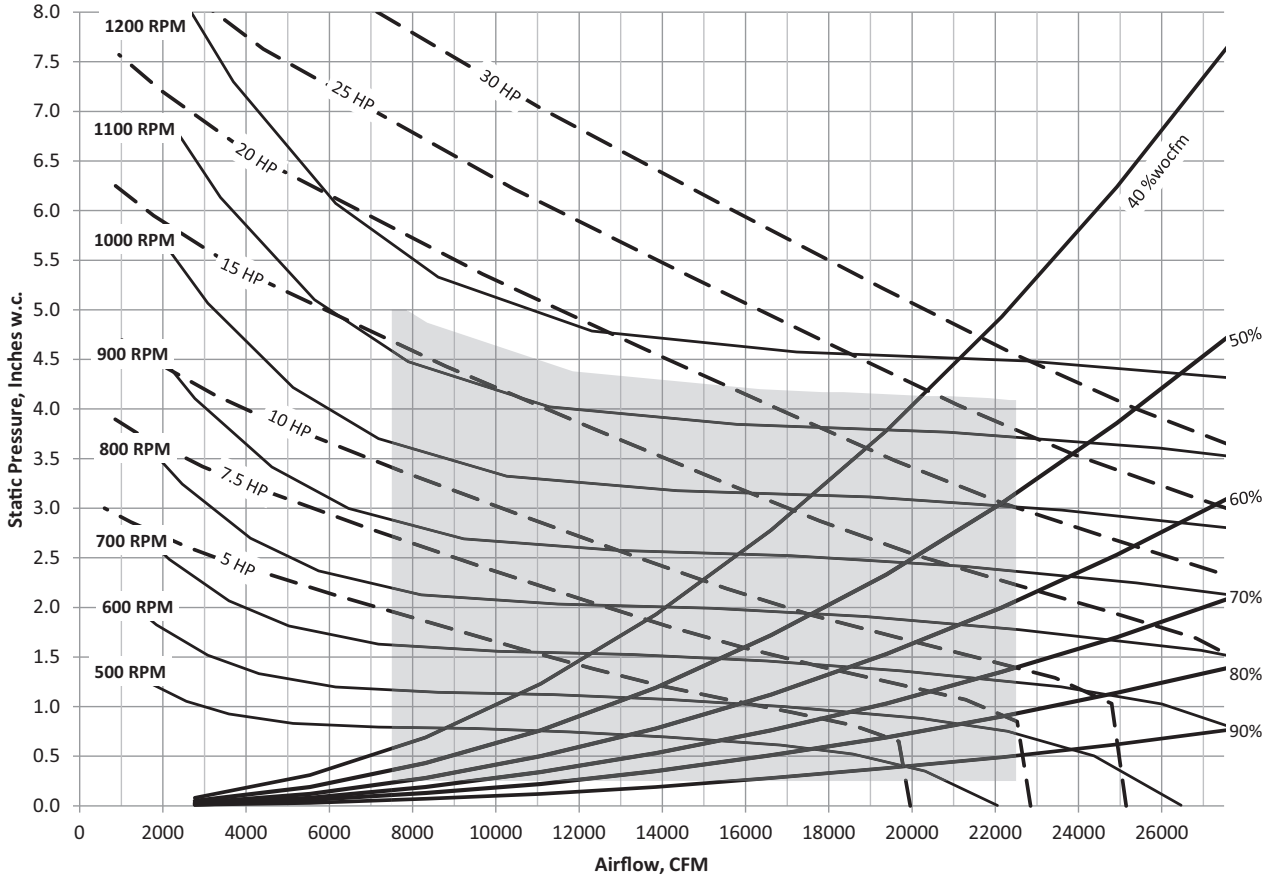

Important: Maximum static pressure leaving the rooftop is 4.0" H₂O positive. The static pressure drops from the supply fan to the space cannot exceed 4.0" H₂O.

Notes:

1. Fan performance for 40 and 50-55 ton rooftops is identical. Contact your local Trane representative for information on oversized motors.
2. Shaded areas represent selectable area. Contact your local Trane representative for more information.
3. Supply fan performance table includes internal resistance of rooftop. For total static pressure determination, system external static must be added to appropriate component static pressure drops (evaporator coil, filters, optional economizer, optional exhaust fan, optional heating system, optional cooling only extended casing, optional roof curb).
4. Maximum Cfm (for cULus approval) as follows:
 40 ton - 18,000 Cfm
 50 ton - 22,500 Cfm
5. Minimum motor horsepower is 7.5 hp
6. Maximum motor horsepower is 30 hp
7. Maximum 7.5 hp to 15 hp fan Rpm is 1,141 Rpm, maximum 20 hp to 30 hp fan Rpm is 1,170 Rpm.

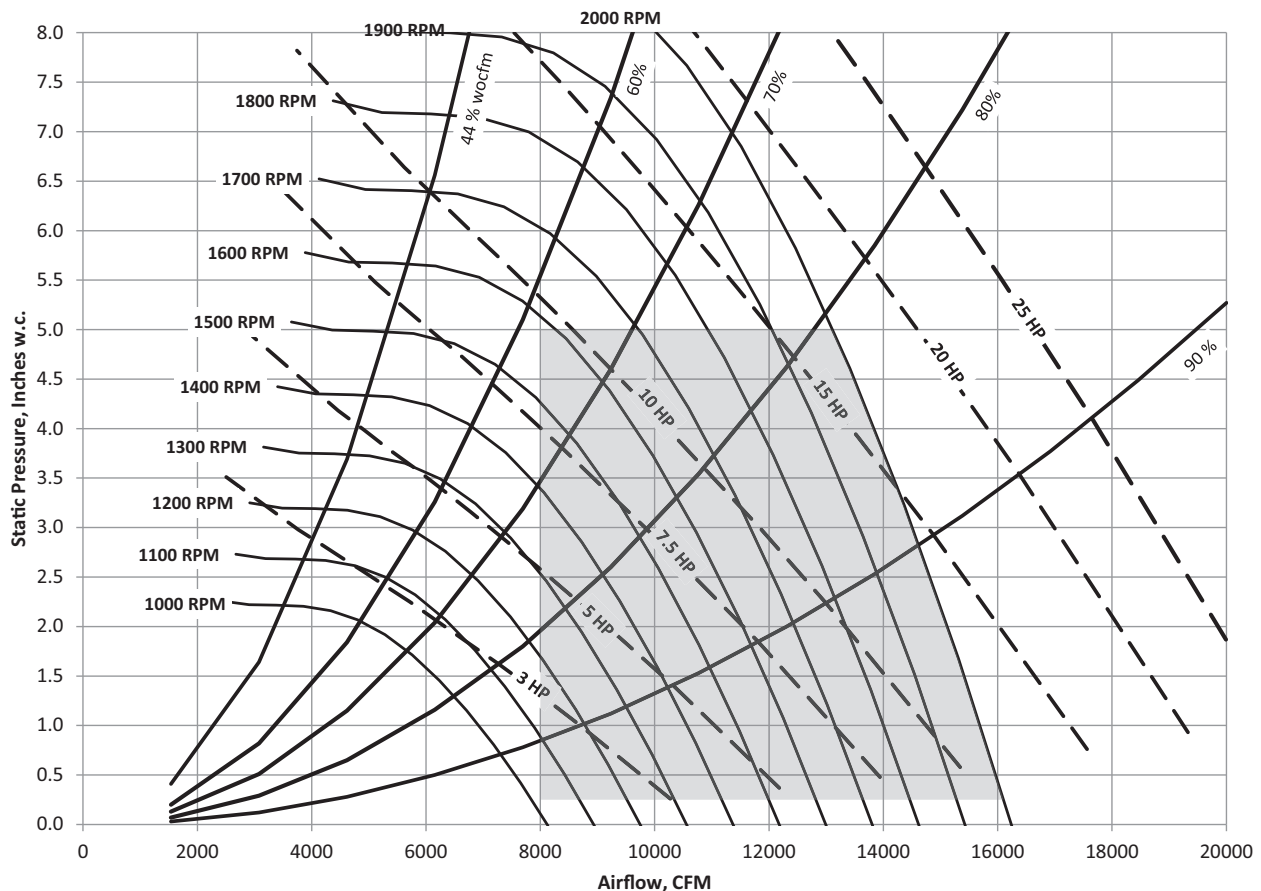
Figure 16. Supply fan performance with variable frequency drive - 40 ton air-cooled - direct drive plenum, 80% width

Important: Maximum static pressure leaving the rooftop is 4.0" H₂O positive. The static pressure drops from the supply fan to the space cannot exceed 4.0" H₂O.

Notes:

1. Shaded areas represent selectable area. Contact your local Trane representative for more information.
2. Supply fan performance curve includes internal resistance of rooftop. For total static pressure determination, system external static must be added to appropriate component static pressure drops (evaporator coil, filters, optional economizer, optional exhaust fan, optional heating system, optional cooling only extended casing, optional roof curb).
3. Maximum Cfm (for cULus approval): 18,000 Cfm.
4. Minimum motor horsepower is 3 hp.
5. Maximum motor horsepower is 25 hp.
6. Maximum fan RPM is 2,000.

Performance Data

Figure 17. Supply fan performance with variable frequency drive - 40 ton air-cooled - direct drive plenum, 120% width

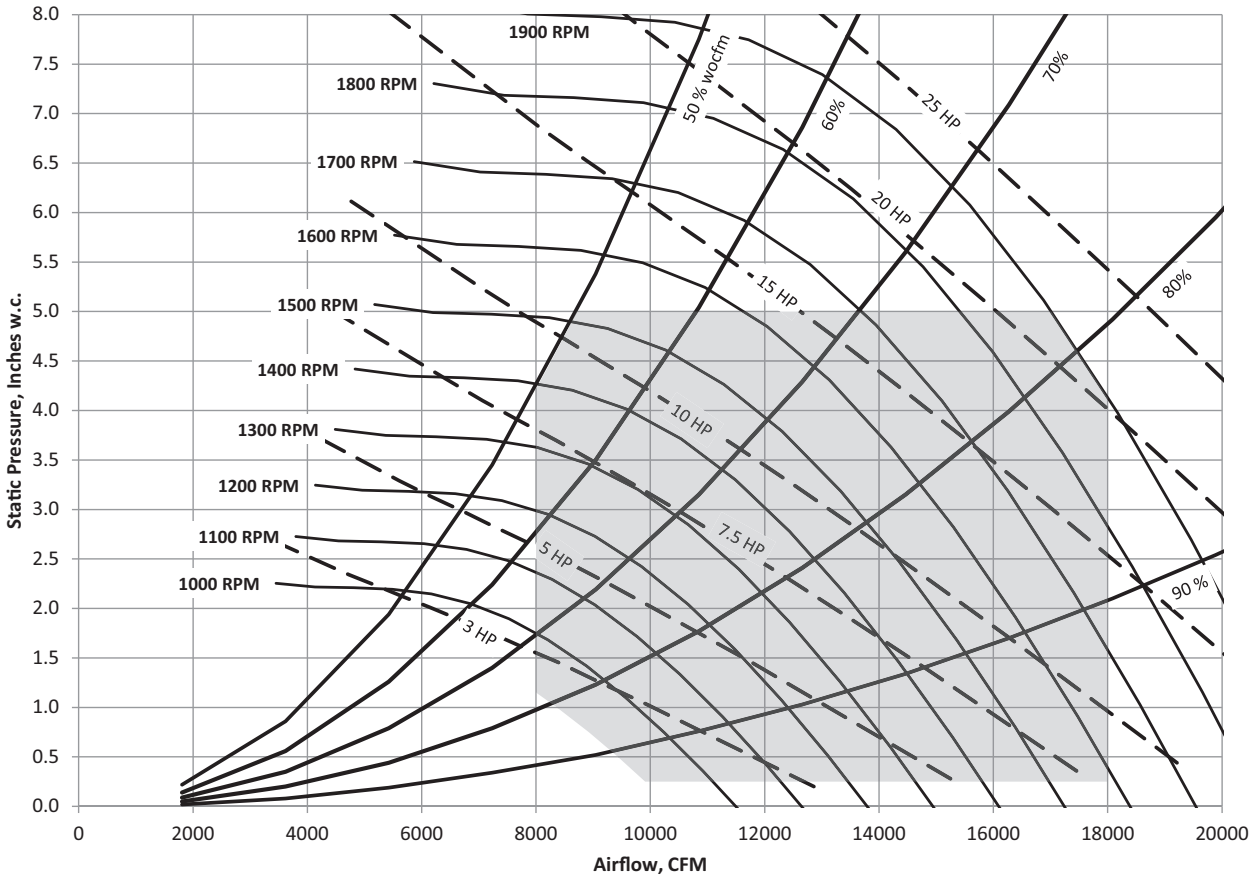

Important: Maximum static pressure leaving the rooftop is 4.0" H₂O positive. The static pressure drops from the supply fan to the space cannot exceed 4.0" H₂O.

1. Shaded areas represent selectable area. Contact your local Trane representative for more
2. Supply fan performance curve includes internal resistance of rooftop. For total static pressure determination, system external static must be added to appropriate component static pressure drops (evaporator coil, filters, optional economizer, optional exhaust fan, optional heating system, optional cooling only extended casing, optional roof curb).
3. Maximum Cfm (for cULus approval): 18,000 Cfm.
4. Minimum motor horsepower is 3 hp.
5. Maximum motor horsepower is 25 hp.
6. Maximum fan RPM is 1,900.

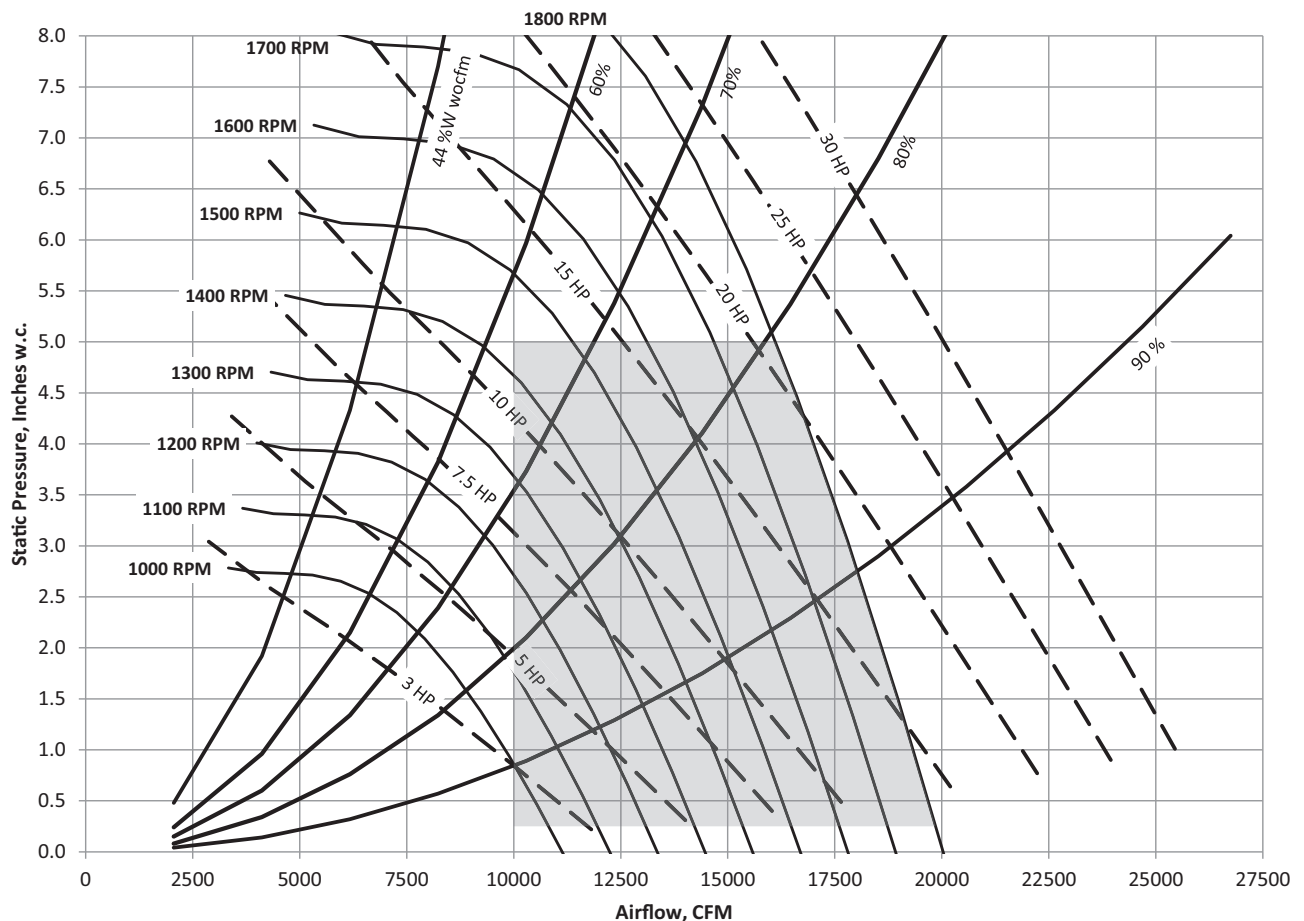
Figure 18. Supply fan performance with variable frequency drive - 50, 55 ton air-cooled- direct drive plenum, 80% width

Important: Maximum static pressure leaving the rooftop is 4.0" H₂O positive. The static pressure drops from the supply fan to the space cannot exceed 4.0" H₂O.

1. Shaded areas represent selectable area. Contact your local Trane representative for more information.
2. Supply fan performance curve includes internal resistance of rooftop. For total static pressure determination, system external static must be added to appropriate component static pressure drops (evaporator coil, filters, optional economizer, optional exhaust fan, optional heating system, optional cooling only extended casing, optional roof curb).
3. Maximum Cfm (for cULus approval) is as follows: 22,500 Cfm
4. Minimum motor horsepower is 5 hp.
5. Maximum motor horsepower is 30 hp.
6. Maximum fan RPM is 1,800.

Performance Data

Figure 19. Supply fan performance with variable frequency drive - 50, 55 ton air-cooled - direct drive plenum, 100% width

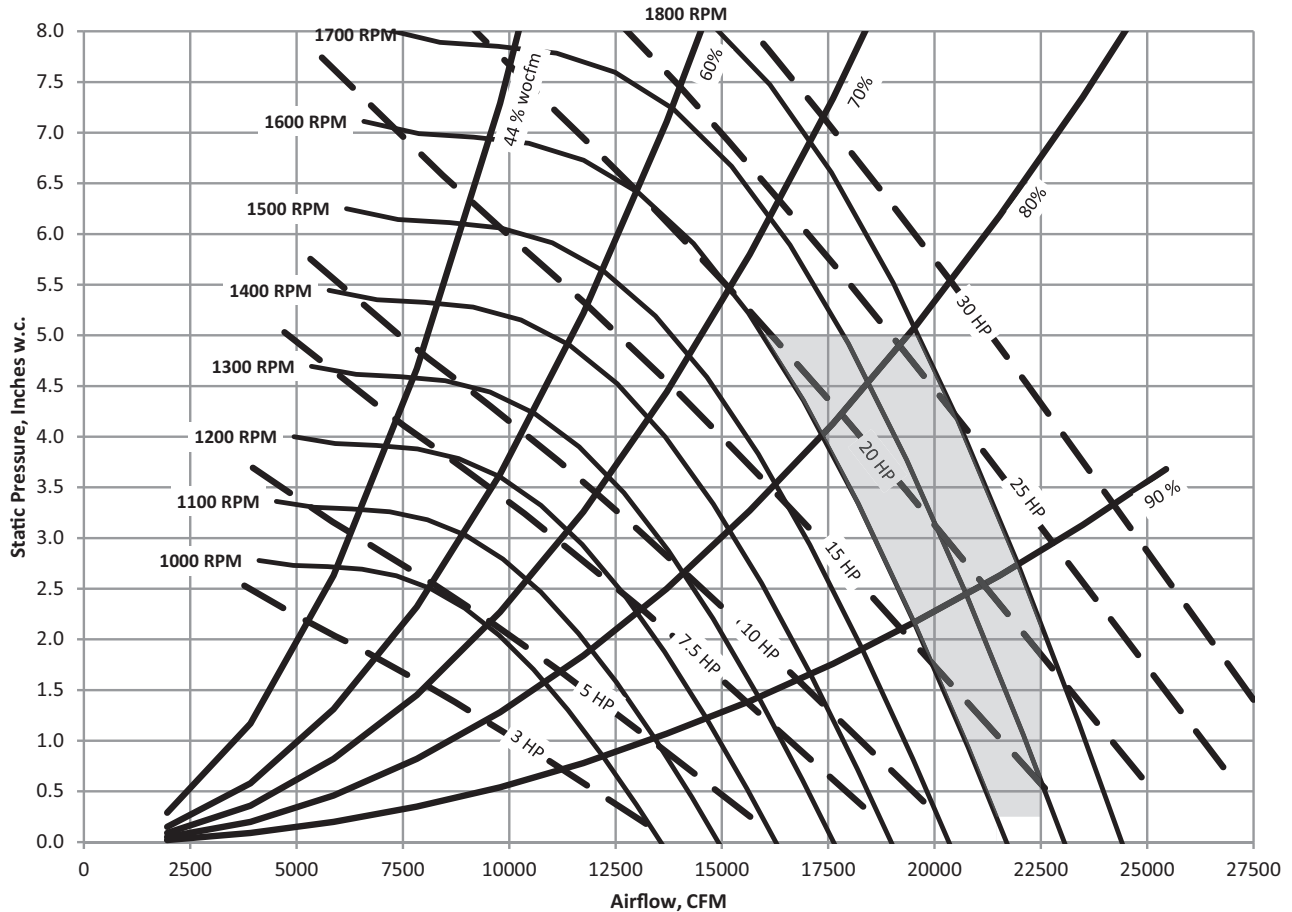

Important: Maximum static pressure leaving the rooftop is 4.0" H₂O positive. The static pressure drops from the supply fan to the space cannot exceed 4.0" H₂O.

1. Shaded areas represent selectable area. Contact your local Trane representative for more information.
2. Supply fan performance curve includes internal resistance of rooftop. For total static pressure determination, system external static must be added to appropriate component static pressure drops (evaporator coil, filters, optional economizer, optional exhaust fan, optional heating system, optional cooling only extended casing, optional roof curb).
3. Maximum Cfm (for cULus approval) is as follows: 22,500 Cfm
4. Motor horsepower is 30 hp.
5. Maximum fan RPM is 1,800.

Figure 20. Supply fan performance with variable frequency drive - 50, 55 ton air-cooled - direct drive plenum, 120% width

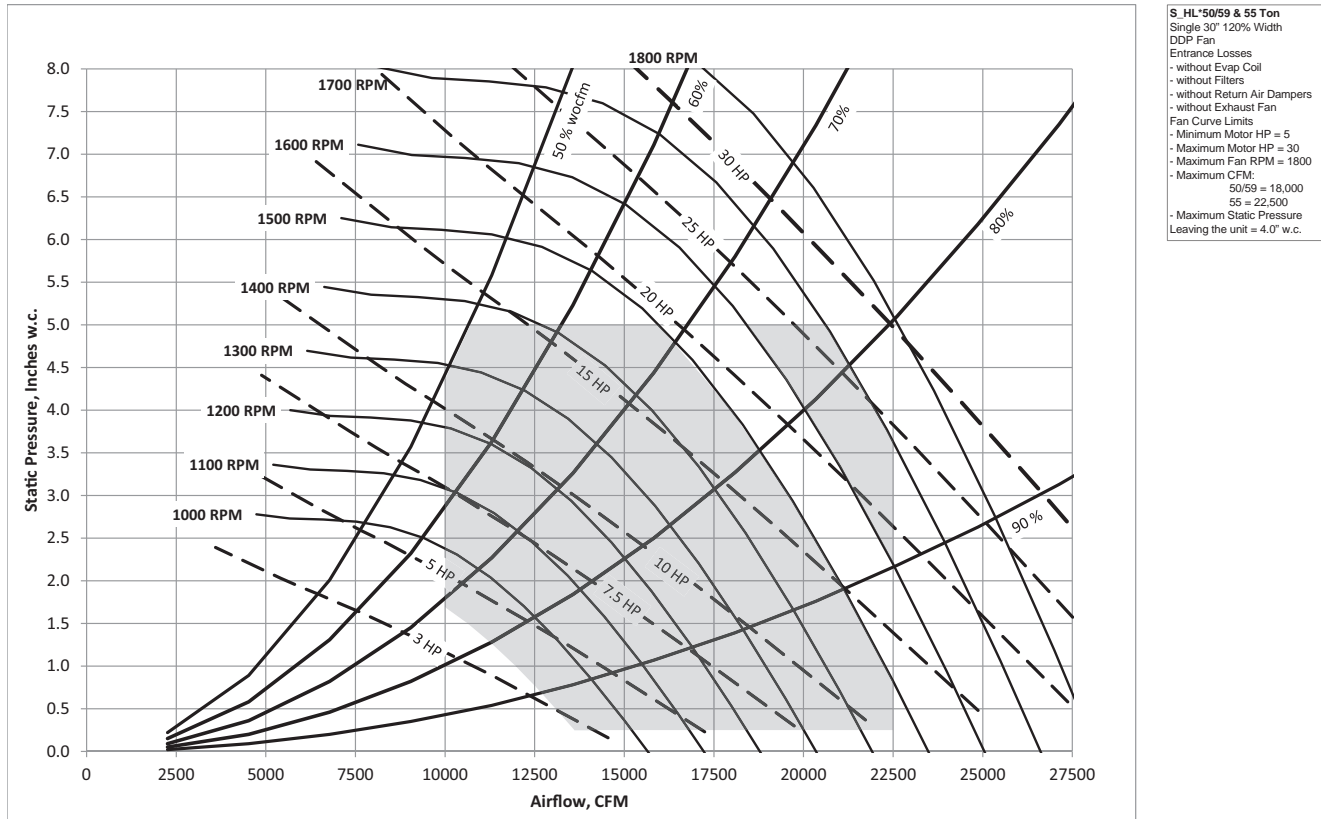

Important: Maximum static pressure leaving the rooftop is 4.0" H₂O positive. The static pressure drops from the supply fan to the space cannot exceed 4.0" H₂O.

1. Shaded areas represent selectable area. Contact your local Trane representative for more information.
2. Supply fan performance curve includes internal resistance of rooftop. For total static pressure determination, system external static must be added to appropriate component static pressure drops (evaporator coil, filters, optional economizer, optional exhaust fan, optional heating system, optional cooling only extended casing, optional roof curb).
3. Maximum Cfm (for cULus approval) is as follows: 22,500 Cfm
4. Minimum motor horsepower is 5 hp.
5. Maximum motor horsepower is 30 hp.
6. Maximum fan RPM is 1,700.

Performance Data

Figure 21. Supply fan performance with or without variable frequency drive - 60, 70 and 75 ton air-cooled - forward curved

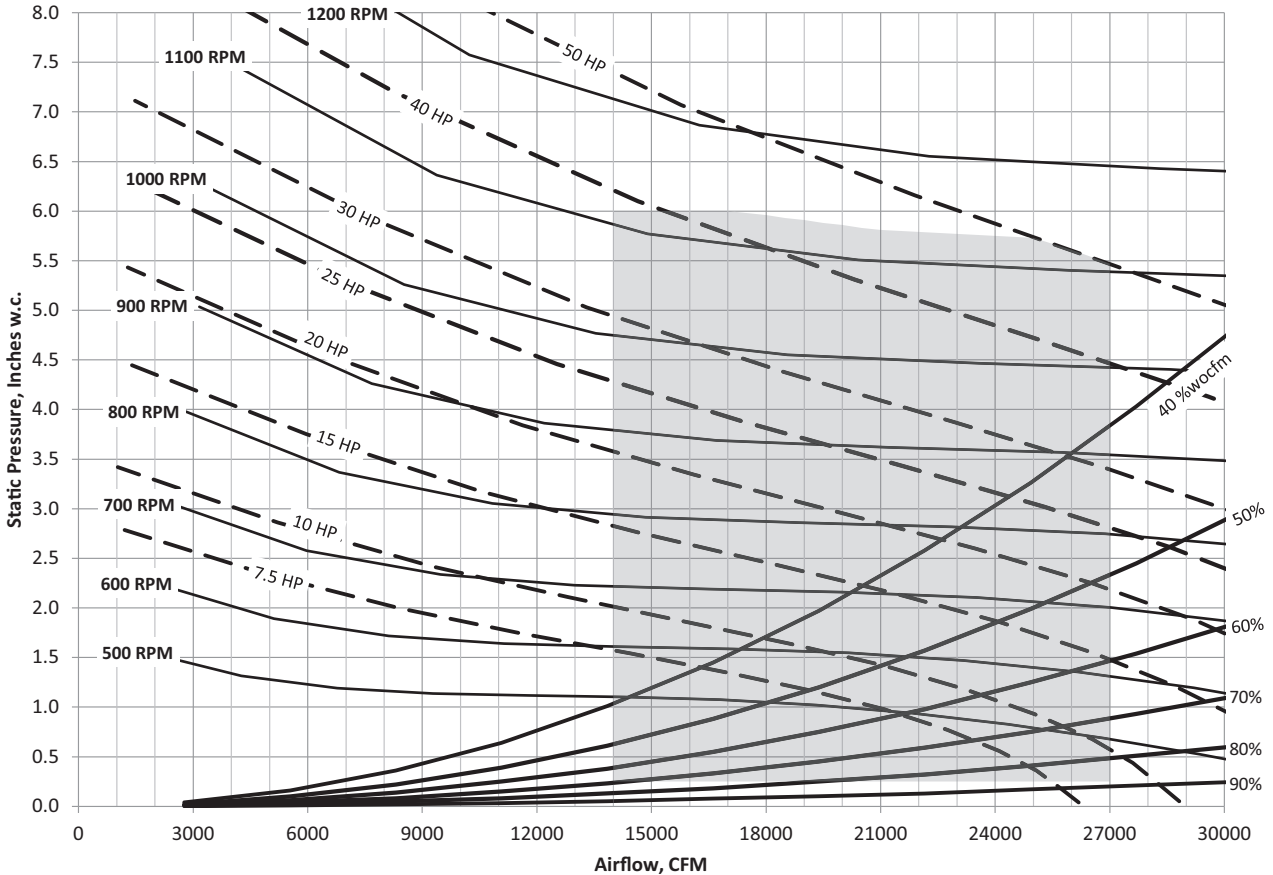

Important: Maximum static pressure leaving the rooftop is 4.0" H₂O positive. The static pressure drops from the supply fan to the space cannot exceed 4.0" H₂O.

Notes:

1. Fan performance for 60, 70 and 75 ton rooftops are identical. However, note maximum motor hp size for each size. Contact your local Trane representative for information on non-standard motors.
2. Shaded areas represent selectable area. Contact your local Trane representative for more information.
3. Supply fan performance table includes internal resistance of rooftop. For total static pressure determination, system external static must be added to appropriate component static pressure drops (evaporator coil, filters, optional economizer, optional exhaust fan, optional heating system, optional cooling only extended casing, optional roof curb).
4. Maximum Cfm (for cULus approval) as follows: 60-75 ton - 27,000 Cfm
5. Minimum motor horsepower is 10 hp.
6. Maximum motor horsepower is 50 hp.
7. Maximum fan Rpm is 1,130.
8. 40 & 50 HP motor available as standard in 460 & 575 volt only.

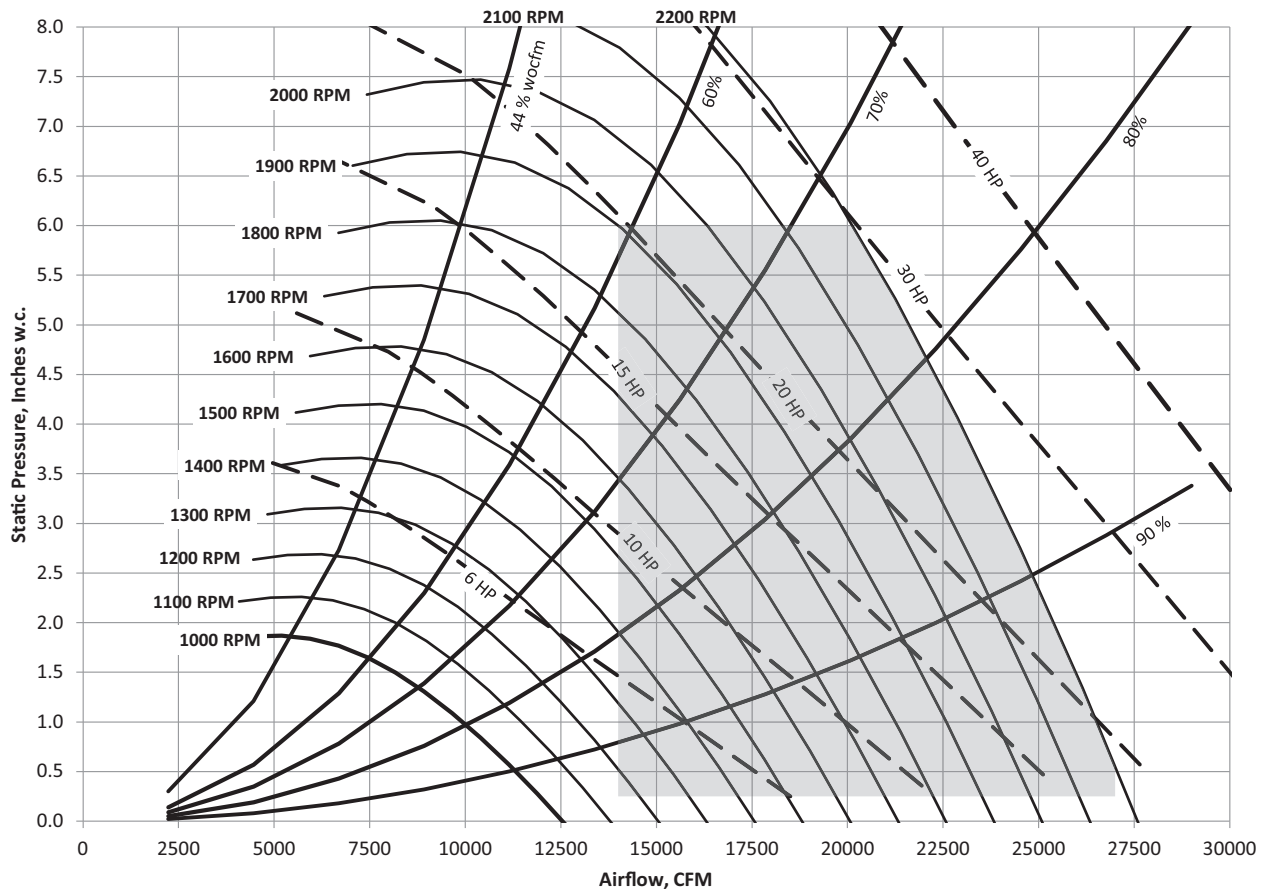
Figure 22. Supply fan performance with variable frequency drive - 60 ton air-cooled - direct drive plenum, 80% width

Important: Maximum static pressure leaving the rooftop is 4.0" H₂O positive. The static pressure drops from the supply fan to the space cannot exceed 4.0" H₂O.

1. Shaded areas represent selectable area. Contact your local Trane representative for more information.
2. Supply fan performance curve includes internal resistance of rooftop. For total static pressure determination, system external static must be added to appropriate component static pressure drops (evaporator coil, filters, optional economizer, optional exhaust fan, optional heating system, optional cooling only extended casing, optional roof curb).
3. Maximum Cfm (for cULus approval): 27,000 Cfm.
4. Minimum motor horsepower is 10 hp (2 x 5 hp motors)
5. Maximum motor horsepower is 40 hp (2 x 20 hp motors)
6. Maximum fan RPM is 2,200.

Performance Data

Figure 23. Supply fan performance with variable frequency drive - 60 ton air-cooled - direct drive plenum, 120% width

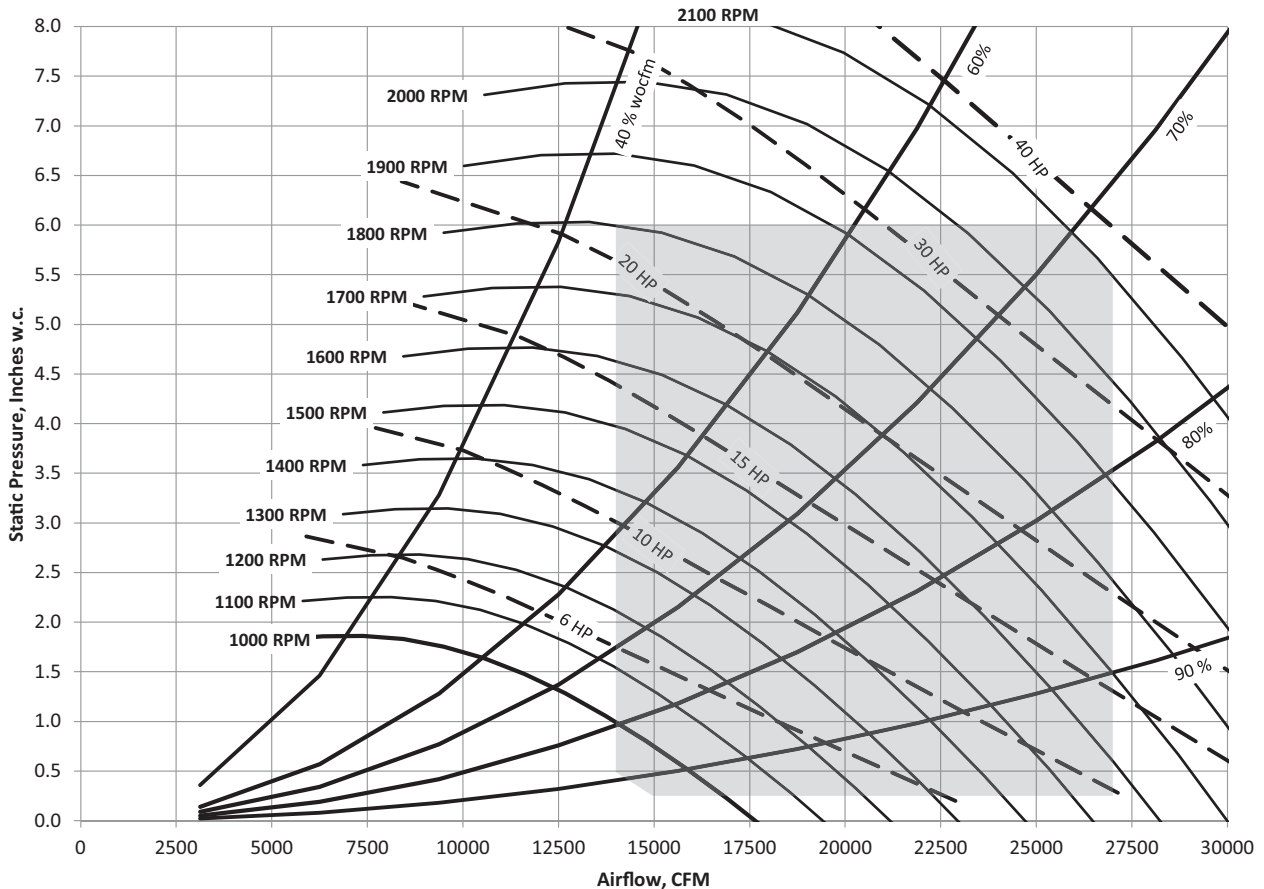

Important: Maximum static pressure leaving the rooftop is 4.0" H₂O positive. The static pressure drops from the supply fan to the space cannot exceed 4.0" H₂O.

1. Shaded areas represent selectable area. Contact your local Trane representative for more information.
2. Supply fan performance curve includes internal resistance of rooftop. For total static pressure determination, system external static must be added to appropriate component static pressure drops (evaporator coil, filters, optional economizer, optional exhaust fan, optional heating system, optional cooling only extended casing, optional roof curb).
3. Maximum Cfm (for cULus approval): 27,000 Cfm.
4. Minimum motor horsepower is 10 hp (2 x 5 hp motors)
5. Maximum motor horsepower is 40 hp (2 x 20 hp motors)
6. Maximum fan RPM is 2,100.

Figure 24. Supply fan performance with variable frequency drive - 70 and 75 ton air-cooled - direct drive plenum, 80% width

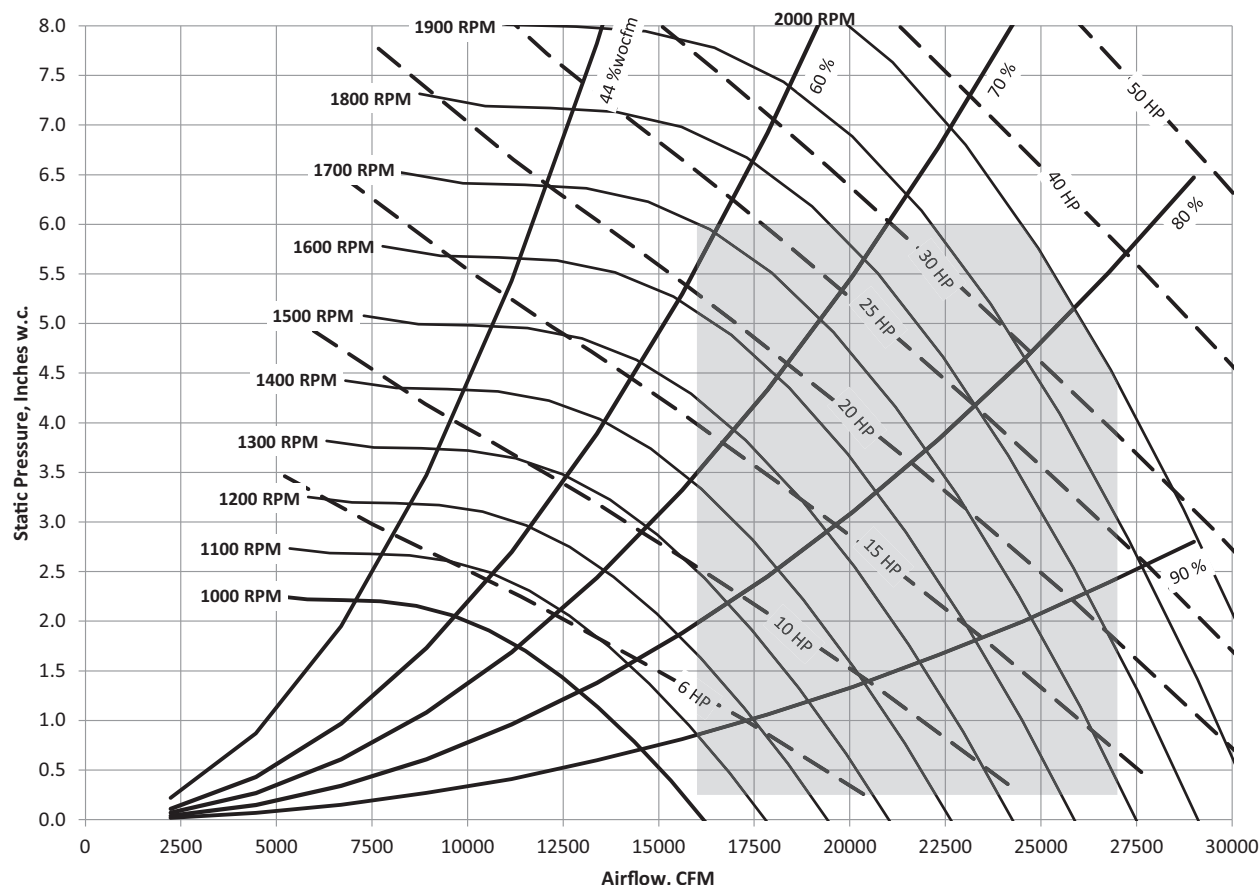

Important: Maximum static pressure leaving the rooftop is 4.0" H₂O positive. The static pressure drops from the supply fan to the space cannot exceed 4.0" H₂O.

1. Shaded areas represent selectable area. Contact your local Trane representative for more information.
2. Supply fan performance curve includes internal resistance of rooftop. For total static pressure determination, system external static must be added to appropriate component static pressure drops (evaporator coil, filters, optional economizer, optional exhaust fan, optional heating system, optional cooling only extended casing, optional roof curb).
3. Maximum Cfm (for cULus approval): 27,000 Cfm.
4. Minimum motor horsepower is 10 hp (2 x 5 hp motors)
5. Maximum motor horsepower is 50 hp (2 x 25 hp motors)
6. Maximum fan RPM is 2,000.

Performance Data

Figure 25. Supply fan performance with variable frequency drive - 70 and 75 ton air-cooled- direct drive plenum, 120% width

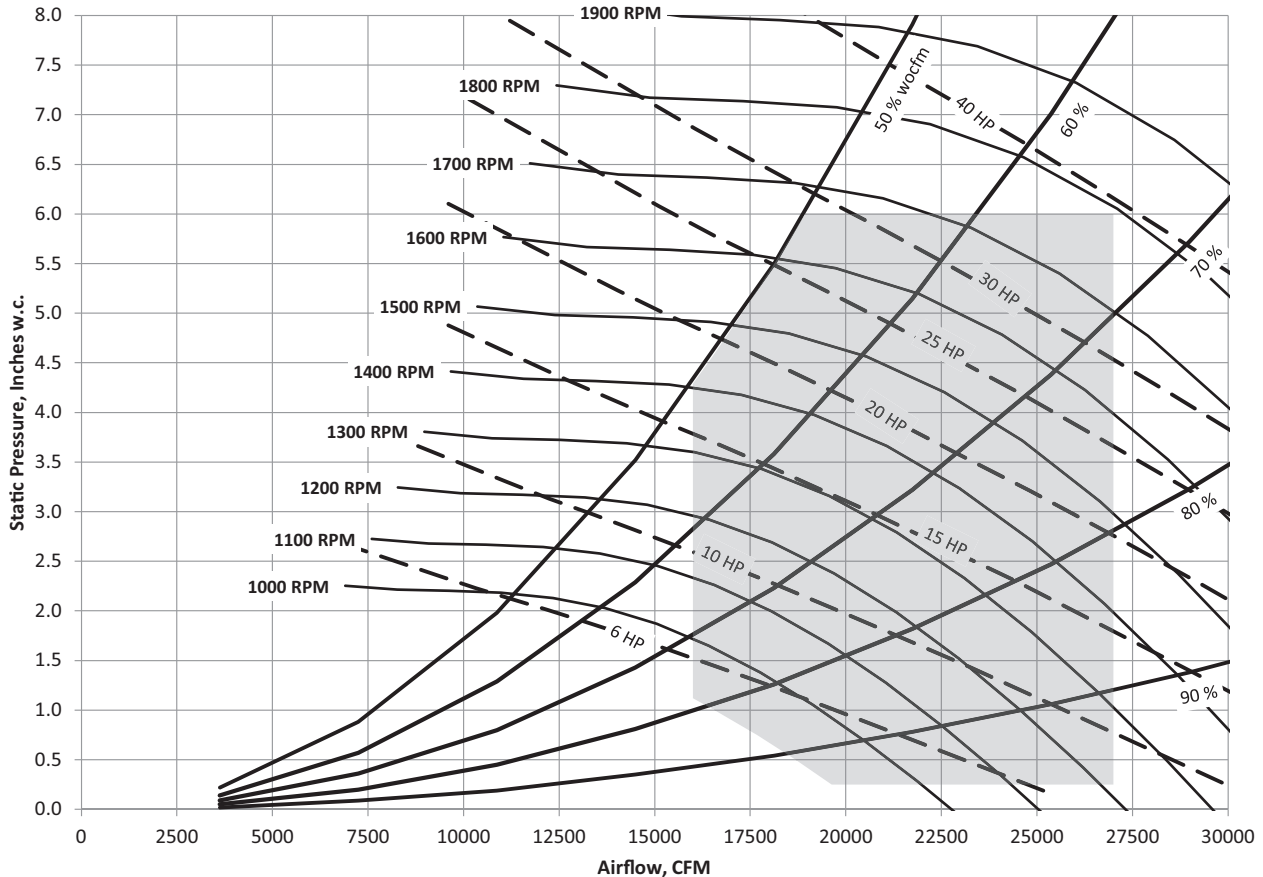

Important: Maximum static pressure leaving the rooftop is 4.0" H₂O positive. The static pressure drops from the supply fan to the space cannot exceed 4.0" H₂O.

1. Shaded areas represent selectable area. Contact your local Trane representative for more information.
2. Supply fan performance curve includes internal resistance of rooftop. For total static pressure determination, system external static must be added to appropriate component static pressure drops (evaporator coil, filters, optional economizer, optional exhaust fan, optional heating system, optional cooling only extended casing, optional roof curb).
3. Maximum Cfm (for cULus approval): 27,000 Cfm.
4. Minimum motor horsepower is 10 hp (2 x 5 hp motors)
5. Maximum motor horsepower is 50 hp (2 x 25 hp motors)
6. Maximum fan RPM is 1,900.

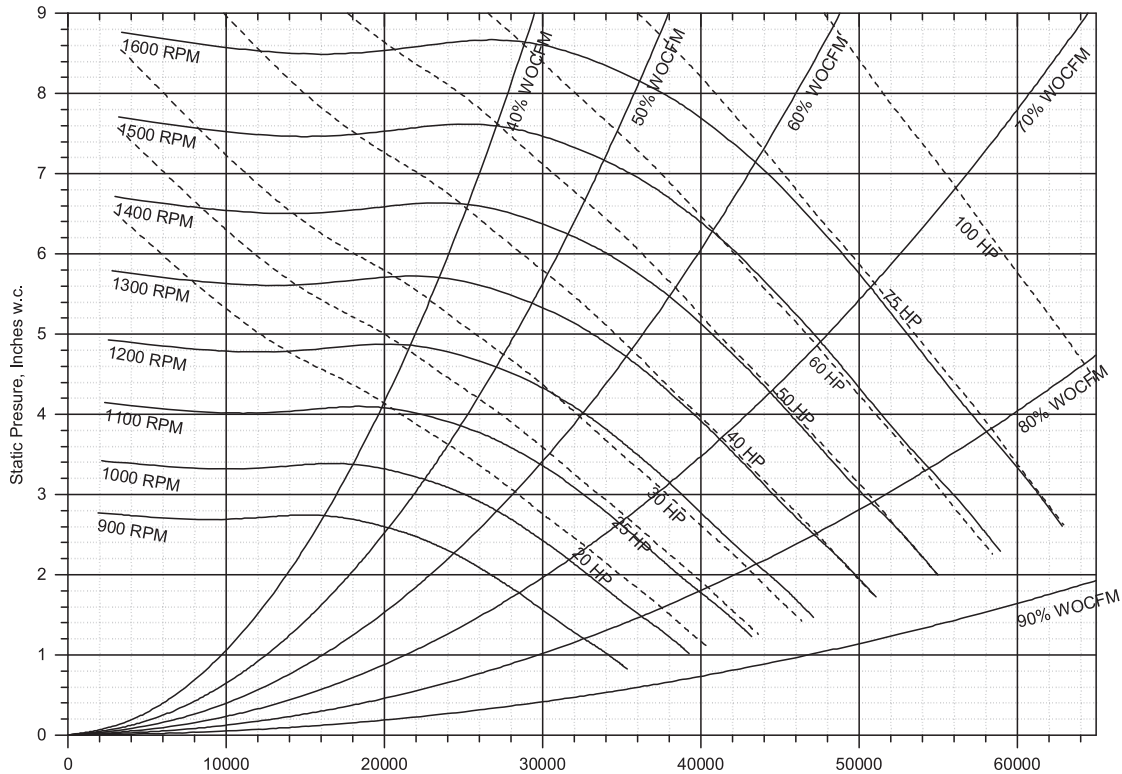
Figure 26. Supply fan performance with or without variable frequency drive - 90 ton air-cooled

Important: Maximum static pressure leaving the rooftop is 4.0" H₂O positive. The static pressure drops from the supply fan to the space cannot exceed 4.0" H₂O.

1. Supply fan performance table includes internal resistance of rooftop. For total static pressure determination, system external static must be added to appropriate component static pressure drops, (evaporator coil, filters, optional economizer, optional heating system, optional roof curb).
2. Maximum static pressure leaving the rooftop is 4.0" H₂O positive. The static pressure drops from the supply fan to the space cannot exceed 4.0" H₂O.
3. Minimum motor horsepower is 30 hp.

Performance Data

Figure 27. Supply fan performance with or without variable frequency drive - 105, 115, 130 ton air-cooled

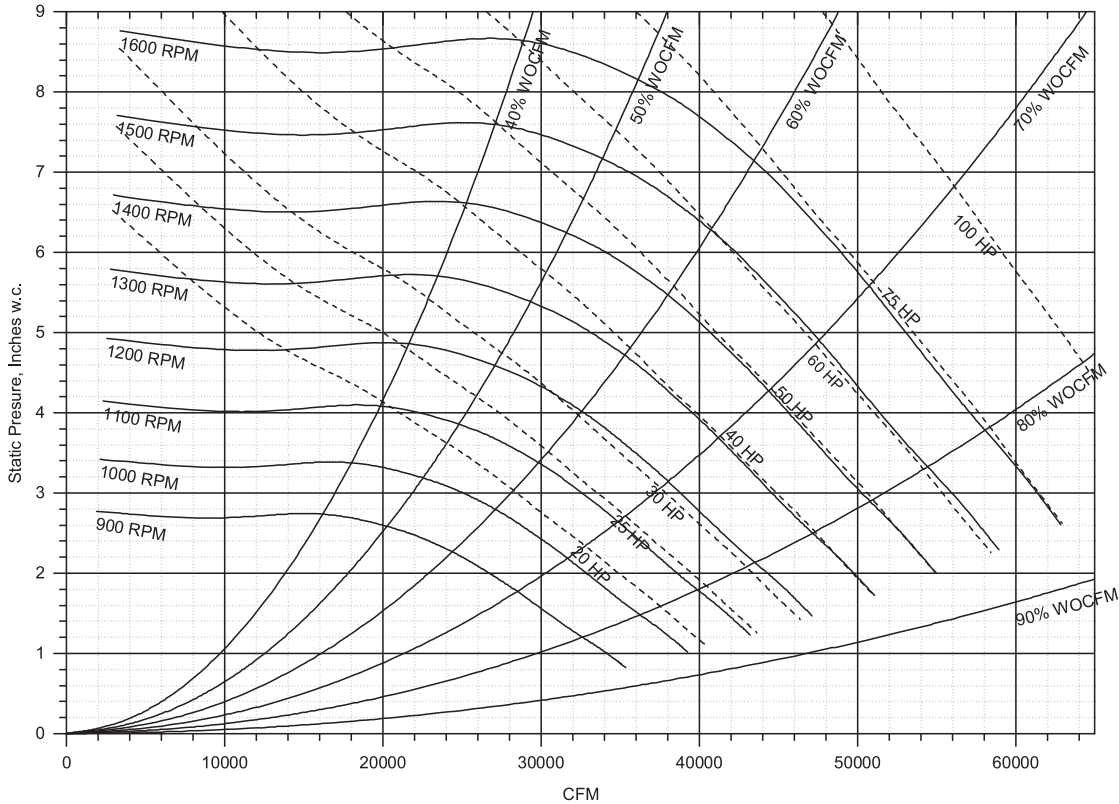

Important: Maximum static pressure leaving the rooftop is 4.0" H₂O positive. The static pressure drops from the supply fan to the space cannot exceed 4.0" H₂O.

1. Supply fan performance curve includes internal resistance of rooftop. For total static pressure determination, system external static must be added to appropriate component static pressure drops, (evaporator coil, filters, optional economizer, optional heating system, optional roof curb).
2. Maximum Cfm as follows: 105 ton standard - 44,000 Cfm, 105 high capacity, 115, 130 ton - 46,000 Cfm.
3. Minimum motor horsepower is 30 hp.

Table 54. Component static pressure drops (in. W.G.)

Nom	CFM Std	Evaporator Coil			Heating System						Filters				Std Roof	Economizer With or Without Exhaust	
		Dry	Wet	SEHL All kW	SLHL		SSHLL		Perm Wire	Bag & Prefilter	Cartridge & Prefilter	Final Filter Cartridge					
					Low	High	Low	High					Std.	High			
20	4000	0.12	0.16	.02	N/A	.05	.06	.02	.06	.03	.03	.01	.3	.24	0.22	.01	.03
	6000	0.24	0.29	.05	.05	.09	.12	.05	.12	.06	.06	.02	.5	.44	0.30	.02	.06
	8000	0.37	0.44	.09	.09	.15	.19	.10	.20	.09	.09	.03	.71	.68	0.45	.05	.12
	9000	0.45	0.52	.12	.12	.19	.24	.12	.22	.11	.11	.04	.83	.81	0.55	.07	.15
	10000	0.53	0.6	.14	.15	.23	.28	.15	.29	.13	.13	.05	.95	.95	0.66	.10	.19
	12000	0.7	0.78	.20	.22	.33	.40	.22	.42	.15	.15	.06	1.19	1.26	0.94	.14	.27
25	5000	0.18	0.22	.03	N/A	.07	.09	.04	.09	.05	.05	.02	.40	.34	0.25	.01	.03
	6000	0.24	0.29	.05	.05	.10	.12	.06	.13	.07	.07	.02	.50	.44	0.30	.02	.05
	7500	0.34	0.41	.08	.08	.14	.17	.09	.18	.09	.09	.03	.66	.62	0.41	.04	.10
	10000	0.53	0.62	.14	.15	.23	.28	.15	.29	.13	.13	.05	.95	.95	0.66	.10	.19
	11000	0.62	0.71	.17	.18	.29	.33	.19	.35	.15	.15	.06	1.06	1.11	0.79	.12	.23
	12500	0.75	0.85	.22	.23	.33	.42	.24	.42	.19	.19	.08	1.29	1.34	1.02	.19	.30
30	14000	0.9	0.99	.28	.29	.41	.53	.30	.53	.24	.24	.10	-	-	1.28	.24	.39
	6000	0.17	0.24	.05	.05	.09	.12	.05	.12	.04	.04	.01	.34	.26	0.24	.02	.06
	9000	0.33	0.45	.11	.12	.19	.24	.12	.22	.07	.07	.02	.54	.48	0.36	.07	.15
	12000	0.53	0.67	.20	.21	.31	.39	.22	.41	.11	.11	.04	.75	.75	0.58	.16	.27
	14000	0.68	0.83	.26	.29	.40	.51	.30	.50	.14	.14	.06	.95	.95	0.76	.25	.39
	15000	0.76	0.92	.30	.33	.45	.57	.33	.52	.16	.16	.07	1.03	1.06	0.87	.30	.43
40	17000	0.92	1.09	.39	.42	.58	.73	.42	.67	.21	.21	.09	1.20	1.30	1.11	.39	.59
	8000	0.19	0.26	.09	N/A	.09	.11	.05	.11	.04	.04	.02	.37	.31	0.25	.01	.03
	10000	0.27	0.36	.14	.11	.13	.16	.08	.16	.06	.06	.02	.49	.43	0.32	.02	.03
	12000	0.36	0.48	.20	.15	.17	.22	.11	.21	.08	.08	.03	.61	.56	0.41	.04	.07
	16000	0.57	0.73	.34	.26	.28	.36	.20	.36	.12	.12	.05	.88	.87	0.66	.10	.09
	17000	0.62	0.79	N/A	.29	.31	.39	.22	.41	.13	.13	.06	.95	.95	0.74	.12	.11
50-55	20000	0.81	0.99	N/A	.41	.44	.42	.52	.30	.30	.17	.08	1.17	1.22	1.02	.19	.17
	22000	0.94	1.13	N/A	.50	.53	.51	.63	.36	.36	.21	.10	-	-	1.23	.23	.20
	10000	0.2	0.25	.12	.10	.13	.16	.07	.15	.04	.04	.01	.37	.30	0.25	.03	.05
	14000	0.34	0.42	.26	.20	.22	.28	.15	.28	.07	.07	.03	.56	.50	0.37	.07	.08
	17000	0.46	0.57	.39	.29	.32	.40	.22	.41	.10	.10	.04	.72	.68	0.50	.12	.11
	20000	0.59	0.73	.58	.41	.44	.52	.30	.51	.12	.12	.05	.88	.88	0.66	.19	.17
60	24000	0.79	0.94	.73	.58	.62	.72	.45	.75	.16	.16	.07	1.11	1.17	0.94	.30	.23
	28000	1.01	1.17	.99	.79	.84	.98	.61	.99	.20	.20	.10	-	-	1.28	.39	.30
	12000	0.27	0.37	.10	.08	.10	.13	.06	.11	.05	.05	.01	.44	.37	0.27	.02	.07
	16000	0.43	0.58	.18	.14	.17	.21	.11	.19	.07	.07	.02	.63	.58	0.39	.05	.10
	20000	0.62	0.8	.27	.21	.24	.31	.16	.27	.10	.10	.03	.84	.82	0.56	.10	.16
	24000	0.83	1.03	.40	.30	.33	.42	.22	.39	.11	.11	.04	1.06	1.08	0.78	.16	.23
70	28000	1.06	1.28	.48	.33	.32	.44	.25	.50	.17	.17	.06	1.22	1.29	1.05	.30	.30
	30000	1.19	1.41	.62	.38	.37	.51	.33	.57	.20	.20	.07	-	-	1.21	.34	.34
	12000	0.28	0.37	.10	.08	.10	.13	.06	.11	.05	.05	.01	.44	.37	0.27	.02	.07
	16000	0.44	0.58	.18	.14	.17	.21	.11	.19	.07	.07	.02	.63	.58	0.39	.05	.10
	20000	0.62	0.81	.27	.21	.24	.31	.16	.27	.10	.10	.03	.84	.82	0.56	.10	.16
	22000	0.73	0.94	.33	.25	.29	.37	.19	.33	.12	.12	.04	.95	.95	0.66	.13	.20
30000	24000	0.84	1.06	.40	.30	.32	.42	.22	.39	.14	.14	.04	1.06	1.08	0.78	.16	.23
	26000	0.95	1.19	.47	.32	.39	.49	.27	.45	.16	.16	.05	1.17	1.23	0.91	.23	.26
	28000	1.07	1.32	.54	.33	.32	.44	.25	.50	.17	.17	.06	1.22	1.29	1.05	.30	.30
	31000	1.26	1.52	.60	.40	.49	.61	.39	.55	.21	.21	.07	-	-	1.29	.37	.36
	33000	1.39	1.66	.65	.46	.52	.67	.44	.60	.24	.24	.08	-	-	1.47	.42	.40

continued on next page

Table 54. Component static pressure drops (in. W.G.) (continued)

Nom	CFM Std	Evaporator Coil		Heating System						Filters				Economizer With or Without Exhaust					
		Dry	Wet	SFHL		SEHL		SLHL		SSHL		Throwaway		Perm Wire	Bag & Prefilter	Cartridge & Prefilter	Final Filter Cartridge	Std Roof	Std Exhaust
				Low	High	Low	High	Low	High	Low	High	Std.	High						
75	12000	0.28	0.38	.10	.08	0.06	.10	.13	.06	.11	.05	.05	.01	.44	.37	0.27	.02	.07	
	16000	0.44	0.58	.18	.14	0.11	.17	.21	.11	.19	.07	.07	.02	.63	.58	0.39	.05	.10	
	20000	0.63	0.82	.27	.21	0.17	.24	.31	.16	.27	.10	.10	.03	.84	.82	0.56	.10	.16	
	22000	0.73	0.94	.33	.25	0.2	.29	.37	.19	.33	.12	.12	.04	.95	.95	0.66	.13	.20	
	24000	0.84	1.07	.40	.30	0.24	.33	.42	.22	.39	.14	.14	.04	1.06	1.08	0.78	.16	.23	
	26000	0.95	1.2	.47	.32	0.28	.39	.49	.27	.45	.16	.16	.05	1.17	1.23	0.91	.23	.26	
28000	1.07	1.33	.54	.33	0.32	.44	.55	.32	.50	.17	.17	.06	1.22	1.29	1.05	.30	.30		
31000	1.27	1.54	.60	.40	0.4	.49	.61	.39	.55	.21	.21	.07	-	-	1.29	.37	.36		
33000	1.4	1.68	.65	.46	0.45	.52	.67	.44	.60	.24	.24	.08	-	-	1.47	.42	.40		

Notes:

1. Static pressure drops of accessory components must be added to external static pressure to enter fan selection tables.
2. Gas heat section maximum temperature rise of 60 F.
3. Throwaway filter option limited to 300 ft/min face velocity.
4. Bag filter option limited to 740 ft/min face velocity.
5. Horizontal roof curbs assume 0.50" static pressure drop or double the standard roof curb pressure drop, whichever is greater.
6. No additional pressure loss for model SXHL.
7. For final filters w/ prefilters (digit 13 = M, N, P, Q) also add pressure drop for throwaway filter.

Table 55. Component static pressure drops, 90-130 ton air-cooled(in. W.G.)

Nom	CFM Std	Evaporator Coil		High Cap Evap		Heating System						Filters				Economizer With or Without Exhaust					
		Dry	Wet	Dry	Wet	SFHL		SEHL		SLHL		SSHL		Throwaway		Perm Wire	Bag and Prefilter	Cartridge and Prefilter	Final Filter Cartridge	Std Roof	Std Exhaust
						Low	High	Low	High	Low	High	Low	High	Std.	High						
90	27000	0.40	0.53	0.60	0.80	-	0.25	0.13	0.26	0.31	0.22	0.32	0.11	0.13	-	0.68	0.65	0.77	-	0.2	
	32000	0.53	0.70	0.80	1.03	-	0.31	0.16	0.35	0.41	0.3	0.43	0.14	0.16	-	0.84	0.84	1.07	-	0.31	
	37000	0.67	0.88	1.01	1.32	-	0.39	0.23	0.45	0.52	0.4	0.55	0.17	0.19	-	1.02	1.04	1.43	-	0.41	
	42000	0.83	1.08	1.25	1.62	-	0.46	0.29	0.56	0.65	0.5	0.68	0.21	0.22	-	1.19	1.06	1.86	-	0.52	
105	45000	0.93	1.20	1.40	1.80	-	0.52	0.32	0.63	0.73	0.58	0.76	0.24	0.24	-	-	-	2.14	-	0.63	
	31000	-	-	0.63	0.83	-	0.28	0.17	0.33	0.39	0.29	0.4	-	0.13	-	0.82	0.8	1.00	-	0.22	
	35000	-	-	0.77	1.01	-	0.36	0.21	0.41	0.48	0.36	0.5	-	0.16	-	0.96	0.96	1.28	-	0.32	
	39000	-	-	0.92	1.20	-	0.42	0.26	0.49	0.57	0.44	0.6	-	0.19	-	1.09	1.12	1.59	-	0.44	
115/130	43000	-	-	1.08	1.40	-	0.45	0.3	0.57	0.66	0.53	0.71	-	0.22	-	1.22	1.3	1.95	-	0.54	
	46000	-	-	1.21	1.56	-	0.55	0.34	0.65	0.75	0.61	0.79	-	0.24	-	-	2.24	-	0.64		
	31000	0.76	1.00	-	-	-	0.28	0.17	0.33	0.39	0.29	0.4	-	0.13	-	0.82	0.8	1.00	-	0.22	
	35000	0.92	1.21	-	-	-	0.36	0.21	0.41	0.48	0.36	0.5	-	0.16	-	0.96	0.96	1.28	-	0.32	
130	39000	1.10	1.44	-	-	-	0.42	0.26	0.49	0.57	0.44	0.6	-	0.19	-	1.09	1.12	1.59	-	0.44	
	43000	1.30	1.68	-	-	-	0.45	0.3	0.57	0.66	0.53	0.71	-	0.22	-	1.22	1.3	1.95	-	0.54	
	46000	1.45	1.86	-	-	-	0.55	0.34	0.65	0.75	0.61	0.79	-	0.24	-	-	2.24	-	0.64		
	31000	0.76	1.00	-	-	-	0.28	0.17	0.33	0.39	0.29	0.4	-	0.13	-	0.82	0.8	1.00	-	0.22	

Notes:

1. Static pressure drops of accessory components must be added to external static pressure to enter fan selection tables.
2. Gas heat section maximum temperature rise of 60 F.
3. Throwaway filter option limited to 300 ft/min face velocity.
4. Bag filter option limited to 740 ft/min face velocity.
5. Horizontal roof curbs assume 0.50" static pressure drop or double the standard roof curb pressure drop, whichever is greater.
6. No additional pressure loss for model SXHK.
7. For final filters w/ prefilters (digit 13 = M, N, P, Q) also add pressure drop for throwaway filter.

Table 56. Component static pressure drops (in. W.G.)—exhaust damper for return fan

Nom Tons	Cfm	Exhaust Damper for Return Fan	Nom Tons	Cfm	Exhaust Damper for Return Fan
20	4000	0.08	50-55	10000	0.28
	6000	0.19		14000	0.56
	8000	0.35		17000	0.75
	9000	0.44		20000	1.15
	10000	0.55		24000	1.66
	12000	0.79		28000	2.26
25	5000	0.13	60	12000	0.31
	6000	0.19		16000	0.56
	7500	0.3		20000	0.88
	10000	0.55		24000	1.27
	11000	0.67		28000	1.73
	12500	0.85		30000	1.99
30	6000	0.19	70	12000	0.31
	9000	0.44		16000	0.56
	12000	0.79		20000	0.88
	14000	1.08		22000	1.05
	15000	1.2		24000	1.27
	17000	1.6		26000	1.47
40	8000	0.18	75	28000	1.73
	10000	0.28		31000	-
	12000	0.41		33000	-
	16000	0.73		12000	0.31
	17000	0.82		16000	0.56
	20000	1.15		20000	0.88
22000	1.39	22000	1.05		
			24000	1.27	
			26000	1.47	
			28000	1.73	
			31000	-	
			33000	-	

Notes:

1. Exhaust Damper drop is only added when Return Fan is ordered.
2. Use Return CFM for exhaust damper drop add on return fan selections.



Performance Data

Table 57. FC supply air fan drive selections — 20-75 ton

Nominal Tons	3 Hp		5 Hp		7½ Hp		10 Hp		15 Hp		20 Hp		25 Hp		30 Hp		40 Hp		50 Hp	
	RPM	Drive No	RPM	Drive No	RPM	Drive No	RPM	Drive No	RPM	Drive No	RPM	Drive No	RPM	Drive No	RPM	Drive No	RPM	Drive No	RPM	Drive No
20	500	5	700	7	900	9	1100	B	1200	C	1400	E								
	600	6	800	8	1000	A	1200	C	1300	D	1500	F								
	700	7	900	9	1100	B	1300	D	1400	E	1600	G								
	800	8	1000	A	1200	C	1400	E	1500	F	1700	H								
	900	9	1100	B	1300	D			1600	G										
25	500	5	700	7	800	8	1000	A	1200	C	1400	E								
	600	6	800	8	900	9	1100	B	1300	D	1500	F								
	700	7	900	9	1000	A	1200	C	1400	E	1600	G								
	800	8	1000	A	1100	B	1300	D	1500	F	1700	H								
	900	9	1100	B	1200	C	1400	E	1600	G										
30			600	6	700	7	800	8	900	9	1100	B								
			700	7	800	8	900	9	1000	A	1200	C								
			800	8	900	9	1000	A	1100	B	1300	D								
			900	9	1000	A	1100	B	1200	C	1400	E								
40					500	5	700	7	800	8	900	9	1000	A	1000	A				
					600	6	800	8	900	9	1000	A	1100	B	1100	B				
					700	7	900	9	1000	A	1100	B								
					800	8														
50-55					500	5	600	6	700	7	800	8	900	9	1000	A				
					600	6	700	7	800	8	900	9	1000	A	1100	B				
					700	7	800	8	900	9	1000	A	1100	B						
					800	8	900	9	1000	A	1100	B								
60, 70, 75							400	4	500	5	600	6	700	7	800	8	900	9	1000	A
							500	5	600	6	700	7	800	8	900	9	1000	A	1100	B
							600	6	700	7	800	8	900	9	1000	A	1100	B		
							700	7	800	8	900	9	1000	A						

Table 58. 80%, 100% and 120% wheel width DDP supply air fan speed ranges - 20-75ton

Nominal Tons	DDP Fan Wheel Width	Speed Range (RPM)									
		3 HP	5 HP	7.5 HP	10 HP	15 HP	20 HP	25 HP	30 HP	40 HP	50 HP
20 & 25	80%	1000-1500	1000-1700	1000-2000	1700-2200	1700-2400	1700-2400				
	120%	1000-1300	1000-1500	1000-1800	1000-1900	1700-2200	1700-2400				
30	80%	1000-1200	1000-1500	1000-1700	1000-1900	1700-2100	1700-2200				
	120%	1000-1100	1000-1300	1000-1500	1000-1600	1700-1900	1700-2100				
40	80%	1000	1000-1200	1000-1400	1000-1600	1000-1800	1700-2000	1700-2000			
	120%		1000-1100	1000-1300	1000-1400	1000-1600	1700-1800	1700-1800			
50-55	80%		1000	1000-1200	1000-1300	1000-1500	1700	1700-1800	1700-1800		
	100%								1700-1800		
	120%			1000	1000-1200	1000-1300			1700		
60	80%				1000-1500	1000-1700	1000-1900		1700-2100	1700-2200	
	120%				1000-1300	1000-1500	1000-1600		1700-1900	1700-2100	
70 & 75	80%				1000-1200	1000-1400	1000-1600		1000-1800	1700-2000	1700-2000
	120%				1000-1100	1000-1300	1000-1400		1000-1600	1700-1800	1700-1900

Note: Some RPM's will not allow bypass. Please check TOPSS on all applications.

Table 59. Air-cooled supply air fan drive selections — 90-130 ton

RPM	15 Hp Drive No.	20 Hp Drive No.	25 Hp Drive No.	30 Hp Drive No.	40 Hp Drive No.
1000	A	A			
1100	B	B	B		
1200	C	C	C	C	
1300		D	D	D	D
1400			E	E	E
1500			F	F	F
1600				G	G

Table 60. Modulating 100% exhaust fan performance — 20-75 ton

Nominal Tons	CFM Std Air	Negative Static Pressure															
		0.250		0.500		0.750		1.000		1.250		1.500		1.750		2.000	
		RPM	BHP	RPM	BHP	RPM	BHP	RPM	BHP	RPM	BHP	RPM	BHP	RPM	BHP	RPM	BHP
20	4000	379	0.34	515	0.70	622	1.12	712	1.59	791	2.10	861	2.64				
	6000	421	0.61	541	1.03	643	1.52	732	2.07	811	2.66						
	8000	487	1.10	583	1.56	674	2.11	757	2.72								
	10000	567	1.88	643	2.37	719	2.96										
25	4000	379	0.34	515	0.70	622	1.12	712	1.59	791	2.10	861	2.64	927	3.22	988	3.84
	6000	421	0.61	541	1.03	643	1.52	732	2.07	811	2.66	882	3.28	948	3.94	1010	4.64
	8000	487	1.10	583	1.56	674	2.11	757	2.72	834	3.38	904	4.09	970	4.82		
	10000	567	1.88	643	2.37	719	2.96	794	3.63	864	4.35						
	12000	651	2.98	716	3.56	779	4.18	843	4.88								
30	4000	379	0.34	515	0.70	622	1.12	712	1.59	791	2.10	861	2.64	927	3.22	988	3.84
	6000	421	0.61	541	1.03	643	1.52	732	2.07	811	2.66	882	3.28	948	3.94	1010	4.64
	8000	487	1.10	583	1.56	674	2.11	757	2.72	834	3.38	904	4.09	970	4.82	1030	5.59
	10000	567	1.88	643	2.37	719	2.96	794	3.63	864	4.35	931	5.11	993	5.91	1053	6.77
	12000	651	2.98	716	3.56	779	4.18	843	4.88	905	5.64	967	6.47	1026	7.34		
	14000	736	4.47	796	5.17	850	5.83	904	6.57	960	7.38						
40	7500	318	0.67	444	1.21	545	1.85	629	2.54	702	3.27	767	4.02	828	4.83	884	5.66
	9000	331	0.97	444	1.47	543	2.17	628	2.94	702	3.75	770	4.60	831	5.48	887	6.37
	12000	381	2.13	460	2.40	546	3.04	627	3.89	701	4.83	769	5.82	831	6.87	889	7.93
	14000	422	3.40	486	3.49	557	3.98	631	4.76	701	5.72	768	6.78	830	7.90	888	9.07
	16000	468	5.12	520	5.07	579	5.37	643	6.01	707	6.88	769	7.92	829	9.08	887	10.32
50-55	9000	331	0.97	444	1.47	543	2.17	628	2.94	702	3.75	770	4.60	831	5.48	887	6.37
	12000	381	2.13	460	2.40	546	3.04	627	3.89	701	4.83	769	5.82	831	6.87	889	7.93
	15000	445	4.20	502	4.21	567	4.61	636	5.32	704	6.26	769	7.32	830	8.47	888	9.67
	18000	516	7.41	559	7.19	609	7.32	662	7.76	719	8.49	776	9.44	833	10.56	887	11.79
	20000	566	10.31	602	9.91	644	9.88	690	10.15	739	10.69	789	11.48	841	12.48	893	13.68
60, 70 & 75	12000	351	1.49	423	2.09	502	3.00	572	4.02	634	5.07	690	6.09	740	7.04	784	7.91
	15000	412	2.68	460	3.15	521	3.96	585	5.02	646	6.24	702	7.53	749	8.83	801	10.14
	18000	478	4.41	516	4.88	557	5.54	607	6.49	662	7.66	715	9.01	766	10.48	814	12.01
	21000	549	6.75	578	7.36	612	7.92	647	8.71	688	9.77	735	11.03	781	12.46	827	14.03
	24000	617	9.83	644	10.59	672	11.22	702	11.88	732	12.77	766	13.89	805	15.22	846	16.72
	27000	688	15.11	711	15.09	736	15.45	761	16.18	788	17.02	815	17.92	844	18.99	876	20.31

Performance Data

Table 61. Air-cooled modulating 100% exhaust fan performance – 90-130 ton

Nominal Tons	CFM Std Air	Negative Static Pressure																			
		0.250		0.500		0.750		1.000		1.250		1.500		1.750		2.000		2.250		2.500	
		RPM	BHP	RPM	BHP	RPM	BHP	RPM	BHP	RPM	BHP	RPM	BHP	RPM	BHP	RPM	BHP	RPM	BHP	RPM	BHP
90-130	28000	495	12.81	519	13.30	547	13.93	582	15.27	619	17.14	655	18.85	689	20.51	721	22.51	750	24.43	777	26.28
	30000	527	15.67	550	16.22	573	16.71	604	17.84	637	19.53	672	21.63	705	23.38	737	25.16	768	27.31	795	29.37
	32000	559	18.92	581	19.53	602	20.03	628	20.90	658	22.39	690	24.39	723	26.63	753	28.44	784	30.37	811	32.54
	34000	591	22.60	612	23.28	632	23.84	653	24.48	681	25.74	710	27.55	739	29.75	771	32.16	799	34.04	828	36.04
	36000	623	26.73	643	27.47	662	28.09	680	28.62	705	29.66	732	31.25	759	33.29	788	35.76	817	38.26	844	40.23
	38000	656	31.34	675	32.14	693	32.83	710	33.42	730	34.17	755	35.51	780	37.38	806	39.60	834	42.26	861	44.90
	40000	688	36.46	707	37.31	724	38.07	741	38.73	757	39.29	779	40.45	804	42.09	827	44.14	853	46.63	879	49.41

Notes:

1. Shaded areas indicate non-standard drive selections. These drive selections must be manually factory selected.
2. Refer to General Data Table for minimum and maximum hp's.

Table 62. 100% Exhaust fan drive selections – 20-75 ton

Nominal Tons	3 Hp		5 Hp		7½ Hp		10 Hp		15 Hp		20 Hp	
	RPM	Drive No	RPM	Drive No	RPM	Drive No	RPM	Drive No	RPM	Drive No	RPM	Drive No
20	500	5										
	600	6										
	700	7										
	800	8										
	900	9										
25	500	5	700	7								
	600	6	800	8								
	700	7	900	9								
	800	8	1000	A								
	900	9										
30	500	5	700	7	800	8						
	600	6	800	8	900	9						
	700	7	900	9	1000	A						
	800	8	1000	A	1100	B						
	900	9										
40			400	4	600	6	700	7				
			500	5	700	7	800	8				
			600	6	800	8						
			700	7								
			800	8								
50			400	4	600	6	700	7	700	7		
			500	5	700	7	800	8	800	8		
			600	6	800	8			900	9		
			700	7								
			800	8								
60			400	4	600	6	600	6	700	7	800	8
70			500	5	700	7	700	7	800	8		
75			600	6								

Table 63. Air-cooled 100% exhaust fan drive selections – 90-130 ton

Nominal Tons	15 HP		20 HP		25 HP		30 HP		40 HP	
	RPM	Drive No	RPM	Drive No	RPM	Drive No	RPM	Drive No	RPM	Drive No
90-130	500	5	500	5	600	6	600	6	700	7
	600	6	600	6	700	7	700	7	800	8
			700	7	800	8	800	8		

Table 64. 50% Exhaust fan performance – 20-75 ton

Nominal Tons	CFM Std Air	Negative Static Pressure (In. W.G.)													
		0.200		0.400		0.600		0.800		1.000		1.200		1.400	
		RPM	BHP	RPM	BHP	RPM	BHP	RPM	BHP	RPM	BHP	RPM	BHP	RPM	BHP
20, 25	2000	346	0.14	465	0.27	560	0.43	641	0.60	712	0.79	776	1.00	836	1.21
	3000	397	0.27	495	0.42	583	0.61	662	0.81	731	1.03	795	1.27	854	1.51
	4000	469	0.51	546	0.68	621	0.88	691	1.11	757	1.36	818	1.62	876	1.90
	5000	548	0.88	613	1.08	675	1.30	736	1.55	794	1.81	850	2.10	903	2.39
	6000	630	1.40	690	1.66	742	1.90	793	2.16	844	2.45	894	2.75	943	3.06
30	2000	346	0.14	465	0.27	560	0.43	641	0.60	712	0.79	776	1.00	836	1.21
	3000	397	0.27	495	0.42	583	0.61	662	0.81	731	1.03	795	1.27	854	1.51
	4000	469	0.51	546	0.68	621	0.88	691	1.11	757	1.36	818	1.62	876	1.90
	5000	548	0.88	613	1.08	675	1.30	736	1.55	794	1.81	850	2.10	903	2.39
	6000	630	1.40	690	1.66	742	1.90	793	2.16	844	2.45	894	2.75	943	3.06
	7000	714	2.10	769	2.42	818	2.72	862	3.00	906	3.29	950	3.61	993	3.95
40-55,	3000	281	0.20	396	0.39	486	0.60	560	0.83	625	1.07	683	1.33	737	1.61
	5000	326	0.55	404	0.73	485	0.99	559	1.29	627	1.61	687	1.94	741	2.28
	7000	411	1.35	459	1.51	513	1.74	571	2.04	629	2.39	686	2.77	740	3.18
	9000	508	2.80	540	2.92	578	3.13	618	3.40	662	3.72	706	4.09	751	4.50
	11000	609	5.05	633	5.16	661	5.34	691	5.58	723	5.87	756	6.21	792	6.59
60, 70, 75	4000	271	0.29	364	0.54	438	0.82	499	1.07	550	1.30	601	1.56	651	1.87
	6000	339	0.71	391	0.90	456	1.22	517	1.60	572	2.01	622	2.43	668	2.85
	8000	425	1.55	460	1.73	497	1.96	542	2.30	591	2.72	639	3.20	684	3.73
	10000	517	2.88	543	3.13	571	3.34	600	3.59	632	3.94	649	4.37	707	4.87
	12000	612	4.84	651	5.15	655	5.43	678	5.68	702	5.95	726	6.29	752	6.71
	13000	659	6.09	679	6.44	699	6.76	720	7.04	741	7.31				

Table 65. Air-cooled 50% exhaust fan performance – 90-130 ton

CFM Nominal Tons	Std Air	Negative Static Pressure (In. W.G.)																			
		0.250		0.500		0.750		1.000		1.250		1.500		1.750		2.000		2.250		2.500	
		RPM	BHP	RPM	BHP	RPM	BHP	RPM	BHP	RPM	BHP	RPM	BHP	RPM	BHP	RPM	BHP	RPM	BHP	RPM	BHP
90-130	12000	432	4.09	461	4.31	502	4.86	545	5.67	585	6.35	622	7.19	655	7.99	686	8.78	717	9.57	748	10.48
	14000	495	6.40	519	6.65	547	6.96	582	7.64	619	8.57	655	9.42	689	10.26	721	11.26	750	12.21	777	13.14
	16000	559	9.46	581	9.77	602	10.02	628	10.45	658	11.20	690	12.19	723	13.32	753	14.22	784	15.18	811	16.27
	18000	623	13.36	643	13.73	662	14.05	680	14.31	705	14.83	732	15.63	759	16.65	788	17.88	817	19.13	844	20.12
	20000	688	18.23	707	18.66	724	19.03	741	19.36	757	19.65	779	20.22	804	21.04	827	22.07	853	23.31	879	24.70

Note: Shaded areas indicate non-standard drive selections. These drive selections must be manually factory selected.

Performance Data

Table 66. 50% Exhaust fan drive selections

Nominal Unit Size	3 HP		5 HP		7½ HP		15 HP	
	RPM	Drive No	RPM	Drive No	RPM	Drive No	RPM	Drive No
20, 25	500	5						
	600	6						
	700	7						
	800	8						
	900	9						
30	500	5	800	8				
	600	6	900	9				
	700	7	1000	A				
	800	8						
	900	9						
40-55,			500	5	600	6		
			600	6	700	7		
			700	7				
60, 70, 75			400	4	700	7		
			500	5				
			600	6				
90-130							500	5
							600	6
							700	7
							800	8

Table 67. Return fan performance—20, 25, 30 ton air-cooled (24.5" Fan)

CFM Std. Air	Return Fan Static Pressure Including Exhaust Damper P.D.															
	0.25		0.50		0.75		1.00		1.25		1.50		1.75		2.00	
	RPM	BHP	RPM	BHP	RPM	BHP	RPM	BHP	RPM	BHP	RPM	BHP	RPM	BHP	RPM	BHP
4000	557	0.29	638	0.48	710	0.68	776	0.89	838	1.10	899	1.32	969	1.60	1038	1.89
4500	605	0.36	682	0.57	749	0.79	811	1.02	869	1.25	926	1.49	980	1.73	1033	1.99
5000	654	0.44	727	0.67	790	0.91	850	1.16	905	1.41	957	1.67	1007	1.93	1057	2.20
5500	704	0.53	773	0.79	834	1.04	889	1.30	943	1.58	992	1.86	1040	2.15	1087	2.44
6000	756	0.64	821	0.92	879	1.20	932	1.47	982	1.77	1030	2.06	1076	2.38	1121	2.70
6500	808	0.76	868	1.06	925	1.36	976	1.66	1024	1.97	1070	2.29	1114	2.61	1157	2.95
7000	861	0.90	917	1.21	972	1.55	1021	1.87	1067	2.19	1112	2.53	1154	2.87	1195	3.22
7500	913	1.06	968	1.39	1019	1.74	1068	2.10	1112	2.44	1155	2.79	1196	3.15	1235	3.51
8000	967	1.24	1019	1.58	1068	1.96	1115	2.34	1158	2.71	1199	3.08	1238	3.45	1277	3.84
8500	1021	1.44	1071	1.80	1116	2.19	1162	2.60	1204	3.00	1244	3.39	1283	3.79	1320	4.19
9000	1075	1.67	1123	2.04	1166	2.45	1210	2.88	1252	3.30	1290	3.72	1327	4.14	1363	4.56
9500	1130	1.92	1175	2.31	1217	2.73	1258	3.17	1299	3.62	1337	4.07	1373	4.52	1408	4.96
10000	1186	2.20	1228	2.60	1269	3.04	1307	3.50	1347	3.97	1384	4.45	1419	4.91	1454	5.38
10500	1241	2.50	1280	2.92	1321	3.37	1357	3.85	1395	4.34	1432	4.85	1466	5.33	1500	5.84
11000	1297	2.84	1334	3.27	1373	3.74	1409	4.23	1443	4.74	1480	5.26	1515	5.79	1546	6.29
11500	1353	3.20	1387	3.64	1425	4.13	1460	4.64	1493	5.16	1528	5.71	1561	6.25	1594	6.79
12000	1408	3.60	1441	4.06	1477	4.56	1512	5.08	1544	5.62	1576	6.18	1610	6.75	1642	7.32
12500	1464	4.03	1496	4.50	1530	5.01	1565	5.56	1596	6.11	1626	6.68	1658	7.28	1689	7.87
13000	1520	4.49	1551	4.98	1583	5.51	1617	6.06	1648	6.64	1677	7.22	1707	7.84	1737	8.44
13500	1576	4.99	1606	5.50	1636	6.03	1669	6.60	1700	7.20	1728	7.80	1756	8.42	1785	9.06
14000	1633	5.52	1661	6.05	1690	6.60	1721	7.19	1752	7.79	1780	8.42	1807	9.05	1834	9.70

Notes:

1. Max fan RPM 1715 for 24.5" Class I Fan
2. Max motors Available are as follows: 20T: 3HP, 25T: 5HP, 30T: 7.5 HP
3. Max CFM available is as follows; 20T: 9000, 25T: 11000, & 30T: 13500
4. Min CFM is 4000 for 20T, 25T, & 30T
5. Return fan belt drive RPM selections will be available to cover 500-1600 RPM range +/- 50 RPM
6. Performance data includes cabinet and rain hood effect. Damper pressure drop must be added to the return duct static per [Table 56, p. 107](#)
7. Outlined area indicates nonstandard BHP or RPM selections. Contact a local Trane representative for more information.



Performance Data

Table 68. Return fan performance—40, 50 and 55 ton air-cooled (27" Fan)

CFM Std. Air	Return Fan Static Pressure Including Exhaust Damper P.D.															
	0.25		0.50		0.75		1.00		1.25		1.50		1.75		2.00	
	RPM	BHP	RPM	BHP	RPM	BHP	RPM	BHP	RPM	BHP	RPM	BHP	RPM	BHP	RPM	BHP
7500	709	0.82	766	1.16	815	1.50	861	1.85	906	2.22	949	2.60	991	2.99	1033	3.39
8000	748	0.95	803	1.31	851	1.67	895	2.04	938	2.43	979	2.82	1018	3.22	1058	3.64
8500	788	1.09	840	1.47	887	1.86	930	2.24	971	2.64	1010	3.05	1049	3.48	1087	3.92
9000	827	1.24	878	1.64	924	2.05	965	2.46	1005	2.88	1043	3.31	1080	3.75	1115	4.19
9500	867	1.41	916	1.83	961	2.27	1001	2.70	1040	3.14	1076	3.58	1112	4.03	1146	4.50
10000	908	1.60	955	2.04	999	2.50	1038	2.95	1075	3.41	1111	3.88	1145	4.34	1179	4.83
10500	948	1.81	994	2.27	1036	2.75	1075	3.23	1111	3.70	1145	4.18	1179	4.68	1212	5.18
11000	989	2.04	1033	2.51	1074	3.01	1112	3.51	1147	4.01	1181	4.51	1213	5.02	1245	5.53
11500	1030	2.28	1072	2.78	1112	3.29	1149	3.82	1184	4.33	1216	4.86	1248	5.38	1279	5.92
12000	1071	2.55	1112	3.06	1151	3.59	1187	4.14	1221	4.69	1253	5.24	1284	5.78	1314	6.33
12500	1112	2.83	1152	3.37	1189	3.92	1225	4.48	1258	5.06	1290	5.62	1320	6.19	1349	6.76
13000	1153	3.14	1192	3.70	1228	4.27	1263	4.86	1296	5.45	1327	6.04	1356	6.63	1385	7.23
13500	1194	3.47	1232	4.05	1267	4.63	1301	5.24	1333	5.85	1364	6.47	1393	7.08	1421	7.70
14000	1236	3.83	1272	4.42	1307	5.03	1340	5.66	1371	6.29	1401	6.94	1430	7.57	1457	8.20
14500	1277	4.21	1313	4.82	1346	5.45	1379	6.10	1410	6.75	1439	7.42	1467	8.08	1494	8.73
15000	1319	4.62	1353	5.25	1386	5.90	1417	6.55	1448	7.23	1477	7.92	1504	8.61	1531	9.29
15500	1361	5.05	1394	5.71	1426	6.37	1457	7.05	1486	7.74	1514	8.44	1542	9.16	1569	9.87
16000	1402	5.51	1435	6.18	1466	6.87	1496	7.57	1525	8.28	1553	9.01	1580	9.74	1606	10.47
16500	1444	6.00	1476	6.69	1506	7.40	1535	8.12	1564	8.85	1591	9.58	1617	10.34	1643	11.10
17000	1486	6.52	1517	7.23	1547	7.96	1575	8.70	1603	9.44	1629	10.20	1655	10.97	1681	11.75
17500	1528	7.07	1558	7.80	1587	8.55	1615	9.30	1642	10.07	1668	10.85	1694	11.64	1718	12.43
18000	1570	7.65	1599	8.40	1627	9.17	1655	9.94	1681	10.73	1707	11.53	1732	12.33	1757	13.15
18500	1612	8.26	1640	9.03	1668	9.81	1695	10.62	1721	11.43	1746	12.23	1771	13.07	1794	13.89
19000	1654	8.91	1682	9.70	1709	10.50	1735	11.31	1760	12.14	1785	12.97	1809	13.82	1833	14.67
19500	1696	9.59	1723	10.40	1749	11.22	1775	12.06	1800	12.90	1825	13.76	1848	14.62	1872	15.50
20000	1738	10.30	1765	11.13	1790	11.97	1816	12.83	1840	13.69	1864	14.56	1888	15.46	1910	16.34
20500	1780	11.05	1806	11.90	1831	12.76	1856	13.63	1880	14.52	1903	15.41	1926	16.31	1949	17.22
21000	1822	11.84	1848	12.71	1872	13.59	1897	14.48	1920	15.39	1943	16.29	1966	17.23	1988	18.14
21500	1864	12.66	1889	13.55	1914	14.45	1937	15.36	1960	16.29	1983	17.22	2005	18.16	2027	19.11
22000	1899	13.05	1926	14.11	1952	15.16	1977	16.20	2001	17.23	2024	18.24	2047	19.27	2069	20.28
22500	1941	13.91	1967	14.98	1992	16.05	2017	17.12	2041	18.19	2064	19.23	2086	20.27	2108	21.31

Notes:

1. Max fan RPM 1981 For 27" Class II Fan
2. Max Motor Available 15 HP For 27" Fan Size
3. Max motors Available are as follows: 40T: 10 HP & 50-55T: 15 HP
4. Max CFM is as follows: 40T: 18000, 50-55T: 22500
5. Min CFM is as follows: 40T: 7500, 50-55T: 9000
6. Return fan belt drive RPM selections will be available to cover 700-1900 RPM range +/- 50 RPM
7. Performance data includes cabinet and rain hood effect. Damper pressure drop will have to be added to the return duct static per [Table 56, p. 107](#)
8. Outlined area indicates nonstandard BHP or RPM selections. Contact a local Trane representative for more information.

Table 69. Return fan performance—60-75 ton air-cooled (36.5" fan)

CFM Std. Air	Return Fan Static Pressure Including Exhaust Damper P.D.															
	0.25		0.50		0.75		1.00		1.25		1.50		1.75		2.00	
	RPM	BHP	RPM	BHP	RPM	BHP	RPM	BHP	RPM	BHP	RPM	BHP	RPM	BHP	RPM	BHP
12000	459	1.07	502	1.59	541	2.13	578	2.71	613	3.31	647	3.91	681	4.54	713	5.20
13000	490	1.27	530	1.83	567	2.40	603	3.01	636	3.65	668	4.29	700	4.94	731	5.64
14000	520	1.49	560	2.09	595	2.70	628	3.34	660	3.99	691	4.69	721	5.38	751	6.10
15000	552	1.73	590	2.38	623	3.03	655	3.70	686	4.39	715	5.11	744	5.85	771	6.59
16000	583	2.00	619	2.70	652	3.39	682	4.09	712	4.82	740	5.57	767	6.34	794	7.14
17000	615	2.30	650	3.05	681	3.78	710	4.52	739	5.28	766	6.06	792	6.85	818	7.67
18000	646	2.64	680	3.43	711	4.20	739	4.98	766	5.78	792	6.60	817	7.41	842	8.27
19000	678	3.01	711	3.85	741	4.67	768	5.48	794	6.31	819	7.16	844	8.03	867	8.89
20000	711	3.42	742	4.30	771	5.17	797	6.02	823	6.90	847	7.77	871	8.66	894	9.59
21000	743	3.87	773	4.78	801	5.70	827	6.60	852	7.51	875	8.41	898	9.36	920	10.30
22000	775	4.36	805	5.31	832	6.28	857	7.22	881	8.17	904	9.11	926	10.09	947	11.06
23000	808	4.89	836	5.88	863	6.90	887	7.89	911	8.88	933	9.87	954	10.86	975	11.88
24000	840	5.46	868	6.49	894	7.56	918	8.60	941	9.63	962	10.67	983	11.71	1004	12.75
25000	873	6.08	900	7.15	925	8.26	948	9.35	970	10.42	992	11.49	1012	12.59	1032	13.67
26000	906	6.75	931	7.86	956	9.00	979	10.16	1001	11.28	1021	12.37	1041	13.49	1061	14.63
27000	939	7.47	963	8.62	987	9.79	1010	11.01	1031	12.18	1052	13.33	1071	14.47	1090	15.65

Notes:

1. Max fan RPM 1151 for 36.5" Class I Fan
2. Max motor available 20 HP for 36.5" fan size
3. Max motor available 20 HP for 60, 70 & 75T
4. Max CFM is 27000 for 60, 70 & 75T
5. Min CFM is 12000 for 60, 70 & 75T
6. Return fan belt drive RPM selections will be available to cover 500-1100 RPM range +/- 50 RPM
7. Performance data includes cabinet and rain hood effect. Damper pressure drop will have to be added to the return duct static per table [Table 56](#), p. 107

Performance Data

Table 70. 100% return fan drive selections – 20-75 ton air-cooled

Nominal Tons	3 Hp		5 Hp		7½ Hp		10 Hp		15 Hp		20 Hp	
	RPM	Drive No.	RPM	Drive No.	RPM	Drive No.	RPM	Drive No.	RPM	Drive No.	RPM	Drive No.
20	500	5										
	600	6										
	700	7										
	800	8										
	900	9										
	1000	A										
	1100	B										
	1200	C										
25	500	5	1100	B								
	600	6	1200	C								
	700	7	1300	D								
	800	8	1400	E								
	900	9	1500	F								
	1000	A	1600	G								
	1100	B										
	1200	C										
30	500	5	1100	B	1400	E						
	600	6	1200	C	1500	F						
	700	7	1300	D	1600	G						
	800	8	1400	E								
	900	9	1500	F								
	1000	A	1600	G								
	1100	B										
	1200	C										
40			700	7	1200	C	1400	E				
			800	8	1300	D	1500	F				
			900	9	1400	E	1600	G				
			1000	A	1500	F	1700	H				
			1100	B								
			1200	C								
			1300	D								
50-55			700	7	1200	C	1400	E	1600	G		
			800	8	1300	D	1500	F	1700	H		
			900	9	1400	E	1600	G	1800	J		
			1000	A	1500	F	1700	H	1900	K		
			1100	B								
			1200	C								
60			500	5	700	7	800	8	900	9	1100	B
			600	6	800	8	900	9	1000	A		
			700	7	900	9	1000	A	1100	B		
			800	8								
70, 75			500	5	700	7	800	8	900	9	1100	B
			600	6	800	8	900	9	1000	A		
			700	7	900	9	1000	A	1100	B		
			800	8								

Controls

Rapid Restart (RR) Only

The IntelliPak™ controls platform will support Rapid Restart unit startup after every power cycle occurs. There will be no assumptions about how long the unit has been OFF, so the unit will perform the same startup sequence with each occurrence.

The following is a list of the control operations:

1. This is a cooling only function and will not function with heating.
2. RR will target a 4 minute maximum time from start signal to 100% cooling with an upper limit of 5 minutes.
3. Outside air temperatures relative to the Low Ambient Lockout Setpoint will determine whether economizer cooling or DX staging will be the primary source for cooling.
4. The use of economizing below low ambient lockout (typically 50°F) during the RR function will be a selectable option on the HI.
5. Until the RR termination conditions are met, the unit will ramp the outside air damper open, if under economizer operation. Until the RR termination conditions are met, the unit will stage DX mechanical cooling, if available, at 6 second intervals.
6. Supply fan capacity will increase accordingly:
 - CV & SZVAV: Supply fan operation at full airflow will be utilized.
 - VAV: Once the supply fan proving switch is closed, the supply fan speed will ramp to 50% command, then control to normal discharge static pressure control limited by the high duct static limit.
7. Building pressure will always be in control.
8. The unit will indicate via local HI and remote BAS that the RR event is active.
9. Valid RR temperature sensor or return air temperature sensor is required to determine initialization and deactivation of RR relative to RR Critical Temperature Setpoint. If this sensor fails, the unit will terminate RR when the discharge temperature sensor indicates a value below the active SA Cooling Setpoint – ½ deadband.
10. Limit OA Humidity infiltration to humidity greater than 20% RH.

Variable Air Volume (VAV) Only

Sequence Of Operation

Note: When noted in this sequence "Human Interface Panel," the reference is to both the unit-mounted and remote-mounted Human Interface Panel. All setpoint adjustments can be accomplished at the unit or Remote Human Interface Panel.

Supply Air Pressure Control

VFD Control

Variable frequency drives are driven by a modulating 0-10 VDC signal from the Rooftop Module (RTM). A pressure transducer measures duct static pressure, and the VFD is modulated to maintain the supply air static pressure within an adjustable user-defined range. The range is determined by the supply air pressure setpoint and supply air pressure deadband, which are set through the Human Interface Panel. Variable frequency drives provide supply fan motor speed modulation. The drive will accelerate or decelerate as required to maintain the supply static pressure setpoint.

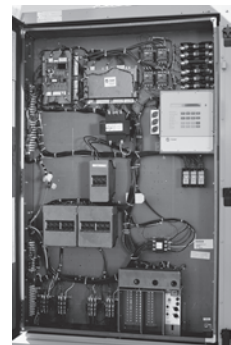

When subjected to high ambient return conditions the VFD shall reduce its output frequency to maintain operation. Bypass control is offered to provide full nominal airflow in the event of drive failure.

Supply Air Static Pressure Limit

The opening of the VAV boxes are coordinated during unit startup and transition to/from Occupied/Unoccupied modes to prevent overpressurization of the supply air ductwork. However, if for any reason the supply air pressure exceeds the user-defined supply air static pressure limit that was set at the Human Interface Panel, the supply fan/VFD is shut down. The unit is then allowed to restart three times. If the overpressurization condition occurs on the third time, the unit is shut down and a manual reset diagnostic is set and displayed at the Human Interface Panel.

Supply Air Temperature Controls

Cooling/Economizer

During Occupied cooling mode of operation, the economizer (if available) and mechanical cooling are used to control the supply air temperature. The supply air temperature setpoint and deadband are user-defined at the Human Interface Panel. If the enthalpy of the outside air is appropriate to use "free cooling," the economizer will be used first to attempt to satisfy the supply air setpoint; then if required the mechanical cooling will be staged on to maintain supply air temperature setpoint. Minimum On/Off timing of the mechanical cooling prevents rapid cycling.

On units with economizer, a call for cooling will modulate the fresh air dampers open. The rate of economizer modulation is based on deviation of the discharge temperature from setpoint, i.e., the further away from setpoint, the faster the fresh air damper will open. First stage of cooling will be allowed to start after the economizer reaches full open.

Note that the economizer is only allowed to function freely if one of the following conditions is met. For dry bulb economizer control the ambient temperature must be below the dry bulb temperature control setting. For reference enthalpy economizer control, outdoor air enthalpy must be below the enthalpy control setting. For comparative enthalpy economizer control, outdoor air enthalpy must be below the enthalpy of the return air.

At outdoor air conditions above the enthalpy control setting, mechanical cooling only is used and the fresh air dampers remain at minimum position.

If the unit does not include an economizer, mechanical cooling only is used to satisfy cooling requirements. Outdoor air dampers may be set manually for a maximum of 25 percent outdoor air, if rooftop is equipped with 0 to 25 percent manual fresh air damper.

Heating: Hot Water or Steam

On units with hot water or steam heating, the supply air temperature can be controlled to a heating set point during the Occupied mode. The supply air temperature heating set point and deadband are user-defined at the Human Interface Panel. Discharge Temperature Control occupied heating on hot water and steam heat units is enabled by closing a field-supplied switch or contacts connected to a changeover input on the RTM.

Heating: Modulating Gas

Upon a call for heating, the UCM closes the heating contacts, beginning the firing sequence. First, the heat exchanger combustion blower begins operation. Upon positive proving of combustion airflow, a pre-purge cycle is executed. Then the ignition sequence takes place.

If ignition is not proven, the ignition transformer is de-energized. After a time delay, another pre-purge cycle takes place, followed by another attempt to ignite. If ignition fails a second time, the heating section will be shut down and locked out until manually reset at the unit mounted Human Interface Panel.

As additional heat is required, the air damper opens, increasing the firing rate. During heating operation, an electronic flame safety control provides continuous flame supervision. If combustion

should become unstable for any reason, heating will automatically shut down. After one minute, another 60 second pre-purge and ignition cycle begins. As the heating requirement is satisfied, the UCM will reduce the combustion air and the firing rate will lower to maintain the desired outlet temperature. When the requirement is fully satisfied, the heating contacts are opened, de-energizing the heat. The specific sequence of operation of the gas heat will depend on the size of the heat exchanger.

Supply Air Setpoint Reset

Supply air reset can be used to adjust the supply air temperature setpoint on the basis of a zone temperature or on outdoor air temperature. Supply air reset adjustment is available from the Human Interface Panel for supply air heating and supply air cooling control.

A - reset based on outdoor air temperature. Outdoor air cooling reset is sometimes used in applications where the outdoor temperature has a large effect on building load. When the outside air temperature is low and the building cooling load is low, the supply air setpoint can be raised, thereby preventing subcooling of critical zones. This reset can lower usage of mechanical cooling, thus savings in compressor kW, but an increase in supply fan kW may occur.

Outdoor air heating reset is the inverse of cooling, with the same principles applied. For both outdoor air cooling reset and heating reset, there are three user defined parameters that are adjustable through the Human Interface Panel.

- beginning reset temperature
- ending reset temperature
- maximum amount of temperature reset

B - reset based on zone temperature. Zone reset is applied to the zone(s) in a building that tend to overcool or overheat. The supply air temperature setpoint is adjusted based on the temperature of the critical zone(s). This can have the effect of improving comfort and/or lowering energy usage. The user-defined parameters are the same as for outdoor air reset.

Zone Temperature Control

Unoccupied Zone Heating and Cooling

During Unoccupied mode, the unit is operated as a CV unit. VAV boxes are driven full open. The unit controls zone temperature within the Unoccupied zone cooling and heating (heating units only) deadbands.

Daytime Warm-up

This feature is available on all types of heating units. During Occupied mode, if the zone temperature falls to a preset, user-defined zone low limit temperature setpoint the unit is put into Unoccupied mode and Daytime Warm-up is initiated. The system changes over to CV zone temperature control heating (full unit airflow), the VAV boxes are fully opened and full heating capacity is provided until the Daytime Warm-up setpoint is reached. The unit is then returned to normal Occupied mode.

Outdoor Air CFM Compensation

The purpose of this feature is to modulate the minimum position of the economizer to compensate for varying unit airflows in VAV units, thereby minimizing the large variation of outdoor air CFM that can occur. The feature allows the user to set (calibrate) the economizer minimum position with the VFD at 0 percent and at 100 percent. On units with VFD and economizer, the minimum position of the economizer is modulated based on VFD speed.

Single Zone Variable Air Volume (SZVAV) Only

The IntelliPak™ controls platform will support Single Zone VAV as an optional unit control type in order to meet ASHRAE 90.1. The basic control will be a hybrid VAV/CV configured unit that provides

discharge temperature control to a varying discharge air temperature target setpoint based on the space temperature and/or humidity conditions. Concurrently, the unit will control and optimize the supply fan speed to maintain the zone temperature to a zone temperature setpoint.

Supply Fan Output Control

Units configured for Single Zone VAV control will utilize the same supply fan output control scheme as on traditional VAV units except the VFD signal will be based on zone heating and cooling demand instead of the supply air pressure.

VFD Control

Single Zone VAV units will be equipped with a VFD-controlled supply fan which will be controlled via a 0-10VDC signal from the Rooftop Module (RTM). With the RTM supply fan output energized and the RTM VFD output at 0VDC, the fan speed output is 37% (22Hz) from the VFD by default; and at 10VDC the fan speed output is 100% (60Hz). The control scales the 0-10VDC VFD output from the RTM linearly to control between the 37-100% range. The VFD will modulate the supply fan motor speed, accelerating or decelerating as required to maintain the zone temperature to the zone temperature setpoint. When subjected to high ambient return conditions the VFD will reduce its output frequency to maintain operation. Bypass control is offered to provide full nominal airflow in the event of drive failure.

Ventilation Control

Units configured for Single Zone VAV control will require special handling of the OA Damper Minimum Position control in order to compensate for the non-linearity of airflow associated with the variable supply fan speed and damper combinations. Units configured for Traq™ with or without DCV will operate identically to traditional units with no control changes.

Space Pressure Control

For units configured with Space Pressure Control with or without Statitrac, the new schemes implemented for economizer minimum position handling require changes to the existing Space Pressure Control scheme in order to prevent over/under pressurization. The overall scheme will remain very similar to VAV units with Space Pressure Control with the exception of the dynamic Exhaust Enable Setpoint.

For SZVAV an Exhaust Enable Setpoint must be selected during the 100% Fan Speed Command. Once selected, the difference between the Exhaust Enable Setpoint and Design OA Damper Minimum Position at 100% Fan Speed Command will be calculated. The difference calculated will be used as an offset and added to the Active Building Design OA Minimum Position Target in order to calculate the dynamic Exhaust Enable Target, which will be used throughout the Supply Fan Speed/OA Damper Position range.

The Exhaust Enable Target could be above or below the Active Building Design OA Minimum Position Target Setpoint, based on the Active Exhaust Enable Setpoint being set above or below the Building Design Minimum Position at 100% Fan Speed Command. Note that an Exhaust Enable Setpoint of 0% will result in the same effect on Exhaust Fan control as on VAV applications with and without Statitrac.

Occupied Cooling Operation

For normal cooling operation, cooling capacity will be staged or modulated in order to meet the calculated discharge air target setpoint. If the current active cooling capacity is controlling the discharge air within the deadband, no additional cooling capacity change will be requested. As the Discharge Air Temperature rises above the deadband, the algorithm will request additional capacity as required (additional compressors or economizer). As the Discharge Air Temperature falls below the deadband, the algorithm will request a reduction in active capacity.

Default Economizer Operation

By default, the unit will be setup to optimize the minimum supply fan speed capability during Economizer Only operation. If the economizer is able to meet the demand alone, due to desirable ambient conditions, the supply fan speed will be allowed to increase above the minimum prior to utilizing mechanical cooling if discharge air setpoint falls below the discharge air Lower Limit (Cooling) setpoint

Unoccupied Mode

In Unoccupied mode the unit will utilize setback setpoints, 0% Minimum OA Damper position, and Auto Fan Mode operation as on normal CV units. The Supply Fan speed, and cooling and modulating types of heat, will be controlled to the discharge air target setpoint as is done during occupied periods. The Supply fan speed during staged heat control will be forced to 100% as on normal CV units.

Occupied Heating Operation

Occupied heating operation has two separate control sequences; staged and modulated. All staged heating types will drive the supply fan to maximum flow and stage heating to control to the Zone Heating Setpoint. For units with Hydronic and Gas heat, modulated SZVAV Heating.

On an initial call for heating, the supply fan will drive to the minimum heating airflow. On an additional call for heating, the heat will control in order to meet the calculated discharge air target setpoint. As the load in the zone continues to request heat operation, the supply fan will ramp-up while the control maintains the heating discharge air temperature. Heating can be configured for either the energy saving SZVAV Heating solution as described above, or the traditional, less efficient CV Heating solution.

Compressor (DX) Cooling

Compressor control and protection schemes will function identical to that of a traditional unit. Normal compressor proving and disable input monitoring will remain in effect as well as normal 3-minute minimum on, off, and inter-stage timers. Also, all existing head pressure control schemes will be in effect.

Cooling Sequence

If the control determines that there is a need for active cooling capacity in order to meet the calculated discharge air target setpoint, once supply fan proving has been made, the unit will begin to stage compressors accordingly. Note that the compressor staging order will be based on unit configuration and compressor lead/lag status.

Once the discharge air target setpoint calculation has reached the Minimum Setpoint and compressors are being utilized to meet the demand, as the discharge air target setpoint value continues to calculate lower the algorithm will begin to ramp the supply fan speed up toward 100%. Note that the supply fan speed will remain at the compressor stage's associated minimum value (as described below) until the discharge air target setpoint value is calculated below the discharge air temperature Minimum Setpoint (limited discharge air target setpoint).

As the cooling load in the zone decreases the zone cooling algorithm will reduce the speed of the fan down to minimum per compressor stage and control the compressors accordingly. As the compressors begin to de-energize, the supply fan speed will fall back to the Cooling Stage's associated minimum fan speed, but not below. As the load in the zone continues to drop, cooling capacity will be reduced in order to maintain the discharge air within the $\pm 1/2$ discharge air target deadband.

Constant Volume (CV) Only

Sequence Of Operation

Occupied Zone Temperature Control

Cooling/Economizer

During Occupied cooling mode, the economizer (if provided) and mechanical cooling are used to control zone temperature. If the enthalpy of outside air is appropriate to use "free cooling", the economizer will be used first to attempt to satisfy the cooling zone temperature setpoint; then the compressors will be staged up as necessary. Minimum on/off timing of compressors prevents rapid cycling.

On units with economizer, a call for cooling will modulate the fresh air dampers open. The rate of economizer modulation is based on deviation of the zone temperature from setpoint, i.e., the further away from setpoint, the faster the fresh air damper will open. First stage of cooling will be allowed to start after the economizer reaches full open.

Note that the economizer is only allowed to function freely if one of the following conditions is met: For dry bulb economizer control, the ambient temperature must be below the dry bulb temperature control setting. For reference enthalpy economizer control, outdoor air enthalpy must be below the enthalpy control setting. For comparative enthalpy economizer control, outdoor air enthalpy must be below the enthalpy of the return air.

At outdoor air temperatures above the enthalpy control setting, mechanical cooling only is used and the outdoor air dampers remain at minimum position. If the unit does not include an economizer, mechanical cooling only is used to satisfy cooling requirements. Outdoor air dampers may be set manually for a maximum of 25 percent outdoor air, if rooftop is equipped with 0 to 25 percent manual fresh air damper.

Heating

Gas Heating: Two-Stage

Upon a call for heating, the UCM closes the first stage heating contacts beginning the firing sequence. First, the heat exchanger combustion blower begins operation. Upon positive proving of combustion airflow, a pre-purge cycle is executed. Then the ignition sequence takes place.

If ignition is not proven, the ignition transformer is de-energized. After a time delay another pre-purge cycle takes place followed by another attempt to ignite. If ignition fails a second time, the cycle repeats on 235 and 350 MBh modules. 500, 850 and 1000 MBh modules, the heating section will be shut down and locked out until manually reset at the unit mounted Human Interface Panel.

As additional heat is required, the UCM will close the second stage heating contacts and depending on heat module size, will open either the second stage of the gas valve, or a second stage gas valve.

During heating operation, an electronic flame safety control provides continuous flame supervision. If combustion should become unstable for any reason, heating will automatically shut down. After one minute, another 60 second pre-purge and ignition cycle begins.

As the heating requirement is satisfied, the UCM will open the second stage heating relay, de-energizing the second stage of heat. When the requirement is fully satisfied, the first stage contacts are opened, de-energizing the first stage of heat. The specific sequence of operation of the gas heat will depend on the size of the heat exchanger.

Gas Heating: Modulating Gas

Upon a call for heating, the UCM closes the heating contacts, beginning the firing sequence. First, the heat exchanger combustion blower begins operation. Upon positive proving of combustion airflow, a pre-purge cycle is executed. Then the ignition sequence takes place.

If ignition is not proven, the ignition transformer is de-energized. After a time delay, another pre-purge cycle takes place, followed by another attempt to ignite. If ignition fails a second time, the heating section will be shut down and locked out until manually reset at the unit mounted Human Interface Panel.

As additional heat is required, the air damper opens, increasing the firing rate. During heating operation, an electronic flame safety control provides continuous flame supervision. If combustion should become unstable for any reason, heating will automatically shut down. After one minute, another 60 second pre-purge and ignition cycle begins.

As the heating requirement is satisfied, the UCM will reduce the combustion air, and the firing rate will lower to maintain the desired outlet temperature. When the requirement is fully satisfied, the heating contacts are opened, de-energizing the heat. The specific sequence of operation of the gas heat will depend on the size of the heat exchanger.

Electric Heating

The three stages of electric heat will be sequenced on the zone demand signal from the zone sensor. The signal is sent to the UCM and the stages are sequenced based on load demand.

Hot Water or Steam Heating

Upon a call for heat, the UCM will send a varying voltage signal to the valve actuator. The valve will modulate to meet building demand as indicated by the voltage signal. When heating is satisfied, the valve will modulate closed.

A temperature sensor is located on the coldest section of the coil. When it senses an impending freeze condition, a signal is sent to the hydronic valve to drive it full open. If the supply fan is on, or if the outside air damper is open when this freezing condition is sensed, the supply fan is turned off and the outside air damper is closed.

Auto Changeover

When the System Mode is "Auto" the mode will change to cooling or heating as necessary to satisfy the zone cooling and heating setpoints. The zone cooling and heating setpoints can be as close as 2°F apart.

Unoccupied Zone Temperature Control

Cooling and Heating

Both cooling or heating modes can be selected to maintain Unoccupied zone temperature deadbands. For Unoccupied periods, heating, economizer operation or compressor operation can be selectively locked out at the Human Interface Panels.

CV, SZVAV, and VAV

Note: *SZVAV exceptions are noted in parenthesis*

Space Pressure Control - Statitrac™

A pressure transducer is used to measure and report direct space (building) static pressure. The user-defined control parameters used in this control scheme are space static pressure setpoint and deadband. As the economizer opens, the building pressure rises and enables the exhaust/return fan and dampers or exhaust VFD. The exhaust/return dampers or VFD then modulate to maintain space pressure within the deadband.

Morning Warm-up (Not applicable to SZVAV)

This feature is available on all types of factory-installed heat units and on units with no heat, this function may still be selected to support systems with heat sources not provided by the rooftop unit. At the conclusion of Unoccupied mode, while the economizer (if supplied) is kept closed, the selected zone is heated to the user-defined Morning Warm-up setpoint. The unit is then released to Occupied mode. There are two types of Morning Warm-up: full capacity or cycling capacity.

1. Full Capacity Morning Warm-up (MWU)

Full capacity Morning Warm-up uses full heating capacity, and heats the zone up as quickly as possible. Full heating capacity is provided until the Morning Warm-up setpoint is met. At this point, the unit is released to Daytime mode.

2. Cycling Capacity Morning Warm-up (MWU)

Cycling capacity Morning Warm-up provides a more gradual heating of the zone. Normal zone temperature control with varying capacity is used to raise the zone temperature to the MWU zone temperature setpoint. This method of warm-up is used to overcome the "building sink" effect. Cycling capacity MWU will operate until MWU setpoint is reached or for 60 minutes, then the unit switches to Occupied mode.

Note: *When using the Morning Warmup option in a VAV heating/cooling rooftop, airflow must be maintained through the rooftop unit. This can be accomplished by electrically tying the VAV boxes to the unoccupied output relay contacts on the Rooftop Module (RTM) or by using changeover thermostats. Either of these methods will assure adequate airflow through the unit and satisfactory heating of the building.*

Supply Air Tempering

Hot water, steam, and modulating gas units only - When supply air temperature falls below the supply air temperature deadband low end, the heating valve is modulated open to maintain the set minimum supply air temperature.

Ventilation Override Module (VOM)

The user can customize up to five (5) different override sequences for purposes of ventilation override control. If more than one VOM sequence is being requested, the sequence with the highest priority is initiated first. Sequence hierarchy is the sequence "A" (UNIT OFF) is first, with sequence "E" (PURGE with Duct Pressure Control) last. A ventilation override mode can be initiated by closing any of the five (5) corresponding binary input on the VOM module. A binary output is provided on the VOM module to provide remote indication of an active VOM mode. All compressors, condenser fans and the humidification output are deenergized for any VOM sequence. The factory default definitions for each mode are as follows:

UNIT OFF sequence "A"

When complete system shutdown is required the following sequence can be used.

- Supply Fan - Off
- Supply Fan VFD - Closed/Min (if so equipped)
- Exhaust Fan - Off; Exhaust Dampers - Closed (if so equipped)
- OA Dampers - Closed; Return Damper - Open
- Heat - All heat stages off; Mod Heat output at 0 VDC
- Occupied/Unoccupied/VAV box output - Deenergized
- VOM Relay - Energized
- Preheat Output - Off
- Return Fan - Off; Exhaust Dampers - Closed (if so equipped)
- Return VFD - Min (if so equipped)
- OA Bypass Dampers - Open (if so equipped)
- Exhaust Bypass Dampers - Open (if so equipped)

PRESSURIZE sequence "B"

Perhaps a positively pressurized space is desired instead of a negatively pressurized space. In this case, the supply fan should be turned on with VFD at 100% speed and exhaust fan should be turned off.

- Supply Fan - On
- Supply Fan VFD - Max (if so equipped)

- Exhaust Fan - Off; Exhaust Dampers - Closed (if so equipped)
- OA Dampers - Open; Return Damper - Closed
- Heat - All heat stages off; Mod Heat output at 0 VDC
- Occupied/Unoccupied/VAV box output - Energized
- VOM Relay - Energized
- Preheat Output - Off
- Return Fan - Off; Exhaust Dampers - Closed (if so equipped)
- Return VFD - Min (if so equipped)
- OA Bypass Dampers - Open (if so equipped)
- Exhaust Bypass Dampers - Open (if so equipped)

EXHAUST sequence "C"

With only the exhaust fans running (supply fan off), the space that is conditioned by the rooftop would become negatively pressurized. This is desirable for clearing the area of smoke from the now-extinguished fire, possibly keeping smoke out of areas that were not damaged.

- Supply Fan - Off
- Supply Fan VFD - Closed/Min (if so equipped)
- Exhaust Fan - On; Exhaust Dampers - Open (if so equipped)
- OA Dampers - Closed; Return Damper - Open
- Heat - All heat stages off; Mod Heat output at 0 VDC
- Occupied/Unoccupied/VAV box output - Deenergized
- VOM Relay - Energized
- Preheat Output - Off
- Return Fan - On; Exhaust Dampers - Open (if so equipped)
- Return VFD - Max (if so equipped)
- OA Bypass Dampers - Open (if so equipped)
- Exhaust Bypass Dampers - Open (if so equipped)

PURGE sequence "D"

Possibly this sequence could be used for purging the air out of a building before coming out of Unoccupied mode of operation on VAV units or for the purging of smoke or stale air if required after a fire.

- Supply Fan - On
- Supply Fan VFD - Max (if so equipped)
- Exhaust Fan - On; Exhaust Dampers - Open (if so equipped)
- OA Dampers - Open; Return Damper - Closed
- Heat - All heat stages off; Mod Heat output at 0 VDC
- Occupied/Unoccupied/VAV box output - Energized
- VOM Relay - Energized
- Preheat Output - Off
- Return Fan - On; Exhaust Dampers - Open (if so equipped)
- Return VFD - Max (if so equipped)
- OA Bypass Dampers - Open (if so equipped)
- Exhaust Bypass Dampers - Open (if so equipped)

PURGE with duct pressure control sequence "E"

This sequence can be used when supply air control is required for smoke control.

- Supply Fan - On
- Supply Fan VFD - (If so equipped) Controlled by Supply Air Pressure Control function; Supply Air Pressure High Limit disabled
- Exhaust Fan - On; Exhaust Dampers - Open (if so equipped)
- OA Dampers - Open; Return Damper - Closed

- Heat - All heat stages off; Mod Heat output at 0 VDC
- Occupied/Unoccupied/VAV box output - Energized
- VOM Relay - Energized
- Preheat Output - Off
- Return Fan - On; Exhaust Dampers - Open (if so equipped)
- Return VFD - Max (if so equipped)
- OA Bypass Dampers - Open (if so equipped)
- Exhaust Bypass Dampers - Open (if so equipped)

Emergency Override

When a LonTalk® or BACnet communication module is installed, the user can initiate from the Trane Tracer Summit (in the case of LCI), Tracer SC or 3rd Party BAS (with either BCI or LCI) one of five (5) predefined, not available to configure, Emergency Override sequences. All compressors, condenser fans and the humidification output are deenergized for any Emergency Override sequence. Each Emergency Override sequence commands the unit operation as follows:

EMERG_PRESSURIZE:

- Supply Fan - On
- Supply Fan VFD - Open/Max (if so equipped)
- Exhaust Fan - Off; Exhaust Dampers - Closed (if so equipped)
- OA Dampers - Open; Return Damper - Closed
- Heat - All heat stages off; Mod Heat output at 0 VDC
- Occupied/Unoccupied/VAV box output - Energized
- VOM Relay - Energized (if so equipped)
- Preheat Output - Off
- Return Fan - Off; Exhaust Dampers - Closed (if so equipped)
- Return VFD - Min (if so equipped)

EMERG_DEPRESSURIZE:

- Supply Fan - Off
- Supply Fan VFD - Closed/Min (if so equipped)
- Exhaust Fan - On; Exhaust Dampers - Open/Max (if so equipped)
- OA Dampers - Closed; Return Damper - Open
- Heat - All heat stages off; Mod Heat output at 0 VDC
- Occupied/Unoccupied/VAV box output - Energized
- VOM Relay - Energized (if so equipped)
- Preheat Output - Off
- Return Fan - On; Exhaust Dampers - Open (if so equipped)
- Return VFD - Max (if so equipped)

EMERG_PURGE:

- Supply Fan - On
- Supply Fan VFD - Open/Max (if so equipped)
- Exhaust Fan - On; Exhaust Dampers - Open (if so equipped)
- OA Dampers - Open; Return Damper - Closed
- Heat - All heat stages off; Mod Heat output at 0 VDC
- Occupied/Unoccupied/VAV box output - Energized
- VOM Relay - Energized (if so equipped)
- Preheat Output - Off
- Return Fan - On; Exhaust Dampers - Open (if so equipped)
- Return VFD - Max (if so equipped)

EMERG_SHUTDOWN:

- Supply Fan - Off
- Supply Fan VFD - Closed/Min (if so equipped)
- Exhaust Fan - Off; Exhaust Dampers Closed (if so equipped)
- OA Dampers - Closed; Return Damper - Open
- Heat - All heat stages off; Mod Heat output at 0 VDC
- Occupied/Unoccupied/VAV box output - Energized
- VOM Relay - Energized (if so equipped)
- Preheat Output - Off
- Return Fan - Off; Exhaust Dampers - Closed (if so equipped)
- Return VFD - Min (if so equipped)

EMERG_FIRE - Input from fire pull box/system:

- Supply Fan - Off
- Supply Fan VFD - Closed/Min (if so equipped)
- Exhaust Fan - Off; Exhaust Dampers Closed (if so equipped)
- OA Dampers - Closed; Return Damper - Open
- Heat - All heat stages off; Mod Heat output at 0 VDC
- Occupied/Unoccupied/VAV box output - Energized
- VOM Relay - Energized (if so equipped)
- Preheat Output - Off
- Return Fan - Off; Exhaust Dampers - Closed (if so equipped)
- Return VFD - Min (if so equipped)

Human Interface Panel (HI)

The Human Interface (HI) Panel provides a 2 line X 40 character clear English liquid crystal display and a 16 button keypad for monitoring, setting, editing and controlling. The Human Interface Panel is mounted in the unit's main control panel and is accessible through a hatch built into the unit's control panel door.

The optional remote-mount version of the Human Interface (RHI) Panel has all the functions of the unit-mount version except Service Mode. To use a RHI the unit must be equipped with an optional InterProcessor Communications Bridge (IPCB). The RHI can be located up to 1,000 feet from the unit. A single RHI can be used to monitor and control up to 4 rooftops, each containing an IPCB.

Human Interface Panel Main Menu

- STATUS - used to monitor all temperatures, pressures, humidities, setpoints, input and output status. The
- CUSTOM key allows the user to customize a status report-consisting of up to (4) screens of the data available in the main Status menu.
- SET POINTS - used to edit all factory preset Default setpoints
- DIAGNOSTICS - used to review active and historical lists of diagnostic conditions. A total of 49 different diagnostics can be read at the Human Interface Panel. The last 20 diagnostics can be held in an active history buffer log.
- SETUP - Control parameters, sensor selections, setpoint source selections, output definitions, and numerous other points can be edited in this menu. All points have factory preset values so unnecessary editing is kept to a minimum.
- CONFIGURATION - Preset with the proper configuration for the unit as it ships from the factory, this information would be edited only if certain features were physically added or deleted from the unit. For example, if a field supplied Trane Communication Interface (TCI) module or Ventilation Override Module was added to the unit in the field, the unit configuration would need to be edited to reflect that feature.

- **SERVICE** - used to selectively control outputs (for compressors, fans, damper position, etc.) for servicing or troubleshooting the unit. This menu is accessible only at the unit-mounted Human Interface Panel.

Generic Building Automation System Module (GBAS)

Generic Building Automation System Module (GBAS 0-5 VDC)

The Generic Building Automation System Module (GBAS 0-5 VDC) available on IntelliPak™ 20-75 ton air-cooled/24-89 ton evaporative condensing is used to provide broad control capabilities for building automation systems other than Trane's Tracer system. The following inputs and outputs are provided:

Analog Inputs - Four analog inputs, controlled via a field provided potentiometer or a 0-5 VDC signal, that can be configured to be any of the following:

1. Occupied Zone Cooling Setpoint (CV & SZVAV)
2. Unoccupied Zone Cooling Setpoint
3. Occupied Zone Heating Setpoint
4. Unoccupied Zone Heating Setpoint (SZ)
5. Supply Air Cooling Setpoint (CV, SZVAV& VAV with Discharge Temperature Control only)
6. Supply Air Heating Setpoint (CV, SZVAV& VAV with Discharge Temperature Control only)
7. Space Static Pressure Setpoint
8. Supply Air Static Pressure Setpoint (CV & VAV)
9. Minimum Outside Air Flow Setpoint
10. Morning Warm Up Setpoint (CV & VAV)
11. Economizer Dry Bulb Enable Setpoint
12. Minimum Outside Air Position Setpoint
13. Occupied Humidification Setpoint
14. Unoccupied Humidification Setpoint

Binary Outputs - each of the five (5) relay outputs can be mapped to any/all of the available diagnostics.

Binary Input - the single binary input can initiate or terminate the Demand Limit mode of operation via a field supplied switch or contact closure.

Demand Limiting Binary Input - this function is operational on units with a GBAS and is used to reduce electrical consumption at peak load times. There are two types of demand limiting, 50% and 100%. When demand limiting is needed, mechanical cooling and heating operation are either partially (50%), or completely disabled (100%), in order to save energy. The definition of Demand Limit is user definable at the Human Interface Panel. Demand Limit binary input accepts a field supplied switch or contact closure. When the need for demand limiting has been discontinued, the unit cooling/heating functions will again become fully enabled.

Generic Building Automation System Module (GBAS 0-10 VDC)

The Generic Building Automation System Module (GBAS 0-10 VDC) is used to provide broad control capabilities for building automation systems other than Trane's Tracer system. The following inputs and outputs are provided:

Analog Inputs—Four analog inputs, controlled via a field provided potentiometer or a 0-10 VDC signal, that can be configured to be any of the following:

1. Occupied Zone Cooling Setpoint (CV & SZVAV)
2. Unoccupied Zone Cooling Setpoint
3. Occupied Zone Heating Setpoint

4. Unoccupied Zone Heating Setpoint
5. Supply Air Cooling Setpoint (CV, SZVAV & VAV with Discharge Temperature Control)
6. Supply Air Heating Setpoint (CV, SZVAV & VAV with Discharge Temperature Control)
7. Space Static Pressure Setpoint
8. Supply Air Static Pressure Setpoint (CV & VAV)
9. Minimum Outside Air Flow Setpoint
10. Morning Warm Up Setpoint (CV & VAV)
11. Economizer Dry Bulb Enable Setpoint
12. Minimum Outside Air Position Setpoint
13. Occupied Humidification Setpoint
14. Unoccupied Humidification Setpoint

Analog Outputs—Four analog outputs that can be configured to be any of the following:

1. Outdoor Air Temperature
2. Zone Temperature
3. Supply Air Temperature (CV, SZVAV & VAV with Discharge Temperature Control)
4. Supply Air Pressure (SZVAV & VAV)
5. Space Pressure
6. Space Relative Humidity
7. Outdoor Air Relative Humidity
8. Space CO₂ Level
9. Compressor Staging (%)
10. Heat Staging (%)
11. Outdoor Air Damper Position
12. Outdoor Airflow
13. Occupied Humidification Setpoint
14. Unoccupied Humidification Setpoint

Binary Output - the single relay output can be mapped to any/all of the available diagnostics.

Binary Input - the single binary input can initiate or terminate the Demand Limit mode of operation, via a field supplied switch or contact closure.

Demand Limiting Binary Input - this function is operational on units with a GBAS and is used to reduce electrical consumption at peak load times. There are two types of demand limiting, 50% and 100%. When demand limiting is needed, mechanical cooling and heating operation are either partially (50%), or completely disabled (100%), in order to save energy. The definition of Demand Limit is user definable at the Human Interface Panel. Demand Limit binary input accepts a field supplied switch or contact closure. When the need for demand limiting has been discontinued, the unit cooling/heating functions will again become fully enabled.

Frost Avoidance

Steam and Hot Water Coil - Freeze Avoidance

Freeze Avoidance is a feature which helps prevent freezing of steam or hot water heat coils during periods of unit inactivity and low ambient temperatures. Whenever the unit supply fan is off, the outdoor air temperature is monitored. If the temperature falls below a predetermined value, the

heating valve is opened to a position selected at the unit mounted Human Interface to allow a minimum amount of steam or hot water to flow through the coil and avoid freezing conditions.

Evaporator Coil Frost Protection - Frostat™

A temperature sensor on the evaporator is used to determine if the coil is getting close to a freezing condition. Mechanical cooling capacity is shed as necessary to prevent icing.

The Frostat™ system eliminates the need for hot gas bypass and adds a suction line surface temperature sensor near the TXV bulb location to shut the cooling off when coil frosting conditions occur. The supply fans are not shut off and will de-ice the coil. Timers prevent the compressors from rapid cycling.

Occupied/Unoccupied Switching

a. Description - 3 ways to switch Occupied/Unoccupied:

- (1) NSB Panel
- (2) Field-supplied contact closure (hardwired binary input to RTM)
- (3) Tracer™ (or 3rd Party BAS with LCI or BCI module)

Trane Tracer or BAS System

The Trane Tracer System or a 3rd party BAS (with LCI or BCI module) can control the Occupied/Unoccupied status of the rooftop.

Night Setback Sensors

Trane's night setback sensors are programmable with a time clock function that provides communication to the rooftop unit through a 2-wire communications link. The desired transition times are programmed at the night setback sensor and communicated to the rooftop.

Night setback (unoccupied mode) is operated through the time clock provided in the sensors with night setback. When the time clock switches to night setback operation, the outdoor air dampers close and heating/cooling can be enabled or disabled depending on set-up parameters. As the building load changes, the night setback sensor energizes the rooftop heating/cooling (if enabled) function and the evaporator fan. The rooftop unit will cycle through the evening as heating/cooling (if enabled) is required in the space. When the time clock switches from night setback to occupied mode, all heating/cooling functions begin normal operation.

When using the night setback options with a VAV heating/cooling rooftop, airflow must be maintained through the rooftop unit. This can be accomplished by electrically tying the VAV boxes to the Unoccupied output relay contacts on the Rooftop Module (RTM) or by using changeover thermostats. Either of these methods will assure adequate airflow through the unit and satisfactory temperature control of the building.

Timed Override Activation - ICS

This function is operational when the RTM is the zone temperature sensor source, which was set up at the Human Interface Panel. When this function is initiated by the push of an override button on the ICS sensor, the Tracer will switch the unit to the Occupied mode. Unit operation (Occupied mode) during timed override is terminated by a signal from Tracer.

Timed Override Activation - Non-ICS

This function is active whenever the RTM is selected as the Zone Temperature Sensor source, which was set up at the Human Interface Panel. When this function is initiated by the push of an override button on the zone sensor, the unit will switch to the Occupied mode. Automatic Cancellation of the Timed Override Mode occurs after three hours of operation.

Low Ambient Compressor Lockout

This function will lock out the compressor if the outdoor air temperature is below the low ambient compressor lock out temperature set point. The factory setpoint is 50°F on standard units and 0°F on low ambient units. This setpoint is adjustable at the Human Interface Panel. Compressors will be locked out when outdoor air temperatures falls below that selected temperature and will be allowed to start again when the temperature rises 5°F above the setpoint.

Outdoor Air Damper Fault Detection and Diagnostics

Fault Detection of the Outdoor Air Damper will be evaluated based on the commanded position of the damper compared to the feedback position of the damper. The damper is commanded to a position based on a 0-10 / 2-10 VDC signal. If the Damper position is outside of the commanded position, a diagnostic is generated. The new Diagnostics can be placed into two groups, Economizer and Outdoor Air Damper. To be classified as an Economizer diagnostic, the unit must be actively cooling with either mechanical cooling and or Economizer cooling. The following are the Diagnostics displayed by the Controller: Unit Not Economizing when it should be, Unit Economizing when it should not be, Outdoor Air Damper Not Modulating, Excessive Outdoor Air.

Comparative Enthalpy Control of Economizer

An optional Comparative Enthalpy system is used to control the operation of the economizer, and measures the temperature and humidity of both return air and outside air to determine which source has lower enthalpy. This system allows true comparison of outdoor air and return air enthalpy by measurement of outdoor air and return air temperatures and humidities.

Reference Enthalpy Control of Economizer

The optional reference enthalpy compares ambient temperature and humidity to the economizer enthalpy control setpoint. If ambient temperature and humidity are below the economizer enthalpy control setpoint the economizer will operate freely. This system provides more sophisticated control where outdoor air humidity levels may not be acceptable for building comfort and indoor air quality.

Dry Bulb Temperature Control of Economizer

The optional dry bulb system measures ambient temperature comparing it to the economizer control temperature setpoint. If the ambient temperature is below the economizer dry bulb temperature control setpoint, the economizer will operate freely. This system is best suited for arid regions where the humidity levels of outside air would not be detrimental to building comfort and indoor air quality.

Compressor Lead/Lag

Compressor lead/lag is always set as enabled on all units. After each request for compressor operation, the lead refrigeration circuit or compressor on 20-30 tons units switches, thereby causing a more equitable or balanced run time among compressors. Lead/lag is not available on units with hot gas bypass or units with variable speed compressors.

Emergency Stop Input

A binary input is provided on the Rooftop Module (RTM) for installation of field provided switch or contacts for immediate shutdown of all unit functions.

Humidification Control

A relay output is provided to control an externally connected, field supplied humidifier. Logic is provided for Occupied and Unoccupied humidification control with safeguards to prevent cycling between humidification and dehumidification.

Hot Gas Reheat (Modulating Dehumidification) - Available on S_HL IntelliPaks

When space conditions allow, the modulating dehumidification function activates the reheat mode providing dehumidification of the space. The reheat valve and cooling valve are modulated to control the discharge air temperature to the discharge air temperature reheat setpoint (default 70°F). In reheat mode, the reheat valve is commanded (15 to 85%) to control to the discharge air reheat setpoint and the cooling valve mirrors the reheat valve position (85 to 15%).

Hot Gas Bypass Control

A hot gas bypass valve is installed on circuit 2. The valve modulates hot gas to the inlet of the evaporator when suction pressure falls below valve adjustable setpoint. This feature allows operation at low airflow, while avoiding coil frosting and damage to the compressors.

Return Fan Control

A return fan reduces the load on the supply fan motor or can allow a unit to operate at a higher static pressure. The return fan VFD is modulated independently to maintain desired return air plenum pressure. In all other cases the return fan is turned on or off with the supply fan.

Low Charge Protection

The low charge feature measures the entering and leaving evaporator temperatures on each circuit to calculate a superheat value for each circuit. The superheat value is used for multiple purposes:

- Displayed at the Human Interface panel to assist the service technician with unit charging and diagnostics
- A diagnostic message displayed at the Human Interface panel, warning of a low charge situation when the unit is just slightly undercharged. The unit will be allowed to run.
- A diagnostic message displayed at the Human Interface panel, warning of a low charge situation when the unit is undercharged. The undercharged circuit will be locked out to protect the compressors.

LonTalk® Building Automation System

The LonTalk® Communication Interface for IntelliPak™ (LCI-I) controller expands communications from the unit UCM network to a Trane Tracer Summit or a 3rd party building automation system, utilizing LonTalk®, and allows external setpoint and configuration adjustment and monitoring of status and diagnostics. The LCI-I utilizes an FTT-10A Free Topology transceiver, which supports non-polarity sensitive, free topology wiring, which allows the system installer to utilize star, bus, and loop architectures. This controller works in standalone mode, peer-to-peer with one or more other units, or when connected to a Trane Tracer Summit or a 3rd party building automation system that supports LonTalk®. The LCI-I controller is available as a factory or field-installed kit.

BACnet Building Automation System

The BACnet Communication Interface for IntelliPak™ (BCI-I) controller expands communications from the unit UCM network to Tracer SC or a 3rd party building automation system, utilizing BACnet, and allows external setpoint and configuration adjustment and monitoring of status and diagnostics. The BCI-I utilizes the BACnet defined MS/TP protocol as defined in ASHRAE standard 135-2004. This controller works in standalone mode, with Tracer SC or when connected to a 3rd party building automation system that supports BACnet. The BCI-I controller is available as a factory or field-installed kit.

CO₂ Demand Control Ventilation

CO₂ Demand Control Ventilation (DCV) provides ventilation for occupants while reducing energy consumption. It does so by minimizing the OA damper position (units without Traq™) or the OA flow setpoint (units with Traq™), below the Building Design Minimum, per ASHRAE Std 62.1-2004. If the space CO₂ level is below the CO₂ Minimum Setpoint the OA damper shall close to the DCV Minimum OA Damper Setpoint (units without Traq™) or until the DCV Minimum OA flow Setpoint is met (units with Traq™.)

Electrical Data

Electrical Service Sizing

To correctly size electrical service wiring for your unit, find the appropriate calculations listed below. Each type of unit has its own set of calculations for MCA (Minimum Circuit Ampacity), MOP (Maximum Overcurrent Protection), and RDE (Recommended Dual Element fuse size). Read the load definitions that follow and then find the appropriate set of calculations based on your unit type. Set 1 is for cooling only and cooling with gas heat units, and set 2 is for cooling with electric heat units.

Load Definitions: (To determine load values, see the Electrical Service Sizing Data Tables on the following page.)

LOAD1 = CURRENT OF THE LARGEST MOTOR (COMPRESSOR OR FAN MOTOR)

LOAD2 = SUM OF THE CURRENTS OF ALL REMAINING MOTORS

LOAD3 = CURRENT OF ELECTRIC HEATERS

LOAD4 = ANY OTHER LOAD RATED AT 1 AMP OR MORE

Set 1. Cooling Only Rooftop Units and Cooling with Gas Heat Rooftop Units

$$\text{MCA} = (1.25 \times \text{LOAD1}) + \text{LOAD2} + \text{LOAD4}$$

$$\text{MOP} = (2.25 \times \text{LOAD1}) + \text{LOAD2} + \text{LOAD4}$$

Select a fuse rating equal to the MOP value. If the MOP value does not equal a standard fuse size as listed in NEC 240-6, select the next lower standard fuse rating.

Note: *If selected MOP is less than the MCA, then reselect the lowest standard maximum fuse size which is equal to or larger than the MCA, provided the reselected fuse size does not exceed 800 amps.*

$$\text{RDE} = (1.5 \times \text{LOAD1}) + \text{LOAD2} + \text{LOAD4}$$

Select a fuse rating equal to the RDE value. If the RDE value does not equal a standard fuse size as listed in NEC 240-6, select the next higher standard fuse rating.

Note: *If the selected RDE is greater than the selected MOP value, then reselect the RDE value to equal the MOP value.*

Set 2. Rooftop units with Electric Heat

b. Single Source Power (380V, 415V, 460V, and 575V)

To arrive at the correct MCA, MOP, and RDE values for these units, you must perform two sets of calculations. First calculate the MCA, MOP, and RDE values as if the unit was in cooling mode (use the equations given in Set 1). Then calculate the MCA, MOP, and RDE values as if the unit were in the heating mode as follows.

(Keep in mind when determining LOADS that the compressors don't run while the unit is in the heating mode).

For units using heaters less than 50 kW.

$$\text{MCA} = 1.25 \times (\text{LOAD1} + \text{LOAD2} + \text{LOAD4}) + (1.25 \times \text{LOAD3})$$

For units using heaters equal to or greater than 50 kW.

$$\text{MCA} = 1.25 \times (\text{LOAD1} + \text{LOAD2} + \text{LOAD4}) + \text{LOAD3}$$

The nameplate MCA value will be the larger of the cooling mode MCA value or the heating mode MCA value calculated above.

$$\text{MOP} = (2.25 \times \text{LOAD1}) + \text{LOAD2} + \text{LOAD3} + \text{LOAD4}$$

The selection MOP value will be the larger of the cooling mode MOP value or the heating mode MOP value calculated above.

Select a fuse rating equal to the MOP value. If the MOP value does not equal a standard fuse size as listed in NEC 240-6, select the next lower standard fuse rating.

Note: If selected MOP is less than the MCA, then reselect the lowest standard maximum fuse size which is equal to or larger than the MCA, provided the reselected fuse size does not exceed 800 amps.

$$RDE = (1.5 \times \text{LOAD1}) + \text{LOAD2} + \text{LOAD3} + \text{LOAD4}$$

The selection RDE value will be the larger of the cooling mode RDE value or the heating mode RDE value calculated above.

Select a fuse rating equal to the RDE value. If the RDE value does not equal a standard fuse size as listed in NEC 240-6, select the next higher standard fuse rating.

Note: If the selected RDE is greater than the selected MOP value, then reselect the RDE value to equal the MOP value.

b. Dual Source Power units (200V and 230V)

These units will have two circuit values shown on the nameplate. The first circuit value will be the refrigeration (cooling mode) values calculated per Set 1. The second set of circuit values shown on the nameplate will be for the electric heating circuit as follows.

$$MCA = (1.25 \times \text{LOAD3})$$

$$MOP = (1.25 \times \text{LOAD3})$$

Select a fuse rating for the electric heating circuit that's equal to the MOP value obtained in the equation above. If the MOP value does not equal a standard fuse size as listed in NEC 240-6, select the next lower standard fuse rating (see note below for exception).

Note: If the available MOP option is less than the MCA obtained in the equation above, then reselect the lowest standard maximum fuse size which is equal to, or larger, than the MCA, provided the reselected fuse size does not exceed 800 amps.

$$RDE = \text{LOAD3}$$

Select a fuse rating for the electric heating circuit that's equal to the RDE value. If the RDE value does not equal a standard fuse size as listed in NEC 240-6, select the next higher standard fuse rating.

Notes:

1. If the selected RDE is greater than the selected MOP value, then reselect the RDE value to equal the MOP value.
2. The selected MOP value is stamped in the MOP field on the nameplate.

Table 71. Compressor electrical service sizing data (20-130 ton)

Tonnage	No. of Compressors	200V		230V		460V		575V	
		RLA	LRA	RLA	LRA	RLA	LRA	RLA	LRA
20 Std	2	41.4	267.0	40.3	267.0	19.1	142.0	15.8	103.0
20 Hi Eff	2	41.4	267.0	40.3	267.0	19.1	142.0	15.8	103.0
25 Std	1	41.4	267.0	40.3	267.0	19.1	142.0	15.8	103.0
	1	47.0	304.0	41.0	304.0	20.2	147.0	17.1	122.0
25 Hi Eff	1	41.4	267.0	40.3	267.0	19.1	142.0	15.8	103.0
	1	51.9	315.0	47.0	315.0	22.2	158.0	19.2	136.0
30 Std	2	51.9	315.0	47.0	315.0	22.2	158.0	19.2	136.0
30 Hi Eff	1	51.9	315.0	47.0	315.0	22.2	158.0	19.2	136.0
	1	56.9	351.0	48.8	351.0	25.5	197.0	23.1	135.0
40 Std	2	31.3	203.0	30.4	203.0	13.1	98.0	11.9	84.0
	2	37.3	267.0	31.8	267.0	15.9	142.0	15.2	103.0
40 Hi Eff	4	37.3	267.0	31.8	267.0	15.9	142.0	15.2	103.0

Electrical Data

Table 71. Compressor electrical service sizing data (20-130 ton) (continued)

Tonnage	No. of Compressors	200V		230V		460V		575V	
		RLA	LRA	RLA	LRA	RLA	LRA	RLA	LRA
40 Vari Spd	1 ^(a)	59.9	N/A	52.0	N/A	26.0	N/A	21.7	N/A
	1	31.3	203.0	30.4	203.0	13.1	98.0	11.9	84.0
	1	37.3	267.0	31.8	267.0	15.9	142.0	15.2	103.0
50 Std	4	41.4	267.0	40.3	267.0	19.1	142.0	15.8	103.0
50 Hi Cap & Hi Eff	2	41.4	267.0	40.3	267.0	19.1	142.0	15.8	103.0
	2	47.0	304.0	42.3	304.0	20.2	147.0	17.1	122.0
50 Vari Spd	1 ^(a)	75.2	N/A	65.2	N/A	32.6	N/A	27.5	N/A
	1	41.4	267.0	40.3	267.0	19.1	142.0	15.8	103.0
	1	47.0	304.0	42.3	304.0	20.2	147.0	17.1	122.0
55 Std & Hi Eff	4	47.0	304.0	42.3	304.0	20.2	147.0	17.1	122.0
55 Vari Spd	1 ^(a)	75.2	N/A	65.2	N/A	32.6	N/A	27.5	N/A
	1	47.0	304.0	42.3	304.0	20.2	147.0	17.1	122.0
	1	51.9	315.0	47.0	315.0	22.2	158.0	19.2	136.0
60 Std	2	47.0	304.0	42.3	304.0	20.2	147.0	17.1	122.0
	2	51.9	315.0	47.0	315.0	22.2	158.0	19.2	136.0
60 Hi Cap & Hi Eff	4	51.9	315.0	47.0	315.0	22.2	158.0	19.2	136.0
60 Vari Spd	1 ^(a)	89.9	N/A	77.9	N/A	38.9	N/A	32.7	N/A
	1	51.9	315.0	47.0	315.0	22.2	158.0	19.2	136.0
	1	56.9	351.0	48.8	351.0	25.5	197.0	23.1	146.0
70 Std & Hi Eff	4	56.9	351.0	48.8	351.0	25.5	197.0	23.1	146.0
70 Vari Spd	1 ^(a)	89.9	N/A	77.9	N/A	38.9	N/A	32.7	N/A
	1	60.5	320.0	52.0	320.0	25.4	160.0	20.3	135.0
	1	83.9	485.0	74.5	485.0	37.2	215.0	29.8	175.0
75 Std	2	60.5	320.0	52.0	320.0	25.4	160.0	20.3	135.0
	2	83.9	485.0	74.5	485.0	37.2	215.0	29.8	175.0
75 Hi Cap & Hi Eff	2	60.5	320.0	52.0	320.0	25.4	160.0	20.3	135.0
	2	83.9	485.0	74.5	485.0	37.2	215.0	29.8	175.0
90 Std & Hi Cap	4	N/A	N/A	N/A	N/A	37.2	215.0	29.8	175.0
105 Hi Cap	2	N/A	N/A	N/A	N/A	37.2	215.0	29.8	175.0
	2	N/A	N/A	N/A	N/A	45.0	260.0	36.0	210.0
115 Std	2	N/A	N/A	N/A	N/A	37.2	215.0	29.8	175.0
	2	N/A	N/A	N/A	N/A	45.0	260.0	36.0	210.0
130 Std	4	N/A	N/A	N/A	N/A	45.0	260.0	36.0	210.0

(a) Variable Speed Compressor

Table 72. Electrical service sizing data – motors – 20-130 tons

Nominal Tons	Nominal Voltage			
	200 FLA	230 FLA	460 FLA	575 FLA
	Air-Cooled Condenser Fan Motor			
20	8.2	8.2	3.6	2.8
25	12.3	12.3	5.4	4.2
30	12.3	12.3	5.4	4.2
40	16.4	16.4	7.2	5.6
50, 55	24.6	24.6	10.8	8.4
60	24.6	24.6	10.8	8.4
70	24.6	24.6	10.8	8.4
75	24.6	24.6	10.8	8.4
90	N/A	N/A	14.4	11.2
105	N/A	N/A	18.0	14.0
115	N/A	N/A	18.0	14.0
130	N/A	N/A	21.6	16.8
Motor Horsepower	Supply ^(a) /Exhaust/Return Fan Motor ^(b) (4 pole)			
3	11.0	8.6	4.3	3.8
5	15.3	13.2	6.6	5.4
7.5	22.2	18.8	9.4	7.8
10	29.5	25.2	12.6	10.1
15	40.7	35.4	17.7	15.1
20	56.1	49.4	24.7	19.6
25	70.5	62.0	31.0	24.5
30	85.5	73.2	36.6	29.2
40 ^(c)	N/A	N/A	49.0	39.0
50 ^(c)	N/A	N/A	60.5	48.0
Motor Horsepower	Supply Fan Motor (6 pole) ^{(a)(d)}			
3	10.1	8.8	4.4	3.7
5	17.0	14.8	7.4	5.8
7.5	25.0	22.0	11.0	8.6
10	32.0	28.6	14.3	11.5
15	46.0	41.0	20.5	16.0
20	63.0	54.0	27.0	22.0

(a) FLA is for individual motors by HP, not total unit supply fan HP.

(b) Return fan motors are available in 3-20 Hp

(c) 40 & 50 Hp motor available as standard in 460 & 575 volt only

(d) DDP fans selected under 1,600 RPM will have 6-pole motors

Table 73. Electrical service sizing data –electric heat module (electric heat units only) – 20-130 tons

Module kW	Voltage			
	200 FLA	230 FLA	460 FLA	575 FLA
30	83.3	72.2	36.1	28.9
50	138.8	120.3	60.1	48.1
70	194.3	168.4	84.2	67.4

Table 73. Electrical service sizing data – electric heat module (electric heat units only) – 20-130 tons (continued)

90	249.8	216.5	108.3	86.6
110	305.3	264.6	132.3	105.9
130			156.4	125.1
150			180.4	144.3
170			204.5	163.6
190			228.5	182.8

Note: Electric heat FLA are determined at 208, 240, 480 and 600 volts.

Table 74. Electrical service sizing data – control power transformer heating and cooling modes – 20-130 tons

Nominal Tons (AC/EC)	Digit 2 Unit Function	Voltage			
		200	230	460	575
20,25,30	A,E,L,S,X	1	1	1	1
	F	4	3	2	1
40,50,55,60	A,E,L,S,X	3	2	1	1
	F	5	4	2	2
70,75	A,E,L,S,X	5	4	2	2
	F	8	7	3	3
90,105,115,130	E,L,S,X	5	4	2	2
	F	8	7	3	3

Table 75. Electrical service sizing data – crankcase heaters (heating mode on 460/575 volt only) – 20-130 tons

Nominal Tons (AC/EC)	(Add) FLA
20,25,30	1
40,50,55,60	2
70,75	3
90-105	3
115-130	4

Table 76. Voltage utilization range

Unit Voltage	Voltage Utilization Range
200/60/3	180-220
230/60/3	207-253
380/50/3	342-418
415/50/3	373-457
460/60/3	414-506
575/60/3	517-633

Dimensional Data

Figure 28. Cooling only unit dimensions - SAHL – 20-75 ton air-cooled

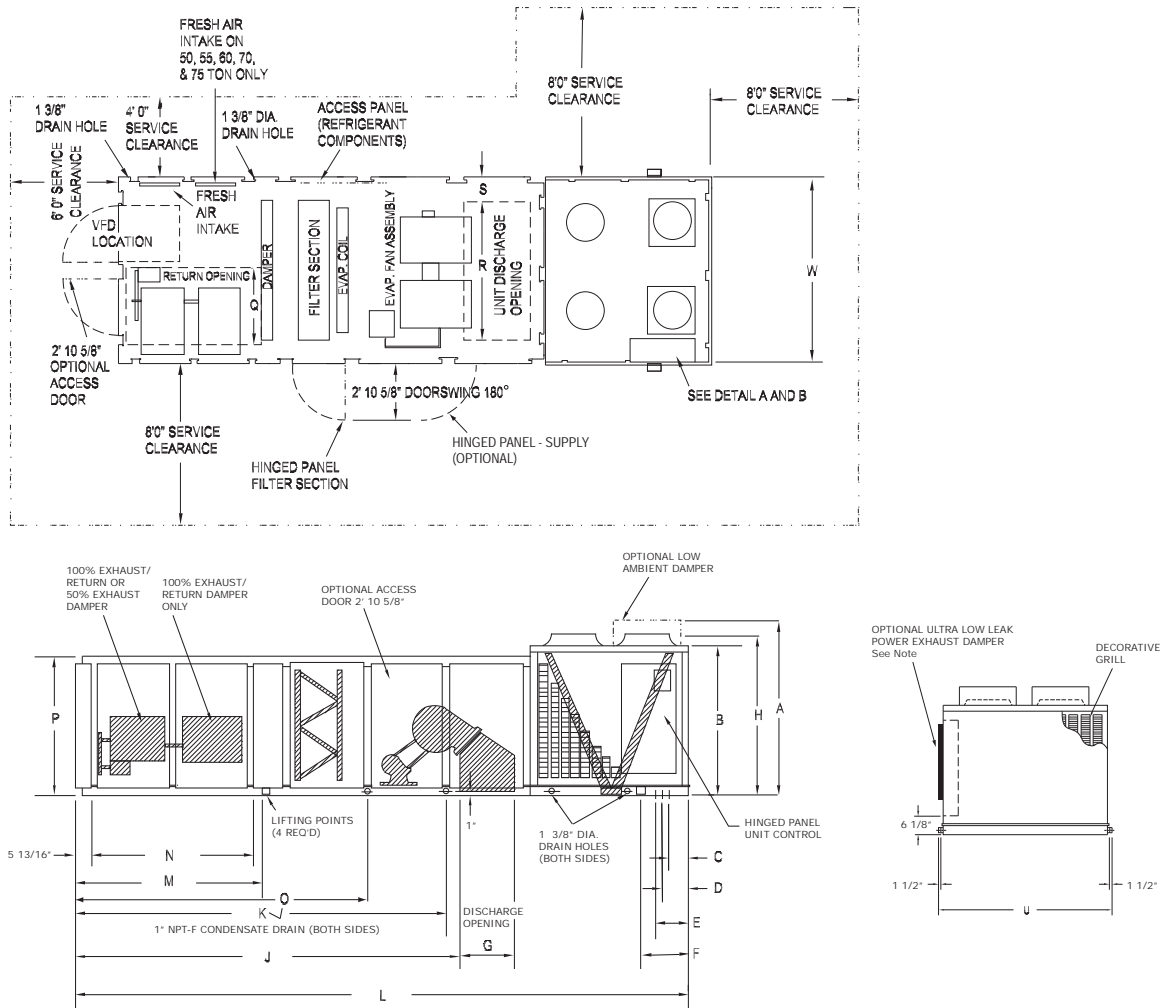

Table 77. Cooling only unit dimensions (ft. in.) - SAHL

Nom. Tons	H	L	W	A	B	C	D	E	F	G	J
20 & 25	7-3 1/4	21-9 3/4	7-6 1/2	7-10 5/8	6-9	0-9 1/2	1-3 5/8	1-7 9/16	1-3 1/2	2-2 1/2	14-0 1/4
30	7-3 1/4	21-9 3/4	7-6 1/2	7-10 5/8	6-9	0-9 1/2	1-3 5/8	1-7 9/16	1-3 1/2	2-2 1/2	14-0 1/4
40	7-3 1/4	29-8	7-6 1/2	7-10 5/8	6-9	0-9 7/8	1-5 7/8	1-10 1/8	2-5	2-5	16-7 13/16
50 & 55	7-3 1/4	29-8	7-6 1/2	7-10 5/8	6-9	0-9 1/2	1-3 5/8	1-7 9/16	2-5	2-5	16-7 13/16
60	7-3 1/4	29-8	9-8	7-10 5/8	6-9	0-9 7/8	1-5 7/8	1-10 1/8	2-5	2-5	16-7 13/16
70 & 75	7-3 1/4	29-8	9-8	7-10 5/8	6-9	0-9 7/8	1-5 7/8	1-10 1/8	2-5	2-5	16-7 13/16
Nom. Tons	K	M	N		O	P	Q		R	S	U
			w/exhaust fan	w/return fan			w/exhaust fan	w/return fan			
20 & 25	12-6	7-0	6-6 15/16	3	10-7	3-9 5/16	3-4 3/8	2 - 9 15/16	5-7	0-11 3/4	7-9 1/2
30	12-6	7-0	6-6 15/16	3	10-7	4-9 5/16	3-4 3/8	2 - 9 15/16	5-7	0-11 3/4	7-9 1/2
40	15-11 1/8	8-0	7-8 3/16	3 - 4	12-1	5-9 5/16	3-4 3/8	3 - 1 1/2"	5-7	0-11 3/4	7-9 1/2
50 & 55	15-11 1/8	8-0	7-8 3/16	3 - 4	12-1	6-9 3/8	3-4 3/8	3 - 1 1/2"	5-7	0-11 3/4	7-9 1/2
60	15-11 1/8	8-0	7-8 3/16	4 - 5	12-1	5-9 5/16	4-5 3/8	4 - 2 1/2"	6-10 7/8	1-4 9/16	9-11
70 & 75	15-11 1/8	8-0	7-8 3/16	4 - 5	12-1	5-9 5/16	4-5 3/8	4 - 2 1/2"	6-10 7/8	1-4 9/16	9-11

Note: Optional Ultra Low Leak Power Exhaust extends beyond lifting lug and increases overall "U" and "Z" dimension by 0.65".

Dimensional Data

Figure 29. Heating/cooling unit dimensions⁽¹⁾ – 20-75 ton air-cooled

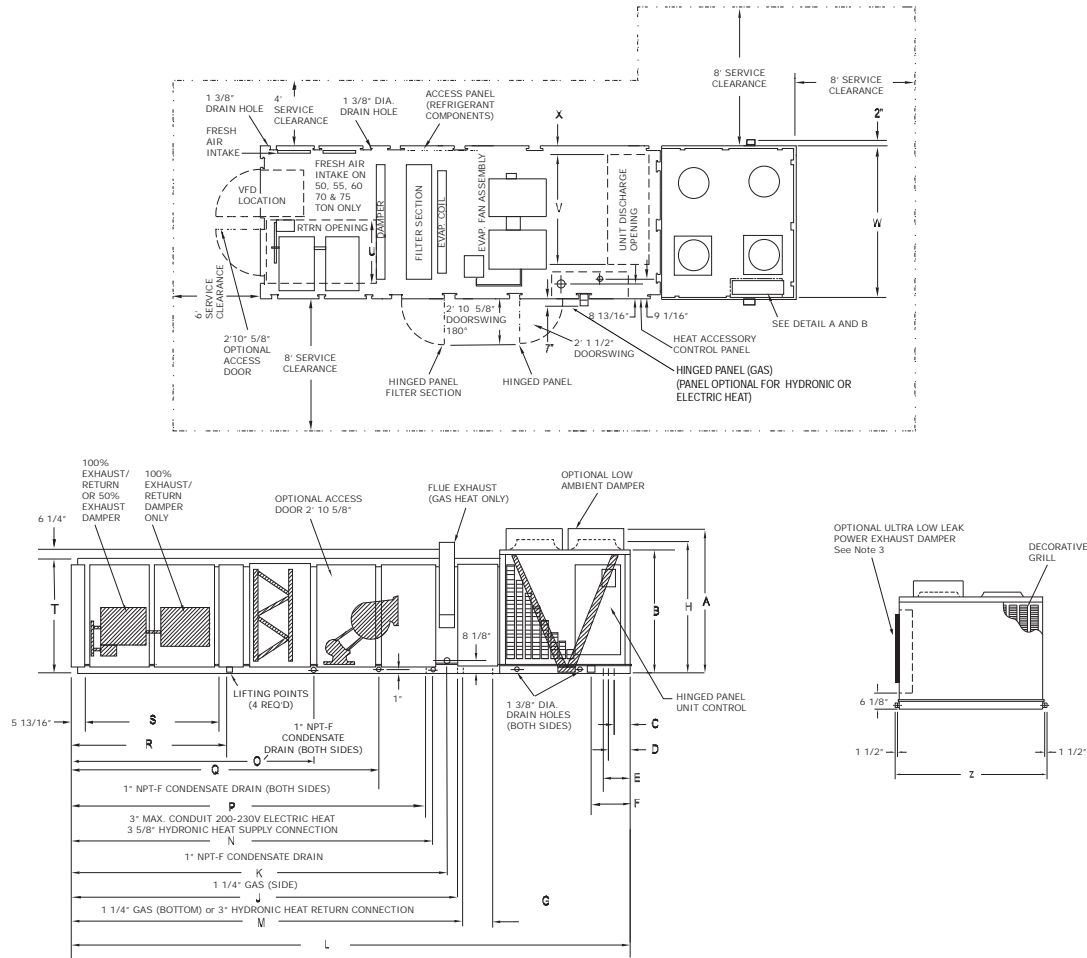

Table 78. Heating/cooling unit dimensions (ft. in.) - air-cooled - SEHL, SFHL, SSSL, SLHL, SXHL

Nom. Tons	H	L	W	A	B	C	D	E	F	G	J(a)	K(a)	M
20 & 25	7-3 1/4	24-1 3/8	7-6 1/2	7-10 5/8	6-9	0-9 1/2	1-3 5/8	1-7 9/16	1-3 1/2	2-2 1/2	16-9 3/4	16-6	16-3 13/16
											16-9 3/4	16-6	
30	7-3 1/4	24-1 3/8	7-6 1/2	7-10 5/8	6-9	0-9 1/2	1-3 5/8	1-7 9/16	1-3 1/2	2-2 1/2	16-9 3/4	16-6	16-3 13/16
											16-9 3/4	16-6	
40	7-3 1/4	32-10 1/2	7-6 1/2	7-10 5/8	6-9	0-9 7/8	1-5 7/8	1-10 1/8	2-5	2-5	20-1 3/4	19-6	19-10 5/16
											20-6 3/4	20-3	
50 & 55	7-3 1/4	32-10 1/2	7-6 1/2	7-10 5/8	6-9	0-9 7/8	1-5 7/8	1-10 1/8	2-5	2-5	20-1 3/4	19-6	19-10 5/16
											20-6 3/4	20-3	
60	7-3 1/4	32-10 1/2	9-8	7-10 5/8	6-9	0-9 7/8	1-5 7/8	1-10 1/8	2-5	2-5	20-1 3/4	19-6	19-10 5/16
											20-6 3/4	20-3	
70 & 75	7-3 1/4	32-10 1/2	9-8	7-10 5/8	6-9	0-9 7/8	1-5 7/8	1-10 1/8	2-5	2-5	20-1 3/4	19-6	19-10 5/16
											20-6 3/4	20-3	

Continued on next page

Table 78. Heating/cooling unit dimensions (ft. in.) - air-cooled - SEHL, SFHL, SSSL, SLHL, SXHL

Nom. Tons	N	O	P	Q	R	S		T	U		V	X	Z
						w/ exhaust fan	w/ return fan		w/ exhaust fan	w/ return fan			
20 & 25	16-7	10-7	15-5 ⁵ / ₁₆	13-3	7-0	6-6 ¹⁵ / ₁₆	3-0	3-9 ⁵ / ₁₆	3-4 ³ / ₈	2-9 ¹⁵ / ₁₆	5-7	0-5 ¹³ / ₁₆	7-9 ¹ / ₂
30	16-7	10-7	15-5 ⁵ / ₁₆	13-3	7-0	6-6 ¹⁵ / ₁₆	3-0	4-9 ⁵ / ₁₆	3-4 ³ / ₈	2-9 ¹⁵ / ₁₆	5-7	0-5 ¹³ / ₁₆	7-9 ¹ / ₂
40	19-7	12-1	18-11 ¹¹ / ₁₆	15-11 ¹ / ₈	8-0	7-8 ³ / ₁₆	3-4	5-9 ⁵ / ₁₆	3-4 ³ / ₈	3-1 ¹ / ₂	5-7	0-5 ¹³ / ₁₆	7-9 ¹ / ₂
50 & 55	19-7	12-1	18-11 ¹¹ / ₁₆	15-11 ¹ / ₈	8-0	7-8 ³ / ₁₆	3-4	6-9 ³ / ₈	3-4 ³ / ₈	3-1 ¹ / ₂	5-7	0-5 ¹³ / ₁₆	7-9 ¹ / ₂
60	19-7	12-1	18-11 ¹¹ / ₁₆	15-11 ¹ / ₈	8-0	7-8 ³ / ₁₆	4-5	5-9 ⁵ / ₁₆	4-5 ³ / ₈	4-2 ¹ / ₂	7-8 ¹ / ₂	0-5 ¹³ / ₁₆	9-11
70 & 75	19-7	12-1	18-11 ¹¹ / ₁₆	15-11 ¹ / ₈	8-0	7-8 ³ / ₁₆	4-5	5-9 ⁵ / ₁₆	4-5 ³ / ₈	4-2 ¹ / ₂	7-8 ¹ / ₂	0-5 ¹³ / ₁₆	9-11

Notes:

1. Unit drawing is representative only and may not accurately depict all models.
2. Use high gas heat J dimension for all hydronic heat connections.
3. Optional Ultra Low Leak Power Exhaust extends beyond lifting lug and increases overall "U" and "Z" dimension by 0.65".

(a) In columns J and K: top dimension = high gas heat, bottom dimension = low gas heat.

Dimensional Data

Figure 30. Optional roof curb dimensions (downflow) – 20 - 75 ton air cooled

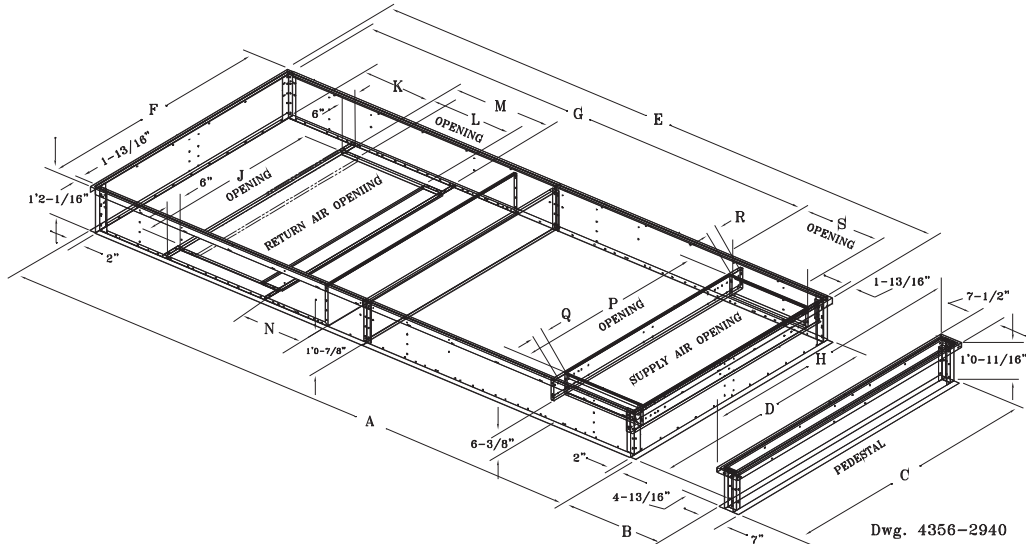

- Note:**
1. The pedestal was purposely designed $1 \frac{3}{8}$ " shorter than the curb because the unit base rails rest on the pedestal at one point and on the curb at a different point.

Table 79. Downflow roof curb dimensions (ft. in.) – 20 - 75 ton air cooled

Tons	Model	A	B	C	D	E	F	G	H	J
20,25,30	SAHL	16'-3 $\frac{7}{8}$ "	2'-10 $\frac{1}{16}$ "	7'-10 $\frac{7}{16}$ "	7'-0 $\frac{13}{16}$ "	16'-3 $\frac{9}{16}$ "	7'-0 $\frac{1}{2}$ "	13'-6 $\frac{15}{16}$ "	7'-11 $\frac{15}{16}$ "	5'-8 $\frac{13}{16}$ "
	S*HL	18'-7 $\frac{1}{2}$ "	2'-10 $\frac{1}{16}$ "	7'-10 $\frac{7}{16}$ "	7'-0 $\frac{13}{16}$ "	18'-7 $\frac{3}{16}$ "	7'-0 $\frac{1}{2}$ "	15'-10 $\frac{9}{16}$ "	7'-11 $\frac{15}{16}$ "	5'-8 $\frac{13}{16}$ "
40, 50,55	SAHL	19'-1 $\frac{15}{16}$ "	7'-10 $\frac{1}{16}$ "	7'-10 $\frac{7}{16}$ "	7'-0 $\frac{13}{16}$ "	19'-1 $\frac{5}{8}$ "	7'-0 $\frac{1}{2}$ "	16'-2 $\frac{9}{16}$ "	7'-11 $\frac{15}{16}$ "	5'-8 $\frac{13}{16}$ "
	S*HL	22'-4 $\frac{1}{2}$ "	7'-10 $\frac{1}{16}$ "	7'-10 $\frac{7}{16}$ "	7'-0 $\frac{13}{16}$ "	22'-4 $\frac{1}{8}$ "	7'-0 $\frac{1}{2}$ "	19'-5"	7'-11 $\frac{15}{16}$ "	5'-8 $\frac{13}{16}$ "
60,70,75	SAHL	19'-1 $\frac{15}{16}$ "	7'-10 $\frac{1}{16}$ "	9'-11 $\frac{15}{16}$ "	9'-2 $\frac{5}{16}$ "	19'-1 $\frac{5}{8}$ "	9'-2"	16'-2 $\frac{9}{16}$ "	10'-1 $\frac{7}{16}$ "	7'-10 $\frac{5}{16}$ "
	S*HL	22'-4 $\frac{1}{2}$ "	7'-10 $\frac{1}{16}$ "	9'-11 $\frac{15}{16}$ "	9'-2 $\frac{5}{16}$ "	22'-4 $\frac{1}{8}$ "	9'-2"	19'-5"	10'-1 $\frac{7}{16}$ "	7'-10 $\frac{5}{16}$ "
Tons	Model	K	L	M	N	P	Q	R	S	
20,25,30	SAHL	2'-0"	2'-5 $\frac{5}{16}$ "	2'-11 $\frac{5}{16}$ "	1'-10 $\frac{5}{8}$ "	5'-9 $\frac{1}{2}$ "	0'-5 $\frac{11}{16}$ "	0'-5 $\frac{11}{16}$ "	2'-3 $\frac{5}{16}$ "	
	S*HL	2'-0"	2'-5 $\frac{5}{16}$ "	2'-11 $\frac{5}{16}$ "	1'-10 $\frac{5}{8}$ "	5'-7 $\frac{3}{8}$ "	1'-0 $\frac{7}{16}$ "	0'-1"	2'-3 $\frac{5}{16}$ "	
40, 50,55	SAHL	2'-0"	3'-6"	4'-0"	1'-10 $\frac{5}{8}$ "	5'-9 $\frac{1}{2}$ "	0'-5 $\frac{11}{16}$ "	0'-5 $\frac{11}{16}$ "	2'-5 $\frac{15}{16}$ "	
	S*HL	2'-0"	3'-6"	4'-0"	1'-10 $\frac{5}{8}$ "	5'-7 $\frac{3}{8}$ "	0'-11 $\frac{3}{16}$ "	0'-2 $\frac{1}{4}$ "	2'-5 $\frac{15}{16}$ "	
60,70,75	SAHL	2'-0"	3'-6"	4'-0"	1'-10 $\frac{5}{8}$ "	6'-11 $\frac{7}{8}$ "	0'-11 $\frac{3}{16}$ "	0'-11 $\frac{3}{16}$ "	2'-5 $\frac{15}{16}$ "	
	S*HL	2'-0"	3'-6"	4'-0"	1'-10 $\frac{5}{8}$ "	7'-8 $\frac{3}{4}$ "	0'-11 $\frac{3}{16}$ "	0'-2 $\frac{3}{8}$ "	2'-5 $\frac{15}{16}$ "	

- Note:** The return opening of the roof curb is provided with an adjustable filler panel six inches wide. This panel allows adjustment of the return air opening in order to clear roof members of all standard roof constructions with both the supply and return openings. The return air opening of the curb is at a 90 degree angle as compared to the rooftop return air opening to allow this placement flexibility. The curb acts as a plenum between the ductwork and the unit return opening. A retainer clip is used to secure the adjustable filler piece to the roof curb.

Figure 31. Heating/cooling and cooling only rooftops – 90, 105, 115, 130 ton air-cooled

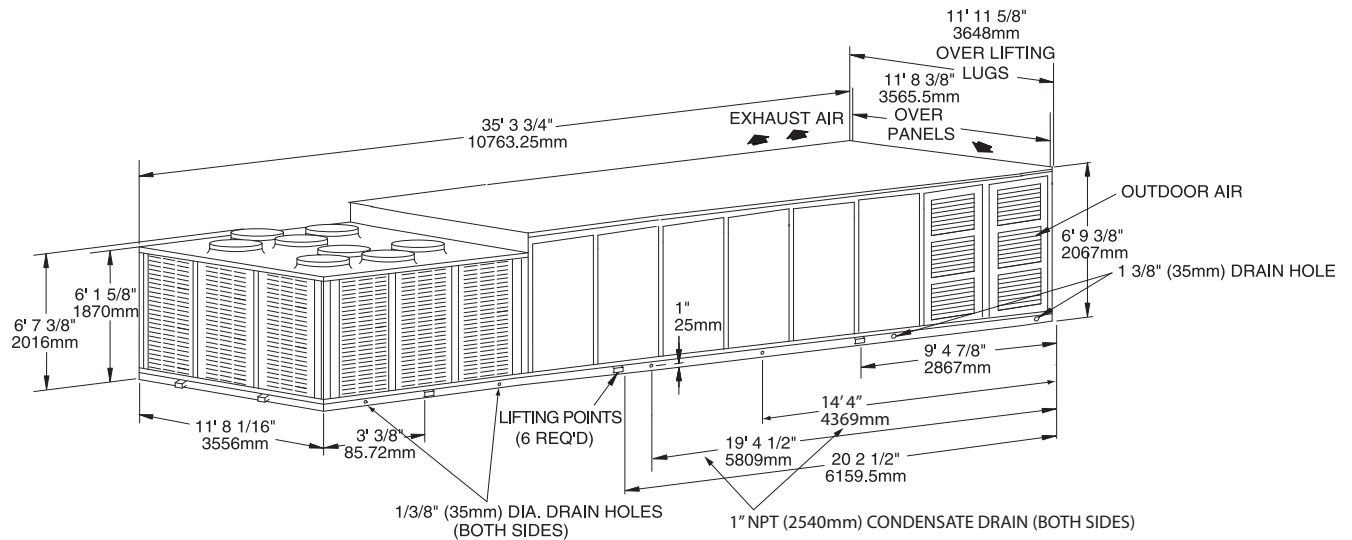

Note: Design order special Ultra Low Leak Power Exhaust Damper extends 0.65" beyond lifting lugs.

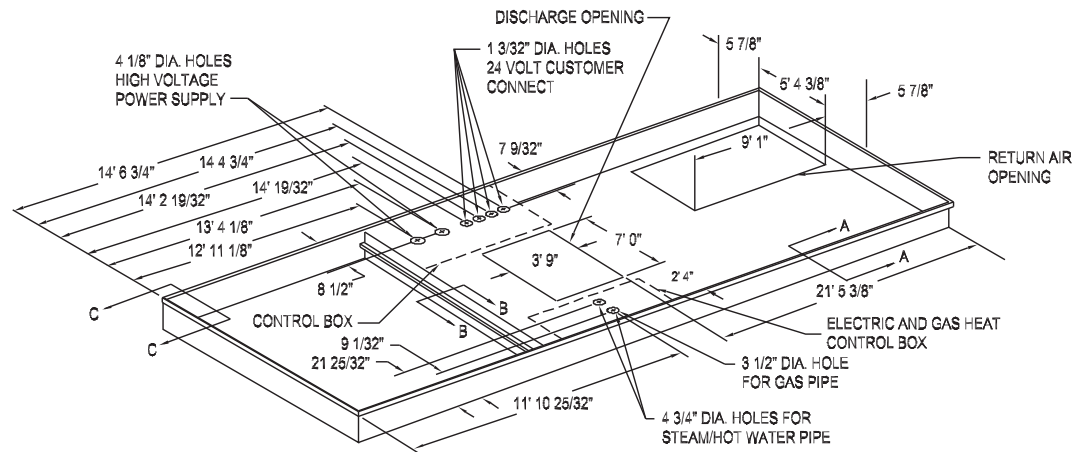

Dimensional Data

Figure 32. Service clearance — 90 - 130 tons air-cooled

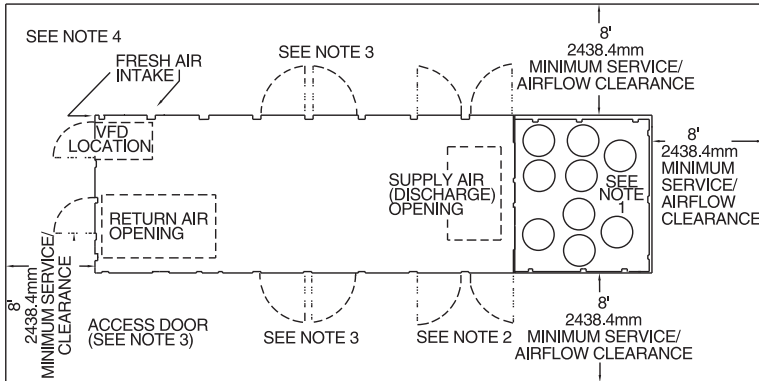

Notes:

1. Provide unrestricted clearance over the condenser fans.
2. A minimum clearance of 2' 4-1/2" is required to open the hinged control panel doors. Both doors swing outward in a 180-degree arc.
3. A minimum clearance of 2' 10-3/4" is required to open the access doors on the unit's supply fan, evaporator, filter and exhaust fan sections. All hinged doors swing outward in a 180-degree arc.
4. 90-130 ton models have two outdoor air intakes located at the back of the unit and one small outdoor air intake located at the end of the unit.
5. A minimum clearance of 3' 7" is required to open the hinged access panel door to the VFD enclosure.
6. Unit drawing is representative only and may not accurately depict all models.

Figure 33. Roof curb dimensions — 90 - 130 ton air-cooled

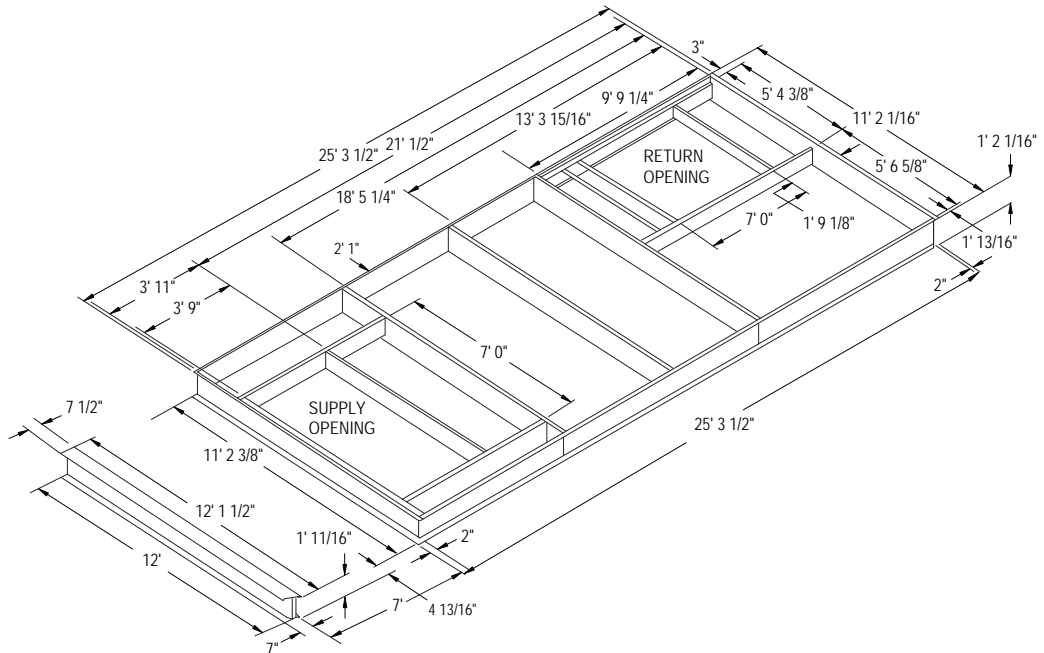

Notes:

1. The pedestal was purposely designed 1 3/8" shorter than the curb because the unit base rails rest on the pedestal at one point and on the curb at a different point.
2. Curb dimensions shown are for units with air-cooled condensers; for design special units with evaporative condensers, please see curb installation guide RT-SVN06*-EN.

Cross section thru roof curb and base pan

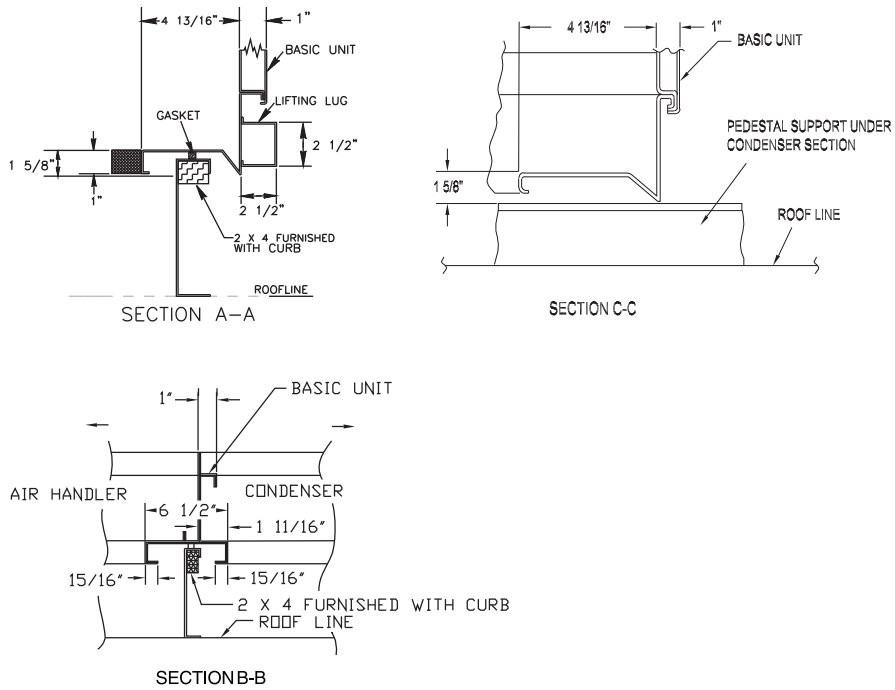

Field Installed Sensors

Figure 34. Field installed zone sensor—programmable night setback sensor (BAYSENS119*)

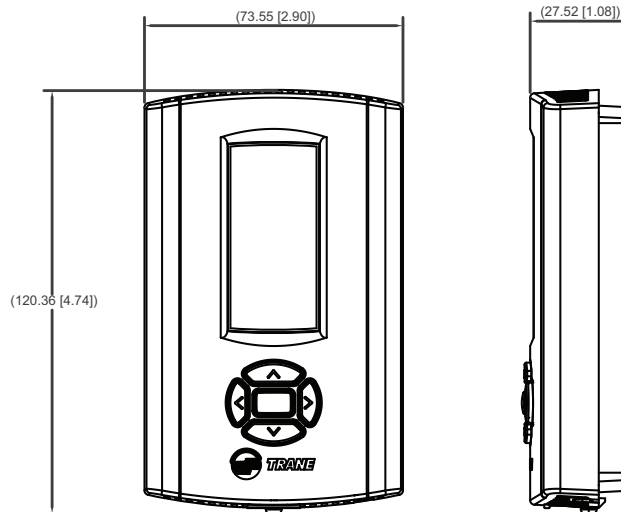

Note: Remote sensors are available for use with all zone sensors to provide remote sensing capabilities.

Dimensional Data

Figure 35. Field installed zone sensor—dual setpoint, manual/automatic changeover with system function lights (BAYSENS110*), without LED function lights (BAYSENS108*), single setpoint without LED function lights (BAYSENS106)

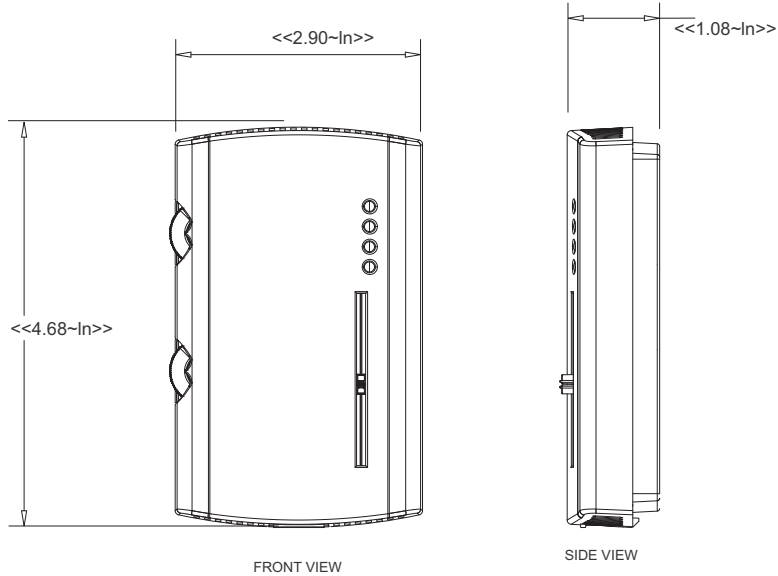
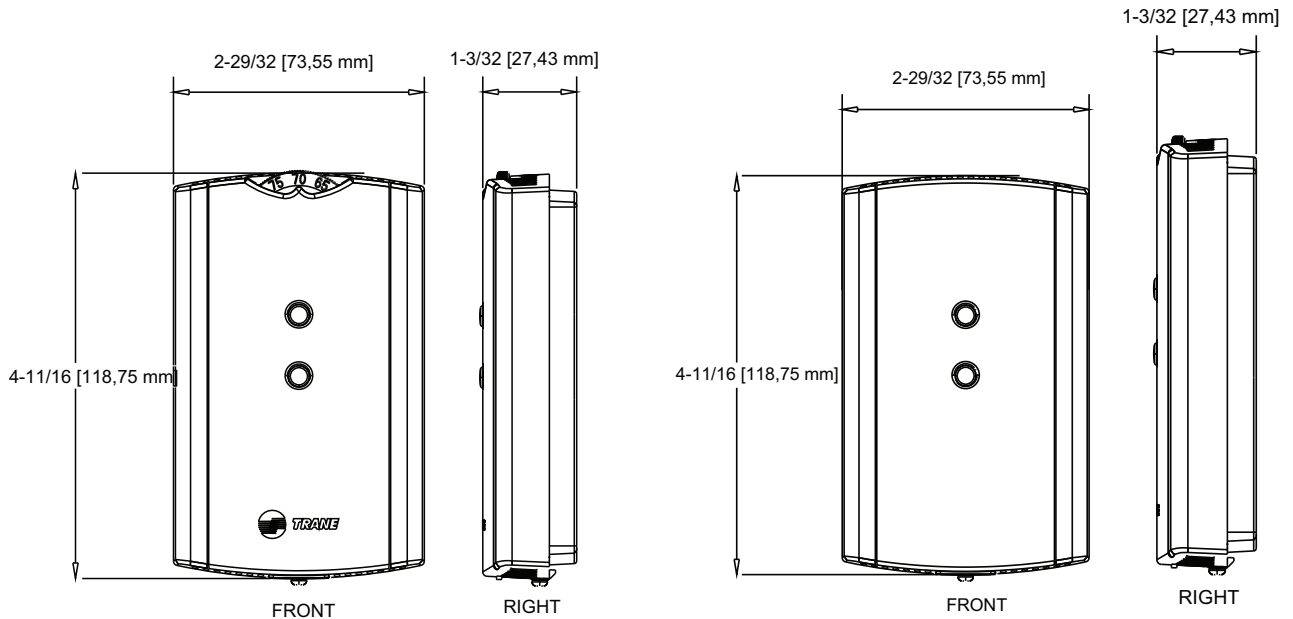

Figure 36. Field installed zone sensor—with timed override button and local setpoint adjustment (BAYSENS074*), with timed override only (BAYSENS073*), sensor only (BAYSENS077*)



Note: Remote sensors are available for use with all zone sensors to provide remote sensing capabilities.

Figure 37. Field installed temperature sensor (BAYSENS016*)



Figure 38. Field installed remote minimum position potentiometer control (BAYSTAT023*)

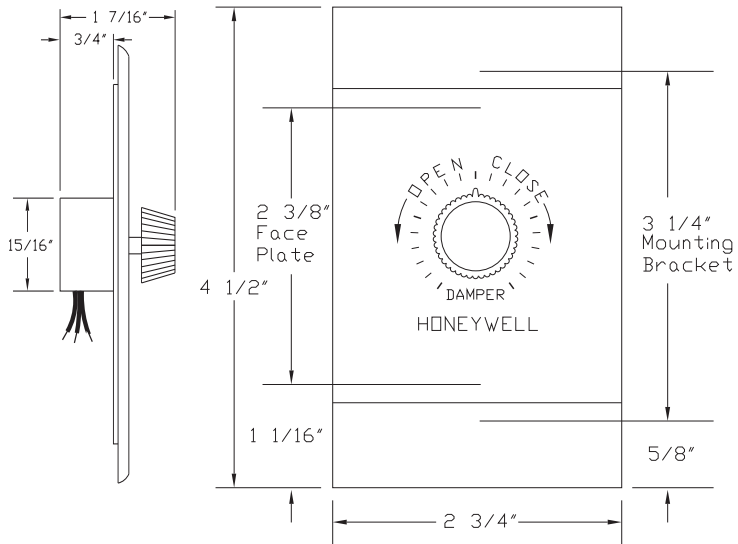
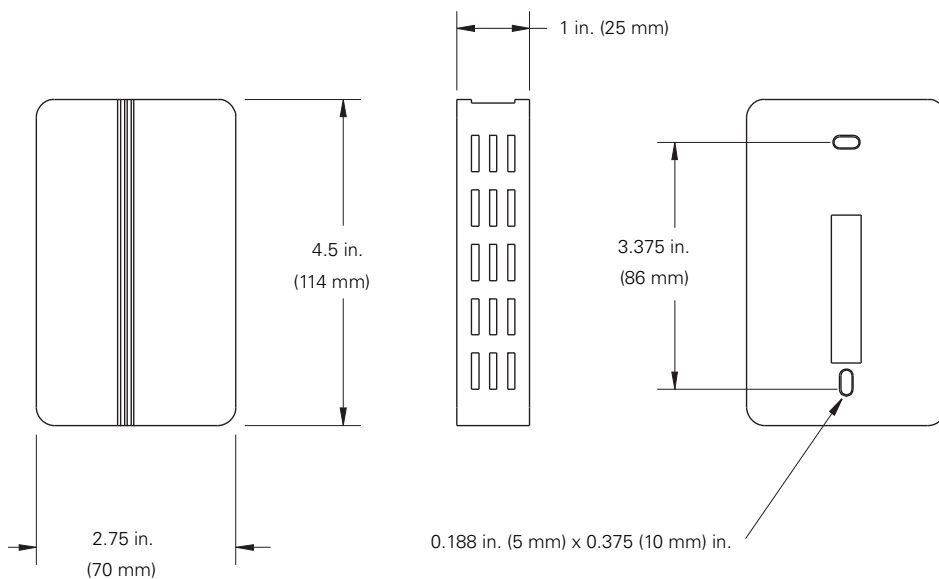

Figure 39. Field installed humidity sensor—wall (BAYSENS036*) or duct mount (BAYSENS037*)



Weights

Table 80. Air-cooled condenser - approximate operating weights (Lbs./Kg)

Unit		Without Exhaust Fan					With Exhaust Fan				
		SA	SX	SE	SF	SL/SS	SA	SX	SE	SF	SL/SS
20	Lb	4116	4336	4446	4736	4446	4414	4634	4744	5034	4744
	Kg	1867	1967	2017	2148	2017	2002	2102	2152	2283	2152
25	Lb	4209	4419	4549	4819	4419	4513	4723	4853	5123	4853
	Kg	1909	2004	2063	2186	2004	2047	2142	2201	2324	2201
30	Lb	4598	4838	4958	5228	4838	5055	5295	5415	5685	5415
	Kg	2086	2194	2249	2371	2194	2293	2402	2456	2579	2456
40	Lb	6511	6891	7051	7531	6891	7181	7561	7721	8201	7721
	Kg	2953	3126	3198	3416	3126	3257	3430	3502	3720	3502
50	Lb	7236	7616	7786	8246	7616	7955	8335	8505	8965	8505
	Kg	3282	3455	3532	3740	3455	3608	3781	3858	4066	3858
55	Lb	7484	7874	8034	8514	7874	8203	8593	8753	9233	8753
	Kg	3395	3572	3644	3862	3572	3721	3898	3970	4188	3970
60	Lb	8396	8612	8772	9232	8612	9339	9555	9715	10175	9715
	Kg	3808	3906	3979	4188	3906	4236	4334	4407	4615	4407
70	Lb	8659	8839	8989	9469	8839	9602	9782	9932	10412	9932
	Kg	3928	4009	4077	4295	4009	4355	4437	4505	4723	4505
75	Lb	8912	9092	9242	9722	9092	9855	10035	10185	10665	10185
	Kg	4042	4124	4192	4410	4124	4470	4552	4620	4838	4620
90	Lb.	x	12493	12648	13293	13343	x	13831	13986	14631	14681
	Kg	x	5667	5737	6030	6052	x	6273	6344	6637	6659
105	Lb.	x	13126	13281	13926	13976	x	14464	14619	15264	15314
	Kg	x	5954	6024	6317	6339	x	6561	6631	6924	6946
115	Lb.	x	13330	13485	14130	14180	x	14668	14823	15468	15518
	Kg	x	6046	6117	6409	6432	x	6653	6724	7016	7039
130	Lb.	x	13616	13771	14416	14466	x	14954	15109	15754	15829
	Kg	x	6176	6246	6539	6562	x	6783	6853	7146	7180

Notes:

- Weights shown are for air-cooled units with standard capacity, standard efficiency and include the following features: FC fans, standard scroll compressors, 100% economizer, throwaway filters, maximum motor sizes, 460V XL start, high capacity heat.
- Weights shown represent approximate operating weights and have a ±5% accuracy. To calculate weight for a specific unit configuration, utilize TOPSS™ or contact the local Trane sales representative. ACTUAL WEIGHTS ARE STAMPED ON THE UNIT NAMEPLATE.

Table 81. Roof curb max weight^(a) (Lbs/Kg)

Unit		Roof Curb Max. Weight (b)	
		SAHL	S*HL
20, 25, 30	Lb	490	510
	Kg	222	231
40, 50, 55, 60	Lb	515	550
	Kg	234	249
70, 75	Lb	610	640
	Kg	277	290
90-130	Lb	N/A	770
	Kg	N/A	349

(a) Roof curb weights include the curb and pedestal.

Options

Table 82. Comprehensive listing of available options and accessories^(a)

Option or Accessory	Standard	Factory Design Special ^{(b)(c)}	Enhanced Design Facility Special ^{(b)(c)}	Standard Field Installed Accessory
Coils				
Complete Coat evaporator coils		X		
Black epoxy evaporator coils		X		
Copper finned evaporator coils (20-75 ton only)		X		
Corrosion protected condenser coil	X			
Copper finned air-cooled condenser coils			X	
High capacity evaporator coils (105 ton)	X			
High efficiency air-cooled condenser coils (90 ton)	X			
Controls				
LonTalk® Communication Interface (LCI)	X			X
BACnet Communication Interface (BCI)	X			X
Wireless Comm Interface (WCI)				X
Generic BAS (Building Automation System) interface	X	X		
Inter-Processor Communication Bridge	X	X		
Kits available for field control upgrades				X
No Controls		X		
Remote Human Interface Panel (controls up to 4 units)	X			
Remote minimum position control for economizer				X
Single Zone VAV	X			
Rapid Restart	X			
Outside Air Measurement (TraQ™)	X			
Trane Communication Interface Module: ICS interface control module (TCI)	X			
Variable frequency drive (VFD) control of supply/exhaust fan motor	X			
Ventilation override module (five ventilation override sequences)	X			
Supply Fan Piezometer	X			
Curbs				
Roof curbs				X
Roof curbs-Special design, including curbs for "twinning" large units together			X	
Dampers				
0-25 percent manual dampers	X			
Barometric relief exhaust dampers		X		
Low ambient control dampers-0°F (20-75 ton)	X			
Low ambient control dampers (90-130 ton)			X	
Low leak dampers for 0-100 percent modulating outside air economizer	X			
Ultra low leak economizer and exhaust		X		
Drain Pans				
Positively sloping evaporator coil drain pan		X		
Stainless steel positively sloping evaporator coil drain pan		X		
Economizer				
0-100 percent modulating outside air economizer	X			
Economizer control options: comparative enthalpy, reference enthalpy, dry bulb	X			

Options

Table 82. Comprehensive listing of available options and accessories^(a) (continued)

Option or Accessory	Standard	Factory Design Special ^{(b)(c)}	Enhanced Design Facility Special ^{(b)(c)}	Standard Field Installed Accessory
Energy Recovery				
Energy Recovery Wheel			X	
Electrical				
Convenience Outlet (Factory-powered 15A GFI)	X			
Dual power source		X		
Unit disconnect - through-the-door, non-fused disconnect with external handle	X			
Phase monitors (200/230/460/575V) (S_HL 20-75 tons)	X			
Phase monitors (460/575; S_HK 90-130 tons)			X	
Power factor correction capacitors - compressors and fans		X		
Evaporative Condenser (S_HL only)				
Evaporative Condenser	X			
Sump Heater	X			
Dolphin WaterCare® system	X			
Conductivity Controller	X			
Fans				
100 percent modulating exhaust w/or without Statitrac space pressure control	X			
100 percent modulating return w/ or without Statitrac space pressure control (20-75 tons)	X			
50 percent modulating exhaust	X			
eDrive™ direct drive plenum supply fans - 80% width and 120% width (20-75 tons)	X			
Alternative supply fans			X	
Horizontal Return fans (20-75 tons)		X		
Filters, Filter Racks and Related Tools				
90-95 percent bag filters	X			
90-95 percent cartridge filters	X			
90-95 percent bag or cartridge final filters and rack		X		
Filter rack only (no filters)	X			
Final filters, cartridge (SX only)	X			
Final filter rack only		X		
Filter rack - 4" deep panel rack placed in standard rack location		X		
High efficiency throwaway filters	X			
Replaceable core filter driers		X		
Differential pressure gauge	X			
Heat				
Heat modules		X		
Heating options: natural gas, electric, hot water or steam	X			
Modulating gas heat - full or limited	X			
Propane (LP) conversion / Modulating LP heat		X		
Insulation				
Double wall with perforated interior liner		X		
Manville Tuf-Skin® insulation w/ 25/50 flame/smoke development rating		X		
Solid double wall		X		

Table 82. Comprehensive listing of available options and accessories^(a) (continued)

Option or Accessory	Standard	Factory Design Special^{(b)(c)}	Enhanced Design Facility Special^{(b)(c)}	Standard Field Installed Accessory
Motors				
40 & 50 hp 200 and 230 volt motors - supply fan		X		
Totally enclosed fan-cooled (TEFC) motors		X		
Totally enclosed non-ventilated (TENV) motors - Condenser fan only		X		
Motors with internal shaft grounding ring for VFD applications	X			
1.5 HP motor - exhaust fan		X		
Two-speed motors - supply fan		X		
Other				
Access doors (hinged)	X	X		
Burglar Bars			X	
eFlex™ Variable Speed Compressors (40 - 70 ton only)	X			
Digital Scroll Compressor (20-30 ton only)		X		
Extended grease lines		X		
Modulating hot gas reheat dehumidification (20-75 air-cooled only)	X			
Horizontal supply and return openings (SX,SL,SS,SL models only)		X		
Hot gas bypass to the evaporator inlet	X			
IntelliPak™ Replacement Unit (IRU)	X			
Outside air CFM compensation on VAV units with VFD and economizer	X			
Reversal of return/outside air sections with exhaust fans			X	
Safety grates installed over supply and return		X		
Special paint colors		X		
Spring isolators	X			
Suction service valves		X		
Ultra-extended cabinet to accommodate field installed humidifiers, final filters, sound attenuators, wing coils, air blenders, special filters, etc.			X	
Vertical discharge, S_HL 20-75 tons (SX,SL,SS,SL models only)		X		
VFD line reactor		X		
VFD - Enclosure for field installed VFD		X		
Sensors and Thermostats				
Humidity sensor				X
ICS zone sensors used with Tracer system for zone control				X
High duct temperature thermostats	X			
Outdoor temperature sensor for units without economizers				X
Programmable sensors with night set back — CV and VAV				X
Remote zone sensors — used for remote sensing with remote panels				X
Sensors without night set back — CV and VAV				X
Warranty				
10 year limited warranty on Full Modulation Gas Heat	X			

(a) Options are provided for informational purposes only. For specifics, contact your local Trane sales office.

(b) Special Options may be subject to a net price add.

(c) For information on agency approval for special designs, contact your local Trane sales office.

Mechanical Specifications

General

Units shall be specifically designed for outdoor rooftop installation on a roof curb and be completely factory assembled and tested, piped, internally wired, fully charged with R-410A compressor oil, factory run tested and shipped in one piece. Units shall be available for direct expansion cooling only, or direct expansion cooling with natural gas, electric, hot water or steam heating. Filters, outside air system, exhaust air system, optional non-fused disconnect switches and all operating and safety controls shall be furnished factory installed.

All units shall be UL listed to US and Canadian Safety Standards. Cooling capacity shall be rated in accordance with AHRI Standard 360. All units shall have decals and tags to aid in service and indicate caution areas. Electrical diagrams shall be printed on long life water resistant material and shall ship attached to control panel doors.

Casing

Exterior panels shall be zinc coated galvanized steel, phosphatized and painted with a slate grey air-dry finish durable enough to withstand a minimum of 500 hours consecutive salt spray application in accordance with standard ASTM B117. Screws shall be coated with zinc-plus-zinc chromate. Heavy gauge steel hinged access panels with tiebacks to secure door in open position shall provide access to filters and heating sections.

Refrigeration components, supply air fan and compressor shall be accessible through removable panels as standard. Unit control panel, filter section, and gas heating section shall be accessible through hinged access panels as standard. Optional Double Wall Construction hinged access doors shall provide access to filters, return/exhaust air, heating and supply fan section. All access doors and panels shall have neoprene gaskets. Interior surfaces or exterior casing members shall have ½ inch Manville Tuf-Skin® fiberglass insulation. Unit base shall be watertight with heavy gauge formed load bearing members, formed recess and curb overhang. Unit lifting lugs shall accept chains or cables for rigging. Lifting lugs shall also serve as unit tiedown points.

Refrigeration System

Compressors

The Trane 3-D® scroll compressors have a simple mechanical design with only three major moving parts. Scroll type compression provides inherently low vibration. The 3-D® scroll provides a completely enclosed compressor chamber with optimized scroll profiles which leads to increased efficiency. The 3-D® scroll includes a direct-drive, 3,600 rpm, suction gas cooled hermetic motor. Dependent on the compressor model, motor protection is provided by either a patented motor cap and integral line break motor protector or an external 24 VAC module which provides protection against incorrect phase sequence, excess motor temperatures, over current protection, and phase loss.

Trane 3-D® compressor includes centrifugal oil pump, scroll tips seals, internal heat shield that lowers the heat transfer from discharge and suction gas, oil level sight glass and oil charge valve. Some compressor models also provide a dip tube that allows for oil draining, in addition to a low leakage internal discharge check valve to help prevent refrigerant migration. Each compressor shall have a crankcase heater installed, properly sized to minimize the amount of liquid refrigerant present in the oil sump during off cycles.

eFlex™ Variable Speed Compressors

(200/230/460/575V)

The Trane eFlex™ variable speed compressor shall be capable of speed modulation from 25 Hz to a maximum of 100 Hz. The minimum unit capacity shall be 15% of full load or less. The compressor motor shall be a permanent magnet type. Each compressor shall have a crankcase heater installed, properly sized to minimize the amount of liquid refrigerant present in the oil sump during off cycles. Compressors shall be equipped with a thrust bearing oil injection system that optimizes scroll set

lubrication and controls the oil circulation rate. Optimal bearing lubrication shall be provided by a gerotor oil pump.

Each variable speed compressor shall be matched with a specially designed variable frequency drive which modulates the speed of the compressor motor and provides several compressor protection functions. Control of the variable speed compressor and inverter control shall be integrated with the IPak unit controller to ensure optimal equipment reliability and efficiency.

Phase and Voltage Monitor

Standard on 20-75 ton air-cooled units. Protects 3-phase equipment from phase loss, phase reversal and low voltage. Any fault condition will produce a Failure Indicator LED and send the unit into an auto stop condition. cULus approved.

Power Supplies

The 20-75 ton air-cooled rooftops are available with 200, 230, 460 and 575 voltage power supplies and 90-130 tons units are available with 460 or 575 voltage power supplies.

Evaporator Coil

Internally enhanced copper tubing of 3/8 or 1/2-inch O.D. shall be mechanically bonded to heavy-duty aluminum fins of configured design. All coils shall be equipped with thermal expansion valves and factory pressure and leak tested.

Air-Cooled Condensing

Air-Cooled Condenser Coil

Condenser coils shall have all Aluminum Microchannel coils. All coils shall be leak tested at the factory to ensure pressure integrity. The condenser coil is pressure tested to 650 psig. Subcooling circuit(s) shall be provided as standard.

Air-Cooled Condenser Fans and Motors

All condenser fans shall be vertical discharge, direct drive fans, statically balanced, with aluminum blades and zinc plated steel hubs. Condenser fan motors shall be three-phase motors with permanently lubricated ball bearings, built-in current and thermal overload protection and weather-tight slingers over motor bearings.

Air Handling System

Supply Fan

Supply fan motors are open drip-proof. All supply fans shall be dynamically balanced in factory. Supply fan shall be test run in unit and shall reach rated rpm. All 60 Hz supply fan motors meet the Energy Independence Security Act of 2007 (EISA). All 50 Hz supply fan motors meet the U.S. Energy Policy Act of 1992 (EPACT).

20-75 Ton Air-Cooled with Forward Curved Supply Fan

Supply fans shall have two double-inlet, forward-curved fans mounted on a common shaft with fixed sheave drive. Fans shall be factory-tested to reach rated rpm before the fan shaft passes through first critical speed. Fan shaft shall be mounted on two grease lubricated ball bearings designed for 200,000 hours average life. Optional extended grease lines shall allow greasing of bearings from unit filter section. Fan motor and fan assembly shall be mounted on common base to allow consistent belt tension with no relative motion between fan and motor shafts. Entire assembly shall be completely isolated from unit and fan board by double deflection rubber-in-shear isolators, or by optional 2" deflection spring isolation.

20-75 Ton Air-Cooled with eDrive™ Direct-Drive Plenum Supply Fan

The eDrive™ direct drive plenum supply fan shall be [one] [two] single width, single inlet 9-blade plenum fan. Fan blades shall be aluminum backward-inclined airfoil. Plenum fans shall be direct-

Mechanical Specifications

driven. Entire assembly shall be completely isolated from unit and fan board by 2" deflection spring isolation. Multiple fan widths shall be available to optimize efficiency. Fan shall not require routine maintenance such as fan bearing lubrication, belt tensioning and replacement, sheave alignment, and setscrew torque checks.

90 - 130 Ton Air-Cooled

All supply fans shall have two independent fan assemblies with double inlet, air foil fan, motor and fixed pitch sheave drive. All fans shall be statically and dynamically balanced and tested in factory. Supply fans shall be test run in unit as part of unit test. Unit shall reach rated rpm before fan shaft passes through first critical speed. Fan shafts shall be mounted on two grease lubricated ball bearings designed for 200,000 hours average life.

Optional extended grease lines shall allow greasing of bearings from unit filter section. Fan motor and fan assembly shall be mounted on common base to allow consistent belt tension with no relative motion between fan and motor shafts. Entire assemblies shall be completely isolated from unit and fan board by two-inch deflection spring isolators.

System Control

- Constant Volume Zone Temperature Control - Provided with all the necessary controls to operate rooftop from a zone sensor, including CV microprocessor unit control module, a microprocessor compressor controller and a unit mounted Human Interface Panel.
- Constant Volume with Discharge Temperature Control - Provided with all the necessary controls to operate a CV rooftop with discharge air temperature control, including discharge air microprocessor controller and discharge air sensor. The microprocessor controller coordinates the economizer control and the stages of cooling with zone or outdoor air reset capabilities and an adjustable control band to fine-tune the control to specific applications.
- CV Zone Temperature Control and Exhaust/Return Fan Variable Frequency Drives w/o Bypass (with Statitrac Only) - Provided with all the necessary controls to control/maintain building space pressure through a CV rooftop. The Variable Frequency Drive (VFD) modulates the speed of the exhaust/return fan motor in response to building pressure.

A differential pressure control system, called Statitrac, uses a differential pressure transducer to compare indoor building pressure to atmospheric pressure. The VFD receives a 0-10 VDC signal from the unit microprocessor based upon the space static pressure and causes the drive to accelerate or decelerate as required to maintain the space pressure within the deadband.

- CV Zone Temperature Control and Exhaust/Return Fan Variable Frequency Drives and Bypass (with Statitrac Only) -Bypass control provides full nominal airflow in the event of drive failure.
- VAV Discharge Temperature Control with Variable Frequency Drives without Bypass - Provided with all necessary controls to operate a VAV rooftop from the discharge air temperature, including discharge air microprocessor controller and discharge air sensor.

The microprocessor controller coordinates the economizer control and the stages of cooling with discharge air temperature reset capabilities. Includes factory installed and tested variable frequency drives (VFD) to provide supply fan motor speed modulation. VFD receives 0-10 VDC from the unit microprocessor based upon supply static pressure and causes the drive to accelerate or decelerate as required to maintain the supply static pressure setpoint.

- VAV Supply Air Temperature Control with Variable Frequency Drives and Bypass - Bypass control provides full nominal airflow in the event of drive failure.
- Single Zone Variable Air Volume - Single Zone VAV option shall be provided with all necessary controls to operate a rooftop unit based on maintaining two temperature setpoints: discharge air and zone. Option shall include factory-installed variable frequency drive (VFD) to provide supply fan motor speed modulation. During One Zone VAV cooling, the unit will maintain zone cooling setpoint by modulating the supply fan speed more or less to meet zone load demand; and the unit will maintain discharge temperature to the discharge cooling setpoint by modulating economizer if available and staging dx cooling.

Controls

Unit shall be completely factory wired with necessary control and contactor pressure lugs or terminal block for power wiring. Units shall provide an internal location for a non-fused disconnect with external handle for safety. Unit mounted microprocessor controls shall provide anti-short cycle timing for compressors to provide a high level of machine protection.

Unit Controller

DDC microprocessor controls shall be provided to control all unit functions. The control system shall be suitable to control CV or VAV applications. The controls shall be factory-installed and mounted in the main control panel. All factory-installed controls shall be fully commissioned (run tested) at the factory.

The unit shall have a Human Interface Panel with a 16 key keypad, a 2 line X 40 character clear English display as standard to provide the operator with full adjustment and display of control data functions. The unit controls shall be used as a stand-alone controller, or as part of a building management system involving multiple units.

1. The unit shall be equipped with a complete microprocessor control system. This system shall consist of temperature and pressure (thermistor and transducer) sensors, printed circuit boards (modules), and a unit mounted Human Interface Panel. Modules (boards) shall be individually replaceable for ease of service. All microprocessors, boards and sensors shall be factory mounted, wired and tested.

The microprocessor boards shall be stand-alone DDC controls not dependent on communications with an on-site PC or a Building Management Network. The microprocessors shall be equipped with on-board diagnostics, indicating that all hardware, software and interconnecting wiring are in proper operating condition.

The modules (boards) shall be protected to prevent RFI and voltage transients from affecting the board's circuits. All field wiring shall be terminated at separate, clearly marked terminal strip.

Direct field wiring to the I/O boards is not acceptable. The microprocessor's memory shall be non-volatile EEPROM type requiring no battery or capacitive backup, while maintaining all data.

2. Zone sensors shall be available in several combinations with selectable features depending on sensor.
3. The Human Interface Panel's keypad display character format shall be 40 characters x 2 lines. The character font shall be 5 x 7 dot matrix plus cursor. The display shall be Supertwist Liquid Crystal Display (LCD) with blue characters on a gray/green background which provides high visibility and ease of interface. The display format shall be in clear English. Two or three digit coded displays are not acceptable.
4. The keypad shall be equipped with 16 individual touch-sensitive membrane key switches. The switches shall be divided into four separate sections and be password protected from change by unauthorized personnel. The six main menus shall be STATUS, SETPOINTS, DIAGNOSTICS, SETUP, CONFIGURATION and SERVICE MODE.

Filters

General

Filter options shall mount integral within unit and be accessible by hinged access panels.

Differential Pressure Gauge

A factory-installed, dial-type, differential pressure gauge shall be piped to both sides of the filter to indicate status. Gauge shall maintain a +/- 5 percent accuracy within operating temperature limits of -20°F to 120°F. Gauge shall be flush-mounted with casing outer wall. Filter sections consisting of pre- and post-filters shall have a gauge for each.

Mechanical Specifications

No Filters Option (two inch throwaway filter rack only)

Shall provide a complete set of two-inch thick filter racks, without the filter media to accommodate applications which require field supplied filters.

No Filters Option (bag/cartridge with prefilter filter rack)

Shall provide a long-lasting galvanized steel frame without the filter media to accommodate applications which require field supplied filters.

Pre-Evap Filter Options (Available for all units)

- **Throwaway Filters, MERV 4** — Filters are 2" [50.8 mm] thick, UL Class 2, glass fiber type. Filters rated at 80% average synthetic dust weight arrestance when tested in accordance with ASHRAE 52-76 and 52.1 test methods. Filters mounted in galvanized steel rack.
- **Permanent Cleanable Wire Mesh Option, MERV 3** — Shall be washable permanent wire mesh with metal frame.
- **High Efficiency Throwaway Option, MERV 8** — Shall be two-inch high efficiency media filters with average dust spot efficiency of 25-35 percent and an average arrestance in excess of 90 percent when tested in accordance with ASHRAE 52-76.
- **90-95 Percent Bag Filter Option, MERV 14** — Shall have glass fiber media mounted in a galvanized steel frame. These Class 1 single piece disposable bag filters shall have a 90-95% dust spot efficiency rating per ASHRAE 52-76. To ensure maximum bag filter life two-inch MERV 8 prefilters shall be included with the bag filters.
- **90-95 Percent Cartridge Filter Option, MERV 14** — Twelve-inch deep cartridge filters shall be mounted in a galvanized steel frame. Filters shall be Class 1 listed by Underwriters Laboratories and have a 90-95% dust spot efficiency per ASHRAE 52-76. To ensure maximum cartridge filter life, two-inch MERV 8 prefilters shall be provided.

Final Filter Options (Available for SX Units only)

Final filter section filter options shall mount integral within the blank section unit casing and be accessible by hinged access doors.

- **90-95 Percent, Cartridge, Final Filter Option, MERV 14** —

Note: Available on cooling only SX units

Twelve-inch deep cartridge filters shall be mounted in a galvanized steel frame. Filters shall be Class 1 listed by Underwriters Laboratories and have a 90-95% dust spot efficiency per ASHRAE 52-76.

- **90-95 Percent, Cartridge Filter with two-inch pre-filters, Final Filter Option, MERV 14** — Available on cooling only SX units

To ensure maximum cartridge filter life, 2" MERV 8 pre-filters shall be included with the cartridge filters. Pre-filters should be mounted in the same galvanized steel frame as the cartridge final filters.

Exhaust Air

General

Return air options shall include no relief, barometric relief, 50 percent exhaust fan, 100 percent modulating exhaust fan and 100 percent modulating exhaust fan with direct space building pressurization control. Exhaust motors are open drip-proof fan cooled. All 60 Hz motors meet the Energy Independence and Security Act of 2007 (EISA). All 50 Hz exhaust motors meet the U.S. Energy Policy Act of 1992 (EPACT).

No Relief (standard)

Rooftops can be built for makeup air applications with no exhaust. Relief air opening shall be sealed with panel and made watertight.

Barometric Relief Option

Gravity dampers shall open to relieve positive pressure in the return air section of the rooftop. Barometric relief dampers shall relieve building overpressurization, when that overpressurization is great enough to overcome the return duct pressure drops.

50 percent Exhaust Fan Option

One, double inlet, forward-curved fan shall be mounted rigidly to base with fixed sheave drive. Fan shall be dynamically balanced and tested in factory. Unit shall reach rated rpm before fan shaft passes through first critical speed. Fan shaft shall be mounted on two grease lubricated ball bearings designed for 200,000 hours average life. Optional extended grease lines shall allow greasing of bearings from unit filter section. Barometric dampers at fan outlet shall prevent air backdraft. Fifty percent exhaust fan shall be an on/off control based on economizer OA damper position.

Modulating 100 Percent Exhaust Fan Option

Two, double-inlet, forward-curved fans shall be mounted on a common shaft with fixed sheave drive. All fans shall be dynamically balanced and tested in factory before being installed in unit. Exhaust fan shall be test run in unit as part of unit test. Unit shall reach rated rpm before fan shaft passes through first critical speed. Fan shaft shall be mounted on two grease lubricated ball bearings designed for 200,000-hour average life.

Optional extended grease lines shall be provided to allow greasing of bearings from unit filter section. Fan motor and assembly shall be mounted on common base to allow consistent belt tension with no relative motion between fan and motor shafts. On motor sizes larger than five hp entire assembly shall be completely isolated from unit and fan board by double deflection, rubber in shear isolators or spring isolation. Discharge dampers at unit outlet shall modulate exhaust airflow in response to OA damper position.

Ultra Low Leak power exhaust dampers will be provided when the Ultra Low Leak Economizer is ordered. Ultra Low Leak power exhaust dampers will be AMCA 511 Class 1A certified with a maximum leakage rate of 3 CFM/sq-ft at 1.0 in WC pressure differential. This exceeds applicable requirements of ASHRAE 90.1 and IECC (4 CFM/sq-ft at 1.0 in WC pressure differential).

Modulating 100 Percent Exhaust Fan with Statitrac™ Control Option

Two, double-inlet, forward-curved fans shall be mounted on a common shaft with fixed sheave drive. All fans shall be dynamically balanced and tested in factory before being installed in unit. Exhaust fan shall be test run as part of unit final run test. Unit shall reach rated rpm before fan shaft passes through first critical speed.

Fan shaft shall be mounted on two grease lubricated ball bearings designed for 200,000-hour average life. Optional extended grease lines shall be provided to allow greasing of bearings from unit filter section. Fan motor and assembly shall be mounted on common base to allow consistent belt tension with no relative motion between fan and motor shafts. Entire assembly shall be completely isolated from unit and fan board by double deflection, rubber in shear isolators or spring isolation on motor sizes larger than five hp.

For both CV and VAV rooftops, the 100 percent modulating exhaust discharge dampers (or VFD) shall be modulated in response to building pressure. A differential pressure control system, (Statitrac™), shall use a differential pressure transducer to compare indoor building pressure to outdoor ambient atmospheric pressure. The FC exhaust fan shall be turned on when required to lower building static pressure setpoint.

The (Statitrac™) control system shall then modulate the discharge dampers (or VFD) to control the building pressure to within the adjustable, specified dead band that shall be adjustable at the Human Interface Panel.

Mechanical Specifications

Return Air

General

Return air options shall include 100 percent modulating return fan and 100 percent modulating return with direct space building pressurization control. All 60 Hz motors meet the Energy Independence and Security Act of 2007 (EISA). All 50 Hz exhaust motors meet the U.S. Energy Policy Act of 1992 (EPACT).

100 Percent Modulating Return Fan

A single width plenum fan with airfoil blade shall be mounted on a shaft with fixed sheave drive. The fan shall be dynamically balanced for the operating envelop and tested in factory before being installed in unit. The plenum fan shall be test run in unit as part of unit test. Fan operating envelop rpm shall be below first critical speed.

Fan shaft shall be mounted on two grease lubricated ball or roller bearings designed for 200,000-hour average life. Extended grease lines shall be provided to allow greasing of bearings from section base rail. Fan motor and assembly shall be mounted on common base to allow consistent belt tension with no relative motion between fan and motor shafts. The entire assembly shall be completely isolated from unit with 2-inch spring isolators. Discharge dampers at unit outlet shall modulate relief airflow in response to OA / return air damper position.

A single width plenum fan with airfoil blade can relieve up to 100 percent supply air. The fan operates in conjunction with the supply fan. The relief damper modulates in response to economizer damper position on Constant Volume rooftops.

Ultra Low Leak power exhaust dampers will be provided when the Ultra Low Leak Economizer is ordered. Ultra Low Leak power exhaust dampers will be AMCA 511 Class 1A certified with a maximum leakage rate of 3 CFM/sq-ft at 1.0 in WC pressure differential. This exceeds applicable requirements of ASHRAE 90.1 and IECC (4 CFM/sq-ft at 1.0 in WC pressure differential).

100 Percent Modulating Return Fan with Statitrac™ Control Option

A single width plenum fan with airfoil blade shall be mounted on a shaft with fixed sheave drive. The fan shall be dynamically balanced for the operating envelop and tested in factory before being installed in unit. The plenum fan shall be test run as part of unit final run test. Fan operating envelop rpm shall be below first critical speed.

Fan shaft shall be mounted on two grease lubricated ball or roller bearings designed for 200,000-hour average life. Extended grease lines shall be provided to allow greasing of bearings from section base rail. Fan motor and assembly shall be mounted on common base to allow consistent belt tension with no relative motion between fan and motor shafts. The entire assembly shall be completely isolated from unit with 2-inch spring isolators.

Option shall be provided with all the necessary controls to control/ maintain building space pressure through a VAV rooftop. The Variable Frequency Drive (VFD) modulates the speed of the return fan motor in response to return plenum pressure. The 100 percent modulating relief damper shall be modulated in response to building pressure. A differential pressure control system, (Statitrac), shall use a differential pressure transducer to compare indoor building pressure to outdoor ambient atmospheric pressure. The (Statitrac) control system shall modulate the dampers to control the building pressure to within the adjustable, specified deadband that shall be adjustable at the Human Interface Panel. The return fan shall modulate in response to return duct static pressure. Optional bypass control provides full nominal airflow in the event of drive failure.

Outside Air

General

Three outside air options: 100 percent return air, 0 to 25 percent manually controlled outside air, and 0-100 percent fully modulating economizer.

Manual Outside Air Option

Manually controlled outside air damper shall provide up to 25 percent outside air. Manual outside air damper shall be set at desired position at unit start-up.

0-100 Percent Modulating Economizer Option

Operated through the primary temperature controls to automatically utilize OA for "free" cooling. Automatically modulated return and OA dampers shall maintain proper temperature in the conditioned space. Economizer shall be equipped with an automatic lockout when the outdoor high ambient temperature is too high for proper cooling.

Minimum position control shall be standard and adjustable at the Human Interface Panel or with a remote potentiometer or through the building management system. A spring return motor shall ensure closure of OA dampers during unit shutdown or power interruption. Mechanical cooling shall be available to aid the economizer mode at any ambient. Standard economizer dampers leakage rate shall be 2.5 percent of nominal airflow (400 CFM/ton) at 1 inch wg. static pressure.

Low-Leak Economizer Dampers Option

Low leak dampers shall be provided with chlorinated polyvinyl chloride gasketing added to the damper blades and rolled stainless steel jamb seals to the sides of the damper assembly. Low leak economizer dampers shall have a leakage rate of one percent based on testing data completed in accordance with AMCA Standard 500 at AMCA Laboratories.

Ultra Low-Leak Economizer Dampers Option (20-75 Ton) & Design Special (90-130 Ton)

Economizer return and fresh air dampers shall be provided with horizontal airfoil blades and spring-return actuators. The economizer shall have a functional life of 60,000 opening and closing cycles. Dampers shall be AMCA 511 Class 1A certified with a maximum leakage rate of 3 CFM/sq-ft at 1.0 in WC pressure differential thus exceeding requirements of ASHRAE 90.1-2013, California Title 24-2013, and IECC-2012.

Fault Detection and Diagnostic (FDD) control will also be provided with Ultra Low Leak Economizers. FDD control monitors the commanded position of the economizer compared to the feedback position of the damper. If the damper position is outside +/- 10% of the commanded position, a diagnostic is generated.

Intellipak units ordered with Ultra Low Leak Economizers will be listed on the California Energy Commission Registry for factory compliance with Title 24 Economizer and FDD requirements. A label will be applied to the unit identifying construction with the Ultra Low Leak Economizer and FDD controls.

Economizer Control with Comparative Enthalpy

Used with the outside air economizer, two enthalpy sensors are provided to compare total heat content of the indoor air and outdoor air to determine the most efficient air source when economizing.

Economizer Control with Reference Enthalpy

Used with the outside air economizer, an outdoor enthalpy sensor is provided to compare the total heat content of outdoor air to a locally adjustable setpoint. The setpoint is programmed at the human interface, or remote human interface, to determine if the outdoor enthalpy condition is suitable for economizer operation.

Economizer Control with Dry Bulb

Used with the outside air economizer, an outdoor temperature sensor is included for comparing the outdoor dry bulb temperature to a locally adjustable temperature setpoint. The setpoint is programmed at the human interface, or remote human interface, to determine if outdoor air temperature is suitable for economizer operation.

Mechanical Specifications

Outside Air Measurement (Traq™)

A factory mounted airflow measurement station (Traq™) shall be provided in the outside air opening to measure airflow. The airflow measurement station shall measure from 40 cfm/ton to maximum airflow. The airflow measurement station shall adjust for temperature variations. Measurement accuracy shall meet requirements of LEED IE Q Credit 1 as defined by ASHRAE 62.1-2007.

Demand Control Ventilation

When equipped with a CO₂ sensor and the (VCM) module, the fresh air damper position shall modulate in response to a CO₂ sensor in the conditioned space, in order to minimize the unit energy consumption and simultaneously meet the ventilation requirements of ASHRAE Std 62.1. The Traq™ airflow monitoring solution augments the system, allowing for measurement and control of outside airflow.

Heating System

Electric Heating Option

All electric heat models shall be completely assembled and have wired electric heating system integral within the rooftop unit. Heavy duty nickel chromium elements internally wired with a maximum density of 40 watts per square inch shall be provided. Heater circuits shall be 48 amps or less, each individually fused. Automatic reset high limit control shall operate through heater backup contactors. The 460 and 575 volt electric units shall have optional factory mounted non-fused disconnect switch located in the main control panel to serve the entire unit.

The 200 and 230 volt SEHL models shall have separate power supply to heating section.

Steam Heating Option

Steam coils shall be Type NS, with non-freeze steam distribution circuits. Distributor tubes shall be located concentrically within condensing tubes to assure even steam distribution. Coils shall be pitched to provide complete drainage. Steam modulating valve with actuator shall be provided.

Hot Water Heating Option

Hot water coils shall be Type 5W and factory mounted in the rooftop unit to provide complete drainage of coil. Hot water modulating valve with actuator shall be provided.

Gas-Fired Heating Option

All gas-fired units shall be completely assembled and have a wired gas fired heating system integral within unit. Units shall be cULus approved specifically for outdoor applications downstream from refrigerant cooling coils. All gas piping shall be threaded connection with a pipe cap provided. Gas supply connection shall be provided through the side or bottom of unit. All units shall be fire tested prior to shipment.

- Heat Exchanger shall be tubular two pass design with stainless steel primary and secondary surfaces. Free floating design shall eliminate expansion and contraction stresses and noises. Gasketed cleanout plate shall be provided for cleaning of tubes/turbulators. Heat exchanger shall be factory pressure and leak tested.
- Burner shall be a stainless steel industrial type with an air proving switch to prevent burner operation if the burner is open for maintenance or inspection. Ceramic cone shall be provided to shape the flame to prevent impingement on sides of heat exchanger drum. Burner assembly shall house ignition and monitoring electrode.
- Combustion Blower shall be centrifugal type fan to provide air required for combustion. Fan motor shall have built-in thermal overload protection.
- Gas Safety Controls shall include electronic flame safety controls to require proving of combustion air prior to ignition sequence which shall include a 60 second pre-purge cycle. Direct spark ignition shall be provided on 235 and 350 MBh heat exchangers and pilot ignition

shall be provided on 500, 850 and 1000 MBh heat exchanger units. Sixty second delay shall be provided between first and second stage gas valve operation on two-stage heaters. Continuous electronic flame supervision shall be provided as standard.

- Full Modulation Gas Heaters shall be made from grades of stainless steel suitable for condensing situations. The heater shall have a turn down ratio of at least 4 to 1.
- Limited Modulation Gas Heaters shall have a minimum turn down ratio of at least 3 to 1.

Miscellaneous Options

- Ambient Control — Low Ambient Dampers are provided on condenser fan to allow the unit to operate down to 0°F (20-75 ton).
- Supply Airflow Measurement (Piezometer) — Plenum supply fan shall have an airflow measurement device to measure differential pressure and to calculate fan airflow. The device shall be capable of measuring airflow within ± 5 percent total accuracy when operating within the stable operating region of the fan curve. Fan airflow performance and noise levels shall not be affected by the installation of the device. The fan inlet shall not be obstructed by the airflow measurement device.
- IntelliPak™ Replacement Unit (IRU) — The IntelliPak™ replacement solution shall include a condenser base pan, strengthening of the condenser section with welded reinforcement of condenser base rail, as well as welded integral supports to the condenser base. This additional strength shall allow the reuse of the existing pedestal as well as any Trane full perimeter curb and reduce installation risk and labor. Also optional with stainless steel.
- Non-Fused Disconnect Switch with External Handle — External handle enables the operator to disconnect unit power with the control box door closed for safety.
- Hot Gas Bypass — Valve, piping and controls are all included on circuit 2 to allow operation at low airflow, avoiding coil frosting and damage to compressor. When suction pressure falls below valve adjustable setpoint, the valve modulates hot gas to the inlet of the evaporator.
- Modulating Hot Gas Reheat Dehumidification Control (available on S_HL units, air-cooled condenser only) — A reheat condenser coil is factory installed downstream of the unit evaporator coil. Modulating valves control the flow of refrigerant between the indoor reheat and outdoor condensers in response to the unit discharge air temperature in order to dehumidify the space. The modulating valve is always applied to circuit 1.
- Rapid Restart — Option shall provide immediate start-up upon power failure. A backup generator is required on site before unit start-up. Rapid Restart will begin immediately after recovery from a power loss and work by restarting the compressors and supply fan quickly, providing full cooling within two to three minutes.
- High Duct Temperature Thermostats — Two manual reset thermostats, one located in the discharge section of the unit set at 240°F and the other in the return section set at 135°F. The rooftop will shut down if the thermostats are tripped.
- High Efficiency Units (20-75 ton) — Unit shall meet ASHRAE 189.1-2011 and CEE Tier 2 Commercial Unitary AC and HP Specification for utility rebate requirements.
- High Capacity Units — Units are made high capacity through the use of larger compressors that provide higher refrigerant mass flow rates. All evaporative condensing units are high capacity units.
- Corrosion Protected Condenser Coil — All aluminum microchannel condenser coil protection shall consist of a corrosion resistant coating that shall withstand ASTM B117 Salt Spray test for 6,000 hours and ASTM G85 A2 Cyclic Acidified Salt Fog test for 2,400 hours. This coating shall be added after coil construction covering all tubes, headers and fin edges, therefore providing optimum protection in more corrosive environments.
- High Capacity Evaporator Coil — Additional rows of coil and enhanced evaporator tube surfaces provide increased capacity compared to standard coils. (90 and 105 ton)

Mechanical Specifications

- High Efficiency Condenser Coil — Additional rows of coil provide increased efficiency compared to standard coils. (90 ton)
- Internal Shaft Grounding Ring — Motors have internal bearing protection for use with VFDs to provide a conductive discharge path away from the motor bearings to ground. Bearing Protection Rings are circumferential rings with conductive micro fibers which provide the path of least resistance and dramatically extend motor life.
- Generic Building Automation System Module (GBAS 0-5 VDC) — Provided for those cases where non-Tracer building management system is used. The GBAS module provides a binary input for Demand Limiting, four (4) analog inputs for setpoint adjustment and five (5) relay outputs for diagnostic reporting. Inputs can use a potentiometer or 0-5 VDC signal.
- Generic Building Automation System Module (GBAS 0-10 VDC) — Used to provide broad control capabilities for building automation systems other than Trane's Tracer system. The GBAS module provides a binary input for Demand Limiting, four (4) analog inputs for setpoint adjustment and four (4) analog outputs as well as one (1) relay output for diagnostic reporting. Inputs can use a potentiometer or 0-10 VDC signal.
- Remote Human Interface Panel (RHI) — Remote Human Interface Panel can perform all the same functions as unit mounted Human Interface Panel, except for the Service Mode. Up to 4 rooftop units can be monitored and controlled with a single Remote Human Interface Panel.

This panel uses the same attractive enclosure as our Tracker™ building management system control panel. With features such as a 2 line X 40 character clear English display, a red LED light to indicate an alarm condition (alarm also shown on the two line display), a simple 16 key keypad that is used in conjunction with the display, to prompt the infrequent user when making desired changes and an attractive hinged door makes the RHI very suitable for mounting on any wall. The RHI can be mounted inside a building, up to 5,000 feet from the unit. The RHI is wired to the IPCB mounted in the rooftop with twisted wire pair communication wiring and 24V control wiring.
- Ventilation Override Module (VOM) — With the Ventilation Override Module installed, the unit can be programmed to transition to up to 5 different programmed sequences for Smoke Purge, Evacuation, Pressurization, Purge, Purge with duct control sequence and Unit off. The transition occurs when a binary input on the VOM is closed (shorted); this would typically be a hard wired relay output from a smoke detector or fire control panel
- Extended Grease Lines — Lines allow greasing of supply and exhaust fan bearings through the filter access door.
- Access Doors — Hinged access doors provide easy access to supply fan, filters, exhaust fan, and the heating section. These access doors feature double wall construction with dual density insulation sandwiched between heavy gauge galvanized steel panels for strength and durability.
- Inter-Processor Communication Bridge (IPCB) — This module provides an amplified and filtered version of the IPC link for connection to a Remote Human Interface Panel. Each rooftop that is tied into a Remote Human Interface Panel must have a IPCB installed into it.
- Trane Communication Interface Module — provides interface to Trane's Integrated Comfort system (ICS), which allows control and monitoring of the rooftop by a Tracer building management system.
- Tracer LonTalk® Communication Interface Module — provides control and monitoring of the rooftop by Tracer or to a 3rd party building management system utilizing LonTalk® protocol.
- BACnet Communication Interface Module — provides control and monitoring of the rooftop by Tracer SC or a 3rd party building management system utilizing BACnet protocol.
- GFI Convenience Outlet (Factory Powered) — A 15A, 115V Ground Fault Interrupter convenience outlet shall be factory installed. It shall be wired and powered from a factory mounted transformer. Unit mounted non-fused disconnect with external handle shall be furnished with factory powered outlet.

- Two-Inch Spring Isolators — Supply and exhaust fan (if applicable) assemblies are isolated with two-inch nominal deflection to reduce transmission of vibrations (standard feature on 90-130 tons).
- Special Unit Paint Colors — allows matching of HVAC equipment to building color and sometimes eliminates the need for expensive barrier walls

Accessories

Roof Mounting Curb

Roof mounting curb shall be heavy gauge zinc coated steel with nominal two-inch by four-inch nailer setup. Supply/return air opening gasketing shall be provided. Curb shall ship knocked down for easy assembly. Channel shall be provided to allow for adjustment of return air opening location. Curb shall be manufactured to National Roofing Contractors Association guidelines.

Electronic Zone Sensors

- Zone Sensors shall provide two temperature setpoint levers, Heat, Auto, Off, or Cool system switch, Fan Auto or Fan On switch. Optional status indication LED lights, System On, Heat, Cool, and Service shall be available. These sensors shall be used with CV units.
- Programmable Night Setback Sensors shall be electronic programmable sensors with auto or manual changeover with 7 day programming. Keyboard shall provide selection of Heat, Cool, Fan Auto or On. All programmable sensors shall have System On, Heat, Cool, Service LED/indicators as standard. Night setback sensors shall have (1) Occupied, (1) Unoccupied and (2) Override programs per day. Sensors shall be available for Zone Temperature Control and Supply Air Temperature Control.
- Discharge Temperature Control sensor shall be provided with supply air single temperature setpoint and AUTO/OFF system switch. Status indication LED lights shall include: System On, Heat, Cool and Service. Sensor shall be provided for zone temperature control for daytime warm-up heat mode.
- Remote Sensor shall be available to be used for remote zone temperature sensing capabilities when zone sensors are used as Remote panels.
- Fast Warm-Up Sensor shall be used as Morning warm-up sensor for Discharge Temperature Control units.
- Integrated Comfort System sensors shall be available with sensor only, sensor with timed override, and sensor with local temperature setpoint adjustment with timed override.
- Remote Minimum Position Potentiometer shall be available to remotely adjust the minimum position setting of the unit's economizer.
- Humidity Sensor - Monitors the humidity levels in the space for 1) Humidification and/or 2) Hot Gas Reheat Dehumidification.
- Temperature Sensor - bullet or pencil type sensor that could be used for temperature input such as return air duct temperature.

Field Installed Kits

- Trane Communication Interface/Interprocessor Communication Bridge kit and Remote Human Interface kit - For future opportunities and upgrade flexibility, two factory provided hardware kits are available. The Trane Communication Interface (TCI) module is required for communication with Tracer. Included in this kit is an Interprocessor Communicating Bridge (IPCB) module which is required for communication with a Remote Human Interface Panel.
- Remote Human Interface Panel kit - This kit can control up to four rooftops. The Remote Human Interface Panel has all the features of the Unit Mounted Human Interface Panel, except no service mode interface is allowed remotely for safety reasons. All other modules and their required hardware are available through the Trane service parts organization.
- Trane LonTalk® Communication Interface kit - For future opportunities and upgrade flexibility, this kit contains a LonTalk® Communication Interface (LCI-I) module, which is required for communication with Tracer Summit or a 3rd party building automation system.

Mechanical Specifications

- Trane BACnet Communication Interface kit - For future opportunities and upgrade flexibility, this kit contains a BACnet Communication Interface (BCI-I) module, which is required for communication with Tracer SC or a 3rd party building automation system
- Wireless Comm Interface (Field Installed) — Trane Wireless Comm interface provides wireless communication between the Tracer SC, Tracer Unit Controllers and BACnet Communication Interface (BCI) modules.

Note: *BCI required for operation*



Trane optimizes the performance of homes and buildings around the world. A business of Ingersoll Rand, the leader in creating and sustaining safe, comfortable and energy efficient environments, Trane offers a broad portfolio of advanced controls and HVAC systems, comprehensive building services, and parts. For more information, visit www.Trane.com.

Trane has a policy of continuous product and product data improvement and reserves the right to change design and specifications without notice.

