



Turn to the experts

## Product Data

# WeatherMaker® Single Packaged Rooftop Gas Heat/Electric Cooling

6 to 15 Nominal Tons



48TC 07, 08, 09, 12, 14, 16  
with Puron® (R-410A) Refrigerant

The 6 to 15 Ton WeatherMaker® Carrier rooftop unit (RTU) was designed by customers for customers. With “no-strip” screw collars, handled access panels, and more we’ve made your unit easy to install, easy to maintain and easy to use.

### Easy to install:

All WeatherMaker® units are field-convertible to horizontal air flow which makes it easy to adjust to unexpected job site complications. Lighter units make easy replacement. Most Carrier 48TC rooftops fit on existing Carrier curbs dating back to 1989. Also, our large control box gives you room to work and room to mount Carrier accessory controls.

### Easy to maintain:

Easy access handles by Carrier provide quick and easy access to all normally serviced components. Our “no-strip” screw system has superior holding power and guides screws into position while preventing the screw from stripping the unit’s metal.

### Easy to use:

The newly designed, central terminal board by Carrier puts all your connections and troubleshooting points in one convenient place, standard. Most low voltage connections are made to the same board and make it easy to find what you’re looking for and easy to access it. Carrier rooftops have high and low pressure switches, a filter drier, and 2-in. (51 mm) standard filters.

### Key features:

Key features are:

- Single circuit, single stage cooling model on 6 ton
- Single circuit, 2-stage cooling models are available from 7.5 to 10 ton.
- Dual circuit 2-stage cooling stage models are available from 7.5 to 15 ton.
- EERs up to 11.1 with IEERs up to 12.8
- Staged Air Volume (SAV™) 2-speed indoor fan motor system automatically adjusts the indoor fan motor speed between cooling stages. Standard on all 48TC\*D/E08-16 units for installation in the United States to meet the Department of Energy (DOE) efficiency standard of 2018. Factory option for all 48TC\*D/E08-16 unit installations outside the

United States. 48TC\*M08/09/12 units meet the DOE 2018 efficiency standard without the SAV option.

- Utility connections are the same because 6 to 12.5 ton units fit on existing Carrier rooftop curbs. This saves time and money on replacement jobs.
- Standardized components and layout. Standardized components and controls make service and stocking parts easier.
- Scroll compressors on all units. This makes service, stocking parts, replacement, and troubleshooting easier.
- Field convertible airflow (6 to 15 ton). Being able to convert a unit from vertical airflow to horizontal makes it easy to overcome job site complications. A 15 ton model requires a simple supply duct cover to field convert from factory vertical to horizontal.
- Easy-adjust, belt-drive motor available.
- Provisions for bottom or side condensate drain.
- Capable of thru-the-base or thru-the-curb gas line routing.
- Single-point gas / electrical connection.
- Internally sloped, composite drain pan sheds water; and won’t rust.
- Standardized controls and control box layout. Standardized components and controls make stocking parts and service easier.
- Tool-less filter access door.
- Clean, large, easy to use control box.
- Color-coded wiring.
- Large, laminated wiring and power wiring drawings which are affixed to unit make troubleshooting easy.
- Single, central terminal board for test and wiring connections.

- Fast-access, handled, panels for easy access on normally accessed service panels.
- “No-strip” screw system guides screws into the panel and captures them tightly without stripping the screw, the panel, or the unit.
- Mechanical cooling (115°F to 40°F or 46°C to 4°C) standard on all models. Winter Start Kit allows cooling operation down to 25°F (-4°C) and Motormaster® option to -20°F (-29°C).
- High efficiency, gas heat with induced-draft flue exhaust design.
- Induced draft motor ensures no flue gas can escape into the indoor air stream.
- Carrier designed naturally draining heat exchanger, unlike positive pressure heat exchangers, do not need to be periodically, manually drained. This saves labor and maintenance expense.
- 2-in. (51 mm) disposable filters on all units.
- Refrigerant filter-drier on each circuit.
- Each circuit is protected with a high and low pressure switch.
- Many factory-installed options ranging from air management economizers, 2 position dampers, plus convenience outlets, disconnect switches and smoke detectors.
- Standard (limited parts only) Warranty: 10 yr. aluminized heat exchanger, 5 yr. compressor, 3 yr. Novation® condenser coil, 1 yr. parts.
- Factory-installed Humidi-MiZer® adaptive dehumidification system on all sizes with round tube / plate fin condenser coils, includes Motormaster I controller.

## Table of contents

Features/Benefits . . . . .	2
Model Number Nomenclature . . . . .	3
AHRI Capacity Ratings . . . . .	4
Physical Data . . . . .	7
Options and Accessories . . . . .	12
Dimensions . . . . .	16
Performance Data . . . . .	33
Fan Data . . . . .	51
Electrical Data . . . . .	64
Typical Wiring Diagrams . . . . .	72
Sequence of Operation . . . . .	81
Application Data . . . . .	84
Guide Specifications . . . . .	86

## MODEL NUMBER NOMENCLATURE

Position:	1	2	3	4	5	6	7	8	9	10	11	12	13	14	15	16	17	18
Example:	4	8	T	C	D	D	0	8	A	1	A	5	-	0	A	0	G	0

### Unit Heat Type

48 - Gas Heat Packaged Rooftop

### Model Series - WeatherMaker®

TC - Standard Efficiency

### Heat Options

D = Low Heat  
 E = Medium Heat  
 F = High Heat  
 S = Low Heat w/ Stainless Steel Exchanger  
 R = Medium Heat w/ Stainless Steel Exchanger  
 T = High Heat w/ Stainless Steel Exchanger

### Refrig. Systems Options

A = One Stage Cooling Models (Size 07 Only)  
 B = One Stage Cooling Models with Humidi-MiZer® (Size 07 Only)  
 D = Two Stage Cooling Models 08-16  
 E = Two Stage Cooling Models 08-16 with Al/Cu condenser Coils and with Humidi-MiZer  
 M = Single Circuit, Two Stage Cooling Models (Sizes 08, 09, 12 Only)

### Cooling Tons

07 = 6 tons      12 = 10 tons  
 08 = 7.5 tons    14 = 12.5 tons  
 09 = 8.5 tons    16 = 15 tons

### Sensor Options

A = None  
 B = RA Smoke Detector  
 C = SA Smoke Detector  
 D = RA + SA Smoke Detector  
 E = CO<sub>2</sub>  
 F = RA Smoke Detector and CO<sub>2</sub>  
 G = SA Smoke Detector and CO<sub>2</sub>  
 H = RA + SA Smoke Detector and CO<sub>2</sub>  
 J = Condensate Overflow Switch (electro-mechanical controls only)  
 K = Condensate Overflow Switch and RA Smoke Detectors  
 L = Condensate Overflow Switch and RA and SA Smoke Detectors

### Indoor Fan Options

1 = Belt Drive, Standard Static Option  
 2 = Belt Drive, Medium Static Option  
 3 = Belt Drive, High Static Option\*  
 C = High Static Option with High Efficiency Motor (Size 16 Only)

### Coil Options – RTPF (Outdoor – Indoor – Hail Guard)

A = Al/Cu – Al/Cu  
 B = Precoat Al/Cu – Al/Cu  
 C = E-coat Al/Cu – Al/Cu  
 D = E-coat Al/Cu – E-coat Al/Cu  
 E = Cu/Cu – Al/Cu  
 F = Cu/Cu – Cu/Cu  
 M = Al/Cu – Al/Cu – Louvered Hail Guard  
 N = Precoat Al/Cu – Al/Cu – Louvered Hail Guard  
 P = E-coat Al/Cu – Al/Cu – Louvered Hail Guard  
 Q = E-coat Al/Cu – E-coat Al/Cu – Louvered Hail Guard  
 R = Cu/Cu – Al/Cu – Louvered Hail Guard  
 S = Cu/Cu – Cu/Cu – Louvered Hail Guard

### Coil Options – Novation® (Outdoor – Indoor – Hail Guard)

G = Al/Al – Al/Cu  
 H = Al/Al – Cu/Cu  
 J = Al/Al – E-coat Al/Cu  
 K = E-coat Al/Al – Al/Cu  
 L = E-coat Al/Al – E-coat Al/Cu  
 T = Al/Al – Al/Cu – Louvered Hail Guard  
 U = Al/Al – Cu/Cu – Louvered Hail Guard  
 V = Al/Al – E-coat Al/Cu – Louvered Hail Guard  
 W = E-coat Al/Al – Al/Cu – Louvered Hail Guard  
 X = E-coat Al/Al – E-coat Al/Cu – Louvered Hail Guard

### Packaging Compliance

0 = Standard  
 1 = LTL

### Electrical Options

#### Non USA Models — No SAV™ included

A = None  
 C = Non-Fused Disconnect  
 D = Thru-The-Base Connections  
 F = Non-Fused Disconnect and Thru-The-Base Connections

#### Standard USA Models — SAV included

G = 2-Speed Indoor Fan (VFD) Controller  
 J = 2-Speed Fan Controller (VFD) and Non-Fused Disconnect  
 K = 2-Speed Fan Controller (VFD) and Thru-The-Base Connections  
 M = 2-Speed Fan Controller (VFD) with Non-Fused Disconnect and Thru-The-Base Connections

### Service Options

0 = None  
 1 = Unpowered Convenience Outlet  
 2 = Powered Convenience Outlet  
 3 = Hinged Panels  
 4 = Hinged Panels and Unpowered Convenience Outlet  
 5 = Hinged Panels and Powered Convenience Outlet

### Intake / Exhaust Options

A = None  
 B = Temperature Economizer w/ Barometric Relief  
 F = Enthalpy Economizer w/ Barometric Relief  
 K = 2-Position Damper  
 U = Temperature Ultra Low Leak Economizer w/ Barometric Relief  
 W = Enthalpy Ultra Low Leak Economizer w/ Barometric Relief

### Base Unit Controls

0 = Electro-mechanical Controls can be used with W7212 EconoMiSer® IV (Non-Fault Detection and Diagnostic)  
 1 = PremierLink™ Controller  
 2 = RTU Open Multi-Protocol Controller  
 6 = Electro-mechanical w/ 2-Speed Fan and W7220 Economizer Controller Controls. Can be used with W7220 EconoMiSer X (w/ Fault Detection and Diagnostic)

### Design Revision

- = Factory Design Revision

### Voltage

1 = 575/3/60  
 5 = 208-230/3  
 6 = 460/3/60

\*Not available for 48TC\*M08 units.

**NOTE:** Not all possible options are displayed, see the current 48TC 6 to 15 Ton Price Pages for more details.

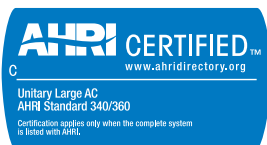

## AHRI COOLING RATINGS

48TC UNIT	COOLING STAGES	REFRIGERANT CIRCUITS	NOM. CAPACITY (TONS)	NET COOLING CAPACITY (MBH)	TOTAL POWER (KW)	EER	IEER WITH SINGLE SPEED INDOOR FAN MOTOR	IEER WITH 2-SPEED INDOOR FAN MOTOR
A07	1	1	6.0	70.0	6.4	11.00	11.2	12.7
D08	2	2	7.5	83.0	7.5	11.00	11.7	12.8
D09	2	2	8.5	99.0	9.0	11.00	11.7	12.8
D12	2	2	10.4	114.0	10.3	11.00	11.8	12.8
D14	2	2	12.5	140.0	12.9	10.80	11.0	12.2
D16	2	2	15.0	174.0	16.1	10.80	11.5	12.4
M08*	2	1	7.5	88.0	8.0	11.00	12.7	N/A
M09	2	1	8.5	97.0	8.8	11.00	12.7	N/A
M12	2	1	10.0	117.0	10.6	11.00	12.7	N/A

### LEGEND

- AHRI** — Air-Conditioning, Heating and Refrigeration Institute Test Standard  
**ASHRAE** — American Society of Heating, Refrigerating and Air-Conditioning Engineers  
**EER** — Energy Efficiency Ratio  
**IEER** — Integrated Energy Efficiency Ratio  
**IECC<sup>1</sup>** — International Energy Conservation Code  
**N/A** — Not Applicable

\* High static fan is not available on M08 units.

### NOTES:

1. Rated and certified under AHRI Standard 340/360, as appropriate.
2. Ratings are based on:  
**Cooling Standard:** 80°F (27°C) db, 67°F (19°C) wb indoor.  
**IEER Standard:** A measure that expresses cooling part load EER efficiency for commercial unitary air conditioning and heat pump equipment on the basis of weighted operation at various load capacities.
3. The 48TC\*D rooftops meets the DOE-2018 (Department of Energy), ASHRAE 90.1-2016 and IECC<sup>1</sup>-2015 minimum efficiency requirements when equipped with the SAV™ (staged air volume) option.
4. The 48TC\*M rooftops meet the DOE-2018 minimum efficiency requirement without the SAV option.



1. IECC is a registered trademark of International Code Council, Inc



### HEATING RATING TABLE - NATURAL GAS AND PROPANE

48TC UNITS	GAS HEAT	AL/SS HEAT EXCHANGER		TEMP RISE (DEG F)	THERMAL EFFICIENCY (%)
		INPUT / OUTPUT STAGE 1 (MBH)	INPUT / OUTPUT STAGE 2 (MBH)		
07	LOW	—	72 / 59	15 – 55	82%
	MED	—	115 / 93	25 – 65	81%
	HIGH	120 / 96	150 / 120	35 – 80	80%
08	LOW	—	125 / 103	20 – 50	82%
	MED	120 / 98	180 / 148	35 – 65	82%
	HIGH	180 / 147	224 / 184	45 – 75	82%
09	LOW	—	125 / 103	20 – 50	82%
	MED	120 / 98	180 / 148	30 – 65	82%
	HIGH	180 / 147	224 / 184	40 – 75	82%
12	LOW	120 / 98	180 / 148	25 – 65	82%
	MED	180 / 147	224 / 184	30 – 65	82%
	HIGH	200 / 160	250 / 205	35 – 70	80%
14	LOW	120 / 98	180 / 148	20 – 65	82%
	MED	180 / 147	224 / 184	25 – 65	82%
	HIGH	200 / 160	250 / 205	25 – 70	80%
16	LOW	144 / 118	180 / 146	15 – 55	81%
	MED	192 / 156	240 / 195	20 – 60	81%
	HIGH	280 / 224	350 / 280	35 – 65	80%

**NOTES:**

- Heat ratings are for natural gas heat exchangers operated at or below 2000 ft (610 m). For information on propane or altitudes above 2000 ft (610 m), see the Application Data section of this book. Accessory Propane/High Altitude kits are also available.
- The input rating for altitudes above 2000 ft (610 m) must be derated by 4% for each 1000 ft (305 m) above sea level.

### SOUND PERFORMANCE

48TC UNIT	COOLING STAGES	OUTDOOR SOUND (dB) AT 60 Hz								
		A-Weighted	63	125	250	500	1000	2000	4000	8000
A07	1	78	88.8	81.8	76.9	74.4	73.3	69.8	66.3	62.7
M08	2	82	90.1	82.6	81.0	79.4	77.0	73.0	70.4	66.7
D08	2	82	85.8	84.3	80.5	78.7	76.4	72.7	68.3	65.1
M09	2	83	91.2	86.4	81.9	81.0	78.3	73.9	71.4	67.3
D09	2	82	88.6	85.0	81.6	79.5	77.4	74.1	71.0	66.3
M12	2	82	88.6	85.0	81.6	79.5	77.4	74.1	71.0	66.3
D12	2	82	89.0	83.1	80.5	78.5	75.5	71.6	69.6	69.3
D14	2	87	87.0	85.2	84.6	84.9	82.2	78.4	75.3	72.9
D16	2	87	87.0	85.2	84.6	84.9	82.2	78.4	75.3	72.9

**LEGEND**

**dB** — Decibel

**NOTES:**

- Outdoor sound data is measured in accordance with AHRI standard 270.
- Measurements are expressed in terms of sound power. Do not compare these values to sound pressure values because sound

pressure depends on specific environmental factors which normally do not match individual applications. Sound power values are independent of the environment and therefore more accurate.

- A-weighted sound ratings filter out very high and very low frequencies, to better approximate the response of “average” human ear. A-weighted measurements for Carrier units are taken in accordance with AHRI standard 270.

# AHRI capacity ratings (cont)



## MINIMUM - MAXIMUM AIRFLOW (CFM) RATINGS - NATURAL GAS AND PROPANE

UNIT	HEAT LEVEL	COOLING				AL HX HEATING		SS HX HEATING	
		Minimum	Minimum 2-Speed Fan Motor (at High Speed)	Minimum 2-Speed Fan Motor (at Low Speed)	Maximum	Minimum	Maximum	Minimum	Maximum
48TC**07	LOW	1800	1800	1200	3000	990	3640	990	3640
	MED					1330	3450	1330	3450
	HIGH					1390	3170	1390	3170
48TC**08	LOW	2250	2250	1500	3750	1900	4750	1900	4750
	MED					2100	3900	2100	3900
	HIGH					2270	3780	2270	3780
48TC**09	LOW	2550	2873	1915	4250	1900	4750	1900	4750
	MED					2100	4560	2100	4560
	HIGH					2270	4250	2270	4250
48TC**12	LOW	3000	3380	2253	5000	2100	5470	2100	5470
	MED					2620	5670	2620	5670
	HIGH					2650	5290	2650	5290
48TC**14	LOW	3600	4056	2704	6000	2100	6830	2100	6830
	MED					2620	6800	2620	6800
	HIGH					2650	7410	2650	7410
48TC**16	LOW	4500	5625	3750	7500	2450	7500	2450	9000
	MED					3000	6750	3000	9000
	HIGH					3990	7200	3990	7410

**LEGEND**

**AL HX**— Aluminum Gas Heat Exchanger

**SS HX**— Stainless Steel Gas Heat Exchanger

## PHYSICAL DATA (COOLING) — 6 TONS

UNIT		48TC-A07
<b>REFRIGERATION SYSTEM</b>		
	# Circuits / # Comp. / Type	1 / 1 / Scroll
	Puron® refig. (R-410A)(lbs-oz)	14 - 2
	Humidi-Mizer® Puron® refig. charge A/B (lbs-oz)	22 - 5
	Metering device	Accutrol*
	Humidi-Mizer Metering Device	Accutrol + TXV
	High-press. Trip / Reset (psig)	630 / 505
	Low-press. Trip / Reset (psig)	54 / 117
	Compressor Capacity Staging (%)	100%
<b>EVAP. COIL</b>		
	Material	Cu / Al
	Coil Type (Tube Dia.)	3/8-in. RTPF
	Rows / FPI	4 / 15
	Total face area (ft²)	7.3
	Condensate drain conn. size	3/4-in.
<b>HUMIDI-MIZER® COIL</b>		
	Material	Cu / Al
	Coil Type (Tube Dia.)	3/8-in. RTPF
	Rows / FPI	2 / 17
	Total face area (ft²)	5.2
<b>EVAPORATOR FAN AND MOTOR</b>		
<b>Standard Static</b>	Motor Qty. / Driver Type	1 / Belt
	Max BHP	2.4
	RPM range	1073-1457
	Motor frame size	56
	Fan Qty. / Type	1 / Centrifugal
	Fan Diameter (in.)	10 x 10
<b>Medium Static</b>	Motor Qty. / Driver Type	1 / Belt
	Max BHP	2.9†
	RPM range	1173-1518
	Motor frame size	56
	Fan Qty. / Type	1 / Centrifugal
	Fan Diameter (in.)	10 x 10
<b>High Static</b>	Motor Qty. / Driver Type	1 / Belt
	Max BHP	3.7
	RPM range	1474-1788
	Motor frame size	56
	Fan Qty. / Type	1 / Centrifugal
	Fan Diameter (in.)	10 x 10
<b>CONDENSER COIL</b>		
	Material (Tube/Fin)	Cu / Al
	Coil Type	3/8-in. RTPF
	Rows / FPI	2 / 17
	Total Face Area (ft²)	21.3
<b>COND. FAN / MOTOR</b>		
	Qty / Motor Drive Type	1 / Direct
	Motor HP / RPM	1/4 / 1100
	Fan diameter (in.)	22
<b>FILTERS</b>		
	RA Filter # / Size (in.)	4 / 16 x 16 x 2
	OA inlet screen # / Size (in.)	1 / 20 x 24 x 1

\* Accutrol is a trademark of Accutrol LLC.

† 575V motor utilizes 3.7 BHP.

NOTE: Humidi-MiZer® is not available with Novation® condenser coil models, only Round Tube / Plate Fin (RTPF).



## PHYSICAL DATA (COOLING) — 7.5-8.5 TONS

UNIT		48TC-D08	48TC-M08	48TC-D09	48TC-M09
<b>REFRIGERATION SYSTEM</b>					
# Circuits / # Comp. / Type		2 / 2 / Scroll	1 / 1 / 2-Stage Scroll	2 / 2 / Scroll	1 / 1 / 2-Stage Scroll
RTPF models R410A charge A/B (lbs-oz)		8-5 / 8-2	12-0	10-5 / 10-12	15-5
Alternate (MCHX) R410A charge A/B (lbs-oz)		4-6 / 4-6	—	—	—
Alternate (Humidi-MiZer®) R-410A charge A/B (lbs-oz)		13-3 / 13-3	—	16-13 / 16-13	—
Metering device		Accutrol	Accutrol + TXV	Accutrol	Accutrol + TXV
Alternate Humidi-Mizer Metering Device		Accutrol + TXV	—	Accutrol + TXV	—
High-press. Trip / Reset (psig)		630 / 505	630 / 505	630 / 505	630 / 505
Low-press. Trip / Reset (psig)		54 / 117	54 / 117	54 / 117	54 / 117
Compressor Capacity Staging (%)		50% / 100%	66% / 100%	50% / 100%	66% / 100%
<b>EVAP. COIL</b>					
Material		Cu / Al	Cu / Al	Cu / Al	Cu / Al
Coil Type (Tube Dia.)		3/8-in. RTPF	3/8-in. RTPF	3/8-in. RTPF	3/8-in. RTPF
Rows / FPI		3 / 15	3 / 15	3 / 15	3 / 15
Total face area (ft <sup>2</sup> )		8.9	8.9	11.1	11.1
Condensate drain conn. size		3/4-in.	3/4-in.	3/4-in.	3/4-in.
<b>HUMIDI-MIZER® COIL</b>					
Material		Cu / Al	—	Cu / Al	—
Coil Type (Tube Dia.)		3/8-in. RTPF	—	3/8-in. RTPF	—
Rows / FPI		2 / 17	—	2 / 17	—
Total face area (ft <sup>2</sup> )		3.9	—	5.2	—
<b>EVAPORATOR FAN AND MOTOR</b>					
<b>Standard Static</b>	Motor Qty. / Driver Type	1 / Belt	1 / Belt	1 / Belt	1 / Belt
	Max BHP	1.7	1.7	1.7	1.7
	RPM range	489-747	489-747	518-733	518-733
	Motor frame size	56	56	56	56
	Fan Qty. / Type	1 / Centrifugal	1 / Centrifugal	1 / Centrifugal	1 / Centrifugal
	Fan Diameter (in.)	15 x 15	15 x 15	15 x 15	15 x 15
<b>Medium Static</b>	Motor Qty. / Driver Type	1 / Belt	1 / Belt	1 / Belt	1 / Belt
	Max BHP	2.9*	2.9*	2.9	2.4
	RPM range	733-949	733-949	690-936	690-936
	Motor frame size	56	56	56	56
	Fan Qty. / Type	1 / Centrifugal	1 / Centrifugal	1 / Centrifugal	1 / Centrifugal
	Fan Diameter (in.)	15 x 15	15 x 15	15 x 15	15 x 15
<b>High Static</b>	Motor Qty. / Driver Type	1 / Belt	—	1 / Belt	1 / Belt
	Max BHP	4.7	—	3.7	3.7
	RPM range	909-1102	—	838-1084	838-1084
	Motor frame size	14	—	56	56
	Fan Qty. / Type	1 / Centrifugal	—	1 / Centrifugal	1 / Centrifugal
	Fan Diameter (in.)	15 x 15	—	15 x 15	15 x 15
<b>CONDENSER COIL</b>					
Material (Tube/Fin)		Cu / Al	Cu / Al	Cu / Al	Cu / Al
Coil type		3/8-in. RTPF	5/16-in. RTPF	3/8-in. RTPF	3/8-in. RTPF
Rows / FPI		2 / 17	2 / 18	2 / 17	2 / 17
Total Face Area (ft <sup>2</sup> )		20.5	20.5	25.1	21.4
<b>ALTERNATE (MCHX) CONDENSER COIL</b>					
Material (Tube/Fin)		Al / Al	—	—	—
Coil type		Novation®	—	—	—
Rows / FPI		1 / 20	—	—	—
Total Face Area (ft <sup>2</sup> )		20.5	—	—	—
<b>COND. FAN / MOTOR</b>					
Qty / Motor Drive Type		2 / Direct	2 / Direct	2 / Direct	2 / Direct
Motor HP / RPM		1/4 / 1100	1/4 / 1100	1/4 / 1100	1/4 / 1100
Fan diameter (in.)		22	22	22	22
<b>FILTERS</b>					
RA Filter # / Size (in.)		4 / 16 x 20 x 2	4 / 16 x 20 x 2	4 / 20 x 20 x 2	4 / 20 x 20 x 2
OA inlet screen # / Size (in.)		1 / 20 x 24 x 1	1 / 20 x 24 x 1	1 / 20 x 24 x 1	1 / 20 x 24 x 1

### LEGEND

— Not applicable

\* 575V motor utilizes 3.7 BHP.

NOTE: Humidi-MiZer® is not available with Novation® condenser coil models, only Round Tube / Plate Fin (RTPF).





### PHYSICAL DATA (COOLING) — 10-15 TONS

UNIT		48TC-D/E12	48TC-M12	48TC-D/E14	48TC-D/E16
<b>REFRIGERATION SYSTEM</b>					
# Circuits / # Comp. / Type		2 / 2 / Scroll	1 / 1 / 2-Stage Scroll	2 / 2 / Scroll	2 / 2 / Scroll
RTPF models R410A charge A/B (lbs-oz)		10-5 / 10-3	21-0	11-0 / 11-6	15-14 / 16-12
Alternate (MCHX) R410A charge A/B (lbs-oz)		6-0 / 6-0	—	7-6 / 8-0	—
Alternate (Humidi-MiZer®) R410A charge A/B (lbs-oz)		16-10 / 16-0	—	17-10 / 18-3	—
Metering device		Accutrol	Accutrol + TXV	Accutrol	Accutrol
Alternate Humidi-Mizer Metering Device		Accutrol + TXV	—	Accutrol + TXV	—
High-press. Trip / Reset (psig)		630 / 505	630 / 505	630 / 505	630 / 505
Low-press. Trip / Reset (psig)		54 / 117	54 / 117	54 / 117	54 / 117
Compressor Capacity Staging (%)		50% / 100%	66% / 100%	50% / 100%	50% / 100%
<b>EVAP. COIL</b>					
Material		Cu / Al	Cu / Al	Cu / Al	Cu / Al
Coil Type (Tube Dia.)		3/8-in. RTPF	3/8-in. RTPF	3/8-in. RTPF	3/8-in. RTPF
Rows / FPI		4 / 15	4 / 15	4 / 15	3 / 15
Total face area (ft²)		11.1	11.1	11.1	17.5
Condensate drain conn. size		3/4-in.	3/4-in.	3/4-in.	3/4-in.
<b>HUMIDI-MIZER® COIL</b>					
Material		Cu / Al	—	Cu / Al	Cu / Al
Coil Type (Tube Dia.)		3/8-in. RTPF	—	3/8-in. RTPF	3/8-in. RTPF
Rows / FPI		2 / 17	—	2 / 17	2 / 17
Total face area (ft²)		8.4	—	8.4	13.8
<b>EVAPORATOR FAN AND MOTOR</b>					
<b>Standard Static</b>	Motor Qty. / Driver Type	1 / Belt	1 / Belt	1 / Belt	1 / Belt
	Max BHP	2.4	2.4	2.9*	2.9*
	RPM range	591-838	591-838	652-843	507-676
	Motor frame size	56	56	56	56
	Fan Qty. / Type	1 / Centrifugal	1 / Centrifugal	1 / Centrifugal	1 / Centrifugal
<b>Medium Static</b>	Motor Qty. / Driver Type	1 / Belt	1 / Belt	1 / Belt	1 / Belt
	Max BHP	3.7	3.7	3.7	3.7
	RPM range	838-1084	838-1084	838-1084	627-851
	Motor frame size	56	56	56	56
	Fan Qty. / Type	1 / Centrifugal	1 / Centrifugal	1 / Centrifugal	1 / Centrifugal
<b>High Static</b>	Motor Qty. / Driver Type	1 / Belt	1 / Belt	1 / Belt	1 / Belt
	Max BHP	4.7	4.7	4.7	6.5 / 6.9 / 7.0 / 8.3†
	RPM range	1022-1240	1022-1240	1022-1240	776-955
	Motor frame size	14	14	14	S184T
	Fan Qty. / Type	1 / Centrifugal	1 / Centrifugal	1 / Centrifugal	1 / Centrifugal
CONDENSER COIL					
Material (Tube/Fin)		Cu / Al	Cu / Al	Cu / Al	Cu / Al
Coil Type		3/8-in. RTPF	3/8-in. RTPF	3/8-in. RTPF	3/8-in. RTPF
Rows / FPI		2 / 17	2 / 17	3 / 17	2 / 17
Total Face Area (ft²)		25.1	25.1	25.1	2@23.1
<b>ALTERNATE (MCHX) CONDENSER COIL</b>					
Material (Tube/Fin)		Al / Al	—	Al / Al	—
Coil Type		Novation®	—	Novation®	—
Rows / FPI		1 / 20	—	1 / 20	—
Total Face Area (ft²)		25.1	—	25.1	—
<b>COND. FAN / MOTOR</b>					
Qty / Motor Drive Type		2 / Direct	2 / Direct	1 / Direct	3 / Direct
Motor HP / RPM		1/4 / 1100	1/4 / 1100	1/4 / 1175	1/4 / 1100
Fan diameter (in.)		22	22	30	22
<b>FILTERS</b>					
RA Filter # / Size (in.)		4 / 20 x 20 x 2	4 / 20 x 20 x 2	4 / 20 x 20 x 2	6 / 18 x 24 x 2
OA inlet screen # / Size (in.)		1 / 20 x 24 x 1	1 / 20 x 24 x 1	1 / 20 x 24 x 1	2 / 24 x 27 x 1 (vert.) 1 / 30 x 39 x 1 (horiz.)

**LEGEND**

- Not applicable
- \* 575V motor utilizes 3.7 BHP.
- † On size 16 units, Max BHP for the High Static motor varies with the motor's voltage; see the Voltage/BHP table to the right.

NOTE: Humidi-MiZer® is not available with Novation® condenser coil models, only Round Tube / Plate Fin (RTPF) up to size 16.

Voltage	BHP
208	6.5
230	6.9
460	7.0
575	8.3

## PHYSICAL DATA (HEATING) — 6-10 TONS

UNIT		48TC**07	48TC**08	48TC**09	48TC**12
<b>GAS CONNECTION</b>					
# of Gas Valves		1	1	1	1
Natural Gas supply line press. (in. wg) /(PSIG)		4-13 / 0.18-0.47	4-13 / 0.18-0.47	4-13 / 0.18-0.47	4-13 / 0.18-0.47
LP supply line press. (in. wg) /(PSIG)		11-13 / 0.040-0.047	11-13 / 0.040-0.047	11-13 / 0.040-0.047	11-13 / 0.040-0.047
<b>HEAT ANTICIPATOR SETTING (AMPS)</b>					
First stage		0.14	0.14	0.14	0.14
Second stage		0.14	0.14	0.14	0.14
<b>NATURAL GAS HEAT</b>					
<b>LOW</b>	# of Stages / # of Burners (Total)	1 / 2	1 / 2	1 / 3	2 / 4
	Connection Size	1/2-in. NPT	1/2-in. NPT	1/2-in. NPT	3/4-in. NPT
	Rollout switch opens / closes	195 / 115	195 / 115	195 / 115	195 / 115
	Temperature Rise	15 - 55	20 - 50	20 - 50	25 - 65
<b>MEDIUM</b>	# of Stages / # of Burners (Total)	1 / 3	2 / 4	2 / 4	2 / 5
	Connection Size	1/2-in. NPT	3/4-in. NPT	3/4-in. NPT	3/4-in. NPT
	Rollout switch opens / closes	195 / 115	195 / 115	195 / 115	195 / 115
	Temperature Rise	25 - 65	35 - 65	30 - 65	30 - 65
<b>HIGH</b>	# of Stages / # of Burners (Total)	2 / 3	2 / 5	2 / 5	2 / 5
	Connection Size	1/2-in. NPT	3/4-in. NPT	3/4-in. NPT	3/4-in. NPT
	Rollout switch opens / closes	195 / 115	195 / 115	195 / 115	195 / 115
	Temperature Rise	35 - 80	45 - 75	40 - 75	35 - 70
<b>LIQUID PROPANE HEAT</b>					
<b>LOW</b>	# of Stages / # of Burners (Total)	1 / 2	1 / 3	1 / 3	2 / 4
	Connection Size	1/2-in. NPT	1/2-in. NPT	1/2-in. NPT	3/4-in. NPT
	Rollout switch opens / closes	195 / 115	195 / 115	195 / 115	195 / 115
	Temperature Rise	15 - 55	20 - 50	20 - 50	20 - 65
<b>MEDIUM</b>	# of Stages / # of Burners (Total)	1 / 3	2 / 4	2 / 4	2 / 5
	Connection Size	1/2-in. NPT	1/2-in. NPT	1/2-in. NPT	1/2-in. NPT
	Rollout switch opens / closes	195 / 115	195 / 115	195 / 115	195 / 115
	Temperature Rise	25 - 65	35 - 65	30 - 65	30 - 65
<b>HIGH</b>	# of Stages / # of Burners (Total)	2 / 3	2 / 5	2 / 5	2 / 5
	Connection Size	1/2-in. NPT	3/4-in. NPT	3/4-in. NPT	3/4-in. NPT
	Rollout switch opens / closes	195 / 115	195 / 115	195 / 115	195 / 115
	Temperature Rise	35 - 80	45 - 75	45 - 75	35 - 70



**PHYSICAL DATA (HEATING) — 12.5-15 TONS**

UNIT		48TC**14	48TC**16
<b>GAS CONNECTION</b>			
	# of Gas Valves	1	1
	Natural Gas supply line press. (in. wg) /(PSIG)	4-13 / 0.18-0.47	5-13 / 0.18-0.47
	LP supply line press. (in. wg) /(PSIG)	11-13 / 0.040-0.047	11-13 / 0.040-0.047
<b>HEAT ANTICIPATOR SETTING (AMPS)</b>			
	First stage	0.14	0.14
	Second stage	0.14	0.14
<b>NATURAL GAS HEAT</b>			
<b>LOW</b>	# of Stages / # of Burners (Total)	2 / 4	2 / 6
	Connection Size	3/4-in. NPT	3/4-in. NPT
	Rollout switch opens / closes	195 / 115	225 / 145
	Temperature Rise	25 - 65	20 - 55
<b>MEDIUM</b>	# of Stages / # of Burners (Total)	2 / 5	2 / 8
	Connection Size	3/4" NPT	3/4" NPT
	Rollout switch opens / closes	195 / 115	225 / 145
	Temperature Rise	30 - 65	25 - 60
<b>HIGH</b>	# of Stages / # of Burners (Total)	2 / 5	2 / 10
	Connection Size	3/4-in. NPT	3/4-in. NPT
	Rollout switch opens / closes	195 / 115	225 / 145
	Temperature Rise	35 - 70	35 - 65
<b>LIQUID PROPANE HEAT</b>			
<b>LOW</b>	# of Stages / # of Burners (Total)	2 / 4	2 / 6
	Connection Size	3/4-in. NPT	3/4-in. NPT
	Rollout switch opens / closes	195 / 115	225 / 145
	Temperature Rise	25 - 65	20 - 55
<b>MEDIUM</b>	# of Stages / # of Burners (Total)	2 / 5	2 / 8
	Connection Size	3/4-in. NPT	3/4-in. NPT
	Rollout switch opens / closes	195 / 115	225 / 145
	Temperature Rise	35 - 65	25 - 60
<b>HIGH</b>	# of Stages / # of Burners (Total)	2 / 5	2 / 10
	Connection Size	3/4-in. NPT	3/4-in. NPT
	Rollout switch opens / closes	195 / 115	225 / 145
	Temperature Rise	35 - 70	35 - 65

## FACTORY-INSTALLED AND FIELD-INSTALLED ACCESSORIES

CATEGORY	ITEM	FACTORY-INSTALLED OPTION	FIELD-INSTALLED ACCESSORY
<b>Cabinet</b>	Thru-the- base electrical or gas- line connections	X	X
	Supply Duct Cover (16 size only)		X
	Hinged Access Panels	X	
<b>Coil Options</b>	Cu/Cu indoor and/or outdoor coils <sup>1</sup>	X	
	Pre-coated outdoor coils <sup>1</sup>	X	
	Premium, E- coated outdoor coils <sup>1</sup>	X	
<b>Humidity Control</b>	Humidi-MiZer® Adaptive Dehumidification System	X	
<b>Condenser Protection</b>	Condenser coil hail guard (louvered design)	X	X
<b>Controls</b>	Thermostats, temperature sensors, and subbases		X
	PremierLink™ DDC communicating controller <sup>8</sup>	X	X
	RTU Open –multi-protocol controller	X	
	Smoke detector (supply and/or return air)	X	
	Horn/Strobe Annunciator <sup>10</sup>		X
	Time Guard II compressor delay control circuit		X
	Phase Monitor		X
	Condensate overflow switch	X	X
<b>Economizers and Outdoor Air Dampers</b>	EconoMi\$er® IV for electro-mechanical controls – Non FDD (Low air leak damper models) <sup>6</sup>	X	X
	EconoMi\$er2 for DDC controls, complies with FDD (Low Leak and Ultra Low Leak air damper models) <sup>7,8</sup>	X	X
	Motorized 2 position outdoor air damper <sup>8</sup>	X	X
	Manual outdoor air damper (25% and 50%) <sup>8</sup>		X
	Barometric relief <sup>2</sup>	X	X
	Power exhaust		X
	EconoMi\$er X for electro-mechanical controls, complies with FDD. (Low Leak and Ultra Low Leak air damper models) <sup>6</sup>	X	X
<b>Economizer Sensors and IAQ Devices</b>	Single dry bulb temperature sensors <sup>3</sup>	X	X
	Differential dry bulb temperature sensors <sup>3</sup>		X
	Single enthalpy sensors <sup>3</sup>	X	X
	Differential enthalpy sensors <sup>3</sup>		X
	Wall or duct mounted CO <sub>2</sub> sensor <sup>3</sup>		X
	Unit mounted CO <sub>2</sub> sensor <sup>3</sup>	X	
<b>Gas Heat</b>	Propane conversion kit		X
	Stainless steel heat exchanger	X	
	High altitude conversion kit		X
	Flue Shield (07-14 sizes only)		X
	Flue Discharge Deflector		X
<b>Indoor Motor and Drive</b>	Multiple motor and drive packages	X	
	Staged Air Volume (SAV™) system w/VFD controller (2-stage cool only with electro-mechanical and RTU Open controls) <sup>9</sup>	X	
	Display Kit for SAV system with VFD		X
<b>Low Ambient Control</b>	Winter start kit <sup>4</sup>		X
	Motormaster® head pressure controller <sup>4</sup>		X
<b>Power Options</b>	Convenience outlet (powered)	X	
	Convenience outlet (un-powered): 15 amps factory-installed, 20 amp field-installed	X	X
	Non-fused disconnect <sup>5</sup>	X	
	Disconnect Switch Bracket (16 size only)		X
<b>Roof Curbs</b>	Roof curb 14-in. (356mm)		X
	Roof curb 24-in. (610mm)		X

NOTES:

- Novation® coated coils only available with E-coat.
- Included with economizer.
- Sensors used to optimize economizer performance.
- See application data for assistance.
- Available on units with MOCs of 80 amps or less.
- FDD (Fault Detection and Diagnostic) capability per California Title 24 120.2i, ASHRAE 90.1-2016 and IECC-2015 Fault Detection and Diagnostic (FDD) requirements.

- Models with RTU Open DDC controls comply with California Title 24 120.2i, ASHRAE 90.1-2016 and IECC-2015 Fault Detection and Diagnostic (FDD) requirements. PremierLink is non FDD.
- Not available on models with SAV. SAV is required on all U.S. installations.
- Required on all 48TC°D/E models to meet DOE-2018.
- Requires a field-supplied 24V transformer for each application. See price pages for details.

## Factory-installed options

### Economizer

Economizers save energy, money and improve comfort levels in the conditioned space. They bring in fresh, outside air for ventilation; and provide cool outside air to cool your building. This also is the preferred method of low ambient cooling. When integrated with CO<sub>2</sub> sensors, economizers can provide even more savings by coupling the ventilation air to only that amount required based on space occupancy.

Economizers are available, installed and tested by the factory, with either enthalpy or temperature dry-bulb inputs. There are also models for electromechanical, direct digital controllers and single speed fan or 2-speed indoor fan motors. Additional sensors are available as accessories to optimize the economizer.

Economizers include gravity controlled barometric relief that helps equalize building pressure and ambient air pressures. This can be a cost effective solution to prevent building pressurization. Economizers are available in ultra low leak and low leak versions.

### CO<sub>2</sub> sensor

Improves productivity and saves money by working with the economizer to intake only the correct amount of outside air for ventilation. As occupants fill your building, the CO<sub>2</sub> sensor detects their presence through increasing CO<sub>2</sub> levels, and opens the economizer appropriately.

When the occupants leave, the CO<sub>2</sub> levels decrease, and the sensor appropriately closes the economizer. This intelligent control of the ventilation air, called Demand Controlled Ventilation (DCV), reduces the overall load on the rooftop, saving money.

### Smoke detectors

Smoke detectors make your rooftop unit application safer and your job easier. Carrier smoke detectors immediately shut down the rooftop unit when smoke is detected. They are available, installed by the factory, for supply air, return air, or both.

### Louvered hail guards

Sleek, louvered panels protect the condenser coil from hail damage, foreign objects, and incidental contact.

### Convenience outlet (powered or un-powered)

Reduce service and/or installation costs by including a convenience outlet in your specification. Carrier will install this service feature at our factory. Provides a convenient, 15 amp, 115v GFCI receptacle with "Wet in Use" cover. The "powered" option allows the installer to power the outlet from the line side of the disconnect side as required by code. The "un-powered" option is to be powered from a separate (non-unit) 115/120v power source. The unpowered convenience outlet is available as a 15 amp factory-installed option or a 20 amp field-installed accessory.

The field installed 20 amp unpowered convenience outlet kit provides a flexible installation method which allows code compliance for height requirements of the GFCI outlet from the finished roof surface as well as the capability to relocate the outlet to a more convenient location, if necessary.

### Non-fused disconnect

This OSHA-compliant, factory-installed, safety switch allows a service technician to locally secure power to the rooftop.

### Power exhaust with barometric relief

Superior internal building pressure control. This field-installed accessory or factory-installed option may eliminate the need for costly, external pressure control fans.

### PremierLink™ DDC controller

This CCN controller regulates your rooftop's performance to tighter tolerances and expanded limits, as well as facilitates zoning systems and digital accessories. It also unites your Carrier HVAC equipment together on one, coherent CCN network. The PremierLink controller can be factory installed, or easily field installed. Not available with 2-speed Staged Air Volume (SAV™) system. SAV is required on all U.S. installed 48TC\*D/E models.

### RTU Open multi-protocol controller

Connect the rooftop to an existing Building Automation System (BAS) without needing complicated translators or adapter modules using the RTU Open controller. This new controller speaks the 4 most common building automation system languages (BACnet<sup>1</sup>, Modbus<sup>2</sup>, LonWorks<sup>3</sup>, and N2). Use this controller when you have an existing BAS.

### Motorized 2-position damper

The Carrier 2-position, motorized outdoor air damper admits up to 100% outside air. Using reliable, gear-driven technology, the 2-position damper opens to allow ventilation air and closes when the rooftop stops, stopping unwanted infiltration.

### Optional Humidi-MiZer® adaptive dehumidification system

Carrier's Humidi-MiZer® adaptive dehumidification system is an all-inclusive factory-installed option that can be ordered with any WeatherMaker® 48TC07-16 rooftop unit equipped with Round Tube-Plate Fin (RTPF) coils. Not available on single circuit, 2-stage cooling 48TC\*M models from 7.5 to 10 tons.

This system expands the envelope of operation of Carrier's WeatherMaker rooftop products to provide unprecedented flexibility to meet year round comfort conditions.

The Humidi-MiZer adaptive dehumidification system has a unique dual operational mode setting. The Humidi-MiZer system includes two new modes of operation.

The WeatherMaker 48TC rooftop coupled with the Humidi-MiZer system is capable of operating in normal design cooling mode, subcooling mode, and hot gas reheat mode. Normal design cooling mode is when the unit will operate under its normal sequence of operation by cycling compressors to maintain comfort conditions.

Subcooling mode will operate to satisfy part load type conditions when the space requires combined sensible and a

1. BACnet is a registered trademark of ASHRAE (American Society of Heating, Refrigerating and Air-Conditioning Engineers).
2. Modbus is a registered trademark of Schneider Electric.
3. LonWorks is a registered trademark of Echelon Corporation.

higher proportion of latent load control. Hot Gas Reheat mode will operate when outdoor temperatures diminish and the need for latent capacity is required for sole humidity control. Hot Gas Reheat mode will provide neutral air for maximum dehumidification operation.

## **Staged air volume (SAV™) 2-speed indoor fan system**

Carrier's Staged Air Volume (SAV) 2-speed indoor fan motor system saves energy and installation time by automatically adjust the indoor fan motor speed in sequence with the units cooling operation. Per ASHRAE 90.1-2016 and IECC-2015 standards, during the first stage of cooling operation the system will adjust the fan motor to provide 66% of the total cfm established for the unit. When a call for the second stage of cooling is required, the system will allow the total cfm for the unit established (100%). During the heating mode the fan speed will allow total design cfm (100%) operation and during the ventilation mode the fan speed will allow operation to 66% of total cfm.

Compared to single speed indoor fan motor systems, Carrier's SAV system can save substantial energy, 25%+ versus single speed indoor fan motor systems.

**IMPORTANT:** Data based on 0.10 (\$/kWh) in an office application utilizing Carrier's HAP 4.6 simulation software program.

Carrier's SAV system has soft start capabilities to slowly ramp up the fan speeds, thus eliminating any high inrush air volume during initial start-up. It also has internal over current protection for the fan motor and a field-installed display kit that allows adjustment and in depth diagnostics if required.

This SAV 2-speed indoor fan motor system will allow both space sensor and conventional thermostats controls to be used to provide accurate control in any application.

The SAV 2-speed indoor fan motor system is factory pre-programmed and tested and requires no field adjustment to set up. The unit fan performance static pressure and cfm can be easily adjusted using the traditional means of belt drive pulley adjustments.

## **Hinged access panels**

Allows access to unit's major components with specifically designed hinged access panels. Panels are: filter, control box, and fan motor.

## **Optional stainless steel heat exchanger**

The stainless steel heat exchanger option provides the tubular heat exchanger be made out of a minimum 20 gage type 409 stainless steel for applications where the mixed air to the heat exchanger is expected to drop below 45°F (7°C). Stainless steel may be specified on applications where the presence of airborne contaminants require its use (applications such as paper mills) or in area with very high outdoor humidity that may result in severe condensation in the heat exchanger during cooling operation.

## **Alternate motors and drives**

Some applications need larger horsepower motors, some need more airflow, and some need both. Regardless of the

case, your Carrier expert has a factory-installed combination to meet your application. A wide selection of motors and pulleys (drives) are available, factory-installed, to handle nearly any application.

## **Thru-the-base connections**

Thru-the-base connections, available as either an accessory or as a factory option, are necessary to ensure proper connection and seal when routing wire and piping through the rooftop's basepan and curb. These couplings eliminate roof penetration and should be considered for gas lines, main power lines, as well as control power.

## **Condensate Overflow Switch**

Includes electronic controller and sensor. Compressor(s) turn off if the drain trap becomes plugged but the indoor fan motor remains running.

## **Field-installed accessories**

### **Disconnect switch bracket**

Provides a pre-engineered and sized mounting bracket for applications requiring a unit mounted fused and non-fused disconnect of greater than 100 amps. Bracket assures that no damage will occur to coils when mounting with screws and other fasteners (16 size only).

### **Time guard II control circuit**

This accessory protects your compressor by preventing short-cycling in the event of some other failure, prevents the compressor from restarting for 30 seconds after stopping. Not required with PremierLink™ controller, RTU Open controller, or authorized commercial thermostats.

### **Manual OA damper**

Manual outdoor air dampers are an economical way to bring in ventilation air. The dampers are available in 25% and 50% versions.

### **Motormaster® head pressure controller**

The Motormaster motor controller is a low ambient, head pressure controller kit that is designed to maintain the unit's condenser head pressure during periods of low ambient cooling operation. This device should be used as an alternative to economizer free cooling when economizer usage is either not appropriate or desired. The Motormaster controller will either cycle the outdoor-fan motors or operate them at reduced speed to maintain the unit operation, depending on the model.

### **Winter start kit**

The winter start kit by Carrier extends the low ambient limit of your rooftop to 25°F (-4°C). The kit bypasses the low pressure switch, preventing nuisance tripping of the low pressure switch. Other low ambient precautions may still be prudent.

### **Propane heating**

Convert your gas heat rooftop from standard natural gas operation to propane using this field-installed kit.

### **High altitude heating**

High altitudes have less oxygen, which means heat exchangers need less fuel. The new gas orifices in this field-installed



kit make the necessary adjustment for high altitude applications. They restore the optimal fuel to air mixture and maintain healthy combustion at altitudes above 2000 ft (610 m). Kits may not be required in all areas.

### Flue discharge deflector

The flue discharge deflector is a useful accessory when flue gas recirculation is a concern. By venting the flue discharge upwards, the deflector minimizes the chance for a neighboring unit to intake the flue exhaust (07-14 sizes only).

### Flue discharge heat shield

The flue discharge heat shield keeps people from touching the rooftop unit's potentially hot flue discharge. This is especially useful for ground level applications, where more, untrained people could have access to the unit's exterior (07-14 sizes only).

### Supply duct cover

This supply duct cover is required when field converting the factory standard vertical duct supply to the horizontal duct supply configuration. One required per unit (16 size only).

## OPTIONS AND ACCESSORIES — WEIGHT ADDERS

BASE UNIT WITH OPTIONS AND ACCESSORIES (WEIGHT ADDERS)	MAX WEIGHT ADDER											
	48TC**07		48TC**08		48TC**09		48TC**12		48TC**14		48TC**16	
	lb	kg	lb	kg	lb	kg	lb	kg	lb	kg	lb	kg
Humidi-MiZer® System <sup>1, 2</sup>	55	25	80	36	80	36	80	36	80	36	90	41
Power Exhaust, Vertical	50	23	75	34	75	34	75	34	75	34	85	39
Power Exhaust, Horizontal	30	14	30	14	30	14	30	14	30	14	75	34
EconoMiSer® (IV, X, or 2)	50	23	74	34	74	34	74	34	74	34	103	47
Cu/Cu Condenser Coil <sup>3</sup>	28	13	28	13	30	14	34	15	34	15	34	15
Cu/Cu Condenser and Evaporator Coils <sup>3</sup>	53	24	58	26	64	29	64	29	64	29	64	29
Medium Gas Heat	9	4	15	7	15	7	18	8	18	8	28	13
High Gas Heat	17	8	29	13	29	13	35	16	35	16	50	23
Flue Discharge Deflector	7	3	7	3	7	3	7	3	7	3	7	3
Roof Curb 14-in. (356 mm)	115	52	143	65	143	65	143	65	143	65	180	82
Roof Curb 24-in. (610 mm)	197	90	245	111	245	111	245	111	245	111	255	116
Louvered Hail Guard	16	7	34	15	34	15	34	15	34	15	45	20
CO <sub>2</sub> sensor	5	2	5	2	5	2	5	2	5	2	5	2
Return Smoke Detector	5	2	5	2	5	2	5	2	5	2	5	2
Supply Smoke Detector	5	2	5	2	5	2	5	2	5	2	5	2
Fan/Filter Status Switch	2	1	2	1	2	1	2	1	2	1	2	1
Non-Fused Disconnect	15	7	15	7	15	7	15	7	15	7	15	7
Powered Convenience Outlet	35	16	35	16	35	16	35	16	35	16	35	16
Non-Powered Convenience Outlet	5	2	5	2	5	2	5	2	5	2	5	2
Enthalpy Sensor	2	1	2	1	2	1	2	1	2	1	2	1
Differential Enthalpy Sensor	3	1	3	1	3	1	3	1	3	1	3	1
Two Position Motorized Damper	39	18	58	26	58	26	58	26	58	26	65	29
Manual Outdoor Air Damper	12	2	18	8	18	8	18	8	18	8	25	11
Motormaster® Controller	35	16	35	16	35	16	35	16	40	18	40	18
Medium Static Motor/Drive	5	2	6	3	6	3	6	3	10	5	10	5
High Static Motor/Drive <sup>4</sup>	11	5	12	5	16	7	16	7	20	9	20	9
SAV™ 2-Speed Indoor Fan Motor System	20	9	20	9	20	9	20	9	20	9	20	9

<sup>1</sup> For Humidi-MiZer® System add Motormaster Controller.

<sup>2</sup> Humidi-MiZer system is not available for 48TC\*M08/09/12 units.

<sup>3</sup> Where available.

<sup>4</sup> High static motor/drive is not available for 48TC\*M08 units.



## 48TC\*07 UNITS BUILT ON OR AFTER 4/15/2019

DRAWING REPRESENTS PRODUCT BUILT ON AND AFTER 04/15/2019  
(STARTING WITH SERIAL NUMBER 1619... ) SEE DETAIL "E" SHT 5

**NOTES:**  
 1. DIMENSIONS ARE IN INCHES. DIMENSIONS IN [ ] ARE IN MILLIMETERS.  
 2. CENTER OF GRAVITY  
 3. DIRECTION OF AIR FLOW  
 4. ALL VIEW DRAWN USING 3RD ANGLE

UNIT	J	K
48TC*07	41-3/8 [1051]	14-7/8 [371]

**CONNECTION SIZES**

	A	B	C	D	E	F	G	
	1 3/8" [35]	DIA FIELD POWER SUPPLY KNOCKOUT	2" [50]	DIA POWER SUPPLY KNOCKOUT	1 3/4" [44]	DIA GAGE ACCESS PLUG	7/8" [22]	DIA FIELD CONTROL WIRING HOLE
	3/4" [19]	DIA CONDENSATE DRAIN	1 1/2" [38]	DIA GAS CONNECTION	1 1/2" [38]	DIA POWER SUPPLY KNOCK-OUT		

**TURN THE BASE CHART THESE HOLES REQUIRED FOR USE THESE HOLE SIZES (MAX.)**

TURRETED CONDUIT SIZE	WIRE SIZE (MAX.)	RECTO HOLE SIZE (MAX.)
1/2"	115V 7/8" [22.2]	7/8" [22.2]
3/4"	240 7/8" [22.2]	7/8" [22.2]
1"	POWER 1-1/8" [28.6]	1-1/8" [28.6]
1 1/2"	POWER 1-1/8" [28.6]	1-1/8" [28.6]
2"	POWER 1-1/8" [28.6]	1-1/8" [28.6]

\* (008A00) PROVIDES 3/4" FPT THRU CURB FLANGE & FITTING.

**TOP VIEW**

**FRONT VIEW**

**LEFT VIEW**

**BACK VIEW**

**RIGHT VIEW**

**REVISIONS**

REV	DATE	SUPERCEDES	DESCRIPTION
1	12/27/2018	08/24/16	48TC 07 SINGLE ZONE ELECTRICAL COOLING WITH GAS HEAT

TIC CLASSIFICATION: U.S. ECCN:NSR  
 SHEET: 1 OF 5  
 DATE: 12/27/2018  
 SUPERCEDES: 08/24/16  
 481M500993

### 48TC\*\*07 UNITS BUILT PRIOR TO 4/15/2019

**NOTES:**

1. DIMENSIONS ARE IN INCHES. DIMENSIONS IN [ ] ARE IN MILLIMETERS.
2. CENTER OF GRAVITY
3. DIRECTION OF AIR FLOW
4. ALL VIEW DRAWN USING 3RD ANGLE

UNIT	J	K
48TC**07	41-3/8 [1051]	14-7/8 [377]

THIS DOCUMENT IS THE PROPERTY OF UTC CLIMATE, CONTROLS & SECURITY, AND IS BELIEVED TO BE THE EXPRESS CONDITION OF THESE CONTRACTS OR DOCUMENTS. IT IS TO BE RETURNED TO THE SUPPLIER IMMEDIATELY UPON COMPLETION OF THE PROJECT AND NOT BE REPRODUCED OR COPIED WITHOUT WRITTEN CONSENT.

**Carrier**  
© Carrier Technologies

DRAWING REPRESENTS PRODUCT BUILT ON AND PRIOR TO 04/14/2019  
SEE DETAIL "B" SHT 5

**CONNECTION SIZES**

	CONNECTION SIZES
A	1 3/8" [35] DIA. FIELD POWER SUPPLY HOLE
B	2" [50] DIA. POWER SUPPLY KNOCKOUT
C	1 3/4" [44] DIA. GAGE ACCESS PLUG
D	7/8" [22] DIA. FIELD CONTROL WIRING HOLE
E	3/4" - 1/4 NPT CONDENSATE DRAIN
F	1/2" - 1/4 NPT GAS CONNECTION
G	2 1/2" [64] DIA. POWER SUPPLY KNOCK-OUT

**TURN THE BASE CHART THESE HOLES REQUIRED FOR USE (SEE IMPR001A01) - 003A01**

THICKENED CONDUIT SIZE	WIRE SIZE (MAX.)	REQ'D HOLE SIZE (MAX.)
W	1/2"	1 1/8" [28.6]
X	3/4"	2 1/8" [54.1]
Y	1 1/2"	4 1/8" [108.3]
Z**	003A01, 1/2" - FPT	1 1/8" [28.6]

FOR "THRU-THE-BASEPAN" FACTORY OPTION, FITTINGS FOR ONLY X, Y, & Z ARE PROVIDED. SELECT EITHER 3/4" OR 1/2". FOR POWER... DEPENDING ON WIRE SIZE. (001A01) PROVIDES 3/4" - FPT THRU CURB FLANGE & FITTING.

**TOP**

**BACK**

**LEFT**

**FRONT**

**RIGHT**

RETURN AIR HORIZONTAL

SUPPLY AIR HORIZONTAL

RETURN AIR VERTICAL

SUPPLY AIR VERTICAL

ITC CLASSIFICATION	SHEET	DATE	SUPERCEDES	REV
U.S. - ECCN-NSR	2 OF 5	12/27/18	08/24/16	I
48TC 07 SINGLE ZONE ELECTRICAL COOLING WITH GAS HEAT				481M500993

## 48TC\*\*07 CORNER WEIGHTS AND CLEARANCES

**Carrier**  
© Carrier Technologies

THIS DOCUMENT IS THE PROPERTY OF UTC CLIMATE CONTROLS. PERMISSION OF THESE DIMENSIONS OR DOCUMENTS IS SECURITY AND IS DELIVERED UPON THE EXPRESS CONDITION THAT THE USER WILL NOT REPRODUCE, COPIY, OR DISSEMINATE THIS DOCUMENT WITHOUT WRITTEN CONSENT.

THIS DOCUMENT IS THE PROPERTY OF UTC CLIMATE CONTROLS. PERMISSION OF THESE DIMENSIONS OR DOCUMENTS IS SECURITY AND IS DELIVERED UPON THE EXPRESS CONDITION THAT THE USER WILL NOT REPRODUCE, COPIY, OR DISSEMINATE THIS DOCUMENT WITHOUT WRITTEN CONSENT.

UNIT #	CORNER A		CORNER B		CORNER C		CORNER D		C.G.		HEIGHT						
	LBS.	KG.	LBS.	KG.	LBS.	KG.	LBS.	KG.	X	Y							
48TC0A07	652	296	150	68	169	76	116	80	157	71	39	190	23	584	20	1/8	1511

\* STANDARD UNIT WEIGHT IS WITH LOW GAS HEAT AND WITHOUT PACKAGING. FOR OTHER OPTIONS AND ACCESSORIES, REFER TO THE PRODUCT DATA CATALOG.

NOTES:

- FOR ALL MINIMUM CLEARANCES LOCAL CODES OR JURISDICTIONS MAY PREVAIL.

CLEARANCE		OPERATING	
SURFACE	SERVICE WITH CONDUCTIVE BARRIER	SERVICE WITH NONCONDUCTIVE BARRIER	CLEARANCE
FRONT	48 [1219mm]	36 [914mm]	18 [457mm]
LEFT	48 [1219mm]	42 [1067mm]	18 [457mm]
BACK	48 [1219mm]	42 [1067mm]	18 [457mm]
BACK W/HOOD	36 [914mm]	36 [914mm]	18 [457mm]
RIGHT	36 [914mm]	36 [914mm]	18 [457mm]
TOP	72 [1829mm]	72 [1829mm]	72 [1829mm]

ITC CLASSIFICATION  
U.S. - ECCN: NSR

SHEET  
3 OF 5

DATE  
12/27/18

SUPERCEDES  
08/24/16

  

48TC 07 SINGLE ZONE ELECTRICAL COOLING WITH GAS HEAT

481M500993

REV  
I

### 48TC\*\*07 BASE RAIL DETAILS

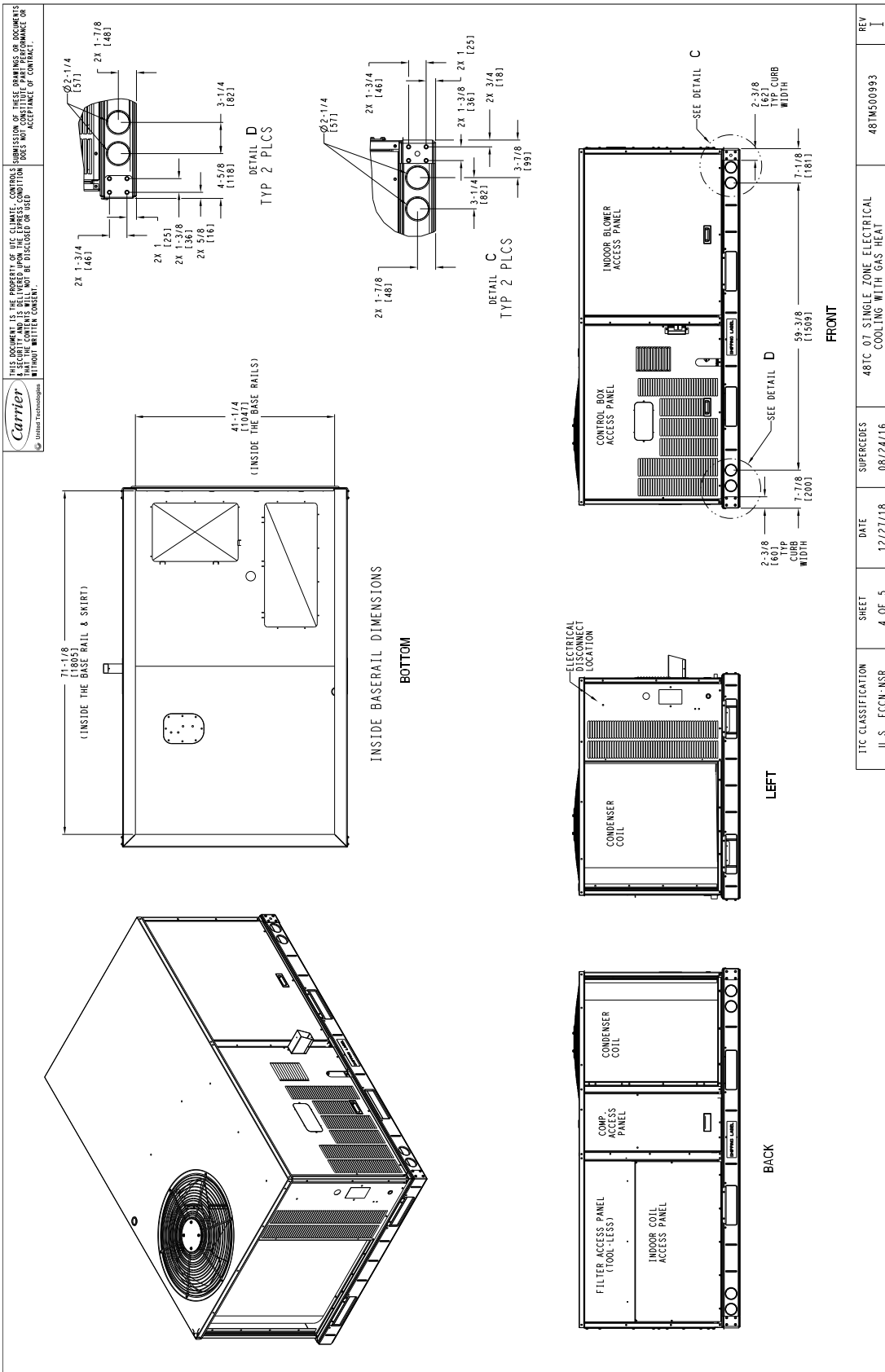

ITC CLASSIFICATION U.S. - ECCN: NSR	SHEET 4 OF 5	DATE 12/27/18	SUPERCEDES 08/24/16	48TC 07 SINGLE ZONE ELECTRICAL COOLING WITH GAS HEAT	REV I
--	-----------------	------------------	------------------------	---	----------

## 48TC\*\*07 THRU-THE-BASE CHARTS

THRU-THE-BASE CHART THESE HOLES REQUIRED FOR USE CGRTHR001A01, 003A01			
THREADED CONDUIT SIZE	WIRE USE	REQ'D HOLE SIZES (MAX.)	
W	1/2"	115V 7/8" [22.2]	
X	1/2"	24V 7/8" [22.2]	
Y	3/4"	POWER 1 1/8" [28.6]	
Z**	(003A01) 1/2" FPT	GAS 1 1/8" [28.6]	

FOR "THRU-THE-BASEPAN" FACTORY OPTION,  
FITTINGS FOR ONLY X, Y, & Z ARE PROVIDED  
FOR POWER, DEPENDING ON WIRE SIZE  
SELECT EITHER 3/4" OR 1/2".  
(001A01) PROVIDES 3/4" FPT THRU CURB  
FLANGE & FITTING.

THRU-THE-BASE CHART THESE HOLES REQUIRED FOR USE CGRTHR008A01, 109A01			
THREADED CONDUIT SIZE	WIRE USE	REQ'D HOLE SIZES (MAX.)	
W	1/2"	115V 7/8" [22.2]	
X	1/2"	24V 7/8" [22.2]	
Y	3/4"	POWER 1 1/8" [28.6]	
Z*	(008A01) 1/2" FPT	GAS 1 1/8" [28.6]	

FOR "THRU-THE-BASEPAN" FACTORY OPTION,  
FITTINGS FOR ONLY X, Y, & Z ARE PROVIDED  
FOR POWER, DEPENDING ON WIRE SIZE  
SELECT EITHER 3/4" OR 1/2".  
(008A01) PROVIDES 1/2" FPT THRU CURB  
FLANGE & FITTING.

DETAIL B  
FROM SHEET 2

DETAIL E  
FROM SHEET 1

THIS VIEW REPRESENTS PRODUCT BUILT ON AND PRIOR TO 04/14/2019

THIS VIEW REPRESENTS PRODUCT BUILT ON AND AFTER 04/15/2019

TIC CLASSIFICATION	SHEET	DATE	SUPERCEDES
U.S. ECCN: NSR	5 OF 5	12/27/18	08/24/16

REV	REV
I	I

## UNIT DIMENSIONAL DRAWING - UNIT SIZE 48TC 07 — ROOF CURB DETAILS

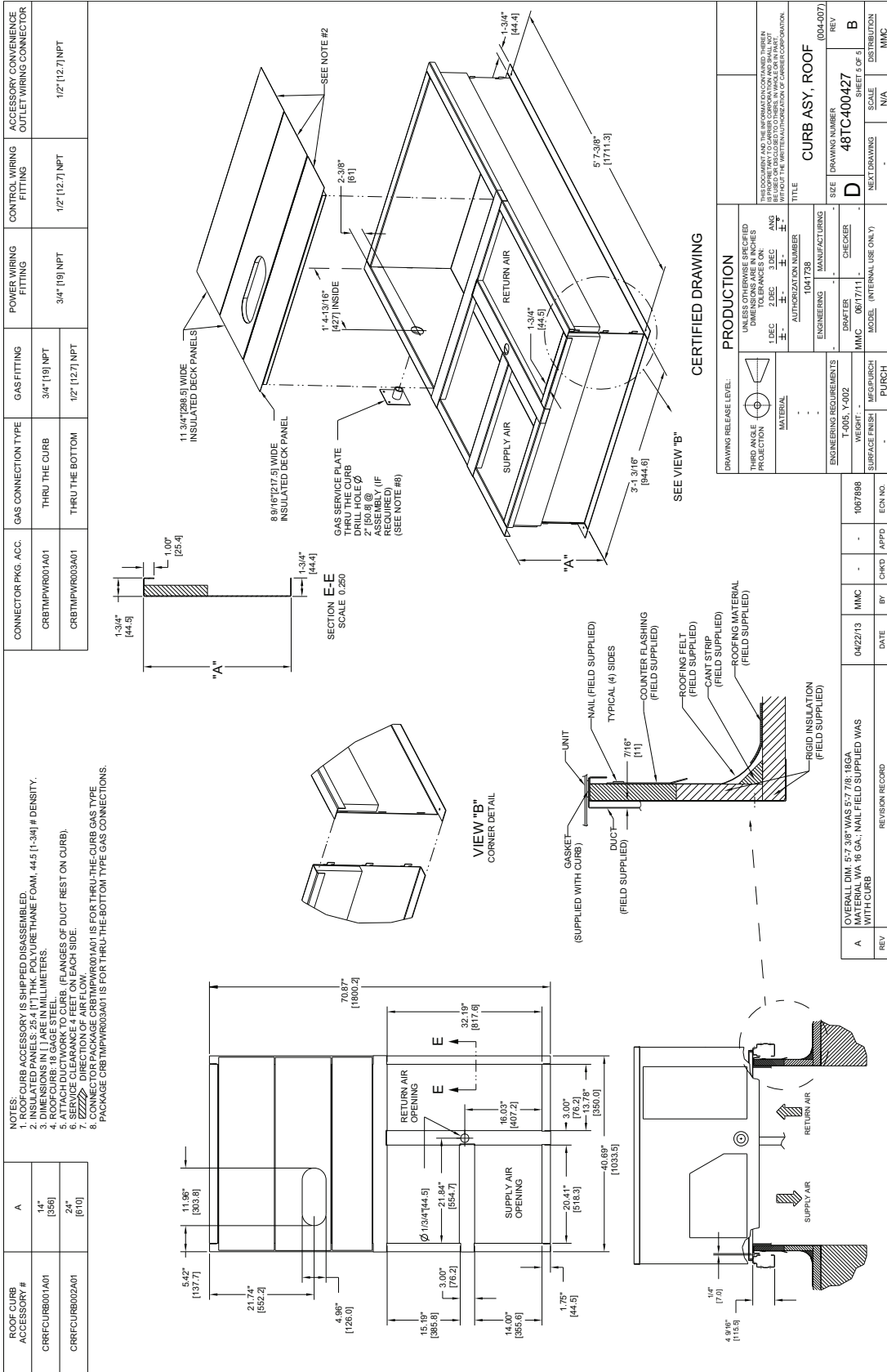

<b>CERTIFIED DRAWING</b>	
DRAWING RELEASE LEVEL: THIRD ANGLE PROJECTION UNLESS OTHERWISE SPECIFIED DIMENSIONS ARE IN INCHES 1 DEC 2 DEC 3 DEC ANG ± ± ± ± ±	AUTHORIZATION NUMBER 1041738 ENGINEERING MANUFACTURING DRAFTER CHECKER MODEL SURFACE FINISH PURCH
<b>TITLE</b> <b>CURB ASY, ROOF</b> SIZE <b>48TC400427</b> DRAWING NUMBER SHEET 5 OF 5 DISTRIBUTION SCALE N/A NEXT DRAWING N/A	
PRODUCTION T-005, Y-002 WEIGHT: - MFC/PURCH PURCH	
ENGINEERING REQUIREMENTS T-005, Y-002 SURFACE FINISH MFC/PURCH PURCH	
REVISION RECORD DATE BY CHKD APPD ECN NO.	
OVERALL DIM: 57.38" WAS 57.778; 18GA MATERIAL WA 16 GA; NAIL FIELD SUPPLIED WAS WITH CURB REVISION RECORD DATE BY CHKD APPD ECN NO.	

## 48TC\*\*08-12 UNIT DIMENSIONAL DRAWING

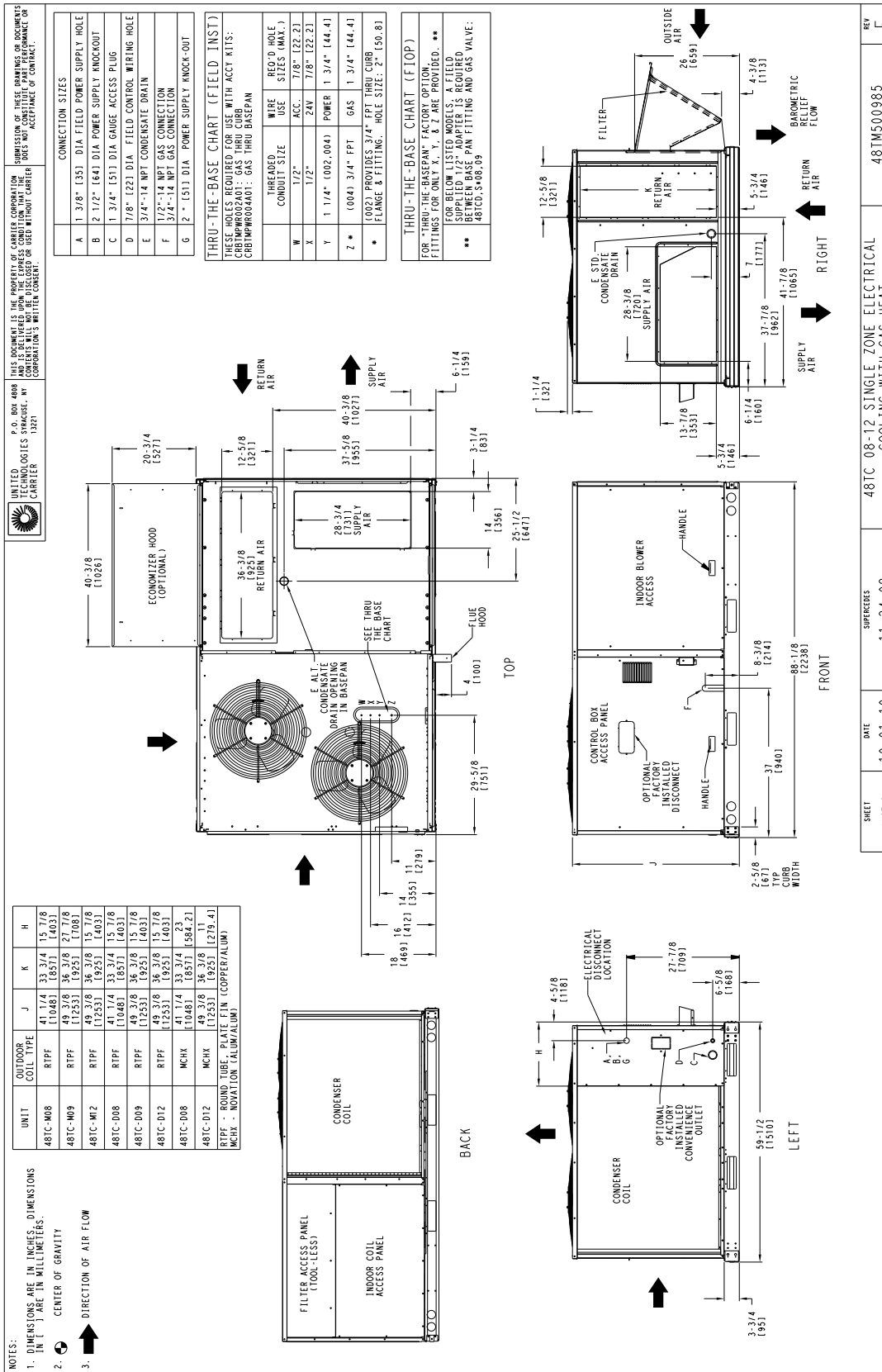

SHEET	DATE	SUPERSEDES	REV
1 OF 2	10-01-10	48TC 08-12 SINGLE ZONE ELECTRICAL COOLING WITH GAS HEAT	F



### 48TC\*\*08-12 UNIT DIMENSIONAL DRAWING (cont)

**UNITED TECHNOLOGIES STRATEGIC**  
**CARRIER**  
 P. O. BOX 4809  
 THIS DOCUMENT IS THE PROPERTY OF CARRIER CORPORATION  
 AND IS TO BE KEPT IN CONFIDENCE AND NOT TO BE REPRODUCED OR  
 TRANSMITTED IN ANY FORM OR BY ANY MEANS, ELECTRONIC OR  
 MECHANICAL, INCLUDING PHOTOCOPYING, RECORDING, OR BY  
 INFORMATION STORAGE AND RETRIEVAL SYSTEMS, WITHOUT CARRIER  
 CORPORATION'S WRITTEN CONSENT.  
 COMMISSION OF THESE DRAWINGS OR DOCUMENTS  
 DOES NOT CONSTITUTE AN ACCEPTANCE OF CONTRACT.

\*\*\* STANDARD UNIT WEIGHT IS WITH LOW GAS HEAT AND WITHOUT PACKAGING.  
 FOR OTHER OPTIONS AND ACCESSORIES, REFER TO THE PRODUCT DATA CATALOG.

UNIT	OUTDOOR COIL TYPE	STD. UNIT WEIGHT		CORNER WEIGHT (A)		CORNER WEIGHT (B)		CORNER WEIGHT (C)		CORNER WEIGHT (D)		C.G.								
		LESS T. KG.	LESS T. LBS.	KG.	LBS.	KG.	LBS.	KG.	LBS.	KG.	LBS.	X	Y	Z						
48TC-M08	R1PF	780	354	178	83	158	72	209	95	236	107	41	172	11054	33	7/8	1860	20	1/2	1521
48TC-M09	R1PF	920	418	212	96	183	83	243	110	282	128	40	178	11038	34	1/8	1884	23	1/8	1587
48TC-M12	R1PF	930	422	216	98	186	89	247	112	272	123	42	178	11061	33	1/8	1841	24	1/4	1616
48TC-D08	R1PF	835	379	164	74.5	170	77.2	255	115.8	246	111.1	44	178	11140	35	5/8	1905	19	3/8	1492
48TC-D09	R1PF	930	422	228	103.5	187	85	232	105.3	283	128.5	39	174	11010	32	7/8	1835	18	5/8	1473
48TC-D12	R1PF	940	427	231	104.9	189	85.8	234	106.2	286	129.8	39	174	11010	33	1/8	1838	18	1/2	1470
48TC-D12	MCIX	805	365.5	160	72.6	153	69.5	240	109	260	118	43	178	11092	36	3/8	1924	20	3/8	1517
48TC-D12	MCIX	895	406.5	182	84	176	79.9	260	118	274	124.4	42	178	11089	35	1/2	1902	22	7/8	1581

CORNER A

CORNER B

CORNER D

CORNER C

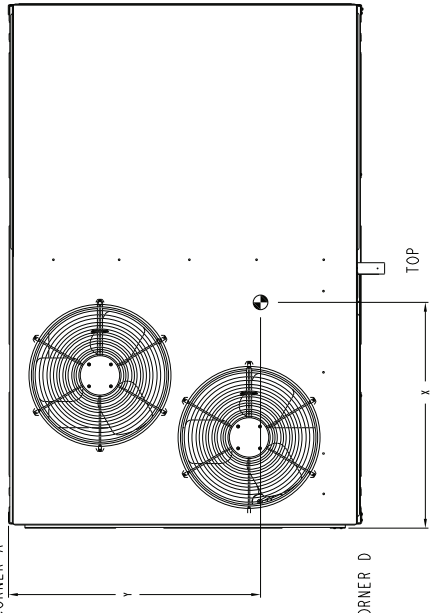

TOP

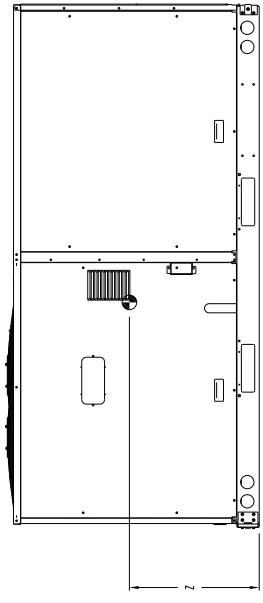

FRONT

SHEET 2 of 2	DATE 10-01-10	SUPERSEDES 11-24-08	48TC 08-12 SINGLE ZONE ELECTRICAL COOLING WITH GAS HEAT	48TM500985	REV F
-----------------	------------------	------------------------	--	------------	----------

## 48TC\*\*08-12 UNIT DIMENSIONAL DRAWING - SERVICE CLEARANCE

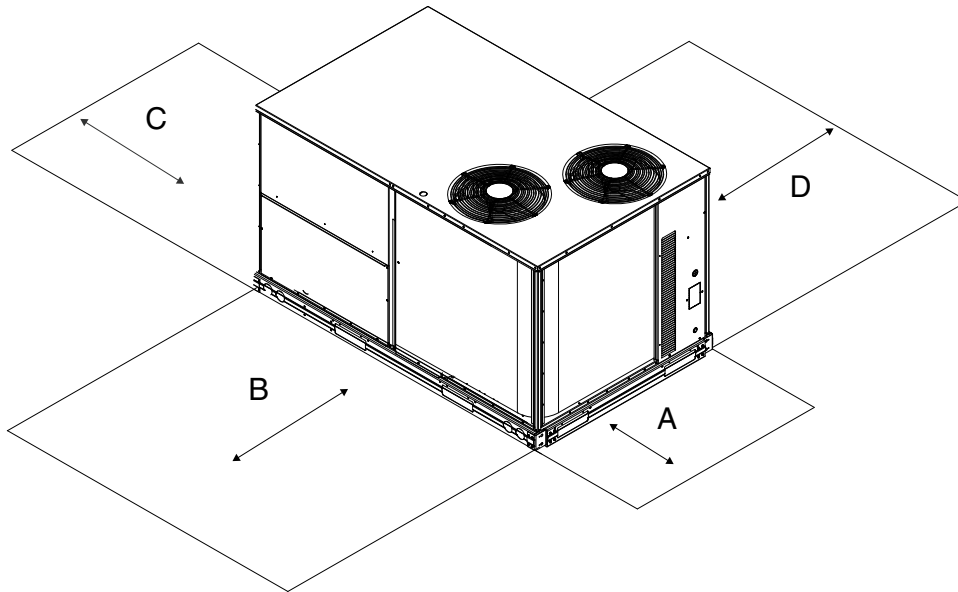

LOC	DIMENSION	CONDITION
A	48-in. (1219 mm) 36-in. (914 mm) 18-in. (457 mm) 18-in. (457 mm) 12-in. (305 mm)	<ul style="list-style-type: none"> <li>• Unit disconnect is mounted on panel</li> <li>• If dimension B is 12-in. (305 mm)</li> <li>• No disconnect, convenience outlet option</li> <li>• Recommended service clearance (electric screwdriver)</li> <li>• Minimum clearance (use manual ratchet screwdriver)</li> </ul>
B	36-in. (914 mm) 12-in. (305 mm) Special	<ul style="list-style-type: none"> <li>• Unit has economizer</li> <li>• If dimension A is 36-in. (914 mm)</li> <li>• Check for sources of flue products within 10 ft (3 m) of unit fresh air intake hood</li> </ul>
C	36-in. (914 mm) 18-in. (457 mm)	<ul style="list-style-type: none"> <li>• Side condensate drain is used</li> <li>• Minimum clearance</li> </ul>
D	48-in. (1219 mm) 42-in. (1067 mm) 36-in. (914 mm) Special	<ul style="list-style-type: none"> <li>• No flue discharge accessory installed, surface is combustible material</li> <li>• Surface behind servicer is grounded (e.g., metal, masonry wall, another unit)</li> <li>• Surface behind servicer is electrically non-conductive (e.g., wood, fiberglass)</li> <li>• Check for adjacent units or building fresh air intakes within 10 ft (3 m) of this unit's flue outlet</li> </ul>

NOTE: Unit not designed to have overhead obstruction.  
Contact Application Engineering for guidance on any application planning overhead obstruction or vertical clearances.

# 48TC\*\*08-14 UNIT DIMENSIONAL DRAWING — ROOF CURB DETAILS

ROOF CURB ACCESSORY #	A
CRFBURB003A01	14" [356]
CRFBURB004A01	24" [610]

- NOTES:  
 1. ROOFCURB ACCESSORY IS SHIPPED DISASSEMBLED.  
 2. INSULATED PANELS: 25.4 [1"] THK POLYURETHANE FOAM, 44.5 [1.34] # DENSITY.  
 3. DIMENSIONS IN ( ) ARE IN MILLIMETERS.  
 4. DIMENSIONS IN [ ] ARE IN INCHES.  
 5. ATTACH DUCTWORK TO CURB, (FLANGES OF DUCT REST ON CURB).  
 6. SERVICE CLEARANCE 4 FEET ON EACH SIDE.  
 7. DIRECTION OF AIR FLOW.  
 8. CONNECTOR PACKAGE CRBTMPWR002A01 IS FOR THRU-THE-CURB GAS TYPE PACKAGE CRBTMPWR004A01 IS FOR THRU-THE-BOTTOM TYPE GAS CONNECTIONS.

CONNECTOR PKG. ACC.	GAS CONNECTION TYPE	GAS FITTING	POWER WIRING FITTING	CONTROL WIRING FITTING	ACCESSORY CONVENIENCE OUTLET WIRING CONNECTOR
CRBTMPWR002A01	THRU THE CURB	3/4" [19] NPT	1 1/4" [31.7] NPT	1/2" [12.7] NPT	1/2" [12.7] NPT
CRBTMPWR004A01	THRU THE BOTTOM				

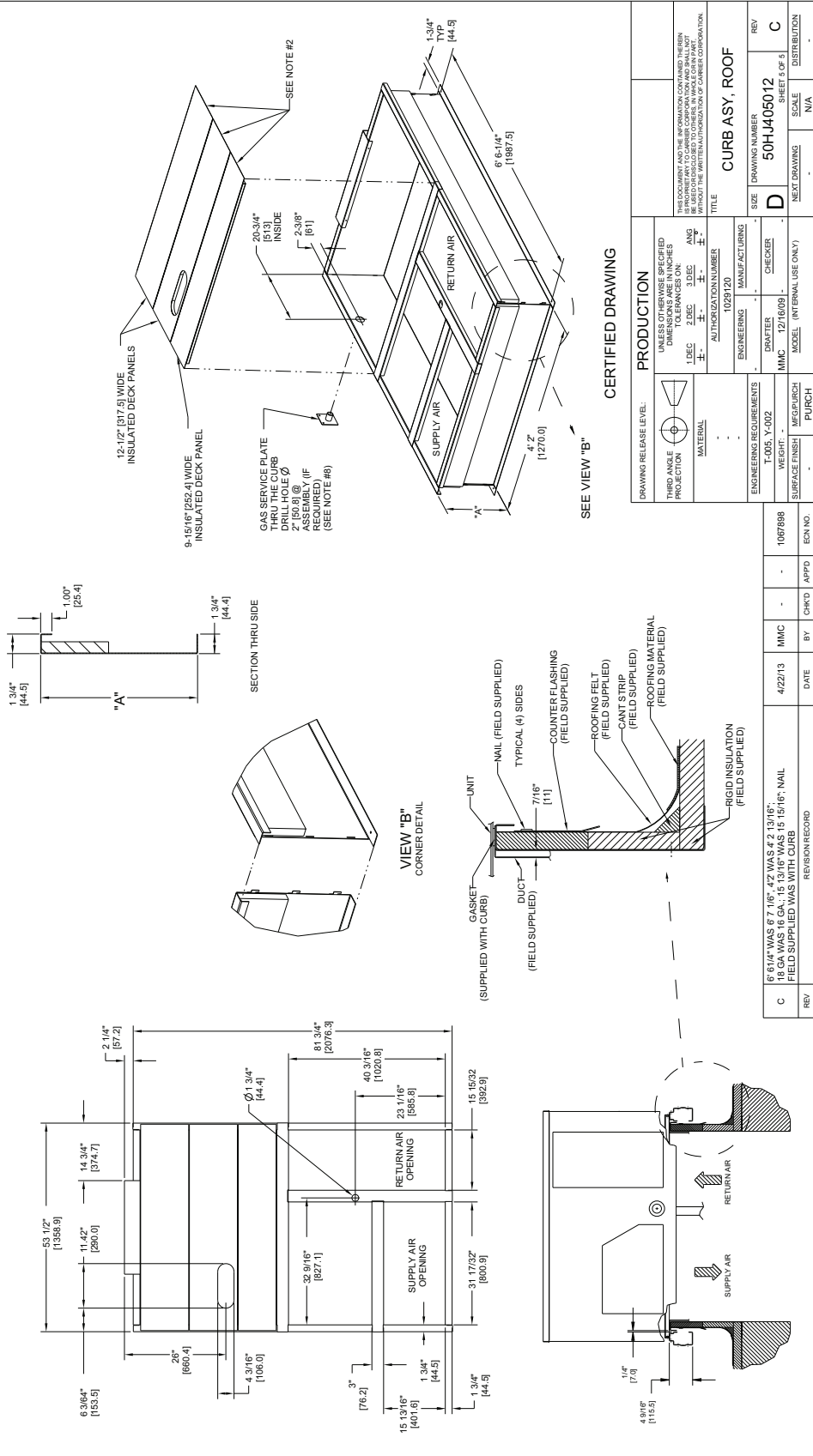

DRAWING RELEASE LEVEL: PRODUCTION UNLESS OTHERWISE SPECIFIED DIMENSIONS ARE IN INCHES 1 DEC 1.000 2 DEC 2.000 3 DEC 3.000 ANG 1/16" ± 1/32" ± 1/64" AUTHORIZATION NUMBER 1028120		ENGINEERING REQUIREMENTS T-005, V-002 WEIGHT: SURFACE FINISH PURCH		ENGINEERING 1028120		MANUFACTURING	
THIRD ANGLE PROJECTION		MATERIAL		DRAWN BY 12716009		CHECKED BY 12716009	
THIS DOCUMENT AND THE INFORMATION CONTAINED HEREIN IS PROPRIETARY TO CARRIER CORPORATION AND SHALL NOT BE REPRODUCED OR TRANSMITTED IN ANY FORM OR BY ANY MEANS, WITHOUT THE WRITTEN AUTHORIZATION OF CARRIER CORPORATION.		TITLE CURB ASY., ROOF		DRAWING NUMBER 50H-J405012		REV C	
NEXT DRAWING		SCALE		DISTRIBUTION			

REV	DATE	BY	CHKD	APPD	EN. NO.
C	4/22/13	MMC			1067898

6" 61/4" WAS 6" 7 1/8" 4Z WAS 4" 2 13/16"	18 GA WAS 16 GA. 15 13/16" WAS 15 15/16" NAIL	FIELD SUPPLIED WAS WITH CURB	REVISION/RECORD
---	---	------------------------------	-----------------

## 48TC\*\*14 UNIT DIMENSIONAL DRAWING

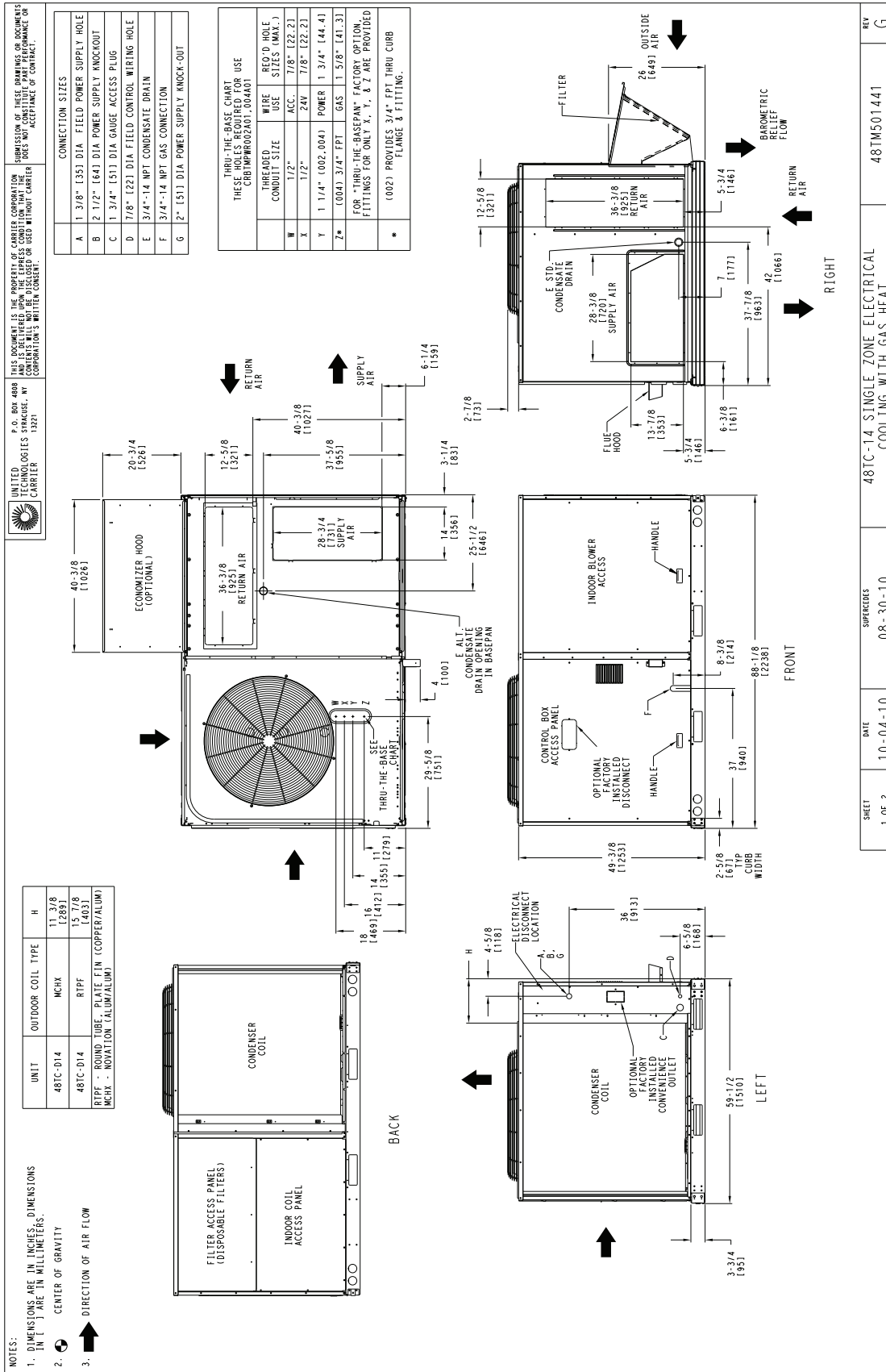

### 48TC\*\*14 UNIT DIMENSIONAL DRAWING (cont)

UNITED TECHNOLOGIES STRASSBURG, NY 13221  
P.O. BOX 4848  
THIS DOCUMENT IS THE PROPERTY OF CARRIER CORPORATION AND IS DELIVERED UPON THE EXPRESS CONDITION THAT THE RECIPIENT SHALL NOT REPRODUCE OR TRANSMIT IN ANY MANNER WITHOUT CARRIER'S WRITTEN CONSENT.

REVISIONS OF THESE DRAWINGS OR DOCUMENTS SHALL BE INDICATED BY A REVISION SYMBOL AND SHALL BE SUBJECT TO THE ACCEPTANCE OF CONTRACT.

\*\*\* STANDARD UNIT WEIGHT IS WITH LOW GAS HEAT AND WITHOUT PACKAGING. FOR OTHER OPTIONS AND ACCESSORIES, REFER TO THE PRODUCT DATA CATALOG.

UNIT	OUTDOOR COIL TYPE	STD. WEIGHT	CORNER WEIGHT***		CORNER WEIGHT (A)		CORNER WEIGHT (B)		CORNER WEIGHT (C)		CORNER WEIGHT (D)		C.G.							
			LBS.	KG.	LBS.	KG.	LBS.	KG.	LBS.	KG.	LBS.	KG.	X	Y	Z					
48TC-D14	MCHX	1116	506	297	135	157	71	229	104	434	197	29	17/2	1749	34	174	1870	20	1/4	15141
48TC-D14	RTPF	1167	530	349	159	167	76	211	96	440	200	31	3/8	1797	34	374	1883	21	7/8	1556

RTPF - ROUND TUBE - PLATE FIN (COPPER/ALUM)  
MCHX - MICROCHANNEL (ALUM/ALUM)

SHEET	DATE	SUPERSEDES	REV
2 OF 2	10-04-10	08-30-10	G

48TC-14 SINGLE ZONE ELECTRICAL COOLING WITH GAS HEAT  
48TM501441

## 48TC\*\*14 UNIT DIMENSIONAL DRAWING — SERVICE CLEARANCE

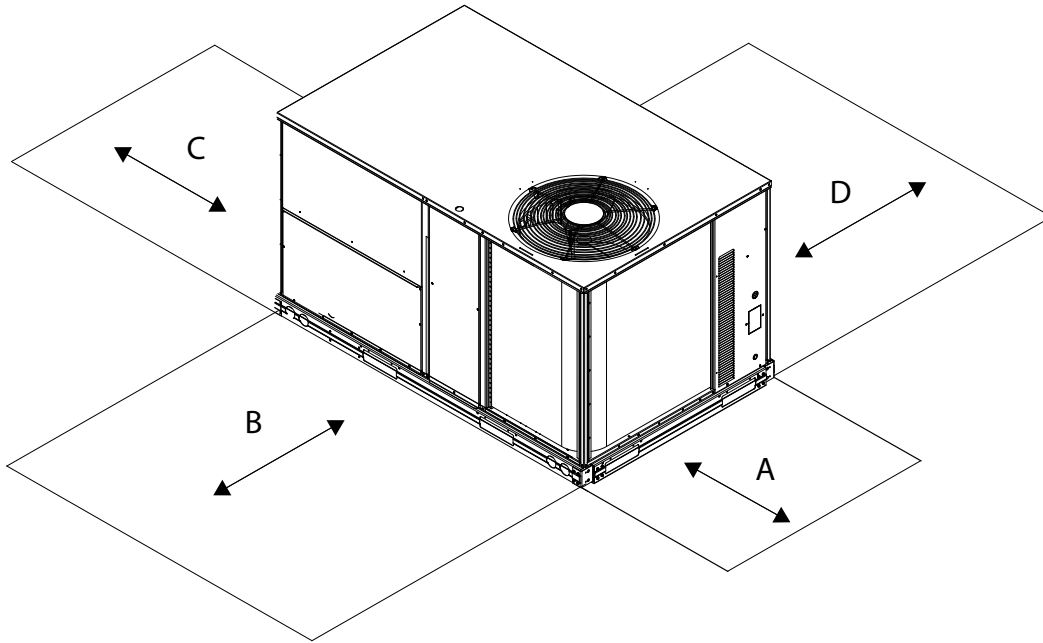

LOC	DIMENSION	CONDITION
A	48-in. (1219 mm) 18-in. (457 mm) 18-in. (457 mm) 12-in. (305 mm)	<ul style="list-style-type: none"> <li>• Unit disconnect is mounted on panel</li> <li>• No disconnect, convenience outlet option</li> <li>• Recommended service clearance</li> <li>• Minimum clearance</li> </ul>
B	42-in. (1067 mm) 36-in. (914 mm) Special	<ul style="list-style-type: none"> <li>• Surface behind servicer is grounded (e.g., metal, masonry wall)</li> <li>• Surface behind servicer is electrically non-conductive (e.g., wood, fiberglass)</li> <li>• Check for sources of flue products within 10 ft (3 m) of unit fresh air intake hood</li> </ul>
C	36-in. (914 mm) 18-in. (457 mm)	<ul style="list-style-type: none"> <li>• Side condensate drain is used</li> <li>• Minimum clearance</li> </ul>
D	48-in. (1219 mm) 42-in. (1067 mm) 36-in. (914 mm) Special	<ul style="list-style-type: none"> <li>• No flue discharge accessory installed, surface is combustible material</li> <li>• Surface behind servicer is grounded (e.g., metal, masonry wall, another unit)</li> <li>• Surface behind servicer is electrically non-conductive (e.g., wood, fiberglass)</li> <li>• Check for adjacent units or building fresh air intakes within 10 ft (3 m) of this unit's flue outlet</li> </ul>

NOTE: Unit not designed to have overhead obstruction.  
Contact Application Engineering for guidance on any application planning overhead obstruction or vertical clearances.

### 48TC\*\*16 UNIT DIMENSIONAL DRAWING

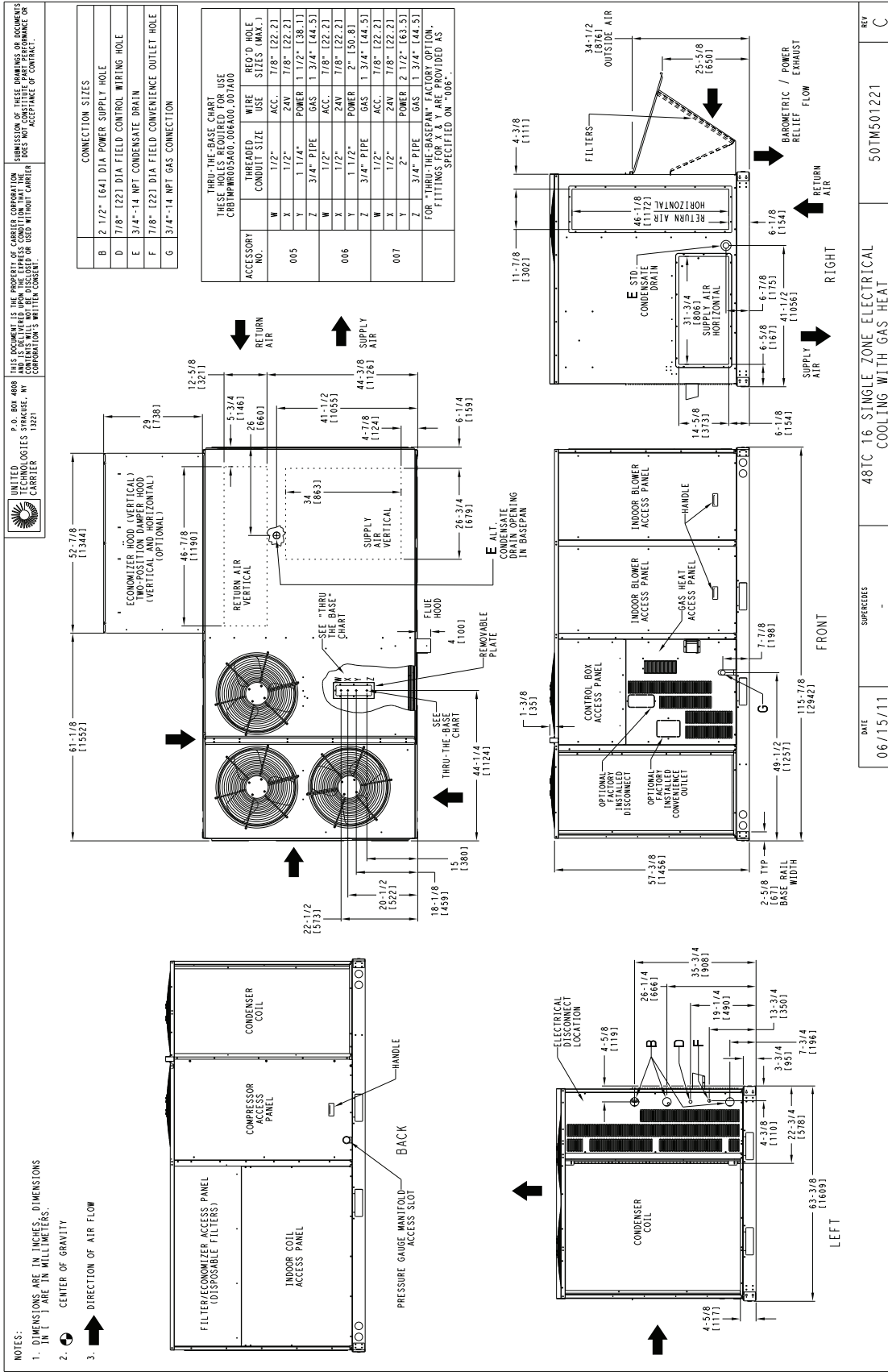

UNITED LOGISTICS SYSTEMS, NY  
CARRIER

P.O. BOX 4088  
UNITED LOGISTICS SYSTEMS, NY  
CARRIER

THIS DOCUMENT IS THE PROPERTY OF CARRIER CORPORATION. CONTENTS WILL NOT BE DISCLOSED OR USED WITHOUT CARRIER CORPORATION'S WRITTEN CONSENT.

REVISIONS OF THESE DRAWINGS OR DOCUMENTS WILL NOT BE DISCLOSED OR USED WITHOUT CARRIER CORPORATION'S ACCEPTANCE OF CONTRACT.

DATE: 06/15/11

SUPERSEDES: -

48TC 16 SINGLE ZONE ELECTRICAL COOLING WITH GAS HEAT

REV: 50TMS01221

C



## 48TC\*\*16 UNIT DIMENSIONAL DRAWING (cont)

UNITED STATES OF AMERICA  
P.O. BOX 4000  
MADISON, NJ 07042  
CARRIER

THIS DOCUMENT IS THE PROPERTY OF CARRIER CORPORATION. NO PARTS OF THIS DOCUMENT ARE TO BE REPRODUCED OR USED WITHOUT CARRIER CORPORATION'S WRITTEN CONSENT.

THIS DOCUMENT IS THE PROPERTY OF CARRIER CORPORATION. NO PARTS OF THIS DOCUMENT ARE TO BE REPRODUCED OR USED WITHOUT CARRIER CORPORATION'S WRITTEN CONSENT.

REVISIONS

REV	DESCRIPTION
C	

CORNER B

CORNER C

CORNER A

TOP

FRONT

48TC 16 SINGLE ZONE ELECTRICAL COOLING WITH GAS HEAT

DATE: 06/15/11

SUPERCEDES: -

50TM501221

UNIT	CORNER A		CORNER B		CORNER C		CORNER D		C.G.									
	WEIGHT (LBS.)	WEIGHT (KG.)	WEIGHT (LBS.)	WEIGHT (KG.)	WEIGHT (LBS.)	WEIGHT (KG.)	WEIGHT (LBS.)	WEIGHT (KG.)	X	Z								
48TC 16	1380	627	295	134	276	126	342	156	421	191	64	174	11630	35	1890	21	1/8	15371

STANDARD UNIT WEIGHT IS WITH LOW HEAT & WITHOUT PACKAGING. FOR OPTIONS & ACCESSORIES, REFER TO THE PRODUCT DATA CATALOG.

### 48TC\*\*16 UNIT DIMENSIONAL DRAWING — SERVICE CLEARANCE

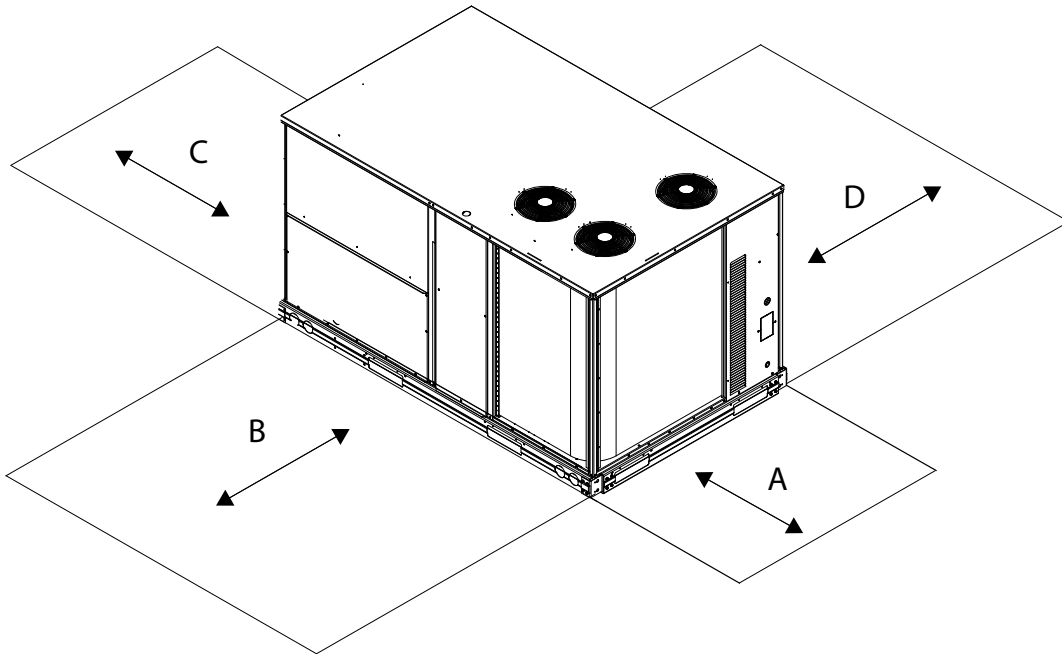

LOC	DIMENSION	CONDITION
A	48-in. (1219 mm) 18-in. (457 mm) 18-in. (457 mm) 12-in. (305 mm)	<ul style="list-style-type: none"> <li>• Unit disconnect is mounted on panel</li> <li>• No disconnect, convenience outlet option</li> <li>• Recommended service clearance</li> <li>• Minimum clearance</li> </ul>
B	42-in. (1067 mm) 36-in. (914 mm) Special	<ul style="list-style-type: none"> <li>• Surface behind servicer is grounded (e.g., metal, masonry wall)</li> <li>• Surface behind servicer is electrically non-conductive (e.g., wood, fiberglass)</li> <li>• Check for sources of flue products within 10 ft (3 m) of unit fresh air intake hood</li> </ul>
C	36-in. (914 mm) 18-in. (457 mm)	<ul style="list-style-type: none"> <li>• Side condensate drain is used</li> <li>• Minimum clearance</li> </ul>
D	48-in. (1219 mm) 42-in. (1067 mm) 36-in. (914 mm) Special	<ul style="list-style-type: none"> <li>• No flue discharge accessory installed, surface is combustibile material</li> <li>• Surface behind servicer is grounded (e.g., metal, masonry wall, another unit)</li> <li>• Surface behind servicer is electrically non-conductive (e.g., wood, fiberglass)</li> <li>• Check for adjacent units or building fresh air intakes within 10 ft (3 m) of this unit's flue outlet</li> </ul>

**NOTE:** Unit not designed to have overhead obstruction.  
Contact Application Engineering for guidance on any application planning overhead obstruction or vertical clearances.

## 48TC\*\*16 UNIT DIMENSIONAL DRAWING — ROOF CURB DETAILS

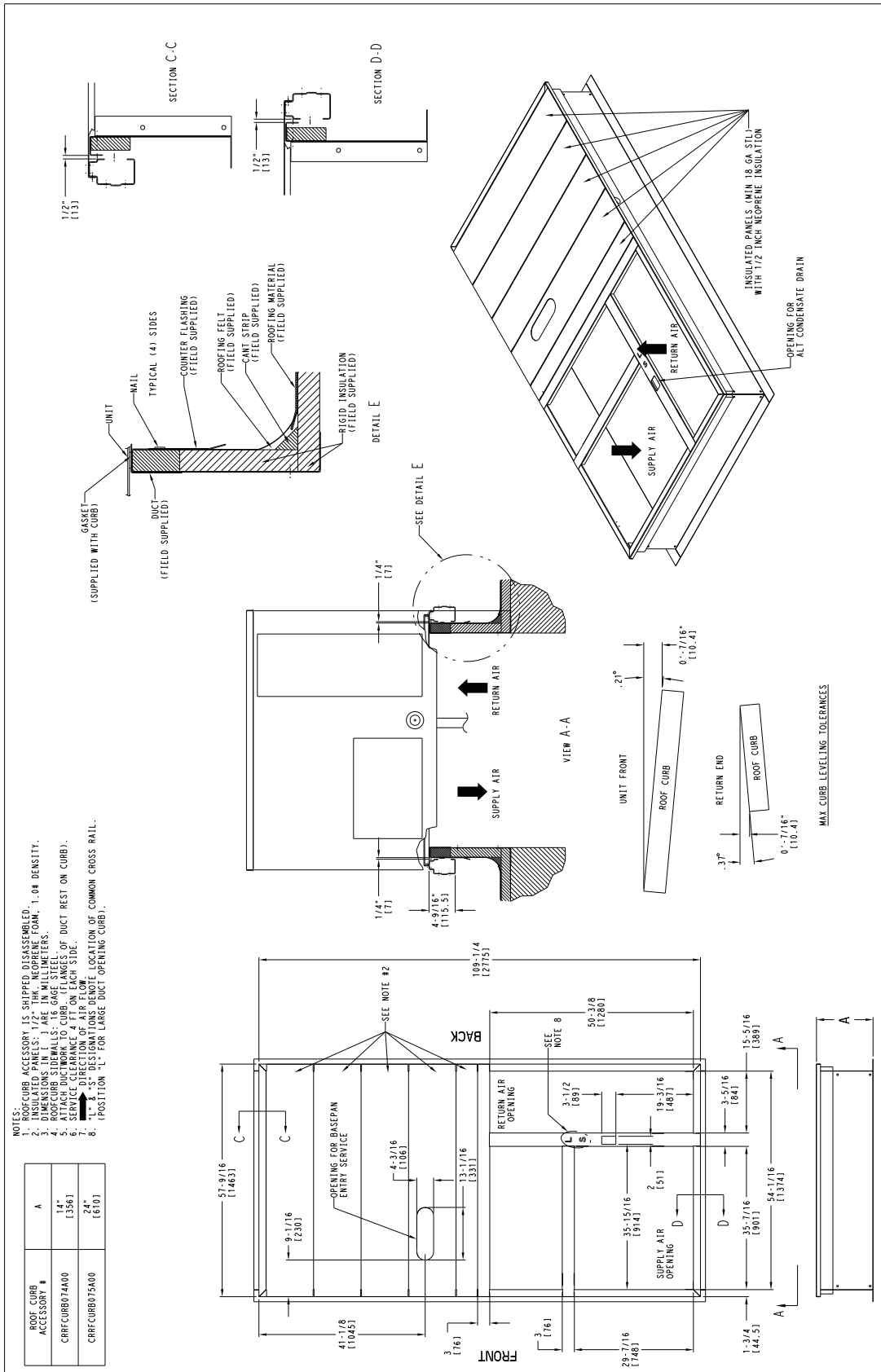

## COOLING CAPACITIES — 1-CIRCUIT/1-STAGE COOLING, 6 TONS

48TC-A07 (RTPF)			AMBIENT TEMPERATURE (F)													
			85			95			105			115				
			EAT (db)			EAT (db)			EAT (db)			EAT (db)				
			75	80	85	75	80	85	75	80	85	75	80	85		
1800 Cfm	EAT (wb)	58	TC	64.9	64.9	73.3	62.1	62.1	70.0	58.9	58.9	66.4	55.6	55.6	62.7	
			SHC	56.6	64.9	73.3	54.1	62.1	70.0	51.4	58.9	66.4	48.5	55.6	62.7	
		62	TC	68.7	68.7	70.3	64.9	64.9	68.5	60.8	60.8	66.4	56.4	56.4	64.0	
			SHC	51.7	61.0	70.3	49.9	59.2	68.5	47.9	57.2	66.4	45.7	54.9	64.0	
		67	TC	75.6	75.6	75.6	71.7	71.7	71.7	67.4	67.4	67.4	62.5	62.5	62.5	
			SHC	42.8	52.2	61.5	41.2	50.5	59.8	39.3	48.6	58.0	37.2	46.5	55.8	
	72	TC	82.6	82.6	82.6	78.5	78.5	78.5	73.7	73.7	73.7	67.8	67.8	67.8		
		SHC	33.5	42.8	52.2	31.9	41.3	50.6	30.0	39.3	48.6	27.8	36.9	45.9		
	76	TC	—	87.5	87.5	—	83.3	83.3	—	77.7	77.7	—	70.9	70.9		
		SHC	—	35.0	44.9	—	33.5	43.4	—	31.6	41.5	—	29.3	39.1		
	2100 Cfm	EAT (wb)	58	TC	68.9	68.9	77.7	65.9	65.9	74.3	62.5	62.5	70.5	58.7	58.7	66.2
				SHC	60.1	68.9	77.7	57.4	65.9	74.3	54.5	62.5	70.5	51.2	58.7	66.2
62			TC	70.9	70.9	76.9	67.1	67.1	75.0	63.0	63.0	72.5	58.7	58.7	68.7	
			SHC	55.6	66.3	76.9	53.8	64.4	75.0	51.6	62.1	72.5	48.7	58.7	68.7	
67			TC	77.8	77.8	77.8	73.7	73.7	73.7	69.2	69.2	69.2	64.0	64.0	64.0	
			SHC	45.4	56.1	66.8	43.7	54.4	65.2	41.8	52.5	63.2	39.6	50.2	60.7	
72		TC	84.5	84.5	84.5	80.3	80.3	80.3	75.1	75.1	75.1	68.8	68.8	68.8		
		SHC	34.5	45.2	55.9	32.9	43.5	54.2	30.9	41.4	52.0	28.5	38.7	48.9		
76		TC	—	89.2	89.2	—	84.7	84.7	—	78.8	78.8	—	71.6	71.6		
		SHC	—	36.3	47.8	—	34.7	46.0	—	32.6	43.7	—	30.1	40.9		
2400 Cfm		EAT (wb)	58	TC	72.0	72.0	81.2	68.7	68.7	77.5	65.2	65.2	73.5	61.1	61.1	68.9
				SHC	62.8	72.0	81.2	60.0	68.7	77.5	56.9	65.2	73.5	53.3	61.1	68.9
	62		TC	72.8	72.8	82.8	68.9	68.9	80.7	65.2	65.2	76.4	61.2	61.2	71.6	
			SHC	59.1	71.0	82.8	57.2	68.9	80.7	54.1	65.2	76.4	50.7	61.2	71.6	
	67		TC	79.4	79.4	79.4	75.2	75.2	75.2	70.5	70.5	70.5	65.1	65.1	65.3	
			SHC	47.7	59.8	71.8	46.0	58.1	70.2	44.0	56.0	68.1	41.6	53.5	65.3	
	72	TC	86.0	86.0	86.0	81.6	81.6	81.6	76.1	76.1	76.1	69.6	69.6	69.6		
		SHC	35.3	47.2	59.2	33.7	45.6	57.5	31.7	43.3	55.0	29.1	40.3	51.4		
	76	TC	—	90.3	90.3	—	85.7	85.7	—	79.6	79.6	—	72.1	72.1		
		SHC	—	37.3	49.8	—	35.6	48.0	—	33.5	45.6	—	30.8	42.5		
	2700 Cfm	EAT (wb)	58	TC	60.3	60.3	74.1	71.1	71.1	80.2	67.4	67.4	76.0	63.0	63.0	71.1
				SHC	46.4	60.3	74.1	62.0	71.1	80.2	58.8	67.4	76.0	55.0	63.0	71.1
62			TC	65.4	65.4	69.3	71.2	71.2	83.3	67.5	67.5	79.0	63.1	63.1	73.8	
			SHC	41.0	55.1	69.3	59.0	71.2	83.3	55.9	67.5	79.0	52.3	63.1	73.8	
67			TC	72.7	72.7	72.7	76.3	76.3	76.3	71.5	71.5	72.6	65.8	65.8	69.4	
			SHC	33.8	48.0	62.2	48.2	61.6	74.9	46.1	59.3	72.6	43.5	56.5	69.4	
72		TC	79.7	79.7	79.7	82.5	82.5	82.5	76.9	76.9	76.9	70.1	70.1	70.1		
		SHC	25.8	40.2	54.6	34.5	47.5	60.5	32.3	45.0	57.7	29.7	41.7	53.8		
76		TC	—	85.1	85.1	—	86.4	86.4	—	80.2	80.2	—	72.5	72.5		
		SHC	—	33.5	48.4	—	36.5	49.9	—	34.3	47.3	—	31.5	44.0		
3000 Cfm		EAT (wb)	58	TC	64.9	64.9	78.8	73.1	73.1	82.5	69.2	69.2	78.0	64.5	64.5	72.7
				SHC	51.1	64.9	78.8	63.8	73.1	82.5	60.3	69.2	78.0	56.2	64.5	72.7
	62		TC	68.7	68.7	76.5	73.2	73.2	85.7	69.2	69.2	81.0	64.5	64.5	75.5	
			SHC	45.5	61.0	76.5	60.7	73.2	85.7	57.4	69.2	81.0	53.5	64.5	75.5	
	67		TC	75.6	75.6	75.6	77.2	77.2	79.4	72.2	72.2	76.8	66.3	66.3	73.0	
			SHC	36.6	52.2	67.7	50.2	64.8	79.4	48.0	62.4	76.8	45.1	59.1	73.0	
	72	TC	82.6	82.6	82.6	83.3	83.3	83.3	77.5	77.5	77.5	70.5	70.5	70.5		
		SHC	27.2	42.8	58.5	35.1	49.2	63.3	32.9	46.6	60.3	30.2	43.0	55.9		
	76	TC	—	87.5	87.5	—	86.9	86.9	—	80.6	80.6	—	72.8	72.8		
		SHC	—	35.0	51.5	—	37.3	51.6	—	35.0	48.9	—	32.1	45.3		

**LEGEND**

- Do not operate
- Cfm — Cubic feet per minute (supply air)
- EAT (db) — Entering Air Temperature (dry bulb)
- EAT (wb) — Entering Air Temperature (wet bulb)
- SHC — Sensible Heat Capacity (1000 Btuh) Gross
- TC — Total Capacity (1000 Btuh) Gross

NOTE: See Minimum-Maximum Airflow Ratings table on page 6. Do not operate outside these limits.

## COOLING CAPACITIES — 1-CIRCUIT/1-STAGE COOLING, 6 TONS (cont)

### 48TC 07 (6 TONS) — UNIT WITH HUMIDI-MIZER SYSTEM IN SUBCOOLING MODE

Temp (F) Air Ent. Condenser (Edb)		Air Entering Evaporator – CFM								
		80 dry bulb			80 dry bulb			80 dry bulb		
		72 wet bulb			67 wet bulb			62 wet bulb		
		2100	2400	2700	2100	2400	2700	2100	2400	2700
75	TC	86.7	89.9	92.8	79.3	82.3	84.9	71.9	74.6	77.0
	SHC	40.1	41.8	43.3	46.9	48.5	49.9	53.7	55.2	56.5
	kW	4.3	4.3	4.3	4.2	4.2	4.2	4.2	4.2	4.2
85	TC	79.5	82.6	85.4	72.5	75.3	77.9	65.4	68.0	70.3
	SHC	32.1	34.0	35.7	40.7	42.5	44.1	49.4	51.0	52.5
	kW	5.0	5.0	5.0	5.0	5.0	5.0	4.9	4.9	4.9
95	TC	72.4	75.3	78.1	65.6	68.3	70.8	58.8	61.3	63.6
	SHC	24.1	26.3	28.1	34.6	36.6	38.3	45.1	46.9	48.5
	kW	5.8	5.8	5.8	5.7	5.7	5.7	5.6	5.6	5.6
105	TC	65.2	68.1	70.7	58.7	61.4	63.8	52.3	54.7	56.8
	SHC	16.2	18.5	20.5	28.5	30.6	32.6	40.7	42.8	44.6
	kW	6.5	6.5	6.5	6.4	6.4	6.4	6.3	6.3	6.3
115	TC	58.0	60.8	63.3	51.9	54.4	56.7	45.7	48.0	50.1
	SHC	8.2	10.7	13.0	22.3	24.7	26.8	36.4	38.6	40.6
	kW	7.2	7.2	7.2	7.1	7.1	7.1	7.0	7.0	7.0

### 48TC 07 (6 TONS) — UNIT WITH HUMIDI-MIZER SYSTEM IN HOT GAS REHEAT MODE

Temp (F) Air Entering Condenser (Edb)		Air Entering Evaporator – CFM								
		75 dry bulb			75 dry bulb			75 dry bulb		
		62.5 wet bulb			64 wet bulb			65.3 wet bulb		
		(50% relative)			(55% relative)			(60% relative)		
		2100	2400	2700	2100	2400	2700	1750	2000	2700
80	TC	16.7	19.8	22.5	18.8	21.9	24.7	16.2	19.4	26.7
	SHC	0.6	0.6	0.6	-0.4	-0.4	-0.4	-1.3	-1.3	-1.3
	kW	4.0	4.0	4.0	4.0	4.0	4.0	4.0	4.0	4.0
75	TC	17.7	20.6	23.1	19.6	22.6	25.3	17.3	20.3	27.1
	SHC	0.6	0.6	0.6	-0.3	-0.3	-0.3	-1.2	-1.2	-1.2
	kW	4.0	4.0	4.0	4.0	4.0	4.0	4.0	4.0	4.0
70	TC	18.6	21.3	23.7	20.5	23.3	25.8	18.3	21.1	27.6
	SHC	0.7	0.7	0.7	-0.2	-0.2	-0.2	-1.0	-1.0	-1.0
	kW	4.0	4.0	4.0	4.1	4.1	4.1	4.1	4.1	4.1
60	TC	20.5	22.9	25.0	22.2	24.7	26.8	20.4	22.8	28.5
	SHC	0.7	0.7	0.7	-0.0	-0.0	-0.0	-0.7	-0.7	-0.7
	kW	4.1	4.1	4.1	4.1	4.1	4.1	4.1	4.1	4.1
50	TC	22.4	24.4	26.2	24.0	26.0	27.9	22.4	24.5	29.3
	SHC	0.8	0.8	0.8	0.1	0.1	0.1	-0.4	-0.4	-0.4
	kW	4.1	4.1	4.1	4.1	4.1	4.1	4.2	4.2	4.2
40	TC	24.3	25.9	27.4	25.7	27.4	28.9	24.5	26.3	30.2
	SHC	0.8	0.8	0.8	0.3	0.3	0.3	-0.1	-0.1	-0.1
	kW	4.1	4.1	4.1	4.2	4.2	4.2	4.2	4.2	4.2

#### LEGEND

<b>Edb</b>	— Entering Dry-Bulb
<b>Ewb</b>	— Entering Wet-Bulb
<b>kW</b>	— Compressor Motor Power Input
<b>ldb</b>	— Leaving Wet-Bulb
<b>lwb</b>	— Leaving Wet-Bulb
<b>SHC</b>	— Sensible Heat Capacity (1000 Btuh) Gross
<b>TC</b>	— Total Capacity (1000 Btuh) Gross

#### NOTES:

1. Direct interpolation is permissible. Do not extrapolate.
2. The following formulas may be used:

$$t_{ldb} = t_{edb} - \frac{\text{sensible capacity (Btuh)}}{1.10 \times \text{cfm}}$$

$t_{lwb}$  = Wet-bulb temperature corresponding to enthalpy of air leaving evaporator coil ( $h_{lwb}$ )

$$h_{lwb} = h_{ewb} - \frac{\text{total capacity (Btuh)}}{4.5 \times \text{cfm}}$$

Where:  $h_{ewb}$  = Enthalpy of air entering evaporator coil



**COOLING CAPACITIES — 2-CIRCUIT/2-STAGE COOLING, 7.5 TONS**

48TC-D08 (RTPF and Novation®)			AMBIENT TEMPERATURE (F)													
			85			95			105			115				
			EAT (db)			EAT (db)			EAT (db)			EAT (db)				
			75	80	85	75	80	85	75	80	85	75	80	85		
2250 Cfm	EAT (wb)	58	TC	77.4	77.4	87.8	73.8	73.8	83.8	70.1	70.1	79.5	66.0	66.0	74.9	
			SHC	66.9	77.4	87.8	63.9	73.8	83.8	60.6	70.1	79.5	57.1	66.0	74.9	
		62	TC	82.2	82.2	83.9	77.5	77.5	81.7	72.6	72.6	79.2	67.3	67.3	76.4	
			SHC	60.8	72.4	83.9	58.6	70.1	81.7	56.3	67.7	79.2	53.6	65.0	76.4	
		67	TC	90.1	90.1	90.1	86.0	86.0	86.0	81.4	81.4	81.4	75.9	75.9	75.9	
			SHC	50.2	61.8	73.3	48.5	60.1	71.6	46.5	58.1	69.7	44.2	55.8	67.4	
	72	TC	98.0	98.0	98.0	94.0	94.0	94.0	89.5	89.5	89.5	84.3	84.3	84.3		
		SHC	39.1	50.7	62.4	37.5	49.2	60.9	35.8	47.5	59.2	33.8	45.5	57.2		
	76	TC	—	104.3	104.3	—	100.4	100.4	—	95.9	95.9	—	90.7	90.7		
		SHC	—	41.7	54.0	—	40.3	52.7	—	38.7	51.0	—	36.8	49.0		
	2625 Cfm	EAT (wb)	58	TC	82.1	82.1	93.2	78.4	78.4	89.0	74.4	74.4	84.4	70.0	70.0	79.5
				SHC	71.0	82.1	93.2	67.8	78.4	89.0	64.3	74.4	84.4	60.6	70.0	79.5
62			TC	84.9	84.9	91.8	80.4	80.4	89.5	75.4	75.4	86.7	70.2	70.2	82.9	
			SHC	65.4	78.6	91.8	63.2	76.3	89.5	60.6	73.7	86.7	57.6	70.2	82.9	
67			TC	92.5	92.5	92.5	88.3	88.3	88.3	83.6	83.6	83.6	78.3	78.3	78.3	
			SHC	53.0	66.3	79.5	51.3	64.6	78.0	49.4	62.8	76.1	47.2	60.6	73.9	
72		TC	100.4	100.4	100.4	96.4	96.4	96.4	91.7	91.7	91.7	86.4	86.4	86.4		
		SHC	40.2	53.5	66.7	38.7	52.0	65.3	36.9	50.3	63.7	35.0	48.4	61.8		
76		TC	—	106.5	106.5	—	102.6	102.6	—	98.0	98.0	—	92.7	92.7		
		SHC	—	43.3	57.6	—	41.8	55.9	—	40.2	54.1	—	38.4	52.2		
3000 Cfm		EAT (wb)	58	TC	85.7	85.7	97.3	82.2	82.2	93.3	78.0	78.0	88.6	73.5	73.5	83.4
				SHC	74.1	85.7	97.3	71.1	82.2	93.3	67.5	78.0	88.6	63.6	73.5	83.4
	62		TC	86.9	86.9	98.7	82.8	82.8	96.4	78.2	78.2	92.3	73.6	73.6	86.9	
			SHC	69.3	84.0	98.7	67.2	81.8	96.4	64.1	78.2	92.3	60.3	73.6	86.9	
	67		TC	94.3	94.3	94.3	90.1	90.1	90.1	85.2	85.2	85.2	79.8	79.8	80.1	
			SHC	55.6	70.5	85.4	54.0	68.9	83.9	52.1	67.1	82.2	49.9	65.0	80.1	
	72	TC	102.2	102.2	102.2	98.1	98.1	98.1	93.3	93.3	93.3	87.9	87.9	87.9		
		SHC	41.2	56.0	70.7	39.7	54.6	69.5	38.0	53.0	68.0	36.0	51.1	66.2		
	76	TC	—	108.1	108.1	—	104.2	104.2	—	99.5	99.5	—	94.2	94.2		
		SHC	—	44.5	60.2	—	43.2	58.7	—	41.6	57.0	—	39.8	55.2		
	3375 Cfm	EAT (wb)	58	TC	88.5	88.5	100.4	85.0	85.0	96.4	81.0	81.0	92.0	76.5	76.5	86.8
				SHC	76.5	88.5	100.4	73.5	85.0	96.4	70.1	81.0	92.0	66.1	76.5	86.8
62			TC	88.9	88.9	103.9	85.1	85.1	100.4	81.1	81.1	95.7	76.5	76.5	90.3	
			SHC	72.3	88.1	103.9	69.7	85.1	100.4	66.5	81.1	95.7	62.7	76.5	90.3	
67			TC	95.8	95.8	95.8	91.5	91.5	91.5	86.6	86.6	87.9	81.1	81.1	85.8	
			SHC	58.0	74.4	90.9	56.4	73.0	89.6	54.6	71.3	87.9	52.4	69.1	85.8	
72		TC	103.6	103.6	103.6	99.4	99.4	99.4	94.6	94.6	94.6	89.1	89.1	89.1		
		SHC	42.0	58.3	74.5	40.6	57.0	73.4	38.9	55.5	72.0	37.0	53.7	70.3		
76		TC	—	109.2	109.2	—	105.4	105.4	—	100.7	100.7	—	95.3	95.3		
		SHC	—	45.6	62.6	—	44.4	61.3	—	42.8	59.7	—	41.0	58.0		
3750 Cfm		EAT (wb)	58	TC	90.8	90.8	103.0	87.3	87.3	99.1	83.3	83.3	94.5	78.8	78.8	89.4
				SHC	78.5	90.8	103.0	75.5	87.3	99.1	72.0	83.3	94.5	68.2	78.8	89.4
	62		TC	90.9	90.9	107.2	87.4	87.4	103.1	83.3	83.3	98.4	78.9	78.9	93.1	
			SHC	74.5	90.9	107.2	71.6	87.4	103.1	68.3	83.3	98.4	64.7	78.9	93.1	
	67		TC	97.0	97.0	97.0	92.6	92.6	95.1	87.6	87.6	93.4	82.1	82.1	91.2	
			SHC	60.3	78.2	96.2	58.8	76.9	95.1	56.9	75.2	93.4	54.8	73.0	91.2	
	72	TC	104.7	104.7	104.7	100.5	100.5	100.5	95.6	95.6	95.6	90.1	90.1	90.1		
		SHC	42.9	60.5	78.1	41.4	59.3	77.1	39.8	57.8	75.9	37.9	56.1	74.3		
	76	TC	—	110.2	110.2	—	106.2	106.2	—	101.6	101.6	—	96.1	96.1		
		SHC	—	46.7	64.8	—	45.4	63.6	—	44.0	62.3	—	42.2	60.6		

LEGEND

- Do not operate
- Cfm — Cubic feet per minute (supply air)
- EAT (db) — Entering Air Temperature (dry bulb)
- EAT (wb) — Entering Air Temperature (wet bulb)
- SHC — Sensible Heat Capacity (1000 Btuh) Gross
- TC — Total Capacity (1000 Btuh) Gross

NOTE: See Minimum-Maximum Airflow Ratings table on page 6. Do not operate outside these limits.

## COOLING CAPACITIES — 2-CIRCUIT/2-STAGE COOLING, 7.5 TONS (cont)

### 48TC 08 COOLING CAPACITIES, RTPF UNIT WITH HUMIDI-MIZER SYSTEM IN SUBCOOLING MODE

Temp (F) Air Ent. Condenser (Edb)		AIR ENTERING EVAPORATOR - CFM								
		2250/0.05			3000/0.07			3750/0.09		
		Air Entering Evaporator - Ewb (F)								
		72	67	62	72	67	62	72	67	62
75	TC	103.05	93.02	83.60	109.77	99.52	90.08	114.01	103.69	95.19
	SHC	43.66	55.34	67.09	50.99	66.29	81.31	57.49	76.27	92.20
	kW	4.90	4.83	4.77	4.82	4.88	4.96	4.99	4.91	4.85
85	TC	95.39	85.83	76.88	101.59	91.89	82.95	105.53	95.76	87.77
	SHC	36.42	48.47	60.60	43.24	58.99	74.40	49.44	68.68	84.90
	kW	5.49	5.42	5.36	5.40	5.47	5.54	5.58	5.50	5.44
95	TC	87.48	78.44	69.97	93.21	84.05	75.61	96.84	87.63	80.14
	SHC	28.98	41.46	53.97	35.32	51.53	67.34	41.21	60.92	77.41
	kW	6.16	6.09	6.03	6.08	6.14	6.21	6.24	6.17	6.11
105	TC	79.35	70.83	62.84	84.57	75.96	68.04	87.88	79.23	72.26
	SHC	21.34	34.26	47.18	27.17	43.86	60.08	32.73	52.95	69.70
	kW	6.93	6.86	6.81	6.85	6.91	6.97	7.00	6.93	6.88
115	TC	70.87	62.89	55.42	75.58	67.54	60.15	78.56	70.51	64.06
	SHC	13.40	26.79	40.14	18.70	35.89	52.54	23.94	44.68	61.67
	kW	7.79	7.74	7.69	7.73	7.78	7.83	7.86	7.80	7.76

### 48TC 08 COOLING CAPACITIES, RTPF UNIT WITH HUMIDI-MIZER SYSTEM IN HOT GAS REHEAT MODE

Temp (F) Air Ent. Condenser (Edb)		Air Entering Evaporator - Ewb (F)								
		75 Dry Bulb			75 Dry Bulb			75 Dry Bulb		
		62.5 Wet Bulb			64 Wet Bulb			65.3 Wet Bulb		
		(50% Relative)			(56% Relative)			(60% Relative)		
		Air Entering Evaporator - CFM								
		2250	3000	3750	2250	3000	3750	2250	3000	3750
80	TC	27.60	32.75	30.19	40.09	39.43	37.73	45.06	45.25	44.25
	SHC	-3.12	5.20	6.71	3.75	5.24	6.75	3.77	5.26	6.78
	kW	4.56	4.51	4.46	4.63	4.60	4.56	4.70	4.67	4.64
75	TC	35.40	33.78	31.20	41.14	40.51	38.80	46.15	46.37	45.38
	SHC	4.67	6.17	7.69	4.71	6.21	7.73	4.74	6.24	7.76
	kW	4.41	4.36	4.39	4.41	4.36	4.36	4.41	4.39	4.36
70	TC	36.36	34.71	32.18	42.10	41.47	39.77	47.08	47.31	46.32
	SHC	5.63	7.14	8.66	5.67	7.18	8.71	5.70	7.21	8.74
	kW	4.43	4.49	4.41	4.44	4.40	4.39	4.49	4.47	4.44
60	TC	38.25	36.64	34.15	43.97	43.37	41.72	48.98	49.22	48.26
	SHC	7.56	9.09	10.62	7.60	9.13	10.66	7.62	9.15	10.69
	kW	4.56	4.55	4.43	4.57	4.53	4.46	4.56	4.55	4.50
50	TC	40.15	38.60	36.14	45.95	45.37	43.73	50.57	50.97	49.56
	SHC	9.48	11.03	12.58	9.52	11.07	12.62	9.54	11.10	12.64
	kW	4.63	4.52	4.38	4.45	4.41	4.33	5.25	4.91	5.60
40	TC	42.18	40.62	38.11	47.80	47.25	45.43	52.65	52.75	51.83
	SHC	11.41	12.98	14.54	11.45	13.02	14.58	11.47	13.04	14.60
	kW	4.32	4.37	4.37	4.65	4.60	4.89	4.96	5.20	5.12

#### LEGEND

**Edb** — Entering Dry-Bulb  
**Ewb** — Entering Wet-Bulb  
**kW** — Compressor Motor Power Input  
**ldb** — Leaving Dry-Bulb  
**lwb** — Leaving Wet-Bulb  
**SHC** — Sensible Heat Capacity (1000 Btuh) Gross  
**TC** — Total Capacity (1000 Btuh) Gross

#### NOTES:

- Direct interpolation is permissible. Do not extrapolate.
- The following formulas may be used:

$$t_{ldb} = t_{edb} - \frac{\text{sensible capacity (Btuh)}}{1.10 \times \text{cfm}}$$

$t_{lwb}$  = Wet-bulb temperature corresponding to enthalpy of air leaving evaporator coil ( $h_{lwb}$ )

$$h_{lwb} = h_{ewb} - \frac{\text{total capacity (Btuh)}}{4.5 \times \text{cfm}}$$

Where:  $h_{ewb}$  = Enthalpy of air entering evaporator coil





**COOLING CAPACITIES — 1-CIRCUIT 2-STAGE COOLING, 7.5 TONS**

48TC-M08* (RTPF)			AMBIENT TEMPERATURE (F)													
			85			95			105			115				
			EAT (db)			EAT (db)			EAT (db)			EAT (db)				
			75	80	85	75	80	85	75	80	85	75	80	85		
2250 Cfm	EAT (wb)	58	TC	79.6	79.6	87.7	76.2	76.2	86.4	73.1	73.1	82.8	69.5	69.5	78.8	
			SHC	67.5	77.6	87.7	66.0	76.2	86.4	63.2	73.0	82.8	60.2	69.5	78.8	
		62	TC	85.6	85.6	85.6	81.6	81.6	81.6	77.3	77.3	78.5	72.6	72.6	76.4	
			SHC	60.8	71.5	82.1	59.0	69.7	80.4	57.0	67.8	78.5	54.9	65.7	76.4	
		67	TC	94.5	94.5	94.5	90.0	90.0	90.0	85.2	85.2	85.2	80.0	80.0	80.0	
			SHC	50.5	61.0	71.5	48.6	59.2	69.9	46.7	57.3	68.0	44.6	55.3	66.1	
	72	TC	104.2	104.2	104.2	99.3	99.3	99.3	94.0	94.0	94.0	88.2	88.2	88.2		
		SHC	40.3	50.2	60.0	38.4	48.4	58.5	36.3	46.6	56.8	34.1	44.5	55.0		
	76	TC	—	112.4	112.4	—	107.3	107.3	—	101.6	101.6	—	95.3	95.3		
		SHC	—	41.6	54.0	—	39.2	51.6	—	37.2	49.6	—	35.5	47.9		
	2625 Cfm	EAT (wb)	58	TC	84.7	84.7	92.8	80.9	80.9	91.6	77.4	77.4	87.7	73.5	73.5	83.3
				SHC	71.6	82.2	92.8	70.1	80.9	91.6	67.0	77.4	87.7	63.7	73.5	83.3
62			TC	88.7	88.7	90.4	84.4	84.4	88.6	79.8	79.8	86.3	74.8	74.8	83.6	
			SHC	65.7	78.0	90.4	63.8	76.2	88.6	61.7	74.0	86.3	59.2	71.4	83.6	
67			TC	97.6	97.6	97.6	92.9	92.9	92.9	87.8	87.8	87.8	82.3	82.3	82.3	
			SHC	53.8	66.1	78.4	51.9	64.2	76.6	49.9	62.3	74.7	47.7	60.2	72.7	
72		TC	107.5	107.5	107.5	102.3	102.3	102.3	96.7	96.7	96.7	90.6	90.6	90.6		
		SHC	41.7	53.5	65.3	39.8	51.7	63.7	37.7	49.8	61.9	35.5	47.7	60.0		
76		TC	—	116.1	116.1	—	110.4	110.4	—	104.3	104.3	—	97.7	97.7		
		SHC	—	42.7	57.3	—	41.2	55.8	—	39.4	48.5	—	37.4	48.3		
3000 Cfm		EAT (wb)	58	TC	87.7	87.7	99.3	84.3	84.3	95.5	80.5	80.5	91.2	76.4	76.4	86.5
				SHC	76.0	87.7	99.3	73.1	84.3	95.5	69.8	80.5	91.2	66.2	76.4	86.5
	62		TC	90.8	90.8	97.0	86.3	86.3	94.8	81.6	81.6	92.1	76.8	76.8	88.4	
			SHC	69.6	83.3	97.0	67.5	81.1	94.8	65.1	78.6	92.1	62.2	75.3	88.4	
	67		TC	99.8	99.8	99.8	94.9	94.9	94.9	89.6	89.6	89.6	83.8	83.8	83.8	
			SHC	56.5	70.3	84.0	54.6	68.4	82.3	52.5	66.4	80.3	50.3	64.3	78.2	
	72	TC	109.8	109.8	109.8	104.3	104.3	104.3	98.5	98.5	98.5	92.1	92.1	92.1		
		SHC	42.9	56.3	69.6	40.9	54.4	67.9	38.8	52.5	66.1	36.6	50.3	64.1		
	76	TC	—	118.4	118.4	—	112.5	112.5	—	106.1	106.1	—	99.3	99.3		
		SHC	—	44.6	61.1	—	42.8	54.0	—	40.9	53.1	—	38.9	51.7		
	3375 Cfm	EAT (wb)	58	TC	91.2	91.2	103.3	87.6	87.6	99.2	83.6	83.6	94.6	79.2	79.2	89.7
				SHC	79.2	91.2	103.3	76.0	87.6	99.2	72.5	83.6	94.6	68.7	79.2	89.7
62			TC	92.8	92.8	103.4	88.4	88.4	100.6	84.0	84.0	96.7	79.9	79.9	90.6	
			SHC	73.5	88.5	103.4	71.0	85.8	100.6	68.1	82.4	96.7	64.0	77.3	90.6	
67			TC	101.8	101.8	101.8	96.7	96.7	96.7	91.2	91.2	91.2	85.2	85.2	85.2	
			SHC	59.4	74.9	90.3	57.5	73.0	88.5	55.4	70.9	86.5	53.1	68.7	84.3	
72		TC	111.9	111.9	111.9	106.2	106.2	106.2	100.1	100.1	100.1	93.5	93.5	93.5		
		SHC	44.2	59.3	74.4	42.2	57.4	72.6	40.0	55.4	70.7	37.8	53.2	68.7		
76		TC	—	120.5	120.5	—	114.4	114.4	—	107.8	107.8	—	100.7	100.7		
		SHC	—	46.4	59.4	—	44.5	58.3	—	42.6	56.9	—	40.5	55.2		
3750 Cfm		EAT (wb)	58	TC	93.9	93.9	106.3	90.1	90.1	101.9	85.8	85.8	97.2	81.2	81.2	92.0
				SHC	81.5	93.9	106.3	78.2	90.1	101.9	74.5	85.8	97.2	70.5	81.2	92.0
	62		TC	94.5	94.5	107.9	90.2	90.2	105.9	86.7	86.7	97.9	81.5	81.5	94.8	
			SHC	76.2	92.1	107.9	74.3	90.1	105.9	69.3	83.6	97.9	66.6	80.7	94.8	
	67		TC	103.3	103.3	103.3	98.0	98.0	98.0	92.3	92.3	92.3	86.2	86.2	89.3	
			SHC	61.9	78.7	95.6	59.9	76.8	93.7	57.8	74.7	91.6	55.5	72.4	89.3	
	72	TC	113.3	113.3	113.3	107.5	107.5	107.5	101.3	101.3	101.3	94.5	94.5	94.5		
		SHC	45.2	61.8	78.3	43.2	59.9	76.5	41.1	57.8	74.6	38.8	55.6	72.5		
	76	TC	—	122.0	122.0	—	115.8	115.8	—	109.0	109.0	—	101.7	101.7		
		SHC	—	47.8	62.8	—	45.9	61.4	—	44.0	59.8	—	41.8	58.1		

**LEGEND**

- Do not operate
- Cfm** — Cubic feet per minute (supply air)
- EAT (db)** — Entering Air Temperature (dry bulb)
- EAT (wb)** — Entering Air Temperature (wet bulb)
- SHC** — Sensible Heat Capacity (1000 Btuh) Gross
- TC** — Total Capacity (1000 Btuh) Gross

\* Not available in 208/230/3/60 and 460/3/60 models with high static indoor fan motor.

NOTE: See Minimum-Maximum Airflow Ratings table on page 6. Do not operate outside these limits.

## COOLING CAPACITIES — 2-CIRCUIT/2-STAGE COOLING, 8.5 TONS

48TC-D09 (RTPF)				AMBIENT TEMPERATURE (F)												
				85			95			105			115			
				EAT (db)			EAT (db)			EAT (db)			EAT (db)			
				75	80	85	75	80	85	75	80	85	75	80	85	
2550 Cfm	EAT (wb)	58	TC	89.7	89.7	101.6	85.2	85.2	96.5	79.6	79.6	90.1	73.8	73.8	83.6	
			SHC	77.8	89.7	101.6	73.9	85.2	96.5	69.0	79.6	90.1	64.0	73.8	83.6	
		62	TC	94.3	94.3	97.9	88.7	88.7	95.2	81.3	81.3	91.5	74.3	74.3	86.5	
			SHC	71.0	84.4	97.9	68.2	81.7	95.2	64.7	78.1	91.5	60.6	73.6	86.5	
		67	TC	105.0	105.0	105.0	99.3	99.3	99.3	92.2	92.2	92.2	84.1	84.1	84.1	
			SHC	59.0	72.6	86.1	56.6	70.1	83.7	53.6	67.1	80.7	50.3	63.8	77.3	
	72	TC	115.9	115.9	115.9	110.4	110.4	110.4	104.2	104.2	104.2	96.0	96.0	96.0		
		SHC	46.4	60.0	73.6	44.3	57.9	71.5	41.9	55.5	69.1	38.8	52.4	65.9		
	76	TC	—	123.7	123.7	—	118.3	118.3	—	112.4	112.4	—	105.7	105.7		
		SHC	—	49.3	63.3	—	47.3	61.4	—	45.3	59.3	—	42.9	56.7		
	2975 Cfm	EAT (wb)	58	TC	95.3	95.3	107.9	90.7	90.7	102.7	84.8	84.8	96.1	78.7	78.7	89.1
				SHC	82.6	95.3	107.9	78.6	90.7	102.7	73.5	84.8	96.1	68.2	78.7	89.1
62			TC	97.9	97.9	107.8	92.1	92.1	104.7	85.4	85.4	99.4	78.8	78.8	92.8	
			SHC	76.7	92.2	107.8	73.9	89.3	104.7	69.6	84.5	99.4	64.8	78.8	92.8	
67			TC	108.5	108.5	108.5	102.6	102.6	102.6	95.4	95.4	95.4	86.9	86.9	86.9	
			SHC	62.8	78.4	94.1	60.4	76.0	91.7	57.4	73.1	88.8	54.0	69.7	85.3	
72		TC	119.1	119.1	119.1	113.5	113.5	113.5	107.2	107.2	107.2	99.2	99.2	99.2		
		SHC	47.9	63.5	79.2	45.8	61.5	77.1	43.5	59.2	74.9	40.6	56.3	72.0		
76		TC	—	126.4	126.4	—	120.8	120.8	—	114.8	114.8	—	108.2	108.2		
		SHC	—	51.1	67.4	—	49.2	65.3	—	47.0	63.0	—	44.8	60.7		
3400 Cfm		EAT (wb)	58	TC	100.0	100.0	113.3	95.2	95.2	107.9	89.3	89.3	101.1	82.9	82.9	93.9
				SHC	86.7	100.0	113.3	82.6	95.2	107.9	77.4	89.3	101.1	71.8	82.9	93.9
	62		TC	101.1	101.1	115.8	95.7	95.7	111.7	89.4	89.4	105.3	83.0	83.0	97.7	
			SHC	81.5	98.7	115.8	78.2	94.9	111.7	73.5	89.4	105.3	68.2	83.0	97.7	
	67		TC	111.1	111.1	111.1	105.1	105.1	105.1	97.8	97.8	97.8	89.1	89.1	93.0	
			SHC	66.2	83.9	101.6	63.9	81.6	99.3	61.0	78.7	96.5	57.5	75.3	93.0	
	72	TC	121.3	121.3	121.3	115.6	115.6	115.6	109.4	109.4	109.4	101.5	101.5	101.5		
		SHC	49.2	66.7	84.3	47.1	64.7	82.3	44.9	62.5	80.2	42.1	59.9	77.7		
	76	TC	—	128.3	128.3	—	122.6	122.6	—	116.3	116.3	—	109.7	109.7		
		SHC	—	52.7	70.7	—	50.7	68.6	—	48.6	66.4	—	46.4	64.2		
	3825 Cfm	EAT (wb)	58	TC	104.0	104.0	117.8	99.1	99.1	112.3	93.2	93.2	105.5	86.5	86.5	97.9
				SHC	90.2	104.0	117.8	86.0	99.1	112.3	80.8	93.2	105.5	75.0	86.5	97.9
62			TC	104.2	104.2	122.7	99.3	99.3	116.9	93.3	93.3	109.8	86.6	86.6	101.9	
			SHC	85.7	104.2	122.7	81.7	99.3	116.9	76.7	93.3	109.8	71.2	86.6	101.9	
67			TC	113.1	113.1	113.1	107.1	107.1	107.1	99.9	99.9	103.8	91.0	91.0	100.3	
			SHC	69.4	89.1	108.8	67.1	86.8	106.5	64.3	84.1	103.8	60.9	80.6	100.3	
72		TC	123.0	123.0	123.0	117.2	117.2	117.2	110.9	110.9	110.9	103.3	103.3	103.3		
		SHC	50.3	69.7	89.0	48.3	67.7	87.1	46.1	65.6	85.2	43.5	63.3	83.0		
76		TC	—	129.7	129.7	—	124.0	124.0	—	117.5	117.5	—	110.8	110.8		
		SHC	—	54.0	73.7	—	52.1	71.7	—	50.0	69.5	—	47.8	67.4		
4250 Cfm		EAT (wb)	58	TC	107.4	107.4	121.7	102.5	102.5	116.1	96.5	96.5	109.3	89.5	89.5	101.4
				SHC	93.1	107.4	121.7	88.9	102.5	116.1	83.7	96.5	109.3	77.6	89.5	101.4
	62		TC	107.5	107.5	126.6	102.6	102.6	120.8	96.6	96.6	113.7	89.6	89.6	105.5	
			SHC	88.4	107.5	126.6	84.4	102.6	120.8	79.5	96.6	113.7	73.7	89.6	105.5	
	67		TC	114.7	114.7	115.6	108.7	108.7	113.5	101.7	101.7	110.8	92.6	92.6	107.2	
			SHC	72.5	94.0	115.6	70.2	91.8	113.5	67.5	89.2	110.8	64.0	85.6	107.2	
	72	TC	124.3	124.3	124.3	118.5	118.5	118.5	112.1	112.1	112.1	104.7	104.7	104.7		
		SHC	51.3	72.4	93.4	49.3	70.5	91.7	47.2	68.5	89.9	44.7	66.4	88.1		
	76	TC	—	130.7	130.7	—	125.0	125.0	—	118.5	118.5	—	111.6	111.6		
		SHC	—	55.3	76.5	—	53.5	74.6	—	51.3	72.4	—	49.2	70.3		

### LEGEND

- Do not operate
- Cfm — Cubic feet per minute (supply air)
- EAT (db) — Entering Air Temperature (dry bulb)
- EAT (wb) — Entering Air Temperature (wet bulb)
- SHC — Sensible Heat Capacity (1000 Btuh) Gross
- TC — Total Capacity (1000 Btuh) Gross

NOTE: See Minimum-Maximum Airflow Ratings on page 6. Do not operate outside these limits.



## COOLING CAPACITIES — 2-CIRCUIT/2-STAGE COOLING, 8.5 TONS (cont)

### 48TC 09 COOLING CAPACITIES, RTPF UNIT WITH HUMIDI-MIZER SYSTEM IN SUBCOOLING MODE

Temp (F) Air Ent. Condenser (Edb)		Air Entering Evaporator - CFM								
		2550/0.04			3400/0.05			4250/0.07		
		Air Entering Evaporator - Ewb (F)								
		72	67	62	72	67	62	72	67	62
75	TC	119.20	107.40	96.40	127.00	115.00	103.90	131.90	119.80	109.50
	SHC	50.60	63.90	77.40	59.20	76.70	94.20	66.80	88.40	108.20
	kW	5.67	5.57	5.47	5.54	5.63	5.74	5.79	5.68	5.59
85	TC	110.40	99.20	88.80	117.60	106.30	95.80	122.20	110.80	101.10
	SHC	42.40	56.20	70.10	50.40	68.50	86.40	57.70	79.90	99.90
	kW	6.33	6.23	6.14	6.20	6.30	6.40	6.45	6.34	6.25
95	TC	101.40	90.80	80.90	108.10	97.30	87.40	112.30	101.50	92.40
	SHC	34.00	48.20	62.60	41.50	60.00	78.40	48.40	71.10	91.50
	kW	7.08	6.99	6.90	6.96	7.05	7.16	7.20	7.09	7.01
105	TC	92.00	82.10	72.70	98.20	88.10	78.70	102.10	91.90	83.40
	SHC	25.30	40.10	54.90	32.20	51.30	70.20	38.80	62.10	82.70
	kW	7.94	7.85	7.77	7.83	7.91	8.01	8.06	7.95	7.87
115	TC	82.40	73.00	64.20	88.00	78.50	69.70	91.50	81.90	74.10
	SHC	16.40	31.60	47.00	22.70	42.40	61.70	28.90	52.70	73.50
	kW	8.92	8.84	8.77	8.82	8.89	8.98	9.02	8.93	8.86

### 48TC 09 COOLING CAPACITIES, RTPF UNIT WITH HUMIDI-MIZER SYSTEM IN HOT GAS REHEAT MODE

Temp (F) Air Ent. Condenser (Edb)		Air Entering Evaporator - Ewb (F)								
		75 Dry Bulb			75 Dry Bulb			75 Dry Bulb		
		62.5 Wet Bulb			64 Wet Bulb			65.3 Wet Bulb		
		(50% Relative)			(56% Relative)			(60% Relative)		
		Air Entering Evaporator - Cfm								
		2550	3400	4250	2550	3400	4250	2550	3400	4250
80	TC	37.61	33.13	26.77	44.74	41.60	36.46	50.96	48.99	44.93
	SHC	-0.52	-0.63	-0.73	-0.46	-0.57	-0.67	-0.42	-0.53	-0.62
	kW	5.88	5.68	5.44	6.13	5.97	5.76	6.35	6.24	6.06
75	TC	38.71	34.24	27.86	45.84	42.73	37.59	52.05	50.11	46.06
	SHC	0.45	0.34	0.25	0.50	0.40	0.31	0.54	0.44	0.36
	kW	5.68	5.47	5.22	5.94	5.78	5.56	6.18	6.07	5.88
70	TC	39.70	35.25	28.83	46.80	43.70	38.59	52.97	51.04	47.02
	SHC	1.41	1.32	1.23	1.47	1.37	1.29	1.50	1.41	1.34
	kW	5.65	5.42	5.24	5.97	5.79	5.53	6.26	6.13	5.91
60	TC	41.77	37.33	30.76	48.86	45.80	40.71	55.00	53.10	49.12
	SHC	3.34	3.26	3.18	3.40	3.32	3.25	3.43	3.36	3.29
	kW	5.42	5.15	5.17	5.80	5.59	5.30	6.16	6.01	5.75
50	TC	43.83	39.27	32.61	50.92	47.89	42.70	57.04	55.16	51.22
	SHC	5.27	5.21	5.14	5.32	5.27	5.21	5.36	5.31	5.25
	kW	5.18	5.15	5.17	5.62	5.39	5.05	6.04	5.87	5.59
40	TC	45.75	41.13	34.50	53.08	50.00	44.64	59.24	57.40	53.44
	SHC	7.20	7.15	6.95	7.26	7.21	7.16	7.29	7.25	7.21
	kW	4.79	4.98	4.80	5.25	5.01	5.23	5.68	5.51	5.21

**LEGEND**

- Edb** — Entering Dry-Bulb
- Ewb** — Entering Wet-Bulb
- kW** — Compressor Motor Power Input
- ldb** — Leaving Dry-Bulb
- lwb** — Leaving Wet-Bulb
- SHC** — Sensible Heat Capacity (1000 Btuh) Gross
- TC** — Total Capacity (1000 Btuh) Gross

**NOTES:**

1. Direct interpolation is permissible. Do not extrapolate.
2. The following formulas may be used:

$$t_{ldb} = t_{edb} - \frac{\text{sensible capacity (Btuh)}}{1.10 \times \text{cfm}}$$

$t_{lwb}$  = Wet-bulb temperature corresponding to enthalpy of air leaving evaporator coil ( $h_{lwb}$ )

$$h_{lwb} = h_{ewb} - \frac{\text{total capacity (Btuh)}}{4.5 \times \text{cfm}}$$

Where:  $h_{ewb}$  = Enthalpy of air entering evaporator coil

## COOLING CAPACITIES — 1-CIRCUIT/SINGLE CIRCUIT 2-STAGE COOLING, 8.5 TONS

48TC-M09 (RTPF)				AMBIENT TEMPERATURE (F)												
				85			95			105			115			
				EAT (db)			EAT (db)			EAT (db)			EAT (db)			
				75	80	85	75	80	85	75	80	85	75	80	85	
2550 Cfm	EAT (wb)	58	TC	85.4	85.4	95.6	81.6	81.6	93.2	78.1	78.1	89.2	74.1	74.1	84.6	
			SHC	72.2	83.9	95.6	70.1	81.6	93.2	67.0	78.1	89.2	63.5	74.1	84.6	
		62	TC	91.1	91.1	91.1	86.5	86.5	88.6	81.7	81.7	86.7	76.2	76.2	84.1	
			SHC	65.0	77.7	90.5	63.0	75.8	88.6	61.0	73.8	86.7	58.5	71.3	84.1	
		67	TC	101.8	101.8	101.8	96.9	96.9	96.9	91.2	91.2	91.2	85.1	85.1	85.1	
			SHC	53.4	66.1	78.8	51.5	64.2	77.0	49.2	62.1	74.9	46.9	59.8	72.7	
	72	TC	113.4	113.4	113.4	107.8	107.8	107.8	101.7	101.7	101.7	94.9	94.9	94.9		
		SHC	41.7	54.0	66.4	39.6	52.1	64.6	37.3	50.0	62.6	34.9	47.7	60.4		
	76	TC	—	123.5	123.5	—	117.3	117.3	—	110.5	110.5	—	103.2	103.2		
		SHC	—	43.8	57.9	—	42.0	56.1	—	40.0	51.1	—	37.7	49.6		
	2975 Cfm	EAT (wb)	58	TC	91.0	91.0	103.7	87.5	87.5	99.7	83.4	83.4	95.1	79.0	79.0	90.0
				SHC	78.3	91.0	103.7	75.2	87.5	99.7	71.8	83.4	95.1	67.9	79.0	90.0
62			TC	94.9	94.9	100.9	90.0	90.0	98.5	84.6	84.6	95.8	79.3	79.3	92.8	
			SHC	71.4	86.1	100.9	69.0	83.7	98.5	66.5	81.2	95.8	63.9	78.4	92.8	
67			TC	105.6	105.6	105.6	100.2	100.2	100.2	94.2	94.2	94.2	87.8	87.8	87.8	
			SHC	57.8	72.6	87.4	55.7	70.6	85.4	53.4	68.4	83.3	51.0	66.0	80.9	
72		TC	117.4	117.4	117.4	111.4	111.4	111.4	104.8	104.8	104.8	97.6	97.6	97.6		
		SHC	43.9	58.4	73.0	41.7	56.4	71.1	39.4	54.2	68.9	36.9	51.8	66.6		
76		TC	—	127.4	127.4	—	120.9	120.9	—	113.7	113.7	—	106.0	106.0		
		SHC	—	46.7	59.3	—	44.7	58.2	—	42.5	56.5	—	40.2	54.5		
3400 Cfm		EAT (wb)	58	TC	95.6	95.6	108.9	91.7	91.7	104.4	87.4	87.4	99.5	82.6	82.6	94.0
				SHC	82.4	95.6	108.9	79.1	91.7	104.4	75.3	87.4	99.5	71.1	82.6	94.0
	62		TC	97.4	97.4	108.3	92.6	92.6	106.1	88.2	88.2	101.6	82.9	82.9	97.3	
			SHC	75.9	92.1	108.3	73.8	90.0	106.1	70.5	86.1	101.6	67.1	82.2	97.3	
	67		TC	108.2	108.2	108.2	102.5	102.5	102.5	96.3	96.3	96.3	89.6	89.6	89.6	
			SHC	61.3	77.9	94.6	59.2	75.9	92.5	56.8	73.6	90.3	54.3	71.1	87.9	
	72	TC	120.1	120.1	120.1	113.8	113.8	113.8	106.9	106.9	106.9	99.4	99.4	99.4		
		SHC	45.6	62.0	78.4	43.4	59.9	76.4	41.0	57.6	74.2	38.5	55.2	71.8		
	76	TC	—	130.2	130.2	—	123.4	123.4	—	115.9	115.9	—	107.8	107.8		
		SHC	—	48.9	64.1	—	46.8	62.5	—	44.6	60.5	—	42.2	58.4		
	3825 Cfm	EAT (wb)	58	TC	100.1	100.1	113.8	95.9	95.9	109.0	91.2	91.2	103.7	86.0	86.0	97.8
				SHC	86.3	100.1	113.8	82.7	95.9	109.0	78.6	91.2	103.7	74.1	86.0	97.8
62			TC	100.6	100.6	116.8	96.8	96.8	111.5	91.3	91.3	107.9	86.1	86.1	101.8	
			SHC	81.2	99.0	116.8	77.6	94.5	111.5	74.6	91.3	107.9	70.3	86.1	101.8	
67			TC	110.5	110.5	110.5	104.6	104.6	104.6	98.1	98.1	98.1	91.2	91.2	95.3	
			SHC	65.1	83.7	102.3	62.9	81.5	100.1	60.5	79.2	97.9	57.9	76.6	95.3	
72		TC	122.5	122.5	122.5	115.9	115.9	115.9	108.7	108.7	108.7	101.0	101.0	101.0		
		SHC	47.4	65.8	84.2	45.2	63.7	82.2	42.7	61.3	79.9	40.2	58.8	77.5		
76		TC	—	132.6	132.6	—	125.6	125.6	—	117.8	117.8	—	109.5	109.5		
		SHC	—	51.1	68.6	—	49.0	66.8	—	46.7	64.8	—	44.2	62.5		
4250 Cfm		EAT (wb)	58	TC	103.4	103.4	117.5	99.0	99.0	112.5	94.0	94.0	106.8	88.5	88.5	100.7
				SHC	89.3	103.4	117.5	85.5	99.0	112.5	81.2	94.0	106.8	76.4	88.5	100.7
	62		TC	104.2	104.2	120.3	99.1	99.1	117.0	94.1	94.1	111.2	88.6	88.6	104.7	
			SHC	83.9	102.1	120.3	81.1	99.1	117.0	77.0	94.1	111.2	72.5	88.6	104.7	
	67		TC	112.2	112.2	112.2	106.2	106.2	106.7	99.5	99.5	104.2	92.3	92.3	101.5	
			SHC	68.3	88.5	108.8	66.0	86.4	106.7	63.5	83.9	104.2	60.8	81.2	101.5	
	72	TC	124.2	124.2	124.2	117.5	117.5	117.5	110.1	110.1	110.1	102.2	102.2	102.2		
		SHC	48.9	69.0	89.2	46.6	66.9	87.1	44.1	64.5	84.8	41.5	61.9	82.3		
	76	TC	—	134.4	134.4	—	127.2	127.2	—	119.2	119.2	—	110.7	110.7		
		SHC	—	53.0	72.4	—	50.9	70.5	—	48.5	68.4	—	46.0	66.1		

**LEGEND**

- Do not operate
- Cfm** — Cubic feet per minute (supply air)
- EAT (db)** — Entering Air Temperature (dry bulb)
- EAT (wb)** — Entering Air Temperature (wet bulb)
- SHC** — Sensible Heat Capacity (1000 Btuh) Gross
- TC** — Total Capacity (1000 Btuh) Gross

NOTE: See Minimum-Maximum Airflow Ratings table on page 6. Do not operate outside these limits.



**COOLING CAPACITIES — 2-CIRCUIT/2-STAGE COOLING, 10 TONS**

48TC-D12 (RTPF and Novation®)			AMBIENT TEMPERATURE (F)													
			85			95			105			115				
			EAT (db)			EAT (db)			EAT (db)			EAT (db)				
			75	80	85	75	80	85	75	80	85	75	80	85		
3000 Cfm	EAT (wb)	58	TC	107.6	107.6	121.9	102.5	102.5	116.2	96.8	96.8	109.7	90.5	90.5	102.6	
			SHC	93.2	107.6	121.9	88.8	102.5	116.2	83.9	96.8	109.7	78.4	90.5	102.6	
		62	TC	113.6	113.6	116.5	107.1	107.1	113.4	99.7	99.7	109.8	91.8	91.8	104.9	
			SHC	84.6	100.6	116.5	81.5	97.4	113.4	78.0	93.9	109.8	73.7	89.3	104.9	
		67	TC	124.4	124.4	124.4	118.4	118.4	118.4	111.5	111.5	111.5	103.3	103.3	103.3	
			SHC	69.7	85.7	101.7	67.1	83.2	99.2	64.3	80.3	96.3	60.8	76.8	92.8	
	72	TC	135.8	135.8	135.8	129.7	129.7	129.7	122.8	122.8	122.8	115.0	115.0	115.0		
		SHC	54.3	70.4	86.6	52.0	68.1	84.2	49.3	65.4	81.6	46.4	62.5	78.6		
	76	TC	—	145.3	145.3	—	139.0	139.0	—	131.9	131.9	—	124.1	124.1		
		SHC	—	57.8	74.3	—	55.6	72.1	—	53.1	69.6	—	50.4	66.9		
	3500 Cfm	EAT (wb)	58	TC	114.2	114.2	129.4	108.9	108.9	123.4	102.9	102.9	116.6	96.3	96.3	109.1
				SHC	98.9	114.2	129.4	94.3	108.9	123.4	89.1	102.9	116.6	83.4	96.3	109.1
62			TC	117.2	117.2	127.9	111.0	111.0	124.7	104.0	104.0	119.5	96.5	96.5	113.7	
			SHC	91.1	109.5	127.9	88.1	106.4	124.7	83.9	101.7	119.5	79.3	96.5	113.7	
67			TC	127.8	127.8	127.8	121.7	121.7	121.7	114.5	114.5	114.5	106.6	106.6	106.6	
			SHC	73.8	92.3	110.8	71.3	89.8	108.3	68.4	87.0	105.5	65.2	83.8	102.3	
72		TC	139.4	139.4	139.4	133.0	133.0	133.0	125.8	125.8	125.8	117.9	117.9	117.9		
		SHC	56.0	74.6	93.1	53.7	72.2	90.8	51.0	69.6	88.2	48.1	66.7	85.4		
76		TC	—	148.8	148.8	—	142.2	142.2	—	134.9	134.9	—	126.8	126.8		
		SHC	—	60.2	79.5	—	58.0	77.1	—	55.4	74.5	—	52.7	71.6		
4000 Cfm		EAT (wb)	58	TC	119.0	119.0	134.9	114.0	114.0	129.2	108.0	108.0	122.4	101.1	101.1	114.6
				SHC	103.1	119.0	134.9	98.7	114.0	129.2	93.6	108.0	122.4	87.6	101.1	114.6
	62		TC	120.3	120.3	137.1	114.7	114.7	132.8	108.2	108.2	127.5	101.3	101.3	119.3	
			SHC	96.5	116.8	137.1	93.0	112.9	132.8	88.9	108.2	127.5	83.2	101.3	119.3	
	67		TC	130.5	130.5	130.5	124.1	124.1	124.1	116.8	116.8	116.8	108.7	108.7	111.1	
			SHC	77.7	98.6	119.5	75.2	96.2	117.2	72.3	93.3	114.4	69.1	90.1	111.1	
	72	TC	142.1	142.1	142.1	135.5	135.5	135.5	128.2	128.2	128.2	120.0	120.0	120.0		
		SHC	57.6	78.4	99.3	55.2	76.1	97.1	52.5	73.6	94.6	49.7	70.7	91.8		
	76	TC	—	151.4	151.4	—	144.7	144.7	—	137.1	137.1	—	—	—		
		SHC	—	62.3	83.8	—	60.0	81.4	—	57.5	78.8	—	—	—		
	4500 Cfm	EAT (wb)	58	TC	123.0	123.0	139.5	117.8	117.8	133.6	111.9	111.9	126.9	105.3	105.3	119.3
				SHC	106.6	123.0	139.5	102.1	117.8	133.6	97.0	111.9	126.9	91.2	105.3	119.3
62			TC	123.4	123.4	144.4	117.9	117.9	139.0	112.0	112.0	132.0	105.4	105.4	124.2	
			SHC	100.9	122.7	144.4	96.9	117.9	139.0	92.1	112.0	132.0	86.6	105.4	124.2	
67			TC	132.6	132.6	132.6	126.0	126.0	126.0	118.7	118.7	122.9	110.4	110.4	119.6	
			SHC	81.4	104.6	127.9	78.9	102.3	125.7	76.1	99.5	122.9	72.9	96.2	119.6	
72		TC	144.2	144.2	144.2	137.4	137.4	137.4	129.9	129.9	129.9	121.6	121.6	121.6		
		SHC	59.0	82.1	105.2	56.6	79.8	103.1	54.0	77.3	100.7	51.1	74.5	98.0		
76		TC	—	153.4	153.4	—	146.6	146.6	—	138.9	138.9	—	—	—		
		SHC	—	64.1	87.8	—	61.9	85.6	—	59.4	83.0	—	—	—		
5000 Cfm		EAT (wb)	58	TC	126.5	126.5	143.3	121.2	121.2	137.4	115.1	115.1	130.5	108.4	108.4	122.8
				SHC	109.6	126.5	143.3	105.0	121.2	137.4	99.8	115.1	130.5	93.9	108.4	122.8
	62		TC	126.5	126.5	149.1	121.3	121.3	142.9	115.2	115.2	135.8	108.5	108.5	127.8	
			SHC	104.0	126.5	149.1	99.7	121.3	142.9	94.7	115.2	135.8	89.1	108.5	127.8	
	67		TC	134.2	134.2	135.9	127.5	127.5	133.8	120.1	120.1	131.0	111.9	111.9	127.6	
			SHC	84.9	110.4	135.9	82.4	108.1	133.8	79.6	105.3	131.0	76.4	102.0	127.6	
	72	TC	145.8	145.8	145.8	139.0	139.0	139.0	131.3	131.3	131.3	122.9	122.9	122.9		
		SHC	60.3	85.6	110.8	57.9	83.4	108.9	55.3	81.0	106.6	52.5	78.2	104.0		
	76	TC	—	155.1	155.1	—	148.2	148.2	—	—	—	—	—	—		
		SHC	—	65.9	91.5	—	63.7	89.5	—	—	—	—	—	—		

**LEGEND**

- Edb** — Entering Dry-Bulb
- Ewb** — Entering Wet-Bulb
- kW** — Compressor Motor Power Input
- ldb** — Leaving Dry-Bulb
- lwb** — Leaving Wet-Bulb
- SHC** — Sensible Heat Capacity (1000 Btuh) Gross
- TC** — Total Capacity (1000 Btuh) Gross

NOTE: See Minimum-Maximum Airflow Ratings table on page 6. Do not operate outside these limits.

## COOLING CAPACITIES — 2-CIRCUIT/2-STAGE COOLING, 10 TONS

48TC 12 COOLING CAPACITIES, RTPF UNIT WITH HUMIDI-MIZER SYSTEM IN SUBCOOLING MODE										
TEMP (F) AIR ENT CONDENSER (Edb)		Air Entering Evaporator - CFM								
		3000/0.04			4000/0.06			5000/0.07		
		Air Entering Evaporator - Ewb (F)								
		72	67	62	72	67	62	72	67	62
75	TC	142.85	129.44	116.93	152.09	138.44	125.76	157.99	144.23	132.06
	SHC	58.38	74.88	91.58	67.96	89.45	111.02	76.63	102.94	127.93
	kW	7.19	6.97	6.79	6.92	7.12	7.35	7.45	7.22	7.02
85	TC	132.33	119.68	107.86	140.92	128.03	116.10	146.41	133.41	121.98
	SHC	48.44	65.56	82.83	57.37	79.50	101.68	65.65	92.58	118.12
	kW	7.98	7.77	7.58	7.72	7.92	8.14	8.25	8.01	7.82
95	TC	121.41	109.52	98.43	129.35	117.22	106.04	134.43	122.20	111.50
	SHC	38.19	55.92	73.78	46.47	69.22	92.01	54.34	81.92	107.96
	kW	8.87	8.66	8.48	8.61	8.80	9.03	9.14	8.90	8.71
105	TC	110.04	98.92	88.56	117.27	105.94	95.53	121.88	110.46	100.54
	SHC	27.59	45.94	64.39	35.16	58.57	81.98	42.56	70.82	97.40
	kW	9.86	9.66	9.48	9.61	9.79	10.02	10.12	9.89	9.70
115	TC	98.09	87.74	78.13	104.62	94.08	84.45	108.76	98.13	89.01
	SHC	16.52	35.47	54.53	23.37	47.44	71.46	30.32	59.25	86.31
	kW	10.95	10.76	10.60	10.72	10.89	11.10	11.19	10.98	10.81

48TC 12 COOLING CAPACITIES, RTPF UNIT WITH HUMIDI-MIZER SYSTEM IN HOT GAS REHEAT MODE										
Temp (F) Air Ent Condenser (Edb)		Air Entering Evaporator - Ewb (F)								
		75 Dry Bulb			75 Dry Bulb			75 Dry Bulb		
		62.5 Wet Bulb			64 Wet Bulb			65.3 Wet Bulb		
		(50% Relative)			(56% Relative)			(60% Relative)		
		Air Entering Evaporator - CFM								
		3000	4000	5000	3000	4000	5000	3000	4000	5000
80	TC	44.78	39.41	31.89	53.22	49.44	43.38	60.56	58.12	53.32
	SHC	-0.44	-0.57	-0.69	-0.37	-0.51	-0.61	-0.33	-0.46	-0.56
	kW	6.96	6.77	6.52	7.26	7.13	6.91	7.54	7.45	7.27
75	TC	45.84	40.46	32.86	54.28	50.51	44.45	61.61	59.19	54.40
	SHC	0.53	0.40	0.29	0.60	0.47	0.37	0.64	0.52	0.42
	kW	6.77	6.56	6.29	7.11	6.95	6.72	7.41	7.31	7.12
70	TC	46.91	41.48	33.50	55.36	51.59	45.50	62.69	60.28	55.49
	SHC	1.51	1.38	1.27	1.57	1.45	1.35	1.61	1.50	1.40
	kW	6.54	6.32	6.02	6.90	6.74	6.49	7.23	7.13	6.92
60	TC	48.88	43.42	35.76	57.29	53.56	47.48	64.56	62.16	57.42
	SHC	3.44	3.34	3.24	3.51	3.40	3.31	3.55	3.45	3.37
	kW	6.45	6.16	6.70	6.93	6.72	6.39	7.38	7.24	6.96
50	TC	50.83	45.28	37.67	59.22	55.52	49.43	66.05	64.03	59.34
	SHC	5.38	5.29	5.20	5.45	5.36	5.28	5.48	5.40	5.33
	kW	6.46	6.01	6.34	6.98	6.71	6.29	8.15	7.38	7.02
40	TC	52.82	47.29	39.50	61.14	57.48	51.39	68.23	65.88	61.25
	SHC	7.32	7.24	7.20	7.38	7.31	7.24	7.43	7.36	7.29
	kW	6.29	6.09	6.12	7.05	6.72	6.29	7.78	7.55	7.10

### LEGEND

**Edb** — Entering Dry-Bulb  
**Ewb** — Entering Wet-Bulb  
**kW** — Compressor Motor Power Input  
**ldb** — Leaving Dry-Bulb  
**lwb** — Leaving Wet-Bulb  
**SHC** — Sensible Heat Capacity (1000 Btu/h) Gross  
**TC** — Total Capacity (1000 Btu/h) Gross

### NOTES:

1. Direct interpolation is permissible. Do not extrapolate.
2. The following formulas may be used:

$$t_{ldb} = t_{edb} - \frac{\text{sensible capacity (Btu/h)}}{1.10 \times \text{cfm}}$$

$t_{lwb}$  = Wet-bulb temperature corresponding to enthalpy of air leaving evaporator coil ( $h_{lwb}$ )

$$h_{lwb} = h_{ewb} - \frac{\text{total capacity (Btu/h)}}{4.5 \times \text{cfm}}$$

Where:  $h_{ewb}$  = Enthalpy of air entering evaporator coil





**COOLING CAPACITIES — 1-CIRCUIT/2-STAGE COOLING, 10 TONS**

48TC-M12 (RTPF)			AMBIENT TEMPERATURE (F)													
			85			95			105			115				
			EAT (db)			EAT (db)			EAT (db)			EAT (db)				
			75	80	85	75	80	85	75	80	85	75	80	85		
3000 Cfm	EAT (wb)	58	TC	107.8	107.8	122.1	102.5	102.5	116.3	96.9	96.9	110.2	91.1	91.1	103.7	
			SHC	93.4	107.8	122.1	88.7	102.5	116.3	83.7	96.9	110.2	78.5	91.1	103.7	
		62	TC	114.4	114.4	114.4	107.9	107.9	110.8	100.8	100.8	106.6	93.8	93.8	102.7	
			SHC	83.7	99.0	114.4	80.0	95.4	110.8	76.0	91.3	106.6	72.2	87.5	102.7	
		67	TC	125.7	125.7	125.7	118.8	118.8	118.8	111.3	111.3	111.3	103.6	103.6	103.6	
			SHC	68.7	83.9	99.1	65.1	80.4	95.6	61.4	76.6	91.9	57.5	72.8	88.1	
	72	TC	138.0	138.0	138.0	130.8	130.8	130.8	122.8	122.8	122.8	114.4	114.4	114.4		
		SHC	53.8	68.6	83.4	50.3	65.2	80.1	46.6	61.5	76.5	42.7	57.7	72.8		
	76	TC	—	148.9	148.9	—	141.1	141.1	—	132.5	132.5	—	123.3	123.3		
		SHC	—	55.8	72.3	—	52.7	69.2	—	49.2	62.7	—	45.5	59.7		
	3500 Cfm	EAT (wb)	58	TC	114.0	114.0	129.1	108.4	108.4	122.9	102.4	102.4	116.3	96.2	96.2	109.4
				SHC	98.9	114.0	129.1	93.9	108.4	122.9	88.6	102.4	116.3	83.0	96.2	109.4
62			TC	118.1	118.1	125.6	111.3	111.3	121.6	104.1	104.1	117.5	96.9	96.9	112.5	
			SHC	90.4	108.0	125.6	86.5	104.1	121.6	82.5	100.0	117.5	78.0	95.3	112.5	
67			TC	129.4	129.4	129.4	122.2	122.2	122.2	114.4	114.4	114.4	106.4	106.4	106.4	
			SHC	73.1	90.7	108.2	69.5	87.1	104.6	65.7	83.3	100.9	61.8	79.4	97.0	
72		TC	141.9	141.9	141.9	134.3	134.3	134.3	126.0	126.0	126.0	117.2	117.2	117.2		
		SHC	55.8	73.1	90.3	52.3	69.6	86.8	48.5	65.8	83.1	44.6	61.9	79.3		
76		TC	—	152.2	152.2	—	144.5	144.5	—	135.4	135.4	—	126.0	126.0		
		SHC	—	58.6	74.0	—	55.3	71.4	—	51.6	68.1	—	47.8	64.6		
4000 Cfm		EAT (wb)	58	TC	119.2	119.2	134.9	113.3	113.3	128.4	107.0	107.0	121.5	100.4	100.4	114.1
				SHC	103.5	119.2	134.9	98.2	113.3	128.4	92.6	107.0	121.5	86.6	100.4	114.1
	62		TC	121.0	121.0	135.9	114.3	114.3	131.4	107.5	107.5	125.2	101.1	101.1	117.1	
			SHC	96.5	116.2	135.9	92.4	111.9	131.4	87.3	106.2	125.2	81.5	99.3	117.1	
	67		TC	132.3	132.3	132.3	124.9	124.9	124.9	117.0	117.0	117.0	108.5	108.5	108.5	
			SHC	77.3	97.2	117.0	73.6	93.5	113.3	69.8	89.7	109.5	65.8	85.6	105.5	
	72	TC	144.8	144.8	144.8	137.0	137.0	137.0	128.4	128.4	128.4	119.3	119.3	119.3		
		SHC	57.6	77.2	96.7	54.1	73.6	93.2	50.2	69.8	89.4	46.2	65.9	85.5		
	76	TC	—	155.4	155.4	—	146.8	146.8	—	137.7	137.7	—	127.9	127.9		
		SHC	—	61.0	79.4	—	57.5	76.2	—	53.8	72.7	—	49.8	69.0		
	4500 Cfm	EAT (wb)	58	TC	123.4	123.4	139.6	117.4	117.4	132.9	110.8	110.8	125.6	103.8	103.8	117.9
				SHC	107.2	123.4	139.6	101.8	117.4	132.9	95.9	110.8	125.6	89.7	103.8	117.9
62			TC	124.0	124.0	143.3	118.1	118.1	136.3	111.2	111.2	129.4	103.9	103.9	122.7	
			SHC	101.1	122.2	143.3	95.9	116.1	136.3	90.5	110.0	129.4	85.1	103.9	122.7	
67			TC	134.6	134.6	134.6	127.0	127.0	127.0	118.9	118.9	118.9	110.2	110.2	113.8	
			SHC	81.3	103.3	125.4	77.5	99.6	121.6	73.7	95.7	117.8	69.6	91.7	113.8	
72		TC	147.0	147.0	147.0	139.1	139.1	139.1	130.3	130.3	130.3	121.0	121.0	121.0		
		SHC	59.3	81.1	102.8	55.7	77.5	99.3	51.9	73.7	95.5	47.8	69.6	91.4		
76		TC	—	157.5	157.5	—	148.9	148.9	—	139.5	139.5	—	129.4	129.4		
		SHC	—	63.1	84.0	—	59.6	80.7	—	55.7	77.0	—	51.8	73.1		
5000 Cfm		EAT (wb)	58	TC	127.1	127.1	143.8	120.8	120.8	136.8	113.9	113.9	129.2	106.8	106.8	121.3
				SHC	110.5	127.1	143.8	104.8	120.8	136.8	98.7	113.9	129.2	92.4	106.8	121.3
	62		TC	127.7	127.7	148.1	121.2	121.2	141.5	114.0	114.0	134.3	106.9	106.9	126.2	
			SHC	104.4	126.3	148.1	99.3	120.4	141.5	93.7	114.0	134.3	87.6	106.9	126.2	
	67		TC	136.5	136.5	136.5	128.7	128.7	129.7	120.4	120.4	125.7	111.5	111.5	121.4	
			SHC	85.1	109.3	133.5	81.3	105.5	129.7	77.3	101.5	125.7	73.1	97.3	121.4	
	72	TC	149.0	149.0	149.0	140.9	140.9	140.9	131.8	131.8	131.8	122.4	122.4	122.4		
		SHC	60.9	84.9	108.8	57.3	81.3	105.2	53.4	77.3	101.3	49.4	73.3	97.2		
	76	TC	—	159.2	159.2	—	150.5	150.5	—	140.8	140.8	—	130.6	130.6		
		SHC	—	65.1	88.3	—	61.5	84.8	—	57.6	81.0	—	53.6	76.9		

**LEGEND**

- Do not operate
- Cfm — Cubic feet per minute (supply air)
- EAT (db) — Entering Air Temperature (dry bulb)
- EAT (wb) — Entering Air Temperature (wet bulb)
- SHC — Sensible Heat Capacity (1000 Btuh) Gross
- TC — Total Capacity (1000 Btuh) Gross

NOTE: See Minimum-Maximum Airflow Ratings table on page 6. Do not operate outside these limits.

## COOLING CAPACITIES — 2-CIRCUIT/2-STAGE COOLING, 12.5 TONS

48TC-D14 (RTPF and Novation®)			AMBIENT TEMPERATURE (F)													
			85			95			105			115				
			EAT (db)			EAT (db)			EAT (db)			EAT (db)				
			75	80	85	75	80	85	75	80	85	75	80	85		
3600 Cfm	EAT (wb)	58	TC	127.6	127.6	142.9	121.7	121.7	137.6	115.0	115.0	130.0	108.3	108.3	122.6	
			SHC	110.3	126.6	142.9	105.8	121.7	137.6	99.9	115.0	130.0	94.1	108.3	122.6	
		62	TC	136.1	136.1	136.1	131.1	131.1	131.1	123.8	123.8	124.5	114.9	114.9	120.3	
			SHC	96.6	112.8	129.0	94.7	111.2	127.7	91.4	108.0	124.5	87.3	103.8	120.3	
		67	TC	146.2	146.2	146.2	142.0	142.0	142.0	136.2	136.2	136.2	128.8	128.8	128.8	
			SHC	78.5	94.4	110.3	76.9	93.1	109.2	74.7	91.0	107.3	71.7	88.1	104.6	
	72	TC	155.9	155.9	155.9	152.4	152.4	152.4	147.2	147.2	147.2	140.1	140.1	140.1		
		SHC	60.1	76.6	93.2	58.7	75.2	91.7	56.8	73.3	89.7	54.2	70.6	87.0		
	76	TC	—	163.0	163.0	—	160.0	160.0	—	155.1	155.1	—	148.2	148.2		
		SHC	—	62.0	81.8	—	61.1	80.9	—	59.5	79.3	—	57.0	76.3		
	4200 Cfm	EAT (wb)	58	TC	132.2	132.2	149.5	128.2	128.2	144.9	121.9	121.9	137.8	115.0	115.0	130.1
				SHC	115.0	132.2	149.5	111.5	128.2	144.9	106.0	121.9	137.8	99.9	115.0	130.1
62			TC	139.6	139.6	139.6	134.7	134.7	138.0	128.0	128.0	135.6	119.1	119.1	131.2	
			SHC	102.5	120.8	139.0	100.8	119.4	138.0	98.1	116.8	135.6	93.9	112.6	131.2	
67			TC	149.5	149.5	149.5	145.4	145.4	145.4	139.6	139.6	139.6	132.1	132.1	132.1	
			SHC	81.8	99.6	117.4	80.6	98.7	116.8	78.5	96.9	115.2	75.7	94.3	112.8	
72		TC	159.0	159.0	159.0	155.5	155.5	155.5	150.3	150.3	150.3	143.1	143.1	143.1		
		SHC	61.4	79.6	97.8	60.2	78.5	96.8	58.3	76.7	95.0	55.8	74.2	92.5		
76		TC	—	165.7	165.7	—	162.8	162.8	—	157.8	157.8	—	150.8	150.8		
		SHC	—	64.6	87.7	—	63.5	86.3	—	61.5	83.3	—	58.9	79.9		
4800 Cfm		EAT (wb)	58	TC	136.7	136.7	154.5	133.0	133.0	150.3	127.7	127.7	144.3	120.6	120.6	136.4
				SHC	118.9	136.7	154.5	115.7	133.0	150.3	111.0	127.7	144.3	104.9	120.6	136.4
	62		TC	142.2	142.2	147.8	137.4	137.4	147.1	131.0	131.0	144.7	122.8	122.8	140.3	
			SHC	107.7	127.8	147.8	106.2	126.7	147.1	103.6	124.2	144.7	99.3	119.8	140.3	
	67		TC	152.1	152.1	152.1	148.0	148.0	148.0	142.2	142.2	142.2	134.6	134.6	134.6	
			SHC	84.8	104.3	123.7	83.8	103.8	123.7	82.0	102.3	122.6	79.4	99.9	120.4	
	72	TC	161.3	161.3	161.3	157.8	157.8	157.8	152.5	152.5	152.5	145.4	145.4	145.4		
		SHC	62.6	82.2	101.9	61.4	81.4	101.3	59.7	79.7	99.8	57.2	77.3	97.5		
	76	TC	—	167.7	167.7	—	164.9	164.9	—	159.9	159.9	—	152.8	152.8		
		SHC	—	66.4	91.4	—	65.0	89.2	—	63.1	86.4	—	60.5	83.1		
	5400 Cfm	EAT (wb)	58	TC	140.5	140.5	158.8	136.9	136.9	154.7	131.8	131.8	149.0	125.2	125.2	141.6
				SHC	122.2	140.5	158.8	119.0	136.9	154.7	114.7	131.8	149.0	108.9	125.2	141.6
62			TC	144.3	144.3	155.7	139.6	139.6	155.0	133.5	133.5	152.4	125.8	125.8	147.8	
			SHC	112.2	133.9	155.7	110.9	132.9	155.0	108.1	130.2	152.4	103.9	125.8	147.8	
67			TC	154.2	154.2	154.2	150.0	150.0	150.0	144.2	144.2	144.2	136.7	136.7	136.7	
			SHC	87.6	108.6	129.6	86.8	108.5	130.1	85.2	107.3	129.4	82.8	105.1	127.4	
72		TC	163.1	163.1	163.1	159.7	159.7	159.7	154.3	154.3	154.3	147.1	147.1	147.1		
		SHC	63.6	84.6	105.6	62.5	83.9	105.4	60.8	82.5	104.2	58.4	80.2	102.0		
76		TC	—	169.3	169.3	—	166.5	166.5	—	161.5	161.5	—	154.2	154.2		
		SHC	—	67.6	93.7	—	66.4	91.7	—	64.5	89.2	—	61.9	86.1		
6000 Cfm		EAT (wb)	58	TC	143.6	143.6	162.3	140.1	140.1	158.3	135.1	135.1	152.7	128.7	128.7	145.5
				SHC	124.9	143.6	162.3	121.8	140.1	158.3	117.5	135.1	152.7	111.9	128.7	145.5
	62		TC	146.1	146.1	162.4	141.7	141.7	161.5	135.6	135.6	159.2	128.8	128.8	151.2	
			SHC	116.1	139.3	162.4	114.7	138.1	161.5	112.1	135.6	159.2	106.4	128.8	151.2	
	67		TC	155.8	155.8	155.8	151.6	151.6	151.6	145.9	145.9	145.9	138.3	138.3	138.3	
			SHC	90.1	112.6	135.0	89.6	112.8	136.0	88.3	112.0	135.8	85.9	110.0	134.1	
	72	TC	164.5	164.5	164.5	161.2	161.2	161.2	155.8	155.8	155.8	148.5	148.5	148.5		
		SHC	64.5	86.7	108.9	63.5	86.3	109.1	61.9	85.1	108.2	59.6	82.9	106.3		
	76	TC	—	170.6	170.6	—	167.8	167.8	—	162.8	162.8	—	155.5	155.5		
		SHC	—	68.7	95.8	—	67.5	94.1	—	65.7	91.8	—	63.3	88.8		

**LEGEND**

- Do not operate
- Cfm — Cubic feet per minute (supply air)
- EAT (db) — Entering Air Temperature (dry bulb)
- EAT (wb) — Entering Air Temperature (wet bulb)
- SHC — Sensible Heat Capacity (1000 Btuh) Gross
- TC — Total Capacity (1000 Btuh) Gross

NOTE: See Minimum-Maximum Airflow - Natural Gas and Propane Ratings on page 6. Do not operate outside these limits.



## COOLING CAPACITIES — 2-CIRCUIT/2-STAGE COOLING, 12.5 TONS

48TC 14 COOLING CAPACITIES, RTPF UNIT WITH HUMIDI-MIZER SYSTEM IN SUBCOOLING MODE										
TEMP (F) AIR ENT CONDENSER (Edb)		Air Entering Evaporator - CFM								
		3750/0.02			5000/0.06			6250/0.05		
		Air Entering Evaporator - Ewb (F)								
		72	67	62	72	67	62	72	67	62
75	TC	183.66	166.86	151.43	194.90	177.83	162.05	201.97	184.84	170.53
	SHC	79.39	100.52	121.91	91.70	119.42	147.05	102.94	137.00	166.71
	kW	9.82	9.63	9.46	9.58	9.76	9.96	10.04	9.84	9.67
85	TC	172.71	156.78	142.09	183.32	167.13	152.17	189.98	173.73	160.25
	SHC	69.03	90.92	112.95	80.69	109.17	137.51	91.49	126.33	156.65
	kW	10.82	10.63	10.45	10.57	10.76	10.96	11.04	10.84	10.67
95	TC	161.37	146.24	132.38	171.36	156.04	141.86	177.62	162.22	149.50
	SHC	58.44	81.04	103.77	69.42	98.67	127.71	79.83	115.45	146.15
	kW	11.92	11.73	11.56	11.68	11.86	12.05	12.14	11.93	11.77
105	TC	149.57	135.32	122.21	158.89	144.45	131.10	164.74	150.27	138.35
	SHC	47.57	70.92	94.32	57.85	87.91	117.61	67.79	104.26	135.30
	kW	13.12	12.94	12.77	12.89	13.06	13.24	13.32	13.13	12.97
115	TC	137.22	123.88	111.55	145.85	132.33	119.84	151.27	137.71	126.67
	SHC	36.31	60.47	84.57	45.87	76.77	107.19	55.34	92.66	123.98
	kW	14.41	14.25	14.10	14.20	14.35	14.53	14.59	14.42	14.28

48TC 14 COOLING CAPACITIES, RTPF UNIT WITH HUMIDI-MIZER SYSTEM IN HOT GAS REHEAT MODE											
TEMP (F) AIR ENTERING CONDENSER (Edb)		Air Entering Evaporator - Ewb (F)									
		75 Dry Bulb			75 Dry Bulb			75 Dry Bulb			
		62.5 Wet Bulb			64 Wet Bulb			65.3 Wet Bulb			
		(50% Relative)			(56% Relative)			(60% Relative)			
		Air Entering Evaporator - CFM									
3750	5000	6250	3750	5000	6250	3750	5000	6250	3750	5000	6250
80	TC	52.42	45.88	36.99	62.64	58.07	51.07	71.56	68.64	63.23	
	SHC	-0.39	-0.54	-0.67	-0.31	-0.46	-0.58	-0.26	-0.40	-0.52	
	kW	9.65	9.39	9.07	9.97	9.77	9.50	10.25	10.11	9.89	
75	TC	53.45	46.63	36.10	63.77	59.11	51.87	72.76	69.80	64.31	
	SHC	0.59	0.44	0.30	0.67	0.52	0.40	0.72	0.58	0.47	
	kW	9.09	8.83	8.49	9.39	9.20	8.94	9.67	9.53	9.32	
70	TC	54.33	46.91	37.58	64.77	60.01	52.30	73.80	70.80	65.24	
	SHC	1.56	1.41	1.29	1.64	1.50	1.38	1.70	1.56	1.45	
	kW	8.81	8.53	8.62	9.15	8.94	8.65	9.46	9.31	9.08	
60	TC	55.47	49.48	40.48	66.62	62.07	54.88	75.68	72.76	67.28	
	SHC	3.50	3.38	3.27	3.59	3.47	3.36	3.65	3.52	3.42	
	kW	8.36	8.84	8.98	9.88	9.56	9.10	9.83	9.64	9.31	
50	TC	58.33	51.72	42.81	68.72	63.93	55.84	77.74	74.77	69.24	
	SHC	5.47	5.35	5.24	5.54	5.43	5.32	5.60	5.49	5.39	
	kW	8.98	9.25	9.43	9.33	8.97	8.73	9.55	9.33	9.70	
40	TC	60.33	53.69	46.89	70.67	65.93	49.83	79.46	76.62	71.24	
	SHC	7.42	7.31	7.22	7.49	7.39	7.23	7.55	7.45	7.37	
	kW	9.16	9.88	9.06	9.50	9.05	9.47	10.31	10.00	9.48	

**LEGEND**

- Edb** — Entering Dry-Bulb
- Ewb** — Entering Wet-Bulb
- kW** — Compressor Motor Power Input
- ldb** — Leaving Dry-Bulb
- lwb** — Leaving Wet-Bulb
- SHC** — Sensible Heat Capacity (1000 Btuh) Gross
- TC** — Total Capacity (1000 Btuh) Gross

**NOTES:**

1. Direct interpolation is permissible. Do not extrapolate.
2. The following formulas may be used:

$$t_{ldb} = t_{edb} - \frac{\text{sensible capacity (Btuh)}}{1.10 \times \text{cfm}}$$

$t_{lwb}$  = Wet-bulb temperature corresponding to enthalpy of air leaving evaporator coil ( $h_{lwb}$ )

$$h_{lwb} = h_{ewb} - \frac{\text{total capacity (Btuh)}}{4.5 \times \text{cfm}}$$

Where:  $h_{ewb}$  = Enthalpy of air entering evaporator coil

## COOLING CAPACITIES — 2-CIRCUIT/2-STAGE COOLING, 15 TONS

48TC-D16 (RTPF)			AMBIENT TEMPERATURE (F)													
			85			95			105			115				
			EAT (db)			EAT (db)			EAT (db)			EAT (db)				
			75	80	85	75	80	85	75	80	85	75	80	85		
4500 Cfm	EAT (wb)	58	TC	156.6	156.6	175.2	149.4	149.4	169.1	141.6	141.6	160.2	133.3	133.3	150.9	
			SHC	134.7	154.9	175.2	129.8	149.4	169.1	123.0	141.6	160.2	115.7	133.3	150.9	
		62	TC	166.7	166.7	166.9	158.0	158.0	162.6	147.6	147.6	157.2	136.8	136.8	150.3	
			SHC	122.8	144.9	166.9	118.6	140.6	162.6	113.5	135.3	157.2	107.4	128.8	150.3	
		67	TC	184.1	184.1	184.1	175.6	175.6	175.6	165.6	165.6	165.6	154.5	154.5	154.5	
			SHC	101.6	123.7	145.7	98.1	120.2	142.3	94.0	116.1	138.2	89.4	111.5	133.6	
	72	TC	200.3	200.3	200.3	192.0	192.0	192.0	182.9	182.9	182.9	172.2	172.2	172.2		
		SHC	78.7	101.1	123.5	75.5	97.9	120.2	72.1	94.4	116.7	68.2	90.5	112.7		
	76	TC	—	211.4	211.4	—	203.1	203.1	—	193.8	193.8	—	183.9	183.9		
		SHC	—	82.2	107.0	—	79.3	103.8	—	76.0	100.2	—	72.6	96.5		
	5250 Cfm	EAT (wb)	58	TC	165.2	165.2	186.9	158.2	158.2	179.0	150.0	150.0	169.7	141.3	141.3	160.0
				SHC	143.5	165.2	186.9	137.4	158.2	179.0	130.2	150.0	169.7	122.7	141.3	160.0
62			TC	172.3	172.3	181.7	163.4	163.4	176.9	153.1	153.1	169.3	143.4	143.4	161.4	
			SHC	131.6	156.6	181.7	127.1	152.0	176.9	120.5	144.9	169.3	114.1	137.8	161.4	
67			TC	189.5	189.5	189.5	180.9	180.9	180.9	170.7	170.7	170.7	159.1	159.1	159.1	
			SHC	107.2	132.4	157.5	103.8	129.0	154.1	99.9	125.1	150.4	95.3	120.6	145.8	
72		TC	205.0	205.0	205.0	196.5	196.5	196.5	187.1	187.1	187.1	176.4	176.4	176.4		
		SHC	80.9	106.1	131.3	77.7	102.9	128.1	74.4	99.5	124.7	70.6	95.8	121.0		
76		TC	—	215.4	215.4	—	206.8	206.8	—	197.1	197.1	—	186.9	186.9		
		SHC	—	85.0	113.0	—	82.0	109.8	—	78.8	106.4	—	75.4	102.8		
6000 Cfm		EAT (wb)	58	TC	172.7	172.7	195.4	165.5	165.5	187.3	157.1	157.1	177.8	148.1	148.1	167.7
				SHC	150.0	172.7	195.4	143.8	165.5	187.3	136.4	157.1	177.8	128.6	148.1	167.7
	62		TC	176.6	176.6	195.7	168.1	168.1	187.6	158.9	158.9	180.2	148.9	148.9	172.1	
			SHC	139.6	167.7	195.7	133.2	160.4	187.6	127.1	153.7	180.2	120.7	146.4	172.1	
	67		TC	193.6	193.6	193.6	184.8	184.8	184.8	174.7	174.7	174.7	162.7	162.7	162.7	
			SHC	112.3	140.3	168.3	108.9	137.0	165.2	105.2	133.5	161.7	100.7	129.0	157.3	
	72	TC	208.4	208.4	208.4	199.6	199.6	199.6	190.2	190.2	190.2	179.5	179.5	179.5		
		SHC	82.7	110.5	138.3	79.6	107.3	135.1	76.2	104.0	131.8	72.6	100.6	128.5		
	76	TC	—	218.2	218.2	—	209.5	209.5	—	199.5	199.5	—	189.0	189.0		
		SHC	—	87.5	118.6	—	84.5	115.2	—	81.1	111.3	—	77.5	107.3		
	6750 Cfm	EAT (wb)	58	TC	178.8	178.8	202.4	171.6	171.6	194.2	163.1	163.1	184.6	153.8	153.8	174.1
				SHC	155.3	178.8	202.4	149.0	171.6	194.2	141.6	163.1	184.6	133.5	153.8	174.1
62			TC	181.0	181.0	203.6	173.0	173.0	197.5	163.8	163.8	190.1	153.9	153.9	181.1	
			SHC	144.1	173.9	203.6	139.1	168.3	197.5	133.3	161.7	190.1	126.7	153.9	181.1	
67			TC	196.8	196.8	196.8	187.9	187.9	187.9	177.7	177.7	177.7	165.5	165.5	167.9	
			SHC	117.0	147.7	178.4	113.7	144.5	175.4	110.1	141.1	172.2	105.6	136.8	167.9	
72		TC	211.0	211.0	211.0	202.2	202.2	202.2	192.5	192.5	192.5	181.8	181.8	181.8		
		SHC	84.3	114.5	144.7	81.2	111.5	141.7	77.9	108.1	138.4	74.4	104.9	135.4		
76		TC	—	220.2	220.2	—	211.5	211.5	—	201.3	201.3	—	190.6	190.6		
		SHC	—	89.5	122.8	—	86.4	119.4	—	83.0	115.4	—	79.4	111.5		
7500 Cfm		EAT (wb)	58	TC	183.9	183.9	208.2	176.6	176.6	199.8	168.2	168.2	190.3	158.6	158.6	179.5
				SHC	159.7	183.9	208.2	153.3	176.6	199.8	146.0	168.2	190.3	137.7	158.6	179.5
	62		TC	185.1	185.1	212.5	177.1	177.1	206.2	168.3	168.3	197.9	158.7	158.7	186.7	
			SHC	149.5	181.0	212.5	144.5	175.4	206.2	138.7	168.3	197.9	130.8	158.7	186.7	
	67		TC	199.3	199.3	199.3	190.3	190.3	190.3	180.0	180.0	181.7	167.8	167.8	177.8	
			SHC	121.3	154.6	187.9	118.1	151.6	185.1	114.4	148.1	181.7	110.1	144.0	177.8	
	72	TC	213.0	213.0	213.0	204.1	204.1	204.1	194.2	194.2	194.2	183.5	183.5	183.5		
		SHC	85.8	118.2	150.5	82.7	115.2	147.7	79.4	111.9	144.4	76.0	108.8	141.6		
	76	TC	—	221.9	221.9	—	213.0	213.0	—	202.7	202.7	—	191.8	191.8		
		SHC	—	91.2	126.5	—	88.2	123.1	—	84.7	119.2	—	81.2	115.3		

**LEGEND**

- Do not operate
- Cfm** — Cubic feet per minute (supply air)
- EAT (db)** — Entering Air Temperature (dry bulb)
- EAT (wb)** — Entering Air Temperature (wet bulb)
- SHC** — Sensible Heat Capacity (1000 Btuh) Gross
- TC** — Total Capacity (1000 Btuh) Gross

NOTE: See Minimum-Maximum Airflow - Natural Gas and Propane Ratings on page 6. Do not operate outside these limits.



## COOLING CAPACITIES — 2-CIRCUIT/2-STAGE COOLING, 15 TONS

### 48TC\*E16 COOLING CAPACITIES, UNIT WITH HUMIDI-MIZER SYSTEM IN SUBCOOLING MODE

Temp (F) Air Entering Condenser (Edb)		Air Entering Evaporator - CFM								
		4500/0.02			6000/0.06			7500/0.05		
		Air Entering Evaporator - Ewb (F)								
		72	67	62	72	67	62	72	67	62
75	TC	204.40	186.30	168.20	218.40	199.60	180.90	229.60	210.40	191.20
	SHC	98.90	118.10	137.20	114.80	133.70	152.60	127.60	146.20	164.90
	kW	11.57	11.22	10.77	11.78	11.45	11.00	12.06	11.64	11.35
85	TC	189.20	171.70	154.10	203.00	184.80	166.70	214.10	195.50	176.90
	SHC	79.50	103.40	127.30	96.50	120.20	144.00	110.20	133.70	157.30
	kW	12.59	12.24	11.81	12.81	12.50	12.03	13.05	12.66	12.47
95	TC	174.00	157.00	140.00	187.60	170.10	152.50	198.60	180.60	162.70
	SHC	60.00	88.70	117.50	78.20	106.80	135.30	92.90	121.30	149.70
	kW	13.68	13.35	12.86	13.91	13.57	13.05	14.15	13.75	13.47
105	TC	158.80	142.30	125.80	172.20	155.30	138.30	183.10	165.70	148.40
	SHC	40.50	74.10	107.70	59.90	93.30	126.70	75.50	108.80	142.00
	kW	14.67	14.41	13.88	14.90	14.55	14.10	15.15	14.73	14.53
115	TC	143.60	127.60	111.70	156.80	140.50	124.10	167.60	150.90	134.20
	SHC	21.00	59.40	97.80	41.60	79.90	118.10	58.10	96.30	134.20
	kW	15.77	15.38	14.88	15.88	15.65	15.10	16.12	15.84	15.54

### 48TC\*E 16 COOLING CAPACITIES, UNIT WITH HUMIDI-MIZER SYSTEM IN HOT GAS REHEAT MODE

Temp (F) Air Ent Condenser (Edb)		Air Entering Evaporator - Ewb (F)								
		75 Dry Bulb			75 Dry Bulb			75 Dry Bulb		
		62.5 Wet Bulb			64 Wet Bulb			65.3 Wet Bulb		
		(50% Relative)			(56% Relative)			(60% Relative)		
		Air Entering Evaporator - CFM								
		4500	6000	7500	4500	6000	7500	4500	6000	7500
80	TC	83.75	84.85	88.95	86.65	91.90	92.90	87.90	91.75	96.30
	SHC	37.50	42.80	55.10	30.90	40.40	44.50	24.80	29.30	34.10
	kW	10.50	11.49	11.60	10.56	10.65	11.70	11.60	11.72	11.77
75	TC	85.00	86.00	90.50	88.05	93.60	94.65	89.20	93.45	97.85
	SHC	40.00	45.00	57.30	33.20	42.30	46.90	26.90	31.50	36.30
	kW	10.16	11.15	11.25	10.21	10.31	11.33	11.26	11.35	11.42
70	TC	86.15	87.35	91.50	89.20	94.30	96.10	90.40	94.10	98.95
	SHC	42.10	47.50	59.80	35.50	45.30	49.50	29.50	33.90	38.70
	kW	9.84	10.83	10.94	10.02	10.13	11.03	10.95	11.05	11.12
60	TC	88.90	90.10	94.25	92.00	97.10	98.20	93.20	96.90	101.75
	SHC	46.80	52.30	64.60	40.20	50.10	54.10	34.10	38.60	43.40
	kW	9.37	10.36	10.44	9.42	9.52	10.55	10.45	10.57	10.64
50	TC	91.70	92.80	97.00	94.80	99.90	101.00	96.10	99.70	104.20
	SHC	51.50	57.10	69.40	44.80	54.80	58.90	38.70	43.20	49.00
	kW	9.12	10.09	10.16	9.17	9.28	10.26	10.17	10.26	10.32
40	TC	94.45	95.60	99.80	97.45	102.55	103.70	98.65	102.35	107.00
	SHC	56.30	61.40	73.70	49.70	59.20	63.30	43.60	48.10	52.90
	kW	9.05	10.02	10.10	9.10	9.21	10.18	10.11	10.20	10.26

**LEGEND**

- Edb** — Entering Dry-Bulb
- Ewb** — Entering Wet-Bulb
- kW** — Compressor Motor Power Input
- ldb** — Leaving Dry-Bulb
- lwb** — Leaving Wet-Bulb
- SHC** — Sensible Heat Capacity (1000 Btuh) Gross
- TC** — Total Capacity (1000 Btuh) Gross

**NOTES:**

1. Direct interpolation is permissible. Do not extrapolate.
2. The following formulas may be used:

$$t_{ldb} = t_{edb} - \frac{\text{sensible capacity (Btuh)}}{1.10 \times \text{cfm}}$$

$t_{lwb}$  = Wet-bulb temperature corresponding to enthalpy of air leaving evaporator coil ( $h_{lwb}$ )

$$h_{lwb} = h_{ewb} - \frac{\text{total capacity (Btuh)}}{4.5 \times \text{cfm}}$$

Where:  $h_{ewb}$  = Enthalpy of air entering evaporator coil

# Performance data (cont)



## STATIC PRESSURE ADDERS (in. wg) — FACTORY OPTIONS AND/OR ACCESSORIES

### Humidi-MiZer® Coil

6 TONS									
CFM	1000	1250	1500	1750	2000	2250	2500	2750	3000
6 Tons 1-Circuit/ 1-Stage Cooling	—	—	—	0.112	0.125	0.161	0.19	0.22	0.25

7.5 - 12.5 TONS																
CFM	2250	2500	2750	3000	3250	3500	3750	4000	4250	4500	4750	5000	5250	5500	5750	6000
7.5 Tons 2-Circuit/ 2-Stage Cooling	0.12	0.14	0.16	0.19	0.21	0.23	0.26	—	—	—	—	—	—	—	—	—
8.5 Tons 2-Circuit/ 2-Stage Cooling	—	0.11	0.12	0.13	0.15	0.17	0.18	0.20	0.22	—	—	—	—	—	—	—
10 Tons 2-Circuit/ 2-Stage Cooling	—	—	—	0.13	0.15	0.17	0.18	0.20	0.22	0.24	0.26	0.28	—	—	—	—
12.5 Tons 2-Circuit/ 2-Stage Cooling	—	—	—	—	—	0.17	0.18	0.20	0.22	0.24	0.26	0.28	0.31	0.33	0.36	0.39

15 TONS														
CFM	4000	4250	4500	4750	5000	5250	5500	5750	6000	6250	6500	6750	7000	7250
15 Tons 2-Circuit/ 2-Stage Cooling	0.06	0.07	0.07	0.08	0.08	0.09	0.10	0.10	0.11	0.12	0.12	0.13	0.14	0.15

### ECONOMIZER, BAROMETRIC RELIEF AND PE PERFORMANCE — VERTICAL APPLICATION

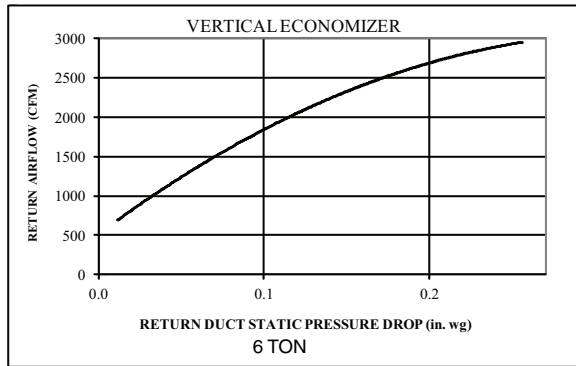

**Return air pressure drop — vertical 6 tons**

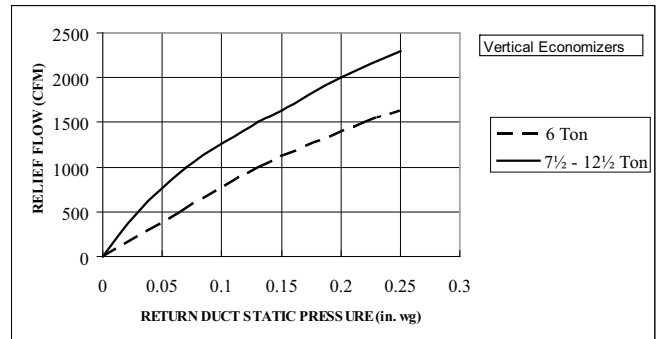

**Barometric relief flow capacity — 6 to 12½ tons**

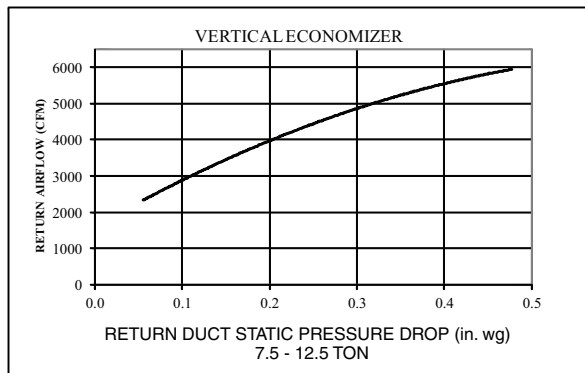

**Return air pressure drop — 7½ to 12½ tons**

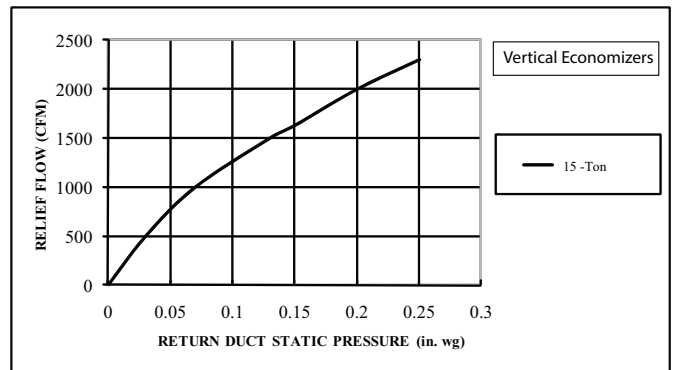

**Barometric relief flow capacity - vertical 15 tons**

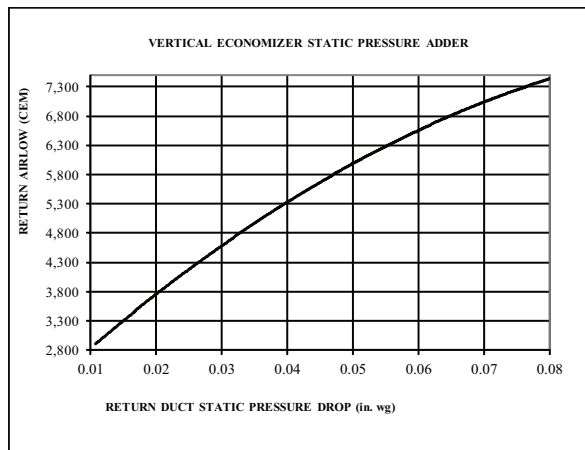

**Return air pressure drop - vertical 15 tons**

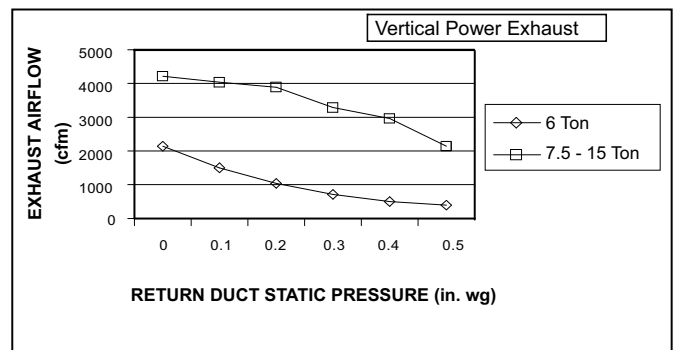

**Vertical power exhaust performance**

All data for both low leak and ultra low leak models, where available.



## ECONOMIZER, BAROMETRIC RELIEF AND PE PERFORMANCE — HORIZONTAL APPLICATION

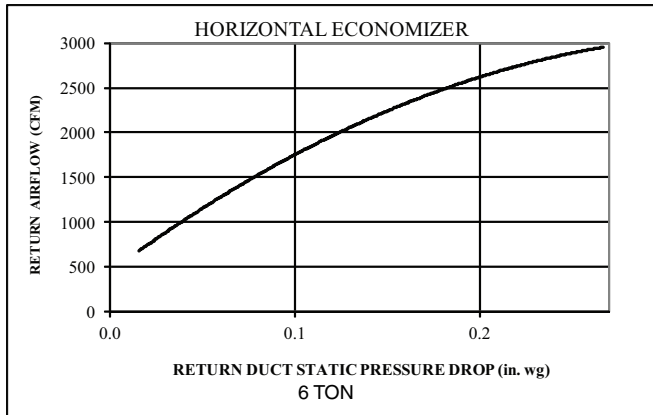

Return air pressure drop — 6 tons

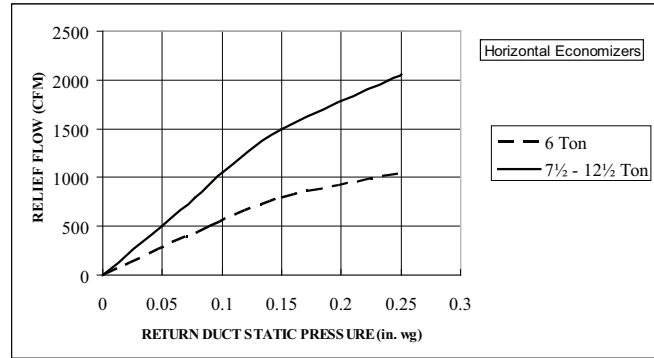

Barometric relief flow capacity — 6 to 12<sup>1</sup>/<sub>2</sub> tons

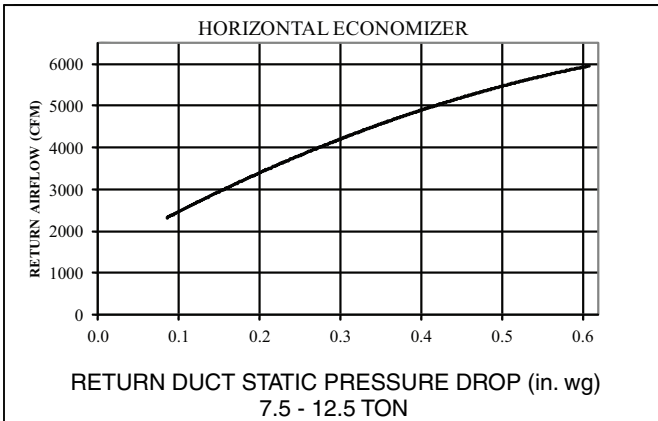

Return air pressure drop — 7<sup>1</sup>/<sub>2</sub> to 12<sup>1</sup>/<sub>2</sub> tons

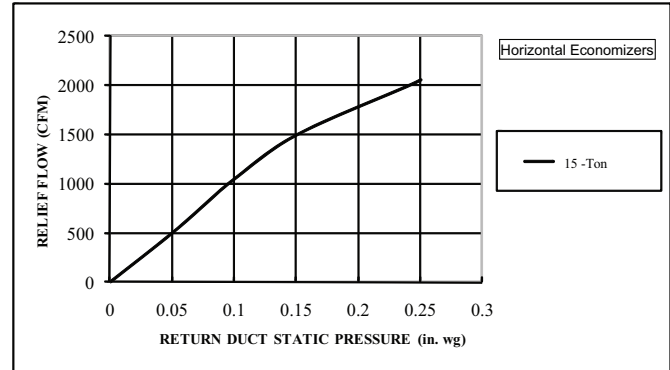

Barometric relief flow capacity - vertical 15 tons

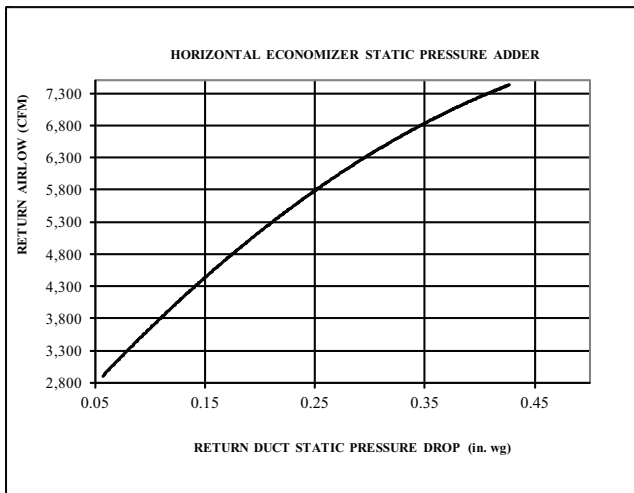

Return air pressure drop - horizontal 15 ton

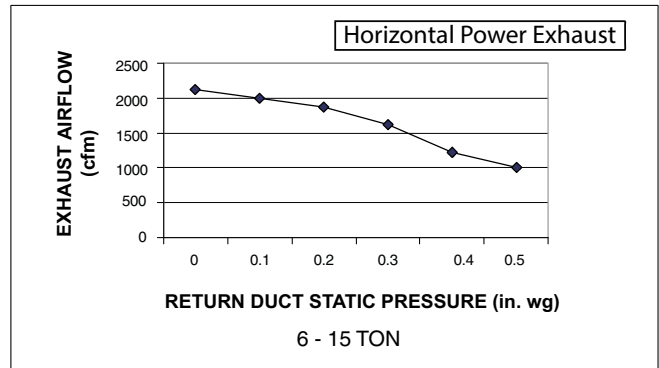

Horizontal power exhaust performance

## GENERAL FAN PERFORMANCE NOTES

1. Interpolation is permissible. Do not extrapolate.
2. External static pressure is the static pressure difference between the return duct and the supply duct plus the static pressure caused by any factory-installed options (FIOPs) or accessories.
3. Tabular data accounts for pressure loss due to clean filters, high gas heat, unit casing, and wet coils. Factory options and accessories may add static pressure losses. Selection software is available, through your salesperson, to help you select the best motor/drive combination for your application.
4. The fan performance tables offer motor/drive recommendations. In cases when two motor/drive combinations would work, Carrier recommends the lower horsepower option.
5. For information on the electrical properties of Carrier motors, please see the Electrical information section of this book.
6. For more information on the performance limits of Carrier motors, see the application data section of this book.
7. The EPACT (Energy Policy Act of 1992) regulates energy requirements for specific types of indoor fan motors. Motors regulated by EPACT include any general purpose, T-frame (three-digit, 143 and larger), single-speed, foot mounted, polyphase, squirrel cage induction motors of NEMA (National Electrical Manufacturers Association) design A and B, manufactured for use in the United States. Ranging from 1 to 200 Hp, these continuous-duty motors operate on 230 and 460 volt, 60 Hz power. If a motor does not fit into these specifications, the motor does not have to be replaced by an EPACT compliant energy efficient motor. Variable speed motors are exempt from EPACT compliance requirements. Therefore, the indoor fan motors for Carrier 48TC\*\*07-16 units are exempt from these requirements.

### PULLEY ADJUSTMENT — VERTICAL

48TC UNIT	MOTOR/DRIVE COMBO	MOTOR PULLEY TURNS OPEN (RPM)										
		0.0	0.5	1.0	1.5	2.0	2.5	3.0	3.5	4.0	4.5	5.0
07	Standard Static	1457	1419	1380	1342	1303	1265	1227	1188	1150	1111	1073
	Medium Static	1518	1484	1449	1415	1380	1346	1311	1277	1242	1208	1173
	High Static	1550	1542	1535	1527	1520	1512	1504	1497	1489	1482	1474
08	Standard Static	747	721	695	670	644	618	592	566	541	515	489
	Medium Static	949	927	906	884	863	841	819	798	776	755	733
	High Static*	1102	1083	1063	1044	1025	1006	986	967	948	928	909
09	Standard Static	733	712	690	669	647	626	604	583	561	540	518
	Medium Static	936	911	887	862	838	813	788	764	739	715	690
	High Static	1084	1059	1035	1010	986	961	936	912	887	863	838
12	Standard Static	838	813	789	764	739	715	690	665	640	616	591
	Medium Static	1084	1059	1035	1010	986	961	936	912	887	863	838
	High Static	1240	1218	1196	1175	1153	1131	1109	1087	1066	1044	1022
14	Standard Static	843	824	805	786	767	748	728	709	690	671	652
	Medium Static	1084	1059	1035	1010	986	961	936	912	887	863	838
	High Static	1240	1218	1196	1175	1153	1131	1109	1087	1066	1044	1022
16	Standard Static	676	659	642	625	608	592	575	558	541	524	507
	Medium Static	851	829	806	784	761	739	717	694	672	649	627
	High Static	955	937	919	901	883	866	848	830	812	794	776

\*High static option not available on 48TC-M08 units.  
NOTE: Do not adjust pulley further than 5 turns open.

 — Factory settings

**48TC\*\*07 — 6 TON HORIZONTAL UNIT**  
 (For more information, see General Fan Performance Notes on page 51.)

CFM	Available External Static Pressure (in. wg)									
	0.2		0.4		0.6		0.8		1.0	
	RPM	BHP	RPM	BHP	RPM	BHP	RPM	BHP	RPM	BHP
1800	913	0.64	1010	0.80	1098	0.98	1178	1.16	1252	1.35
1950	972	0.78	1065	0.96	1148	1.14	1226	1.34	1298	1.54
2100	1032	0.95	1120	1.14	1200	1.33	1275	1.54	1345	1.75
2250	1093	1.14	1177	1.34	1254	1.55	1325	1.76	1393	1.98
2400	1155	1.36	1234	1.57	1308	1.78	1377	2.01	1443	2.24
2550	1217	1.60	1293	1.82	1363	2.05	1430	2.28	1494	2.53
2700	1280	1.87	1352	2.10	1420	2.34	1484	2.59	1546	2.84
2850	1343	2.17	1412	2.42	1477	2.67	1539	2.93	—	—
3000	1406	2.50	1472	2.76	1535	3.03	—	—	—	—

CFM	Available External Static Pressure (in. wg)									
	1.2		1.4		1.6		1.8		2.0	
	RPM	BHP	RPM	BHP	RPM	BHP	RPM	BHP	RPM	BHP
1800	1322	1.56	1388	1.77	1451	1.98	1510	2.21	—	—
1950	1366	1.75	1430	1.97	1491	2.20	1550	2.43	—	—
2100	1411	1.97	1473	2.20	1533	2.43	—	—	—	—
2250	1457	2.21	1518	2.45	—	—	—	—	—	—
2400	1505	2.48	—	—	—	—	—	—	—	—
2550	—	—	—	—	—	—	—	—	—	—
2700	—	—	—	—	—	—	—	—	—	—
2850	—	—	—	—	—	—	—	—	—	—
3000	—	—	—	—	—	—	—	—	—	—

LEGEND

- Standard static 1073-1457 RPM, 2.4 Max BHP
- Medium static 1173-1518 RPM, 2.9 Max BHP
- High static 1474-1550 RPM, 3.7 Max BHP



**48TC\*\*07 — 6 TON VERTICAL UNIT**  
 (For more information, see General Fan Performance Notes on page 51.)

CFM	Available External Static Pressure (in. wg)									
	0.2		0.4		0.6		0.8		1.0	
	RPM	BHP	RPM	BHP	RPM	BHP	RPM	BHP	RPM	BHP
1800	967	0.63	1075	0.80	1170	0.97	1255	1.13	1333	1.28
1950	1029	0.77	1132	0.96	1223	1.14	1306	1.32	1382	1.49
2100	1091	0.93	1189	1.14	1278	1.33	1358	1.52	1433	1.71
2250	1154	1.11	1248	1.33	1333	1.55	1411	1.75	1484	1.96
2400	1218	1.32	1308	1.55	1390	1.78	1466	2.01	1537	2.23
2550	1283	1.55	1369	1.80	1448	2.05	1521	2.29	—	—
2700	1348	1.80	1431	2.07	1507	2.33	—	—	—	—
2850	1414	2.09	1493	2.37	—	—	—	—	—	—
3000	1479	2.40	—	—	—	—	—	—	—	—

CFM	Available External Static Pressure (in. wg)									
	1.2		1.4		1.6		1.8		2.0	
	RPM	BHP	RPM	BHP	RPM	BHP	RPM	BHP	RPM	BHP
1800	1406	1.43	1475	1.58	1540	1.72	—	—	—	—
1950	1454	1.65	1521	1.82	—	—	—	—	—	—
2100	1502	1.89	—	—	—	—	—	—	—	—
2250	—	—	—	—	—	—	—	—	—	—
2400	—	—	—	—	—	—	—	—	—	—
2550	—	—	—	—	—	—	—	—	—	—
2700	—	—	—	—	—	—	—	—	—	—
2850	—	—	—	—	—	—	—	—	—	—
3000	—	—	—	—	—	—	—	—	—	—

LEGEND

- Standard static 1073-1457 RPM, 2.4 Max BHP
- Medium static 1173-1518 RPM, 2.9 Max BHP
- High static 1474-1550 RPM, 3.7 Max BHP

**48TC\*\*08 — 7.5 TON HORIZONTAL UNIT**  
(For more information, see General Fan Performance Notes on page 51.)

CFM	Available External Static Pressure (in. wg)									
	0.2		0.4		0.6		0.8		1.0	
	RPM	BHP	RPM	BHP	RPM	BHP	RPM	BHP	RPM	BHP
2250	505	0.52	586	0.73	657	0.97	722	1.22	782	1.50
2438	533	0.62	610	0.85	679	1.09	742	1.36	800	1.65
2625	562	0.74	635	0.98	701	1.23	762	1.51	819	1.81
2813	591	0.88	661	1.13	725	1.39	783	1.68	839	1.98
3000	621	1.03	688	1.29	749	1.57	806	1.87	859	2.18
3188	652	1.21	715	1.48	774	1.77	829	2.07	881	2.40
3375	682	1.40	743	1.68	800	1.98	853	2.30	903	2.63
3563	713	1.61	772	1.91	826	2.22	878	2.55	927	2.89
3750	745	1.85	801	2.15	853	2.48	903	2.82	951	3.18

CFM	Available External Static Pressure (in. wg)									
	1.2		1.4		1.6		1.8		2.0	
	RPM	BHP	RPM	BHP	RPM	BHP	RPM	BHP	RPM	BHP
2250	838	1.81	891	2.12	941	2.46	988	2.82	1033	3.19
2438	854	1.96	906	2.28	955	2.63	1001	2.99	1046	3.37
2625	872	2.12	922	2.46	970	2.81	1016	3.17	1060	3.56
2813	890	2.31	940	2.65	986	3.01	1031	3.38	1074	3.77
3000	910	2.51	958	2.86	1004	3.23	1048	3.61	1090	4.01
3188	930	2.74	977	3.10	1022	3.47	1065	3.86	<b>1107</b>	<b>4.26</b>
3375	951	2.99	997	3.35	1041	3.74	1083	4.13	<b>1124</b>	<b>4.54</b>
3563	973	3.26	1018	3.63	1061	4.02	1103	4.43	—	—
3750	996	3.55	1040	3.93	1082	4.34	—	—	—	—

LEGEND

- Standard static 489-747 RPM, 1.7 Max BHP
- Medium static 733-949 RPM, 2.9 Max BHP
- High static 909-1102 RPM, 4.7 Max BHP
- BOLD** — Indicates field supplied drive.



**48TC\*\*08 — 7.5 TON VERTICAL UNIT**  
 (For more information, see General Fan Performance Notes on page 51.)

CFM	Available External Static Pressure (in. wg)									
	0.2		0.4		0.6		0.8		1.0	
	RPM	BHP	RPM	BHP	RPM	BHP	RPM	BHP	RPM	BHP
2250	513	0.54	595	0.76	665	1.01	728	1.27	786	1.56
2438	541	0.65	620	0.89	688	1.14	750	1.42	806	1.71
2625	570	0.77	645	1.02	712	1.29	772	1.58	827	1.88
2813	600	0.91	672	1.18	736	1.46	794	1.76	848	2.07
3000	629	1.07	699	1.35	761	1.64	818	1.95	871	2.28
3188	660	1.25	726	1.54	787	1.85	842	2.17	894	2.51
3375	690	1.45	754	1.75	813	2.07	867	2.41	917	2.76
3563	721	1.67	783	1.98	840	2.32	892	2.67	941	3.03
3750	752	1.91	812	2.24	867	2.59	918	2.95	966	3.32

CFM	Available External Static Pressure (in. wg)									
	1.2		1.4		1.6		1.8		2.0	
	RPM	BHP	RPM	BHP	RPM	BHP	RPM	BHP	RPM	BHP
2250	839	1.86	889	2.18	935	2.52	980	2.87	1022	3.23
2438	858	2.02	907	2.35	953	2.70	997	3.06	1039	3.43
2625	878	2.20	926	2.54	972	2.89	1015	3.26	1056	3.64
2813	899	2.40	946	2.75	991	3.11	1033	3.49	1074	3.88
3000	920	2.62	966	2.98	1010	3.35	1052	3.74	1093	4.14
3188	942	2.86	987	3.23	1031	3.61	1072	4.01	<b>1112</b>	<b>4.42</b>
3375	964	3.12	1009	3.50	1052	3.89	1093	4.30	—	—
3563	988	3.41	1032	3.80	1074	4.20	<b>1114</b>	<b>4.61</b>	—	—
3750	1011	3.71	1054	4.11	1096	4.53	—	—	—	—

LEGEND

- Std static - 489-747 RPM, 1.7 Max BHP
- Med static - 733-949 RPM, 2.9 Max BHP
- High static - 909-1102 RPM, 4.7 Max BHP
- BOLD** — Indicates field supplied drive.

**48TC\*\*09 — 8.5 TON HORIZONTAL UNIT**  
 (For more information, see General Fan Performance Notes on page 51.)

CFM	Available External Static Pressure (in. wg)									
	0.2		0.4		0.6		0.8		1.0	
	RPM	BHP	RPM	BHP	RPM	BHP	RPM	BHP	RPM	BHP
2550	497	0.48	579	0.61	651	0.75	717	0.90	777	1.05
2763	524	0.58	602	0.72	671	0.87	735	1.03	794	1.19
2975	551	0.70	626	0.86	693	1.01	754	1.18	812	1.35
3188	580	0.84	651	1.00	716	1.17	775	1.34	831	1.52
3400	609	1.00	677	1.17	739	1.35	797	1.53	851	1.71
3613	638	1.17	703	1.35	763	1.54	819	1.73	871	1.93
3825	668	1.37	730	1.56	788	1.76	842	1.96	893	2.16
4038	698	1.59	758	1.79	813	2.00	866	2.20	915	2.42
4250	728	1.83	786	2.04	839	2.26	890	2.47	938	2.70

CFM	Available External Static Pressure (in. wg)									
	1.2		1.4		1.6		1.8		2.0	
	RPM	BHP	RPM	BHP	RPM	BHP	RPM	BHP	RPM	BHP
2550	833	1.21	886	1.38	936	1.56	984	1.74	1029	1.93
2763	849	1.36	900	1.53	950	1.72	996	1.90	1041	2.10
2975	865	1.52	916	1.70	964	1.89	1010	2.09	1054	2.29
3188	883	1.70	933	1.89	980	2.09	1025	2.29	1068	2.50
3400	902	1.90	950	2.10	996	2.30	1041	2.51	1083	2.73
3613	921	2.13	969	2.33	1014	2.54	1057	2.76	<b>1099</b>	<b>2.98</b>
3825	941	2.37	988	2.58	1032	2.80	1075	3.02	<b>1116</b>	<b>3.25</b>
4038	963	2.63	1008	2.86	1051	3.08	<b>1093</b>	<b>3.31</b>	<b>1133</b>	<b>3.55</b>
4250	984	2.92	1029	3.15	1071	3.39	<b>1112</b>	<b>3.63</b>	—	—

LEGEND

- Std static - 518-733 RPM, 1.7 Max BHP
- Med static - 690-936 RPM, 2.4 Max BHP
- High static - 838-1084 RPM, 3.7 Max BHP
- BOLD** — Indicates field supplied drive.





**48TC\*\*09 — 8.5 TON VERTICAL UNIT**  
 (For more information, see General Fan Performance Notes on page 51.)

CFM	Available External Static Pressure (in. wg)									
	0.2		0.4		0.6		0.8		1.0	
	RPM	BHP	RPM	BHP	RPM	BHP	RPM	BHP	RPM	BHP
2550	526	0.51	600	0.65	666	0.79	727	0.93	783	1.07
2763	557	0.62	627	0.77	690	0.92	749	1.08	804	1.23
2975	588	0.75	655	0.91	716	1.08	772	1.24	825	1.40
3188	621	0.90	684	1.07	743	1.25	797	1.42	848	1.60
3400	653	1.06	714	1.25	770	1.44	822	1.62	872	1.81
3613	687	1.25	744	1.45	798	1.65	849	1.84	897	2.04
3825	720	1.45	775	1.67	827	1.88	876	2.09	922	2.30
4038	754	1.69	807	1.91	856	2.13	904	2.35	949	2.57
4250	788	1.94	839	2.17	886	2.41	932	2.64	976	2.88

CFM	Available External Static Pressure (in. wg)									
	1.2		1.4		1.6		1.8		2.0	
	RPM	BHP	RPM	BHP	RPM	BHP	RPM	BHP	RPM	BHP
2550	836	1.20	886	1.34	934	1.48	979	1.61	1022	1.74
2763	855	1.37	904	1.52	950	1.67	995	1.82	1037	1.97
2975	875	1.56	923	1.72	968	1.88	1012	2.04	1053	2.20
3188	897	1.77	943	1.94	987	2.11	1030	2.29	1071	2.46
3400	919	1.99	964	2.18	1007	2.36	1049	2.55	<b>1089</b>	<b>2.73</b>
3613	943	2.24	986	2.44	1029	2.63	1069	2.83	<b>1108</b>	<b>3.02</b>
3825	967	2.51	1010	2.71	1051	2.92	<b>1090</b>	<b>3.13</b>	<b>1129</b>	<b>3.34</b>
4038	992	2.80	1034	3.02	1074	3.24	<b>1112</b>	<b>3.46</b>	<b>1150</b>	<b>3.68</b>
4250	1018	3.11	1058	3.34	<b>1097</b>	<b>3.57</b>	—	—	—	—

LEGEND

- Std static - 518-733 RPM, 1.7 Max BHP
- Med static - 690-936 RPM, 2.4 Max BHP
- High static - 838-1084 RPM, 3.7 Max BHP
- BOLD** — Indicates field supplied drive.

**48TC\*\*12 — 10 TON HORIZONTAL UNIT**  
 (For more information, see General Fan Performance Notes on page 51.)

CFM	Available External Static Pressure (in. wg)									
	0.2		0.4		0.6		0.8		1.0	
	RPM	BHP	RPM	BHP	RPM	BHP	RPM	BHP	RPM	BHP
3000	579	0.70	660	0.89	732	1.09	799	1.29	860	1.50
3250	613	0.85	690	1.06	760	1.27	823	1.49	883	1.71
3500	648	1.03	721	1.25	788	1.48	850	1.71	907	1.95
3750	683	1.23	753	1.47	817	1.71	877	1.96	933	2.21
4000	719	1.45	786	1.71	848	1.97	905	2.23	959	2.50
4250	756	1.71	819	1.98	879	2.26	934	2.53	987	2.81
4500	792	1.99	853	2.28	910	2.57	964	2.87	1015	3.16
4750	830	2.31	888	2.62	943	2.92	995	3.23	1044	3.54
5000	867	2.66	923	2.98	976	3.30	1026	3.63	1074	3.95

CFM	Available External Static Pressure (in. wg)									
	1.2		1.4		1.6		1.8		2.0	
	RPM	BHP	RPM	BHP	RPM	BHP	RPM	BHP	RPM	BHP
3000	917	1.70	970	1.91	1021	2.13	1070	2.34	1117	2.56
3250	938	1.93	991	2.16	1041	2.38	1089	2.61	1134	2.85
3500	961	2.18	1013	2.42	1062	2.66	1108	2.91	1153	3.15
3750	985	2.46	1035	2.71	1083	2.97	1129	3.23	1173	3.49
4000	1011	2.76	1059	3.03	1106	3.30	1151	3.58	1194	3.85
4250	1037	3.09	1084	3.38	1130	3.66	1174	3.95	1216	4.24
4500	1064	3.46	1110	3.76	1155	4.06	1198	4.36	1239	4.66
4750	1091	3.85	1137	4.16	1180	4.48	—	—	—	—
5000	1120	4.28	1164	4.61	—	—	—	—	—	—

**LEGEND**

- Std static - 591-838 RPM, 2.4 Max BHP
- Med static - 838-1084 RPM, 3.7 Max BHP
- High static - 1022-1240 RPM, 4.7 Max BHP



**48TC\*\*12 — 10 TON VERTICAL UNIT**  
 (For more information, see General Fan Performance Notes on page 51.)

CFM	Available External Static Pressure (in. wg)									
	0.2		0.4		0.6		0.8		1.0	
	RPM	BHP	RPM	BHP	RPM	BHP	RPM	BHP	RPM	BHP
3000	616	0.79	689	0.97	757	1.16	821	1.36	882	1.57
3250	655	0.96	724	1.16	788	1.37	849	1.58	907	1.80
3500	695	1.17	760	1.38	821	1.60	879	1.83	934	2.06
3750	736	1.41	797	1.63	855	1.86	910	2.10	963	2.35
4000	777	1.68	834	1.91	889	2.16	942	2.41	993	2.67
4250	818	1.98	873	2.23	925	2.49	976	2.75	1025	3.02
4500	860	2.32	912	2.58	962	2.85	1010	3.13	1057	3.41
4750	902	2.69	951	2.97	999	3.26	1046	3.55	1091	3.84
5000	944	3.11	991	3.40	1037	3.70	1082	4.00	1125	4.31

CFM	Available External Static Pressure (in. wg)									
	1.2		1.4		1.6		1.8		2.0	
	RPM	BHP	RPM	BHP	RPM	BHP	RPM	BHP	RPM	BHP
3000	939	1.79	994	2.01	1047	2.24	1098	2.47	1147	2.71
3250	962	2.03	1015	2.26	1066	2.50	1115	2.75	1163	3.00
3500	987	2.30	1038	2.54	1088	2.80	1135	3.05	1181	3.32
3750	1014	2.60	1063	2.86	1111	3.12	1157	3.39	1202	3.66
4000	1042	2.93	1090	3.20	1136	3.48	1180	3.76	1224	4.04
4250	1072	3.30	1118	3.58	1162	3.87	1205	4.16	<b>1247</b>	<b>4.46</b>
4500	1103	3.70	1147	4.00	1190	4.29	1232	4.60	—	—
4750	1135	4.14	1177	4.45	—	—	—	—	—	—
5000	1167	4.63	—	—	—	—	—	—	—	—

LEGEND

- Std static - 591-838 RPM, 2.4 Max BHP
- Med static - 838-1084 RPM, 3.7 Max BHP
- High static - 1022-1240 RPM, 4.7 Max BHP
- BOLD** — Indicates field supplied drive.

**48TC\*\*14 — 12.5 TON HORIZONTAL UNIT**  
(For more information, see General Fan Performance Notes on page 51.)

CFM	Available External Static Pressure (in. wg)									
	0.2		0.4		0.6		0.8		1.0	
	RPM	BHP	RPM	BHP	RPM	BHP	RPM	BHP	RPM	BHP
3438	639	0.98	713	1.20	781	1.43	843	1.65	901	1.88
3750	683	1.23	753	1.47	817	1.71	877	1.96	933	2.21
4063	728	1.52	794	1.78	855	2.04	912	2.31	966	2.57
4375	774	1.85	836	2.13	894	2.41	949	2.70	1001	2.98
4688	820	2.23	879	2.53	935	2.83	987	3.14	1037	3.44
5000	867	2.66	923	2.98	976	3.30	1026	3.63	1074	3.95
5313	914	3.15	967	3.49	<b>1018</b>	<b>3.83</b>	1066	4.17	1112	4.52
5625	962	3.69	<b>1012</b>	<b>4.05</b>	1061	4.42	—	—	—	—
5938	<b>1009</b>	<b>4.30</b>	1058	4.68	—	—	—	—	—	—
6250	—	—	—	—	—	—	—	—	—	—

CFM	Available External Static Pressure (in. wg)									
	1.2		1.4		1.6		1.8		2.0	
	RPM	BHP	RPM	BHP	RPM	BHP	RPM	BHP	RPM	BHP
3438	955	2.12	1007	2.35	1056	2.59	1103	2.83	1148	3.08
3750	985	2.46	1035	2.71	1083	2.97	1129	3.23	1173	3.49
4063	1017	2.84	1066	3.12	1112	3.39	1157	3.67	1200	3.95
4375	1050	3.27	1097	3.56	1142	3.86	1186	4.15	1228	4.45
4688	1084	3.75	1130	4.06	1174	4.37	1216	4.68	—	—
5000	1120	4.28	1164	4.61	—	—	—	—	—	—
5313	—	—	—	—	—	—	—	—	—	—
5625	—	—	—	—	—	—	—	—	—	—
5938	—	—	—	—	—	—	—	—	—	—
6250	—	—	—	—	—	—	—	—	—	—

LEGEND

- Std static - 652-843 RPM, 2.9 Max BHP
- Med static - 838-1084 RPM, 3.7 Max BHP
- High static - 1022-1240 RPM, 4.7 Max BHP
- BOLD** — Indicates field supplied drive.



**48TC\*\*14 — 12.5 TON VERTICAL UNIT**  
 (For more information, see General Fan Performance Notes on page 51.)

CFM	Available External Static Pressure (in. wg)									
	0.2		0.4		0.6		0.8		1.0	
	RPM	BHP	RPM	BHP	RPM	BHP	RPM	BHP	RPM	BHP
3438	685	1.12	751	1.32	813	1.54	871	1.76	927	1.99
3750	736	1.41	797	1.63	855	1.86	910	2.10	963	2.35
4063	787	1.75	844	1.99	898	2.24	951	2.49	1001	2.75
4375	839	2.14	892	2.40	943	2.67	993	2.94	1041	3.21
4688	891	2.60	941	2.87	990	3.15	1037	3.44	1082	3.73
5000	944	3.11	991	3.40	1037	3.70	1082	4.00	1125	4.31
5313	997	3.69	1042	4.00	1085	4.32	1128	4.64	—	—
5625	<b>1051</b>	<b>4.34</b>	<b>1093</b>	<b>4.67</b>	—	—	—	—	—	—
5938	—	—	—	—	—	—	—	—	—	—
6250	—	—	—	—	—	—	—	—	—	—

CFM	Available External Static Pressure (in. wg)									
	1.2		1.4		1.6		1.8		2.0	
	RPM	BHP	RPM	BHP	RPM	BHP	RPM	BHP	RPM	BHP
3438	981	2.23	1032	2.47	1082	2.72	1130	2.97	1177	3.23
3750	1014	2.60	1063	2.86	1111	3.12	1157	3.39	1202	3.66
4063	1049	3.02	1097	3.29	1142	3.57	1186	3.85	1230	4.14
4375	1087	3.49	1132	3.78	1176	4.08	1218	4.37	<b>1260</b>	<b>4.68</b>
4688	1126	4.03	1169	4.33	1211	4.64	—	—	—	—
5000	1167	4.63	—	—	—	—	—	—	—	—
5313	—	—	—	—	—	—	—	—	—	—
5625	—	—	—	—	—	—	—	—	—	—
5938	—	—	—	—	—	—	—	—	—	—
6250	—	—	—	—	—	—	—	—	—	—

LEGEND

- Std static - 652-843 RPM, 2.9 Max BHP
- Med static - 838-1084 RPM, 3.7 Max BHP
- High static - 1022-1240 RPM, 4.7 Max BHP
- BOLD** — Indicates field supplied drive.

# Fan data (cont)



## 48TC\*\*16 — 15 TON HORIZONTAL UNIT

(For more information, see General Fan Performance Notes on page 51.)

CFM	Available External Static Pressure (in. wg)									
	0.2		0.4		0.6		0.8		1.0	
	RPM	BHP	RPM	BHP	RPM	BHP	RPM	BHP	RPM	BHP
4500	479	0.97	540	1.23	596	1.50	651	1.80	703	2.13
4875	508	1.19	566	1.47	619	1.75	670	2.06	719	2.39
5250	537	1.43	592	1.73	643	2.03	691	2.35	737	2.69
5625	566	1.71	619	2.03	667	2.35	713	2.68	757	3.03
6000	596	2.02	646	2.36	692	2.70	736	3.05	778	3.41
6375	625	2.36	674	2.73	718	3.09	760	3.46	800	3.83
6750	655	2.75	701	3.14	744	3.52	785	3.91	824	4.30
7125	685	3.17	729	3.58	771	3.99	810	4.40	848	4.81
7500	715	3.64	<b>758</b>	<b>4.07</b>	798	4.50	836	4.93	872	5.36

CFM	Available External Static Pressure (in. wg)									
	1.2		1.4		1.6		1.8		2.0	
	RPM	BHP	RPM	BHP	RPM	BHP	RPM	BHP	RPM	BHP
4500	755	2.48	805	2.87	853	3.28	900	3.72	945	4.17
4875	768	2.75	815	3.14	862	3.55	907	3.99	951	4.45
5250	783	3.06	828	3.45	872	3.86	916	4.30	<b>958</b>	<b>4.77</b>
5625	800	3.40	843	3.80	885	4.21	926	4.66	<b>967</b>	<b>5.12</b>
6000	819	3.79	860	4.19	900	4.61	939	5.06	<b>978</b>	<b>5.53</b>
6375	840	4.23	878	4.63	916	5.06	954	5.51	<b>991</b>	<b>5.98</b>
6750	861	4.70	898	5.12	935	5.56	<b>971</b>	<b>6.01</b>	—	—
7125	884	5.23	919	5.66	—	—	—	—	—	—
7500	907	5.79	—	—	—	—	—	—	—	—

### LEGEND

- Std static - 507-676 RPM, 2.9 Max BHP
- Med static - 627-851 RPM, 3.7 Max BHP
- High static - 776-955 RPM
- Voltage - 208v / 230v / 460v / 575v
- Max BHP 6.5 / 6.9 / 7.0 / 8.3
- BOLD** — Indicates field supplied drive.



**48TC\*\*16 — 15 TON VERTICAL UNIT**  
 (For more information, see General Fan Performance Notes on page 51.)

CFM	Available External Static Pressure (in. wg)									
	0.2		0.4		0.6		0.8		1.0	
	RPM	BHP	RPM	BHP	RPM	BHP	RPM	BHP	RPM	BHP
4500	487	0.98	552	1.26	610	1.55	665	1.86	718	2.20
4875	515	1.18	578	1.49	633	1.80	685	2.13	735	2.47
5250	544	1.42	604	1.75	657	2.09	707	2.43	754	2.78
5625	572	1.68	631	2.05	682	2.40	730	2.76	775	3.13
6000	601	1.98	657	2.37	707	2.75	753	3.13	797	3.52
6375	630	2.31	684	2.73	733	3.13	777	3.53	819	3.94
6750	659	2.68	711	3.12	759	3.55	802	3.98	843	4.40
7125	689	3.09	739	3.55	785	4.01	827	4.46	867	4.91
7500	718	3.53	<b>766</b>	<b>4.02</b>	811	4.51	852	4.98	891	5.46

CFM	Available External Static Pressure (in. wg)									
	1.2		1.4		1.6		1.8		2.0	
	RPM	BHP	RPM	BHP	RPM	BHP	RPM	BHP	RPM	BHP
4500	769	2.56	819	2.95	866	3.36	912	3.79	957	4.24
4875	784	2.84	831	3.23	877	3.65	921	4.09	<b>964</b>	<b>4.54</b>
5250	800	3.16	845	3.56	889	3.98	932	4.43	<b>974</b>	<b>4.89</b>
5625	819	3.52	862	3.93	903	4.36	944	4.81	<b>985</b>	<b>5.28</b>
6000	839	3.92	880	4.34	920	4.77	<b>959</b>	<b>5.23</b>	<b>997</b>	<b>5.70</b>
6375	860	4.36	899	4.79	937	5.23	<b>975</b>	<b>5.70</b>	—	—
6750	882	4.84	920	5.28	957	5.74	—	—	—	—
7125	904	5.36	941	5.82	—	—	—	—	—	—
7500	928	5.93	—	—	—	—	—	—	—	—

LEGEND

- Std static - 507-676 RPM, 2.9 Max BHP
- Med static - 627-851 RPM, 3.7 Max BHP
- High static - 776-955 RPM
- Voltage - 208v / 230v / 460v / 575v
- Max BHP 6.5 / 6.9 / 7.0 / 8.3
- BOLD** — Indicates field supplied drive.

## LEGEND AND NOTES

Applicable for Electrical Data Tables on pages 65 to 71

### LEGEND

<b>BRKR</b>	— Circuit breaker
<b>C.O.</b>	— Convenience outlet
<b>DISC</b>	— Disconnect
<b>EFF</b>	— Efficiency
<b>FLA</b>	— Full load amps
<b>IFM</b>	— Indoor fan motor
<b>LRA</b>	— Locked rotor amps
<b>MCA</b>	— Minimum circuit amps
<b>OFM</b>	— Outdoor fan motor
<b>P.E.</b>	— Power exhaust
<b>Pwr d fr/unit</b>	— Powered from unit
<b>PWRD C.O.</b>	— Powered convenience outlet
<b>RLA</b>	— Rated load amps
<b>UNPWR C.O.</b>	— Unpowered convenience outlet

### NOTES:

- In compliance with NEC requirements for multi-motor and combination load equipment (refer to NEC Articles 430 and 440), the overcurrent protective device for the unit shall be fuse or HACR breaker. Canadian units may be fuse or circuit breaker.
- Unbalanced 3-Phase Supply Voltage  
Never operate a motor where a phase imbalance in supply voltage is greater than 2%. Use the following formula to determine the percentage of voltage imbalance.

$$\% \text{ Voltage Imbalance} = 100 \times \frac{\text{max voltage deviation from average voltage}}{\text{average voltage}}$$

Example: Supply voltage is 230-3-60



AB = 224 v  
BC = 231 v  
AC = 226 v

$$\text{Average Voltage} = \frac{(224 + 231 + 226)}{3} = \frac{681}{3} = 227$$

Determine maximum deviation from average voltage.

(AB) 227-224 = 3 v

(BC) 231-227 = 4 v

(AC) 227-226 = 1 v

Maximum deviation is 4 v.

Determine percent of voltage imbalance.

$$\% \text{ Voltage Imbalance} = 100 \times \frac{4}{227} = 1.78\%$$

This amount of phase imbalance is satisfactory as it is below the maximum allowable 2%.

**IMPORTANT:** If the supply voltage phase imbalance is more than 2%, contact your local electric utility company immediately.





### SINGLE SPEED INDOOR FAN MOTOR, 6-15 TONS

UNIT SIZE	V-Ph-Hz	VOLTAGE RANGE		COMP 1		COMP 2		OFM (ea)		IFM			
		Min	Max	RLA	LRA	RLA	LRA	Watts	FLA	TYPE	EFF at Full Load	FLA	
48TC*A07 (1-Circuit/ 1-Stage Cooling)	208-3-60	187	253	19.6	136	—	—	325	1.5	STD	69%	5.2	
								325	1.5	MED	89%	8.4	
								325	1.5	HIGH	87%	10.6	
	230-3-60	187	253	19.6	136	—	—	325	1.5	STD	69%	5.2	
								325	1.5	MED	89%	8.3	
								325	1.5	HIGH	87%	10.6	
	460-3-60	414	506	8.2	66	—	—	325	0.8	STD	69%	2.6	
								325	0.8	MED	89%	4.2	
								325	0.8	HIGH	87%	5.3	
	575-3-60	518	633	6.6	55	—	—	325	0.6	STD	78%	2.0	
								325	0.6	MED	77%	2.8	
								325	0.6	HIGH	77%	2.8	
48TC*D08 (2-Circuit/ 2-Stage Cooling)	208-3-60	187	253	13.6	83	13.6	83	325	1.5	STD	87%	5.2	
								325	1.5	MED	89%	8.4	
								325	1.5	HIGH	83%	13.6	
	230-3-60	187	253	13.6	83	13.6	83	325	1.5	STD	87%	4.9	
								325	1.5	MED	89%	8.3	
								325	1.5	HIGH	83%	12.7	
	460-3-60	414	506	6.1	41	6.1	41	325	0.8	STD	87%	2.5	
								325	0.8	MED	89%	4.2	
								325	0.8	HIGH	83%	6.4	
	575-3-60	518	633	4.2	33	4.2	33	325	0.6	STD	87%	2.8	
								325	0.6	MED	77%	2.8	
								325	0.6	HIGH	81%	5.6	
48TC*M08 (1-Circuit / 2-Stage Cooling)	208-3-60	187	253	28.8	164	—	—	325	1.5	STD	87%	5.2	
								325	1.5	MED	89%	8.4	
								325	1.5	STD	87%	4.9	
	230-3-60	187	253	26.8	164	—	—	325	1.5	MED	89%	8.3	
								325	0.8	STD	87%	2.5	
								325	0.8	MED	89%	4.2	
	460-3-60	414	506	12.0	94	—	—	325	0.6	STD	87%	2.8	
								325	0.6	MED	77%	2.8	
								325	0.6	HIGH	77%	2.8	
	48TC*D09 (2-Circuit/ 2-Stage Cooling)	208-3-60	187	253	14.5	98	13.7	83	325	1.5	STD	75%	5.2
									325	1.5	MED	87%	6.9
									325	1.5	HIGH	87%	10.6
230-3-60		187	253	14.5	98	13.7	83	325	1.5	STD	75%	5.2	
								325	1.5	MED	87%	6.7	
								325	1.5	HIGH	87%	10.6	
460-3-60		414	506	6.3	55	6.2	41	325	0.8	STD	75%	2.6	
								325	0.8	MED	87%	3.4	
								325	0.8	HIGH	87%	5.3	
575-3-60		518	633	6.0	41	4.8	33	325	0.6	STD	72%	1.6	
								325	0.6	MED	78%	2.0	
								325	0.6	HIGH	77%	2.8	
48TC*M09 (1-Circuit / 2-Stage Cooling)	208-3-60	187	253	28.8	223	—	—	325	1.5	STD	75%	5.2	
								325	1.5	MED	87%	6.9	
								325	1.5	HIGH	87%	10.6	
	230-3-60	187	253	28.8	223	—	—	325	1.5	STD	75%	5.2	
								325	1.5	MED	87%	6.7	
								325	1.5	HIGH	87%	10.6	
	460-3-60	414	506	12.5	100	—	—	325	0.8	STD	75%	2.6	
								325	0.8	MED	87%	3.4	
								325	0.8	HIGH	87%	5.3	
	575-3-60	518	633	9.7	70	—	—	325	0.6	STD	72%	1.6	
								325	0.6	MED	78%	2.0	
								325	0.6	HIGH	77%	2.8	

See Legend and Notes on page 64.

## SINGLE SPEED INDOOR FAN MOTOR, 6-15 TONS (cont)

UNIT SIZE	V-Ph-Hz	VOLTAGE RANGE		COMP 1		COMP 2		OFM (ea)		IFM		
		Min	Max	RLA	LRA	RLA	LRA	Watts	FLA	TYPE	EFF at Full Load	FLA
48TC*D12 (2-Circuit/ 2-Stage Cooling)	208-3-60	187	253	15.6	110	15.9	110	325	1.5	STD	69%	5.2
								325	1.5	MED	87%	10.6
								325	1.5	HIGH	83%	13.6
	230-3-60	187	253	15.6	110	15.9	110	325	1.5	STD	69%	5.2
								325	1.5	MED	87%	10.6
								325	1.5	HIGH	83%	12.7
	460-3-60	414	506	7.7	52	7.7	52	325	0.8	STD	69%	2.6
								325	0.8	MED	87%	5.3
								325	0.8	HIGH	83%	6.4
	575-3-60	518	633	5.8	39	5.7	39	325	0.6	STD	78%	2.0
								325	0.6	MED	77%	2.8
								325	0.6	HIGH	81%	5.6
48TC*M12 (1-Circuit / 2-Stage Cooling)	208-3-60	187	253	32.5	240	—	—	325	1.5	STD	69%	5.2
								325	1.5	MED	87%	10.6
								325	1.5	HIGH	83%	13.6
	230-3-60	187	253	32.5	240	—	—	325	1.5	STD	69%	5.2
								325	1.5	MED	87%	10.6
								325	1.5	HIGH	83%	12.7
	460-3-60	414	506	14.8	130	—	—	325	0.8	STD	69%	2.6
								325	0.8	MED	87%	5.3
								325	0.8	HIGH	83%	6.4
	575-3-60	518	633	11.1	94	—	—	325	0.6	STD	78%	2.0
								325	0.6	MED	77%	2.8
								325	0.6	HIGH	81%	5.6
48TC*D14 (2-Circuit/ 2-Stage Cooling)	208-3-60	187	253	19.6	136	22.4	149	1070	6.2	STD	89%	8.4
								1070	6.2	MED	87%	10.6
								1070	6.2	HIGH	83%	13.6
	230-3-60	187	253	19.6	136	22.4	149	1070	6.2	STD	89%	8.3
								1070	6.2	MED	87%	10.6
								1070	6.2	HIGH	83%	12.7
	460-3-60	414	506	8.2	66	10.6	75	1070	3.1	STD	89%	4.2
								1070	3.1	MED	87%	5.3
								1070	3.1	HIGH	83%	6.4
	575-3-60	518	633	6.6	55	7.7	54	1070	2.5	STD	77%	2.8
								1070	2.5	MED	77%	2.8
								1070	2.5	HIGH	81%	5.6
48TC*D16 (2-Circuit/ 2-Stage Cooling)	208-3-60	187	253	25.0	164	25.0	164	280	1.5	STD	89%	8.4
								280	1.5	MED	87%	10.6
								280	1.5	HIGH	87%	17.0
								280	1.5	HIGH EFF	90%	20.4
	230-3-60	187	253	25.0	164	25.0	164	280	1.5	STD	89%	8.3
								280	1.5	MED	87%	10.6
								280	1.5	HIGH	87%	15.0
								280	1.5	HIGH EFF	90%	20.4
	460-3-60	414	506	12.2	100	12.8	100	280	0.8	STD	89%	4.2
								280	0.8	MED	87%	5.3
								280	0.8	HIGH	87%	7.6
								280	0.8	HIGH EFF	90%	10.2
575-3-60	518	633	9.8	78	9.6	78	280	0.6	STD	77%	2.8	
							280	0.6	MED	77%	2.8	
							280	0.6	HIGH	90%	6.1	
							280	0.6	HIGH EFF	94%	9.0	

See Legend and Notes on page 64.



### 1-STAGE COOLING WITH TWO-SPEED INDOOR FAN MOTOR, 6 TONS

UNIT SIZE	V-Ph-Hz	VOLTAGE RANGE		COMP 1		COMP 2		OFM (ea)		IFM		
		Min	Max	RLA	LRA	RLA	LRA	Watts	FLA	TYPE	EFF at Full Load	FLA
48TC*A07 (1-Circuit/ 1-Stage Cooling)	208-3-60	187	253	19.6	136	—	—	325	1.5	STD	0.77	7.1
								325	1.5	MED	0.85	8.6
								325	1.5	HIGH	0.82	10.8
	230-3-60	187	253	19.6	136	—	—	325	1.5	STD	0.77	6.8
								325	1.5	MED	0.85	7.8
								325	1.5	HIGH	0.82	9.8
	460-3-60	414	506	8.2	66	—	—	325	0.8	STD	0.77	3.4
								325	0.8	MED	0.85	3.8
								325	0.8	HIGH	0.82	4.9
	575-3-60	518	633	6.6	55	—	—	325	0.6	STD	0.80	3.5
								325	0.6	MED	0.84	4.5
								325	0.6	HIGH	0.84	4.5

### TWO-SPEED INDOOR FAN MOTOR, 7.5-15 TONS

UNIT SIZE	V-Ph-Hz	VOLTAGE RANGE		COMP 1		COMP 2		OFM (ea)		IFM		
		Min	Max	RLA	LRA	RLA	LRA	Watts	FLA	TYPE	EFF at Full Load	FLA
48TC*D08 (2-Circuit/ 2-Stage Cooling)	208-3-60	187	253	13.6	83	13.6	83	325	1.5	STD	0.84	5.8
								325	1.5	MED	0.85	8.6
								325	1.5	HIGH	0.84	13.6
	230-3-60	187	253	13.6	83	13.6	83	325	1.5	STD	0.84	5.6
								325	1.5	MED	0.85	7.8
								325	1.5	HIGH	0.84	12.7
	460-3-60	414	506	6.1	41	6.1	41	325	0.8	STD	0.79	2.9
								325	0.8	MED	0.85	3.8
								325	0.8	HIGH	0.84	6.4
	575-3-60	518	633	4.2	33	4.2	33	325	0.6	STD	0.81	2.8
								325	0.6	MED	0.84	4.5
								325	0.6	HIGH	0.83	6.2
48TC*D09 (2-Circuit/ 2-Stage Cooling)	208-3-60	187	253	14.5	98	13.7	83	325	1.5	STD	0.84	5.8
								325	1.5	MED	0.77	7.1
								325	1.5	HIGH	0.82	10.8
	230-3-60	187	253	14.5	98	13.7	83	325	1.5	STD	0.84	5.6
								325	1.5	MED	0.77	6.8
								325	1.5	HIGH	0.82	9.8
	460-3-60	414	506	6.3	55	6.2	41	325	0.8	STD	0.79	2.9
								325	0.8	MED	0.77	3.4
								325	0.8	HIGH	0.82	4.9
	575-3-60	518	633	6.0	41	4.8	33	325	0.6	STD	0.81	2.8
								325	0.6	MED	0.80	3.5
								325	0.6	HIGH	0.84	4.5
48TC*D12 (2-Circuit/ 2-Stage Cooling)	208-3-60	187	253	15.6	110	15.9	110	325	1.5	STD	0.77	7.1
								325	1.5	MED	0.82	10.8
								325	1.5	HIGH	0.84	13.6
	230-3-60	187	253	15.6	110	15.9	110	325	1.5	STD	0.77	6.8
								325	1.5	MED	0.82	9.8
								325	1.5	HIGH	0.84	12.7
	460-3-60	414	506	7.7	52	7.7	52	325	0.8	STD	0.77	3.4
								325	0.8	MED	0.82	4.9
								325	0.8	HIGH	0.84	6.4
	575-3-60	518	633	5.8	39	5.7	39	325	0.6	STD	0.80	3.5
								325	0.6	MED	0.84	4.5
								325	0.6	HIGH	0.83	6.2

See Legend and Notes on page 64.

# Electrical data (cont)



## TWO-SPEED INDOOR FAN MOTOR, 7.5-15 TONS (cont)

UNIT SIZE	V-Ph-Hz	VOLTAGE RANGE		COMP 1		COMP 2		OFM (ea)		IFM		
		Min	Max	RLA	LRA	RLA	LRA	Watts	FLA	TYPE	EFF at Full Load	FLA
48TC*D14 (2-Circuit/ 2-Stage Cooling)	208-3-60	187	253	19.6	136	22.4	149	1070	6.2	STD	0.85	8.6
								1070	6.2	MED	0.82	10.8
								1070	6.2	HIGH	0.84	13.6
	230-3-60	187	253	19.6	136	22.4	149	1070	6.2	STD	0.85	7.8
								1070	6.2	MED	0.82	9.8
								1070	6.2	HIGH	0.84	12.7
	460-3-60	414	506	8.2	66	10.6	75	1070	3.1	STD	0.85	3.8
								1070	3.1	MED	0.82	4.9
								1070	3.1	HIGH	0.84	6.4
	575-3-60	518	633	6.6	55	7.7	54	1070	2.5	STD	0.84	4.5
								1070	2.5	MED	0.84	4.5
								1070	2.5	HIGH	0.83	6.2
48TC*D16 (2-Circuit/ 2-Stage Cooling)	208-3-60	187	253	25.0	164	25.0	164	280	1.5	STD	0.85	8.6
								280	1.5	MED	0.82	10.8
								280	1.5	HIGH	0.90	20.4
	230-3-60	187	253	25.0	164	25.0	164	280	1.5	STD	0.85	7.8
								280	1.5	MED	0.82	9.8
								280	1.5	HIGH	0.90	20.4
	460-3-60	414	506	12.2	100	12.8	100	280	0.8	STD	0.85	3.8
								280	0.8	MED	0.82	4.9
								280	0.8	HIGH	0.90	10.2
	575-3-60	518	633	9.8	78	9.6	78	280	0.6	STD	0.84	4.5
								280	0.6	MED	0.84	4.5
								280	0.6	HIGH	0.94	9.0

See Legend and Notes on page 64.



**UNIT WIRE/FUSE OR HACR BREAKER SIZING DATA -  
1-SPEED INDOOR FAN MOTOR, 6-15 TONS**

SIZE/ CIRCUIT / STAGE	NOM. V-Ph-Hz	IFM TYPE	NO CONVENIENCE OUTLET (C.O.) or UNPWR C.O.								w/ PWRD C.O.							
			NO Power Exhaust (P.E.)				w/ P.E. (pwrd fr/ unit)				NO P.E.				w/ P.E. (pwrd fr/ unit)			
			MCA	Fuse or Hacr Brkr	DISC. SIZE		MCA	Fuse or Hacr Brkr	DISC. SIZE		MCA	Fuse or Hacr Brkr	DISC. SIZE		MCA	Fuse or Hacr Brkr	DISC. SIZE	
					FLA	LRA			FLA	LRA			FLA	LRA			FLA	LRA
48TC*AO7 (1-circuit / 1-stage cool)	208/230-3-60	STD	32	50	30	170	34	50	32	172	36	50	36	175	38	50	38	177
		MED	35/35	50/50	34/34	212	37/37	50/50	36/36	214	40/40	50/50	39/39	217	42/41	60/60	42/42	219
		HIGH	37	50	36	226	39	50	39	228	42	60	42	231	44	60	44	233
	460-3-60	STD	14	20	13	83	15	20	14	84	16	20	16	85	17	25	17	86
		MED	16	20	15	104	17	20	16	105	18	25	18	106	19	25	19	107
		HIGH	17	20	16	111	18	25	18	112	19	25	19	113	20	25	20	114
	575-3-60	STD	11	15	11	68	13	15	13	70	13	15	13	70	15	20	15	72
		MED	12	15	12	79	14	20	14	81	14	15	13	81	16	20	16	83
		HIGH	12	15	12	79	14	20	14	81	14	15	13	81	16	20	16	83
48TC*DO8 (2-circuit / 2-stage cool)	208/230-3-60	STD	39	50	41	193	43	50	45	197	44	50	46	198	48	60	51	202
		MED	42/42	50/50	44/44	246	46/46	50/50	49/49	250	47/47	60/60	50/50	251	51/51	60/60	54/54	255
		HIGH	48/47	60/50	50/49	262	51/51	60/60	55/54	266	52/52	60/60	56/55	267	56/55	60/60	60/59	271
	460-3-60	STD	18	20	19	95	20	25	21	97	21	25	21	97	22	25	23	99
		MED	20	25	21	122	22	25	23	124	22	25	23	124	24	30	25	126
		HIGH	22	25	23	130	24	30	25	132	24	30	26	132	26	30	28	134
	575-3-60	STD	13	15	13	77	17	20	17	81	14	15	15	79	18	20	19	83
		MED	14	15	14	92	18	20	19	96	16	20	16	94	19	25	21	98
		HIGH	17	20	17	106	21	25	22	110	19	20	19	108	23	25	24	112
48TC*M08 (1-circuit / 2-stage cool)	208/230-3-60	STD	42/42	60/60	40/40	208	46/46	60/60	45/44	212	47/47	60/60	46/45	213	51/50	60/60	50/50	217
		MED	45/45	60/60	44/44	244	49/49	60/60	48/48	248	50/50	60/60	49/49	249	54/54	80/80	54/54	253
	460-3-60	STD	20	30	19	116	21	30	21	118	22	30	21	118	24	30	23	120
		MED	21	30	20	134	23	30	23	136	23	30	23	136	25	30	25	138
	575-3-60	STD	16	20	15	84	20	25	19	88	17	25	17	86	21	25	21	90
		MED	16	20	15	91	20	25	19	95	17	25	17	93	21	25	21	97
48TC*DO9 (2-circuit / 2-stage cool)	208/230-3-60	STD	40	50	42	208	44	50	46	212	45	50	47	213	49	60	52	217
		MED	42/42	50/50	44/44	246	46/46	60/50	48/48	250	47/47	60/60	49/49	251	51/51	60/60	54/53	255
		HIGH	46	50	48	275	50	60	52	279	51	60	54	280	54	60	58	284
	460-3-60	STD	19	20	19	109	21	25	21	111	21	25	22	111	23	25	24	113
		MED	20	25	20	128	21	25	22	130	22	25	23	130	24	25	25	132
		HIGH	21	25	22	143	23	25	24	145	24	25	25	145	25	30	27	147
	575-3-60	STD	16	20	16	85	19	25	20	89	17	20	18	87	21	25	22	91
		MED	16	20	16	89	20	25	20	93	18	20	18	91	21	25	22	95
		HIGH	17	20	17	100	21	25	21	104	18	20	19	102	22	25	23	106
48TC*M09 (1-circuit / 2-stage cool)	208/230-3-60	STD	45	60	43	250	48	60	47	254	49	60	48	255	53	80	52	259
		MED	46/46	60/60	45/44	288	50/50	60/60	49/49	292	51/51	60/60	50/50	293	55/55	80/80	54/54	297
		HIGH	50	60	49	317	54	80	53	321	55	80	54	322	59	80	59	326
	460-3-60	STD	20	30	19	113	22	30	21	115	22	30	22	115	24	30	24	117
		MED	21	30	20	132	23	30	22	134	23	30	23	134	25	30	25	136
		HIGH	23	30	22	147	25	30	24	149	25	30	25	149	27	30	27	151
	575-3-60	STD	15	20	14	81	19	25	19	85	17	25	16	83	21	30	21	87
		MED	16	25	15	85	20	25	19	89	17	25	17	87	21	30	21	91
		HIGH	17	25	16	96	20	25	20	100	18	25	18	98	22	30	22	102

See Legend and Notes on page 64.

## UNIT WIRE/FUSE OR HACR BREAKER SIZING DATA - 1-SPEED INDOOR FAN MOTOR, 6-15 TONS (cont)

SIZE / CIRCUIT / STAGE	NOM. V-Ph-Hz	IFM TYPE	NO CONVENIENCE OUTLET (C.O.) or UNPWR C.O.								w/ PWRD C.O.							
			NO Power Exhaust (P.E.)				w/ P.E. (pwrd fr/ unit)				NO P.E.				w/ P.E. (pwrd fr/ unit)			
			MCA	Fuse or Hacr Brkr	DISC. SIZE		MCA	Fuse or Hacr Brkr	DISC. SIZE		MCA	Fuse or Hacr Brkr	DISC. SIZE		MCA	Fuse or Hacr Brkr	DISC. SIZE	
					FLA	LRA			FLA	LRA			FLA	LRA			FLA	LRA
48TC'D12 (2-circuit / 2-stage cool)	208/230-3-60	STD	44	50	46	258	48	60	50	262	49	60	51	263	53	60	56	267
		MED	50	60	52	314	53	60	56	318	54	60	57	319	58	70	62	323
		HIGH	53/52	60/60	55/54	316	56/55	60/60	60/59	320	57/56	70/60	61/60	321	61/60	70/70	65/64	325
	460-3-60	STD	22	25	23	123	24	30	25	125	24	30	25	125	26	30	27	127
		MED	25	30	26	151	26	30	28	153	27	30	28	153	29	35	30	155
		HIGH	26	30	27	152	28	30	29	154	28	30	29	154	30	35	32	156
	575-3-60	STD	17	20	17	93	20	25	21	97	18	20	19	95	22	25	23	99
		MED	17	20	18	104	21	25	22	108	19	25	20	106	23	25	24	110
		HIGH	20	25	21	118	24	30	25	122	22	25	23	120	26	30	27	124
48TC'M12 (1-circuit / 2-stage cool)	208/230-3-60	STD	49	60	47	278	53	80	51	282	54	80	52	283	58	80	57	287
		MED	55	80	53	334	58	80	57	338	59	80	59	339	63	80	63	343
		HIGH	58/57	80/80	56/55	336	61/61	80/80	61/60	340	62/62	80/80	62/61	341	66/65	80/80	66/65	345
	460-3-60	STD	23	30	22	149	25	30	24	151	25	30	24	151	27	40	26	153
		MED	26	30	25	177	28	40	27	179	28	40	27	179	30	40	30	181
		HIGH	27	40	26	178	29	40	28	180	29	40	29	180	31	45	31	182
	575-3-60	STD	18	25	16	109	21	30	21	113	19	25	18	111	23	30	23	115
		MED	18	25	17	120	22	30	22	124	20	30	19	122	24	30	24	126
		HIGH	21	30	21	134	25	30	25	138	23	30	23	136	27	30	27	140
48TC'D14 (2-circuit / 2-stage cool)	208/230-3-60	STD	63/63	80/80	65/65	389	66/66	80/80	69/69	393	67/67	80/80	71/70	394	71/71	80/80	75/75	398
		MED	65	80	68	403	69	80	72	407	70	80	73	408	73	80	78	412
		HIGH	68/67	80/80	71/70	405	72/71	80/80	75/74	409	—	—	—	—	—	—	—	—
	460-3-60	STD	29	35	30	193	31	40	32	195	31	40	33	195	33	40	35	197
		MED	30	40	31	200	32	40	33	202	33	40	34	202	34	40	36	204
		HIGH	31	40	33	201	33	40	35	203	34	40	35	203	35	45	37	205
	575-3-60	STD	22	25	23	147	26	30	27	151	24	30	24	149	27	30	29	153
		MED	22	25	23	147	26	30	27	151	24	30	24	149	27	30	29	153
		HIGH	25	30	26	161	29	35	30	165	26	30	28	163	30	35	32	167
48TC'D16 (2-circuit / 2-stage cool)	208/230-3-60	STD	70/70	80/80	72/72	412	73/73	80/80	77/77	416	74/74	90/90	78/78	417	78/78	100/100	82/82	421
		MED	72	80	75	426	76	100	79	430	77	100	80	431	80	100	85	435
		HIGH-High Efficiency	82	100	86	432	85	100	91	436	86	100	92	437	90	100	96	441
	460-3-60	STD	35	45	36	242	37	45	38	244	37	45	39	244	39	50	41	246
		MED	36	45	38	249	38	50	40	251	39	50	40	251	40	50	42	253
		HIGH-High Efficiency	41	50	43	252	43	50	45	254	43	50	46	254	45	50	48	256
	575-3-60	STD	27	30	28	184	31	40	32	188	29	35	30	186	32	40	34	190
		MED	27	30	28	184	31	40	32	188	29	35	30	186	32	40	34	190
		HIGH-High Efficiency	33	40	35	196	37	45	39	200	35	40	37	198	39	45	41	202

See Legend and Notes on page 64.



**UNIT WIRE/FUSE OR HACR BREAKER SIZING DATA -  
2-SPEED BLOWER INDOOR FAN MOTOR, 6-15 TONS**

SIZE / CIRCUIT / STAGE	NOM. V-Ph-Hz	IFM TYPE	NO CONVENIENCE OUTLET (C.O.) or UNPWR C.O.								w/ PWRD C.O.							
			NO Power Exhaust (P.E.)				w/ P.E. (pwrd fr/ unit)				NO P.E.				w/ P.E. (pwrd fr/ unit)			
			MCA	Fuse or Hacr Brkr	DISC. SIZE		MCA	Fuse or Hacr Brkr	DISC. SIZE		MCA	Fuse or Hacr Brkr	DISC. SIZE		MCA	Fuse or Hacr Brkr	DISC. SIZE	
					FLA	LRA			FLA	LRA			FLA	LRA			FLA	LRA
48TC*A07 (1-circuit / 1-stage cool)	208/230-3-60	STD	34/33	50/50	32/32	167	35/35	50/50	35/34	169	38/38	50/50	38/38	172	40/40	50/50	40/40	174
		MED	35/34	50/50	34/33	193	37/36	50/50	36/35	195	40/39	50/50	40/39	198	42/41	60/60	42/41	200
		HIGH	37/36	50/50	37/36	217	39/38	50/50	39/38	219	42/41	60/60	42/41	222	44/43	60/60	44/43	224
	460-3-60	STD	15	20	14	82	16	20	15	83	17	20	17	84	18	25	18	85
		MED	15	20	15	95	16	20	16	96	18	25	17	97	19	25	18	98
		HIGH	16	20	16	107	17	25	17	108	19	25	19	109	20	25	20	110
	575-3-60	STD	13	15	12	70	15	20	14	72	15	20	14	72	16	20	16	74
		MED	14	15	13	79	16	20	16	81	16	20	15	81	17	20	18	83
		HIGH	14	15	13	79	16	20	16	81	16	20	15	81	17	20	18	83
48TC*D08 (2-circuit / 2-stage cool)	208/230-3-60	STD	40/40	50/50	41/41	197	44/43	50/50	46/46	201	45/44	50/50	47/47	202	48/48	60/60	51/51	206
		MED	43/42	50/50	45/44	227	46/46	50/50	49/48	231	47/47	60/60	50/49	232	51/50	60/60	55/54	236
		HIGH	48/47	60/50	50/49	262	51/51	60/60	55/54	266	52/52	60/60	56/55	267	56/55	60/60	60/59	271
	460-3-60	STD	19	20	19	97	20	25	21	99	21	25	22	99	23	25	24	101
		MED	20	25	20	113	21	25	22	115	22	25	23	115	24	25	25	117
		HIGH	22	25	23	130	24	30	25	132	24	30	26	132	26	30	28	134
	575-3-60	STD	14	15	14	79	18	20	19	83	16	20	16	81	19	25	21	85
		MED	16	20	16	92	19	25	21	96	17	20	18	94	21	25	23	98
		HIGH	18	20	18	106	22	25	23	110	20	25	20	108	23	25	24	112
48TC*D09 (2-circuit / 2-stage cool)	208/230-3-60	STD	41/41	50/50	43/42	212	45/45	50/50	47/47	216	46/46	50/50	48/48	217	50/49	60/60	52/52	221
		MED	42/42	50/50	44/44	216	46/46	60/50	48/48	220	47/47	60/60	50/49	221	51/51	60/60	54/54	225
		HIGH	46/45	60/50	48/47	266	50/49	60/60	53/52	270	51/50	60/60	54/53	271	55/54	60/60	58/57	275
	460-3-60	STD	19	25	20	111	21	25	22	113	21	25	22	113	23	25	24	115
		MED	20	25	20	114	21	25	22	116	22	25	23	116	24	25	25	118
		HIGH	21	25	22	139	23	25	24	141	23	25	24	141	25	30	26	143
	575-3-60	STD	17	20	17	87	21	25	21	91	18	20	19	89	22	25	23	93
		MED	17	20	18	91	21	25	22	95	19	25	20	93	23	25	24	97
		HIGH	18	20	19	100	22	25	23	104	20	25	21	102	24	30	25	106
48TC*D12 (2-circuit / 2-stage cool)	208/230-3-60	STD	46/46	60/60	48/47	255	50/50	60/60	52/52	259	51/51	60/60	53/53	260	55/54	60/60	58/57	264
		MED	50/49	60/60	52/51	305	54/53	60/60	56/55	309	55/54	60/60	58/56	310	58/57	70/70	62/61	314
		HIGH	53/52	60/60	55/54	316	56/55	60/60	60/59	320	57/56	70/60	61/60	321	61/60	70/70	65/64	325
	460-3-60	STD	23	30	23	122	25	30	26	124	25	30	26	124	27	30	28	126
		MED	24	30	25	147	26	30	27	149	26	30	28	149	28	30	30	151
		HIGH	26	30	27	152	28	30	29	154	28	30	29	154	30	35	32	156
	575-3-60	STD	18	20	19	95	22	25	23	99	20	25	21	97	24	25	25	101
		MED	19	25	20	104	23	25	24	108	21	25	22	106	25	30	26	110
		HIGH	21	25	22	118	25	30	26	122	23	25	24	120	26	30	28	124
48TC*D14 (2-circuit / 2-stage cool)	208/230-3-60	STD	63/62	80/80	65/64	370	67/66	80/80	70/69	374	68/67	80/80	71/70	375	71/71	80/80	75/74	379
		MED	65/64	80/80	68/67	394	69/68	80/80	72/71	398	70/69	80/80	73/72	399	74/73	80/80	78/77	403
		HIGH	68/67	80/80	71/70	405	72/71	80/80	75/74	409	—	—	—	—	—	—	—	—
	460-3-60	STD	29	35	30	184	31	40	32	186	31	40	32	186	33	40	34	188
		MED	30	40	31	196	32	40	33	198	32	40	33	198	34	40	35	200
		HIGH	31	40	33	201	33	40	35	203	34	40	35	203	35	45	37	205
	575-3-60	STD	24	30	24	147	27	30	29	151	25	30	26	149	29	35	31	153
		MED	24	30	24	147	27	30	29	151	25	30	26	149	29	35	31	153
		HIGH	25	30	26	161	29	35	31	165	27	30	28	163	31	35	33	167
48TC*D16 (2-circuit / 2-stage cool)	208/230-3-60	STD	70/69	80/80	73/72	393	74/73	80/80	77/76	397	75/74	90/80	78/77	398	78/78	100/100	82/82	402
		MED	72/71	80/80	75/74	417	76/75	100/90	79/78	421	77/76	100/100	81/79	422	81/80	100/100	85/84	426
		HIGH	82	100	86	432	85	100	91	436	86	100	92	437	90	100	96	441
	460-3-60	STD	35	45	36	233	37	45	38	235	37	45	38	235	39	50	40	237
		MED	36	45	37	245	38	50	39	247	38	50	40	247	40	50	42	249
		HIGH	41	50	43	252	43	50	45	254	43	50	46	254	45	50	48	256
	575-3-60	STD	29	35	30	184	32	40	34	188	30	35	32	186	34	40	36	190
		MED	29	35	30	184	32	40	34	188	30	35	32	186	34	40	36	190
		HIGH	33	40	35	196	37	45	39	200	35	40	37	198	39	45	41	202

See Legend and Notes on page 64.

## 48TC\*\*07 CONTROL WIRING DIAGRAM

YAC CONTROL 208/230V, 460V, 575V  
04-07 TIER 1

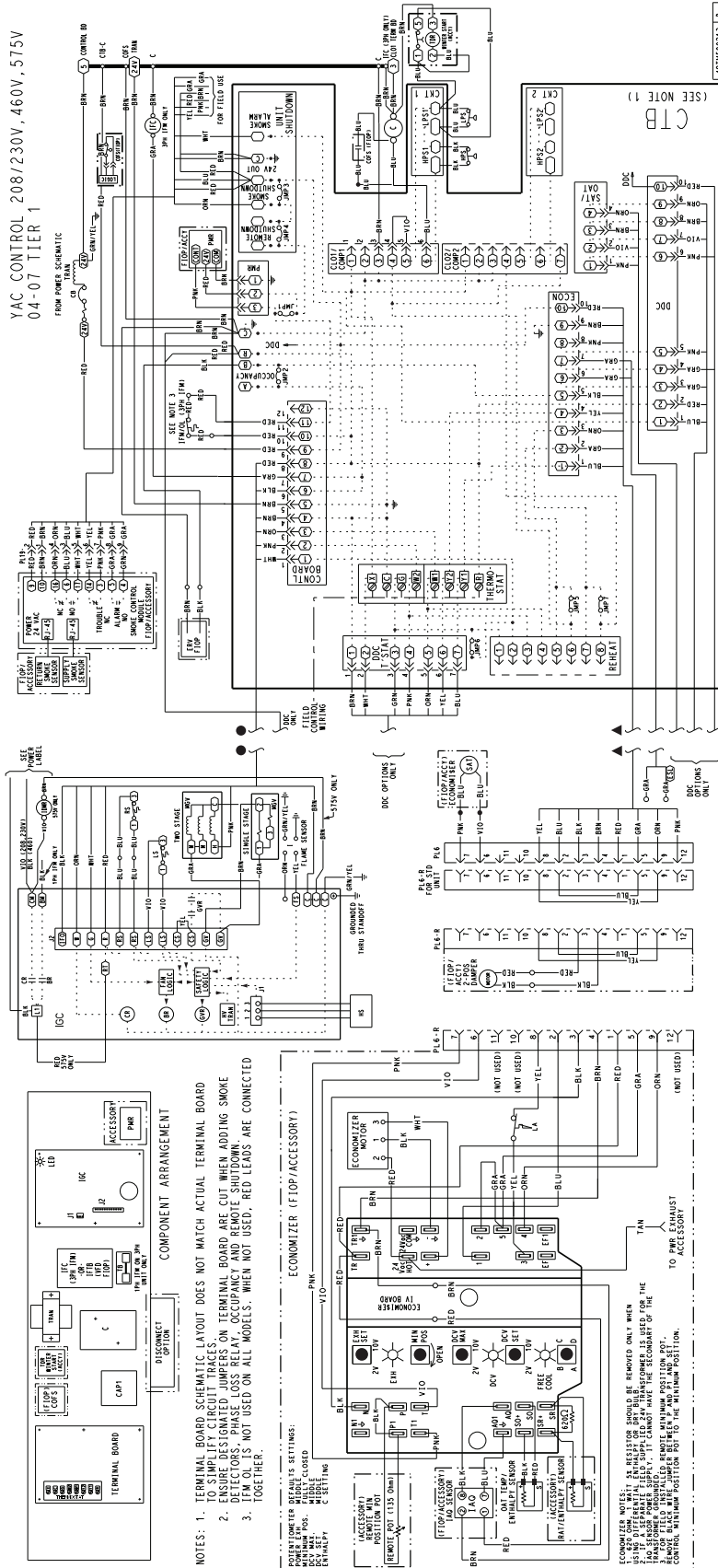



### 48TC\*08-12 CONTROL WIRING DIAGRAM

YAC CONTROL 208/230V, 460V, 575V  
 7.5-10TON YAC (2)COMPR T1  
 7.5-8.5TON YAC (2)COMPR T2

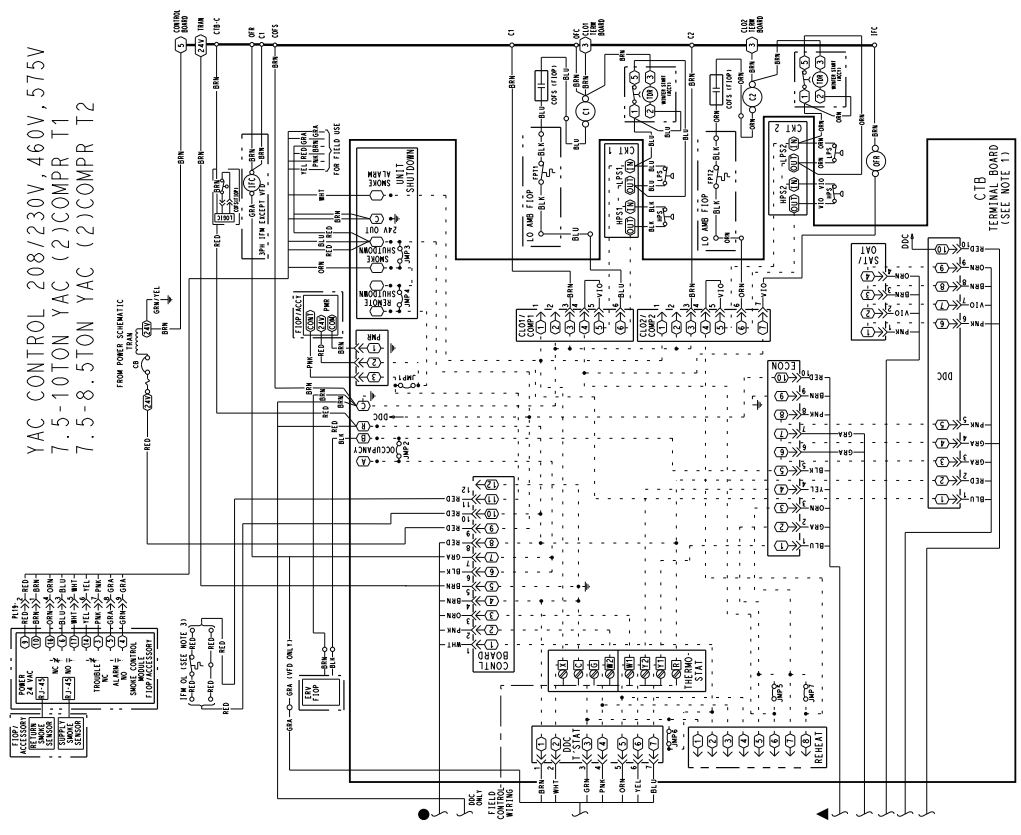

48TMS01325 17

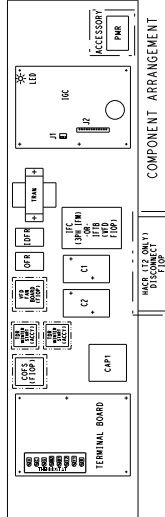
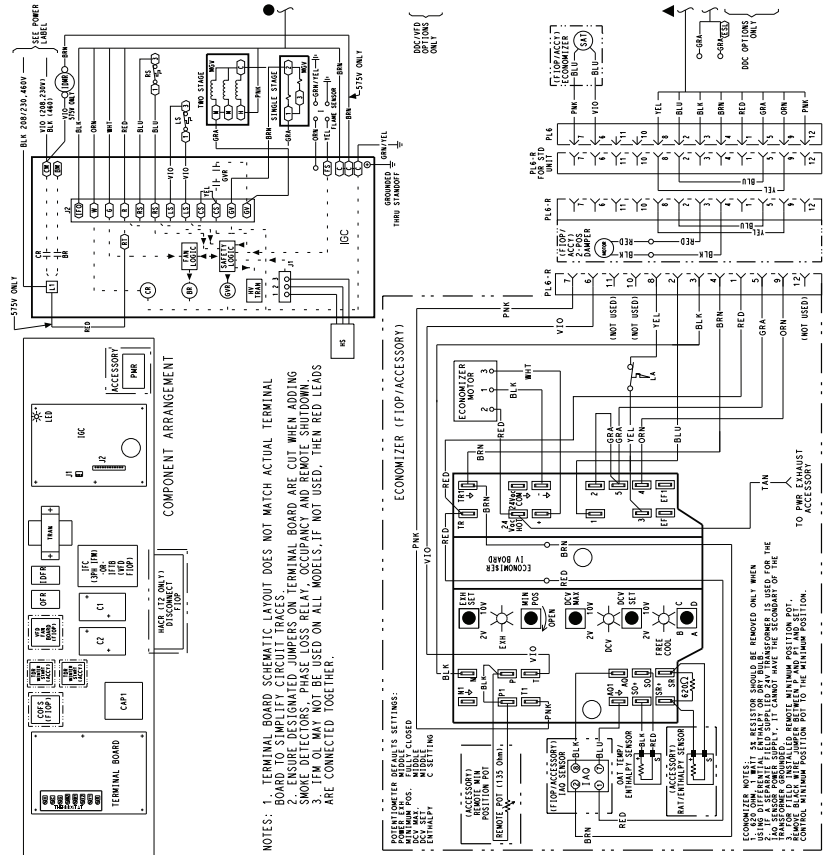

- NOTES:**
1. TERMINAL BOARD SCHEMATIC LAYOUT DOES NOT MATCH ACTUAL TERMINAL BOARD TO SIMPLIFY CIRCUIT TRACES.
  2. ENSURE DESIGNATED JUMPERS ON TERMINAL BOARD ARE CUT WHEN ADDING ECONOMIZER TO THE SYSTEM.
  3. TAN EXHAUST ACCESSORY IS A FIELD OPTION AND IS NOT SHOWN IN THIS SCHEMATIC. IT CAN ONLY BE USED ON ALL MODELS. IF NOT USED, THEN RED LEADS ARE CONNECTED TOGETHER.

- POTENTIALER DEFAULT SETTINGS:**
- 1. POSITIONER POS. - SHUT CLOSED
  - 2. POSITIONER POS. - SHUT OPEN
  - 3. POSITIONER POS. - SHUT STOP
  - 4. POSITIONER POS. - SHUT STOP
  - 5. POSITIONER POS. - SHUT STOP
  - 6. POSITIONER POS. - SHUT STOP
- ECONOMIZER NOTES:** ECONOMIZER SHOULD BE REMOVED ONLY WHEN USING DIFFERENTIAL PRESSURE OR PRESSURE SWITCHES FOR THE TANK. THE TANK SHOULD BE FULLY CHARGED TO THE TANK. THE TANK SHOULD BE FULLY CHARGED TO THE TANK. THE TANK SHOULD BE FULLY CHARGED TO THE TANK.

## 48TC\*\*14 CONTROL WIRING DIAGRAM

YAC CONTROL 208/230V, 460V, 575V  
12.5TON YAC (2)COMPR T1  
10TON YAC (2)COMPR T2

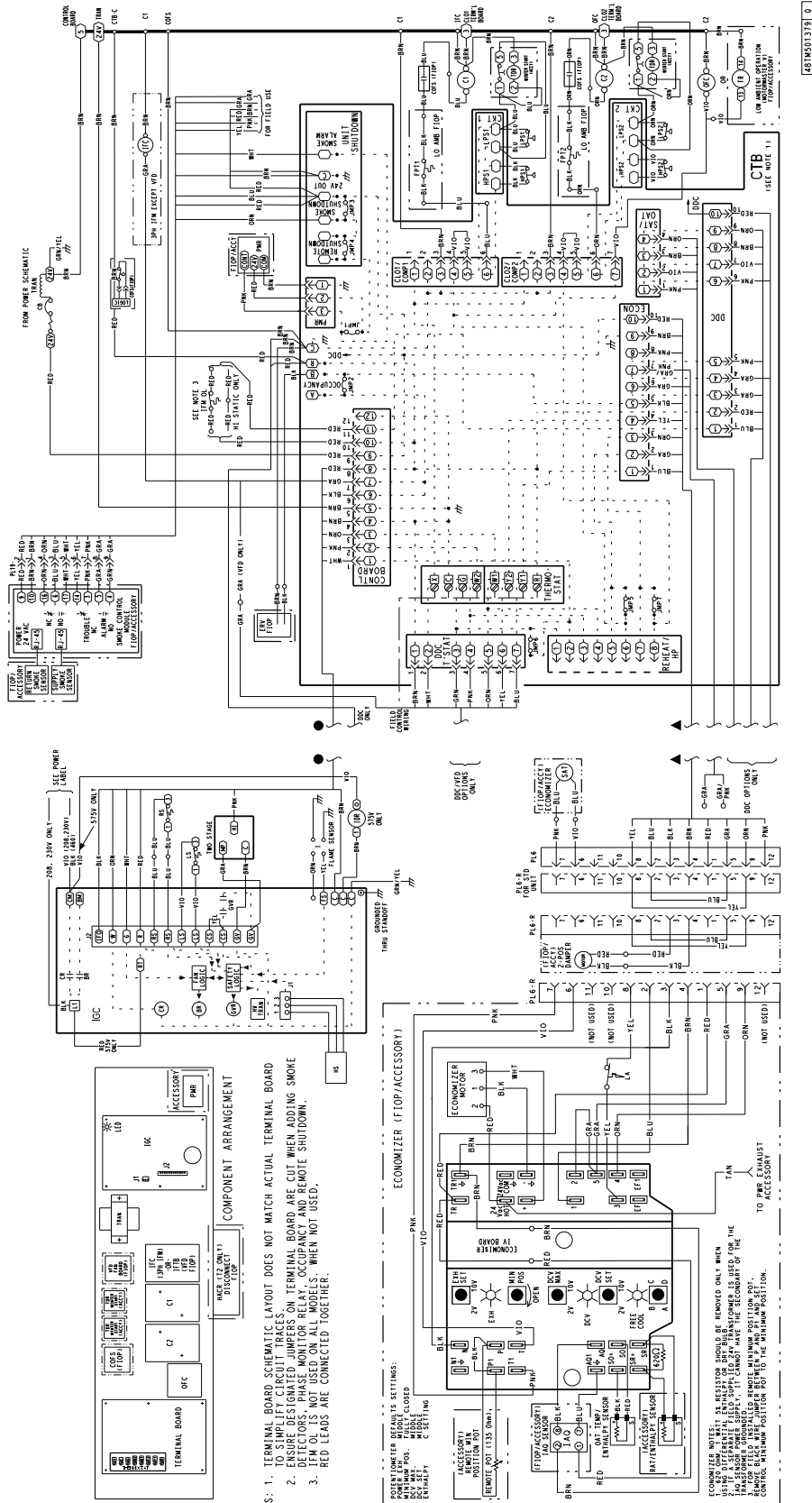

48TC\*\*14 0



## 48TC\*\*07 POWER WIRING DIAGRAM (208/230, 460-3-60)

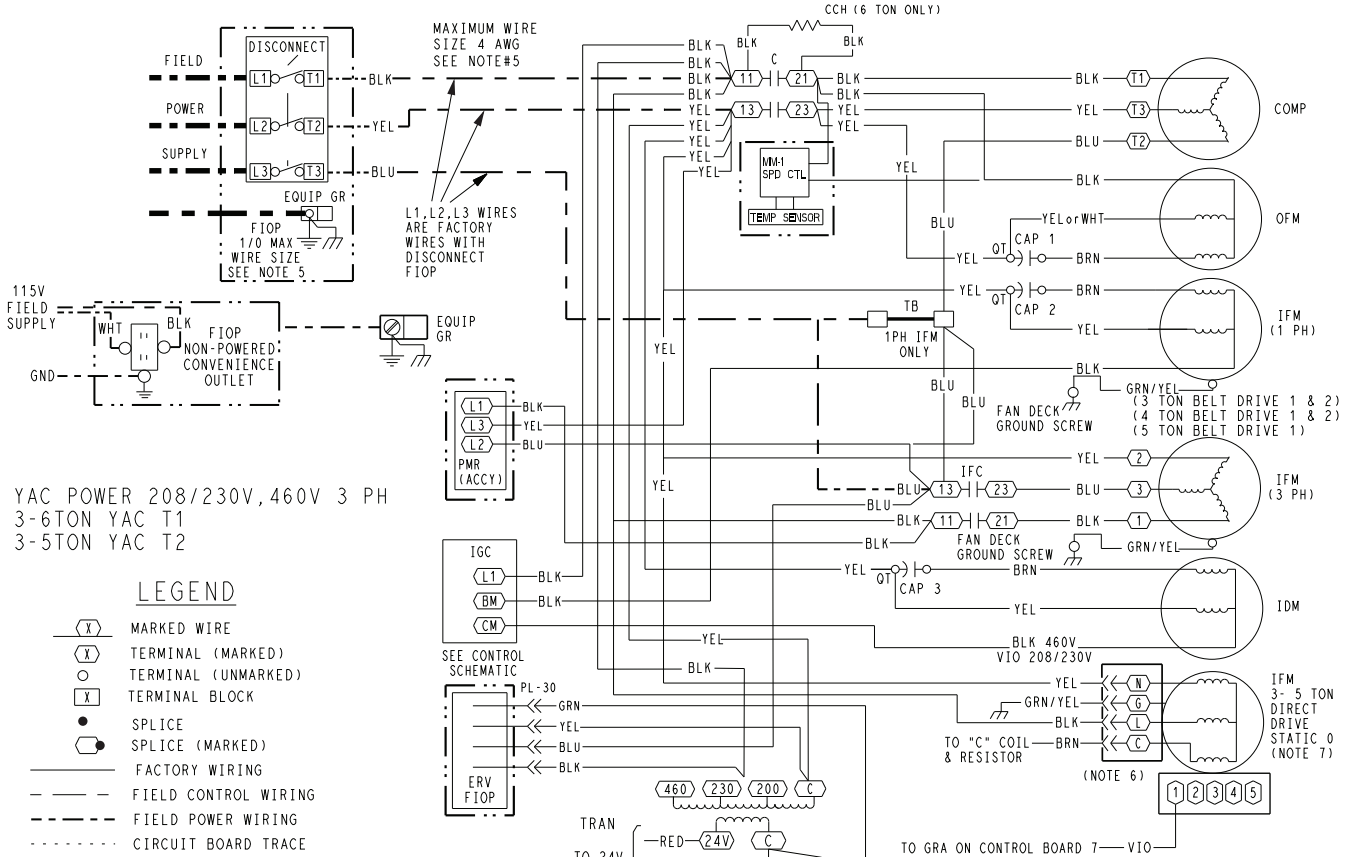

YAC POWER 208/230V, 460V 3 PH  
 3-6TON YAC T1  
 3-5TON YAC T2

### LEGEND

- (X) MARKED WIRE
- (X) TERMINAL (MARKED)
- TERMINAL (UNMARKED)
- (X) TERMINAL BLOCK
- SPLICE
- SPLICE (MARKED)
- FACTORY WIRING
- - - FIELD CONTROL WIRING
- - - FIELD POWER WIRING
- - - CIRCUIT BOARD TRACE
- - - ACCESSORY OR OPTIONAL WIRING
- TO INDICATE COMMON POTENTIAL ONLY: NOT TO REPRESENT WIRING

### NOTES

1. IF ANY OF THE ORIGINAL WIRE FURNISHED MUST BE REPLACED. IT MUST BE REPLACED WITH TYPE 90 C WIRE OR ITS EQUIVALENT.
2. COMPRESSOR AND FAN MOTORS ARE THERMALLY PROTECTED. THREE PHASE MOTORS ARE PROTECTED AGAINST PRIMARY SINGLE PHASING CONDITIONS.
3. 208/230V UNIT TRAN IS WIRED FOR 230V UNIT. IF UNIT IS TO BE RUN WITH 208V POWER SUPPLY DISCONNECT BLK WIRE FROM 230V TAP AND CONNECT TO 200V TAP.
4. USE COPPER, COPPER CLAD ALUMINUM OR ALUMINUM CONDUCTORS.
5. USE COPPER CONDUCTOR ONLY.
6. DONOT DISCONNECT POWER PLUG OR SIGNAL WIRE WHILE UNDER LOAD.
7. FACTORY WIRING FOR SIGNAL CONNECTION: 3-5 TON = 1. RELOCATION OF SIGNAL CONNECTION MAY BE REQUIRED WHEN USING FIELD INSTALLED ACCESSORIES - CONSULT INSTALLATION INSTRUCTION FOR PROPER SELECTION.

- C CONTACTOR, COMPRESSOR
- CAP CAPACITOR
- CB CIRCUIT BREAKER
- CCH CRANKCASE HEATER
- CCN CARRIER COMFORT NETWORK
- CMP SAFE
- COFS COMPRESSOR SAFETY
- COMP COMPRESSOR MOTOR
- CTB CENTRAL TERMINAL BOARD
- DCD DIRECT DIGITAL CONTROL
- ERV ENERGY RECOVERY VENTILATOR
- FIOF FACTORY INSTALLED OPTION
- FSD FIRE SHUT DOWN
- FU FUSE
- GND GROUND
- GVR GAS VALVE RELAY
- HPS HIGH PRESSURE SWITCH
- HS HALL EFFECT SENSOR
- I IGNITOR
- IAQ INDOOR AIR QUALITY SENSORS
- IDM INDUCED DRAFT MOTOR
- IFC INDOOR FAN CONTACTOR
- IFM INDOOR FAN MOTOR

- IGC INTEGRATED GAS CONTROL
- IRH INDOOR RELATIVE HUMIDITY
- LA LOW AMBIENT LOCKOUT
- LOOP PWR CURRENT LOOP POWER
- LPS LOW PRESSURE SWITCH
- LSM LIMIT SWITCH (MANUAL RESET)
- MGV MAIN GAS VALVE
- OAQ OUTDOOR AIR QUALITY
- OAT OUTDOOR AIR TEMP. SEN
- OFM OUTDOOR FAN MOTOR
- OLR OVERLOAD RELAY
- PL PLUG ASSEMBLY
- POT POTENTIOMETER
- PMR PHASE MONITOR RELAY
- QT QUADRUPLE TERMINAL
- R RELAY
- RAT RETURN AIR TEMP. SEN
- RMT OCC REMOTE OCCUPANCY
- RS ROLLOUT SWITCH
- SAT SUPPLY AIR TEMP. SENSOR
- SEN SENSOR
- SET SET POINT OFFSET
- SFS SUPPLY FAN STATUS
- TDR TIME DELAY RELAY(WINTER START)
- TRAN TRANSFORMER

48TM500748 P

### 48TC\*\*08-12 POWER WIRING DIAGRAM (208/230, 460-3-60)

YAC POWER 208/230V, 460V 3 PH  
 7.5-10TON YAC (2)COMPR T1  
 7.5-8.5TON YAC (2)COMPR T2

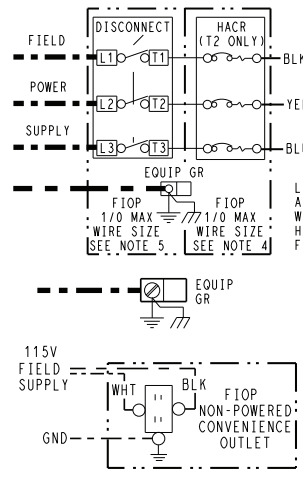
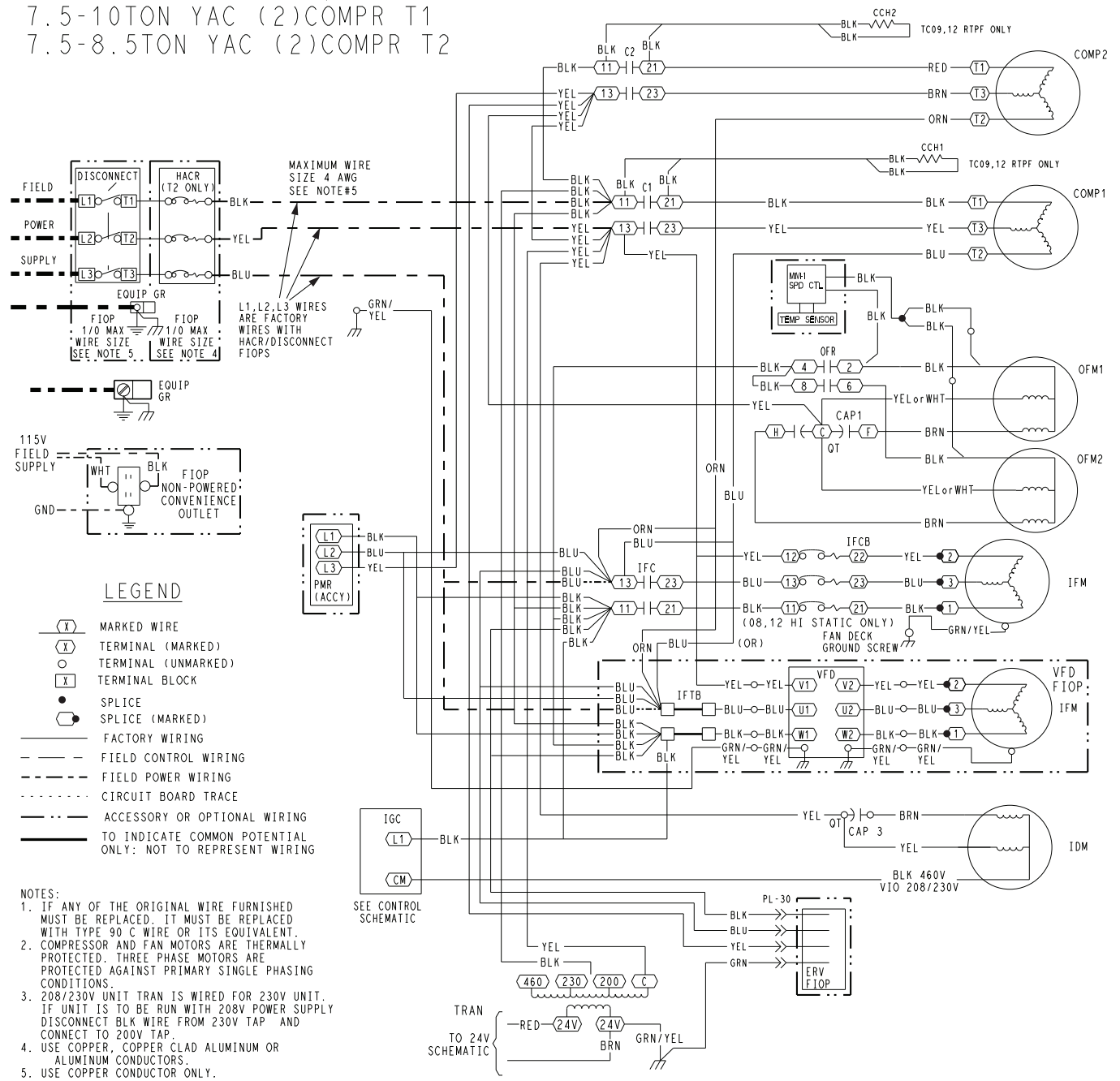

#### LEGEND

- (X) MARKED WIRE
- (X) TERMINAL (MARKED)
- (O) TERMINAL (UNMARKED)
- (X) TERMINAL BLOCK
- SPLICE
- ◐ SPLICE (MARKED)
- FACTORY WIRING
- - - FIELD CONTROL WIRING
- - - FIELD POWER WIRING
- - - - - CIRCUIT BOARD TRACE
- · - · - ACCESSORY OR OPTIONAL WIRING
- · — · — TO INDICATE COMMON POTENTIAL ONLY; NOT TO REPRESENT WIRING

- NOTES:
- IF ANY OF THE ORIGINAL WIRE FURNISHED MUST BE REPLACED, IT MUST BE REPLACED WITH TYPE 90 C WIRE OR ITS EQUIVALENT.
  - COMPRESSOR AND FAN MOTORS ARE THERMALLY PROTECTED. THREE PHASE MOTORS ARE PROTECTED AGAINST PRIMARY SINGLE PHASING CONDITIONS.
  - 208/230V UNIT TRAN IS WIRED FOR 230V UNIT. IF UNIT IS TO BE RUN WITH 208V POWER SUPPLY DISCONNECT BLK WIRE FROM 230V TAP AND CONNECT TO 200V TAP.
  - USE COPPER, COPPER CLAD ALUMINUM OR ALUMINUM CONDUCTORS.
  - USE COPPER CONDUCTOR ONLY.

C	CONTACTOR, COMPRESSOR	I	IGNITOR	OAT	OUTDOOR AIR TEMP. SEN
CAP	CAPACITOR	IAQ	INDOOR AIR QUALITY SENSORS	OFM	OUTDOOR FAN MOTOR
CB	CIRCUIT BREAKER	IDM	INDUCED DRAFT MOTOR	OL	OVERLOAD
CCH	CRANKCASE HEATER	IFC	INDOOR FAN CONTACTOR	PL	PLUG ASSEMBLY
CCN	CARRIER COMFORT NETWORK	IFCB	INDOOR FAN CIRCUIT BREAKER	POT	POTENTIOMETER
CMP SAFE	COMPRESSOR SAFETY	IFTB	INDOOR FAN TERMINAL BLOCK	PMR	PHASE MONITOR RELAY
COFS	CONDENSATE OVERFLOW SWT	IFM	INDOOR FAN MOTOR	QT	QUADRUPLE TERMINAL
COMP	COMPRESSOR MOTOR	IGC	INTEGRATED GAS CONTROL	R	RELAY
CTB	CENTRAL TERMINAL BOARD	IRH	INDOOR RELATIVE HUMIDITY	RAT	RETURN AIR TEMP. SEN
DDC	DIRECT DIGITAL CONTROL	JMP	JUMPER	RMT OCC	REMOTE OCCUPANCY
ERV	ENERGY RECOVERY VENTILATOR	LA	LOW AMBIENT LOCKOUT	RS	ROLLOUT SWITCH
FIOF	FACTORY INSTALLED OPTION	LOOP PWR	LOOP CURRENT POWER	SAT	SUPPLY AIR TEMP. SENSOR
FSD	FIRE SHUT DOWN	LPS	LOW PRESSURE SWITCH	SEN	SENSOR
FS	FLAME SENSOR	LSM	LIMIT SWITCH (MANUAL RESET)	SET	SET POINT OFFSET
FU	FUSE	LS	LIMIT SWITCH	SFS	SUPPLY FAN STATUS
GND	GROUND	MGV	MAIN GAS VALVE	TDR	TIME DELAY RELAY(WINTER START)
GVR	GAS VALVE RELAY	OAO	OUTDOOR AIR QUALITY	TRAN	TRANSFORMER
HPS	HIGH PRESSURE SWITCH			VFD	VARIABLE FREQUENCY DRIVE
HS	HALL EFFECT SENSOR				

## 48TC\*M08 POWER WIRING DIAGRAM (575-3-60)

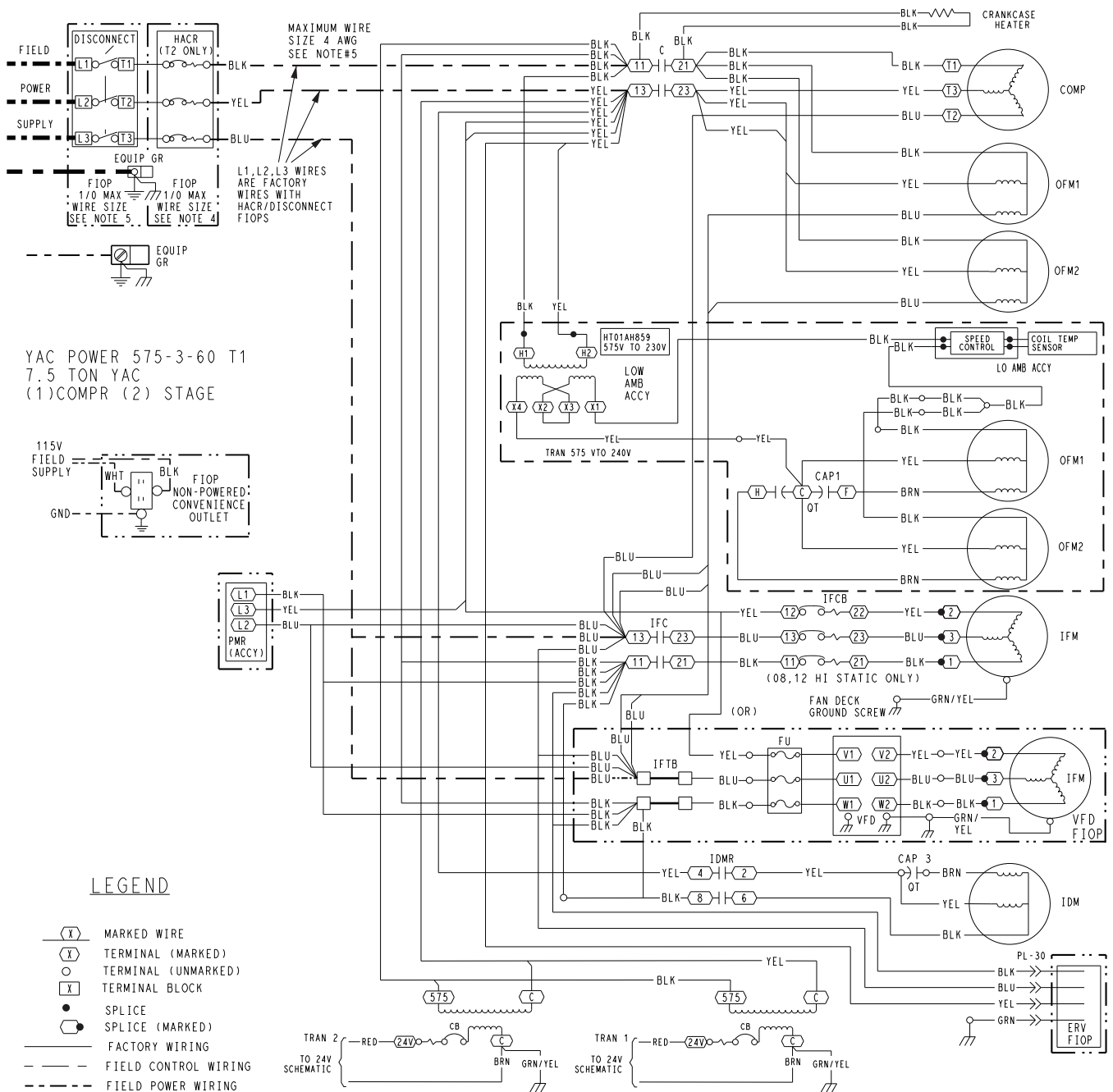

YAC POWER 575-3-60 T1  
7.5 TON YAC  
(1) COMP (2) STAGE

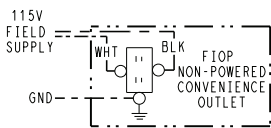

### LEGEND

- (X) MARKED WIRE
- (X) TERMINAL (MARKED)
- TERMINAL (UNMARKED)
- [X] TERMINAL BLOCK
- SPLICE
- SPLICE (MARKED)
- FACTORY WIRING
- - - FIELD CONTROL WIRING
- - - FIELD POWER WIRING
- - - - - CIRCUIT BOARD TRACE
- - - - - ACCESSORY OR OPTIONAL WIRING
- TO INDICATE COMMON POTENTIAL ONLY; NOT TO REPRESENT WIRING

### NOTES:

1. IF ANY OF THE ORIGINAL WIRE FURNISHED MUST BE REPLACED, IT MUST BE REPLACED WITH TYPE 90 C WIRE OR ITS EQUIVALENT.
2. COMPRESSOR AND FAN MOTORS ARE THERMALLY PROTECTED. THREE PHASE MOTORS ARE PROTECTED AGAINST PRIMARY SINGLE PHASING CONDITIONS.
3. TRAN IS WIRED FOR 575V UNIT.
4. USE COPPER, COPPER CLAD ALUMINUM OR ALUMINUM CONDUCTORS.
5. USE COPPER CONDUCTOR ONLY.

C	CONTACTOR, COMPRESSOR	IGC	INTEGRATED GAS CONTROL
CAP	CAPACITOR	IRH	INDOOR RELATIVE HUMIDITY
CB	CIRCUIT BREAKER	LA	LOW AMBIENT LOCKOUT
CH	CRANKCASE HEATER	LDR	COMPRESSOR LOADER (INTERNAL)
CCN	CARRIER COMFORT NETWORK	LO AMB	LOW AMBIENT CONTROL
CMP SAFE	COMPRESSOR SAFETY	LPS	LOW PRESSURE SWITCH
COFS	CONDENSATE OVERFLOW SWT	LSM	LIMIT SWITCH (MANUAL RESET)
COMP	COMPRESSOR MOTOR	MGV	MAIN GAS VALVE
CS2V	COOLING STAGE-2 VALVE	OAO	OUTDOOR AIR QUALITY
CTB	CENTRAL TERMINAL BOARD	OAT	OUTDOOR AIR TEMP. SEN
DDC	DIRECT DIGITAL CONTROL	OFM	OUTDOOR FAN MOTOR
ERV	ENERGY RECOVERY VENTILATOR	OL	OVERLOAD
FIOF	FACTORY INSTALLED OPTION	PL	PLUG ASSEMBLY
FSD	FIRE SHUT DOWN	POT	POTENTIOMETER
FUSE	FUSE	PMR	PHASE MONITOR RELAY
GND	GROUND	QT	QUADRUPLE TERMINAL
GVR	GAS VALVE RELAY	R	RELAY
HPS	HIGH PRESSURE SWITCH	RAT	RETURN AIR TEMP. SEN
HS	HALL EFFECT SENSOR	RS	ROLLOUT SWITCH
IGN	IGNITOR	SAT	SUPPLY AIR TEMP. SENSOR
IAO	INDOOR AIR QUALITY SENSORS	SEN	SENSOR
IDMR	INDUCED DRAFT MOTOR RELAY	SET	SET POINT OFFSET
IFC	INDOOR FAN CONTACTOR	SFS	SUPPLY FAN STATUS
IFCB	INDOOR FAN CIRCUIT BREAKER	TDR	TIME DELAY RELAY(WINTER START)
IFTB	INDOOR FAN TERMINAL BLOCK	TRAN	TRANSFORMER
IFM	INDOOR FAN MOTOR		

### 48TC\*\*14 POWER WIRING DIAGRAM (208/230, 460-3-60)

YAC POWER 208/230V, 460V 3 PH  
 12.5TON YAC (2)COMPR T1  
 10TON YAC (2)COMPR T2

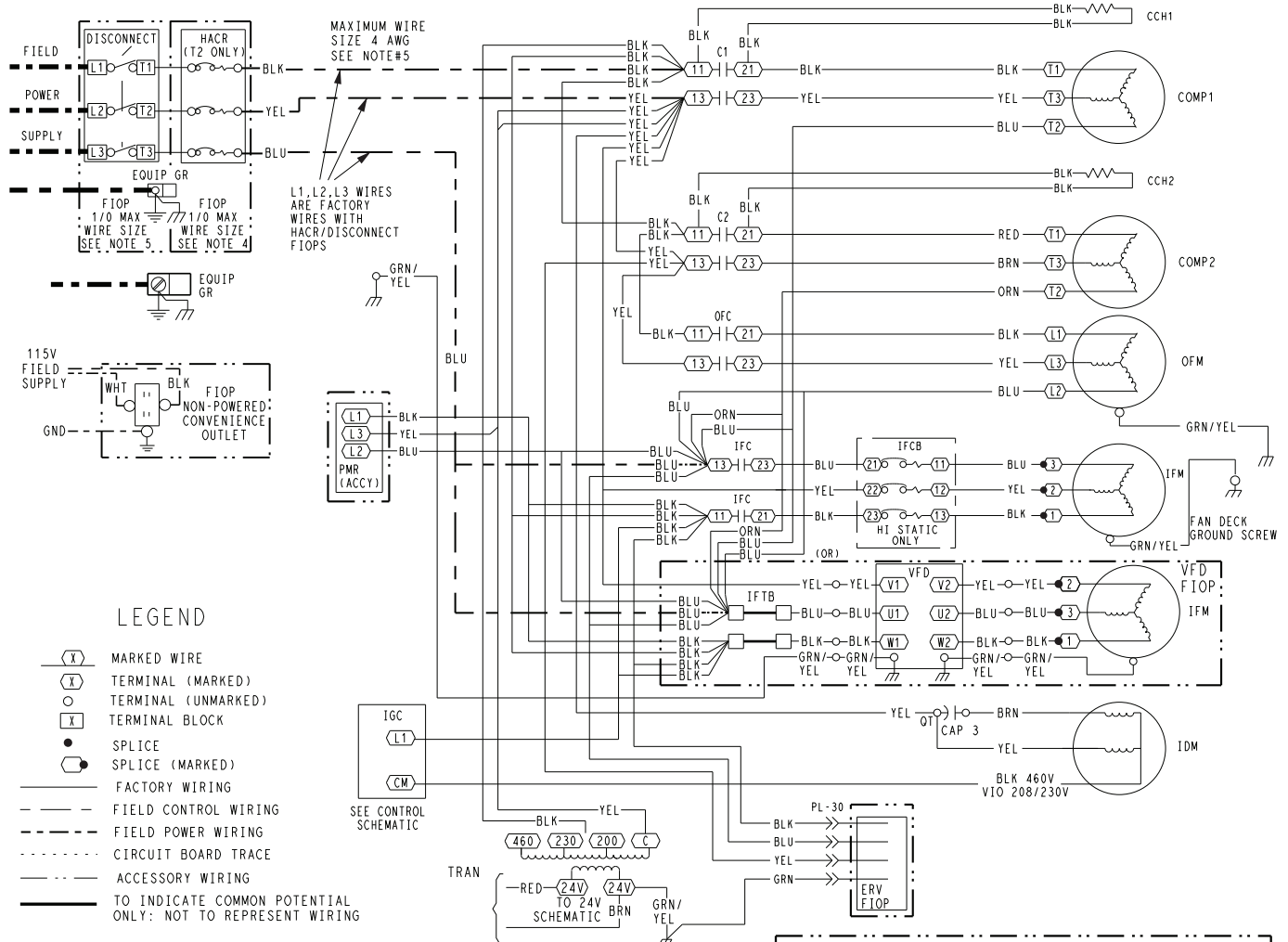

#### LEGEND

- (X) MARKED WIRE
- (X) TERMINAL (MARKED)
- (O) TERMINAL (UNMARKED)
- (X) TERMINAL BLOCK
- SPLICE
- ◻ SPLICE (MARKED)
- FACTORY WIRING
- - - FIELD CONTROL WIRING
- - - FIELD POWER WIRING
- - - CIRCUIT BOARD TRACE
- - - ACCESSORY WIRING
- TO INDICATE COMMON POTENTIAL ONLY: NOT TO REPRESENT WIRING

- C CONTACTOR, COMPRESSOR
- CAP CAPACITOR
- CB CRANKCASE HEATER
- CCH CARRIER COMFORT NETWORK
- CCN COMPRESSOR SAFETY
- CMF CONDENSATE OVERFLOW SWT
- COFS COMPRESSOR MOTOR
- CTB CENTRAL TERMINAL BOARD
- DDC DIRECT DIGITAL CONTROL
- ERV ENERGY RECOVERY VENTILATOR
- FR FAN RELAY
- FIOP FAN INSTALLED OPTION
- FS FAN SHUT DOWN
- FSD FUSE
- FU GROUND
- GND GROUND
- GVR GAS VALVE RELAY
- HPS HIGH PRESSURE SWITCH
- HS HALL EFFECT SENSOR
- I IGNITOR
- IAO INDOOR AIR QUALITY SENSORS
- IDM INDUCED DRAFT MOTOR
- IFR INDUCED DRAFT RELAY
- IFC INDOOR FAN CONTACTOR
- IFCB INDOOR FAN CIRCUIT BREAKER
- IFM INDOOR FAN MOTOR
- IFTB INDOOR FAN TERMINAL BLOCK
- IGC INTEGRATED GAS CONTROL
- IRH INDOOR RELATIVE HUMIDITY
- LA LOW AMBIENT LOCKOUT
- LOOP PWR CURRENT LOOP POWER
- LPS LOW PRESSURE SWITCH
- LSM LIMIT SWITCH (MANUAL RESET)

#### NOTES:

1. IF ANY OF THE ORIGINAL WIRE FURNISHED MUST BE REPLACED; IT MUST BE REPLACED WITH TYPE 90 C WIRE OR ITS EQUIVALENT.
2. COMPRESSOR AND FAN MOTORS ARE THERMALLY PROTECTED. THREE PHASE MOTORS ARE PROTECTED AGAINST PRIMARY SINGLE PHASING CONDITIONS.
3. 208/230V UNIT TRAN IS WIRED FOR 230V UNIT. IF UNIT IS TO BE RUN WITH 208V POWER SUPPLY DISCONNECT BLK WIRE FROM 230V TAP AND CONNECT TO 200V TAP.
4. USE COPPER, COPPER CLAD ALUMINUM OR ALUMINUM CONDUCTORS.
5. USE COPPER CONDUCTOR ONLY.
6. PIN NO'S 4, 5 & 6 ARE FOR 460/575V. FOR 208/230V PINS 1, 2 & 3 ARE USED RESPECTIVELY.

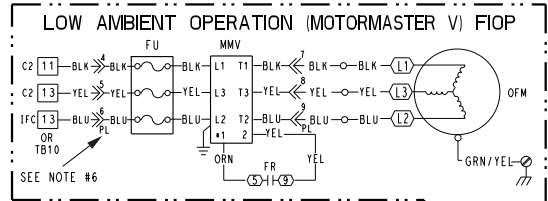

- MGV MAIN GAS VALVE
- OAQ OUTDOOR AIR QUALITY
- OAT OUTDOOR AIR TEMP. SEN
- OFM OUTDOOR FAN MOTOR
- OL OVERLOAD
- PL PLUG ASSEMBLY
- POT POTENTIOMETER
- PMR PHASE MONITOR RELAY
- QUADRUPL TERMINAL
- R RELAY
- RAT RETURN AIR TEMP. SEN
- RMT OCC REMOTE OCCUPANCY
- RS ROLLOUT SWITCH
- SAT SUPPLY AIR TEMP. SENSOR
- SEN SENSOR
- SET SET POINT OFFSET
- SFS SUPPLY FAN STATUS
- TDR TIME DELAY RELAY(WINTER START)
- TRAN TRANSFORMER
- VFD VARIABLE FREQUENCY DRIVE



# Typical wiring diagrams (cont)



## 48TC\*\*16 POWER WIRING DIAGRAM (208/230, 460-3-60)

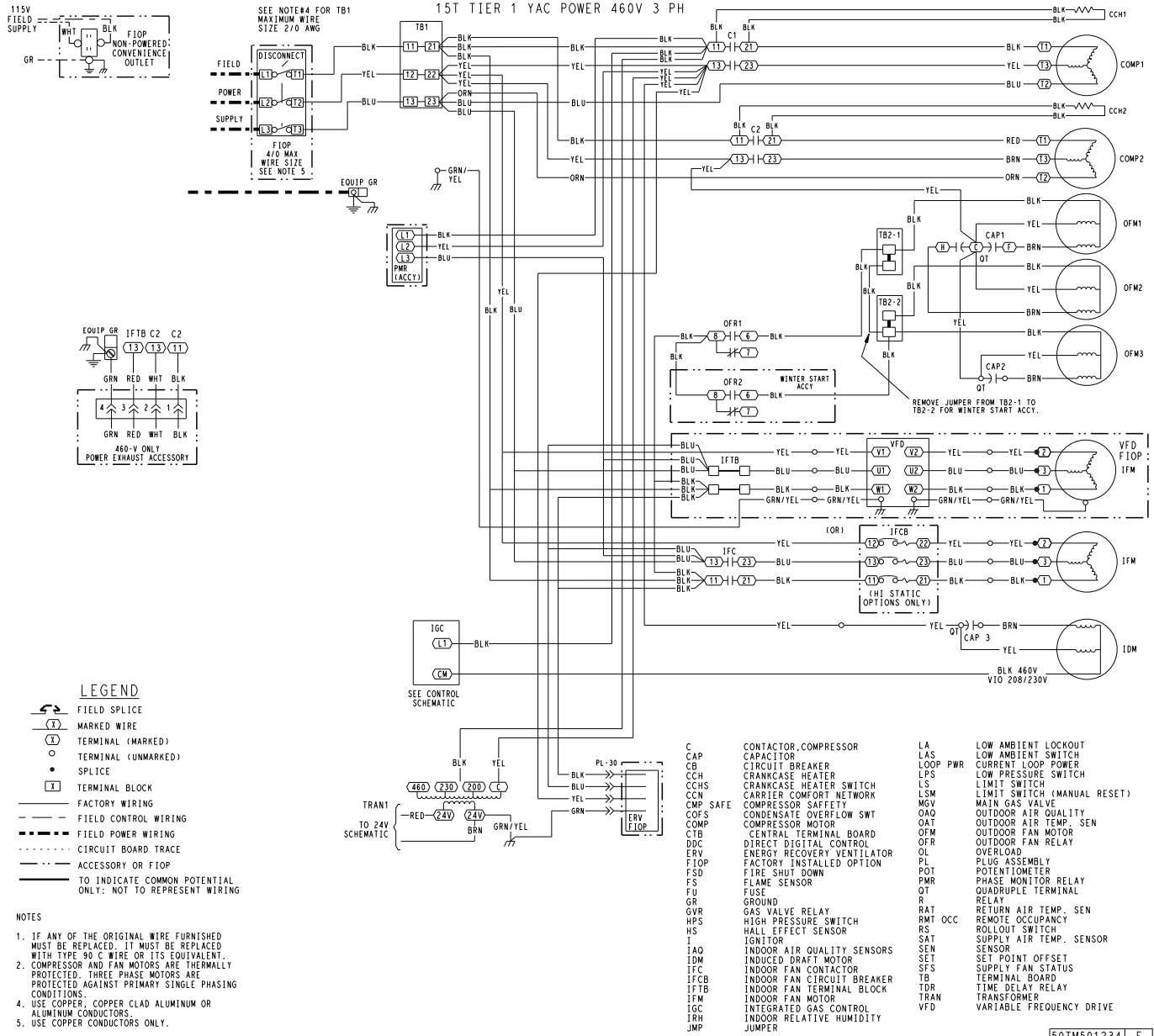

50TM501234 E



## General

The sequence below describes the sequence of operation for an electro-mechanical unit with and without a factory-installed EconoMi\$er® IV and X (called “economizer” in this sequence). For information regarding a direct digital controller, see the start-up, operations, and troubleshooting manual for the applicable controller.

## Electro-mechanical units with no economizer

### Cooling (single speed indoor fan motor)

When the thermostat calls for cooling, terminals G and Y1 are energized. As a result, the indoor fan contactor (IFC) and the compressor contactor (C1) are energized, causing the indoor fan motor (IFM), compressor #1, and outdoor fan to start. If the unit has 2 stages of cooling, the thermostat will additionally energize Y2. The Y2 signal will energize compressor contactor #2 (C2), causing compressor #2 to start. Regardless of the number of stages, the outdoor fan motor runs continuously while unit is cooling. When SAV™ system is utilized, indoor fan motor runs at design CFM (full speed) during the heating operation. On 1-circuit/2-stage cooling model from 7.5 to 10 ton, the SAV 2-speed fan motor system is not available. Efficiencies to meet the U.S. Department of Energy - 2018 IEER efficiency rating are achieved by using a precision 2-stage compressor operation sequencing with one indoor fan motor speed.

### Cooling (2-speed indoor fan motor)

Per ASHRAE 90.1-2016 standard, during the first stage of cooling operation the SAV 2-speed indoor fan motor system will adjust the fan motor to provide 66% of the total cfm established for the unit. When a call for the second stage of cooling is required, the 2-speed fan motor system will allow the total cfm for the unit established (100%). This is standard on all U.S. installed models with 2 circuit/2 stage cooling, to meet U.S. Department of Energy - 2018 IEER efficiency rating.

Carrier's Staged Air Volume (SAV) 2-speed indoor fan motor system automatically adjusts the indoor fan motor speed in sequence with the units cooling operation. Per ASHRAE 90.1-2016 standard, during the first stage of cooling operation, the 2-speed controller will adjust the fan motor to provide 66% of the total cfm established for the unit. When a call for the second stage of cooling is required, the 2-speed fan motor controller will allow the total cfm for the unit established (100%). During the heating mode, the 2-speed fan controller will allow total design cfm (100%) operation and during the ventilation mode, will allow operation to 66% of total cfm.

### Heating (Single or 2-speed indoor fan motor)

NOTE: WeatherMaker® units have either 1 or 2 stages of gas heat. When SAV system is utilized, indoor fan motor runs at design cfm (full speed) during the heating operation.

When the thermostat calls for heating, power is sent to W on the Integrated Gas Controller (IGC) board. An LED (light-emitting diode) on the IGC board turns on and remains on during normal operation. A check is made to ensure that the rollout switch and limit switch are closed.

If the check was successful, the induced-draft motor is energized, and when its speed is satisfactory, as proven by the “hall effect” sensor, the ignition activation period begins. The burners will ignite within 5 seconds. If the burners do not light, there is a 22 second delay before another 5-second attempt. This sequence is repeated for 15 minutes or until the burners light. If, after the 15 minutes, the burners still have not lit, heating is locked out. To reset the control, break 24-v power to the thermostat.

When ignition occurs, the IGC board will continue to monitor the condition of the rollout switch, the limit switches, the “hall effect” sensor, as well as the flame sensor. 45 seconds after ignition occurs, assuming the unit is controlled through a room thermostat set for fan auto, the indoor fan motor will energize (and the outdoor air dampers will open to their minimum position). If, for some reason, the over-temperature limit opens prior to the start of the indoor fan blower, the unit will shorten the 45 second delay to 5 seconds less than the time from initiation of heat to when the limit tripped. Gas will not be interrupted to the burners and heating will continue. Once the fan-on delay has been modified, it will not change back to 45 seconds until power is reset to the control.

On units with 2 stages of heat, when additional heat is required, W2 closes and initiates power to the second stage of the main gas valve. When the thermostat is satisfied, W1 and W2 open and the gas valve closes, interrupting the flow of gas to the main burners.

If the call for W1 lasted less than 1 minute, the heating cycle will not terminate until 1 minute after W1 became active. If the unit is controlled through a room thermostat set for fan auto, the indoor fan motor will continue to operate for an additional 45 seconds then stop. If the over-temperature limit opens after the indoor motor is stopped, but within 10 minutes of W1 becoming inactive, on the next cycle the time will be extended by 15 seconds. The maximum delay is 3 minutes. Once modified, the fan off delay will not change back to 45 seconds unless power is reset to the control. A LED indicator is provided on the IGC to monitor operation.

## Electro-mechanical units with an economizer

### Cooling

When free cooling is not available, the compressors will be controlled by the zone thermostat. When free cooling is available, the outdoor-air damper is modulated by the EconoMi\$er IV and X control to provide a 50°F (10°C) to 55°F (13°C) mixed-air temperature into the zone. As the mixed air temperature fluctuates above 55°F (13°C) or below 50°F (10°C) dampers will be modulated (open or close) to bring the mixed-air temperature back within control. If mechanical cooling is utilized with free cooling, the outdoor-air damper will maintain its current position at the time the compressor is started. If the increase in cooling capacity causes the mixed-air temperature to drop below 45°F (7°C), then the outdoor-air damper position will be decreased to the minimum position. If the mixed-air temperature continues to fall, the outdoor-air damper will close. Control returns to normal once the mixed-air temperature rises above 48°F (9°C). The power exhaust fans

will be energized and de-energized, if installed, as the outdoor-air damper opens and closes.

If field-installed accessory CO<sub>2</sub> sensors are connected to the EconoMi\$er® IV and X control, a demand controlled ventilation strategy will begin to operate. As the CO<sub>2</sub> level in the zone increases above the CO<sub>2</sub> setpoint, the minimum position of the damper will be increased proportionally. As the CO<sub>2</sub> level decreases because of the increase in fresh air, the outdoor-air damper will be proportionally closed. For EconoMi\$er IV and X operation, there must be a thermostat call for the fan (G). If the unit is occupied and the fan is on, the damper will operate at minimum position. Otherwise, the damper will be closed.

When the EconoMi\$er IV and X control is in the occupied mode and a call for cooling exists (Y1 on the thermostat), the control will first check for indoor fan operation. If the fan is not on, then cooling will not be activated. If the fan is on, then the control will open the EconoMi\$er IV and X damper to the minimum position.

When the EconoMi\$er IV and X control is in the occupied mode and a call for cooling exists (Y1 on the thermostat), the control will first check for indoor fan operation. If the fan is not on, then cooling will not be activated. If the fan is on, then the control will open the EconoMi\$er IV and X damper to the minimum position.

On the initial power to the EconoMi\$er IV and X control, it will take the damper up to 2<sup>1</sup>/<sub>2</sub> minutes before it begins to position itself. After the initial power-up, further changes in damper position can take up to 30 seconds to initiate. Damper movement from full closed to full open (or vice versa) will take between 1<sup>1</sup>/<sub>2</sub> and 2<sup>1</sup>/<sub>2</sub> minutes. If free cooling can be used as determined from the appropriate changeover command (switch, dry bulb, enthalpy curve, differential dry bulb, or differential enthalpy), then the control will modulate the dampers open to maintain the mixed air temperature setpoint at 50°F (10°C) to 55°F (13°C). If there is a further demand for cooling (cooling second stage - Y2 is energized), then the control will bring on compressor stage 1 to maintain the mixed

air temperature setpoint. The EconoMi\$er IV and X damper will be open at maximum position.

2-Speed NOTE: When operating in ventilation mode only, the indoor fan motor will automatically adjust to two-thirds of the total cfm established.

## Heating

The sequence of operation for the heating is the same as an electro-mechanical unit with no economizer. The only difference is how the economizer acts. The economizer will stay at the Economizer Minimum Position while the evaporator fan is operating. The outdoor-air damper is closed when the indoor fan is not operating. Refer to Service and Maintenance Manual for further details.

## Optional Humidi-MiZer® dehumidification system

Units with the factory equipped Humidi-MiZer® option are capable of providing multiple modes of improved dehumidification as a variation of the normal cooling cycle. The Humidi-MiZer option includes additional valves in the liquid line and discharge line of each refrigerant circuit, a small reheat condenser coil downstream of the evaporator, and Motormaster® variable-speed control of some or all outdoor fans. Operation of the revised refrigerant circuit for each mode is described below.

The Humidi-MiZer system provides three sub-modes of operation: Cool, Reheat1, and Reheat2.

- Cool mode - provides a normal ratio of Sensible and Latent Cooling effect from the evaporator coil.
- Reheat1 - provides increased Latent Cooling while slightly reducing the Sensible Cooling effect.
- Reheat2 - provides normal Latent Cooling but with null or minimum Sensible Cooling effect delivered to the space.

The Reheat1 and Reheat2 modes are a variable when the unit is not in a Heating mode and when the Low Ambient Lockout switch is closed.

The following diagrams depict piping for Single Stage cooling units.

**NORMAL COOLING MODE — HUMIDI-MIZER® SYSTEM**

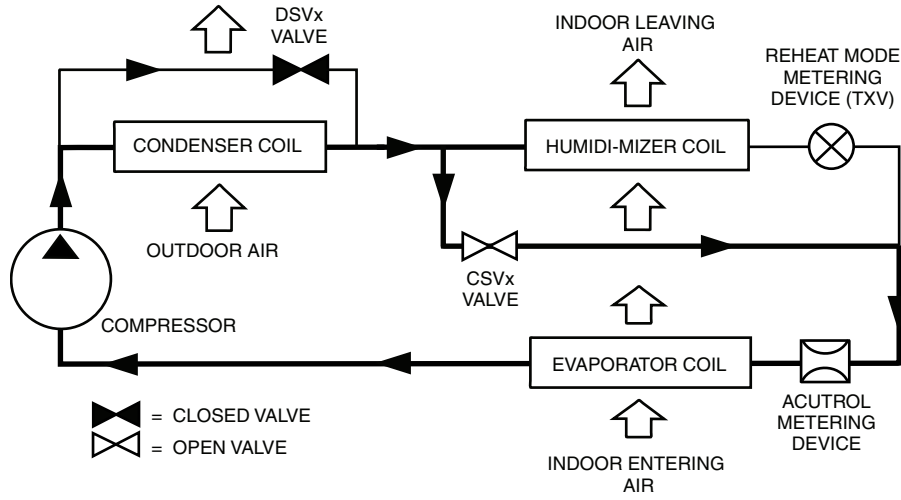

**SUBCOOLING MODE (REHEAT 1) — HUMIDI-MIZER SYSTEM**

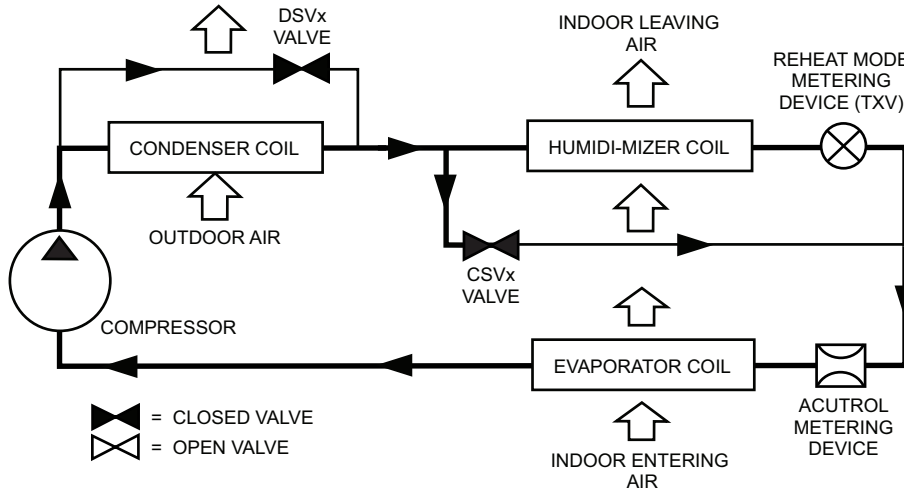

**SUBCOOLING MODE (REHEAT 2) — HUMIDI-MIZER SYSTEM**

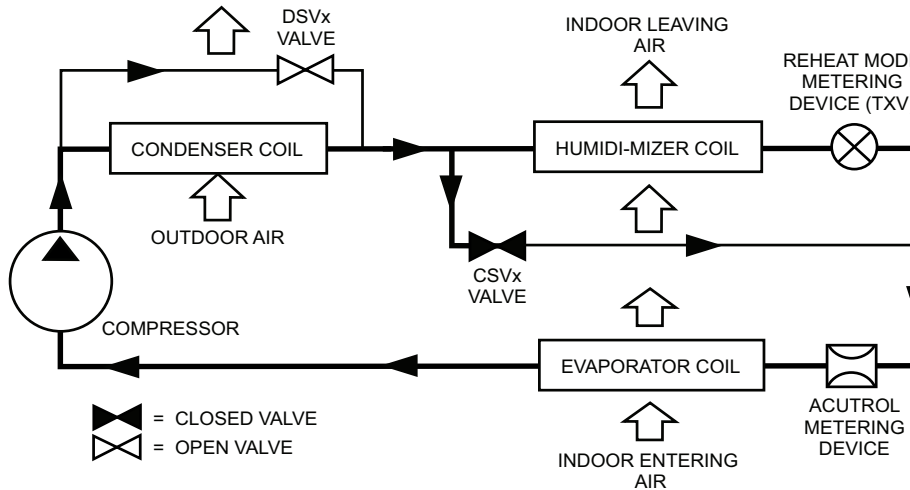

## Min operating ambient temp (cooling)

In mechanical cooling mode, your Carrier rooftop unit can safely operate down to an outdoor ambient temperature of 40°F (4°C) and 25°F (-4°C), with an accessory winter start kit. It is possible to provide cooling at lower outdoor ambient temperatures by using less outside air, economizers, and/or accessory low ambient kits.

## Max operating ambient temp (cooling)

The maximum operating ambient temperature for cooling mode is 115°F (46°C). While cooling operation above 115°F (46°C) may be possible, it could cause either a reduction in performance, reliability, or a protective action by the unit's internal safety devices.

## Min mixed air temp (heating)

Using the factory settings, the minimum temperatures for the mixed air (the combined temperature of the warm return air and the cold outdoor air) entering the dimpled, gas heat exchangers are:

<u>Aluminized</u>	<u>Stainless Steel</u>
50°F (10°C) continuous	40°F (4°C) continuous
45°F (7°C) intermittent	35°F (2°C) intermittent

Operating at lower mixed-air temperatures may be possible, if a field-supplied, outdoor air thermostat initiates both heat stages when the temperature is less than the minimum temperatures listed above. Please contact your local Carrier representative for assistance.

## Min and max airflow (heating and cooling)

To maintain safe and reliable operation of your rooftop, operate within the heating airflow limits during heating mode and cooling airflow limits during cooling mode. Operating above the max may cause blow-off, undesired airflow noise, or airflow related problems with the rooftop unit. Operating below the min may cause problems with coil freeze-up and unsafe heating operation. Heating and cooling limitations differ when evaluating operating cfm. The minimum value is the HIGHER of the cooling and heating minimum cfm values published on page 6, and the maximum value is the LOWER of the cooling and heating maximum values published on page 6.

## Heating-to-cooling changeover

Your unit will automatically change from heating to cooling mode when using a thermostat with an auto-change-over feature.

## Airflow

All units are draw-through in cooling mode and blow-through in heating mode.

## Outdoor air application strategies

Economizers reduce operating expenses and compressor run time by providing a free source of cooling and a means of ventilation to match application changing needs. In fact, they should be considered for most applications. Also, consider the various economizer control methods and their benefits, as well as sensors required to accomplish your application goals. Please contact your local Carrier representative for assistance.

## Motor limits, break horsepower (BHP)

Due to internal design of Carrier units, the air path, and specially designed motors, the full horsepower (maximum continuous BHP) band, as listed in Physical Data Table Cooling, can be used with the utmost confidence. There is no need for extra safety factors, as Carrier motors are designed and rigorously tested to use the entire, listed BHP range without either nuisance tripping or premature motor failure.

## Propane heating

Propane has different physical qualities than natural gas. As a result, propane requires different fuel to air mixture. To optimize the fuel/air mixture for propane, Carrier sells different burner orifices in an easy to install accessory kit. To select the correct burner orifices or determine the heat capacity for a propane application, use either the selection software, or the unit's service manual.

## High altitude heating

High altitudes have less oxygen, which affects the fuel/air mixture in heat exchangers. In order to maintain a proper fuel/air mixture, heat exchangers operating in altitudes above 2000 ft (610 m) require different orifices. To select the correct burner orifices or determine the heat capacity for a high altitude application, use either the selection software, or the unit's service manual.

High altitudes have less oxygen, which means heat exchangers need less fuel. The new gas orifices in this field-installed kit make the necessary adjustment for high altitude applications. They significantly improve fuel to air mixture and maintain healthy combustion on altitudes above 2000 ft (610 m).

NOTE: Typical natural gas heating value ranges from 975 to 1050 Btu/ft<sup>3</sup> at sea level nationally. The heating value goes down approximately 1.7% per every thousand feet elevation. Standard factory orifices can typically be used up to 2000 ft (610 m) to 4500 ft (1372 m) elevation without any operational issues.

## Sizing a rooftop

Bigger isn't necessarily better. While an air conditioner needs to have enough capacity to meet the design loads, it doesn't need excess capacity. In fact, excess capacity typically results in very poor part load performance and humidity control.

Using higher design temperatures than ASHRAE recommends for your location, adding "safety factors" to the calculated load, are all signs of oversizing air conditioners. Oversizing the air conditioner leads to poor humidity control, reduced efficiency, higher utility bills, larger indoor temperature swings, excessive noise, and increased wear and tear on the air conditioner.

Rather than oversizing an air conditioner, engineers should "right-size" or even slightly undersize air conditioners. Correctly sizing an air conditioner controls humidity better; promotes efficiency; reduces utility bills; extends equipment life, and maintains even, comfortable temperatures. Please contact your local Carrier representative for assistance.

## Low ambient applications

The optional Carrier economizer can adequately cool your space by bringing in fresh, cool outside air. In fact, when so equipped, accessory low-ambient kit may not be necessary. In low ambient conditions, unless the outdoor air is excessively humid or contaminated, economizer-based “free cooling” is the preferred less costly and energy conscious method. In low ambient applications where outside air might not be desired (such as contaminated or excessively humid outdoor environments), your Carrier rooftop can operate to ambient temperatures down to -20°F (-29°C) using the recommended accessory Motormaster® low ambient controller or down to 25°F (-4°C) with the field-installed Winter Start Package.

### Winter Start

Carrier's winter start kit extends the low ambient limit of your rooftop to 25°F (-4°C). The kit bypasses the low pressure switch, preventing nuisance tripping of the low pressure switch. Other low ambient precautions may still be prudent.

### Staged air volume (SAV™) 2-speed indoor fan motor system

Carrier's SAV system has soft start capabilities to slowly ramp up the fan speeds, thus eliminating any high inrush air volume during initial start-up. It also has internal over current protection for the fan motor and a field-installed display kit that allows adjustment and in depth diagnostics if required.

The SAV 2-speed fan motor system is factory preprogrammed and tested and requires no field adjustment to set up. The unit fan performance static pressure and cfm can be easily adjusted using the traditional means of belt drive pulley adjustments.

This SAV system is available on models with 2-circuit/2-stage cooling (08-16 sizes) and 1-circuit/1-stage cooling (07 size) operation with electro-mechanical or RTU Open (multi Protocol) controls. Both space sensor and conventional thermostats controls can be used to provide accurate control in any application.

When used with the SAV system, the damper will either over-ventilate or under-ventilate during certain modes of operation. Be aware the effects that ventilation rate has on leaving air temperatures. This becomes more noticeable in extreme temperatures (heating and cooling), since the unit is now treating a higher volume of outdoor air. In these scenarios, there are greater advantages of using an EconoMi\$er® X, EconoMi\$er 2, or 3-Position Damper.

### Application/selection option

Selection software by Carrier saves time by performing many of the steps above. Contact your Carrier sales representative for assistance.

## 48TC STAGED AIR VOLUME (SAV™) - VARIABLE FREQUENCY DRIVE (VFD) HP RATING

MODEL SIZE	STATIC OPTION	VOLTAGE	VFD HP
07	STD	208/230	3.0
		460	3.0
		575	3.0
	MED	208/230	3.0
		460	3.0
		575	5.0
	HIGH	208/230	3.0
		460	5.0
		575	5.0
08	STD	208/230	3.0
		460	3.0
		575	3.0
	MED	208/230	3.0
		460	3.0
		575	5.0
	HIGH	208/230	7.5
		460	7.5
		575	7.5
09	STD	208/230	3.0
		460	3.0
		575	3.0
	MED	208/230	3.0
		460	3.0
		575	3.0
	HIGH	208/230	5.0
		460	5.0
		575	5.0
12	STD	208/230	3.0
		460	3.0
		575	3.0
	MED	208/230	5.0
		460	5.0
		575	5.0
	HIGH	208/230	7.5
		460	7.5
		575	7.5
14	STD	208/230	3.0
		460	3.0
		575	5.0
	MED	208/230	5.0
		460	5.0
		575	5.0
	HIGH	208/230	7.5
		460	7.5
		575	7.5
16	STD	208/230	3.0
		460	3.0
		575	5.0
	MED	208/230	5.0
		460	5.0
		575	5.0
	HIGH	208/230	7.5
		460	7.5
		575	7.5



Note about this specification: These specifications are written in “Masterformat” as published by the Construction Specification Institute. Please feel free to copy this specification directly into your building spec.

**WeatherMaker®**

## **Gas heat/electric cooling packaged rooftop HVAC guide specifications**

Size range: **6 to 15 Nominal Tons**

Carrier Model Number: **48TC**

### **Part 1 — (23 06 80) Schedules for decentralized HVAC equipment**

1.01 (23 06 80.13) Decentralized Unitary HVAC Equipment Schedule

- A. (23 06 80.13.A.) Rooftop unit (RTU) schedule
1. Schedule is per the project specification requirements.

### **Part 2 — (23 07 16) HVAC equipment insulation**

2.01 (23 07 16.13) Decentralized, Rooftop Units:

- A. (23 07 16.13.A.) Evaporator fan compartment:
1. Interior cabinet surfaces shall be insulated with a minimum 1/2-in. thick, minimum 1 1/2-lb density, flexible fiberglass insulation bonded with a phenolic binder, neoprene coated on the air side.
  2. Insulation and adhesive shall meet NFPA 90A requirements for flame spread and smoke generation.
  3. Unit internal insulation linings shall be resistant to mold growth in accordance with “mold growth and humidity” test in ASTM C1338, G21, and UL 181 or comparable test method. Air stream surfaces shall be evaluated in accordance with the “Erosion Test” in UL 181, as part of ASTM C1071.
- B. (23 07 16.13.B.) Gas heat compartment:
1. Aluminum foil-faced fiberglass insulation shall be used.
  2. Insulation and adhesive shall meet NFPA 90A requirements for flame spread and smoke generation.

### **Part 3 — (23 09 13) Instrumentation and control devices for HVAC**

3.01 (23 09 13.23) Sensors and Transmitters

- A. (23 09 13.23.A.) Thermostats
1. Thermostat must
    - a. energize both “W” and “G” when calling for heat.
    - b. have capability to energize 2 different stages of cooling, and 2 different stages of heating.
    - c. include capability for occupancy scheduling.

### **Part 4 — (23 09 23) Direct-digital control system for HVAC**

4.01 (23 09 23.13) Decentralized, Rooftop Units:

- A. (23 09 23.13.A.) PremierLink™ controller (not compatible with SAV 2-speed indoor fan motor models)
1. Shall be ASHRAE 62 compliant.
  2. Shall accept 18-32 VAC input power.
  3. Shall have an operating temperature range from -40°F (-40°C) to 158°F (70°C), 10% to 95% RH (non-condensing).
  4. Shall include an integrated economizer controller to support an economizer with 4 to 20 mA actuator input and no microprocessor controller.
  5. Controller shall accept the following inputs: space temperature, setpoint adjustment, outdoor air temperature, indoor air quality, outdoor air quality, indoor relative humidity, compressor lock-out, fire shutdown, enthalpy, fan status, remote time clock/door switch.
  6. Shall accept a CO<sub>2</sub> sensor in the conditioned space, and be Demand Controlled Ventilation (DCV) ready.
  7. Shall provide the following outputs: economizer, fan, cooling stage 1, cooling stage 2, heat stage 1, heat stage 2, heat stage 3/exhaust/reversing valve/dehumidify/occupied.
  8. Unit shall provide surge protection for the controller through a circuit breaker.
  9. Shall be Internet capable, and communicate at a Baud rate of 38.4K or faster.
  10. Shall have an LED display independently showing the status of activity on the communication bus, and processor operation.
  11. Shall include an RS-485 protocol communication port, an access port for connection of either a computer or a Carrier technician tool, an RS-485 port for network communication to intelligent space sensors and displays, and a port to connect an optional LonWorks<sup>1</sup> plug-in communications card.
  12. Shall have built-in Carrier Comfort Network® (CCN) protocol, and be compatible with other CCN devices, including *ComfortLink* and *ComfortVIEW™* controllers.
  13. Shall have built-in support for Carrier technician tool.
  14. Software upgrades will be accomplished by local download. Software upgrades through chip replacements are not allowed.
  15. Shall be shock resistant in all planes to 5G peak, 11ms during operation, and 100G peak, 11ms during storage.

1. LonWorks is a registered trademark of Echelon Corporation.

16. Shall be vibration resistant in all planes to 1.5G at 20-300 Hz.
  17. Shall support a bus length of 4000 ft (1219 m) max, 60 devices per 1000 ft (305 m) section, and 1 RS-485 repeater per 1000 ft (305 m) sections.
- B. (23 09 23.13.B.) RTU Open protocol, direct digital controller:
1. Shall be ASHRAE 62 compliant.
  2. RTU Open controls meets California Title 24 Section 120.2i, ASHRAE 90.1-2016 and IECC-2015 Fault Detection and Diagnostic (FDD) requirements.
  3. Shall accept 18-30VAC, 50-60Hz, and consume 15VA or less power.
  4. Shall have an operating temperature range from -40°F (-40°C) to 130°F (54°C), 10% to 90% RH (non-condensing).
  5. Shall include built-in protocol for BACnet<sup>1</sup> (MS/TP and PTP modes), Modbus<sup>2</sup> (RTU and ASCII), Johnson N2 and LonWorks. LonWorks Echelon processor required for all Lon applications shall be contained in separate communication board.
  6. Shall allow access of up to 62 network variables (SNVT). Shall be compatible with all open controllers.
  7. Baud rate Controller shall be selectable using a dip switch.
  8. Shall have an LED display independently showing the status of serial communication, running, errors, power, all digital outputs, and all analog inputs.
  9. Shall accept the following inputs: space temperature, setpoint adjustment, outdoor air temperature, indoor air quality, outdoor air quality, compressor lock-out, fire shutdown, enthalpy switch, and fan status / filter status / humidity / remote occupancy.
  10. Shall provide the following outputs: economizer, variable frequency drive, fan, cooling stage 1, cooling stage 2, heat stage 1, heat stage 2, exhaust reversing valve/high fan speed.
  11. Shall have built-in surge protection circuitry through solid-state polyswitches. Polyswitches shall be used on incoming power and network connections. Polyswitches will return to normal when the “trip” condition clears.
  12. Shall have a battery backup capable of a minimum of 10,000 hours of data and time clock retention during power outages.
  13. Shall have built-in support for Carrier technician tool.
14. Shall include an RS-485 protocol communication port, an access port for connection of either a computer or a Carrier technician tool, an RS-485 port for network communication to intelligent space sensors and displays, and a port to connect an optional LonWorks communications card.
  15. Software upgrades will be accomplished by either local or remote download. No software upgrades through chip replacements are allowed.

## **Part 5 — (23 09 33) Electric and electronic control system for HVAC**

### 5.01 (23 09 33.13) Decentralized, rooftop units

#### A. (23 09 33.13.A) General:

1. Shall be complete with self-contained low-voltage control circuit protected by a resettable circuit breaker on the 24-v transformer side. Transformer shall have 75VA capability.
2. Shall utilize color-coded wiring.
3. Shall include a central control terminal board to conveniently and safely provide connection points for vital control functions such as: smoke detectors, phase monitor, gas controller, economizer, thermostat, DDC control options, and low and high pressure switches.
4. The heat exchanger shall be controlled by an integrated gas controller (IGC) microprocessor. See heat exchanger section of this specification.
5. Unit shall include a minimum of one 8-pin screw terminal connection board for connection of control wiring.

#### B. (23 09 33.23.B) Safeties:

1. Compressor over-temperature, over-current. High internal pressure differential.
2. Low-pressure switch:
  - a. Units shall have different sized connectors for the circuit 1 and circuit 2 low and high pressure switches. They shall physically prevent the cross-wiring of the safety switches between circuits 1 and 2.
  - b. Low-pressure switch shall use different color wire than the high-pressure switch. The purpose is to assist the installer and service technician to correctly wire and or troubleshoot the rooftop unit.
3. High-pressure switch:
  - a. Units shall have different sized connectors for the circuit 1 and circuit 2 low and high-pressure switches. They shall physically prevent the cross-wiring of the safety switches between circuits 1 and 2.
  - b. High-pressure switch shall use different color wire than the low-pressure switch. The purpose is to assist the installer and service technician to correctly wire and or troubleshoot the rooftop unit.

---

1. BACnet is a registered trademark of ASHRAE (American Society of Heating, Refrigerating and Air-Conditioning Engineers).

2. Modbus is a registered trademark of Schneider Electric.

4. Automatic reset, motor thermal overload protector.
5. Heating section shall be provided with the following minimum protections:
  - a. High-temperature limit switches.
  - b. Induced draft motor speed sensor.
  - c. Flame roll-out switch.
  - d. Flame proving controls.

## **Part 6 — (23 09 93) Sequence of operations for HVAC controls**

6.01 (23 09 93.13) Decentralized, Rooftop Units:

- A. (23 09 93.13.A.) INSERT SEQUENCE OF OPERATION

## **Part 7 — (23 40 13) Panel air filters**

7.01 (23 40 13 13) Decentralized rooftop units:

- A. (23 40 13 13.A.) Standard filter section
  1. Shall consist of factory-installed, low velocity, disposable 2-in. thick fiberglass filters of commercially available sizes.
  2. Unit shall use only one filter size. Multiple sizes are not acceptable.
  3. Filters shall be accessible through a dedicated, weather tight access panel with “no-tool” removal as described in the unit cabinet section of this specification (23 81 19 13.G.).

## **Part 8 — (23 81 19) Self-contained air conditioners**

8.01 (23 81 19.13) Small-Capacity Self-Contained Air Conditioners (48TC\*\*07-16)

- A. (23 81 19.13.A.) General
  1. Outdoor, rooftop mounted, electrically controlled, heating and cooling unit utilizing a fully hermetic scroll compressor(s) for cooling duty and gas combustion for heating duty.
  2. Factory assembled, single-piece heating and cooling rooftop unit. Contained within the unit enclosure shall be all factory wiring, piping, controls, and special features required prior to field startup.
  3. Unit shall use Puron® (R-410A) refrigerant.
  4. Unit shall be installed in accordance with the manufacturer’s instructions.
  5. Unit must be selected and installed in compliance with local, state, and federal codes.
- B. (23 81 19.13.B.) Quality Assurance
  1. Unit meets Department of Energy 2018 ASHRAE 90.1-2016 and IECC 2015 minimum efficiency requirements.
  2. Unit shall be rated in accordance with AHRI Standards 340/360.
  3. Unit shall be designed to conform to ASHRAE 15.
  4. Unit shall be UL-tested and certified in accordance with ANSI Z21.47 Standards and UL-listed and

certified under Canadian standards as a total package for safety requirements.

5. Insulation and adhesive shall meet NFPA 90A requirements for flame spread and smoke generation.
6. Unit casing shall be capable of withstanding 500 hour salt spray exposure per ASTM B117 (scribed specimen).
7. Roof curb shall be designed to conform to NRCA Standards.
8. Unit shall be subjected to a completely automated run test on the assembly line. The data for each unit will be stored at the factory, and must be available upon request.
9. Unit shall be designed in accordance with UL Standard 1995, ETL listed including tested to withstand rain.
10. Unit shall be constructed to prevent intrusion of snow and tested to prevent snow intrusion into the control box up to 40 mph.
11. Unit shake tested to assurance level 1, ASTM D4169 to ensure shipping reliability.
12. High Efficiency Motors listed shall meet section 313 of the Energy Independence and Security Act of 2007 (EISA 2007).
- C. (23 81 19.13.C.) Delivery, storage, and handling
  1. Unit shall be stored and handled per manufacturer’s recommendations.
  2. Lifted by crane requires either shipping top panel or spreader bars.
  3. Unit shall only be stored or positioned in the upright position.
- D. (23 81 19.13.D.) Project conditions
  1. As specified in the contract.
- E. (23 81 19.13.E.) Operating characteristics
  1. Unit shall be capable of starting and running at 115°F (46°C) ambient outdoor temperature, meeting maximum load criteria of AHRI Standard 340/360 at ± 10% voltage.
  2. Compressor with standard controls shall be capable of operation down to 40°F (4°C), ambient outdoor temperatures. Accessory winter start kit is necessary if mechanically cooling at ambient temperatures below 25°F (-4°C).
  3. Unit shall be field convertible from factory furnished vertical to horizontal airflow on all models. No special kit required on 07-14 models. Supply duct kit required for 16 size model only.
  4. Unit shall be capable of field mixed operation: vertical supply with horizontal return or horizontal supply with vertical return.
- F. (23 81 19.13.F.) Electrical Requirements
  1. Main power supply voltage, phase, and frequency must match those required by the manufacturer.



G. (23 81 19.13.G.) Unit cabinet

1. Unit cabinet shall be constructed of galvanized steel, and shall be bonderized and coated with a pre-painted baked enamel finish on all externally exposed surfaces.
2. Unit cabinet exterior paint shall be: film thickness, (dry) 0.003 inches minimum, gloss (per ASTM D523, 60°F / 16°C): 60, Hardness: H to 2H Pencil hardness.
3. Evaporator fan compartment interior cabinet insulation shall conform to AHRI Standards 340/360 minimum exterior sweat criteria. Interior surfaces shall be insulated with a minimum 1/2-in. thick, 1-lb density, flexible fiberglass insulation, neoprene coated on the air side. Aluminum foil-faced fiberglass insulation shall be used in the gas heat compartment.
4. Base of unit shall have a minimum of four locations for thru-the-base gas and electrical connections standard.
5. Base rail:
  - a. Unit shall have base rails on a minimum of 2 sides.
  - b. Holes shall be provided in the base rails for rigging shackles to facilitate maneuvering and overhead rigging.
  - c. Holes shall be provided in the base rail for moving the rooftop by fork truck.
  - d. Base rail shall be a minimum of 16 gage thickness.
6. Condensate pan and connections:
  - a. Shall be a sloped condensate drain pan made of a non-corrosive material.
  - b. Shall comply with ASHRAE Standard 62.
  - c. Shall use a 3/4-in. to 14 NPT drain connection, through the side of the drain pan. Connection shall be made per manufacturer's recommendations.
7. Top panel:
  - a. Shall be a single piece top panel on 07 through 12 sizes, two piece on 14 and 16 sizes.
8. Gas connections:
  - a. All gas piping connecting to unit gas valve shall enter the unit cabinet at a single location on side of unit (horizontal plane).
  - b. Thru-the-base capability:
    - 1.) Standard unit shall have a thru-the-base gas-line location using a raised, embossed portion of the unit basepan.
    - 2.) Thru-the-base provisions / connections are available as standard with every unit. When bottom connections are required, field furnished couplings are required.

- 3.) No basepan penetration, other than those authorized by the manufacturer, is permitted.

9. Electrical connections:

- a. All unit power wiring shall enter unit cabinet at a single, factory-prepared, knockout location.
- b. Thru-the-base capability:
  - 1.) Thru-the-base provisions / connections are available as standard with every unit. When bottom connections are required, field furnished couplings are required.
  - 2.) Optional, factory approved, water-tight connection method must be used for thru-the-base electrical connections.
  - 3.) No basepan penetration, other than those authorized by the manufacturer, is permitted.

10. Component access panels (standard):

- a. Cabinet panels shall be easily removable for servicing.
- b. Unit shall have one factory-installed, removable, tool-less filter access panel.
- c. Panels covering control box and filter shall have molded composite handles while the blower access door shall have an integrated flange for easy removal.
- d. Handles shall be UV modified, composite. They shall be permanently attached, and recessed into the panel.
- e. Screws on the vertical portion of all removable access panel shall engage into heat resistant, molded composite collars.
- f. Collars shall be removable and easily replaceable using manufacturer recommended parts.

H. (23 81 19.13.H.) Gas heat

1. General:

- a. Heat exchanger shall be an induced draft design. Positive pressure heat exchanger designs shall not be allowed.
- b. Shall incorporate a direct-spark ignition system and redundant main gas valve.
- c. Gas supply pressure at the inlet to the rooftop unit gas valve must match that required by the manufacturer.

2. The heat exchanger shall be controlled by an integrated gas controller (IGC) microprocessor.

- a. IGC board shall notify users of fault using an LED (light-emitting diode).
- b. IGC board shall contain algorithms that modify evaporator-fan operation to prevent future cycling on high temperature limit switch.
- c. Unit shall be equipped with anti-cycle protection with one short cycle on unit flame

- roll-out switch or 4 continuous short cycles on the high temperature limit switch. Fault indication shall be made using an LED.
3. Standard heat exchanger construction:
    - a. Heat exchanger shall be of the tubular-section type constructed of a minimum of 20 gage steel coated with a nominal 1.2 mil aluminum-silicone alloy to aid with corrosion resistance.
    - b. Burners shall be of the inshot type constructed of aluminum-coated steel.
    - c. Burners shall incorporate orifices for rated heat output up to 2000 ft (610 m) elevation. Additional accessory kits may be required for applications above 2000 ft (610 m) elevation, depending on local gas supply conditions.
    - d. Each heat exchanger tube shall contain multiple dimples for increased heating effectiveness.
  4. Optional stainless steel heat exchanger construction:
    - a. Use energy saving, direct-spark ignition system.
    - b. Use a redundant main gas valve.
    - c. Burners shall be of the inshot type constructed of aluminum-coated steel.
    - d. All gas piping shall enter the unit cabinet at a single location on side of unit (horizontal plane).
    - e. The optional stainless steel heat exchanger shall be of the tubular-section type, constructed of a minimum of 20 gage type 409 stainless steel.
    - f. Type 409 stainless steel shall be used in heat exchanger tubes and vestibule plate.
    - g. Complete stainless steel heat exchanger allows for greater application flexibility.
  5. Induced draft combustion motor and blower:
    - a. Shall be a direct-drive, single inlet, forward-curved centrifugal type.
    - b. Shall be made from steel with a corrosion-resistant finish.
    - c. Shall have permanently lubricated sealed bearings.
    - d. Shall have inherent thermal overload protection.
    - e. Shall have an automatic reset feature.
- I. (23 81 19.13.I.) Coils:
1. Standard aluminum fin/copper tube coils:
    - a. Standard evaporator and condenser coils shall have aluminum lanced plate fins mechanically bonded to seamless internally grooved copper tubes with all joints brazed.
    - b. Evaporator coils shall be leak tested to 150 psig, pressure tested to 450 psig, and qualified to UL 1995 burst test at 1775 psig.
    - c. Condenser coils shall be leak tested to 150 psig, pressure tested to 650 psig, and qualified to UL 1995 burst test at 1980 psig.
  2. Optional pre-coated aluminum-fin condenser coils:
    - a. Shall have a durable epoxy-phenolic coating to provide protection in mildly corrosive coastal environments.
    - b. Coating shall be applied to the aluminum fin stock prior to the fin stamping process to create an inert barrier between the aluminum fin and copper tube.
    - c. Epoxy-phenolic barrier shall minimize galvanic action between dissimilar metals.
  3. Optional copper-fin evaporator and condenser coils:
    - a. Shall be constructed of copper fins mechanically bonded to copper tubes and copper tube sheets.
    - b. Galvanized steel tube sheets shall not be acceptable.
    - c. A polymer strip shall prevent coil assembly from contacting the sheet metal coil pan to minimize potential for galvanic corrosion between coil and pan.
  4. Optional E-coated aluminum-fin, evaporator and condenser coils:
    - a. Shall have a flexible epoxy polymer coating uniformly applied to all coil surface areas without material bridging between fins.
    - b. Coating process shall ensure complete coil encapsulation of tubes, fins, and headers.
    - c. Color shall be high gloss black with gloss per ASTM D523-89.
    - d. Uniform dry film thickness from 0.8 to 1.2 mil on all surface areas including fin edges.
    - e. Superior harness characteristics of 2H per ASTM D3363-92A and cross-hatch adhesion of 4B-5B per ASTM D3359-93.
    - f. Impact resistance shall be up to 160 in.-lb (ASTM D2794-93).
    - g. Humidity and water immersion shall be up to minimum 1000 and 250 hours respectively (ASTM D2247-92 and ASTM D870-92).
    - h. Corrosion durability shall be confirmed through testing to be no less than 6000 hours salt spray per ASTM B117-90.
  5. Standard ALL Aluminum Novation® Coils (available on select models)
    - a. Standard condenser coils shall have all aluminum Novation Heat Exchanger Technology design consisting of aluminum multi-port flat tube design and aluminum fin. Coils shall

be a furnace brazed design and contain epoxy lined shrink wrap on all aluminum to copper connections.

- b. Condenser coils shall be leak tested to 150 psig, pressure tested to 650 psig, and qualified to UL 1995 burst test at 1980 psig.
6. Optional E-coated aluminum-fin, aluminum tube condenser coils:
- a. Shall have a flexible epoxy polymer coating uniformly applied to all coil external surface areas without material bridging between fins.
  - b. Coating process shall ensure complete coil encapsulation of tubes, fins, and headers.
  - c. E-coat thickness of 0.8 to 1.2 mil with top coat having a uniform dry film thickness from 1.0 to 2.0 mil on all external coil surface areas, including fin edges, shall be provided.
  - d. Shall have superior hardness characteristics of 2H per ASTM D3363-00 and cross-hatch adhesion of 4B-5B per ASTM D3359-02.
  - e. Shall have superior impact resistance with no cracking, chipping or peeling per NSF/ANSI 51-2002 Method 10.2.

J. (23 81 19.13.J.) Refrigerant components:

- 1. Refrigerant circuit shall include the following control, safety, and maintenance features:
  - a. Dual circuit — two stage cooling models (08-16) shall use fixed orifice metering system shall prevent mal-distribution of two-phase refrigerant by including multiple fixed orifice devices in each refrigeration circuit. Each orifice is to be optimized to the coil circuit it serves.
  - b. Single circuit — two stage cooling models 08, 09, and 12 shall use one fixed orifice and one TXV metering device to assist in optimum latent heat removal from a single circuit design. Model 07 units use one fixed metering device.
  - c. Refrigerant filter drier - Solid core design.
  - d. Service gage connections on suction and discharge lines.
- 2. Pressure gage access through a specially designed access port in the top panel of the unit.
- 3. There shall be gage line access port in the skin of the rooftop, covered by a black, removable plug.
  - a. The plug shall be easy to remove and replace.
  - b. When the plug is removed, the gage access port shall enable maintenance personnel to route their pressure gage lines.
  - c. This gage access port shall facilitate correct and accurate condenser pressure readings

by enabling the reading with the compressor access panel on.

- d. The plug shall be made of a leak proof, UV-resistant, composite material.
4. Compressors:
- a. Unit shall use fully hermetic, scroll compressor for each independent refrigeration circuit.
  - b. Models 08-16 with dual refrigerant circuit shall contain two scroll compressors (one per circuit), models 08, 09 and 12 with single circuit and two stage cooling shall contain one dual stage compressor. Model 07 shall contain one stage scroll compressor.
  - c. Compressor motors shall be cooled by refrigerant gas passing through motor windings.
  - d. Compressors shall be internally protected from high discharge temperature conditions.
  - e. Compressors shall be protected from an over-temperature and over-ampereage conditions by an internal, motor overload device.
  - f. Compressor shall be factory-mounted on rubber grommets.
  - g. Compressor motors shall have internal line break thermal, current overload and high pressure differential protection.
  - h. Crankcase heaters shall not be required for normal operating range, unless required by the manufacturer due to refrigerant charge limits.

K. (23 81 19.13.K.) Filter section:

- 1. Filters access is specified in the unit cabinet section of this specification.
- 2. Filters shall be held in place by a preformed, slide-out filter tray, facilitating easy removal and installation.
- 3. Shall consist of factory-installed, low velocity, throw-away 2-in. thick fiberglass filters.
- 4. Filters shall be standard, commercially available sizes.
- 5. Only one size filter per unit is allowed.

L. (23 81 19.13.L.) Evaporator fan and motor:

- 1. Evaporator fan motor:
  - a. Shall have permanently lubricated bearings.
  - b. Shall have inherent automatic-reset thermal overload protection or circuit breaker.
  - c. Shall have a maximum continuous bhp rating for continuous duty operation; no safety factors above that rating shall be required.
- 2. Belt-driven evaporator fan:
  - a. Belt drive shall include an adjustable-pitch motor pulley.
  - b. Shall use sealed, permanently lubricated ball-bearing type.
  - c. Blower fan shall be double-inlet type with forward-curved blades.

- d. Shall be constructed from steel with a finish that aids with corrosion resistance and that is dynamically balanced.
- M. (23 81 19.13.M.) Condenser and fan motors:
  - 1. Condenser fan motors:
    - a. Shall be a totally enclosed motor.
    - b. Shall use permanently lubricated bearings.
    - c. Shall have inherent thermal overload protection with an automatic reset feature.
    - d. Shall use a shaft-down design on 07 to 12 and 16 models and shaft-up on 14 size with rain shield.
  - 2. Condenser fans:
    - a. Shall be a direct-driven propeller type fan.
    - b. Shall have galvalum blades riveted to steel spiders that have corrosion-resistant properties and shall be dynamically balanced.
- N. (23 81 19.13.N.) Special features options and accessories:
  - 1. Staged Air Volume (SAV™) 2-speed indoor fan motor system shall be standard on all models with dual stage cooling (and 07 size models) to meet the Department of Energy 2018 mandatory IEER efficiency requirement. Not available on models - 08, 09, 12 with single circuit - two stage cooling:
    - a. Evaporator fan motor:
      - 1.) Shall have permanently lubricated bearings.
      - 2.) Shall have a maximum continuous bhp rating for continuous duty operation; no safety factors above that rating.
      - 3.) Shall be Variable Frequency duty and 2-speed control.
      - 4.) Shall contain motor shaft grounding ring to prevent electrical bearing fluting damage by safely diverting harmful shaft voltages and bearing currents to ground.
  - 2. Variable frequency drive (VFD):
    - a. Factory-supplied VFDs qualify, through ABB, for a 12-month warranty from date of commissioning or 18 months from date of sale, whichever occurs first.
    - b. Shall be installed inside the unit cabinet, mounted, wired and tested.
    - c. Shall contain Electromagnetic Interference (EMI) frequency protection.
    - d. Insulated gate bi-polar transistors (IGBT) used to produce the output pulse width modulated (PWM) waveform, allowing for quiet motor operation.
    - e. Self-diagnostics with fault and power code LED indicator. Field accessory Display Kit available for further diagnostics and special setup applications.
    - f. RS485 capability standard.
    - g. Electronic thermal overload protection.
    - h. 5% swinging chokes for harmonic reduction and improved power factor.
    - i. All printed circuit boards shall be conformal coated.
  - 3. Integrated EconoMi\$er® IV, EconoMi\$er 2, and EconoMi\$er X low and ultra low leak rate models:
    - a. Integrated, gear driven opposing modulating blade design type capable of simultaneous economizer and compressor operation.
    - b. Independent modules for horizontal return configuration shall be available.
    - c. Damper blades shall be galvanized steel with composite gears. Plastic or composite blades on intake or return shall not be acceptable.
    - d. Shall include all hardware and controls to provide free cooling with outdoor air when temperature and/or humidity are below setpoints.
    - e. Shall be equipped with gear driven dampers for both the outdoor ventilation air and the return air for positive air stream control.
    - f. Low leak rate models shall be equipped with dampers not to exceed 2% leakage at 1 in. wg pressure differential.
    - g. Economizer controller on EconoMi\$er IV models shall be Honeywell W7212 that provides:
      - 1.) Combined minimum and DCV maximum damper position potentiometers with compressor staging relay.
      - 2.) Functions with solid state analog enthalpy or dry bulb changeover control sensing.
      - 3.) Contain LED indicates for: when free cooling is available, when module is in DCV mode, when exhaust fan contact is closed.
    - h. Economizer controller on EconoMi\$er X models shall be the Honeywell W7220 that provides:
      - 1.) 2-line LCD interface screen for setup, configuration and troubleshooting.
      - 2.) On-board Fault Detection and Diagnostics (FDD) that senses and alerts when the economizer is not operating properly, per California Title 24.
      - 3.) Sensor failure loss of communication identification.
      - 4.) Automatic sensor detection.
      - 5.) Capabilities for use with multiple-speed indoor fan systems.
      - 6.) Utilize digital sensors: Dry bulb and Enthalpy.
    - i. Economizer controller on EconoMi\$er® 2 models with PremierLink™ controller shall be 4 to 20mA design and controlled by the PremierLink controller. PremierLink does



- not comply with California Title 24 Section 120.2i, ASHRAE 90.1-2016 and IECC-2015 Fault Detection and Diagnostic (FDD) requirements. Also meets AMCA Class 1A economizer damper test standards and labeling.
- j. Economizer controller on EconoMi\$er 2 models with RTU Open models shall be 4 to 20mA design controlled directly by the RTU Open controller. RTU Open meets California Title 24 Fault Detection and Diagnostic (FDD) requirements.
  - k. Shall be capable of introducing up to 100% outdoor air.
  - l. Shall be equipped with a barometric relief damper capable of relieving up to 100% return air and contain seals that meet ASHRAE 90.1-2016 and IECC-2015 requirements.
  - m. Shall be designed to close damper(s) during loss-of-power situations with spring return built into motor.
  - n. Dry bulb outdoor air temperature sensor shall be provided as standard. Enthalpy sensor is also available for factory-installed economizers only. Outdoor air sensor setpoint shall be adjustable and shall range from 40°F to 100°F (4°C to 38°C.) Additional sensor options shall be available as accessories.
  - o. The economizer controller shall also provide control of an accessory power exhaust unit function. Factory set at 100%, with a range of 0% to 100%.
  - p. The economizer shall maintain minimum airflow into the building during occupied period and provide design ventilation rate for full occupancy.
  - q. Dampers shall be completely closed when the unit is in the unoccupied mode.
  - r. Economizer controller shall accept a 2 to 10 Vdc CO<sub>2</sub> sensor input for IAQ/DCV control. In this mode, dampers shall modulate the outdoor air damper to provide ventilation based on the sensor input.
  - s. Compressor lockout temperature on W7220 is adjustable from -45°F to 80°F (-43°C to 27°C), set at a factory default of 32°F (0°C). Others shall open at 35°F (2°C) and closes at 50°F (10°C).
  - t. Actuator shall be direct coupled to economizer gear. No linkage arms or control rods shall be acceptable.
  - u. Economizer controller shall provide indications when in free cooling mode, in the DCV mode, or the exhaust fan contact is closed.
4. Integrated EconoMi\$er 2, and EconoMi\$er X Ultra Low Leak rate models:
- a. Integrated, gear driven opposing modulating blade design type capable of simultaneous economizer and compressor operation.
  - b. Independent modules for horizontal return configuration shall be available. Vertical return modules shall be available as a factory-installed option.
  - c. Damper blades shall be galvanized steel with composite gears. Plastic or composite blades on intake or return shall not be acceptable.
  - d. Shall include all hardware and controls to provide free cooling with outdoor air when temperature and/or humidity are below setpoints.
  - e. Shall be equipped with gear driven dampers for both the outdoor ventilation air and the return air for positive air stream control.
  - f. Ultra Low Leak design meets California Title 24 section 140.4 and ASHRAE 90.1-2016 requirements of 4 cfm per sq. ft. on the outside air dampers and 10 cfm per sq. ft. on the return dampers. Also meets AMCA Class 1A economizer damper test standards and labeling.
  - g. Economizer controller on EconoMi\$er X models shall be the Honeywell W7220 that provides:
    - 1.) 2-line LCD interface screen for setup, configuration and troubleshooting.
    - 2.) On-board Fault Detection and Diagnostics (FDD) that senses and alerts when the economizer is not operating properly, per California Title 24. Also meets AMCA Class 1A economizer damper test standards and labeling.
    - 3.) Sensor failure loss of communication identification.
    - 4.) Automatic sensor detection.
    - 5.) Capabilities for use with multiple-speed indoor fan systems.
    - 6.) Utilize digital sensors: Dry bulb and Enthalpy.
  - h. Economizer controller on EconoMi\$er<sup>®</sup> 2 models with RTU Open models shall be 4 to 20mA design controlled directly by the RTU Open controller. RTU Open meets California Title 24 Fault Detection and Diagnostic (FDD) requirements.
  - i. Shall be capable of introducing up to 100% outdoor air.
  - j. Shall be equipped with a barometric relief damper capable of relieving up to 100% return air and contain seals that meet ASHRAE 90.1-2016 requirements.

- k. Shall be designed to close damper(s) during loss-of-power situations with spring return built into motor.
  - l. Dry bulb outdoor air temperature sensor shall be provided as standard. Enthalpy sensor is also available for factory-installed economizers only. Outdoor air sensor setpoint shall be adjustable and shall range from 40°F to 100°F (4°C to 38°C). Additional sensor options shall be available as accessories.
  - m. The economizer controller shall also provide control of an accessory power exhaust unit function. Factory set at 100%, with a range of 0% to 100%.
  - n. The economizer shall maintain minimum air flow into the building during occupied period and provide design ventilation rate for full occupancy.
  - o. Dampers shall be completely closed when the unit is in the unoccupied mode.
  - p. Economizer controller shall accept a 2 to 10 Vdc CO<sub>2</sub> sensor input for IAQ/DCV control. In this mode, dampers shall modulate the outdoor air damper to provide ventilation based on the sensor input.
  - q. Compressor lockout temperature on W7220 is adjustable from -45°F to 80°F (-43°C to 27°C), set at a factory default of 32°F (0°C). Others shall open at 35°F (2°C) and closes at 50°F (10°C).
  - r. Actuator shall be direct coupled to economizer gear. No linkage arms or control rods shall be acceptable.
  - s. Economizer controller shall provide indications when in free cooling mode, in the DCV mode, or the exhaust fan contact is closed.
5. Two-Position Motorized Damper:
- a. Damper shall be a 2-position damper. Damper travel shall be from the full closed position to the field adjustable %-open setpoint.
  - b. Damper shall include adjustable damper travel from 25% to 100% (full open).
  - c. Damper shall include single or dual blade, gear driven dampers and actuator motor.
  - d. Actuator shall be direct coupled to damper gear. No linkage arms or control rods shall be acceptable.
  - e. Damper will admit up to 100% outdoor air for applicable rooftop units.
  - f. Damper shall close upon indoor (evaporator) fan shutoff and/or loss of power.
  - g. The damper actuator shall plug into the rooftop unit's wiring harness plug. No hard wiring shall be required.
6. Three-Position Motorized Damper:
- a. Damper shall be a 3-position damper. Damper travel shall be from the full closed position to the field adjustable %-open setpoint. One setting to align the first stage of indoor fan motor operation, the second to align with the full stage operation of the indoor fan motor operation. The last fully closed for the off mode.
  - b. Damper shall include adjustable damper travel from 25% to 100% (full open).
  - c. Damper shall include single or dual blade, gear driven dampers and actuator motor.
  - d. Actuator shall be direct coupled to damper gear. No linkage arms or control rods shall be acceptable.
  - e. Damper will admit up to 100% outdoor air for applicable rooftop units.
  - f. Damper shall close upon indoor (evaporator) fan shutoff and/or loss of power.
  - g. The damper actuator shall plug into the rooftop unit's wiring harness plug. No hard wiring shall be required.
  - h. Outside air hood shall include aluminum water entrainment filter.
7. Manual damper:
- a. Manual damper package shall consist of damper, air inlet screen, and rain hood which can be preset to admit up to 25% or 50% outdoor air for year round ventilation.
8. Humidi-MiZer<sup>®</sup> adaptive dehumidification system:
- a. The Humidi-MiZer Adaptive Dehumidification System shall be factory-installed in 48TC-07 and dual circuit 2-stage cooling 48TC08-16 models with RTPF (round tube plate fin) condenser coils, and shall provide greater dehumidification of the occupied space by two modes of dehumidification operations in addition to its normal design cooling mode:
    - 1.) Subcooling mode further sub cools the hot liquid refrigerant leaving the condenser coil when both temperature and humidity in the space are not satisfied.
    - 2.) Hot gas reheat mode shall mix a portion of the hot gas from the discharge of the compressor with the hot liquid refrigerant leaving the condenser coil to create a two-phase heat transfer in the system, resulting in a neutral leaving air temperature when only humidity in the space is not satisfied.
    - 3.) Includes head pressure controller.

9. Head pressure control package (Motormaster®):
    - a. Controller shall control coil head pressure by condenser-fan speed modulation or condenser-fan cycling and wind baffles.
    - b. Shall consist of solid-state control and condenser-coil temperature sensor to maintain condensing temperature between 90°F (32°C) and 110°F (43°C) at outdoor ambient temperatures down to -20°F (-29°C).
  10. Propane conversion kit:
    - a. Package shall contain all the necessary hardware and instructions to convert a standard natural gas unit for use with liquefied propane up to 2000 ft (610m) elevation
    - b. Additional accessory kits may be required for application above 2000 ft (610m) elevation.
  11. Flue shield (07-14 sizes only)
    - a. Flue shield shall provide protection from the hot sides of the gas flue hood.
  12. Condenser coil hail guard assembly (factory-installed on 3-Phase models only. Field-installed on all 3-Phase models)
    - a. Shall protect against damage from hail.
    - b. Shall be louvered style design.
  13. Unit-mounted, non-fused disconnect switch (available on units with MOCs of 80 amps or less):
    - a. Switch shall be factory-installed, internally mounted.
    - b. National Electric Code (NEC) and UL approved non-fused switch shall provide unit power shutoff.
    - c. Shall be accessible from outside the unit.
    - d. Shall provide local shutdown and lockout capability.
    - e. Sized only for the unit as ordered from the factory. Does not accommodate field-installed devices.
  14. Convenience outlet:
    - a. Powered convenience outlet:
      - 1.) Outlet shall be powered from main line power to the rooftop unit.
      - 2.) Outlet shall be powered from line side of disconnect by installing contractor, as required by code. If outlet is powered from load side of disconnect, unit electrical ratings shall be ETL certified and rated for additional outlet amperage.
      - 3.) Outlet shall be factory-installed and internally mounted with easily accessible 115-v female receptacle.
      - 4.) Outlet shall include 15 amp GFI receptacles with independent fuse protection.
      - 5.) Voltage required to operate convenience outlet shall be provided by a factory-installed step-down transformer.
    - b. Outlet shall be accessible from outside the unit.
    - 7.) Outlet shall include a field-installed "Wet in Use" cover.
  - b. Factory-installed non-powered convenience outlet:
    - 1.) Outlet shall be powered from a separate 115/120v power source.
    - 2.) A transformer shall not be included.
    - 3.) Outlet shall be factory-installed and internally mounted with easily accessible 115-v female receptacle.
    - 4.) Outlet shall include 15 amp GFI receptacles with independent fuse protection.
    - 5.) Outlet shall be accessible from outside the unit.
    - 6.) Outlet shall include a field-installed "Wet in Use" cover.
  - c. Field-installed non-powered convenience outlet:
    - 1.) Outlet shall be powered from a separate 115-120v power source.
    - 2.) A transformer shall not be included.
    - 3.) Outlet shall be factory-installed and internally mounted with easily accessible 115-v female receptacle.
    - 4.) Outlet shall include 20 amp GFI receptacles. This kit provides a flexible installation method which allows code compliance for height requirements of the GFCI outlet from the finished roof surface as well as the capability to relocate the outlet to a more convenient location.
    - 5.) Outlet shall be accessible from outside the unit.
    - 6.) Outlet shall include a field-installed "Wet in Use" cover.
15. Flue discharge deflector:
  - a. Flue discharge deflector shall direct unit exhaust vertically instead of horizontally.
  - b. Deflector shall be defined as a "natural draft" device by the National Fuel and Gas (NFG) code.
16. Thru-the-base connectors:
  - a. Kits shall provide connectors to permit gas and electrical connections to be brought to the unit through the unit basepan.
  - b. Minimum of four connection locations per unit.
17. Supply duct cover (size 16 only):
  - a. Required when field converting the factory standard vertical duct supply to horizontal duct supply configuration. One required per unit.
18. Propeller power exhaust:
  - a. Power exhaust shall be used in conjunction with an integrated economizer.

- b. Independent modules for horizontal return configurations shall be available.
  - c. Horizontal power exhaust shall be mounted in return ductwork.
  - d. Power exhaust shall be controlled by economizer controller operation. Exhaust fans shall be energized when dampers open past the 0-100% adjustable setpoint on the economizer control.
19. Roof curbs (vertical):
- a. Full perimeter roof curb with exhaust capability providing separate air streams for energy recovery from the exhaust air without supply air contamination.
  - b. Formed galvanized steel with wood nailer strip and shall be capable of supporting entire unit weight.
  - c. Permits installation and securing of ductwork to curb prior to mounting unit on the curb.
20. High altitude gas conversion kit:
- a. Package shall contain all the necessary hardware and instructions to convert a standard natural gas unit to operate from 2,000 to 7,000 ft (610 to 2134 m) elevation with natural gas from 0 to 7,000 ft (90 to 2134 m) elevation with liquefied propane.
21. Outdoor air enthalpy sensor:
- a. The outdoor air enthalpy sensor shall be used to provide single enthalpy control. When used in conjunction with a return air enthalpy sensor, the unit will provide differential enthalpy control. The sensor allows the unit to determine if outside air is suitable for free cooling.
22. Return air enthalpy sensor:
- a. The return air enthalpy sensor shall be used in conjunction with an outdoor air enthalpy sensor to provide differential enthalpy control.
23. Indoor air quality (CO<sub>2</sub>) sensor:
- a. Shall be able to provide demand ventilation indoor air quality (IAQ) control.
  - b. The IAQ sensor shall be available in duct mount, wall mount, or wall mount with LED display. The setpoint shall have adjustment capability.
24. Smoke detectors (factory-installed only):
- a. Shall be a four-wire controller and detector.
  - b. Shall be environmental compensated with differential sensing for reliable, stable, and drift-free sensitivity.
  - c. Shall use magnet-activated test/reset sensor switches.
  - d. Shall have tool-less connection terminal access.
- e. Shall have a recessed momentary switch for testing and resetting the detector.
  - f. Controller shall include:
    - 1.) One set of normally open alarm initiation contacts for connection to an initiating device circuit on a fire alarm control panel.
    - 2.) Two Form-C auxiliary alarm relays for interface with rooftop unit or other equipment.
    - 3.) One Form-C supervision (trouble) relay to control the operation of the Trouble LED on a remote test/reset station.
    - 4.) Capable of direct connection to two individual detector modules.
    - 5.) Can be wired to up to 14 other duct smoke detectors for multiple fan shutdown applications.
25. Horn/Strobe Annunciator:
- a. Provides an audible/visual signaling device for use with factory-installed option or field-installed accessory smoke detectors.
    - 1.) Requires installation of a field-supplied 24-v transformer suitable for 4.2 VA (AC) or 3.0 VA (DC) per horn/strobe accessory.
    - 2.) Requires field-supplied electrical box, North American 1-gang box, 2-in. (51 mm) x 4-in. (102 mm).
    - 3.) Shall have a clear colored lens.
26. Winter start kit:
- a. Shall contain a bypass device around the low pressure switch.
  - b. Shall be required when mechanical cooling is required down to 25°F (-4°C).
  - c. Shall not be required to operate on an economizer when below an outdoor ambient of 40°F (4°C).
27. Time guard:
- a. Shall prevent compressor short-cycling by providing a 5 minute delay (±2 minutes) before restarting a compressor after shutdown for any reason.
  - b. One device shall be required per compressor.
28. Disconnect switch bracket (16 size only):
- a. Provides a pre-engineered and sized mounting bracket for applications requiring a unit mounted fused and non-fused disconnect of greater than 100 amps. Bracket assures that no damage will occur to coils when mounting with screws and other fasteners.
29. Hinged access panels:
- a. Shall provide easy access through hinged access doors with vinyl coated door retainers.
  - b. Shall be on major panels of: filter, control box, and fan motor.



30. Display kit for variable frequency drive:
  - a. Kit allows the ability to access the VFD controller programs to provide special setup capabilities and diagnostics.
  - b. Kit contains display module and communication cable.
  - c. Display Kit can be permanently installed in the unit or used on any SAV™ 2-speed indoor fan motor system controller as needed.
31. Condensate overflow switch (for units with electro-mechanical controls or RTU Open controller only):
  - a. This sensor and related controller monitors the condensate level in the drain pan and shuts down compression operation when overflow conditions occur. It includes:
    - 1.) Indicator light — solid red (more than 10 seconds on water contact - compressors disabled), blinking red (sensor disconnected).
    - 2.) 10 second delay to break — eliminates nuisance trips from splashing or waves in pan (sensor needs 10 seconds of constant water contact before tripping).
    - 3.) Disables the compressor(s) operation when condensate plug is detected, but still allows fans to run for economizer.





