



# ICC PEI LLC

**AER-12061**

ICC PEI LLC is an accredited ISO Standard 17065 Product Certifier. This **Assembly Evaluation Report** represents a product that ICC PEI LLC has Evaluated and has an Assembly Evaluation Agreement. This **Assembly Evaluation Report** in no way implies warranty for this product or relieves ClarkDietrich of their liabilities for this product. This **AER** is an official document if it is within one year of the initial or re-approval date.

**Initial Approval**  
April, 2013

**Re-Approved**  
April, 2021

See all Reports at: [www.p-e-i.com](http://www.p-e-i.com)

### Report Owner

**ClarkDietrich®**

9050 Centre Point Drive  
Suite 400  
West Chester, OH 45069

### Additional Listees

#### **CertainTeed Gypsum**

20 Moores Road  
Malvern, PA 19335

#### **Georgia-Pacific Gypsum, LLC**

2861 Miller Road  
Decatur, GA 30035

#### **National Gypsum**

2001 Rexford Road  
Charlotte, NC 28211

#### **United States Gypsum Company**

550 West Adams Street  
Chicago, IL 60661

### Assembly

**Shaftwalls, Stairwalls & Corridors**

### For Evaluation Report Questions

[www.clarkdietrich.com](http://www.clarkdietrich.com)

### Assemblies Evaluated For

1. Transverse Load Capacity
2. Fire Resistance
3. Sound Control

### Component Descriptions

**ClarkDietrich® Shaftwall & Stairwall non-load bearing assemblies consist of the following components:**

#### **1. J-Tabbed Track / J-Runners (Part No's. TTE2, TTE4, TTE6, TTN2, TTN4)**

The metal framing members used in construction of **ClarkDietrich®** Shaftwall Systems are manufactured from cold-formed galvanized steel conforming to ASTM A1003, or other steel complying with AISI Specifications having a minimum yield strength of 33,000 or 50,000 psi. The galvanization coating shall be a ASTM A653 G40 or shall provide equivalent corrosion protection as noted in the AISI S220 specification. The available sizes are 2-1/2", 4", and 6" deep and a minimum base steel thickness of 0.0219", 0.0329", or 0.0428". These metal framing members must be third party certified to meet ICC-ES AC46.

#### **2. Steel C-T Studs (Part No's. CTE2, CTE4, CTE6, CTN2, CTN4)**

**ClarkDietrich®** Steel C-T Studs are manufactured from cold-formed galvanized steel conforming to A1003, or other steel complying with AISI specifications having a minimum yield strength of 33,000 or 50,000 psi. The galvanization coating shall be a G40 or shall provide equivalent corrosion protection per the AISI S220 (Sec A4) specification. The available sizes are 2-1/2", 4", and 6" deep and a minimum base steel thickness of 0.0219", 0.0329", or 0.0428". **ClarkDietrich®** Steel C-T Studs must be third party certified to meet ICC-ES AC46 for Cold-Formed Steel Framing Members.

#### **3. Gypsum Shaft liner Panels**

The paper-faced gypsum liner panel is utilized in the shaftwall assembly construction. The gypsum liner panels are 1" thick x 24" wide x 8' to 14' long. Any butt joints used must be factory edge to edge with pieces pushed tight together. All liner panels must be Third-Party Certified for fire rating.

#### **4. Gypsum Wallboard**

The paper-faced gypsum wallboard panels used for the Shaftwall assembly construction are of a proprietary 1/2" Type C or 5/8" Type X and must comply with, and be Third Party Certified to ASTM C1396.

### Code Compliance

2012 / 2015 International Building Code			2018 International Building Code			2021 International Building Code		
Section 703.2	Section 707.5	Section 2203.1	Section 703.2	Section 707.5	Section 2202	Section 703.2	Section 707.5	Section 2202
Section 703.3	Section 713	Section 2203.2	Section 703.3	Section 713	Section 2203	Section 703.3	Section 713	Section 2203
Section 707	Section 1206		Section 707	Section 1206		Section 707	Section 1023	
Section 707.3	Section 1207 (2015 IBC)		Section 707.3	Section 1023		Section 707.3	Section 1206	

**Shaftwalls & Stairwalls** meet the requirements of a 2-hour Fire Resistive Rated Assembly when tested in accordance with ASTM E119-08a (2012 IBC) --- ASTM E119-2012a (2015 IBC) --- ASTM E119-2016a (2018 IBC) --- ASTM E119-2018B (2021 IBC).

## ••• Fire Resistive Rated Assembly Systems •••

### Two-Hour Cavity Stairwall (Non-Load Bearing) - See Figure 1

1. A minimum 25 gauge, 2-1/2" deep **ClarkDietrich**<sup>®</sup> floor and ceiling J-runners.
2. A minimum 25 gauge, 2-1/2" deep **ClarkDietrich**<sup>®</sup> C-T studs, spaced 24" o.c. centered between the top and bottom J-Runners with a minimum 1/2" clearance from the web of the J-runner.
3. Two (2) layers of 1/2" Type C or 5/8" Type X gypsum board, one layer per side. The face layers should be installed parallel to each face of the framing members with #6 x 1" Type S drywall screws 12" o.c. (*Note - Use Type S-12 drywall screws for 20 gauge*), 1" from board ends at joints and a minimum of 3/8" from board edges. All edge and end joints should be offset from the base layer minimally 6".
4. 1" thick fire rated gypsum (Type X). The 1" liner panels should be cut 1" less than the opening height. At the ends the 1" liner panel may be retained by bending the J-runner tabs 90 degrees. If the J-runners are used at end walls, bend the J-runner tabs 90 degrees, or the 1" liner panels need to be fastened at the ends with 1-5/8" Type S screws spaced 12" o.c.
5. For more details and construction methods refer to the ClarkDietrich Installation Instructions.
6. For Fire Resistance details refer to Intertek Design No CD/WA 120-02.

### Two-Hour Cavity Shaftwall (Non-Load Bearing) - See Figure 1

1. A minimum 25 gauge, 2-1/2" deep **ClarkDietrich**<sup>®</sup> floor and ceiling J-runners.
2. A minimum 2-1/2" deep **ClarkDietrich**<sup>®</sup> C-T studs 25 gauge, centered between the top and bottom J-Runners with a minimum 1/2" clearance from the web of the J-runner.
3. The base layer of 1/2" Type C or 5/8" Type X gypsum board should be installed horizontally to the framing members with #6 x 1" Type S drywall screws, 24" o.c., starting 3" maximum from the top and bottom. The butt joint should be centered on a stud flange.
4. The face layer of 1/2" Type C or 5/8" Type X gypsum board should be installed vertically to the framing members with 1-5/8" Type S drywall screws, maximum 12" o.c. starting 6" from the top and bottom. The vertical edge and butt joints should be offset to different studs from the base layer. The horizontal butt joint in the face layer should be offset 18" from the horizontal edge joint in the base layer.
5. 1" thick fire rated (Type X) gypsum liner panel. The 1" liner panels should be cut 1" less than the opening height. At the ends of the partition the 1" liner panel may be retained by bending the J-runner tabs 90 degrees, or the 1" liner panels need to be fastened at the ends with 1-5/8" Type S screws spaced 24" o.c.
6. For more details and construction methods refer to the ClarkDietrich Installation Instructions.
7. For Fire Resistance details refer to Intertek Design No CD/WA 120-02.

### Two-Hour Corridor Ceilings - See Table 2

The Two-Hour assembly is constructed as described above in the Two-Hour Shaftwalls. See Table 2 for stud size, thickness, and maximum spans. See Figures 3 & 4 for assembly details and specifications. For additional details and construction methods refer to the ClarkDietrich Installation Instructions.

### Sound Control

The Shaftwall / Stairwall assemblies and their components mentioned in this **AER** report have been tested in accordance with ASTM E90 (90) and ASTM E413 (87). The shaftwall assemblies were evaluated for sound transmission loss values. These values are only valid if the assemblies are constructed as noted in the test reports. When the assemblies are installed in the same manner as noted in the test reports, the assembly will have a minimum STC (Sound Transmission Class) rating of 50.

### General Product Usage and Limitations

1. Shaftwall assemblies are limited to interior applications only.
2. DO NOT STACK WALLS.
3. The **ClarkDietrich**<sup>®</sup>Shaftwall/Stairwall systems should be installed according to AISI's Standard S220 - North American Standard for Cold-Formed Steel Framing - Non Structural Members and to the manufacturer's written instructions unless more stringent requirements are required.
4. The **ClarkDietrich**<sup>®</sup>Shaftwall/Stairwall systems are designed to enclose stairwells, corridors, elevator shafts, mechanical components, and other vertical shafts.
5. Non-load bearing Shaftwall / Stairwall assemblies are limited to fire-resistance only. Structural and other requirements shall be in accordance with pertinent building code and manufacturer's requirements.
6. Do not install in areas which will be adjacent to occupancies of unusually high moisture conditions.
7. C-T Studs cannot be spliced. They must be installed full length and one piece. J-runners when not attached to the structure shall not be spliced. Do not attach the J-runners to the C-T Studs unless noted otherwise by the manufacturer's installation procedures.
8. To prevent air movement, the partition perimeters, as well as all penetrations, should be effectively sealed with non-hardening sealant.
9. Applications that require the use of joint treatment shall follow the manufactures usage instructions to ensure the finishing of the joint layers is done within the temperature requirements of the product. Reference Section 715 of the 2012 International Building
10. Not recommended for use as unlined HVAC supply shafts or ducts.
11. Hollow cavities must be fire stopped at each floor.

**General Product Usage and Limitations Continued**

11. All fire resistive assemblies shall be built in accordance with the applicable published 3rd party designs, or as a otherwise described within this report.
12. Control joints should be located in way that limits the maximum continuous partition length to 30 feet. The partition control joints should coincide with the building structure where possible.
13. All Shaftwall and Stairwall members shall be simple span members with no intermediate supports.
14. Gypsum panels may be cut and stacked with joints occurring within the top and bottom third points of the wall. Joints in adjacent panels shall be alternately staggered to prevent a continuous horizontal joint. The gypsum panels must engage a minimum of two (2) tabs.
15. Openings and Penetrations in Shaftwall/Stairwell systems: As tested per ASTM E119/UL263, these system do not contain any openings or partitions.
  - All opening and penetration covering assemblies must be approved for use per section 713.7 and 713.8 of the 2018 IBC.
  - Any opening and penetration framing detail provided here is not a tested detail, but a generally accepted practiced coinciding with approved assemblies in noted statement above.
  - C-T studs are nonloadbearing, and where an Opening and Penetration is required the J-Tabbed Track must be supported by a designed structural element.
  - All opening and penetration Fire rated assemblies require independent structural support, as the Shaftwall/Stairwell systems are not designed or tested under this condition.

**Table 1 - C-T Stud Limiting Heights: per ICC-ES AC 86 1995**

Framing Depth	Steel Design Thickness & Strength	Limiting Height (feet - inches)				
		Design Deflection Limit	Design Pressure (psf)			
			5	7.5	10	15
2-1/2"	0.0231" 33,000psi	L/120	16 - 10	13 - 8	11 - 10*	8 - 6*
		L/180	13 - 8	11 - 3	9 - 10	8 - 3
		L/240	11 - 10	9 - 10	8 - 8	7 - 3
		L/360	9 - 10	8 - 3	7 - 3	6 - 2
	0.0346" 33,000psi	L/120	16 - 10	14 - 4	12 - 11	11 - 1
		L/180	14 - 4	12 - 4	11 - 1	9 - 6
		L/240	12 - 11	11 - 1	9 - 11	8 - 7
		L/360	11 - 1	9 - 6	8 - 7	7 - 5
	0.0451" 50,000psi	L/120	17 - 11	15 - 10	14 - 6	12 - 10
		L/180	15 - 10	14 - 0	12 - 10	---
		L/240	14 - 6	12 - 10	---	---
		L/360	12 - 10	---	---	---
4"	0.0231" 33,000psi	L/120	21 - 8	16 - 6*	12 - 5*	8 - 3*
		L/180	18 - 1	15 - 3	12 - 5*	8 - 3*
		L/240	16 - 0	13 - 7	12 - 1	8 - 3*
		L/360	13 - 7	11 - 6	10 - 4	8 - 3*
	0.0346" 33,000psi	L/120	23 - 0	21 - 0	18 - 7	15 - 5**
		L/180	21 - 0	17 - 9	15 - 10	13 - 6
		L/240	18 - 7	15 - 10	14 - 1	12 - 1
		L/360	15 - 10	13 - 6	12 - 1	10 - 4
	0.0451" 50,000psi	L/120	25 - 7	22 - 2	20 - 0	17 - 4
		L/180	22 - 2	19 - 2	17 - 4	15 - 1
		L/240	20 - 0	17 - 4	15 - 8	13 - 7
		L/360	17 - 4	15 - 1	13 - 7	11 - 10
6"	0.0346" 33,000psi	L/120	30 - 3**	24 - 9**	20 - 6*	13 - 8*
		L/180	30 - 3	24 - 9**	20 - 6*	13 - 8*
		L/240	26 - 6	22 - 2	19 - 7	13 - 8*
		L/360	22 - 2	18 - 8	16 - 7	13 - 8*
	0.0451" 50,000psi	L/120	36 - 5	30 - 8	27 - 3	23 - 2
		L/180	30 - 8	26 - 0	23 - 2	19 - 9
		L/240	27 - 3	23 - 2	20 - 8	17 - 8
		L/360	23 - 2	19 - 9	17 - 8	---

**Notes:**

\* Reduced for End Reaction capacity

\*\* Reduced for Flexural Strength Capacity

1. The values in this table are based on testing per ICC-ES AC 86 and ASTM E72 and represent the limiting height capacity for strength using a 1.5 Safety Factor.

2. Minimum base steel thickness is 95% of design thickness.

3. Limiting Height values shown, were assessed from the lowest Flexural Strength value of Gypsum tested.

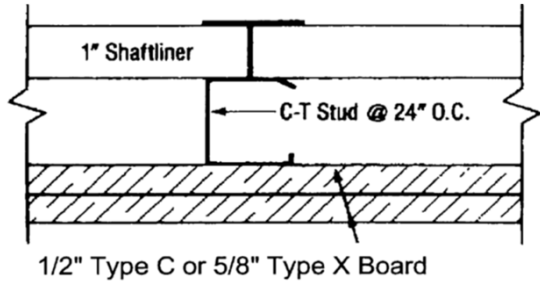

**2 HR Shaftwall Assembly- Non Load Bearing  
(Corridor side)**

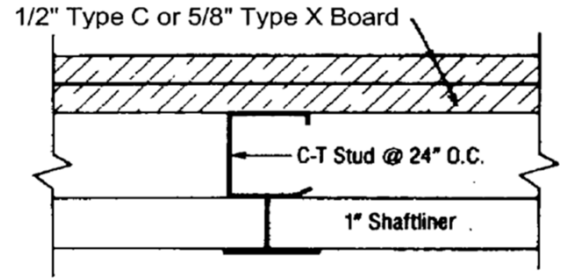

**2 HR Shaftwall Assembly - Non Load Bearing  
(Shaft Side)**

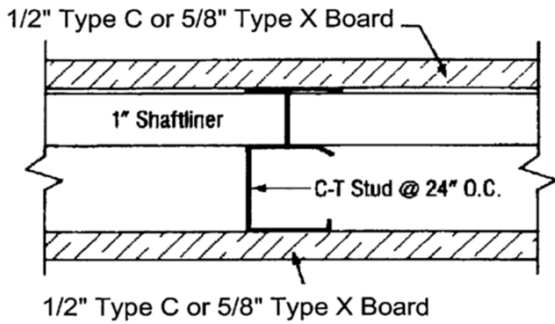

**2 HR Stairwall Assembly- Non Load Bearing  
(Room side)**

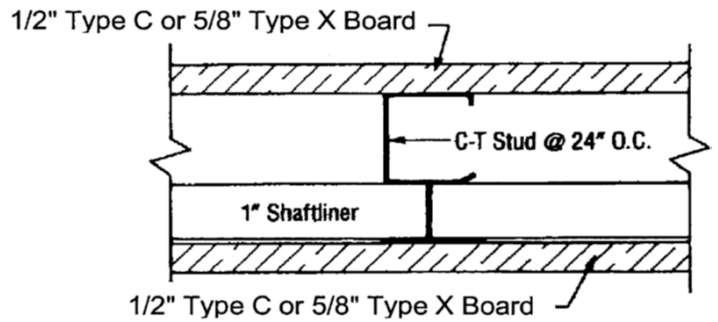

**2 HR Stairwall Assembly- Non Load Bearing  
(Stair Liner side)**

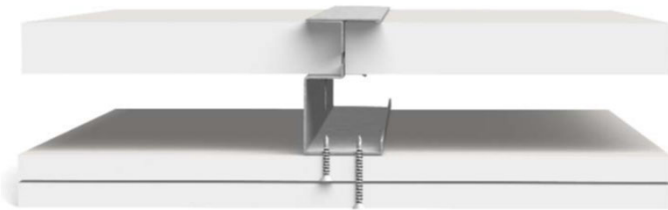

**Shaftwall**

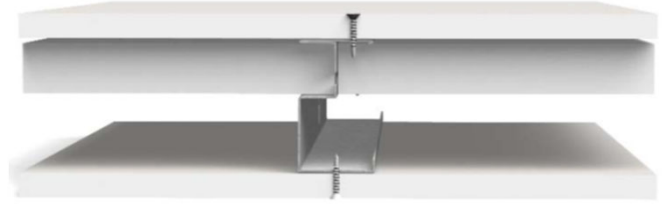

**Stairwall**



**J-Tabbed Track**



**CT-Stud**

**Figure 1 - Shaftwall Assembly Profiles for use with 1/2" Type C and 5/8" Type X Gypsum**

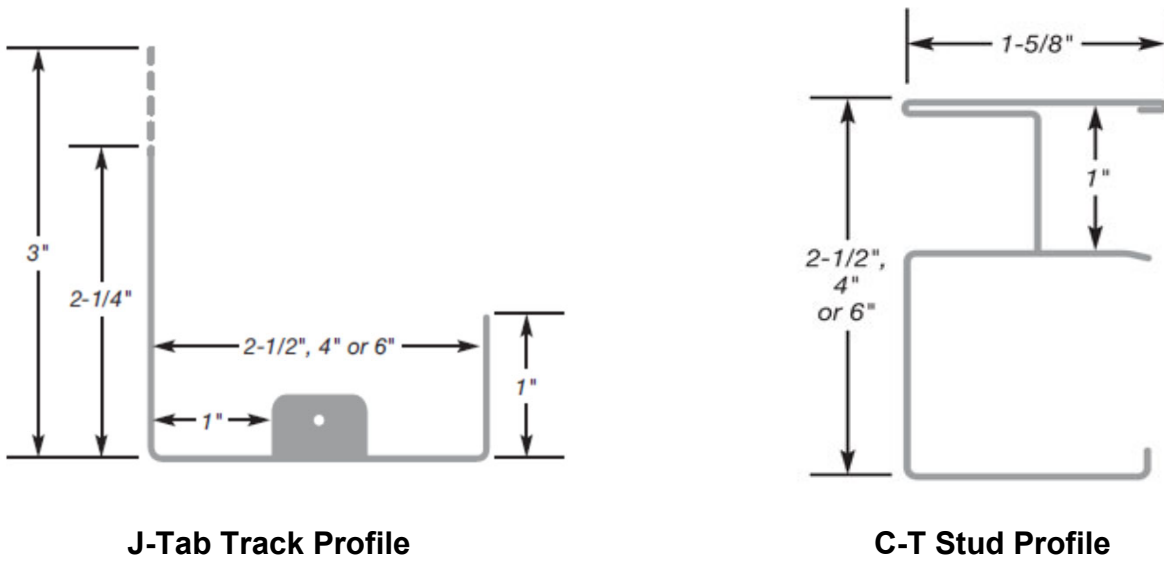

**J-Tab Track Profile**

**C-T Stud Profile**

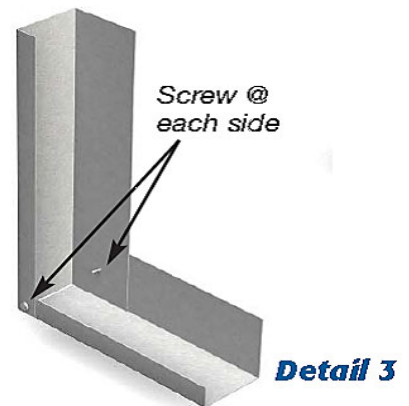
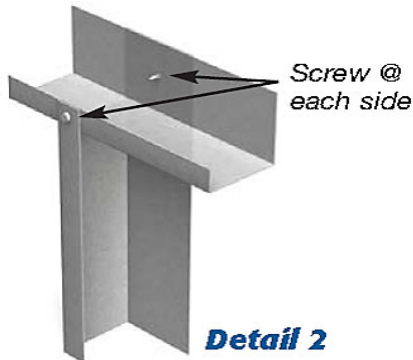
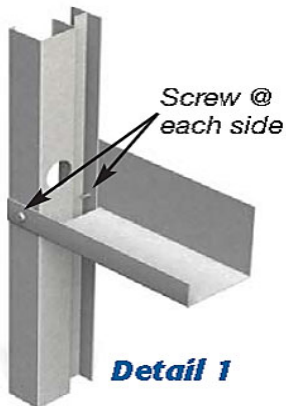
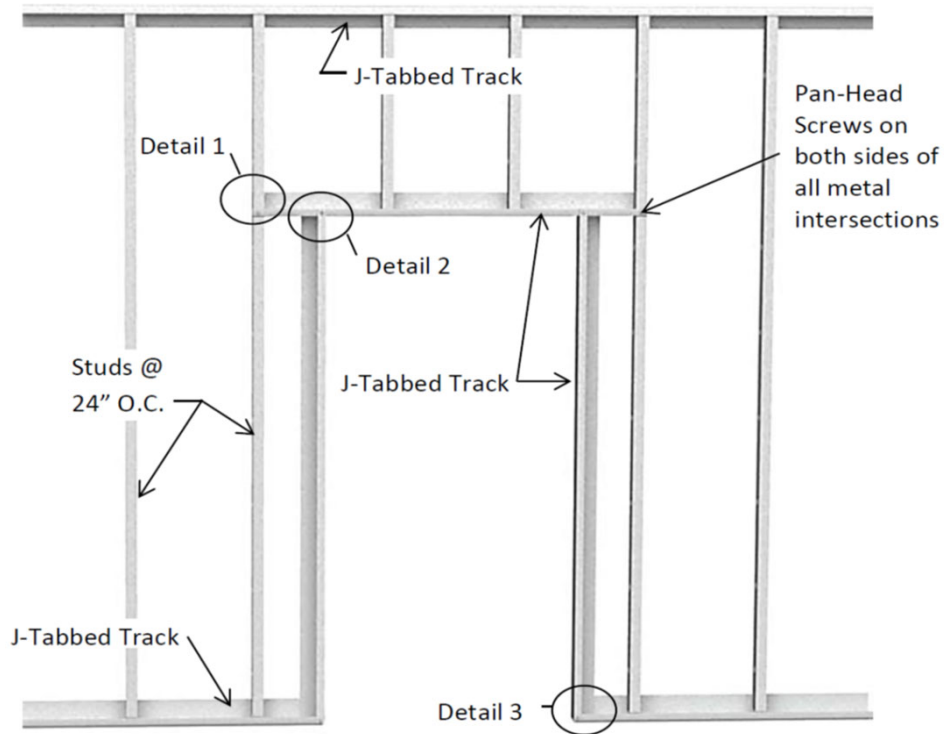

**Figure 2 - Construction Detail - Framing**

**Table 2 - Maximum Horizontal Spans for Corridor Ceilings**

Stud Depth	Reference Gauge	Minimum Steel (psi)	Design Thickness (in)	2 Hour (2) 1/2" Type C + (1) 1-in Shaft Liner				2 Hour (2) 5/8" Type X + (1) 1-in Shaft Liner			
				L / 120	L / 180	L / 240	L / 360	L / 120	L / 180	L / 240	L / 360
				2 -1/2 "	25	33,000	0.0231	8' -8"	8' -8"	8' -6"	7' -5"
	20	33,000	0.0346	10' -6"	10' -6"	9' -10"	8' -7"	9' -11"	9' -11"	9' -6"	8' -3"
4 "	25	33,000	0.0231	11' -8"	11' -8"	11' -8"	10' -8"	11' -0"	11' -0"	11' -0"	10' -3"
	20	33,000	0.0346	14' -3"	14' -3"	14' -1"	12' -4"	13' -6"	13' -6"	13' -6"	11' -10"
	18	50,000	0.0451	19' -1"	16' -8"	15' -2"	13' -3"	18' -5"	16' -1"	14' -7"	12' -9"
6 "	20	33,000	0.0346	18' -9"	18' -9"	18' -9"	16' -10"	17' -9"	17' -9"	17' -9"	16' -3"
	18	50,000	0.0451	22' -9"	22' -9"	20' -9"	18' -2"	20' -5"	20' -5"	20' -0"	17' -6"

**Notes:**

1. Dead Load of assembly ONLY is considered.
2. Not designed to carry any Live Loads, Mechanical equipment, Storage Loads or Lighting.
3. Studs must be one piece, full span.
4. Minimum base steel thickness is 95% of design thickness.
5. Verify details of construction for specific assembly to achieve required fire resistance rating and code requirements.
6. Horizontal corridor use permitted per IBC section 708.4 Continuity, Exception 3 and Exception 3 Commentary.

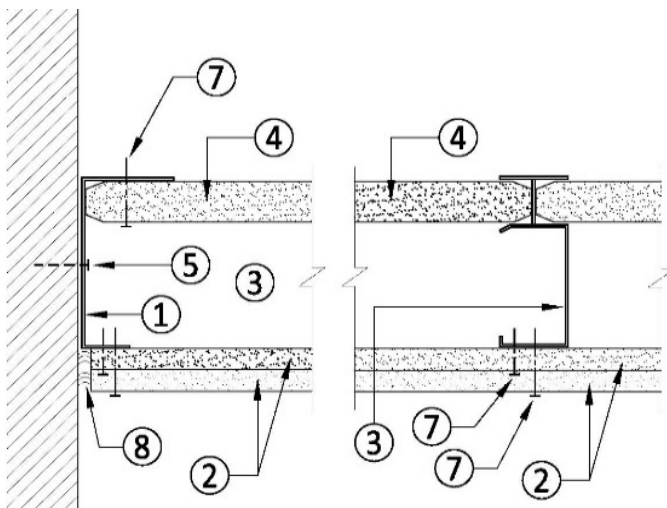

**Figure 3 - Two (2) Hour Assembly**

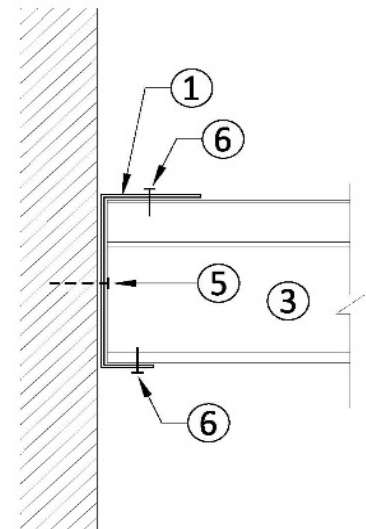

**Figure 4 - C-T Stud to J-Runner Connection**

**Figure 3 & 4 descriptions**

1. J-Track
2. Corridor Side Gypsum
3. C-T Stud (full span length)- See Table 2 above.
4. Liner Panel on top side. One seam only per stud bay allowed.
5. Fastener thru J-Track into wall at 24"o.c. maximum spacing. Fastener must provide a minimum of 200 Lbs. of shear value per C-T Stud
6. Framing fastener thru J-Track top & bottom legs into C-T Stud.
7. Gypsum fasteners thru gypsum into framing.
8. Approved Fire-Resistance joint sealant system.
9. See ClarkDietrich Horizontal Shaftwall Assembly Instructions for more details.

## **Product Labeling**

Each assembled **ClarkDietrich**® Shaft Partition System member that is covered by this **AER**, must be marked with the following information:

1. Each bundle of steel studs contains a label with the Steel Gauge and Yield Strength.
2. Each stud is identified at a maximum spacing of 96" with the **ClarkDietrich**® Name, Initials or Logo, Product Code, Minimum Base Steel Thickness, Yield Strength and **AER** Number.

## **Tested to**

**ICC-ES AC86 (1995)** - Acceptance Criteria for determining limiting height of composite walls constructed of gypsum and steel studs to revision - Date: July, 1995.

**ASTM E119** - Standard Test Methods for Fire Tests of Building Construction and Materials

**ASTM E72** - Standard Methods of Conducting Strength Test of Panels for Building Construction

**ASTM E330 (97)** - Standard Test Method for Structural Performance of Exterior Windows, Curtain Walls, Doors by Uniform Static Air Pressure Differences following Procedure A. (End Reaction Tests conducted were based on this procedure)

## **Product Documentation**

**ClarkDietrich**® Product Catalog - Dated 4/9/20

**ClarkDietrich**™ Shaftwall CT Studs/Tabbed J-Runner Quality Control Manual - **Dated 3/31/21**

**ClarkDietrich**® Installation Procedures

**ClarkDietrich**® SDS - Dated: 7/15/2018

An Assembly Evaluation Service Agreement between **Pei Evaluation Service**® and **ClarkDietrich**® Building Systems LLC

Test report No. WHI-495-1129/1130/1134/1136, Job No. 50611-C7-039510 - Report on the Fire Endurance and Hose Stream Testing of a 3-1/2" Thick Non-Bearing, Non-Symmetrical, Stairwall Assembly - Dated: 5/4/1992.

Test report No. WHI-495-1182/1186/1220/1221, Job No. 50611-C7-041450 / 042720 - Report on the Fire Endurance and Hose Stream Testing of a 3-1/2" Thick Non-Bearing, Non-Symmetrical, Stairwall Assembly - Dated: 2/8/1993.

Test report No. WHI-495-1201/1207/1208/1223, Job No. 50611-C7-041290 - Report on the Fire Endurance and Hose Stream Testing of a 3-1/2" Thick Non-Bearing, Non-Symmetrical, Stairwall Assembly - Dated: 3/12/1993.

Test report No. WHI-495-1406/1407/1410/1411 - Report on the Fire Endurance and Hose Stream Tests of a Nonsymmetrical, No-load Bearing Stairwall - Dated: 5/22/1998.

Test report No. WHI-495-1127/1128/1131/1133, Job No. 50611-C7-039510 - Report on the Fire Endurance and Hose Stream Testing of a 3-1/2" Thick, Non-Bearing, Non-Symmetrical, Shaftwall Assembly - Dated: 2/10/1992.

Test report No. WHI-495-1199/1209/1210/1224, Job No. 50611-C7-041290 - Report on the Fire Endurance and Hose Stream Testing of a 3-1/2" Thick, Non-Bearing, Non-Symmetrical, Shaftwall Assembly - 2 Hour Fire Resistance Rated - Dated: 4/14/1993.

Test report No. WHI-495-1179/1187/1188/1189, Job No. 50611-C7-041450 - Report on the Fire Endurance and Hose Stream Testing of a 3-1/2" Thick, Non-Bearing, Non-Symmetrical, Shaftwall Assembly - 2 Hour Fire Resistance Rated - Dated: 1/23/1993.

Test report No. WHI-495-1404/1405/1408/1409 - Report on the Fire Endurance and Hose Stream Tests of a Nonsymmetrical, No-load Bearing Shaftwall - Dated: 5/15/1998.

Test report No. WHI-495-TRL-0148/0203 - Report on Uniform Transverse Load Test To Determine Limiting Heights for General Construction of 2 Hour Rated Shaftwall and Stairwall Assemblies - Dated: 1/23/1995.

Test report No. RAL-TL92-42 - Report on Sound Transmission Loss per ASTM E90-90 and E413-87 - Dated: 1/30/1992.

Test report No. RAL-TL92-46 - Report on Sound Transmission Loss per ASTM E90-90 and E413-87 - Dated: 2/03/1992.

Opinion letter - Dated: 2/17/1993 for 2 Hour Rated Shaftwall and Stairwall Designs.

**ClarkDietrich**™ Research LLC - CDR Project No. 05202014 (Rev. 1.1) - 43-Mil (18-ga) ShaftWALL C-T Stud: Composite Limiting Height Calculations in Accordance with ICC-ES AC 86 - Dated: 118/2016.

A **Pei** test report No. 2002-1914 (B) - ICBO AC86 Limiting Height Test Using a 2-1/2" X 25 ga. C-T Stud in an 8 ft. Stairwall - Dated: 4/17/2003 - Stamped by a professional engineer.

A **Pei** test report No. 2002-1914 (C) - ICBO AC86 Limiting Height Test Using a 2-1/2" X 20 ga. C-T Stud in an 8 ft. Stairwall - Dated: 5/15/2003.

A **Pei** test report No. 2002-1914 (E) - ICBO AC86 Limiting Height Test Using a 4" X 20 ga. C-T Stud in an 8 ft. and 12 ft. Stairwall - Dated: 6/20/2003.

A **Pei** test report No. 2002-1914 (F) - ICBO AC86 Limiting Height Test Using a 6" X 20 ga. C-T Stud in an 8 ft. and 16 ft. Stairwall - Dated: 7/29/2003.

**Product Documentation Continued**

A *Pei* test report No. 2002-1914 (J) - ICBO AC86 Limiting Height Test Using a 2-1/2" X 20 ga. C-T Studs and 2-1/2" - 20 ga. J-Track - Dated: 8/18/2005.

A *Pei* test report No. 2002-1914 (M) - ICBO AC86 Limiting Height Test Using a 4" X 20 ga. C-T Studs and 4" - 20 ga. J-Track - Dated: 8/18/2005.

A *Pei* test report No. 2002-1914 (N) - ICBO AC86 Limiting Height Test Using a 6" X 20 ga. C-T Studs and 6" - 20 ga. J-Track - Dated: 8/18/2005.

A *Pei* test report No. 2005-436 (A) - ICC-ES AC86 Limiting Height Test Using a 2-1/2" X 25 ga. C-T Stud in an 8 ft. and 10 ft. Stairwall - Dated: 5/16/2005.

A *Pei* test report No. 2005-436 (B) - ICC-ES AC86 Limiting Height Test Using a 2-1/2" X 20 ga. C-T Stud in an 12 ft. Stairwall - Dated: 6/02/2005.

A *Pei* test report No. 2005-436 (C) - ICC-ES AC86 Limiting Height Test Using a 4" X 25 ga. C-T Stud in an 8 ft. and 12 ft. Stairwall - Dated: 6/02/2005.

A *Pei* test report No. 2005-436 (D) - End Reaction Test on a Stairwall Using 2-1/2" X 25 ga. C-T Studs with 2-1/2" 25 ga. J-Track and 4" X25 ga. C-T Studs with 4" 25 ga. J-Track - Dated: 6/02/2005.

A *Pei* test report No. 2014-0413 (A) - Evaluation of C-T Studs-18ga to ICC-ES AC86 for Use as a Shaft Wall Assembly - Dated: 2/26/2014.

A *Pei* test report No. 2014-0413 (B) - Evaluation of C-T Studs-18ga with National Gypsum Board to ICC-ES AC86 for Use as a Shaft Wall Assembly - Dated: 11/12/2015.

UL Evaluation Report No. ER3660-02 - Gypsum Shaftwall Systems Consisting of 1/2" (12.7mm) Thick Gypsum Wallboard Type C, 5/8" (15.9MM) Thick Gypsum Wallboard Type X, and 1" (25.4 mm) Thick Gypsum Wallboard Type Shaftliner - Dated July 18, 2014.

PRI Construction Materials Test Report No. NGC-026-02-01 - 1" Gold Bond® Fire-Shield® Shaftliner XP® Tested to ASTM C1396: Standard Specification for Gypsum Board - Dated February 15, 2015.

PRI Construction Materials Test Report No. NGC-016-02-01 - 5/8" Gold Bond® Fire-Shield® Shaftliner XP Tested to ASTM C1396: Standard Specification for Gypsum Board - Dated February 10, 2015.

PRI Construction Materials Test Report No. NGC-025-02-01 - 1" Gold Bond® Fire-Shield® Shaftliner Tested to ASTM C1396: Standard Specification for Gypsum Board - Dated February 15, 2015.

PRI Construction Materials Test Report No. NGC-017-02-02 - 1/2" Gold Bond® Fire-Shield C™ Gypsum Board Tested to ASTM C1396: Standard Specification for Gypsum Board - Dated March 12, 2015.