

SUMMA

F SERIES™

Professional Flatbed Systems



One machine, countless possibilities, introducing the most versatile flatbed cutting system ever.

With the F Series, Summa offers a cutting product line based on 25 years of expertise building the worlds very best cutting plotters. These advanced engineered flatbed cutting tables are capable of cutting sheet and rigid materials as well as roll stock. Up to three tools can be inserted at one time on the multi-module tool holder. Changing tools is quick and easy. Automatic tool recognition, combined with digital and mechanical depth and / or pressure control, ensures precision cutting on a wide variety of materials.

The F Series base unit comes equipped as standard with the drag knife modules and Summa's revolutionary optical camera marker recognition system for unbeatable contour cutting accuracy. Multiple material-handling options assure optimal efficiency whether cutting printed flexible or rigid substrates. An ever increasing arsenal of optional add-ons further expand the capabilities of the F Series, allowing for a custom tailored machine perfectly matched to fit your specific workflow.

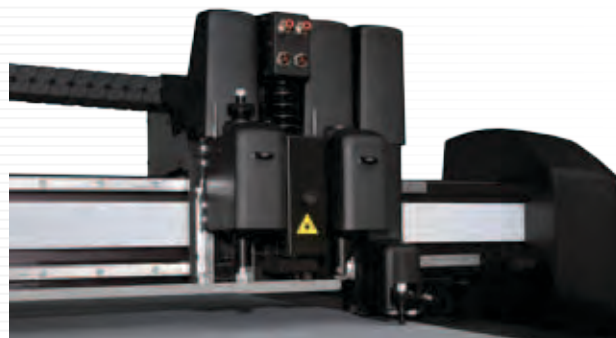

Multi-function Head

The multi-function head holds up to three modules at one time. The central unit houses a LED pointer and an integrated camera system for fast and accurate contour cutting mark recognition.



Conveyor System

This optional conveyor system and media support rollers allow the cutting / creasing / annotating of large lengths of flexible material to large production runs.



Pneumatic Pack

Optional pneumatically-driven media advance clamps hold the material down while pulling it forward in order to work continuously in panels or multiple jobs.



Vacuum Pump and Selector

The vacuum pump with sound absorber holds the material in place during the job while the selector adjust the vacuum automatically to match the working area.

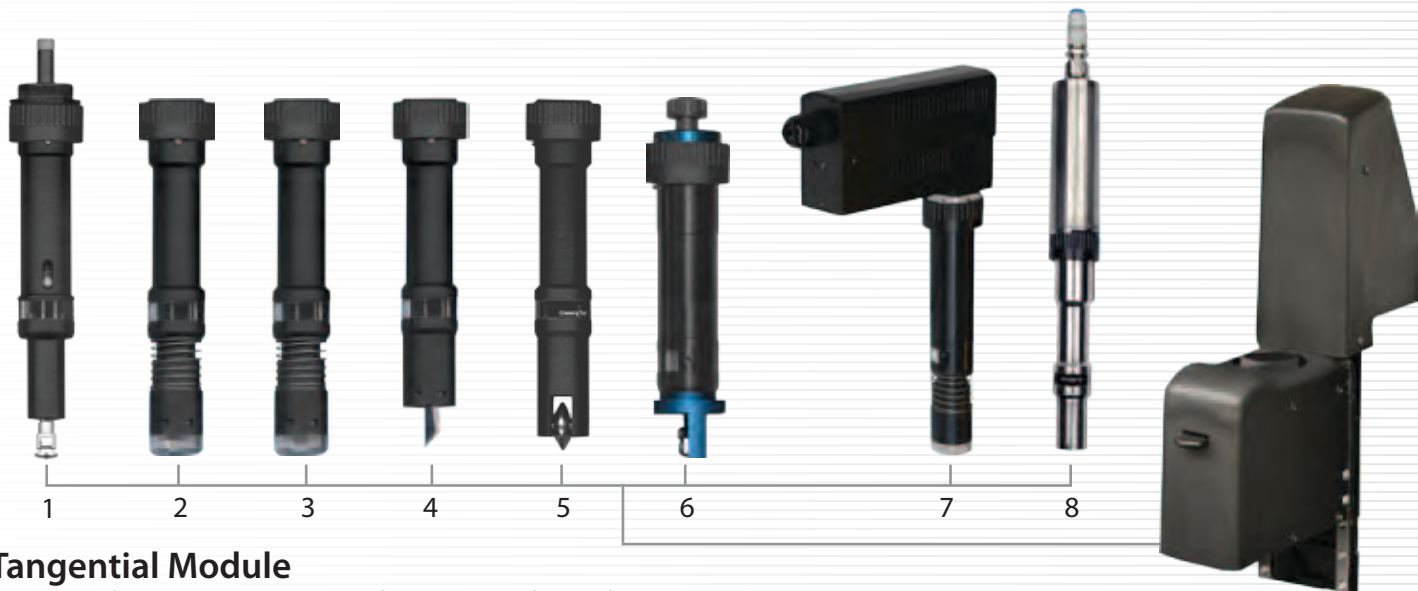

Tangential Module

The powerful tangential module offers a vertical force of 10kg and corresponds to a wide range of matching tools. Each of the many and varied tools have a barcode ID that ensures automatic recognition and parameter settings.



Tools available for the Tangential Module

For each application, a corresponding tool can be installed onto the tangential module.

1. The **Kiss Cutting Tool** is able to kiss cut the most demanding roll materials with incredible force and accuracy.
2. The **Single Edge Cutout Tool** is designed for detailed cutting through materials up to 6mm in depth.
3. The **Double Edge Cutout Tool** ensures minimal wear when cutting through tough materials up to 5mm in depth.
4. The **Heavy Duty Cutout Tool** is suitable for cutting through thicker materials up to 15mm in depth.
5. The **Creasing Wheels** are designed in several radius sizes and depth configurations to create folds in a variety of materials.
6. The **V Cut Tools** are designed in several angles to allow a v shaped groove to be cut out of thick.
7. The **Electronic Oscillating Tool** is designed for cutting through thick materials up to 10mm in depth.
8. The **Pneumatic Oscillating Tool** is designed to cut through thicker, stronger and tougher materials up to 25mm in depth.



Routing Module

The router module is capable of milling most widely used solid boards in the graphic and sign industry, such as hard foam PVC, acrylic and aluminium covered boards. The router also includes a vacuum cleaning kit to take away the chips and dust (vacuum cleaner is an optional accessory).

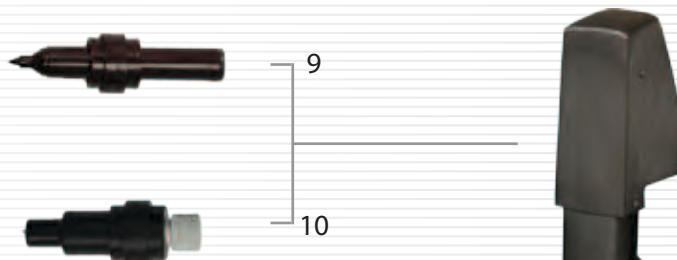

Drag Module

The drag module is a super fast module for making notations with pens⁽⁹⁾ or kiss cutting a wide range of materials with a pressure of 600 grams of down force using a drag knife⁽¹⁰⁾.



One machine, many functions.

No other machine can match the versatility and adaptability of the Summa F Series. Its heavy duty construction, accuracy and multi-function head allows you to install up to three tools simultaneously from a wide range of options making countless applications possible. Since the tools and modules can be added at any time upgrades are easy and cost-effective.



Tangential Module

The powerful tangential module offers a vertical force of 10kg and horizontal force of 20kg and corresponds to a wide range of matching tools. Each of the many and varied tools have a barcode ID that ensures automatic recognition and parameter settings. Also multiple Tangential modules can be added into the multi-function head, to allow multiple jobs to be assigned to a single machine, such as creasing and cutting without having to remove modules.

1. Kiss Cut Tool



With mechanically controlled knife pressure, this tool is specifically designed for kiss cutting materials down to their liner up to 1.2mm thick. This tool also includes an adjustable nose piece for precise depth control.

ideal for cutting

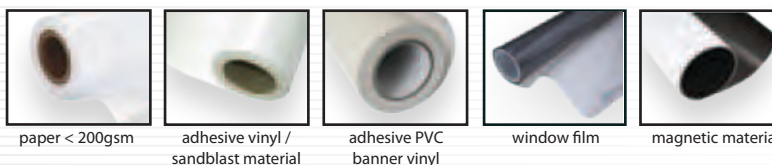

blades

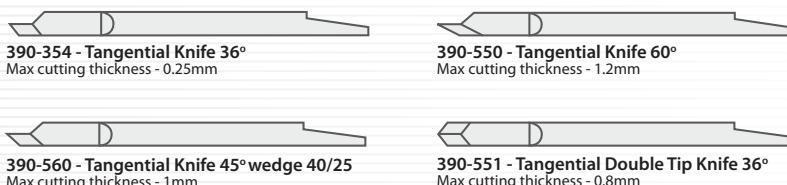

2. Single Edge Cutout Tool



The single edge cutout tool is designed for detailed cutting through materials up to 6mm in thickness. A spring loaded gliding disc permits cutting of very precise details and can be fixed at set depth.

ideal for cutting

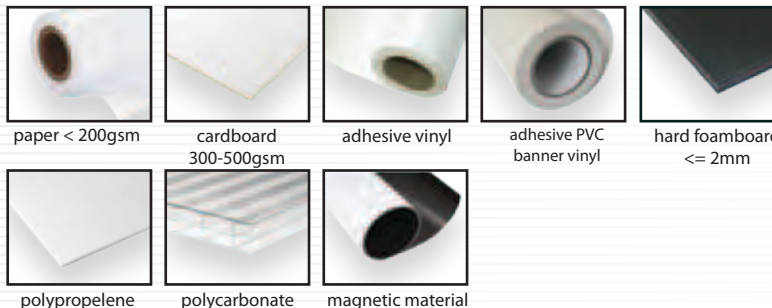

blades

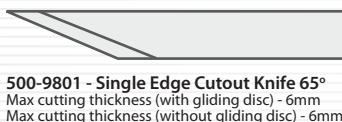

3. Double Edge Cutout Tool



The double edge cutout tool ensures minimal wear when cutting through tough materials up to 6mm in thickness. A spring loaded gliding disc permits cutting of very precise details and can be fixed at set depth.

ideal for cutting

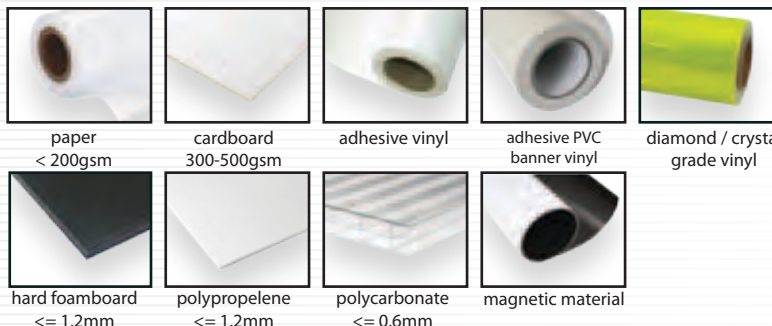

blades

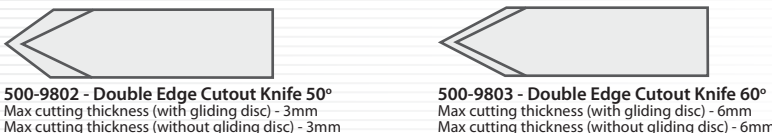

4. Heavy Duty Cutout Tool



The heavy duty cutout tool is suitable for cutting through thicker materials up to 15mm in thickness. A spring loaded gliding disc permits cutting of very precise details and can be fixed at set depth.

ideal for cutting



cardboard
300-500gsm

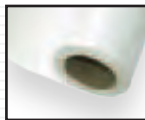

adhesive vinyl

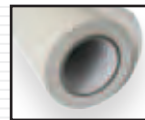

adhesive PVC
banner vinyl

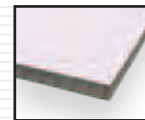

corrugated plastic
≤ 5mm

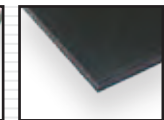

hard foamboard
≤ 1.2mm



polypropylene
≤ 1.2mm

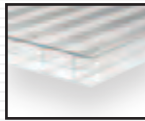

polycarbonate
≤ 0.6mm



foamboard with
paper ≤ 5mm

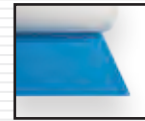

varnish blankets

blades



500-9807 - Heavy Duty Cutout Knife 45° - 90°
Max cutting thickness - 15mm

5. Creasing Wheels



Several creasing wheels designed in different depths and different radius sizes are available for creasing and scoring paper, cartons, polypropylene and PVC materials.

ideal for creasing



500-9325
Creasing Tool
D25 R3 W8

corrugated C Flute (4mm)
corrugated BC Flute (7mm)



500-9326
Creasing Tool
D25 R1.5 W8

corrugated B Flute (3mm)
corrugated C Flute (4mm)



500-9327
Creasing Tool
D25 R1.5 W1.5

corrugated E Flute (1.5mm)
corrugated B Flute (3mm)



500-9328
Creasing Tool
D15 2pt

cardboard 300 - 500gr /m²
corrugated E Flute (1.5mm)



500-9329
Creasing Tool
D25 1pt

polypropylene Sheets
≤ 1.2mm

6. V Cut Tools



Available in 5 angles the V Cut tools are designed to cut a v shaped groove in rigid sandwich and foam composite boards up to 27mm in thickness depending on the materials density.

ideal for V Groove Cutting

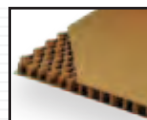

honeycomb
board

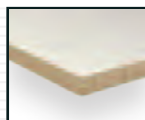

reboard

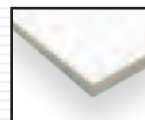

foamboard with
paper ≤ 5mm



foamboard with
paper > 5mm

blades



500-9825 - V-Cut Blade 0.9mm
Max cutting thickness (without gliding disc) - 18-27mm



500-9826 - V-Cut Hard Metal
Max cutting thickness (without gliding disc) - 18-27mm

available V Cut Tools



500-9340
V-Cut 0°



500-9341
V-Cut 15°



500-9342
V-Cut 22.5°



500-9343
V-Cut 30°



500-9344
V-Cut 45°

7. Electronic Oscillating Tool



Ideal for cutting soft and medium density materials such as foam and corrugated board up to 25mm thick. The electronic oscillating tool is driven by a 1kW electric motor producing up to 12,000 rpm and moves a knife up and down over a stroke of 1mm.

ideal for cutting

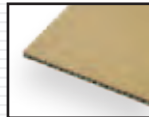

corrugated B flute (3mm)

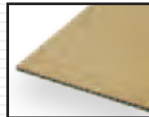

corrugated C flute (4mm)



corrugated E flute (1.5mm)

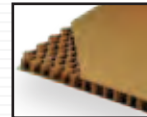

honeycomb board <= 10mm

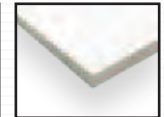

foamboard with paper <= 5mm

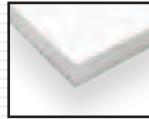

foamboard with paper > 5mm

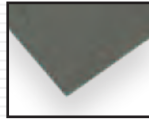

gasket

blades



500-9800 - L25 Knife 60°
Max cutting thickness (with gliding disc) - 5mm
Max cutting thickness (without gliding disc) - 5mm



500-9811 - L25 Knife 65° - 85°
Max cutting thickness (with gliding disc) - 5mm
Max cutting thickness (without gliding disc) - 11mm



500-9813 - L25 Knife 0° - 65°
Max cutting thickness (with gliding disc) - 5mm
Max cutting thickness (without gliding disc) - 6mm



500-9815 - L33 Knife 45° - 85°
Max cutting thickness (with gliding disc) - 13mm
Max cutting thickness (without gliding disc) - 19mm



500-9810 - L25 Knife 65° - 80°
Max cutting thickness (with gliding disc) - 5mm
Max cutting thickness (without gliding disc) - 11mm



500-9812 - L28 Knife 65° - 85°
Max cutting thickness (with gliding disc) - 8mm
Max cutting thickness (without gliding disc) - 14mm



500-9814 - L38 Knife 45° - 86°
Max cutting thickness (with gliding disc) - 18mm
Max cutting thickness (without gliding disc) - 24mm

8. Pneumatic Oscillating Tool



The pneumatic oscillating tool powered by compressed air moves a knife up and down over a stroke of 8mm. The robust construction of the tool makes it suitable to cut thick materials such as honeycomb board, corrugated board and foam board.

ideal for cutting

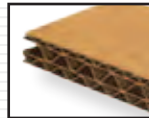

triple walled cardboard

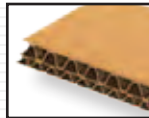

double walled cardboard

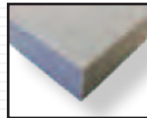

packaging foam

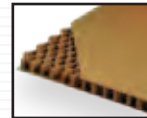

honeycomb board >= 10mm

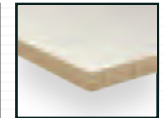

reboard

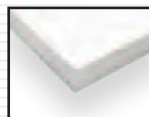

foamboard with paper > 5mm

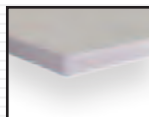

foamboard with plastic

blades



500-9830 - POT Knife Flat Point L20 T0.63
Max cutting thickness - 18mm



500-9832 - POT Knife Flat Point L20 T1.5
Max cutting thickness - 18mm

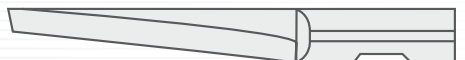

500-9800 - POT Knife Flat Point L27 T0.63
Max cutting thickness - 25mm



500-9831 - POT Knife Flat Point L27 T0.63
Max cutting thickness - 25mm

Drag Module

The drag module is a super fast module for making notations with pens or kiss cutting a wide range of materials with a pressure of 600 grams of downforce using a drag knife. Identical to the tangential module multiple drag modules can be added into the multi-function head to allow both kiss cutting and drawing completed without having to remove modules.

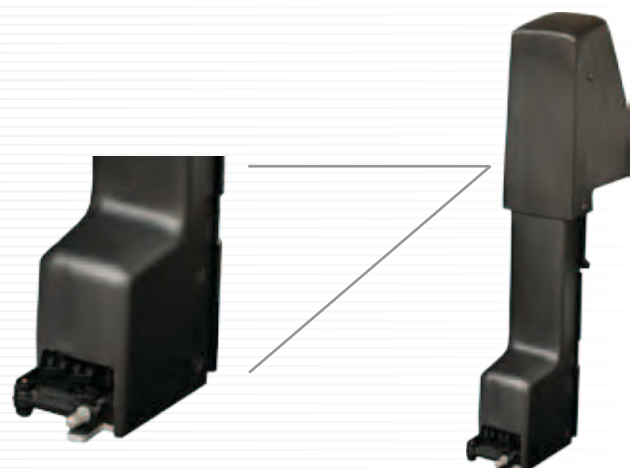

9. Drag Knife Tool



The drag knife tool is specifically designed for fast kiss cutting a wide range of materials. With 600 grams of force this is ideal for cutting through a wide range of adhesive vinyls.

ideal for cutting



paper < 200gsm

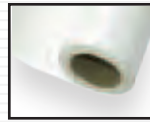

adhesive vinyl



adhesive PVC banner vinyl

blades



391-231 - Drag Knife - 60°
Max cutting thickness - 0.6mm



391-360 - Standard Knife 36°
Max cutting thickness - 0.25mm



391-358 - Drag Knife - 55°
Max cutting thickness - 0.8mm

10. Pen Tool & Universal Pen Holder Tool



Attached to the drag module this fast and accurate tool will allow precise drawing on a range of materials using either our own brand fibre tip pens or a variety of third party pencils and pens in a multitude of sizes and diameters using the universal pen holder tool.

ideal for drawing on



paper < 200gsm

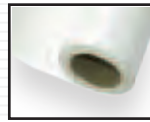

adhesive vinyl



adhesive PVC banner vinyl

pens

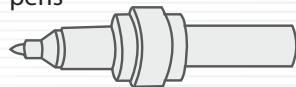

MP06BK - Fibre Tip Pen - Black

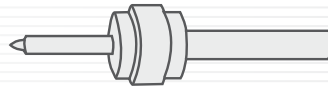

395-430/395-431 Roller Ball Pen - Black / Blue



Universal pen holder - black
accepts pen/pencils from
6.5mm to 10mm in diameter



Universal pen holder - copper
accepts pen/pencils from
9.5mm to 11mm in diameter

Routing Module



The routing module on the Summa F Series has a 1 kW motor capable of handling most solid boards in the graphic and sign industry. Hard foam PVC, acrylic and aluminium covered foam boards but also other materials like wood and MDF can be processed.



Depending on the installed bit diameter, material type and material thickness, the maximum routing speed varies. The router module comes complete with a vacuum cleaning kit to take away unwanted chips and dust. The kit includes a brush assembly, host and mounting pole (gantry). The vacuum cleaner is an optional accessory.

The router module for the F Series allocates slot 2 & 3 of the head. Slot 1 remains free for another tool. Of course the module can be easily attached to the mounting pole when not in use, making the two slots available again for other modules and tools.

The routing module is compatible with (existing) installations with 3 phase power connection. SummaFlex and SummaFlex Pro can drive the router without the need to purchase any additional software upgrades.

ideal for routing

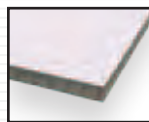

corrugated plastic

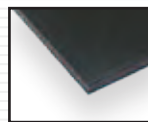

hard foamboard

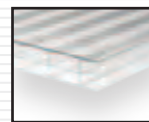

polycarbonate



plexi

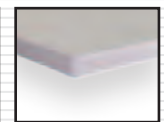

foamboard with plastic

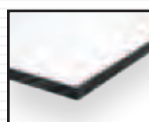

foamboard with aluminium

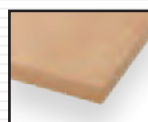

MDF

routing bits



500-9850 - Router Bit D3/3 L60/10 1FL UC



500-9851 - Router Bit D3/3 L60/20 1FL UC



500-9852 - Router Bit D4/4 L50/12 1FL UC

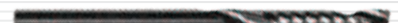

500-9853 - Router Bit D4/4 L70/30 1FL UC

SummaFlex

SummaFlex is a front end application with job preparation, post processor and import plug-ins for CAD and illustration software (e.g. Illustrator and CorelDRAW). The software integrates the F Series perfectly into your workflow needs. SummaFlex is the ideal link between your design station, RIPStation, printers and cutting devices. Once the workflow is set, macros automate the process. Consequently, the operators handling before starting the next job is reduced to a minimum as well as the downtime of the table.

SummaFlex Pro has all of the features of the standard version plus support for optical camera recognition, allowing for maximum flexibility in positioning registration marks with increased accuracy when contour cutting.

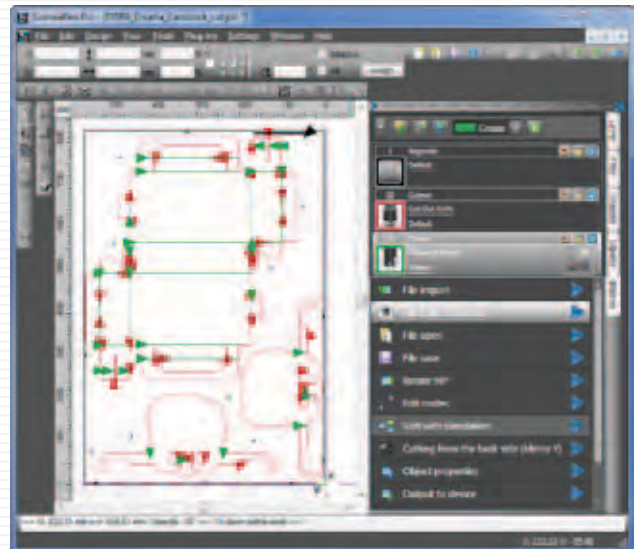

Camera recognition

The recognition process, localization of the registration marks and the process itself can be tracked in the camera preview window.

All kind of compensations and marks, which occur in everyday practice are with SummaFlex Pro manageable - no matter whether film, textiles, cardboard, ...

Barcode

Jobs can be opened using a barcode, which is provided with pre-defined output profiles.

Instead of looking for a job in the file system, only the barcode is scanned. Then, the appropriate job is loaded on the work area and can be given out immediately.



Sorting

For minimizing output time it is critical in which order objects are handled. SummaFlex has the possibility to determine start (S) and end (E) of a vector and order of processing.

Traverse path can be simulated for each layer before output. Simulation speed can be adjusted continuously.

Aim is to shorten the traverse path. A base sorting after selection of main direction is done by SummaFlex itself. Improvements can be done at any time and validated with a new simulation.

Milling

With the interactive milling function, any change in tool diameter and rotation is performed immediately and shown on the working area. The milling objects are displayed with transparent fill and full-colored radius correction. At every scaling of the milling objects a recalculation is performed.

Embossing/engraving: The to be cleared out area is provided with milling paths in a hatch or island pattern, optionally with pocket connection where the tool is not being raised.

The milling process can occur at multiple depths. All milling paths are automatically created and displayed - the tool diameter is taken into account.

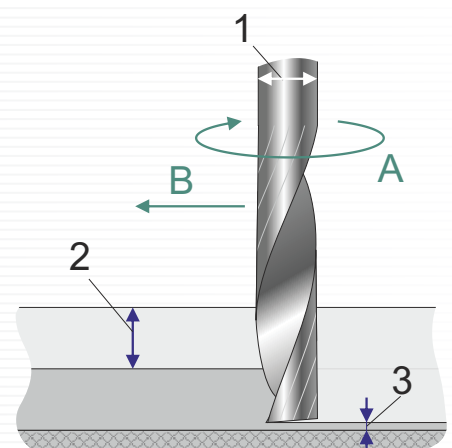



Axis Control software gives you full control over Summa's cutting table at your fingertips. The optimised design for touch screen makes Axis Control the optimum interface for the machine operator. With the supplied wireless controller, the operator is free to move around the table while changing basic settings and is included free of charge with the Summa F Series.



Extention Tables & Basket

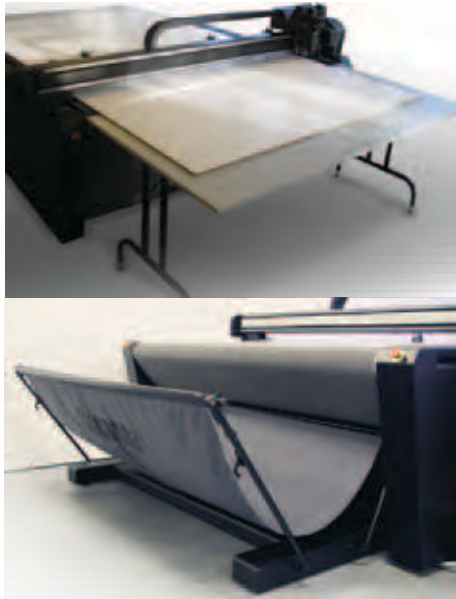

The sturdy *Extention Tables* can be placed in front and in the back of the table and adjusted to the correct height. Board material, several times longer than the F1612 working area, can be processed this way in combination with the conveyor belt system. The tables can also be used to place the next job in the queue and post process the previous job. Not in use, the tables can be folded to take minimal space.

The *Basket* is a handy tool to capture the cut-out samples and or waste material, keeping the workspace clean. It can capture several metres of material. The *Basket* is mounted on sturdy rollers casters so it can be easily moved around. Magnets keep the trolley in position when placed in front of the table. The front part can be tilted so the table is easily accessible for the operator.

The *basket* can be taken out to carry and idle it completely.

Safety Pack

The safety pack assures maximum security. A laser beam system surrounds the table and controls the motion area. The unit can then work safely, using full speed while in production mode. When put into safety mode, machine settings can be securely adjusted.

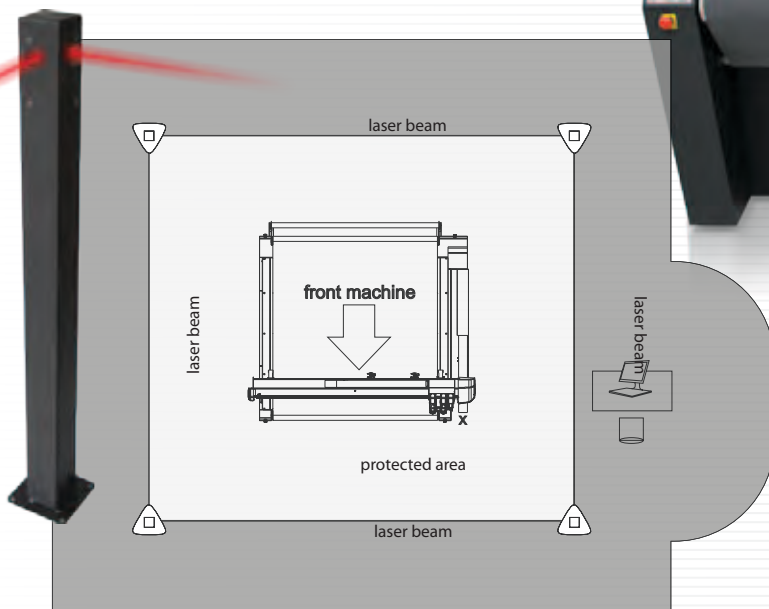
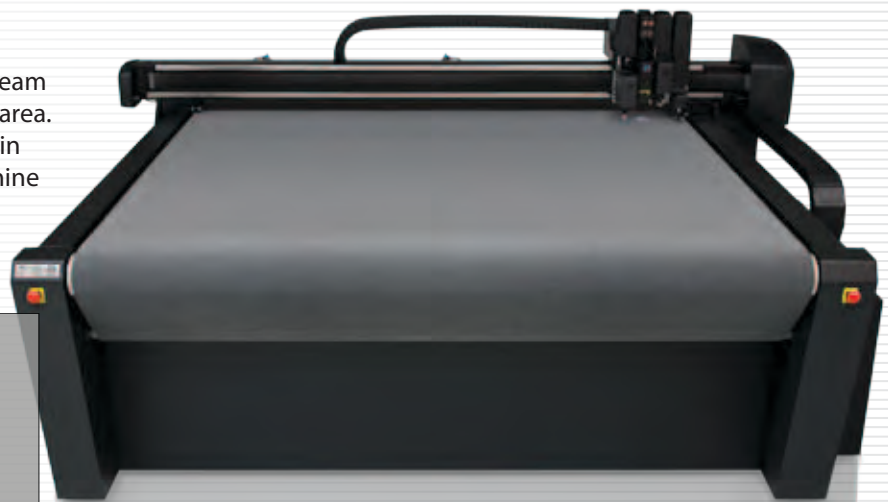

Technical Specifications

Model	F1612
Dimensions	2350mm x 1940mm x 1100 mm (without roll support) 92.5" x 76.3" x 43.3" (without roll support)
Media width	Up to 65" (1650mm)
Cutting area	1600mm (63") wide x 1200mm (47.2") long Up to 50m (164ft) long in multi panel
Repeatability	Within +/- 0.05mm on plots
Accuracy	0.05% of move or 0.05mm whichever is greater
Speed	Up to 1000mm/sec (39.4"/sec)
Acceleration	Up to 1G
Maximum Allowed Forces	Vertical: 200 newton Horizontal: 200 newton
Connectivity	USB 2.0
Requirements	3 Phase 230V or 3 Phase 400V+N

Standard Solution includes	F Series Flatbed Cutter Vacuum Pack: (1.3Kw pump, Sound Absorber, Switching Valve) Safety Pack: (Four Pole Laser Beam Systems) Camera System Axis Control Software Remote Controller with charger and USB Bluetooth Drag Module
-----------------------------------	---

Optional Modules / Upgrades	Tangential Module Router Module
------------------------------------	------------------------------------

Optional tools	Kiss Cutting Tool Single Edge Cutout Tool Double Edge Cutout Tool Heavy Duty Cutout Tool Creasing Tool D25 R3 W8 H7 Creasing Tool D25 R1.5 W8 H5.5 Creasing Tool D25 R1.5 W1.5 H1.5 Creasing Tool D15 R0.35 W0.7 - 2PT Creasing Tool D15 1PT H1.5 V Cut Tool - 0° V Cut Tool - 15° V Cut Tool - 22.5° V Cut Tool - 30° V Cut Tool - 45° Electronic Oscillating Tool Pneumatic Oscillating Tool
-----------------------	---

order codes - consumables

Consumables for Drag Module	
391-332	Drag Knife Holder for 36° & 60°
391-360	Standard Drag Knives - 36° (5x)
391-231	Drag Knife - 60°
MP06BK	Fibre Tip Pens - Black (4x)
395-430 / 395-431	Roller Ball Pens - Black / Blue
395-434	Pen Holders

Consumables for Tangential Module	
390-534	Standard Tangential Knife - 36° (5x)
390-550	Sandblast Tangential Knife - 60°
390-551	Double Tip Tangential Knife - 36°
390-560	Tangential Knife 45° Wedge 25°
390-553	Knife Install Tool
395-348	Nose Piece for 36°
500-9801	Single Edge Cutout Knife - 65°
500-9802	Double Edge Cutout Knife - 50°
500-9803	Double Edge Cutout Knife - 60°
500-9807	Heavy Duty Cutout Knife - 45° / 90°
500-9825	V Cut Blade - 0.9mm
500-9826	V Cut Blade - Hard Metal
500-3303	Gliding Disc Single Sided Knife
500-3315	Gliding Disc Double Sided Knife

Consumables for Electronic Oscillating Tool (EOT)	
500-3313	Knife Guide for EOT
500-9800	Knife for EOT L25 - 65°
500-9810	Knife for EOT L25 - 65° / 80°
500-9811	Knife for EOT L25 - 65° / 85°
500-9812	Knife for EOT L28 - 65° / 85°
500-9813	Knife for EOT L25 - 0° / 65°
500-9814	Knife for EOT L38 - 45° / 86°
500-9815	Knife for EOT L33 - 45° / 85°

Consumables for Pneumatic Oscillating Tool	
500-9830	POT Knife Flat Point L20 T0.63
500-9831	POT Knife Flat Point L27 T0.63
500-9832	POT Knife Flat Point L20 T1.5
500-9833	POT Knife Flat S Edge L27 T0.63

Consumables for Routing system	
500-9850	Routing Bits D3/3 L60/10 1FIUC (3x)
500-9851	Routing Bits D3/3 L60/20 1FIUC (3x)
500-9852	Routing Bits D3/3 L50/12 1FIUC (3x)
500-9853	Routing Bits D3/3 L70/30 1FIUC (3x)
500-0241	3mm Collet for 1050 FME
500-0242	4mm Collet for 1050 FME
500-0243	6mm Collet for 1050 FME
500-0244	8mm Collet for 1050 FME
500-9332	Vacuum Cleaner Bag (5x)

order codes - hardware

Hardware	
F1612-02	F Series F1612 Flatbed Cutter

Media Handling Options	
500-9111	Pneumatic Pack
500-9112	Roll Support
500-9113	Conveyor System
500-9121	Sturdy Folding Extension Table
500-9120	Catch Basket

Accessories	
500-9220	Base for Safety Pole
500-9331	Vacuum Cleaner for Router Module

Mats and belts	
500-9114	Conveyor System
500-9115	Protective Mat
500-9333	Routing Mat

Modules	
500-9300	Drag Module
500-9310	Tangential Module
500-9330	Router System

Tools	
500-9311	Kiss Cutting Tool
500-9312	Single Edge Cutout Tool
500-9313	Double Edge Cutout Tool
500-9314	Heavy Duty Cutout Tool
500-9325	Creasing Tool D25 R3 W8
500-9326	Creasing Tool D25 R1.5 W8
500-9327	Creasing Tool D25 R1.5 W1.5
500-9328	Creasing Tool D15 2pt
500-9329	Creasing Tool D15 1pt
500-9340	V Cut Tool - 0°
500-9341	V Cut Tool - 15°
500-9342	V Cut Tool - 22.5°
500-9343	V Cut Tool - 30°
500-9344	V Cut Tool - 45°
500-9320	Electronic Oscillating Tool
500-9350	Pneumatic Oscillating Tool

