

DTIC FILE COPY

1

1 April 1987

AD-A212 146

INDUSTRIAL TECHNOLOGY MODERNIZATION

Phase II Final Report
Project 12
Mechanical Inspection Cell



DTIC
ELECTE
SEP 06 1989
S D
CB

Prepared for
GENERAL DYNAMICS
Fort Worth, Texas

Contract No. F33657-82-C-2034



**Delco
Systems
Operations**

DELCO ELECTRONICS CORPORATION
Galesburg, California 93117

DISTRIBUTION STATEMENT A
Approved for Release
Distribution

89 9 06 151

Classified

CLASSIFICATION OF THIS PAGE

1

REPORT DOCUMENTATION PAGE

1a. REPORT SECURITY CLASSIFICATION unclassified		1b. RESTRICTIVE MARKINGS RESTRICTED	
2a. SECURITY CLASSIFICATION AUTHORITY Delco		3. DISTRIBUTION / AVAILABILITY OF REPORT No Restriction	
4a. MONITORING ORGANIZATION Delco Systems Operations		5. MONITORING ORGANIZATION REPORT NUMBER(S) DE89-0339 262-014N	
6c. ADDRESS (City, State, and ZIP Code) Goleta, CA 93117		7b. ADDRESS (City, State, and ZIP Code) Fort Worth, TX 76101	
8a. NAME OF FUNDING / SPONSORING ORGANIZATION F-16 SPO	8b. OFFICE SYMBOL (if applicable) ASD	9. PROCUREMENT INSTRUMENT IDENTIFICATION NUMBER Contract # F33657-82-C-2034 P.O. # 1005206	
8c. ADDRESS (City, State, and ZIP Code) Dayton, OH 45433		10. SOURCE OF FUNDING NUMBERS	
		PROGRAM ELEMENT NO.	TASK NO.
		PROJECT NO.	WORK UNIT ACCESSION NO.
11. TITLE (Include Security Classification) Phase 2 Final Project Report - Project 12 - Mechanical Inspection Cell			
12. PERSONAL AUTHOR(S)			
13a. TYPE OF REPORT Final	13b. TIME COVERED FROM 5-1-84 TO 1-31-87	14. DATE OF REPORT (Year, Month, Day) 87,04,01	15. PAGE COUNT 127
16. SUPPLEMENTARY NOTATION CDRL ITM-004			
17. COSATI CODES		18. SUBJECT TERMS (Continue on reverse if necessary and identify by block number)	
FIELD	GROUP	Robotic Inspection	
13	09		
19. ABSTRACT (Continue on reverse if necessary and identify by block number) This is a semiautomatic vision system to inspect part dimensions, combined with robotic gauging of threaded holes. The project is complete but never implemented due to a lack of F-16 business. → 2 pages			
DISTRIBUTION STATEMENT A Approved for public release Distribution Unlimited			
20. DISTRIBUTION / AVAILABILITY OF ABSTRACT <input checked="" type="checkbox"/> UNCLASSIFIED / UNLIMITED <input type="checkbox"/> SAME AS RPT. <input type="checkbox"/> DTIC USERS		21. ABSTRACT SECURITY CLASSIFICATION unclassified	
22a. NAME OF RESPONSIBLE INDIVIDUAL Captain Curtis Britt		22b. TELEPHONE (Include Area Code) 513-258-4263	22c. OFFICE SYMBOL YPTM

DD FORM 1473, 84 MAR

83 APR edition may be used until exhausted. All other editions are obsolete.

SECURITY CLASSIFICATION OF THIS PAGE
unclassified

~~89 6 20 139~~

1 April 1987

INDUSTRIAL TECHNOLOGY MODERNIZATION

Phase II Final Report
Project 12
Mechanical Inspection Cell



Prepared for
GENERAL DYNAMICS
Fort Worth, Texas

Contract No. F33657-82-C-2034

 **Delco
Systems
Operations**

DELCO ELECTRONICS CORPORATION
Goleta, California 93117

Accession For	
NTIS GRA&I	<input checked="" type="checkbox"/>
DTIC TAB	<input type="checkbox"/>
Unannounced	<input type="checkbox"/>
Justification	
By <i>pr call</i>	
Distribution/	
Availability Codes	
Dist	Avail and/or Special
A-1	



TABLE OF CONTENTS

		<u>PAGE</u>
1.0	Introduction	1
	1.1 Background	1
2.0	Objective	2
3.0	A Comparison of Present and Proposed Methods	3
	3.1 Present	3
	3.2 Proposed	
4.0	Proposed Technical Approach	6
	4.1 Inspection Cell Definition	6
	4.1.1 Dimensional Measurement Station	9
	4.1.2 Threaded Hole Inspection	9
	4.1.3 System Supervisory Computer	9
	4.1.4. Material Handling Robot	9
	4.1.5. Safety System	9
	4.2 Operational Inspection Sequencing	9
	4.3 System Options	12
5.0	Equipment Selection	16
	5.1 Dimensional Inspection Machine	16
	5.2 Robot	18
	5.3 Six-Axis Force Sensor	18
	5.4 System Supervisory Computer	19
6.0	Equipment Specifications	
	6.1 Dimensional Inspection Machine	20
	6.2 Robot	20
	6.3 Six-Axis Force Sensor	24
7.0	Enabling Technology Development	28
	7.1 Thread Inspection	28
	7.1.1 Background	28
	7.1.2 Testing	29
	7.2 Material Handling	29
	7.2.1 Design	55
	7.2.2 Testing	55
8.0	Proof-of-Concept Design	60
	8.1 Statement-of-Work Definition	60
	8.2 System Supervisory Computer Control Design	60
	8.2.1 View 1200	60

8.2.2	Karel Controller	61
8.3	Thread Inspection EOAT Design	62
8.3.1	Mechanical Hardware	62
8.3.2	Control Electronics/Software (Karel)	63
8.4	Lab Layout	64
9.0	Areas for Future Concern/Development	70
10.0	Final Design	71

ILLUSTRATIONS

<u>FIGURE</u>	<u>DESCRIPTION</u>	<u>PAGE</u>
1	Typical Mechanical Parts	4
2	Cell Concept	7
3	System Breakdown	8
4	EOAT-Thread Inspection	10
5	Inspection Sequence	13
6	Go Gaging Sequence	14
7	No-Go Gaging Sequence	15
8	Dimensional Inspection Comparison Matrix	17
9	View Engineering Model 1200	21
10	Accuracy Specifications	22
11	GMF S100 Robot	23
12	JR ³ Force Sensor	25
13	Torque Test Setup	30
14	Operator Test Data #1	31
15	Operator Test Data #2	32
16-24	Individual Torque vs. Gage Size (Aluminum)	33-41
25-33	Individual Torque vs. Gage Size (Steel)	42-50
34-35	Average (Steel-Aluminum)	51-52
36	Torque Threshold Guideline	53
37	4th Axis with Robotic Gripper	54
38	Part/Gripper/Pallet Cross Reference	56
39	Test Part/Pallet	57
40	Test Part/Pallet	58
41	Test Part/Pallet	59
42	EOAT Cross Section View	65
43 a,b,c	Thread Inspection Sequence	66-68
44	Laboratory Layout	69
45	4th Axis with Tooling Plate	72
46 a,b, c, d	As-is Idef Model	73-76

1.0 INTRODUCTION

↙ This report, ~~the Project 12 Final Report,~~ presents program efforts ~~during the period May 1, 1984 through January 31,~~ 1987 in support of Phase II of the Industrial Technology Modernization (ITM) program sponsored by General Dynamics, under contract No. F33657-82-C-2034. ↘ Phase II is dedicated to demonstration of enabling technologies for the factory modernization projects. → 4, 2

1.1 BACKGROUND

A Phase I Technology modernization program was performed at Delco from October 1982 through September 1983. Objectives were to conduct an analysis of manufacturing processes and facilities to be used in the production of DOD deliverable hardware, and to evaluate and identify new technology modernization projects that could, if implemented, significantly reduce deliverable unit costs. Both direct (i.e., Manufacturing Operations) activities and indirect (i.e., Manufacturing Management) activities were considered.

2.0

OBJECTIVE

fr. p. 1

As a result of the Phase I efforts conducted under the Tech Mod Program, Delco proposed to General Dynamics a continuation of the Manufacturing Modernization Program, under Phase II, A Mechanical Inspection Cell (Project 12). This project deals with the design of a work cell to automatically inspect mechanical components as a receiving inspection operation. Specific functions of this work cell were dimensional inspection, thread gaging, and material handling. (SDW) ←

3.0 A COMPARISON OF PRESENT AND PROPOSED METHODS

3.1 PRESENT

The present method of inspecting mechanical components is to manually verify each dimension using vernier calipers. Those dimensions that can not be checked with vernier calipers are checked using the appropriate gaging, such as threads/thread gage, radiuses/radius gage, center-to-centers distances of holes/coordinated measuring machine, and depths/depth micrometers.

The parts examined are primarily cast or machined aluminum and range in size from 0.375 inches to 22 inches. The parts are primarily used in military products and require thorough inspection. See Figure 1 for typical mechanical parts. A pre-selected quantity of parts from a manufacturing lot are subjected to first article examinations. These first article parts are 100% inspected for part-to-drawing conformance. The remainder of the parts from the manufacturing lot are checked for predetermined dimensions, specifically those dimensions critical to the function or assembly of the parts or those dimensions frequently not held during the machining operations. An inspection record is maintained for each part to permit quality trend reporting.

3.2 PROPOSED

3.2.1

The proposed method of dimensional inspection is to use a semi-automatic vision system whereby all part dimensions would be checked using vision system principles. This method utilizes an X-Y servo-motor-driven table with a camera mounted in the Z-axis. Since the X and Y dimensions are in the same plane, the planar dimension is established by the distance the table travels plus the camera's interpretation of the edge of the surface feature being inspected. A built-in algorithm establishes the planar dimension that has been checked. The dimension along the Z-axis is a function of the focal length of the camera. One plane is established as the zero or reference point, with the depth being a new plane requiring a new focal length. The distance the fixed focal length camera moves along a Z axis determines the Z dimension of the part feature being examined.

3.2.2

The proposed method of thread inspection will use a robotic system equipped with an end effector capable of driving a Go or No-Go gage into a tapped hole while monitoring torque. When a predetermined torque threshold, based on thread size, is attained the system will discontinue driving the gage into the part. During gage extraction revolutions will be counted allowing the depth of the threaded hole to be determined. The end effector would also contain a tool changer to accommodate differences between Go and No-Go gages.

TYPICAL MECHANICAL PARTS

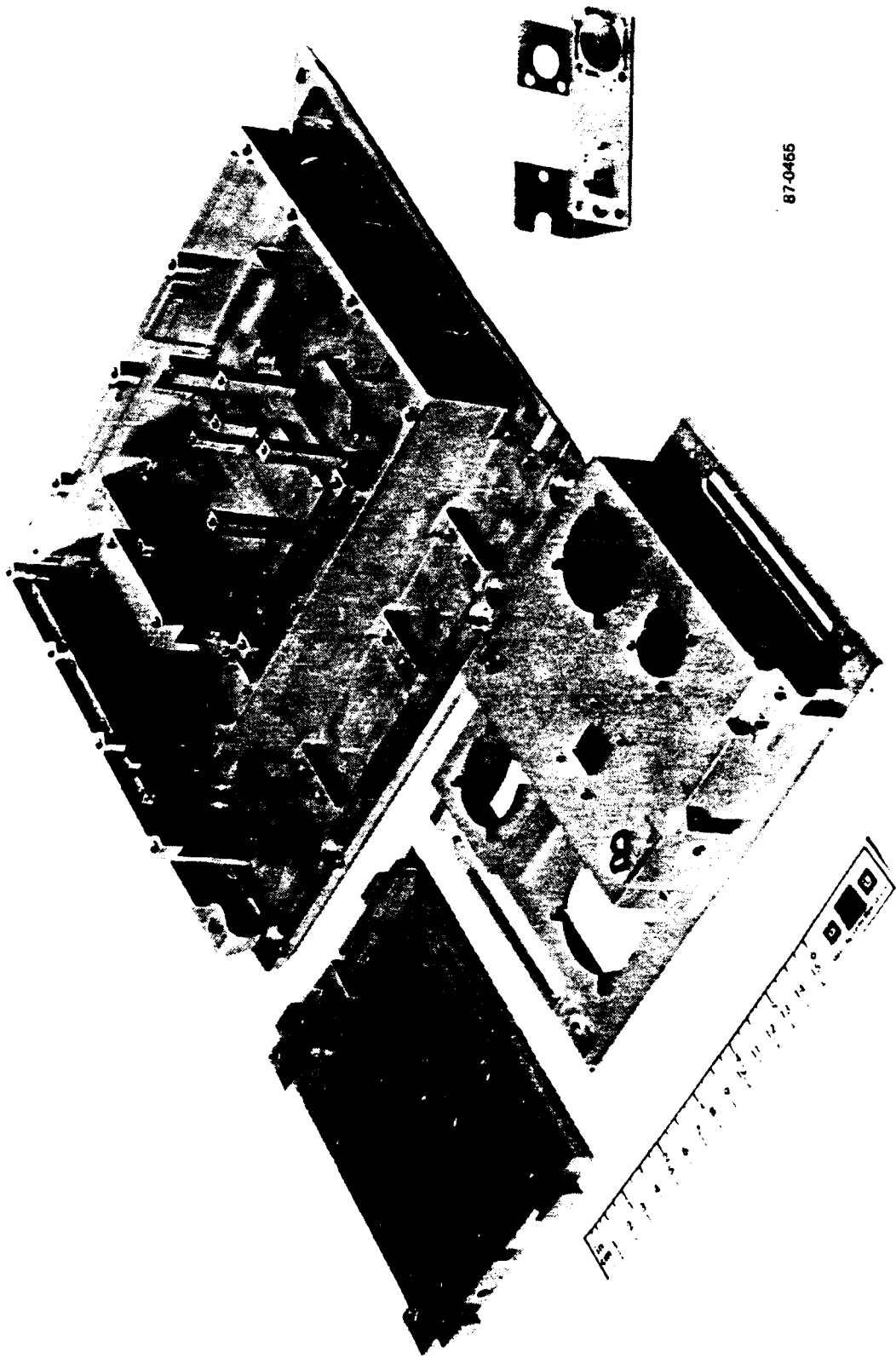

87-0455

Figure 1

3.2.3 To maximize the Workcell's throughput a material handling system would also be utilized. This system would be comprised of a robot and the necessary quick change end-effectors to handle the variety of parts the workcell would see.

4.0 PROPOSED TECHNICAL APPROACH

Based on an initial mechanical inspection cell definition, expected results from such a system, and information gathered on existing inspection equipment identified during Phase I of the ITM Program, the following scenario was generated to further define a final system's approach and design criteria. A concept layout of the inspection cell and system breakdown are shown in Figures 2 and 3.

4.1 INSPECTION CELL DEFINITION

The inspection cell shall consist of: 1) 3-dimensional vision system station to be used for measuring features of a part; 2) a robot station that would utilize modified go/no-go thread gages to inspect tapped holes; 3) a system supervisory computer to control, transfer, and store data; 4) a material handling robot system to automatically load and unload each station as required; and 5) a safety system.

The inspection cell shall have a working envelope (X,Y, Z) of 18 x 24 x 6 inches and a maximum inspected part weight of 12 lbs.

Part fixturing requirements will want to be semi-dedicated, allowing for common usage between several classes of parts to be inspected. All fixturing will also be manually loaded and unloaded.

4.1.1 DIMENSIONAL MEASUREMENT STATION

The 3-dimensional vision system chosen is a View Engineering Model 1200. It consists of: 1) A System Control Unit (SCU), 2) A Data Gathering Unit (DGU), and 3) part position monitor.

4.1.1.1 The SCU handles overall control of the vision measurement system. It includes a TV monitor, keyboard, two floppy disk drives (638K each), one 10-megabyte hard disk, and an 8086/8087 16 bit CPU. Data is downloaded to it from the primary computer and supplied software along with built-in algorithms instruct the DGU to perform all required inspections.

4.1.1.2 The DGU accomplishes the actual data measurement. It utilizes a high resolution video camera system mounted in the Z-Axis and an X-Y servo-motor-driven table onto which the part to be inspected is mounted. Since the X and Y dimensions are in the same plane, the planar dimension is established by the distance the table travels plus the camera's interpretation of the edge of the surface feature being inspected. A built-in algorithm establishes the planar dimension that has been checked. The dimension along the Z-axis is a function of the focal length of the camera. One plane is established as the zero or reference point, with the

ITM PROJECT 12 MECHANICAL INSPECTION CELL

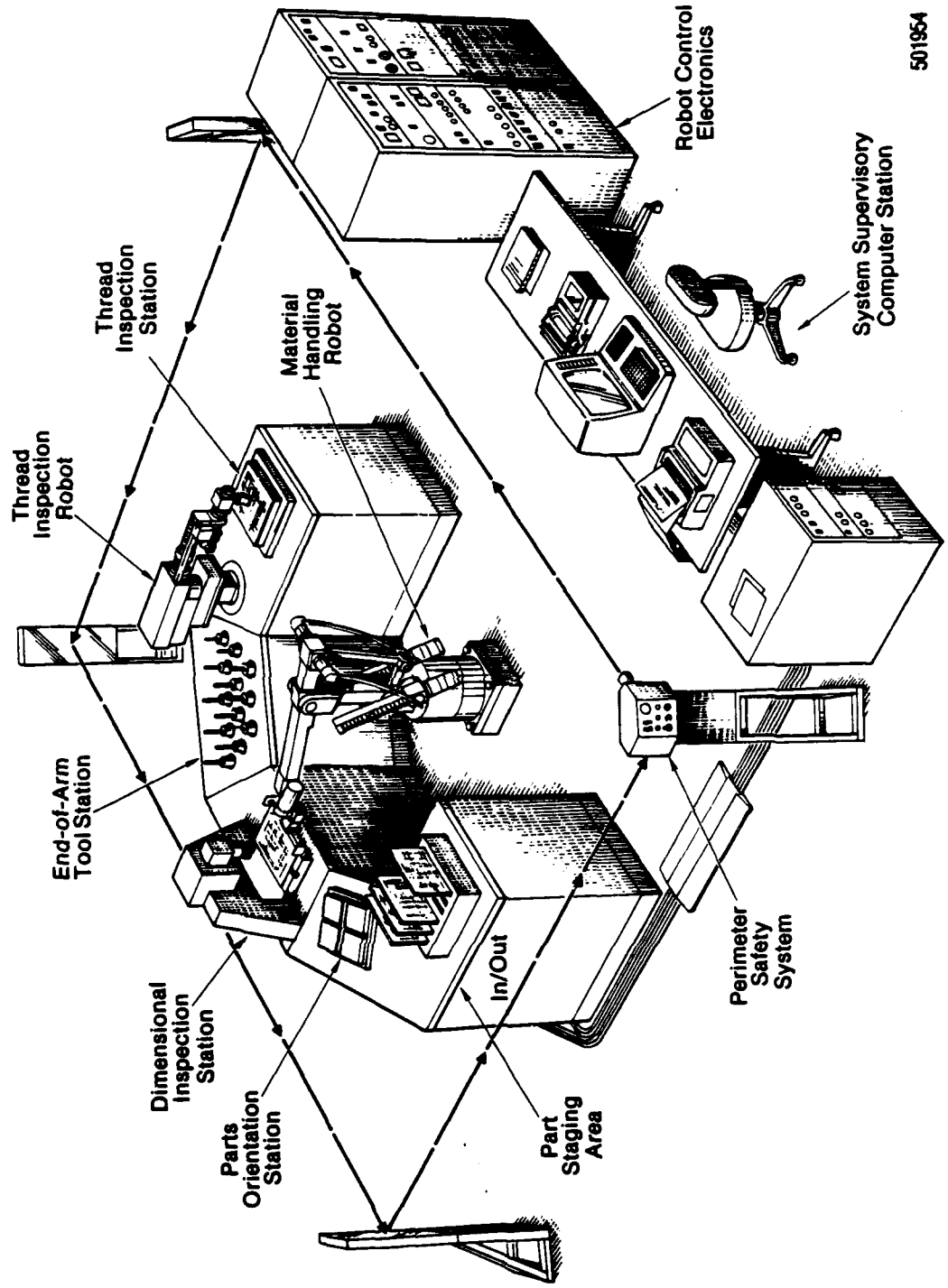
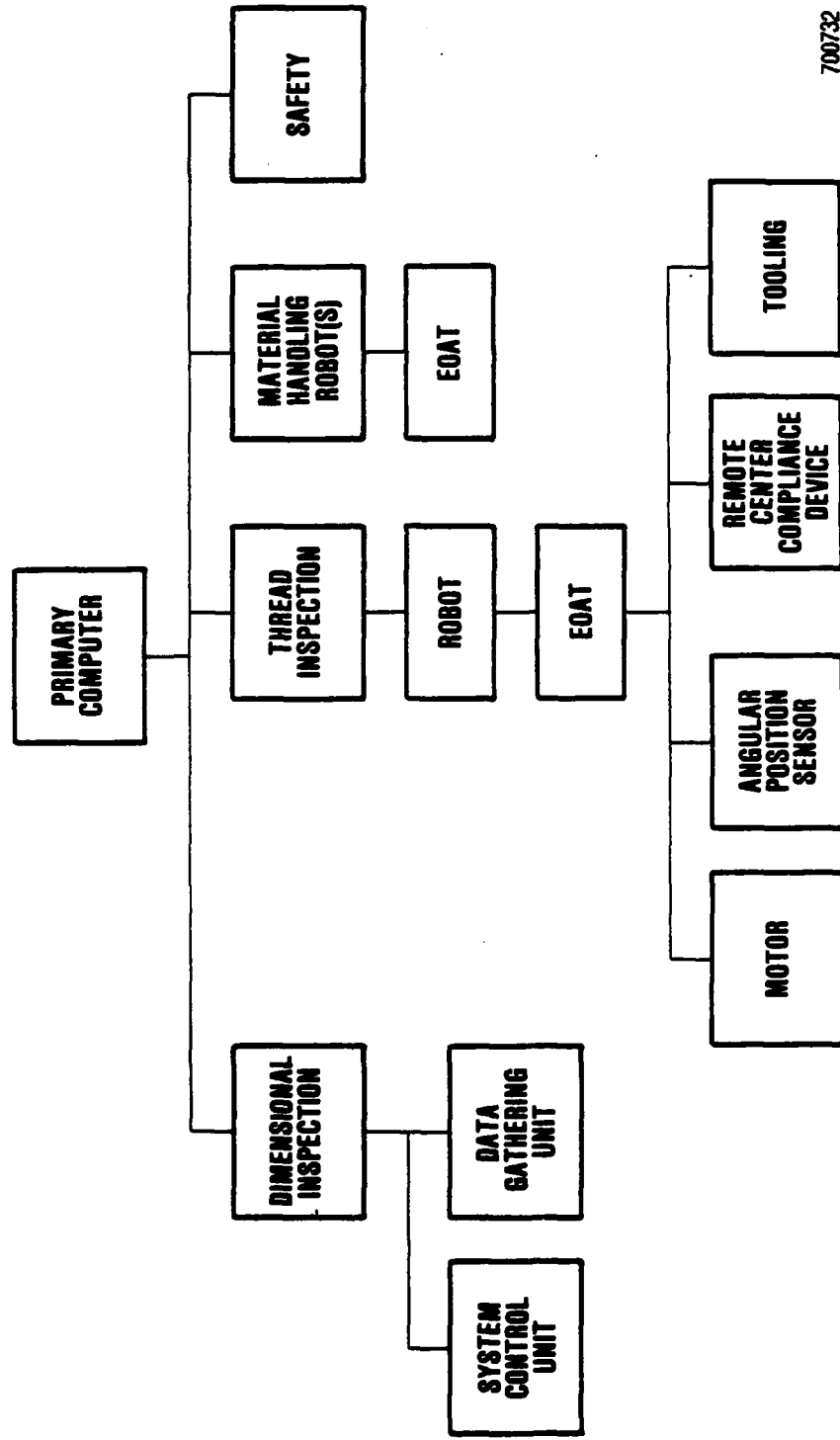

Figure 2

ITM PROJECT 12 - MECHANICAL INSPECTION CELL



700732

Figure 3

depth being a new plane requiring a new focal length. The distance the fixed focal length camera moves along a Z axis determines the Z dimension of the part feature being examined.

4.1.2 THREADED HOLE INSPECTION

Threaded hole inspection will be accomplished using robotic thread gaging. This system consists of a robot, robot controller, and end effector tooling that will inspect threaded holes (#2 through 1/4 inch) for correct size, class and thread length, per FED-STD-H28/6.

4.1.2.1 End effector tooling (see Figure 4) contains a motorized spindle capable of driving the thread gage, a rotational measurement device (Resolver/Potentiometer), a 6-axis force sensor containing a microprocessor capable of torque monitoring and force feedback to facilitate fine robot positioning, and thread gage tooling capable of automatic tool changing.

4.1.2.2 Alignment of the end effector tooling to the tapped hole shall be adequate enough to guarantee that 95% of any torque monitored will represent true torque values and not be due to side loading.

4.1.3 SYSTEM SUPERVISORY COMPUTER (SSC)

The SSC handles overall cell control. It provides for operator override, processes data, acts as a functional/maintenance/safety monitor, and stores and controls all internal and external data flow. The computer's inspection data base would be manually preprogrammed and upon completion of an inspection sequence it would store all results and print out any inspections reports as instructed.

4.1.4 MATERIAL HANDLING ROBOT

A material handling robot system will be utilized for parts transfer between the in/out station, dimensional inspection, and thread inspection stations. This robot system will also be required to act as a parts platform for the thread inspection station minimizing the requirement for dedicated worksurface tooling.

4.1.5 SAFETY SYSTEM

The inspection cell shall have a safety system that will automatically shut down all operations in areas accessible by operating robots when entered by any person.

4.2 OPERATIONAL INSPECTION SEQUENCING

During the initial development phase it will be assumed that all part fixturing will be manually loaded into each station of the inspection cell. Typical sequence of events for a part requiring both dimensional and tapped hole inspection is summarized below and presented in the flow charts of Figure 5,6 and 7.

END-OF-ARM TOOLING

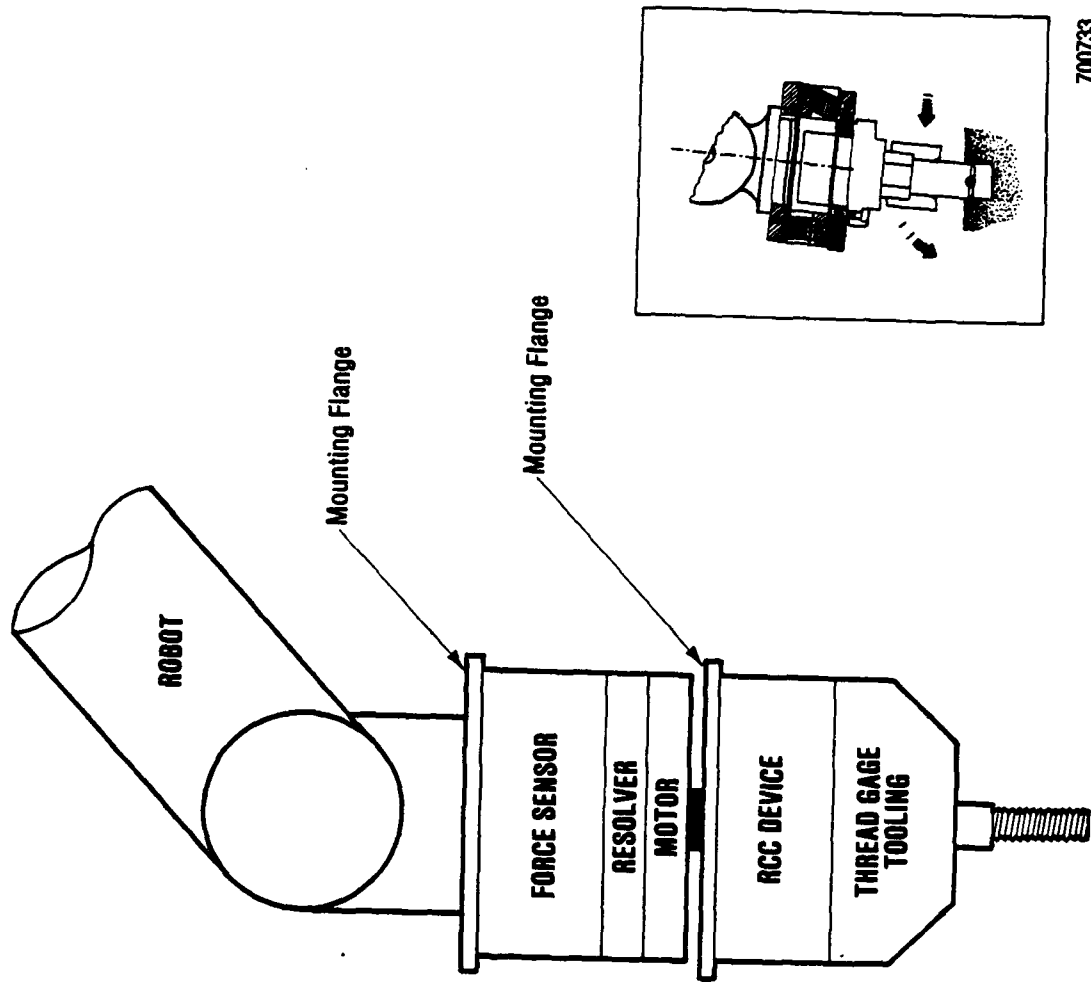

700733

Figure 4

Inspection sequence:

- 4.2.1 Primary computer is loaded with a program (via CAD or manually).
- 4.2.2 Application program required for dimensional inspection is downloaded to the dimensional inspection station System Control Unit. The part is transferred to the X-Y platform part fixturing by the material handling robot.
- 4.2.3 The dimensional inspection sequence is started.
- 4.2.4 Prompting of the material handling robot by the computer will be desired if part orientation changes are required.
- 4.2.5 After inspection of the part is complete, data is transferred back to the primary computer. Actual measurements, not desired measurements, for center-to-center distances of tapped holes may be transferred to the thread inspection station controller. (Actual dimensions will minimize control loop feedback requirements.)
- 4.2.6 Parts are then transferred from the dimensional inspection station and refixed onto the thread inspection working surface (or held by material handling robot).
- 4.2.7 The tapped hole inspection sequence is started.
- 4.2.8 Robot will select proper thread gage per downloaded application program.
- 4.2.9 Robot will center tooling with tapped hole. Robot may utilize actual measured values from the dimensional station to minimize positional corrections. Located on the hand of the robot is a 6-axis force sensor which in addition to measuring torque can sense the required compliance (see Figure 4 insert) to reposition the robot. This will minimize any binding experienced by the tooling and thereby give truer torque measurements.
- 4.2.10 When centering of the thread gaging and tapped hole is accomplished, the drive motor will be commanded to reverse rotate for 1.5 turns. This will insure that the gage and the part being inspected are not cross-threaded.
- 4.2.11 Thread gaging begins. Gage is driven into part while torque is monitored.
- 4.2.12 Should gage meet resistance (increase torque), motor would be commanded to stop. Depending on whether the gaging is "go" or "no-go" a decision would have to be made. If a "go" gage is used the system would reverse and count the number of revolutions it takes to extract the tooling, thus determining the thread length. If a "no-go" gage is used, it should meet resistance by the third entry revolution. (The system will be required to inspect eight standard and helicoil thread sizes per part [#2,#4,#6,#8, 2 @ #10, 2

@1/4" with each possibly being a Class 2 or Class 3 thread. A "go" and "no-go" gage is required for each condition [64 gages total].)

- 4.2.13 Material handling robot prompting by the controller will be desired if part orientation changes are required.
- 4.2.14 After completion of a particular gage size inspection sequence the controller will command a tool change and the inspection process continues until the part is fully inspected.
- 4.2.15 After part inspection is complete, all data is transferred from the controller to the primary computer, and an inspection report printout for the part is then made.

4.3 SYSTEM OPTIONS

The operational sequence previously presented assumes a part to be 100% inspected for both dimensions and tapped holes. The occurrence may arise where only a dimensional inspection or tapped hole inspection will be required, or only a percentage of that operation will want to be executed. For this reason part dimensions/tapped holes will want to be coded or characterized so as to facilitate this type of inspection procedure.

INSPECTION SEQUENCE

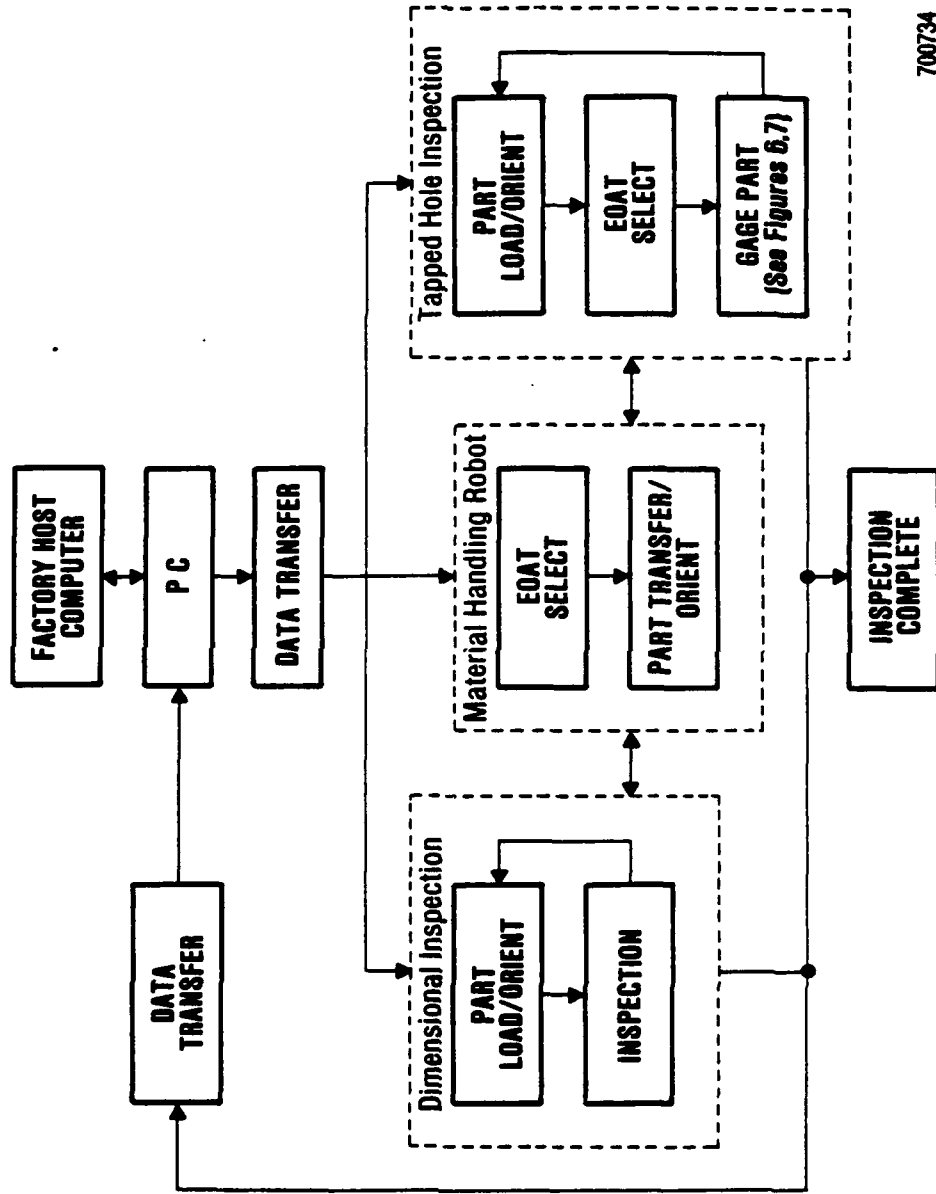
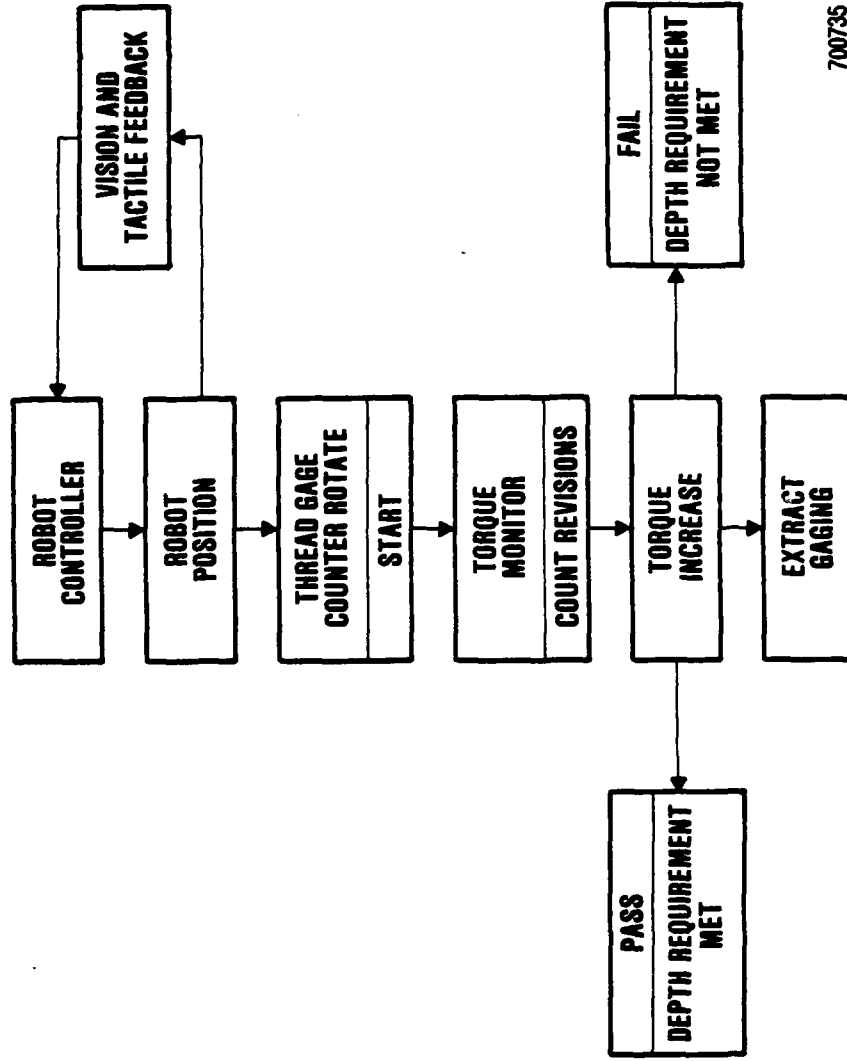

Figure 5

GO GAGING



700735

Figure 6

NO-GO GAGING

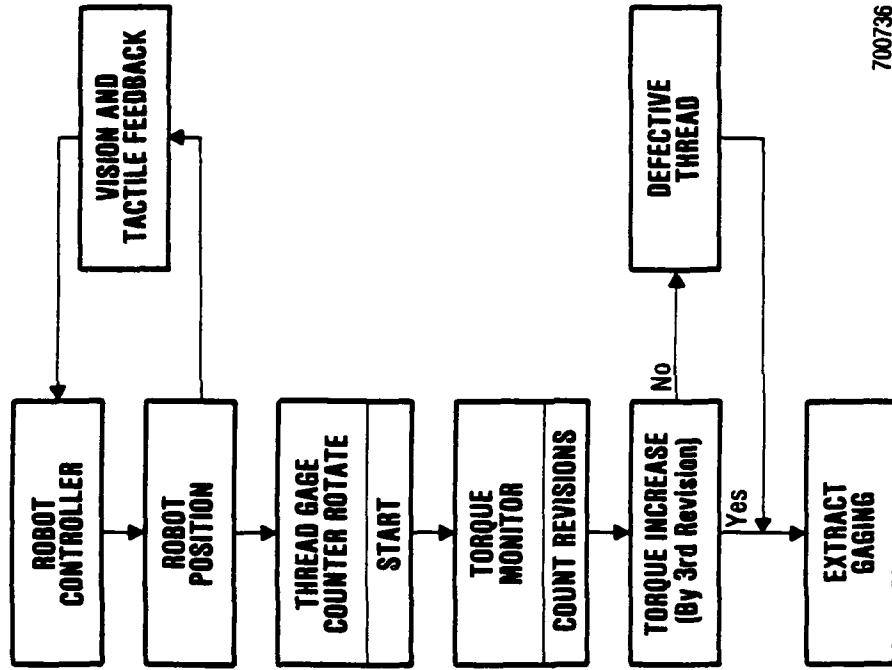

700736

Figure 7

5.0 EQUIPMENT SELECTION

Based on the proposed technical approach equipment requirements were next addressed. It was determined that four specific pieces of equipment were necessary to initiate the project. Since a final cell configuration would be dependent upon testing of this equipment, and integration of any hardware purchased into the final concept was desirable, all hardware was required to meet the most stringent specifications. These initial equipment requirements were:

1. Dimensional Inspection Machine
2. Robot
3. Six Axis Force Sensor
4. System Supervisory Computer

5.1 DIMENSIONAL INSPECTION MACHINE

At the time this survey was performed only two vendors were manufacturing equipment meeting the requirements of the project:

Rank Videometrics
411 Jarvis Ave.
Des Plaines
Ill. 60018
312-297-7720

View Engineering
1650 N. Voyager Ave.
Simi Valley, Ca. 93063
805-522-8439

Primary considerations regarding equipment selection were:

1. Operation Envelope: 18 x 18 x 6 (X,Y, Z)
2. Menu Driven
3. Accuracy - \pm .0025 inches (All Axes)
4. Supplier Support
5. Price
6. Peripheral Options

Based on available information and vendor communications a matrix comparing options and support was generated. See Figure 8. A final decision to select the View Engineering Model 1200 non-contact 3-dimensional measuring system was justified primarily on its thermal compensation, maturity of the product line (4 years) and the fact that GM is a partial owner in the company. It was felt that View's relationship with GM would gain additional leverage should modification of the equipment be required.

DIMENSIONAL INSPECTION EQUIPMENT COMPARISON MATRIX

	ACCURACY	STANDARD ELECTRONICS SUPPLIED	MAP COMPATIBILITY	MISC	PRICE
RANK VIDEO-METRICS	X-Y-Z ± .0025 @ 68°F ± 2°	<ul style="list-style-type: none"> ● 768k Memory ● 12" CRT ● 2 Flex 3.5" Disk Drives (1.2 MByte) ● Printer ● Keyboard 	<p>Uses Hewlett Packard and Computer/Processor.</p> <p>Hardware for Map Interface Available within 1.5 Years</p>	Current Model Redesigned within the Last Six Months	\$143,750 (Quotation No. 2413, 2414, 2415)
VIEW ENGINEERING	X-Y ± .0016 Z ± .0025 @ 68°F + 22°	<ul style="list-style-type: none"> ● 1 MByte Memory ● 12" CRT ● 2 Flexible 5 1/4" Disk Drives (680k) ● 10 MByte Winchester Disk ● Printer ● Keyboard 	<p>Uses Custom View Processor Based on Intel Multibus.</p> <p>Map Hardware Available Today</p>	Fourth Year in Production GM Owns 30% of Company	Approximately \$170,000 (150K Base Price Plus Options)
REMARKS	Thermal Errors of Rank System if Operated Over View Spec Could be as Large as .002-.003 Inches		Map Interface with ITM-Project 12 Host Computer is a System Requirement	View Will Support ITM Project Technically Due to GM Partnership	Based on Equivalent Options and Standard Equipment Available

700941

Figure 8

5.2

ROBOT

At the time this survey was performed only two vendors manufactured a robot with an advanced controller design: GMF Robotics and ADEPT. Unlike other manufacturers controllers these featured self-diagnostics, full program and edit capability, menu driven software, analog and digital I/O capability, and high level programming languages. At the time the robot selection was being addressed there existed two applications. One for material handling, and the second for thread inspection. ADEPT'S design lent itself only to thread inspection while GMF'S product line could support both. (ADEPT built only one robot at that time.)

If thread inspection were to become a reality it would be desirable to have common equipment. For this reason GMF'S S-100 robot and Karel controller were selected. This robot was designed for use as a material handling platform. However, for development purposes it could be used on an interim basis for determining if thread inspection end-of-arm-tooling was robot compatible.

5.3

SIX-AXIS FORCE SENSOR

At the time this survey was performed only three vendors were manufacturing six-axis force sensors. These were:

Barry Wright Corp.
700 Pleasant St.
Watertown
Mass. 02172
Model FS6-120A

Lord Corp.
407 Gregson Dr.
Cary
N. Carolina 27511
919-469-2500
Model F/T-15/50

JR INC
22 Harter Ave. #13
Woodland
CA. 95695
Model VFS-3A15

All these devices are similar in construction and are specifically made for robotic applications. They are based on strain technology and allow the user to monitor force and torque reactions in + or - X,Y and Z directions, hence six axes. Generally all units are available in varying levels of sensitivity, however for our application, due to the delicate nature of thread gaging, a resolution of .05 in -oz in torque was desired. At the time all vendors were advertising a .15 - .20 in-oz resolution. Another feature absolutely required for laboratory testing was an analog

output capability. After reviewing these requirements with suppliers, all felt they could fine tune an off-the-shelf unit to meet the torque sensitivity requirements. However, only JR3 could supply the analog output at no extra charge. For this reason the JR3 force/torque sensing system was selected.

5.4 SYSTEM SUPERVISORY COMPUTER (SSC)

Selection of the SSC was facilitated through use of an evaluation matrix, which was designed to aid in the comparison of several candidate systems. The selection issues used for comparison included:

- system bus standard
- system CPU type
- type of system memory
- operation systems supported
- available programming languages
- data communications interfaces
- DSO experience with candidate system
- type and availability of training
- availability of maintenance support
- price
- vendor's ability to deliver
- overall match with project needs

The vendors considered were:

- Digital Equipment Corporation
- Hewlett Packard
- Intel
- Motorola
- International Business Machines

Additionally, it was required that the hardware and software solutions be implemented by using of-the-shelf products. An intangible factor, best described "as the perceived ability and willingness of the vendor" to help satisfy project goals throughout the life of the project, also entered into the final selection. The system selected was the Intel 310 microcomputer.

6.0 EQUIPMENT SPECIFICATIONS

6.1 DIMENSIONAL INSPECTION MACHINE

The View Engineering Model 1200 (Figure 9) is a 3 - dimensional non-contact measuring system. It has a working envelope of 18 x 24 x 6 (X,Y, Z) inches in addition to a fourth rotational axis that was originally designed to mount and turn symmetrically manufactured (Lathed) parts. The system is delivered with four lenses (16mm, 38mm, 50mm, 75mm) allowing the user to select an operating accuracy depending on the application involved. Using the system's most accurate lens a system accuracy of .0004 inches in X,Y and Z axes can be attained. See Figure 10 for other available accuracy specifications.

The system utilizes an X - Y servo-motor-driven table with a camera mounted in the Z-axis. Since the X and Y dimensions are in the same plane, the planar dimension is established by the distance the table travels plus the camera's interpretation of the edge of the surface feature being inspected. A built-in algorithm establishes the planar dimension that has been checked. The dimension along the Z-axis is a function of the focal length of the camera. One plane is established as the zero or reference point, with the depth being a new plane requiring a new focal length. The distance the fixed focal length camera moves along a Z axis determines the Z dimension of the part feature being examined. Lens selection is determined by part feature tolerances to be inspected. Because each lens has a different field-of-view (.01 to .20 in.) and the system is preprogrammed to move to a nominal location to acquire an image (edge of feature), it is necessary to match the field-of-view with the allowable part variance (due to part tolerance). Search routines do exist, to a limited degree, to "look" for the feature outside the field-of-view. Since the vast majority of mechanical parts produced at Delco are more critically toleranced, all testing performed used the most accurate lens (16mm.)

6.2 ROBOT

The GMF S100 Robot selected is a six-axis anthropomorphic device manufactured for material handling and medium accuracy assembly applications (see Figure 11 for Illustration: Manufacturers Specifications). It's unique human-like configuration allows it to operate in both spherical and cartesian coordinate systems. Optional equipment included a 16 channel A/D converter card for use in digitizing force sensing electronics.

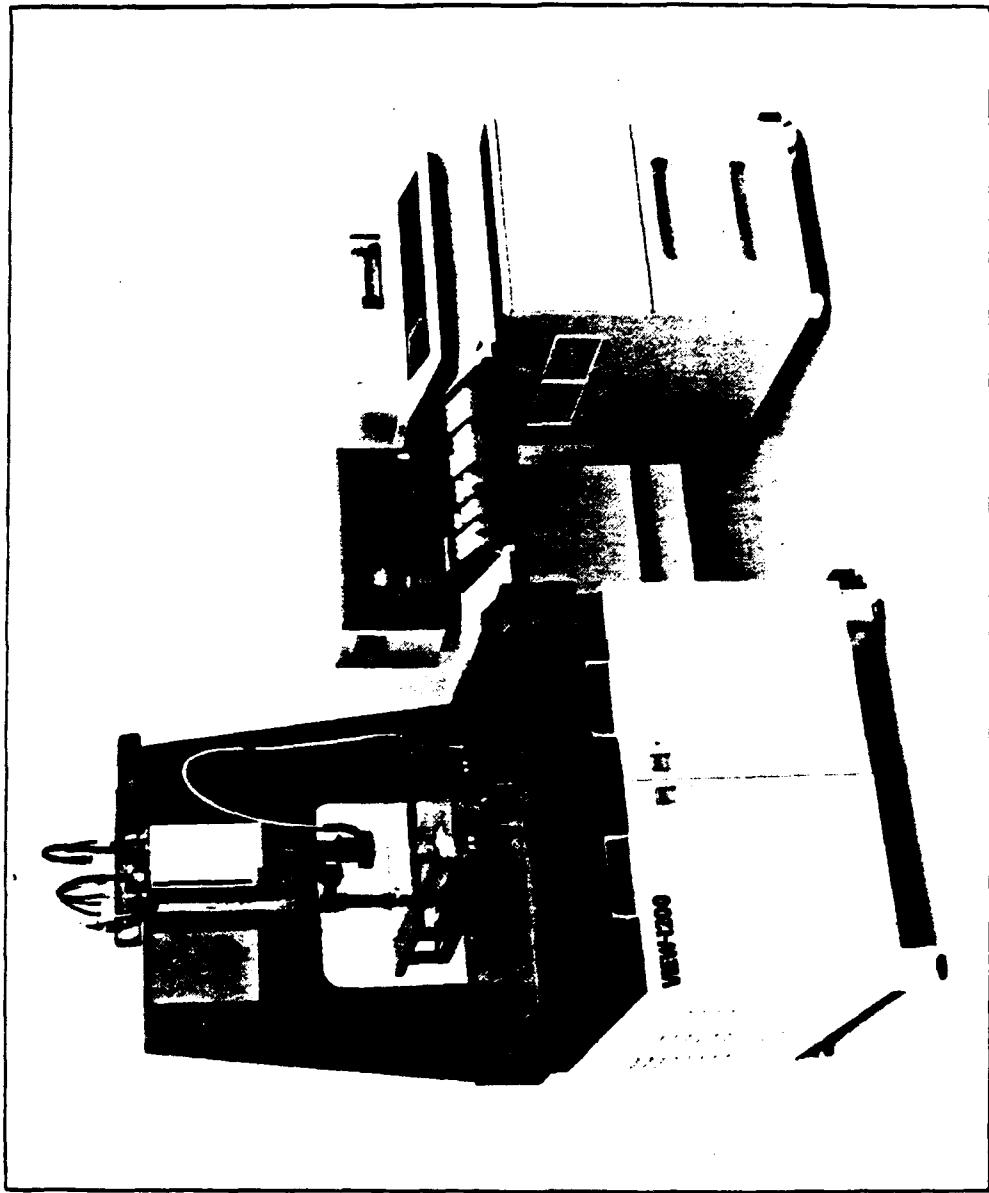

VIEW 1200

Figure 9

VIEW 1200 ACCURACY SPECIFICATIONS

LENS FOCAL LENGTH	X & Y AXIS			Z AXIS (All)
	12 x 12	12 x 18	18 x 18	
18mm	±0.00016 in	X - ±0.00016 in Y - ±0.00040 in	±0.00040 in	±0.00025 in*
34mm	±0.00025 in	X - ±0.00025 in Y - ±0.00050 in	±0.00050 in	**
50mm	±0.00042 in	X - ±0.00042 in Y - ±0.00066 in	±0.00066 in	**
75mm	±0.00066 in	X - ±0.00066 in y - ±0.00090 in	±0.00090 in	**

* Determined using Starrett-Weber CROBLOX gage blocks.
 ** Accuracy with other lenses depends on optical depth of focus.

700942

Figure 10

GMF S100 ROBOT

DIMENSIONS

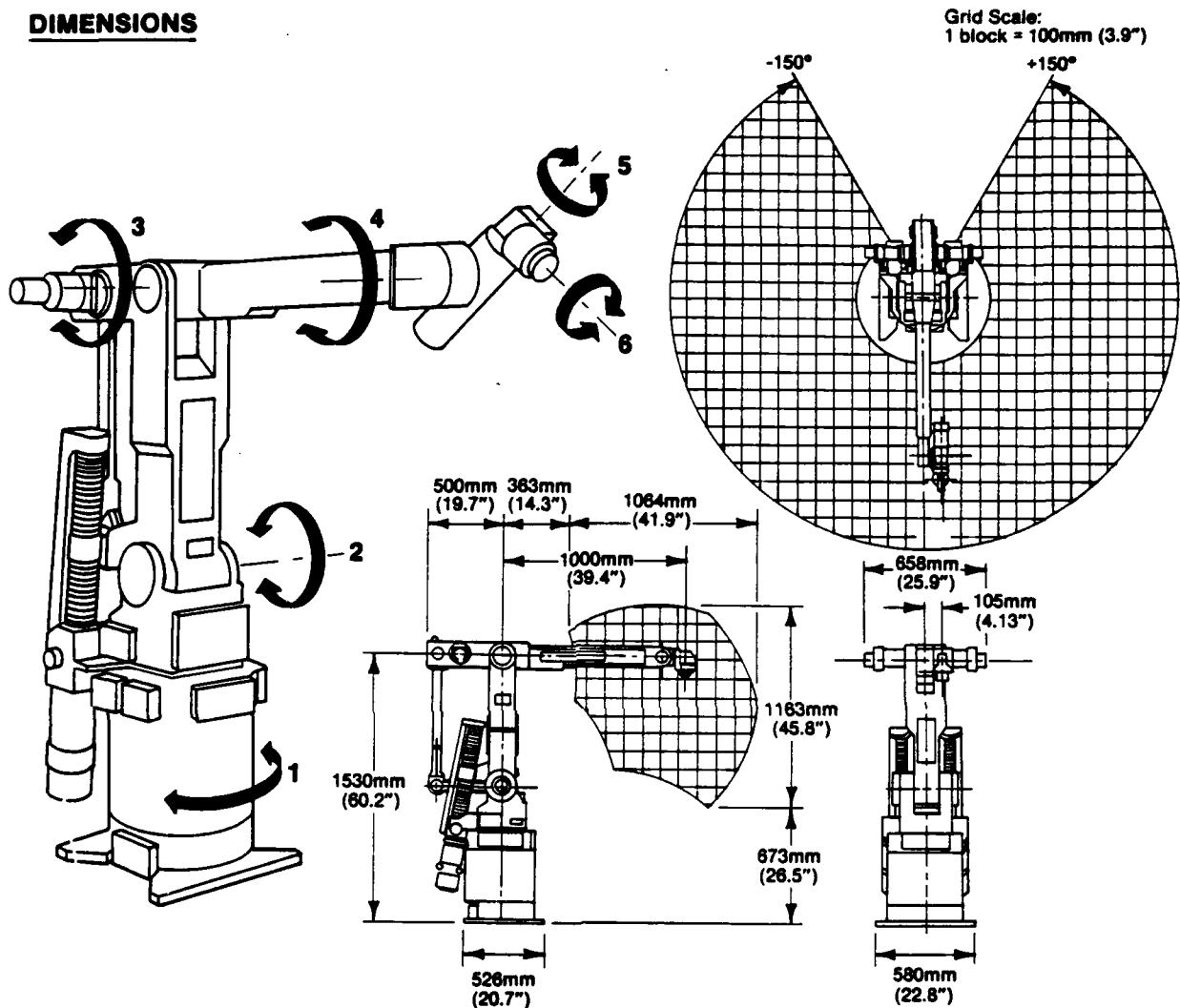

CAPACITIES

Loading capacity at wrist mounting surface at maximum speed and extension:

6-Axis Model:
Standard type: 10kg (22 lbs)
High Speed Type: 5kg (11 lbs)

5-Axis Model: 10kg (22 lbs)

Repeatability: $\pm 0.2\text{mm}$
($\pm 0.008\text{"}$) at maximum speed and extension

Approximate weight:
Mechanical unit = 350kg (770 lbs)

6-AXIS MODEL

AXIS DESCRIPTION

- | AXIS DESCRIPTION | RANGE |
|-------------------|-------|
| (1) Base rotation | 300° |
| (2) Waist bend | 85° |
| (3) Shoulder bend | 65° |
| (4) Wrist pitch | 190° |
| (5) Arm roll | 360° |
| (6) Wrist roll | 340° |

RANGE

SPEED

Standard High Speed

- | Standard | High Speed |
|--------------|--------------|
| 90° per sec | 90° per sec |
| 90° per sec | 90° per sec |
| 90° per sec | 90° per sec |
| 120° per sec | 240° per sec |
| 120° per sec | 240° per sec |
| 120° per sec | 300° per sec |

5-AXIS MODEL

- | | |
|-----------------|------|
| (4) Wrist pitch | 250° |
| (5) Wrist roll | 380° |

- | |
|------|
| 250° |
| 380° |

- | |
|--------------|
| 240° per sec |
| 380° per sec |

Figure 11

700943

SIX-AXIS FORCE SENSOR

The JR3 Force Sensor selected (Model UFS-3A15, see Figure 12) was a specially modified off-the-shelf device. Modifications made at the factory enhanced the system's resolution from 0.15 in-oz to .05 in-oz. otherwise, the system's specifications are as follows:

- JR3 monolithic six-degree-of-freedom force sensor
- sensor cable (connects JR3 sensor to JR3 electronics enclosure)
- JR3 Intelligent Support System (JR3 sensor to JR3 electronics enclosure which contains):
 - signal conditioning board
 - data acquisition board
 - processor board

Foil strain gages on the JR³ sensor body are excited by voltage through the sensor cable from the electronics enclosure. Millivolt analog signals from the sensor are carried back to the electronics enclosure via the sensor cable. The sensor cable's foil shielding is driven at a guard voltage to increase noise rejection.

The JR³ signal conditioning board amplifies and filters the raw analog signals, then transmits them to the JR³ data acquisition board where the signals are digitized (12 bit A/D). Digital data is then transmitted to the JR³ processor board, processed (cross sensitivity removal, digital filtering, load envelope monitoring, tare weight removal, etc.) and made available for output. The processor board also watches for, and acts upon, input commands. The six channels of un-decoupled analog signals are also output through a nine-pin port.

Onboard shunt resistors combined with full scale checking/calibration software offer automatic drift compensation upon the receipt of the proper command.

The JR³ sensor requires the power supplies listed below. Each is shown with the particular portion of the electronics it powers.

+5V	2A	digital power (microprocessor, etc)
+15V	300mA	analog power (bridge amplifiers, reference voltages, etc.)
-15V	300mA	analog power
+12V	75mA	serial communication, shunt relays
-12V	75mA	serial communication

The six channels of analog outputs are in the ± 10 volt range with +10 volts at +100% of full scale load and -10 volts at -100% of full scale load. Within a certain range, the user may set the desired full scale values via gain adjust. Setting the full scale

JR3 UNIVERSAL FORCE-MOMENT SENSOR SYSTEM

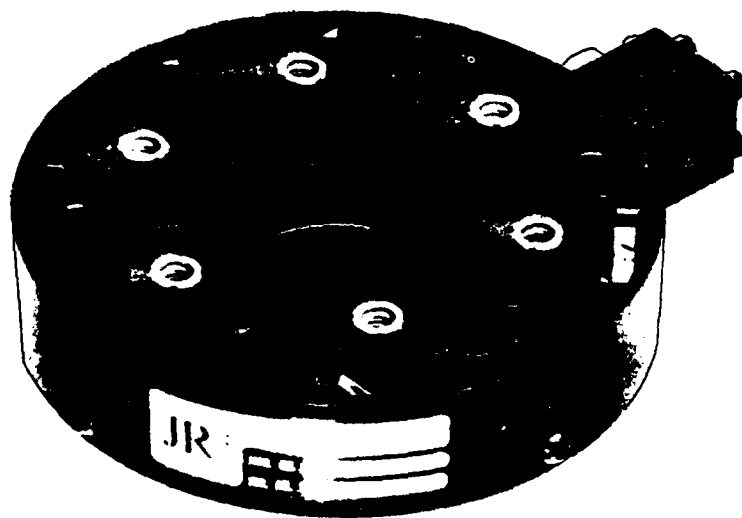
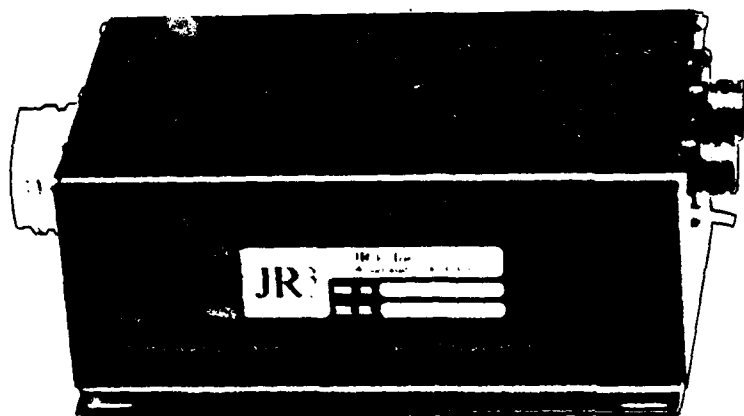

Figure 12

for larger loads allows the user to read overloads; setting the full scale for smaller loads enhances resolution.

The discrete I/O port consists of:

- eight discrete bits of input: four are used to enable load envelopes; one triggers a soft reset; one resets the offsets; and one is not currently used.
- eight bits of output - seven user-definable flags for load envelope trip points and error flag plus the safety strobe.
- hard reset - hardware reset of processor.
- digital ground.

Two RS232 serial ports are provided (port A & B) which can be used for inputting commands, data transmission, error monitoring, threshold monitoring, etc. Data format through each serial port is controlled by commands entered through that port. The only difference between ports A & B is that port B will begin a baud rate detection routine upon receipt of a "break" signal; port A ignores the "break" signal. Default serial communication parameters (from factory) on powerup are: 9600 baud, 8 data bits, no parity, 1 stop bit.

6.4 SYSTEM SUPERVISORY COMPUTER (SSC)

6.4.1 SSC HARDWARE

The system selected to function as the system supervisory computer is an Intel system 310 microcomputer. Its characteristics include:

- a seven slot card cage, suitable for addition of various data communications controller boards
- an 80286 based, 16 bit processor
- multi-user and multi-tasking capability
- priority interrupt logic
- hardware system clock
- 1 megabyte of RAM storage
- 1 parallel port connector
- 2 serial port connectors
- 1 flexible 5-1/4 inch double sided, double density disk drive
- 1 40 megabyte Winchester disk drive

The Intel system 310 has proven to be compatible with all SSC oriented project requirements.

6.4.2 SSC SOFTWARE

The operating system selected was Intel's iRMX 86. It's major features include:

- real-time capability
- concurrent running of multiple tasks
- priority-based scheduling
- interrupt-driven processing
- device-independent I/O capability

The iRMX 86 operating system is configurable through use of a supplied interactive configuration utility program. Various programming languages were available, and PL/M-86 was selected for project use. PL/M-86 is a high-level, block structured language which has many useful features.

7.0 ENABLING TECHNOLOGY DEVELOPMENT

This section of the report will primarily address testing as related to thread inspection and material handling. Because the vision system used for dimensional inspection was an off-the-shelf technology no enabling technology testing was required in this area. Some material handling concepts were tested as related to group technology and will be discussed in lesser detail. The results of these experiments would be used to further solidify the inspection cell's final configuration.

7.1 THREAD INSPECTION (INTERNAL)

7.1.1 BACKGROUND

Gaging of internal screw threads is the process of investigating the extent to which they conform dimensionally to prescribed limits of size. This inspection process is accomplished using go and no go gaging that is physically threaded into the product thread.

The maximum-material-limit, or go gage, verifies the extent of the tolerance as applied to a specific thread in the direction of the limit of maximum material and represents the minimum limit of internal threads. The ideal go gage is a threaded counterpart of the internal thread, made exactly to its prescribed dimensions. These gages most nearly duplicate the assembly conditions of threads.

The minimum-material-limit gages, or no go, control the extent of the tolerance in the direction of the maximum limit of internal threads. Again it is a threaded counterpart of the internal thread, however does not represent assembly conditions.

The application and maintenance of thread gaging is defined in FED-STD-H28. In short the usage of thread gaging to verify product conformance is very subjective. Because it is not practical, or possible, to control nor limit the torque applied by operators, or even that used by a specific operator at various times and under varying conditions, the following standard practice has been adopted with respect to permissible gage entry:

Go gages must completely enter the product internal thread provided a definite drag from contact with the product material does not result.

No Go Gages acceptability is applied to the product internal thread if it does not enter, or if a definite drag from contact with the product material results on or before the third turn of entry. Obviously the term "Definite Drag" is subjective and will vary from operator to operator.

7.1.2 TESTING

In order to develop an automated thread inspection process, it was necessary to determine quantitatively what the "Definite Drag" limit would be for each thread size. Using internally threaded samples (steel and aluminum) mounted to the JR³ force/moment sensor, inspection operators normally assigned thread inspection tasks were tested. Each operator "inspected" three samples each of 2-56, 4-40, 6-32, 8-32, 10-32, 1/4-20 and 1/4-28 size threads (see Figure 13). Class III threads were chosen to obtain a worst case situation and all testing was conducted with go gaging only. It was assumed that definite drag limits would be independent of gage type. During each sample test, running torques as well as stall torques were obtained using the JR³ sensor analog output and a strip chart recorder. In all 27 samples for each thread size and material type were tested. Running torque data from a typical test run is shown in Figure 14 and variations in technique are apparent. Some operators continually turn the gage with both hands while others use only one hand. This can be observed by comparing running torque amplitude variations. It is also apparent from the data (Figure 15) that stall torque (Definite Drag) differences did exist between operators. Averaged Torque values vs. gage size are represented in Figures 16 thru 24 for aluminum and Figures 25 thru 33 for steel, for each of the participating operators. A summary of these curves is presented in Figures 34 and 35. From this data desirable torque thresholds required for automating Go/No Go Gaging procedures were derived. This data is presented in Figure 36 and served as a guideline throughout the thread inspection end-of-arm-tooling design phase.

7.2 MATERIAL HANDLING

Efforts concentrated on designing and testing end-of-arm tooling (EDAT) concepts capable of holding and/or transporting families of similar parts from input stations to the View 1200 where dimensional inspection would occur. The object was to identify concepts and designs that would minimize tooling requirements primarily at the View 1200 thereby further increasing the cost payback of the proposed automated system.

As mentioned earlier the View 1200 is equipped with a fourth rotational axis. Though it was intended by the manufacturer to hold and orient lathed parts, the concept of adding a robotic gripper capable of fixturing a part seemed a more desirable solution. (See Figure 37). To successfully implement the transport and fixturing concept on an open-loop basis (no feedback) two conditions had to be met. First the gripper must be capable of handling a family of parts, not a unique part, and second it must transport them to the View 1200 with sufficient accuracy to place the part within the vision systems field of view ($\pm .005$).

TORQUE THRESHOLD TEST SETUP

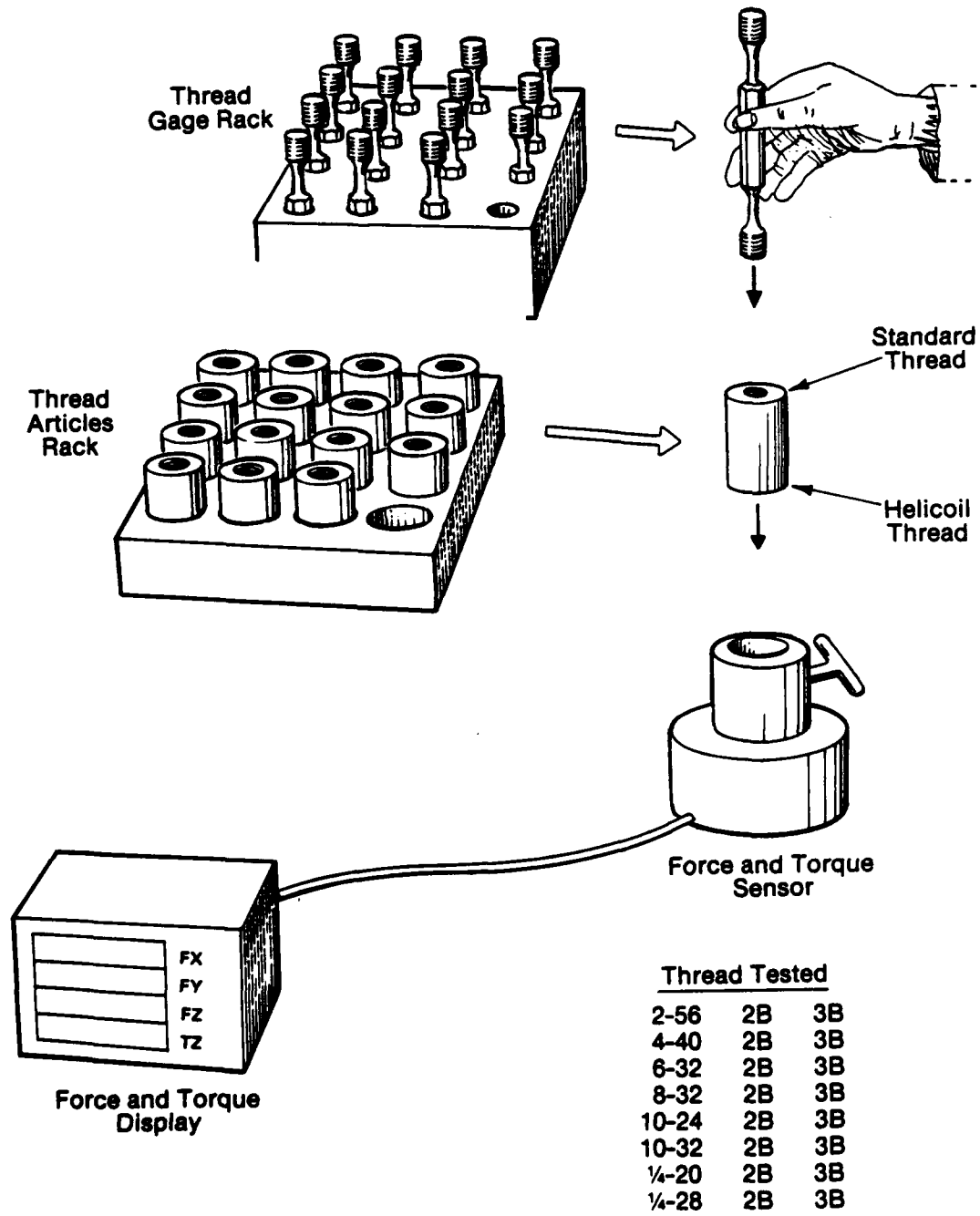

501335

Figure 13

OPERATOR TEST DATA

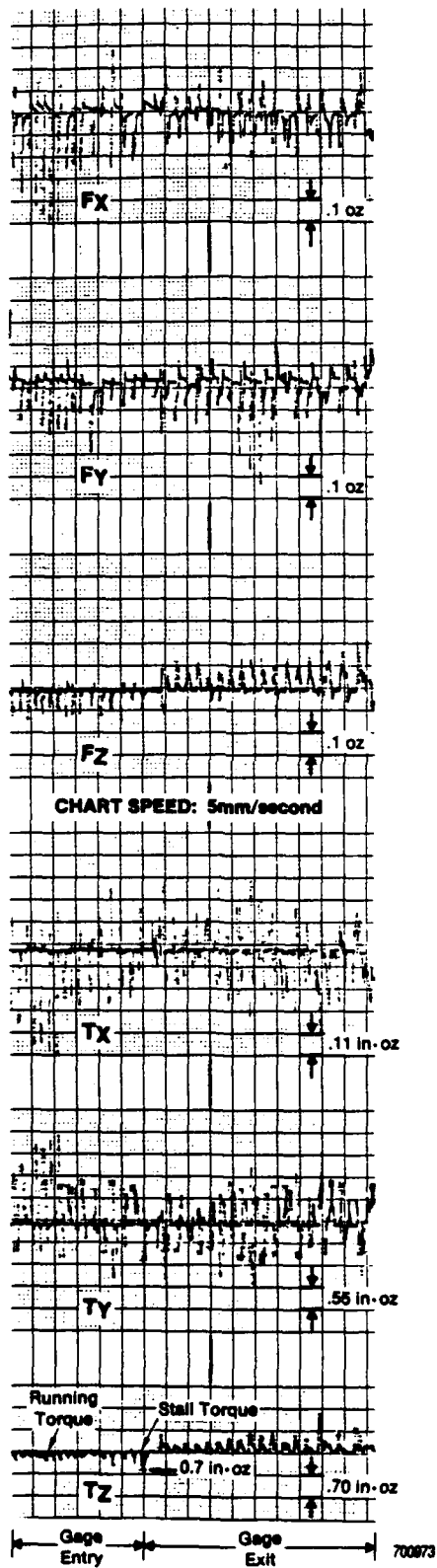

Figure 14

OPERATOR TEST DATA

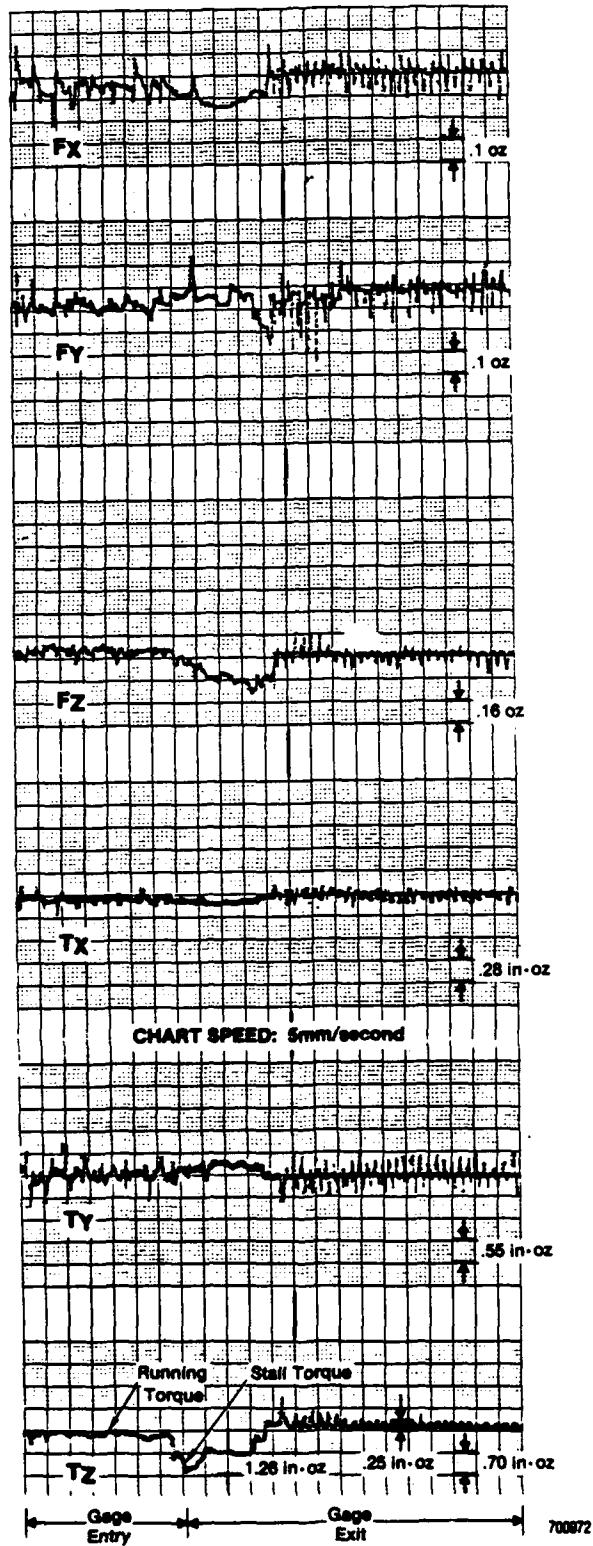

Figure 15

TORQUE VERSUS GAGE SIZE NO.1
(Aluminum Sample)

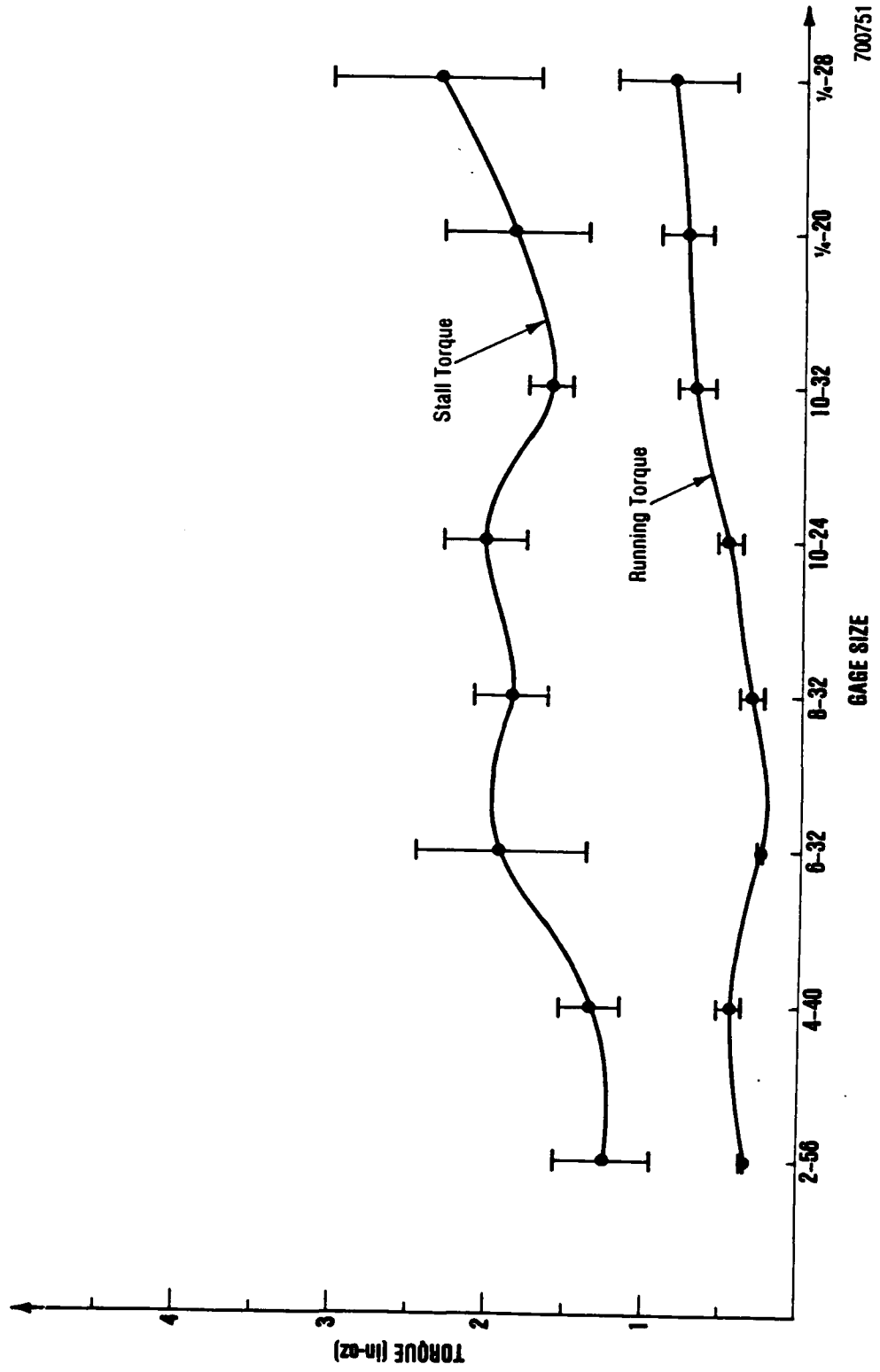
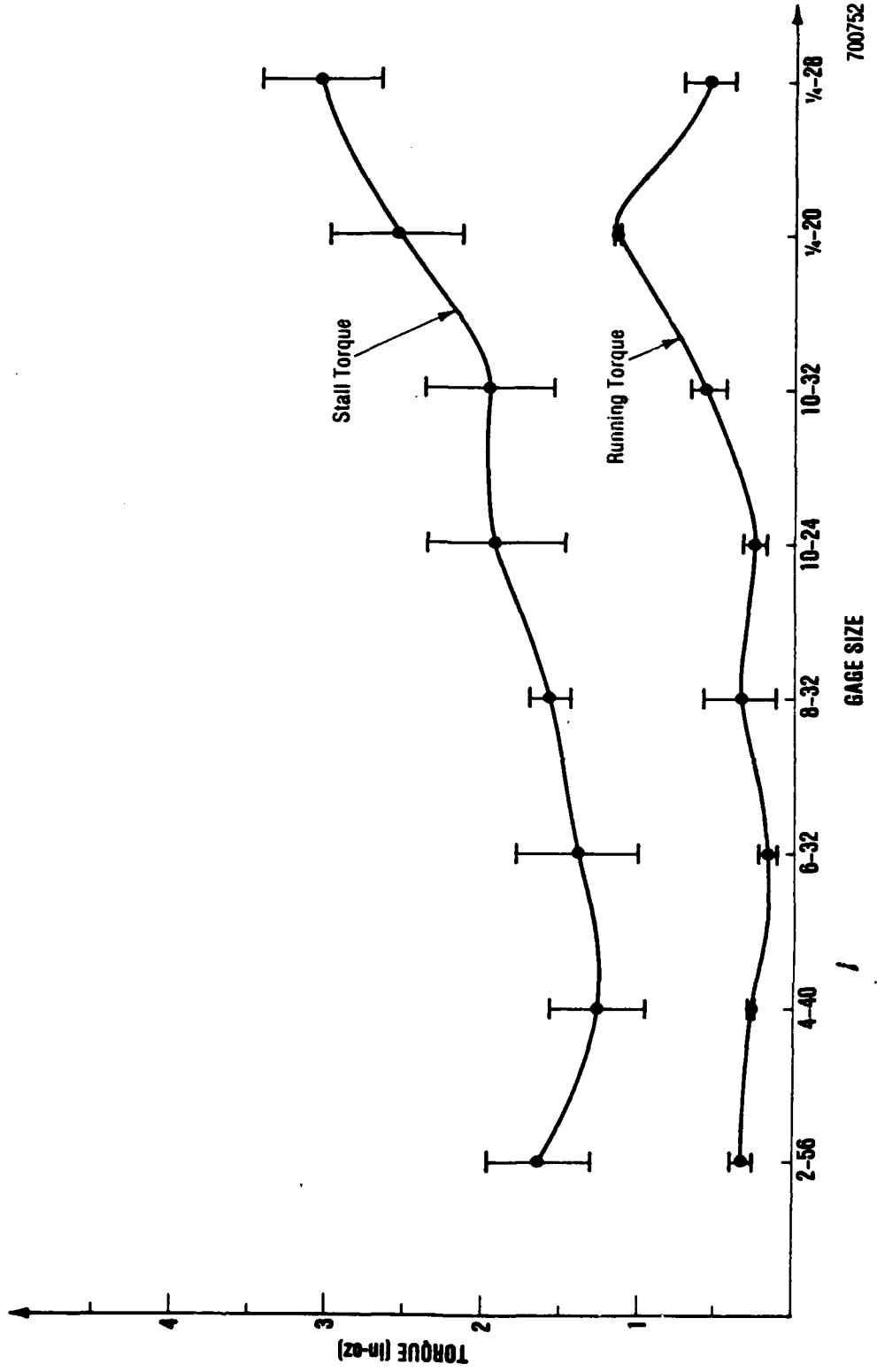

Figure 16

**TORQUE VERSUS GAGE SIZE NO.2
(Aluminum Sample)**



700752

Figure 17

**TORQUE VERSUS GAGE SIZE NO.3
(Aluminum Sample)**

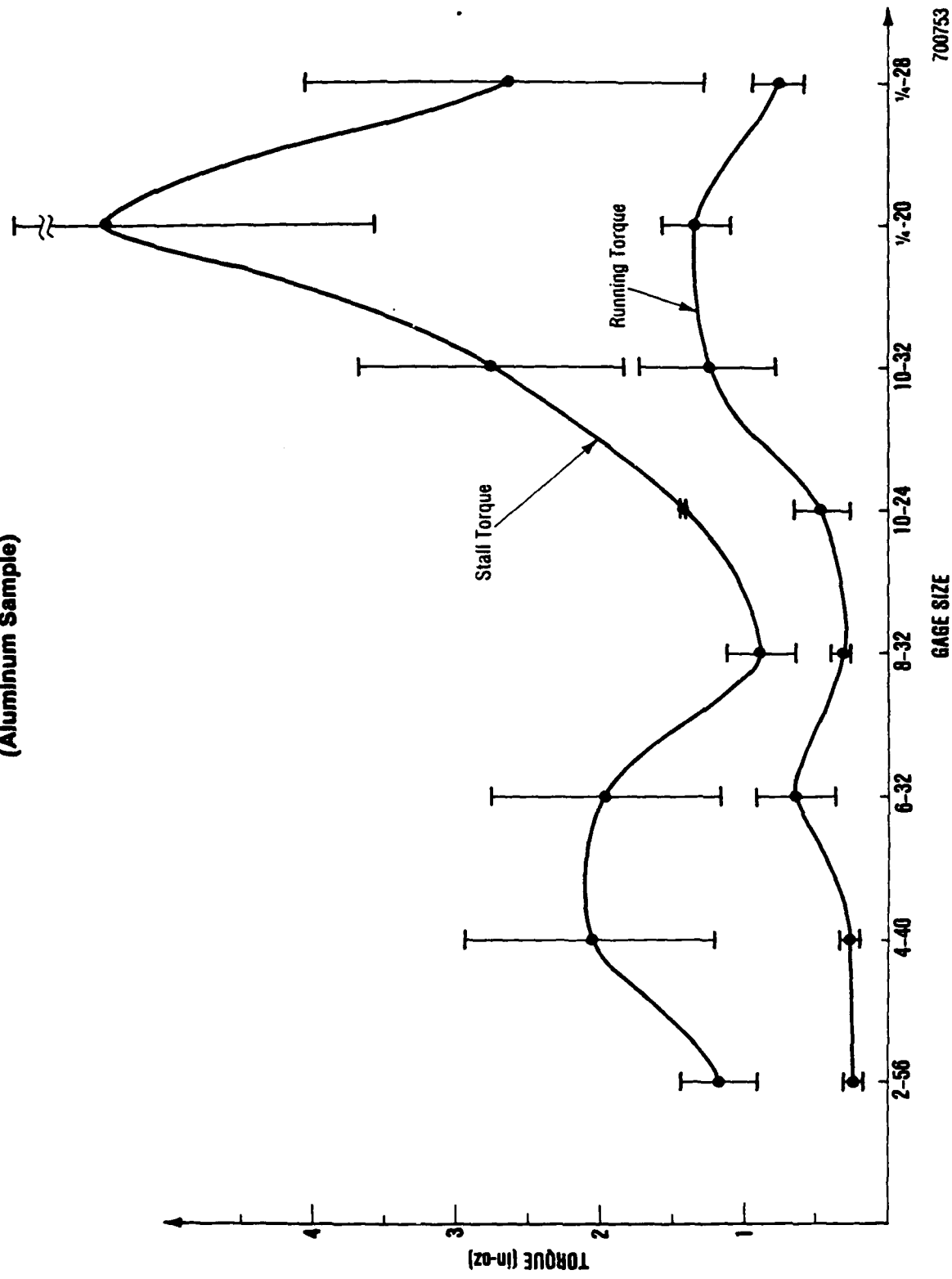
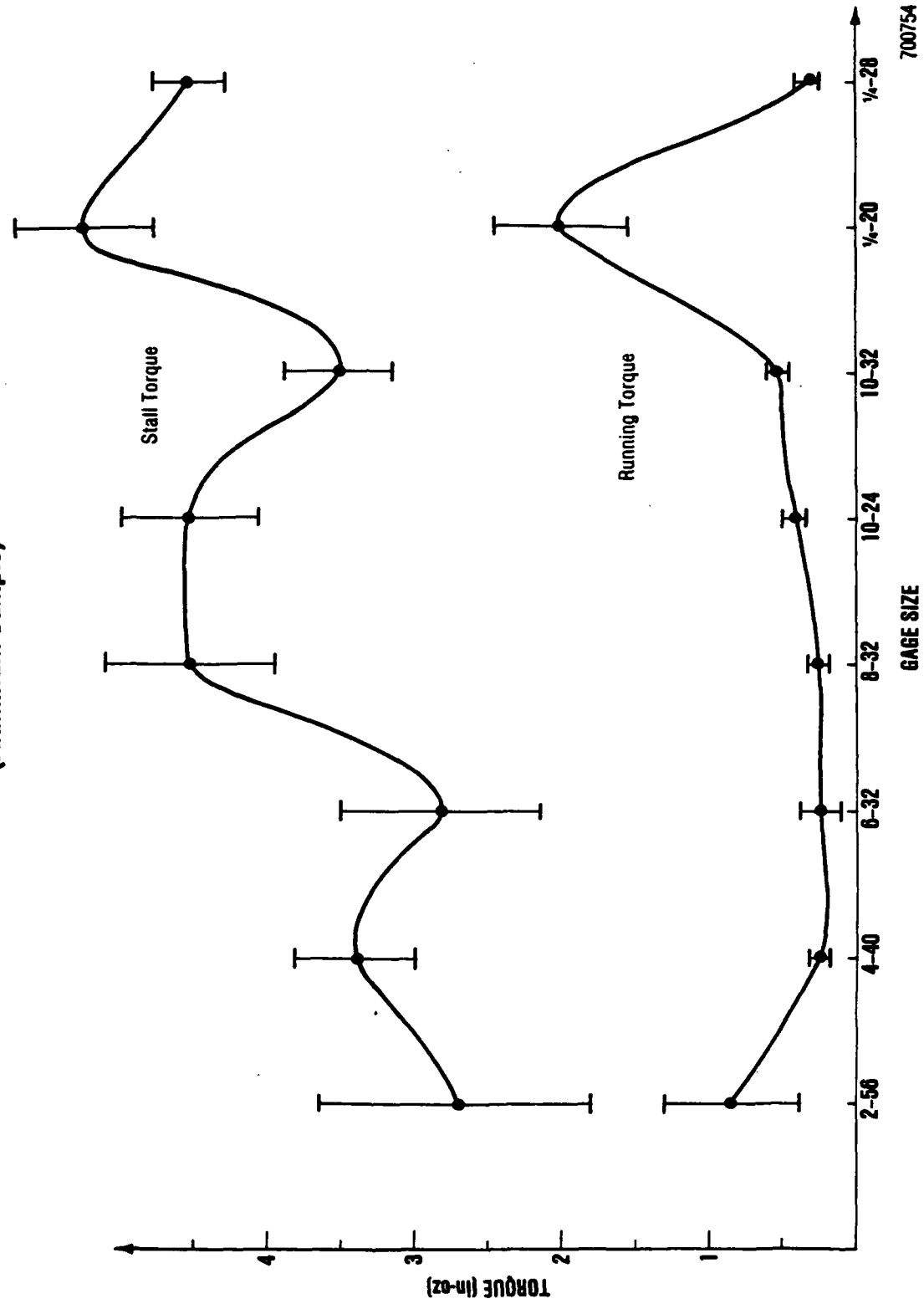

Figure 1b

**TORQUE VERSUS GAGE SIZE NO.4
(Aluminum Sample)**



700754

Figure 19

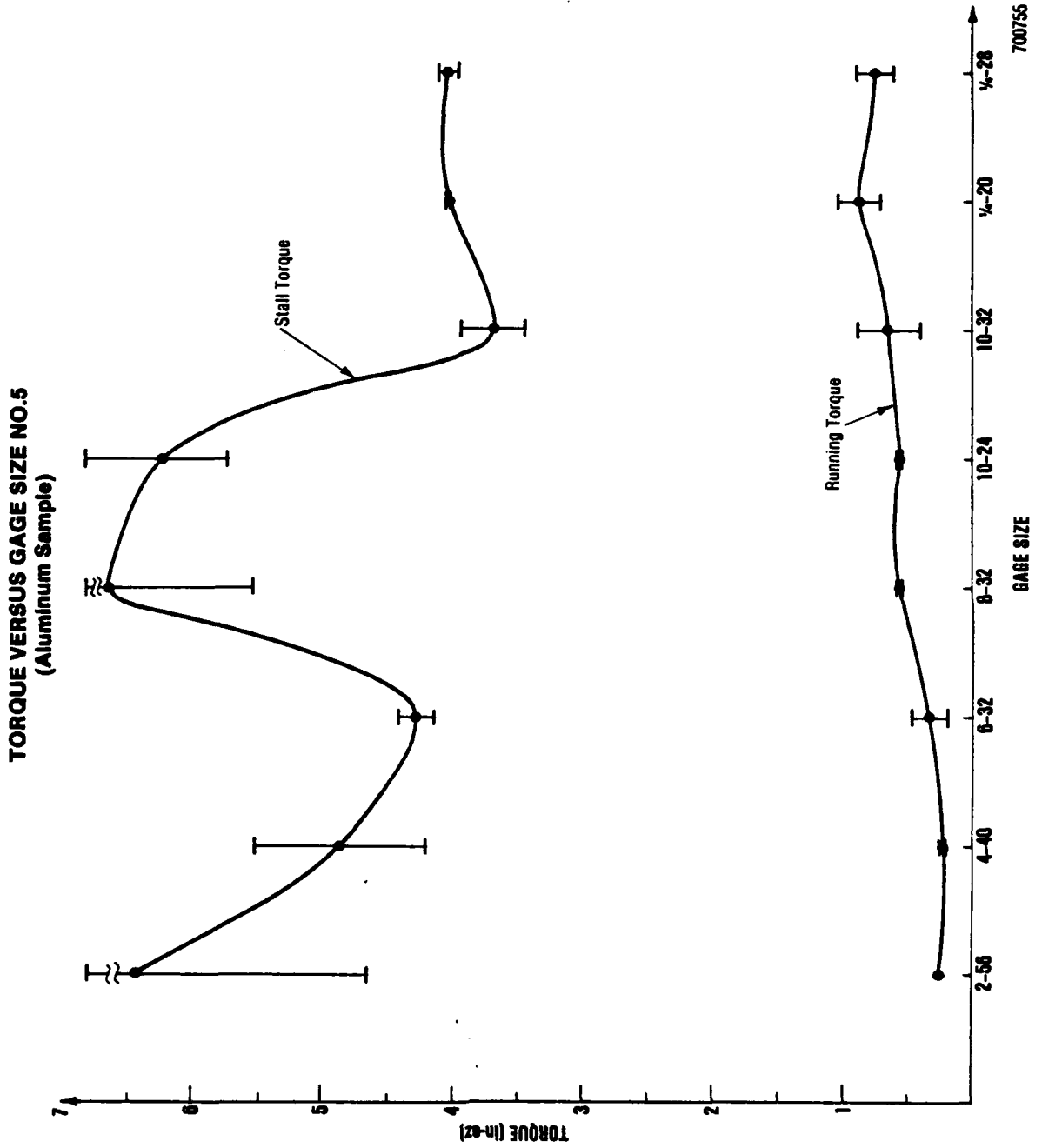

Figure 20

**TORQUE VERSUS GAGE SIZE NO.6
(Aluminum Sample)**

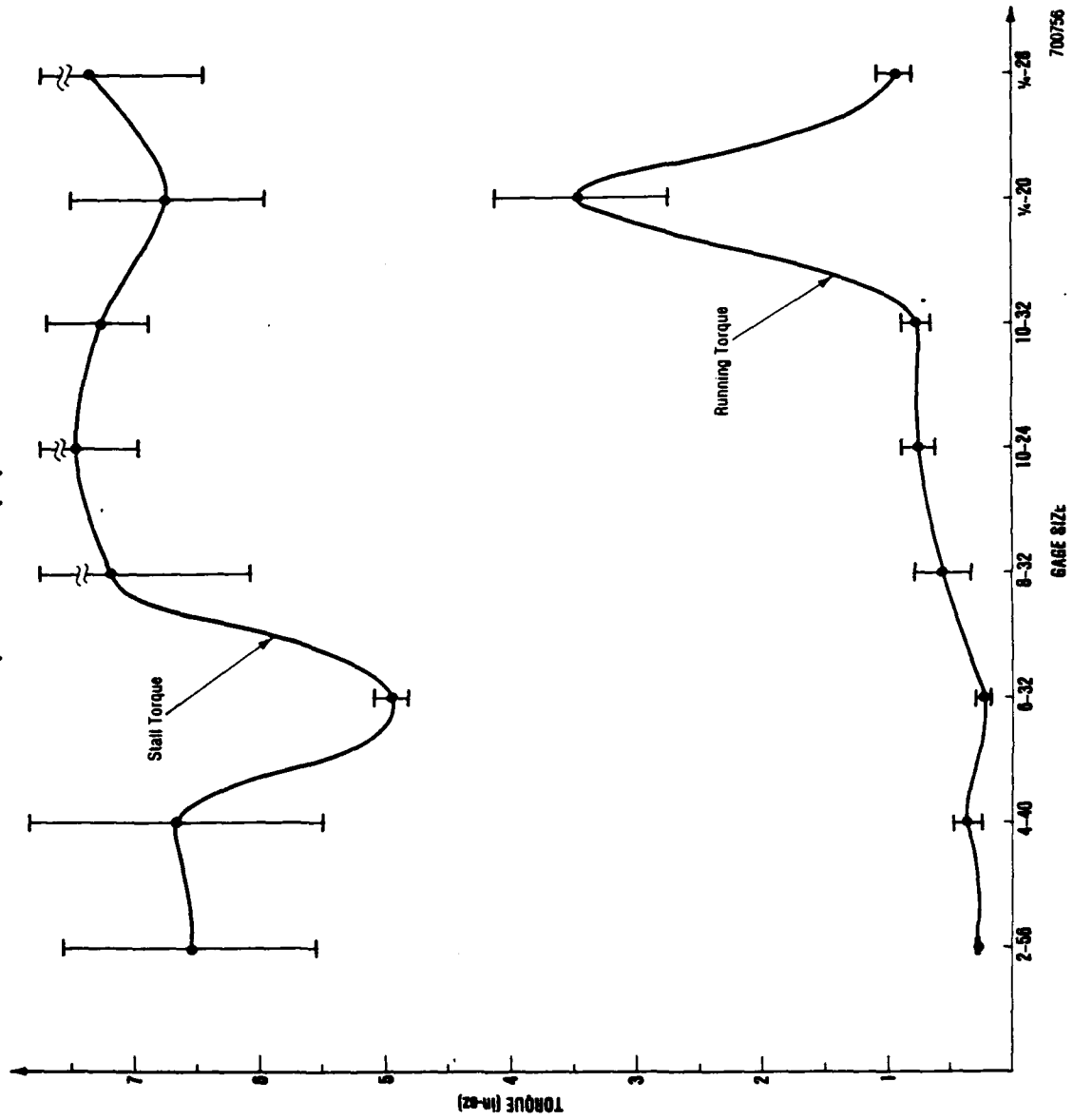

Figure 21

**TORQUE VERSUS GAGE SIZE NO.7
(Aluminum Sample)**

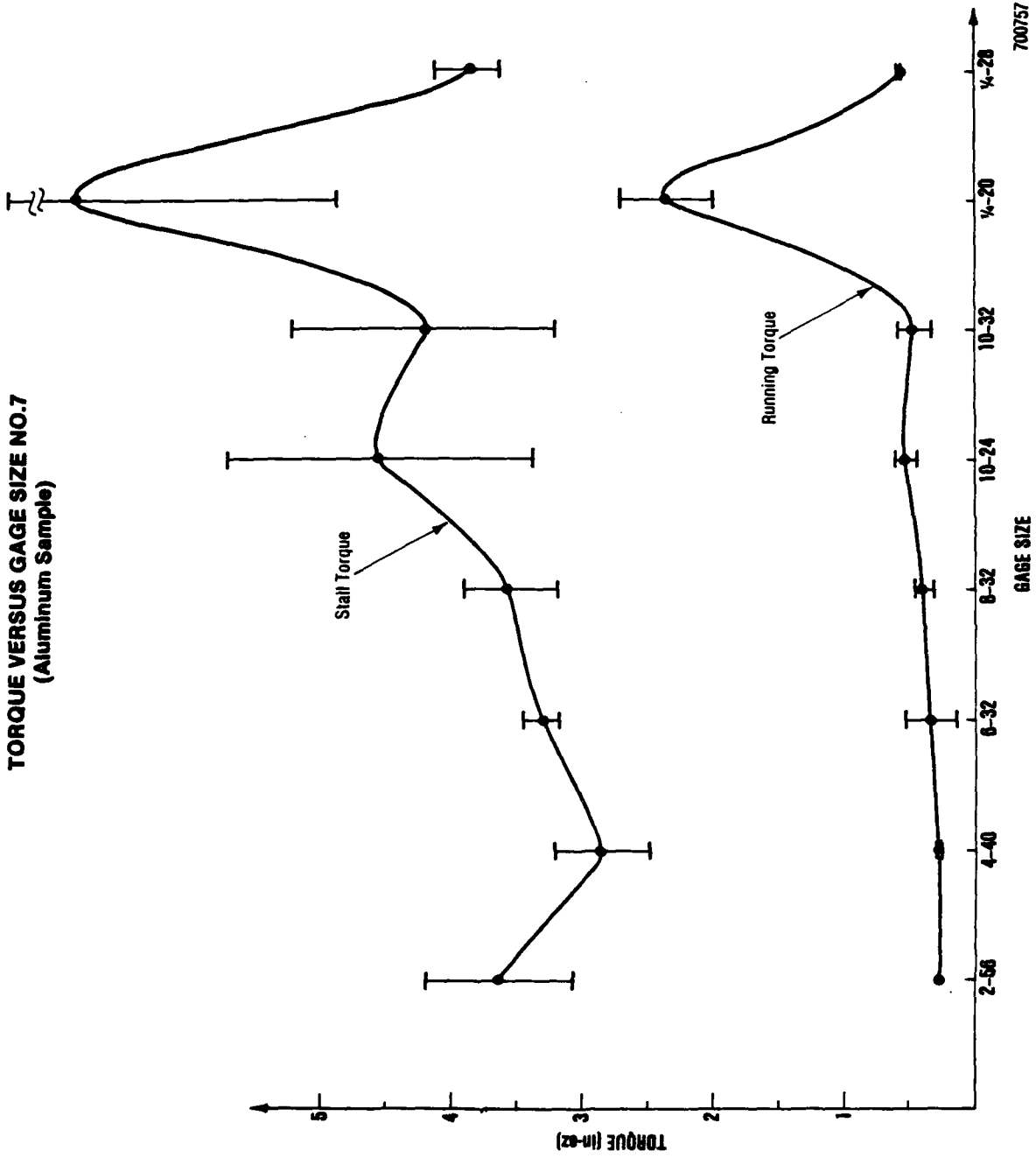

Figure 22

TORQUE VERSUS GAGE SIZE NO.8
(Aluminum Sample)

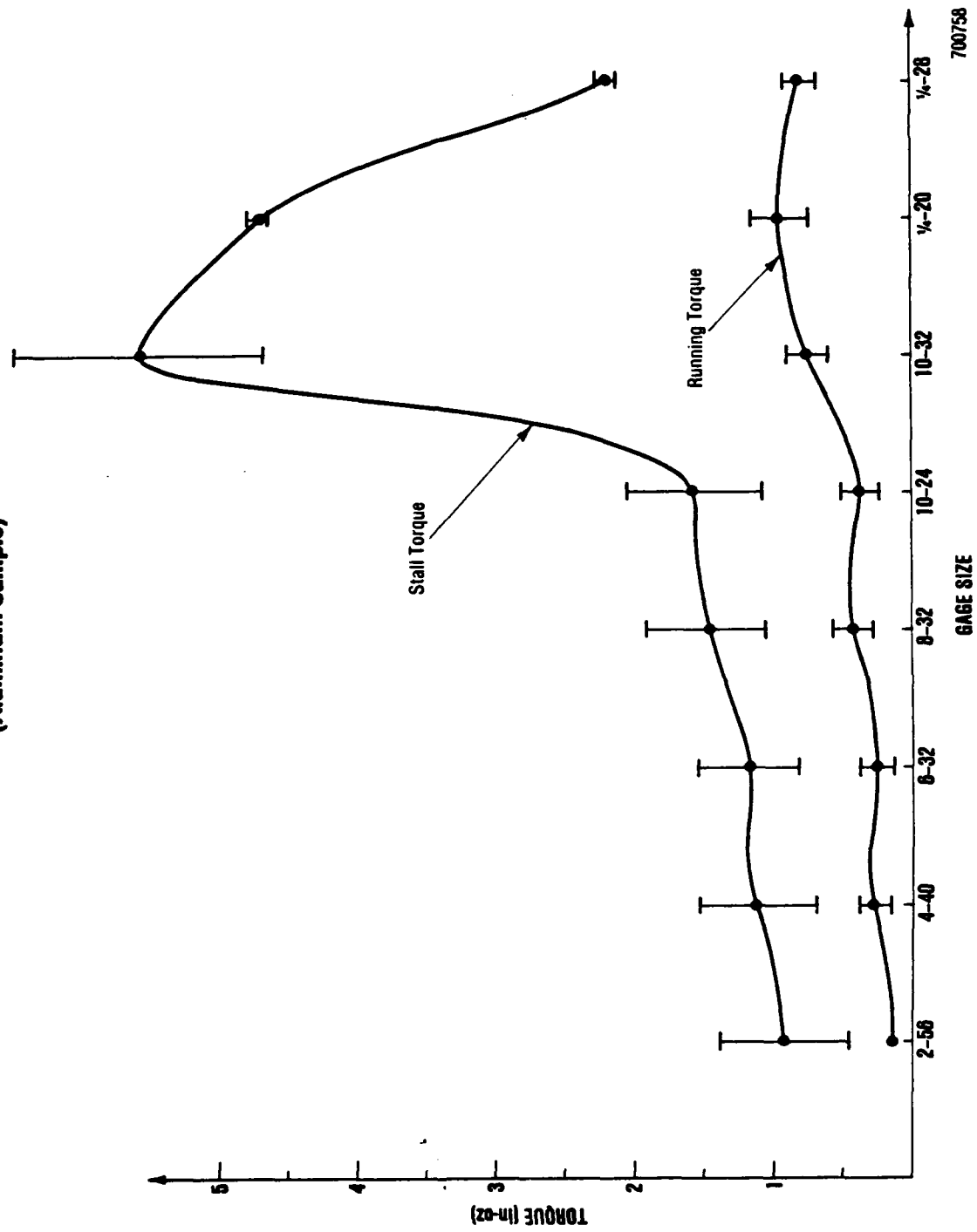

Figure 23

TORQUE VERSUS GAGE SIZE NO.9
(Aluminum Sample)

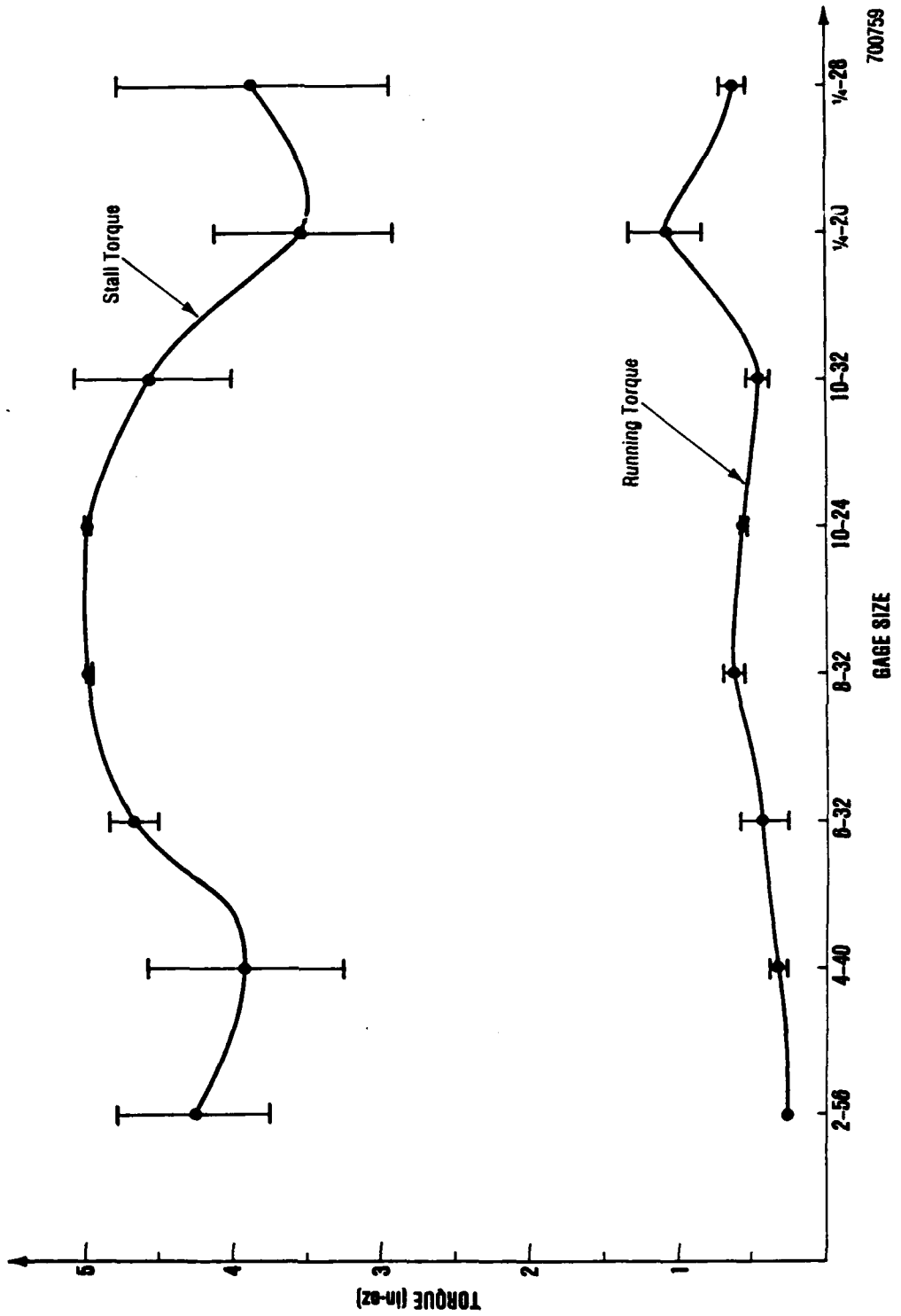
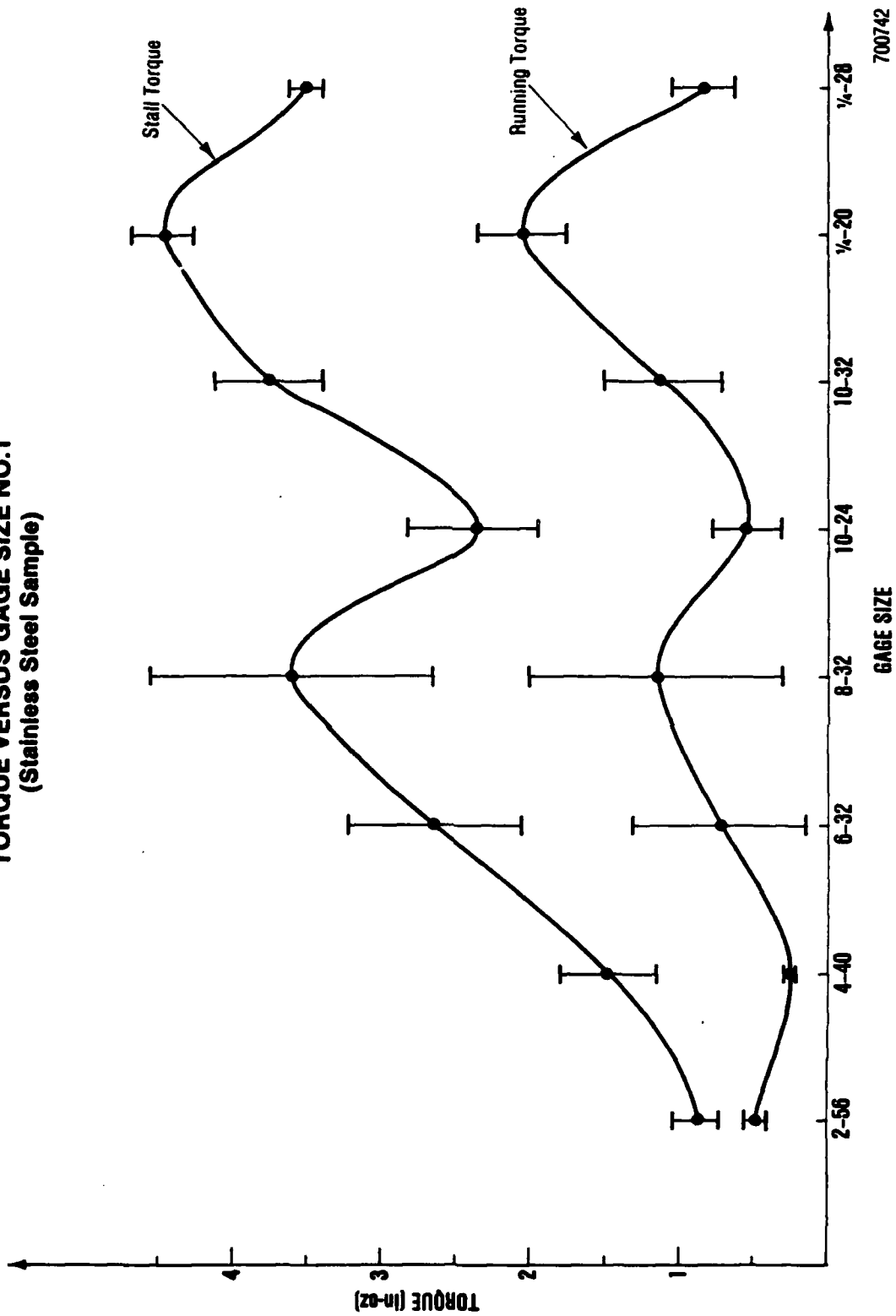

Figure 24

TORQUE VERSUS GAGE SIZE NO.1
(Stainless Steel Sample)



700742

Figure 25

TORQUE VERSUS GAGE SIZE NO.2
(Stainless Steel Sample)

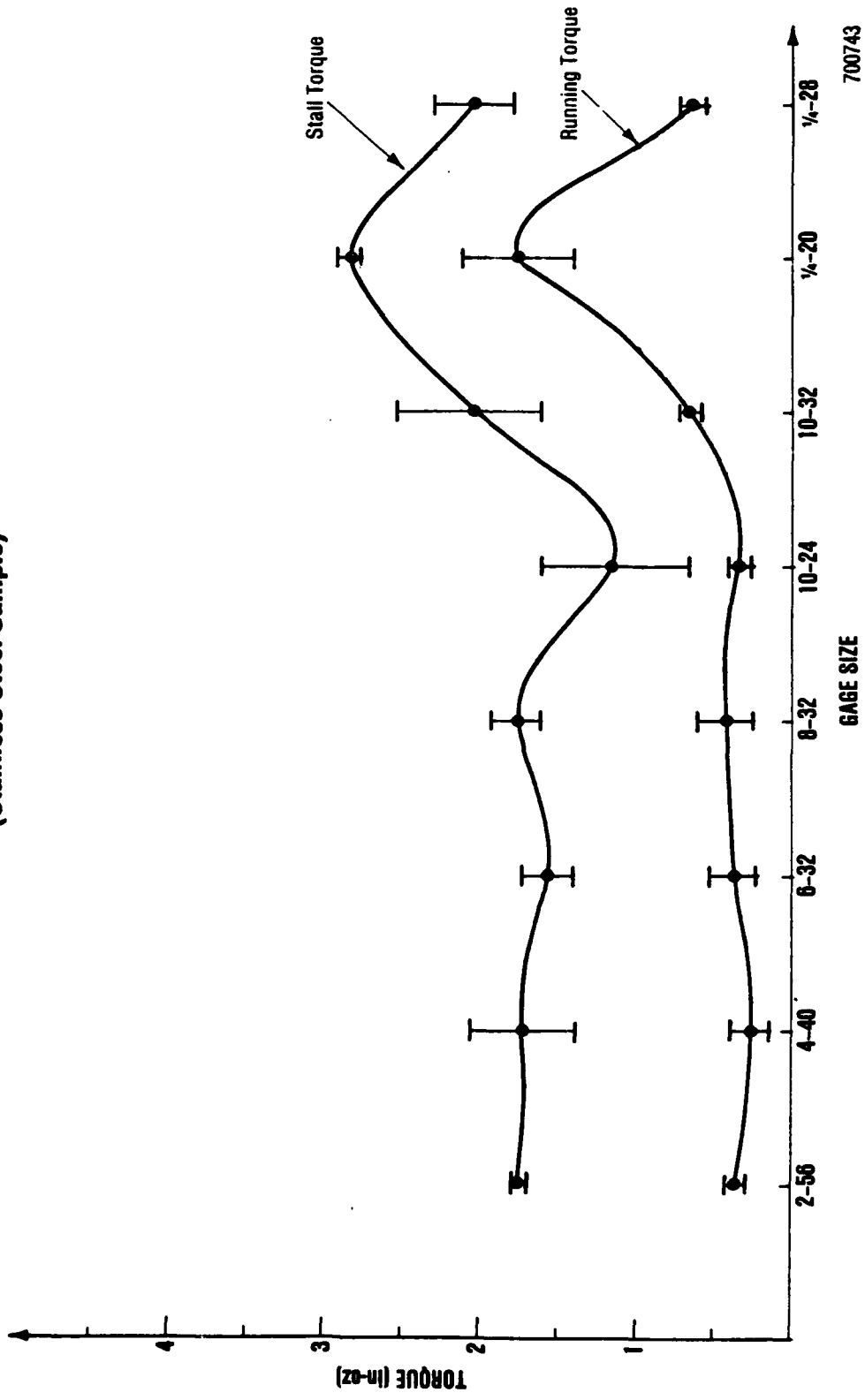

Figure 26

700743

TORQUE VERSUS GAGE SIZE NO.3
(Stainless Steel Sample)

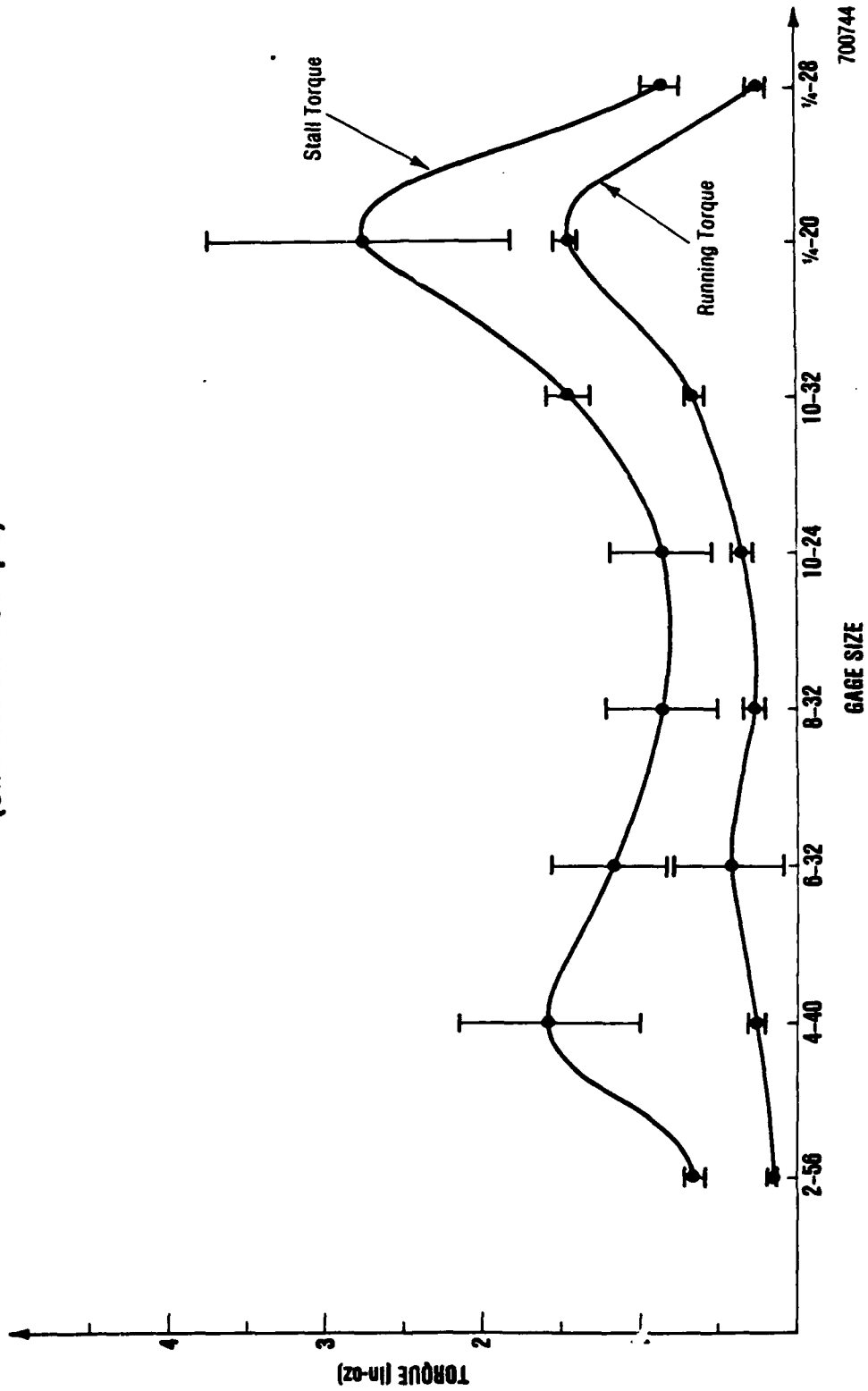
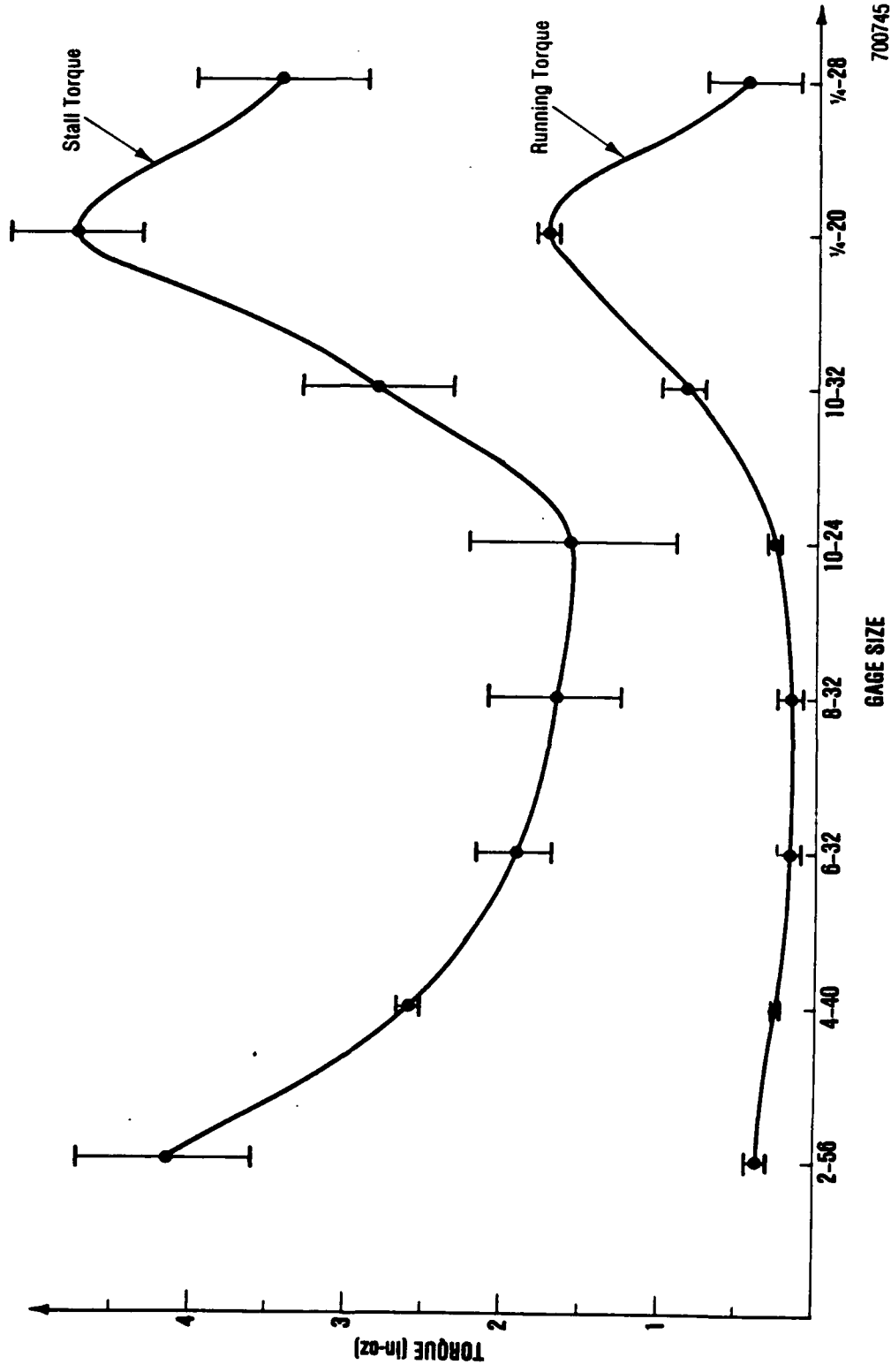

Figure 27

700744

TORQUE VERSUS GAGE SIZE NO.4
(Stainless Steel Sample)



700745

Figure 28

TORQUE VERSUS GAGE SIZE NO.5
(Stainless Steel Sample)

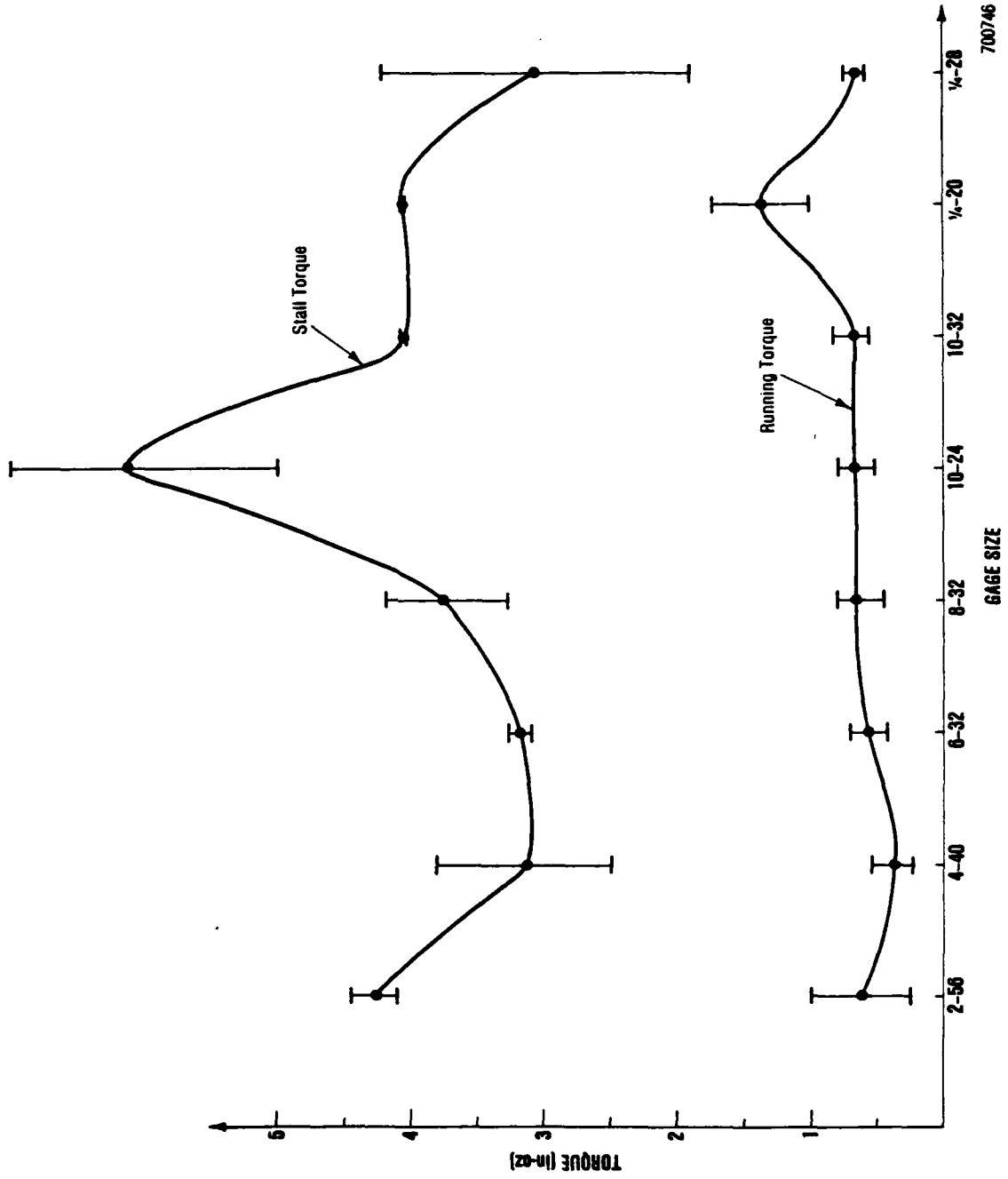
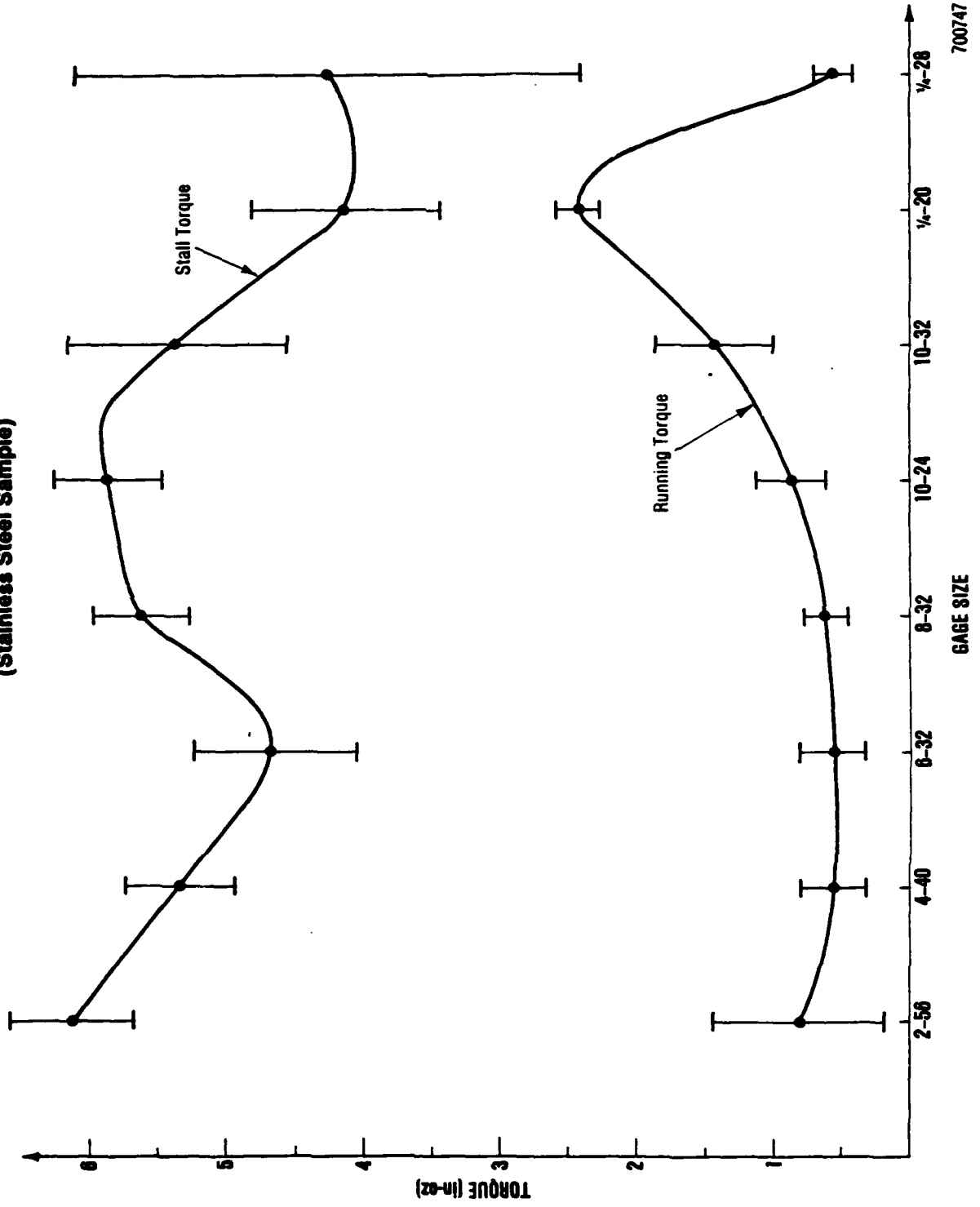

Figure 29

700746

TORQUE VERSUS GAGE SIZE NO.6
(Stainless Steel Sample)



700747

Figure 30

TORQUE VERSUS GAGE SIZE NO.7
(Stainless Steel Sample)

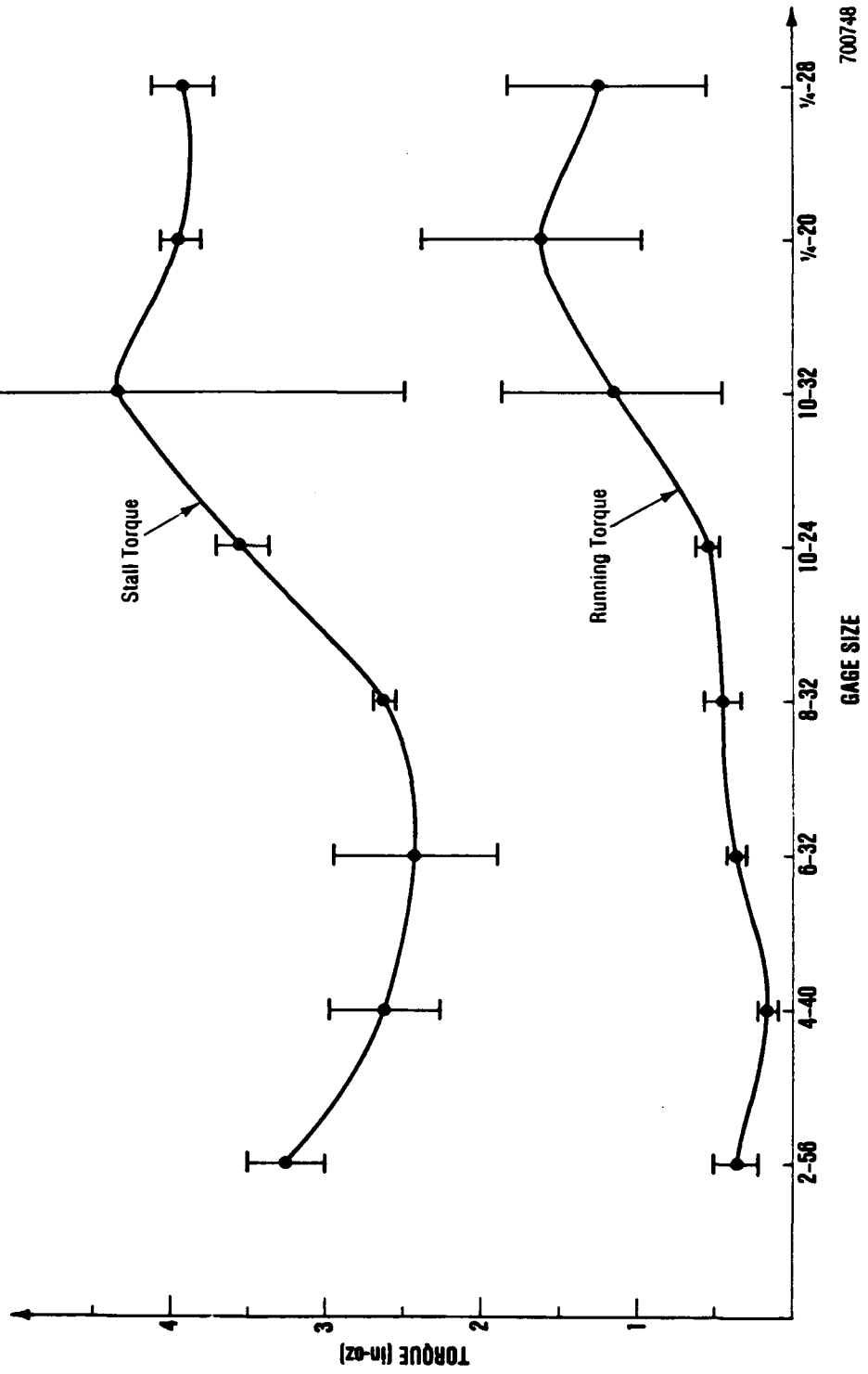

Figure 31

700748

TORQUE VERSUS GAGE SIZE NO.8
 (Stainless Steel Sample)

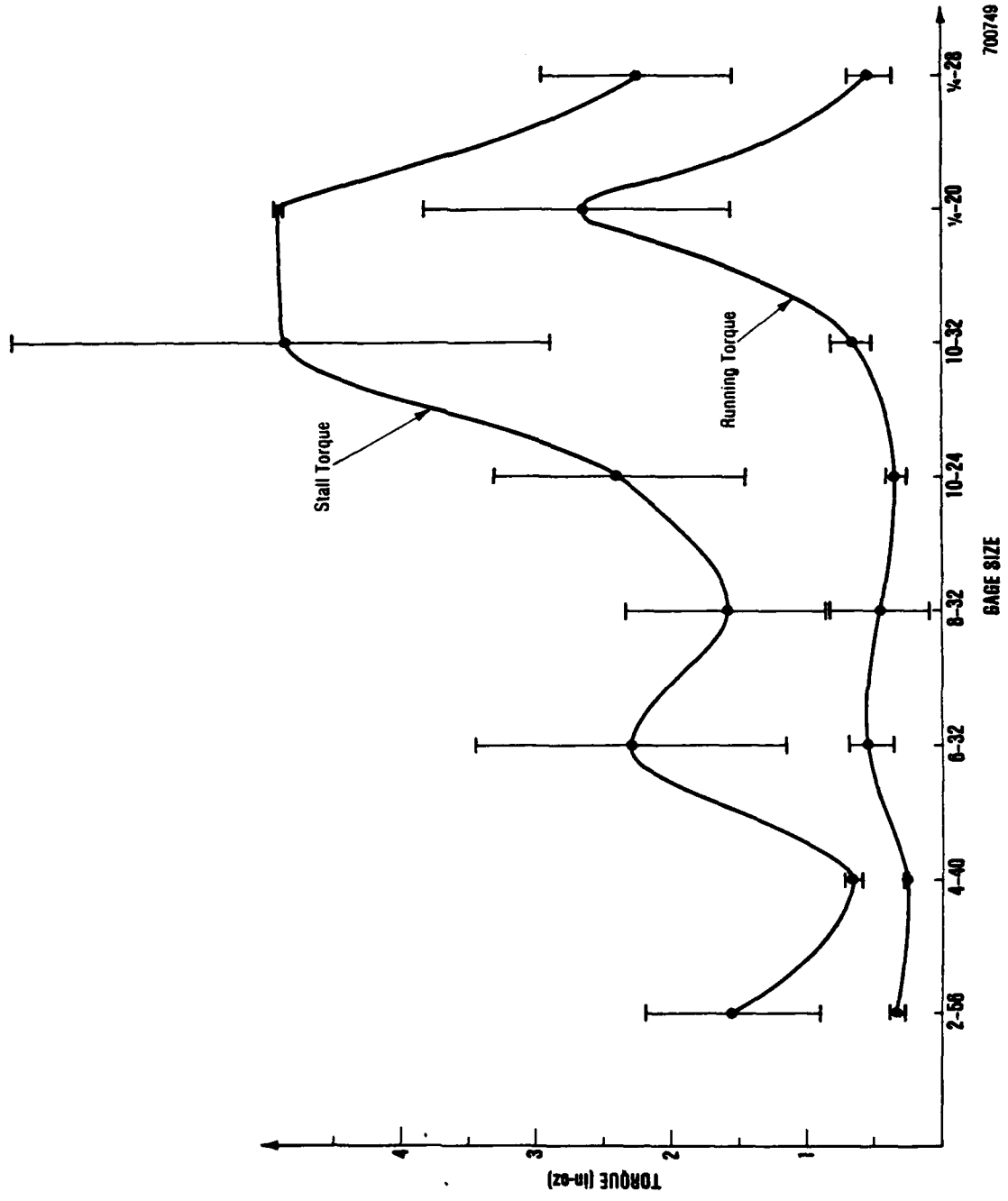

Figure 32

700749

TORQUE VERSUS GAGE SIZE NO.9
(Stainless Steel Sample)

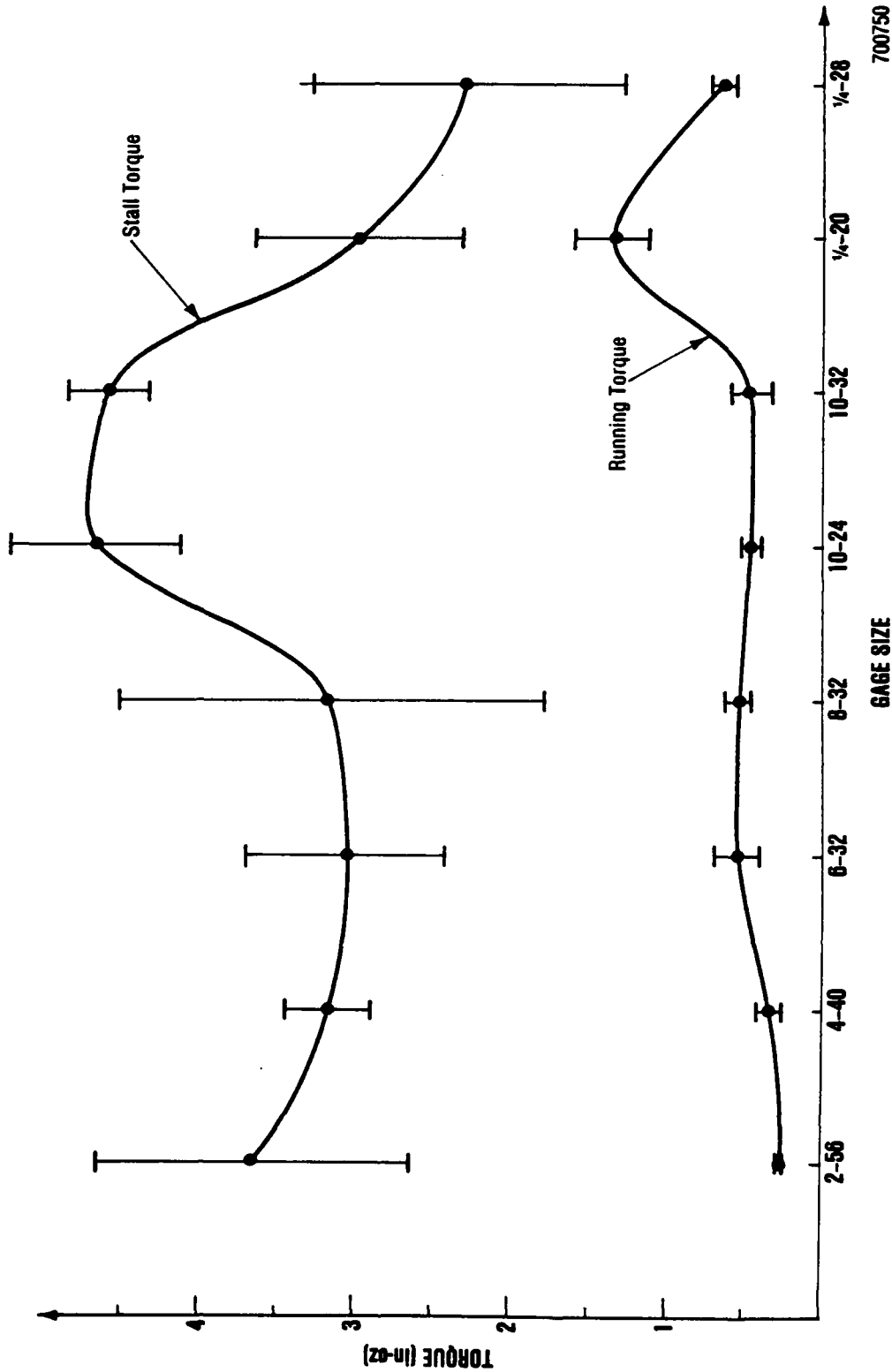

Figure 33

**NORMALIZED DATA
TORQUE VERSUS GAGE SIZE
(Stainless Steel Sample)**

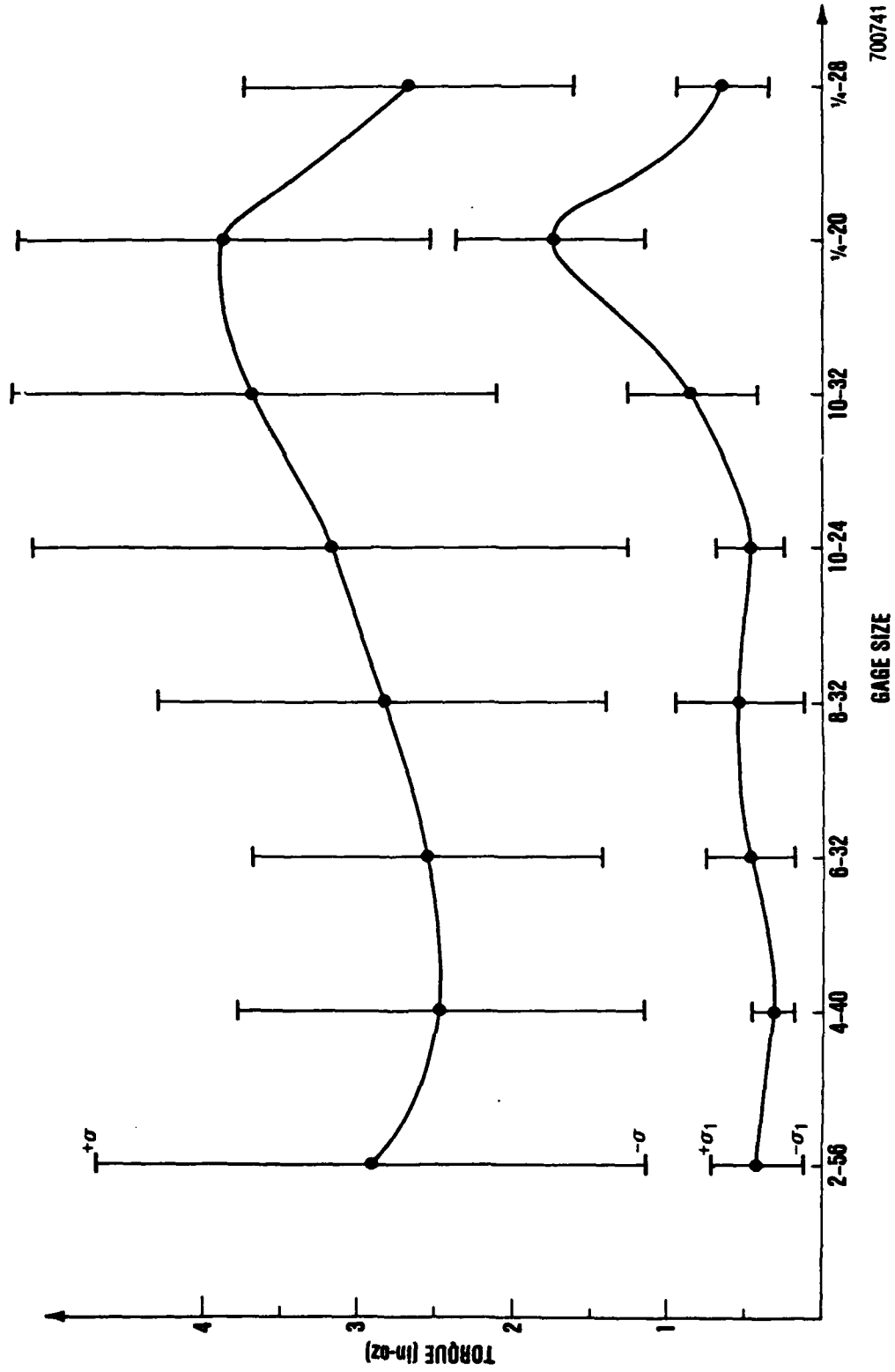
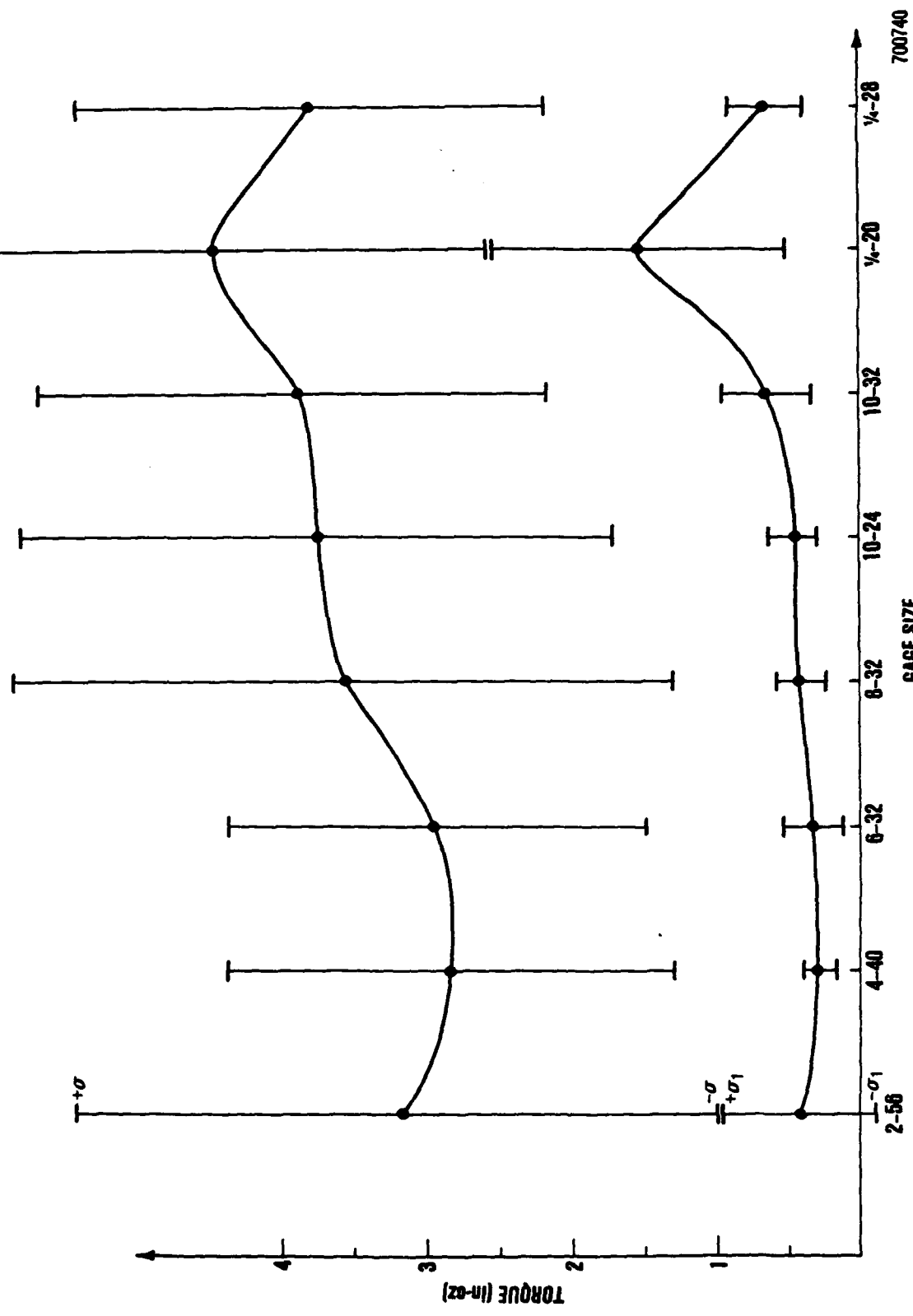

Figure 34

**NORMALIZED DATA
TORQUE VERSUS GAGE SIZE
(Aluminum Sample)**



700740

Figure 35

TORQUE THRESHOLD GUIDELINE

THREAD SIZE	TORQUE THRESHOLD
2	1.5 in-oz
4	2.0 in-oz
6	2.5 in-oz
8	3.0 in-oz
10	3.5 in-oz
1/4	4.0 in-oz

700944

Figure 36

4TH ROTATIONAL AXIS WITH GRIPPER

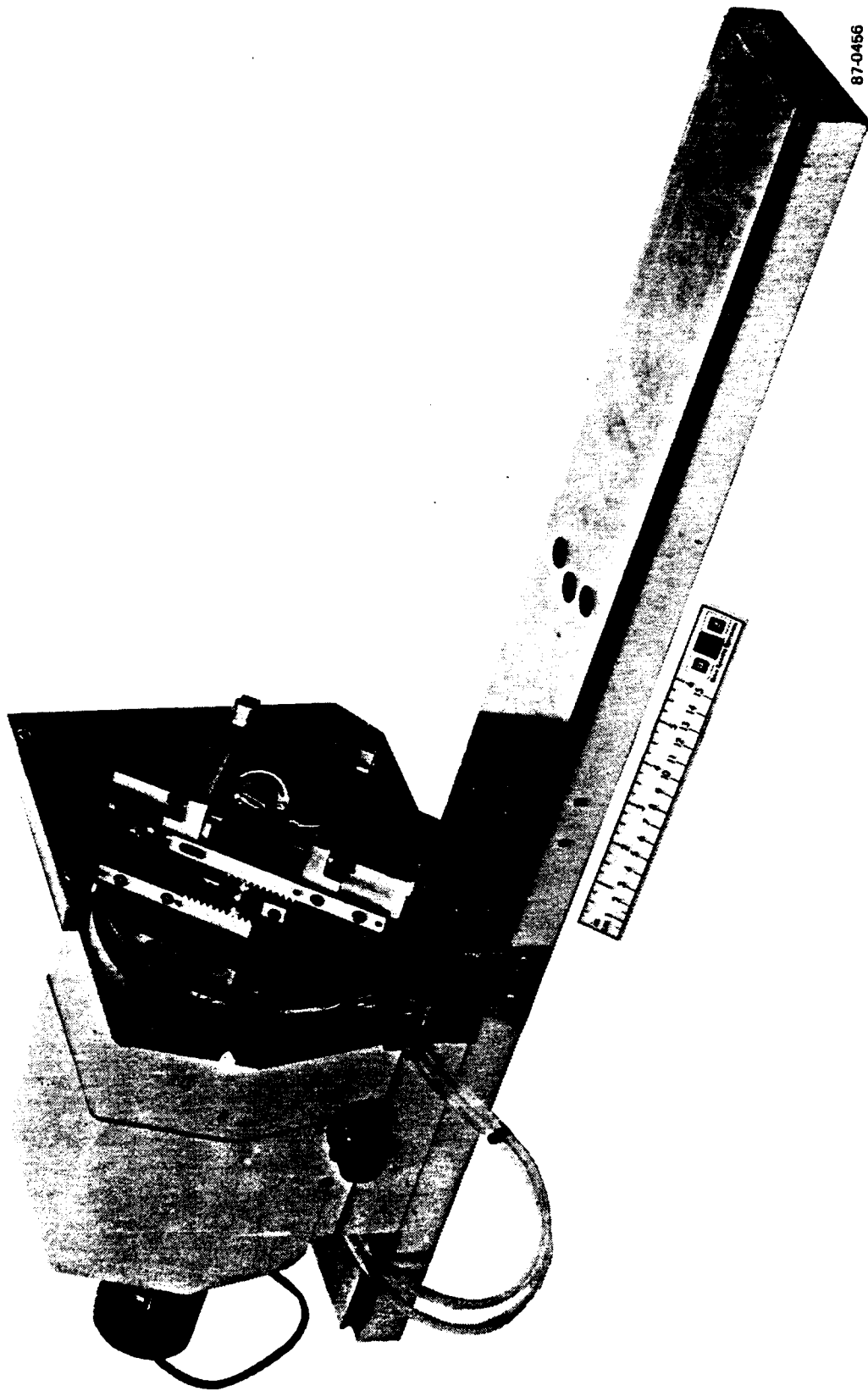

Figure 37

7.2.1 DESIGN

Three parts were chosen from Delco's F-16 Product Line as candidate sample parts for end effector development. (Bracket, 7561002; panel, 7565015; plate, 7566938; See Attached). These components were very representative of large volume hardware requiring thorough inspection at the time of selection. Figure 38 cross references gripper and part pallet designs necessary to accommodate the above sample parts. Figures 39 thru 41 illustrate pallet concepts.

In short, gripper designs were kept simple. A parallel jaw gripper (P/N FLAT-PG-284) for both robot and fourth axis were purchased from Mechanotron, Minneapolis, Mn. They were then modified with rack and pinion gearing (see drawing No. SK005340) to insure each gripper jaw acted synchronously. Gripper fingers were fully adjustable to accommodate various width parts by incorporating a sliding dovetail mount onto the gripper jaw. Range of motion was controlled by installing adjustable stops into the rack and pinion mechanism. Typical clearances between sample parts and gripper fingers, when open, ranged from .10 - .15 inches.

7.2.2 TESTING

During initial testing it was quickly found that all sample parts required accurate fixturing within their pallets in order to predictively place them into the fourth axis gripper system. Due to inaccuracies of robot motion this caused part/pallet binding as they were removed and collisions during pallet loading after inspection was complete.

To eliminate these effects parts were loaded loosely into their pallets. The robot gripper would then acquire a part and transport it to a staging area which consisted of nothing more than a granite surface plate. At the staging plate the robot would orient an edge of the part parallel to the staging plate within .005 inches, release, and then regrip it. Much like squaring off a deck of cards. The robot would then reorient the sample part to another known edge and again release and regrip. After repeating this cycle twice it was found that the robot could place the sample part within the fourth axis gripper with sufficient accuracy without requiring the use of search routines by the vision system. Based on this testing we attained the confidence level necessary to implement a material handling system for the View 1200 inspection process.

**PRODUCT/GRIPPER/PALLET
PART NO. CROSS REFERENCE**

PRODUCT PART NO.	GRIPPER PART NO.	PALLET PART NO.
BRACKET 7561002	SK005390	SK005397
PANEL 7565015		SK005390
PLATE DG 100034		SK005396

700945

Figure 38

SAMPLE PART 1

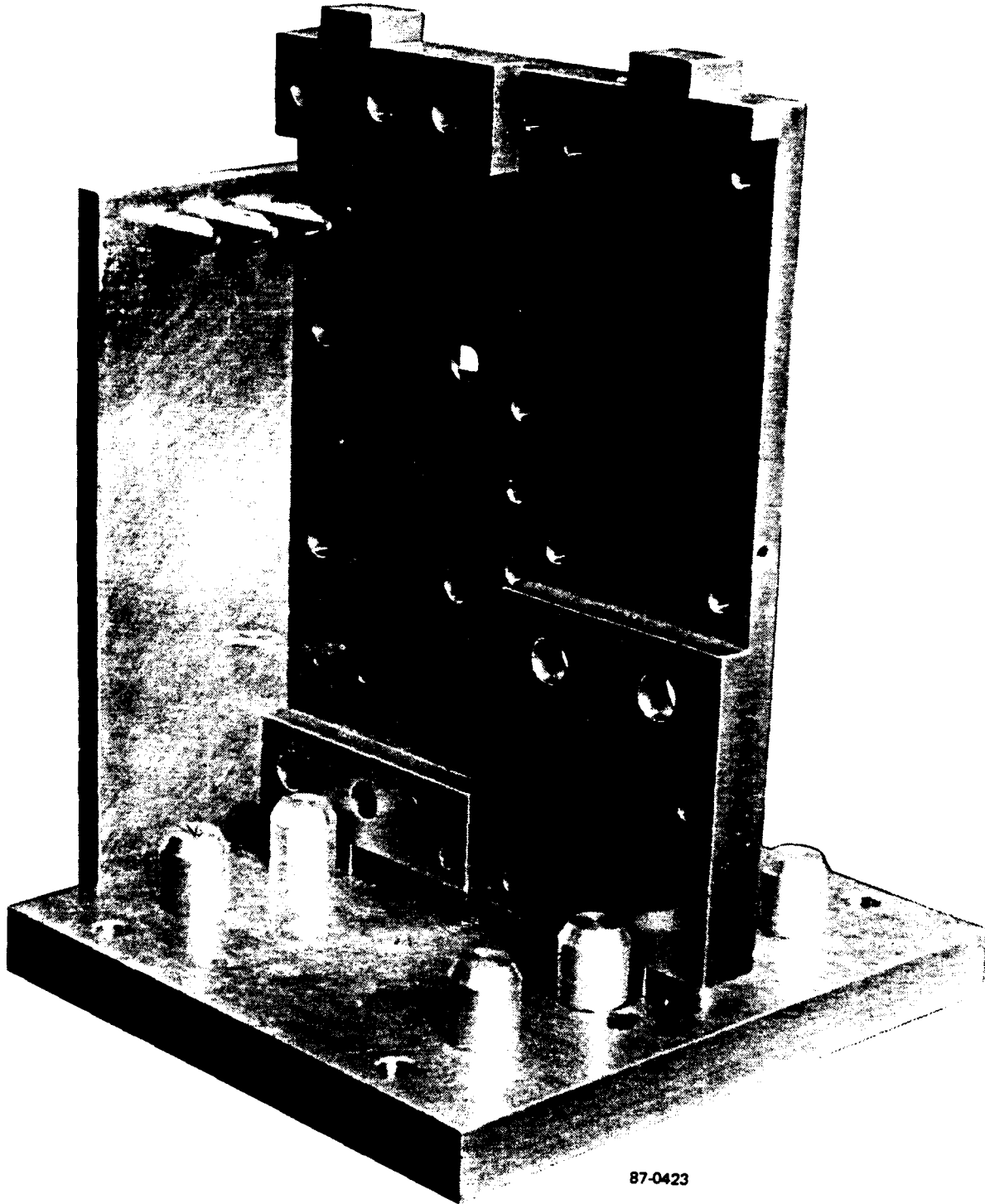

87-0423

Figure 39

SAMPLE PART 2

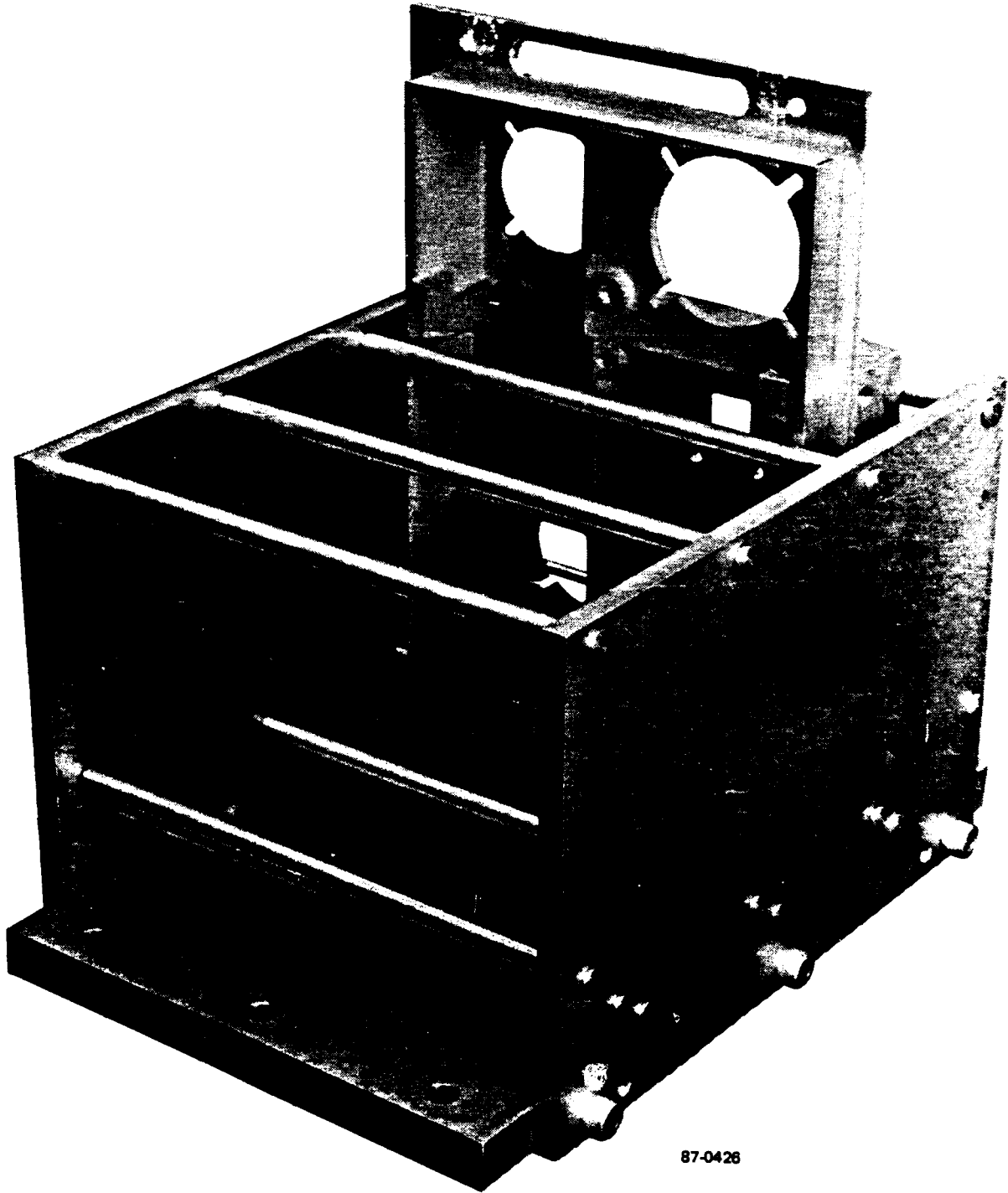

87-0426

Figure 40

SAMPLE PART 3

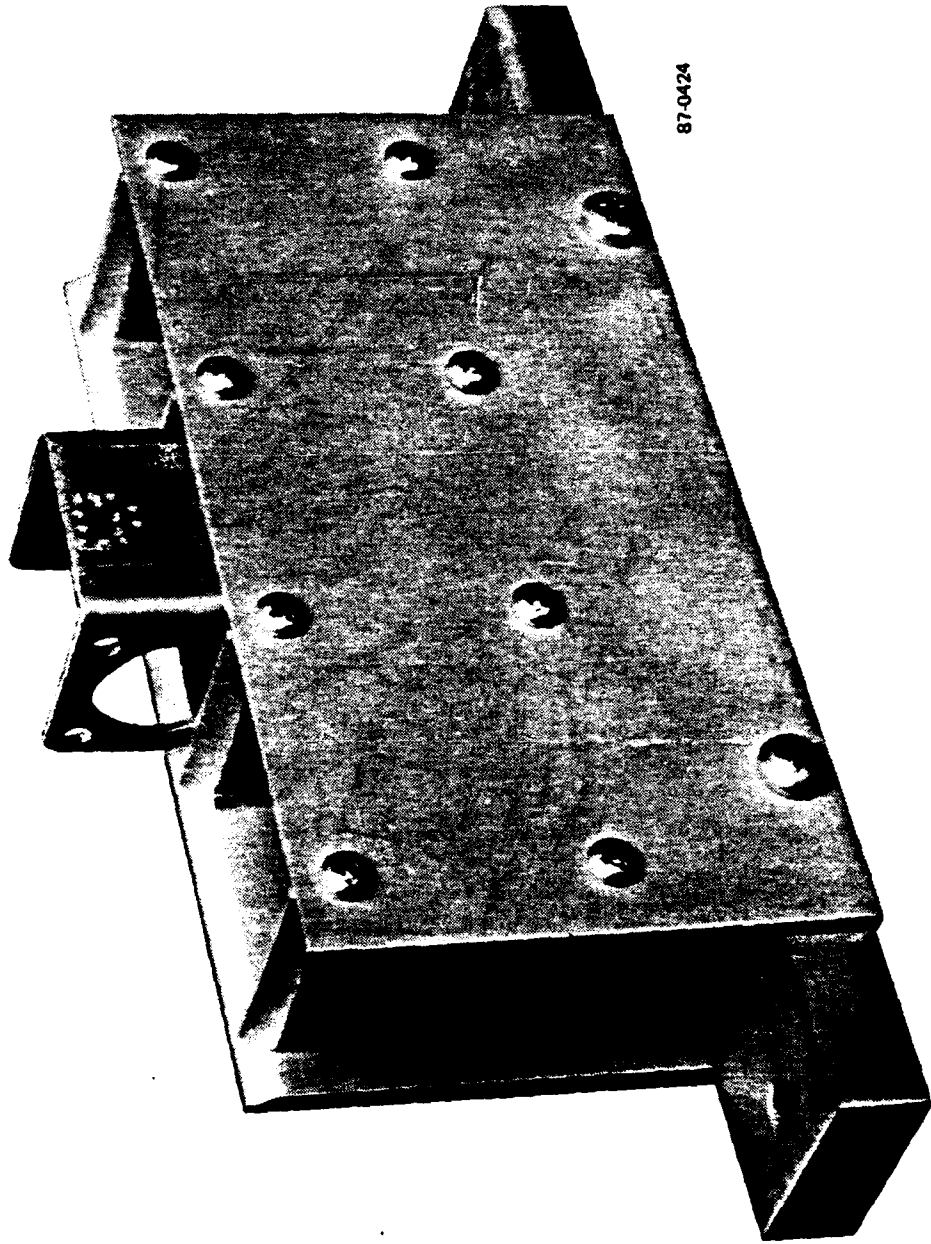

Figure 41

8.0 PROOF-OF-CONCEPT DESIGN

8.1 STATEMENT OF WORK DEFINITION

Based on the successful enabling technology development and testing it was determined that the automated mechanical inspection cell concept employing both dimensional and robotic thread inspection was technically feasible. The next step was to identify the specifications and standards required to construct a complete cell. Though the intent at this time was to develop only those subsystems that would represent a proof-of-concept design, it was felt that an overview of a total cell concept was necessary. Form the proof-of-concept cell additional subsystems and capabilities need only be added minimizing any potential redesign. Attached is a Statement of Work (E41-001) identifying the final cell design.

8.2 SYSTEM SUPERVISORY COMPUTER (SSC) CONTROL DESIGN

The primary function of the control program is to cause the execution of a series of View 1200 programs and Karel programs to take place in a specific sequence. The result of executing these programs is the inspection of the selected part (Attached is an example of A typical inspection report) according to the steps contained in these 'station programs'.

The names of programs to be executed at the stations are stored, in sequence of execution, in a file on disk. Through a series of menus (attached) presented on the system console, the operator makes selections which ultimately result in the use of the appropriate list of station programs. These programs are downloaded to and executed at the appropriate station, and results of the inspection process are uploaded to the SSC and stored on disk. When the end of a station program is sensed, the next program is processed in a similar fashion. This process continues until the list of station programs is exhausted. At this point, the specified inspection is complete and the operator is once again presented with the initial menu which began the process just described.

The station programs to be executed can reside on either mountable flexible disk, or permanently mounted Winchester disk. The operator specifies their location as part of the menu oriented dialog prior to part inspection.

The operator is kept abreast of inspection progress through a series of informational and explanatory messages. In certain cases, when an operator selection error has been detected by the control program, such messages are followed by repetition of the menu selection or prompt requiring correction.

8.2.1 EXCHANGING MESSAGES WITH THE VIEW 1200

Station programs and inspection results are transferred between the View 1200 and SSC through control program implementation of a

message exchange protocol compatible with the protocol supplied as part of the View 1200. Capabilities include transfer of station programs in both directions, receipt of inspection results at the SSC and transmission of control commands to the View 1200.

8.2.2 EXCHANGING MESSAGES WITH THE KAREL CONTROLLER

Station programs and inspection results are transferred between the Karel and the SSC through the use of Digital Data Communications Message Protocol (DDCMP) and Manufacturing Message Format Specification (MMFS). DDCMP is widely used, and was developed by Digital Equipment Corporation. MMFS is part of the Manufacturing Automation Protocol (MAP) originated by General Motors. The Karel provides a subset of the full MMFS; it and the portion implemented for use on the SSC provide sufficient capability for transfer of station programs, transmission of inspection results and SSC control of the Karel.

8.3 THREAD INSPECTION EOAT DESIGN

The thread Inspection End-of-Arm-Tooling is comprised of: 1) a Motorized Drive System with positional encoding, 2) a gage holding mechanism with built in compliance, 3) Control Electronics, and 4) Control Software. The system was designed to operate on command from a GMF Karel Controller, however, is fully adaptable to any other robotic controller provided it has discrete and RS232 with read/write I/O capability.

8.3.1 MECHANICAL HARDWARE

The mechanical end-of-arm-tooling consists of two basic units (see Figure 42). The upper drive section contains a 20 inch-oz DC Servomotor, 1000 count encoder, and 40 conductor slip ring. The encoder is used for speed control and positional feedback to a motor controller while the slip ring supplies power and sensor access to the rotating tool section. The lower tool section consists of a telescoping gage tip, bellows joint for lateral compliance, 12 VDC Solenoid drive to extend the tool tip, and a home sensor.

When the gage is positioned over the tapped hole the solenoid drive extends the gage off it's seat and mildly preloads it against the tapped hole opening. This action also allows the gage to improve its orientation laterally over the tapped hole due to the bellows linkage above. As the gage is drawn into the hole, solenoid power is no longer required and it is de-energized. When the programmed threshold torque, specific to the thread size, is attained rotational motion is stopped. A counter within the motor controller is zeroed and counter-rotation, to extract the gage, is started. As the gage is extracted the robot moves in a positive direction .25 inches at the same exit feed-rate as the gage. This allows the gage to snap out of the tapped hole into its home position. When the sensor output is detected motor motion is stopped and a total exit revolution count can be determined. Knowing the thread pitch, the depth of the tapped hole can be calculated.

By trial and error it was determined that the robot could position the gage over the hole within $\pm .015$ inches without any noticeable effects on torque thresholding. This allows usage of this EOAT on just about any robot without effecting its performance and allowed us to delete the requirement of closing a force loop with the robot in X and Y directions to guarantee gage-to-threaded hole alignment.

During the initial testing phase we assumed that threshold torque measurements would have to be monitored by the force/moment sensor. However, it soon became apparent that due to mechanical noise contributed by the robot that the sensor could not resolve the required torques. Attempts were made to mount the sensor in the rotating frame as well as the stationary frame to no avail. It was then determined that by scaling motor current, threshold torques could be measured at their desired resolution. The system by which this was achieved will be discussed in greater detail in the following section.

8.3.2 CONTROL ELECTRONICS/SOFTWARE (KAREL)

The controlling elements of the thread inspection EOAT include a motor controller, digital torque detection electronics, and the Karel Controller.

Operationally the system has two modes: Calibration and Running. During the Running Mode Programming specific to hardware requiring inspection positions the EOAT over the first threaded hole to be gaged. At this time a standardized subroutine (Attached) is recalled from memory and commands are downloaded via RS232 and discrete I/O from the Karel Controller to the Motor Controller and Torque Detection Electronics, respectively.

The Motor Controller requires information defining direction of rotation and maximum number of entry revolutions. The Torque Detection Electronics receives an 8-bit discrete signal defining the threshold at which gage rotation stops. After setup information is received a 'start' command is sent to motor controller. When the Torque Threshold, specific to thread size, is attained a discrete signal is returned to the Karel whereupon it transmits a "stop motion" command to the Motor Controller. At this time, the rotational counter register in the Motor Controller is also set to zero. This allows exit revolutions to be counted during extraction. When the gage exits the tapped hole the home sensor within the EOAT acts similarly to the thresholding circuit. It notifies the Karel Controller that a "stop motion" command needs to be transmitted to the Motor Controller.

As indicated earlier, torque is determined by scaling motor current. To account for motor current required to drive the EOAT (without thread engagement) a calibration mode was added. During system initialization at power up, software (attached) at the Karel commands the motor to rotate ten revolutions. During this time current is monitored, averaged, digitized and stored into memory located on the torque detection electronics board. During the remainder of the "work shift" this value is added to the desired torque threshold downloaded from the karel thereby compensating the system for inherent frictional effects.

Also, during calibration user specific parameters required by the motor controller are set. For our application these included

motor speed, acceleration, pole and zero locations (control feedback parameters) and operational mode (velocity, position or torque). This application required the motor to work in a velocity mode. Reference figures 43 A,B,C for a block diagram representation of the above described process.

8.4 LABORATORY LAYOUT

The laboratory layout used during the Proof-of-Concept phase is shown in Figure 44. Robot location was chosen to facilitate material handling concept tests with the View 1200.

EOAT CROSS SECTION VIEW

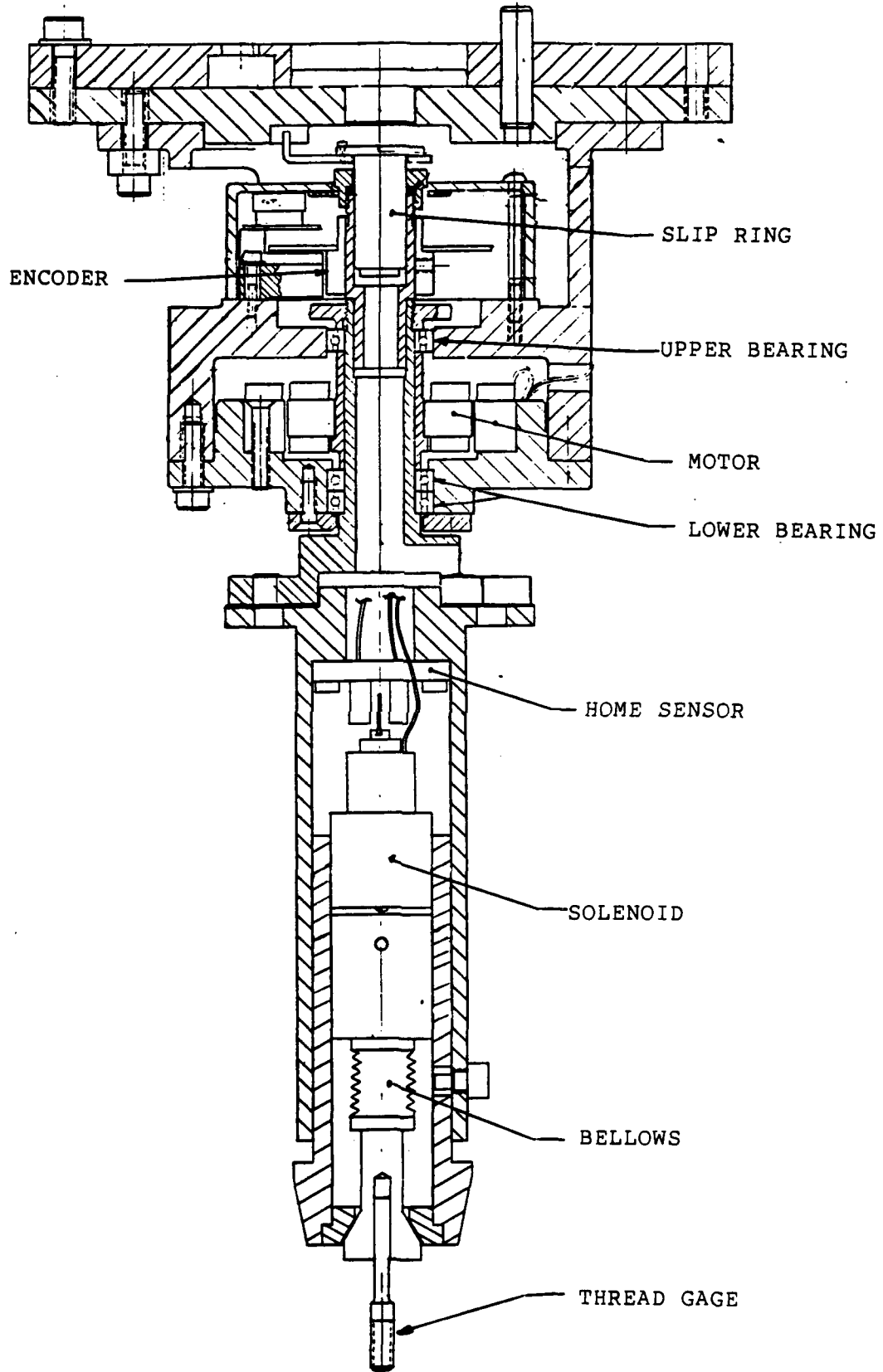
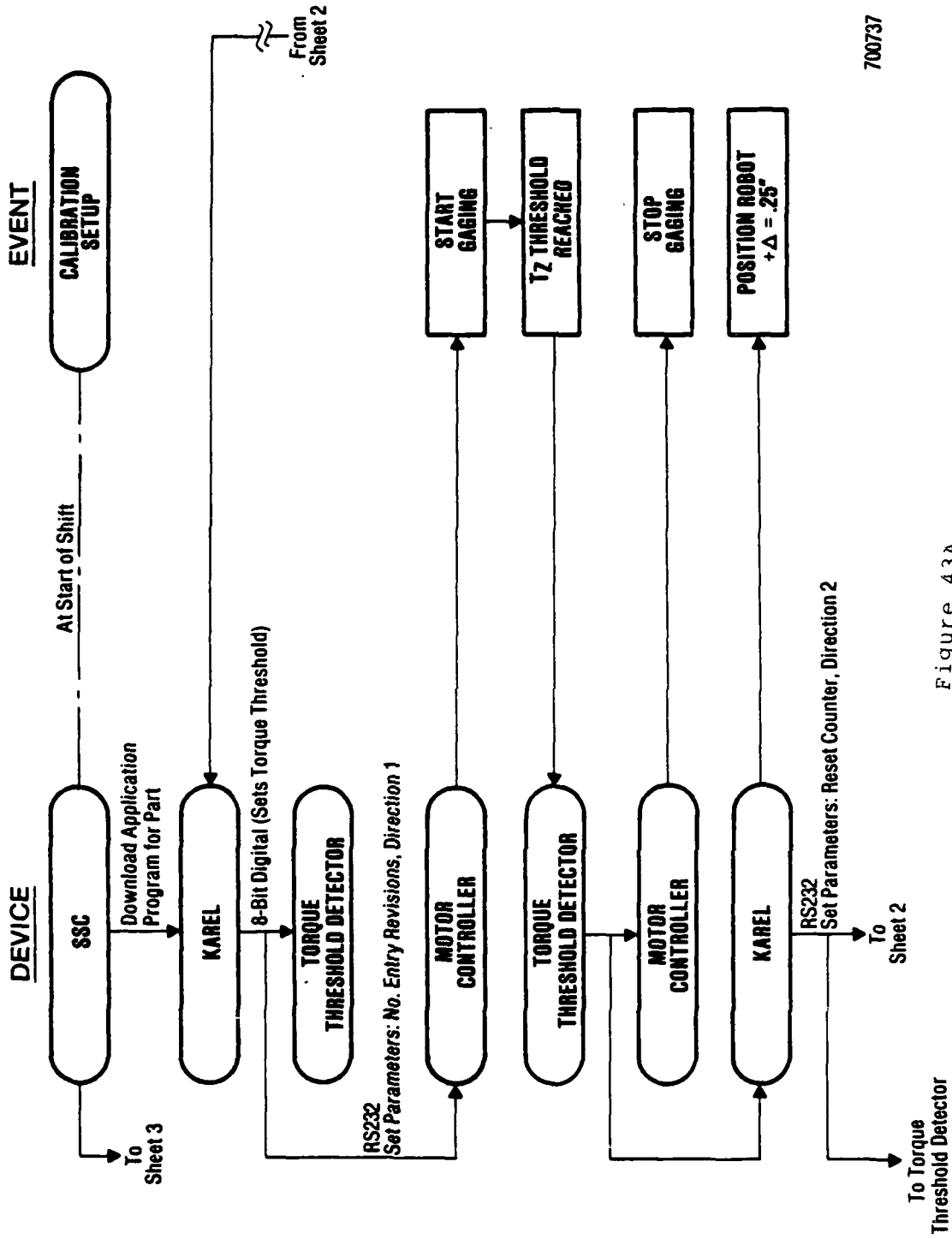

Figure 42

THREAD INSPECTION SEQUENCE



700737

Figure 43A

THREAD INSPECTION SEQUENCE (Con't)

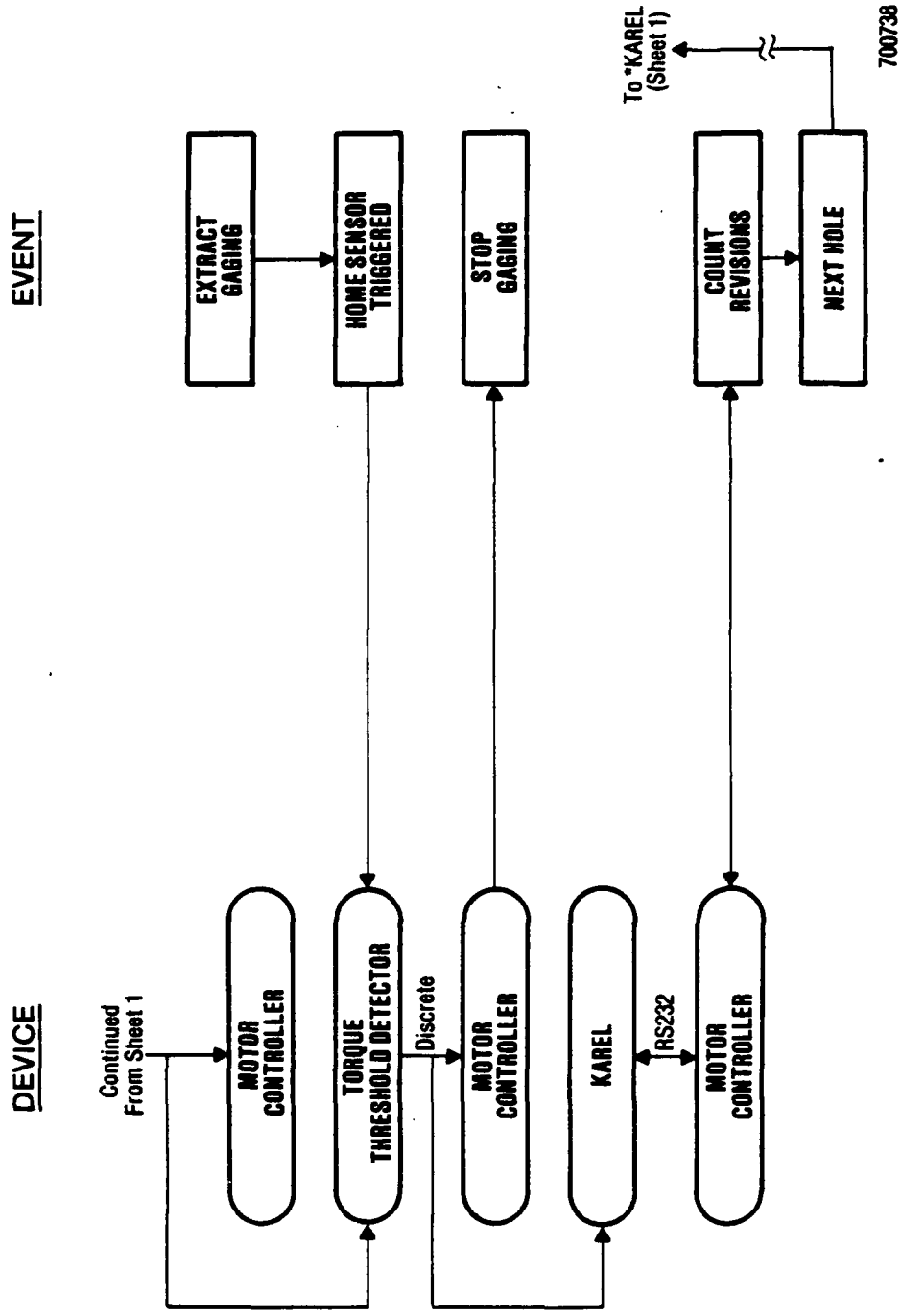

Figure 43B

CALIBRATION SEQUENCE (Cont'd)

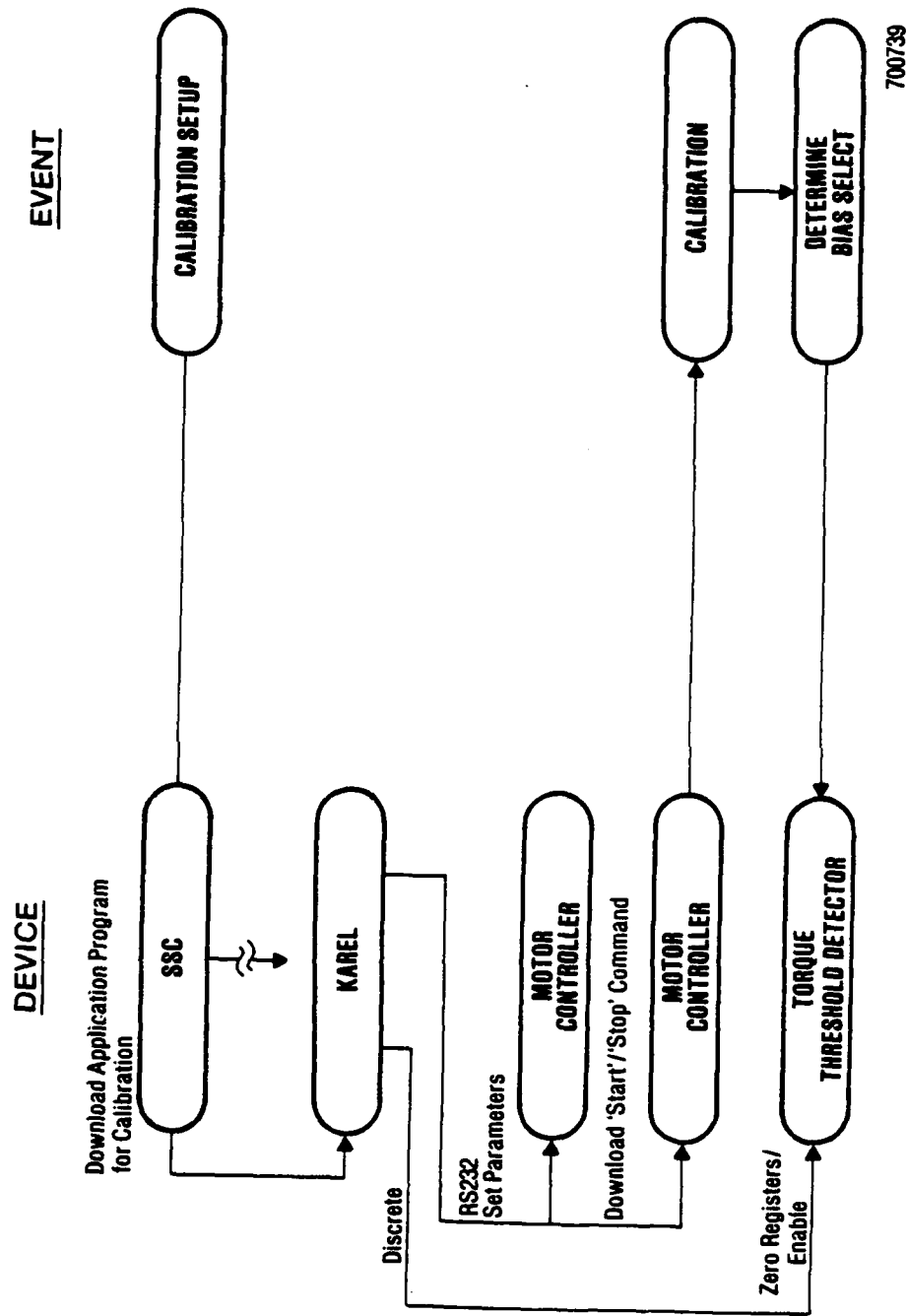
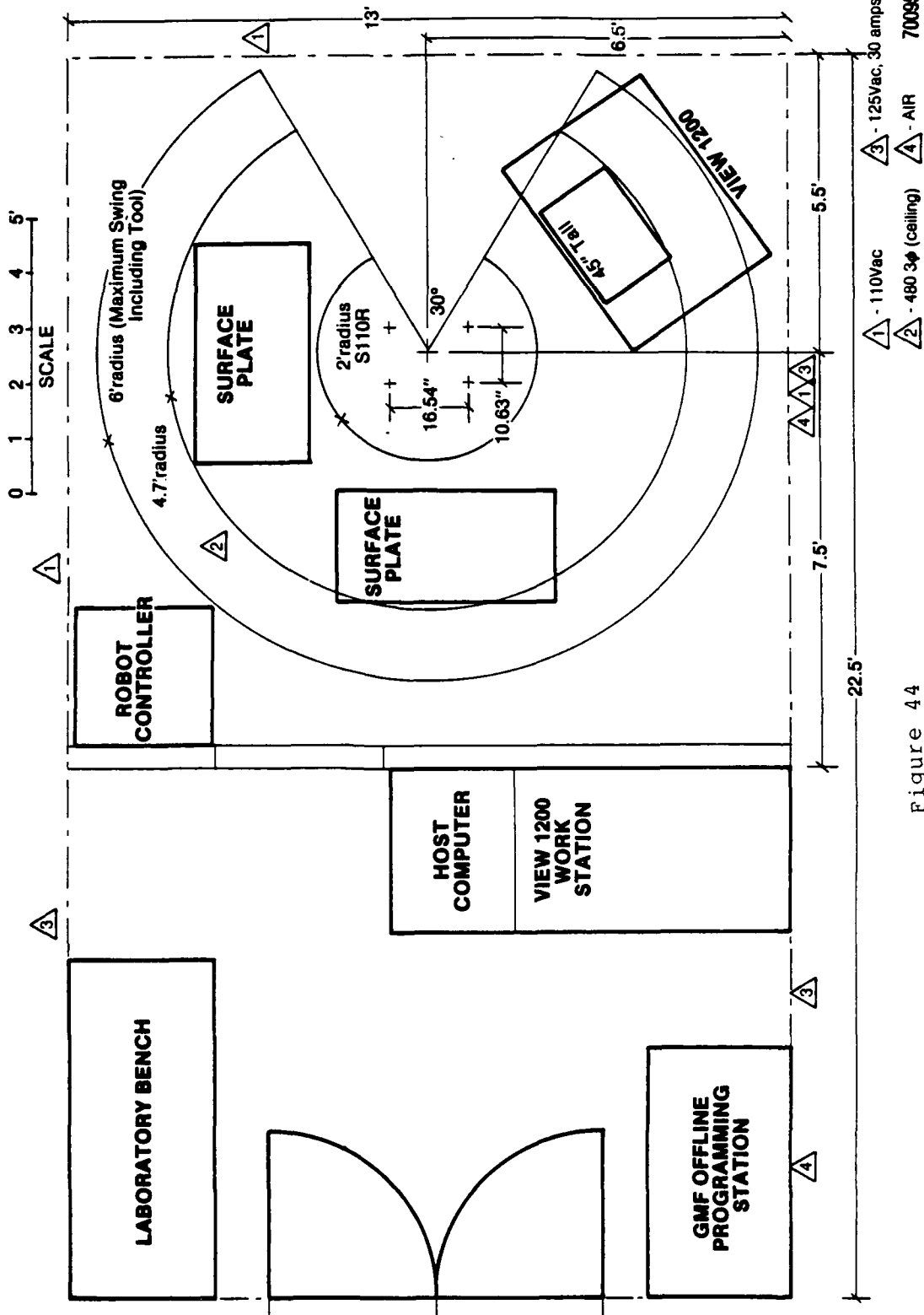

Figure 43C

LABORATORY LAYOUT



AREAS FOR FUTURE CONCERN/DEVELOPMENT

To complete the thread inspection system, gaging quick-change concepts in addition to drive system redesigns need to be addressed. Presently, Go and No Go Gaging is mechanically fastened to the end-of-arm-tooling. Conversion to a quick change tooling concept requires an electro-magnetic quick design to replace the existing tool holder. Regarding drive system redesign, the existing assembly utilized design configurations originally intended to meet a broad range of test requirements or performance standards. Selection of the 40 conductor slip ring was based on unknown electronics that potentially may have been placed in the rotating frame. A redesigned assembly would need no more than 7 conductors (3 for home sensor, 2 for solenoid and 2 for proposed electromagnetics). The designed bearing configuration utilizes a duplexed bearing set in the lower housing section and a single bearing in the upper. Again, due to unknown payloads at the time of design an overly rigid structure was conceived. Redesign would eliminate one bearing from the lower section and reconfigure the bearing style to a spaced duplex set.

The benefits of the drive system redesign would decrease the free running torque. This torque is approximately .7 - .9 in-oz. and is presently compensated for during the calibration mode. Depending of the final design and subsequent testing it may be possible to eliminate the calibration mode all together.

FINAL DESIGN

At approximately halfway through the proof-of-concept development effort it became apparent that thread inspection would not be utilized in a production capacity as initially expected. Programs involving large volumes of "bare" tapped holes have been completed and anticipated programs did not materialize. The bulk of Delco's future programs involving mechanical assemblies have been outsourced and rely heavily on source inspection. Also, those assemblies that will be fabricated in house utilize locking inserts for which this inspection cell was not designed. For these reasons the study effort regarding thread inspection was completed, however final designs to implement this system on a production basis were not pursued. The original intended user of the inspection cell was the Delco Milwaukee Manufacturing Group. However, due to product and inspection outsourcing the installation location has changed to Delco Systems in Goleta.

The final system configuration also reverted to the stand alone View 1200 without material handling and thread inspection. The View 1200 Fourth Rotational Axis was modified to include a tooling plate onto which adapter plates product-specific could be mounted (see Figure 45). This minimized dedicated tooling while allowing multiple part orientations.

Due to inherent limitations of the View 1200 it will support inspection activities normally assigned to our resident coordinate measuring machine, not replace it. These limitations are basically due to programming vs. Quantity tradeoffs and physical limitations of the equipment (ie; it's ability to place the lens at the required location to acquire an image without interfering with a part feature such as a web or wall). Because this equipment in effect becomes support to the existing receiving inspection function no change to the IDEF Model is realized. The as-is IDEF Model is shown in Figure 46.

4TH ROTATIONAL AXIS WITH TOOLING PLATE

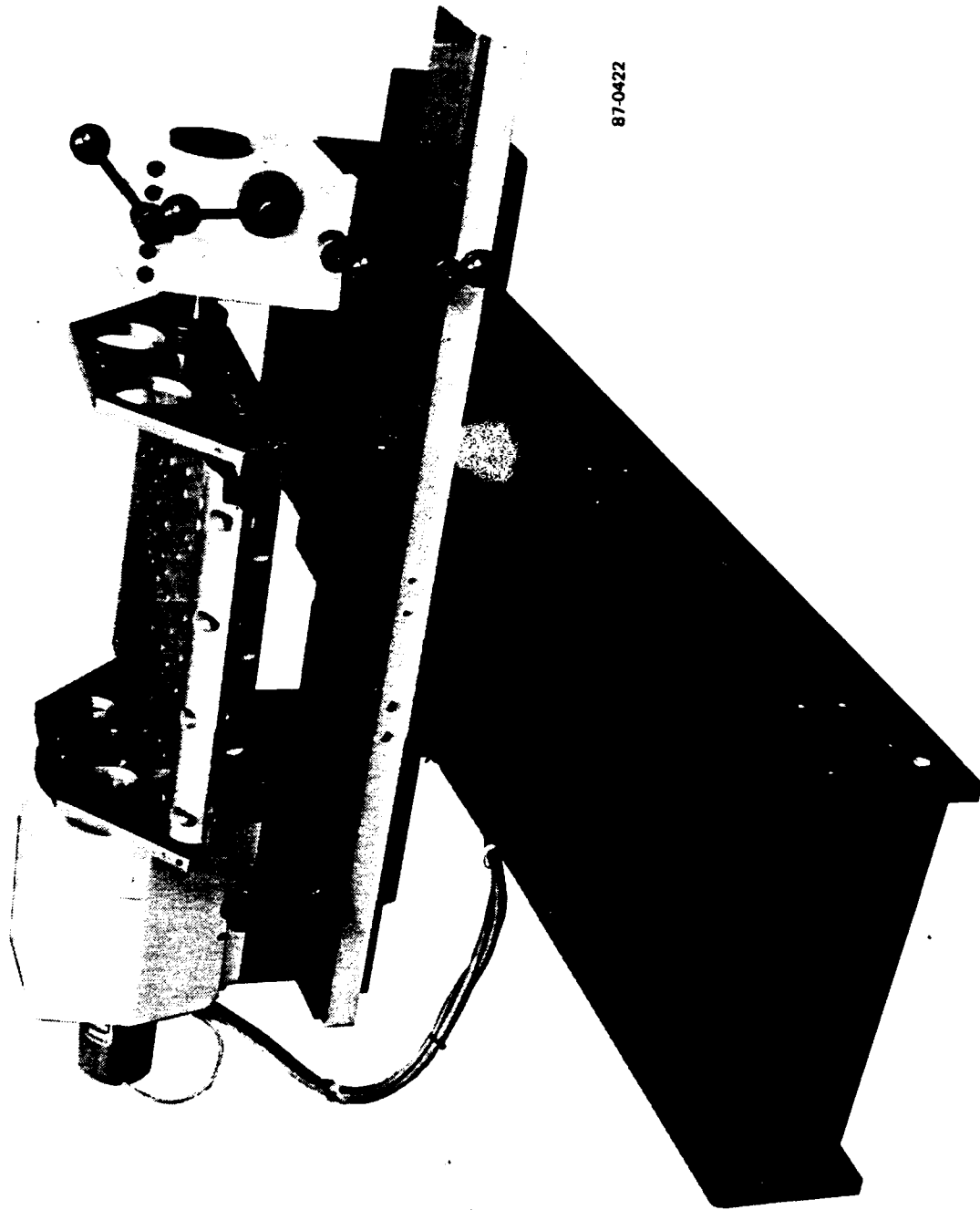

87-0422

Figure 45

PERFORM TEST, INSPECT, AND EVALUATE (AS-IS)

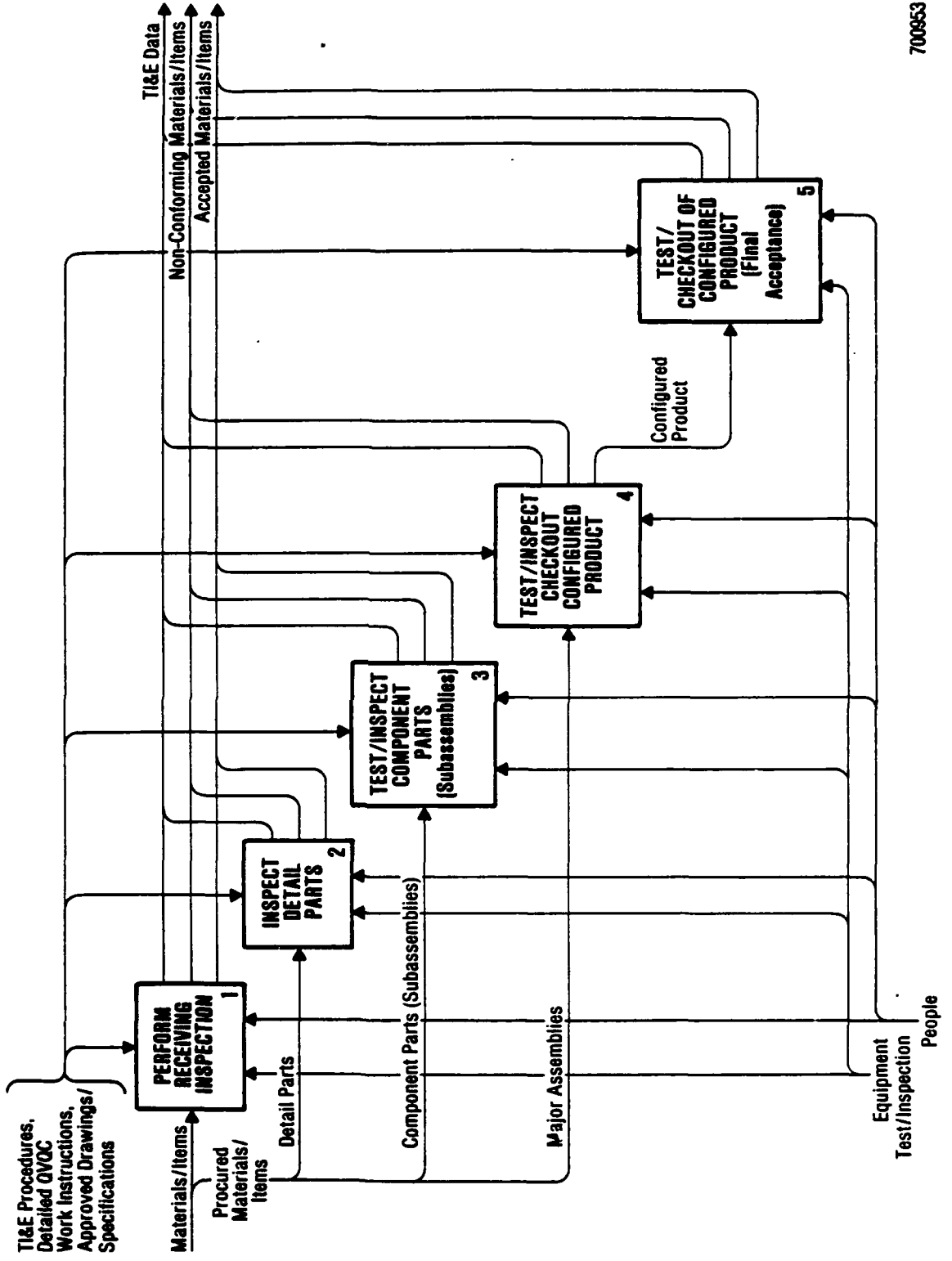

700953

Figure 45A

PERFORM RECEIVING INSPECTION (As-Is)

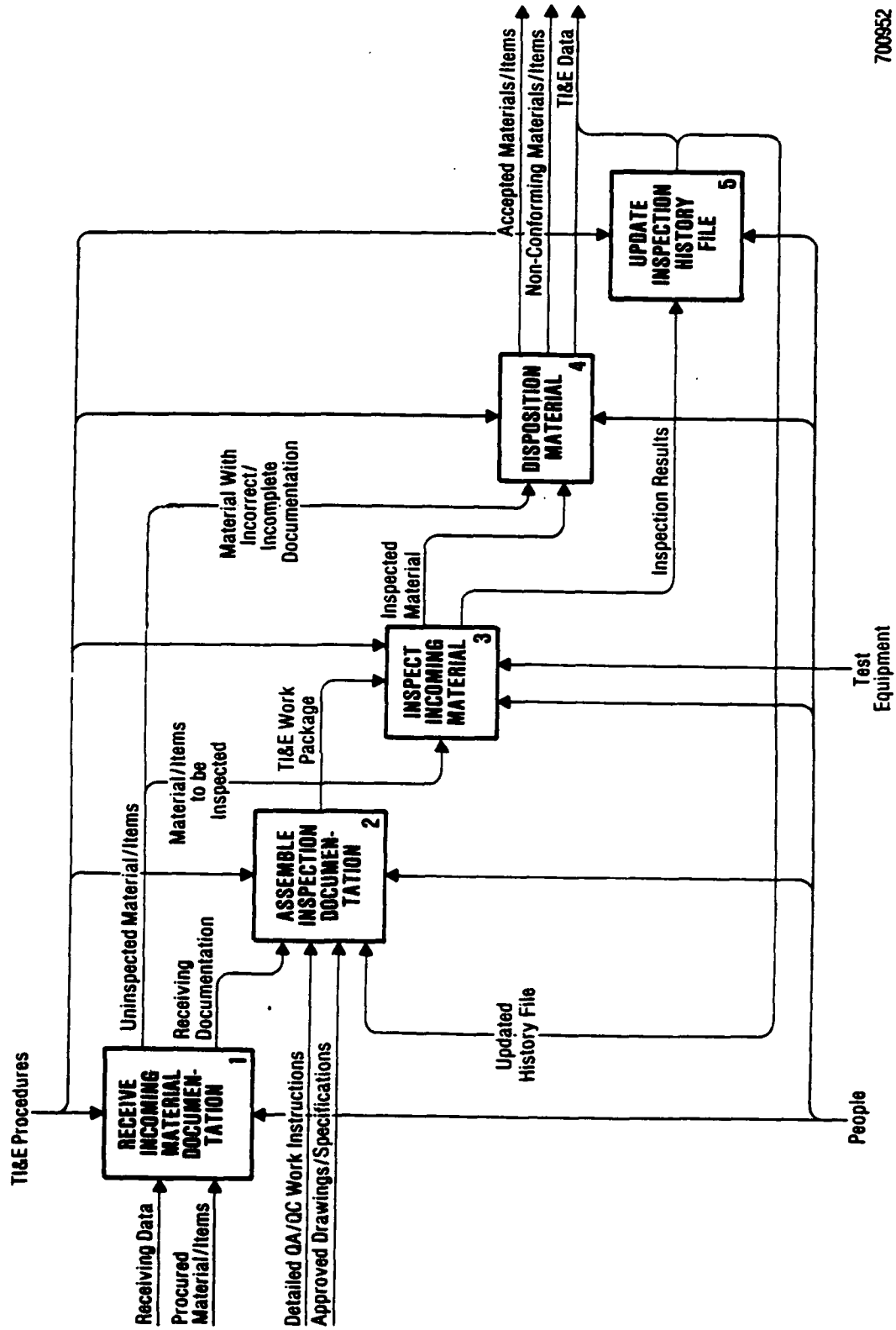
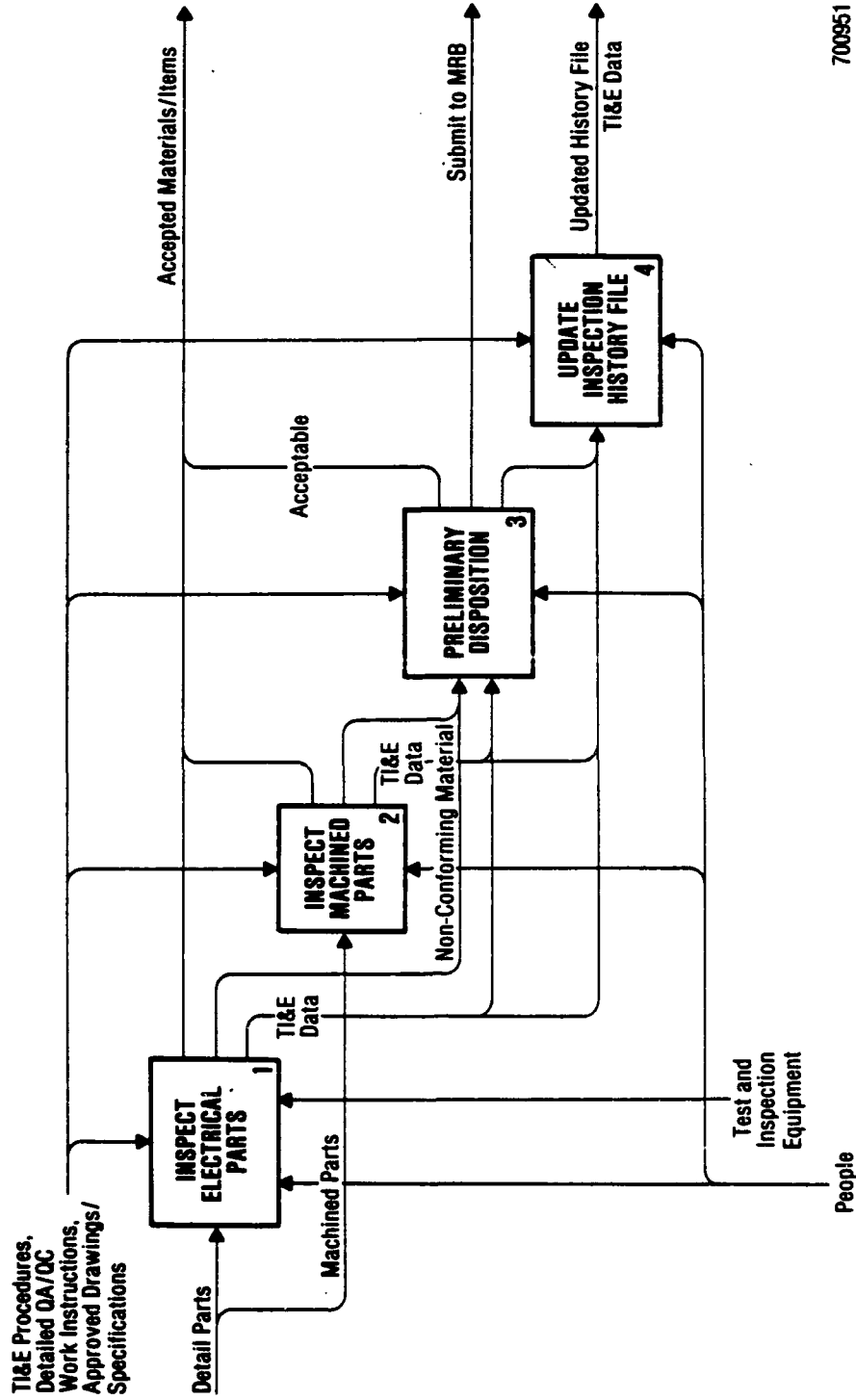

Figure 46B

INSPECT DETAIL PARTS (As-Is)



700951

Figure 46C

INSPECT MACHINED PARTS (As-Is)

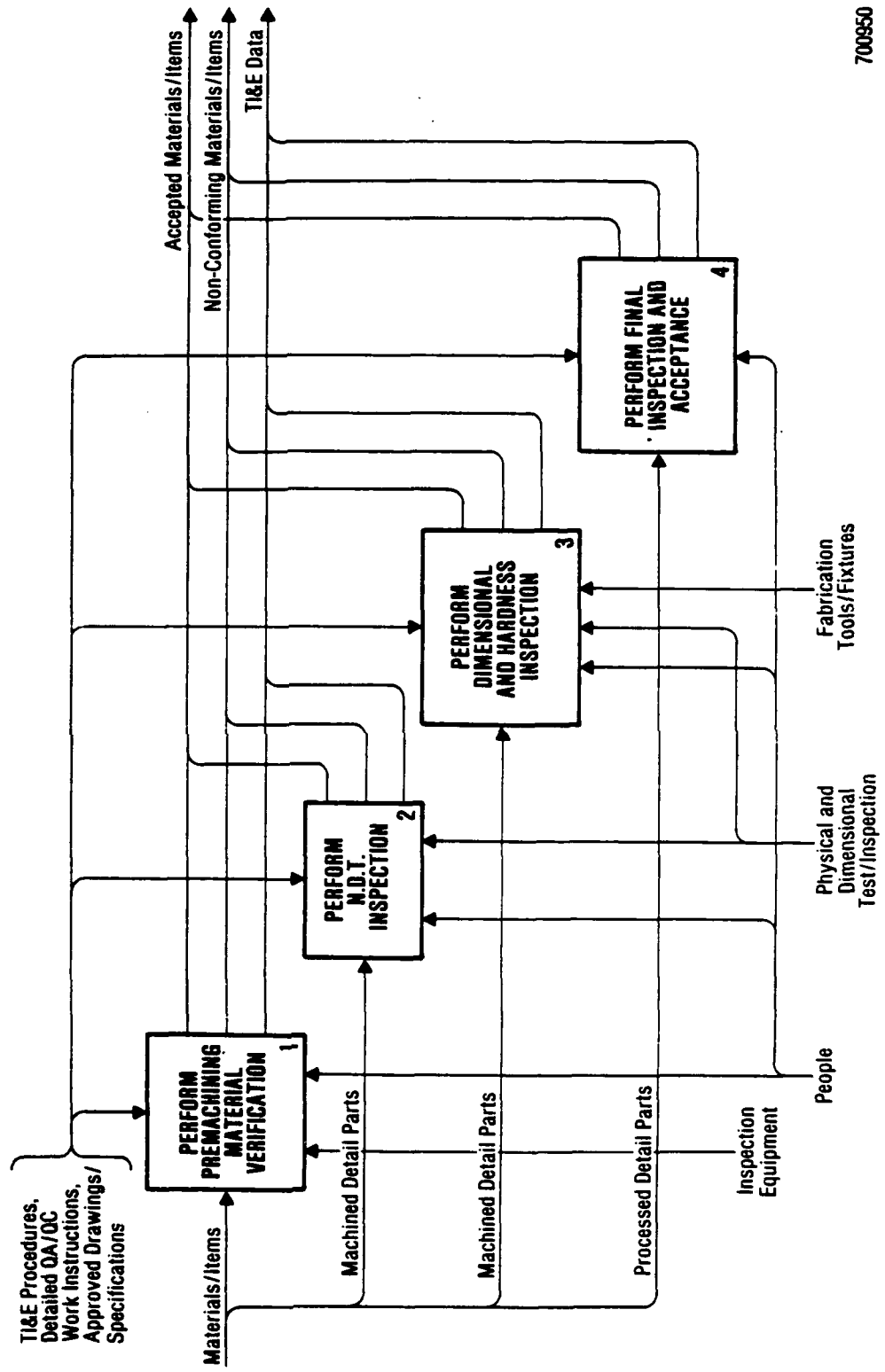

700950

Figure 46D



Delco Electronics

General Motors Corporation
Santa Barbara Operations
6767 Hollister Avenue
Goleta, California 93017

STATEMENT OF WORK

TITLE MECHANICAL INSPECTION CELL - ITM PROJECT 12		SW E41-001	AMEND C
PREPARED BY <i>D. Zentgraf</i>	DATE 5/23/85	SHEET 1 OF 4	
APPROVED BY		CONTRACT F33657-80- NO.G-0007	
APPROVED BY		CODE IDENT NO 13160	

AMENDMENT LCG

AMEND	DESCRIPTION	AUTHORITY	DATE	APVD
A	ADDED SECTIONS 2.1.2.4, 2.1.2.5 REVISED PARA 1.2, 2.1.1.5, 2.1.1.6, 2.1.3, 2.1.3.2, 2.1.3.4, 2.1.3.6, 2.1.2.12, 2.1.2.13	DZ	6-12-85	
B	REVISED PARA 2.1.1.5, 2.1.1.6, 2.1.2.1.1, 2.1.2.2.1, 2.1.2.4.1 2.1.3.2, 2.1.3.3, 2.1.3.6, 2.1.3.8, 2.1.3.9, 2.1.5.1 / ADDED PARA 2.1.2.23, 2.1.2.1.4, 2.2.5.4 / REVISED FIGURE 1	DZ	6-27-85	
C	DELETED PARA 2.7, 2.8, 2.9, 2.1.2.1.4, 2.1.2.2.3 REVISED FIGURE 1	DZ	9-18-85	

NOTE: Technical Directives amending this SOW shall be attached behind this cover sheet.

TABLE OF CONTENTS

1.0	GENERAL
1.1	PURPOSE
1.2	DOCUMENTS
2.0	DESCRIPTION OF ARTICLES AND SERVICES TO BE FURNISHED
2.1	GENERAL
2.1.1	SYSTEMS OBJECTIVES
2.1.2	INSPECTION CELL SUBSYSTEM DEFINITION
2.1.3	SEQUENCE OF OPERATIONS
2.1.4	SYSTEM CYCLE TIME AND THROUGHPUT
2.1.5	EXPANSION CAPABILITY
2.2	OPERATING SYSTEM SOFTWARE
2.2.1	GENERAL REQUIREMENTS
2.2.2	SYSTEM INITIALIZATION
2.2.3	MEASUREMENT OF CONFIGURATION
2.2.4	SYSTEM CALIBRATION
2.2.5	MEASUREMENT DATA STORAGE
2.2.6	INSPECTION REPORTS
2.3	SYSTEM HARDWARE
2.3.1	GENERAL REQUIREMENTS
2.3.2	ENVIRONMENTAL REQUIREMENTS

1.0 SCOPE

1.1 PURPOSE

This specification outlines equipment requirements for an automated mechanical inspection cell to be used in a Receiving and Inspection department (see Figure 1). This inspection cell shall utilize machine vision and robotic technologies to accomplish this task.

1.2 DOCUMENTS

The following government standards, specifications, and regulations, issued in effect on the date of this contract, or as otherwise stated herein, shall form a part of this statement of work to the extent specified.

Sound Level Specification	GM spec SL1.0
Robotic Safety Standards	Section 28
Basic Electrical Standard	ES1
Screw Thread Standard	FED-STD-428/6
GM Manufacturing Automation Protocol	MAP
Engineering Exhibit	EE-75-S-989

2.0 DESCRIPTION OF ARTICLES AND SERVICES TO BE FURNISHED

2.1 GENERAL

2.1.1 SYSTEM OBJECTIVES

2.1.1.1 The mechanical inspection cell shall use automatic vision and robotic systems to inspect a part for all features normally accomplished manually in a receiving/inspection department. Part features would include lengths, widths, heights, feature locations, hole size and depths, tapped hole sizes and depth, angularity, pockets, slots, grooves and any other feature within the capability of the proposed equipment.

2.1.1.2 The inspection cell shall consist of 1) 3-dimensional vision system station to be used for non-contact gaging of mechanical part features; 2) a robot station that would utilize standard go/no-go thread gages to inspect tapped holes; 3) a system supervisory computer to control, transfer, and store data; 4) a material handling robot system to automatically load and unload each station as required; and 5) a safety system.

2.1.1.3 The inspection cell shall have a working envelope (X, Y, Z) of 18 x 24 x 6 inches and a maximum inspected part weight of 12 lbs.

2.1.1.4 Part fixturing requirements shall be semi-dedicated, allowing for common usage between several classes of parts to be inspected. All fixturing shall be manually loaded and unloaded. Detailed fixturing requirements shall be developed during the final systems development.

2.1.1.5 The system shall provide prompting routines for each function which are easily understood without extensive training. These routines must provide the operator with step by step guidance through all phases of system operation including startup, calibration, limit setting, fault recovery, and maintenance.

2.1.1.6 The inspection cell system shall provide for operator override, data processing, act as a functional/maintenance/safety monitor, and store and control all internal and external data flow. Upon completion of an inspection sequence it would store all results and print out any out-of-tolerance part features and make acceptance or rejection decisions.

2.1.2 INSPECTION CELL SUBSYSTEMS DEFINITION

2.1.2.1 DIMENSIONAL MEASUREMENT STATION

2.1.2.1.1 The 3-dimensional vision system that adequately fulfills the requirements of this inspection cell is a View Engineering Model 1200. It consists of 1) a System Control Unit (SCU), 2) a Data Gathering Unit (DGU), and 3) a part position monitor. A vision system equivalent to the View 1200 may be used.

2.1.2.1.2 The SCU handles overall control of the vision measurement system. It includes a TV monitor, keyboard, two floppy disk drives (638K each), one 10-megabyte hard disk, and an 8086/8087 16-bit CPU. Data is downloaded to it from the primary computer and supplied software along with built-in algorithms instruct the DGU to perform all required inspections.

2.1.2.1.3 The DGU accomplishes the actual data measurement. It utilizes a high resolution video camera system mounted in the Z axis and an X-Y servo-motor-driven table onto which the part to be inspected is mounted. Since the X and Y dimensions are in the same plane, the planar dimension is established by the distance the table travels plus the camera's interpretation of the edge of the surface feature being inspected. A built-in algorithm establishes the planar dimension that has been checked. The dimension along the Z axis is a function of the focal length of the camera. One plane is established as the zero or reference point, with the next being a new plane requiring a new focal length. The distance the fixed focal length camera moves along a Z axis determines the Z dimension of the part features being examined.

- 2.1.2.1.4 System accuracy requirement shall be $\pm .00025$ inches minimum in all axes.
- 2.1.2.2 THREAD INSPECTION STATION
 - 2.1.2.2.1 Tapped hole inspection will be accomplished by using Robotic Thread Gaging. This system consists of a robot, robot controller, and end effector tooling that will use go/no-go thread gages to inspect threaded holes (#2 through 1/4 inch) for correct size, class and thread length.
 - 2.1.2.2.2 End effector tooling shall contain a motorized spindle (if not supplied with robot) capable of driving thread gage tooling, a torque sensor, and a rotational measurement device. The end effector shall be capable of sensing go/no-go torque conditions consistent with standard tapped hole inspection processes per FED-STD-428/6.
 - 2.1.2.2.3 Alignment of the end effector tooling to the tapped hole shall be adequate enough to guarantee that 95% of any torque monitored will represent true torque values and not be due to side loading.
 - 2.1.2.2.4 The end effector shall have a rotational position accuracy of $\pm 45^\circ$.
 - 2.1.2.2.5 The end effector shall have automatic tool changing capability.
- 2.1.2.3 SAFETY SYSTEM
 - 2.1.2.3.1. The inspection cell shall have a safety system that will automatically shut down all operations in areas accessible by operating robots when entered by any person. Alarm annunciators shall be provided to indicate the occurrence of a safety violation.
 - 2.1.2.3.2 A flashing indicator light will be on when the system is operating.

2.1.2.4 MATERIAL HANDLING ROBOT

2.1.2.4.1 A material handling robot system shall be designed into the inspection cell to accommodate parts transfer between the in/out, Thread Inspection, and Dimensional Inspection Stations. During an inspection sequence, it will also facilitate part reorientation when commanded by the system's controller. This robot system will also be required to act as a parts platform for the Thread Inspection Station minimizing the requirement for worksurface tooling.

2.1.2.4.2 The material handling robot system shall consist of a robot(s), controller, and end-of-arm tooling (EOAT). This system shall be capable of delivering a part (12 lbs. maximum) to worksurface tooling with sufficient positional accuracy to insure that a smooth and non-binding condition occurs.

2.1.2.4.3 The EOAT shall have an automatic tool change capability and will be designed to handle a family of parts minimizing any unique part handling conditions.

2.1.2.5 SYSTEM SUPERVISORY COMPUTER (SSC)

2.1.2.5.1 A computer shall be integrated into the inspection cell and will provide for overall cell control. It will be capable of interacting with all other equipment listed within this specification without adversely affecting the inspection cell performance or intended functions.

2.1.2.5.2 The SSC shall provide for operator override, act as a functional/maintenance/safety monitor, and store and control all data entering or leaving the inspection cell. The computer's inspection data base will also have a manual programming capability.

2.1.3 SEQUENCE OF OPERATIONS

During the initial development phase it will be assumed that all part fixturing will be manually loaded into each station of the inspection cell. Typical sequence of events for a part requiring both dimensional and tapped hole inspection is summarized below. Detailed part transfer requirements shall be developed during final systems development.

2.1.3.1 SSC is loaded with a program.

2.1.3.2 Application program required for dimensional inspection is downloaded to the dimensional inspection station System Control Unit. The part is transferred to the X-Y platform part fixturing by the material handling robot.

2.1.3.3 The dimensional inspection sequence is started.

2.1.3.4 Prompting of the material handling robot by the computer will be desired if part orientation changes are required.

- 2.1.3.5 After inspection of the part is complete, data is transferred back to the SSC.
- 2.1.3.6 Parts are then transferred from the Dimensional Inspection station and refixed onto the Thread Inspection Station work surface (or held by material handling robot).
- 2.1.3.7 The tapped hole inspection is started.
- 2.1.3.8 Robot will select proper thread gage per downloaded application program.
- 2.1.3.9 Robot will center tooling wih tapped hole. Located on the hand of the robot is a 6 axis force sensor which in addition to measuring torque can sense the required compliance to reposition the robot. This will minimize any binding experienced by the tooling and thereby give truer torque measurements.
- 2.1.3.10 When centering of the thread gaging and tapped hole is accomplished the drive motor will be commanded to reverse rotate for 1.5 turns. This will insure that the gage and the part being inspected are not cross threaded.
- 2.1.3.11 Thread gaging begins. Gage is driven into part while torque is monitored.
- 2.1.3.12 Should gage meet resistance (increased torque), motor would be commanded to stop. Depending on whether the gaging is "go" or "no-go", a decision would have to be made. If a "go" gage is used the system would reverse and count the number of revolutions it takes to extract the tooling, thus determining the thread length. If a "no-go" gage is used, it should meet resistance by the third entry revolution. (The system will be required to inspect as many as eight standard and helicoid thread sizes per part [#2, #4, #6, #8, 2 @ #10, 2 @ 1/4"] with each possibly of being a Class 2 or Class 3 thread. A "go" and "no-go" gage is required for each condition [64 gages total]).
- 2.1.3.13 Material handling robot prompting by the controller will be required if part orientation changes are required.
- 2.1.3.14 After completion of a particular gage size inspection sequence the controller will command a tool change and the inspection process continues until the part is fully inspected.
- 2.1.3.15 After part inspection is complete, all data is transferred from the robot to the SSC and an inspection report printout identifying all discrepancies for the part is generated.

2.1.4 SYSTEM CYCLE TIME AND THROUGHPUT

The system throughput must be sufficient to complete each inspection cycle on a continuous basis. The inspection cycle shall include the following:

- a. Sensor Image Formation and Transmission
- b. Image Processing
- c. Feature Measurement and Associated Calculations
- d. Tapped Hole Gaging Data
- e. Storage of Measurement Data
- f. On-Line Reports: Individual Inspection Reports generated (printed) at a sufficient throughput to maintain report synchronization (real time) with the parts as they exit from the inspection cell or substations.

2.1.5 EXPANSION CAPABILITY

2.1.5.1 The inspection system shall be designed to include an expansion capability. This expansion shall be accomplished through the addition of dimensional inspection, vision, robotic thread inspection and/or material handling robots. The expansion shall not involve the replacement of existing computers or inspection equipment.

2.1.5.2 The inspection system shall be capable of receiving operational data from an intraplant network and returning measurement data to that network. The electrical standard shall be IEEE-802 token passing bus or as minimum RS-422. The protocol shall be the GM MAP standard which is based on current ISO, IEEE and NBS standards for local area networks.

2.2 OPERATING SYSTEM SOFTWARE

2.2.1 GENERAL REQUIREMENTS

2.2.1.1 The system software shall include an interactive operating system which guides the operator through each of the inspection station functions. The operating system shall provide a menu of selectable system functions. Prompting routines which are easily understood shall be used to direct the operator in a step by step manner through the completion of each system function.

2.2.2 SYSTEM INITIALIZATION

2.2.2.1 The system shall perform diagnostic checks on all computer and processing equipment including CPU boards, memory devices, I/O interfaces (discrete, analog and serial ports), power supplies, sensors and peripheral devices (reference section 2.2.7).

2.2.2.2 A prompting routine shall be provided to direct the operator through the initialization process.

2.2.3 MEASUREMENT CONFIGURATION

2.2.3.1 Configuration data must be stored on a non-volatile memory device that is readily available for alteration and can be loaded directly during system initialization reference section 2.2.2.

2.2.3.2 Dimensional measurement programs required per section 2.1.2.1 dimensional measurement station.

2.2.3.3 Tapped hole measurement programs required per section 2.1.2.2 tapped hole inspection station.

2.2.4 SYSTEM CALIBRATION

2.2.4.1 The manpower and level of technical expertise to perform system calibration must be plant personnel compatible and shall not require assistance. Calibration procedures shall be automatic and must be designed for easy implementation under the limited time constraints associated with production conditions.

2.2.4.1 Set up and system calibration data must be stored on a non-volatile memory device that is readily available for alteration, can be loaded directly during system initialization (reference section 2.2.2) and can be accessed for verification, replacement or recalibration functions.

2.2.5 MEASUREMENT DATA STORAGE

The measurement data produced by the inspection station must be stored in a data base which meets the following system requirements.

2.2.5.1 Capacity for 150 dimensioned features per part, at an inspection rate of 100 parts per day over a five day period.

2.2.5.2 Part number, serial number, title, lot number and program code shall identify each part inspected. Each of these identifiers shall not exceed a 25 alpha/numeric character.

2.2.5.3 Date and time of system operation.

2.2.5.4 Upon completion of an inspection sequence, a data field shall be created that contains all the necessary information for report generation.

2.2.6 INSPECTION REPORTS

2.2.6.1 The generation of inspection reports for each part shall be sufficient to maintain report printing synchronization (real time) with each part as it indexes from the inspection cell. Reports shall also be made available if requested manually.

2.2.6.2 All reports shall be available for output in either the systems console (CRT) or printer.

2.2.6.3 Individual inspection reports shall contain:

	<u># OF ALPHANUMERICS</u>
a. Identifier	19
b. Program Number	10
c. Serial Number	7
d. RIP Number	7
e. Defect Code	10
f. Date and Time	11
g. Inspection point discrepancies	(sec. 2.2.5.1)

2.3 SYSTEM HARDWARE

2.3.1 GENERAL REQUIREMENTS

2.3.1.1 The system shall conform to Delco Systems electrical specifications and workmanship standards.

2.3.1.2 Readily available (off the shelf) materials and components shall be used wherever possible. Any single source items used in the system must be clearly identified and a statement of availability supplied.

2.3.1.3 Troubleshooting shall be facilitated by the following considerations.

- a. Self-diagnostics that provide fault detection and reporting down to the major component level.
- b. Easy access to all mechanical and electrical components.
- c. Minimization of unique board proliferation.
- d. Attention to modular design

2.3.1.4 The system console (CRT) and printer must be mounted in enclosures which meet all of the environmental conditions stated in this specification.

2.3.1.5 All enclosures must have an automatic disconnect feature which disengages power when the internal enclosure temperature reaches the manufacturer's specified limit of the device most sensitive to elevated temperature. The power disconnection feature must be designed to provide a controlled power shut-down, which maintains the integrity of the inspection cycle that is in process at the time the power failure occurred.

2.3.1.6 On power up and power down conditions, all outputs shall hardware default to a safe off state and remain so until commanded differently from the controlling processor.

2.3.1.7 All dc power supply outputs shall have short circuit, overvoltage protection and adequate filtering.

2.3.1.8 There shall be an additional 120 VAC, 10 amp rated wall duplex receptacle for powering test equipment, etc., fused separately from the main circuit breakers, noise isolated from the computer/processing equipment and mounted inside the main control enclosure.

2.3.1.9 All receptacles, fuses, indicators, modules, circuit boards and test points shall be permanently labeled.

- 2.3.1.10 All PROM based computer/processors shall have on-line PROM checksum error detection.
- 2.3.1.11 Provisions shall be made to attach 4 AWG ground strap between all panels and subpanels to earth ground.
- 2.3.1.12 The main operating system computer must have a hardware real time clock.
- 2.3.2 ENVIRONMENTAL REQUIREMENTS
 - 2.3.2.1 The inspection system must operate at full accuracy under the environmental conditions of the Receiving/Inspection Department, including the following.
 - a. Ambient temperature range of 62°F to 90°F.
 - b. Humidity levels from 30% to 100% (non-condensing).
 - c. Airborne contaminants such as dust and oils.
 - d. RFI and EMI electrical noise both conducted and radiated.
 - 2.3.2.2 Plant power source supplying standard 120 VAC AND 220 VAC.

I N S P E C T I O N R E S U L T S

PN: 7568174-001
 SN: 00000001
 RIP: 00000001

Inspection Date: 13/02/00
 Inspection Time: 10:25

Current Date: 13/02/00
 Current Time: 10:33

ITEM NUMBER	DIMENSION	NOMINAL	TOLERANCE (+/-)	ACTUAL	DEVIATION (Act-Nom)	THREAD DEPTH (in)		THREAD SIZE
						Nominal Tol. (+/-)	Actual	
14	X (in)	5.8188	.0004	5.8189	.0000	.20	.01	6-32 2B
	Y (in)	14.8685	.0004	14.8690	.0005			
	Z (in)	.3157	.0100	.3045	-.0111			
	THETA(deg)	90.0000	.0085	90.0009	.0009			
15	X (in)	5.8102	.0004	5.8103	.0000			
	Y (in)	13.6498	.0004	13.6503	.0005			
	Z (in)	.6307	.0100	.6266	-.0041			
	THETA(deg)	76.2160	.0085	76.2139	-.0020			
16	X (in)	5.7979	.0004	5.7980	.0000			
	Y (in)	12.4954	.0004	12.4959	.0004			
	Z (in)	1.2948	.0100	1.2962	.0014			
	THETA(deg)	60.9140	.0085	60.9119	-.0020			
17	X (in)	5.7875	.0004	5.7876	.0000			
	Y (in)	11.3767	.0004	11.3771	.0004			
	Z (in)	2.4479	.0100	2.4516	.0036			
	THETA(deg)	42.8670	.0085	42.8599	-.0070			
18	X (in)	5.7799	.0004	5.7800	.0000			
	Y (in)	10.8054	.0004	10.8058	.0004			
	Z (in)	3.6130	.0100	3.6185	.0054			
	THETA(deg)	28.0260	.0085	28.0219	-.0040			
19	X (in)	5.7755	.0004	5.7756	.0000			
	Y (in)	10.4887	.0004	10.4891	.0004			
	Z (in)	5.1757	.0100	5.1818	.0061			
	THETA(deg)	9.9650	.0085	9.9639	-.0010			
20	X (in)	5.7746	.0004	5.7747	.0000			
	Y (in)	10.6394	.0004	10.6398	.0004			
	Z (in)	6.0206	.0100	6.0188	-.0018			
	THETA(deg)	.4620	.0085	.4619	-.0000			
21	X (in)	5.7746	.0004	5.7747	.0000			
	Y (in)	10.7553	.0004	10.7557	.0004			
	Z (in)	6.0603	.0100	6.0594	-.0008			
	THETA(deg)	.0000	.0085	-.0000	-.0000			
22	X (in)	5.7746	.0004	5.7747	.0000			
	Y (in)	20.3815	.0004	20.3823	.0008			
	Z (in)	6.0583	.0100	6.0594	.0011			
	THETA(deg)	.0000	.0085	-.0000	-.0000			

PROGRAM TI_V2

VAR

TAP_SIZE:INTEGER -- CURRENT TAP SIZE
PATH_LEN:INTEGER -- CURRENT PATH LENGTH
PITCH:INTEGER -- THREAD PITCH
DEPTH:REAL -- DEPTH OF THREAD TO BE TESTED
P1:POSITION -- DUMMY POSITION VARIABLE
PFLAG:INTEGER -- PFLAG=1 INSPECT A TAPPED HOLE, PFLAG=0:MOVE ONLY
D:INTEGER
CLOCK:INTEGER
X,Y,Z,W,P,R,E,F,T:REAL
XX:REAL
YY:STRING[22]
VAR1:STRING[4]
MS:REAL -- MS IS THE NUMBER OF ROTATIONS/SEC OF EOAT MOTOR
PERCH:POSITION

-- THIS ROUTINE SETS THRESHOLD IN TORQUE COMPARATOR CIRCUIT
ROUTINE SET_THRESH(TAP_SIZE:INTEGER) FROM TI_V2EXT

ROUTINE CHANGE_TAP -- CHANGES EOAT TAP. CALLED FROM MAIN
BEGIN

-- NOT YET IMPLEMENTED

--WRITE F5 ('CURRENT TAP SIZE: ',TAP_SIZE,CR)

--WRITE F5 ('CURRENT PATH LEN: ',PATH_LEN,CR)

--WRITE F5 ('THREAD DEPTH: ',DEPTH,CR)

--WRITE F5 ('E: ',E,CR)

--WRITE F5 ('THREAD PITCH: ',PITCH,CR)

END CHANGE_TAP

ROUTINE CALL_MC -- ISSUES EOAT MOTOR CONTROLLER

-- COMMANDS TO INSERT AND EXTRACT TAP. CALLED FROM INSP_HOLE

BEGIN

DOUT[12]=ON

DELAY 250

PULSE DOUT[10] FOR 8

DELAY 250

DOUT[8]=OFF

DOUT[7]=OFF

-- GAGE INSERTION

WRITE F2 (';')

DELAY 250

WRITE F2 ('PR',XX::6::0,;')

DELAY 250

OPEN HAND 2

DELAY 500

WRITE F2 ('DH;')

DELAY 250

PULSE DOUT[10] FOR 8

DELAY 500

-- FIND TIME REQUIRED TO THREAD HOLE

CLOCK=0

CONNECT TIMER TO CLOCK

WRITE F2 ('RG;')

DELAY 5000

CLOSE HAND 2

WHILE DIN[1]=OFF DO

HOLD

ENDWHILE

```

WRITE F2 ('ST;')
DELAY 250
DISCONNECT TIMER CLOCK
-- GAGE EXTRACTION
DOUT[12]=OFF
WRITE F2 (';')
DELAY 250
WRITE F2 ('VM;')
DELAY 250
WRITE F2 ('DH;')
DELAY 250
WRITE F2 ('DF;')
DELAY 250
PULSE DOUT[10] FOR 8
DELAY 250
WRITE F2 ('BG;')
DELAY 1000
UNHOLD
IF (CLOCK/1000. < PITCH*0.0787/MS) THEN
  T = 0.0175*MS*CLOCK/PITCH
  SHIFT(P1,VEC(0.,0.,T))
ELSE
  SHIFT(P1,VEC(0.,0.,2.0))
ENDIF
WITH $SPEED=E MOVE TO P1
WHILE DIN[1]=OFF DO
  HOLD
ENDWHILE
WRITE F2 ('ST;')
DELAY 250
PULSE DOUT[10] FOR 8
DELAY 250
WRITE F2 ('TP;')
READ F2 (YY)
WRITE F5 (YY,CR)
UNHOLD
END CALL_MC

ROUTINE INSP_HOLE  -- INSPECT THREADED HOLE
BEGIN
--WRITE F5 (P1,CR)
XX=PITCH*DEPTH*(-4000.0)
DOUT[9]=OFF  -- MOTOR CONTROLLER HARD RESET INITIALIZATION
SET_THRESH(TAP_SIZE)
SHIFT(P1,VEC(0.0,0.0,5.0))
MOVE TO P1
SHIFT(P1,VEC(0.0,0.0,-5.0))
WITH $SPEED=500./$PRGOVERRIDE MOVE TO P1
CALL_MC
SHIFT(P1,VEC(0.0,0.0,5.0))
MOVE TO P1
END INSP_HOLE

BEGIN
-- OPEN DATA FILES AND INITIALIZE PERTINATE VARIABLES
FOR D=1 TO 13 DO  --CLEAR SCREEN
  WRITE (CR)
ENDFOR

```

```

VAR1='PSTR'
$MOTYPE=LINEAR
$TERMTYPE=FINE
$SPEED=200
MS = 0.25  -- INLAND MOTOR TURNS AT 1/4 RPS
OPEN FILE F2 ('RW,IA','CO:')
OPEN FILE F5 ('RW','DATA.DT')
OPEN FILE F6 ('RO','TAP_DATA.DT')
KCL('COMM SET BAUD CO 300')
PERCH=POS(1030.0,105.0,650.0,-180.0,0.0,-180.0,'N')
MOVE TO PERCH

-- SCAN DATA FILE TO OBTAIN EACH TAP SIZE AND CORRESPONDING HOLES
READ F6 (TAP_SIZE,PITCH,DEPTH,PATH_LEN,D)
WHILE NOT EOF(F6) DO
  $PRGOVERRIDE=D
  E = MS*2540./(PITCH*D)
  CHANGE_TAP
  FOR D=1 TO PATH_LEN DO
    READ F6 (PFLAG,X,Y,Z,W,P,R)
    P1 = POS(X,Y,Z,W,P,R,'N')
    IF (PFLAG=1) THEN
      INSP_HOLE
    ELSE
      MOVE TO P1
    ENDIF
  ENDFOR
  READ F6 (TAP_SIZE,PITCH,DEPTH,PATH_LEN,D)
ENDWHILE

MOVE TO PERCH
CLOSE FILE FS
VAR1='FRDY'
WHILE (VAR1 <> 'FDON') DO
ENDWHILE
VAR1='PDON'
END TI_V2

```

PROGRAM TI_V2EXT

ROUTINE SET_THRESH(TAP_SIZE:INTEGER)

BEGIN

SELECT TAP_SIZE OF

CASE (14) : -- 5.1 IN-OZ

DOUT[1]=OFF

DOUT[2]=OFF

DOUT[3]=ON

DOUT[4]=ON

DOUT[5]=OFF

DOUT[6]=OFF

CASE (10) : -- 3.5 IN-OZ

DOUT[1]=OFF

DOUT[2]=OFF

DOUT[3]=ON

DOUT[4]=ON

DOUT[5]=ON

DOUT[6]=OFF

CASE (8) : -- 3.0 IN-OZ

DOUT[1]=ON

DOUT[2]=OFF

DOUT[3]=OFF

DOUT[4]=OFF

DOUT[5]=OFF

DOUT[6]=ON

CASE (6) : -- 2.5 IN-OZ

DOUT[1]=OFF

DOUT[2]=ON

DOUT[3]=ON

DOUT[4]=OFF

DOUT[5]=OFF

DOUT[6]=ON

CASE (4) : -- 2.0 IN-OZ

DOUT[1]=ON

DOUT[2]=ON

DOUT[3]=OFF

DOUT[4]=ON

DOUT[5]=OFF

DOUT[6]=ON

CASE (2) : -- 1.5 IN-OZ

DOUT[1]=OFF

DOUT[2]=OFF

DOUT[3]=OFF

DOUT[4]=OFF

DOUT[5]=ON

DOUT[6]=ON

ELSE :

ENDSELECT

END SET_THRESH

BEGIN

END TI_V2EXT

```

PROGRAM TI_CAL
VAR
K:STRING[22]
BEGIN
K = 'COMM SET BAUD CO 300' ---MOTOR CONTROLLER
KCL (K)
DOUT[1]=ON
DOUT[2]=ON
DOUT[3]=ON
DOUT[4]=ON
DOUT[5]=ON
DOUT[6]=OFF
DOUT[7]=OFF --ENABLE BUFFER
DOUT[8]=OFF ---- CLEAR BUFFER
DELAY 250
OPEN FILE F1 ('RW,IA','CO:')
WRITE F1 (';')
DELAY 250
WRITE F1 ('VM;')
DELAY 250
WRITE F1 ('PL 0;')
DELAY 250
WRITE F1 ('ZR 254;')
DELAY 250
WRITE F1 ('GN 3;')
DELAY 250
WRITE F1 ('SP 1000;')
DELAY 250
WRITE F1 ('AC 500;')
DELAY 250
WRITE F1 ('DH;')
DELAY 250
WRITE F1 ('PR -12000;')
DELAY 250
PULSE DOUT[10] FOR 8
WRITE F1 ('BG;')
DELAY 8000
DOUT[8]=ON---CLEAR BUFFER
DELAY 250
DOUT[8]=OFF
DELAY 500
DOUT[7]=ON --- ENABLE BUFFER
DELAY 250
DOUT[7]=OFF --- DISABLE BUFFER
DELAY 4000
WRITE F1 ('ST;')
PULSE DOUT[8] FOR 8
DELAY 250
WRITE F1 ('DH;')
END TI_CAL

```

NOTES:

1. INTERPRET DRAWING PER MIL-STD-100.
2. MATERIAL:
ALUMINUM ALLOY
5052 TEMPER H32
SPEC QQ-A-250/8.
3. OPTIONAL MATERIAL:
ALUMINUM ALLOY
6061 TEMPER T6
SPEC QQ-A-250/11.
4. UNLESS OTHERWISE SPECIFIED:
REMOVE ALL BURRS AND BREAK SHARP
EDGES .02 MAX RAD OR CHAMFER.
5. PROTECTIVE FINISH:
CHEMICAL FILM, CLASS I A
SPEC MIL-C-5541.
6. MARK .12 HIGH BLACK CHARACTERS USING ITEM 5.
MARK PER ES 2475 USING METHOD -001 (STENCIL),
OR -005 (RUBBER STAMP) IN APPROXIMATE LOCATIONS
SHOWN.
7. IDENTIFY WITH PART NO 13160-756-002-011 PER MIL-STD-130
USING ITEM 5. MARK PER (ES 267-009 RUBBER STAMP OR,
-001 STENCIL).
8. VENDOR ITEM, SEE CONTROL DRAWING.
9. INSTALL ITEMS 2, 3, & 4 AFTER FINISHING
PER NOTE 5.
10. INSTALLATION OF ITEMS 2 & 3:
A. DO NOT BREAK OR CHAMFER INSTALLATION HOLE
EDGE ON INSERTION SIDE.
B. IF PUNCHED HOLE DIRECTION OF PUNCH SHALL BE
OPPOSITE THAT OF PART INSERTION.
C. WITH REAR SUPPORTED FLARE FRONT OF CLINCH NUT
TO INSURE RETENTION.

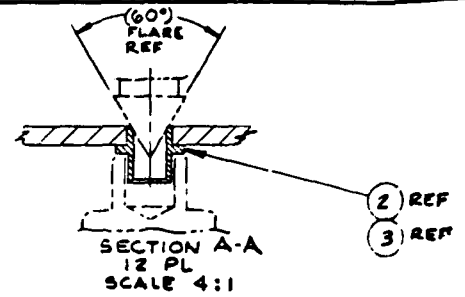

FAR SIDE MARKINGS
SEE NOTE 6

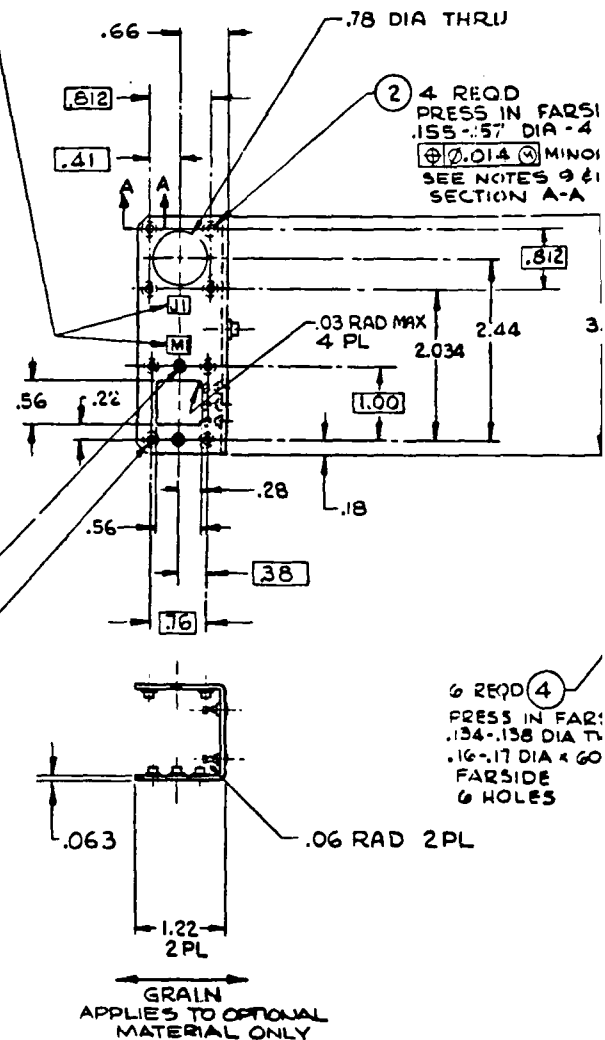

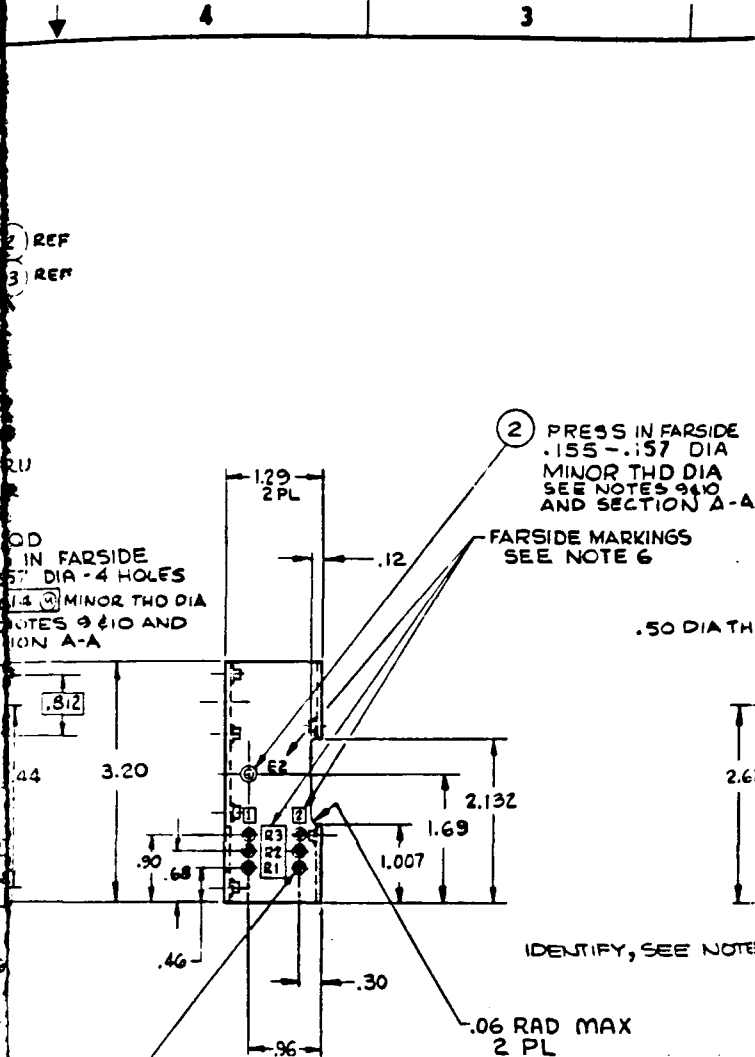

REVISES			DATE	APPROVED
ZONE	LTR	DESCRIPTION	AUTH	
4-C	A	CL II DIM 1.29 WAS 1.286	C	5-16 DT
5-C		① ADDED TRUE POSITION TO .78 DIA. ② ADDED MINOR THD DIA TO TRUE POSITION TOL (ZONE 5-C, 7-A (1-C))	10984	77
8-1	B	CLASS # (1) ADDED ITEM 4 IN TABLE 1 ② RELOCATED HOLES: .46 WAS 1.47 PARTIAL MARKINGS	C	12-1 JRM
0-3	C	CL II DIM IN P/L - ITEM 2 - QTY WAS "B" - ADDED RELATED NOTE # 1.69 DIM.	C	5 DEC 77
F/10	D	CL II RELAX TOLERANCE ② ADD SLOT	C	23 JAN 78
B/C	E	CL II EXTENDED CENTERLINE THRU SQUARE HOLE	C	12463 JUL 78
	F	CL II REVISED REV STATUS BLOCK ① ADDED ITEMS TO P/L NOTES 8 & 7	C	18370 11-7-80
	G	CL II ADDED SECTION A-A ① ITEM 2 WAS 57530-003 ② ITEM 3 WAS 57530-004 ③ ADDED NOTE 10	C	18791 9-8-81

QUANTITY REQD	ITEM	CODE IDENT NO	PART NUMBER	NOMENCLATURE OR DESCRIPTION	SPECIFICATIONS
	AR	5		FLAT BLACK INK, MARKING, EPOXY	MIL-I-43553
	6	4	7597829-001	TERMINAL, STANDOFF	SEE NOTE 8 & 9
	3	3	7564532-007	NUT, SELF-LOCKING, CLINCH	SEE NOTE 8 & 9
	9	2	7564532-004	NUT, SELF-LOCKING, CLINCH	SEE NOTE 8 & 9
	1	1	7561002-001	BRACKET	SEE NOTE 2 & 3

UNLESS OTHERWISE SPECIFIED DIMENSIONS ARE IN INCHES TOLERANCES UNLESS OTHERWISE SPECIFIED

2 PLACE DECIMALS .01 3 PLACE DECIMALS .005 ANGLES 3°

MATERIAL SEE L M

REP C59 CHG CONTROL OTHER APPROVAL

THE PART NUMBER IS THE DRAWING NUMBER AND THE DASH NUMBER THAT APPLIES

7561002-001
Delco Electronics
 GENERAL MOTORS CORPORATION SANTA BARBARA, CALIFORNIA

TITLE **BRACKET - INSEP ASSY**

SIZE CODE IDENT NO. D 13160 7561002
 DASH ACTIVITY APPS. REV. G

SCALE FULL WEIGHT SHEET 1 OF 1

DWG NO. 7561002
 REV. G
 201941

NOTES

1. INTERPRET DRAWING PER DOD-STD.-100.

2. MATERIAL :
ALUM ALLOY CASTING
356 TEMPER TG, QQ-A-596

OPTIONAL MATL :
ALUM ALLOY CASTING
356 TEMPER TG1, QQ-A-596

3. UNLESS OTHERWISE SPECIFIED :
- A. REMOVE BURRS AND BREAK SHARP EDGES .02 MAX RAD OR CHAMFER.
 - B. ALL CAST INTERNAL CORNER RADII .08 MAX.
 - C. ALL CAST EXTERNAL CORNER RADII .03 MAX.
 - D. CAST WALL THICKNESS INCLUDING DRAFT .06-.10
 - E. MAX DRAFT 1°.
 - F. MACHINED SURFACES DENOTED BY √.
4. INSPECT CASTING PER ITEM 7.
5. INSTALL INSERT 3/4-1 1/2 TURNS BELOW SURFACE AND REMOVE TANG PER ITEM 5.
6. IDENTIFY WITH PART NO. 13160-7565015-011 PER ITEM 6.
7. ALL DIMENSIONS APPLY IN AN UNRESTRAINED POSITION.

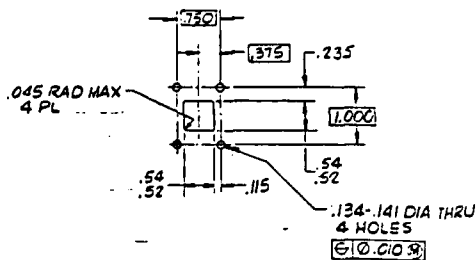

VIEW E
(MACHINED √)

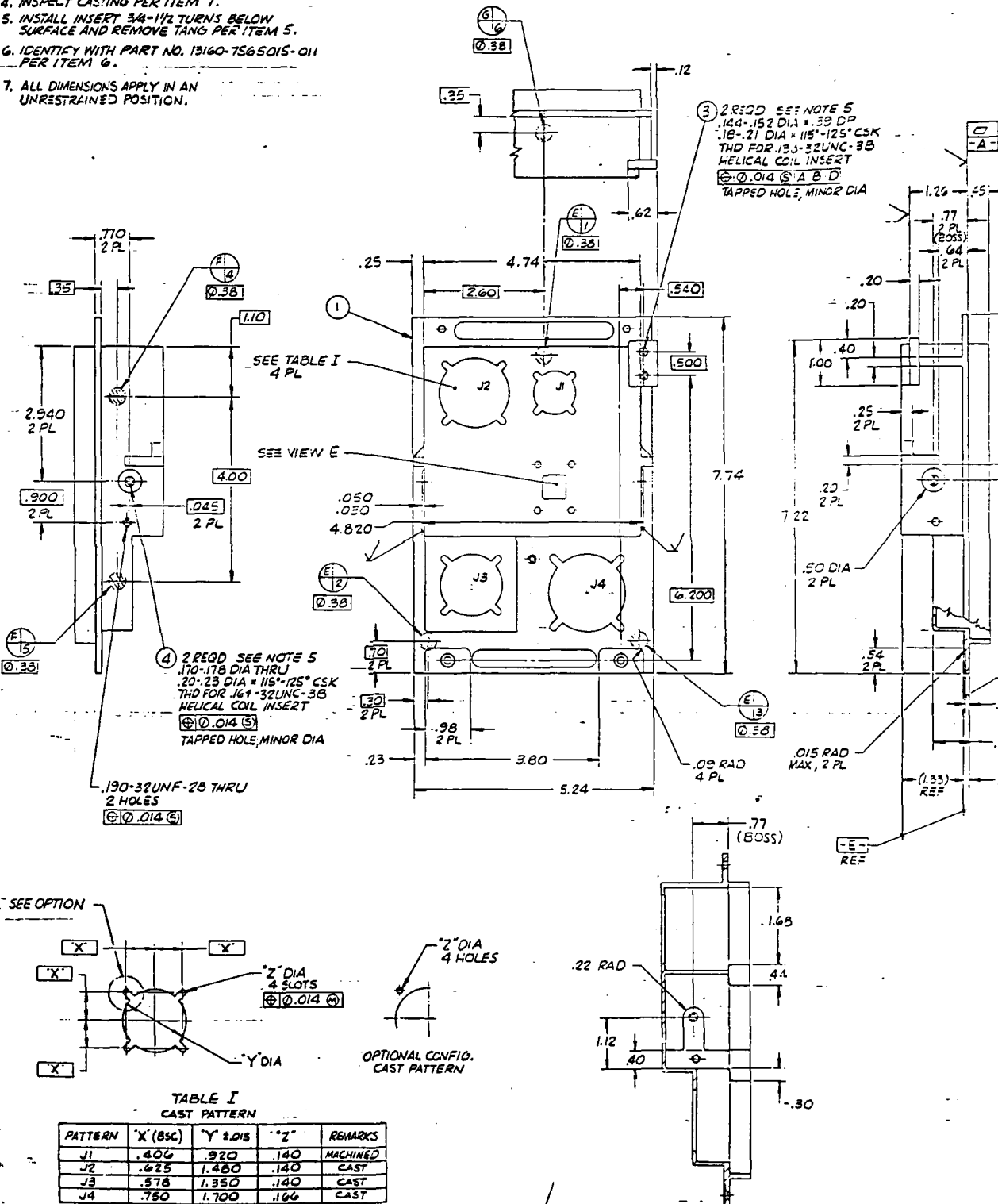

SEE OPTION

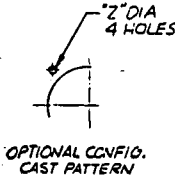
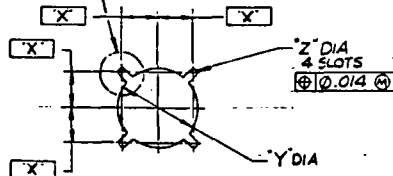
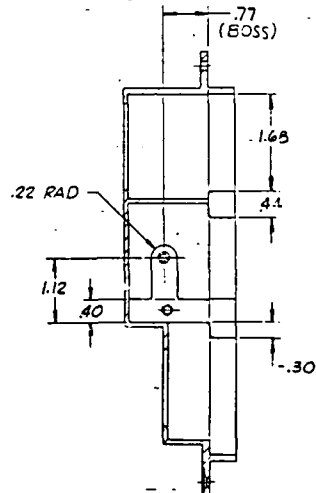

TABLE I
CAST PATTERN

PATTERN	X (BSC)	Y & DIS	Z	REMARKS
J1	.406	.920	.140	MACHINED
J2	.625	1.480	.140	CAST
J3	.576	1.350	.140	CAST
J4	.750	1.700	.166	CAST



SECTION C-C

H
G
F
E
D
C
B
A

8 7 6 5 4

NOTES:

1. INTERPRET DRAWING PER MIL-STD-100.
2. MATERIAL:
ALUMINUM ALLOY
6061 TEMPER T651
SPEC QQ-A-250/11.
3. OPTIONAL MATERIAL:
ALUMINUM ALLOY
2024 TEMPER T351
SPEC QQ-A-250/4.
4. UNLESS OTHERWISE SPECIFIED:
REMOVE ALL BURRS AND BREAK SHARP
EDGES .02 MAX RAD OR CHAMFER.
5. PROTECTIVE FINISH:
CHEM FILM ITEM 5.
6. MARK .12 HIGH BLACK CHARACTERS USING INK (ITEM 7 PER
SPEC ITEM 6 USING METHOD -.001 (STENCIL),
-.002 (SILK SCREEN), OR -.005 (RUBBER STAMP)
IN APPROXIMATE LOCATIONS SHOWN.
7. IDENTIFY WITH PART NO. 13160-DG100034-011 PER
MIL-STD-130 (ES267-009 RUBBER STAMP, -.010
STENCIL, OR -.011 SILK SCREEN).
8. VENDOR ITEM, SEE CONTROL DRAWING.
9. INSTALL ITEM 2, 3, AND 4 AFTER
FINISHING PER NOTE 5.

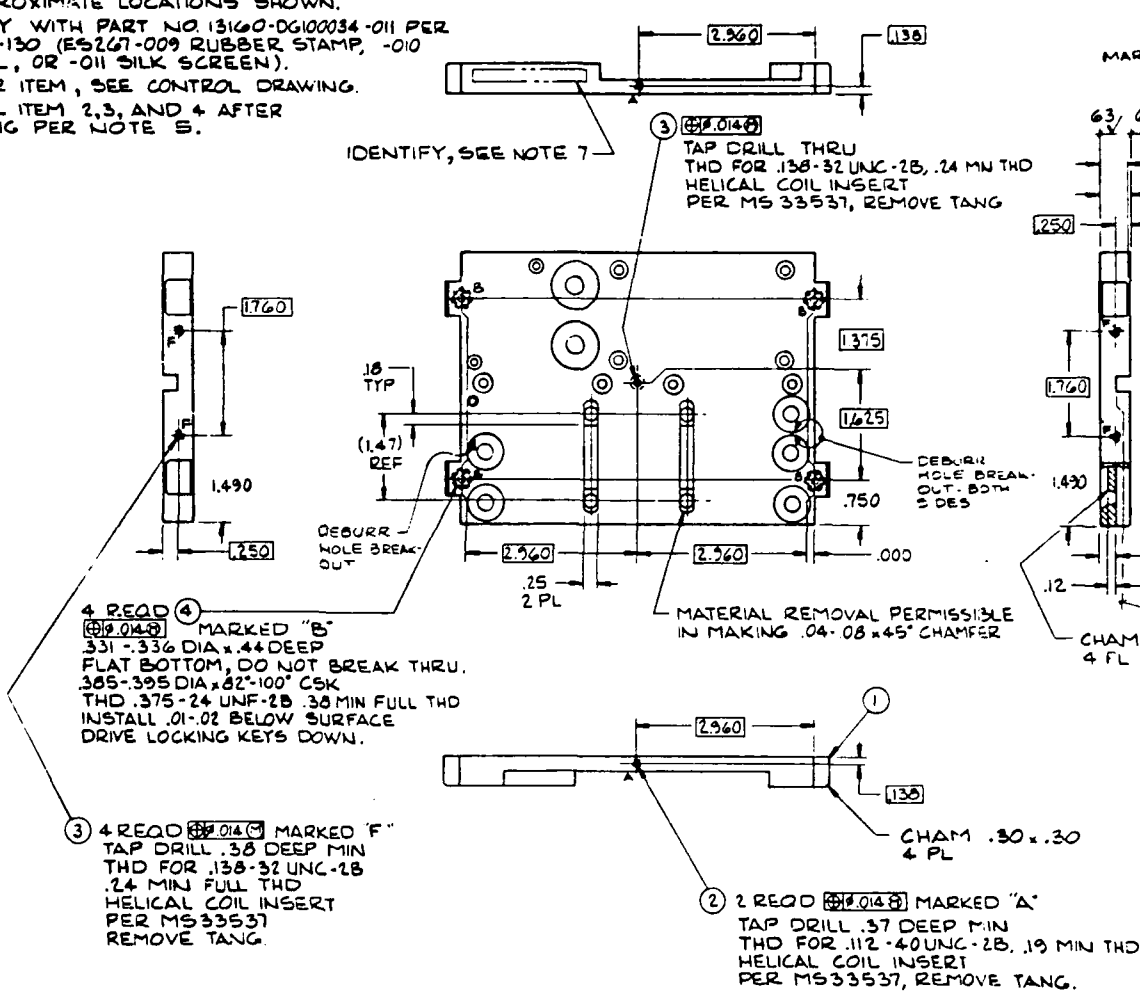

4 REQD (Ø.0148) MARKED "B"
 .331-.336 DIA x .44 DEEP
 FLAT BOTTOM, DO NOT BREAK THRU.
 .385-.395 DIA x .82-.100" CSK
 THD .375-24 UNF-2B .38 MIN FULL THD
 INSTALL .01-.02 BELOW SURFACE
 DRIVE LOCKING KEYS DOWN.

4 REQD (Ø.0148) MARKED "F"
 TAP DRILL .38 DEEP MIN
 THD FOR .138-32 UNC-2B
 .24 MIN FULL THD
 HELICAL COIL INSERT
 PER MS 33537
 REMOVE TANG.

2 REQD (Ø.0148) MARKED "A"
 TAP DRILL .37 DEEP MIN
 THD FOR .112-40 UNC-2B, .19 MIN THD
 HELICAL COIL INSERT
 PER MS 33537, REMOVE TANG.

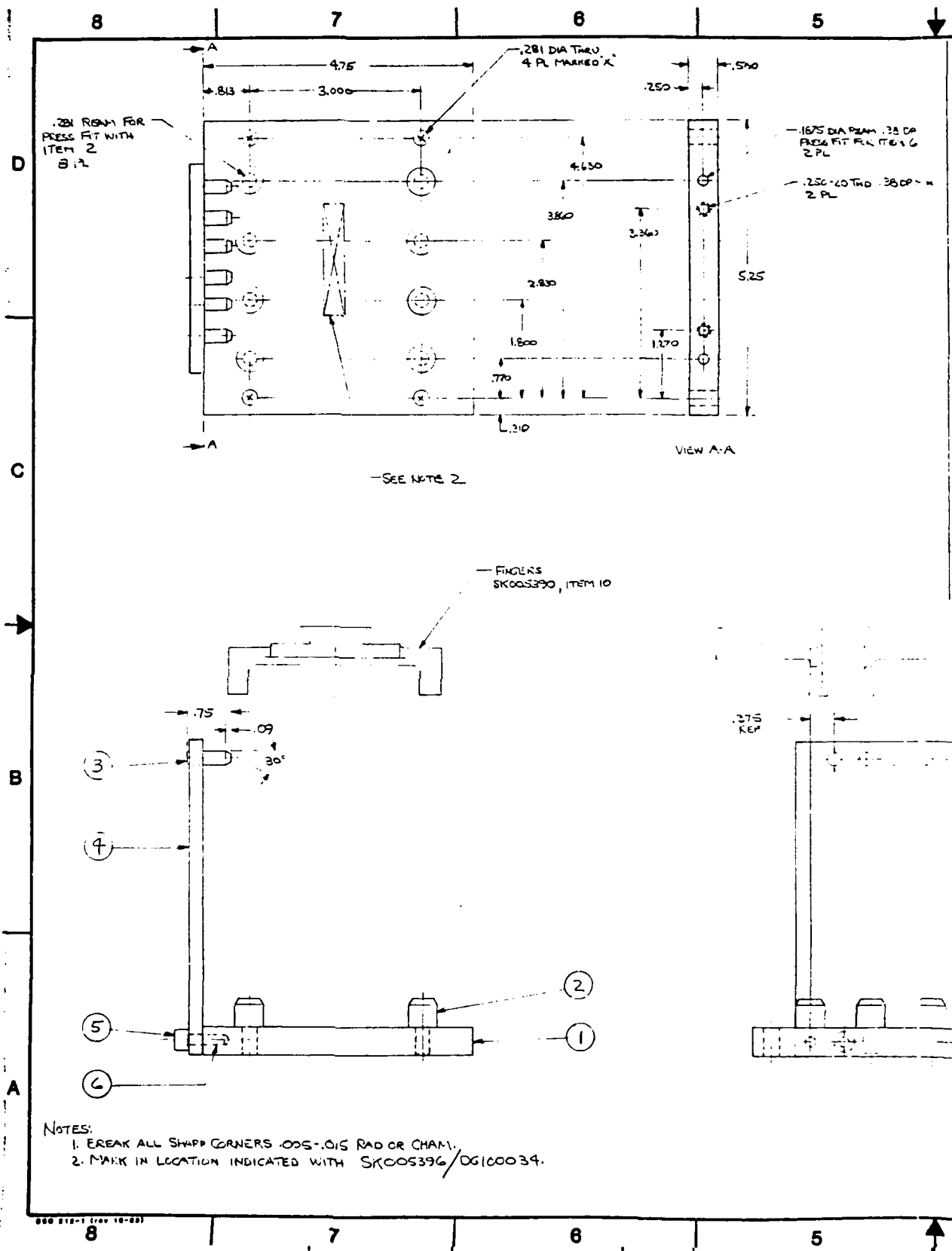

.281 RSHM FOR PRESS FIT WITH ITEM 2

.281 DIA TIEU 4 PL MARKED X

.1675 DIA PLAM .38 DP PRESS FIT FOR ITEM 6 2 PL

.250-20 TWD .38 DP 2 PL

FINGERS SKOOS390, ITEM 10

.275 KEP

NOTES:
 1. BREAK ALL SHARP CORNERS .005-.015 RAD OR CHAM.
 2. MARK IN LOCATION INDICATED WITH SKOOS396/OG100034.

D

C

B

A

8

7

6

5

8

7

6

5

-SEE NOTE 2

VIEW A-A

000 810-1 (REV 10-88)

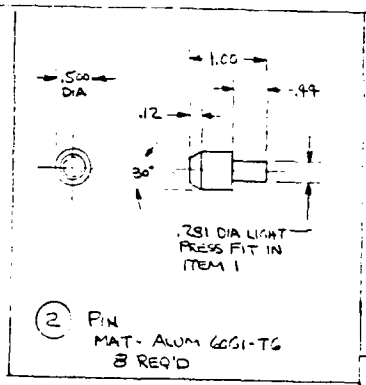
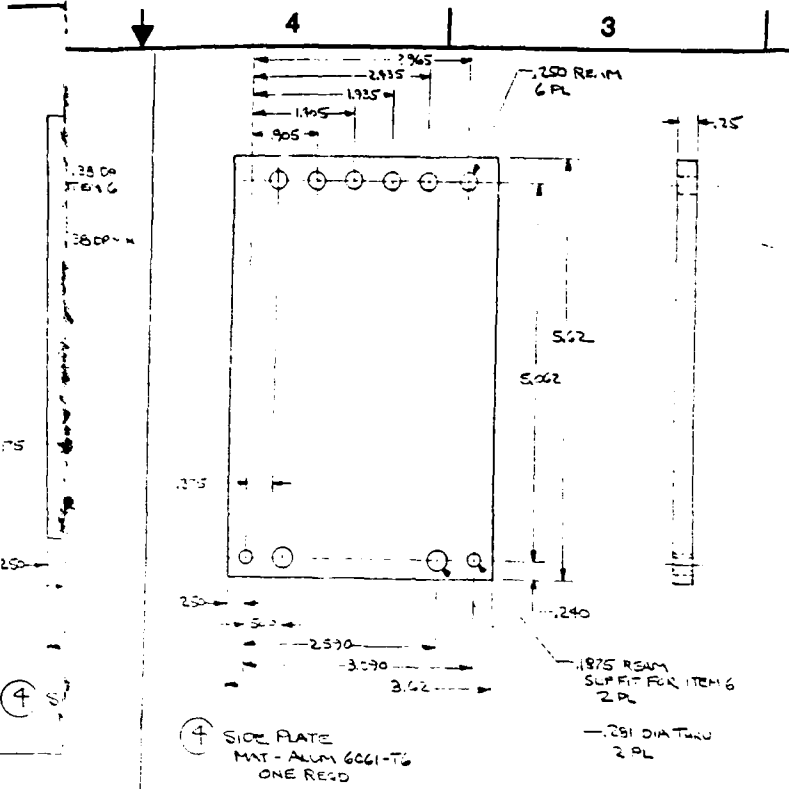

ZONE REV		REVISIONS		
		DESCRIPTION	AUTH.	DATE APPROVED

ITEM REQ'D	DESCRIPTION	MATERIAL
6	2 DOWN	3/16 DIA X 7/8 LG STEEL
5	2	Soc. HD SCR 1/4-20 X 5/8 LG STEEL
4	1	SIDE PLATE 1/4 X 3 7/8 X 5 7/8 ALUM-6061-T6
3	6	PIN-DOWEL 1/4 DIA X 3/4 LG STEEL
2	8	PIN 1/2 DIA X 1 1/4 LG ALUM-6061-T6
1	1	BASE PLATE 1/2 THK X 5 X 5 1/2 ALUM 6061-T6

UNLESS OTHERWISE SPECIFIED DIMENSIONS ARE IN INCHES

TOLERANCES ON
 2 PLACE DECIMALS ±.010
 3 PLACE DECIMALS ±.005
 ANGLES ±1°

MATERIAL

CONTR BY A DRECHSLER 11/1985

CHKD ENGR APVD APVD APVD APVD

OSCR ACTIVITY APVD

INTERPRET DRAWING PER 000 570 100

DO NOT SCALE DWG

REF E-41

Delco Systems Operations
 GENERAL MOTORS CORPORATION GOLETA CALIFORNIA

TITLE
 PALLET RACK FOR PLATE, BACK
 # DG100039

SIZE **D** FSCM NO **13160** DWG NO **SK005396** REV -

SCALE 1:1 SHEET OF 1

e

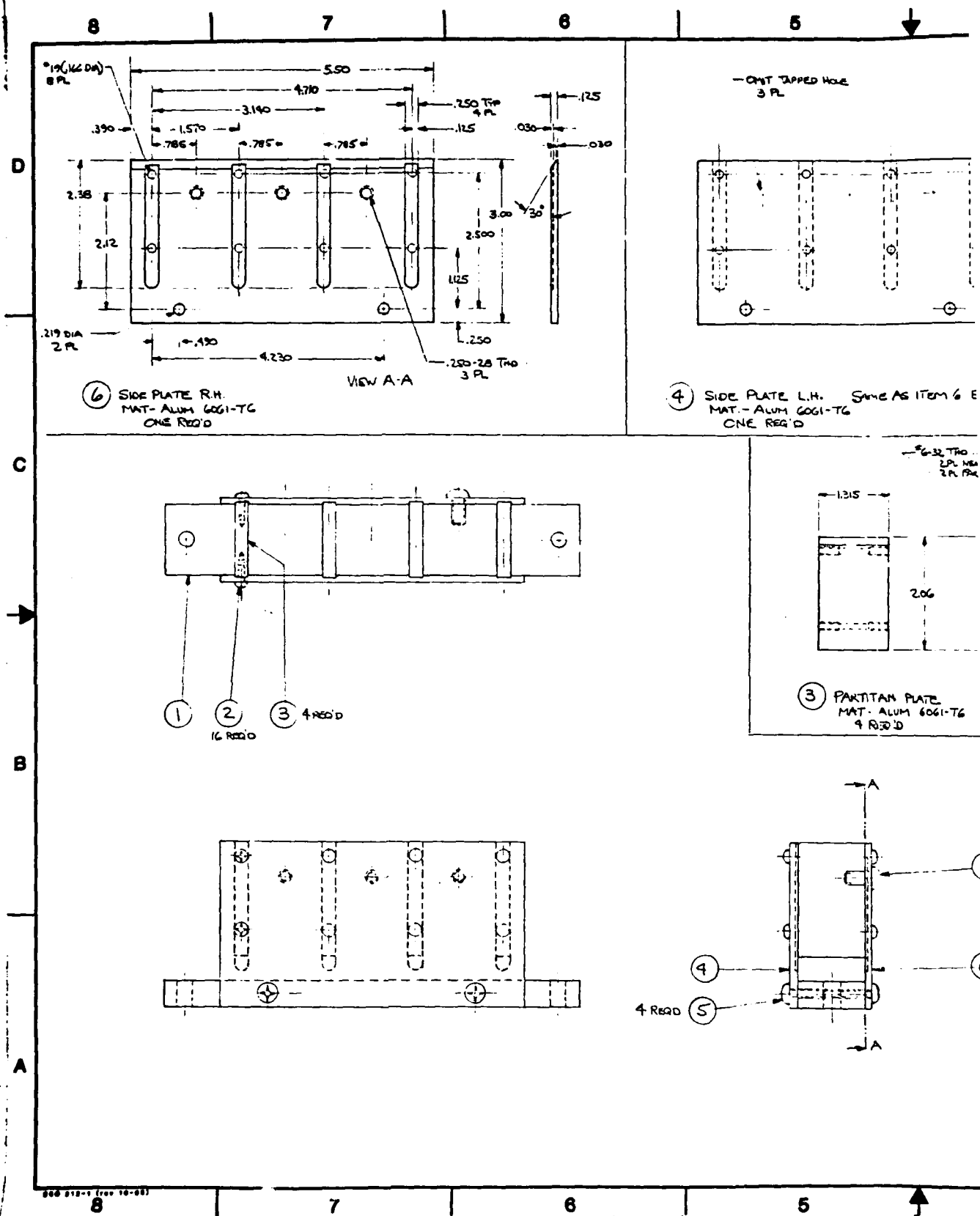

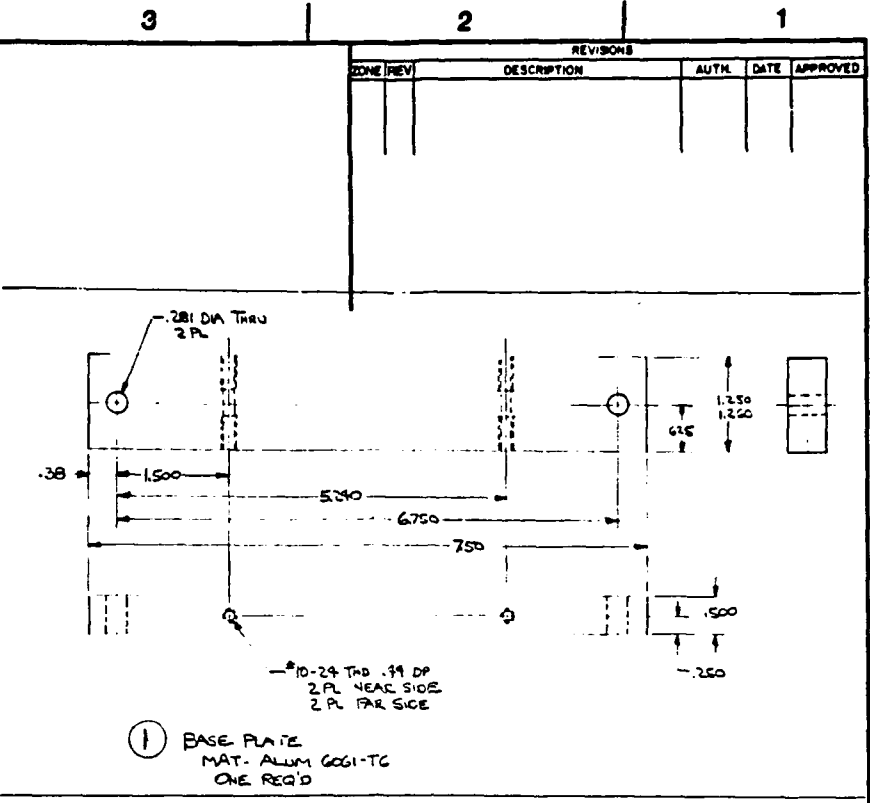
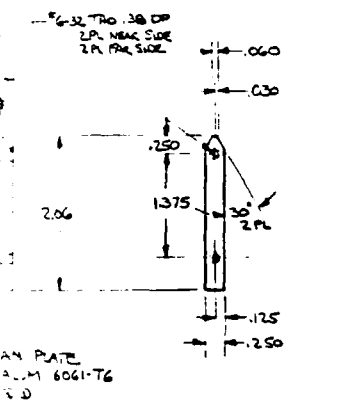
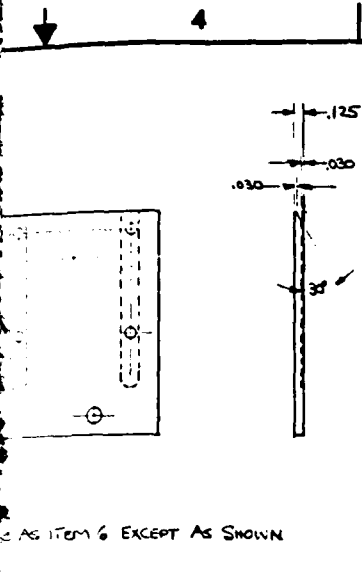

REVISIONS					
ZONE	REV	DESCRIPTION	AUTH	DATE	APPROVED

ITEM	REQ'D	DESCRIPTION	MATERIAL
7	3	PAN NO SCR CROSS RECESSED 1/4-20 X 1/2 LG	
6	1	SIDE PLATE R.H. 1/8 X 3 1/4 X 6 3/4	ALUM 6061-T6
5	4	PAN NO SCR CROSS RECESSED #10-24 X 1/2 LG	
4	1	SIDE PLATE L.H. 1/8 X 3 1/4 X 5 3/4	ALUM 6061-T6
3	4	PARTITION PLATE 1/8 X 1 1/2 X 2 1/4	ALUM 6061-T6
2	16	PAN NO SCR CROSS RECESSED #6-32 X 3/8 LG	
1	1	BASE PLATE 1/2 X 1 1/2 X 7 3/8	ALUM 6061-T6

UNLESS OTHERWISE SPECIFIED DIMENSIONS ARE IN INCHES

TOLERANCES ON
2 PLACE DECIMALS ±.010
3 PLACE DECIMALS ±.005
ANGLES ±2°

MATERIAL

INTERPRET DRAWING PER 000 STD-108

DO NOT SCALE DRG

REV E-41

SCALE 1"=1"

DO NOT SCALE DRG

REV E-41

SCALE 1"=1"

GENERAL MOTORS CORPORATION GOLETA CALIFORNIA

TITLE
PALLET RACK FOR BRACKET 75C100Z

SIZE D 13160
DSCN NO. SK005397
REV -

SHEET 1 OF 1

2

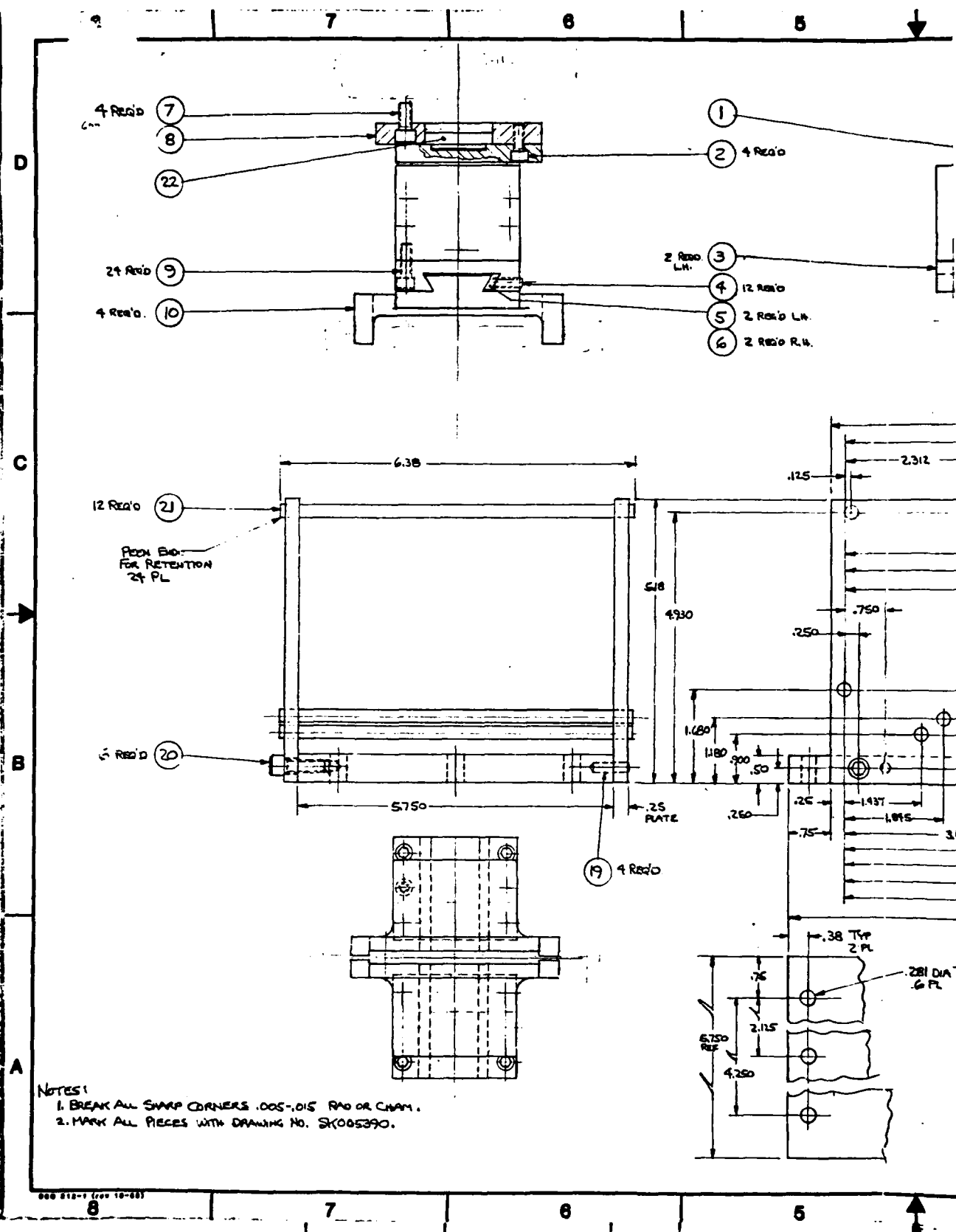

NOTES:
 1. BREAK ALL SHARP CORNERS .005-.015 RAO OR CHAM.
 2. MARK ALL PIECES WITH DRAWING NO. SK005390.

000 512-1 (REV 10-65)

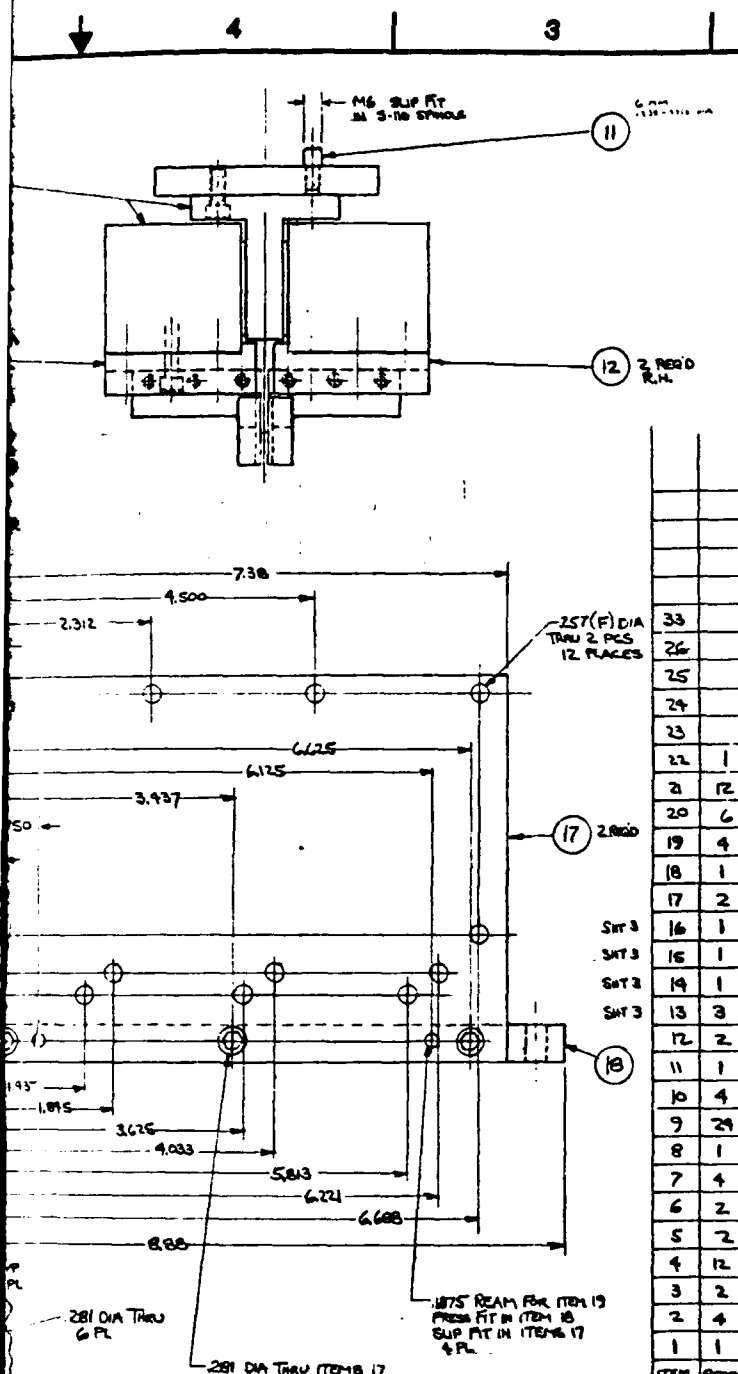

REVISIONS					
ZONE	REV	DESCRIPTION	AUTH.	DATE	APPROVED
A		REVISED SHEETS 1, 2, 3, 4 ADDED ITEM 22 ON SHEET 2	A.C.O.	2/17/78	

ITEM	QTY	DESCRIPTION	MATERIAL
33		SEE SHEET 4 FOR ITEMS 20 THRU 33	
26		SEE SHEET 4 FOR ITEMS 20 THRU 33	
25		SEE SHEET 4 FOR ITEMS 20 THRU 33	
24		SEE SHEET 4 FOR ITEMS 20 THRU 33	
23		SEE SHEET 4 FOR ITEMS 20 THRU 33	
22	1	CENTERING PLUG 1 1/2 DIA X 1/2 LG.	ALUM 6061-T6
21	12	ROD 1/4 DIA X 6 3/8 LG	ALUM OR STEEL
20	6	SEC NO SCR 1/4-20 X 3/4 LG	
19	4	DOWEL PIN 3/16 DIA X 5/8 LG	STEEL
18	1	BASE PLATE 1/2 THICK X 6 X 9 1/2	ALUM 6061-T6
17	2	SIDE PLATE 1/2 THICK X 5 1/2 X 7 1/2	ALUM 6061-T6
SHT 3	16	1 PIN 3/16 DIA X 3/8 LG	DRILL ROD
SHT 3	15	1 NUTS SEC SET SCREW #8-32 X 3/8 LG	
SHT 3	14	1 FINGER 1 1/4 X 2 X 2 1/2	ALUM 6061-T6
SHT 3	13	3 FINGER 1 1/4 X 2 X 2 1/2	ALUM 6061-T6
	12	2 ONE TAIL BLOCK R.H. 3/4 X 2 1/4 X 2 1/2	STEEL 1020
	11	1 DOWEL PIN 1/4 DIA X 1" LG	DRILL ROD
	10	4 FINGER 1 1/4 X 2 1/4 X 4	ALUM 6061-T6
	9	24 SEC. NO SCR #10-24 X 3/8 LG	
	8	1 ADAPTER 3/4 DIA X 1/2 LG	ALUM-6061-T6
	7	4 SEC NO SCR #6 X 1 X 14 MM LG	
	6	2 GB R.H. 1/2 X 1/2 X 2 1/4	STEEL C.R.
	5	2 GB L.H. 1/2 X 1/2 X 2 1/4	STEEL C.R.
	4	12 NUTS SEC SET SCW #10-32 X 1/2 LG	
	3	2 ONE TAIL BLOCK L.H. 3/4 X 2 1/4 X 2 1/2	STEEL 1020
	2	4 SEC NO SCR #10-24 X 1/2 LG	
	1	1 PARALLEL GRIPPER MECHANISM: FLAT-PC-704	FUEL (SEE SHT 1)

THE PART NUMBER IS THE DRAWING NUMBER AND THE DASH NUMBER THAT APPLIES

UNLESS OTHERWISE SPECIFIED DIMENSIONS ARE IN INCHES		DATE: 1/14/78	
TOLERANCES ON 2 PLACES 3 PLACE DECIMALS 3 PLACE ANGLES 1.010 1.005 1.010		GENERAL MOTORS CORPORATION GOLETA, CALIFORNIA	
MATERIAL		TITLE: TOOLING FOR S-110 ROBOT INCLUDES FINGERS FOR 4th AXIS PALLET RACK FOR FRONT PANEL 7550015 MECHANOTRON GRIPPER MOD.	
INTERPRET DRAWING PER 000-STD-109		SIZE: 13180	
DO NOT SCALE DIMS		DASH NO: SK005390	
REF: E-4		REV: A	
SCALE		SHEET 1 OF 4	

SHEET	1	2	3	4				
REV	A	A	A	A				

4 3 2 1

2

8

7

6

5

D

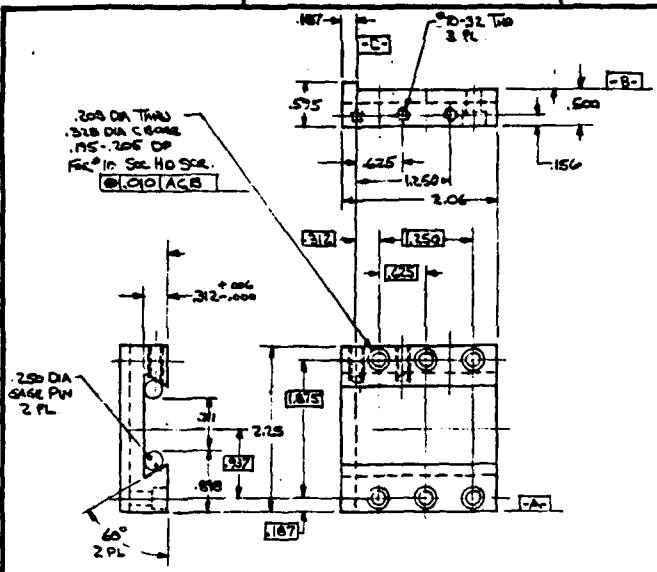

C

(12) DOVE TAIL BLOCK - RIGHT HAND
MAT-1020 STEEL
2 REQ'D.

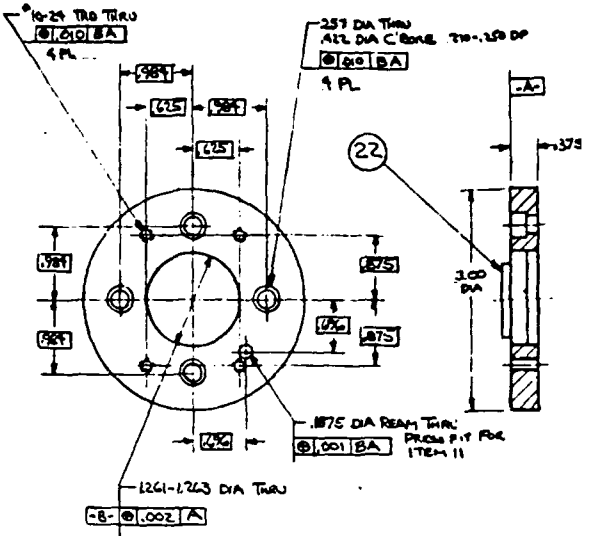

(8) ADAPTER S-110 TO MELANTRON GUPPER
MAT-ALUM 6061-T6
ONE REQ'D

A

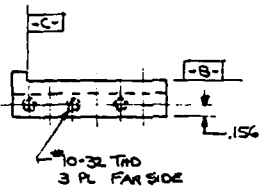

B

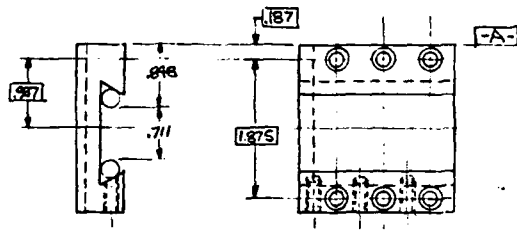

(22) CENTERING PLUG
MAT-ALUM 6061-T6
ONE REQ'D.

(3) DOVE TAIL BLOCK - LEFT HAND
SAME AS ITEM EXCEPT OPPOSITE
HAND AS SHOWN
2 REQ'D

8

7

6

5

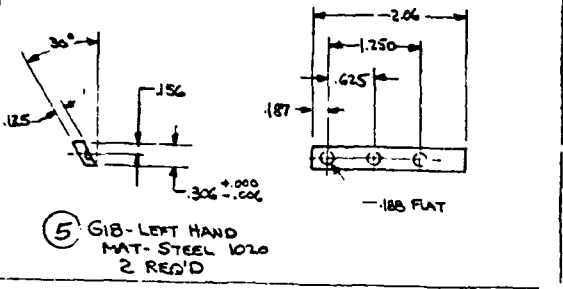
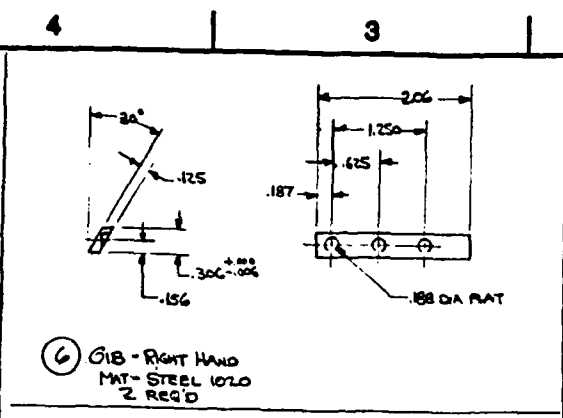
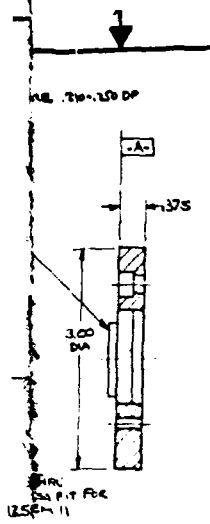

ZONE REV		REVISIONS			
		DESCRIPTION	AUTH.	DATE	APPROVED

THE PART NUMBER IS THE DRAWING NUMBER AND THE DASH NUMBER THAT APPLIES

UNLESS OTHERWISE SPECIFIED DIMENSIONS ARE IN INCHES TOLERANCES ON 3 PLACE 3 PLACE ANGLES DECIMALS DECIMALS ±.010 ±.006 ±.1°	COUNTRY		Delco Systems Operations		
	BY	CHKD	GENERAL MOTORS CORPORATION COLETA, CALIFORNIA		
	ENGR	ENGR	TITLE		
	APVD	APVD			
MATERIAL	APVD	APVD			
	DESIGN ACTIVITY	APVD			
INTERPRET DRAWING PER DOD-STD-108	DO NOT SCALE DWG	REV E-11	SIZE D	PICW NO. 13160	DWG NO. SK005390
			SCALE		SHEET 2 OF 4

D
C
B
A

4
4
3
2
1

2

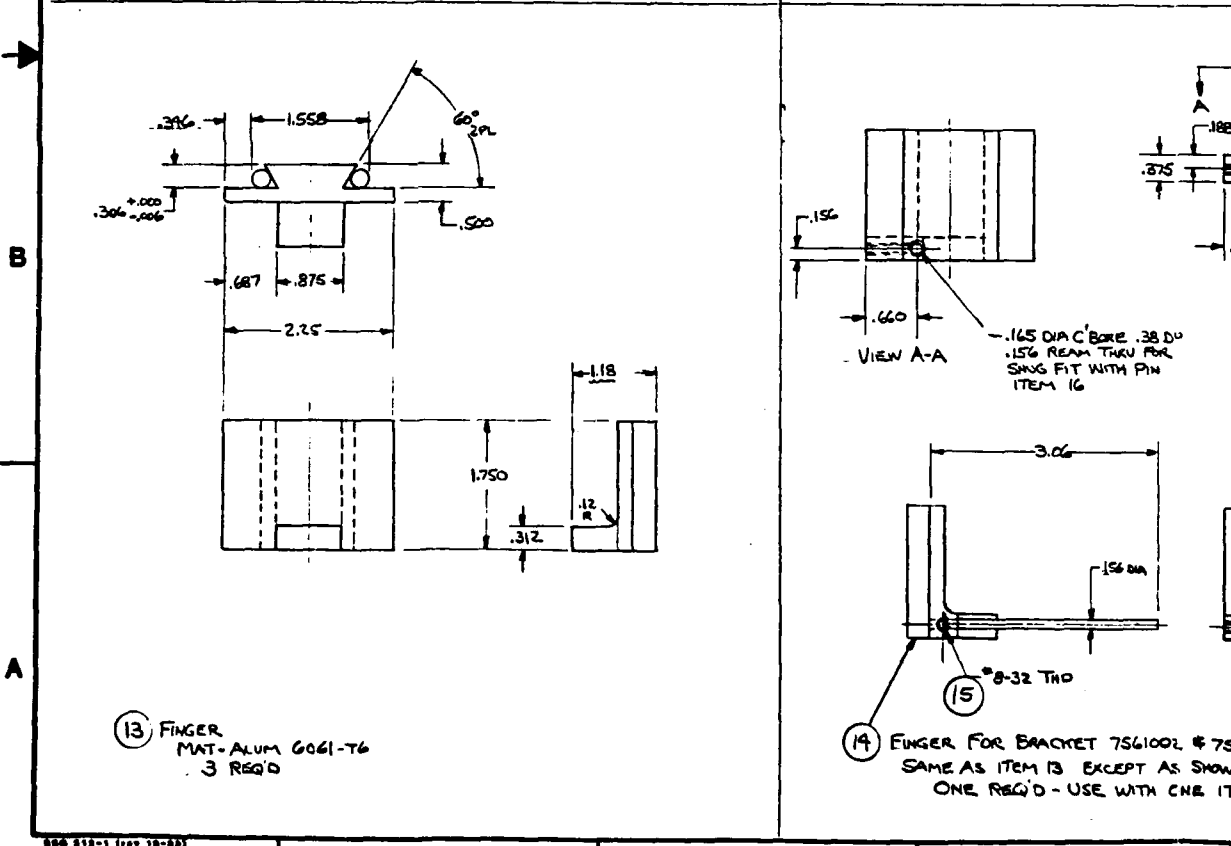
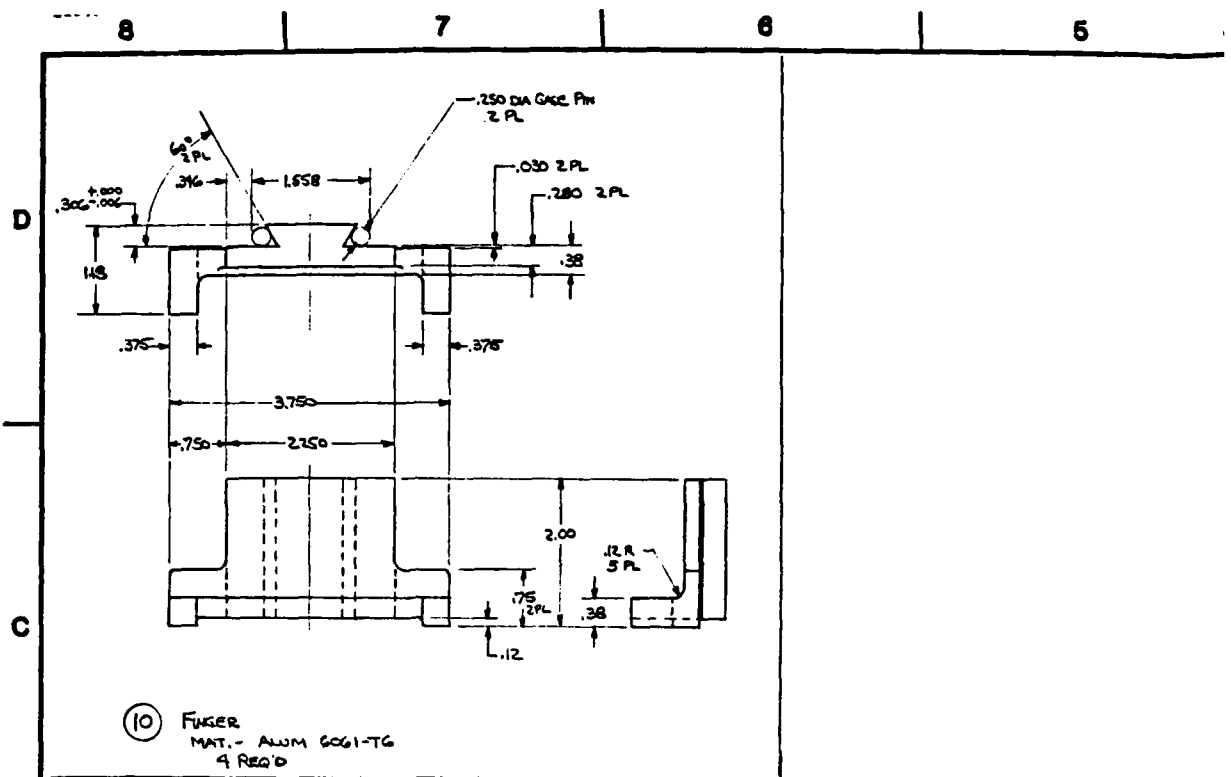

800 810-1 (REV 10-88)

REVISIONS					
ZONE	REV	DESCRIPTION	AUTH	DATE	APPROVED

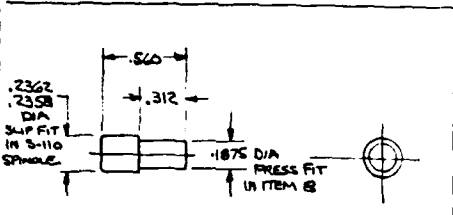
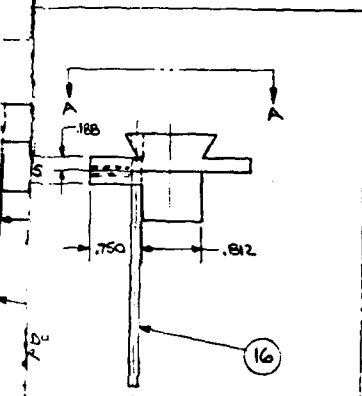

⑪ STEPPED DOWEL
MAY- DRILL ROD
ONE REQ'D.

Q1. # 756708A
AS SHOWN
ONE ITEM 13

THE PART NUMBER IS THE DRAWING NUMBER AND THE DASH NUMBER THAT APPLIES

UNLESS OTHERWISE SPECIFIED DIMENSIONS ARE IN INCHES	CONTR. OF A DIRECTOR	Delco Systems Operations GENERAL MOTORS CORPORATION OOLETA, CALIFORNIA	
TOLERANCES ON 2 PLACE DECIMALS 3 PLACE DECIMALS 3 ANGLES	ENGR	TITLE	
±.010 ±.005 ±1/2°	APVD	SIZE	REV
MATERIAL	APVD	D 13160	A
INTERPRET DRAWING PER DOD-STD-109	DO NOT SCALE DWG	FORM NO. 13160	DWG NO. SK005390
REF E-41	SCALE	SHEET 3 OF 4	

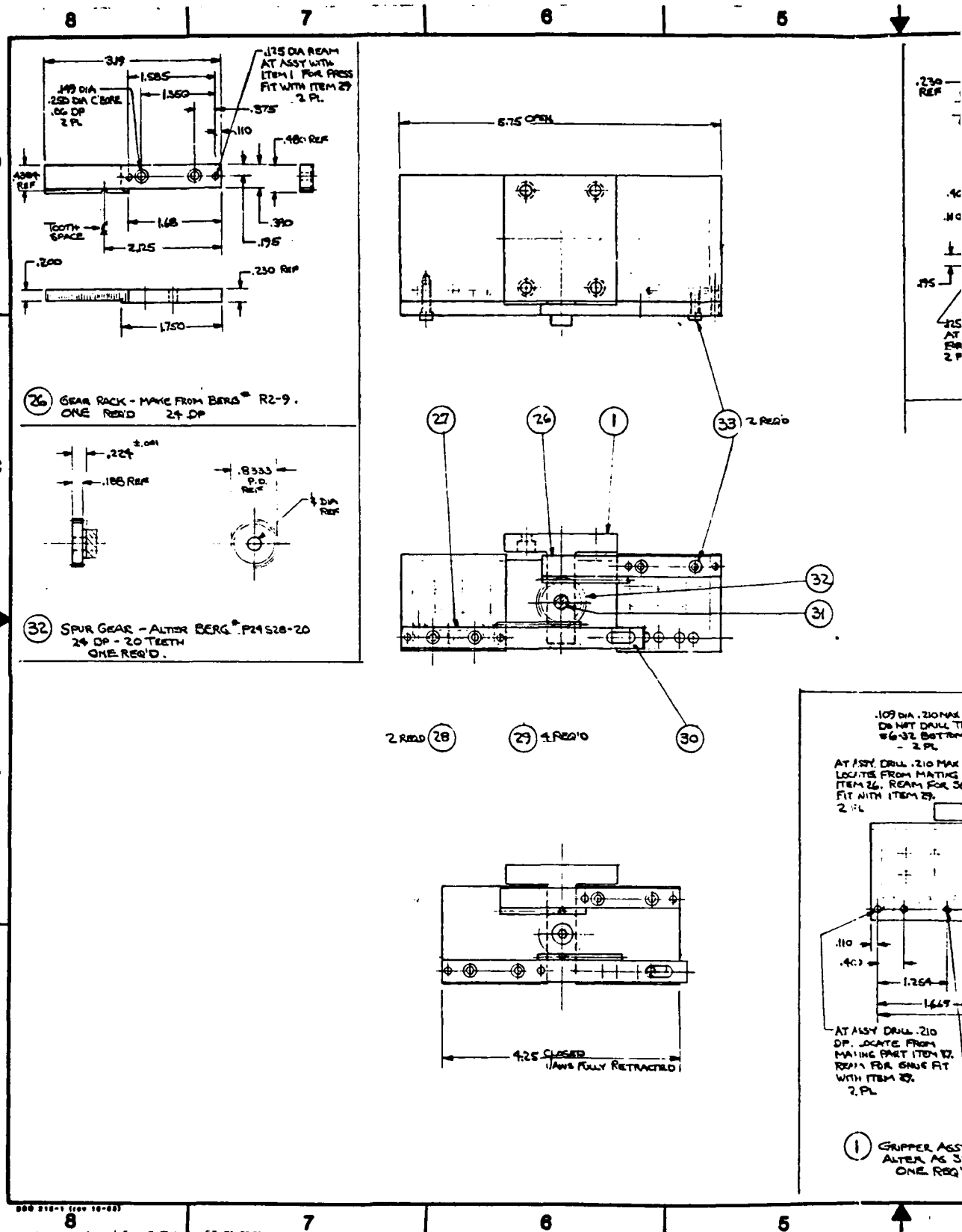

26 GEAR RACK - MAKE FROM BERG® R2-9.
ONE REQ'D 24 DP

32 SPUR GEAR - ALTER BERG® P24S28-20
24 DP - 20 TEETH
ONE REQ'D.

.109 DIA. .210 MAX
DO NOT DRILL TO
#6-32 BOTTOM
- 2 PL.

AT ASY. DRILL .210 MAX
LOCATE FROM MATING
ITEM 26. REAM FOR 3/4
FIT WITH ITEM 29.
2 PL.

AT ASY. DRILL .210
DP. LOCATE FROM
MATING PART ITEM 32.
REAM FOR GAUGE FIT
WITH ITEM 29.
2 PL.

1 GRIPPER ASS.
ALTER AS 3
ONE REQ'

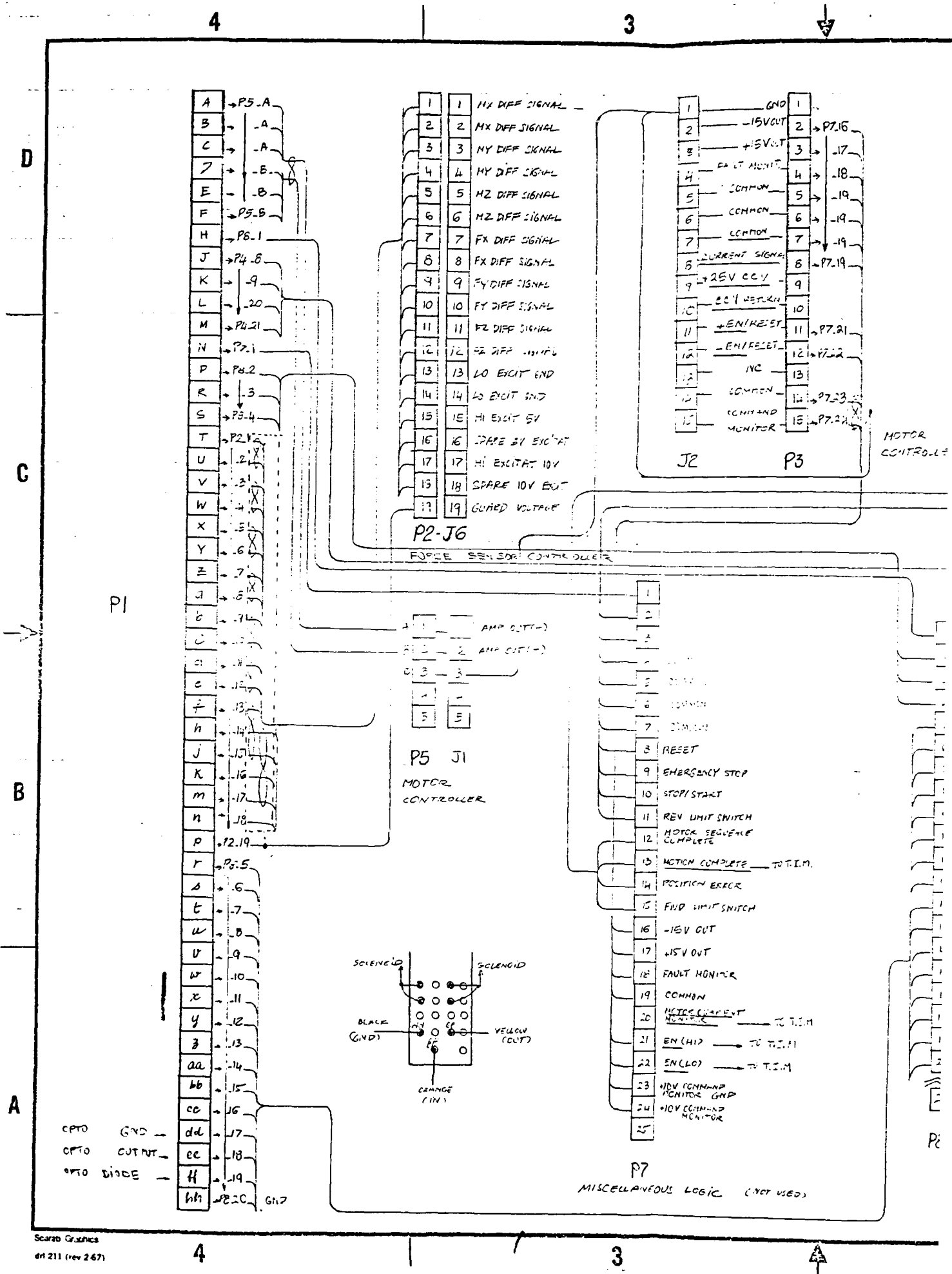

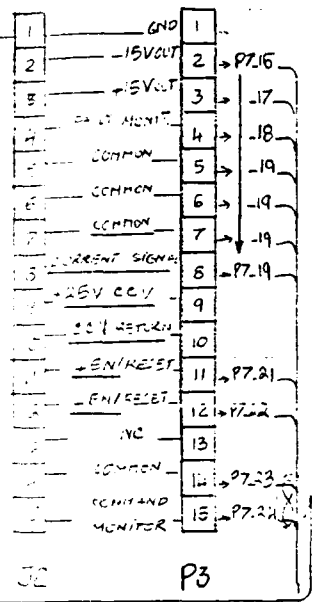

MOTOR CONTROLLER

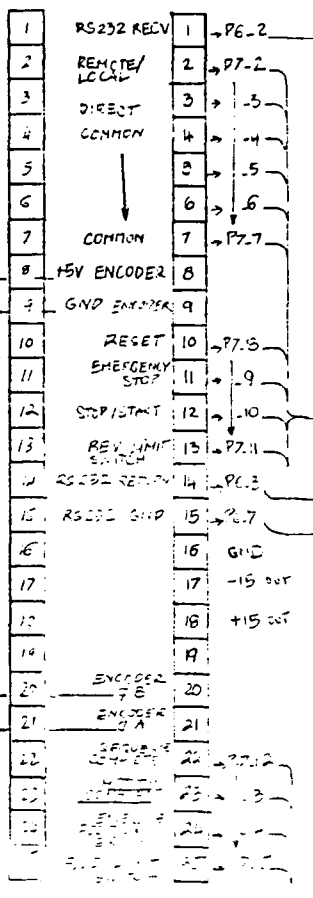

MOTOR CONTROLLER

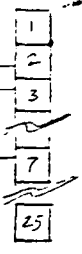

P6

RS-232C

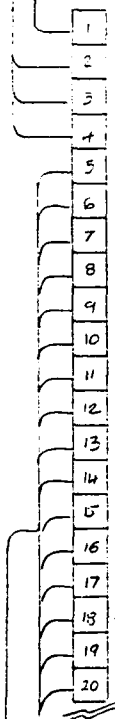

P8

- RESET
- EMERGENCY STOP
- STOP/START
- REV LIMIT SWITCH
- FAULT MONITOR
- ACTION COMPLETE TO T.I.M.
- POSITION ERROR
- FAULT MONITOR
- +15V OUT
- 15V OUT
- FAULT MONITOR
- COMMON
- MISCELLANEOUS TO T.I.M.
- EN (CH1) TO T.I.M.
- EN (LO) TO T.I.M.
- COMMAND MONITOR GND
- COMMAND MONITOR
- LOGIC (NOT USED)

REFERENCE ONLY

UNLESS OTHERWISE SPECIFIED DIMENSIONS ARE IN INCHES TOLERANCES ON 2 PLACE 3 PLACE ANGLES DECIMALS DECIMALS ± ± ±		CONTR. NO.		DATE		CHECKER		ENGR.		APPD.		APPD.		OSCN ACTIVITY APPD.		OTHER APPROVAL		SCALE		WEIGHT		SHEET / OF /	
		13160		12387		B																	

Radio Electronics
 GENERAL MOTORS CORPORATION SANTA BARBARA CALIF.
 TITLE: CABLE ASSY - T.I. - ED 5/12/86
 1/25/80

D
C
BWC 110
C-3

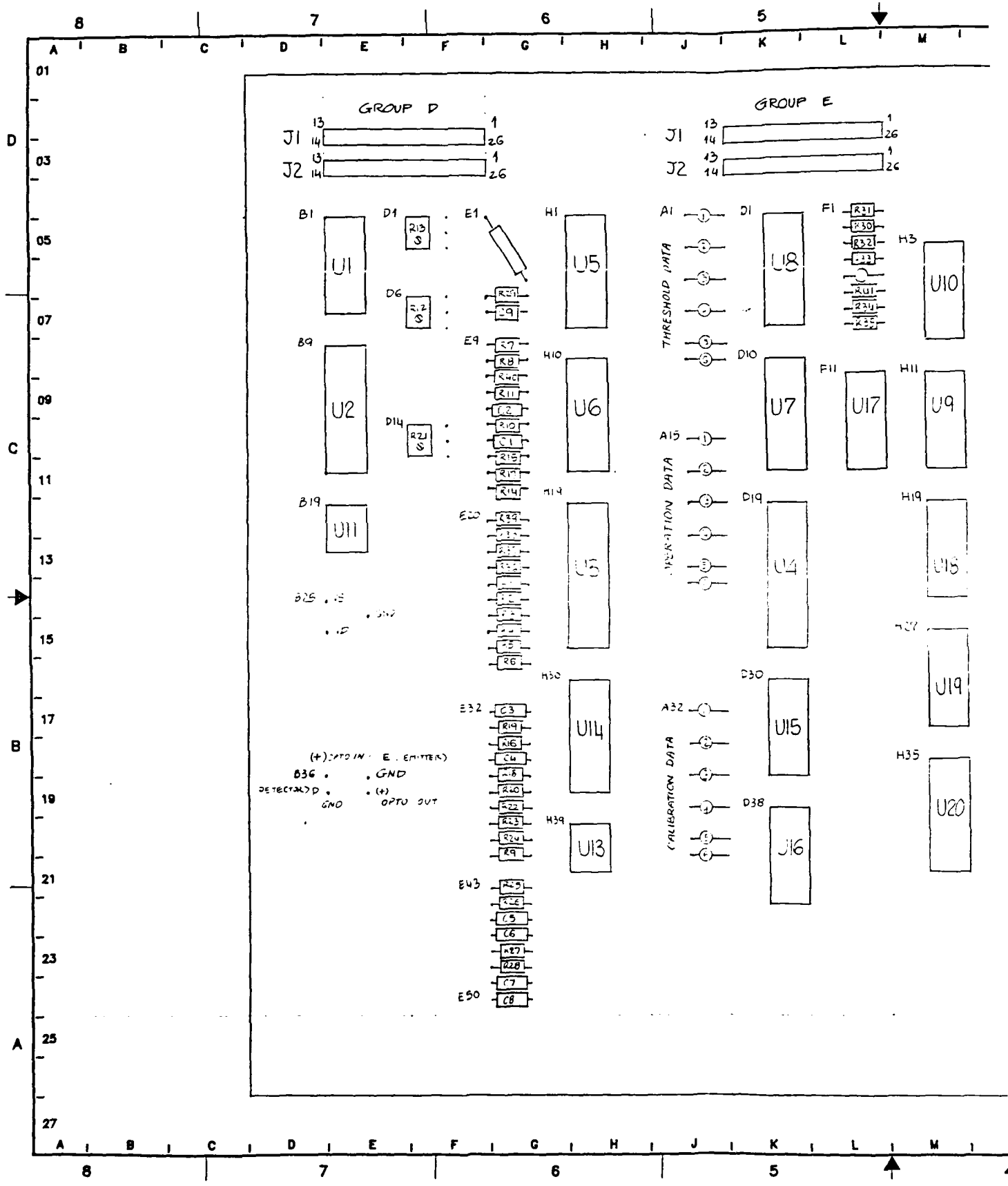

5

4

3

2

1

K | L | M | N | P | Q | R | S |

REVISIONS					
ZONE	REV	DESCRIPTION	AUTH	DATE	APPROVED
SEE SH1 FOR REV RECORD					
T	U	V	W	X	

GROUP E

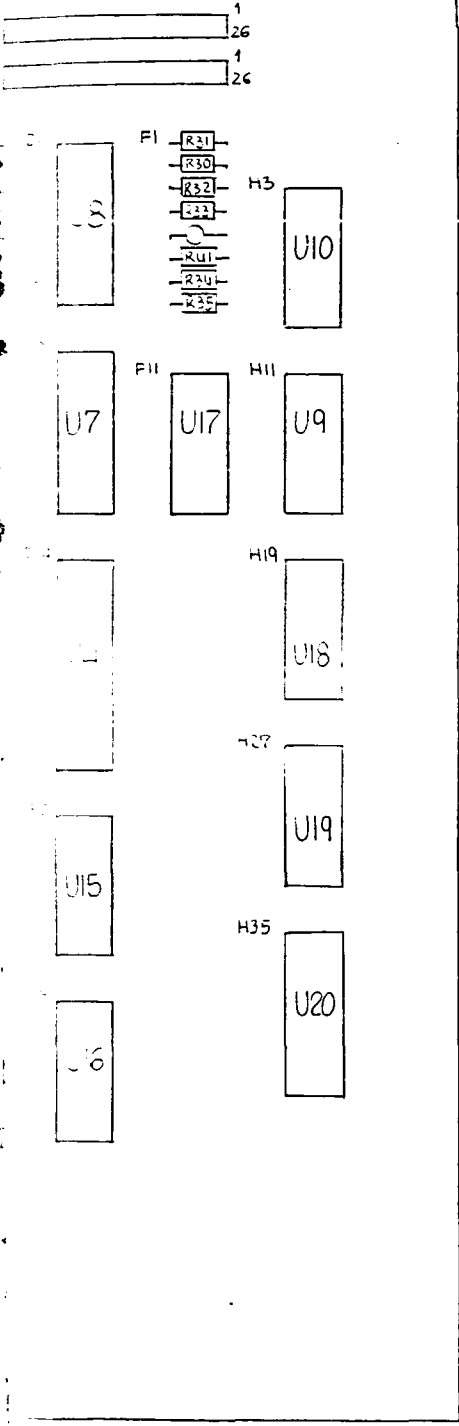

POWER SUPPLIES

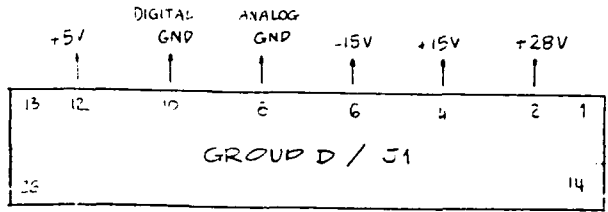

MOTOR CONTROLLER

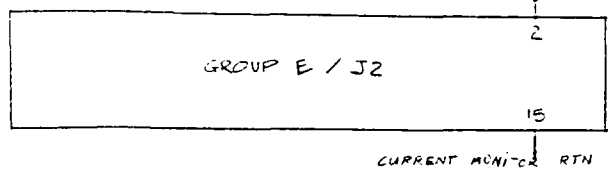

CARET CONTROL

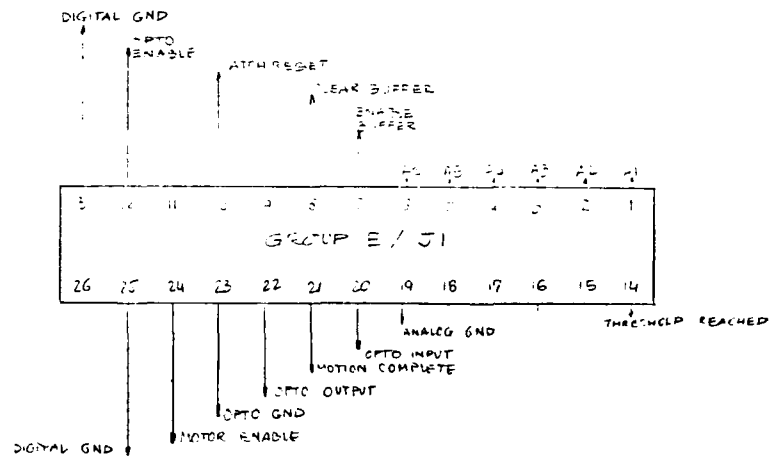

LEDS ON FRONT PANEL

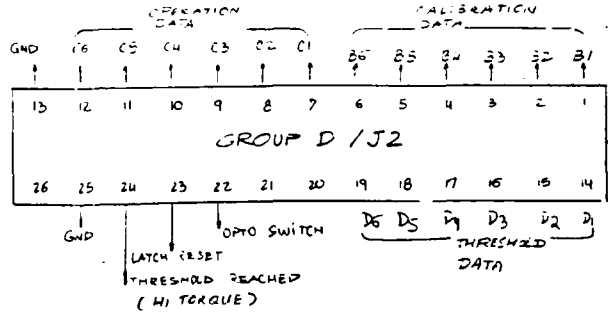

AUTOMATED THREAD INSPECTION CONTROL MODULE LAYOUT

DATE	PROJ. NO.	DRWG. NO.	REV.
D	13160	AT.I.C. LAY OUT	A

REFERENCE ONLY

K | L | M | N | P | Q | R | S | T |

5

4

3

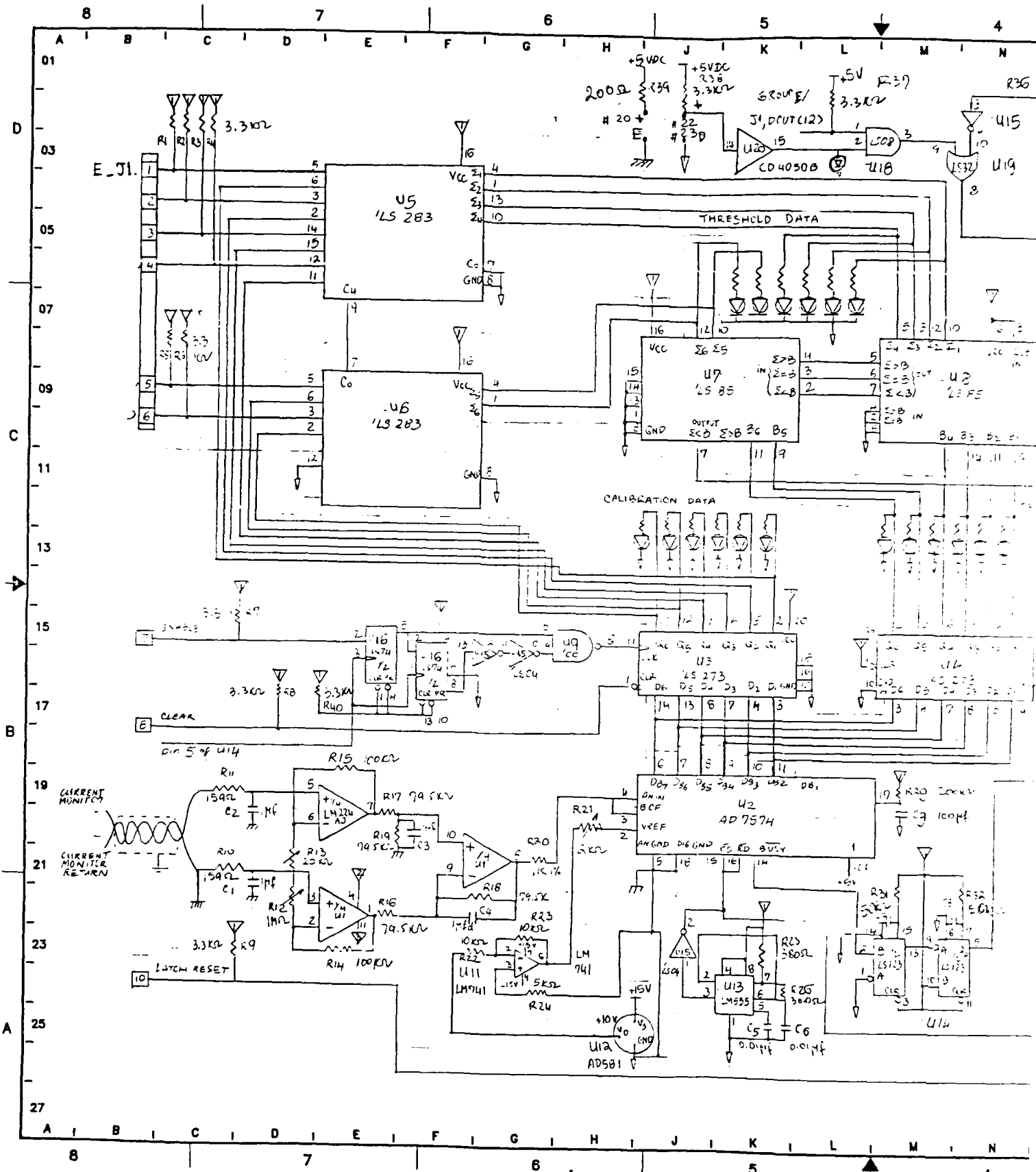

5 4 3 2 1

REVISIONS			
ZONE	REV	DESCRIPTION	APPROVED
SEE SH1 FOR REV RECORD			
T	I	U	V
W	X		

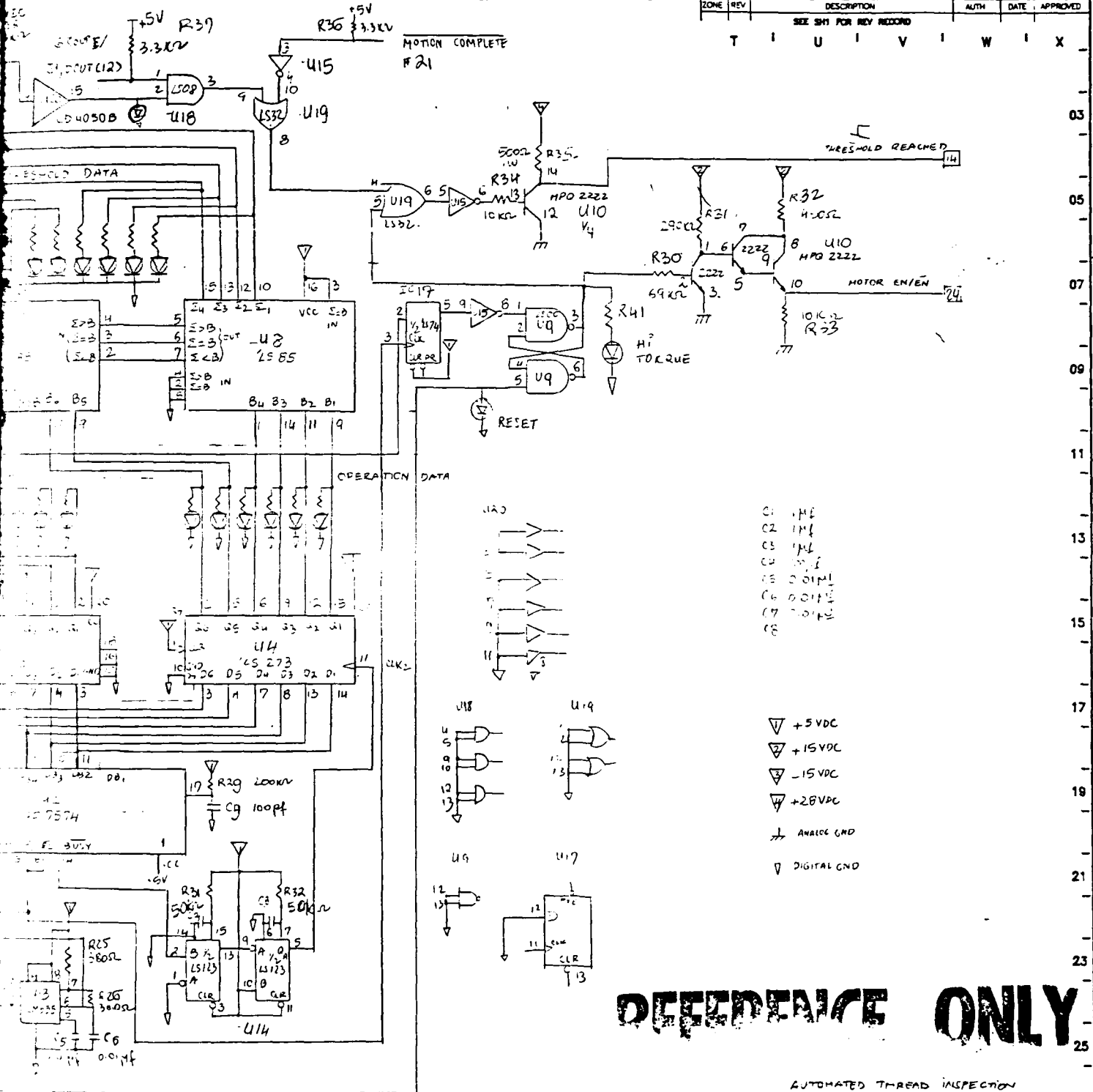

- C1 1M
- C2 1M
- C3 1M
- C4 100K
- C5 0.01M
- C6 0.01M
- C7 100K
- C8

- ▽ +5VDC
- ▽ +15VDC
- ▽ -15VDC
- ▽ +28VDC
- ⊕ ANALOG GND
- ▽ DIGITAL GND

DEFENDANCE ONLY

AUTOMATED THREAD INSPECTION
CONTROL MODULE CIRCUITRY

SIZE	FIG. NO.	DATE	REV.
D	13160	11 13 86	
SCALE			SHEET (OF)

5 4 3 2 1

1218861

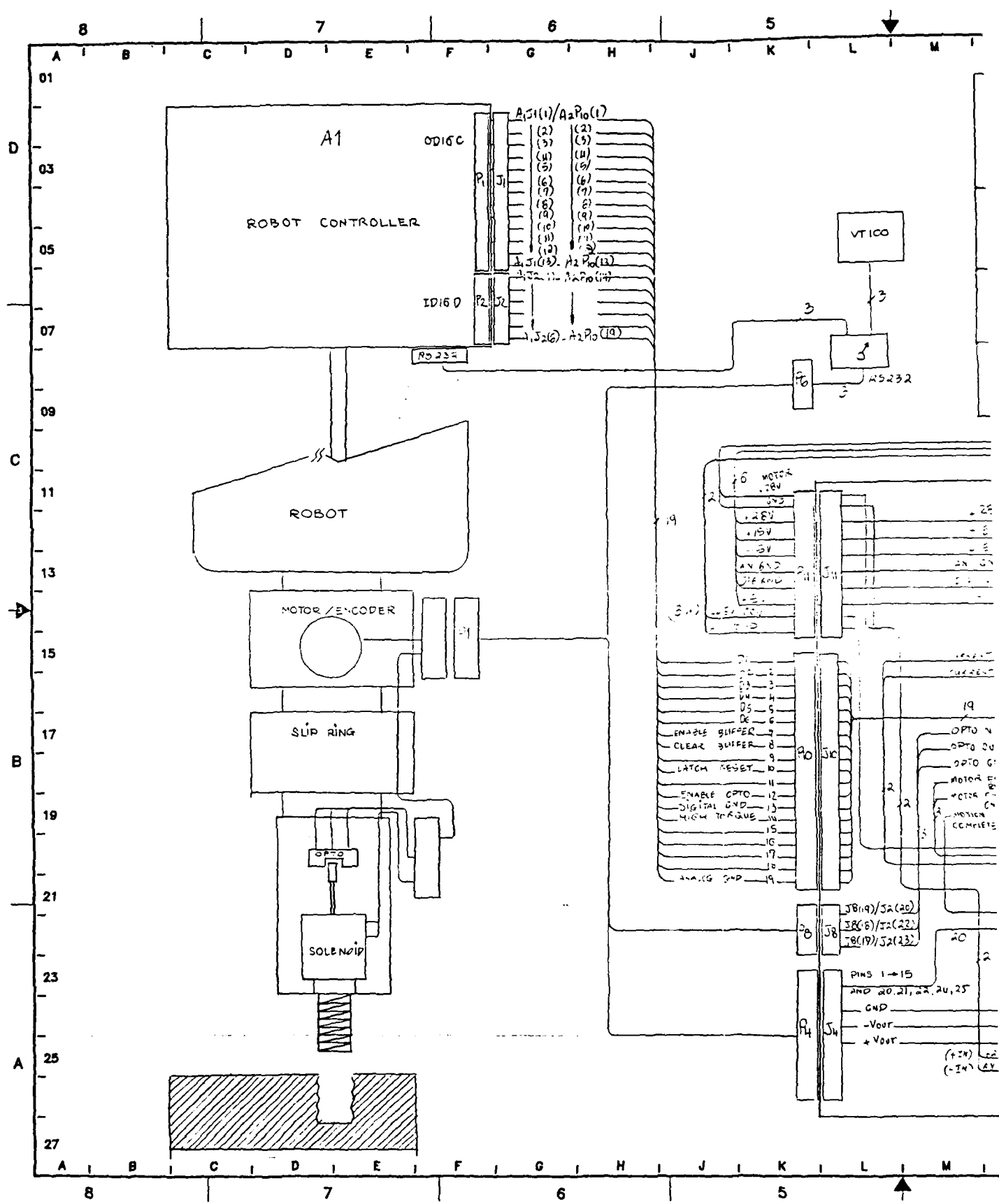

01
03
05
07
09
11
13
15
17
19
21
23
25
27

A B C D E F G H J K L M

8 7 6 5

A1
ODISC
ROBOT CONTROLLER
ID160
P1 J1
P2 J2
A1 J1(1)/A2 P10(1)
(2)
(3)
(4)
(5)
(6)
(7)
(8)
(9)
(10)
(11)
(12)
A1 J1(13)/A2 P10(13)
A1 J1(14)/A2 P10(14)
A1 J1(15)/A2 P10(15)
A1 J1(16)/A2 P10(16)
A1 J1(17)/A2 P10(17)
A1 J1(18)/A2 P10(18)
A1 J1(19)/A2 P10(19)
A1 J1(20)/A2 P10(20)
A1 J1(21)/A2 P10(21)
A1 J1(22)/A2 P10(22)
A1 J1(23)/A2 P10(23)
A1 J1(24)/A2 P10(24)
A1 J1(25)/A2 P10(25)
A1 J1(26)/A2 P10(26)
A1 J1(27)/A2 P10(27)
A1 J1(28)/A2 P10(28)
A1 J1(29)/A2 P10(29)
A1 J1(30)/A2 P10(30)
A1 J1(31)/A2 P10(31)
A1 J1(32)/A2 P10(32)
A1 J1(33)/A2 P10(33)
A1 J1(34)/A2 P10(34)
A1 J1(35)/A2 P10(35)
A1 J1(36)/A2 P10(36)
A1 J1(37)/A2 P10(37)
A1 J1(38)/A2 P10(38)
A1 J1(39)/A2 P10(39)
A1 J1(40)/A2 P10(40)
A1 J1(41)/A2 P10(41)
A1 J1(42)/A2 P10(42)
A1 J1(43)/A2 P10(43)
A1 J1(44)/A2 P10(44)
A1 J1(45)/A2 P10(45)
A1 J1(46)/A2 P10(46)
A1 J1(47)/A2 P10(47)
A1 J1(48)/A2 P10(48)
A1 J1(49)/A2 P10(49)
A1 J1(50)/A2 P10(50)
A1 J1(51)/A2 P10(51)
A1 J1(52)/A2 P10(52)
A1 J1(53)/A2 P10(53)
A1 J1(54)/A2 P10(54)
A1 J1(55)/A2 P10(55)
A1 J1(56)/A2 P10(56)
A1 J1(57)/A2 P10(57)
A1 J1(58)/A2 P10(58)
A1 J1(59)/A2 P10(59)
A1 J1(60)/A2 P10(60)
A1 J1(61)/A2 P10(61)
A1 J1(62)/A2 P10(62)
A1 J1(63)/A2 P10(63)
A1 J1(64)/A2 P10(64)
A1 J1(65)/A2 P10(65)
A1 J1(66)/A2 P10(66)
A1 J1(67)/A2 P10(67)
A1 J1(68)/A2 P10(68)
A1 J1(69)/A2 P10(69)
A1 J1(70)/A2 P10(70)
A1 J1(71)/A2 P10(71)
A1 J1(72)/A2 P10(72)
A1 J1(73)/A2 P10(73)
A1 J1(74)/A2 P10(74)
A1 J1(75)/A2 P10(75)
A1 J1(76)/A2 P10(76)
A1 J1(77)/A2 P10(77)
A1 J1(78)/A2 P10(78)
A1 J1(79)/A2 P10(79)
A1 J1(80)/A2 P10(80)
A1 J1(81)/A2 P10(81)
A1 J1(82)/A2 P10(82)
A1 J1(83)/A2 P10(83)
A1 J1(84)/A2 P10(84)
A1 J1(85)/A2 P10(85)
A1 J1(86)/A2 P10(86)
A1 J1(87)/A2 P10(87)
A1 J1(88)/A2 P10(88)
A1 J1(89)/A2 P10(89)
A1 J1(90)/A2 P10(90)
A1 J1(91)/A2 P10(91)
A1 J1(92)/A2 P10(92)
A1 J1(93)/A2 P10(93)
A1 J1(94)/A2 P10(94)
A1 J1(95)/A2 P10(95)
A1 J1(96)/A2 P10(96)
A1 J1(97)/A2 P10(97)
A1 J1(98)/A2 P10(98)
A1 J1(99)/A2 P10(99)
A1 J1(100)/A2 P10(100)

VT100
MS232
10 MOTOR 120V
+28V
+15V
-5V
+V 6V
+V AND
-V
-V
ENABLE BUFFER
CLEAR BUFFER
LATCH RESET
ENABLE OPTO
DIGITAL GND
HIGH TORQUE
ANALG GND
PINS 1-15
AND 20, 21, 22, 24, 25
GND
-V00T
+V00T
(+IN) GND
(-IN) GND

5 4 3 2 1

K L M N P Q R S T U V W X

REV. NO.		DESCRIPTION	AUTH	DATE	APPROVED
1		SEE SH1 FOR REV RECORD			

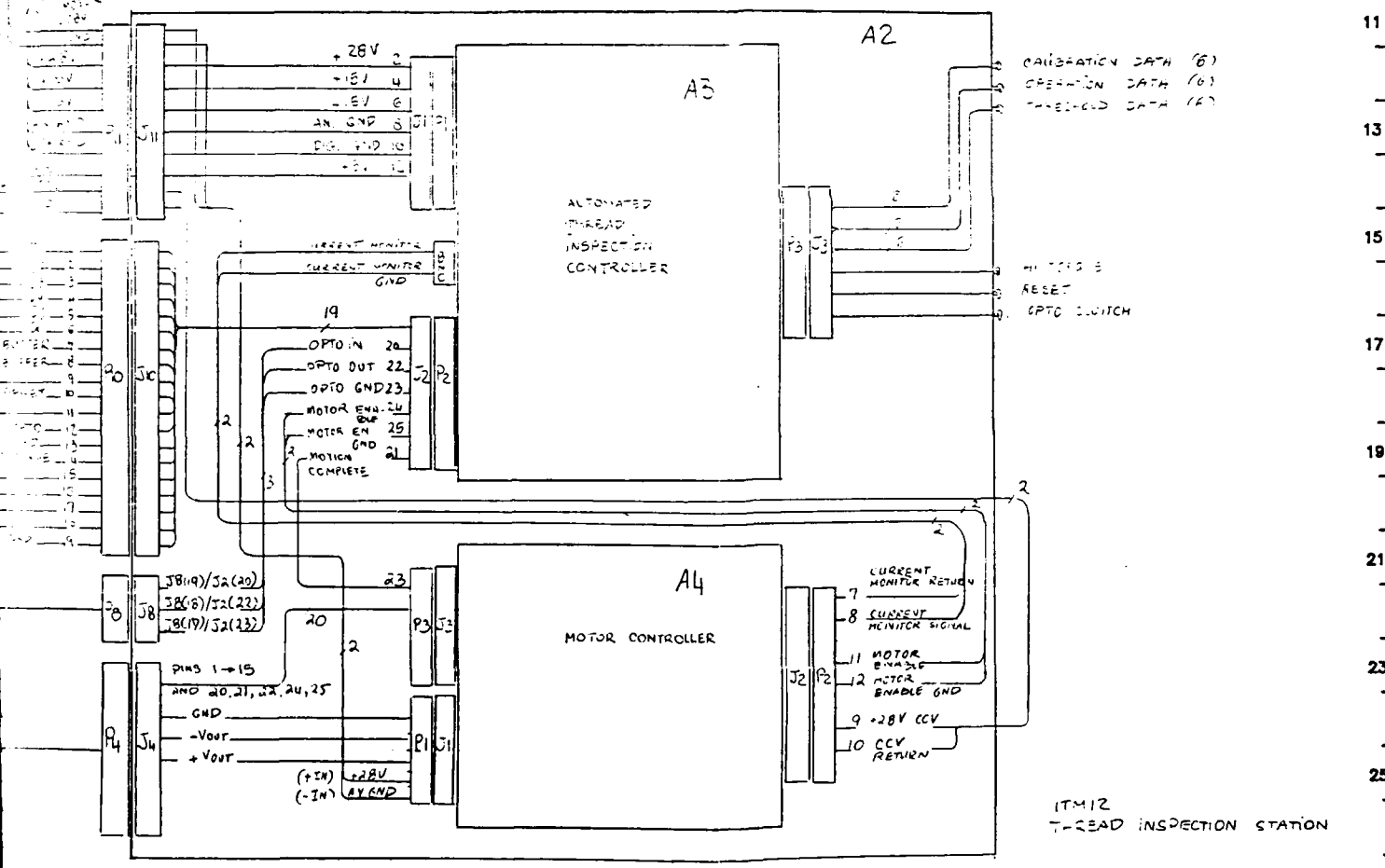
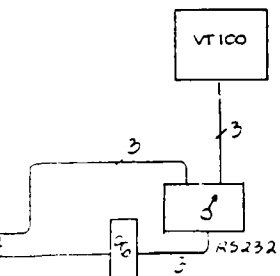
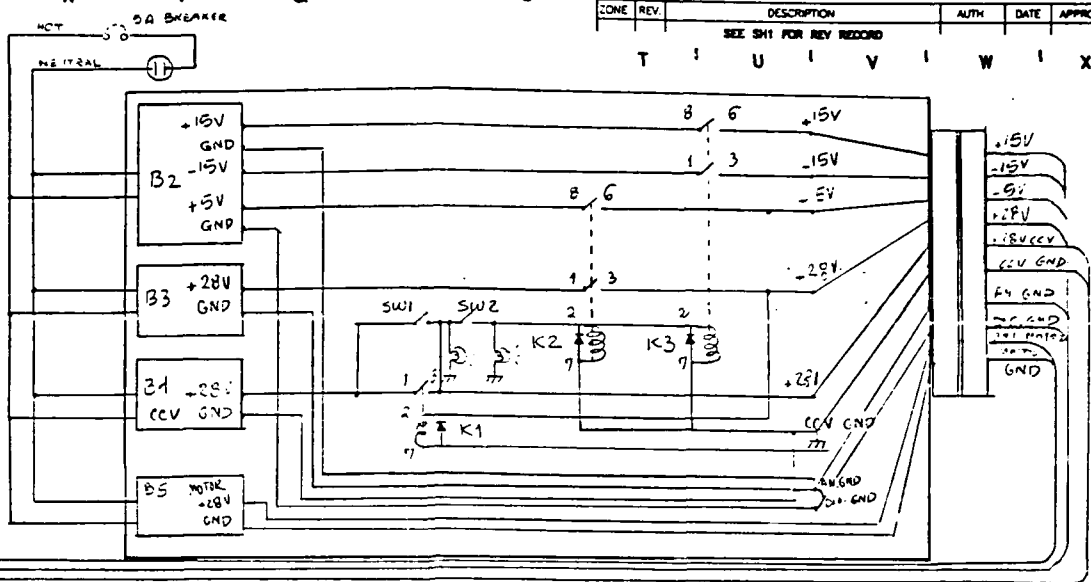

SIZE	PROJ NO.	DWG NO.	DATE	REV.
D	13160		1/6/1987	

REFERENCE ONLY

1. BREAK ALL SHARP CORNERS .005-.015 RND OR CHAM.

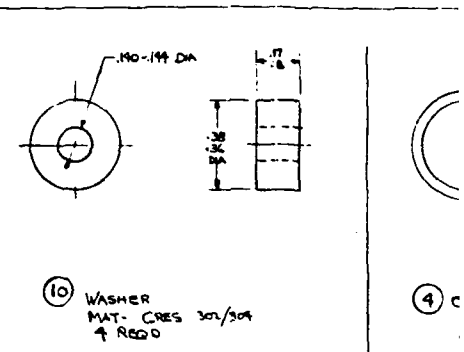
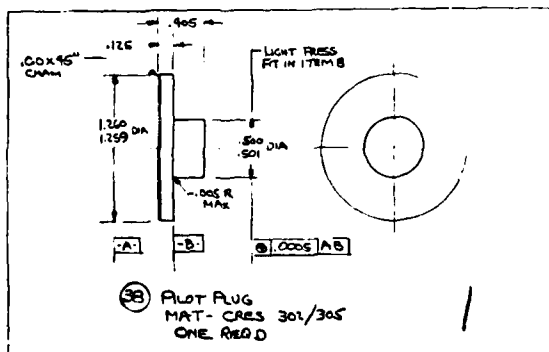
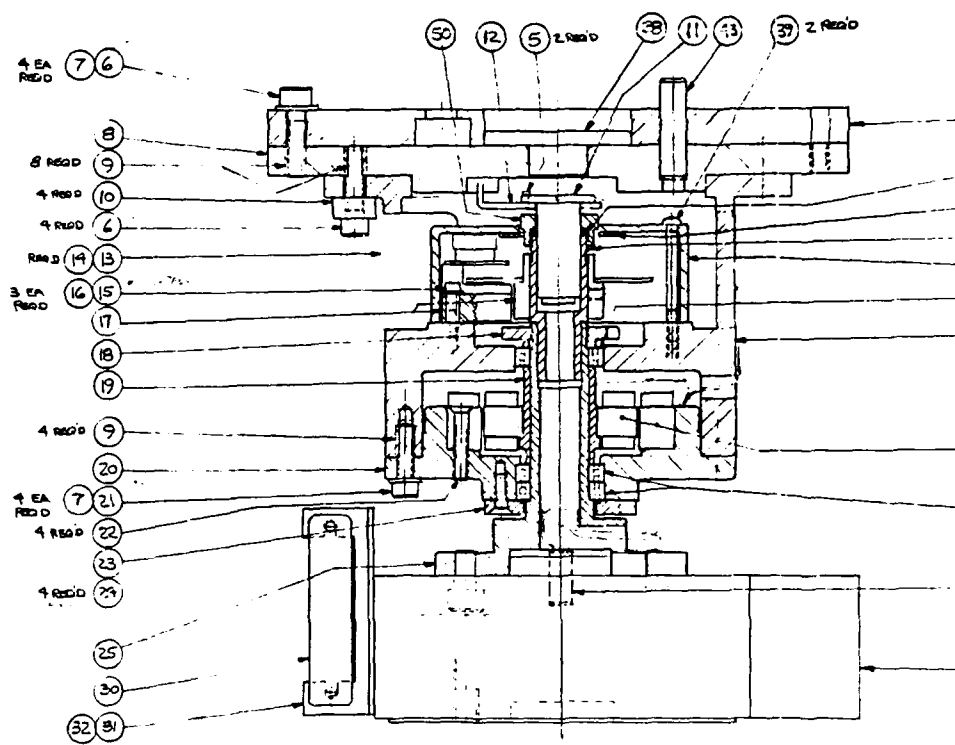
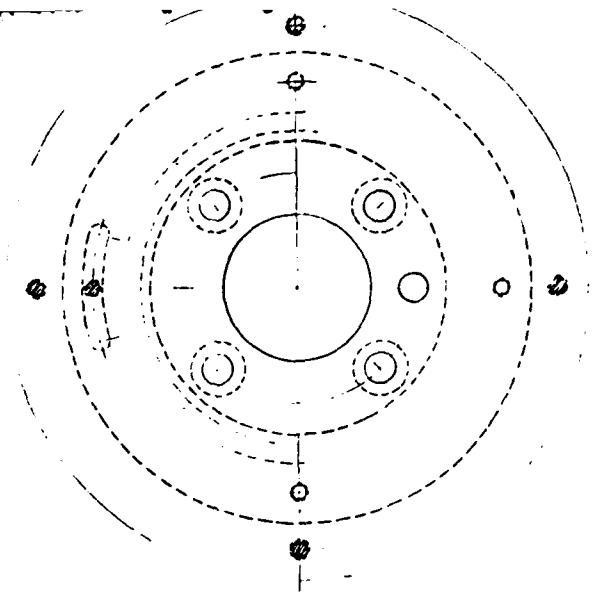

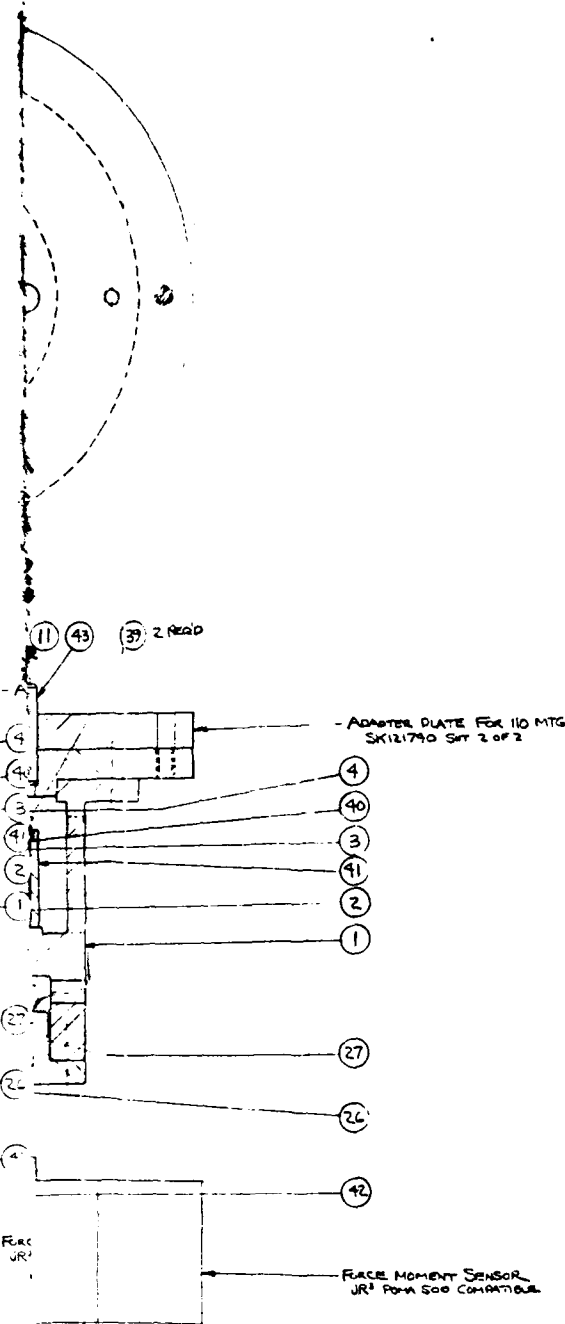

QTY	ITEM	DESCRIPTION	DATE	APPROVED
	A	ADAPTER SHEET 4 (POMA) WITH 10 MTG 44 THRU 48	11/17/86	SKT

50		-SEE SHEET 4 (D BIER)		
49				
48				
47				
46				
45				
44		-SEE SHEET 4 (D BIER)		
43	1	DOWEL 6 MM (.1562) DIA X 3/8 LG		STEEL
42	1	DOWEL 3/8 DIA X 1/2 LG		STEEL
41	1	COVER, ENCODER		ALUM 6061-T6
40	1	FELT SEAL		ALUM 6061-T6
39	2	#2-56 X 1/8 LG PAN HD SCR		ALUM 6061-T6
38	1	PISTON RING 1 3/8 OD X 1" LG		CRS
37	1	COVER .040 THICK X 1 1/2 X 6" LG		ALUM 6061-T6
36	1	BRACKET .050 THICK X 1 X 2		ALUM 6061-T6
35	10	#4-40 X 1/4 LG FIN HD SCR		MS 6795-13
34	1	COVER .040 THICK X 1 1/2 X 6" LG		ALUM 6061-T6
33	2	#2-56 X 1/8 LG SK. HD SCR		MS 1695-2
32	1	BRACKET .050 THICK X 1/2 X 2		ALUM 6061-T6
31	1	BRACKET .050 THICK X 2 X 2		ALUM 6061-T6
30	2	CONNECTOR SERCOS-49J WITH PIN		
29	2	#2-56 HEX NUT		
28	2	#2-56 X 1/8 LG PAN HD SCR		MS 1957-2
27	1	DC TORQUE MOTOR #D-1938-A-2		PUMA
26	1 PMA	MFD DUPLX BRG # SB12MC		
25	1	SPINDLE 2 1/4 DIA X 2 1/2 LG		STEEL 4130
24	4	#4-40 X 3/8 LG 100° CSK HD SCREW		MS 21092-002
23	1	CLAMP RING 1 1/2 DIA X 3/8 THICK		ALUM 6061-T6
22	4	#2-56 X 3/8 LG 82° CSK HD SCREW		MS 1957-8
21	4	#6-32 X 1/2 LG SK. HD SCR		MS 1695-18
20	1	BEARING PLATE 2 1/4 DIA X 1" THICK		ALUM 6061-T6
19	1	SPACER SUBSEAL 3/4 DIA X 2" LG		STEEL 1070
18	1	NUT-SHIRT 1" DIA X 1" LG		STEEL 1020
17	1	ENCODER		PUMM - RENDCO
16	3	#2 FLAT WASHER		
15	3	#2-56 X 3/8 LG SK. HD SCR (OUT OF ALUM SCR)		MS 1675-4
14				
13	1	SHIELD		
12	1	RESTRAINT .050 THICK X 3/4 X 2		ALUM 6061-T6
11	1	SLIP RING CAPSULE ASST DRNG # 9791C		PUMM
10	4	SPACER WASHER 3/8 DIA X 1/4 LG		CRS 302/304
9	12	#6-32 X 1 1/2 DIA LG MECHNL INSERT - SELF LOCK		
8	1	TOP PLATE 1/2 THICK X 5 1/4 DIA		ALUM 6061-T6
7	8	#6 FLAT WASHER		CRS
6	8	#6-32 X 3/8 LG SKR. HD SCR		MS 1695-19
5	2	#60 USM (.0234 DIA) X 1/8 LG B. JMG HD BEAR		MULTI-TAG-60UM
4	1	O-RING 3/4 DIA X .070 THICK # 2018		NEOPRENE
3	1	EXTENSION-SPINDLE 5/8 DIA X 2" LG		ALUM 6061-T6
2	1	BALL BEARING MFD SB12MC		
1	1	HOUSING 4 1/4 DIA X 2 3/4 LG		ALUM 6061-T6

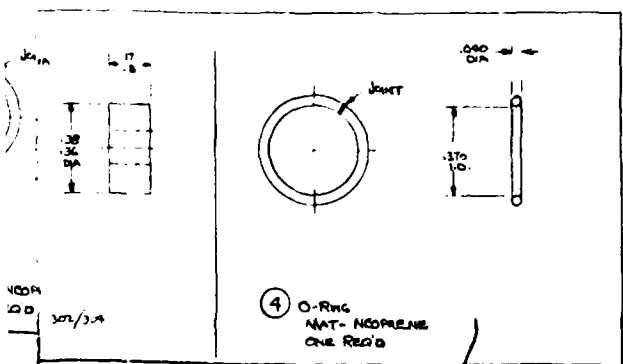

ITEM	QTY	DESCRIPTION	MATERIAL
PARTS LIST			
UNLESS OTHERWISE SPECIFIED DIMENSIONS ARE IN INCHES TOLERANCES ARE FRACTIONS DECIMALS ANGLES IN DEGREES SEE #			
CONTRACT NO. W.A. 460102		DATE	
DESIGNED BY A. ORSCHLER		CHECKED	
DRIVE MOTOR ASSY - THREAD INSPECTION ITEM PROJECT 12 PROJECT Q002 E41			
REV	DESCRIPTION	DATE	BY
E	17/60	SK005340	A
NEXT ASSY		USED ON	APPLICATION
DO NOT SCALE DRAWING			

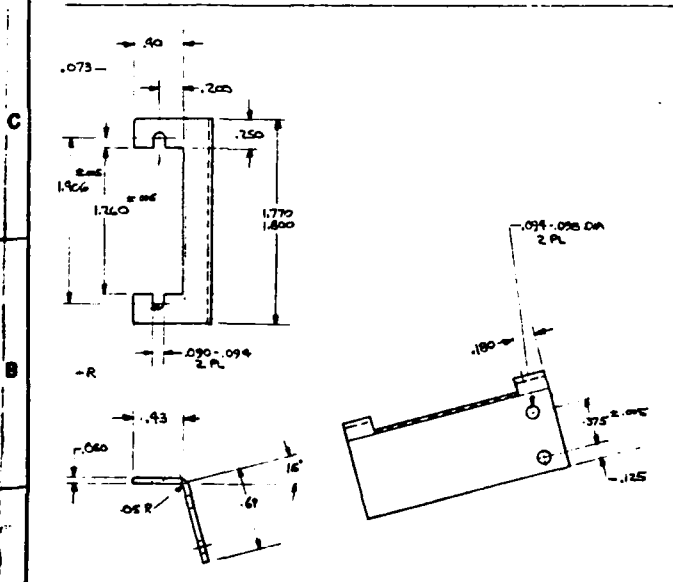
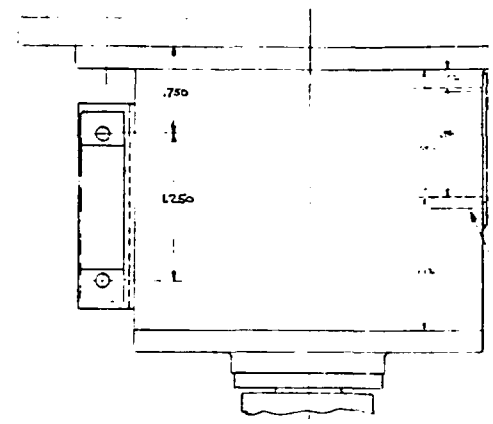
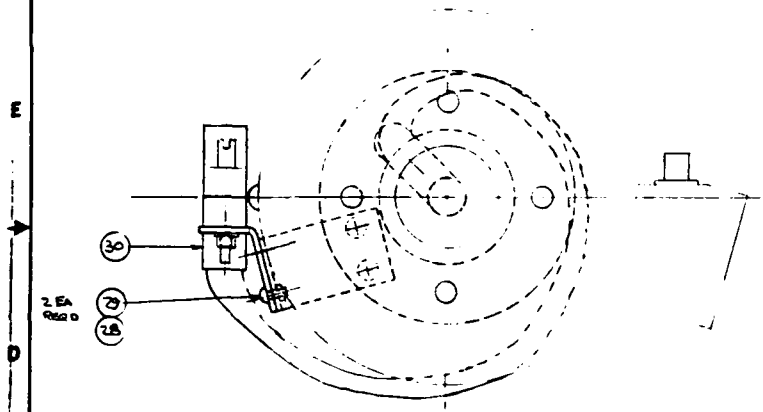
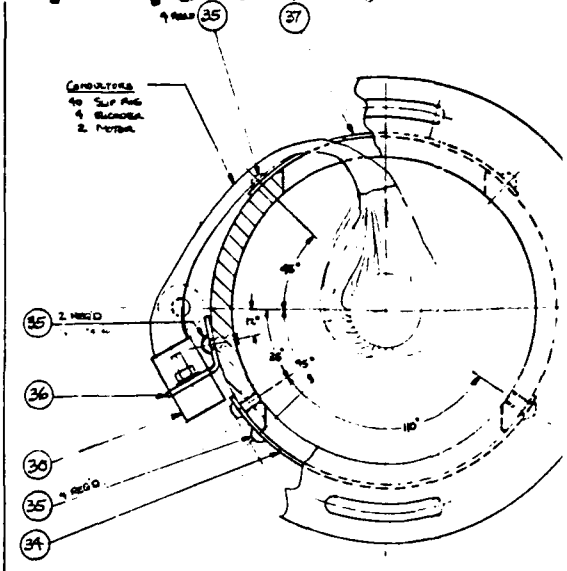
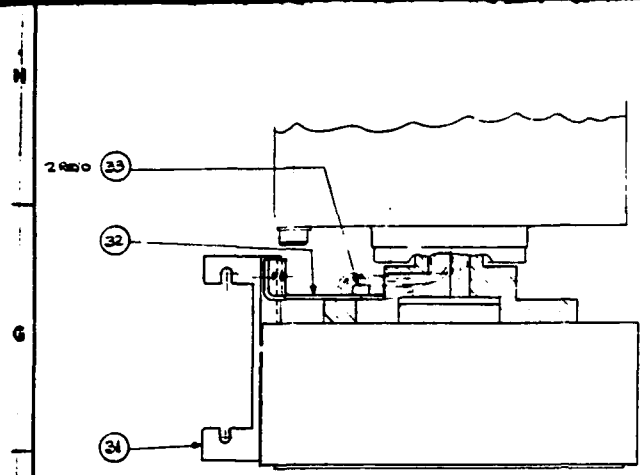

31 BRACKET
MAT: 6061-T6 ALUM
ONE REQ'D.

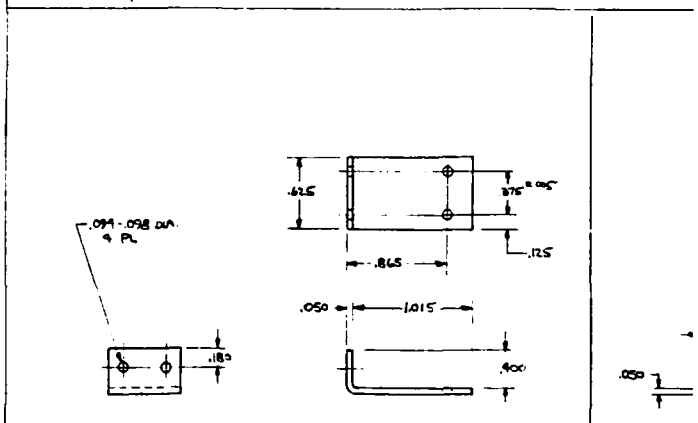

32 BRACKET
MAT: 6061-T6 ALUM
ONE REQ'D.

SAM
36

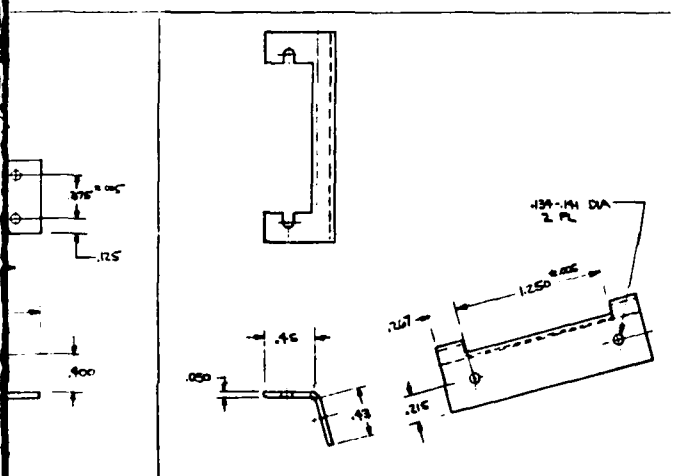
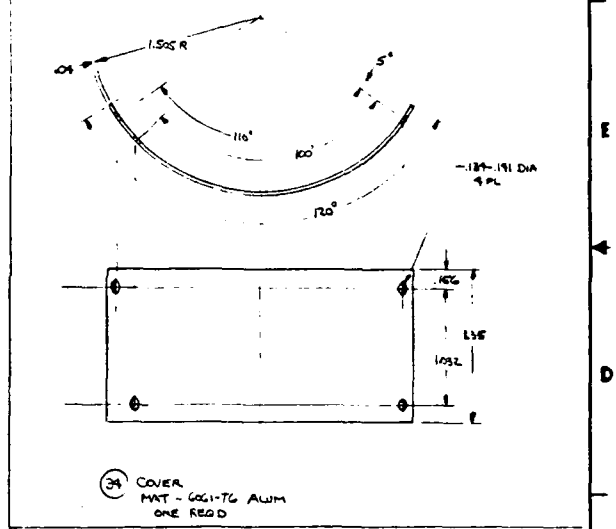
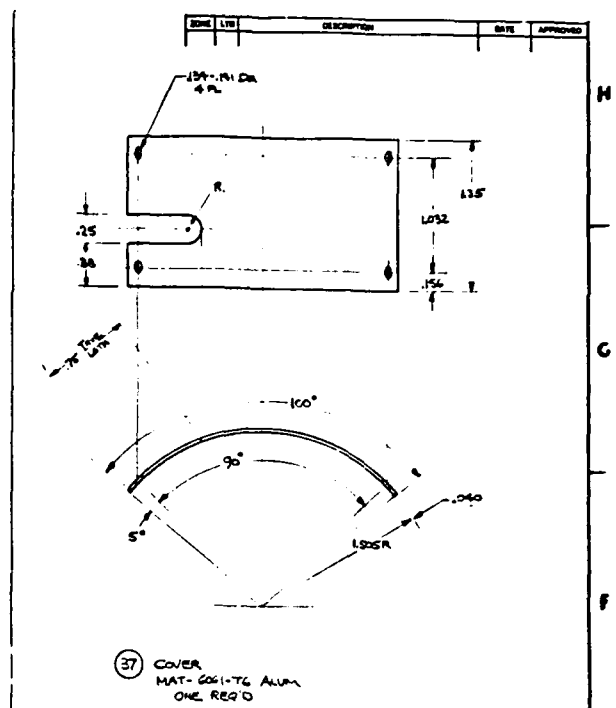
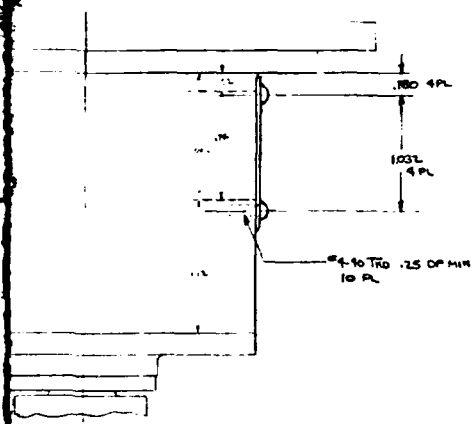
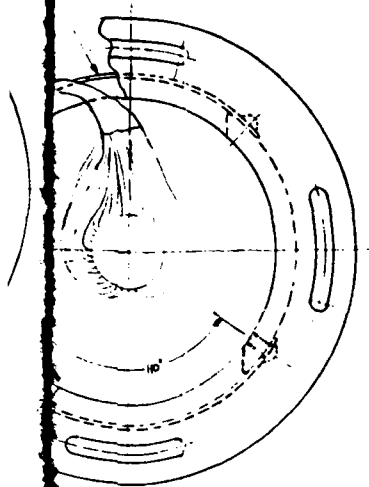

NOTE: TOLERANCES ON SHEET METAL PARTS UNLESS OTHERWISE SPECIFIED
 .XXX 2.015
 .XXX 2.010

QTY		CODE	PART OR IDENTIFYING NO.	NUMERICAL OR DESCRIPTION
PARTS LIST				
UNLESS OTHERWISE SPECIFIED DIMENSIONS ARE IN INCHES TOLERANCES ARE:		CONTRACT NO.	DATE	
FRACTIONS DECIMALS ANGLES		W.A. 460102	07/04/65	
° ' " ° ' " ° ' "		APPROVALS	DRAWN MOTOR ASSY - TRAINING INSPECTION	
BY		DESIGN A. DUNBAR	PROJECT CODE E41	
CHK'D		CHK'D	SIZE CODE PART NO. DRAWING NO. PART	
SEE L/M			E 2 60 SK005390 A	
NEXT ASSY		USED ON	SCALE 2X 1/2" = 1" SHEET 3 OF 4	
APPLICATION		DO NOT SCALE DRAWING		

2

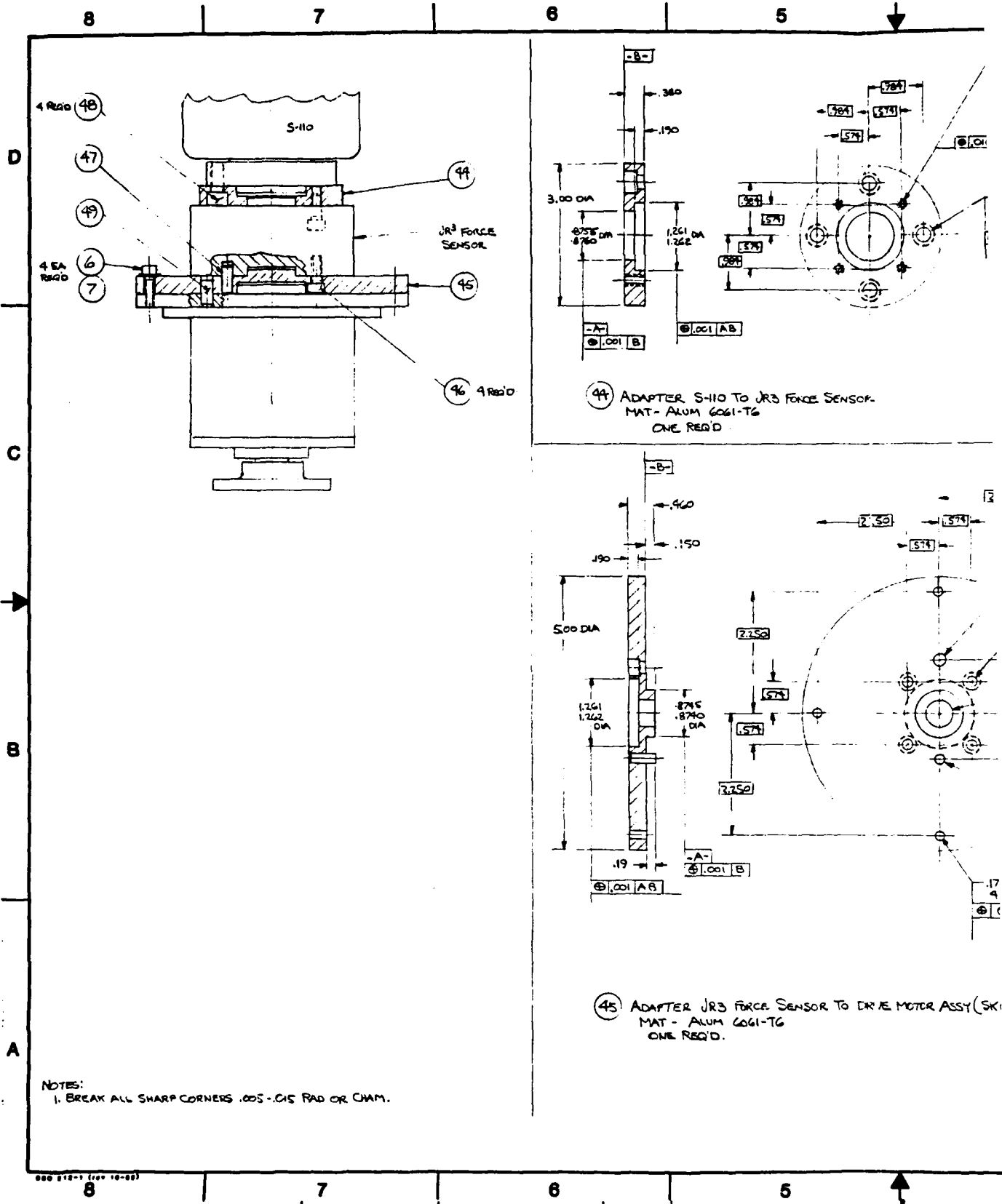

D
C
B
A

8 7 6 5

8 7 6 5

4

3

D

C

B

A

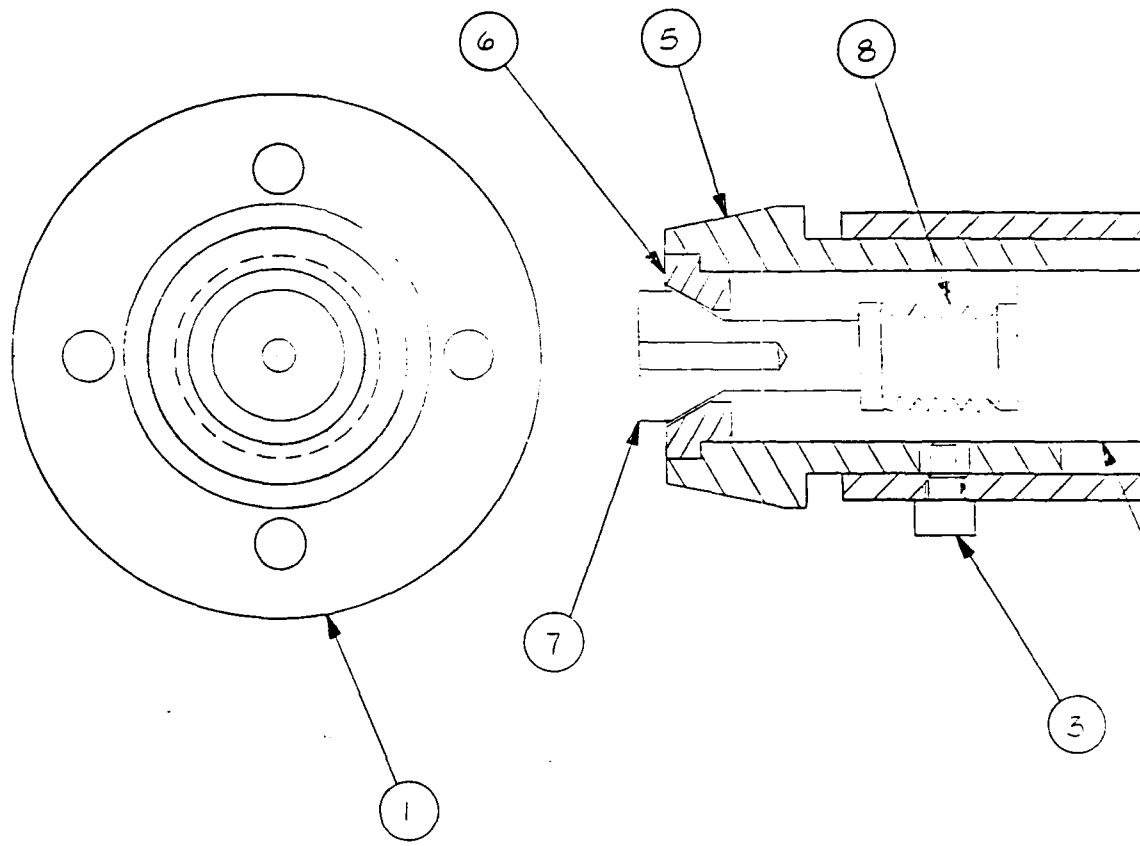

4

3



REVISIONS				
REV	DESCRIPTION	AUTH.	DATE	APPROVED

D

C

↑

51

DWG NO SK100474

A

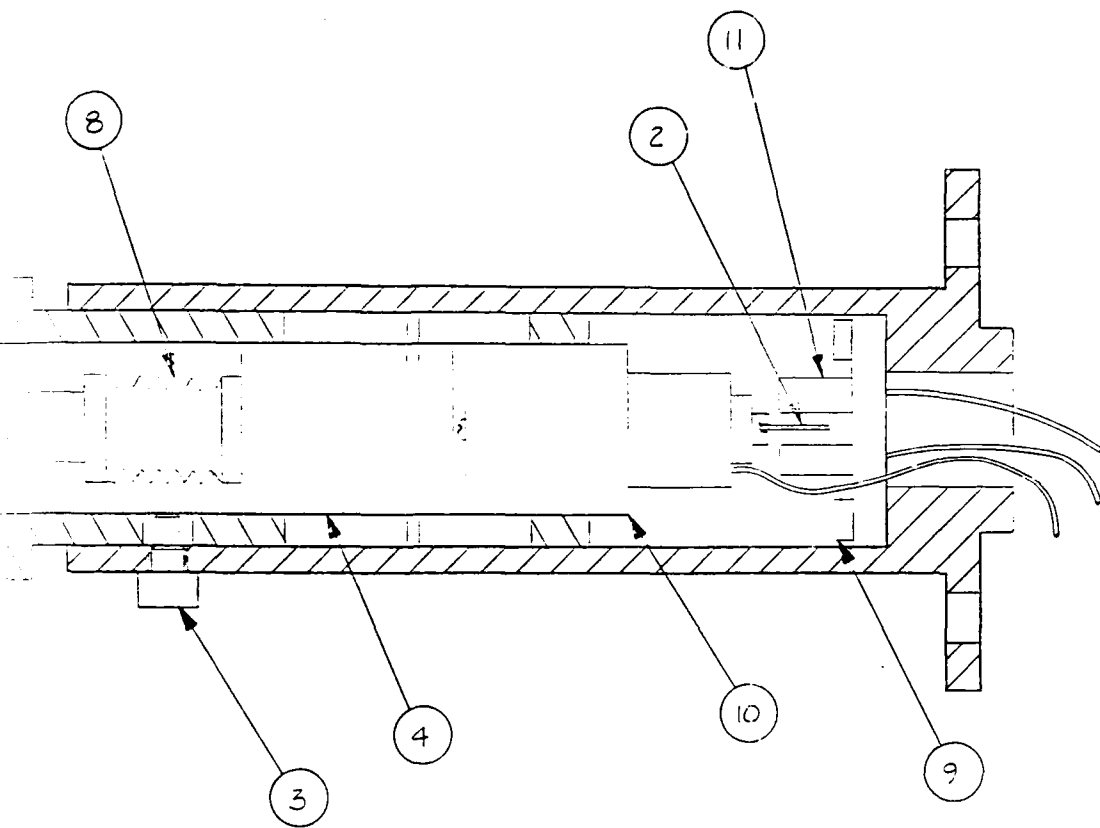

REFERENCE ONLY

SIZE	FSCM NO	DWG NO	REV
C	13160	SK100474	-
SCALE 2/1		SHEET 2	

↑

2

1

2

PARTS LIST		CONTRACT NO.		FSCM	REV LTR			
LIST TITLE		AUTHENTICATION		REVISION AUTH NO.	REV DATE			
EOAT ASSY		DRAWING OR DOCUMENT NUMBER		NOMENCLATURE OR DESCRIPTION	PL NOTES			
FIND NO.	QTY REQD	QTY REQD	QTY REQD	UNIT OF MEAS	FSCM	PART OR IDENTIFYING NUMBER	SHELL	PL NOTES
1						SK100473-001	SHELL	
2						SK100472-001	FLAG, INTERRUPT	
3						SK100471-001	SCREW, LOCKING	
4						SK100470-001	PISTON	
5						SK100468-001	SLIDER	
6						SK100467-001	MOUNT GAGE	
7						SK100466-001	NUT, END	
8						FC-9	BELLOWS (SERVOMETER)	
9				2			SCREW 4-40 X .25	
10				1		R12 X 6	SOLENOID (REGDON)	
11				1		TIL143	SENSOR (TI)	

REVISIONS					
ZONE	REV	DESCRIPTION	AUTH.	DATE	APPROVED

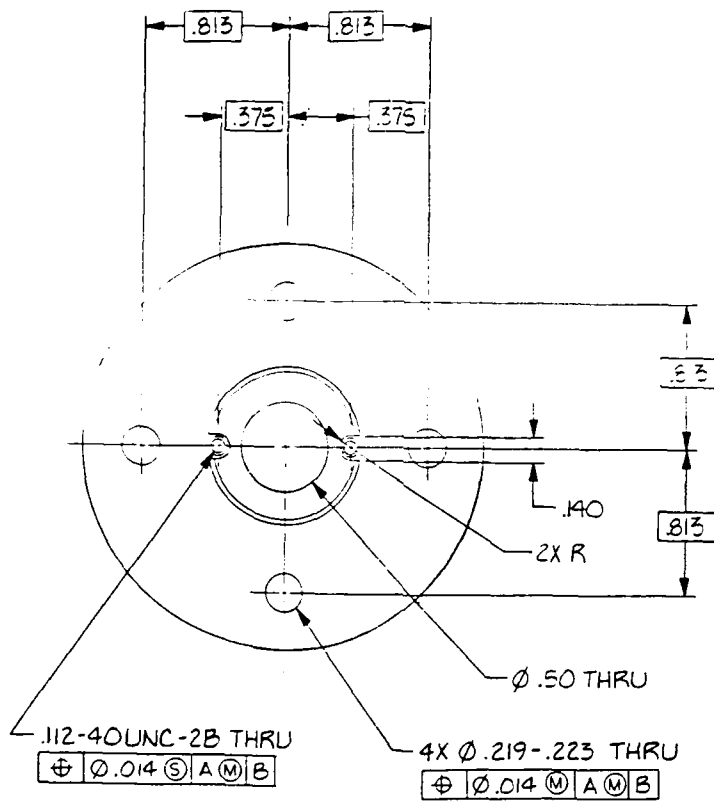

REFERENCE ONLY

UNLESS OTHERWISE SPECIFIED DIMENSIONS ARE IN INCHES						CONTR. NO. —		Delco Systems Operations	
TOLERANCES ON 2 PLACE DECIMALS ± .01						DFT S. Allen 87-4-28		GENERAL MOTORS CORPORATION GOLETA, CALIFORNIA	
3 PLACE DECIMALS ± .005						CHKR		TITLE	
ANGLES ± —						ENGR <i>Amund</i> 87-4-29		SHELL	
MATERIAL						APVD		SIZE	
AL ALLOY						APVD		FSCM NO.	
6061-TEMP T6						APVD		D 13160	
INTERPRET DRAWING PER DOD-STD-100						DSGN ACTIVITY APVD		DWG NO.	
DO NOT SCALE DWG						REF E41		SK100473	
						SCALE 2/1		REV. -	
								SHEET OF	

005 1

005 1

005 1

005 1

005 1

4

3

2

1

D

C

B

SH

DWG NO.

A

NOTES:

1. MAKE FROM MS16995-25.

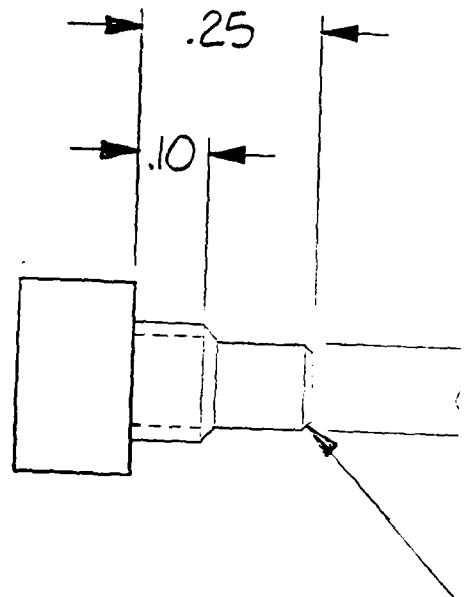

UNLES: DIMEN
2 PLAC DECIMAL ± .01
MATEI SE
INTER

100410

DSO 210-1 (REV 6-84)

REVISIONS				
REV	DESCRIPTION	AUTH.	DATE	APPROVED

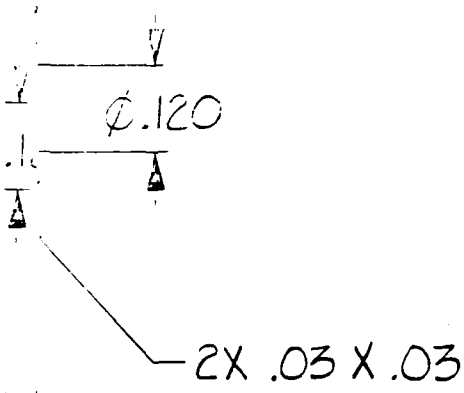

REFERENCE ONLY

THE PART NUMBER IS THE DRAWING NUMBER AND THE DASH NUMBER THAT APPLIES

UNLESS OTHERWISE SPECIFIED DIMENSIONS ARE IN INCHES TOLERANCES ON 2 PLACE DECIMALS ± .02 3 PLACE DECIMALS ± .005 ± - ANGLES - MATERIAL SEE NOTE 1	CONTR. NO DFT <i>S. Allen</i> 87-4-27	Delco Systems Operations GENERAL MOTORS CORPORATION GOLETA, CALIFORNIA	
	CHKR ENGR <i>[Signature]</i> 87-4-29	TITLE SCREW, LOCKING	
INTERPRET DRAWING PER DOD-STD-100	APVD DSGN ACTIVITY APVD	SIZE B FSCM NO. 13160 SCALE 4/1	DWG NO. SK100471 REV - SHEET 1 OF 1

REF E41

1

2

NOTES:

1. MATL: STEEL CRES
TYPE 303 SE OR 303 SU
COND A.
2. REMOVE BURRS AND
BREAK SHARP EDGES.

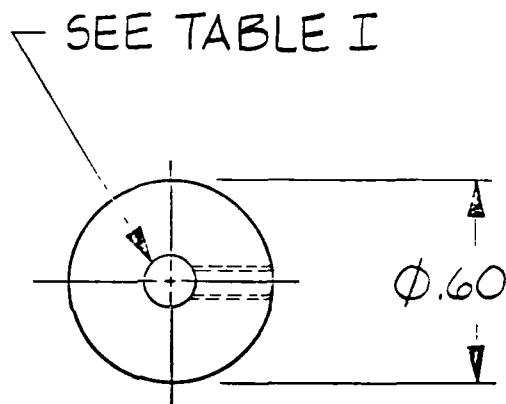

TABLE I

PN	HOLE DIA
-001	ϕ .1505 ϕ .1500 \downarrow .60
-002	ϕ .1005 ϕ .1000 \downarrow .60

TI
UNLESS OTHER DIMENSIONS
TOLER
2 PLACE 3
DECIMALS DE
+ - ±
MATERIAL
SEE N
INTERPRET DOD-

100410

REVISIONS

REV	DESCRIPTION	AUTH.	DATE	APPROVED

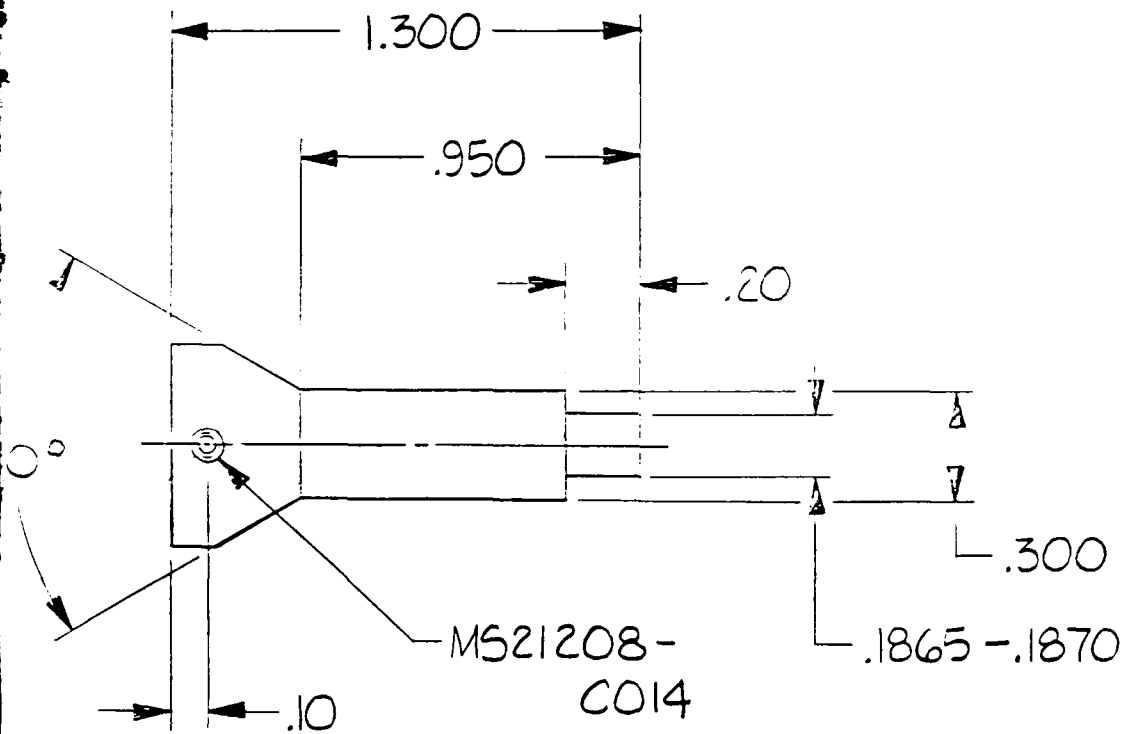

REFERENCE ONLY

THE PART NUMBER IS THE DRAWING NUMBER AND THE DASH NUMBER THAT APPLIES

UNLESS OTHERWISE SPECIFIED
DIMENSIONS ARE IN INCHES

TOLERANCES ON
2 PLACE 3 PLACE ANGLES
DECIMALS DECIMALS

± - ± .005 ± 1°

CONTR. NO -

DFT *S. Allen* 37-4-22

CHKR

ENGR *Amundt* 37-4-29

APVD APVD

DSGN ACTIVITY APVD

Delco Systems Operations

GENERAL MOTORS CORPORATION GOLETA, CALIFORNIA

TITLE

MOUNT, GAGE

MATERIAL
SEE NOTE 1

REF **E41**

SIZE **B** FSCM NO. **13160** DWG NO. **SK100467** REV -

INTERPRET DRAWING PER DOD-STD-100

DO NOT SCALE DWG

SCALE 2/1 SHEET 1 OF 1

Handwritten marks: a triangle pointing up, a vertical line, and a cursive signature.

NOTES:

1. MATL: AL ALLOY
6061-TEMPER T6,
.040 THK
2. REMOVE BURRS AND
BREAK SHARP EDGES.

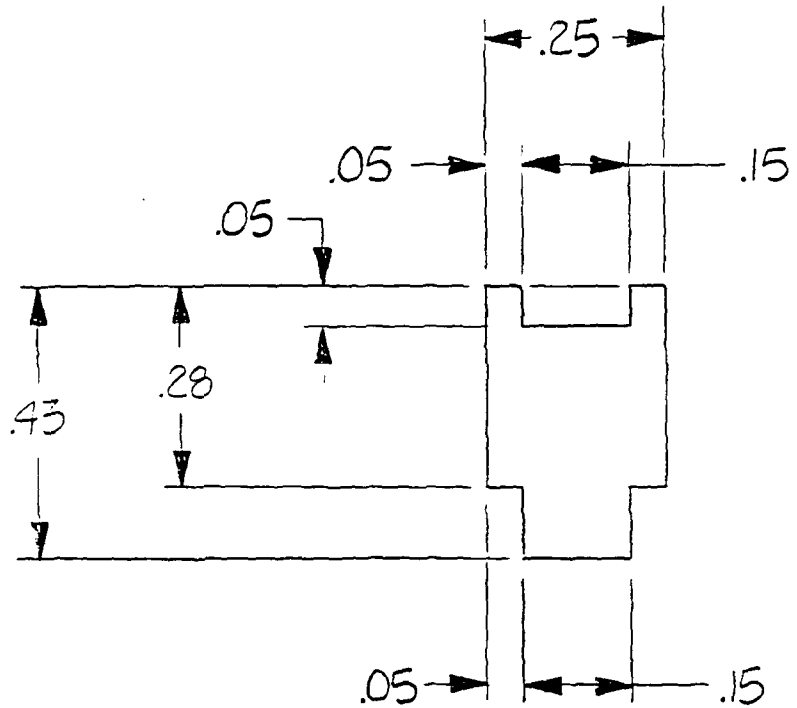

UNLESS OT DIMENSION TOLE
2 PLACE DECIMALS ± .02
MATERIAL AL AL
INTERPRE DOC

100410



REVISIONS				
REV	DESCRIPTION	AUTH.	DATE	APPROVED

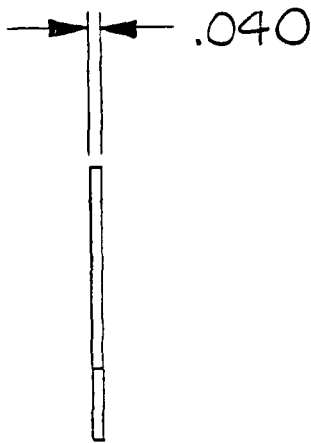

REFERENCE ONLY

THE PART NUMBER IS THE DRAWING NUMBER AND THE DASH NUMBER THAT APPLIES

UNLESS OTHERWISE SPECIFIED
DIMENSIONS ARE IN INCHES

TOLERANCES ON

2 PLACE DECIMALS	3 PLACE DECIMALS	ANGLES
± .02	±	± -

CONTR. NO

DFT *S. Allen*

CHKR

ENGR *Jim Hudson* 37-4-27

APVD

APVD

DSGN ACTIVITY APVD

Delco Systems Operations

GENERAL MOTORS CORPORATION GOLETA, CALIFORNIA

TITLE

FLAG INTERRUPT

MATERIAL

AL ALLOY 6061

SIZE	FSCM NO.	DWG NO.	REV
B	13160	SK100466	-

INTERPRET DRAWING PER
DOD-STD-100

DO NOT SCALE DWG

REF **E41**

SCALE 4/1

SHEET 1 OF 1



1

2

NOTES:

1. MATL: STEEL CRES
TYPE 303 SE OR 303 SU
COND A

2. REMOVE BURRS AND
BREAK SHARP EDGES.

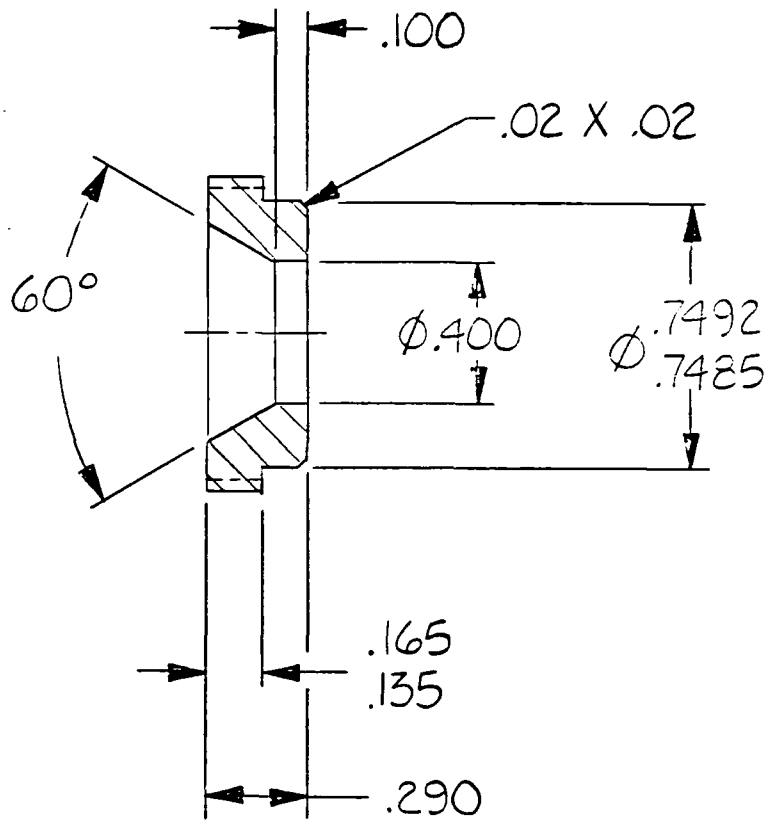

TH
UNLESS OTHER DIMENSIONS
TOLER
2 PLACE 3
DECIMALS DE
± .01 ±
MATERIAL
SEE N
INTERPRET DOD-

100410

HS

JMU

REVISIONS

REV	DESCRIPTION	AUTH.	DATE	APPROVED

.875-28UNF-2A

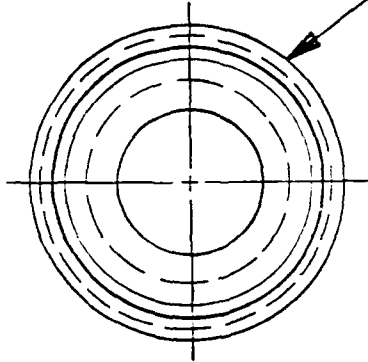

REFERENCE ONLY

THE PART NUMBER IS THE DRAWING NUMBER AND THE DASH NUMBER THAT APPLIES

UNLESS OTHERWISE SPECIFIED
DIMENSIONS ARE IN INCHES

TOLERANCES ON

PLACE	3 PLACE	ANGLES
DECIMALS	DECIMALS	
±.01	±.005	±1°

CONTR. NO	
DFT <i>S. Allen</i>	87-4-26
CHKR	
ENGR <i>Allen</i>	87-4-29
APVD	APVD
DSGN ACTIVITY APVD	

Delco Systems Operations

GENERAL MOTORS CORPORATION GOLETA, CALIFORNIA

TITLE: **NUT, END**

MATERIAL: **SEE NOTE 1**

INTERPRET DRAWING PER DOD-STD-100

DO NOT SCALE DWG	REF E41
------------------	----------------

SIZE B	FSCM NO. 13160	DWG NO. SK100466	REV -
SCALE 2/1		SHEET 1 OF 1	

PAR
SE S
: IN
ES
E
LS
05
TE
AWIN
)-10

▲ 1 2

NOTES:

1. MATERIAL: STEEL CRES
TYPE 303 SE OR 303 SU
CONDITION A.
2. REMOVE ALL BURRS AND
BREAK SHARP EDGES.

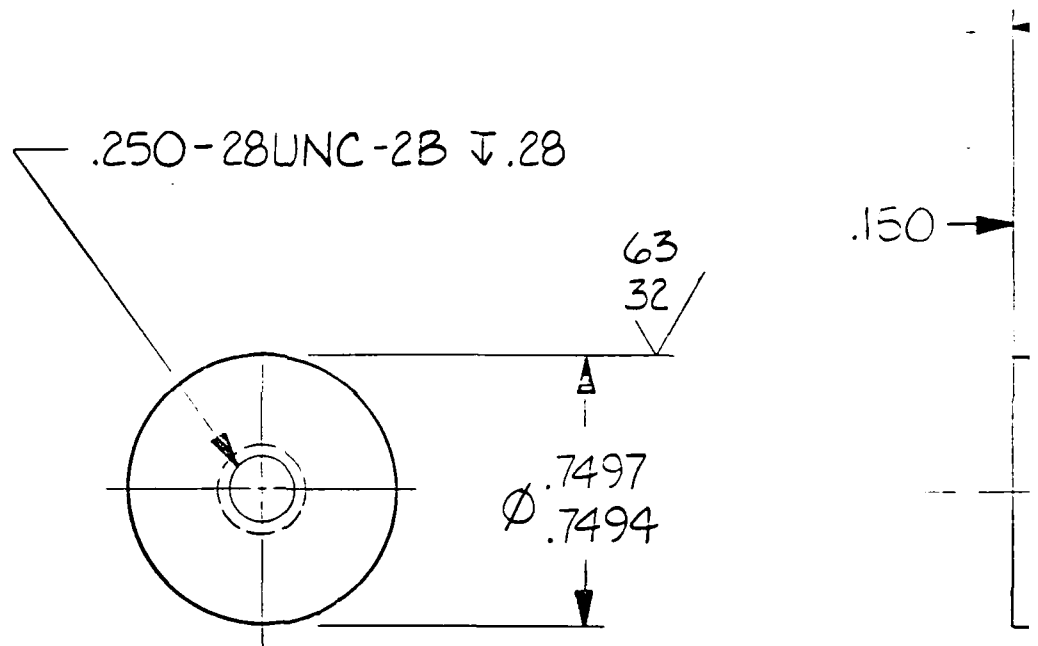

UNLESS OTHERWISE SPECIFIED
DIMENSIONS ARE IN INCHES
DECIMALS
TOLERANCES
$\pm .02$
MATERIAL
SEE 1
INTERPRETATION
DOD

REVISIONS				
REV	DESCRIPTION	AUTH.	DATE	APPROVED

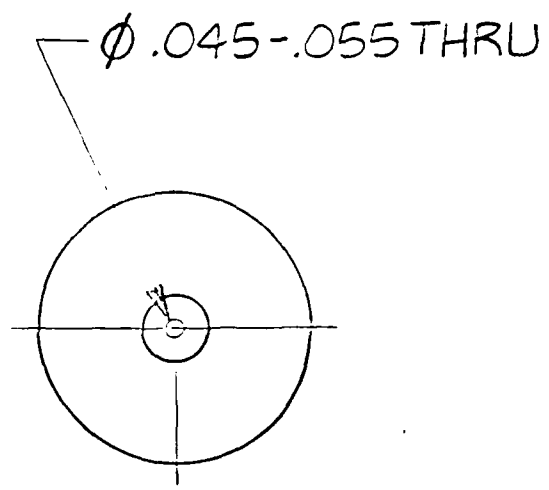
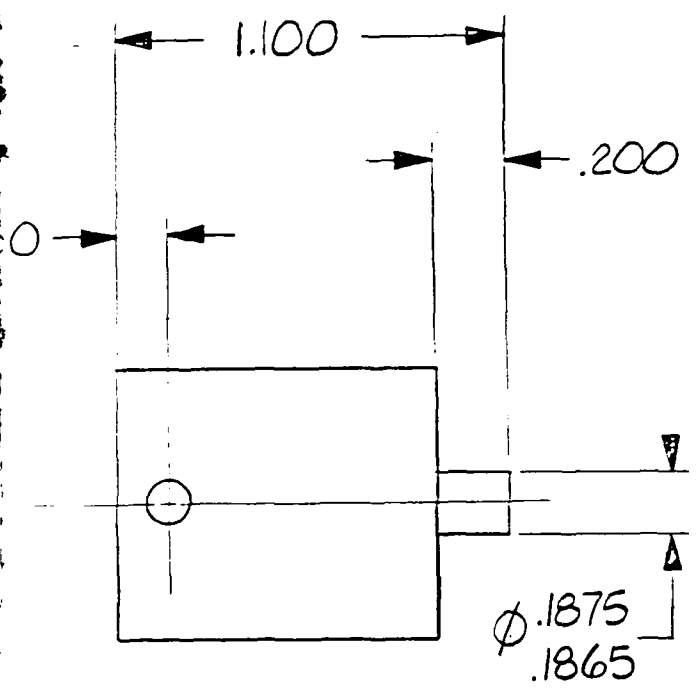

REFERENCE ONLY

THE PART NUMBER IS THE DRAWING NUMBER AND THE DASH NUMBER THAT APPLIES UNLESS OTHERWISE SPECIFIED DIMENSIONS ARE IN INCHES				
TOLERANCES ON 2 PLACE DECIMALS $\pm .02$ 3 PLACE DECIMALS $\pm .005$ ANGLES $\pm -$		CONTR. NO. — DFT <i>S. Allen</i> 87-4.27 CHKR ENGR <i>subler</i> 87-4.29	Delco Systems Operations GENERAL MOTORS CORPORATION GOLETA, CALIFORNIA	
MATERIAL SEE NOTE 1		APVD APVD DSGN ACTIVITY APVD	TITLE PISTON	
INTERPRET DRAWING PER DOD-STD-100		DO NOT SCALE DWG REF E41	SIZE B FSCM NO. 13160 SCALE 2/1	DWG NO. SK100470 REV — SHEET 1 OF 1

1 / 2

NOTES:

- 1. MATERIAL: STEEL CRES
TYPE 303 SE OR 303 SU
CONDITION A.
- 2. REMOVE BURRS AND
BREAK SHARP EDGES.

D
C
B
A

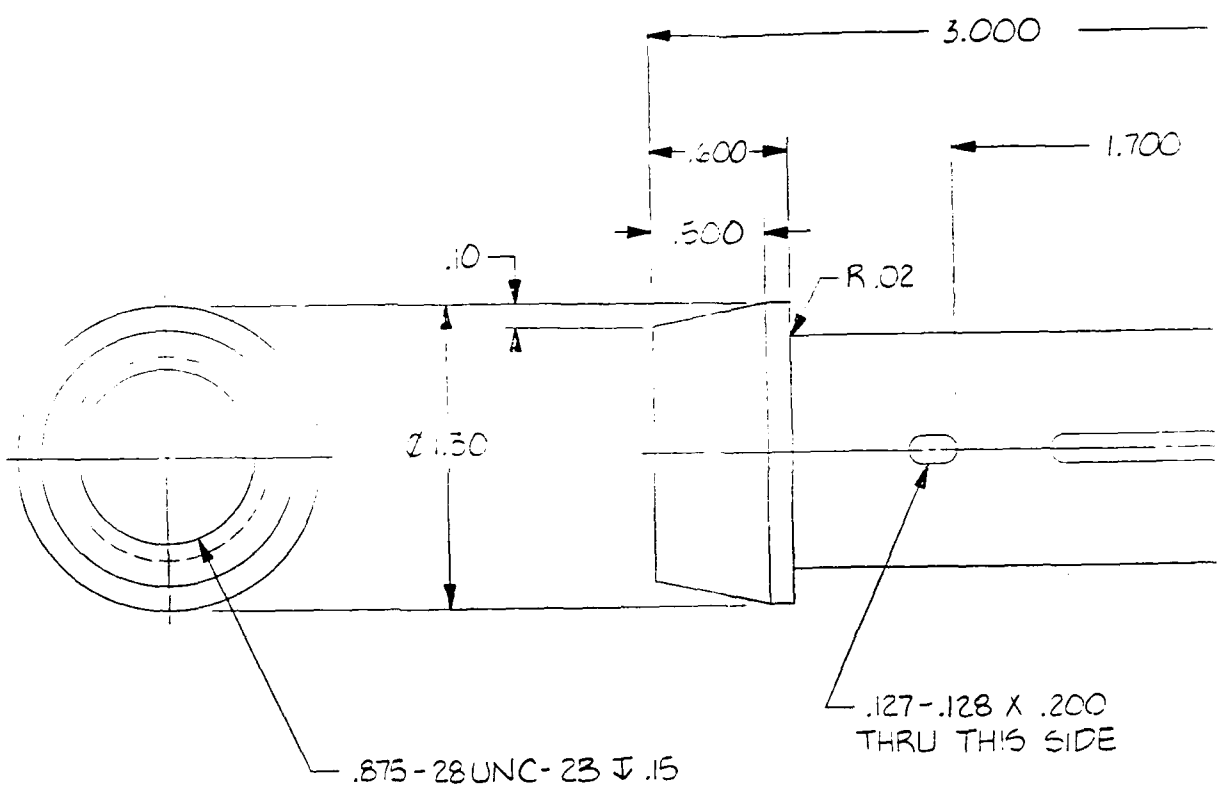

REVISIONS				
REV	DESCRIPTION	AUTH.	DATE	APPROVED

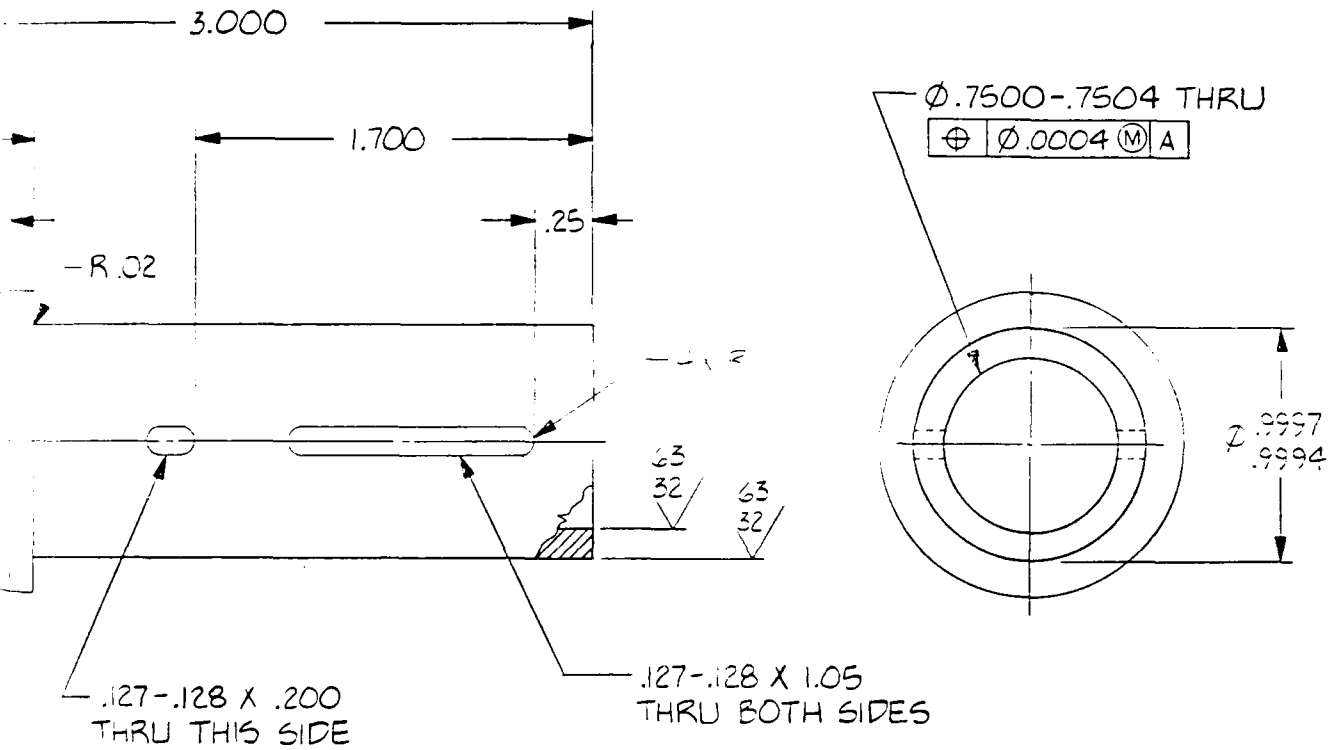

REFERENCE ONLY

UNLESS OTHERWISE SPECIFIED DIMENSIONS ARE IN INCHES				
TOLERANCES ON 2 PLACE DECIMALS $\pm .01$ 3 PLACE DECIMALS $\pm .005$ ANGLES $\pm -$		CONTR. NO. — DFT <i>S. Allen</i> 57-4-29 CHKR ENGR <i>[Signature]</i> 87-4-29	Delco Systems Operations GENERAL MOTORS CORPORATION GOLETA CALIFORNIA	
MATERIAL SEE NOTE 1		APVD APVD DSGN ACTIVITY APVD	TITLE SLIDER	
INTERPRET DRAWING PER DOD-STD-100		DO NOT SCALE DWG REF E41	SIZE C 13160 SCALE 2/1	DWG NO. SK100468 REV —

D

C

DWG NO SK100468

A