

# Project Management for Construction

## Fundamental Concepts for Owners, Engineers, Architects and Builders

1. [The Owners' Perspective](#)
2. [Organizing For Project Management](#)
3. [The Design And Construction Process](#)
4. [Labor, Material, And Equipment Utilization](#)
5. [Cost Estimation](#)
6. [Economic Evaluation of Facility Investments](#)
7. [Financing of Constructed Facilities](#)
8. [Construction Pricing and Contracting](#)
9. [Construction Planning](#)
10. [Fundamental Scheduling Procedures](#)
11. [Advanced Scheduling Techniques](#)
12. [Cost Control, Monitoring, and Accounting](#)
13. [Quality Control and Safety During Construction](#)
14. [Organization and Use of Project Information](#)

<http://pmbook.ce.cmu.edu/>

by Chris Hendrickson, Department of Civil and Environmental Engineering, Carnegie Mellon University, Pittsburgh, PA 15213 Copyright C. Hendrickson 1998

First Edition originally printed by Prentice Hall, ISBN 0-13-731266-0, 1989 with co-author Tung Au.

Second Edition prepared for world wide web publication in 2000.

Version 2.2 prepared Summer, 2008.

### Preface

This book is provided on the worldwide web as a service to the community of practitioners and students. Reproduction for educational purposes is permitted with appropriate citation. If you find this work helpful or have suggestions for additions or corrections, please email Chris Hendrickson: [cth@cmu.edu](mailto:cth@cmu.edu). A hardcopy Instructor's Manual with problem solutions is available for a fee of \$ 10 to cover reproduction, mailing and handling. Send a check made out to Carnegie Mellon University to Ms. Patty Langer, Department of Civil and Environmental Engineering, Carnegie Mellon University, Pittsburgh, PA 15213.

This book develops a specific viewpoint in discussing the participants, the processes and the techniques of project management for construction. This viewpoint is that of owners who desire completion of projects in a timely, cost effective fashion. Some profound implications for the objectives and methods of project management result from this perspective:

- The "life cycle" of costs and benefits from initial planning through operation and disposal of a facility are relevant to decision making. An owner is concerned with a project from the cradle to the grave. Construction costs represent only one portion of the overall life cycle costs.
- Optimizing performance at one stage of the process may not be beneficial overall if additional

costs or delays occur elsewhere. For example, saving money on the design process will be a false economy if the result is excess construction costs.

- Fragmentation of project management among different specialists may be necessary, but good communication and coordination among the participants is essential to accomplish the overall goals of the project. New information technologies can be instrumental in this process, especially the Internet and specialized Extranets.
- Productivity improvements are always of importance and value. As a result, introducing new materials and automated construction processes is always desirable as long as they are less expensive and are consistent with desired performance.
- Quality of work and performance are critically important to the success of a project since it is the owner who will have to live with the results.

In essence, adopting the viewpoint of the owner focuses attention on the cost effectiveness of facility construction rather than competitive provision of services by the various participants.

While this book is devoted to a particular viewpoint with respect to project management for construction, it is not solely intended for owners and their direct representatives. By understanding the entire process, all participants can respond more effectively to the owner's needs in their own work, in marketing their services, and in communicating with other participants. In addition, the specific techniques and tools discussed in this book (such as economic evaluation, scheduling, management information systems, etc.) can be readily applied to any portion of the process.

As a result of the focus on the effective management of entire projects, a number of novel organizational approaches and techniques become of interest. First and foremost is the incentive to replace confrontation and adversarial relationships with a spirit of joint endeavor, partnership and accomplishment. For example, we discuss the appropriate means to evaluate risks and the appropriate participants to assume the unavoidable risks associated with constructed facilities. Scheduling, communication of data, and quality assurance have particular significance from the viewpoint of an owner, but not necessarily for individual participants. The use of computer-based technology and automation also provides opportunities for increased productivity in the process. Presenting such modern management options in a unified fashion is a major objective of this book.

The unified viewpoint of the entire process of project management in this book differs from nearly all other literature on the subject. Most textbooks in the area treat special problems, such as cost estimating, from the viewpoint of particular participants such as construction managers or contractors. This literature reflects the fragmentation of the construction process among different organizations and professionals. Even within a single profession such as civil engineering, there are quite distinct groups of specialists in planning, design, management, construction and other sub-specialties. Fragmentation of interest and attention also exists in nearly all educational programs. While specialty knowledge may be essential to accomplish particular tasks, participants in the process should also understand the context and role of their special tasks.

This book is intended primarily as a text for advanced undergraduates, beginning graduate students or professionals continuing their education in engineering, construction, architecture or facilities management. Examples and discussion are chosen to remind readers that project management is a challenging, dynamic and exciting enterprise and not just a record of past practices. It should also be useful to professionals who wish an up-to-date reference on project management.

Chapters 1 to 3 present an overview of the construction management and design process which should be of interest to anyone engaged in project management for construction. One need not have detailed knowledge about individual tasks or techniques for this part. Individuals can read these chapters and

understand the basic philosophy and principles without further elaboration.

Chapters 4 through 14 describe specific functions and techniques useful in the process of project management. This part presents techniques and requirements during project planning, including risk assessment, cost estimation, forecasting and economic evaluation. It is during this planning and design phase in which major cost savings may be obtained during the eventual construction and operation phases. It also addresses programming and financing issues, such as contracting and bidding for services, financing, organizing communication and insuring effective use of information. It further discusses techniques for control of time, cost and quality during the construction phase. Beginning courses in engineering economics (including cash flow analysis and discounting), use of computers, probability and statistics would be useful. Furthermore, access to a personal computer with spreadsheet or equation solving software would be helpful for readers attempting some of the problems in Chapters 4 to 14. Numerous software programs could be used for this purpose, including both spreadsheet and equation solving programs. Problems in some chapters could also be done on any number of existing software packages for information management and project scheduling. However, the use of personal computers in this fashion is not required in following the text material. Each instructor may exercise discretion in omitting some of the material in these chapters if they are redundant with other classes or too advanced for students in his or her own class.

It is our hope that students beginning their career in project management for construction will be prepared to adopt the integrated approach emphasized in this book. Furthermore, experienced professionals in various fields may discover in this book some surprises that even they have not anticipated. High level decision makers in owner organizations who are not directly involved in the project management process may find the basic philosophy and principles of interest, especially in Chapters 1 through 3, as owners must invariably pay for constructed facilities, for better or worse. If the book can fulfill even a small part of its promises to influence the future of project management for construction, our efforts will have been amply rewarded.

For version 2.1 (Summer 2003), a number of new examples, updates and references have been inserted throughout the text. For example, there are new discussions of lean construction and green buildings. However, the basic structure and methods remain the same. The fundamentals of project management treated here are timeless.

Numerous individuals helped with the preparation of the first and second editions of this book. In particular, we wish to acknowledge Burcu Akinci, William J. Hall, Paul Christiano, Steven Fenves, Daniel Rehak, Debbie Scappatura, and Shirley Knapp. Iavor Kostov, Tommy Hendrickson, Curt Yeske and In-Soo Jung were instrumental in developing the web version of this book. This book also reflects the contributions of numerous students and colleagues in industry who have challenged us with problems and shared their own ideas and experience over many years. We are grateful to all of these individuals.

Some material in this book has been taken from several papers authored by us and published by the American Society of Civil Engineers. Materials taken from other sources are acknowledged in footnotes, tables or figures. We gratefully acknowledge the permissions given to us by these individuals, publishers and organizations.

A series of photographs depicting various stages of construction of the PPG building in Pittsburgh, PA is inserted in sequence between chapters. We wish to thank PPG Industries for its cooperation in providing these photographs.

Chris Hendrickson and Tung Au

<a href="#">Go Up to Table of Contents</a>
<a href="#">Go To Chapter 2 (Organizing for Project Management)</a>
<i>The Owners' Perspective</i>
<a href="#">Introduction</a>
<a href="#">The Project Life Cycle</a>
<a href="#">Major Types of Construction</a>
<a href="#">Selection of Professional Services</a>
<a href="#">Construction Contractors</a>
<a href="#">Financing of Constructed Facilities</a>
<a href="#">Legal and Regulatory Requirements</a>
<a href="#">The Changing Environment of the Construction Industry</a>
<a href="#">The Role of Project Managers</a>
<a href="#">References</a>
<a href="#">Footnotes</a>

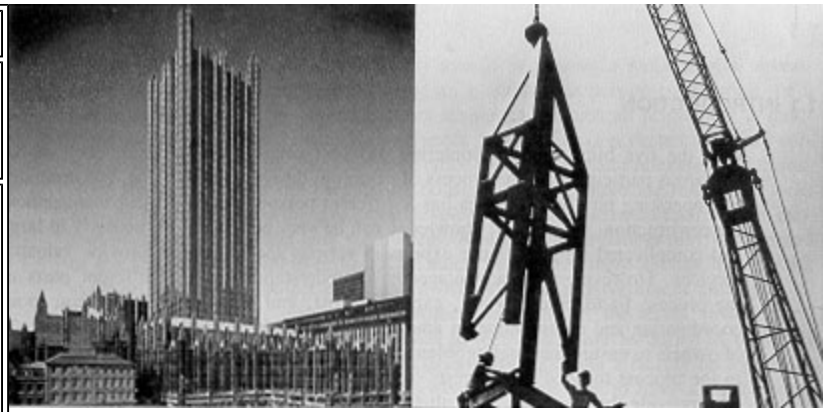

[http://pmbook.ce.cmu.edu/01\\_The\\_Owners'\\_Perspective.html](http://pmbook.ce.cmu.edu/01_The_Owners'_Perspective.html)

# 1. The Owners' Perspective

## 1.1 Introduction

Like the five blind men encountering different parts of an elephant, each of the numerous participants in the process of planning, designing, financing, constructing and operating physical facilities has a different perspective on project management for construction. Specialized knowledge can be very beneficial, particularly in large and complicated projects, since experts in various specialties can provide valuable services. However, it is advantageous to understand how the different parts of the process fit together. Waste, excessive cost and delays can result from poor coordination and communication among specialists. It is particularly in the interest of owners to insure that such problems do not occur. And it behooves all participants in the process to heed the interests of owners because, in the end, it is the owners who provide the resources and call the shots.

By adopting the viewpoint of the owners, we can focus our attention on the complete process of *project management* for constructed facilities rather than the historical roles of various specialists such as planners, architects, engineering designers, constructors, fabricators, material suppliers, financial analysts and others. To be sure, each specialty has made important advances in developing new techniques and tools for efficient implementation of construction projects. However, it is through the understanding of the entire process of project management that these specialists can respond more effectively to the owner's desires for their services, in marketing their specialties, and in improving the productivity and quality of their work.

The introduction of innovative and more effective project management for construction is not an academic exercise. As reported by the "Construction Industry Cost Effectiveness Project" of the Business Roundtable: [\[1\]](#)

By common consensus and every available measure, the United States no longer gets its money's worth in construction, the nation's largest industry ... The creeping erosion of construction efficiency and productivity is bad news for the entire U.S. economy.

Construction is a particularly seminal industry. The price of every factory, office building, hotel or power plant that is built affects the price that must be charged for the goods or services produced in it or by it. And that effect generally persists for decades ... Too much of the industry remains tethered to the past, partly by inertia and partly by historic divisions...

Improvement of project management not only can aid the construction industry, but may also be the engine for the national and world economy. However, if we are to make meaningful improvements, we must first understand the construction industry, its operating environment and the institutional constraints affecting its activities as well as the nature of project management.

[Back to top](#)

## 1.2 The Project Life Cycle

The acquisition of a constructed facility usually represents a major capital investment, whether its owner happens to be an individual, a private corporation or a public agency. Since the commitment of resources for such an investment is motivated by market demands or perceived needs, the facility is expected to satisfy certain objectives within the constraints specified by the owner and relevant regulations. With the exception of the speculative housing market, where the residential units may be sold as built by the real estate developer, most constructed facilities are custom made in consultation with the owners. A real estate developer may be regarded as the sponsor of building projects, as much as a government agency may be the sponsor of a public project and turns it over to another government unit upon its completion. From the viewpoint of project management, the terms "owner" and "sponsor" are synonymous because both have the ultimate authority to make all important decisions. Since an owner is essentially acquiring a facility on a promise in some form of agreement, it will be wise for any owner to have a clear understanding of the acquisition process in order to maintain firm control of the quality, timeliness and cost of the completed facility.

From the perspective of an owner, the project life cycle for a constructed facility may be illustrated schematically in Figure 1-1. Essentially, a project is conceived to meet market demands or needs in a timely fashion. Various possibilities may be considered in the conceptual planning stage, and the technological and economic feasibility of each alternative will be assessed and compared in order to select the best possible project. The financing schemes for the proposed alternatives must also be examined, and the project will be programmed with respect to the timing for its completion and for available cash flows. After the scope of the project is clearly defined, detailed engineering design will provide the blueprint for construction, and the definitive cost estimate will serve as the baseline for cost control. In the procurement and construction stage, the delivery of materials and the erection of the project on site must be carefully planned and controlled. After the construction is completed, there is usually a brief period of start-up or shake-down of the constructed facility when it is first occupied. Finally, the management of the facility is turned over to the owner for full occupancy until the facility lives out its useful life and is designated for demolition or conversion.

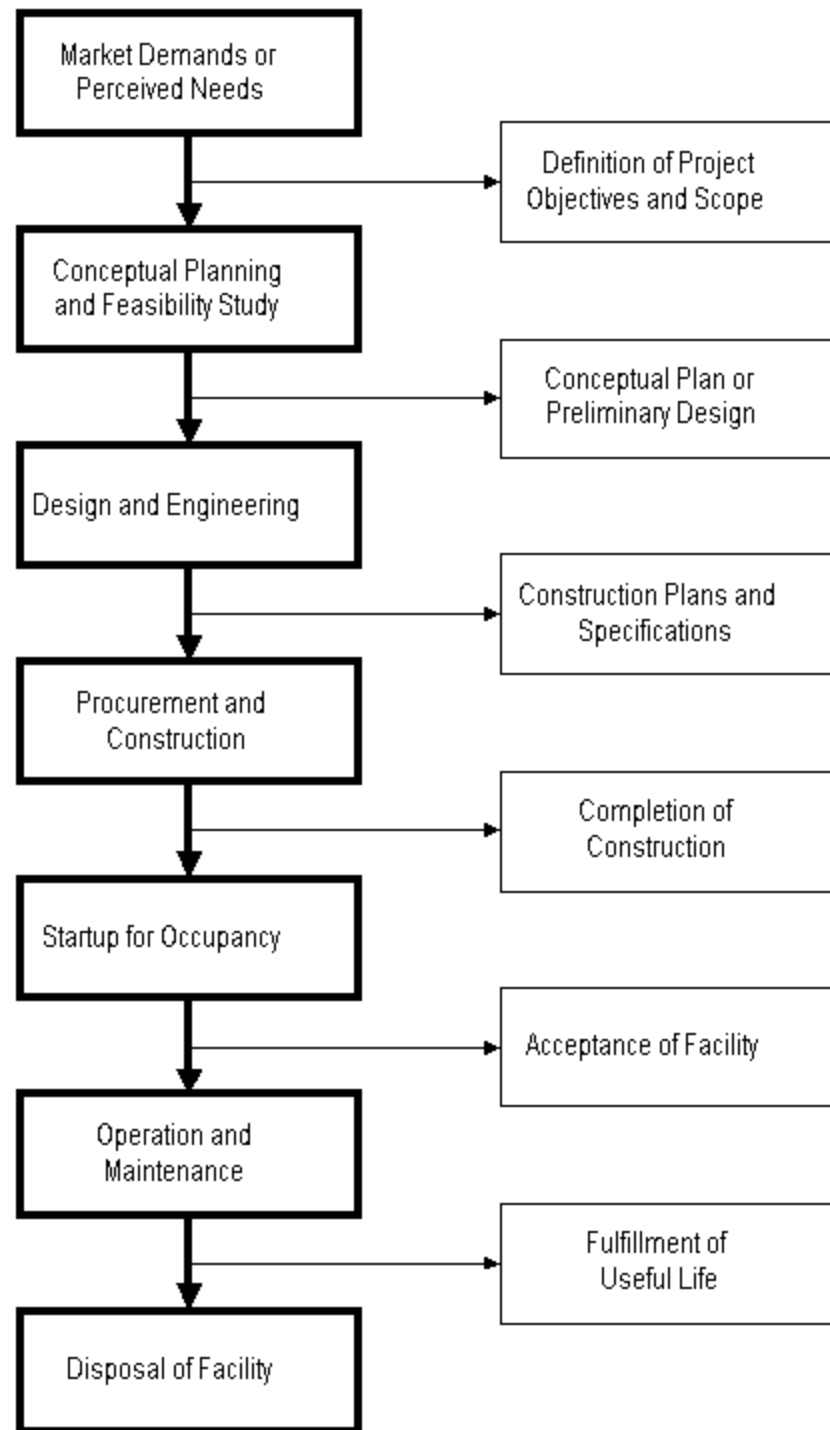

**Figure 1-1:** The Project Life Cycle of a Constructed Facility

Of course, the stages of development in Figure 1-1 may not be strictly sequential. Some of the stages require iteration, and others may be carried out in parallel or with overlapping time frames, depending on the nature, size and urgency of the project. Furthermore, an owner may have in-house capacities to handle the work in every stage of the entire process, or it may seek professional advice and services for the work in all stages. Understandably, most owners choose to handle some of the work in-house and to contract outside professional services for other components of the work as needed. By examining the

project life cycle from an owner's perspective we can focus on the proper roles of various activities and participants in all stages regardless of the contractual arrangements for different types of work.

In the United States, for example, the U.S. Army Corps of Engineers has in-house capabilities to deal with planning, budgeting, design, construction and operation of waterway and flood control structures. Other public agencies, such as state transportation departments, are also deeply involved in all phases of a construction project. In the private sector, many large firms such as DuPont, Exxon, and IBM are adequately staffed to carry out most activities for plant expansion. All these owners, both public and private, use outside agents to a greater or lesser degree when it becomes more advantageous to do so.

The project life cycle may be viewed as a process through which a project is implemented from cradle to grave. This process is often very complex; however, it can be decomposed into several stages as indicated by the general outline in Figure 1-1. The solutions at various stages are then integrated to obtain the final outcome. Although each stage requires different expertise, it usually includes both technical and managerial activities in the *knowledge domain* of the specialist. The owner may choose to decompose the entire process into more or less stages based on the size and nature of the project, and thus obtain the most efficient result in implementation. Very often, the owner retains direct control of work in the planning and programming stages, but increasingly outside planners and financial experts are used as consultants because of the complexities of projects. Since operation and maintenance of a facility will go on long after the completion and acceptance of a project, it is usually treated as a separate problem except in the consideration of the life cycle cost of a facility. All stages from conceptual planning and feasibility studies to the acceptance of a facility for occupancy may be broadly lumped together and referred to as the Design/Construct process, while the procurement and construction alone are traditionally regarded as the province of the construction industry.

Owners must recognize that there is no single best approach in organizing project management throughout a project's life cycle. All organizational approaches have advantages and disadvantages, depending on the knowledge of the owner in construction management as well as the type, size and location of the project. It is important for the owner to be aware of the approach which is most appropriate and beneficial for a particular project. In making choices, owners should be concerned with the life cycle costs of constructed facilities rather than simply the initial construction costs. Saving small amounts of money during construction may not be worthwhile if the result is much larger operating costs or not meeting the functional requirements for the new facility satisfactorily. Thus, owners must be very concerned with the quality of the finished product as well as the cost of construction itself. Since facility operation and maintenance is a part of the project life cycle, the owners' expectation to satisfy investment objectives during the project life cycle will require consideration of the cost of operation and maintenance. Therefore, the facility's operating management should also be considered as early as possible, just as the construction process should be kept in mind at the early stages of planning and programming.

[Back to top](#)

## 1.3 Major Types of Construction

Since most owners are generally interested in acquiring only a specific type of constructed facility, they should be aware of the common industrial practices for the type of construction pertinent to them. Likewise, the *construction industry* is a conglomeration of quite diverse segments and products. Some owners may procure a constructed facility only once in a long while and tend to look for short term advantages. However, many owners require periodic acquisition of new facilities and/or rehabilitation of existing facilities. It is to their advantage to keep the construction industry healthy and productive.

Collectively, the owners have more power to influence the construction industry than they realize because, by their individual actions, they can provide incentives or disincentives for innovation, efficiency and quality in construction. It is to the interest of all parties that the owners take an active interest in the construction and exercise beneficial influence on the performance of the industry.

In planning for various types of construction, the methods of procuring professional services, awarding construction contracts, and financing the constructed facility can be quite different. For the purpose of discussion, the broad spectrum of constructed facilities may be classified into four major categories, each with its own characteristics.

## **Residential Housing Construction**

Residential housing construction includes single-family houses, multi-family dwellings, and high-rise apartments. During the development and construction of such projects, the developers or sponsors who are familiar with the construction industry usually serve as surrogate owners and take charge, making necessary contractual agreements for design and construction, and arranging the financing and sale of the completed structures. Residential housing designs are usually performed by architects and engineers, and the construction executed by builders who hire subcontractors for the structural, mechanical, electrical and other specialty work. An exception to this pattern is for single-family houses which may be designed by the builders as well.

The residential housing market is heavily affected by general economic conditions, tax laws, and the monetary and fiscal policies of the government. Often, a slight increase in total demand will cause a substantial investment in construction, since many housing projects can be started at different locations by different individuals and developers at the same time. Because of the relative ease of entry, at least at the lower end of the market, many new builders are attracted to the residential housing construction. Hence, this market is highly competitive, with potentially high risks as well as high rewards.



**Figure 1-2:** Residential Housing Construction (courtesy of Caterpillar, Inc.)

## **Institutional and Commercial Building Construction**

Institutional and commercial building construction encompasses a great variety of project types and sizes, such as schools and universities, medical clinics and hospitals, recreational facilities and sports stadiums, retail chain stores and large shopping centers, warehouses and light manufacturing plants, and skyscrapers for offices and hotels. The owners of such buildings may or may not be familiar with construction industry practices, but they usually are able to select competent professional consultants and arrange the financing of the constructed facilities themselves. Specialty architects and engineers are



often engaged for designing a specific type of building, while the builders or general contractors undertaking such projects may also be specialized in only that type of building.

Because of the higher costs and greater sophistication of institutional and commercial buildings in comparison with residential housing, this market segment is shared by fewer competitors. Since the construction of some of these buildings is a long process which once started will take some time to proceed until completion, the demand is less sensitive to general economic conditions than that for speculative housing. Consequently, the owners may confront an *oligopoly* of general contractors who compete in the same market. In an oligopoly situation, only a limited number of competitors exist, and a firm's price for services may be based in part on its competitive strategies in the local market.



**Figure 1-3:** Construction of the PPG Building in Pittsburgh, Pennsylvania (courtesy of PPG Industries, Inc.)

## Specialized Industrial Construction

Specialized industrial construction usually involves very large scale projects with a high degree of technological complexity, such as oil refineries, steel mills, chemical processing plants and coal-fired or nuclear power plants. The owners usually are deeply involved in the development of a project, and prefer to work with designers-builders such that the total time for the completion of the project can be shortened. They also want to pick a team of designers and builders with whom the owner has developed good working relations over the years.

Although the initiation of such projects is also affected by the state of the economy, long range demand forecasting is the most important factor since such projects are capital intensive and require considerable amount of planning and construction time. Governmental regulation such as the rulings of the Environmental Protection Agency and the Nuclear Regulatory Commission in the United States can also profoundly influence decisions on these projects.

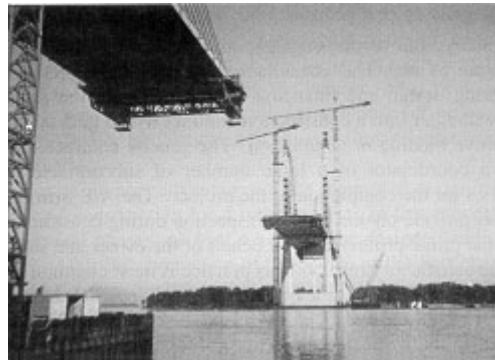

**Figure 1-4:** Construction of a Benzene Plant in Lima, Ohio (courtesy of Manitowoc Company, Inc.)

## Infrastructure and Heavy Construction

Infrastructure and heavy construction includes projects such as highways, mass transit systems, tunnels, bridges, pipelines, drainage systems and sewage treatment plants. Most of these projects are publicly owned and therefore financed either through bonds or taxes. This category of construction is characterized by a high degree of mechanization, which has gradually replaced some labor intensive operations.

The engineers and builders engaged in infrastructure construction are usually highly specialized since each segment of the market requires different types of skills. However, demands for different segments of infrastructure and heavy construction may shift with saturation in some segments. For example, as the available highway construction projects are declining, some heavy construction contractors quickly move their work force and equipment into the field of mining where jobs are available.



**Figure 1-5:** Construction of the Dame Point Bridge in Jacksonville, Florida (courtesy of Mary Lou Maher)

[Back to top](#)

## 1.4 Selection of Professional Services

When an owner decides to seek professional services for the design and construction of a facility, he is confronted with a broad variety of choices. The type of services selected depends to a large degree on the type of construction and the experience of the owner in dealing with various professionals in the previous projects undertaken by the firm. Generally, several common types of professional services may be engaged either separately or in some combination by the owners.

### Financial Planning Consultants

At the early stage of strategic planning for a capital project, an owner often seeks the services of financial planning consultants such as certified public accounting (CPA) firms to evaluate the economic and financial feasibility of the constructed facility, particularly with respect to various provisions of federal, state and local tax laws which may affect the investment decision. Investment banks may also be consulted on various options for financing the facility in order to analyze their long-term effects on the financial health of the owner organization.

### Architectural and Engineering Firms

Traditionally, the owner engages an architectural and engineering (A/E) firm or consortium as technical consultant in developing a preliminary design. After the engineering design and financing arrangements for the project are completed, the owner will enter into a construction contract with a general contractor either through competitive bidding or negotiation. The general contractor will act as a constructor and/or a coordinator of a large number of subcontractors who perform various specialties for the completion of the project. The A/E firm completes the design and may also provide on site quality inspection during construction. Thus, the A/E firm acts as the prime professional on behalf of the owner and supervises the construction to insure satisfactory results. This practice is most common in building construction.

In the past two decades, this traditional approach has become less popular for a number of reasons, particularly for large scale projects. The A/E firms, which are engaged by the owner as the prime professionals for design and inspection, have become more isolated from the construction process. This has occurred because of pressures to reduce fees to A/E firms, the threat of litigation regarding construction defects, and lack of knowledge of new construction techniques on the part of architect and engineering professionals. Instead of preparing a construction plan along with the design, many A/E firms are no longer responsible for the details of construction nor do they provide periodic field inspection in many cases. As a matter of fact, such firms will place a prominent disclaimer of responsibilities on any shop drawings they may check, and they will often regard their representatives in the field as observers instead of inspectors. Thus, the A/E firm and the general contractor on a project often become antagonists who are looking after their own competing interests. As a result, even the constructibility of some engineering designs may become an issue of contention. To carry this protective attitude to the extreme, the specifications prepared by an A/E firm for the general contractor often protects the interest of the A/E firm at the expense of the interests of the owner and the contractor.

In order to reduce the cost of construction, some owners introduce *value engineering*, which seeks to reduce the cost of construction by soliciting a second design that might cost less than the original design produced by the A/E firm. In practice, the second design is submitted by the contractor after receiving a construction contract at a stipulated sum, and the saving in cost resulting from the redesign is shared by the contractor and the owner. The contractor is able to absorb the cost of redesign from the profit in

construction or to reduce the construction cost as a result of the re-design. If the owner had been willing to pay a higher fee to the A/E firm or to better direct the design process, the A/E firm might have produced an improved design which would cost less in the first place. Regardless of the merit of value engineering, this practice has undermined the role of the A/E firm as the prime professional acting on behalf of the owner to supervise the contractor.

## **Design/Construct Firms**

A common trend in industrial construction, particularly for large projects, is to engage the services of a design/construct firm. By integrating design and construction management in a single organization, many of the conflicts between designers and constructors might be avoided. In particular, designs will be closely scrutinized for their constructibility. However, an owner engaging a design/construct firm must insure that the quality of the constructed facility is not sacrificed by the desire to reduce the time or the cost for completing the project. Also, it is difficult to make use of competitive bidding in this type of design/construct process. As a result, owners must be relatively sophisticated in negotiating realistic and cost-effective construction contracts.

One of the most obvious advantages of the integrated design/construct process is the use of *phased construction* for a large project. In this process, the project is divided up into several phases, each of which can be designed and constructed in a staggered manner. After the completion of the design of the first phase, construction can begin without waiting for the completion of the design of the second phase, etc. If proper coordination is exercised, the total project duration can be greatly reduced. Another advantage is to exploit the possibility of using the *turnkey* approach whereby an owner can delegate all responsibility to the design/construct firm which will deliver to the owner a completed facility that meets the performance specifications at the specified price.

## **Professional Construction Managers**

In recent years, a new breed of construction managers (CM) offers professional services from the inception to the completion of a construction project. These construction managers mostly come from the ranks of A/E firms or general contractors who may or may not retain dual roles in the service of the owners. In any case, the owner can rely on the service of a single prime professional to manage the entire process of a construction project. However, like the A/E firms of several decades ago, the construction managers are appreciated by some owners but not by others. Before long, some owners find that the construction managers too may try to protect their own interest instead of that of the owners when the stakes are high.

It should be obvious to all involved in the construction process that the party which is required to take higher risk demands larger rewards. If an owner wants to engage an A/E firm on the basis of low fees instead of established qualifications, it often gets what it deserves; or if the owner wants the general contractor to bear the cost of uncertainties in construction such as foundation conditions, the contract price will be higher even if competitive bidding is used in reaching a contractual agreement. Without mutual respect and trust, an owner cannot expect that construction managers can produce better results than other professionals. Hence, an owner must understand its own responsibility and the risk it wishes to assign to itself and to other participants in the process.

## **Operation and Maintenance Managers**

Although many owners keep a permanent staff for the operation and maintenance of constructed facilities, others may prefer to contract such tasks to professional managers. Understandably, it is

common to find in-house staff for operation and maintenance in specialized industrial plants and infrastructure facilities, and the use of outside managers under contracts for the operation and maintenance of rental properties such as apartments and office buildings. However, there are exceptions to these common practices. For example, maintenance of public roadways can be contracted to private firms. In any case, managers can provide a spectrum of operation and maintenance services for a specified time period in accordance to the terms of contractual agreements. Thus, the owners can be spared the provision of in-house expertise to operate and maintain the facilities.

## Facilities Management

As a logical extension for obtaining the best services throughout the project life cycle of a constructed facility, some owners and developers are receptive to adding strategic planning at the beginning and facility maintenance as a follow-up to reduce space-related costs in their real estate holdings. Consequently, some architectural/engineering firms and construction management firms with computer-based expertise, together with interior design firms, are offering such front-end and follow-up services in addition to the more traditional services in design and construction. This spectrum of services is described in *Engineering News-Record* (now *ENR*) as follows: [\[2\]](#)

Facilities management is the discipline of planning, designing, constructing and managing space -- in every type of structure from office buildings to process plants. It involves developing corporate facilities policy, long-range forecasts, real estate, space inventories, projects (through design, construction and renovation), building operation and maintenance plans and furniture and equipment inventories.

A common denominator of all firms entering into these new services is that they all have strong computer capabilities and heavy computer investments. In addition to the use of computers for aiding design and monitoring construction, the service includes the compilation of a computer record of building plans that can be turned over at the end of construction to the facilities management group of the owner. A computer data base of facilities information makes it possible for planners in the owner's organization to obtain overview information for long range space forecasts, while the line managers can use as-built information such as lease/tenant records, utility costs, etc. for day-to-day operations.

[Back to top](#)

## 1.5 Construction Contractors

Builders who supervise the execution of construction projects are traditionally referred to as *contractors*, or more appropriately called *constructors*. The *general contractor* coordinates various tasks for a project while the *specialty contractors* such as mechanical or electrical contractors perform the work in their specialties. Material and equipment suppliers often act as *installation contractors*; they play a significant role in a construction project since the conditions of delivery of materials and equipment affect the quality, cost, and timely completion of the project. It is essential to understand the operation of these contractors in order to deal with them effectively.

### General Contractors

The function of a general contractor is to coordinate all tasks in a construction project. Unless the owner performs this function or engages a professional construction manager to do so, a good general contractor who has worked with a team of superintendents, specialty contractors or subcontractors together for a number of projects in the past can be most effective in inspiring loyalty and cooperation.

The general contractor is also knowledgeable about the labor force employed in construction. The labor force may or may not be unionized depending on the size and location of the projects. In some projects, no member of the work force belongs to a labor union; in other cases, both union and non-union craftsmen work together in what is called an open shop, or all craftsmen must be affiliated with labor unions in a closed shop. Since labor unions provide hiring halls staffed with skilled journeyman who have gone through apprentice programs for the projects as well as serving as collective bargain units, an experienced general contractor will make good use of the benefits and avoid the pitfalls in dealing with organized labor.

## **Specialty Contractors**

Specialty contractors include mechanical, electrical, foundation, excavation, and demolition contractors among others. They usually serve as subcontractors to the general contractor of a project. In some cases, legal statutes may require an owner to deal with various specialty contractors directly. In the State of New York, for example, specialty contractors, such as mechanical and electrical contractors, are not subjected to the supervision of the general contractor of a construction project and must be given separate prime contracts on public works. With the exception of such special cases, an owner will hold the general contractor responsible for negotiating and fulfilling the contractual agreements with the subcontractors.

## **Material and Equipment Suppliers**

Major material suppliers include specialty contractors in structural steel fabrication and erection, sheet metal, ready mixed concrete delivery, reinforcing steel bar detailers, roofing, glazing etc. Major equipment suppliers for industrial construction include manufacturers of generators, boilers and piping and other equipment. Many suppliers handle on-site installation to insure that the requirements and contractual specifications are met. As more and larger structural units are prefabricated off-site, the distribution between specialty contractors and material suppliers becomes even less obvious.

[Back to top](#)

# **1.6 Financing of Constructed Facilities**

A major construction project requires an enormous amount of capital that is often supplied by lenders who want to be assured that the project will offer a fair return on the investment. The direct costs associated with a major construction project may be broadly classified into two categories: (1) the construction expenses paid to the general contractor for erecting the facility on site and (2) the expenses for land acquisition, legal fees, architect/engineer fees, construction management fees, interest on construction loans and the opportunity cost of carrying empty space in the facility until it is fully occupied. The direct construction costs in the first category represent approximately 60 to 80 percent of the total costs in most construction projects. Since the costs of construction are ultimately borne by the owner, careful financial planning for the facility must be made prior to construction.

## **Construction Financing**

Construction loans to contractors are usually provided by banks or savings and loan associations for construction financing. Upon the completion of the facility, construction loans will be terminated and the post-construction facility financing will be arranged by the owner.

Construction loans provided for different types of construction vary. In the case of residential housing,

construction loans and long-term mortgages can be obtained from savings and loans associations or commercial banks. For institutional and commercial buildings, construction loans are usually obtained from commercial banks. Since the value of specialized industrial buildings as collateral for loans is limited, construction loans in this domain are rare, and construction financing can be done from the pool of general corporate funds. For infrastructure construction owned by government, the property cannot be used as security for a private loan, but there are many possible ways to finance the construction, such as general appropriation from taxation or special bonds issued for the project.

Traditionally, banks serve as construction lenders in a three-party agreement among the contractor, the owner and the bank. The stipulated loan will be paid to the contractor on an agreed schedule upon the verification of completion of various portions of the project. Generally, a payment request together with a standard progress report will be submitted each month by the contractor to the owner which in turn submits a draw request to the bank. Provided that the work to date has been performed satisfactorily, the disbursement is made on that basis during the construction period. Under such circumstances, the bank has been primarily concerned with the completion of the facility on time and within the budget. The economic life of the facility after its completion is not a concern because of the transfer of risk to the owner or an institutional lender.

## Facility Financing

Many private corporations maintain a pool of general funds resulting from retained earnings and long-term borrowing on the strength of corporate assets, which can be used for facility financing. Similarly, for public agencies, the long-term funding may be obtained from the commitment of general tax revenues from the federal, state and/or local governments. Both private corporations and public agencies may issue special bonds for the constructed facilities which may obtain lower interest rates than other forms of borrowing. Short-term borrowing may also be used for bridging the gaps in long-term financing. Some corporate bonds are convertible to stocks under circumstances specified in the bond agreement. For public facilities, the assessment of user fees to repay the bond funds merits consideration for certain types of facilities such as toll roads and sewage treatment plants. [3] The use of mortgages is primarily confined to rental properties such as apartments and office buildings.

Because of the sudden surge of interest rates in the late 1970's, many financial institutions offer, in addition to the traditional fixed rate long-term mortgage commitments, other arrangements such as a combination of debt and a percentage of ownership in exchange for a long-term mortgage or the use of adjustable rate mortgages. In some cases, the construction loan may be granted on an open-ended basis without a long-term financing commitment. For example, the plan might be issued for the construction period with an option to extend it for a period of up to three years in order to give the owner more time to seek alternative long-term financing on the completed facility. The bank will be drawn into situations involving financial risk if it chooses to be a lender without long-term guarantees.

For international projects, the currency used for financing agreements becomes important. If financial agreements are written in terms of local currencies, then fluctuations in the currency exchange rate can significantly affect the cost and ultimately profit of a project. In some cases, payments might also be made in particular commodities such as petroleum or the output from the facility itself. Again, these arrangements result in greater uncertainty in the financing scheme because the price of these commodities may vary.

[Back to top](#)

## 1.7 Legal and Regulatory Requirements

The owners of facilities naturally want legal protection for all the activities involved in the construction. It is equally obvious that they should seek competent legal advice. However, there are certain principles that should be recognized by owners in order to avoid unnecessary pitfalls.

## **Legal Responsibilities**

Activities in construction often involve risks, both physical and financial. An owner generally tries to shift the risks to other parties to the degree possible when entering into contractual agreements with them. However, such action is not without cost or risk. For example, a contractor who is assigned the risks may either ask for a higher contract price to compensate for the higher risks, or end up in non-performance or bankruptcy as an act of desperation. Such consequences can be avoided if the owner is reasonable in risk allocation. When risks are allocated to different parties, the owner must understand the implications and spell them out clearly. Sometimes there are statutory limitations on the allocation of liabilities among various groups, such as prohibition against the allocation of negligence in design to the contractor. An owner must realize its superior power in bargaining and hence the responsibilities associated with this power in making contractual agreements.

## **Mitigation of Conflicts**

It is important for the owner to use legal counselors as advisors to mitigate conflicts before they happen rather than to wield conflicts as weapons against other parties. There are enough problems in design and construction due to uncertainty rather than bad intentions. The owner should recognize the more enlightened approaches for mitigating conflicts, such as using owner-controlled *wrap-up* insurance which will provide protection for all parties involved in the construction process for unforeseen risks, or using arbitration, mediation and other extra-judicial solutions for disputes among various parties. However, these compromise solutions are not without pitfalls and should be adopted only on the merit of individual cases.

## **Government Regulation**

To protect public safety and welfare, legislatures and various government agencies periodically issue regulations which influence the construction process, the operation of constructed facilities, and their ultimate disposal. For example, building codes promulgated by local authorities have provided guidelines for design and construction practices for a very long time. Since the 1970's, many federal regulations that are related directly or indirectly to construction have been established in the United States. Among them are safety standards for workers issued by the Occupational Health and Safety Administration, environmental standards on pollutants and toxic wastes issued by the Environmental Protection Agency, and design and operation procedures for nuclear power plants issued by the Nuclear Regulatory Commission.

Owners must be aware of the impacts of these regulations on the costs and durations of various types of construction projects as well as possibilities of litigation due to various contentions. For example, owners acquiring sites for new construction may be strictly liable for any hazardous wastes already on the site or removed from the site under the U.S. Comprehensive Environmental Response Compensation and Liability (CERCLA) Act of 1980. For large scale projects involving new technologies, the construction costs often escalate with the uncertainty associated with such restrictions.

[Back to top](#)

# **1.8 The Changing Environment of the Construction Industry**



The construction industry is a conglomeration of diverse fields and participants that have been loosely lumped together as a sector of the economy. The construction industry plays a central role in national welfare, including the development of residential housing, office buildings and industrial plants, and the restoration of the nation's infrastructure and other public facilities. The importance of the construction industry lies in the function of its products which provide the foundation for industrial production, and its impacts on the national economy cannot be measured by the value of its output or the number of persons employed in its activities alone.

To be more specific, construction refers to all types of activities usually associated with the erection and repair of immobile facilities. Contract construction consists of a large number of firms that perform construction work for others, and is estimated to be approximately 85% of all construction activities. The remaining 15% of construction is performed by owners of the facilities, and is referred to as *force-account* construction. Although the number of contractors in the United States exceeds a million, over 60% of all contractor construction is performed by the top 400 contractors. The value of new construction in the United States (expressed in constant dollars) and the value of construction as a percentage of the gross national products from 1950 to 1985 are shown in Figures 1-6 and 1-7. It can be seen that construction is a significant factor in the Gross National Product although its importance has been declining in recent years. [4] Not to be ignored is the fact that as the nation's constructed facilities become older, the total expenditure on rehabilitation and maintenance may increase relative to the value of new construction.

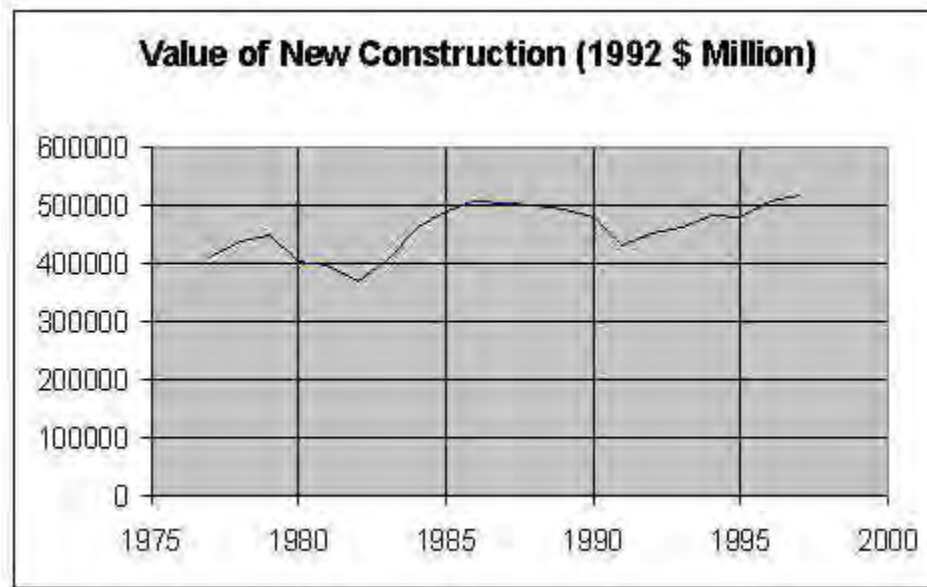

**Figure 1-6:** Value of New Construction in the United States, 1975-1995



**Figure 1-7:** Construction as Percentage of Gross Domestic Product in the United States, 1975-1995

Owners who pay close attention to the peculiar characteristics of the construction industry and its changing operating environment will be able to take advantage of the favorable conditions and to avoid the pitfalls. Several factors are particularly noteworthy because of their significant impacts on the quality, cost and time of construction.

## New Technologies

In recent years, technological innovation in design, materials and construction methods have resulted in significant changes in construction costs. Computer-aids have improved capabilities for generating quality designs as well as reducing the time required to produce alternative designs. New materials not only have enhanced the quality of construction but also have shortened the time for shop fabrication and field erection. Construction methods have gone through various stages of mechanization and automation, including the latest development of construction robotics.

The most dramatic new technology applied to construction has been the Internet and its private, corporate Intranet versions. The Internet is widely used as a means to foster collaboration among professionals on a project, to communicate for bids and results, and to procure necessary goods and services. Real time video from specific construction sites is widely used to illustrate construction progress to interested parties. The result has been more effective collaboration, communication and procurement.

The effects of many new technologies on construction costs have been mixed because of the high development costs for new technologies. However, it is unmistakable that design professionals and construction contractors who have not adapted to changing technologies have been forced out of the mainstream of design and construction activities. Ultimately, construction quality and cost can be improved with the adoption of new technologies which are proved to be efficient from both the viewpoints of performance and economy.

## Labor Productivity

The term *productivity* is generally defined as a ratio of the production output volume to the input volume of resources. Since both output and input can be quantified in a number of ways, there is no single measure of productivity that is universally applicable, particularly in the construction industry where the products are often unique and there is no standard for specifying the levels for aggregation of data. However, since labor constitutes a large part of the cost of construction, labor productivity in terms of output volume (constant dollar value or functional units) per person-hour is a useful measure. Labor productivity measured in this way does not necessarily indicate the efficiency of labor alone but rather measures the combined effects of labor, equipment and other factors contributing to the output.

While aggregate construction industry productivity is important as a measure of national economy, owners are more concerned about the labor productivity of basic units of work produced by various crafts on site. Thus, an owner can compare the labor performance at different geographic locations, under different working conditions, and for different types and sizes of projects.

Construction costs usually run parallel to material prices and labor wages. Actually, over the years, labor productivity has increased in some traditional types of construction and thus provides a leveling or compensating effect when hourly rates for labor increase faster than other costs in construction. However, labor productivity has been stagnant or even declined in unconventional or large scale projects.

## **Public Scrutiny**

Under the present litigious climate in the United States, the public is increasingly vocal in the scrutiny of construction project activities. Sometimes it may result in considerable difficulty in siting new facilities as well as additional expenses during the construction process itself. Owners must be prepared to manage such crises before they get out of control.

Figure 1-8 can serve to indicate public attitudes towards the siting of new facilities. It represents the cumulative percentage of individuals who would be willing to accept a new industrial facility at various distances from their homes. For example, over fifty percent of the people surveyed would accept a ten-story office building within five miles of their home, but only twenty-five percent would accept a large factory or coal fired power plant at a similar distance. An even lower percentage would accept a hazardous waste disposal site or a nuclear power plant. Even at a distance of one hundred miles, a significant fraction of the public would be unwilling to accept hazardous waste facilities or nuclear power plants.

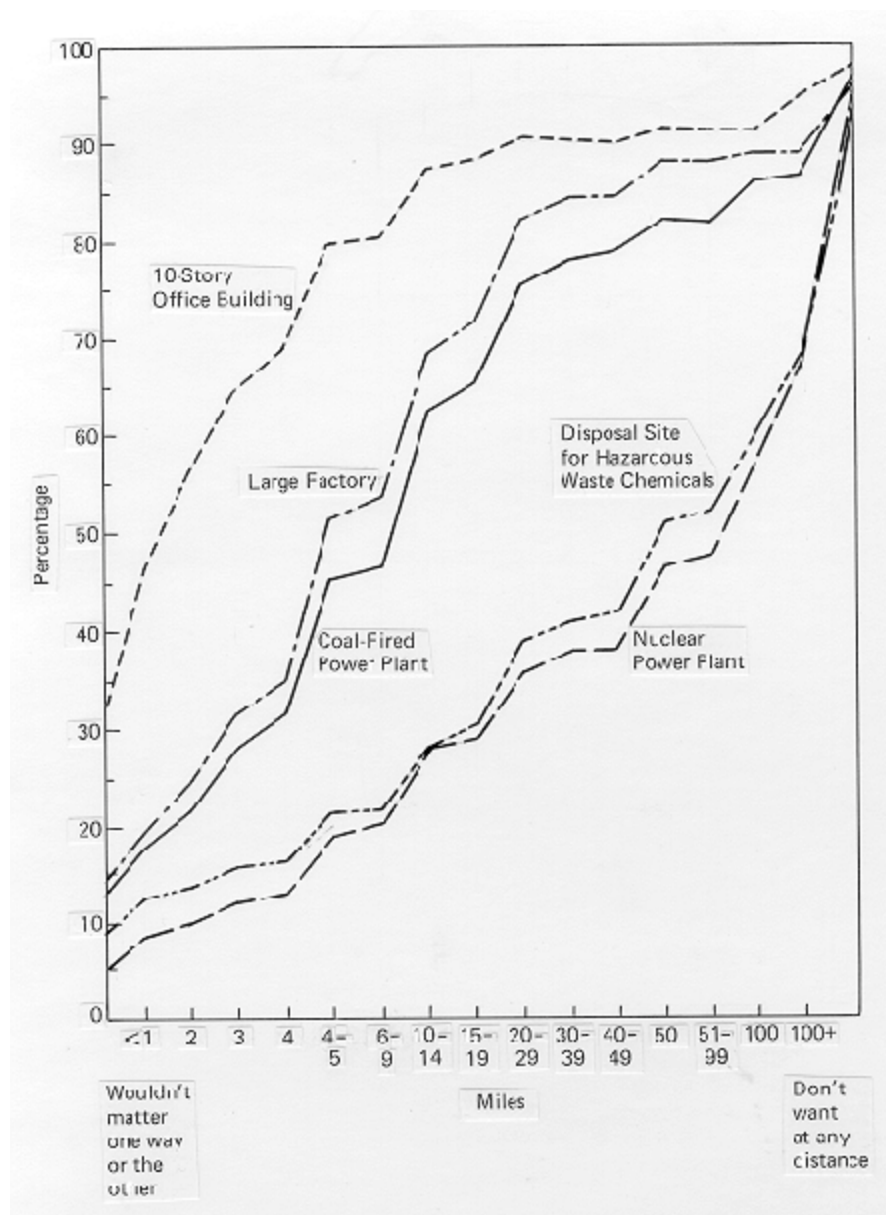

**Figure 1-8:** Public Acceptance Towards New Facilities (Reprinted from *Environmental Quality* - 1980, the Eleventh Annual Report of the Council on Environmental Quality, U.S. Government Printing Office, Washington, DC, December 1980.)

This objection to new facilities is a widespread public attitude, representing considerable skepticism about the external benefits and costs which new facilities will impose. It is this public attitude which is likely to make public scrutiny and regulation a continuing concern for the construction industry.

### International Competition

A final trend which deserves note is the increasing level of international competition in the construction industry. Owners are likely to find non-traditional firms bidding for construction work, particularly on large projects. Separate bids from numerous European, North American, and Asian construction firms are not unusual. In the United States, overseas firms are becoming increasingly visible and important. In

this environment of heightened competition, good project management and improved productivity are more and more important.

A bidding competition for a major new offshore drilling platform illustrates the competitive environment in construction. As described in the Wall Street Journal: [\[5\]](#)

Through most of the postwar years, the nation's biggest builders of offshore oil platforms enjoyed an unusually cozy relationship with the Big Oil Companies they served. Their top officials developed personal friendships with oil executives, entertained them at opulent hunting camps- and won contracts to build nearly every major offshore oil platform in the world....But this summer, the good-old boy network fell apart. Shell [Oil Co.] awarded the main contract for [a new] platform - taller than Chicago's Sears Tower, four times heavier than the Brooklyn Bridge - to a tiny upstart.

The winning bidder arranged overseas fabrication of the rig, kept overhead costs low, and proposed a novel assembly procedure by which construction equipment was mounted on completed sections of the platform in order to speed the completion of the entire structure. The result was lower costs than those estimated and bid by traditional firms.

Of course, U.S. firms including A/E firms, contractors and construction managers are also competing in foreign countries. Their success or failure in the international arena may also affect their capacities and vitality to provide services in the domestic U.S. market.

## **Contractor Financed Projects**

Increasingly, some owners look to contractors or joint ventures as a resource to design, to build and to finance a constructed facility. For example, a utility company may seek a consortium consisting of a design/construct firm and a financial investment firm to assume total liability during construction and thereby eliminate the risks of cost escalation to ratepayers, stockholders and the management. On the other hand, a local sanitation district may seek such a consortium to provide private ownership for a proposed new sewage treatment plant. In the former case, the owner may take over the completed facility and service the debt on construction through long-term financing arrangements; in the latter case, the private owner may operate the completed facility and recover its investment through user fees. The activities of joint ventures among design, construction and investment firms are sometimes referred to as *financial engineering*.

This type of joint venture has become more important in the international construction market where aggressive contractors often win contracts by offering a more attractive financing package rather than superior technology. With a deepening shadow of international debts in recent years, many developing countries are not in a position to undertake any new project without contractor-backed financing. Thus, the contractors or joint ventures in overseas projects are forced into very risky positions if they intend to stay in the competition.

## **Lean Construction**

"Lean manufacturing" had a revolutionary effect on many industries, especially automotive assembly companies. Characteristics of this approach include:

- Improvement in quality and reduction of waste everywhere. Rather than increasing costs, reducing defects and waste proved to improve quality and reduce costs.

- Empowering workers to be responsible for satisfying customer needs. In construction, for example, craftsman should make sure their work satisfied the design intent.
- Continuous improvement of processes involving the entire workforce.

Lean construction is intended to spread these practices within the construction industry. Of course, well managed construction projects already have many aspects of lean construction. For example, just-in-time delivery of materials is commonplace to avoid the waste of large inventory stockpiles. Green building projects attempt to re-use or recycle all construction wastes. But the systematic attention to continuous improvement and zero accidents and defects is new. [Back to top](#)

## 1.9 The Role of Project Managers

In the project life cycle, the most influential factors affecting the outcome of the project often reside at the early stages. At this point, decisions should be based on competent economic evaluation with due consideration for adequate financing, the prevalent social and regulatory environment, and technological considerations. Architects and engineers might specialize in planning, in construction field management, or in operation, but as project managers, they must have some familiarity with all such aspects in order to understand properly their role and be able to make competent decisions.

Since the 1970's, many large-scale projects have run into serious problems of management, such as cost overruns and long schedule delays. Actually, the management of *megaprojects* or *superprojects* is not a practice peculiar to our time. Witness the construction of transcontinental railroads in the Civil War era and the construction of the Panama Canal at the turn of this century. Although the megaprojects of this generation may appear in greater frequency and present a new set of challenge, the problems are organizational rather than technical. As noted by Hardy Cross: [\[6\]](#)

It is customary to think of engineering as a part of a trilogy, pure science, applied science and engineering. It needs emphasis that this trilogy is only one of a triad of trilogies into which engineering fits. This first is pure science, applied science and engineering; the second is economic theory, finance and engineering; and the third is social relations, industrial relations and engineering. Many engineering problems are as closely allied to social problems as they are to pure science.

As engineers advance professionally, they often spend as much or more time on planning, management and other economic or social problems as on the traditional engineering design and analysis problems which form the core of most educational programs. It is upon the ability of engineers to tackle all such problems that their performance will ultimately be judged.

The greatest stumbling block to effective management in construction is the inertia and historic divisions among planners, designers and constructors. While technical competence in design and innovation remains the foundation of engineering practice, the social, economic and organizational factors that are pervasive in influencing the success and failure of construction projects must also be dealt with effectively by design and construction organizations. Of course, engineers are not expected to know every detail of management techniques, but they must be knowledgeable enough to anticipate the problems of management so that they can work harmoniously with professionals in related fields to overcome the inertia and historic divisions.

Paradoxically, engineers who are creative in engineering design are often innovative in planning and management since both types of activities involve problem solving. In fact, they can reinforce each other if both are included in the education process, provided that creativity and innovation instead of routine

practice are emphasized. A project manager who is well educated in the *fundamental principles* of engineering design and management can usefully apply such principles once he or she has acquired basic understanding of a new *application area*. A project manager who has been trained by rote learning for a specific type of project may merely gain one year of experience repeated twenty times even if he or she has been in the field for twenty years. A broadly educated project manager can reasonably hope to become a leader in the profession; a narrowly trained project manager is often relegated to the role of his or her first job level permanently.

The owners have much at stake in selecting a competent project manager and in providing her or him with the authority to assume responsibility at various stages of the project regardless of the types of contractual agreements for implementing the project. Of course, the project manager must also possess the leadership quality and the ability to handle effectively intricate interpersonal relationships within an organization. The ultimate test of the education and experience of a project manager for construction lies in her or his ability to apply fundamental principles to solving problems in the new and unfamiliar situations which have become the hallmarks of the changing environment in the construction industry.

[Back to top](#)

## 1.10 References

1. Au, T. and C. Hendrickson, "Education in Engineering Planning and Management," *Proceedings of the ASCE Conference on Civil Engineering Education*, Columbus, Ohio, 1985.
2. Barrie, D.S. (editor), *Directions in Managing Construction*, John Wiley and Sons, New York, 1981.
3. Lean Construction Institute, <http://www.leanconstruction.org/>
4. Bonny, J.B. and J.P. Frein, *Handbook of Construction Management and Organization*, 2nd Edition, Van Nostrand Reinhold Co., New York, 1980.
5. Hasagawa, Fumio et.al., "Built by Japan," John Wiley & Sons, 1988.
6. Lang, J.E. and D.Q. Mills, *The Construction Industry*, Lexington Books, Lexington, MA, 1979.
7. Walker, N., E.N. Walker and T.K. Rohdenburg, *Legal Pitfalls in Architecture, Engineering and Building Construction*, 2nd Edition, McGraw-Hill Book Co., New York, 1979.

[Back to top](#)

## 1.11 Footnotes

1. The Business Roundtable, *More Construction for the Money*, Summary Report of the Construction Industry Cost Effectiveness Project, January 1983, p. 11. [Back](#)
2. "Hot New Market Lures A-E Players to Cutting Edges," *Engineering News-Record*, April 4, 1985, pp. 30-37. [Back](#)
3. See Hendrickson, C., "Financing Civil Works with User Fees," *Civil Engineering*, Vol. 53, No. 2, February 1983, pp. 71-72. [Back](#)
4. The graph is derived from data in "Value of New Construction Put in Place, 1960-1983", *Statistical Abstract of the United States*, 105th Edition, U.S. Department of Commerce, Bureau of Census, 1985, pp. 722-723, as well as the information in earlier editions. [Back](#)
5. See Petzinger, Thomas Jr., "Upstart's Winning Bid for Offshore Platform Stuns its Older Rivals," *Wall Street Journal*, p. 1, c. 6, Nov. 20, 1985. [Back](#)
6. See H. Cross, *Engineers and Ivory Towers*, McGraw-Hill Book Co., Inc., New York, 1952. [Back](#)

[Table of Contents](#) | [Next Chapter](#)



<a href="#">Go Up to Table of Contents</a>	
<a href="#">Go To Chapter 1 (The Owners' Perspective)</a>	<a href="#">Go To Chapter 3 (The Design and Construction Process)</a>
<i>Organizing for Project Management</i>	
<a href="#">What is Project Management?</a>	
<a href="#">Trends in Modern Management</a>	
<a href="#">Strategic Planning and Project Programming</a>	
<a href="#">Effects of Project Risks on Organization</a>	
<a href="#">Organization of Project Participants</a>	
<a href="#">Traditional Designer-Constructor Sequence</a>	
<a href="#">Professional Construction Management</a>	
<a href="#">Owner-Builder Operation</a>	
<a href="#">Turnkey Operation</a>	
<a href="#">Leadership and Motivation for the Project Team</a>	
<a href="#">Interpersonal Behavior in Project Organizations</a>	
<a href="#">Perceptions of Owners and Contractors</a>	
<a href="#">References</a>	
<a href="#">Footnotes</a>	

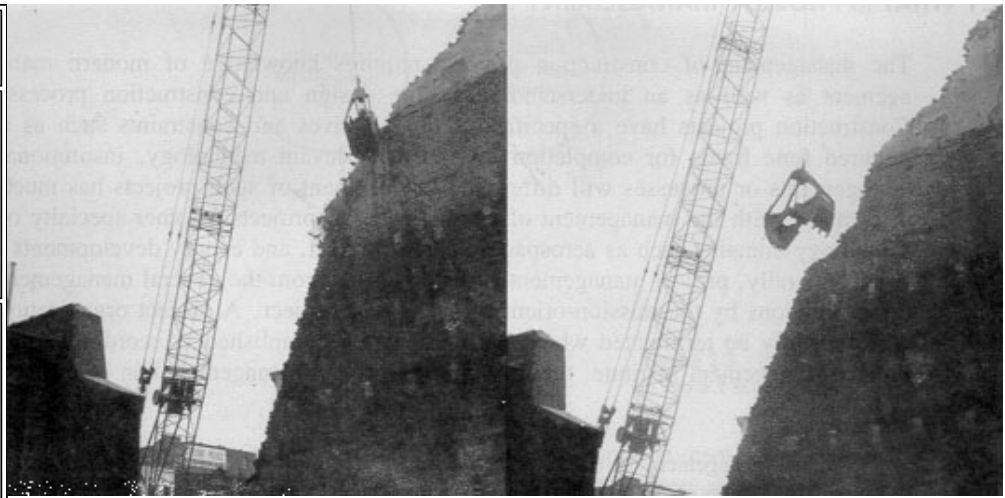

[http://pmbook.ce.cmu.edu/02\\_Organizing\\_For\\_Project\\_Management.html](http://pmbook.ce.cmu.edu/02_Organizing_For_Project_Management.html)

## 2. Organizing for Project Management

### 2.1 What is Project Management?

The management of construction projects requires knowledge of modern management as well as an understanding of the design and construction process. Construction projects have a specific set of objectives and constraints such as a required time frame for completion. While the relevant technology, institutional arrangements or processes will differ, the management of such projects has much in common with the management of similar types of projects in other specialty or technology domains such as aerospace, pharmaceutical and energy developments.

Generally, project management is distinguished from the general management of corporations by the mission-oriented nature of a project. A project organization will generally be terminated when the mission is accomplished. According to the Project Management Institute, the discipline of project management can be defined as follows: [\[1\]](#)

Project management is the art of directing and coordinating human and material resources throughout the life of a project by using modern management techniques to achieve predetermined objectives of scope, cost, time, quality and participation satisfaction.

By contrast, the general management of business and industrial corporations assumes a broader outlook with greater continuity of operations. Nevertheless, there are sufficient similarities as well as differences between the two so that modern management techniques developed for general management may be adapted for project management.

The basic ingredients for a project management framework [2] may be represented schematically in Figure 2-1. A working knowledge of general management and familiarity with the special knowledge domain related to the project are indispensable. Supporting disciplines such as computer science and decision science may also play an important role. In fact, modern management practices and various special knowledge domains have absorbed various techniques or tools which were once identified only with the supporting disciplines. For example, computer-based information systems and decision support systems are now common-place tools for general management. Similarly, many operations research techniques such as linear programming and network analysis are now widely used in many knowledge or application domains. Hence, the representation in Figure 2-1 reflects only the sources from which the project management framework evolves.

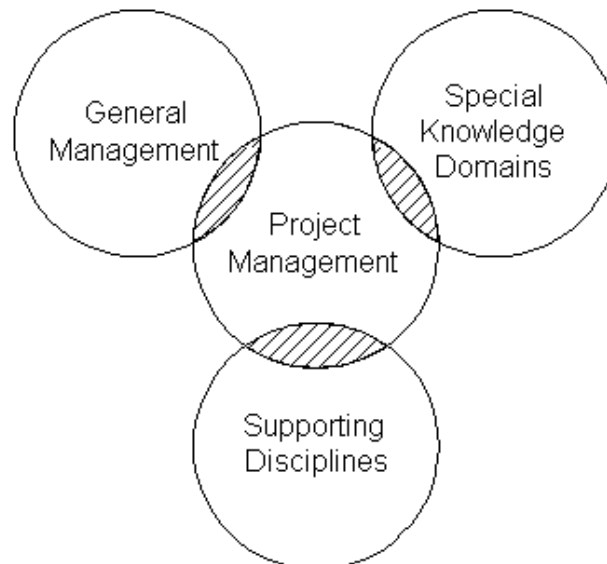

**Figure 2-1:** Basic Ingredients in Project Management

Specifically, project management in construction encompasses a set of objectives which may be accomplished by implementing a series of operations subject to resource constraints. There are potential conflicts between the stated objectives with regard to scope, cost, time and quality, and the constraints imposed on human material and financial resources. These conflicts should be resolved at the onset of a project by making the necessary tradeoffs or creating new alternatives. Subsequently, the functions of project management for construction generally include the following:

1. Specification of project objectives and plans including delineation of scope, budgeting, scheduling, setting performance requirements, and selecting project participants.
2. Maximization of efficient resource utilization through procurement of labor, materials and equipment according to the prescribed schedule and plan.
3. Implementation of various operations through proper coordination and control of planning, design, estimating, contracting and construction in the entire process.
4. Development of effective communications and mechanisms for resolving conflicts among the various participants.

The Project Management Institute focuses on nine distinct areas requiring project manager knowledge and attention:

1. Project integration management to ensure that the various project elements are effectively coordinated.
2. Project scope management to ensure that all the work required (and only the required work) is included.
3. Project time management to provide an effective project schedule.
4. Project cost management to identify needed resources and maintain budget control.
5. Project quality management to ensure functional requirements are met.
6. Project human resource management to development and effectively employ project personnel.
7. Project communications management to ensure effective internal and external communications.
8. Project risk management to analyze and mitigate potential risks.
9. Project procurement management to obtain necessary resources from external sources.

These nine areas form the basis of the Project Management Institute's certification program for project managers in any industry. [Back to top](#)

## 2.2 Trends in Modern Management

In recent years, major developments in management reflect the acceptance to various degrees of the following elements: (1) the management process approach, (2) the management science and decision support approach, (3) the behavioral science approach for human resource development, and (4) sustainable competitive advantage. These four approaches complement each other in current practice, and provide a useful groundwork for project management.

The management process approach emphasizes the systematic study of management by identifying management functions in an organization and then examining each in detail. There is general agreement regarding the functions of planning, organizing and controlling. A major tenet is that by analyzing management along functional lines, a framework can be constructed into which all new management activities can be placed. Thus, the manager's job is regarded as coordinating a process of interrelated functions, which are neither totally random nor rigidly predetermined, but are dynamic as the process evolves. Another tenet is that management principles can be derived from an intellectual analysis of management functions. By dividing the manager's job into functional components, principles based upon each function can be extracted. Hence, management functions can be organized into a hierarchical structure designed to improve operational efficiency, such as the example of the organization for a manufacturing company shown in Figure 2-2. The basic management functions are performed by all managers, regardless of enterprise, activity or hierarchical levels. Finally, the development of a management philosophy results in helping the manager to establish relationships between human and material resources. The outcome of following an established philosophy of operation helps the manager win the support of the subordinates in achieving organizational objectives.

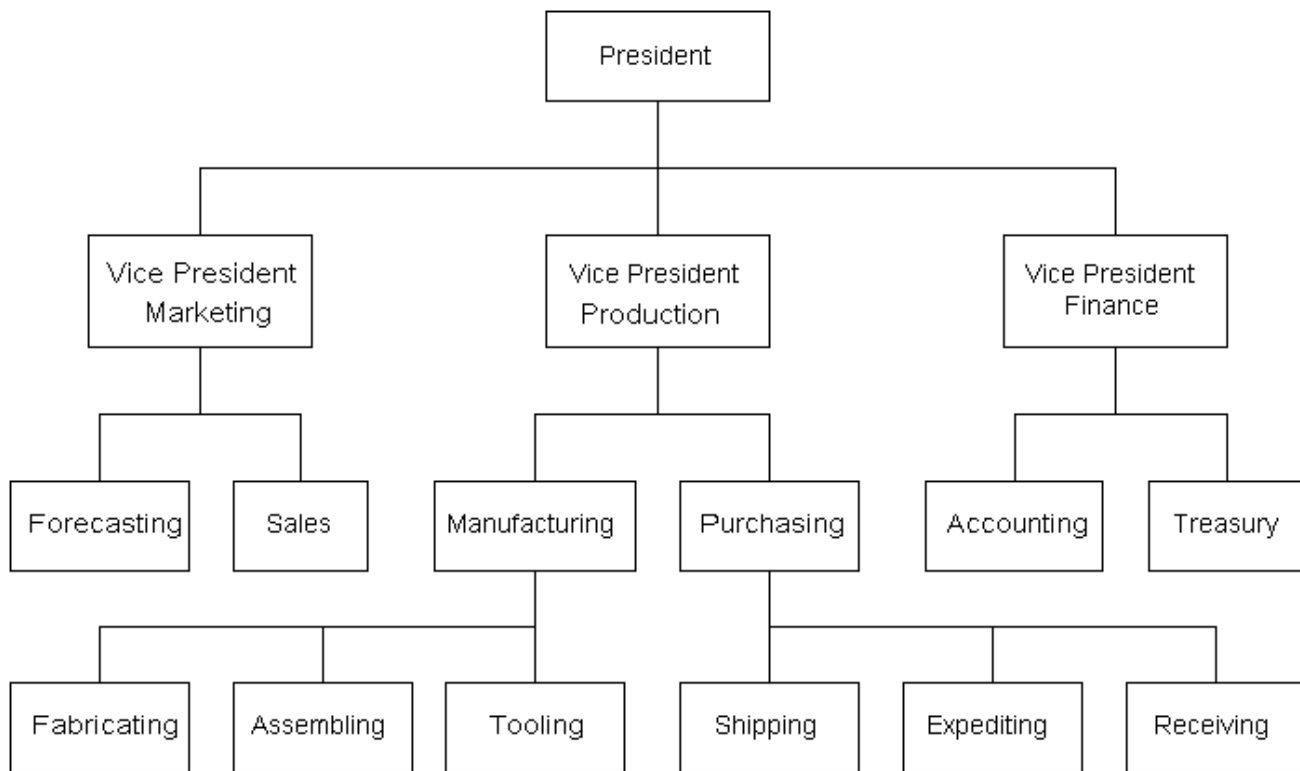

**Figure 2-2:** Illustrative Hierarchical Structure of Management Functions

The management science and decision support approach contributes to the development of a body of quantitative methods designed to aid managers in making complex decisions related to operations and production. In decision support systems, emphasis is placed on providing managers with relevant information. In management science, a great deal of attention is given to defining objectives and constraints, and to constructing mathematical analysis models in solving complex problems of inventory, materials and production control, among others. A topic of major interest in management science is the maximization of profit, or in the absence of a workable model for the operation of the entire system, the suboptimization of the operations of its components. The optimization or suboptimization is often achieved by the use of operations research techniques, such as linear programming, quadratic programming, graph theory, queuing theory and Monte Carlo simulation. In addition to the increasing use of computers accompanied by the development of sophisticated mathematical models and information systems, management science and decision support systems have played an important role by looking more carefully at problem inputs and relationships and by promoting goal formulation and measurement of performance. Artificial intelligence has also begun to be applied to provide decision support systems for solving ill-structured problems in management.

The behavioral science approach for human resource development is important because management entails getting things done through the actions of people. An effective manager must understand the importance of human factors such as needs, drives, motivation, leadership, personality, behavior, and work groups. Within this context, some place more emphasis on interpersonal behavior which focuses on the individual and his/her motivations as a socio-psychological being; others emphasize more group behavior in recognition of the organized enterprise as a social organism, subject to all the attitudes, habits, pressures and conflicts of the cultural environment of people. The major contributions made by the behavioral scientists to the field of management include: (1) the formulation of concepts and explanations about individual and group behavior in the organization, (2) the empirical testing of these concepts methodically in many different experimental and field settings, and (3) the establishment of actual managerial policies and decisions for operation based on the conceptual and methodical frameworks.

Sustainable competitive advantage stems primarily from good management strategy. As Michael Porter of the

Harvard Business School argues:

Strategy is creating fit among a company's activities. The success of a strategy depends on doing many things well - not just a few - and integrating among them. If there is no fit among activities, there is no distinctive strategy and little sustainability.

In this view, successful firms must improve and align the many processes underway to their strategic vision. Strategic positioning in this fashion requires:

- Creating a unique and valuable position.
- Making trade-offs compared to competitors
- Creating a "fit" among a company's activities.

Project managers should be aware of the strategic position of their own organization and the other organizations involved in the project. The project manager faces the difficult task of trying to align the goals and strategies of these various organizations to accomplish the project goals. For example, the owner of an industrial project may define a strategic goal as being first to market with new products. In this case, facilities development must be oriented to fast-track, rapid construction. As another example, a contracting firm may see their strategic advantage in new technologies and emphasize profit opportunities from value engineering (as described in Chapter 3).

[Back to top](#)

## 2.3 Strategic Planning and Project Programming

The programming of capital projects is shaped by the strategic plan of an organization, which is influenced by market demands and resources constraints. The programming process associated with planning and feasibility studies sets the priorities and timing for initiating various projects to meet the overall objectives of the organizations. However, once this decision is made to initiate a project, market pressure may dictate early and timely completion of the facility.

Among various types of construction, the influence of market pressure on the timing of initiating a facility is most obvious in industrial construction. [3] Demand for an industrial product may be short-lived, and if a company does not hit the market first, there may not be demand for its product later. With intensive competition for national and international markets, the trend of industrial construction moves toward shorter project life cycles, particularly in technology intensive industries.

In order to gain time, some owners are willing to forego thorough planning and feasibility study so as to proceed on a project with inadequate definition of the project scope. Invariably, subsequent changes in project scope will increase construction costs; however, profits derived from earlier facility operation often justify the increase in construction costs. Generally, if the owner can derive reasonable profits from the operation of a completed facility, the project is considered a success even if construction costs far exceed the estimate based on an inadequate scope definition. This attitude may be attributed in large part to the uncertainties inherent in construction projects. It is difficult to argue that profits might be even higher if construction costs could be reduced without increasing the project duration. However, some projects, notably some nuclear power plants, are clearly unsuccessful and abandoned before completion, and their demise must be attributed at least in part to inadequate planning and poor feasibility studies.

The owner or facility sponsor holds the key to influence the construction costs of a project because any decision made at the beginning stage of a project life cycle has far greater influence than those made at later stages, as shown schematically in Figure 2-3. Moreover, the design and construction decisions will influence the continuing operating costs and, in many cases, the revenues over the facility lifetime. Therefore, an owner should obtain the expertise of professionals to provide adequate planning and feasibility studies. Many owners do not maintain an in-house engineering and construction management capability, and they should consider the

establishment of an ongoing relationship with outside consultants in order to respond quickly to requests. Even among those owners who maintain engineering and construction divisions, many treat these divisions as reimbursable, independent organizations. Such an arrangement should not discourage their legitimate use as false economies in reimbursable costs from such divisions can indeed be very costly to the overall organization.

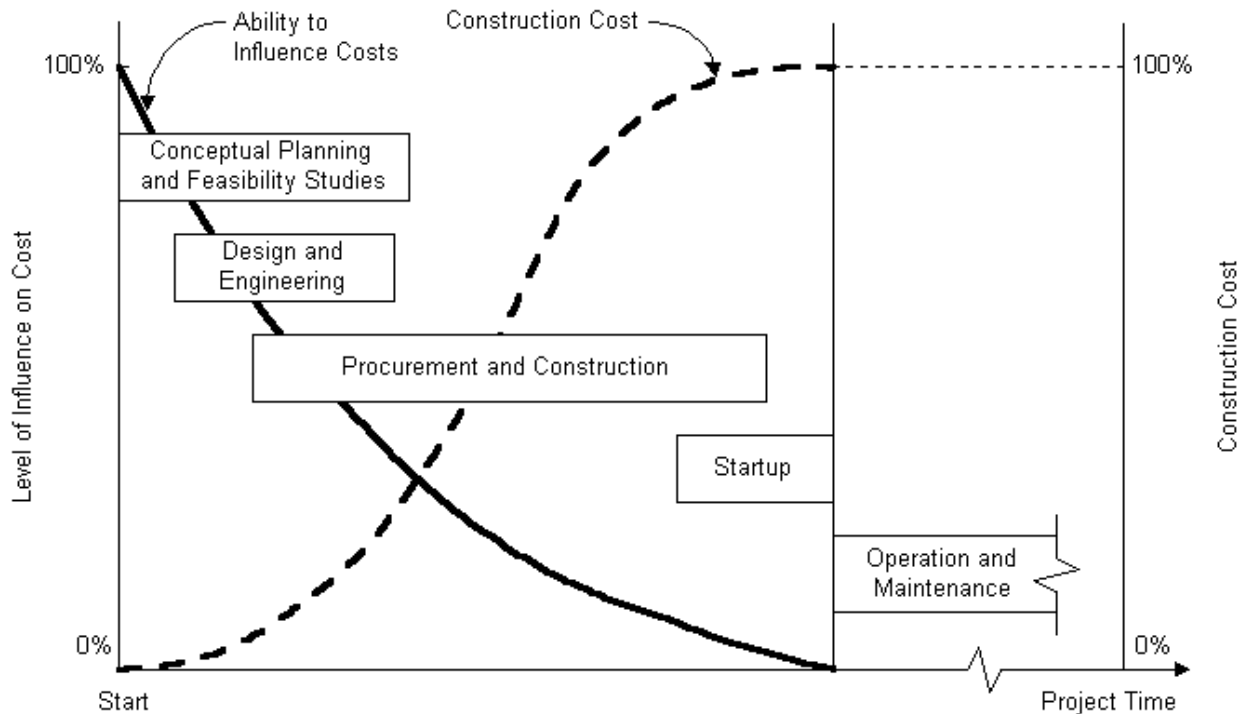

**Figure 2-3:** Ability to Influence Construction Cost Over Time

Finally, the initiation and execution of capital projects places demands on the resources of the owner and the professionals and contractors to be engaged by the owner. For very large projects, it may bid up the price of engineering services as well as the costs of materials and equipment and the contract prices of all types. Consequently, such factors should be taken into consideration in determining the timing of a project.

### Example 2-1: Setting priorities for projects

A department store planned to expand its operation by acquiring 20 acres of land in the southeast of a metropolitan area which consists of well established suburbs for middle income families. An architectural/engineering (A/E) firm was engaged to design a shopping center on the 20-acre plot with the department store as its flagship plus a large number of storefronts for tenants. One year later, the department store owner purchased 2,000 acres of farm land in the northwest outskirts of the same metropolitan area and designated 20 acres of this land for a shopping center. The A/E firm was again engaged to design a shopping center at this new location.

The A/E firm was kept completely in the dark while the assemblage of the 2,000 acres of land in the northwest quietly took place. When the plans and specifications for the southeast shopping center were completed, the owner informed the A/E firm that it would not proceed with the construction of the southeast shopping center for the time being. Instead, the owner urged the A/E firm to produce a new set of similar plans and specifications for the northwest shopping center as soon as possible, even at the sacrifice of cost saving measures. When the plans and specifications for the northwest shopping center were ready, the owner immediately authorized its construction. However, it took

another three years before the southeast shopping center was finally built.

The reason behind the change of plan was that the owner discovered the availability of the farm land in the northwest which could be developed into residential real estate properties for upper middle income families. The immediate construction of the northwest shopping center would make the land development parcels more attractive to home buyers. Thus, the owner was able to recoup enough cash flow in three years to construct the southeast shopping center in addition to financing the construction of the northeast shopping center, as well as the land development in its vicinity.

While the owner did not want the construction cost of the northwest shopping center to run wild, it apparently was satisfied with the cost estimate based on the detailed plans of the southeast shopping center. Thus, the owner had a general idea of what the construction cost of the northwest shopping center would be, and did not wish to wait for a more refined cost estimate until the detailed plans for that center were ready. To the owner, the timeliness of completing the construction of the northwest shopping center was far more important than reducing the construction cost in fulfilling its investment objectives.

### **Example 2-2: Resource Constraints for Mega Projects**

A major problem with mega projects is the severe strain placed on the environment, particularly on the resources in the immediate area of a construction project. "Mega" or "macro" projects involve construction of very large facilities such as the Alaska pipeline constructed in the 1970's or the Panama Canal constructed in the 1900's. The limitations in some or all of the basic elements required for the successful completion of a mega project include:

- engineering design professionals to provide sufficient manpower to complete the design within a reasonable time limit.
- construction supervisors with capacity and experience to direct large projects.
- the number of construction workers with proper skills to do the work.
- the market to supply materials in sufficient quantities and of required quality on time.
- the ability of the local infrastructure to support the large number of workers over an extended period of time, including housing, transportation and other services.

To compound the problem, mega projects are often constructed in remote environments away from major population centers and subject to severe climate conditions. Consequently, special features of each mega project must be evaluated carefully.

[Back to top](#)

## **2.4 Effects of Project Risks on Organization**

The uncertainty in undertaking a construction project comes from many sources and often involves many participants in the project. Since each participant tries to minimize its own risk, the conflicts among various participants can be detrimental to the project. Only the owner has the power to moderate such conflicts as it alone holds the key to risk assignment through proper contractual relations with other participants. Failure to recognize this responsibility by the owner often leads to undesirable results. In recent years, the concept of "risk sharing/risk assignment" contracts has gained acceptance by the federal government. [4] Since this type of contract acknowledges the responsibilities of the owners, the contract prices are expected to be lower than those in which all risks are assigned to contractors.

In approaching the problem of uncertainty, it is important to recognize that incentives must be provided if any of the participants is expected to take a greater risk. The willingness of a participant to accept risks often reflects the professional competence of that participant as well as its propensity to risk. However, society's perception of the potential liabilities of the participant can affect the attitude of risk-taking for all participants. When a claim is

made against one of the participants, it is difficult for the public to know whether a fraud has been committed, or simply that an accident has occurred.

Risks in construction projects may be classified in a number of ways. [5] One form of classification is as follows:

1. Socioeconomic factors
  - Environmental protection
  - Public safety regulation
  - Economic instability
  - Exchange rate fluctuation
2. Organizational relationships
  - Contractual relations
  - Attitudes of participants
  - Communication
3. Technological problems
  - Design assumptions
  - Site conditions
  - Construction procedures
  - Construction occupational safety

The environmental protection movement has contributed to the uncertainty for construction because of the inability to know what will be required and how long it will take to obtain approval from the regulatory agencies. The requirements of continued re-evaluation of problems and the lack of definitive criteria which are practical have also resulted in added costs. Public safety regulations have similar effects, which have been most noticeable in the energy field involving nuclear power plants and coal mining. The situation has created constantly shifting guidelines for engineers, constructors and owners as projects move through the stages of planning to construction. These moving targets add a significant new dimension of uncertainty which can make it virtually impossible to schedule and complete work at budgeted cost. Economic conditions of the past decade have further reinforced the climate of uncertainty with high inflation and interest rates. The deregulation of financial institutions has also generated unanticipated problems related to the financing of construction.

Uncertainty stemming from regulatory agencies, environmental issues and financial aspects of construction should be at least mitigated or ideally eliminated. Owners are keenly interested in achieving some form of breakthrough that will lower the costs of projects and mitigate or eliminate lengthy delays. Such breakthroughs are seldom planned. Generally, they happen when the right conditions exist, such as when innovation is permitted or when a basis for incentive or reward exists. However, there is a long way to go before a true partnership of all parties involved can be forged.

During periods of economic expansion, major capital expenditures are made by industries and bid up the cost of construction. In order to control costs, some owners attempt to use fixed price contracts so that the risks of unforeseen contingencies related to an overheated economy are passed on to contractors. However, contractors will raise their prices to compensate for the additional risks.

The risks related to organizational relationships may appear to be unnecessary but are quite real. Strained relationships may develop between various organizations involved in the design/construct process. When problems occur, discussions often center on responsibilities rather than project needs at a time when the focus should be on solving the problems. Cooperation and communication between the parties are discouraged for fear of the effects of impending litigation. This barrier to communication results from the ill-conceived notion that uncertainties resulting from technological problems can be eliminated by appropriate contract terms. The net result has been an increase in the costs of constructed facilities.

The risks related to technological problems are familiar to the design/construct professions which have some degree of control over this category. However, because of rapid advances in new technologies which present



new problems to designers and constructors, technological risk has become greater in many instances. Certain design assumptions which have served the professions well in the past may become obsolete in dealing with new types of facilities which may have greater complexity or scale or both. Site conditions, particularly subsurface conditions which always present some degree of uncertainty, can create an even greater degree of uncertainty for facilities with heretofore unknown characteristics during operation. Because construction procedures may not have been fully anticipated, the design may have to be modified after construction has begun. An example of facilities which have encountered such uncertainty is the nuclear power plant, and many owners, designers and contractors have suffered for undertaking such projects.

If each of the problems cited above can cause uncertainty, the combination of such problems is often regarded by all parties as being out of control and inherently risky. Thus, the issue of liability has taken on major proportions and has influenced the practices of engineers and constructors, who in turn have influenced the actions of the owners.

Many owners have begun to understand the problems of risks and are seeking to address some of these problems. For example, some owners are turning to those organizations that offer complete capabilities in planning, design, and construction, and tend to avoid breaking the project into major components to be undertaken individually by specialty participants. Proper coordination throughout the project duration and good organizational communication can avoid delays and costs resulting from fragmentation of services, even though the components from various services are eventually integrated.

Attitudes of cooperation can be readily applied to the private sector, but only in special circumstances can they be applied to the public sector. The ability to deal with complex issues is often precluded in the competitive bidding which is usually required in the public sector. The situation becomes more difficult with the proliferation of regulatory requirements and resulting delays in design and construction while awaiting approvals from government officials who do not participate in the risks of the project.

[Back to top](#)

## 2.5 Organization of Project Participants

The top management of the owner sets the overall policy and selects the appropriate organization to take charge of a proposed project. Its policy will dictate how the project life cycle is divided among organizations and which professionals should be engaged. Decisions by the top management of the owner will also influence the organization to be adopted for project management. In general, there are many ways to decompose a project into stages. The most typical ways are:

- Sequential processing whereby the project is divided into separate stages and each stage is carried out successively in sequence.
- Parallel processing whereby the project is divided into independent parts such that all stages are carried out simultaneously.
- Staggered processing whereby the stages may be overlapping, such as the use of phased design-construct procedures for fast track operation.

It should be pointed out that some decompositions may work out better than others, depending on the circumstances. In any case, the prevalence of decomposition makes the subsequent integration particularly important. The critical issues involved in organization for project management are:

- How many organizations are involved?
- What are the relationships among the organizations?
- When are the various organizations brought into the project?

There are two basic approaches to organize for project implementation, even though many variations may exist as a result of different contractual relationships adopted by the owner and builder. These basic approaches are

divided along the following lines:

1. **Separation of organizations.** Numerous organizations serve as consultants or contractors to the owner, with different organizations handling design and construction functions. Typical examples which involve different degrees of separation are:
  - Traditional sequence of design and construction
  - Professional construction management
2. **Integration of organizations.** A single or joint venture consisting of a number of organizations with a single command undertakes both design and construction functions. Two extremes may be cited as examples:
  - Owner-builder operation in which all work will be handled in house by force account.
  - Turnkey operation in which all work is contracted to a vendor which is responsible for delivering the completed project

Since construction projects may be managed by a spectrum of participants in a variety of combinations, the organization for the management of such projects may vary from case to case. On one extreme, each project may be staffed by existing personnel in the functional divisions of the organization on an ad-hoc basis as shown in Figure 2-4 until the project is completed. This arrangement is referred to as the matrix organization as each project manager must negotiate all resources for the project from the existing organizational framework. On the other hand, the organization may consist of a small central functional staff for the exclusive purpose of supporting various projects, each of which has its functional divisions as shown in Figure 2-5. This decentralized set-up is referred to as the project oriented organization as each project manager has autonomy in managing the project. There are many variations of management style between these two extremes, depending on the objectives of the organization and the nature of the construction project. For example, a large chemical company with in-house staff for planning, design and construction of facilities for new product lines will naturally adopt the matrix organization. On the other hand, a construction company whose existence depends entirely on the management of certain types of construction projects may find the project-oriented organization particularly attractive. While organizations may differ, the same basic principles of management structure are applicable to most situations.

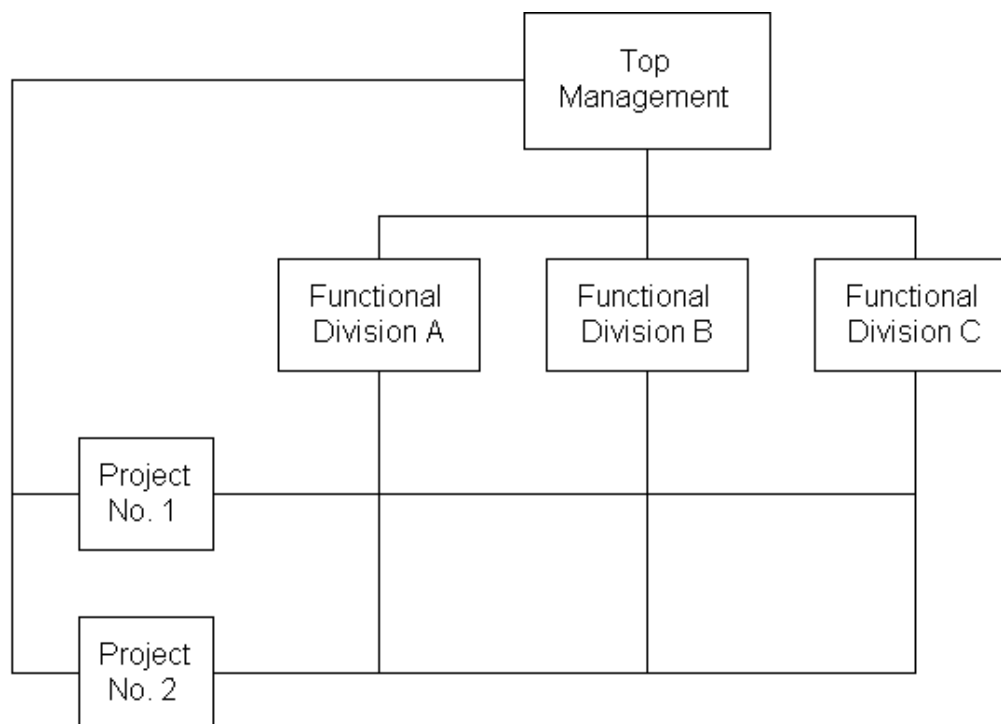

**Figure 2-4:** A Matrix Organization

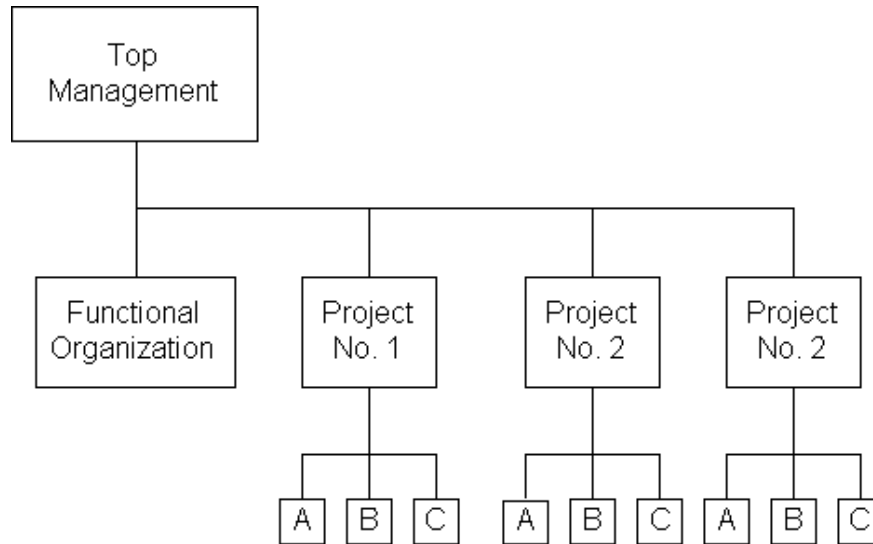
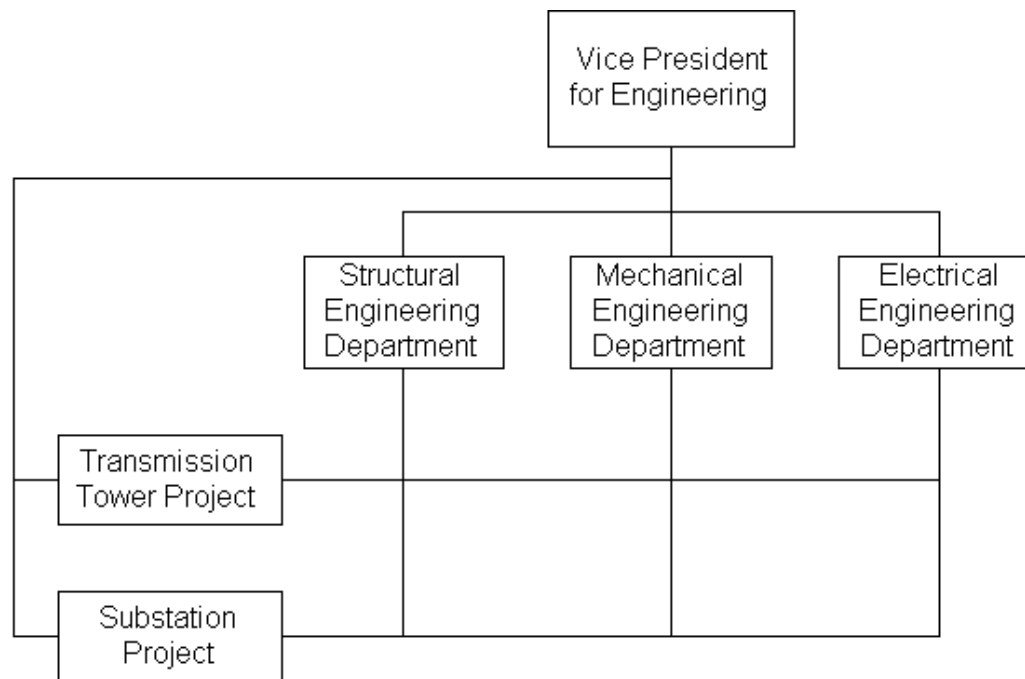

**Figure 2-5:** A Project-Oriented Organization

To illustrate various types of organizations for project management, we shall consider two examples, the first one representing an owner organization while the second one representing the organization of a construction management consultant under the direct supervision of the owner.

### **Example 2-3: Matrix Organization of an Engineering Division**

The Engineering Division of an Electric Power and Light Company has functional departments as shown in Figure 2-6. When small scale projects such as the addition of a transmission tower or a sub-station are authorized, a matrix organization is used to carry out such projects. For example, in the design of a transmission tower, the professional skill of a structural engineer is most important. Consequently, the leader of the project team will be selected from the Structural Engineering Department while the remaining team members are selected from all departments as dictated by the manpower requirements. On the other hand, in the design of a new sub-station, the professional skill of an electrical engineer is most important. Hence, the leader of the project team will be selected from the Electrical Engineering Department.



**Figure 2-6:** The Matrix Organization in an Engineering Division

**Example 2-4: Example of Construction Management Consultant Organization**

When the same Electric Power and Light Company in the previous example decided to build a new nuclear power plant, it engaged a construction management consultant to take charge of the design and construction completely. However, the company also assigned a project team to coordinate with the construction management consultant as shown in Figure 2-7.

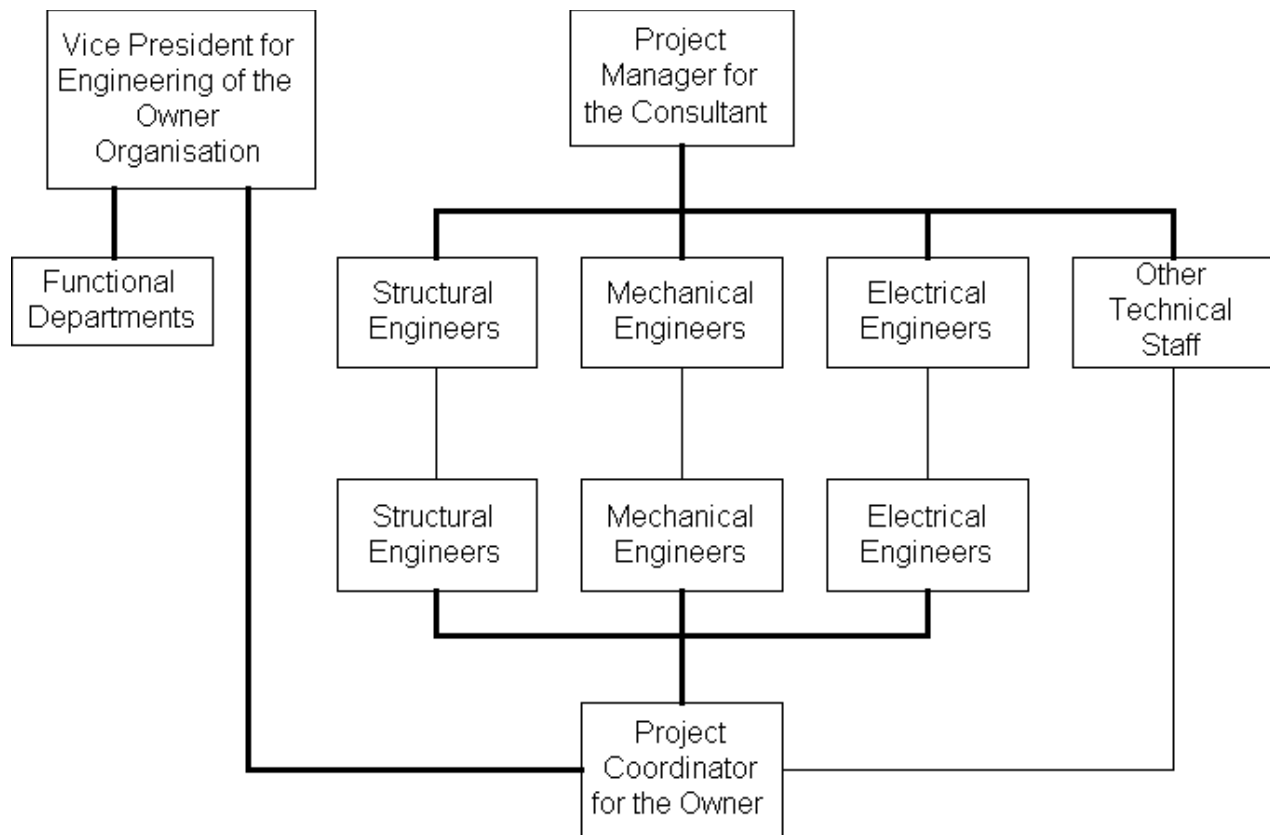

**Figure 2-7:** Coordination between Owner and Consultant

Since the company eventually will operate the power plant upon its completion, it is highly important for its staff to monitor the design and construction of the plant. Such coordination allows the owner not only to assure the quality of construction but also to be familiar with the design to facilitate future operation and maintenance. Note the close direct relationships of various departments of the owner and the consultant. Since the project will last for many years before its completion, the staff members assigned to the project team are not expected to rejoin the Engineering Department but will probably be involved in the future operation of the new plant. Thus, the project team can act independently toward its designated mission.

[Back to top](#)

## 2.6 Traditional Designer-Constructor Sequence

For ordinary projects of moderate size and complexity, the owner often employs a designer (an architectural/engineering firm) which prepares the detailed plans and specifications for the constructor (a general contractor). The designer also acts on behalf of the owner to oversee the project implementation during construction. The general contractor is responsible for the construction itself even though the work may actually be undertaken by a number of specialty subcontractors.

The owner usually negotiates the fee for service with the architectural/engineering (A/E) firm. In addition to the responsibilities of designing the facility, the A/E firm also exercises to some degree supervision of the construction as stipulated by the owner. Traditionally, the A/E firm regards itself as design professionals representing the owner who should not communicate with potential contractors to avoid collusion or conflict of interest. Field inspectors working for an A/E firm usually follow through the implementation of a project after the design is completed and seldom have extensive input in the design itself. Because of the litigation climate in the last two decades, most A/E firms only provide observers rather than inspectors in the field. Even the shop

drawings of fabrication or construction schemes submitted by the contractors for approval are reviewed with a disclaimer of responsibility by the A/E firms.

The owner may select a general constructor either through competitive bidding or through negotiation. Public agencies are required to use the competitive bidding mode, while private organizations may choose either mode of operation. In using competitive bidding, the owner is forced to use the designer-constructor sequence since detailed plans and specifications must be ready before inviting bidders to submit their bids. If the owner chooses to use a negotiated contract, it is free to use phased construction if it so desires.

The general contractor may choose to perform all or part of the construction work, or act only as a manager by subcontracting all the construction to subcontractors. The general contractor may also select the subcontractors through competitive bidding or negotiated contracts. The general contractor may ask a number of subcontractors to quote prices for the subcontracts before submitting its bid to the owner. However, the subcontractors often cannot force the winning general contractor to use them on the project. This situation may lead to practices known as *bid shopping* and *bid peddling*. Bid shopping refers to the situation when the general contractor approaches subcontractors other than those whose quoted prices were used in the winning contract in order to seek lower priced subcontracts. Bid peddling refers to the actions of subcontractors who offer lower priced subcontracts to the winning general subcontractors in order to dislodge the subcontractors who originally quoted prices to the general contractor prior to its bid submittal. In both cases, the quality of construction may be sacrificed, and some state statutes forbid these practices for public projects.

Although the designer-constructor sequence is still widely used because of the public perception of fairness in competitive bidding, many private owners recognize the disadvantages of using this approach when the project is large and complex and when market pressures require a shorter project duration than that which can be accomplished by using this traditional method.

[Back to top](#)

## 2.7 Professional Construction Management

Professional construction management refers to a project management team consisting of a professional construction manager and other participants who will carry out the tasks of project planning, design and construction in an integrated manner. Contractual relationships among members of the team are intended to minimize adversarial relationships and contribute to greater response within the management group. A professional construction manager is a firm specialized in the practice of professional construction management which includes:

- Work with owner and the A/E firms from the beginning and make recommendations on design improvements, construction technology, schedules and construction economy.
- Propose design and construction alternatives if appropriate, and analyze the effects of the alternatives on the project cost and schedule.
- Monitor subsequent development of the project in order that these targets are not exceeded without the knowledge of the owner.
- Coordinate procurement of material and equipment and the work of all construction contractors, and monthly payments to contractors, changes, claims and inspection for conforming design requirements.
- Perform other project related services as required by owners.

Professional construction management is usually used when a project is very large or complex. The organizational features that are characteristics of mega-projects can be summarized as follows:[\[6\]](#)

- The overall organizational approach for the project will change as the project advances. The "functional" organization may change to a "matrix" which may change to a "project" organization (not necessarily in this order).
- Within the overall organization, there will probably be functional, project, and matrix suborganizations all

at the same time. This feature greatly complicates the theory and the practice of management, yet is essential for overall cost effectiveness.

- Successful giant, complex organizations usually have a strong matrix-type suborganization at the level where basic cost and schedule control responsibility is assigned. This suborganization is referred to as a "cost center" or as a "project" and is headed by a project manager. The cost center matrix may have participants assigned from many different functional groups. In turn, these functional groups may have technical reporting responsibilities to several different and higher tiers in the organization. The key to a cost effective effort is the development of this project suborganization into a single team under the leadership of a strong project manager.
- The extent to which decision-making will be centralized or decentralized is crucial to the organization of the mega-project.

Consequently, it is important to recognize the changing nature of the organizational structure as a project is carried out in various stages.

### **Example 2-5: Managing of the Alaska Pipeline Project**

The Alaska Pipeline Project was the largest, most expensive private construction project in the 1970's, which encompassed 800 miles, thousands of employees, and 10 billion dollars.

At the planning stage, the owner (a consortium) employed a Construction Management Contractor (CMC) to direct the pipeline portion, but retained centralized decision making to assure single direction and to integrate the effort of the CMC with the pump stations and the terminals performed by another contractor. The CMC also centralized its decision making in directing over 400 subcontractors and thousands of vendors. Because there were 19 different construction camps and hundreds of different construction sites, this centralization caused delays in decision making.

At about the 15% point of physical completion, the owner decided to reorganize the decision making process and change the role of the CMC. The new organization was a combination of owner and CMC personnel assigned within an integrated organization. The objective was to develop a single project team responsible for controlling all subcontractors. Instead of having nine tiers of organization from the General Manager of the CMC to the subcontractors, the new organization had only four tiers from the Senior Project Manager of the owner to subcontractors. Besides unified direction and coordination, this reduction in tiers of organization greatly improved communications and the ability to make and implement decisions. The new organization also allowed decentralization of decision making by treating five sections of the pipeline at different geographic locations as separate projects, with a section manager responsible for all functions of the section as a profit center.

At about 98% point of physical completion, all remaining activities were to be consolidated to identify single bottom-line responsibility, to reduce duplication in management staff, and to unify coordination of remaining work. Thus, the project was first handled by separate organizations but later was run by an integrated organization with decentralized profit centers. Finally, the organization in effect became small and was ready to be phased out of operation.

### **Example 2-6: Managing the Channel Tunnel Construction from Britain to France**

The underground railroad tunnel from Britain to France is commonly called the Channel Tunnel or Chunnel. It was built by tunneling from each side. Starting in 1987, the tunnels had a breakthrough in 1990.

Management turmoil dogged the project from the start. In 1989, seven of the eight top people in the construction organization left. There was a built in conflict between the contractors and government overseers: "The fundamental thing wrong is that the constructors own less than 6% of Eurotunnel.

Their interest is to build and sell the project at a profit. (Eurotunnel's) interest is for it to operate economically, safely and reliably for the next 50 years." (Alastair Morton, Eurotunnel CEO, quoted in ENR, 12/10/90, p. 56).

[Back to top](#)

## 2.8 Owner-Builder Operation

In this approach an owner must have a steady flow of on-going projects in order to maintain a large work force for in-house operation. However, the owner may choose to subcontract a substantial portion of the project to outside consultants and contractors for both design and construction, even though it retains centralized decision making to integrate all efforts in project implementation.

### Example 2-7: U.S. Army Corps of Engineers Organization

The District Engineer's Office of the U.S. Army Corps of Engineers may be viewed as a typical example of an owner-builder approach as shown in Figure 2-8.

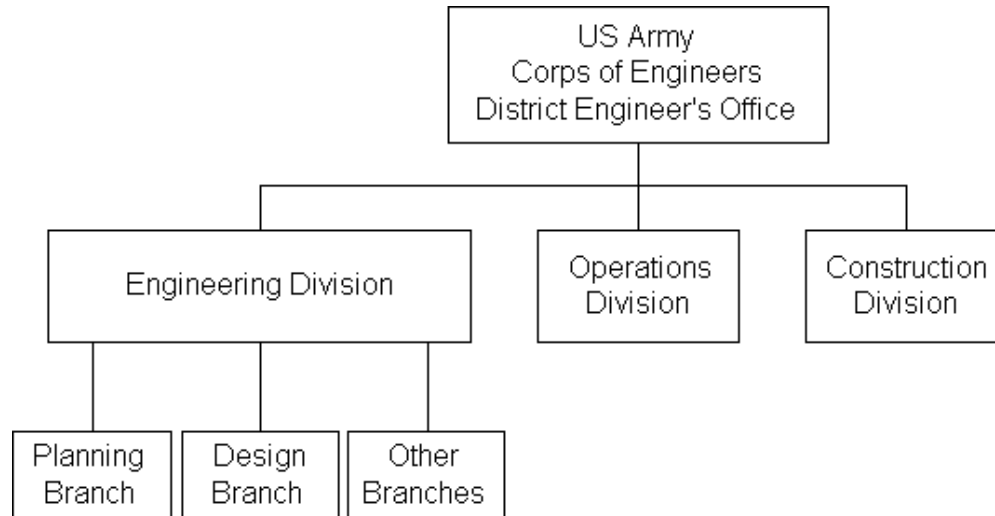

**Figure 2-8:** Organization of a District of Corps of Engineers

In the District Engineer's Office of the U.S. Corps of Engineers, there usually exist an Engineering Division and an Operations Division, and, in a large district, a Construction Division. Under each division, there are several branches. Since the authorization of a project is usually initiated by the U.S. Congress, the planning and design functions are separated in order to facilitate operations. Since the authorization of the feasibility study of a project may precede the authorization of the design by many years, each stage can best be handled by a different branch in the Engineering Division. If construction is ultimately authorized, the work may be handled by the Construction Division or by outside contractors. The Operations Division handles the operation of locks and other facilities which require routine attention and maintenance.

When a project is authorized, a project manager is selected from the most appropriate branch to head the project, together with a group of staff drawn from various branches to form the project team. When the project is completed, all members of the team including the project manager will return to their regular posts in various branches and divisions until the next project assignment. Thus, a matrix organization is used in managing each project.



[Back to top](#)

## 2.9 Turnkey Operation

Some owners wish to delegate all responsibilities of design and construction to outside consultants in a *turnkey* project arrangement. A contractor agrees to provide the completed facility on the basis of performance specifications set forth by the owner. The contractor may even assume the responsibility of operating the project if the owner so desires. In order for a turnkey operation to succeed, the owner must be able to provide a set of unambiguous performance specifications to the contractor and must have complete confidence in the capability of the contractor to carry out the mission.

This approach is the direct opposite of the owner-builder approach in which the owner wishes to retain the maximum amount of control for the design-construction process.

### Example 2-8: An Example of a Turnkey Organization

A 150-Mw power plant was proposed in 1985 by the Texas-New Mexico Power Company of Fort Worth, Texas, which would make use of the turnkey operation. [7] Upon approval by the Texas Utility Commission, a consortium consisting of H.B. Zachry Co., Westinghouse Electric Co., and Combustion Engineering, Inc. would design, build and finance the power plant for completion in 1990 for an estimated construction cost of \$200 million in 1990 dollars. The consortium would assume total liability during construction, including debt service costs, and thereby eliminate the risks of cost escalation to rate payers, stockholders and the utility company management.

[Back to top](#)

## 2.10 Leadership and Motivation for the Project Team

The project manager, in the broadest sense of the term, is the most important person for the success or failure of a project. The project manager is responsible for planning, organizing and controlling the project. In turn, the project manager receives authority from the management of the organization to mobilize the necessary resources to complete a project.

The project manager must be able to exert interpersonal influence in order to lead the project team. The project manager often gains the support of his/her team through a combination of the following:

- Formal authority resulting from an official capacity which is empowered to issue orders.
- Reward and/or penalty power resulting from his/her capacity to dispense directly or indirectly valued organization rewards or penalties.
- Expert power when the project manager is perceived as possessing special knowledge or expertise for the job.
- Attractive power because the project manager has a personality or other characteristics to convince others.

In a matrix organization, the members of the functional departments may be accustomed to a single reporting line in a hierarchical structure, but the project manager coordinates the activities of the team members drawn from functional departments. The functional structure within the matrix organization is responsible for priorities, coordination, administration and final decisions pertaining to project implementation. Thus, there are potential conflicts between functional divisions and project teams. The project manager must be given the responsibility and authority to resolve various conflicts such that the established project policy and quality standards will not be jeopardized. When contending issues of a more fundamental nature are developed, they must be brought to the attention of a high level in the management and be resolved expeditiously.

In general, the project manager's authority must be clearly documented as well as defined, particularly in a

matrix organization where the functional division managers often retain certain authority over the personnel temporarily assigned to a project. The following principles should be observed:

- The interface between the project manager and the functional division managers should be kept as simple as possible.
- The project manager must gain control over those elements of the project which may overlap with functional division managers.
- The project manager should encourage problem solving rather than role playing of team members drawn from various functional divisions.

[Back to otp](#)

## 2.11 Interpersonal Behavior in Project Organizations

While a successful project manager must be a good leader, other members of the project team must also learn to work together, whether they are assembled from different divisions of the same organization or even from different organizations. Some problems of interaction may arise initially when the team members are unfamiliar with their own roles in the project team, particularly for a large and complex project. These problems must be resolved quickly in order to develop an effective, functioning team.

Many of the major issues in construction projects require effective interventions by individuals, groups and organizations. The fundamental challenge is to enhance communication among individuals, groups and organizations so that obstacles in the way of improving interpersonal relations may be removed. Some behavior science concepts are helpful in overcoming communication difficulties that block cooperation and coordination. In very large projects, professional behavior scientists may be necessary in diagnosing the problems and advising the personnel working on the project. The power of the organization should be used judiciously in resolving conflicts.

The major symptoms of interpersonal behavior problems can be detected by experienced observers, and they are often the sources of serious communication difficulties among participants in a project. For example, members of a project team may avoid each other and withdraw from active interactions about differences that need to be dealt with. They may attempt to criticize and blame other individuals or groups when things go wrong. They may resent suggestions for improvement, and become defensive to minimize culpability rather than take the initiative to maximize achievements. All these actions are detrimental to the project organization.

While these symptoms can occur to individuals at any organization, they are compounded if the project team consists of individuals who are put together from different organizations. Invariably, different organizations have different cultures or modes of operation. Individuals from different groups may not have a common loyalty and may prefer to expand their energy in the directions most advantageous to themselves instead of the project team. Therefore, no one should take it for granted that a project team will work together harmoniously just because its members are placed physically together in one location. On the contrary, it must be assumed that good communication can be achieved only through the deliberate effort of the top management of each organization contributing to the joint venture.

[Back to top](#)

## 2.12 Perceptions of Owners and Contractors

Although owners and contractors may have different perceptions on project management for construction, they have a common interest in creating an environment leading to successful projects in which performance quality, completion time and final costs are within prescribed limits and tolerances. It is interesting therefore to note the opinions of some leading contractors and owners who were interviewed in 1984. [\[8\]](#)

From the responses of six contractors, the key factors cited for successful projects are:

- well defined scope
- extensive early planning
- good leadership, management and first line supervision
- positive client relationship with client involvement
- proper project team chemistry
- quick response to changes
- engineering managers concerned with the total project, not just the engineering elements.

Conversely, the key factors cited for unsuccessful projects are:

- ill-defined scope
- poor management
- poor planning
- breakdown in communication between engineering and construction
- unrealistic scope, schedules and budgets
- many changes at various stages of progress
- lack of good project control

The responses of eight owners indicated that they did not always understand the concerns of the contractors although they generally agreed with some of the key factors for successful and unsuccessful projects cited by the contractors. The significant findings of the interviews with owners are summarized as follows:

- All owners have the same perception of their own role, but they differ significantly in assuming that role in practice.
- The owners also differ dramatically in the amount of early planning and in providing information in bid packages.
- There is a trend toward breaking a project into several smaller projects as the projects become larger and more complex.
- Most owners recognize the importance of schedule, but they adopt different requirements in controlling the schedule.
- All agree that people are the key to project success.

From the results of these interviews, it is obvious that owners must be more aware and involved in the process in order to generate favorable conditions for successful projects. Design professionals and construction contractors must provide better communication with each other and with the owner in project implementation.

[Back to top](#)

## 2.13 References

1. Barrie, Donald S. and Boyd C. Paulson, Jr., *Professional Construction Management*, McGraw-Hill Book Company, 2nd Ed., 1984.
2. Halpin, Daniel W. and Ronald W. Woodhead, *Construction Management*, John Wiley and Sons, 1980.
3. Hodgetts, R.M., *Management: Theory, Process and Practice*, W.B. Saunders Co., Philadelphia, PA, 1979.
4. Kerzner, H. *Project Management: A Systems Approach to Planning, Scheduling and Controlling*. 2nd. Ed., Van Nostrand Reinhold, New York, 1984.
5. Levitt, R.E., R.D. Logcher and N.H. Quaddumi, "Impact of Owner-Engineer Risk Sharing on Design Conservatism," *ASCE Journal of Professional Issues in Engineering*, Vol. 110, 1984, pp. 157-167.
6. Moolin, F.P., Jr., and F.A. McCoy: "Managing the Alaska Pipeline Project," *Civil Engineering*, November 1981, pp. 51-54.
7. Murray, L., E. Gallardo, S. Aggarwal and R. Waywitka, "Marketing Construction Management Services," *ASCE Journal of Construction Division*, Vol. 107, 1981, pp. 665-677.

8. Project Management Institute, *A Guide to the Project Management Body of Knowledge*, Newtown Square, Pennsylvania, 2000.

[Back to top](#)

## 2.14 Footnotes

1. See R. M. Wideman, "The PMBOK Report -- PMI Body of Knowledge Standard," *Project Management Journal*, Vol. 17, No. 3, August 1986, pp. 15-24. [Back](#)
2. See L. C. Stuckenbruck, "Project Management Framework," *Project Management Journal*, Vol. 17, No. 3, August 1986, pp. 25-30. [Back](#)
3. See, for example, O'Connor, J.T., and Vickory, C.G., *Control of Construction Project Scope*, A Report to the Construction Industry Institute, The University of Texas at Austin, December 1985. [Back](#)
4. See, for example, Federal Form 23-A and EPA's Appendix C-2 clauses. [Back](#)
5. See E. D'Appolonia, "Coping with Uncertainty in Geotechnical Engineering and Construction," *Special Proceedings of the 9th International Conference on Soil Mechanics and Foundation Engineering*, Tokyo, Japan, Vol. 4, 1979, pp. 1-18. [Back](#)
6. These features and the following example are described in F.P. Moolin, Jr. and F.A. McCoy, "Managing the Alaska Pipeline Project," *Civil Engineering*, November 1981, pp. 51-54. [Back](#)
7. "Private Money Finances Texas Utility's Power Plant" *Engineering News Record*: July 25, 1985, p. 13. [Back](#)
8. See J.E. Diekmann and K.B. Thrush, *Project Control in Design Engineering*, A Report to the Construction Industry Institute, The University of Texas at Austin, Texas, May 1986. [Back](#)

[Previous Chapter](#) | [Table of Contents](#) | [Next Chapter](#)

<a href="#">Go Up to Table of Contents</a>	
<a href="#">Go To Chapter 2 (Organizing For Project Management)</a>	<a href="#">Go To Chapter 4 (Labor, Material, And Equipment Utilization.)</a>
<i>The Design and Construction Process</i>	
<a href="#">Design and Construction as an Integrated System</a>	
<a href="#">Innovation and Technological Feasibility</a>	
<a href="#">Innovation and Economic Feasibility</a>	
<a href="#">Design Methodology</a>	
<a href="#">Functional Design</a>	
<a href="#">Physical Structures</a>	
<a href="#">Geotechnical Engineering</a>	
<a href="#">Investigation</a>	
<a href="#">Construction Site Environment</a>	
<a href="#">Value Engineering</a>	
<a href="#">Construction Planning</a>	
<a href="#">Industrialized Construction and Pre-fabrication</a>	
<a href="#">Computer-Aided Engineering</a>	
<a href="#">Pre-Project Planning</a>	
<a href="#">References</a>	
<a href="#">Footnotes</a>	



[http://pmbook.ce.cmu.edu/03\\_The\\_Design\\_And\\_Construction\\_Process.html](http://pmbook.ce.cmu.edu/03_The_Design_And_Construction_Process.html)

## 3. The Design and Construction Process

### 3.1 Design and Construction as an Integrated System

In the planning of facilities, it is important to recognize the close relationship between design and construction. These processes can best be viewed as an integrated system. Broadly speaking, design is a process of creating the description of a new facility, usually represented by detailed plans and specifications; construction planning is a process of identifying activities and resources required to make the design a physical reality. Hence, construction is the implementation of a design envisioned by architects and engineers. In both design and construction, numerous operational tasks must be performed with a variety of precedence and other relationships among the different tasks.

Several characteristics are unique to the planning of constructed facilities and should be kept in mind even at the very early stage of the project life cycle. These include the following:

- Nearly every facility is custom designed and constructed, and often requires a long time to complete.
- Both the design and construction of a facility must satisfy the conditions peculiar to a specific site.
- Because each project is site specific, its execution is influenced by natural, social and other locational conditions such as weather, labor supply, local building codes, etc.
- Since the service life of a facility is long, the anticipation of future requirements is inherently difficult.
- Because of technological complexity and market demands, changes of design plans during construction are not uncommon.

In an integrated system, the planning for both design and construction can proceed almost simultaneously, examining various alternatives which are desirable from both viewpoints and thus eliminating the necessity of extensive revisions under the guise of value engineering. Furthermore, the review of designs with regard to their constructibility can be carried out as the project progresses from planning to design. For example, if the sequence of assembly of a structure and the critical loadings on the partially assembled structure during construction are carefully considered as a part of the overall structural design, the impacts of the design on construction falsework and on assembly details can be anticipated. However, if the design professionals are expected to assume such responsibilities, they must be rewarded for sharing the risks as well as for undertaking these additional tasks. Similarly, when construction contractors are expected to take over the responsibilities of engineers, such as devising a very elaborate scheme to erect an unconventional structure, they too must be rewarded accordingly. As long as the owner does not assume the responsibility for resolving this risk-reward dilemma, the concept of a truly integrated system for design and construction cannot be realized.

It is interesting to note that European owners are generally more open to new technologies and to share risks with designers and contractors. In particular, they are more willing to accept responsibilities for the unforeseen subsurface conditions in geotechnical engineering. Consequently, the designers and contractors are also more willing to introduce new techniques in order to reduce the time and cost of construction. In European practice, owners typically present contractors with a conceptual design, and contractors prepare detailed designs, which are checked by the owner's engineers. Those detailed designs may be alternate designs, and specialty contractors may also prepare detailed alternate designs.

### Example 3-1: Responsibility for Shop Drawings

The willingness to assume responsibilities does not come easily from any party in the current litigious climate of the construction industry in the United States. On the other hand, if owner, architect, engineer, contractor and other groups that represent parts of the industry do not jointly fix the responsibilities of various tasks to appropriate parties, the standards of practice will eventually be set by court decisions. In an attempt to provide a guide to the entire spectrum of participants in a construction project, the American Society of Civil Engineers issued a Manual of Professional Practice entitled *Quality in the Constructed Project* in 1990. This manual is intended to help bring a turn around of the fragmentation of activities in the design and construction process.

Shop drawings represent the assembly details for erecting a structure which should reflect the intent and rationale of the original structural design. They are prepared by the construction contractor and reviewed by the design professional. However, since the responsibility for preparing shop drawings was traditionally assigned to construction contractors, design professionals took the view that the review process was advisory and assumed no responsibility for their accuracy. This justification was ruled unacceptable by a court in connection with the walkway failure at the Hyatt Hotel in Kansas City in 1985. In preparing the ASCE Manual of Professional Practice for Quality in the Constructed Project, the responsibilities for preparation of shop drawings proved to be the most difficult to develop. [1] The reason for this situation is not difficult to fathom since the responsibilities for the task are diffused, and all parties must agree to the new responsibilities assigned to each in the recommended risk-reward relations shown in Table 3-1.

Traditionally, the owner is not involved in the preparation and review of shop drawings, and perhaps is even unaware of any potential problems. In the recommended practice, the owner is required to take responsibility for providing adequate time and funding, including approval of scheduling, in order to allow the design professionals and construction contractors to perform satisfactorily.

**Table 3-1** Recommended Responsibility for Shop Drawings

Task	Responsible Party		
	Owner	Design Professional	Construction Contractor
Provide adequate time and funding for shop drawing preparation and review	Prime		

Arrange for structural design	Prime		
Provide structural design		Prime	
Establish overall responsibility for connection design		Prime	
Accomplish connection design (by design professional)		Prime	
Alternatively, provide loading requirement and other information necessary for shop drawing preparation		Prime	
Alternatively, accomplish some or all of connection design (by constructor with a licensed P.E.)			Prime
Specify shop drawing requirements and procedures	Review	Prime	
Approve proper scheduling	Prime	Assisting	Assisting
Provide shop drawing and submit the drawing on schedule			Prime
Make timely reviews and approvals		Prime	
Provide erection procedures, construction bracing, shoring, means, methods and techniques of construction, and construction safety			Prime

### Example 3-2: Model Metro Project in Milan, Italy [2]

Under Italian law, unforeseen subsurface conditions are the owner's responsibility, not the contractor's. This is a striking difference from U.S. construction practice where changed conditions clauses and claims and the adequacy of prebid site investigations are points of contention. In effect, the Italian law means that the owner assumes those risks. But under the same law, a contractor may elect to assume the risks in order to lower the bid price and thereby beat the competition.

According to the Technical Director of Rodio, the Milan-based contractor which is heavily involved in the grouting job for tunneling in the Model Metro project in Milan, Italy, there are two typical contractual arrangements for specialized subcontractor firms such as theirs. One is to work on a unit price basis with no responsibility for the design. The other is what he calls the "nominated subcontractor" or turnkey method: prequalified subcontractors offer their own designs and guarantee the price, quality, quantities, and, if they wish, the risks of unforeseen conditions.

At the beginning of the Milan metro project, the Rodio contract ratio was 50/50 unit price and turnkey. The firm convinced the metro owners that they would save money with the turnkey approach, and the ratio became 80% turnkey. What's more, in the work packages where Rodio worked with other grouting specialists, those subcontractors paid Rodio a fee to assume all risks for unforeseen conditions.

Under these circumstances, it was critical that the firm should know the subsurface conditions as precisely as possible, which was a major reason why the firm developed a computerized electronic sensing program to predict stratigraphy and thus control grout mixes, pressures and, most important, quantities.

## 3.2 Innovation and Technological Feasibility

The planning for a construction project begins with the generation of concepts for a facility which will meet market demands and owner needs. Innovative concepts in design are highly valued not for their own sake but for their contributions to reducing costs and to the improvement of aesthetics, comfort or convenience as embodied in a well-designed facility. However, the constructor as well as the design professionals must have an appreciation and full understanding of the technological complexities often associated with innovative designs in order to provide a safe and sound facility. Since these concepts are often preliminary or tentative, screening studies are carried out to determine the overall technological viability and economic attractiveness without pursuing these concepts in great detail. Because of the ambiguity of the objectives and the uncertainty of external events, screening studies call for uninhibited innovation in creating new concepts and judicious judgment in selecting the appropriate ones for further consideration.

One of the most important aspects of design innovation is the necessity of communication in the design/construction

partnership. In the case of bridge design, it can be illustrated by the following quotation from Lin and Gerwick concerning bridge construction: [3]

The great pioneering steel bridges of the United States were built by an open or covert alliance between designers and constructors. The turnkey approach of designer-constructor has developed and built our chemical plants, refineries, steel plants, and nuclear power plants. It is time to ask, seriously, whether we may not have adopted a restrictive approach by divorcing engineering and construction in the field of bridge construction.

If a contractor-engineer, by some stroke of genius, were to present to design engineers today a wonderful new scheme for long span prestressed concrete bridges that made them far cheaper, he would have to make these ideas available to all other constructors, even limiting or watering them down so as to "get a group of truly competitive bidders." The engineer would have to make sure that he found other contractors to bid against the ingenious innovator.

If an engineer should, by a similar stroke of genius, hit on such a unique and brilliant scheme, he would have to worry, wondering if the low bidder would be one who had any concept of what he was trying to accomplish or was in any way qualified for high class technical work.

Innovative design concepts must be tested for technological feasibility. Three levels of technology are of special concern: technological requirements for operation or production, design resources and construction technology. The first refers to the new technologies that may be introduced in a facility which is used for a certain type of production such as chemical processing or nuclear power generation. The second refers to the design capabilities that are available to the designers, such as new computational methods or new materials. The third refers to new technologies which can be adopted to construct the facility, such as new equipment or new construction methods.

A new facility may involve complex new technology for operation in hostile environments such as severe climate or restricted accessibility. Large projects with unprecedented demands for resources such as labor supply, material and infrastructure may also call for careful technological feasibility studies. Major elements in a feasibility study on production technology should include, but are not limited to, the following:

- Project type as characterized by the technology required, such as synthetic fuels, petrochemicals, nuclear power plants, etc.
- Project size in dollars, design engineer's hours, construction labor hours, etc.
- Design, including sources of any special technology which require licensing agreements.
- Project location which may pose problems in environmental protection, labor productivity and special risks.

An example of innovative design for operation and production is the use of entropy concepts for the design of integrated chemical processes. Simple calculations can be used to indicate the minimum energy requirements and the least number of heat exchange units to achieve desired objectives. The result is a new incentive and criterion for designers to achieve more effective designs. Numerous applications of the new methodology has shown its efficacy in reducing both energy costs and construction expenditures. [4] This is a case in which innovative design is not a matter of trading-off operating and capital costs, but better designs can simultaneously achieve improvements in both objectives.

The choice of construction technology and method involves both *strategic* and *tactical* decisions about appropriate technologies and the best sequencing of operations. For example, the extent to which prefabricated facility components will be used represents a *strategic* construction decision. In turn, prefabrication of components might be accomplished off-site in existing manufacturing facilities or a temporary, on-site fabrication plant might be used. Another example of a strategic decision is whether to install mechanical equipment in place early in the construction process or at an intermediate stage. Strategic decisions of this sort should be integrated with the process of facility design in many cases. At the tactical level, detailed decisions about how to accomplish particular tasks are required, and such decisions can often be made in the field.

Construction planning should be a major concern in the development of facility designs, in the preparation of cost estimates, and in forming bids by contractors. Unfortunately, planning for the construction of a facility is often



treated as an after thought by design professionals. This contrasts with manufacturing practices in which the *assembly* of devices is a major concern in design. Design to insure ease of assembly or construction should be a major concern of engineers and architects. As the Business Roundtable noted, "All too often chances to cut schedule time and costs are lost because construction operates as a production process separated by a chasm from financial planning, scheduling, and engineering or architectural design. Too many engineers, separated from field experience, are not up to date about how to build what they design, or how to design so structures and equipment can be erected most efficiently." [5]

### Example 3-3: Innovative use of structural frames for buildings [6]

The structural design of skyscrapers offers an example of innovation in overcoming the barrier of high costs for tall buildings by making use of new design capabilities. A revolutionary concept in skyscraper design was introduced in the 1960's by Fazlur Khan who argued that, for a building of a given height, there is an appropriate structural system which would produce the most efficient use of the material.

Before 1965, most skyscrapers were steel rigid frames. However, Fazlur Khan believed that it was uneconomical to construct all office buildings of rigid frames, and proposed an array of appropriate structural systems for steel buildings of specified heights as shown in Figure 3-1. By choosing an appropriate structural system, an engineer can use structural materials more efficiently. For example, the 60-story Chase Manhattan Building in New York used about 60 pounds per square foot of steel in its rigid frame structure, while the 100-story John Hancock Center in Chicago used only 30 pounds per square foot for a trussed tube system. At the time the Chase Manhattan Building was constructed, no bracing was used to stiffen the core of a rigid frame building because design engineers did not have the computing tools to do the complex mathematical analysis associated with core bracing.

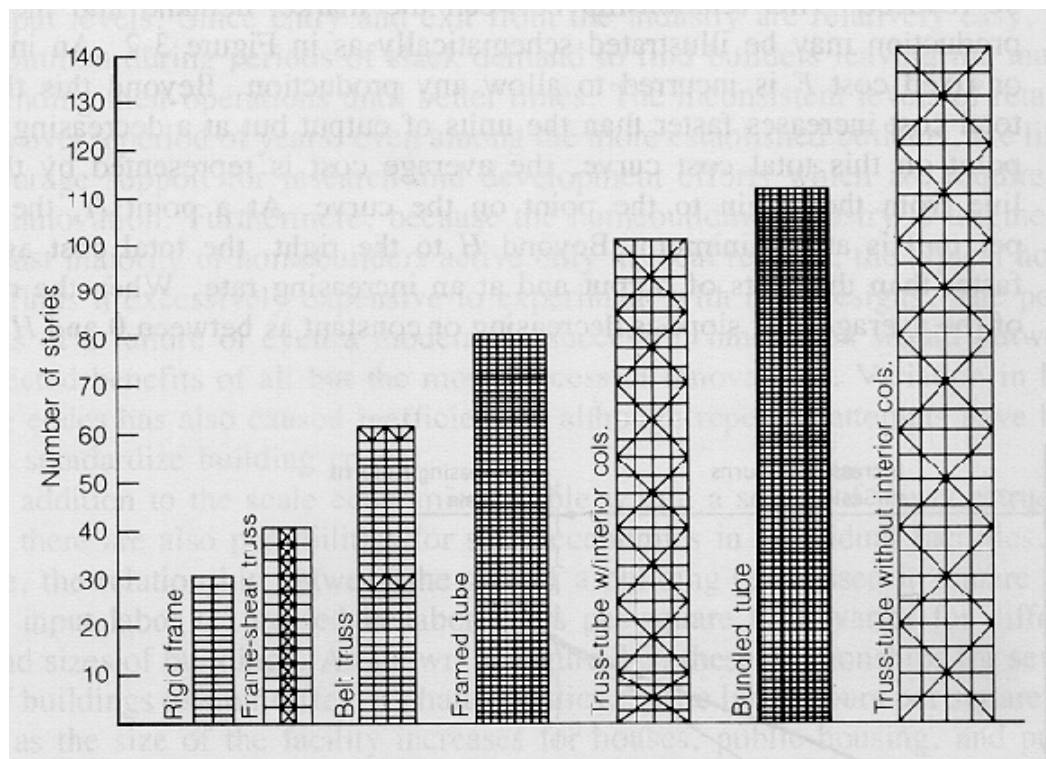

**Figure 3-1:** Proposed Structural System for Steel Buildings  
(Reprinted with permission from *Civil Engineering*, May 1983)

## 3.3 Innovation and Economic Feasibility

Innovation is often regarded as the engine which can introduce construction economies and advance labor

productivity. This is obviously true for certain types of innovations in industrial production technologies, design capabilities, and construction equipment and methods. However, there are also limitations due to the economic infeasibility of such innovations, particularly in the segments of construction industry which are more fragmented and permit ease of entry, as in the construction of residential housing.

Market demand and firm size play an important role in this regard. If a builder is to construct a larger number of similar units of buildings, the cost per unit may be reduced. This relationship between the market demand and the total cost of production may be illustrated schematically as in Figure 3-2. An initial threshold or fixed cost  $F$  is incurred to allow any production. Beyond this threshold cost, total cost increases faster than the units of output but at a decreasing rate. At each point on this total cost curve, the average cost is represented by the slope of a line from the origin to the point on the curve. At a point  $H$ , the average cost per unit is at a minimum. Beyond  $H$  to the right, the total cost again increases faster than the units of output and at an increasing rate. When the rate of change of the average cost slope is decreasing or constant as between  $0$  and  $H$  on the curve, the range between  $0$  and  $H$  is said to be *increasing return to scale*; when the rate of change of the average cost slope is increasing as beyond  $H$  to the right, the region is said to be *decreasing return to scale*. Thus, if fewer than  $h$  units are constructed, the unit price will be higher than that of exactly  $h$  units. On the other hand, the unit price will increase again if more than  $h$  units are constructed.

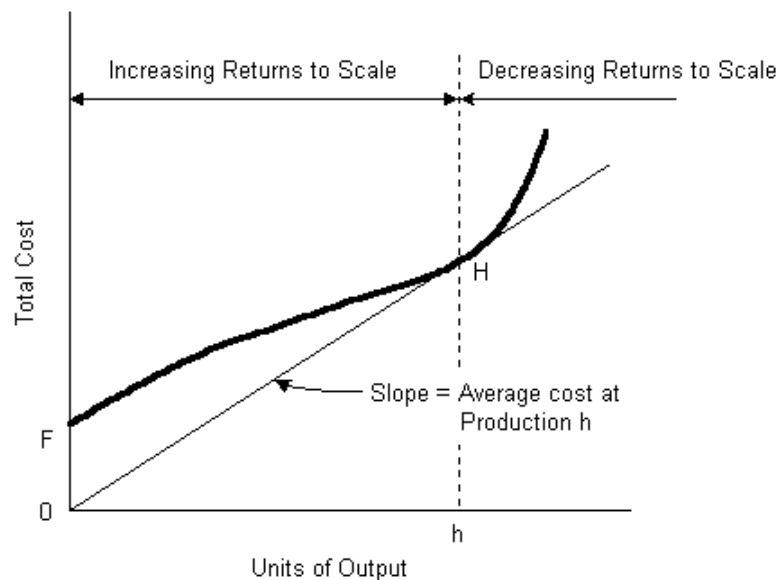

**Figure 3-2:** Market Demand and Total Cost Relationship

Nowhere is the effect of market demand and total cost more evident than in residential housing. [7] The housing segment in the last few decades accepted many innovative technical improvements in building materials which were promoted by material suppliers. Since material suppliers provide products to a large number of homebuilders and others, they are in a better position to exploit production economies of scale and to support new product development. However, homebuilders themselves have not been as successful in making the most fundamental form of innovation which encompasses changes in the technological process of homebuilding by shifting the mixture of labor and material inputs, such as substituting large scale off-site prefabrication for on-site assembly.

There are several major barriers to innovation in the technological process of homebuilding, including demand instability, industrial fragmentation, and building codes. Since market demand for new homes follows demographic trends and other socio-economic conditions, the variation in home building has been anything but regular. The profitability of the homebuilding industry has closely matched aggregate output levels. Since entry and exist from the industry are relatively easy, it is not uncommon during periods of slack demand to find builders leaving the market or suspending their operations until better times. The inconsistent levels of retained earnings over a period of years, even among the more established builders, are likely to discourage support for research and development efforts which are required to nurture innovation. Furthermore, because the homebuilding industry is fragmented with a vast majority of homebuilders active only in local regions, the typical homebuilder finds it excessively

expensive to experiment with new designs. The potential costs of a failure or even a moderately successful innovation would outweigh the expected benefits of all but the most successful innovations. Variation in local building codes has also caused inefficiencies although repeated attempts have been made to standardize building codes.

In addition to the scale economies visible within a sector of the construction market, there are also possibilities for scale economies in individual facility. For example, the relationship between the size of a building (expressed in square feet) and the input labor (expressed in laborhours per square foot) varies for different types and sizes of buildings. As shown in Figure 3-3, these relationships for several types of buildings exhibit different characteristics. [8] The labor hours per square foot decline as the size of facility increases for houses, public housing and public buildings. However, the labor hours per square foot almost remains constant for all sizes of school buildings and increases as the size of a hospital facility increases.

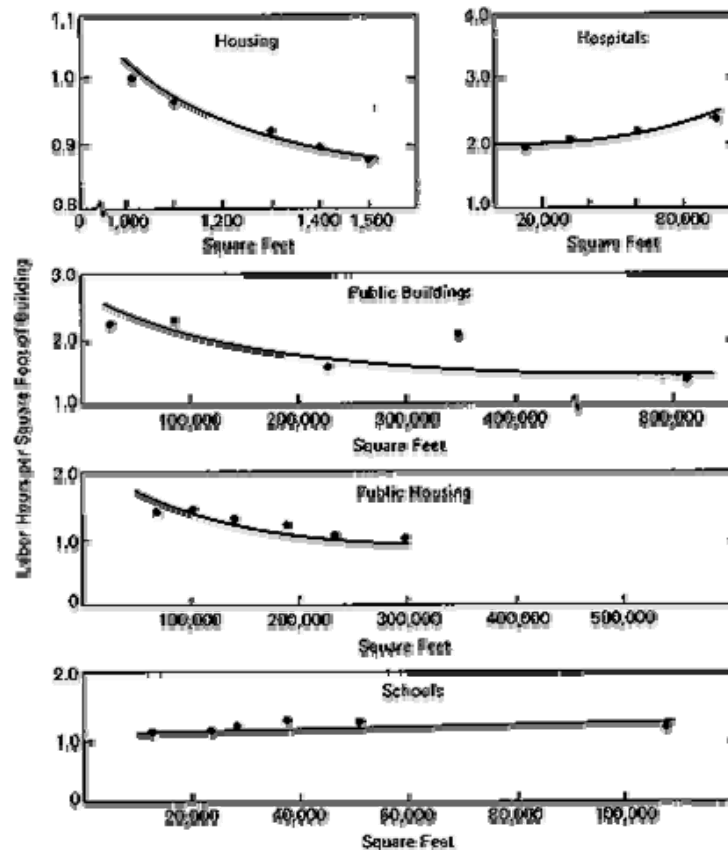

**Figure 3-3:** Illustrative Relationships between Building Size and Input Labor by Types of Building  
(Reprinted with permission from P.J. Cassimatis, *Economics of the Construction Industry*,  
The National Industry Conference Board, SEB, No. 111, 1969, p.53)

#### Example 3-4: Use of new materials [9]

In recent years, an almost entirely new set of materials is emerging for construction, largely from the aerospace and electronics industries. These materials were developed from new knowledge about the structure and properties of materials as well as new techniques for altering existing materials. Additives to traditional materials such as concrete and steel are particularly prominent. For example, it has been known for some time that polymers would increase concrete strength, water resistance and ability to insulate when they are added to the cement. However, their use has been limited by their costs since they have had to replace as much as 10 percent of the cement to be effective. However, Swedish researchers have helped reduce costs by using polymer microspheres 8 millionths of an inch across, which occupy less than 1 percent of the cement. Concretes made with these microspheres meet even the

strict standards for offshore structures in the North Sea. Research on micro-additives will probably produce useful concretes for repairing road and bridges as well.

### Example 3-5: Green Buildings [10]

The Leadership in Energy and Environmental Design (LEED) Green Building Rating System is intended to promote voluntary improvements in design and construction practices. In the rating system, buildings receive points for a variety of aspects, including reduced energy use, greater use of daylight rather than artificial lights, recycling construction waste, rainfall runoff reduction, availability of public transit access, etc. If a building accumulates a sufficient number of points, it may be certified by the Green Building Alliance as a "green building." While some of these aspects may increase construction costs, many reduce operating costs or make buildings more attractive. Green building approaches are spreading to industrial plants and other types of construction.

## 3.4 Design Methodology

While the conceptual design process may be formal or informal, it can be characterized by a series of actions: formulation, analysis, search, decision, specification, and modification. However, at the early stage in the development of a new project, these actions are highly interactive as illustrated in Figure 3-4. [11] Many iterations of redesign are expected to refine the functional requirements, design concepts and financial constraints, even though the analytic tools applied to the solution of the problem at this stage may be very crude.

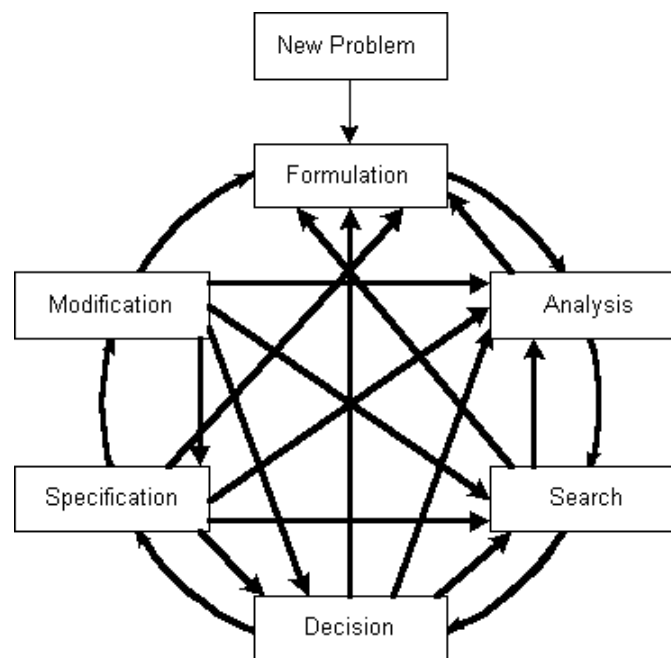

**Figure 3-4:** Conceptual Design Process

(Adapted with permission from R.W. Jensen and C.C. Tonies, *Software Engineering*, Prentice Hall, Englewood Cliffs, NJ, 1979, p.22)

The series of actions taken in the conceptual design process may be described as follows:

- Formulation refers to the definition or description of a design problem in broad terms through the synthesis of ideas describing alternative facilities.
- Analysis refines the problem definition or description by separating important from peripheral information and by pulling together the essential detail. Interpretation and prediction are usually required as part of the analysis.
- Search involves gathering a set of potential solutions for performing the specified functions and satisfying the

user requirements.

- Decision means that each of the potential solutions is evaluated and compared to the alternatives until the best solution is obtained.
- Specification is to describe the chosen solution in a form which contains enough detail for implementation.
- Modification refers to the change in the solution or re-design if the solution is found to be wanting or if new information is discovered in the process of design.

As the project moves from conceptual planning to detailed design, the design process becomes more formal. In general, the actions of formulation, analysis, search, decision, specification and modification still hold, but they represent specific steps with less random interactions in detailed design. The design methodology thus formalized can be applied to a variety of design problems. For example, the analogy of the schematic diagrams of the structural design process and of the computer program development process is shown in Figure 3-5 [\[12\]](#).

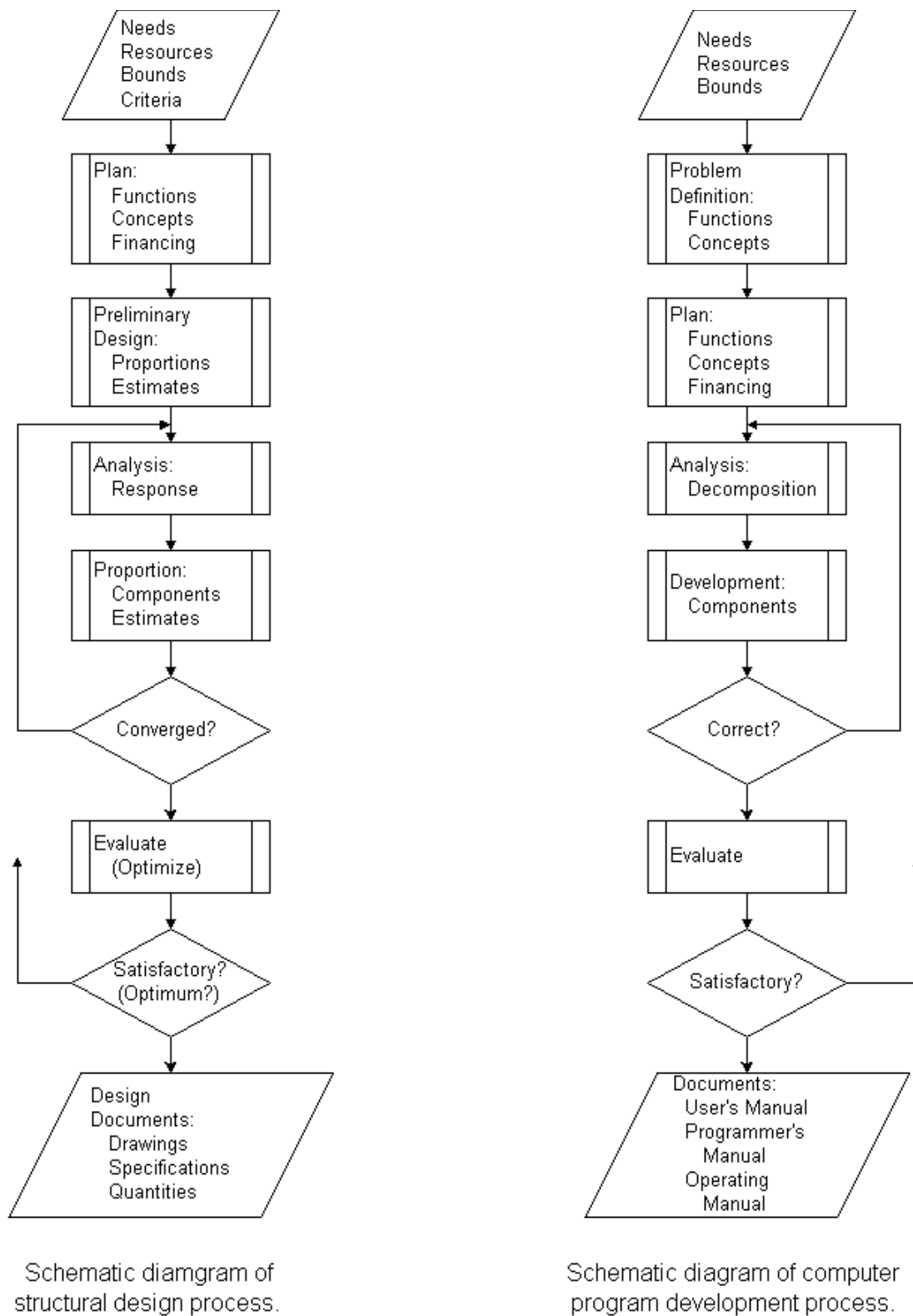

**Figure 3-5:** An Analogy Between Structural Design and Computer Program Development Process  
(Reprinted with permission from E.H. Gaylord and C. N. Gaylord, eds., *Structural Engineering Handbook*, 2nd Ed., McGraw-Hill Book Company, New York, 1979.)

The basic approach to design relies on decomposition and integration. Since design problems are large and complex, they have to be decomposed to yield subproblems that are small enough to solve. There are numerous alternative

ways to decompose design problems, such as decomposition by functions of the facility, by spatial locations of its parts, or by links of various functions or parts. Solutions to subproblems must be integrated into an overall solution. The integration often creates conceptual conflicts which must be identified and corrected. A hierarchical structure with an appropriate number of levels may be used for the decomposition of a design problem to subproblems. For example, in the structural design of a multistory building, the building may be decomposed into floors, and each floor may in turn be decomposed into separate areas. Thus, a hierarchy representing the levels of building, floor and area is formed.

Different design styles may be used. The adoption of a particular style often depends on factors such as time pressure or available design tools, as well as the nature of the design problem. Examples of different styles are:

- **Top-down design.** Begin with a behavior description of the facility and work towards descriptions of its components and their interconnections.
- **Bottom-up design.** Begin with a set of components, and see if they can be arranged to meet the behavior description of the facility.

The design of a new facility often begins with the search of the files for a design that comes as close as possible to the one needed. The design process is guided by accumulated experience and intuition in the form of heuristic rules to find acceptable solutions. As more experience is gained for this particular type of facility, it often becomes evident that parts of the design problem are amenable to rigorous definition and algorithmic solution. Even formal optimization methods may be applied to some parts of the problem.

### 3.5 Functional Design

The objective of functional design for a proposed facility is to treat the facility as a complex system of interrelated spaces which are organized systematically according to the functions to be performed in these spaces in order to serve a collection of needs. The arrangement of physical spaces can be viewed as an iterative design process to find a suitable floor plan to facilitate the movement of people and goods associated with the operations intended.

A designer often relies on a heuristic approach, i.e., applying selected rules or strategies serving to stimulate the investigation in search for a solution. The heuristic approach used in arranging spatial layouts for facilities is based generally on the following considerations:

1. identification of the goals and constraints for specified tasks,
2. determination of the current state of each task in the iterative design process,
3. evaluation of the differences between the current state and the goals,
4. means of directing the efforts of search towards the goals on the basis of past experience.

Hence, the procedure for seeking the goals can be recycled iteratively in order to make tradeoffs and thus improve the solution of spatial layouts.

Consider, for example, an integrated functional design for a proposed hospital. [13] Since the responsibilities for satisfying various needs in a hospital are divided among different groups of personnel within the hospital administrative structure, a hierarchy of functions corresponding to different levels of responsibilities is proposed in the systematic organization of hospital functions. In this model, the functions of a hospital system are decomposed into a hierarchy of several levels:

1. **Hospital**--conglomerate of all hospital services resulting from top policy decisions,
2. **Division**--broadly related activities assigned to the same general area by administrative decisions,
3. **Department**--combination of services delivered by a service or treatment group,
4. **Suite**--specific style of common services or treatments performed in the same suite of rooms,
5. **Room**--all activities that can be carried out in the same internal environment surrounded by physical barriers,
6. **Zone**--several closely related activities that are undertaken by individuals,
7. **Object**--a single activity associated with an individual.

In the integrated functional design of hospitals, the connection between physical spaces and functions is most easily

made at the lowest level of the hierarchy, and then extended upward to the next higher level. For example, a bed is a physical object immediately related to the activity of a patient. A set of furniture consisting of a bed, a night table and an armchair arranged comfortably in a zone indicates the sphere of private activities for a patient in a room with multiple occupancy. Thus, the spatial representation of a hospital can be organized in stages starting from the lowest level and moving to the top. In each step of the organization process, an element (space or function) under consideration can be related directly to the elements at the levels above it, to those at the levels below it, and to those within the same level.

Since the primary factor relating spaces is the movement of people and supplies, the objective of arranging spaces is the minimization of movement within the hospital. On the other hand, the internal environmental factors such as atmospheric conditions (pressure, temperature, relative humidity, odor and particle pollution), sound, light and fire protection produce constraining effects on the arrangement of spaces since certain spaces cannot be placed adjacent to other spaces because of different requirements in environmental conditions. The consideration of logistics is important at all levels of the hospital system. For example, the travel patterns between objects in a zone or those between zones in a room are frequently equally important for devising an effective design. On the other hand, the adjacency desirability matrix based upon environmental conditions will not be important for organization of functional elements below the room level since a room is the lowest level that can provide a physical barrier to contain desirable environmental conditions. Hence, the organization of functions for a new hospital can be carried out through an interactive process, starting from the functional elements at the lowest level that is regarded as stable by the designer, and moving step by step up to the top level of the hierarchy. Due to the strong correlation between functions and the physical spaces in which they are performed, the arrangement of physical spaces for accommodating the functions will also follow the same iterative process. Once a satisfactory spatial arrangement is achieved, the hospital design is completed by the selection of suitable building components which complement the spatial arrangement.

### Example 3-6: Top-down design style

In the functional design of a hospital, the designer may begin with a "reference model", i.e. the spatial layouts of existing hospitals of similar size and service requirements. On the basis of past experience, spaces are allocated to various divisions as shown schematically in Figure 3-6. The space in each division is then divided further for various departments in the division, and all the way down the line of the hierarchy. In every step along the way, the pertinent information of the elements immediately below the level under consideration will be assessed in order to provide input for making necessary adjustments at the current level if necessary. The major drawback of the top-down design style is that the connection between physical spaces and functions at lower levels cannot be easily anticipated. Consequently, the new design is essentially based on the intuition and experience of the designer rather than an objective analysis of the functions and space needs of the facility. Its greatest attraction is its simplicity which keeps the time and cost of design relatively low.

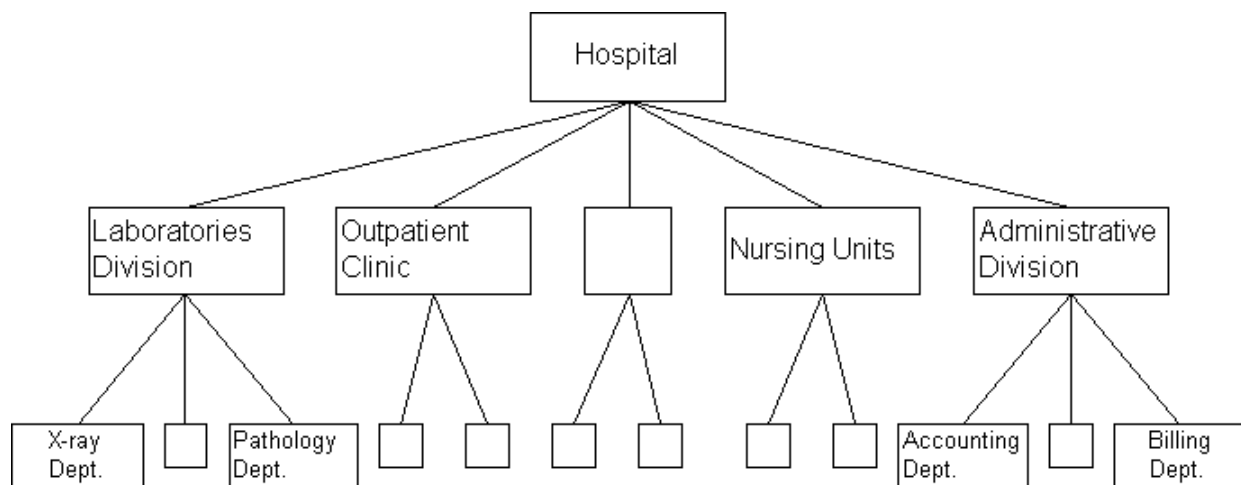
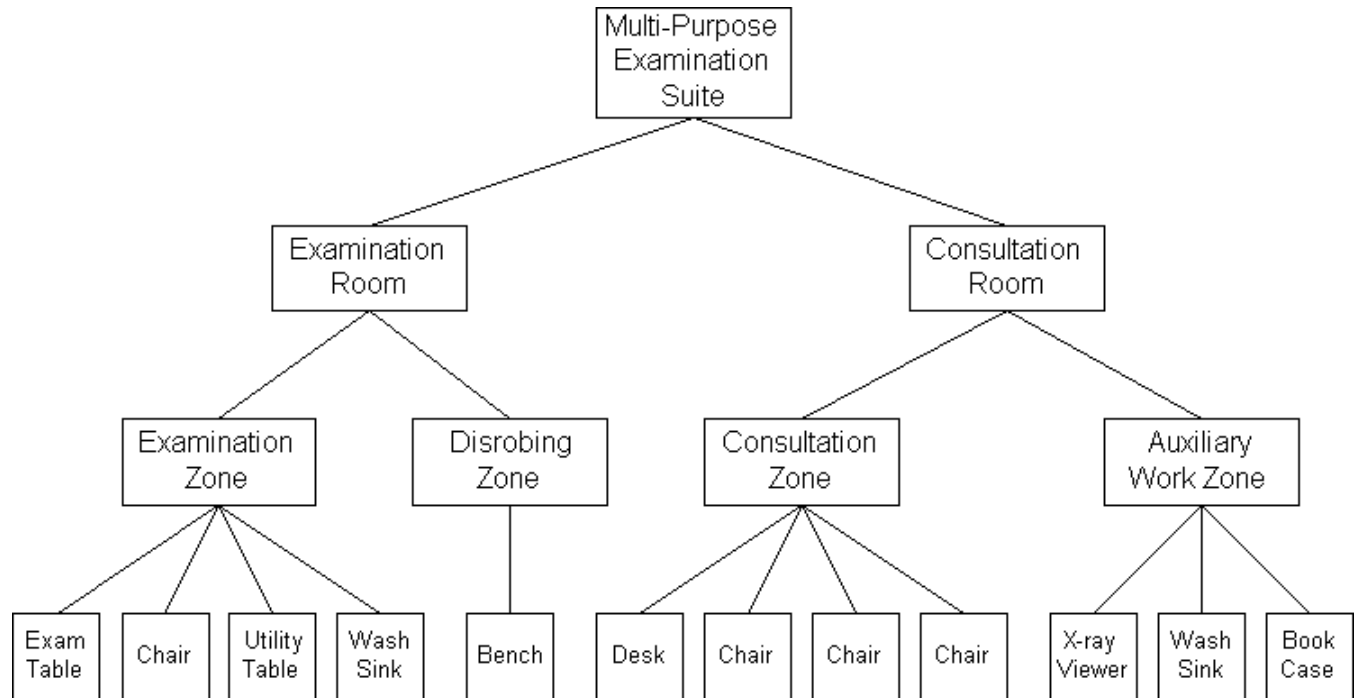

**Figure 3-6:** A Model for Top-Down Design of a Hospital



**Example 3-7: Bottom-up design style**

A multi-purpose examination suite in a hospital is used as an illustration of bottom-up design style. In Figure 3-7, the most basic elements (furniture) are first organized into zones which make up the room. Thus the size of the room is determined by spatial layout required to perform the desired services. Finally, the suite is defined by the rooms which are parts of the multi-purpose examination suite.



**Figure 3-7:** A Model for Bottom-up design of an Examination Suite

### 3.6 Physical Structures

The structural design of complex engineering systems generally involves both synthesis and analysis. Synthesis is an inductive process while analysis is a deductive process. The activities in synthesis are often described as an art rather than a science, and are regarded more akin to creativity than to knowledge. The conception of a new structural system is by and large a matter of subjective decision since there is no established procedure for generating innovative and highly successful alternatives. The initial selection of a workable system from numerous possible alternatives relies heavily on the judicious judgment of the designer. Once a structural system is selected, it must be subjected to vigorous analysis to insure that it can sustain the demands in its environment. In addition, compatibility of the structural system with mechanical equipment and piping must be assured.

For traditional types of structures such as office buildings, there are standard systems derived from the past experience of many designers. However, in many situations, special systems must be developed to meet the specified requirements. The choice of materials for a structure depends not only on the suitability of materials and their influence on the form of the structure. For example, in the design of an airplane hangar, a steel skeleton frame may be selected because a similar frame in reinforced concrete will limit the span of the structure owing to its unfavorable ratio or resistance to weight. However, if a thin-shelled roof is adopted, reinforced concrete may prove to be more suitable than steel. Thus, the interplay of the structural forms and materials affects the selection of a structural system, which in turn may influence the method of construction including the use of falsework.

**Example 3-8: Steel frame supporting a turbo-blower** [\[14\]](#)

The design of a structural frame supporting a turbo-blower supplying pressurized air to a blast furnace in a steel mill can be used to illustrate the structural design process. As shown in Figure 3-8, the turbo-

blower consists of a turbine and a blower linked to an air inlet stack. Since the vibration of the turbo-blower is a major concern to its operation, a preliminary investigation calls for a supporting frame which is separated from the structural frame of the building. An analysis of the vibration characteristics of the turbo-blower indicates that the lowest mode of vibration consists of independent vibration of the turbine shaft and the blower shaft, with higher modes for the coupled turbo-blower system when both shafts vibrate either in-phase or out-of-phase. Consequently, a steel frame with separate units for the blower side and the turbine side is selected. The columns of the steel frame are mounted on pile foundation and all joints of the steel frame are welded to reduce the vibration levels.

Since the structural steel frame also supports a condenser, an air inlet and exhaust, and a steam inlet and exhaust in addition to the turbo-blower, a static analysis is made to size its members to support all applied loads. Then, a dynamic analysis is conducted to determine the vibration characteristics of the system incorporating the structural steel frame and the turbo-blower. When the limiting conditions for static loads and natural frequencies of vibration are met, the design is accepted as satisfactory.

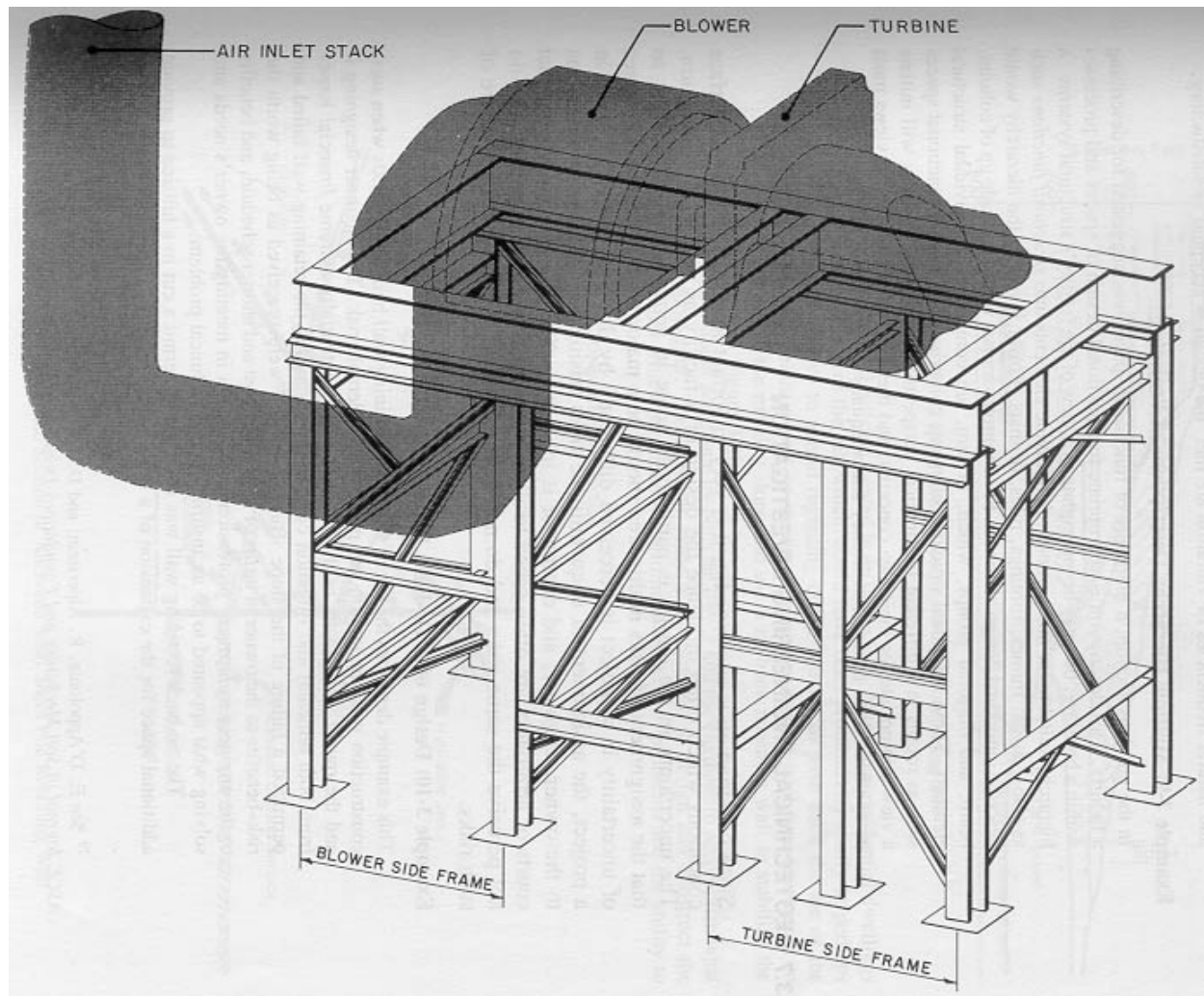

**Figure 3-8:** Steel Frame Supporting a Turbo-Blower

#### **Example 3-9:** *Multiple hierarchy descriptions of projects*

In the previous section, a hierarchy of functional spaces was suggested for describing a facility. This description is appropriate for functional design of spaces and processes within a building, but may be inadequate as a view of the facility's structural systems. A hierarchy suitable for this purpose might divide elements into *structural functions* such as slabs, walls, frames, footings, piles or mats. Lower

levels of the hierarchy would describe individual design elements. For example, frames would be made up of column, beam and diagonal groups which, in turn, are composed of individual structural elements. These individual structural elements comprise the limits on functional spaces such as rooms in a different hierarchical perspective. Designers typically will initiate a view appropriate for their own concerns, and these different hierarchical views must be synthesized to insure consistency and adequacy of the overall design.

### 3.7 Geotechnical Engineering Investigation

Since construction is site specific, it is very important to investigate the subsurface conditions which often influence the design of a facility as well as its foundation. The uncertainty in the design is particularly acute in geotechnical engineering so that the assignment of risks in this area should be a major concern. Since the degree of uncertainty in a project is perceived differently by different parties involved in a project, the assignment of unquantifiable risks arising from numerous unknowns to the owner, engineer and contractor is inherently difficult. It is no wonder that courts or arbitrators are often asked to distribute equitably a risk to parties who do not perceive the same risks and do not want to assume a disproportionate share of such risks.

#### Example 3-10: Design of a tie-back retaining wall [15]

This example describes the use of a tie-back retaining wall built in the 1960's when such construction was uncommon and posed a considerable risk. The engineer designing it and the owner were aware of the risk because of potentially extreme financial losses from both remedial and litigation costs in the event that the retaining wall failed and permitted a failure of the slope. But the benefits were perceived as being worth the risk--benefits to the owner in terms of both lower cost and shorter schedule, and benefits to the engineer in terms of professional satisfaction in meeting the owner's needs and solving what appeared to be an insurmountable technical problem.

The tie-back retaining wall was designed to permit a cut in a hillside to provide additional space for the expansion of a steel-making facility. Figure 3-9 shows a cross section of the original hillside located in an urban area. Numerous residential dwellings were located on top of the hill which would have been prohibitively costly or perhaps impossible to remove to permit regrading of the hillside to push back the toe of the slope. The only realistic way of accomplishing the desired goal was to attempt to remove the toe of the existing slope and use a tie-back retaining wall to stabilize the slope as shown in Figure 3-10.

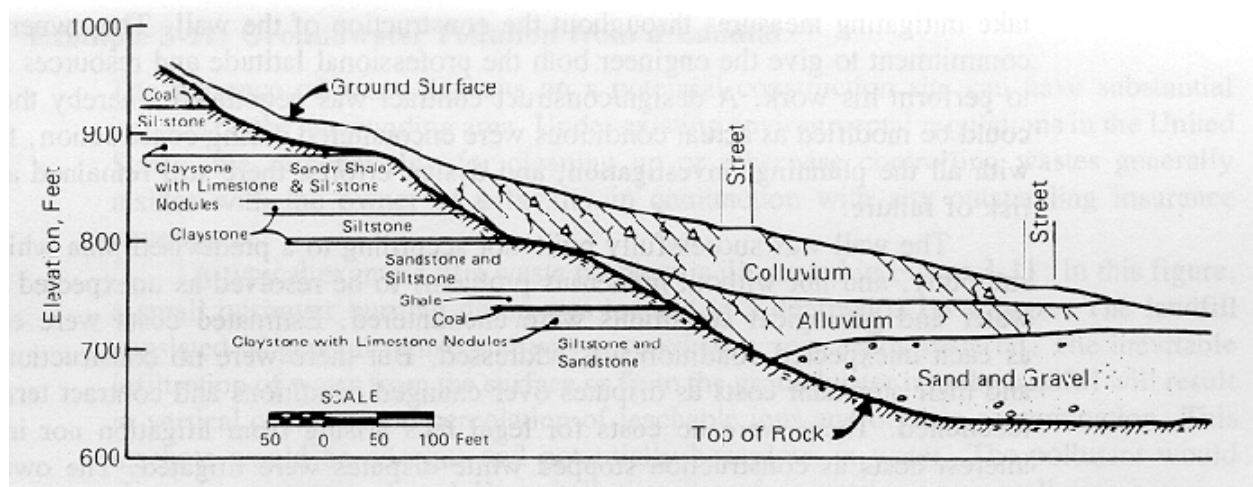
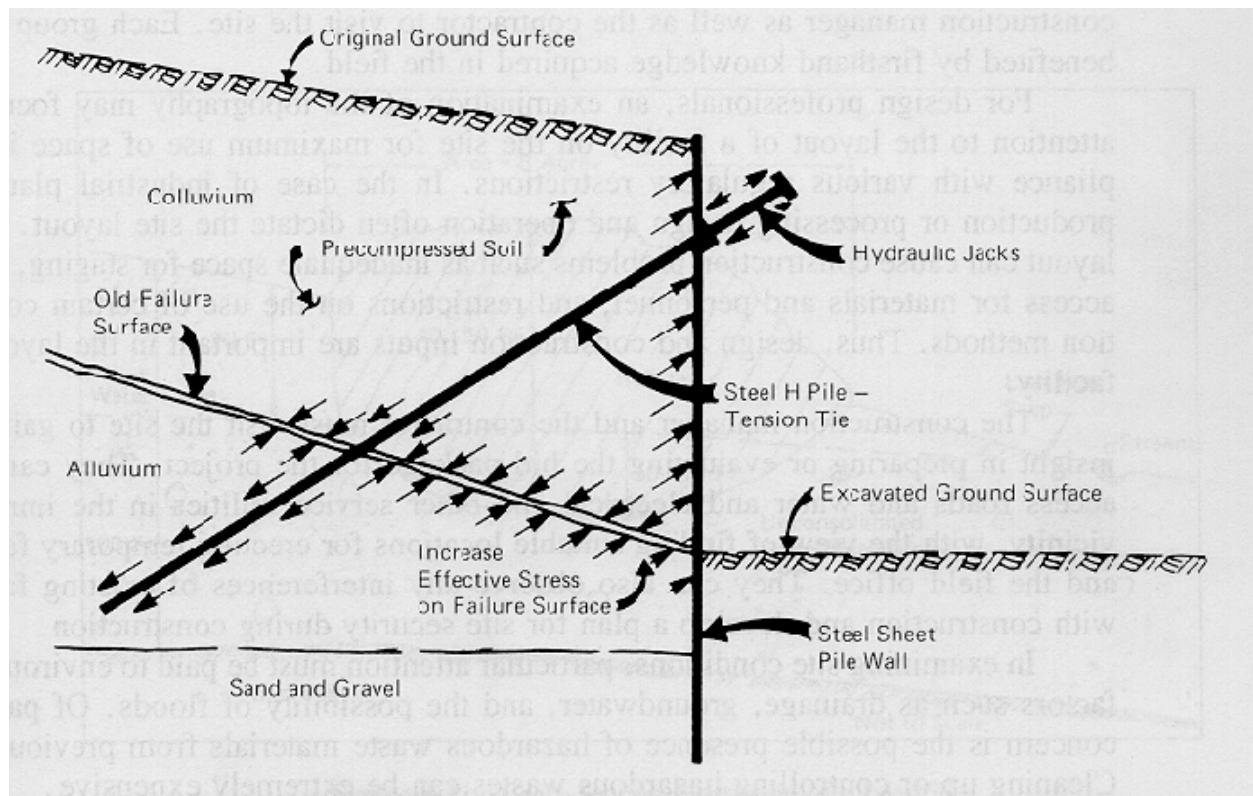

Figure 3-9: Typical Cross Section of Hillside Adjoining Site



**Figure 3-10:** Schematic Section of Anchored Steel Sheet Pile Retaining Wall

A commitment was made by both the owner and the engineer to accomplish what was a common goal. The engineer made a commitment to design and construct the wall in a manner which permitted a real-time evaluation of problems and the ability to take mitigating measures throughout the construction of the wall. The owner made a commitment to give the engineer both the professional latitude and resources required to perform his work. A design-construct contract was negotiated whereby the design could be modified as actual conditions were encountered during construction. But even with all of the planning, investigation and design efforts, there still remained a sizable risk of failure.

The wall was successfully built--not according to a pre-devised plan which went smoothly, and not without numerous problems to be resolved as unexpected groundwater and geological conditions were encountered. Estimated costs were exceeded as each unexpected condition was addressed. But there were no construction delays and their attendant costs as disputes over changed conditions and contract terms were reconciled. There were no costs for legal fees arising from litigation nor increased interest costs as construction stopped while disputes were litigated. The owner paid more than was estimated, but not more than was necessary and not as much as if he had to acquire the property at the top of the hill to regrade the slope. In addition, the owner was able to attain the desired facility expansion in far less time than by any other method.

As a result of the success of this experience and others, the use of tie-back retaining walls has become a routine practice.

### 3.8 Construction Site Environment

While the general information about the construction site is usually available at the planning stage of a project, it is important for the design professionals and construction manager as well as the contractor to visit the site. Each group will be benefited by first-hand knowledge acquired in the field.

For design professionals, an examination of the topography may focus their attention to the layout of a facility on

the site for maximum use of space in compliance with various regulatory restrictions. In the case of industrial plants, the production or processing design and operation often dictate the site layout. A poor layout can cause construction problems such as inadequate space for staging, limited access for materials and personnel, and restrictions on the use of certain construction methods. Thus, design and construction inputs are important in the layout of a facility.

The construction manager and the contractor must visit the site to gain some insight in preparing or evaluating the bid package for the project. They can verify access roads and water, electrical and other service utilities in the immediate vicinity, with the view of finding suitable locations for erecting temporary facilities and the field office. They can also observe any interferences of existing facilities with construction and develop a plan for site security during construction.

In examining site conditions, particular attention must be paid to environmental factors such as drainage, groundwater and the possibility of floods. Of particular concern is the possible presence of hazardous waste materials from previous uses. Cleaning up or controlling hazardous wastes can be extremely expensive.

### Example 3-11: Groundwater Pollution from a Landfill [16]

The presence of waste deposits on a potential construction site can have substantial impacts on the surrounding area. Under existing environmental regulations in the United States, the responsibility for cleaning up or otherwise controlling wastes generally resides with the owner of a facility in conjunction with any outstanding insurance coverage.

A typical example of a waste problem is illustrated in Figure 3-11. In this figure, a small pushover burning dump was located in a depression on a slope. The landfill consisted of general refuse and was covered by a very sandy material. The inevitable infiltration of water from the surface or from the groundwater into the landfill will result in vertical or horizontal percolation of leachable ions and organic contamination. This leachate would be odorous and potentially hazardous in water. The pollutant would show up as seepage downhill, as pollution in surface streams, or as pollution entering the regional groundwater.

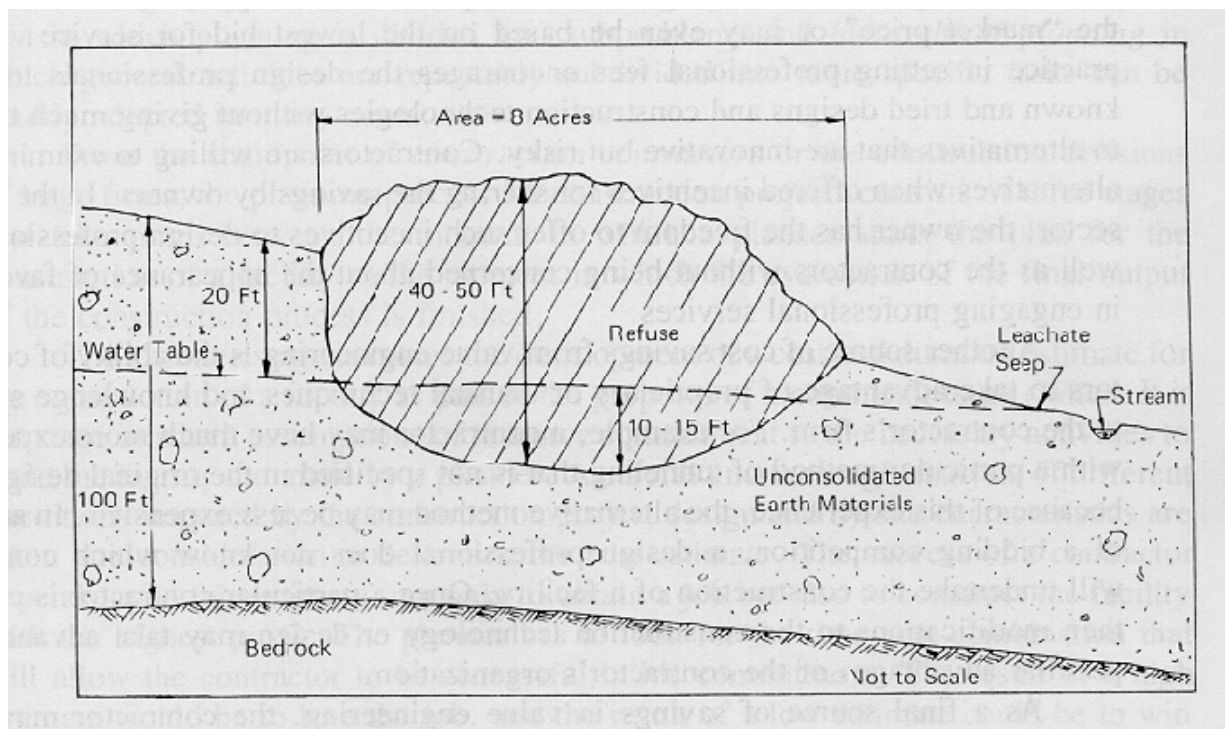

Figure 3-11: Cross-Section Illustration of a Landfill

Before new construction could proceed, this landfill site would have to be controlled or removed. Typical control methods might involve:

- Surface water control measures, such as contour grading or surface sealing.
- Passive groundwater control techniques such as underground barriers between the groundwater and the landfill.
- Plume management procedures such as pumping water from surrounding wells.
- Chemical immobilization techniques such as applying surface seals or chemical injections.
- Excavation and reburial of the landfill requiring the availability of an engineered and environmentally sound landfill.

The excavation and reburial of even a small landfill site can be very expensive. For example, the estimated reburial cost for a landfill like that shown in Figure 3-11 was in excess of \$ 4 million in 1978.

### 3.9 Value Engineering

Value engineering may be broadly defined as an organized approach in identifying unnecessary costs in design and construction and in soliciting or proposing alternative design or construction technology to reduce costs without sacrificing quality or performance requirements. It usually involves the steps of gathering pertinent information, searching for creative ideas, evaluating the promising alternatives, and proposing a more cost effective alternative. This approach is usually applied at the beginning of the construction phase of the project life cycle.

The use of value engineering in the public sector of construction has been fostered by legislation and government regulation, but the approach has not been widely adopted in the private sector of construction. One explanation may lie in the difference in practice of engineering design services in the public and private sectors. In the public sector, the fee for design services is tightly monitored against the "market price," or may even be based on the lowest bid for service. Such a practice in setting professional fees encourages the design professionals to adopt known and tried designs and construction technologies without giving much thought to alternatives that are innovative but risky. Contractors are willing to examine such alternatives when offered incentives for sharing the savings by owners. In the private sector, the owner has the freedom to offer such incentives to design professionals as well as the contractors without being concerned about the appearance of favoritism in engaging professional services.

Another source of cost savings from value engineering is the ability of contractors to take advantage of proprietary or unusual techniques and knowledge specific to the contractor's firm. For example, a contractor may have much more experience with a particular method of tunneling that is not specified in the original design and, because of this experience, the alternative method may be less expensive. In advance of a bidding competition, a design professional does not know which contractor will undertake the construction of a facility. Once a particular contractor is chosen, then modifications to the construction technology or design may take advantage of peculiar advantages of the contractor's organization.

As a final source of savings in value engineering, the contractor may offer genuine new design or construction insights which have escaped the attention of the design professional even if the latter is not restrained by the fee structure to explore more alternatives. If the expertise of the contractor can be utilized, of course, the best time to employ it is during the planning and design phase of the project life cycle. That is why professional construction management or integrated design/construction are often preferred by private owners.

### 3.10 Construction Planning

The development of a construction plan is very much analogous to the development of a good facility design. The planner must weigh the costs and reliability of different options while at the same time insuring technical feasibility. Construction planning is more difficult in some ways since the building process is dynamic as the site and the physical facility change over time as construction proceeds. On the other hand, construction operations tend to be fairly standard from one project to another, whereas structural or foundation details might differ considerably from one facility to another.

Forming a good construction plan is an exceptionally challenging problem. There are numerous possible plans available for any given project. While past experience is a good guide to construction planning, each project is likely to have special problems or opportunities that may require considerable ingenuity and creativity to overcome or exploit. Unfortunately, it is quite difficult to provide direct guidance concerning general procedures or strategies to form good plans in all circumstances. There are some recommendations or issues that can be addressed to describe the *characteristics* of good plans, but this does not necessarily tell a planner how to discover a good plan. However, as in the design process, strategies of *decomposition* in which planning is divided into subproblems and *hierarchical planning* in which general activities are repeatably subdivided into more specific tasks can be readily adopted in many cases.

From the standpoint of *construction contractors* or the construction divisions of large firms, the planning process for construction projects consists of three stages that take place between the moment in which a planner starts the plan for the construction of a facility to the moment in which the evaluation of the final output of the construction process is finished.

The *estimate* stage involves the development of a cost and duration estimate for the construction of a facility as part of the proposal of a contractor to an owner. It is the stage in which assumptions of resource commitment to the necessary activities to build the facility are made by a planner. A careful and thorough analysis of different conditions imposed by the construction project design and by site characteristics are taken into consideration to determine the best estimate. The success of a contractor depends upon this estimate, not only to obtain a job but also to construct the facility with the highest profit. The planner has to look for the time-cost combination that will allow the contractor to be successful in his commitment. The result of a high estimate would be to lose the job, and the result of a low estimate could be to win the job, but to lose money in the construction process. When changes are done, they should improve the estimate, taking into account not only present effects, but also future outcomes of succeeding activities. It is very seldom the case in which the output of the construction process exactly echoes the estimate offered to the owner.

In the *monitoring and control stage* of the construction process, the construction manager has to keep constant track of both activities' durations and ongoing costs. It is misleading to think that if the construction of the facility is on schedule or ahead of schedule, the cost will also be on the estimate or below the estimate, especially if several changes are made. Constant evaluation is necessary until the construction of the facility is complete. When work is finished in the construction process, and information about it is provided to the planner, the third stage of the planning process can begin.

The *evaluation* stage is the one in which results of the construction process are matched against the estimate. A planner deals with this uncertainty during the estimate stage. Only when the outcome of the construction process is known is he/she able to evaluate the validity of the estimate. It is in this last stage of the planning process that he or she determines if the assumptions were correct. If they were not or if new constraints emerge, he/she should introduce corresponding adjustments in future planning.

### **3.11 Industrialized Construction and Pre-fabrication**

Another approach to construction innovation is to apply the principles and organizational solutions adopted for manufacturing. Industrialized construction and pre-fabrication would involve transferring a significant portion of construction operations from the construction site to more or less remote sites where individual components of buildings and structures are produced. Elements of facilities could be prefabricated off the erection site and assembled by cranes and other lifting machinery.

There are a wide variety and degrees of introducing greater industrialization to the construction process. Many components of constructed facilities have always been manufactured, such as air conditioning units. Lumber, piping and other individual components are manufactured to standard sizes. Even temporary items such as forms for concrete can be assembled off-site and transported for use. Reinforcing bars for concrete can also be pre-cut and shaped to the desired configuration in a manufacturing plant or in an automated plant located proximate to a construction site.

A major problem in extending the use of pre-fabricated units is the lack of standardization for systems and building

regulations.[\[17\]](#) While designers have long adopted standard sizes for individual components in designs, the adoption of standardized sub-assemblies is rarer. Without standardization, the achievement of a large market and scale economies of production in manufacturing may be impossible. An innovative and more thorough industrialization of the entire building process may be a primary source of construction cost savings in the future.

### **Example 3-12: Planning of pre-fabrication**

When might pre-fabricated components be used in preference to components assembled on a construction site? A straightforward answer is to use pre-fabricated components whenever their cost, including transportation, is less than the cost of assembly on site. As an example, forms for concrete panels might be transported to a construction site with reinforcing bars already built in, necessary coatings applied to the forms, and even special features such as electrical conduit already installed in the form. In some cases, it might be less expensive to pre-fabricate and transport the entire concrete panel to a manufacturing site. In contrast, traditional construction practice would be to assemble all the different features of the panel on-site. The relevant costs of these alternatives could be assessed during construction planning to determine the lowest cost alternative.

In addition to the consideration of direct costs, a construction planner should also consider some other aspects of this technology choice. First, the planner must insure that pre-fabricated components will satisfy the *relevant building codes and regulations*. Second, the *relative quality* of traditional versus pre-fabricated components as experienced in the final facility should be considered. Finally, the *availability of components* at the required time during the construction process should also be considered.

### **Example 3-13: Impacts of building codes[\[18\]](#)**

Building codes originated as a part of the building regulatory process for the safety and general welfare of the public. The source of all authority to enact building codes is based on the police power of the state which may be delegated by the state legislature to local government units. Consequently, about 8,000 localities having their own building codes, either by following a national model code or developing a local code. The lack of uniformity of building codes may be attributed to a variety of reasons:

- Neighboring municipalities may adopt different national models as the basis for local regulation.
- Periodic revisions of national codes may not be adopted by local authorities before the lapse of several years.
- Municipalities may explicitly decline to adopt specific provisions of national model codes or may use their own variants of key provisions.
- Local authorities may differ in interpretation of the same language in national model codes.

The lack of uniformity in building codes has serious impact on design and construction as well as the regulatory process for buildings. Among the significant factors are:

- Delay in the diffusion of new building innovations which may take a long time to find their ways to be incorporated in building codes.
- Discouragement to new production organizations, such as industrialized construction and prefabrication.
- Duplication of administrative cost of public agencies and compliance cost incurred by private firms.

## **3.12 Computer-Aided Engineering**

In the past twenty years, the computer has become an essential tool in engineering, design, and accounting. The innovative designs of complicated facilities cited in the previous sections would be impossible without the aid of computer based analysis tools. By using general purpose analysis programs to test alternative designs of complex structures such as petrochemical plants, engineers are able to greatly improve initial designs. General purpose



accounting systems are also available and adopted in organizations to perform routine bookkeeping and financial accounting chores. These applications exploit the capability for computers to perform numerical calculations in a pre-programmed fashion rapidly, inexpensively and accurately.

Despite these advances, the computer is often used as only an incidental tool in the design, construction and project management processes. However, new capabilities, systems and application programs are rapidly being adopted. These are motivated in part by the remarkable improvement in computer hardware capability, the introduction of the Internet, and an extraordinary decline in cost. New concepts in computer design and in software are also contributing. For example, the introduction of personal computers using microcircuitry has encouraged the adoption of interactive programs because of the low cost and considerable capability of the computer hardware. Personal computers available for a thousand dollars in 1995 have essentially the same capability as expensive mainframe computer systems of fifteen years earlier.

Computer graphics provide another pertinent example of a potentially revolutionary mechanism for design and communication. Graphical representations of both the physical and work activities on projects have been essential tools in the construction industry for decades. However, manual drafting of blueprints, plans and other diagrams is laborious and expensive. Stand alone, computer aided drafting equipment has proved to be less expensive and fully capable of producing the requiring drawings. More significantly, the geometric information required for producing desired drawings might also be used as a database for computer aided design and computer integrated construction. Components of facilities can be represented as three dimensional computer based *solid models* for this purpose. Geometric information forms only one component of integrated design databases in which the computer can assure consistency, completeness and compliance with relevant specifications and constraints. Several approaches to integrated computer aided engineering environments of this type have already been attempted. [19]

Computers are also being applied more and more extensively to non-analytical and non-numerical tasks. For example, computer based specification writing assistants are used to rapidly assemble sets of standard specifications or to insert special clauses in the documentation of facility designs. As another example, computerized transfer of information provides a means to avoid laborious and error-prone transcription of project information. While most of the traditional applications and research in computer aids have emphasized numerical calculations, the use of computers will rapidly shift towards the more prevalent and difficult problems of planning, communication, design and management.

Knowledge based systems represent a prominent example of new software approaches applicable to project management. These systems originally emerged from research in artificial intelligence in which human cognitive processes were modeled. In limited problem domains such as equipment configuration or process control, knowledge based systems have been demonstrated to approach or surpass the performance of human experts. The programs are marked by a separation between the reasoning or "inference" engine program and the representation of domain specific knowledge. As a result, system developers need not specify complete problem solving strategies (or algorithms) for particular problems. This characteristic of knowledge based systems make them particularly useful in the ill-structured domains of design and project management. Chapter 15 will discuss knowledge based systems in greater detail.

Computer program assistants will soon become ubiquitous in virtually all project management organizations. The challenge for managers is to use the new tools in an effective fashion. Computer intensive work environments should be structured to aid and to amplify the capabilities of managers rather than to divert attention from real problems such as worker motivation.

### 3.13 Pre-Project Planning

Even before design and construction processes begin, there is a stage of "pre-project planning" that can be critical for project success. In this process, the project scope is established. Since construction and design professionals are often not involved in this project scope stage, the terminology of describing this as a "pre-project" process has arisen. From the owner's perspective, defining the project scope is just another phase in the process of acquiring a constructed facility.

The definition of a project scope typically involves developing project alternatives at a conceptual level, analyzing

project risks and economic payoff, developing a financial plan, making a decision to proceed (or not), and deciding upon the project organization and control plan. The next few chapters will examine these different problems at some length.

The danger of poor project definition comes from escalating costs (as new items are added) or, in the extreme, project failure. A good definition of scope allows all the parties in the project to understand what is needed and to work towards meeting those needs.

**Example 3-14: The Project Definition Rating Index (PDRI) for Building Projects** The Construction Industry Institute has developed rating indexes for different types of projects to assess the adequacy of project scope definitions.<sup>[20]</sup> These are intended to reflect best practices in the building industry and provides a checklist for recommended activities and milestones to define a project scope. The rating index is a weighted sum of scores received for a variety of items on the scope definition checklist. Each item in the checklist is rated as "not applicable" (0), "complete definition" (1), "minor deficiencies" (2), "some deficiencies" (3), "major deficiencies" (4) or "incomplete or poor definition" (5). Lower scores in these categories are preferable. Some items in the checklist include:

- Business Strategy for building use, justification, plan, economic analysis, facility requirements, expansion/alteration consideration, site selection issues and project objectives.
- Owner Philosophy with regard to reliability, maintenance, operation and design.
- Project Requirements for value engineering, design, existing facility, scope of work review, schedule and budget.
- Site Information including applicable regulatory reporting and permits requirements.
- Building Programming including room by room definitions for use, finishes, interior requirements and hvac (heating, ventilating and air conditioning).
- Design Parameters including all components and a constructability analysis.
- Equipment including inventory, locations and utility requirements.

### 3.14 References

1. Au, T. and P. Christiano, *Structural Analysis*, Prentice-Hall, Inc., Englewood Cliffs, NJ, 1987.
2. Building Research Advisory Board, *Exploratory Study on Responsibility, Liability and Accountability for Risks in Construction*, National Academy of Sciences, Washington, D.C., 1978.
3. Drucker, P.F., *Innovation and Entrepreneurship: Practice and Principles*, Harper and Row, New York, 1985.
4. Gaylord, E., and C. Gaylord (Editors), *Structural Engineering Handbook*, McGraw-Hill Book Co., New York, 1979.
5. Levitt, R.E., R.D. Logcher and N.H. Quaddumi, "Impact of Owner-Engineer Risk Sharing on Design Conservatism," *ASCE Journal of Professional Issues in Engineering*, Vol. 110, 1984, pp. 157-167.
6. Simon, H.A., *The Science of the Artificial*, Second Edition, MIT Press, Cambridge, MA, 1981.
7. Tatum, C.B., "Innovation on the Construction Project: A Process View," *Project Management Journal*, Vol. 18, No. 5, 1987, pp. 57-67.
8. Pre-Project Planning Research Team, *Pre-Project Planning Handbook* Construction Industry Institute, Publication 39-2, April 1995.

### 3.15 Footnotes

1. See "ASCE Unveils Quality Manual", *ENR*, November 5, 1987, p. 14) [Back](#)
2. See V. Fairweather, "Milan's Model Metro", *Civil Engineering*, December 1987, pp. 40-43. [Back](#)
3. See T.Y. Lin and B.G. Gerwick, Jr. "Design of Long Span Concrete Bridges with Special References to Prestressing, Precasting, Structural Behavior and Economics," ACI Publication SP-23, First International Symposium, 1969, pp. 693-704 [Back](#)
4. See Linnhoff, B., D.W. Townsend, D. Boland, G.F. Hewitt, B.E.A. Thomas, A.R. Guy, and R.H. Marsland, *User Guide on Process Integration for the Efficient Use of Energy*, Institution of Chemical Engineers, Rugby, Warks., England, 1982. [Back](#)
5. "More Construction for the Money," *Summary Report of the Construction Industry Cost Effectiveness Project*,

The Business Roundtable, New York, 1983, pg. 30. [Back](#)

6. See "The Quiet Revolution i

<a href="#">Go Up to Table of Contents</a>	
<a href="#">Go To Chapter 3 (The Design and Construction Process)</a>	<a href="#">Go To Chapter 5 (Cost Estimation)</a>
<i>Labor, Material and Equipment Utilization</i>	
<a href="#">Historical Perspective</a>	
<a href="#">Labor Productivity</a>	
<a href="#">Factors Affecting Job-Site Productivity</a>	
<a href="#">Labor Relations in Construction</a>	
<a href="#">Problems in Collective Bargaining</a>	
<a href="#">Materials Management</a>	
<a href="#">Material Procurement and Delivery</a>	
<a href="#">Inventory Control</a>	
<a href="#">Tradeoffs of Costs in Materials Management.</a>	
<a href="#">Construction Equipment</a>	
<a href="#">Choice of Equipment and Standard Production Rates</a>	
<a href="#">Construction Processes</a>	
<a href="#">Queues and Resource Bottlenecks</a>	
<a href="#">References</a>	
<a href="#">Problems</a>	
<a href="#">Footnotes</a>	

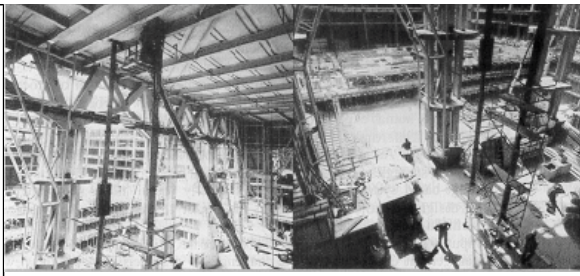

[http://pmbook.ce.cmu.edu/04\\_Labor,\\_Material,\\_And\\_Equipment\\_Utilization.html](http://pmbook.ce.cmu.edu/04_Labor,_Material,_And_Equipment_Utilization.html)

## 4. Labor, Material and Equipment Utilization

### 4.1 Historical Perspective

Good project management in construction must vigorously pursue the efficient utilization of labor, material and equipment. Improvement of labor productivity should be a major and continual concern of those who are responsible for cost control of constructed facilities. Material handling, which includes procurement, inventory, shop fabrication and field servicing, requires special attention for cost reduction. The use of new equipment and innovative methods has made possible wholesale changes in construction technologies in recent decades. Organizations which do not recognize the impact of various innovations and have not adapted to changing environments have justifiably been forced out of the mainstream of construction activities.

Observing the trends in construction technology presents a very mixed and ambiguous picture. On the one hand, many of the techniques and materials used for construction are essentially unchanged since the introduction of mechanization in the early part of the twentieth century. For example, a history of the Panama Canal construction from 1904 to 1914 argues that:

[T]he work could not have done any faster or more efficiently in our day, despite all technological and mechanical advances in the time since, the reason being that no present system could possibly carry the spoil away any faster or more efficiently than the system employed. No motor trucks were used in the digging of the canal; everything ran on rails. And because of the mud and rain, no other method would have worked half so well. [1]

In contrast to this view of one large project, one may also point to the continual change and improvements occurring in traditional materials and techniques. Bricklaying provides a good example of such changes:

Bricklaying...is said not to have changed in thousands of years; perhaps in the literal placing of brick on brick it has not. But masonry technology has changed a great deal. Motorized wheelbarrows and mortar mixers, sophisticated scaffolding systems, and forklift trucks now assist the bricklayer. New epoxy mortars give stronger adhesion between bricks. Mortar additives and cold-weather protection eliminate winter shutdowns. [2]

Add to this list of existing innovations the possibility of robotic bricklaying; automated prototypes for masonry construction already exist. Technical change is certainly occurring in construction, although it may occur at a slower rate than in other sectors of the economy.

The United States construction industry often points to factors which cannot be controlled by the industry as a major explanatory factor in cost increases and lack of technical innovation. These include the imposition of restrictions for protection of the environment and historical districts, requirements for community participation in major construction projects, labor laws which allow union strikes to become a source of disruption, regulatory policies including building codes and zoning ordinances, and tax laws which inhibit construction abroad. However, the construction industry should bear a large share of blame for not realizing earlier that the technological edge held by the large U.S. construction firms has eroded in face of stiff foreign competition. Many past practices, which were tolerated when U.S. contractors had a technological lead, must now be changed in the face of stiff competition. Otherwise, the U.S. construction industry will continue to find itself in trouble.

With a strong technological base, there is no reason why the construction industry cannot catch up and reassert itself to meet competition wherever it may be. Individual design and/or construction firms must explore new ways to improve productivity for the future. Of course, operational planning for construction projects is still important, but such tactical planning has limitations and may soon reach the point of diminishing return because much that can be wrung out of the existing practices have already been tried. What is needed the most is strategic

planning to usher in a revolution which can improve productivity by an order of magnitude or more. Strategic planning should look at opportunities and ask whether there are potential options along which new goals may be sought on the basis of existing resources. No one can be certain about the success of various development options for the design professions and the construction industry. However, with the availability of today's high technology, some options have good potential of success because of the social and economic necessity which will eventually push barriers aside. Ultimately, decisions for action, not plans, will dictate future outcomes.

[Back to top](#)

## 4.2 Labor Productivity

Productivity in construction is often broadly defined as output per labor hour. Since labor constitutes a large part of the construction cost and the quantity of labor hours in performing a task in construction is more susceptible to the influence of management than are materials or capital, this productivity measure is often referred to as *labor productivity*. However, it is important to note that labor productivity is a measure of the overall effectiveness of an operating system in utilizing labor, equipment and capital to convert labor efforts into useful output, and is not a measure of the capabilities of labor alone. For example, by investing in a piece of new equipment to perform certain tasks in construction, output may be increased for the same number of labor hours, thus resulting in higher labor productivity.

Construction output may be expressed in terms of functional units or constant dollars. In the former case, labor productivity is associated with units of product per labor hour, such as cubic yards of concrete placed per hour or miles of highway paved per hour. In the latter case, labor productivity is identified with value of construction (in constant dollars) per labor hour. The value of construction in this regard is not measured by the benefit of constructed facilities, but by construction cost. Labor productivity measured in this way requires considerable care in interpretation. For example, wage rates in construction have been declining in the US during the period 1970 to 1990, and since wages are an important component in construction costs, the value of construction put in place per hour of work will decline as a result, suggesting lower productivity.

### Productivity at the Job Site

Contractors and owners are often concerned with the labor activity at job sites. For this purpose, it is convenient to express labor productivity as functional units per labor hour for each type of construction task. However, even for such specific purposes, different levels of measure may be used. For example, cubic yards of concrete placed per hour is a lower level of measure than miles of highway paved per hour. Lower-level measures are more useful for monitoring individual activities, while higher-level measures may be more convenient for developing industry-wide standards of performance.

While each contractor or owner is free to use its own system to measure labor productivity at a site, it is a good practice to set up a system which can be used to track productivity trends over time and in varied locations. Considerable efforts are required to collect information regionally or nationally over a number of years to produce such results. The productivity indices compiled from statistical data should include parameters such as the performance of major crafts, effects of project size, type and location, and other major project influences.

In order to develop industry-wide standards of performance, there must be a general agreement on the measures to be useful for compiling data. Then, the job site productivity data collected by various contractors and owners can be correlated and analyzed to develop certain measures for each of the major segment of the construction industry. Thus, a contractor or owner can compare its performance with that of the industry average.

### Productivity in the Construction Industry

Because of the diversity of the construction industry, a single index for the entire industry is neither meaningful nor reliable. Productivity indices may be developed for major segments of the construction industry nationwide if reliable statistical data can be obtained for separate industrial segments. For this general type of productivity measure, it is more convenient to express labor productivity as constant dollars per labor hours since dollar values are more easily aggregated from a large amount of data collected from different sources. The use of constant dollars allows meaningful approximations of the changes in construction output from one year to another when price deflators are applied to current dollars to obtain the corresponding values in constant dollars. However, since most construction price deflators are obtained from a combination of price indices for material and labor inputs, they reflect only the change of price levels and do not capture any savings arising from improved labor productivity. Such deflators tend to overstate increases in construction costs over a long period of time, and consequently understate the physical volume or value of construction work in years subsequent to the base year for the indices.

[Back to top](#)

## 4.3 Factors Affecting Job-Site Productivity

Job-site productivity is influenced by many factors which can be characterized either as labor characteristics, project work conditions or as non-productive activities. The labor characteristics include:

- age, skill and experience of workforce
- leadership and motivation of workforce

The project work conditions include among other factors:

- Job size and complexity.
- Job site accessibility.
- Labor availability.
- Equipment utilization.
- Contractual agreements.
- Local climate.
- Local cultural characteristics, particularly in foreign operations.

The non-productive activities associated with a project may or may not be paid by the owner, but they nevertheless take up potential labor resources which can otherwise be directed to the project. The non-productive activities include among other factors:

- Indirect labor required to maintain the progress of the project
- Rework for correcting unsatisfactory work
- Temporary work stoppage due to inclement weather or material shortage
- Time off for union activities
- Absentee time, including late start and early quits
- Non-working holidays
- Strikes

Each category of factors affects the productive labor available to a project as well as the on-site labor efficiency.

### Labor Characteristics

Performance analysis is a common tool for assessing worker quality and contribution. Factors that might be evaluated include:

- Quality of Work - caliber of work produced or accomplished.
- Quantity of Work - volume of acceptable work
- Job Knowledge - demonstrated knowledge of requirements, methods, techniques and skills involved in doing the job and in applying these to increase productivity.
- Related Work Knowledge - knowledge of effects of work upon other areas and knowledge of related areas which have influence on assigned work.
- Judgment - soundness of conclusions, decisions and actions.
- Initiative - ability to take effective action without being told.
- Resource Utilization - ability to delineate project needs and locate, plan and effectively use all resources available.
- Dependability - reliability in assuming and carrying out commitments and obligations.
- Analytical Ability - effectiveness in thinking through a problem and reaching sound conclusions.
- Communicative Ability - effectiveness in using oral and written communications and in keeping subordinates, associates, superiors and others adequately informed.
- Interpersonal Skills - effectiveness in relating in an appropriate and productive manner to others.
- Ability to Work Under Pressure - ability to meet tight deadlines and adapt to changes.
- Security Sensitivity - ability to handle confidential information appropriately and to exercise care in safeguarding sensitive information.
- Safety Consciousness - has knowledge of good safety practices and demonstrates awareness of own personal safety and the safety of others.
- Profit and Cost Sensitivity - ability to seek out, generate and implement profit-making ideas.
- Planning Effectiveness - ability to anticipate needs, forecast conditions, set goals and standards, plan and schedule work and measure results.
- Leadership - ability to develop in others the willingness and desire to work towards common objectives.
- Delegating - effectiveness in delegating work appropriately.
- Development People - ability to select, train and appraise personnel, set standards of performance, and provide motivation to grow in their capacity.
- Diversity (Equal Employment Opportunity) - ability to be sensitive to the needs of minorities, females and other protected groups and to demonstrate affirmative action in responding to these needs.

These different factors could each be assessed on a three point scale: (1) recognized strength, (2) meets expectations, (3) area needing improvement. Examples of work performance in these areas might also be provided.

### Project Work Conditions

Job-site labor productivity can be estimated either for each craft (carpenter, bricklayer, etc.) or each type of construction (residential housing, processing plant, etc.) under a specific set of work conditions. A *base labor productivity* may be defined for a set of work conditions specified by the owner or contractor who wishes to observe and measure the labor performance over a period of time under such conditions. A *labor productivity index* may then be defined as the ratio of the job-site labor productivity under a different set of work conditions to the base labor productivity, and is a measure of the relative labor efficiency of a project under this new set of work conditions.

The effects of various factors related to work conditions on a new project can be estimated in advance, some more accurately than others. For example, for very large construction projects, the labor productivity index tends to decrease as the project size and/or complexity increase because of logistic problems and the "learning" that the work force must undergo before adjusting to the new environment. Job-site accessibility often may reduce the labor productivity index if the workers must perform their jobs in round about ways, such as avoiding

traffic in repaving the highway surface or maintaining the operation of a plant during renovation. Labor availability in the local market is another factor. Shortage of local labor will force the contractor to bring in non-local labor or schedule overtime work or both. In either case, the labor efficiency will be reduced in addition to incurring additional expenses. The degree of equipment utilization and mechanization of a construction project clearly will have direct bearing on job-site labor productivity. The contractual agreements play an important role in the utilization of union or non-union labor, the use of subcontractors and the degree of field supervision, all of which will impact job-site labor productivity. Since on-site construction essentially involves outdoor activities, the local climate will influence the efficiency of workers directly. In foreign operations, the cultural characteristics of the host country should be observed in assessing the labor efficiency.

### Non-Productive Activities

The non-productive activities associated with a project should also be examined in order to examine the *productive labor yield*, which is defined as the ratio of direct labor hours devoted to the completion of a project to the potential labor hours. The direct labor hours are estimated on the basis of the best possible conditions at a job site by excluding all factors which may reduce the productive labor yield. For example, in the repaving of highway surface, the flagmen required to divert traffic represent indirect labor which does not contribute to the labor efficiency of the paving crew if the highway is closed to the traffic. Similarly, for large projects in remote areas, indirect labor may be used to provide housing and infrastructure for the workers hired to supply the direct labor for a project. The labor hours spent on rework to correct unsatisfactory original work represent extra time taken away from potential labor hours. The labor hours related to such activities must be deducted from the potential labor hours in order to obtain the actual productive labor yield.

#### Example 4-1: Effects of job size on productivity

A contractor has established that under a set of "standard" work conditions for building construction, a job requiring 500,000 labor hours is considered standard in determining the base labor productivity. All other factors being the same, the labor productivity index will increase to 1.1 or 110% for a job requiring only 400,000 labor-hours. Assuming that a linear relation exists for the range between jobs requiring 300,000 to 700,000 labor hours as shown in Figure 4-1, determine the labor productivity index for a new job requiring 650,000 labor hours under otherwise the same set of work conditions.



**Figure 4-1:** Illustrative Relationship between Productivity Index and Job Size

The labor productivity index  $I$  for the new job can be obtained by linear interpolation of the available data as follows:

$$I = 1.0 + (1.1 - 1.0) \left( \frac{500,000 - 650,000}{500,000 - 400,000} \right) = 0.85$$

This implies that labor is 15% less productive on the large job than on the standard project.

#### Example 4-2: Productive labor yield [3]

In the construction of an off-shore oil drilling platform, the potential labor hours were found to be  $L = 7.5$  million hours. Of this total, the non-productive activities expressed in thousand labor hours were as follows:

- A = 417 for holidays and strikes
- B = 1,415 for absentees (i.e. vacation, sick time, etc.)
- C = 1,141 for temporary stoppage (i.e. weather, waiting, union activities, etc.)

- D = 1,431 for indirect labor (i.e. building temporary facilities, cleaning up the site, rework to correct errors, etc.)

Determine the productive labor yield after the above factors are taken into consideration.

The percentages of time allocated to various non-productive activities, A, B, C and D are:

$$\frac{A}{L} = \frac{417}{7,500} = 6\%; \quad \frac{B}{L} = \frac{1,415}{7,500} = 19\%$$

$$\frac{C}{L} = \frac{1,141}{7,500} = 15\%; \quad \frac{D}{L} = \frac{1,431}{7,500} = 19\%$$

The total percentage of time X for all non-productive activities is:

$$X = \frac{A+B+C+D}{L} = 6\% + 19\% + 15\% + 19\% = 59\%$$

The productive labor yield, Y, when the given factors for A, B, C and D are considered, is as follows:

$$Y = \frac{L-A-B-C-D}{L} = 100\% - 6\% - 19\% - 15\% - 19\% = 41\%$$

As a result, only 41% of the budgeted labor time was devoted directly to work on the facility.

#### Example 4-3: Utilization of on-site worker's time

An example illustrating the effects of indirect labor requirements which limit productive labor by a typical craftsman on the job site was given by R. Tucker with the following percentages of time allocation: [\[4\]](#)

Productive time	40%
Unproductive time	
Administrative delays	20%
Inefficient work methods	20%
Labor jurisdictions and other work restrictions	15%
Personal time	5%

In this estimate, as much time is spent on productive work as on delays due to management and inefficiencies due to antiquated work methods.

[Back to top](#)

## 4.4 Labor Relations in Construction

The market demand in construction fluctuates greatly, often within short periods and with uneven distributions among geographical regions. Even when the volume of construction is relatively steady, some types of work may decline in importance while other types gain. Under an unstable economic environment, employers in the construction industry place great value on flexibility in hiring and laying off workers as their volumes of work wax and wane. On the other hand, construction workers sense their insecurity under such circumstances and attempt to limit the impacts of changing economic conditions through labor organizations.

There are many crafts in the construction labor forces, but most contractors hire from only a few of these crafts to satisfy their specialized needs. Because of the peculiar characteristics of employment conditions, employers and workers are placed in a more intimate relationship than in many other industries. Labor and management arrangements in the construction industry include both unionized and non-unionized operations which compete for future dominance. Dramatic shifts in unionization can occur. For example, the fraction of trade union members in the construction industry declined from 42% in 1992 to 26% in 2000 in Australia, a 40% decline in 8 years.

### Unionized Construction

The craft unions work with construction contractors using unionized labor through various market institutions such as jurisdiction rules, apprenticeship programs, and the referral system. Craft unions with specific jurisdiction rules for different trades set uniform hourly wage rates for journeymen and offer formal apprenticeship training to provide common and equivalent skill for each trade. Contractors, through the contractors' associations, enter into legally binding collective bargaining agreements with one or more of the craft unions in the construction trades. The system which bind both parties to a collective bargaining agreement is referred to as the "union shop". These agreements obligate a contractor to observe the work jurisdictions of various unions and to hire employees through a union operated referral system commonly



known as the hiring hall.

The referral systems operated by union organizations are required to observe several conditions:

1. All qualified workers reported to the referral system must be made available to the contractor without discrimination on the basis of union membership or other relationship to the union. The "closed shop" which limits referral to union members only is now illegal.
2. The contractor reserves the right to hire or refuse to hire any worker referred by the union on the basis of his or her qualifications.
3. The referral plan must be posted in public, including any priorities of referrals or required qualifications.

While these principles must prevail, referral systems operated by labor organizations differ widely in the construction industry.

Contractors and craft unions must negotiate not only wage rates and working conditions, but also hiring and apprentice training practices. The purpose of trade jurisdiction is to encourage considerable investment in apprentice training on the part of the union so that the contractor will be protected by having only qualified workers perform the job even though such workers are not permanently attached to the contractor and thus may have no sense of security or loyalty. The referral system is often a rapid and dependable source of workers, particularly for a contractor who moves into a new geographical location or starts a new project which has high fluctuations in demand for labor. By and large, the referral system has functioned smoothly in providing qualified workers to contractors, even though some other aspects of union operations are not as well accepted by contractors.

### **Non-Unionized Construction**

In recent years, non-union contractors have entered and prospered in an industry which has a long tradition of unionization. Non-union operations in construction are referred to as "open shops." However, in the absence of collective bargaining agreements, many contractors operate under policies adopted by non-union contractors' associations. This practice is referred to as "merit shop", which follows substantially the same policies and procedures as collective bargaining although under the control of a non-union contractors' association without union participation. Other contractors may choose to be totally "unorganized" by not following either union shop or merit shop practices.

The operations of the merit shop are national in scope, except for the local or state apprenticeship and training plans. The comprehensive plans of the contractors' association apply to all employees and crafts of a contractor regardless of their trades. Under such operations, workers have full rights to move through the nation among member contractors of the association. Thus, the non-union segment of the industry is organized by contractors' associations into an integral part of the construction industry. However, since merit shop workers are employed directly by the construction firms, they have a greater loyalty to the firm, and recognize that their own interest will be affected by the financial health of the firm.

Playing a significant role in the early growth and continued expansion of merit shop construction is the Associated Builders and Contractors association. By 1987, it had a membership of nearly 20,000 contractors and a network of 75 chapters through the nation. Among the merit shop contractors are large construction firms such as Fluor Daniel, Blount International, and Brown & Root Construction. The advantages of merit shops as claimed by its advocates are:

- the ability to manage their own work force
- flexibility in making timely management decisions
- the emphasis on making maximum usage of local labor force
- the emphasis on encouraging individual work advancement through continued development of skills
- the shared interest that management and workers have in seeing an individual firm prosper.

By shouldering the training responsibility for producing skill workers, the merit shop contractors have deflected the most serious complaints of users and labor that used to be raised against the open shop. On the other hand, the use of mixed crews of skilled workers at a job site by merit shop contractors enables them to remove a major source of inefficiencies caused by the exclusive jurisdiction practiced in the union shop, namely the idea that only members of a particular union should be permitted to perform any given task in construction. As a result, merit shop contractors are able to exert a beneficial influence on productivity and cost-effectiveness of construction projects.

The unorganized form of open shop is found primarily in housing construction where a large percentage of workers are characterized as unskilled helpers. The skilled workers in various crafts are developed gradually through informal apprenticeships while serving as helpers. This form of open shop is not expected to expand beyond the type of construction projects in which highly specialized skills are not required.

[Back to top](#)

## **4.5 Problems in Collective Bargaining**

In the organized building trades in North American construction, the primary unit is the international union, which is an association of local unions in the United States and Canada. Although only the international unions have the power to issue or remove charters and to organize or combine local unions, each local union has considerable degrees of autonomy in the conduct of its affairs, including the negotiation of collective bargaining agreements. The business agent of a local union is an elected official who is the most important person in handling the day to day operations on behalf of the union. The contractors' associations representing the employers vary widely in composition and structure, particularly in different geographical regions. In general, local contractors' associations are considerably less well organized than the union with which they deal, but they try to strengthen themselves through affiliation with state and national organizations. Typically, collective bargaining agreements in construction are negotiated between a local union in a single craft and the employers of that craft as represented by a contractors' association, but there are many exceptions to this pattern. For example, a contractor may remain outside the

association and negotiate independently of the union, but it usually cannot obtain a better agreement than the association.

Because of the great variety of bargaining structures in which the union and contractors' organization may choose to stage negotiations, there are many problems arising from jurisdictional disputes and other causes. Given the traditional rivalries among various crafts and the ineffective organization of some of contractors' associations, coupled with the lack of adequate mechanisms for settling disputes, some possible solutions to these problems deserve serious attention: [\[5\]](#)

### Regional Bargaining

Currently, the geographical area in a collective bargaining agreement does not necessarily coincide with the territory of the union and contractors' associations in the negotiations. There are overlapping of jurisdictions as well as territories, which may create successions of contract termination dates for different crafts. Most collective bargaining agreements are negotiated locally, but regional agreements with more comprehensive coverage embracing a number of states have been established. The role of national union negotiators and contractors' representatives in local collective bargaining is limited. The national agreement between international unions and a national contractor normally binds the contractors' association and its bargaining unit. Consequently, the most promising reform lies in the broadening of the geographic region of an agreement in a single trade without overlapping territories or jurisdictions.

### Multicraft Bargaining

The treatment of interrelationships among various craft trades in construction presents one of the most complex issues in the collective bargaining process. Past experience on project agreements has dealt with such issues successfully in that collective bargaining agreements are signed by a group of craft trade unions and a contractor for the duration of a project. Project agreements may reference other agreements on particular points, such as wage rates and fringe benefits, but may set their own working conditions and procedures for settling disputes including a commitment of no-strike and no-lockout. This type of agreement may serve as a starting point for multicraft bargaining on a regional, non-project basis.

### Improvement of Bargaining Performance

Although both sides of the bargaining table are to some degree responsible for the success or failure of negotiation, contractors have often been responsible for the poor performance of collective bargaining in construction in recent years because local contractors' associations are generally less well organized and less professionally staffed than the unions with which they deal. Legislation providing for contractors' association accreditation as an exclusive bargaining agent has now been provided in several provinces in Canada. It provides a government board that could hold hearings and establish an appropriate bargaining unit by geographic region or sector of the industry, on a single-trade or multi-trade basis.

[Back to top](#)

## 4.6 Materials Management

Materials management is an important element in project planning and control. Materials represent a major expense in construction, so minimizing *procurement* or *purchase* costs presents important opportunities for reducing costs. Poor materials management can also result in large and avoidable costs during construction. First, if materials are purchased early, capital may be tied up and interest charges incurred on the excess *inventory* of materials. Even worse, materials may deteriorate during storage or be stolen unless special care is taken. For example, electrical equipment often must be stored in waterproof locations. Second, delays and extra expenses may be incurred if materials required for particular activities are not available. Accordingly, insuring a timely flow of material is an important concern of project managers.

Materials management is not just a concern during the monitoring stage in which construction is taking place. Decisions about material procurement may also be required during the initial planning and scheduling stages. For example, activities can be inserted in the project schedule to represent purchasing of major items such as elevators for buildings. The availability of materials may greatly influence the schedule in projects with a *fast track* or very tight time schedule: sufficient time for obtaining the necessary materials must be allowed. In some case, more expensive suppliers or shippers may be employed to save time.

Materials management is also a problem at the organization level if central purchasing and inventory control is used for standard items. In this case, the various projects undertaken by the organization would present requests to the central purchasing group. In turn, this group would maintain inventories of standard items to reduce the delay in providing material or to obtain lower costs due to bulk purchasing. This organizational materials management problem is analogous to inventory control in any organization facing continuing demand for particular items.

Materials ordering problems lend themselves particularly well to computer based systems to insure the consistency and completeness of the purchasing process. In the manufacturing realm, the use of automated *materials requirements planning* systems is common. In these systems, the master production schedule, inventory records and product component lists are merged to determine what items must be ordered, when they should be ordered, and how much of each item should be ordered in each time period. The heart of these calculations is simple arithmetic: the projected demand for each material item in each period is subtracted from the available inventory. When the inventory becomes too low, a new order is recommended. For items that are non-standard or not kept in inventory, the calculation is even simpler since no inventory must be considered. With a materials requirement system, much of the detailed record keeping is automated and project managers are alerted to purchasing requirements.

**Example 4-4: Examples of benefits for materials management systems.**[\[6\]](#)

From a study of twenty heavy construction sites, the following benefits from the introduction of materials management systems were noted:

- In one project, a 6% reduction in craft labor costs occurred due to the improved availability of materials as needed on site. On other projects, an 8% savings due to reduced delay for materials was estimated.
- A comparison of two projects with and without a materials management system revealed a change in productivity from 1.92 man-hours per unit without a system to 1.14 man-hours per unit with a new system. Again, much of this difference can be attributed to the timely availability of materials.
- Warehouse costs were found to decrease 50% on one project with the introduction of improved inventory management, representing a savings of \$ 92,000. Interest charges for inventory also declined, with one project reporting a cash flow savings of \$ 85,000 from improved materials management.

Against these various benefits, the costs of acquiring and maintaining a materials management system has to be compared. However, management studies suggest that investment in such systems can be quite beneficial.

[Back to top](#)

## 4.7 Material Procurement and Delivery

The main sources of information for feedback and control of material procurement are requisitions, bids and quotations, purchase orders and subcontracts, shipping and receiving documents, and invoices. For projects involving the large scale use of critical resources, the owner may initiate the procurement procedure even before the selection of a constructor in order to avoid shortages and delays. Under ordinary circumstances, the constructor will handle the procurement to shop for materials with the best price/performance characteristics specified by the designer. Some overlapping and rehandling in the procurement process is unavoidable, but it should be minimized to insure timely delivery of the materials in good condition.

The materials for delivery to and from a construction site may be broadly classified as : (1) bulk materials, (2) standard off-the-shelf materials, and (3) fabricated members or units. The process of delivery, including transportation, field storage and installation will be different for these classes of materials. The equipment needed to handle and haul these classes of materials will also be different.

Bulk materials refer to materials in their natural or semi-processed state, such as earthwork to be excavated, wet concrete mix, etc. which are usually encountered in large quantities in construction. Some bulk materials such as earthwork or gravels may be measured in bank (solid in situ) volume. Obviously, the quantities of materials for delivery may be substantially different when expressed in different measures of volume, depending on the characteristics of such materials.

Standard piping and valves are typical examples of standard off-the-shelf materials which are used extensively in the chemical processing industry. Since standard off-the-shelf materials can easily be stockpiled, the delivery process is relatively simple.

Fabricated members such as steel beams and columns for buildings are pre-processed in a shop to simplify the field erection procedures. Welded or bolted connections are attached partially to the members which are cut to precise dimensions for adequate fit. Similarly, steel tanks and pressure vessels are often partly or fully fabricated before shipping to the field. In general, if the work can be done in the shop where working conditions can better be controlled, it is advisable to do so, provided that the fabricated members or units can be shipped to the construction site in a satisfactory manner at a reasonable cost.

As a further step to simplify field assembly, an entire wall panel including plumbing and wiring or even an entire room may be prefabricated and shipped to the site. While the field labor is greatly reduced in such cases, "materials" for delivery are in fact manufactured products with value added by another type of labor. With modern means of transporting construction materials and fabricated units, the percentages of costs on direct labor and materials for a project may change if more prefabricated units are introduced in the construction process.

In the construction industry, materials used by a specific craft are generally handled by craftsmen, not by general labor. Thus, electricians handle electrical materials, pipefitters handle pipe materials, etc. This multiple handling diverts scarce skilled craftsmen and contractor supervision into activities which do not directly contribute to construction. Since contractors are not normally in the freight business, they do not perform the tasks of freight delivery efficiently. All these factors tend to exacerbate the problems of freight delivery for very large projects.

**Example 4-5: Freight delivery for the Alaska Pipeline Project** [\[7\]](#)

The freight delivery system for the Alaska pipeline project was set up to handle 600,000 tons of materials and supplies. This tonnage did not include the pipes which comprised another 500,000 tons and were shipped through a different routing system.

The complexity of this delivery system is illustrated in Figure 4-2. The rectangular boxes denote geographical locations. The points of origin represent plants and factories throughout the US and elsewhere. Some of the materials went to a primary staging point in Seattle and some went directly to Alaska. There were five ports of entry: Valdez, Anchorage, Whittier, Seward and Prudhoe Bay. There was a secondary staging area in Fairbanks and the pipeline itself was divided into six sections. Beyond the Yukon River, there was nothing available but a dirt road for hauling. The amounts of freight in thousands of tons shipped to and from various locations are indicated by the numbers near the network branches (with arrows showing the directions of material

flows) and the modes of transportation are noted above the branches. In each of the locations, the contractor had supervision and construction labor to identify materials, unload from transport, determine where the material was going, repackage if required to split shipments, and then re-load material on outgoing transport.

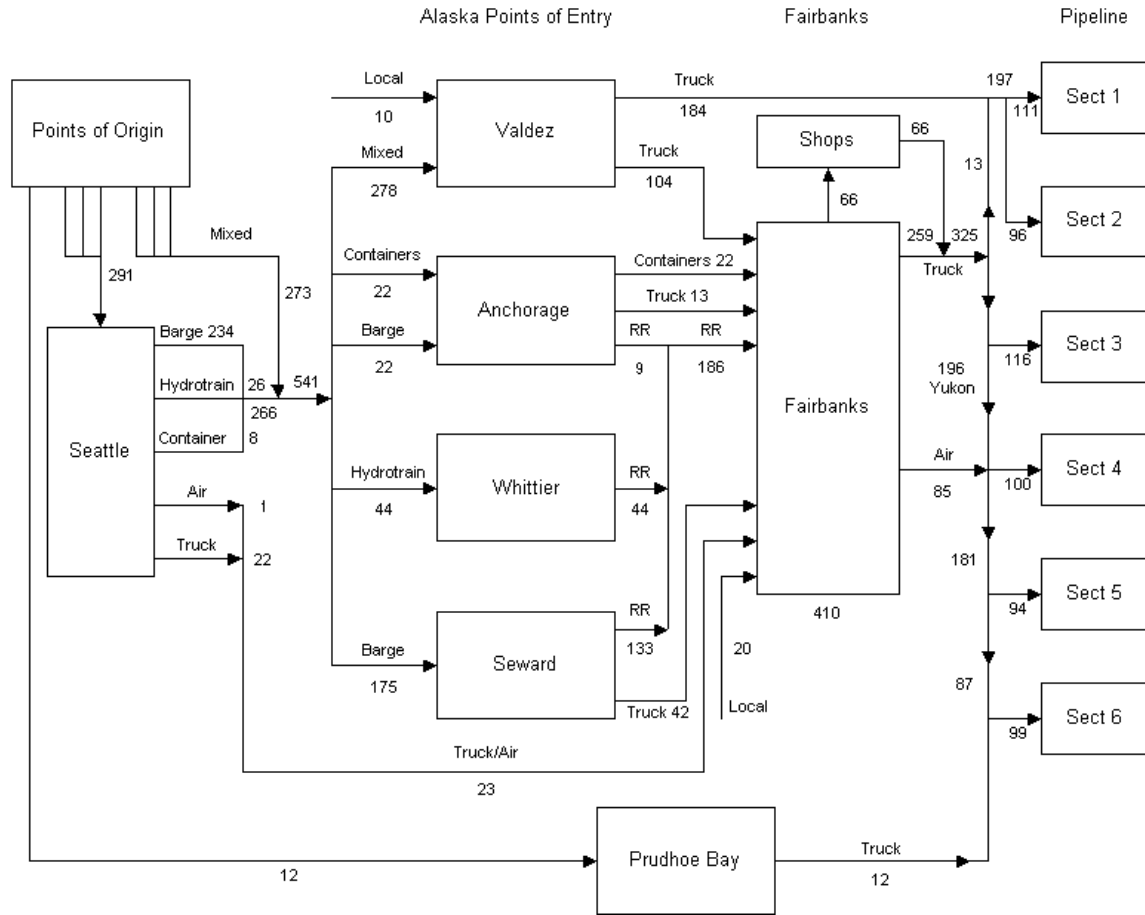

Figure 4-2: Freight Delivery for the Alaska Pipeline Project

**Example 4-6: Process plant equipment procurement [8]**

The procurement and delivery of bulk materials items such as piping electrical and structural elements involves a series of activities if such items are not standard and/or in stock. The times required for various activities in the procurement of such items might be estimated to be as follows:

Activities	Duration (days)	Cumulative Duration
Requisition ready by designer	0	0
Owner approval	5	5
Inquiry issued to vendors	3	8
Vendor quotations received	15	23
Complete bid evaluation by designer	7	30
Owner approval	5	35
Place purchase order	5	40
Receive preliminary shop drawings	10	50
Receive final design drawings	10	60
Fabrication and delivery	60-200	120-260

As a result, this type of equipment procurement will typically require four to nine months. Slippage or contraction in this standard schedule is also possible, based on such factors as the extent to which a fabricator is busy.

[Back to top](#)

## 4.8 Inventory Control

Once goods are purchased, they represent an *inventory* used during the construction process. The general objective of inventory control is to minimize the total cost of keeping the inventory while making tradeoffs among the major categories of costs: (1) purchase costs, (2) order cost, (3) holding costs, and (4) unavailable cost. These cost categories are interrelated since reducing cost in one category may increase cost in others. The costs in all categories generally are subject to considerable uncertainty.

### Purchase Costs

The *purchase cost* of an item is the unit purchase price from an external source including transportation and freight costs. For construction materials, it is common to receive discounts for bulk purchases, so the unit purchase cost declines as quantity increases. These reductions may reflect manufacturers' marketing policies, economies of scale in the material production, or scale economies in transportation. There are also advantages in having homogeneous materials. For example, a bulk order to insure the same color or size of items such as bricks may be desirable. Accordingly, it is usually desirable to make a limited number of large purchases for materials. In some cases, organizations may consolidate small orders from a number of different projects to capture such bulk discounts; this is a basic saving to be derived from a central purchasing office.

The cost of materials is based on prices obtained through effective bargaining. Unit prices of materials depend on bargaining leverage, quantities and delivery time. Organizations with potential for long-term purchase volume can command better bargaining leverage. While orders in large quantities may result in lower unit prices, they may also increase holding costs and thus cause problems in cash flow. Requirements of short delivery time can also adversely affect unit prices. Furthermore, design characteristics which include items of odd sizes or shapes should be avoided. Since such items normally are not available in the standard stockpile, purchasing them causes higher prices.

The transportation costs are affected by shipment sizes and other factors. Shipment by the full load of a carrier often reduces prices and assures quicker delivery, as the carrier can travel from the origin to the destination of the full load without having to stop for delivering part of the cargo at other stations. Avoiding transshipment is another consideration in reducing shipping cost. While the reduction in shipping costs is a major objective, the requirements of delicate handling of some items may favor a more expensive mode of transportation to avoid breakage and replacement costs.

### Order Cost

The *order* cost reflects the administrative expense of issuing a purchase order to an outside supplier. Order costs include expenses of making requisitions, analyzing alternative vendors, writing purchase orders, receiving materials, inspecting materials, checking on orders, and maintaining records of the entire process. Order costs are usually only a small portion of total costs for material management in construction projects, although ordering may require substantial time.

### Holding Costs

The *holding costs* or *carrying costs* are primarily the result of capital costs, handling, storage, obsolescence, shrinkage and deterioration. Capital cost results from the opportunity cost or financial expense of capital tied up in inventory. Once payment for goods is made, borrowing costs are incurred or capital must be diverted from other productive uses. Consequently, a capital carrying cost is incurred equal to the value of the inventory during a period multiplied by the interest rate obtainable or paid during that period. Note that capital costs only accumulate when payment for materials actually occurs; many organizations attempt to delay payments as long as possible to minimize such costs. Handling and storage represent the movement and protection charges incurred for materials. Storage costs also include the disruption caused to other project activities by large inventories of materials that get in the way. Obsolescence is the risk that an item will lose value because of changes in specifications. Shrinkage is the decrease in inventory over time due to theft or loss. Deterioration reflects a change in material quality due to age or environmental degradation. Many of these *holding cost* components are difficult to predict in advance; a project manager knows only that there is some chance that specific categories of cost will occur. In addition to these major categories of cost, there may be ancillary costs of additional insurance, taxes (many states treat inventories as taxable property), or additional fire hazards. As a general rule, holding costs will typically represent 20 to 40% of the average inventory value over the course of a year; thus if the average material inventory on a project is \$ 1 million over a year, the holding cost might be expected to be \$200,000 to \$400,000.

### Unavailability Cost

The *unavailability cost* is incurred when a desired material is not available at the desired time. In manufacturing industries, this cost is often called the *stockout* or *depletion* cost. Shortages may delay work, thereby wasting labor resources or delaying the completion of the entire project. Again, it may be difficult to forecast in advance exactly when an item may be required or when a shipment will be received. While the project schedule gives one estimate, deviations from the schedule may occur during construction. Moreover, the cost associated with a shortage may also be difficult to assess; if the material used for one activity is not available, it may be possible to assign workers to other activities and, depending upon which activities are critical, the project may not be delayed.

[Back to top](#)

## 4.9 Tradeoffs of Costs in Materials Management.

To illustrate the type of trade-offs encountered in materials management, suppose that a particular item is to be ordered for a project. The

amount of time required for processing the order and shipping the item is uncertain. Consequently, the project manager must decide how much lead time to provide in ordering the item. Ordering early and thereby providing a long lead time will increase the chance that the item is available when needed, but it increases the costs of inventory and the chance of spoilage on site.

Let  $T$  be the time for the delivery of a particular item,  $R$  be the time required for process the order, and  $S$  be the shipping time. Then, the minimum amount of time for the delivery of the item is  $T = R + S$ . In general, both  $R$  and  $S$  are random variables; hence  $T$  is also a random variable. For the sake of simplicity, we shall consider only the case of instant processing for an order, i.e.  $R = 0$ . Then, the delivery time  $T$  equals the shipping time  $S$ .

Since  $T$  is a random variable, the chance that an item will be delivered on day  $t$  is represented by the probability  $p(t)$ . Then, the probability that the item will be delivered on or before  $t$  day is given by:

$$4.1 \quad P_r\{T \leq t\} = \sum_{u=0}^t p(u)$$

If  $a$  and  $b$  are the lower and upper bounds of possible delivery dates, the expected delivery time is then given by:

$$4.2 \quad E[T] = \sum_{t=a}^b t[p(t)]$$

The lead time  $L$  for ordering an item is the time period ahead of the delivery time, and will depend on the tradeoff between holding costs and unavailability costs. A project manager may want to avoid the unavailable cost by requiring delivery on the scheduled date of use, or may be to lower the holding cost by adopting a more flexible lead time based on the expected delivery time. For example, the manager may make the tradeoff by specifying the lead time to be  $D$  days more than the expected delivery time, i.e.,

$$4.3 \quad L = E[T] + D$$

where  $D$  may vary from 0 to the number of additional days required to produce certain delivery on the desired date.

In a more realistic situation, the project manager would also contend with the uncertainty of exactly when the item might be required. Even if the item is *scheduled* for use on a particular date, the work progress might vary so that the desired date would differ. In many cases, greater than expected work progress may result in no savings because materials for future activities are unavailable.

#### Example 4-7: : Lead time for ordering with no processing time.

Table 4-1 summarizes the probability of different delivery times for an item. In this table, the first column lists the possible shipping times (ranging from 10 to 16 days), the second column lists the probability or chance that this shipping time will occur and the third column summarizes the chance that the item arrives on or before a particular date. This table can be used to indicate the chance that the item will arrive on a desired date for different lead times. For example, if the order is placed 12 days in advance of the desired date (so the lead time is 12 days), then there is a 15% chance that the item will arrive exactly on the desired day and a 35% chance that the item will arrive on or before the desired date. Note that this implies that there is a  $1 - 0.35 = 0.65$  or 65% chance that the item will not arrive by the desired date with a lead time of 12 days. Given the information in Table 4-1, when should the item order be placed?

**Table 4-1** Delivery Date on Orders and Probability of Delivery for an Example

Delivery Date $t$	Probability of delivery on date $t$ $p(t)$	Cummulative probability of delivery by day $t$ $\Pr\{T \leq t\}$
10	0.10	0.10
11	0.10	0.20
12	0.15	0.35
13	0.20	0.55
14	0.30	0.85
15	0.10	0.95
16	0.05	1.00

Suppose that the scheduled date of use for the item is in 16 days. To be completely certain to have delivery by the desired day, the order should be placed 16 days in advance. However, the expected delivery date with a 16 day lead time would be:

$$E[T] = \sum_{t=10}^{16} t[p(t)] =$$

$$= (10)(0.1) + (11)(0.1) + (12)(0.15) + (13)(0.20) + (14)(0.30) + (15)(0.10) + (16)(0.05) = 13.0$$

Thus, the actual delivery date may be  $16-13 = 3$  days early, and this early delivery might involve significant holding costs. A project manager might then decide to provide a lead time so that the *expected* delivery date was equal to the desired assembly date as long as the availability of the item was not critical. Alternatively, the project manager might negotiate a more certain delivery date from the supplier.

[Back to top](#)

## 4.10 Construction Equipment

The selection of the appropriate type and size of construction equipment often affects the required amount of time and effort and thus the job-site productivity of a project. It is therefore important for site managers and construction planners to be familiar with the characteristics of the major types of equipment most commonly used in construction. [\[9\]](#)

### Excavation and Loading

One family of construction machines used for excavation is broadly classified as a *crane-shovel* as indicated by the variety of machines in Figure 4-3. The crane-shovel consists of three major components:

- a carrier or mounting which provides mobility and stability for the machine.
- a revolving deck or turntable which contains the power and control units.
- a front end attachment which serves the special functions in an operation.

The type of mounting for all machines in Figure 4-3 is referred to as *crawler mounting*, which is particularly suitable for crawling over relatively rugged surfaces at a job site. Other types of mounting include *truck mounting* and *wheel mounting* which provide greater mobility between job sites, but require better surfaces for their operation. The revolving deck includes a cab to house the person operating the mounting and/or the revolving deck. The types of front end attachments in Figure 4-3 might include a crane with hook, clam shell, dragline, backhoe, shovel and piledriver.

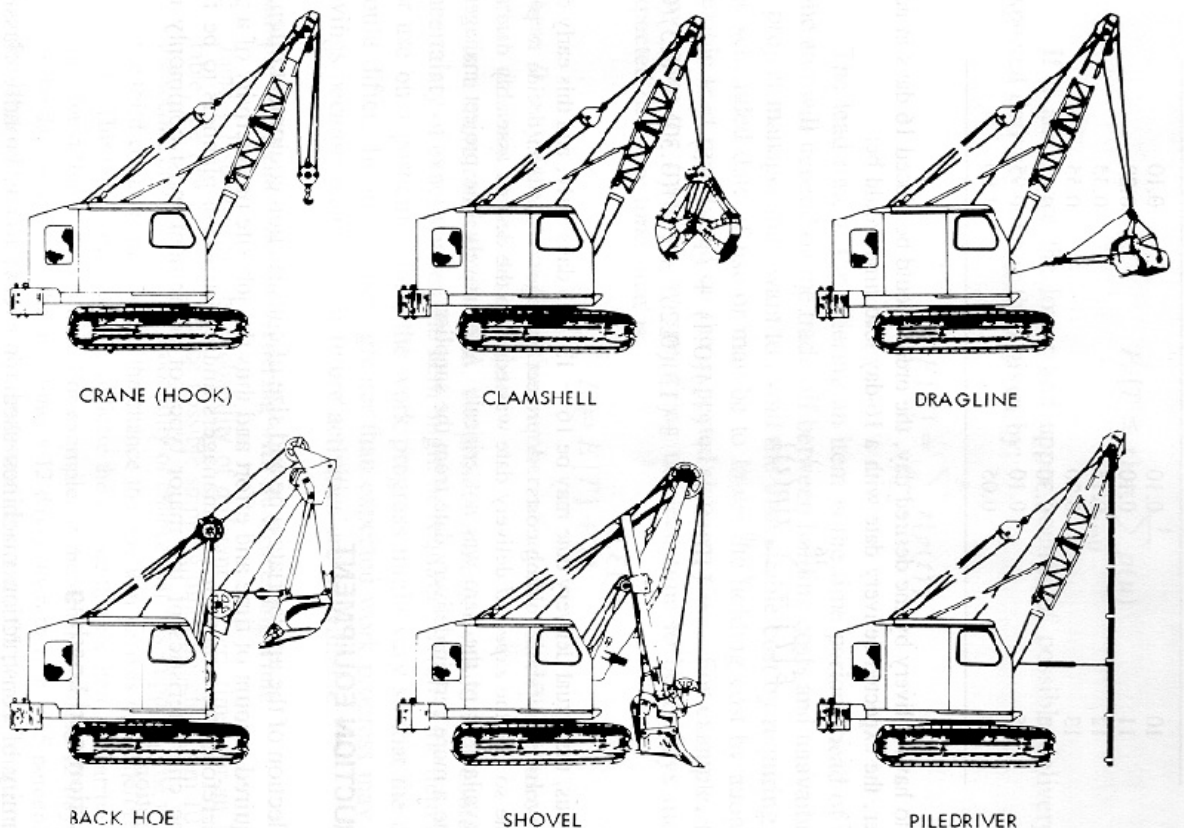

**Figure 4-3** Typical Machines in the Crane-Shovel Family

A tractor consists of a crawler mounting and a non-revolving cab. When an earth moving blade is attached to the front end of a tractor, the assembly is called a bulldozer. When a bucket is attached to its front end, the assembly is known as a loader or bucket loader. There are different types of loaders designed to handle most efficiently materials of different weights and moisture contents.

Scrapers are multiple-units of tractor-truck and blade-bucket assemblies with various combinations to facilitate the loading and hauling of earthwork. Major types of scrapers include single engine two-axle or three axle scrapers, twin-engine all-wheel-drive scrapers, elevating scrapers, and push-pull scrapers. Each type has different characteristics of rolling resistance, maneuverability stability, and speed in operation.

### **Compaction and Grading**

The function of compaction equipment is to produce higher density in soil mechanically. The basic forces used in compaction are static weight, kneading, impact and vibration. The degree of compaction that may be achieved depends on the properties of soil, its moisture content, the thickness of the soil layer for compaction and the method of compaction. Some major types of compaction equipment are shown in Figure 4-4, which includes rollers with different operating characteristics.

The function of grading equipment is to bring the earthwork to the desired shape and elevation. Major types of grading equipment include motor graders and grade trimmers. The former is an all-purpose machine for grading and surface finishing, while the latter is used for heavy construction because of its higher operating speed.



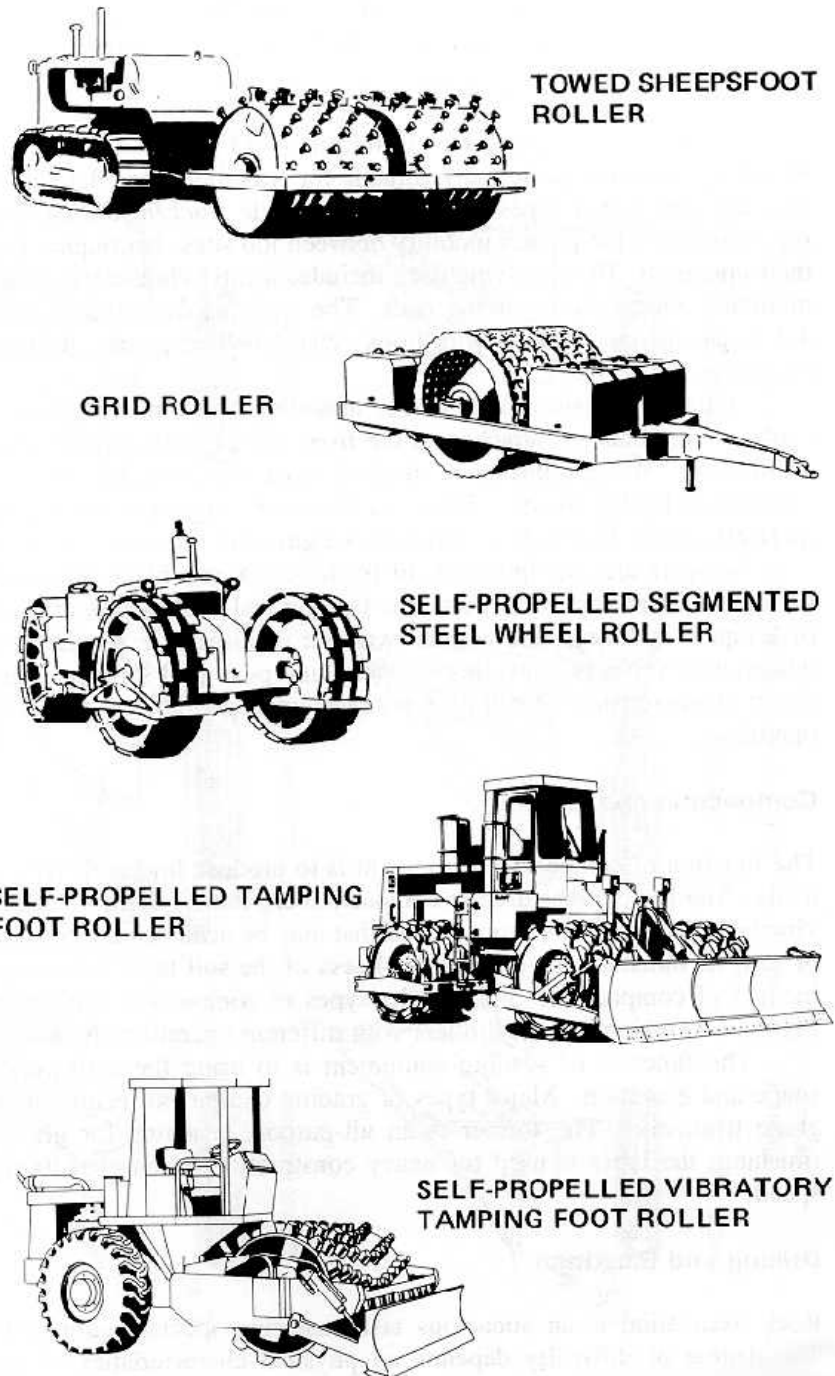

**Figure 4-4** Some Major Types of Compaction Equipment

### Drilling and Blasting

Rock excavation is an audacious task requiring special equipment and methods. The degree of difficulty depends on physical characteristics of the rock type to be excavated, such as grain size, planes of weakness, weathering, brittleness and hardness. The task of rock excavation includes loosening, loading, hauling and compacting. The loosening operation is specialized for rock excavation and is performed by drilling, blasting or ripping.

Major types of drilling equipment are percussion drills, rotary drills, and rotary-percussion drills. A percussion drill penetrates and cuts rock by impact while it rotates without cutting on the upstroke. Common types of percussion drills include a jackhammer which is hand-held and others which are mounted on a fixed frame or on a wagon or crawl for mobility. A rotary drill cuts by turning a bit against the rock surface. A

rotary-percussion drill combines the two cutting movements to provide a faster penetration in rock.

Blasting requires the use of explosives, the most common of which is dynamite. Generally, electric blasting caps are connected in a circuit with insulated wires. Power sources may be power lines or blasting machines designed for firing electric cap circuits. Also available are non-electrical blasting systems which combine the precise timing and flexibility of electric blasting and the safety of non-electrical detonation.

Tractor-mounted rippers are capable of penetrating and prying loose most rock types. The blade or ripper is connected to an adjustable shank which controls the angle at the tip of the blade as it is raised or lowered. Automated ripper control may be installed to control ripping depth and tip angle.

In rock tunneling, special tunnel machines equipped with multiple cutter heads and capable of excavating full diameter of the tunnel are now available. Their use has increasingly replaced the traditional methods of drilling and blasting.

### **Lifting and Erecting**

Derricks are commonly used to lift equipment or materials in industrial or building construction. A derrick consists of a vertical mast and an inclined boom sprouting from the foot of the mast. The mast is held in position by guys or stifflegs connected to a base while a topping lift links the top of the mast and the top of the inclined boom. A hook in the road line hanging from the top of the inclined boom is used to lift loads. Guy derricks may easily be moved from one floor to the next in a building under construction while stiffleg derricks may be mounted on tracks for movement within a work area.

Tower cranes are used to lift loads to great heights and to facilitate the erection of steel building frames. Horizon boom type tower cranes are most common in highrise building construction. Inclined boom type tower cranes are also used for erecting steel structures.

### **Mixing and Paving**

Basic types of equipment for paving include machines for dispensing concrete and bituminous materials for pavement surfaces. Concrete mixers may also be used to mix portland cement, sand, gravel and water in batches for other types of construction other than paving.

A truck mixer refers to a concrete mixer mounted on a truck which is capable of transporting ready mixed concrete from a central batch plant to construction sites. A paving mixer is a self propelled concrete mixer equipped with a boom and a bucket to place concrete at any desired point within a roadway. It can be used as a stationary mixer or used to supply slipform pavers that are capable of spreading, consolidating and finishing a concrete slab without the use of forms.

A bituminous distributor is a truck-mounted plant for generating liquid bituminous materials and applying them to road surfaces through a spray bar connected to the end of the truck. Bituminous materials include both asphalt and tar which have similar properties except that tar is not soluble in petroleum products. While asphalt is most frequently used for road surfacing, tar is used when the pavement is likely to be heavily exposed to petroleum spills.

### **Construction Tools and Other Equipment**

Air compressors and pumps are widely used as the power sources for construction tools and equipment. Common pneumatic construction tools include drills, hammers, grinders, saws, wrenches, staple guns, sandblasting guns, and concrete vibrators. Pumps are used to supply water or to dewater at construction sites and to provide water jets for some types of construction.

### **Automation of Equipment**

The introduction of new mechanized equipment in construction has had a profound effect on the cost and productivity of construction as well as the methods used for construction itself. An exciting example of innovation in this regard is the introduction of computer microprocessors on tools and equipment. As a result, the performance and activity of equipment can be continually monitored and adjusted for improvement. In many cases, automation of at least part of the construction process is possible and desirable. For example, wrenches that automatically monitor the elongation of bolts and the applied torque can be programmed to achieve the best bolt tightness. On grading projects, laser controlled scrapers can produce desired cuts faster and more precisely than wholly manual methods. [\[10\]](#) Possibilities for automation and robotics in construction are explored more fully in Chapter 16.

#### **Example 4-8: Tunneling Equipment [\[11\]](#)**

In the mid-1980's, some Japanese firms were successful in obtaining construction contracts for tunneling in the United States by using new equipment and methods. For example, the Japanese firm of Ohbayashi won the sewer contract in San Francisco because of its advanced tunneling technology. When a tunnel is dug through soft earth, as in San Francisco, it must be maintained at a few atmospheres of pressure to keep it from caving in. Workers must spend several hours in a pressure chamber before entering the tunnel and several more in decompression afterwards. They can stay inside for only three or four hours, always at considerable risk from cave-ins and asphyxiation. Ohbayashi used the new Japanese "earth-pressure-balance" method, which eliminates these problems. Whirling blades advance slowly, cutting the tunnel. The loose earth temporarily remains behind to balance the pressure of the compact earth on all sides. Meanwhile, prefabricated concrete segments are inserted and joined with waterproof seals to line the tunnel. Then the loose earth is conveyed away. This new tunneling method enabled Ohbayashi to bid \$5 million below the engineer's estimate for a San Francisco sewer. The firm completed the tunnel three months ahead of schedule. In effect, an innovation involving new technology and method led to considerable cost and time

savings.

[Back to top](#)

## 4.11 Choice of Equipment and Standard Production Rates

Typically, construction equipment is used to perform essentially repetitive operations, and can be broadly classified according to two basic functions: (1) operators such as cranes, graders, etc. which stay within the confines of the construction site, and (2) haulers such as dump trucks, ready mixed concrete truck, etc. which transport materials to and from the site. In both cases, the cycle of a piece of equipment is a sequence of tasks which is repeated to produce a unit of output. For example, the sequence of tasks for a crane might be to fit and install a wall panel (or a package of eight wall panels) on the side of a building; similarly, the sequence of tasks of a ready mixed concrete truck might be to load, haul and unload two cubic yards (or one truck load) of fresh concrete.

In order to increase job-site productivity, it is beneficial to select equipment with proper characteristics and a size most suitable for the work conditions at a construction site. In excavation for building construction, for examples, factors that could affect the selection of excavators include:

1. **Size of the job:** Larger volumes of excavation will require larger excavators, or smaller excavators in greater number.
2. **Activity time constraints:** Shortage of time for excavation may force contractors to increase the size or numbers of equipment for activities related to excavation.
3. **Availability of equipment:** Productivity of excavation activities will diminish if the equipment used to perform them is available but not the most adequate.
4. **Cost of transportation of equipment:** This cost depends on the size of the job, the distance of transportation, and the means of transportation.
5. **Type of excavation:** Principal types of excavation in building projects are cut and/or fill, excavation massive, and excavation for the elements of foundation. The most adequate equipment to perform one of these activities is not the most adequate to perform the others.
6. **Soil characteristics:** The type and condition of the soil is important when choosing the most adequate equipment since each piece of equipment has different outputs for different soils. Moreover, one excavation pit could have different soils at different stratum.
7. **Geometric characteristics of elements to be excavated:** Functional characteristics of different types of equipment makes such considerations necessary.
8. **Space constraints:** The performance of equipment is influenced by the spatial limitations for the movement of excavators.
9. **Characteristics of haul units:** The size of an excavator will depend on the haul units if there is a constraint on the size and/or number of these units.
10. **Location of dumping areas:** The distance between the construction site and dumping areas could be relevant not only for selecting the type and number of haulers, but also the type of excavators.
11. **Weather and temperature:** Rain, snow and severe temperature conditions affect the job-site productivity of labor and equipment.

By comparing various types of machines for excavation, for example, power shovels are generally found to be the most suitable for excavating from a level surface and for attacking an existing digging surface or one created by the power shovel; furthermore, they have the capability of placing the excavated material directly onto the haulers. Another alternative is to use bulldozers for excavation.

The choice of the type and size of haulers is based on the consideration that the number of haulers selected must be capable of disposing of the excavated materials expeditiously. Factors which affect this selection include:

1. **Output of excavators:** The size and characteristics of the excavators selected will determine the output volume excavated per day.
2. **Distance to dump site:** Sometimes part of the excavated materials may be piled up in a corner at the job-site for use as backfill.
3. **Probable average speed:** The average speed of the haulers to and from the dumping site will determine the cycle time for each hauling trip.
4. **Volume of excavated materials:** The volume of excavated materials including the part to be piled up should be hauled away as soon as possible.
5. **Spatial and weight constraints:** The size and weight of the haulers must be feasible at the job site and over the route from the construction site to the dumping area.

Dump trucks are usually used as haulers for excavated materials as they can move freely with relatively high speeds on city streets as well as on highways.

The cycle capacity  $C$  of a piece of equipment is defined as the number of output units per cycle of operation under standard work conditions. The capacity is a function of the output units used in the measurement as well as the size of the equipment and the material to be processed. The cycle time  $T$  refers to units of time per cycle of operation. The standard production rate  $R$  of a piece of construction equipment is defined as the number of output units per unit time. Hence:

$$4.4 \quad R = \frac{C}{T}$$

or

$$4.5 \quad T = \frac{C}{R}$$

The daily standard production rate  $P_e$  of an excavator can be obtained by multiplying its standard production rate  $R_e$  by the number of operating hours  $H_e$  per day. Thus:

$$4.6 \quad P_e = R_e H_e = \frac{C_e H_e}{T_e}$$

where  $C_e$  and  $T_e$  are cycle capacity (in units of volume) and cycle time (in hours) of the excavator respectively.

In determining the daily standard production rate of a hauler, it is necessary to determine first the cycle time from the distance  $D$  to a dump site and the average speed  $S$  of the hauler. Let  $T_t$  be the travel time for the round trip to the dump site,  $T_o$  be the loading time and  $T_d$  be the dumping time. Then the travel time for the round trip is given by:

$$4.7 \quad T_t = \frac{2D}{S}$$

The loading time is related to the cycle time of the excavator  $T_e$  and the relative capacities  $C_h$  and  $C_e$  of the hauler and the excavator respectively. In the optimum or standard case:

$$4.8 \quad T_o = T_e \frac{C_h}{C_e}$$

For a given dumping time  $T_d$ , the cycle time  $T_h$  of the hauler is given by:

$$4.9 \quad T_h = \frac{2D}{S} + T_e \frac{C_h}{C_e} + T_d$$

The daily standard production rate  $P_h$  of a hauler can be obtained by multiplying its standard production rate  $R_h$  by the number of operating hours  $H_h$  per day. Hence:

$$4.10 \quad P_h = R_h H_h = \frac{C_h H_h}{T_h}$$

This expression assumes that haulers begin loading as soon as they return from the dump site.

The number of haulers required is also of interest. Let  $w$  denote the swell factor of the soil such that  $wP_e$  denotes the daily volume of loose excavated materials resulting from the excavation volume  $P_e$ . Then the approximate number of haulers required to dispose of the excavated materials is given by:

$$4.11 \quad N_h = \frac{wP_e}{P_h}$$

While the standard production rate of a piece of equipment is based on "standard" or ideal conditions, equipment productivities at job sites are influenced by actual work conditions and a variety of inefficiencies and work stoppages. As one example, various factor adjustments can be used to account in an approximate fashion for actual site conditions. If the conditions that lower the standard production rate are denoted by  $n$  factors  $F_1, F_2, \dots, F_n$ , each of which is smaller than 1, then the actual equipment productivity  $R'$  at the job site can be related to the standard production rate  $R$  as follows:

$$4.12 \quad R' \approx R F_1 F_2 \dots F_n$$

On the other hand, the cycle time  $T'$  at the job site will be increased by these factors, reflecting actual work conditions. If only these factors are involved,  $T'$  is related to the standard cycle time  $T$  as:

$$4.13 \quad T' \approx \frac{T}{F_1 F_2 \dots F_n}$$

Each of these various adjustment factors must be determined from experience or observation of job sites. For example, a bulk composition factor is derived for bulk excavation in building construction because the standard production rate for general bulk excavation is reduced when an excavator is used to create a ramp to reach the bottom of the bulk and to open up a space in the bulk to accommodate the hauler.

In addition to the problem of estimating the various factors,  $F_1, F_2, \dots, F_n$ , it may also be important to account for interactions among the factors and the exact influence of particular site characteristics.

**Example 4-9: Daily standard production rate of a power shovel [12]**

A power shovel with a dipper of one cubic yard capacity has a standard operating cycle time of 30 seconds. Find the daily standard production rate of the shovel.

For  $C_e = 1$  cu. yd.,  $T_e = 30$  sec. and  $H_e = 8$  hours, the daily standard production rate is found from Eq. (4.6) as follows:

$$P_e = \frac{(1 \text{ yd}^3)(8 \text{ hr})(3,600 \text{ sec/hr})}{30 \text{ sec}} = 960 \text{ yd}^3$$

In practice, of course, this standard rate would be modified to reflect various production inefficiencies, as described in Example 4-11.

**Example 4-10: Daily standard production rate of a dump truck**

A dump truck with a capacity of 6 cubic yards is used to dispose of excavated materials at a dump site 4 miles away. The average speed of the dump truck is 30 mph and the dumping time is 30 seconds. Find the daily standard production rate of the truck. If a fleet of dump trucks of this capacity is used to dispose of the excavated materials in Example 4-9 for 8 hours per day, determine the number of trucks needed daily, assuming a swell factor of 1.1 for the soil.

The daily standard production rate of a dump truck can be obtained by using Equations (4.7) through (4.10):

$$T_i = \frac{(2)(4 \text{ mi})(3,600 \text{ sec/hr})}{(30 \text{ mi/hr})} = 960 \text{ sec}$$

$$T_o = (30 \text{ sec}) \left( \frac{6 \text{ yd}^3}{1 \text{ yd}^3} \right) = 180 \text{ sec}$$

$$T_h = 960 + 180 + 30 = 1,170 \text{ sec}$$

Hence, the daily hauler productivity is:

$$P_h = \frac{(6 \text{ yd}^3)(8 \text{ hr})(3,600 \text{ sec/hr})}{(1,170 \text{ sec})} = 147.7 \text{ yd}^3$$

Finally, from Equation (4.12), the number of trucks required is:

$$N_h = \frac{(1.1)(960 \text{ yd}^3)}{147.7 \text{ yd}^3} = 7.1$$

implying that 8 trucks should be used.

**Example 4-11: Job site productivity of a power shovel**

A power shovel with a dipper of one cubic yard capacity (in Example 4-9) has a standard production rate of 960 cubic yards for an 8-hour day. Determine the job site productivity and the actual cycle time of this shovel under the work conditions at the site that affects its productivity as shown below:

Work Conditions at the Site	Factors
Bulk composition	0.954

Soil properties and water content	0.983
Equipment idle time for worker breaks	0.8
Management efficiency	0.7

Using Equation (4.11), the job site productivity of the power shovel per day is given by:

$$P'_e = (960 \text{ yd}^3)(0.954)(0.983)(0.8)(0.7) = 504 \text{ yd}^3$$

The actual cycle time can be determined as follows:

$$T'_e = \frac{(30 \text{ sec})}{(0.954)(0.983)(0.8)(0.7)} = 57 \text{ sec}$$

Noting Equation (4.6), the actual cycle time can also be obtained from the relation  $T'_e = (C_e H_e) / P'_e$ . Thus:

$$T'_e = \frac{(1 \text{ yd}^3)(8 \text{ hr})(3,600 \text{ sec/hr})}{504 \text{ yd}^3} = 57 \text{ sec}$$

#### Example 4-12: Job site productivity of a dump truck

A dump truck with a capacity of 6 cubic yards (in Example 4-10) is used to dispose of excavated materials. The distance from the dump site is 4 miles and the average speed of the dump truck is 30 mph. The job site productivity of the power shovel per day (in Example 4-11) is 504 cubic yards, which will be modified by a swell factor of 1.1. The only factors affecting the job site productivity of the dump truck in addition to those affecting the power shovel are 0.80 for equipment idle time and 0.70 for management efficiency. Determine the job site productivity of the dump truck. If a fleet of such trucks is used to haul the excavated material, find the number of trucks needed daily.

The actual cycle time  $T'_h$  of the dump truck can be obtained by summing the actual times for traveling, loading and dumping:

$$T'_t = \frac{T_t}{F_1 F_2} = \frac{(2)(4 \text{ mi})(3,600 \text{ sec/hr})}{(30 \text{ mi/hr})(0.8)(0.7)} = 1,714 \text{ sec}$$

$$T'_o = \frac{T'_e C_h}{F_1 F_2 C_e} = \left( \frac{57 \text{ sec}}{(0.8)(0.7)} \right) \left( \frac{6 \text{ yd}^3}{1 \text{ yd}^3} \right) = 611 \text{ sec}$$

$$T'_d = \frac{T_d}{F_1 F_2} = \frac{30 \text{ sec}}{(0.8)(0.7)} = 54 \text{ sec}$$

Hence, the actual cycle time is:

$$T'_h = T'_t + T'_o + T'_d = 1,714 + 611 + 54 = 2,379 \text{ sec}$$

The jobsite productivity  $P'_h$  of the dump truck per day is:

$$P'_h = \frac{C_h H_h}{T'_h} = \frac{(6 \text{ yd}^3)(8 \text{ hr})(3,600 \text{ sec/hr})}{2,379 \text{ sec}} = 72.6 \text{ yd}^3$$

The number of trucks needed daily is:

$$N'_h = \frac{w P'_e}{P'_h} = \frac{(1.1)(504 \text{ yd}^3)}{72.6 \text{ yd}^3} = 7.6$$

so 8 trucks are required.

[Back to top](#)

## 4.12 Construction Processes

The previous sections described the primary inputs of labor, material and equipment to the construction process. At varying levels of detail, a project manager must insure that these inputs are effectively coordinated to achieve an efficient construction process. This coordination involves both strategic decisions and tactical management in the field. For example, strategic decisions about appropriate technologies or site layout are often made during the process of construction planning. During the course of construction, foremen and site managers will make decisions about work to be undertaken at particular times of the day based upon the availability of the necessary resources of labor, materials and equipment. Without coordination among these necessary inputs, the construction process will be inefficient or stop altogether.

### Example 4-13: Steel erection

Erection of structural steel for buildings, bridges or other facilities is an example of a construction process requiring considerable coordination. Fabricated steel pieces must arrive on site in the correct order and quantity for the planned effort during a day. Crews of steelworkers must be available to fit pieces together, bolt joints, and perform any necessary welding. Cranes and crane operators may be required to lift fabricated components into place; other activities on a job site may also be competing for use of particular cranes. Welding equipment, wrenches and other hand tools must be readily available. Finally, ancillary materials such as bolts of the correct size must be provided.

In coordinating a process such as steel erection, it is common to assign different tasks to specific crews. For example, one crew may place members in place and insert a few bolts in joints in a specific area. A following crew would be assigned to finish bolting, and a third crew might perform necessary welds or attachment of brackets for items such as curtain walls.

With the required coordination among these resources, it is easy to see how poor management or other problems can result in considerable inefficiency. For example, if a shipment of fabricated steel is improperly prepared, the crews and equipment on site may have to wait for new deliveries.

### Example 4-14: Construction process simulation models

Computer based simulation of construction operations can be a useful although laborious tool in analyzing the efficiency of particular processes or technologies. These tools tend to be either oriented toward modeling resource processes or towards representation of spatial constraints and resource movements. Later chapters will describe simulation in more detail, but a small example of a construction operation model can be described here. [13] The process involved placing concrete within existing formwork for the columns of a new structure. A crane-and-bucket combination with one cubic yard capacity and a flexible "elephant trunk" was assumed for placement. Concrete was delivered in trucks with a capacity of eight cubic yards. Because of site constraints, only one truck could be moved into the delivery position at a time. Construction workers and electric immersion-type concrete vibrators were also assumed for the process.

The simulation model of this process is illustrated in Figure 4-5. Node 2 signals the availability of a concrete truck arriving from the batch plant. As with other circular nodes in Figure 4-5, the availability of a truck may result in a resource waiting or *queueing* for use. If a truck (node 2) and the crane (node 3) are both available, then the crane can load and hoist a bucket of concrete (node 4). As with other rectangular nodes in the model, this operation will require an appreciable period of time. On the completion of the load and hoist operations, the bucket (node 5) is available for concrete placement. Placement is accomplished by having a worker guide the bucket's elephant trunk between the concrete forms and having a second worker operate the bucket release lever. A third laborer operates a vibrator in the concrete while the bucket (node 8) moves back to receive a new load. Once the concrete placement is complete, the crew becomes available to place a new bucket load (node 7). After two buckets are placed, then the column is complete (node 9) and the equipment and crew can move to the next column (node 10). After the movement to the new column is complete, placement in the new column can begin (node 11). Finally, after a truck is emptied (nodes 12 and 13), the truck departs and a new truck can enter the delivery stall (node 14) if one is waiting.

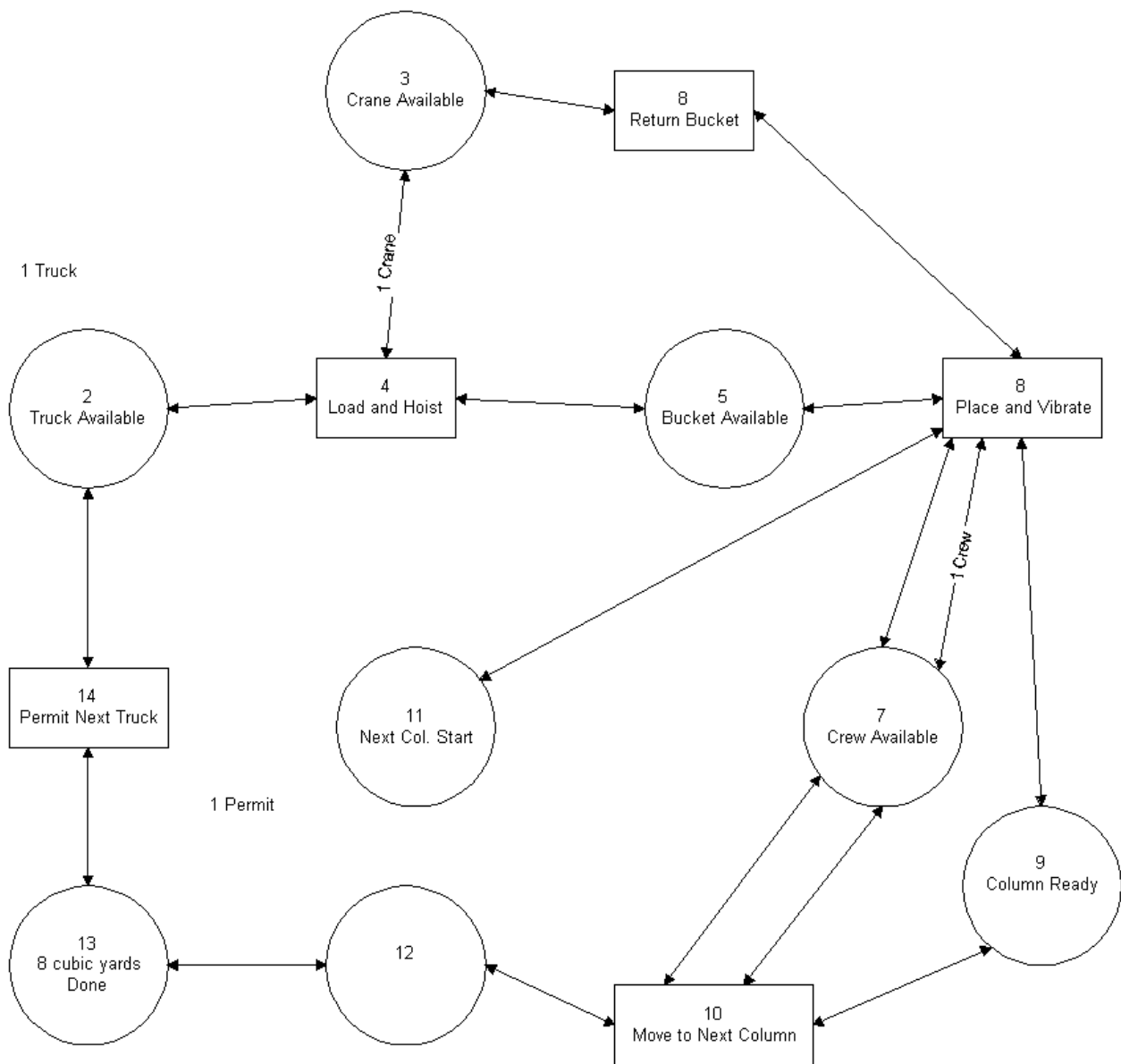

**Figure 4-5:** Illustration of a Concrete-Placing Simulation Model

Application of the simulation model consists of tracing through the time required for these various operations. Events are also simulated such as the arrival times of concrete trucks. If random elements are introduced, numerous simulations are required to estimate the actual productivity and resource requirements of the process. For example, one simulation of this process using four concrete trucks found that a truck was waiting 83% of the time with an average wait at the site of 14 minutes. This type of simulation can be used to estimate the various productivity adjustment factors described in the previous section.

[Back to top](#)

### 4.13 Queues and Resource Bottlenecks

A project manager needs to insure that resources required for and/or shared by numerous activities are adequate. Problems in this area can be indicated in part by the existence of queues of resource demands during construction operations. A *queue* can be a *waiting line* for service. One can imagine a queue as an orderly line of customers waiting for a stationary server such as a ticket seller. However, the demands for service might not be so neatly arranged. For example, we can speak of the *queue* of welds on a building site waiting for inspection. In this case, demands do not come to the server, but a roving inspector travels among the waiting service points. Waiting for resources such as a particular piece of equipment or a particular individual is an endemic problem on construction sites. If workers spend appreciable portions of time waiting for particular tools, materials or an inspector, costs increase and productivity declines. Insuring adequate resources to serve expected demands is an important problem during construction planning and field management.

In general, there is a trade-off between waiting times and utilization of resources. Utilization is the proportion of time a particular resource is



in productive use. Higher amounts of resource utilization will be beneficial as long as it does not impose undue costs on the entire operation. For example, a welding inspector might have one hundred percent utilization, but workers throughout the jobsite might be wasting inordinate time waiting for inspections. Providing additional inspectors may be cost effective, even if they are not utilized at all times.

A few conceptual models of queueing systems may be helpful to construction planners in considering the level of adequate resources to provide. First, we shall consider the case of time-varying demands and a server with a constant service rate. This might be the situation for an elevator in which large demands for transportation occur during the morning or at a shift change. Second, we shall consider the situation of randomly arriving demands for service and constant service rates. Finally, we shall consider briefly the problems involving multiple serving stations.

### Single-Server with Deterministic Arrivals and Services

Suppose that the cumulative number of demands for service or "customers" at any time  $t$  is known and equal to the value of the function  $A(t)$ . These "customers" might be crane loads, weld inspections, or any other defined group of items to be serviced. Suppose further that a single server is available to handle these demands, such as a single crane or a single inspector. For this model of queueing, we assume that the server can handle customers at some constant, maximum rate denoted as  $x$  "customers" per unit of time. This is a maximum rate since the server may be idle for periods of time if no customers are waiting. This system is *deterministic* in the sense that both the arrival function and the service process are assumed to have no random or unknown component.

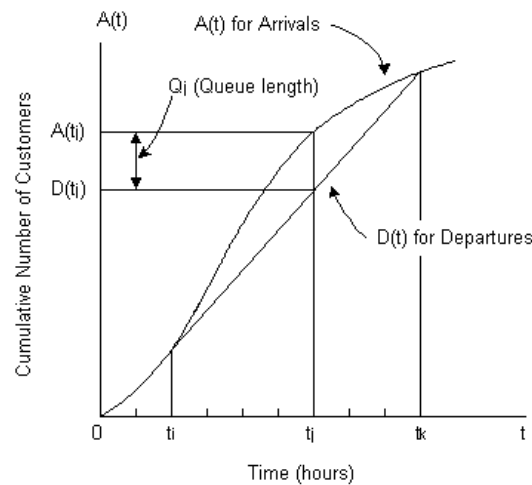

**Figure 4-6:** Cumulative Arrivals and Departures in a Deterministic Queue

A cumulative arrival function of customers,  $A(t)$ , is shown in Figure 4-6 in which the vertical axis represents the cumulative number of customers, while the horizontal axis represents the passage of time. The arrival of individual customers to the queue would actually represent a unit step in the arrival function  $A(t)$ , but these small steps are approximated by a continuous curve in the figure. The rate of arrivals for a unit time interval  $\Delta t$  from  $t-1$  to  $t$  is given by:

$$4.14 \quad \Delta A_t = A(t) - A(t-1)$$

While an hour or a minute is a natural choice as a unit time interval, other time periods may also be used as long as the passage of time is expressed as multiples of such time periods. For instance, if half an hour is used as unit time interval for a process involving ten hours, then the arrivals should be represented by 20 steps of half hour each. Hence, the unit time interval between  $t-1$  and  $t$  is  $\Delta t = t - (t-1) = 1$ , and the slope of the cumulative arrival function in the interval is given by:

$$4.15 \quad A'(t) = \frac{A(t) - A(t-1)}{\Delta t} = A(t) - A(t-1)$$

The cumulative number of customers served over time is represented by the cumulative departure function  $D(t)$ . While the maximum service rate is  $x$  per unit time, the actual service rate for a unit time interval  $\Delta t$  from  $t-1$  to  $t$  is:

$$4.16 \quad \Delta D_t = D(t) - D(t-1)$$

The slope of the cumulative departure function is:

$$4.17 \quad D'(t) = \frac{D(t) - D(t-1)}{\Delta t} = D(t) - D(t-1)$$

Any time that the rate of arrivals to the queue exceeds the maximum service rate, then a queue begins to form and the cumulative departures will occur at the maximum service rate. The cumulative departures from the queue will proceed at the maximum service rate of  $x$  "customers" per unit of time, so that the slope of  $D(t)$  is  $x$  during this period. The cumulative departure function  $D(t)$  can be readily constructed graphically by running a ruler with a slope of  $x$  along the cumulative arrival function  $A(t)$ . As soon as the function  $A(t)$  climbs above the ruler, a queue begins to form. The maximum service rate will continue until the queue disappears, which is represented by the convergence of the cumulative arrival and departure functions  $A(t)$  and  $D(t)$ .

With the cumulative arrivals and cumulative departure functions represented graphically, a variety of service indicators can be readily obtained as shown in Figure 4-6. Let  $A'(t)$  and  $D'(t)$  denote the derivatives of  $A(t)$  and  $D(t)$  with respect to  $t$ , respectively. For  $0 \leq t \leq t_1$  in which  $A'(t) \leq x$ , there is no queue. At  $t = t_1$ , when  $A'(t) > D'(t)$ , a queue is formed. Then  $D'(t) = x$  in the interval  $t_1 \leq t \leq t_k$ . As  $A'(t)$  continues to increase with increasing  $t$ , the queue becomes longer since the service rate  $D'(t) = x$  cannot catch up with the arrivals. However, when again  $A'(t) \leq D'(t)$  as  $t$  increases, the queue becomes shorter until it reaches 0 at  $t = t_k$ . At any given time  $t$ , the queue length is

$$4.18 \quad Q(t) = A(t) - D(t)$$

For example, suppose a queue begins to form at time  $t_1$  and is dispersed by time  $t_k$ . The maximum number of customers waiting or queue length is represented by the maximum difference between the cumulative arrival and cumulative departure functions between  $t_1$  and  $t_k$ , i.e. the maximum value of  $Q(t)$ . The total waiting time for service is indicated by the total area between the cumulative arrival and cumulative departure functions.

Generally, the arrival rates  $\Delta A_t = 1, 2, \dots, n$  periods of a process as well as the maximum service rate  $x$  are known. Then the cumulative arrival function and the cumulative departure function can be constructed systematically together with other pertinent quantities as follows:

1. Starting with the initial conditions  $D(t-1)=0$  and  $Q(t-1)=0$  at  $t=1$ , find the actual service rate at  $t=1$ :

$$4.19 \quad \Delta D_1 = \text{minimum} \{x, A_1\}$$

2. Starting with  $A(t-1)=0$  at  $t=1$ , find the cumulative arrival function for  $t=2,3, \dots, n$  accordingly:

$$4.20 \quad A(t) = A(t-1) + \Delta A_t$$

3. Compute the queue length for  $t=1,2, \dots, n$ .

$$4.21 \quad Q(t) = Q(t-1) + \Delta A_t - \Delta D_t$$

4. Compute  $\Delta D_t$  for  $t=2,3, \dots, n$  after  $Q(t-1)$  is found first for each  $t$ :

$$4.22 \quad \Delta D_t = \text{minimum} \{x, Q(t-1) + \Delta A_t\}$$

5. If  $A'(t) > x$ , find the cumulative departure function in the time period between  $t_1$  where a queue is formed and  $t_k$  where the queue dissipates:

$$4.23 \quad D(t) = D(t-1) + \Delta D_t$$

6. Compute the waiting time  $\Delta w$  for the arrivals which are waiting for service in interval  $\Delta t$ :

$$4.24 \quad \Delta w = Q(t)(\Delta t)$$

7. Compute the total waiting time  $W$  over the time period between  $t_1$  and  $t_k$ .

$$4.25 \quad W = \sum_{t=t_1}^{t_k} \Delta w$$

8. Compute the average waiting time  $w$  for arrivals which are waiting for service in the process.

$$4.26 \quad w = \frac{W}{A(t_k) - A(t_j)}$$

This simple, deterministic model has a number of implications for operations planning. First, an increase in the maximum service rate will result in reductions in waiting time and the maximum queue length. Such increases might be obtained by speeding up the service rate such as introducing shorter inspection procedures or installing faster cranes on a site. Second, altering the pattern of cumulative arrivals can result in changes in total waiting time and in the maximum queue length. In particular, if the maximum arrival rate never exceeds the maximum service rate, no queue will form, or if the arrival rate always exceeds the maximum service rate, the bottleneck cannot be dispersed. Both cases are shown in Figure 4-7.

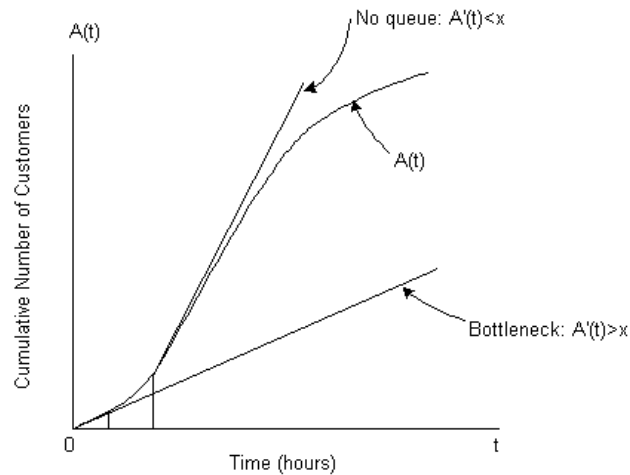

**Figure 4-7:** Cases of No Queue and Permanent Bottleneck

A practical means to alter the arrival function and obtain these benefits is to inaugurate a reservation system for customers. Even without drawing a graph such as Figure 4-6, good operations planners should consider the effects of different operation or service rates on the flow of work. Clearly, service rates less than the expected arrival rate of work will result in resource bottlenecks on a job.

### Single-Server with Random Arrivals and Constant Service Rate

Suppose that arrivals of "customers" to a queue are not deterministic or known as in Figure 4-6. In particular, suppose that "customers" such as joints are completed or crane loads arrive at random intervals. What are the implications for the smooth flow of work? Unfortunately, bottlenecks and queues may arise in this situation even if the maximum service rate is larger than the average or expected arrival rate of customers. This occurs because random arrivals will often bunch together, thereby temporarily exceeding the capacity of the system. While the average arrival rate may not change over time, temporary resource shortages can occur in this circumstance.

Let  $w$  be the average waiting time,  $a$  be the average arrival rate of customers, and  $x$  be the deterministic constant service rate (in customers per unit of time). Then, the expected average time for a customer in this situation is given by: [\[14\]](#)

$$4.27 \quad w = \frac{a}{2x^2 \left(1 - \frac{a}{x}\right)}$$

If the average utilization rate of the service is defined as the ratio of the average arrival rate and the constant service rate, i.e.,

$$4.28 \quad u = \frac{a}{x}$$

Then, Eq. (4.27) becomes:

$$4.29 \quad w = \frac{u}{2x(1-u)}$$

In this equation, the ratio  $u$  of arrival rate to service rate is very important: if the average arrival rate approaches the service rate, the waiting time can be very long. If  $a \geq \mu$ , then the queue expands indefinitely. Resource bottlenecks will occur with random arrivals unless a measure of extra service capacity is available to accommodate sudden bunches in the arrival stream. Figure 4-8 illustrates the waiting time resulting from different combinations of arrival rates and service times.

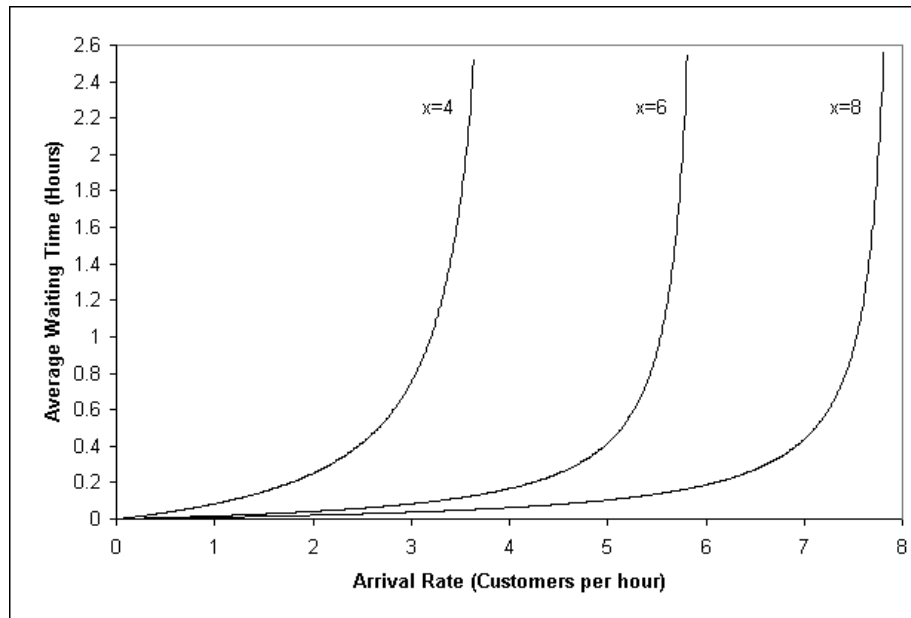

**Figure 4-8:** Illustrative Waiting Times for Different Average Arrival Rates and Service Times

### Multiple Servers

Both of the simple models of service performance described above are limited to single servers. In operations planning, it is commonly the case that numerous operators are available and numerous stages of operations exist. In these circumstances, a planner typically attempts to match the service rates occurring at different stages in the process. For example, construction of a high rise building involves a series of operations on each floor, including erection of structural elements, pouring or assembling a floor, construction of walls, installation of HVAC (Heating, ventilating and air conditioning) equipment, installation of plumbing and electric wiring, etc. A smooth construction process would have each of these various activities occurring at different floors at the same time without large time gaps between activities on any particular floor. Thus, floors would be installed soon after erection of structural elements, walls would follow subsequently, and so on. From the standpoint of a queueing system, the planning problem is to insure that the productivity or service rate per floor of these different activities are approximately equal, so that one crew is not continually waiting on the completion of a preceding activity or interfering with a following activity. In the realm of manufacturing systems, creating this balance among operations is called *assembly line balancing*.

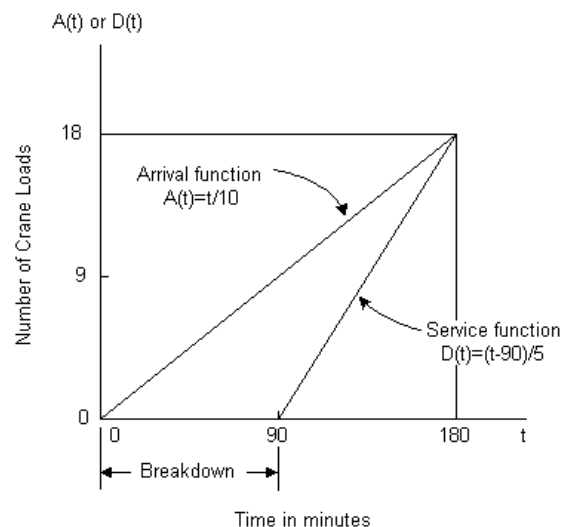

**Figure 4-9:** Arrivals and Services of Crane Loads with a Crane Breakdown

**Example 4-15: Effect of a crane breakdown**

Suppose that loads for a crane are arriving at a steady rate of one every ten minutes. The crane has the capacity to handle one load every five minutes. Suppose further that the crane breaks down for ninety minutes. How many loads are delayed, what is the total delay, and how long will be required before the crane can catch up with the backlog of loads?

The cumulative arrival and service functions are graphed in Figure 4-9. Starting with the breakdown at time zero, nine loads arrive during the ninety minute repair time. From Figure 4-9, an additional nine loads arrive before the entire queue is served. Algebraically, the required time for service,  $t$ , can be calculated by noting that the number of arrivals must equal the number of loads served. Thus:

$$A(t) = \frac{t}{10} \text{ for } t \geq 0$$

$$D_1(t) = 0 \text{ for } 0 \leq t \leq 90 \text{ min}$$

$$D_2(t) = \frac{t-90}{5} \text{ for } t \geq 90 \text{ min}$$

A queue is formed at  $t = 0$  because of the breakdown, but it dissipates at  $A(t) = D_2(t)$ . Let

$$\frac{t}{10} = \frac{t-90}{5}$$

from which we obtain  $t = 180$  min. Hence

$$A(180) = D_2(180) = 18 \text{ loads}$$

The total waiting time  $W$  can be calculated as the area between the cumulative arrival and service functions in Figure 4-9. Algebraically, this is conveniently calculated as the difference in the areas of two triangles:

$$W = \frac{(18)(180)}{2} - \frac{(18)(90)}{2} = 810 \text{ min}$$

so the average delay per load is  $w = 810/18 = 45$  minutes.

**Example 4-16: Waiting time with random arrivals**

Suppose that material loads to be inspected arrive randomly but with an average of 5 arrivals per hour. Each load requires ten minutes for an inspection, so an inspector can handle six loads per hour. Inspections must be completed before the material can be unloaded from a truck. The cost per hour of holding a material load in waiting is \$30, representing the cost of a driver and a truck. In this example, the arrival rate,  $a$ , equals 5 arrivals per hour and the service rate,  $x$ , equals 6 material loads per hour. Then, the average waiting time of any material load for  $u = 5/6$  is:

$$\frac{5/6}{(2)(6) - (1 - 5/6)} = 0.4 \text{ hr}$$

At a resource cost of \$30.00 per hour, this waiting would represent a cost of  $(30)(0.4)(5) = \$60.00$  per hour on the project.

In contrast, if the possible service rate is  $x = 10$  material loads per hour, then the expected waiting time of any material load for  $u = 5/10 = 0.5$  is:

$$\frac{0.5}{(2)(10)(1 - 0.5)} = 0.05 \text{ hr}$$

which has only a cost of  $(30)(0.05)(5) = \$7.50$  per hour.

**Example 4-17: Delay of lift loads on a building site**

Suppose that a single crane is available on a building site and that each lift requires three minutes including the time for attaching loads. Suppose further that the cumulative arrivals of lift loads at different time periods are as follows:

6:00-7:00 A.M.	4 per hour	12:00-4:00 P.M.	8 per hour
7:00-8:00 A.M.	15 per hour	4:00-6:00 P.M.	4 per hour
8:00-11:00 A.M.	25 per hour	6:00P.M.-6:00 A.M.	0 per hour
11:00-12:00 A.M.	5 per hour		

Using the above information of arrival and service rates

1. Find the cumulative arrivals and cumulative number of loads served as a function of time, beginning with 6:00 AM.
2. Estimate the maximum queue length of loads waiting for service. What time does the maximum queue occur?
3. Estimate the total waiting time for loads.
4. Graph the cumulative arrival and departure functions.

The maximum service rate  $x = 60 \text{ min}/3 \text{ min per lift} = 20 \text{ lifts per minute}$ . The detailed computation can be carried out in the Table 4-2, and the graph of  $A(t)$  and  $D(t)$  is given in Figure 4-10.

**Table 4-2 Computation of queue length and waiting time**

Period	Arrival rate	Cumulative arrivals $A(T)$	Queue	Departure rate	Cumulative departures $D(T)$	Waiting time
6-7:00	4	4	0	4	4	0
7-8:00	15	19	0	15	19	0
8-9:00	25	44	5	20	39	5
9-10:00	25	69	10	20	59	10
10-11:00	25	94	15	20	79	15
11-12:00	5	99	0	20	99	0
12-1:00	8	107	0	8	107	0
1-2:00	8	115	0	8	115	0
2-3:00	8	123	0	8	123	0
3-4:00	8	131	0	8	131	0
4-5:00	4	135	0	4	135	0
5-6:00	4	139	0	4	139	0
6-7:00	0	139	0	0	139	0
7-8:00	0	139	0	0	139	0

Total waiting time = 30  
Maximum queue = 15

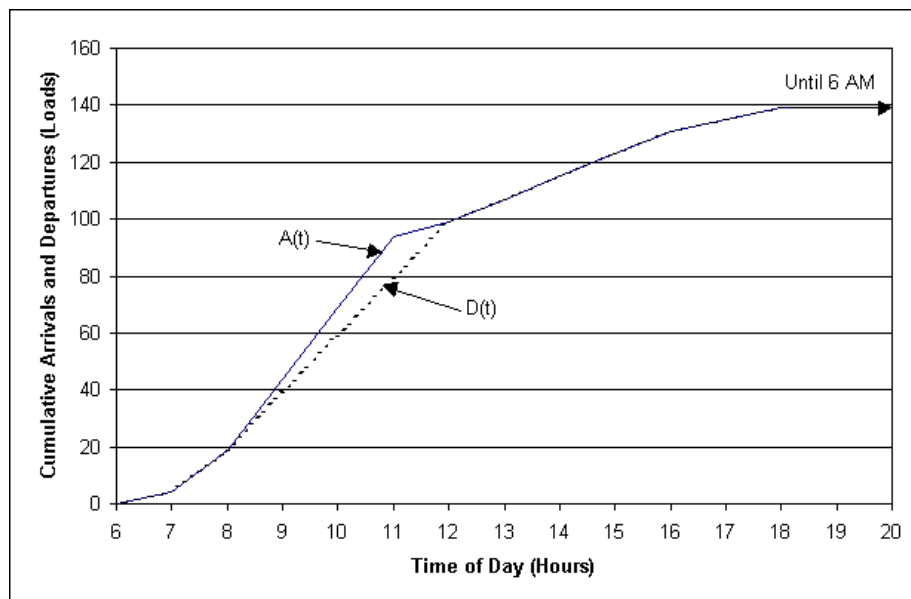

**Figure 4-10:** Delay of Lift Loads on a Building Site[Back to top](#)

## 4.14 References

1. Bourdon, C.C., and R.W. Levitt, *Union and Open Shop Construction*, Lexington Books, D.C. Heath and Co., Lexington, MA, 1980.
2. *Caterpillar Performance Handbook*, 18<sup>th</sup> Edition, Caterpillar, Inc., Peoria, IL, 1987.
3. Cordell, R.H., "Construction Productivity Management," *Cost Engineering*, Vol. 28, No. 2, February 1986, pp. 14-23.
4. Lange, J.E., and D.Q. Mills, *The Construction Industry*, Lexington Books, D.C. Heath and Co., Lexington, MA, 1979.
5. Nunnally, S.W., *Construction Methods and Management*, Prentice-Hall, Englewood Cliffs, NJ, 2nd Ed., 1987.
6. Peurifoy, R.L., *Construction Planning, Equipment and Methods*, 2nd Edition, McGraw-Hill, New York, 1970.
7. Tersine, R.J., *Principles of Inventory and Materials Management*, North Holland, New York, 1982.

[Back to top](#)

## 4.15 Problems

1. Using the relationship between the productivity index and job size in Example 4-1, determine the labor productivity for a new job requiring 350,000 labor hours under otherwise the same set of work conditions.
2. The potential labor hours available for a large energy complex were found to be 5.4 million hours. The non-productive activities expressed in thousands of labor hours were:
  1. 360 for holidays and strikes
  2. 1,152 for absentees
  3. 785 for temporary stoppage
  4. 1,084 for indirect labor

Determine the productive labor yield after the above factors are taken into consideration.

3. Labor productivity at job site is known to decrease with overtime work. Let  $x$  be the percentage of overtime over normal work week. If  $x$  is expressed in decimals, the productivity index  $I$  as a function of the percentage of overtime is found to be:

$$I = -0.8x^2 + 1 \quad 0 \leq x \leq 0.5$$

Find the value of the index  $I$  for  $x = 0, 0.1, 0.2, 0.3, 0.4$  and  $0.5$  and plot the relationship in a graph.

4. Labor productivity for a complex project is known to increase gradually in the first 500,000 labor hours because of the learning effects. Let  $x$  be the number of 100,000 labor hours. The labor productivity index  $I$  is found to be a function of  $x$  as follows:

$$I = \begin{cases} -0.016x^2 + 0.16x + 0.6 & \text{for } 0 < x \leq 5 \\ 1.0 & \text{for } x \geq 5 \end{cases}$$

Find the value of the index  $I$  for  $x = 0, 1, 2, 3, 4$  and  $5$  and plot the relationship in a graph.

5. The probabilities for different delivery times of an item are given in the table below. Find the expected delivery date of the item. Also find the lead time required to provide an expected delivery date one day less than the desired delivery date.

$t$	$p(t)$	$Pr\{T \leq t\}$
12	0.05	0.05
13	0.10	0.15
14	0.25	0.40
15	0.35	0.75
16	0.15	0.90
17	0.10	1.00

6. A power shovel with a dipper of two cubic yard capacity has a standard operating cycle time of 80 seconds. The excavated material which has a swell factor of 1.05 will be disposed by a dump truck with an 8 cubic yard capacity at a dump site 6 miles away. The average speed of the dump truck is 30 mph and the dumping time is 40 seconds. Find the daily standard production rates of the power shovel and the dump truck if both are operated 8 hours per day. Determine also the number of trucks needed daily to dispose of the excavated material.
7. The power shovel in Problem P6 has a daily standard production rate of 720 cubic yards. Determine the job site productivity and the

actual cycle time of this shovel under the work conditions at the site that affect the productivity as shown below:

Work conditions at site	Factors
Bulk composition	0.972
Soil properties and water content	0.960
Equipment idle time for breaks	0.750
Management inefficiency	0.750

8. Based on the information given for Problems P4-6 and P4-7, find the job site productivity of a dump truck, assuming that the only factors affecting work conditions are 0.85 for equipment idle time and 0.80 for management efficiency. Also find the number of dump trucks required.
9. A Power shovel with a dipper of 1.5 cubic yard capacity has a standard operating cycle time of 60 seconds. The excavated material which has a swell factor of 1.08 will be disposed by a dump truck with a 7.5 cubic yard capacity at a dumpsite 5 miles away. The average speed of a dump truck is 25 mph and the dumping time is 75 seconds. Both the power shovel and the dump truck are operated 8 hours per day.
  1. Find the daily standard production rate of the power shovel.
  2. Find the daily standard production rate of the dump truck and number of trucks required.
  3. If the work conditions at the site that affect the productivity of the shovel can be represented by four factors  $F_1 = 0.940$ ,  $F_2 = 0.952$ ,  $F_3 = 0.850$  and  $F_4 = 0.750$ , determine the job-site productivity and the actual cycle time.
  4. If the work conditions at the site affect the productivity of the dump truck can be represented by three factors  $F_1 = 0.952$ ,  $F_2 = 0.700$  and  $F_3 = 0.750$ , determine the job site productivity of the dump truck, and the number of dump trucks required.
10. Suppose that a single piece of equipment is available on a site for testing joints. Further, suppose that each joint has to be tested and certified before work can proceed. Joints are completed and ready for testing at random intervals during a shift. Each test requires an average of ten minutes. What is the average utilization of the testing equipment and the average wait of a completed joint for testing if the number of joints completed is (a) five per hour or (b) three per hour.
11. Suppose that the steel plates to be inspected are arriving steadily at a rate of one every twelve minutes. Each inspection requires sixteen minutes, but two inspectors are available so the inspection service rate is one every eight minutes. Suppose one inspector takes a break for sixty minutes. What is the resulting delay in the arriving pieces? What is the average delay among the pieces that have to wait?
12. Suppose that three machines are available in a fabrication shop for testing welded joints of structural members so that the testing service rate of the three machines is one in every 20 minutes. However, one of the three machines is shut down for 90 minutes when the welded joints to be tested arrive at a rate of one in every 25 minutes. What is the total delay for the testing service of the arriving joints? What is the average delay? Sketch the cumulative arrivals and services versus time.
13. Solve Example 4-17 if each lift requires 5 minutes instead of 3 minutes.
14. Solve Example 4-17 if each lift requires 6 minutes instead of 3 minutes
15. Suppose that up to 12 customers can be served per hour in an automated inspection process. What is the total waiting time and maximum queue with arrival rates for both cases (a) and (b) below:

	(a)	(b)
6-7:00 am	0	0
7-8:00	25	10
8-9:00	25	10
9-10:00 am	25	15
10-11:00 am	25	15
11-12:00 am	10	10
12-1:00 pm	8	15
1-2:00 pm	0	15
2-3:00 pm	0	10
3-4:00 pm	0	10
4-5:00 pm	0	10
After 5 pm	0	0
Total number of arrivals	118	120

16. For the list of labor characteristic qualities in Section 4.3 (beginning with Quality of Work and ending with Diversity), rate your own job performance on the three point scale given.



[Back to top](#)

## 4.16 Footnotes

1. McCullough, David, *The Path Between the Seas*, Simon and Schuster, 1977, pg. 531. ([Back](#))
2. Rosefielde, Steven and Daniel Quinn Mills, "Is Construction Technologically Stagnant?", in Lange, Julian E. and Daniel Quinn Mills, *The Construction Industry*, Lexington Books, 1979, pg. 83. ([Back](#))
3. This example was adapted with permission from an unpublished paper "Managing Mega Projects" presented by G.R. Desnoyers at the Project Management Symposium sponsored by the Exxon Research and Engineering Company, Florham Park, NJ, November 12, 1980. ([Back](#))
4. See R.L. Tucker, "Perfection of the Buggy Whip," The Construction Advancement Address, ASCE, Boston, MA, Oct. 29, 1986. ([Back](#))
5. For more detailed discussion, see D.G. Mills: "Labor Relations and Collective Bargaining" (Chapter 4) in *The Construction Industry* (by J.E. Lang and D.Q. Mills), Lexington Books, D.C. Heath and Co., Lexington, MA, 1979. ([Back](#))
6. This example was adapted from Stukhart, G. and Bell, L.C. "Costs and Benefits of Materials Management Systems," *ASCE Journal of Construction Engineering and Management*, Vol. 113, No. 2, June 1987, pp. 222-234. ([Back](#))
7. The information for this example was provided by Exxon Pipeline Company, Houston, Texas, with permission from the Alyeska Pipeline Service Co., Anchorage, Alaska. ([Back](#))
8. This example was adapted from A.E. Kerridge, "How to Develop a Project Schedule," in A.E. Kerridge and C. H. Vervalin (eds.), *Engineering and Construction Project Management*, Gulf Publishing Company, Houston, 1986. ([Back](#))
9. For further details on equipment characteristics, see, for example, S.W. Nunnally, *Construction Methods and Management*, Second Edition, Prentice-Hall, 1986 ([Back](#))
10. See Paulson, C., "Automation and Robotics for Construction," *ASCE Journal of Construction Engineering and Management*, Vol. 111, No. CO-3, 1985, pp. 190-207. ([Back](#))
11. This example is adapted from Fred Moavenzadeh, "Construction's High-Technology Revolution," *Technology Review*, October, 1985, pg. 32. ([Back](#))
12. This and the following examples in this section have been adapted from E. Baracco-Miller and C.T. Hendrickson, *Planning for Construction*, Technical Report No. R-87-162, Department of Civil Engineering, Carnegie Mellon University, Pittsburgh, PA 1987. ([Back](#))
13. This model used the INSIGHT simulation language and was described in B.C. Paulson, W.T. Chan, and C.C. Koo, "Construction Operations Simulation by Microcomputer," *ASCE Journal of Construction Engineering and Management*, Vol. 113, No. CO-2, June 1987, pp. 302-314. ([Back](#))
14. In the literature of queueing theory, this formula represents an M/D/1 queue, meaning that the arrival process is Markovian or random, the service time is fixed, only one server exists, and the system is in "steady state," implying that the service time and average arrival rate are constant. Altering these assumptions would require changes in the waiting time formula; for example, if service times were also random, the waiting time formula would not have the 2 shown in the denominator of Eq. (4.27). For more details on queueing systems, see Newell, G.F. *Applications of Queueing Theory*, Chapman and Hall, London, 1982. ([Back](#))

[Previous Chapter](#) | [Table of Contents](#) | [Next Chapter](#)

<a href="#">Go Up to Table of Contents</a>	
<a href="#">Go To Chapter 4 (Labor, Material and Equipment Utilization)</a>	<a href="#">Go To Chapter 6 (Economic Evaluation of Facility Investments)</a>
<i>Cost Estimation</i> <a href="#">Costs Associated with Constructed Facilities</a> <a href="#">Approaches to Cost Estimation</a> <a href="#">Type of Construction Cost Estimates</a> <a href="#">Effects of Scale on Construction Cost</a> <a href="#">Unit Cost Method of Estimation</a> <a href="#">Methods for Allocation of Joint Costs</a> <a href="#">Historical Cost Data</a> <a href="#">Cost Indices</a> <a href="#">Applications of Cost Indices to Estimating</a> <a href="#">Estimate Based on Engineer's List of Quantities</a> <a href="#">Allocation of Construction Costs Over Time</a> <a href="#">Computer Aided Cost Estimation</a> <a href="#">Estimation of Operating Costs</a> <a href="#">References</a> <a href="#">Problems</a> <a href="#">Footnotes</a>	

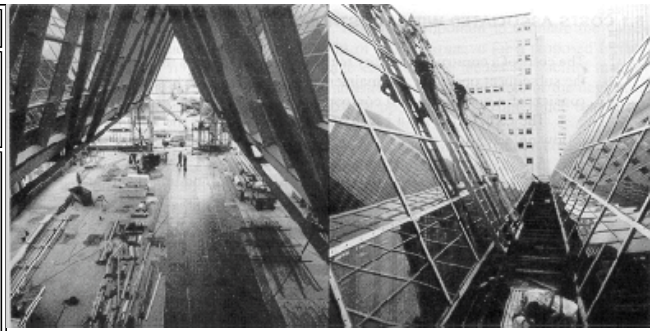

[http://pmbook.ce.cmu.edu/05\\_Cost\\_Estimation.html](http://pmbook.ce.cmu.edu/05_Cost_Estimation.html)

## 5. Cost Estimation

### 5.1 Costs Associated with Constructed Facilities

The costs of a constructed facility to the owner include both the initial capital cost and the subsequent operation and maintenance costs. Each of these major cost categories consists of a number of cost components.

The capital cost for a construction project includes the expenses related to the initial establishment of the facility:

- Land acquisition, including assembly, holding and improvement
- Planning and feasibility studies
- Architectural and engineering design
- Construction, including materials, equipment and labor
- Field supervision of construction
- Construction financing
- Insurance and taxes during construction
- Owner's general office overhead
- Equipment and furnishings not included in construction
- Inspection and testing

The operation and maintenance cost in subsequent years over the project life cycle includes the following expenses:

- Land rent, if applicable
- Operating staff
- Labor and material for maintenance and repairs
- Periodic renovations
- Insurance and taxes
- Financing costs
- Utilities
- Owner's other expenses

The magnitude of each of these cost components depends on the nature, size and location of the project as well as the management organization, among many considerations. The owner is interested in achieving the lowest possible overall project cost that is consistent with its investment objectives.

It is important for design professionals and construction managers to realize that while the construction cost may be the single largest component of the capital cost, other cost components are not insignificant. For example, land acquisition costs are a

major expenditure for building construction in high-density urban areas, and construction financing costs can reach the same order of magnitude as the construction cost in large projects such as the construction of nuclear power plants.

From the owner's perspective, it is equally important to estimate the corresponding operation and maintenance cost of each alternative for a proposed facility in order to analyze the life cycle costs. The large expenditures needed for facility maintenance, especially for publicly owned infrastructure, are reminders of the neglect in the past to consider fully the implications of operation and maintenance cost in the design stage.

In most construction budgets, there is an allowance for contingencies or unexpected costs occurring during construction. This contingency amount may be included within each cost item or be included in a single category of construction contingency. The amount of contingency is based on historical experience and the expected difficulty of a particular construction project. For example, one construction firm makes estimates of the expected cost in five different areas:

- Design development changes,
- Schedule adjustments,
- General administration changes (such as wage rates),
- Differing site conditions for those expected, and
- Third party requirements imposed during construction, such as new permits.

Contingent amounts not spent for construction can be released near the end of construction to the owner or to add additional project elements.

In this chapter, we shall focus on the estimation of construction cost, with only occasional reference to other cost components. In Chapter 6, we shall deal with the economic evaluation of a constructed facility on the basis of both the capital cost and the operation and maintenance cost in the life cycle of the facility. It is at this stage that tradeoffs between operating and capital costs can be analyzed.

#### Example 5-1: Energy project resource demands [\[1\]](#)

The resources demands for three types of major energy projects investigated during the energy crisis in the 1970's are shown in Table 5-1. These projects are: (1) an oil shale project with a capacity of 50,000 barrels of oil product per day; (2) a coal gasification project that makes gas with a heating value of 320 billions of British thermal units per day, or equivalent to about 50,000 barrels of oil product per day; and (3) a tar sand project with a capacity of 150,000 barrels of oil product per day.

For each project, the cost in billions of dollars, the engineering manpower requirement for basic design in thousands of hours, the engineering manpower requirement for detailed engineering in millions of hours, the skilled labor requirement for construction in millions of hours and the material requirement in billions of dollars are shown in Table 5-1. To build several projects of such an order of magnitude concurrently could drive up the costs and strain the availability of all resources required to complete the projects. Consequently, cost estimation often represents an exercise in professional judgment instead of merely compiling a bill of quantities and collecting cost data to reach a total estimate mechanically.

**TABLE 5-1** Resource Requirements of Some Major Energy Projects

	Oil shale (50,000 barrels/day)	Coal gasification (320 billions BTU/day)	Tar Sands (150,000 barrels/day)
Cost (\$ billion)	2.5	4	8 to 10
Basic design (Thousands of hours)	80	200	100
Detailed engineering (Millions of hours)	3 to 4	4 to 5	6 to 8
Construction (Millions of hours)	20	30	40
Materials (\$ billion)	1	2	2.5

Source: Exxon Research and Engineering Company, Florham Park, NJ

[Back to top](#)

## 5.2 Approaches to Cost Estimation

Cost estimating is one of the most important steps in project management. A cost estimate establishes the base line of the project cost at different stages of development of the project. A cost estimate at a given stage of project development represents a prediction provided by the cost engineer or estimator on the basis of available data. According to the American Association of Cost Engineers, cost engineering is defined as that area of engineering practice where engineering judgment and experience are utilized in the application of scientific principles and techniques to the problem of cost estimation, cost control and profitability.

Virtually all cost estimation is performed according to one or some combination of the following basic approaches:

**Production function.** In microeconomics, the relationship between the output of a process and the necessary resources is referred to as the production function. In construction, the production function may be expressed by the relationship between the volume of construction and a factor of production such as labor or capital. A production function relates the amount or volume of output to the various inputs of labor, material and equipment. For example, the amount of output  $Q$  may be derived as a function of various input factors  $x_1, x_2, \dots, x_n$  by means of mathematical and/or statistical methods. Thus, for a specified level of output, we may attempt to find a set of values for the input factors so as to minimize the production cost. The relationship between the size of a building project (expressed in square feet) to the input labor (expressed in labor hours per square foot) is an example of a production function for construction. Several such production functions are shown in Figure 3-3 of Chapter 3.

**Empirical cost inference.** Empirical estimation of cost functions requires statistical techniques which relate the cost of constructing or operating a facility to a few important characteristics or attributes of the system. The role of statistical inference is to estimate the best parameter values or constants in an assumed cost function. Usually, this is accomplished by means of regression analysis techniques.

**Unit costs for bill of quantities.** A unit cost is assigned to each of the facility components or tasks as represented by the bill of quantities. The total cost is the summation of the products of the quantities multiplied by the corresponding unit costs. The unit cost method is straightforward in principle but quite laborious in application. The initial step is to break down or disaggregate a process into a number of tasks. Collectively, these tasks must be completed for the construction of a facility. Once these tasks are defined and quantities representing these tasks are assessed, a unit cost is assigned to each and then the total cost is determined by summing the costs incurred in each task. The level of detail in decomposing into tasks will vary considerably from one estimate to another.

**Allocation of joint costs.** Allocations of cost from existing accounts may be used to develop a cost function of an operation. The basic idea in this method is that each expenditure item can be assigned to particular characteristics of the operation. Ideally, the allocation of joint costs should be causally related to the category of basic costs in an allocation process. In many instances, however, a causal relationship between the allocation factor and the cost item cannot be identified or may not exist. For example, in construction projects, the accounts for basic costs may be classified according to (1) labor, (2) material, (3) construction equipment, (4) construction supervision, and (5) general office overhead. These basic costs may then be allocated proportionally to various tasks which are subdivisions of a project.

[Back to top](#)

## 5.3 Types of Construction Cost Estimates

Construction cost constitutes only a fraction, though a substantial fraction, of the total project cost. However, it is the part of the cost under the control of the construction project manager. The required levels of accuracy of construction cost estimates vary at different stages of project development, ranging from ball park figures in the early stage to fairly reliable figures for budget control prior to construction. Since design decisions made at the beginning stage of a project life cycle are more tentative than those made at a later stage, the cost estimates made at the earlier stage are expected to be less accurate. Generally, the accuracy of a cost estimate will reflect the information available at the time of estimation.

Construction cost estimates may be viewed from different perspectives because of different institutional requirements. In spite of the many types of cost estimates used at different stages of a project, cost estimates can best be classified into three major categories according to their functions. A construction cost estimate serves one of the three basic functions: design, bid and control. For establishing the financing of a project, either a design estimate or a bid estimate is used.

1. **Design Estimates.** For the owner or its designated design professionals, the types of cost estimates encountered run

parallel with the planning and design as follows:

- Screening estimates (or order of magnitude estimates)
- Preliminary estimates (or conceptual estimates)
- Detailed estimates (or definitive estimates)
- Engineer's estimates based on plans and specifications

For each of these different estimates, the amount of design information available typically increases.

2. **Bid Estimates.** For the contractor, a bid estimate submitted to the owner either for competitive bidding or negotiation consists of direct construction cost including field supervision, plus a markup to cover general overhead and profits. The direct cost of construction for bid estimates is usually derived from a combination of the following approaches.
  - Subcontractor quotations
  - Quantity takeoffs
  - Construction procedures.
3. **Control Estimates.** For monitoring the project during construction, a control estimate is derived from available information to establish:
  - Budget estimate for financing
  - Budgeted cost after contracting but prior to construction
  - Estimated cost to completion during the progress of construction.

## Design Estimates

In the planning and design stages of a project, various design estimates reflect the progress of the design. At the very early stage, the *screening estimate* or *order of magnitude* estimate is usually made before the facility is designed, and must therefore rely on the cost data of similar facilities built in the past. A *preliminary estimate* or *conceptual estimate* is based on the conceptual design of the facility at the state when the basic technologies for the design are known. The *detailed estimate* or *definitive estimate* is made when the scope of work is clearly defined and the detailed design is in progress so that the essential features of the facility are identifiable. The *engineer's estimate* is based on the completed plans and specifications when they are ready for the owner to solicit bids from construction contractors. In preparing these estimates, the design professional will include expected amounts for contractors' overhead and profits.

The costs associated with a facility may be decomposed into a hierarchy of levels that are appropriate for the purpose of cost estimation. The level of detail in decomposing the facility into tasks depends on the type of cost estimate to be prepared. For conceptual estimates, for example, the level of detail in defining tasks is quite coarse; for detailed estimates, the level of detail can be quite fine.

As an example, consider the cost estimates for a proposed bridge across a river. A screening estimate is made for each of the potential alternatives, such as a tied arch bridge or a cantilever truss bridge. As the bridge type is selected, e.g. the technology is chosen to be a tied arch bridge instead of some new bridge form, a preliminary estimate is made on the basis of the layout of the selected bridge form on the basis of the preliminary or conceptual design. When the detailed design has progressed to a point when the essential details are known, a detailed estimate is made on the basis of the well defined scope of the project. When the detailed plans and specifications are completed, an engineer's estimate can be made on the basis of items and quantities of work.

## Bid Estimates

The contractor's bid estimates often reflect the desire of the contractor to secure the job as well as the estimating tools at its disposal. Some contractors have well established cost estimating procedures while others do not. Since only the lowest bidder will be the winner of the contract in most bidding contests, any effort devoted to cost estimating is a loss to the contractor who is not a successful bidder. Consequently, the contractor may put in the least amount of possible effort for making a cost estimate if it believes that its chance of success is not high.

If a general contractor intends to use subcontractors in the construction of a facility, it may solicit price quotations for various tasks to be subcontracted to specialty subcontractors. Thus, the general contractor will shift the burden of cost estimating to subcontractors. If all or part of the construction is to be undertaken by the general contractor, a bid estimate may be prepared on the basis of the quantity takeoffs from the plans provided by the owner or on the basis of the construction procedures devised by the contractor for implementing the project. For example, the cost of a footing of a certain type and size may be found in commercial publications on cost data which can be used to facilitate cost estimates from quantity takeoffs. However, the contractor may want to assess the actual cost of construction by considering the actual construction procedures to be used and the associated costs if the project is deemed to be different from typical designs. Hence, items such as labor, material and equipment needed to perform various tasks may be used as parameters for the cost estimates.

## Control Estimates

Both the owner and the contractor must adopt some base line for cost control during the construction. For the owner, a *budget estimate* must be adopted early enough for planning long term financing of the facility. Consequently, the detailed estimate is often used as the budget estimate since it is sufficient definitive to reflect the project scope and is available long before the engineer's estimate. As the work progresses, the budgeted cost must be revised periodically to reflect the estimated cost to completion. A revised estimated cost is necessary either because of change orders initiated by the owner or due to unexpected cost overruns or savings.

For the contractor, the bid estimate is usually regarded as the budget estimate, which will be used for control purposes as well as for planning construction financing. The budgeted cost should also be updated periodically to reflect the estimated cost to completion as well as to insure adequate cash flows for the completion of the project.

### Example 5-2: Screening estimate of a grouting seal beneath a landfill [2]

One of the methods of isolating a landfill from groundwater is to create a bowl-shaped bottom seal beneath the site as shown in Figure 5-0. The seal is constructed by pumping or pressure-injecting grout under the existing landfill. Holes are bored at regular intervals throughout the landfill for this purpose and the grout tubes are extended from the surface to the bottom of the landfill. A layer of soil at a minimum of 5 ft. thick is left between the grouted material and the landfill contents to allow for irregularities in the bottom of the landfill. The grout liner can be between 4 and 6 feet thick. A typical material would be Portland cement grout pumped under pressure through tubes to fill voids in the soil. This grout would then harden into a permanent, impermeable liner.

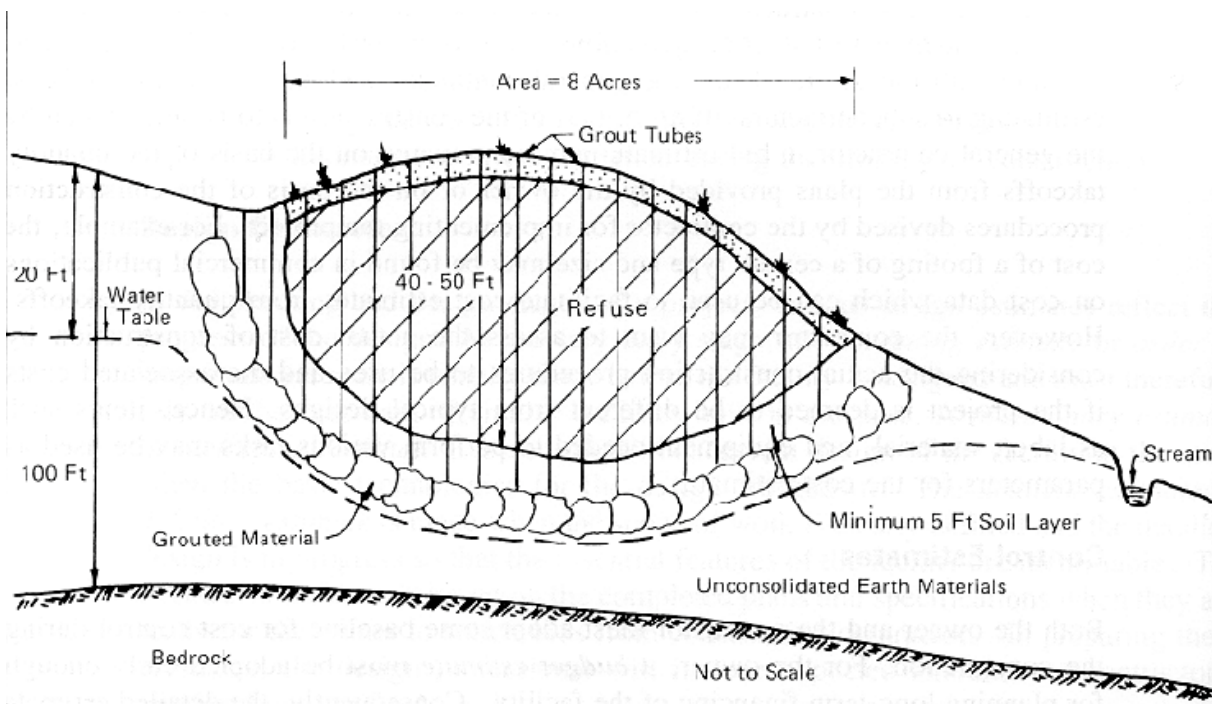

**Figure 5-1: Grout Bottom Seal Liner at a Landfill**

The work items in this project include (1) drilling exploratory bore holes at 50 ft intervals for grout tubes, and (2) pumping grout into the voids of a soil layer between 4 and 6 ft thick. The quantities for these two items are estimated on the basis of the landfill area:

$$8 \text{ acres} = (8)(43,560 \text{ ft}^2/\text{acre}) = 348,480 \text{ ft}^2$$

(As an approximation, use 360,000 ft<sup>2</sup> to account for the bowl shape)

The number of bore holes in a 50 ft by 50 ft grid pattern covering 360,000 ft<sup>2</sup> is given by:

$$\frac{3600,000 \text{ ft}^2}{(50 \text{ ft})(50 \text{ ft})} = 144$$

The average depth of the bore holes is estimated to be 20 ft. Hence, the total amount of drilling is  $(144)(20) = 2,880$  ft.

The volume of the soil layer for grouting is estimated to be:

$$\begin{aligned} \text{for a 4 ft layer, volume} &= (4 \text{ ft})(360,000 \text{ ft}^2) = 1,440,000 \text{ ft}^3 \\ \text{for a 6 ft layer, volume} &= (6 \text{ ft})(360,000 \text{ ft}^2) = 2,160,000 \text{ ft}^3 \end{aligned}$$

It is estimated from soil tests that the voids in the soil layer are between 20% and 30% of the total volume. Thus, for a 4 ft soil layer:

$$\begin{aligned} \text{grouting in 20\% voids} &= (20\%)(1,440,000) = 288,000 \text{ ft}^3 \\ \text{grouting in 30\% voids} &= (30\%)(1,440,000) = 432,000 \text{ ft}^3 \end{aligned}$$

and for a 6 ft soil layer:

$$\begin{aligned} \text{grouting in 20\% voids} &= (20\%)(2,160,000) = 432,000 \text{ ft}^3 \\ \text{grouting in 30\% voids} &= (30\%)(2,160,000) = 648,000 \text{ ft}^3 \end{aligned}$$

The unit cost for drilling exploratory bore holes is estimated to be between \$3 and \$10 per foot (in 1978 dollars) including all expenses. Thus, the total cost of boring will be between  $(2,880)(3) = \$ 8,640$  and  $(2,880)(10) = \$28,800$ . The unit cost of Portland cement grout pumped into place is between \$4 and \$10 per cubic foot including overhead and profit. In addition to the variation in the unit cost, the total cost of the bottom seal will depend upon the thickness of the soil layer grouted and the proportion of voids in the soil. That is:

$$\begin{aligned} \text{for a 4 ft layer with 20\% voids, grouting cost} &= \$1,152,000 \text{ to } \$2,880,000 \\ \text{for a 4 ft layer with 30\% voids, grouting cost} &= \$1,728,000 \text{ to } \$4,320,000 \\ \text{for a 6 ft layer with 20\% voids, grouting cost} &= \$1,728,000 \text{ to } \$4,320,000 \\ \text{for a 6 ft layer with 30\% voids, grouting cost} &= \$2,592,000 \text{ to } \$6,480,000 \end{aligned}$$

The total cost of drilling bore holes is so small in comparison with the cost of grouting that the former can be omitted in the screening estimate. Furthermore, the range of unit cost varies greatly with soil characteristics, and the engineer must exercise judgment in narrowing the range of the total cost. Alternatively, additional soil tests can be used to better estimate the unit cost of pumping grout and the proportion of voids in the soil. Suppose that, in addition to ignoring the cost of bore holes, an average value of a 5 ft soil layer with 25% voids is used together with a unit cost of \$ 7 per cubic foot of Portland cement grouting. In this case, the total project cost is estimated to be:

$$(5 \text{ ft})(360,000 \text{ ft}^2)(25\%)(\$7/\text{ft}^3) = \$3,150,000$$

An important point to note is that this screening estimate is based to a large degree on engineering judgment of the soil characteristics, and the range of the actual cost may vary from \$ 1,152,000 to \$ 6,480,000 even though the probabilities of having actual costs at the extremes are not very high.

### Example 5-3: Example of engineer's estimate and contractors' bids<sup>[3]</sup>

The engineer's estimate for a project involving 14 miles of Interstate 70 roadway in Utah was \$20,950,859. Bids were submitted on March 10, 1987, for completing the project within 320 working days. The three low bidders were:

1. Ball, Ball & Brosame, Inc., Danville CA	\$14,129,798
2. National Projects, Inc., Phoenix, AR	\$15,381,789
3. Kiewit Western Co., Murray, Utah	\$18,146,714

It was astounding that the winning bid was 32% below the engineer's estimate. Even the third lowest bidder was 13% below the engineer's estimate for this project. The disparity in pricing can be attributed either to the very conservative estimate of the engineer in the Utah Department of Transportation or to area contractors who are hungrier than usual to win jobs.

The unit prices for different items of work submitted for this project by (1) Ball, Ball & Brosame, Inc. and (2) National Projects, Inc. are shown in Table 5-2. The similarity of their unit prices for some items and the disparity in others submitted by the two contractors can be noted.

**TABLE 5-2: Unit Prices in Two Contractors' Bids for Roadway Construction**

Items	Unit	Quantity	Unit price	
			1	2
Mobilization	ls	1	115,000	569,554
Removal, berm	lf	8,020	1.00	1.50
Finish subgrade	sy	1,207,500	0.50	0.30
Surface ditches	lf	525	2.00	1.00
Excavation structures	cy	7,000	3.00	5.00
Base course, untreated, 3/4"	ton	362,200	4.50	5.00
Lean concrete, 4" thick	sy	820,310	3.10	3.00
PCC, pavement, 10" thick	sy	76,010	10.90	12.00
Concrete, ci AA (AE)	ls	1	200,000	190,000
Small structure	cy	50	500	475
Barrier, precast	lf	7,920	15.00	16.00
Flatwork, 4" thick	sy	7,410	10.00	8.00
10" thick	sy	4,241	20.00	27.00
Slope protection	sy	2,104	25.00	30.00
Metal, end section, 15"	ea	39	100	125
18"	ea	3	150	200
Post, right-of-way, modification	lf	4,700	3.00	2.50
Salvage and relay pipe	lf	1,680	5.00	12.00
Loose riprap	cy	32	40.00	30.00
Braced posts	ea	54	100	110
Delineators, type I	lb	1,330	12.00	12.00
type II	ea	140	15.00	12.00
Constructive signs fixed	sf	52,600	0.10	0.40
Barricades, type III	lf	29,500	0.20	0.20
Warning lights	day	6,300	0.10	0.50
Pavement marking, epoxy material				
Black	gal	475	90.00	100
Yellow	gal	740	90.00	80.00
White	gal	985	90.00	70.00
Plowable, one-way white	ea	342	50.00	20.00
Topsoil, contractor furnished	cy	260	10.00	6.00
Seedling, method A	acr	103	150	200
Excelsior blanket	sy	500	2.00	2.00
Corrugated, metal pipe, 18"	lf	580	20.00	18.00
Polyethylene pipe, 12"	lf	2,250	15.00	13.00
Catch basin grate and frame	ea	35	350	280



Equal opportunity training	hr	18,000	0.80	0.80
Granular backfill borrow	cy	274	10.00	16.00
Drill caisson, 2'x6"	lf	722	100	80.00
Flagging	hr	20,000	8.25	12.50
Prestressed concrete member				
type IV, 141'x4"	ea	7	12,000	16.00
132'x4"	ea	6	11,000	14.00
Reinforced steel	lb	6,300	0.60	0.50
Epoxy coated	lb	122,241	0.55	0.50
Structural steel	ls	1	5,000	1,600
Sign, covering	sf	16	10.00	4.00
type C-2 wood post	sf	98	15.00	17.00
24"	ea	3	100	400
30"	ea	2	100	160
48"	ea	11	200	300
Auxiliary	sf	61	15.00	12.00
Steel post, 48"x60"	ea	11	500	700
type 3, wood post	sf	669	15.00	19.00
24"	ea	23	100	125
30"	ea	1	100	150
36"	ea	12	150	180
42"x60"	ea	8	150	220
48"	ea	7	200	270
Auxiliary	sf	135	15.00	13.00
Steel post	sf	1,610	40.00	35.00
12"x36"	ea	28	100	150
Foundation, concrete	ea	60	300	650
Barricade, 48"x42"	ea	40	100	100
Wood post, road closed	lf	100	30.00	36.00

[Back to top](#)

## 5.4 Effects of Scale on Construction Cost

Screening cost estimates are often based on a single variable representing the capacity or some physical measure of the design such as floor area in buildings, length of highways, volume of storage bins and production volumes of processing plants. Costs do not always vary linearly with respect to different facility sizes. Typically, scale economies or diseconomies exist. If the average cost per unit of capacity is declining, then scale economies exist. Conversely, scale diseconomies exist if average costs increase with greater size. Empirical data are sought to establish the economies of scale for various types of facility, if they exist, in order to take advantage of lower costs per unit of capacity.

Let  $x$  be a variable representing the facility capacity, and  $y$  be the resulting construction cost. Then, a linear cost relationship can be expressed in the form:

$$(5.1) \quad y = a + bx$$

where  $a$  and  $b$  are positive constants to be determined on the basis of historical data. Note that in Equation (5.1), a fixed cost of  $y = a$  at  $x = 0$  is implied as shown in Figure 5-2. In general, this relationship is applicable only in a certain range of the variable  $x$ , such as between  $x = c$  and  $x = d$ . If the values of  $y$  corresponding to  $x = c$  and  $x = d$  are known, then the cost of a facility corresponding to any  $x$  within the specified range may be obtained by linear interpolation. For example, the construction cost of a school building can be estimated on the basis of a linear relationship between cost and floor area if the unit cost per square foot of floor area is known for school buildings within certain limits of size.

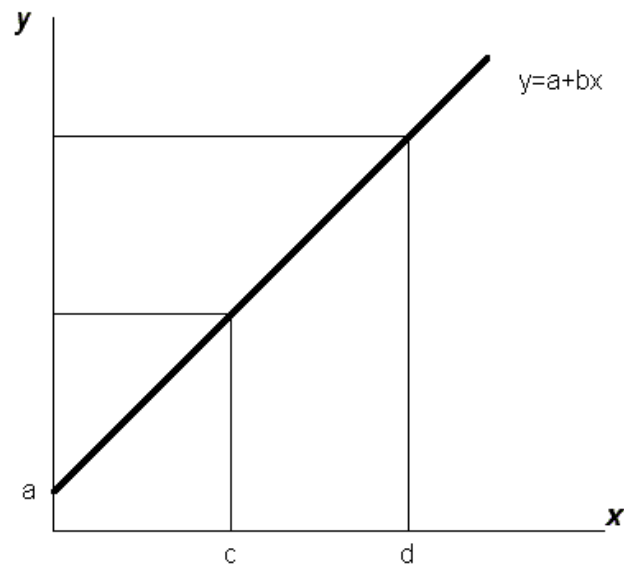
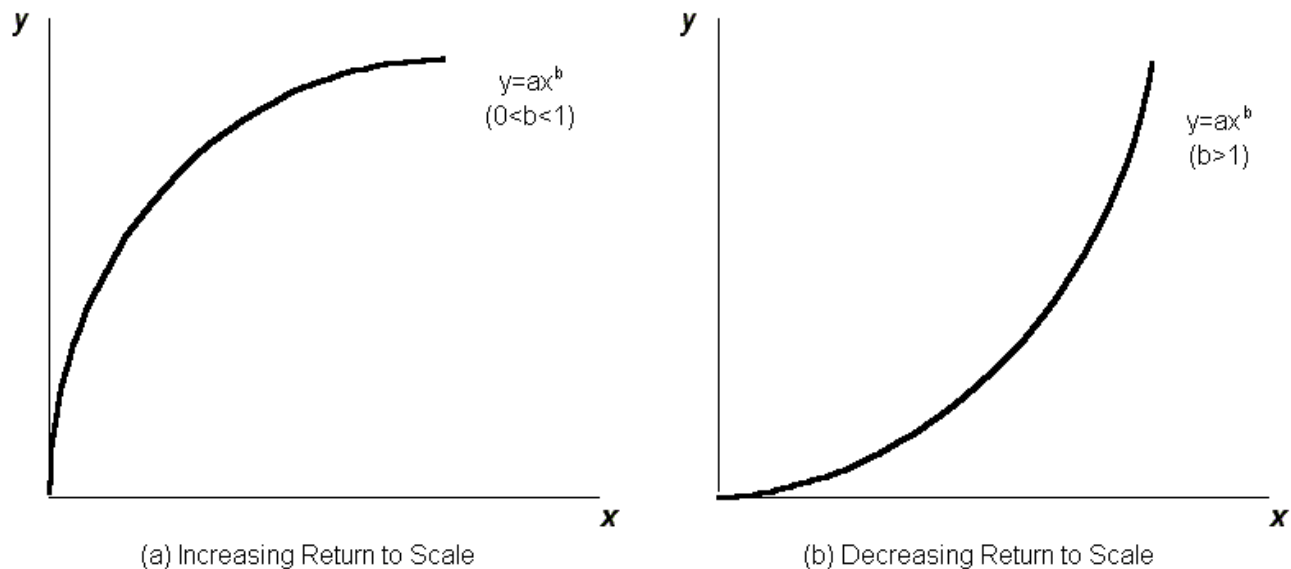

**Figure 5-2:** Linear Cost Relationship with Economies of Scale

A nonlinear cost relationship between the facility capacity  $x$  and construction cost  $y$  can often be represented in the form:

$$(5.2) \quad y = ax^b$$

where  $a$  and  $b$  are positive constants to be determined on the basis of historical data. For  $0 < b < 1$ , Equation (5.2) represents the case of increasing returns to scale, and for  $b > 1$ , the relationship becomes the case of decreasing returns to scale, as shown in Figure 5-3. Taking the logarithm of both sides this equation, a linear relationship can be obtained as follows:



**Figure 5-3:** Nonlinear Cost Relationship with increasing or Decreasing Economies of Scale

$$(5.3) \quad \ln y = \ln a + b \ln x$$

Although no fixed cost is implied in Eq.(5.2), the equation is usually applicable only for a certain range of  $x$ . The same limitation applies to Eq.(5.3). A nonlinear cost relationship often used in estimating the cost of a new industrial processing

plant from the known cost of an existing facility of a different size is known as the *exponential rule*. Let  $y_n$  be the known cost of an existing facility with capacity  $Q_n$ , and  $y$  be the estimated cost of the new facility which has a capacity  $Q$ . Then, from the empirical data, it can be assumed that:

$$(5.4) \quad y = y_n \left( \frac{Q}{Q_n} \right)^m$$

where  $m$  usually varies from 0.5 to 0.9, depending on a specific type of facility. A value of  $m = 0.6$  is often used for chemical processing plants. The exponential rule can be reduced to a linear relationship if the logarithm of Equation (5.4) is used:

$$(5.5) \quad \ln y = \ln y_n + m \ln \left( \frac{Q}{Q_n} \right)$$

or

$$(5.6) \quad \ln \left( \frac{y}{y_n} \right) = m \ln \left( \frac{Q}{Q_n} \right)$$

The exponential rule can be applied to estimate the total cost of a complete facility or the cost of some particular component of a facility.

#### Example 5-4: Determination of $m$ for the exponential rule

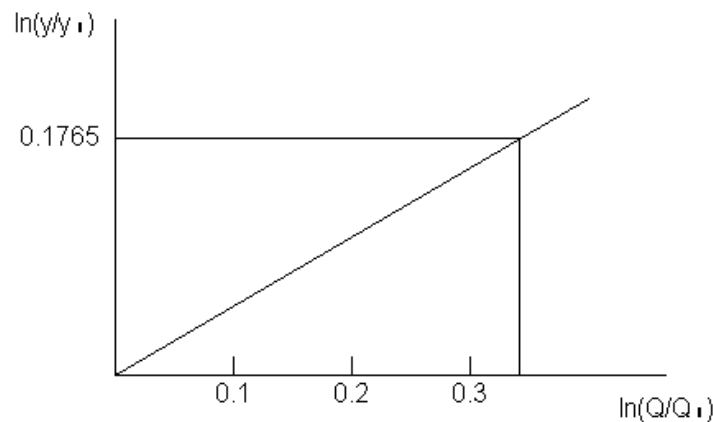

Figure 5-4: Log-Log Scale Graph of Exponential Rule Example

The empirical cost data from a number of sewage treatment plants are plotted on a log-log scale for  $\ln(Q/Q_n)$  and  $\ln(y/y_n)$  and a linear relationship between these logarithmic ratios is shown in Figure 5-4. For  $(Q/Q_n) = 1$  or  $\ln(Q/Q_n) = 0$ ,  $\ln(y/y_n) = 0$ ; and for  $Q/Q_n = 2$  or  $\ln(Q/Q_n) = 0.301$ ,  $\ln(y/y_n) = 0.1765$ . Since  $m$  is the slope of the line in the figure, it can be determined from the geometric relation as follows:

$$m = \frac{0.1765}{0.301} = 0.585$$

For  $\ln(y/y_n) = 0.1765$ ,  $y/y_n = 1.5$ , while the corresponding value of  $Q/Q_n$  is 2. In words, for  $m = 0.585$ , the cost of a plant increases only 1.5 times when the capacity is doubled.

#### Example 5-5: Cost exponents for water and wastewater treatment plants[4]

The magnitude of the cost exponent  $m$  in the exponential rule provides a simple measure of the economy of scale associated with building extra capacity for future growth and system reliability for the present in the design of treatment plants. When  $m$  is small, there is considerable incentive to provide extra capacity since scale economies exist as illustrated in Figure 5-3. When  $m$  is close to 1, the cost is directly proportional to the design capacity. The

value of  $m$  tends to increase as the number of duplicate units in a system increases. The values of  $m$  for several types of treatment plants with different plant components derived from statistical correlation of actual construction costs are shown in Table 5-3.

**TABLE 5-3** Estimated Values of Cost Exponents for Water Treatment Plants

Treatment plant type	Exponent $m$	Capacity range (millions of gallons per day)
1. Water treatment	0.67	1-100
2. Waste treatment		
Primary with digestion (small)	0.55	0.1-10
Primary with digestion (large)	0.75	0.7-100
Trickling filter	0.60	0.1-20
Activated sludge	0.77	0.1-100
Stabilization ponds	0.57	0.1-100

Source: Data are collected from various sources by P.M. Berthouex. See the references in his article for the primary sources.

**Example 5-6: Some Historical Cost Data for the Exponential Rule**

The exponential rule as represented by Equation (5.4) can be expressed in a different form as:

$$y = KQ^m$$

where

$$K = \frac{y_n}{(Q_n)^m}$$

If  $m$  and  $K$  are known for a given type of facility, then the cost  $y$  for a proposed new facility of specified capacity  $Q$  can be readily computed.

**TABLE 5-4** Cost Factors of Processing Units for Treatment Plants

Processing unit	Unit of capacity	K Value (1968 \$)	$m$ value
1. Liquid processing			
Oil separation	mgd	58,000	0.84
Hydroclone degritter	mgd	3,820	0.35
Primary sedimentation	ft <sup>2</sup>	399	0.60
Furial clarifier	ft <sup>2</sup>	700	0.57
Sludge aeration basin	mil. gal.	170,000	0.50
Tickling filter	ft <sup>2</sup>	21,000	0.71
Aerated lagoon basin	mil. gal.	46,000	0.67
Equalization	mil. gal.	72,000	0.52
Neutralization	mgd	60,000	0.70
2. Sludge handling			
Digestion	ft <sup>3</sup>	67,500	0.59
Vacuum filter	ft <sup>2</sup>	9,360	0.84

Centrifuge	lb dry solids/hr	318	0.81
------------	---------------------	-----	------

Source: Data are collected from various sources by P.M. Berthouex. See the references in his article for the primary sources.

The estimated values of K and m for various water and sewage treatment plant components are shown in Table 5-4. The K values are based on 1968 dollars. The range of data from which the K and m values are derived in the primary sources should be observed in order to use them in making cost estimates.

As an example, take  $K = \$399$  and  $m = 0.60$  for a primary sedimentation component in Table 5-4. For a proposed new plant with the primary sedimentation process having a capacity of 15,000 sq. ft., the estimated cost (in 1968 dollars) is:

$$y = (\$399)(15,000)^{0.60} = \$128,000.$$

[Back to top](#)

## 5.5 Unit Cost Method of Estimation

If the design technology for a facility has been specified, the project can be decomposed into elements at various levels of detail for the purpose of cost estimation. The unit cost for each element in the bill of quantities must be assessed in order to compute the total construction cost. This concept is applicable to both design estimates and bid estimates, although different elements may be selected in the decomposition.

For design estimates, the unit cost method is commonly used when the project is decomposed into elements at various levels of a hierarchy as follows:

1. **Preliminary Estimates.** The project is decomposed into major structural systems or production equipment items, e.g. the entire floor of a building or a cooling system for a processing plant.
2. **Detailed Estimates.** The project is decomposed into components of various major systems, i.e., a single floor panel for a building or a heat exchanger for a cooling system.
3. **Engineer's Estimates.** The project is decomposed into detailed items of various components as warranted by the available cost data. Examples of detailed items are slabs and beams in a floor panel, or the piping and connections for a heat exchanger.

For bid estimates, the unit cost method can also be applied even though the contractor may choose to decompose the project into different levels in a hierarchy as follows:

1. **Subcontractor Quotations.** The decomposition of a project into subcontractor items for quotation involves a minimum amount of work for the general contractor. However, the accuracy of the resulting estimate depends on the reliability of the subcontractors since the general contractor selects one among several contractor quotations submitted for each item of subcontracted work.
2. **Quantity Takeoffs.** The decomposition of a project into items of quantities that are measured (or *taken off*) from the engineer's plan will result in a procedure similar to that adopted for a detailed estimate or an engineer's estimate by the design professional. The levels of detail may vary according to the desire of the general contractor and the availability of cost data.
3. **Construction Procedures.** If the construction procedure of a proposed project is used as the basis of a cost estimate, the project may be decomposed into items such as labor, material and equipment needed to perform various tasks in the projects.

### Simple Unit Cost Formula

Suppose that a project is decomposed into  $n$  elements for cost estimation. Let  $Q_i$  be the quantity of the  $i^{\text{th}}$  element and  $u_i$  be the corresponding unit cost. Then, the total cost of the project is given by:

$$(5.7) \quad y = \sum_{i=1}^n u_i Q_i$$

where  $n$  is the number of units. Based on characteristics of the construction site, the technology employed, or the management of the construction process, the estimated unit cost,  $u_i$  for each element may be adjusted.

## Factored Estimate Formula

A special application of the unit cost method is the "factored estimate" commonly used in process industries. Usually, an industrial process requires several major equipment components such as furnaces, towers drums and pump in a chemical processing plant, plus ancillary items such as piping, valves and electrical elements. The total cost of a project is dominated by the costs of purchasing and installing the major equipment components and their ancillary items. Let  $C_i$  be the purchase cost of a major equipment component  $i$  and  $f_i$  be a factor accounting for the cost of ancillary items needed for the installation of this equipment component  $i$ . Then, the total cost of a project is estimated by:

$$(5.8) \quad y = \sum_{i=1}^n C_i + \sum_{i=1}^n f_i C_i = \sum_{i=1}^n C_i (1 + f_i)$$

where  $n$  is the number of major equipment components included in the project. The factored method is essentially based on the principle of computing the cost of ancillary items such as piping and valves as a fraction or a multiple of the costs of the major equipment items. The value of  $C_i$  may be obtained by applying the exponential rule so the use of Equation (5.8) may involve a combination of cost estimation methods.

## Formula Based on Labor, Material and Equipment

Consider the simple case for which costs of labor, material and equipment are assigned to all tasks. Suppose that a project is decomposed into  $n$  tasks. Let  $Q_i$  be the quantity of work for task  $i$ ,  $M_i$  be the unit material cost of task  $i$ ,  $E_i$  be the unit equipment rate for task  $i$ ,  $L_i$  be the units of labor required per unit of  $Q_i$ , and  $W_i$  be the wage rate associated with  $L_i$ . In this case, the total cost  $y$  is:

$$(5.9) \quad y = \sum_{i=1}^n y_i = \sum_{i=1}^n Q_i (M_i + E_i + W_i L_i)$$

Note that  $W_i L_i$  yields the labor cost per unit of  $Q_i$ , or the labor unit cost of task  $i$ . Consequently, the units for all terms in Equation (5.9) are consistent.

### Example 5-7: Decomposition of a building foundation into design and construction elements.

The concept of decomposition is illustrated by the example of estimating the costs of a building foundation excluding excavation as shown in Table 5-5 in which the decomposed design elements are shown on horizontal lines and the decomposed contract elements are shown in vertical columns. For a design estimate, the decomposition of the project into footings, foundation walls and elevator pit is preferred since the designer can easily keep track of these design elements; however, for a bid estimate, the decomposition of the project into formwork, reinforcing bars and concrete may be preferred since the contractor can get quotations of such contract items more conveniently from specialty subcontractors.

**TABLE 5-5** Illustrative Decomposition of Building Foundation Costs

Design elements	Contract elements			Total cost
	Formwork	Rebars	Concrete	
Footings	\$5,000	\$10,000	\$13,000	\$28,000
Foundation walls	15,000	18,000	28,000	61,000
Elevator pit	<u>9,000</u>	<u>15,000</u>	<u>16,000</u>	<u>40,000</u>
Total cost	\$29,000	\$43,000	\$57,000	\$129,000

### Example 5-8: Cost estimate using labor, material and equipment rates.

For the given quantities of work  $Q_i$  for the concrete foundation of a building and the labor, material and equipment rates in Table 5-6, the cost estimate is computed on the basis of Equation (5.9). The result is tabulated in the last

column of the same table.

**TABLE 5-6** Illustrative Cost Estimate Using Labor, Material and Equipment Rates

Description	Quantity $Q_i$	Material unit cost $M_i$	Equipment unit cost $E_i$	Wage rate $W_i$	Labor input $L_i$	Labor unit cost $W_i L_i$	Direct cost $Y_i$
Formwork	12,000 ft <sup>2</sup>	\$0.4/ft <sup>2</sup>	\$0.8/ft <sup>2</sup>	\$15/hr	0.2 hr/ft <sup>2</sup>	\$3.0/ft <sup>2</sup>	\$50,400
Rebars	4,000 lb	0.2/lb	0.3/lb	15/hr	0.04 hr/lb	0.6/lb	4,440
Concrete	500 yd <sup>3</sup>	5.0/yd <sup>3</sup>	50/yd <sup>3</sup>	15/hr	0.8 hr/yd <sup>3</sup>	12.0/yd <sup>3</sup>	<u>33,500</u>
Total							\$88,300

[Back to top](#)

## 5.6 Methods for Allocation of Joint Costs

The principle of allocating joint costs to various elements in a project is often used in cost estimating. Because of the difficulty in establishing casual relationship between each element and its associated cost, the joint costs are often prorated in proportion to the basic costs for various elements.

One common application is found in the allocation of field supervision cost among the basic costs of various elements based on labor, material and equipment costs, and the allocation of the general overhead cost to various elements according to the basic and field supervision cost. Suppose that a project is decomposed into  $n$  tasks. Let  $y$  be the total basic cost for the project and  $y_i$  be the total basic cost for task  $i$ . If  $F$  is the total field supervision cost and  $F_i$  is the proration of that cost to task  $i$ , then a typical proportional allocation is:

$$(5.10) \quad F_i = F \frac{y_i}{y}$$

Similarly, let  $z$  be the total direct field cost which includes the total basic cost and the field supervision cost of the project, and  $z_i$  be the direct field cost for task  $i$ . If  $G$  is the general office overhead for proration to all tasks, and  $G_i$  is the share for task  $i$ , then

$$(5.11) \quad G_i = G \frac{z_i}{z}$$

Finally, let  $w$  be the grand total cost of the project which includes the direct field cost and the general office overhead cost charged to the project and  $w_i$  be that attributable task  $i$ . Then,

$$(5.12) \quad z = F + y = F + \sum_{i=1}^n y_i$$

and

$$(5.13) \quad w = G + z = G + \sum_{i=1}^n z_i$$

### Example 5-9: Prorated costs for field supervision and office overhead

If the field supervision cost is \$13,245 for the project in Table 5-6 (Example 5-8) with a total direct cost of \$88,300, find the prorated field supervision costs for various elements of the project. Furthermore, if the general office overhead charged to the project is 4% of the direct field cost which is the sum of basic costs and field supervision cost, find the prorated general office overhead costs for various elements of the project.

For the project,  $y = \$88,300$  and  $F = \$13,245$ . Hence:

$$z = 13,245 + 88,300 = \$101,545$$

$$G = (0.04)(101,545) = \$4,062$$

$$w = 101,545 + 4,062 = \$105,607$$

The results of the proration of costs to various elements are shown in Table 5-7.

**TABLE 5-7** Proration of Field Supervision and Office Overhead Costs

Description	Basic cost $y_i$	Allocated field supervision cost $F_i$	Total field cost $z_i$	Allocated overhead cost $G_i$	Total cost $L_i$
Formwork	\$50,400	\$7,560	\$57,960	\$2,319	\$60,279
Rebars	4,400	660	5,060	202	5,262
Concrete	<u>33,500</u>	<u>5,025</u>	<u>38,525</u>	<u>1,541</u>	<u>40,066</u>
Total	\$88,300	\$13,245	\$101,545	\$4,062	\$105,607

**Example 5-10: A standard cost report for allocating overhead**

The reliance on labor expenses as a means of allocating overhead burdens in typical management accounting systems can be illustrated by the example of a particular product's standard cost sheet. [5] Table 5-8 is an actual product's standard cost sheet of a company following the procedure of using overhead burden rates assessed per direct labor hour. The material and labor costs for manufacturing a type of valve were estimated from engineering studies and from current material and labor prices. These amounts are summarized in Columns 2 and 3 of Table 5-8. The overhead costs shown in Column 4 of Table 5-8 were obtained by allocating the expenses of several departments to the various products manufactured in these departments in proportion to the labor cost. As shown in the last line of the table, the material cost represents 29% of the total cost, while labor costs are 11% of the total cost. The allocated overhead cost constitutes 60% of the total cost. Even though material costs exceed labor costs, only the labor costs are used in allocating overhead. Although this type of allocation method is common in industry, the arbitrary allocation of joint costs introduces unintended cross subsidies among products and may produce adverse consequences on sales and profits. For example, a particular type of part may incur few overhead expenses in practice, but this phenomenon would not be reflected in the standard cost report.

**TABLE 5-8** Standard Cost Report for a Type of Valve

	(1) Material cost	(2) Labor cost	(3) Overhead cost	(4) Total cost
Purchased part	\$1.1980			\$1.1980
Operation				
Drill, face, tap (2)		\$0.0438	\$0.2404	\$0.2842
Degrease		0.0031	0.0337	0.0368
Remove burs		<u>0.0577</u>	<u>0.3241</u>	<u>0.3818</u>
Total cost, this item	1.1980	0.1046	0.5982	1.9008
Other subassemblies	<u>0.3523</u>	<u>0.2994</u>	<u>1.8519</u>	<u>2.4766</u>
Total cost, subassemblies	<u>1.5233</u>	0.4040	2.4501	4.3773
Assemble and test		0.1469	0.4987	0.6456
Pack without paper		<u>0.0234</u>	<u>0.1349</u>	<u>0.1583</u>
Total cost, this item	\$1.5233	\$0.5743	\$3.0837	\$5.1813
Cost component, %	29%	11%	60%	100%

Source: H. T. Johnson and R. S. Kaplan, *Relevance lost: The Rise and Fall of Management Accounting*, Harvard Business School Press, Boston. Reprinted with permission.

[Back to top](#)



## 5.7 Historical Cost Data

Preparing cost estimates normally requires the use of historical data on construction costs. Historical cost data will be useful for cost estimation only if they are collected and organized in a way that is compatible with future applications. Organizations which are engaged in cost estimation continually should keep a file for their own use. The information must be updated with respect to changes that will inevitably occur. The format of cost data, such as unit costs for various items, should be organized according to the current standard of usage in the organization.

Construction cost data are published in various forms by a number of organizations. These publications are useful as references for comparison. Basically, the following types of information are available:

- Catalogs of vendors' data on important features and specifications relating to their products for which cost quotations are either published or can be obtained. A major source of vendors' information for building products is *Sweets' Catalog* published by McGraw-Hill Information Systems Company.
- Periodicals containing construction cost data and indices. One source of such information is *ENR*, the McGraw-Hill Construction Weekly, which contains extensive cost data including quarterly cost reports. *Cost Engineering*, a journal of the American Society of Cost Engineers, also publishes useful cost data periodically.
- Commercial cost reference manuals for estimating guides. An example is the *Building Construction Cost Data* published annually by R.S. Means Company, Inc., which contains unit prices on building construction items. *Dodge Manual for Building Construction*, published by McGraw-Hill, provides similar information.
- Digests of actual project costs. The *Dodge Digest of Building Costs and Specifications* provides descriptions of design features and costs of actual projects by building type. Once a week, *ENR* publishes the bid prices of a project chosen from all types of construction projects.

Historical cost data must be used cautiously. Changes in relative prices may have substantial impacts on construction costs which have increased in relative price. Unfortunately, systematic changes over a long period of time for such factors are difficult to predict. Errors in analysis also serve to introduce uncertainty into cost estimates. It is difficult, of course, to foresee all the problems which may occur in construction and operation of facilities. There is some evidence that estimates of construction and operating costs have tended to persistently understate the actual costs. This is due to the effects of greater than anticipated increases in costs, changes in design during the construction process, or overoptimism.

Since the future prices of constructed facilities are influenced by many uncertain factors, it is important to recognize that this risk must be borne to some degree by all parties involved, i.e., the owner, the design professionals, the construction contractors, and the financing institution. It is to the best interest of all parties that the risk sharing scheme implicit in the design/construct process adopted by the owner is fully understood by all. When inflation adjustment provisions have very different risk implications to various parties, the price level changes will also be treated differently for various situations. [Back to top](#)

## 5.8 Cost Indices

Since historical cost data are often used in making cost estimates, it is important to note the price level changes over time. Trends in price changes can also serve as a basis for forecasting future costs. The input price indices of labor and/or material reflect the price level changes of such input components of construction; the output price indices, where available, reflect the price level changes of the completed facilities, thus to some degree also measuring the productivity of construction.

A price index is a weighted aggregate measure of constant quantities of goods and services selected for the package. The price index at a subsequent year represents a proportionate change in the same weighted aggregate measure because of changes in prices. Let  $I_t$  be the price index in year  $t$ , and  $I_{t+1}$  be the price index in the following year  $t+1$ . Then, the percent change in price index for year  $t+1$  is:

$$(5.14) \quad j_{t+1} = \frac{I_{t+1} - I_t}{I_t} (100\%)$$

or

$$(5.15) \quad I_{t+1} = I_t (1 + j_{t+1})$$

If the price index at the base year  $t=0$  is set at a value of 100, then the price indices  $I_1, I_2, \dots, I_n$  for the subsequent years  $t=1, 2, \dots, n$  can be computed successively from changes in the total price charged for the package of goods measured in the index.

The best-known indicators of general price changes are the Gross Domestic Product (GDP) deflators compiled periodically by

the U.S. Department of Commerce, and the consumer price index (CPI) compiled periodically by the U.S. Department of Labor. They are widely used as broad gauges of the changes in production costs and in consumer prices for essential goods and services. Special price indices related to construction are also collected by industry sources since some input factors for construction and the outputs from construction may disproportionately outpace or fall behind the general price indices. Examples of special price indices for construction input factors are the wholesale Building Material Price and Building Trades Union Wages, both compiled by the U.S. Department of Labor. In addition, the construction cost index and the building cost index are reported periodically in the *Engineering News-Record (ENR)*. Both ENR cost indices measure the effects of wage rate and material price trends, but they are not adjusted for productivity, efficiency, competitive conditions, or technology changes. Consequently, all these indices measure only the price changes of respective construction *input factors* as represented by constant quantities of material and/or labor. On the other hand, the price indices of various types of completed facilities reflect the price changes of construction output including all pertinent factors in the construction process. The building construction output indices compiled by Turner Construction Company and Handy-Whitman Utilities are compiled in the U.S. *Statistical Abstracts* published each year.

Figure 5-7 and Table 5-9 show a variety of United States indices, including the Gross Domestic Product (GDP) price deflator, the ENR building index, and the Turner Construction Company Building Cost Index from 1996 to 2007, using 2000 as the base year with an index of 100.

**TABLE 5-9** Summary of Input and Output Price Indices, 1996-2007

Year	1996	1997	1998	1999	2000	2001	2002	2003	2004	2005	2006	2007
Turner Construction - Buildings	84.9	88.2	92.3	95.8	100.0	103.0	104.0	104.4	110.1	120.5	133.3	143.5
ENR - Buildings	90.5	95.0	95.8	97.6	100.0	101.0	102.4	104.4	112.6	118.8	123.5	126.7
GDP Deflator	94.0	95.6	96.8	98.0	100.0	102.3	104.2	105.9	107.2	108.6	110.2	112.0

Note: Index = 100 in base year of 2000.

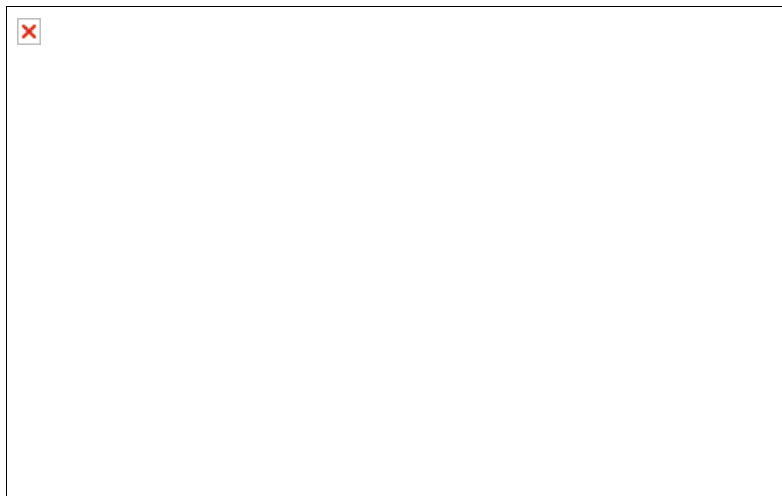

**Figure 5-7** Trends for US price indices.

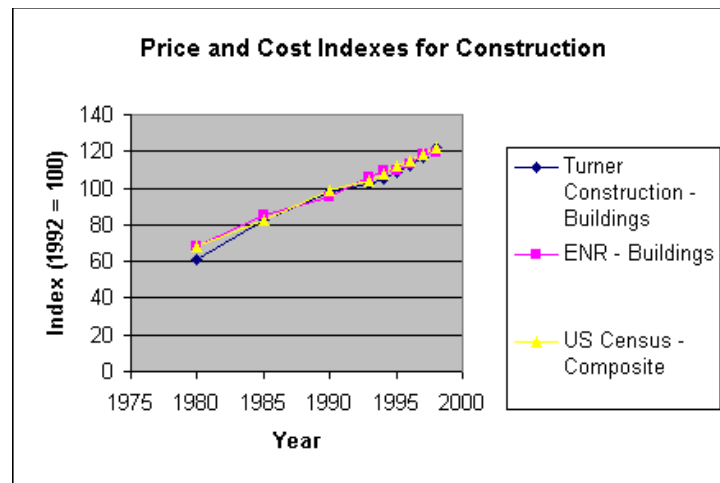

Figure 5-8 Price and cost indices for construction.

Since construction costs vary in different regions of the United States and in all parts of the world, *locational indices* showing the construction cost at a specific location relative to the national trend are useful for cost estimation. ENR publishes periodically the indices of local construction costs at the major cities in different regions of the United States as percentages of local to national costs.

When the inflation rate is relatively small, i.e., less than 10%, it is convenient to select a single price index to measure the inflationary conditions in construction and thus to deal only with a single set of price change rates in forecasting. Let  $j_t$  be the price change rate in year  $t+1$  over the price in year  $t$ . If the base year is denoted as year 0 ( $t=0$ ), then the price change rates at years 1,2,...,t are  $j_1, j_2, \dots, j_t$ , respectively. Let  $A_t$  be the cost in year  $t$  expressed in base-year dollars and  $A_t'$  be the cost in year  $t$  expressed in then-current dollars. Then:

$$(5.16) \quad A_t' = A_t (1 + j_1)(1 + j_2) \dots (1 + j_{t-1})(1 + j_t) = A_t \left( \frac{I_t}{I_0} \right)$$

Conversely

$$(5.17) \quad A_t = A_t' (1 + j_t)^{-1} (1 + j_{t-1})^{-1} \dots (1 + j_2)^{-1} (1 + j_1)^{-1} = A_t' \left( \frac{I_0}{I_t} \right)$$

If the prices of certain key items affecting the estimates of future benefits and costs are expected to escalate faster than the general price levels, it may become necessary to consider the differential price changes over and above the general inflation rate. For example, during the period between 1973 through 1979, it was customary to assume that fuel costs would escalate faster than the general price levels. With hindsight in 1983, the assumption for estimating costs over many years would have been different. Because of the uncertainty in the future, the use of differential inflation rates for special items should be judicious.

Future forecasts of costs will be uncertain: the actual expenses may be much lower or much higher than those forecasted. This uncertainty arises from technological changes, changes in relative prices, inaccurate forecasts of underlying socioeconomic conditions, analytical errors, and other factors. For the purpose of forecasting, it is often sufficient to project the trend of future prices by using a constant rate  $j$  for price changes in each year over a period of  $t$  years, then

$$(5.18) \quad A_t' = A_t (1 + j)^t$$

and

$$(5.19) \quad A_t = A_t' (1 + j)^{-t}$$

Estimation of the future rate increase  $j$  is not at all straightforward. A simple expedient is to assume that future inflation will continue at the rate of the previous period:

$$(5.20)$$

$$j = j_{t-1}$$

A longer term perspective might use the average increase over a horizon of n past periods:

$$(5.21) \quad j = \sum_{i=1}^n \frac{j_{t-i}}{n}$$

More sophisticated forecasting models to predict future cost increases include corrections for items such as economic cycles and technology changes.

#### Example 5-12: Changes in highway and building costs

Figure 5-9 shows the change of standard highway costs from 1992 to 2002, and Table 5-10 shows the change of residential building costs from 1970 to 1990. In each case, the rate of cost increase was substantially above the rate of inflation in the decade of the 1970s.. Indeed, the real cost increase between 1970 and 1980 was in excess of three percent per year in both cases. However, these data also show some cause for optimism. For the case of the standard highway, real cost *decreases* took place in the period from 1970 to 1990. Unfortunately, comparable indices of outputs are not being compiled on a nationwide basis for other types of construction.



**Figure 5-9** Producer Prices of Highway and Street Construction (Producer Price Index: Highways and Streets-monthly data).

**TABLE 5-10** Comparison of Residential Building Costs, 1970-1990

year	Standard residence cost (1972=100)	Price deflator (1972=100)	Standard residence real cost (1972=100)	Percentage change per year
1970	77	92	74	
1980	203	179	99	+3.4%
1990	287	247	116	+1.7%

Source: *Statistical Abstract of the United States*. GNP deflator is used for the price deflator index.

[Back to top](#)

## 5.9 Applications of Cost Indices to Estimating

In the screening estimate of a new facility, a single parameter is often used to describe a cost function. For example, the cost of a power plant is a function of electricity generating capacity expressed in megawatts, or the cost of a sewage treatment plant as a function of waste flow expressed in million gallons per day.

The general conditions for the application of the single parameter cost function for screening estimates are:

1. Exclude special local conditions in historical data
2. Determine new facility cost on basis of specified size or capacity (using the methods described in Sections 5.3 to 5.6)
3. Adjust for inflation index
4. Adjust for local index of construction costs
5. Adjust for different regulatory constraints
6. Adjust for local factors for the new facility

Some of these adjustments may be done using compiled indices, whereas others may require field investigation and considerable professional judgment to reflect differences between a given project and standard projects performed in the past.

### Example 5-13: Screening estimate for a refinery

The total construction cost of a refinery with a production capacity of 200,000 bbl/day in Gary, Indiana, completed in 2001 was \$100 million. It is proposed that a similar refinery with a production capacity of 300,000 bbl/day be built in Los Angeles, California, for completion in 2003. For the additional information given below, make an order of magnitude estimate of the cost of the proposed plant.

1. In the total construction cost for the Gary, Indiana, plant, there was an item of \$5 million for site preparation which is not typical for other plants.
2. The variation of sizes of the refineries can be approximated by the exponential rule, Equation (5.4), with  $m = 0.6$ .
3. The inflation rate is expected to be 8% per year from 1999 to 2003.
4. The location index was 0.92 for Gary, Indiana and 1.14 for Los Angeles in 1999. These indices are deemed to be appropriate for adjusting the costs between these two cities.
5. New air pollution equipment for the LA plant costs \$7 million in 2003 dollars (not required in the Gary plant).
6. The contingency cost due to inclement weather delay will be reduced by the amount of 1% of total construction cost because of the favorable climate in LA (compared to Gary).

On the basis of the above conditions, the estimate for the new project may be obtained as follows:

1. Typical cost excluding special item at Gary, IN is

$$\$100 \text{ million} - \$5 \text{ million} = \$95 \text{ million}$$

2. Adjustment for capacity based on the exponential law yields

$$(\$95)(300,000/200,000)^{0.6} = (95)(1.5)^{0.6} = \$121.2 \text{ million}$$

3. Adjustment for inflation leads to the cost in 2003 dollars as

$$(\$121.2)(1.08)^4 = \$164.6 \text{ million}$$

4. Adjustment for location index gives

$$(\$164.6)(1.14/0.92) = \$204.6 \text{ million}$$

5. Adjustment for new pollution equipment at the LA plant gives

$$\$204.6 + \$7 = \$211.6 \text{ million}$$

## 6. Reduction in contingency cost yields

$$(\$211.6)(1-0.01) = \$209.5 \text{ million}$$

Since there is no adjustment for the cost of construction financing, the order of magnitude estimate for the new project is \$209.5 million.

**Example 5-14: Conceptual estimate for a chemical processing plant**

In making a preliminary estimate of a chemical processing plant, several major types of equipment are the most significant parameters in affecting the installation cost. The cost of piping and other ancillary items for each type of equipment can often be expressed as a percentage of that type of equipment for a given capacity. The standard costs for the major equipment types for two plants with different daily production capacities are as shown in Table 5-11. It has been established that the installation cost of all equipment for a plant with daily production capacity between 100,000 bbl and 400,000 bbl can best be estimated by using linear interpolation of the standard data.

**TABLE 5-11** Cost Data for Equipment and Ancillary Items

Equipment type	Equipment Cost (\$1000)		Cost of ancillary items as % of equipment cost (\$1000)	
	100,000 bbl	400,000 bbl	100,000 bbl	400,000 bbl
Furnace	3,000	10,000	40%	30%
Tower	2,000	6,000	45%	35%
Drum	1,500	5,000	50%	40%
Pump, etc.	1,000	4,000	60%	50%

A new chemical processing plant with a daily production capacity of 200,000 bbl is to be constructed in Memphis, TN in four years. Determine the total preliminary cost estimate of the plant including the building and the equipment on the following basis:

1. The installation cost for equipment was based on linear interpolation from Table 5-11, and adjusted for inflation for the intervening four years. We expect inflation in the four years to be similar to the period 1990-1994 and we will use the GNP Deflator index.
2. The location index for equipment installation is 0.95 for Memphis, TN, in comparison with the standard cost.
3. An additional cost of \$500,000 was required for the local conditions in Memphis, TN.

The solution of this problem can be carried out according to the steps as outlined in the problem statement:

1. The costs of the equipment and ancillary items for a plant with a capacity of 200,000 bbl can be estimated by linear interpolation of the data in Table 5-11 and the results are shown in Table 5-12.

**TABLE 5-12** Results of Linear Interpolation for an Estimation Example

Equipment type	Equipment Cost (in \$1,000)	Percentage for ancillary items
Furnace	$\$3,000 + (1/3)(\$10,000 - \$3,000) = \$5,333$	$40\% - (1/3)(40\% - 30\%) = 37\%$
Tower	$\$2,000 + (1/3)(\$6,000 - \$2,000) = \$3,333$	$45\% - (1/3)(45\% - 35\%) = 42\%$
Drum	$\$1,500 + (1/3)(\$5,000 - \$1,500) = \$2,667$	$50\% - (1/3)(50\% - 40\%) = 47\%$
Pumps, etc.	$\$1,000 + (1/3)(\$4,000 - \$1,000) = \$2,000$	$60\% - (1/3)(60\% - 50\%) = 57\%$

Hence, the total project cost in thousands of current dollars is given by Equation (5.8) as:

$$(\$5,333)(1.37) + (\$3,333)(1.42) + (\$2,667)(1.47) + (\$2,000)(1.57) = \\ = \$2,307 + \$4,733 + \$3,920 + \$3,140 = \$19,100$$

2. The corresponding cost in thousands of four year in the future dollars using Equation (5.16) and Table 5-9 is:

$$(\$19,100)(105/94) = \$21,335$$

3. The total cost of the project after adjustment for location is

$$(0.95)(\$21,335,000) + \$500,000 \approx \$20,800,000$$

[Back to top](#)

## 5.10 Estimate Based on Engineer's List of Quantities

The engineer's estimate is based on a list of items and the associated quantities from which the total construction cost is derived. This same list is also made available to the bidders if unit prices of the items on the list are also solicited from the bidders. Thus, the itemized costs submitted by the winning contractor may be used as the starting point for budget control.

In general, the progress payments to the contractor are based on the units of work completed and the corresponding unit prices of the work items on the list. Hence, the estimate based on the engineers' list of quantities for various work items essentially defines the level of detail to which subsequent measures of progress for the project will be made.

### Example 5-15: Bid estimate based on engineer's list of quantities

Using the unit prices in the bid of contractor 1 for the quantities specified by the engineer in Table 5-2 (Example 5-3), we can compute the total bid price of contractor 1 for the roadway project. The itemized costs for various work items as well as the total bid price are shown in Table 5-13.

**TABLE 5-13:** Bid Price of Contractor 1 in a Highway Project

Items	Unit	Quantity	Unit price	Item cost
Mobilization	ls	1	115,000	115,000
Removal, berm	lf	8,020	1.00	8,020
Finish subgrade	sy	1,207,500	0.50	603,750
Surface ditches	lf	525	2.00	1,050
Excavation structures	cy	7,000	3.00	21,000
Base course, untreated, 3/4"	ton	362,200	4.50	1,629,900
Lean concrete, 4" thick	sy	820,310	3.10	2,542,961
PCC, pavement, 10" thick	sy	76,010	10.90	7,695,509
Concrete, ci AA (AE)	ls	1	200,000	200,000
Small structure	cy	50	500	25,000
Barrier, precast	lf	7,920	15.00	118,800
Flatwork, 4" thick	sy	7,410	10.00	74,100
10" thick	sy	4,241	20.00	84,820
Slope protection	sy	2,104	25.00	52,600
Metal, end section, 15"	ea	39	100	3,900
18"	ea	3	150	450
Post, right-of-way, modification	lf	4,700	3.00	14,100
Salvage and relay pipe	lf	1,680	5.00	8,400
Loose riprap	cy	32	40.00	1,280
Braced posts	ea	54	100	5,400
Delineators, type I	lb	1,330	12.00	15,960
type II	ea	140	15.00	2,100
Constructive signs fixed	sf	52,600	0.10	5,260
Barricades, type III	lf	29,500	0.20	5,900
Warning lights	day	6,300	0.10	630
Pavement marking, epoxy material				

Black	gal	475	90.00	42,750
Yellow	gal	740	90.00	66,600
White	gal	985	90.00	88,650
Plowable, one-way white	ea	342	50.00	17,100
Topsoil, contractor furnished	cy	260	10.00	2,600
Seedling, method A	acr	103	150	15,450
Excelsior blanket	sy	500	2.00	1,000
Corrugated, metal pipe, 18"	lf	580	20.00	11,600
Polyethylene pipe, 12"	lf	2,250	15.00	33,750
Catch basin grate and frame	ea	35	350	12,250
Equal opportunity training	hr	18,000	0.80	14,400
Granular backfill borrow	cy	274	10.00	2,740
Drill caisson, 2'x6"	lf	722	100	72,200
Flagging	hr	20,000	8.25	165,000
Prestressed concrete member				
type IV, 141'x4"	ea	7	12,000	84,000
132'x4"	ea	6	11,000	66,000
Reinforced steel	lb	6,300	0.60	3,780
Epoxy coated	lb	122,241	0.55	67,232.55
Structural steel	ls	1	5,000	5,000
Sign, covering	sf	16	10.00	160
type C-2 wood post	sf	98	15.00	1,470
24"	ea	3	100	300
30"	ea	2	100	200
48"	ea	11	200	2,200
Auxiliary	sf	61	15.00	915
Steel post, 48'x60"	ea	11	500	5,500
type 3, wood post	sf	669	15.00	10,035
24"	ea	23	100	2,300
30"	ea	1	100	100
36"	ea	12	150	1,800
42'x60"	ea	8	150	1,200
48"	ea	7	200	1,400
Auxiliary	sf	135	15.00	2,025
Steel post	sf	1,610	40.00	64,400
12'x36"	ea	28	100	2,800
Foundation, concrete	ea	60	300	18,000
Barricade, 48'x42"	ea	40	100	4,000
Wood post, road closed	lf	100	30.00	3,000
<b>Total</b>				<b>\$14,129,797.55</b>

[Back to top](#)

## 5.11 Allocation of Construction Costs Over Time

Since construction costs are incurred over the entire construction phase of a project, it is often necessary to determine the



amounts to be spent in various periods to derive the cash flow profile, especially for large projects with long durations. Consequently, it is important to examine the percentage of work expected to be completed at various time periods to which the costs would be charged. More accurate estimates may be accomplished once the project is scheduled as described in Chapter 10, but some rough estimate of the cash flow may be required prior to this time.

Consider the basic problem in determining the percentage of work completed during construction. One common method of estimating percentage of completion is based on the amount of money spent relative to the total amount budgeted for the entire project. This method has the obvious drawback in assuming that the amount of money spent has been used efficiently for production. A more reliable method is based on the concept of *value of work completed* which is defined as the product of the budgeted labor hours per unit of production and the actual number of production units completed, and is expressed in budgeted labor hours for the work completed. Then, the percentage of completion at any stage is the ratio of the value of work completed to date and the value of work to be completed for the entire project. Regardless of the method of measurement, it is informative to understand the trend of work progress during construction for evaluation and control.

In general, the work on a construction project progresses gradually from the time of mobilization until it reaches a plateau; then the work slows down gradually and finally stops at the time of completion. The rate of work done during various time periods (expressed in the percentage of project cost per unit time) is shown schematically in Figure 5-10 in which ten time periods have been assumed. The solid line A represents the case in which the rate of work is zero at time  $t = 0$  and increases linearly to 12.5% of project cost at  $t = 2$ , while the rate begins to decrease from 12.5% at  $t = 8$  to 0% at  $t = 10$ . The dotted line B represents the case of rapid mobilization by reaching 12.5% of project cost at  $t = 1$  while beginning to decrease from 12.5% at  $t = 7$  to 0% at  $t = 10$ . The dash line C represents the case of slow mobilization by reaching 12.5% of project cost at  $t = 3$  while beginning to decrease from 12.5% at  $t = 9$  to 0% at  $t = 10$ .

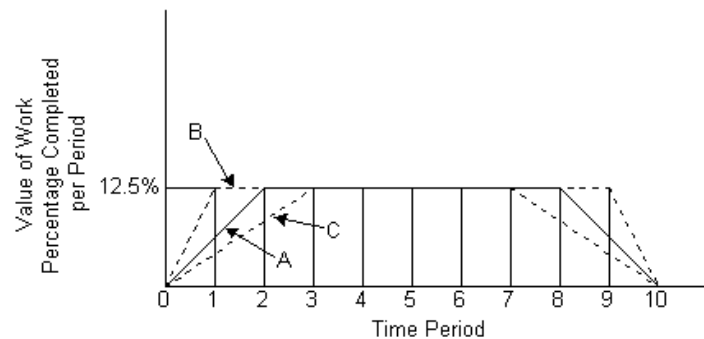

**Figure 5-10:** Rate of Work Progress over Project Time

The value of work completed at a given time (expressed as a cumulative percentage of project cost) is shown schematically in Figure 5-11. In each case (A, B or C), the value of work completed can be represented by an "S-shaped" curve. The effects of rapid mobilization and slow mobilization are indicated by the positions of curves B and C relative to curve A, respectively.

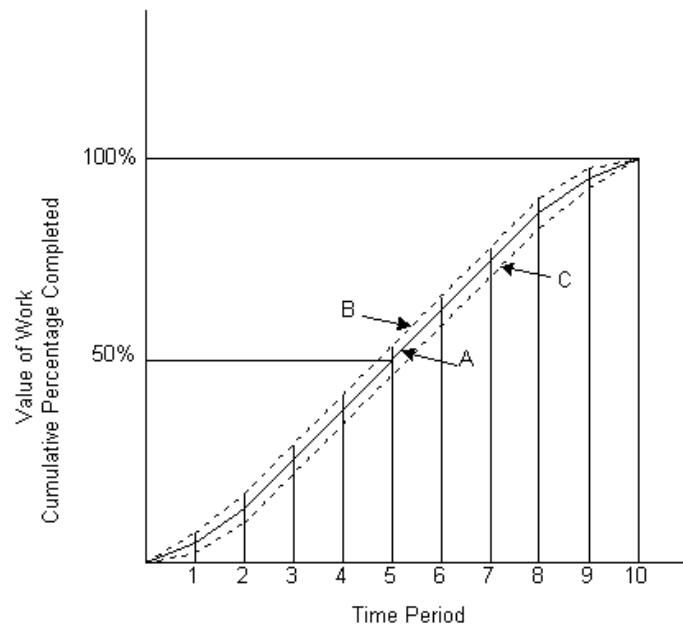

**Figure 5-11:** Value of Work Completed over Project Time

While the curves shown in Figures 5-10 and 5-11 represent highly idealized cases, they do suggest the latitude for adjusting the schedules for various activities in a project. While the rate of work progress may be changed quite drastically within a single period, such as the change from rapid mobilization to a slow mobilization in periods 1, 2 and 3 in Figure 5-10, the effect on the value of work completed over time will diminish in significance as indicated by the cumulative percentages for later periods in Figure 5-11. Thus, adjustment of the scheduling of some activities may improve the utilization of labor, material and equipment, and any delay caused by such adjustments for individual activities is not likely to cause problems for the eventual progress toward the completion of a project.

In addition to the speed of resource mobilization, another important consideration is the overall duration of a project and the amount of resources applied. Various strategies may be applied to shorten the overall duration of a project such as overlapping design and construction activities (as described in Chapter 2) or increasing the peak amounts of labor and equipment working on a site. However, spatial, managerial and technical factors will typically place a minimum limit on the project duration or cause costs to escalate with shorter durations.

#### Example 5-16: Calculation of Value of Work Completed

From the area of work progress in Figure 5-10, the value of work completed at any point in Figure 5-11 can be derived by noting the area under the curve up to that point in Figure 5-10. The result for  $t = 0$  through  $t = 10$  is shown in Table 5-14 and plotted in Figure 5-11.

**TABLE 5-14** Calculation of Value of Work Completed

Time	Case A	Case B	Case C
0	0	0	0
1	3.1%	6.2%	2.1%
2	12.5	18.7	8.3
3	25.0	31.2	18.8
4	37.5	43.7	31.3
5	50.0	56.2	43.8
6	62.5	68.7	56.3

7	75.0	81.2	68.8
8	87.5	91.7	81.9
9	96.9	97.9	93.8
10	100.0	100.0	100.0

---

[Back to top](#)

## 5.12 Computer Aided Cost Estimation

Numerous computer aided cost estimation software systems are now available. These range in sophistication from simple spreadsheet calculation software to integrated systems involving design and price negotiation over the Internet. While this software involves costs for purchase, maintenance, training and computer hardware, some significant efficiencies often result. In particular, cost estimates may be prepared more rapidly and with less effort.

Some of the common features of computer aided cost estimation software include:

- Databases for unit cost items such as worker wage rates, equipment rental or material prices. These databases can be used for any cost estimate required. If these rates change, cost estimates can be rapidly re-computed after the databases are updated.
- Databases of expected productivity for different components types, equipment and construction processes.
- Import utilities from computer aided design software for automatic quantity-take-off of components. Alternatively, special user interfaces may exist to enter geometric descriptions of components to allow automatic quantity-take-off.
- Export utilities to send estimates to cost control and scheduling software. This is very helpful to begin the management of costs during construction.
- Version control to allow simulation of different construction processes or design changes for the purpose of tracking changes in expected costs.
- Provisions for manual review, over-ride and editing of any cost element resulting from the cost estimation system
- Flexible reporting formats, including provisions for electronic reporting rather than simply printing cost estimates on paper.
- Archives of past projects to allow rapid cost-estimate updating or modification for similar designs.

A typical process for developing a cost estimate using one of these systems would include:

1. If a similar design has already been estimated or exists in the company archive, the old project information is retrieved.
2. A cost engineer modifies, add or deletes components in the project information set. If a similar project exists, many of the components may have few or no updates, thereby saving time.
3. A cost estimate is calculated using the unit cost method of estimation. Productivities and unit prices are retrieved from the system databases. Thus, the latest price information is used for the cost estimate.
4. The cost estimation is summarized and reviewed for any errors.

[Back to top](#)

## 5.13 Estimation of Operating Costs

In order to analyze the life cycle costs of a proposed facility, it is necessary to estimate the operation and maintenance costs over time after the start up of the facility. The stream of operating costs over the life of the facility depends upon subsequent maintenance policies and facility use. In particular, the magnitude of routine maintenance costs will be reduced if the facility undergoes periodic repairs and rehabilitation at periodic intervals.

Since the tradeoff between the capital cost and the operating cost is an essential part of the economic evaluation of a facility, the operating cost is viewed not as a separate entity, but as a part of the larger parcel of life cycle cost at the planning and design stage. The techniques of estimating life cycle costs are similar to those used for estimating capital costs, including empirical cost functions and the unit cost method of estimating the labor, material and equipment costs. However, it is the interaction of the operating and capital costs which deserve special attention.

As suggested earlier in the discussion of the exponential rule for estimating, the value of the cost exponent may influence the decision whether extra capacity should be built to accommodate future growth. Similarly, the economy of scale may also influence the decision on rehabilitation at a given time. As the rehabilitation work becomes extensive, it becomes a capital

project with all the implications of its own life cycle. Hence, the cost estimation of a rehabilitation project may also involve capital and operating costs.

While deferring the discussion of the economic evaluation of constructed facilities to Chapter 6, it is sufficient to point out that the stream of operating costs over time represents a series of costs at different time periods which have different values with respect to the present. Consequently, the cost data at different time periods must be converted to a common base line if meaningful comparison is desired.

#### Example 5-17: Maintenance cost on a roadway [6]

Maintenance costs for constructed roadways tend to increase with both age and use of the facility. As an example, the following empirical model was estimated for maintenance expenditures on sections of the Ohio Turnpike:

$$C = 596 + 0.0019 V + 21.7 A$$

where  $C$  is the annual cost of routine maintenance per lane-mile (in 1967 dollars),  $V$  is the volume of traffic on the roadway (measured in equivalent standard axle loads, ESAL, so that a heavy truck is represented as equivalent to many automobiles), and  $A$  is the age of the pavement in years since the last resurfacing. According to this model, routine maintenance costs will increase each year as the pavement service deteriorates. In addition, maintenance costs increase with additional pavement stress due to increased traffic or to heavier axle loads, as reflected in the variable  $V$ .

For example, for  $V = 500,300$  ESAL and  $A = 5$  years, the annual cost of routine maintenance per lane-mile is estimated to be:

$$\begin{aligned} C &= 596 + (0.0019)(500,300) + (21.7)(5) \\ &= 596 + 950.5 + 108.5 = 1,655 \text{ (in 1967 dollars)} \end{aligned}$$

#### Example 5-18: Time stream of costs over the life of a roadway [7]

The time stream of costs over the life of a roadway depends upon the intervals at which rehabilitation is carried out. If the rehabilitation strategy and the traffic are known, the time stream of costs can be estimated.

Using a life cycle model which predicts the economic life of highway pavement on the basis of the effects of traffic and other factors, an optimal schedule for rehabilitation can be developed. For example, a time stream of costs and resurfacing projects for one pavement section is shown in Figure 5-11. As described in the previous example, the routine maintenance costs increase as the pavement ages, but decline after each new resurfacing. As the pavement continues to age, resurfacing becomes more frequent until the roadway is completely reconstructed at the end of 35 years.

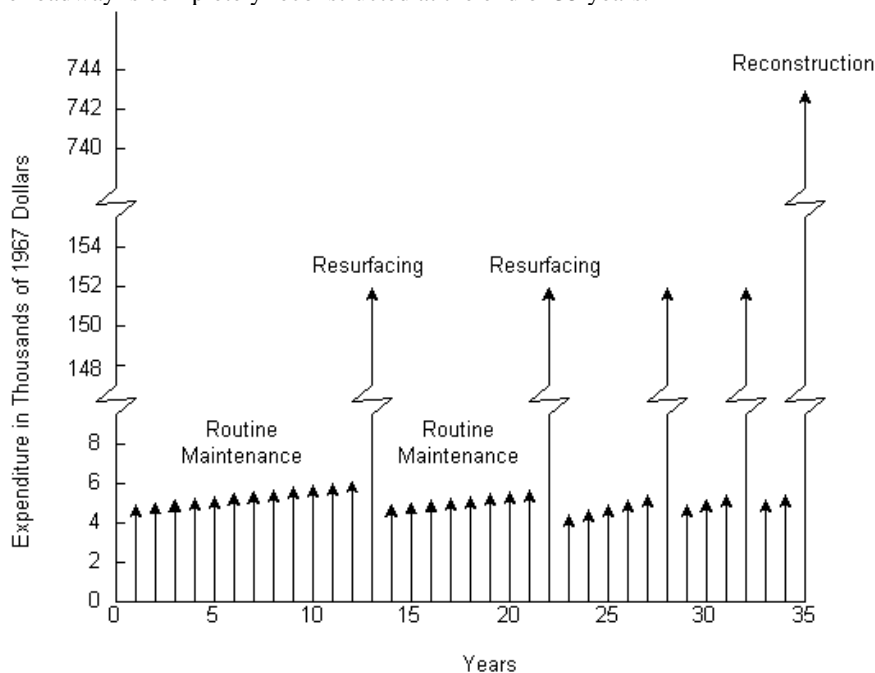

Figure 5-11: Time Stream of Costs over the Life of a Highway Pavement

[Back to top](#)

## 5.14 References

1. Ahuja, H.N. and W.J. Campbell, *Estimating: From Concept to Completion*, Prentice-Hall, Inc., Englewood Cliffs, NJ, 1987.
2. Clark, F.D., and A.B. Lorenzoni, *Applied Cost Engineering*, Marcel Dekker, Inc., New York, 1978.
3. Clark, J.E., *Structural Concrete Cost Estimating*, McGraw-Hill, Inc., New York, 1983.
4. Diekmann, J.R., "Probabilistic Estimating: Mathematics and Applications," *ASCE Journal of Construction Engineering and Management*, Vol. 109, 1983, pp. 297-308.
5. Humphreys, K.K. (ed.) *Project and Cost Engineers' Handbook* (sponsored by American Association of Cost Engineers), 2nd Ed., Marcel Dekker, Inc., New York, 1984.
6. Maevis, A.C., "Construction Cost Control by the Owners," *ASCE Journal of the Construction Division*, Vol. 106, 1980, pp. 435-446.
7. Wohl, M. and C. Hendrickson, *Transportation Investment and Pricing Principles*, John Wiley & Sons, New York, 1984.

[Back to top](#)

## 5.15 Problems

1. Suppose that the grouting method described in Example 5-2 is used to provide a grouting seal beneath another landfill of 12 acres. The grout line is expected to be between 4.5 and 5.5 feet thickness. The voids in the soil layer are between 25% to 35%. Using the same unit cost data (in 1978 dollars), find the range of costs in a screening estimate for the grouting project.
2. To avoid submerging part of U.S. Route 40 south and east of Salt Lake City due to the construction of the Jardinal Dam and Reservoir, 22 miles of highway were relocated to the west around the site of the future reservoir. Three separate contracts were let, including one covering 10 miles of the work which had an engineer's estimate of \$34,095,545. The bids were submitted on July 21, 1987 and the completion date of the project under the contract was August 15, 1989. (See *ENR*, October 8, 1987, p. 34). The three lowest bids were:
 

1) W.W. Clyde & Co., Springville, Utah	\$21,384,919
2) Sletten Construction company, Great Falls, Montana	\$26,701,018
3) Gilbert Western Corporation, Salt Lake city, Utah	\$30,896,203

Find the percentage of each of these bidders below the engineer's cost estimate.

3. In making a screening estimate of an industrial plant for the production of batteries, an empirical formula based on data of a similar buildings completed before 1987 was proposed:

$$C = (16,000)(Q + 50,000)^{1/2}$$

where Q is the daily production capacity of batteries and C is the cost of the building in 1987 dollars. If a similar plant is planned for a daily production capacity of 200,000 batteries, find the screening estimate of the building in 1987 dollars.

4. For the cost factor  $K = \$46,000$  (in 1968 dollars) and  $m = 0.67$  for an aerated lagoon basin of a water treatment plant in Table 5-4 (Example 5-6), find the estimated cost of a proposed new plant with a similar treatment process having a capacity of 480 million gallons (in 1968 dollars). If another new plant was estimated to cost \$160,000 by using the same exponential rule, what would be the proposed capacity of that plant?
5. Using the cost data in Figure 5-5 (Example 5-11), find the total cost including overhead and profit of excavating 90,000 cu.yd. of bulk material using a backhoe of 1.5 cu.yd. capacity for a detailed estimate. Assume that the excavated material will be loaded onto trucks for disposal.
6. The basic costs (labor, material and equipment) for various elements of a construction project are given as follows:

Excavation	\$240,000
Subgrade	\$100,000
Base course	\$420,000
Concrete pavement	<u>\$640,000</u>
Total	\$1,400,000

Assuming that field supervision cost is 10% of the basic cost, and the general office overhead is 5% of the direct costs

(sum of the basic costs and field supervision cost), find the prorated field supervision costs, general office overhead costs and total costs for the various elements of the project.

7. In making a preliminary estimate of a chemical processing plant, several major types of equipment are the most significant components in affecting the installation cost. The cost of piping and other ancillary items for each type of equipment can often be expressed as a percentage of that type of equipment for a given capacity. The standard costs for the major equipment types for two plants with different daily production capacities are as shown in Table 5-15. It has been established that the installation cost of all equipment for a plant with daily production capacity between 150,000 bbl and 600,000 bbl can best be estimated by using linear interpolation of the standard data. A new chemical processing plant with a daily production capacity of 400,000 bbl is being planned. Assuming that all other factors remain the same, estimate the cost of the new plant.

**Table 5-15**

Equipment type	Equipment cost (\$1,000)		Factor for ancillary items	
	150,000 bbl	600,000 bbl	150,000 bbl	600,000 bbl
Furnace	\$3,000	\$10,000	0.32	0.24
Tower	2,000	6,000	0.42	0.36
Drum	1,500	5,000	0.42	0.32
Pumps, etc.	1,000	4,000	0.54	0.42

8. The total construction cost of a refinery with a production capacity of 100,000 bbl/day in Caracas, Venezuela, completed in 1977 was \$40 million. It was proposed that a similar refinery with a production capacity of 160,000 bbl/day be built in New Orleans, LA for completion in 1980. For the additional information given below, make a screening estimate of the cost of the proposed plant.
- In the total construction cost for the Caracas, Venezuela plant, there was an item of \$2 million for site preparation and travel which is not typical for similar plants.
  - The variation of sizes of the refineries can be approximated by the exponential law with  $m = 0.6$ .
  - The inflation rate in U.S. dollars was approximately 9% per year from 1977 to 1980.
  - An adjustment factor of 1.40 was suggested for the project to account for the increase of labor cost from Caracas, Venezuela to New Orleans, LA.
  - New air pollution equipment for the New Orleans, LA plant cost \$4 million in 1980 dollars (not required for the Caracas plant).
  - The site condition at New Orleans required special piling foundation which cost \$2 million in 1980 dollars.
9. The total cost of a sewage treatment plant with a capacity of 50 million gallons per day completed 1981 for a new town in Colorado was \$4.5 million. It was proposed that a similar treatment plant with a capacity of 80 million gallons per day be built in another town in New Jersey for completion in 1985. For additional information given below, make a screening estimate of the cost of the proposed plant.
- In the total construction cost in Colorado, an item of \$300,000 for site preparation is not typical for similar plants.
  - The variation of sizes for this type of treatment plants can be approximated by the exponential law with  $m = 0.5$ .
  - The inflation rate was approximately 5% per year from 1981 to 1985.
  - The locational indices of Colorado and New Jersey areas are 0.95 and 1.10, respectively, against the national average of 1.00.
  - The installation of a special equipment to satisfy the new environmental standard cost an extra \$200,000 in 1985 dollar for the New Jersey plant.
  - The site condition in New Jersey required special foundation which cost \$500,00 in 1985 dollars.
10. Using the *ENR* building cost index, estimate the 1985 cost of the grouting seal on a landfill described in Example 5-2, including the most likely estimate and the range of possible cost.
11. Using the unit prices in the bid of contractor 2 for the quantities specified by the engineer in Table 5-2 (Example 5-3), compute the total bid price of contractor 2 for the roadway project including the expenditure on each item of work.
12. The rate of work progress in percent of completion per period of a construction project is shown in Figure 5-13 in which 13 time periods have been assumed. The cases A, B and C represent the normal mobilization time, rapid mobilization and slow mobilization for the project, respectively. Calculate the value of work completed in cumulative percentage for periods 1 through 13 for each of the cases A, B and C. Also plot the volume of work completed versus time for these cases.

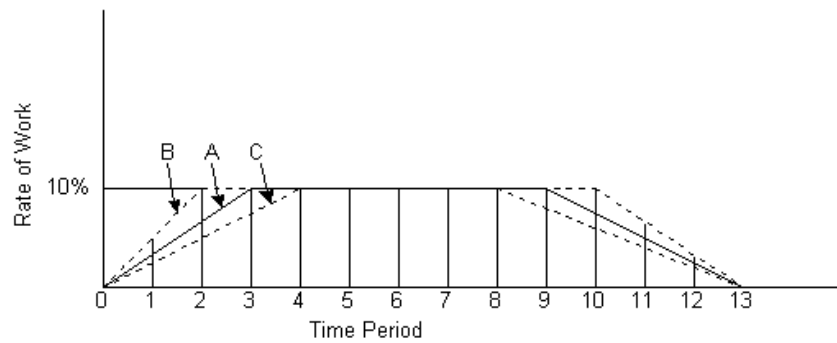

Figure 5-13

13. The rate of work progress in percent of completion per period of a construction project is shown in Figure 5-14 in which 10 time periods have been assumed. The cases A, B and C represent the rapid mobilization time, normal mobilization and slow mobilization for the project, respectively. Calculate the value of work completed in cumulative percentage for periods 1 through 10 for each of the cases A, B and C. Also plot the volume of work completed versus time for these cases.

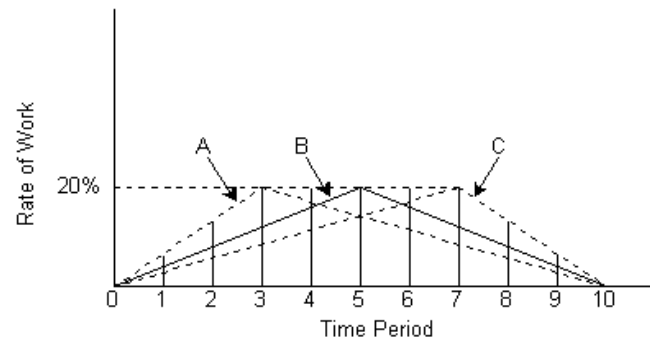

Figure 5-14

14. Suppose that the empirical model for estimating annual cost of routine maintenance in Example 5-17 is applicable to sections of the Pennsylvania Turnpike in 1985 if the *ENR* building cost index is applied to inflate the 1967 dollars. Estimate the annual cost of maintenance per lane-mile of the turnpike for which the traffic volume on the roadway is 750,000 ESAL and the age of the pavement is 4 years in 1985.
15. The initial construction cost for a electric power line is known to be a function of the cross-sectional area  $A$  (in  $\text{cm}^2$ ) and the length  $L$  (in kilometers). Let  $C_1$  be the unit cost of construction (in dollars per  $\text{cm}^3$ ). Then, the initial construction cost  $P$  (in dollars) is given by

$$P = C_1 A L (10^5)$$

The annual operating cost of the power line is assumed to be measured by the power loss. The power loss  $S$  (in kwh) is known to be

$$S = \frac{J^2 R}{10^3} \left[ \frac{L(10^5)}{A} \right] = \frac{J^2 R L}{A} (10^2)$$

where  $J$  is the electric current in amperes,  $R$  is the resistivity in ohm-centimeters. Let  $C_2$  be the unit operating cost (in dollars per kwh). Then, the annual operating cost  $U$  (in dollars) is given by

$$U = C_2 \frac{J^2 RL}{A} (10^2)$$

Suppose that the power line is expected to last  $n$  years and the life cycle cost  $T$  of the power line is equal to:

$$T = P + UK$$

where  $K$  is a discount factor depending on the useful life cycle  $n$  and the discount rate  $i$  (to be explained in Chapter 6). In designing the power line, all quantities are assumed to be known except  $A$  which is to be determined. If the owner wants to minimize the life cycle cost, find the best cross-sectional area  $A$  in terms of the known quantities.

[Back to top](#)

## 5.16 Footnotes

1. This example was adapted with permission from a paper, "Forecasting Industry Resources," presented by A.R. Crosby at the Institution of Chemical Engineers in London, November 4, 1981. ([Back](#))
2. This example is adapted from a cost estimate in A.L. Tolman, A.P. Ballestero, W.W. Beck and G.H. Emrich, *Guidance Manual for Minimizing Pollution from Waste Disposal Sites*, Municipal Environmental Research Laboratory, U.S. Environmental Protection Agency, Cincinnati, Ohio, 1978. ([Back](#))
3. See "Utah Interstate Forges On," *ENR*, July 2, 1987, p. 39. ([Back](#))
4. This and the next example have been adapted from P.M. Berthouex, "Evaluating Economy of Scale," *Journal of the Water Pollution Control Federation*, Vol. 44, No. 11, November 1972, pp. 2111-2118. ([Back](#))
5. See H.T. Johnson and R.S. Kaplan, *Relevance Lost: The Rise and Fall of Management Accounting*, Harvard Business School Press, Boston, MA 1987, p. 185. ([Back](#))
6. This example is adapted from McNeil, S. and C. Hendrickson, "A Statistical Model of Pavement Maintenance Expenditure," *Transportation Research Record* No. 846, 1982, pp. 71-76. ([Back](#))
7. This example is adapted from S. McNeil, *Three Statistical Models of Road Management Based on Turnpike Data*, M.S. Thesis, Carnegie-Mellon University, Pittsburgh, PA, 1981. ([Back](#))

[Previous Chapter](#) | [Table of Contents](#) | [Next Chapter](#)



<a href="#">Go Up to Table of Contents</a>	
<a href="#">Go To Chapter 5 (Cost Estimation)</a>	<a href="#">Go To Chapter 7 (Financing of Constructed Facilities)</a>
<a href="#">Economic Evaluation of Facility Investments</a> <a href="#">Project Life Cycle and Economic Feasibility</a> <a href="#">Basic Concepts of Economic Evaluation</a> <a href="#">Costs and Benefits of a Constructed Facility</a> <a href="#">Interest Rates and the Costs of Capital</a> <a href="#">Investment Profit Measures</a> <a href="#">Methods of Economic Evaluation</a> <a href="#">Depreciation and Tax Effects</a> <a href="#">Price Level Changes: Inflation and Deflation</a> <a href="#">Uncertainty and Risk</a> <a href="#">Effects of Financing on Project Selection</a> <a href="#">Combined Effects of Operating and Financing Cash Flows</a> <a href="#">Public versus Private Ownership of Facilities</a> <a href="#">Economic Evaluation of Different Forms of Ownership</a> <a href="#">References</a> <a href="#">Problems</a>	

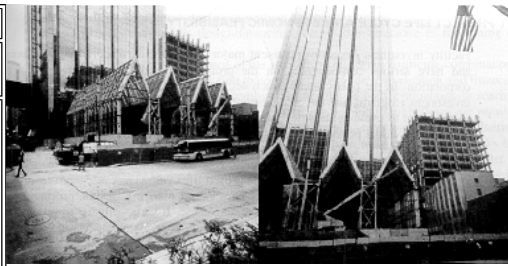

[http://pmbook.ce.cmu.edu/06\\_Economic\\_Evaluation\\_of\\_Facility\\_Investments.html](http://pmbook.ce.cmu.edu/06_Economic_Evaluation_of_Facility_Investments.html)

## 6. Economic Evaluation of Facility Investments

### 6.1 Project Life Cycle and Economic Feasibility

Facility investment decisions represent major commitments of corporate resources and have serious consequences on the profitability and financial stability of a corporation. In the public sector, such decisions also affect the viability of facility investment programs and the credibility of the agency in charge of the programs. It is important to evaluate facilities rationally with regard to both the economic feasibility of individual projects and the relative net benefits of alternative and mutually exclusive projects.

This chapter will present an overview of the decision process for economic evaluation of facilities with regard to the project life cycle. The cycle begins with the initial conception of the project and continues through planning, design, procurement, construction, start-up, operation and maintenance. It ends with the disposal of a facility when it is no longer productive or useful. Four major aspects of economic evaluation will be examined:

1. The basic concepts of facility investment evaluation, including time preference for consumption, opportunity cost, minimum attractive rate of return, cash flows over the planning horizon and profit measures.
2. Methods of economic evaluation, including the net present value method, the equivalent uniform annual value method, the benefit-cost ratio method, and the internal rate of return method.
3. Factors affecting cash flows, including depreciation and tax effects, price level changes, and treatment of risk and uncertainty.
4. Effects of different methods of financing on the selection of projects, including types of financing and risk, public policies on regulation and subsidies, the effects of project financial planning, and the interaction between operational and financial planning.

In setting out the engineering economic analysis methods for facility investments, it is important to emphasize that not all facility impacts can be easily estimated in dollar amounts. For example, firms may choose to minimize environmental impacts of construction or facilities in pursuit of a "triple bottom line:" economic, environmental and social. By reducing environmental impacts, the firm may reap benefits from an improved reputation and a more satisfied workforce. Nevertheless, a rigorous economic evaluation can aid in making decisions for both quantifiable and qualitative facility impacts.

It is important to distinguish between the economic evaluation of alternative physical facilities and the evaluation of alternative financing plans for a project. The former refers to the evaluation of the cash flow representing the benefits and costs associated with the acquisition and operation of the facility, and this cash flow over the planning horizon is referred to as the *economic cash flow* or the *operating cash flow*. The latter refers to the evaluation of the cash flow representing the incomes and expenditures as a result of adopting a specific financing plan for funding the project, and this cash flow over the planning horizon is referred to as the *financial cash flow*. In general, economic evaluation and financial evaluation are carried out by different groups in an organization since economic evaluation is related to design, construction, operations and maintenance of the facility while financial evaluations require knowledge of financial assets such as equities, bonds, notes and mortgages. The separation of economic evaluation and financial evaluation does not necessarily mean one should ignore the interaction of different designs and financing requirements over time which *may* influence the relative desirability of specific design/financing combinations. All such combinations can be duly considered. In practice, however, the division of labor among two groups of specialists generally leads to sequential decisions without adequate communication for analyzing the interaction of various design/financing combinations because of the timing of separate analyses.

As long as the significance of the interaction of design/financing combinations is understood, it is convenient first to consider the economic evaluation and financial evaluation separately, and then combine the results of both evaluations to reach a final conclusion. Consequently, this chapter is devoted primarily to the economic evaluation of alternative physical facilities while the effects of a variety of financing mechanisms will be treated in the next chapter. Since the methods of analyzing economic cash flows are equally applicable to the analysis of financial cash flows, the *techniques* for evaluating financing plans and the combined effects of economic and financial cash flows for project selection are also included in this chapter.

[Back to top](#)

### 6.2 Basic Concepts of Economic Evaluation

A systematic approach for economic evaluation of facilities consists of the following major steps:

1. Generate a set of projects or purchases for investment consideration.
2. Establish the planning horizon for economic analysis.
3. Estimate the cash flow profile for each project.

4. Specify the minimum attractive rate of return (MARR).
5. Establish the criterion for accepting or rejecting a proposal, or for selecting the best among a group of mutually exclusive proposals, on the basis of the objective of the investment.
6. Perform sensitivity or uncertainty analysis.
7. Accept or reject a proposal on the basis of the established criterion.

It is important to emphasize that many assumptions and policies, some implicit and some explicit, are introduced in economic evaluation by the decision maker. The decision making process will be influenced by the subjective judgment of the management as much as by the result of systematic analysis.

The period of time to which the management of a firm or agency wishes to look ahead is referred to as the *planning horizon*. Since the future is uncertain, the period of time selected is limited by the ability to forecast with some degree of accuracy. For capital investment, the selection of the planning horizon is often influenced by the useful life of facilities, since the disposal of usable assets, once acquired, generally involves suffering financial losses.

In economic evaluations, project alternatives are represented by their cash flow profiles over the  $n$  years or periods in the planning horizon. Thus, the interest periods are normally assumed to be in years  $t = 0, 1, 2, \dots, n$  with  $t = 0$  representing the present time. Let  $B_{t,x}$  be the annual benefit at the end of year  $t$  for a investment project  $x$  where  $x = 1, 2, \dots$  refer to projects No. 1, No. 2, etc., respectively. Let  $C_{t,x}$  be the annual cost at the end of year  $t$  for the same investment project  $x$ . The net annual cash flow is defined as the annual benefit in excess of the annual cost, and is denoted by  $A_{t,x}$  at the end of year  $t$  for an investment project  $x$ . Then, for  $t = 0, 1, \dots, n$ :

$$(6.1) \quad A_{t,x} = B_{t,x} - C_{t,x}$$

where  $A_{t,x}$  is positive, negative or zero depends on the values of  $B_{t,x}$  and  $C_{t,x}$ , both of which are defined as positive quantities.

Once the management has committed funds to a specific project, it must forego other investment opportunities which might have been undertaken by using the same funds. The *opportunity cost* reflects the return that can be earned from the best alternative investment opportunity foregone. The foregone opportunities may include not only capital projects but also financial investments or other socially desirable programs. Management should invest in a proposed project only if it will yield a return at least equal to the minimum attractive rate of return (MARR) from foregone opportunities as envisioned by the organization.

In general, the MARR specified by the top management in a private firm reflects the *opportunity cost of capital* of the firm, the market interest rates for lending and borrowing, and the risks associated with investment opportunities. For public projects, the MARR is specified by a government agency, such as the Office of Management and Budget or the Congress of the United States. The public MARR thus specified reflects social and economic welfare considerations, and is referred to as the *social rate of discount*.

Regardless of how the MARR is determined by an organization, the MARR specified for the economic evaluation of investment proposals is critically important in determining whether any investment proposal is worthwhile from the standpoint of the organization. Since the MARR of an organization often cannot be determined accurately, it is advisable to use several values of the MARR to assess the sensitivity of the potential of the project to variations of the MARR value.

[Back to top](#)

### 6.3 Costs and Benefits of a Constructed Facility

The basic principle in assessing the economic costs and benefits of new facility investments is to find the aggregate of individual changes in the welfare of all parties affected by the proposed projects. The changes in welfare are generally measured in monetary terms, but there are exceptions, since some effects cannot be measured directly by cash receipts and disbursements. Examples include the value of human lives saved through safety improvements or the cost of environmental degradation. The difficulties in estimating future costs and benefits lie not only in uncertainties and reliability of measurement, but also on the social costs and benefits generated as side effects. Furthermore, proceeds and expenditures related to financial transactions, such as interest and subsidies, must also be considered by private firms and by public agencies.

To obtain an accurate estimate of costs in the cash flow profile for the acquisition and operation of a project, it is necessary to specify the resources required to construct and operate the proposed physical facility, given the available technology and operating policy. Typically, each of the labor and material resources required by the facility is multiplied by its price, and the products are then summed to obtain the total costs. Private corporations generally ignore external social costs unless required by law to do so. In the public sector, externalities often must be properly accounted for. An example is the cost of property damage caused by air pollution from a new plant. In any case, the measurement of external costs is extremely difficult and somewhat subjective for lack of a market mechanism to provide even approximate answers to the appropriate value.

In the private sector, the benefits derived from a facility investment are often measured by the revenues generated from the operation of the facility. Revenues are estimated by the total of price times quantity purchased. The depreciation allowances and taxes on revenues must be deducted according to the prevailing tax laws. In the public sector, income may also be accrued to a public agency from the operation of the facility. However, several other categories of benefits may also be included in the evaluation of public projects. First, private benefits can be received by users of a facility or service in excess of costs such as user charges or price charged. After all, individuals only use a service or facility if their private benefit exceeds their cost. These private benefits or *consumer surplus* represent a direct benefit to members of the public. In many public projects, it is difficult, impossible or impractical to charge for services received, so direct revenues equal zero and all user benefits appear as consumers surplus. Examples are a park or roadways for which entrance is free. As a second special category of public benefit, there may be external or secondary beneficiaries of public projects, such as new jobs created and profits to private suppliers. Estimating these secondary benefits is extremely difficult since resources devoted to public projects might simply be displaced from private employment and thus represent no net benefit.

[Back to top](#)

### 6.4 Interest Rates and the Costs of Capital

Constructed facilities are inherently long-term investments with a deferred pay-off. The cost of capital or MARR depends on the real interest rate (i.e., market

interest rate less the inflation rate) over the period of investment. As the cost of capital rises, it becomes less and less attractive to invest in a large facility because of the opportunities foregone over a long period of time.

In Figure 6-1, the changes in the cost of capital from 1974 to 2002 are illustrated. This figure presents the market interest rate on short and long term US treasury borrowing, and the corresponding real interest rate over this period. The *real interest rate* is calculated as the market interest rate less the general rate of inflation. The real interest rates has varied substantially, ranging from 9% to -7%. The exceptional nature of the 1980 to 1985 years is dramatically evident: the real rate of interest reached remarkably high historic levels.

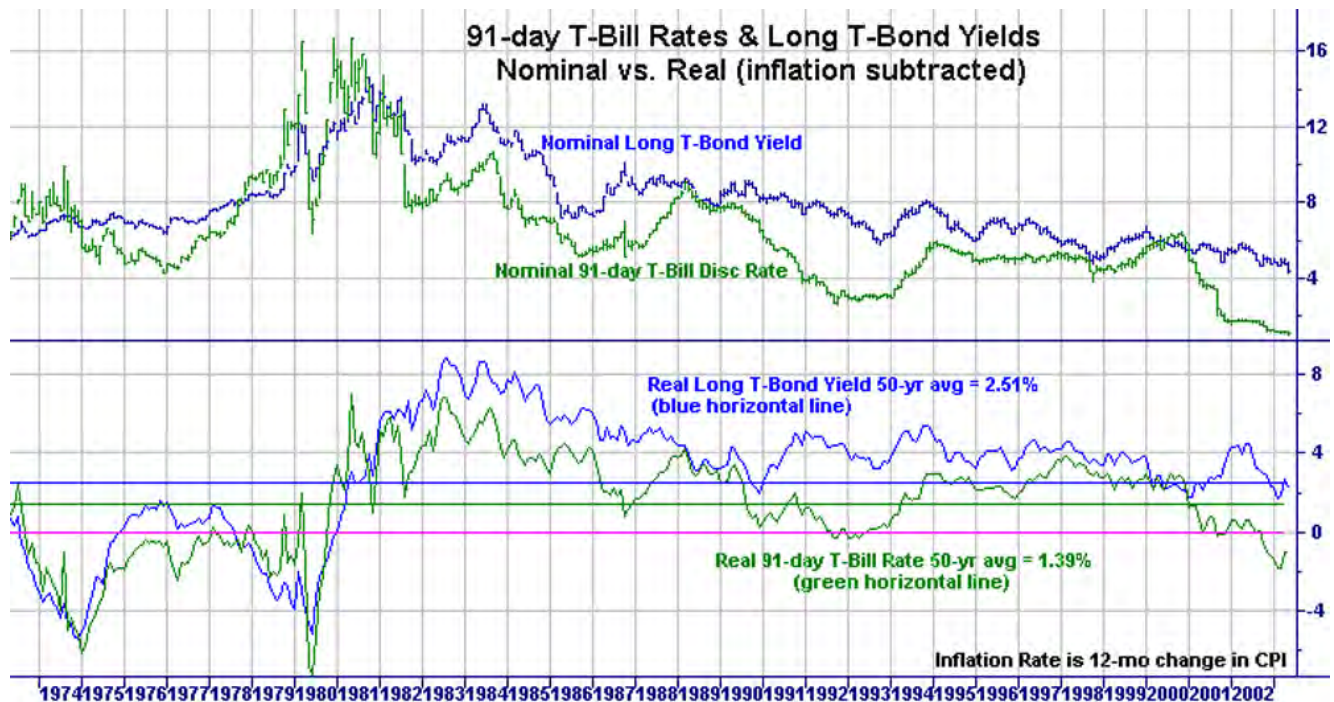

Figure 6-1 Nominal and Real Interest Rates on U.S. Bonds,

With these volatile interest rates, interest charges and the ultimate cost of projects are uncertain. Organizations and institutional arrangements capable of dealing with this uncertainty and able to respond to interest rate changes effectively would be quite valuable. For example, banks offer both fixed rate and variable rate mortgages. An owner who wants to limit its own risk may choose to take a fixed rate mortgage even though the ultimate interest charges may be higher. On the other hand, an owner who chooses a variable rate mortgage will have to adjust its annual interest charges according to the market interest rates.

In economic evaluation, a constant value of MARR over the planning horizon is often used to simplify the calculations. The use of a constant value for MARR is justified on the ground of long-term average of the cost of capital over the period of investment. If the benefits and costs over time are expressed in constant dollars, the constant value for MARR represents the average real interest rate anticipated over the planning horizon; if the benefits and costs over time are expressed in then-current dollars, the constant value for MARR reflects the average market interest rate anticipated over the planning horizon.

[Back to top](#)

## 6.5 Investment Profit Measures

A *profit measure* is defined as an indicator of the desirability of a project from the standpoint of a decision maker. A profit measure may or may not be used as the basis for project selection. Since various profit measures are used by decision makers for different purposes, the advantages and restrictions for using these profit measures should be fully understood.

There are several profit measures that are commonly used by decision makers in both private corporations and public agencies. Each of these measures is intended to be an indicator of profit or net benefit for a project under consideration. Some of these measures indicate the size of the profit at a specific point in time; others give the rate of return per period when the capital is in use or when reinvestments of the early profits are also included. If a decision maker understands clearly the meaning of the various profit measures for a given project, there is no reason why one cannot use all of them for the restrictive purposes for which they are appropriate. With the availability of computer based analysis and commercial software, it takes only a few seconds to compute these profit measures. However, it is important to define these measures precisely:

**1. Net Future Value and Net Present Value.** When an organization makes an investment, the decision maker looks forward to the gain over a planning horizon, against what might be gained if the money were invested elsewhere. A minimum attractive rate of return (MARR) is adopted to reflect this opportunity cost of capital. The MARR is used for compounding the estimated cash flows to the end of the planning horizon, or for discounting the cash flow to the present. The profitability is measured by the net future value (NFV) which is the net return at the end of the planning horizon above what might have been gained by investing elsewhere at the MARR. The net present value (NPV) of the estimated cash flows over the planning horizon is the discounted value of the NFV to the present. A positive NPV for a project indicates the present value of the net gain corresponding to the project cash flows.

**2. Equivalent Uniform Annual Net Value.** The equivalent uniform annual net value (NUV) is a constant stream of benefits less costs at equally spaced time periods over the intended planning horizon of a project. This value can be calculated as the net present value multiplied by an appropriate "capital recovery

factor." It is a measure of the net return of a project on an annualized or amortized basis. The equivalent uniform annual cost (EUAC) can be obtained by multiplying the present value of costs by an appropriate capital recovery factor. The use of EUAC alone presupposes that the discounted benefits of all potential projects over the planning horizon are identical and therefore only the discounted costs of various projects need be considered. Therefore, the EUAC is an indicator of the negative attribute of a project which should be minimized.

**3. Benefit Cost Ratio.** The benefit-cost ratio (BCR), defined as the ratio of discounted benefits to the discounted costs at the same point in time, is a profitability index based on discounted benefits per unit of discounted costs of a project. It is sometimes referred to as the savings-to-investment ratio (SIR) when the benefits are derived from the reduction of undesirable effects. Its use also requires the choice of a planning horizon and a MARR. Since some savings may be interpreted as a negative cost to be deducted from the denominator or as a positive benefit to be added to the numerator of the ratio, the BCR or SIR is not an absolute numerical measure. However, if the ratio of the present value of benefit to the present value of cost exceeds one, the project is profitable irrespective of different interpretations of such benefits or costs.

**4. Internal Rate of Return.** The internal rate of return (IRR) is defined as the discount rate which sets the net present value of a series of cash flows over the planning horizon equal to zero. It is used as a profit measure since it has been identified as the "marginal efficiency of capital" or the "rate of return over cost". The IRR gives the return of an investment *when the capital is in use* as if the investment consists of a single outlay at the beginning and generates a stream of net benefits afterwards. However, the IRR does not take into consideration the reinvestment opportunities related to the timing and intensity of the outlays and returns at the intermediate points over the planning horizon. For cash flows with two or more sign reversals of the cash flows in any period, there may exist multiple values of IRR; in such cases, the multiple values are subject to various interpretations.

**5. Adjusted Internal Rate of Return.** If the financing and reinvestment policies are incorporated into the evaluation of a project, an adjusted internal rate of return (AIRR) which reflects such policies may be a useful indicator of profitability under restricted circumstances. Because of the complexity of financing and reinvestment policies used by an organization over the life of a project, the AIRR seldom can reflect the reality of actual cash flows. However, it offers an approximate value of the yield on an investment for which two or more sign reversals in the cash flows would result in multiple values of IRR. The adjusted internal rate of return is usually calculated as the internal rate of return on the project cash flow modified so that all costs are discounted to the present and all benefits are compounded to the end of the planning horizon.

**6. Return on Investment.** When an accountant reports income in each year of a multi-year project, the stream of cash flows must be broken up into annual rates of return for those years. The return on investment (ROI) as used by accountants usually means the accountant's rate of return for each year of the project duration based on the ratio of the income (revenue less depreciation) for each year and the undepreciated asset value (investment) for that same year. Hence, the ROI is different from year to year, with a very low value at the early years and a high value in the later years of the project.

**7. Payback Period.** The payback period (PBP) refers to the length of time within which the benefits received from an investment can repay the costs incurred during the time in question while ignoring the remaining time periods in the planning horizon. Even the discounted payback period indicating the "capital recovery period" does not reflect the magnitude or direction of the cash flows in the remaining periods. However, if a project is found to be profitable by other measures, the payback period can be used as a secondary measure of the financing requirements for a project.

[Back to top](#)

## 6.6 Methods of Economic Evaluation

The objective of facility investment in the private sector is generally understood to be profit maximization within a specific time frame. Similarly, the objective in the public sector is the maximization of net social benefit which is analogous to profit maximization in private organizations. Given this objective, a method of economic analysis will be judged by the reliability and ease with which a correct conclusion may be reached in project selection.

The basic principle underlying the decision for accepting and selecting investment projects is that if an organization can lend or borrow as much money as it wishes at the MARR, the goal of profit maximization is best served by accepting all independent projects whose net present values based on the specified MARR are nonnegative, or by selecting the project with the maximum nonnegative net present value among a set of mutually exclusive proposals. The net present value criterion reflects this principle and is most straightforward and unambiguous when there is no budget constraint. Various methods of economic evaluation, when properly applied, will produce the same result if the net present value criterion is used as the basis for decision. For convenience of computation, a set of tables for the various compound interest factors is given in Appendix A.

### Net Present Value Method

Let  $BPV_x$  be the present value of benefits of a project  $x$  and  $CPV_x$  be the present value of costs of the project  $x$ . Then, for  $MARR = i$  over a planning horizon of  $n$  years,

$$(6.2) \quad BPV_x = \sum_{t=0}^n B_{t,x} (1+i)^{-t} = \sum_{t=0}^n B_{t,x} (P|F, i, t)$$

$$(6.3) \quad CPV_x = \sum_{t=0}^n C_{t,x} (1+i)^{-t} = \sum_{t=0}^n C_{t,x} (P|F, i, t)$$

where the symbol  $(P|F, i, t)$  is a discount factor equal to  $(1+i)^{-t}$  and reads as follows: "To find the present value  $P$ , given the future value  $F=1$ , discounted at an annual discount rate  $i$  over a period of  $t$  years." When the benefit or cost in year  $t$  is multiplied by this factor, the present value is obtained. Then, the net present value of the project  $x$  is calculated as:

$$(6.4) \quad NPV_x = BPV_x - CPV_x$$

or

$$(6.5) \quad NPV_x = \sum_{t=0}^n (B_{t,x} - C_{t,x})(P|F, i, t) = \sum_{t=0}^n A_{t,x}(P|F, i, t)$$

If there is no budget constraint, then all independent projects having net present values greater than or equal to zero are acceptable. That is, project x is acceptable as long as

$$(6.6) \quad NPV_x \geq 0$$

For mutually exclusive proposals ( $x = 1, 2, \dots, m$ ), a proposal j should be selected if it has the maximum nonnegative net present value among all m proposals, i.e.

$$(6.7) \quad \boxed{\times}$$

provided that  $NPV_j \geq 0$ .

### Net Future Value Method

Since the cash flow profile of an investment can be represented by its equivalent value at any specified reference point in time, the net future value (NFV<sub>x</sub>) of a series of cash flows A<sub>t,x</sub> (for t=0,1,2,...,n) for project x is as good a measure of economic potential as the net present value. Equivalent future values are obtained by multiplying a present value by the compound interest factor (F|P,i,n) which is (1+i)<sup>n</sup>. Specifically,

$$(6.8) \quad NFV_x = NPV_x (1 + i)^n = NPV_x (F|P, i, n)$$

Consequently, if  $NPV_x \geq 0$ , it follows that  $NFV_x \geq 0$ , and vice versa.

### Net Equivalent Uniform Annual Value Method

The *net equivalent uniform annual value* (NUV<sub>x</sub>) refers to a uniform series over a planning horizon of n years whose net present value is that of a series of cash flow A<sub>t,x</sub> (for t= 1,2,...,n) representing project x. That is,

$$(6.9) \quad NUV_x = NPV_x \frac{i(1+i)^n}{(1+i)^n - 1} = NPV_x (U|P, i, n)$$

where the symbol (U|P,i,n) is referred to as the *capital recovery factor* and reads as follows: "To find the equivalent annual uniform amount U, given the present value P=1, discounted at an annual discount rate i over a period of t years." Hence, if  $NPV_x \geq 0$ , it follows that  $NUV_x \geq 0$ , and vice versa.

### Benefit-Cost Ratio Method

The benefit-cost ratio method is not as straightforward and unambiguous as the net present value method but, if applied correctly, will produce the same results as the net present value method. While this method is often used in the evaluation of public projects, the results may be misleading if proper care is not exercised in its application to mutually exclusive proposals.

The *benefit-cost ratio* is defined as the ratio of the discounted benefits to the discounted cost at the same point in time. In view of Eqs. (6.4) and (6.6), it follows that the criterion for accepting an *independent* project on the basis of the benefit-cost ratio is whether or not the benefit-cost ratio is greater than or equal to one:

$$(6.10) \quad \frac{BPV_x}{CPV_x} \geq 1$$

However, a project with the maximum benefit-cost ratio among a group of *mutually exclusive* proposals generally does not necessarily lead to the maximum net benefit. Consequently, it is necessary to perform incremental analysis through pairwise comparisons of such proposals in selecting the best in the group. In effect, pairwise comparisons are used to determine if incremental increases in costs between projects yields larger incremental increases in benefits. This approach is not recommended for use in selecting the best among mutually exclusive proposals.

### Internal Rate of Return Method

The term *internal rate of return method* has been used by different analysts to mean somewhat different procedures for economic evaluation. The method is often misunderstood and misused, and its popularity among analysts in the private sector is undeserved even when the method is defined and interpreted in the most favorable light. The method is usually applied by comparing the MARR to the internal rate of return value(s) for a project or a set of projects.

A major difficulty in applying the internal rate of return method to economic evaluation is the possible existence of multiple values of IRR when there are two or more changes of sign in the cash flow profile  $A_{t,x}$  (for  $t=0,1,2,\dots,n$ ). When that happens, the method is generally not applicable either in determining the acceptance of independent projects or for selection of the best among a group of mutually exclusive proposals unless a set of well defined decision rules are introduced for incremental analysis. In any case, no advantage is gained by using this method since the procedure is cumbersome even if the method is correctly applied. This method is not recommended for use either in accepting independent projects or in selecting the best among mutually exclusive proposals.

### Example 6-1: Evaluation of Four Independent Projects

The cash flow profiles of four independent projects are shown in Table 6-1. Using a MARR of 20%, determine the acceptability of each of the projects on the basis of the net present value criterion for accepting independent projects.

**TABLE 6-1** Cash Flow Profiles of Four Independent Projects (in \$ million)

t	$A_{t,1}$	$A_{t,2}$	$A_{t,3}$	$A_{t,4}$
0	-77.0	-75.3	-39.9	18.0
1	0	28.0	28.0	10.0
2	0	28.0	28.0	-40.0
3	0	28.0	28.0	-60.0
4	0	28.0	28.0	30.0
5	235.0	28.0	-80.0	50.0

Using  $i = 20\%$ , we can compute NPV for  $x = 1, 2, 3$ , and 4 from Eq. (6.5). Then, the acceptability of each project can be determined from Eq. (6.6). Thus,

$$\begin{aligned} [\text{NPV}_1]_{20\%} &= -77 + (235)(\text{P|F}, 20\%, 5) = -77 + 94.4 = 17.4 \\ [\text{NPV}_2]_{20\%} &= -75.3 + (28)(\text{P|U}, 20\%, 5) = -75.3 + 83.7 = 8.4 \\ [\text{NPV}_3]_{20\%} &= -39.9 + (28)(\text{P|U}, 20\%, 4) - (80)(\text{P|F}, 20\%, 5) \\ &= -39.9 + 72.5 - 32.2 = 0.4 \\ [\text{NPV}_4]_{20\%} &= 18 + (10)(\text{P|F}, 20\%, 1) - (40)(\text{P|F}, 20\%, 2) \\ &\quad - (60)(\text{P|F}, 20\%, 3) + (30)(\text{P|F}, 20\%, 4) + (50)(\text{P|F}, 20\%, 5) \\ &= 18 + 8.3 - 27.8 - 34.7 + 14.5 + 20.1 = -1.6 \end{aligned}$$

Hence, the first three independent projects are acceptable, but the last project should be rejected.

It is interesting to note that if the four projects are mutually exclusive, the net present value method can still be used to evaluate the projects and, according to Eq. (6.7), the project ( $x = 1$ ) which has the highest positive NPV should be selected. The use of the net equivalent uniform annual value or the net future value method will lead to the same conclusion. However, the project with the highest benefit-cost ratio is not necessarily the best choice among a group of mutually exclusive alternatives. Furthermore, the conventional internal rate of return method cannot be used to make a meaningful evaluation of these projects as the IRR for both  $x=1$  and  $x=2$  are found to be 25% while multiple values of IRR exist for both the  $x=3$  and  $x=4$  alternatives.

[Back to top](#)

## 6.7 Depreciation and Tax Effects

For private corporations, the cash flow profile of a project is affected by the amount of taxation. In the context of tax liability, *depreciation* is the amount allowed as a deduction due to capital expenses in computing taxable income and, hence, income tax in any year. Thus, depreciation results in a reduction in tax liabilities.

It is important to differentiate between the estimated useful life used in depreciation computations and the actual useful life of a facility. The former is often an arbitrary length of time, specified in the regulations of the U.S. Internal Revenue Service or a comparable organization. The depreciation allowance is a bookkeeping entry that does not involve an outlay of cash, but represents a systematic allocation of the cost of a physical facility over time.

There are various methods of computing depreciation which are acceptable to the U.S. Internal Revenue Service. The different methods of computing depreciation have different effects on the streams of annual depreciation charges, and hence on the stream of taxable income and taxes paid. Let  $P$  be the cost of an asset,  $S$  its estimated salvage value, and  $N$  the estimated useful life (depreciable life) in years. Furthermore, let  $D_t$  denote the depreciation amount in year  $t$ ,  $T_t$  denote the accumulated depreciation up to year  $t$ , and  $B_t$  denote the book value of the asset at the end of year  $t$ , where  $t=1,2,\dots$ , or  $n$  refers to the particular year under consideration. Then,

$$(6.11) \quad T_t = D_1 + D_2 + \dots + D_t$$

and

$$(6.12) \quad B_t = P - T_t = B_{t-1} - D_t$$

The depreciation methods most commonly used to compute  $D_t$  and  $B_t$  are the straight line method, sum-of-the-years'-digits methods, and the double declining balanced method. The U.S. Internal Revenue Service provides tables of acceptable depreciable schedules using these methods. Under straight line depreciation, the net depreciable value resulting from the cost of the facility less salvage value is allocated uniformly to each year of the estimated useful life. Under the sum-of-the-years'-digits (SOYD) method, the annual depreciation allowance is obtained by multiplying the net depreciable value multiplied by a fraction, which has as its numerator the number of years of remaining useful life and its denominator the sum of all the digits from 1 to  $n$ . The annual

depreciation allowance under the double declining balance method is obtained by multiplying the book value of the previous year by a constant depreciation rate  $2/n$ .

To consider tax effects in project evaluation, the most direct approach is to estimate the after-tax cash flow and then apply an evaluation method such as the net present value method. Since projects are often financed by internal funds representing the overall equity-debt mix of the entire corporation, the deductibility of interest on debt may be considered on a corporate-wide basis. For specific project financing from internal funds, let *after-tax* cash flow in year  $t$  be  $Y_t$ . Then, for  $t=0,1,2,\dots,n$ ,

$$(6.13) \quad Y_t = A_t - X_t(A_t - D_t)$$

where  $A_t$  is the net revenue before tax in year  $t$ ,  $D_t$  is the depreciation allowable for year  $t$  and  $X_t$  is the marginal corporate income tax rate in year  $t$ .

Besides corporate income taxes, there are other provisions in the federal income tax laws that affect facility investments, such as tax credits for low-income housing. Since the tax laws are revised periodically, the estimation of tax liability in the future can only be approximate.

#### Example 6-2: Effects of Taxes on Investment

A company plans to invest \$55,000 in a piece of equipment which is expected to produce a uniform annual net revenue before tax of \$15,000 over the next five years. The equipment has a salvage value of \$5,000 at the end of 5 years and the depreciation allowance is computed on the basis of the straight line depreciation method. The marginal income tax rate for this company is 34%, and there is no expectation of inflation. If the after-tax MARR specified by the company is 8%, determine whether the proposed investment is worthwhile, assuming that the investment will be financed by internal funds.

Using Equations (6.11) and (6.13), the after-tax cash flow can be computed as shown in Table 6-2. Then, the net present value discounted at 8% is obtained from Equation (6.5) as follows:

$$[NPV]_{8\%} = -55,000 + \sum_{t=1}^5 (13,300)(P|F, 8\%, t) + (5,000)(P|F, 8\%, 5) = \$1,510$$

The positive result indicates that the project is worthwhile.

**TABLE 6-2** After-Tax Cash Flow Computation

Year $t$	Before-tax Cash Flow $A_t$	Straight-line Depreciation $D_t$	Taxable Income $A_t - D_t$	Income Tax $X_t(A_t - D_t)$	After-Tax Cash-Flow $Y_t$
0	- \$55,000				- \$55,000
1-5 each	+ \$15,000	\$10,000	\$5,000	\$1,700	+ \$13,300
5 only	+ \$5,000				+ \$5,000

[Back to top](#)

## 6.8 Price Level Changes: Inflation and Deflation

In the economic evaluation of investment proposals, two approaches may be used to reflect the effects of future price level changes due to inflation or deflation. The differences between the two approaches are primarily philosophical and can be succinctly stated as follows:

1. The *constant dollar approach*. The investor wants a specified MARR excluding inflation. Consequently, the cash flows should be expressed in terms of base-year or constant dollars, and a discount rate excluding inflation should be used in computing the net present value.
2. The *inflated dollar approach*. The investor includes an inflation component in the specified MARR. Hence, the cash flows should be expressed in terms of then-current or inflated dollars, and a discount rate including inflation should be used in computing the net present value.

If these approaches are applied correctly, they will lead to identical results.

Let  $i$  be the discount rate excluding inflation,  $i'$  be the discount rate including inflation, and  $j$  be the annual inflation rate. Then,

$$(6.14) \quad i' = i + j + ij$$

and

$$(6.15) \quad i = \frac{i' - j}{1 + j}$$

When the inflation rate  $j$  is small, these relations can be approximated by

$$(6.16) \quad i' = i + j \quad \text{or} \quad i = i' - j$$

Note that inflation over time has a compounding effect on the price levels in various periods, as discussed in connection with the cost indices in Chapter 5.

If  $A_t$  denotes the cash flow in year  $t$  expressed in terms of constant (base year) dollars, and  $A'_t$  denotes the cash flow in year  $t$  expressed in terms of inflated (then-current) dollars, then

$$(6.17) \quad NPV = A_0 + \sum_{t=1}^n A_t (1+i)^{-t}$$

or

$$(6.18) \quad NPV = A_0 + \sum_{t=1}^n A'_t (1+i')^{-t}$$

It can be shown that the results from these two equations are identical. Furthermore, the relationship applies to after-tax cash flow as well as to before-tax cash flow by replacing  $A_t$  and  $A'_t$  with  $Y_t$  and  $Y'_t$  respectively in Equations (6.17) and (6.18).

### Example 6-3: Effects of Inflation

Suppose that, in the previous example, the inflation expectation is 5% per year, and the after-tax MARR specified by the company is 8% excluding inflation. Determine whether the investment is worthwhile.

In this case, the before-tax cash flow  $A_t$  in terms of constant dollars at base year 0 is inflated at  $j = 5\%$  to then-current dollars  $A'_t$  for the computation of the taxable income ( $A'_t - D_t$ ) and income taxes. The resulting after-tax flow  $Y'_t$  in terms of then-current dollars is converted back to constant dollars. That is, for  $X_t = 34\%$  and  $D_t = \$10,000$ . The annual depreciation charges  $D_t$  are not inflated to current dollars in conformity with the practice recommended by the U.S. Internal Revenue Service. Thus:

$$\begin{aligned} A'_t &= A_t(1+j)^t = A_t(1+0.05)^t \\ Y'_t &= A'_t - X_t(A'_t - D_t) = A'_t - (34\%)(A'_t - \$10,000) \\ Y_t &= Y'_t(1+j)^t = Y'_t(1+0.05)^t \end{aligned}$$

The detailed computation of the after-tax cash flow is recorded in Table 6-3. The net present value discounted at 8% excluding inflation is obtained by substituting  $Y_t$  for  $A_t$  in Eq. (6.17). Hence,

$$\begin{aligned} [NPV]_{8\%} &= -55,000 + (13,138)(P|F, 8\%, 1) + (12,985)(P|F, 8\%, 2) + (12,837)(P|F, 8\%, 3) \\ &+ (12,697)(P|F, 8\%, 4) + (12,564 + 5,000)(P|F, 8\%, 5) = -\$227 \end{aligned}$$

With 5% inflation, the investment is no longer worthwhile because the value of the depreciation tax deduction is not increased to match the inflation rate.

**TABLE 6-3** After-Tax Cash Flow Including Inflation

Time $t$	Constant \$ B-Tax CF $A_t$	Current \$ B-Tax CF $A'_t$	Current \$ depreciation $D_t$	Current \$ after depreciation $A'_t - D_t$	Current \$ income tax $X_t(A'_t - D_t)$	Current \$ A-Tax CF $Y'_t$	Constant \$ A-Tax CF $Y_t$
0	-\$55,000	+\$55,000				-\$55,000	-\$55,000
1	+15,000	+15,750	\$10,000	\$5,750	\$1,955	+13,795	+13,138
2	+15,000	16,540	10,000	6,540	2,224	+14,316	+12,985
3	+15,000	17,365	10,000	7,365	2,504	+14,861	+12,837
4	+15,000	18,233	10,000	8,233	2,799	+15,434	+12,697
5	+15,000	19,145	10,000	9,145	3,109	+16,036	+12,564
5	+5,000						+5,000

Note: B-Tax CF refers to Before-Tax Cash Flow;  
A-Tax CF refers to After-Tax Cash Flow

### Example 6-4: Inflation and the Boston Central Artery Project

The cost of major construction projects are often reported as simply the sum of all expenses, no matter what year the cost was incurred. For projects extending over a lengthy period of time, this practice can combine amounts of considerably different inherent values. A good example is the Boston Central Artery/Tunnel Project, a very large project to construct or re-locate two Interstate highways within the city of Boston.

In Table 6-4, we show one estimate of the annual expenditures for the Central Artery/Tunnel from 1986 to 2006 in millions of dollars, appearing in the column labelled "Expenses (\$ M)." We also show estimates of construction price inflation in the Boston area for the same period, one based on 1982 dollars (so the price index equals 100 in 1982) and one on 2002 dollars. If the dollar expenditures are added up, the total project cost is \$ 14.6 Billion dollars, which is how the project cost is often reported in summary documents. However, if the cost is calculated in constant 1982 dollars (when the original project cost estimate



was developed for planning purposes), the project cost would be only \$ 8.4 Billion, with price inflation increasing expenses by \$ 6.3 Billion. As with cost indices discussed in Chapter 5, the conversion to 1982 \$ is accomplished by dividing by the 1982 price index for that year and then multiplying by 100 (the 1982 price index value). If the cost is calculated in constant 2002 dollars, the project cost increases to \$ 15.8 Billion. When costs are incurred can significantly affect project expenses!

**TABLE 6-4** Cash Flows for the Boston Central Artery/Tunnel Project

Year t	Price Index 1982 \$	Price Index 2002 \$	Project Expenses (\$ M)	Project Expenses (1982 \$ M)	Project Expenses (2002 \$ M)
1982	100	53			
1983	104	55			
1984	111	59			
1985	118	62			
1986	122	65	33,000	27,000	51,000
1987	123	65	82,000	67,000	126,000
1988	130	69	131,000	101,000	190,000
1989	134	71	164,000	122,000	230,000
1990	140	74	214,000	153,000	289,000
1991	144	76	197,000	137,000	258,000
1992	146	77	246,000	169,000	318,000
1993	154	82	574,000	372,000	703,000
1994	165	88	854,000	517,000	975,000
1995	165	88	852,000	515,000	973,000
1996	165	87	764,000	464,000	877,000
1997	175	93	1,206,000	687,000	1,297,000
1998	172	91	1,470,000	853,000	1,609,000
1999	176	94	1,523,000	863,000	1,629,000
2000	181	96	1,329,000	735,000	1,387,000
2001	183	97	1,246,000	682,000	1,288,000
2002	189	100	1,272,000	674,000	1,272,000
2003	195	103	1,115,000	572,000	1,079,000
2004	202	107	779,000	386,000	729,000
2005	208	110	441,000	212,000	399,000
2006	215	114	133,000	62,000	117,000
Sum			14,625,000	8,370,000	15,797,000

[Back to top](#)

## 6.9 Uncertainty and Risk

Since future events are always uncertain, all estimates of costs and benefits used in economic evaluation involve a degree of uncertainty. Probabilistic methods are often used in decision analysis to determine expected costs and benefits as well as to assess the degree of risk in particular projects.

In estimating benefits and costs, it is common to attempt to obtain the expected or average values of these quantities depending upon the different events which might occur. Statistical techniques such as regression models can be used directly in this regard to provide forecasts of average values. Alternatively, the benefits and costs associated with different events can be estimated and the expected benefits and costs calculated as the sum over all possible events of the resulting benefits and costs multiplied by the probability of occurrence of a particular event:

$$(6.19) \quad E[B_t] = \sum_{q=1}^m (B_{t|q}) Pr\{q\}$$

and

$$(6.20) \quad E[C_t] = \sum_{q=1}^m (C_{t|q}) Pr\{q\}$$

where  $q = 1, \dots, m$  represents possible events,  $(B_{t|q})$  and  $(C_{t|q})$  are benefits and costs respectively in period  $t$  due to the occurrence of  $q$ ,  $Pr\{q\}$  is the probability that  $q$  occurs, and  $E[B_t]$  and  $E[C_t]$  are respectively expected benefit and cost in period  $t$ . Hence, the expected net benefit in period  $t$  is given by:

$$(6.21) \quad E[A_t] = E[B_t] - E[C_t]$$

For example, the average cost of a facility in an earthquake prone site might be calculated as the sum of the cost of operation under normal conditions (multiplied by the probability of no earthquake) plus the cost of operation after an earthquake (multiplied by the probability of an earthquake). Expected benefits and costs can be used directly in the cash flow calculations described earlier.

In formulating objectives, some organizations wish to avoid risk so as to avoid the possibility of losses. In effect, a *risk avoiding* organization might select a project with lower expected profit or net social benefit as long as it had a lower risk of losses. This preference results in a *risk premium* or higher desired profit for risky projects. A rough method of representing a risk premium is to make the desired MARR higher for risky projects. Let  $r_f$  be the risk free market rate of interest as represented by the average rate of return of a safe investment such as U.S. government bonds. However, U.S. government bonds do not protect

from inflationary changes or exchange rate fluctuations, but only insure that the principal and interest will be repaid. Let  $r_p$  be the risk premium reflecting an adjustment of the rate of return for the perceived risk. Then, the risk-adjusted rate of return  $r$  is given by:

$$(6.22) \quad r = r_f + r_p$$

In using the risk-adjusted rate of return  $r$  to compute the net present value of an estimated net cash flow  $A_t$  ( $t = 0, 1, 2, \dots, n$ ) over  $n$  years, it is tacitly assumed that the values of  $A_t$  become more uncertain as time goes on. That is:

$$(6.23) \quad [NPV]_r = \sum_{t=0}^n A_t (1 + r)^{-t}$$

More directly, a decision maker may be confronted with the subject choice among alternatives with different expected benefits of levels of risk such that at a given period  $t$ , the decision maker is willing to exchange an uncertain  $A_t$  with a smaller but certain return  $a_t A_t$  where  $a_t$  is less than one. Consider the decision tree in Figure 6-2 in which the decision maker is confronted with a choice between the certain return of  $a_t A_t$  and a gamble with possible outcomes  $(A_t)_q$  and respective probabilities  $Pr\{q\}$  for  $q = 1, 2, \dots, m$ . Then, the net present value for the series of "certainty equivalents" over  $n$  years may be computed on the basis of the risk free rate. Hence:

$$(6.24) \quad [NPV]_{r_f} = \sum_{t=0}^n (a_t A_t) (1 + r_f)^{-t}$$

Note that if  $r_f r_p$  is negligible in comparison with  $r$ , then

$$(1 + r_p)(1 + r_p) = 1 + r_f + r_p + r_f r_p = 1 + r$$

Hence, for Eq. (6.23)

$$A_t (1 + r)^{-t} = (a_t A_t / a_t) (1 + r_p)^{-t} (1 + r_p)^{-t} = [(a_t A_t) (1 + r_p)^{-t}] [(1 + r_p)^{-t} / a_t]$$

If  $a_t = (1 + r_p)^{-t}$  for  $t = 1, 2, \dots, n$ , then Eqs. (6.23) and (6.24) will be identical. Hence, the use of the risk-adjusted rate  $r$  for computing NPV has the same effect as accepting  $a_t = (1 + r_p)^{-t}$  as a "certainty equivalent" factor in adjusting the estimated cash flow over time.

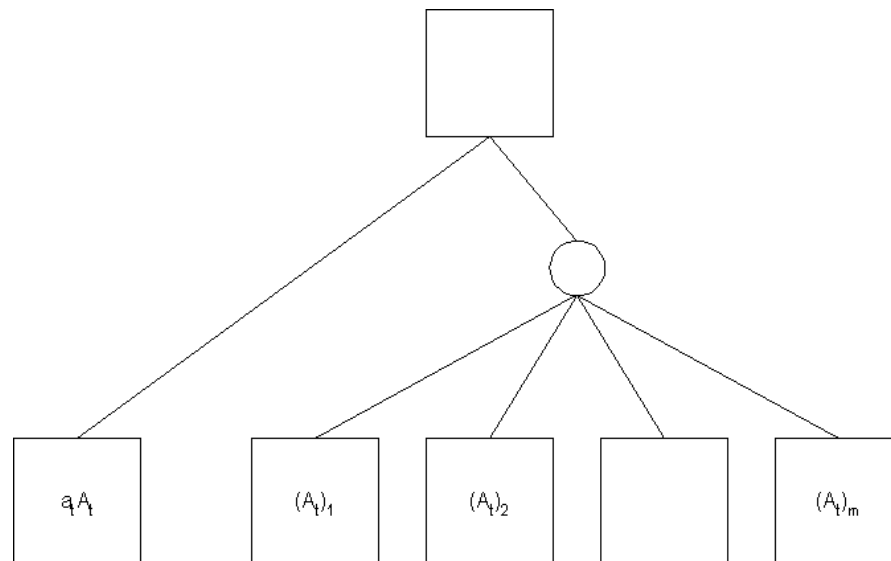

Figure 6-2 Determination of a Certainty Equivalent Value

[Back to top](#)

### 6.10 Effects of Financing on Project Selection

Selection of the best design and financing plans for capital projects is typically done separately and sequentially. Three approaches to facility investment planning most often adopted by an organization are:

1. *Need or demand driven*: Public capital investments are defined and debated in terms of an absolute "need" for particular facilities or services. With a pre-defined "need," design and financing analysis then proceed separately. Even when investments are made on the basis of a demand or revenue analysis of the market, the separation of design and financing analysis is still prevalent.
2. *Design driven*: Designs are generated, analyzed and approved prior to the investigation of financing alternatives, because projects are approved first and only then programmed for eventual funding.
3. *Finance driven*: The process of developing a facility within a particular budget target is finance-driven since the budget is formulated prior to the final design. It is a common procedure in private developments and increasingly used for public projects.

Typically, different individuals or divisions of an organization conduct the analysis for the operating and financing processes. Financing alternatives are sometimes not examined at all since a single mechanism is universally adopted. An example of a single financing plan in the public sector is the use of pay-as-you-go highway trust funds. However, the importance of financial analysis is increasing with the increase of private ownership and private participation in the financing of public projects. The availability of a broad spectrum of new financing instruments has accentuated the needs for better financial analysis in connection with capital investments in both the public and private sectors. While simultaneous assessment of all design and financing alternatives is not always essential, more communication of information between the two evaluation processes would be advantageous in order to avoid the selection of inferior alternatives.

There is an ever increasing variety of borrowing mechanisms available. First, the extent to which borrowing is tied to a particular project or asset may be varied. Loans backed by specific, tangible and fungible assets and with restrictions on that asset's use are regarded as less risky. In contrast, specific project finance may be more costly to arrange due to transactions costs than is general corporate or government borrowing. Also, backing by the full good faith and credit of an organization is considered less risky than investments backed by generally immovable assets. Second, the options of fixed versus variable rate borrowing are available. Third, the repayment schedule and time horizon of borrowing may be varied. A detailed discussion of financing of constructed facilities will be deferred until the next chapter.

As a general rule, it is advisable to borrow as little as possible when borrowing rates exceed the minimum attractive rate of return. Equity or pay-as-you-go financing may be desirable in this case. It is generally preferable to obtain lower borrowing rates, unless borrowing associated with lower rates requires substantial transaction costs or reduces the flexibility for repayment and refinancing. In the public sector, it may be that increasing taxes or user charges to reduce borrowing involves economic costs in excess of the benefits of reduced borrowing costs of borrowed funds. Furthermore, since cash flow analysis is typically conducted on the basis of constant dollars and loan agreements are made with respect to current dollars, removing the effects of inflation will reduce the cost of borrowing. Finally, deferring investments until pay-as-you-go or equity financing are available may unduly defer the benefits of new investments.

It is difficult to conclude unambiguously that one financing mechanism is always superior to others. Consequently, evaluating alternative financing mechanisms is an important component of the investment analysis procedure. One possible approach to simultaneously considering design and financing alternatives is to consider each combination of design and financing options as a specific, mutually exclusive alternative. The cash flow of this combined alternative would be the sum of the economic or operating cash flow (assuming equity financing) and the financial cash flow over the planning horizon.

[Back to top](#)

## 6.11 Combined Effects of Operating and Financing Cash Flows

A general approach for obtaining the combined effects of operating and financing cash flows of a project is to make use of the additive property of net present values by calculating an adjusted net present value. The adjusted net present value (APV) is the sum of the net present value (NPV) of the operating cash flow plus the net present value of the financial cash flow due to borrowing or raising capital (FPV). Thus,

$$(6.25) \quad APV = [NPV]_i + [FPV]_i$$

where each function is evaluated at  $i=MARR$  if both the operating and the financing cash flows have the same degree of risk or if the risks are taken care of in other ways such as by the use of certainty equivalents. Then, project selection involving both design and financing alternatives is accomplished by selecting the combination which has the highest positive adjusted present value. The use of this adjusted net present value method will result in the same selection as an evaluation based on the net present value obtained from the combined cash flow of each alternative combination directly.

To be specific, let  $A_t$  be the net operating cash flow,  $\bar{A}_t$  be the net financial cash flow resulting from debt financing, and  $AA_t$  be the combined net cash flow, all for year  $t$  before tax. Then:

$$(6.26) \quad AA_t = A_t + \bar{A}_t$$

Similarly, let  $\bar{Y}_t$  and  $YY_t$  be the corresponding cash flows after tax such that:

$$(6.27) \quad YY_t = Y_t + \bar{Y}_t$$

The tax shields for interest on borrowing (for  $t = 1, 2, \dots, n$ ) are usually given by

$$(6.28) \quad \bar{Y}_t = \bar{A}_t + X_t I_t$$

where  $I_t$  is the interest paid in year  $t$  and  $X_t$  is the marginal corporate income tax rate in year  $t$ . In view of Eqs. (6.13), (6.27) and (6.28), we obtain

$$(6.29) \quad YY_t = A_t + \bar{A}_t - X_t(A_t - D_t - I_t)$$

When  $MARR = i$  is applied to both the operating and the financial cash flows in Eqs. (6.13) and (6.28), respectively, in computing the net present values, the combined effect will be the same as the net present value obtained by applying  $MARR = i$  to the combined cash flow in Eq. (6.29).

In many instances, a risk premium related to the specified type of operation is added to the MARR for discounting the operating cash flow. On the other hand, the MARR for discounting the financial cash flow for borrowing is often regarded as relatively risk-free because debtors or holders of corporate bonds must be paid first before stockholders in case financial difficulties are encountered by a corporation. Then, the adjusted net present value is given by

$$(6.30) \quad APV = [NPV]_r + [FPV]_{r_f}$$

where NPV is discounted at  $r$  and FPV is obtained from the  $r_f$  rate. Note that the net present value of the financial cash flow includes not only tax shields for interest on loans and other forms of government subsidy, but also on transactions costs such as those for legal and financial services associated with issuing new bonds or stocks.

The evaluation of combined alternatives based on the adjusted net present value method should also be performed in dollar amounts which either consistently include or remove the effects of inflation. The MARR value used would reflect the inclusion or exclusion of inflation accordingly. Furthermore, it is preferable to use after-tax cash flows in the evaluation of projects for private firms since different designs and financing alternatives are likely to have quite different implications for tax liabilities and tax shields.

In theory, the corporate finance process does not necessarily require a different approach than that of the APV method discussed above. Rather than considering single projects in isolation, groups or sets of projects along with financing alternatives can be evaluated. The evaluation process would be to select that group of operating and financing plans which has the highest total APV. Unfortunately, the number of possible combinations to evaluate can become very large even though many combinations can be rapidly eliminated in practice because they are clearly inferior. More commonly, heuristic approaches are developed such as choosing projects with the highest benefit/cost ratio within a particular budget or financial constraint. These heuristic schemes will often involve the separation of the financing and design alternative evaluation. The typical result is design-driven or finance-driven planning in which one or the other process is conducted first.

#### Example 6-5: Combined Effects of Operating and Financing Plans

A public agency plans to construct a facility and is considering two design alternatives with different capacities. The operating net cash flows for both alternatives over a planning horizon of 5 years are shown in Table 6-4. For each design alternative, the project can be financed either through overdraft on bank credit or by issuing bonds spanning over the 5-year period, and the cash flow for each financing alternative is also shown in Table 6-4. The public agency has specified a MARR of 10% for discounting the operating and financing cash flows for this project. Determine the best combination of design and financing plan if

- a design is selected before financing plans are considered, or
- the decision is made simultaneously rather than sequentially.

The net present values (NPV) of all cash flows can be computed by Eq.(6.5), and the results are given at the bottom of Table 6-4. The adjusted net present value (APV) combining the operating cash flow of each design and an appropriate financing is obtained according to Eq. (6.25), and the results are also tabulated at the bottom of Table 6-4.

Under condition (a), design alternative 2 will be selected since  $NPV = \$767,000$  is the higher value when only operating cash flows are considered. Subsequently, bonds financing will be chosen because  $APV = \$466,000$  indicates that it is the best financing plan for design alternative 2.

Under condition (b), however, the choice will be based on the highest value of APV, i.e.,  $APV = \$484,000$  for design alternative one in combination will overdraft financing. Thus, the simultaneous decision approach will yield the best results.

**TABLE 6-5** Illustration of Different Design and Financing Alternatives (in \$ thousands)

Year	Design Alternative One			Design Alternative Two		
	Operating Cash Flow	Overdraft Financing	Bond Financing	Operating Cash Flow	Overdraft Financing	Bond Financing
0	-\$1,000	\$1,000	\$3,653	-\$2,500	\$2,500	\$3,805
1	-2,500	2,500	-418	-1,000	1,000	-435
2	1,000	-1,000	-418	1,000	-1,000	-435
3	1,500	-1,500	-418	1,500	-1,500	-435
4	1,500	-1,500	-418	1,500	-1,500	-435
5	1,700	-921	-4,217	1,930	-1,254	-4,392
NPV or FPV at 10%	761	-277	-290	767	-347	-301
APV = NPV + FPV		484	471		420	466

[Back to top](#)

## 6.12 Public versus Private Ownership of Facilities

In recent years, various organizational ownership schemes have been proposed to raise the level of investment in constructed facilities. For example, independent authorities are assuming responsibility for some water and sewer systems, while private entrepreneurs are taking over the ownership of public buildings such as stadiums and convention centers in joint ventures with local governments. Such ownership arrangements not only can generate the capital for new facilities, but also will influence the management of the construction and operation of these facilities. In this section, we shall review some of these implications.

A particular organizational arrangement or financial scheme is not necessarily superior to all others in each case. Even for similar facilities, these arrangements and schemes may differ from place to place or over time. For example, U.S. water supply systems are owned and operated both by relatively large and small organizations in either the private or public sector. Modern portfolio theory suggest that there may be advantages in using a variety of financial schemes to spread risks. Similarly, small or large organizations may have different relative advantages with respect to personnel training, innovation or other activities.

### Differences in Required Rates of Return

A basic difference between public and private ownership of facilities is that private organizations are motivated by the expectation of profits in making capital investments. Consequently, private firms have a higher minimum attractive rate of return (MARR) on investments than do public agencies. The MARR represents the desired return or profit for making capital investments. Furthermore, private firms often must pay a higher interest rate for borrowing than public agencies because of the tax exempt or otherwise subsidized bonds available to public agencies. International loans also offer subsidized interest rates to qualified agencies or projects in many cases. With higher required rates of return, we expect that private firms will require greater receipts than would a public agency to make a particular investment desirable.

In addition to different minimum attractive rates of return, there is also an important distinction between public and private organizations with respect to their evaluation of investment benefits. For private firms, the returns and benefits to cover costs and provide profit are *monetary revenues*. In contrast, public agencies often consider *total* social benefits in evaluating projects. Total social benefits include monetary user payments plus users' surplus (e.g., the value received less costs incurred by users), external benefits (e.g., benefits to local businesses or property owners) and nonquantifiable factors (e.g., psychological support, unemployment relief, etc.). Generally, total social benefits will exceed monetary revenues.

While these different valuations of benefits may lead to radically different results with respect to the extent of benefits associated with an investment, they do not necessarily require public agencies to undertake such investments directly. First, many public enterprises must fund their investments and operating expenses from user fees. Most public utilities fall into this category, and the importance of user fee financing is increasing for many civil works such as waterways. With user fee financing, the required returns for the public and private firms to undertake the aforementioned investment are, in fact, limited to monetary revenues. As a second point, it is always possible for a public agency to contract with a private firm to undertake a particular project.

All other things being equal, we expect that private firms will require larger returns from a particular investment than would a public agency. From the users or taxpayers point of view, this implies that total payments would be *higher* to private firms for identical services. However, there are a number of mitigating factors to counterbalance this disadvantage for private firms.

### Tax Implications of Public Versus Private Organizations

Another difference between public and private facility owners is in their relative liability for taxes. Public entities are often exempt from taxes of various kinds, whereas private facility owners incur a variety of income, property and excise taxes. However, these private tax liabilities can be offset, at least in part, by tax deductions of various kinds.

For private firms, income taxes represent a significant cost of operation. However, taxable income is based on the gross revenues less all expenses and allowable deductions as permitted by the prevalent tax laws and regulations. The most significant allowable deductions are depreciation and interest. By selecting the method of depreciation and the financing plan which are most favorable, a firm can exert a certain degree of control on its taxable income and, thus, its income tax.

Another form of relief in tax liability is the *tax credit* which allows a direct deduction for income tax purposes of a small percentage of the value of certain newly acquired assets. Although the provisions for investment tax credit for physical facilities and equipment had been introduced at different times in the US federal tax code, they were eliminated in the 1986 Tax Reform Act except a tax credit for low-income housing.

Of course, a firm must have profits to take direct advantage of such tax shields, i.e., tax deductions only reduce tax liabilities if before-tax profits exist. In many cases, investments in constructed facilities have net outlays or losses in the early years of construction. Generally, these losses in early years can be offset against profits occurred elsewhere or later in time. Without such offsetting profits, losses can be carried forward by the firm or merged with other firms' profits, but these mechanisms will not be reviewed here.

### Effects of Financing Plans

Major investments in constructed facilities typically rely upon borrowed funds for a large portion of the required capital investments. For private organizations, these borrowed funds can be useful for leverage to achieve a higher return on the organizations' own capital investment.

For public organizations, borrowing costs which are larger than the MARR results in increased "cost" and higher required receipts. Incurring these costs may be essential if the investment funds are not otherwise available: capital funds must come from somewhere. But it is not unusual for the borrowing rate to exceed the MARR for public organizations. In this case, reducing the amount of borrowing lowers costs, whereas increasing borrowing lowers costs whenever the MARR is greater than the borrowing rate.

Although private organizations generally require a higher rate of return than do public bodies (so that the required receipts to make the investment desirable are higher for the private organization than for the public body), consideration of tax shields and introduction of a suitable financing plan may reduce this difference. The relative levels of the MARR for each group and their borrowing rates are critical in this calculation.

### Effects of Capital Grant Subsidies

An important element in public investments is the availability of capital grant subsidies from higher levels of government. For example, interstate highway

construction is eligible for federal capital grants for up to 90% of the cost. Other programs have different matching amounts, with 50/50 matching grants currently available for wastewater treatment plants and various categories of traffic systems improvement in the U.S. These capital grants are usually made available solely for public bodies and for designated purposes.

While the availability of capital grant subsidies reduces the local cost of projects, the timing of investment can also be affected. In particular, public subsidies may be delayed or spread over a longer time period because of limited funds. To the extent that (discounted) benefits exceed costs for particular benefits, these funding delays can be costly. Consequently, private financing and investment may be a desirable alternative, even if some subsidy funds are available.

### Implications for Design and Construction

Different perspectives and financial considerations also may have implications for design and construction choices. For example, an important class of design decisions arises relative to the trade-off between capital and operating costs. It is often the case that initial investment or construction costs can be reduced, but at the expense of a higher operating costs or more frequent and extensive rehabilitation or repair expenditures. It is this trade-off which has led to the consideration of "life cycle costs" of alternative designs. The financial schemes reviewed earlier can profoundly effect such evaluations.

For financial reasons, it would often be advantageous for a public body to select a more capital intensive alternative which would receive a larger capital subsidy and, thereby, reduce the project's local costs. In effect, the capital grant subsidy would distort the trade-off between capital and operating costs in favor of more capital intensive projects.

The various tax and financing considerations will also affect the relative merits of relatively capital intensive projects. For example, as the borrowing rate increases, more capital intensive alternatives become less attractive. Tax provisions such as the investment tax credit or accelerated depreciation are intended to stimulate investment and thereby make more capital intensive projects relatively more desirable. In contrast, a higher minimum attractive rate of return tends to make more capital intensive projects less attractive.

[Back to top](#)

## 6.13 Economic Evaluation of Different Forms of Ownership

While it is difficult to conclude definitely that one or another organizational or financial arrangement is always superior, different organizations have systematic implications for the ways in which constructed facilities are financed, designed and constructed. Moreover, the selection of alternative investments for constructed facilities is likely to be affected by the type and scope of the decision-making organization.

As an example of the perspectives of public and private organizations, consider the potential investment on a constructed facility with a projected useful life of  $n$  years. Let  $t = 0$  be the beginning of the planning horizon and  $t = 1, 2, \dots, n$  denote the end of each of the subsequent years. Furthermore, let  $C_0$  be the cost of acquiring the facility at  $t = 0$ , and  $C_t$  be the cost of operation in year  $t$ . Then, the net receipts  $A_t$  in year  $t$  is given by  $A_t = B_t - C_t$  in which  $B_t$  is the benefit in year  $t$  and  $A_t$  may be positive or negative for  $t = 0, 1, 2, \dots, n$ .

Let the minimum attractive rate of return (MARR) for the owner of the facility be denoted by  $i$ . Then, the net present value (NPV) of a project as represented by the net cash flow discounted to the present time is given by

$$(6.31) \quad NPV = \sum_{t=0}^n A_t(1+i)^{-t} = \sum_{t=0}^n B_t(1+i)^{-t} - \sum_{t=0}^n C_t(1+i)^{-t}$$

Then, a project is acceptable if  $NPV \geq 0$ . When the annual gross receipt is uniform, i.e.,  $B_t = B$  for  $t = 1, 2, \dots, n$  and  $B_0 = 0$ , then, for  $NPV = 0$ :

$$(6.32) \quad B \sum_{t=1}^n (1+i)^{-t} = \sum_{t=0}^n C_t(1+i)^{-t}$$

Thus, the minimum uniform annual gross receipt  $B$  which makes the project economically acceptable can be determined from Equation (6.32), once the acquisition and operation costs  $C_t$  of the facility are known and the MARR is specified.

### Example 6-6: Different MARRs for Public and Private Organizations

For the facility cost stream of a potential investment with  $n = 7$  in Table 6-5, the required uniform annual gross receipts  $B$  are different for public and private ownerships since these two types of organizations usually choose different values of MARR. With a given value of  $MARR = i$  in each case, the value of  $B$  can be obtained from Eq. (6.32). With a MARR of 10%, a public agency requires at least  $B = \$184,000$ . By contrast, a private firm using a 20% MARR before tax while neglecting other effects such as depreciation and tax deduction would require at least  $B = \$219,000$ . Then, according to Eq. (6.31), the gross receipt streams for both public and private ownerships in Table 6-5 will satisfy the condition  $NPV = 0$  when each of them is netted from the cost stream and discounted at the appropriate value of MARR, i.e., 10% for a public agency and 20% (before tax) for a private firm. Thus, this case suggests that public provision of the facility has lower user costs.

**TABLE 6-6** Required Uniform Annual Gross Receipts for Public and Private Ownership of a Facility (in \$ thousands)

Year $t$	Facility cost, $C_t$	Public Ownership		Private Ownership	
		Gross Receipt, $B_t$	Net Receipt $A_t = B_t - C_t$	Gross Receipt, $B_t$	Net Receipt $A_t = B_t - C_t$
0	\$500	\$0	-\$500	\$0	-\$500
1	76	184	108	219	143

2	78	184	106	219	141
3	80	184	104	219	139
4	82	184	102	219	137
5	84	184	100	219	135
6	86	184	98	219	133
7	88	184	96	219	131

#### Example 6-7: Effects of Depreciation and Tax Shields for Private Firms

Using the same data as in Example 6-6, we now consider the effects of depreciation and tax deduction for private firms. Suppose that the marginal tax rate of the firm is 34% in each year of operation, and losses can always be offset by company-wide profits. Suppose further that the salvage value of the facility is zero at the end of seven years so that the entire amount of cost can be depreciated by means of the sum-of-the-years'-digits (SOYD) method. Thus, for the sum of digits 1 through 7 equal to 28, the depreciation allowances for years 1 to 7 are respectively  $7/28$ ,  $6/28$ , ...,  $1/28$  of the total depreciable value of \$ 500,000, and the results are recorded in column 3 of Table 6-6. For a uniform annual gross receipt  $B = \$219,000$ , the net receipt before tax in Column 6 of Table 6-5 in Example 6-5 can be used as the starting point for computing the after-tax cash flow according to Equation (6.13) which is carried out step-by-step in Table 6-6. (Dollar amounts are given to the nearest \$1,000). By trial and error, it is found that an after-tax MARR = 14.5% will produce a zero value for the net present value of the discounted after-tax flow at  $t = 0$ . In other words, the required uniform annual gross receipt for this project at 14.5% MARR after tax is also  $B = \$219,000$ . It means that the MARR of this private firm must specify a 20% MARR before tax in order to receive the equivalent of 14.5% MARR after tax.

**TABLE 6-7 Effects of Depreciation and Tax Deductions for Private Ownership in a Facility (in \$ thousands)**

Year $t$	Net Receipt Before-tax $A_t$	Depreciation (SOYD) $D_t$	Taxable Income $(A_t - D_t)$	Income Tax $X_t(A_t - D_t)$	After-tax Cash Flow $\bar{Y}_t$
0	-\$500	\$0	\$0	\$0	-\$500
1	143	125	18	6	137
2	141	107	34	12	129
3	139	89	50	17	122
4	137	71	66	22	115
5	135	54	81	28	107
6	133	36	97	33	100
7	131	18	113	38	93

#### Example 6-8: Effects of Borrowing on Public Agencies

Suppose that the gross uniform annual receipt for public ownership is  $B = \$190,000$  instead of \$184,000 for the facility with cost stream given in Column 2 of Table 6-5. Suppose further that the public agency must borrow \$400,000 (80% of the facility cost) at 12% annual interest, resulting in an annual uniform payment of \$88,000 for the subsequent seven years. This information has been summarized in Table 6-7. The use of borrowed funds to finance a facility is referred to as debt financing or leveraged financing, and the combined cash flow resulting from operating and financial cash flows is referred to as the levered cash flow.

To the net receipt  $A_t$  in Column 4 of Table 6-7, which has been obtained from a uniform annual gross receipt of \$190,000, we add the financial cash flow  $\bar{A}_t$ , which included a loan of \$400,000 with an annual repayment of \$88,000 corresponding to an interest rate of 12%. Then the resulting combined cash flow  $AA_t$  as computed according to Equation (6.26) is shown in column 6 of Table 6-7. Note that for a loan at 12% interest, the net present value of the combined cash flow  $AA_t$  is zero when discounted at a 10% MARR for the public agency. This is not a coincidence, but several values of  $B$  have been tried until  $B = \$190,000$  is found to satisfy  $NPV = 0$  at 10% MARR. Hence, the minimum required uniform annual gross receipt is  $B = \$190,000$ .

**TABLE 6-8 Effects of Borrowing on a Publicly Owned Facility (in \$ thousands)**

Year $t$	Gross receipt $B_t$	Facility cost $C_t$	Net receipt (no loan) $A_t$	Loan and payment (12% interest) $\bar{A}_t$	Combined cash flow (12% interest) $AA_t$
0	\$0	\$500	-\$500	+\$400	-\$100
1	190	76	114	-88	26
2	190	78	112	-88	24
3	190	80	110	-88	22
4	190	82	108	-88	20
5	190	84	106	-88	18
6	190	86	104	-88	16
7	190	88	102	-88	14

#### Example 6-9: Effects of Leverage and Tax Shields for Private Organizations

Suppose that the uniform annual gross receipt for a private firm is also  $B = \$190,000$  (the same as that for the public agency in Example 6-7). The salvage value of the facility is zero at the end of seven years so that the entire amount of cost can be depreciated by means of the sum-of-the-years'-digit (SOYD) method. The marginal tax rate of the firm is 34% in each year of operation, and losses can always be offset by company-wide profits. Suppose further that the firm must borrow \$400,000 (80% of the facility cost) at a 12% annual interest, resulting in an annual uniform payment of \$88,000 for the subsequent seven years. The interest charge each year can be computed as 12% of the remaining balance of the loan in the previous year, and the interest charge is deductible from the tax liability.

For  $B = \$190,000$  and a facility cost stream identical to that in Example 6-7, the net receipts before tax  $A_t$  (operating cash flow with no loan) in Table 6-7 can be used as the starting point for analyzing the effects of financial leverage through borrowing. Thus, column 4 of Table 6-7 is reproduced in column 2 of Table 6-8.

The computation of the after-tax cash flow of the private firm including the effects of tax shields for interest is carried out in Table 6-8. The financial - cash stream  $\bar{A}_t$  in Column 4 of Table 6-8 indicates a loan of \$400,000 which is secured at  $t = 0$  for an annual interest of 12%, and results in a series of uniform annual payments of \$88,000 in order to repay the principal and interest. The levered after-tax cash flow  $YY_t$  can be obtained by Eq. (6.29), using the same investment credit, depreciation method and tax rate, and is recorded in Column 7 of Table 6-8. Since the net present value of  $YY_t$  in Column 7 of Table 6-8 discounted at 14.5% happens to be zero, the minimum required uniform annual gross receipt for the potential investment is \$190,000. By borrowing \$400,000 (80% of the facility cost) at 12% annual interest, the investment becomes more attractive to the private firm. This is expected because of the tax shield for the interest and the 12% borrowing rate which is lower than the 14.5% MARR after-tax for the firm.

**TABLE 6-9 Effects of Financial Leverage and Tax Shields on Private Ownership of a Facility (in \$ thousands)**

Year $t$	Net Receipt Before Tax (no loan) $A_t$	Depreciation (SOYD) $D_t$	Loan and Scheduled Payment $\bar{A}_t$	Interest On Loan $I_t$	Income Tax (34% rate) $X_t(A_t - D_t - I_t)$	After Tax Cash Flow (levered) $YY_t$
0	-\$500	\$0	\$400	\$0	\$0	-\$100
1	114	125	-88	48	-19	45
2	112	107	-88	43	-13	37
3	110	89	-88	38	-6	28
4	108	71	-88	32	2	18
5	106	54	-88	25	9	9
6	104	36	-88	18	17	-1
7	102	18	-88	9	26	-12

#### Example 6-10: Comparison of Public and Private Ownership.

In each of the analyses in Examples 6-5 through 6-8, a minimum required uniform annual gross receipt  $B$  is computed for each given condition whether the owner is a public agency or a private firm. By finding the value of  $B$  which will lead to  $NPV = 0$  for the specified MARR for the organization in each case, various organizational effects with or without borrowing can be analyzed. The results are summarized in Table 6-9 for comparison. In this example, public ownership with a 80% loan and a 10% MARR has the same required benefit as private ownership with an identical 80% loan and a 14.5% after-tax MARR.

**TABLE 6-10 Summary effects of Financial Leverage and Tax Shields on Private Ownership**

Organizational condition	Financial arrangement	Minimum benefit required
Public, no tax (MARR = 10%)	No loan	\$184,000
	80% loan at 12% interest	190,000
Private, before tax (MARR = 20%)	No loan	219,000
	80% loan at 12% interest	219,000
Private, after tax (MARR = 14.5%)	No loan	219,000
	80% loan at 12% interest	190,000

[Back to top](#)

## 6.14 References

1. Au, T., "Profit Measures and Methods of Economic Analysis for Capital Project Selection," *ASCE Journal of Management in Engineering*, Vol. 4, No. 3, 1988.
2. Au, T. and T. P. Au, *Engineering Economics for Capital Investment Analysis*, Allyn and Bacon, Newton, MA, 1983.
3. Bierman, H., Jr., and S. Smidt, *The Capital Budgeting Decision*, 5th Ed., Macmillan, New York, 1984.
4. Brealey, R. and S. Myers, *Principles of Corporate Finance*, Second Edition, McGraw-Hill, New York, 1984.
5. Edwards, W.C. and J.F. Wong, "A Computer Model to Estimate Capital and Operating Costs," *Cost Engineering*, Vol. 29, No. 10, 1987, pp. 15-21.
6. Hendrickson, C. and T. Au, "Private versus Public Ownership of Constructed Facilities," *ASCE Journal of Management in Engineering*, Vol. 1, No. 3, 1985, pp. 119-131.
7. Wohl, M. and C. Hendrickson, *Transportation Investment and Pricing Principles*, John Wiley, New York, 1984.

[Back to top](#)

## 6.15 Problems

1. The Salisbury Corporation is considering four mutually exclusive alternatives for a major capital investment project. All alternatives have a useful life of 10 years with no salvage value at the end. Straight line depreciation will be used. The corporation pays federal and state tax at a rate of 34%, and expects an after-tax MARR of 10%. Determine which alternative should be selected, using the NPV method.

	Initial cost	Before-tax uniform annual net benefits
--	--------------	---



Alternatives	(\$million)	(\$million)
1	\$4.0	\$1.5
2	3.5	1.1
3	3.0	1.0
4	3.7	1.3

2. The operating cash flow for the acquisition and maintenance of a clamshell for excavation is given by  $A_t$  in the table below. Three financing plans, each charging a borrowing rate of 8% but having a different method of - repayment, are represented by three different cash flows of  $\bar{A}_t$ . Find the net present value for each of the three combined cash flows  $AA_t$  for operating and financing if the MARR is specified to be 8%.

Year $t$	Operating $A_t$	Financing $\bar{A}_t$		
		(a)	(b)	(c)
0	-\$80,000	\$40,000	\$40,000	\$40,000
1	30,000	-10,020	-3,200	-13,200
2	30,000	-10,020	-3,200	-12,400
3	30,000	-10,020	-3,200	-11,600
4	30,000	-10,020	-3,200	-10,800
5	30,000	-10,020	-43,200	0

3. Find the net present value for each of the three cases in Problem 2 if the MARR is specified to be  
 (a) 5%  
 (b) 10%.
4. Suppose the clamshell in Problem 2 is purchased by a private firm which pays corporate taxes at a rate of 34%. Depreciation is based on the straight line method with no salvage value at the end of five years. If the after-tax MARR of the firm is 8%, find the net present value for each of the combined cash flows for operating and financing, including the interest deduction. The interest payments included in the annual repayments of each of the loans are 8% times the unpaid principal in each year, with the following values:

Year (t)	(a)	(b)	(c)
1	\$800	\$3,200	\$3,200
2	664	3,200	2,400
3	516	3,200	1,600
4	357	3,200	800
5	185	3,200	0

5. An investment in a hauler will cost \$40,000 and have no salvage value at the end of 5 years. The hauler will generate a gross income of \$12,000 per year, but its operating cost will be \$2,000 during the first year, increasing by \$500 per year until it reaches \$5,000 in the fifth year. The straight line depreciation method is used. The tax rate is 34% and the after-tax MARR is 10%. Determine the net present value of the hauler purchase for a five year planning horizon.
6. The Bailey Construction Company is considering the purchase of a diesel power shovel to improve its productivity. The shovel, which costs \$80,000, is expected to produce a before-tax benefit of \$36,000 in the first year, and \$4,000 less in each succeeding year for a total of five years (i.e., before tax benefit of \$32,000 in the second year, \$28,000 in the third year, continuing to \$20,000 in the fifth year). The salvage value of the equipment will be \$5,000 at the end of 5 years. The firm uses the sum-of-years'-digits depreciation for the equipment and has an annual tax rate of 34%. If the MARR after tax is 10%, is the purchase worthwhile?
7. The ABC Corporation is considering the purchase of a number of pipe-laying machines in order to facilitate the operation in a new pipeline project expected to last six years. Each machine will cost \$26,000 and will have no salvage value after the project is complete. The firm uses the straight line depreciation method and pays annual income taxes on profits at the rate of 34%. If the firm's MARR is 8%, which is the minimum uniform annual benefit before tax that must be generated by this machine in order to justify its purchase?
8. The Springdale Corporation plans to purchase a demolition and wrecking machine to save labor costs. The machine costs \$60,000 and has a salvage value of \$10,000 at the end of 5 years. The machine is expected to be in operation for 5 years, and it will be depreciated by the straight line method up to the salvage value. The corporation specifies an after-tax MARR including inflation of 10% and has an income tax rate of 34%. The annual inflation rate is expected to be 5% during the next 5 years. If the uniform annual net benefit before tax in terms of base-year dollars for the next 5 years is \$20,000, is the new investment worthwhile?
9. XYZ Company plans to invest \$2 million in a new plant which is expected to produce a uniform annual net benefit before tax of \$600,000 in terms of the base-year dollars over the next 6 years. The plant has a salvage value of \$250,000 at the end of 6 years and the depreciation allowance is based on the straight line depreciation method. The corporate tax rate is 34%, and the after-tax MARR specified by the firm is 10% excluding inflation. If the annual inflation rate during the next 6 years is expected to be 5%, determine whether the investment is worthwhile.
10. A sewage treatment plant is being planned by a public authority. Two proposed designs require initial and annual maintenance costs as shown below.

Year $t$	Design No. 1 (\$1000s)	Design No. 2 (\$1000s)
0	1,000	900
1-16(each)	150	180

Both designs will last 16 years with no salvage value. The federal government will subsidize 50% of the initial capital cost, and the state government has a policy to subsidize 10% of the annual maintenance cost. The local community intends to obtain a loan to finance 30% of the initial capital cost at a borrowing rate of 10% with sixteen equal annual payments including principal and interest. The MARR for this type of project is 12% reflecting its operating risk. What is the uniform annual revenue that must be collected in the next 16 years to make each of the two designs worthwhile from the view of the local authority? Which design has lower cost from this perspective?

[Previous Chapter](#) | [Table of Contents](#) | [Next Chapter](#)

<a href="#">Go Up to Table of Contents</a>	
<a href="#">Go To Chapter 6 (Economic Evaluation of Facility Investments)</a>	<a href="#">Go To Chapter 8 (Construction Pricing and Contracting)</a>
Financing of Constructed Facilities	
<a href="#">The Financing Problem</a>	
<a href="#">Institutional Arrangements for Facility Financing</a>	
<a href="#">Evaluation of Alternative Financing Plans</a>	
<a href="#">Secured Loans with Bonds, Notes and Mortgages</a>	
<a href="#">Overdraft Accounts</a>	
<a href="#">Refinancing of Debts</a>	
<a href="#">Project versus Corporate Finance</a>	
<a href="#">Shifting Financial Burdens</a>	
<a href="#">Construction Financing for Contractors</a>	
<a href="#">Effects of Other Factors on a Contractor's Profits</a>	
<a href="#">References</a>	
<a href="#">Problems</a>	
<a href="#">Footnotes</a>	

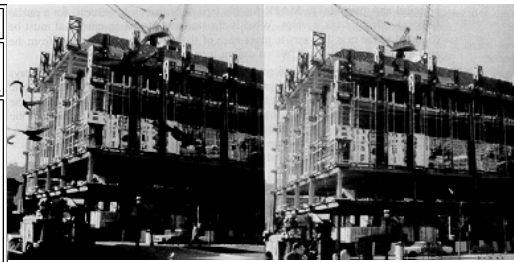

[http://pmbook.ce.cmu.edu/07\\_Financing\\_of\\_Constructed\\_Facilities.html](http://pmbook.ce.cmu.edu/07_Financing_of_Constructed_Facilities.html)

## 7. Financing of Constructed Facilities

### 7.1 The Financing Problem

Investment in a constructed facility represents a cost in the short term that returns benefits only over the long term use of the facility. Thus, costs occur earlier than the benefits, and owners of facilities must obtain the capital resources to finance the costs of construction. A project cannot proceed without adequate financing, and the cost of providing adequate financing can be quite large. For these reasons, attention to project finance is an important aspect of project management. Finance is also a concern to the other organizations involved in a project such as the general contractor and material suppliers. Unless an owner immediately and completely covers the costs incurred by each participant, these organizations face financing problems of their own.

At a more general level, project finance is only one aspect of the general problem of corporate finance. If numerous projects are considered and financed together, then the net cash flow requirements constitutes the corporate financing problem for capital investment. Whether project finance is performed at the project or at the corporate level does not alter the basic financing problem.

In essence, the project finance problem is to obtain funds to bridge the time between making expenditures and obtaining revenues. Based on the conceptual plan, the cost estimate and the construction plan, the cash flow of costs and receipts for a project can be estimated. Normally, this cash flow will involve expenditures in early periods. Covering this negative cash balance in the most beneficial or cost effective fashion is the project finance problem. During planning and design, expenditures of the owner are modest, whereas substantial costs are incurred during construction. Only after the facility is complete do revenues begin. In contrast, a contractor would receive periodic payments from the owner as construction proceeds. However, a contractor also may have a negative cash balance due to delays in payment and *retainage* of profits or cost reimbursements on the part of the owner.

Plans considered by owners for facility financing typically have both long and short term aspects. In the long term, sources of revenue include sales, grants, and tax revenues. Borrowed funds must be eventually paid back from these other sources. In the short term, a wider variety of financing options exist, including borrowing, grants, corporate investment funds, payment delays and others. Many of these financing options involve the participation of third parties such as banks or bond underwriters. For private facilities such as office buildings, it is customary to have completely different financing arrangements during the construction period and during the period of facility use. During the latter period, mortgage or loan funds can be secured by the value of the facility itself. Thus, different arrangements of financing options and participants are possible at different stages of a project, so the practice of financial planning is often complicated.

On the other hand, the options for borrowing by contractors to bridge their expenditures and receipts during construction are relatively limited. For small or medium size projects, overdrafts from bank accounts are the most common form of construction financing. Usually, a maximum limit is imposed on an overdraft account by the bank on the basis of expected expenditures and receipts for the duration of construction. Contractors who are engaged in large projects often own substantial assets and can make use of other forms of financing which have lower interest charges than overdrafting.

In recent years, there has been growing interest in design-build-operate projects in which owners prescribe functional requirements and a contractor handles financing. Contractors are repaid over a period of time from project revenues or government payments. Eventually, ownership of the facilities is transferred to a government entity. An example of this type of project is the Confederation Bridge to Prince Edward Island in Canada.

In this chapter, we will first consider facility financing from the owner's perspective, with due consideration for its interaction with other organizations involved in a project. Later, we discuss the problems of construction financing which are crucial to the profitability and solvency of construction contractors.

[Back to top](#)

### 7.2 Institutional Arrangements for Facility Financing

Financing arrangements differ sharply by type of owner and by the type of facility construction. As one example, many municipal projects are financed in the United States with *tax exempt bonds* for which interest payments to a lender are exempt from income taxes. As a result, tax exempt municipal bonds are available at lower interest charges. Different institutional arrangements have evolved for specific types of facilities and organizations.

A private corporation which plans to undertake large capital projects may use its retained earnings, seek equity partners in the project, issue bonds, offer new stocks in the financial markets, or seek borrowed funds in another fashion. Potential sources of funds would include pension funds, insurance companies, investment trusts, commercial banks and others. Developers who invest in real estate properties for rental purposes have similar sources, plus quasi-governmental corporations such as urban development authorities. Syndicators for investment such as real estate investment trusts (REITs) as well as domestic and foreign pension funds represent relatively new entries to the financial market for building mortgage money.

Public projects may be funded by tax receipts, general revenue bonds, or special bonds with income dedicated to the specified facilities. General revenue bonds would be repaid from general taxes or other revenue sources, while special bonds would be redeemed either by special taxes or user fees collected for the project. Grants from higher levels of government are also an important source of funds for state, county, city or other local agencies.

Despite the different sources of borrowed funds, there is a rough equivalence in the actual cost of borrowing money for particular types of projects. Because lenders can participate in many different financial markets, they tend to switch towards loans that return the highest yield for a particular level of risk. As a result, borrowed funds that can be obtained from different sources tend to have very similar costs, including interest charges and issuing costs.

As a general principle, however, the costs of funds for construction will vary inversely with the risk of a loan. Lenders usually require security for a loan represented by a tangible asset. If for some reason the borrower cannot repay a loan, then the borrower can take possession of the loan security. To the extent that an asset used as security is of uncertain value, then the lender will demand a greater return and higher interest payments. Loans made for projects under construction represent considerable risk to a financial institution. If a lender acquires an unfinished facility, then it faces the difficult task of re-assembling the project team. Moreover, a default on a facility may result if a problem occurs such as foundation problems or anticipated unprofitability of the future facility. As a result of these uncertainties, construction lending for unfinished facilities commands a premium interest charge of several percent compared to mortgage lending for completed facilities.

Financing plans will typically include a reserve amount to cover unforeseen expenses, cost increases or cash flow problems. This reserve can be represented by a special reserve or a contingency amount in the project budget. In the simplest case, this reserve might represent a borrowing agreement with a financial institution to establish a *line of credit* in case of need. For publicly traded bonds, specific reserve funds administered by a third party may be established. The cost of these reserve funds is the difference between the interest paid to bondholders and the interest received on the reserve funds plus any administrative costs.

Finally, arranging financing may involve a lengthy period of negotiation and review. Particularly for publicly traded bond financing, specific legal requirements in the issue must be met. A typical seven month schedule to issue revenue bonds would include the various steps outlined in Table 7-1. [1] In many cases, the speed in which funds may be obtained will determine a project's financing mechanism.

**TABLE 7-1** Illustrative Process and Timing for Issuing Revenue Bonds

Activities	Time of Activities
Analysis of financial alternatives	Weeks 0-4
Preparation of legal documents	Weeks 1-17
Preparation of disclosure documents	Weeks 2-20
Forecasts of costs and revenues	Weeks 4-20
Bond Ratings	Weeks 20-23
Bond Marketing	Weeks 21-24
Bond Closing and Receipt of Funds	Weeks 23-26

#### Example 7-1: Example of financing options

Suppose that you represent a private corporation attempting to arrange financing for a new headquarters building. These are several options that might be considered:

- **Use corporate equity and retained earnings:** The building could be financed by directly committing corporate resources. In this case, no other institutional parties would be involved in the finance. However, these corporate funds might be too limited to support the full cost of construction.
- **Construction loan and long term mortgage:** In this plan, a loan is obtained from a bank or other financial institution to finance the cost of construction. Once the building is complete, a variety of institutions may be approached to supply mortgage or long term funding for the building. This financing plan would involve both short and long term borrowing, and the two periods might involve different lenders. The long term funding would have greater security since the building would then be complete. As a result, more organizations might be interested in providing funds (including pension funds) and the interest charge might be lower. Also, this basic financing plan might be supplemented by other sources such as corporate retained earnings or assistance from a local development agency.
- **Lease the building from a third party:** In this option, the corporation would contract to lease space in a headquarters building from a developer. This developer would be responsible for obtaining funding and arranging construction. This plan has the advantage of minimizing the amount of funds borrowed by the corporation. Under terms of the lease contract, the corporation still might have considerable influence over the design of the headquarters building even though the developer was responsible for design and construction.
- **Initiate a Joint Venture with Local Government:** In many areas, local governments will help local companies with major new ventures such as a new headquarters. This help might include assistance in assembling property, low interest loans or property tax reductions. In the extreme, local governments may force sale of land through their power of *eminent domain* to assemble necessary plots.

[Back to top](#)

## 7.3 Evaluation of Alternative Financing Plans

Since there are numerous different sources and arrangements for obtaining the funds necessary for facility construction, owners and other project participants require some mechanism for evaluating the different potential sources. The relative costs of different financing plans are certainly important in this regard. In addition, the flexibility of the plan and availability of reserves may be critical. As a project manager, it is important to assure adequate financing to complete a project. Alternative financing plans can be evaluated using the same techniques that are employed for the evaluation of investment alternatives.

As described in Chapter 6, the availability of different financing plans can affect the selection of alternative projects. A general approach for obtaining the combined effects of operating and financing cash flows of a project is to determine the adjusted net present value (APV) which is the sum of the net present value of the operating cash flow (NPV) and the net present value of the financial cash flow (FPV), discounted at their respective minimum attractive rates of return (MARR), i.e.,

$$(7.1) \quad APV = [NPV]_r + [FPV]_{r_f}$$

where  $r$  is the MARR reflecting the risk of the operating cash flow and  $r_f$  is the MARR representing the cost of borrowing for the financial cash flow. Thus,

$$(7.2) \quad APV = \sum_{t=0}^n \frac{A_t}{(1+r)^t} + \sum_{t=0}^n \frac{\bar{A}_t}{(1+r_f)^t}$$

where  $A_t$  and  $\bar{A}_t$  are respectively the operating and financial cash flows in period  $t$ .

For the sake of simplicity, we shall emphasize in this chapter the evaluation of financing plans, with occasional references to the combined effects of operating and financing cash flows. In all discussions, we shall present various financing schemes with examples limiting to cases of before-tax cash flows discounted at a before-tax MARR of  $r = r_f$  for both operating and financial cash flows. Once the basic concepts of various financing schemes are clearly understood, their application to more complicated situations involving depreciation, tax liability and risk factors can be considered in combination with the principles for dealing with such topics enunciated in Chapter 6.

In this section, we shall concentrate on the computational techniques associated with the most common types of financing arrangements. More detailed descriptions of various financing schemes and the comparisons of their advantages and disadvantages will be discussed in later sections.

Typically, the interest rate for borrowing is stated in terms of *annual percentage rate* (A.P.R.), but the interest is accrued according to the rate for the interest period specified in the borrowing agreement. Let  $i_p$  be the nominal annual percentage rate, and  $i$  be the interest rate for each of the  $p$  interest periods per year. By definition

$$(7.3) \quad i = \frac{i_p}{p}$$

If interest is accrued semi-annually, i.e.,  $p = 2$ , the interest rate per period is  $i_p/2$ ; similarly if the interest is accrued monthly, i.e.,  $p = 12$ , the interest rate per period is  $i_p/12$ . On the other hand, the effective annual interest rate  $i_e$  is given by:

$$(7.4) \quad i_e = (1 + i)^p - 1 = \left(1 + \frac{i_p}{p}\right)^p - 1$$

Note that the effective annual interest rate,  $i_e$ , takes into account compounding within the year. As a result,  $i_e$  is greater than  $i_p$  for the typical case of more than one compounding period per year.

For a coupon bond, the face value of the bond denotes the amount borrowed (called *principal*) which must be repaid in full at a maturity or due date, while each coupon designates the interest to be paid periodically for the total number of coupons covering all periods until maturity. Let  $Q$  be the amount borrowed, and  $I_p$  be the interest payment per period which is often six months for coupon bonds. If the coupon bond is prescribed to reach maturity in  $n$  years from the date of issue, the total number of interest periods will be  $pn = 2n$ . The semi-annual interest payment is given by:

$$(7.5) \quad i_p = iQ = i_p \frac{Q}{2}$$

In purchasing a coupon bond, a discount from or a premium above the face value may be paid.

An alternative loan arrangement is to make a series of uniform payments including both interest and part of the principal for a pre-defined number of repayment periods. In the case of uniform payments at an interest rate  $i$  for  $n$  repayment periods, the uniform repayment amount  $U$  is given by:

$$(7.6) \quad U = Q \frac{i(1+i)^n}{(1+i)^n - 1} = Q(U|P, i, n)$$

where  $(U|P, i, n)$  is a capital recovery factor which reads: "to find  $U$ , given  $P=1$ , for an interest rate  $i$  over  $n$  periods." Compound interest factors are as tabulated in Appendix A. The number of repayment periods  $n$  will clearly influence the amounts of payments in this uniform payment case. Uniform payment bonds or mortgages are based on this form of repayment.

Usually, there is an origination fee associated with borrowing for legal and other professional services which is payable upon the receipt of the loan. This fee may appear in the form of issuance charges for revenue bonds or percentage point charges for mortgages. The borrower must allow for such fees in addition to the construction cost in determining the required original amount of borrowing. Suppose that a sum of  $P_0$  must be reserved at  $t=0$  for the construction cost, and  $K$  is the origination fee. Then the original loan needed to cover both is:

$$(7.7) \quad Q_0 = P_0 + K$$

If the origination fee is expressed as  $k$  percent of the original loan, i.e.,  $K = kQ_0$ , then:

$$(7.8) \quad Q_0 = \frac{P_0}{1 - k}$$

Since interest and sometimes parts of the principal must be repaid periodically in most financing arrangements, an amount  $Q$  considerably larger than  $Q_0$  is usually borrowed in the beginning to provide adequate reserve funds to cover interest payments, construction cost increases and other unanticipated shortfalls. The net amount received from borrowing is deposited in a separate interest bearing account from which funds will be withdrawn periodically for necessary payments. Let the borrowing rate per period be denoted by  $i$  and the interest for the running balance accrued to the project reserve account be denoted by  $h$ . Let  $A_t$  be the net operating cash flow for - period  $t$  (negative for construction cost in period  $t$ ) and  $\bar{A}_t$  be the net financial cash flow in period  $t$  (negative for payment of interest or principal or a combination of both). Then, the running balance  $N_t$  of the project reserve account can be determined by noting that at  $t=0$ ,

$$(7.9) \quad N_0 = Q - K + A_0$$

and at  $t = 1, 2, \dots, n$ :

$$(7.10) \quad N_t = (1 + h)N_{t-1} + A_t + \bar{A}_t$$

where the value of  $A_t$  or  $\bar{A}_t$  may be zero for some period(s). Equations (7.9) and (7.10) are approximate in that interest might be earned on intermediate balances based on the pattern of payments during a period instead of at the end of a period.

Because the borrowing rate  $i$  will generally exceed the investment rate  $h$  for the running balance in the project account and since the origination fee increases with the amount borrowed, the financial planner should minimize the amount of money borrowed under this finance strategy. Thus, there is an optimal value for  $Q$  such that all estimated shortfalls are covered, interest payments and expenses are minimized, and adequate reserve funds are available to cover unanticipated factors such as construction cost increases. This optimal value of  $Q$  can either be identified analytically or by trial and error.

Finally, variations in ownership arrangements may also be used to provide at least partial financing. Leasing a facility removes the need for direct financing of the facility. Sale-leaseback involves sale of a facility to a third party with a separate agreement involving use of the facility for a pre-specified period of time. In one sense, leasing arrangements can be viewed as a particular form of financing. In return for obtaining the use of a facility or piece of equipment, the user (lesser) agrees to pay the owner (lessor) a lease payment every period for a specified number of periods. Usually, the lease payment is at a fixed level due every month, semi-annually, or annually. Thus, the cash flow associated with the equipment or facility use is a series of uniform payments. This cash flow would be identical to a cash flow resulting from financing the facility or purchase with sufficient borrowed funds to cover initial construction (or purchase) and with a repayment schedule of uniform amounts. Of course, at the end of the lease period, the ownership of the facility or equipment would reside with the lesser. However, the lease terms may include a provision for transferring ownership to the lesser after a fixed period.

#### Example 7-2: A coupon bond cash flow and cost

A private corporation wishes to borrow \$10.5 million for the construction of a new building by issuing a twenty-year coupon bond at an annual percentage interest rate of 10% to be paid semi-annually, i.e. 5% per interest period of six months. The principal will be repaid at the end of 20 years. The amount borrowed will cover the construction cost of \$10.331 million and an origination fee of \$169,000 for issuing the coupon bond.

The interest payment per period is  $(5\%)(10.5) = \$0.525$  million over a life time of  $(2)(20) = 40$  interest periods. Thus, the cash flow of financing by the coupon bond consists of a \$10.5 million receipt at period 0,  $-\$0.525$  million each for periods 1 through 40, and an additional  $-\$10.5$  million for period 40. Assuming a MARR of 5% per period, the net present value of the financial cash flow is given by:

$$[FPV]_{5\%} = 10.5 - (0.525)(P|U, 5\%, 40) - (10.5)(P|F, 5\%, 40) = 0$$

This result is expected since the corporation will be indifferent between borrowing and diverting capital from other uses when the MARR is identical to the borrowing rate. Note that the effective annual rate of the bond may be computed according to Eq.(7.4) as follows:

$$i_e = (1 + 0.05)^2 - 1 = 0.1025 = 10.25\%$$

If the interest payments were made only at the end of each year over twenty years, the annual payment should be:

$$0.525(1 + 0.05) + 0.525 = 1.076$$

where the first term indicates the deferred payment at the mid-year which would accrue interest at 5% until the end of the year, then:

$$[FPV]_{10.25\%} = 10.5 - (1.076)(P|U, 10.25\%, 20) - (10.5)(P|F, 10.25\%, 20) = 0$$

In other words, if the interest is paid at 10.25% annually over twenty years of the loan, the result is equivalent to the case of semi-annual interest payments at 5% over the same lifetime.

#### Example 7-3: An example of leasing versus ownership analysis

Suppose that a developer offered a building to a corporation for an annual lease payment of \$10 million over a thirty year lifetime. For the sake of simplicity, let us assume that the developer also offers to donate the building to the corporation at the end of thirty years or, alternatively, the building would then have no commercial value. Also, suppose that the initial cost of the building was \$65.66 million. For the corporation, the lease is equivalent to receiving a loan with uniform payments over thirty years at an interest rate of 15% since the present value of the lease payments is equal to the initial cost at this interest rate:

$$\sum_{t=1}^{30} \frac{10}{(1.15)^t} = (\$10 \text{ million})(P|U, 15\%, 30) = \$65.66 \text{ million}$$

If the minimum attractive rate of return of the corporation is greater than 15%, then this lease arrangement is advantageous as a financing scheme since the net present value of the leasing cash flow would be less than the cash flow associated with construction from retained earnings. For example, with MARR equal to 20%:

$$[\text{FPV}]_{20\%} = \$65.66 \text{ million} - (\$10 \text{ million})(P|U, 20\%, 30) = \$15.871 \text{ million}$$

On the other hand, with MARR equal to 10%:

$$[\text{FPV}]_{10\%} = \$65.66 \text{ million} - (\$10 \text{ million})(P|U, 10\%, 30) = \$28.609 \text{ million}$$

and the lease arrangement is not advantageous.

#### Example 7-4: Example evaluation of alternative financing plans.

Suppose that a small corporation wishes to build a headquarters building. The construction will require two years and cost a total of \$12 million, assuming that \$5 million is spent at the end of the first year and \$7 million at the end of the second year. To finance this construction, several options are possible, including:

- Investment from retained corporate earnings;
- Borrowing from a local bank at an interest rate of 11.2% with uniform annual payments over twenty years to pay for the construction costs. The shortfalls for repayments on loans will come from corporate earnings. An origination fee of 0.75% of the original loan is required to cover engineer's reports, legal issues, etc; or
- A twenty year coupon bond at an annual interest rate of 10.25% with interest payments annually, repayment of the principal in year 20, and a \$169,000 origination fee to pay for the construction cost only.

The current corporate MARR is 15%, and short term cash funds can be deposited in an account having a 10% annual interest rate.

The first step in evaluation is to calculate the required amounts and cash flows associated with these three alternative financing plans. First, investment using retained earnings will require a commitment of \$5 million in year 1 and \$7 million in year 2.

Second, borrowing from the local bank must yield sufficient funds to cover both years of construction plus the issuing fee. With the unused fund accumulating interest at a rate of 10%, the amount of dollars needed at the beginning of the first year for future construction cost payments is:

$$P_0 = (\$5 \text{ million})/(1.1) + (\$7 \text{ million})/(1.1)^2 = \$10.331 \text{ million}$$

Discounting at ten percent in this calculation reflects the interest earned in the intermediate periods. With a 10% annual interest rate, the accrued interests for the first two years from the project account of \$10.331 at  $t=0$  will be:

$$\text{Year 1: } I_1 = (10\%)(\$10.331 \text{ million}) = \$1.033 \text{ million}$$

$$\text{Year 2: } I_2 = (10\%)(\$10.331 \text{ million} + \$1.033 \text{ million} - \$5.0 \text{ million}) = 0.636 \text{ million}$$

Since the issuance charge is 0.75% of the loan, the amount borrowed from the bank at  $t=0$  to cover both the construction cost and the issuance charge is

$$Q_0 = (\$10.331 \text{ million})/(1 - 0.0075) = \$ 10.409 \text{ million}$$

The issuance charge is  $10.409 - 10.331 = \$ 0.078$  million or \$78,000. If this loan is to be repaid by annual uniform payments from corporate earnings, the amount of each payment over the twenty year life time of the loan can be calculated by Eq. (7.6) as follows:

$$U = (\$10.409 \text{ million})[(0.112)(1.112)^{20}]/[(1.112)^{20} - 1] = \$1.324 \text{ million}$$

Finally, the twenty-year coupon bond would have to be issued in the amount of \$10.5 million which will reflect a higher origination fee of \$169,000. Thus, the amount for financing is:

$$Q_0 = \$10.331 \text{ million} + \$0.169 \text{ million} = \$10.5 \text{ million}$$

With an annual interest charge of 10.25% over a twenty year life time, the annual payment would be \$1.076 million except in year 20 when the sum of principal and interest would be  $10.5 + 1.076 = \$11.576$  million. The computation for this case of borrowing has been given in Example 7-2.

Table 7-2 summarizes the cash flows associated with the three alternative financing plans. Note that annual incomes generated from the use of this building have not been included in the computation. The adjusted net present value of the combined operating and financial cash flows for

each of the three plans discounted at the corporate MARR of 15% is also shown in the table. In this case, the coupon bond is the least expensive financing plan. Since the borrowing rates for both the bank loan and the coupon bond are lower than the corporate MARR, these results are expected.

**TABLE 7-2** Cash Flow Illustration of Three Alternative Financing Plans (in \$ millions)

Year	Source	Retained Earnings	Bank Loan	Coupon Bond
0	Principal	-	\$10.409	\$10.500
0	Issuing Cost	-	- 0.078	- 0.169
1	Earned Interest	-	1.033	1.033
1	Contractor Payment	- 5.000	- 5.000	- 5.000
1	Loan Repayment	-	- 1.324	- 1.076
2	Earned Interest	-	0.636	0.636
2	Contractor Payment	- 7.000	- 7.000	- 7.000
2	Loan Repayment	-	- 1.324	- 1.076
3-19	Loan Repayment	-	- 1.324	-1.076
20	Loan Repayment	-	- 1.324	- 11.576
[APV] <sub>15%</sub>		- 9.641	- 6.217	- 5.308

[Back to top](#)

## 7.4 Secured Loans with Bonds, Notes and Mortgages

Secured lending involves a contract between a borrower and lender, where the lender can be an individual, a financial institution or a trust organization. Notes and mortgages represent formal contracts between financial institutions and owners. Usually, repayment amounts and timing are specified in the loan agreement. Public facilities are often financed by bond issues for either specific projects or for groups of projects. For publicly issued bonds, a trust company is usually designated to represent the diverse bond holders in case of any problems in the repayment. The borrowed funds are usually secured by granting the lender some rights to the facility or other assets in case of defaults on required payments. In contrast, corporate bonds such as debentures can represent loans secured only by the good faith and credit worthiness of the borrower.

Under the terms of many bond agreements, the borrower reserves the right to repurchase the bonds at any time before the maturity date by repaying the principal and all interest up to the time of purchase. The required repayment  $R_c$  at the end of period  $c$  is the net future value of the borrowed amount  $Q$  - less the payment  $\bar{A}_t$  made at intermediate periods compounded at the borrowing rate  $i$  to period  $c$  as follows:

$$(7.11) \quad R_c = Q(1+i)^c - \sum_{t=1}^c \bar{A}_t (1+i)^{c-t}$$

The required repayment  $R_c$  at the end of the period  $c$  can also be obtained by noting the net present value of the repayments in the remaining  $(n-c)$  periods discounted at the borrowing rate  $i$  to  $t=c$  as follows:

$$(7.12) \quad R_c = \sum_{t=1}^{n-c} \frac{\bar{A}_t}{(1+i)^t}$$

For coupon bonds, the required repayment  $R_c$  after the redemption of the coupon at the end of period  $c$  is simply the original borrowed amount  $Q$ . For uniform payment bonds, the required repayment  $R_c$  after the last payment at the end of period  $c$  is:

$$(7.13) \quad R_c = \sum_{t=1}^{n-c} \frac{U}{(1+i)^t} = U(P|U, i, n-c)$$

Many types of bonds can be traded in a secondary market by the bond holder. As interest rates fluctuate over time, bonds will gain or lose in value. The actual value of a bond is reflected in the market discount or premium paid relative to the original principal amount (the face value). Another indicator of this value is the *yield to maturity* or *internal rate of return* of the bond. This yield is calculated by finding the interest rate that sets the (discounted) future cash flow of the bond equal to the current market price:

$$(7.14) \quad V_c = \sum_{t=1}^{n-c} \frac{\bar{A}_t}{(1+r)^t}$$

where  $V_c$  is the current market value after  $c$  periods have lapsed since the - issuance of the bond,  $\bar{A}_t$  is the bond cash flow in period  $t$ , and  $r$  is the market yield. Since all the bond cash flows are positive after the initial issuance, only one value of the yield to maturity will result from Eq. (7.14).



Several other factors come into play in evaluation of bond values from the lenders point of view, however. First, the lender must adjust for the possibility that the borrower may default on required interest and principal payments. In the case of publicly traded bonds, special rating companies divide bonds into different categories of risk for just this purpose. Obviously, bonds that are more likely to default will have a lower value. Secondly, lenders will typically make adjustments to account for changes in the tax code affecting their after-tax return from a bond. Finally, expectations of future inflation or deflation as well as exchange rates will influence market values.

Another common feature in borrowing agreements is to have a variable interest rate. In this case, interest payments would vary with the overall market interest rate in some pre-specified fashion. From the borrower's perspective, this is less desirable since cash flows are less predictable. However, variable rate loans are typically available at lower interest rates because the lenders are protected in some measure from large increases in the market interest rate and the consequent decrease in value of their expected repayments. Variable rate loans can have floors and ceilings on the applicable interest rate or on rate changes in each year.

#### Example 7-5: Example of a corporate promissory note

A corporation wishes to consider the option of financing the headquarters building in Example 7-4 by issuing a five year promissory note which requires an origination fee for the note is \$25,000. Then a total borrowed amount needed at the beginning of the first year to pay for the construction costs and origination fee is  $10.331 + 0.025 = \$10.356$  million. Interest payments are made annually at an annual rate of 10.8% with repayment of the principal at the end of the fifth year. Thus, the annual interest payment is  $(10.8\%)(10.356) = \$1.118$  million. With the data in Example 7-4 for construction costs and accrued interests for the first two year, the combined operating and and financial cash flows in million dollars can be obtained:

$$\begin{aligned} \text{Year 0, } AA_0 &= 10.356 - 0.025 = 10.331 \\ \text{Year 1, } AA_1 &= 1.033 - 5.0 - 1.118 = -5.085 \\ \text{Year 2, } AA_2 &= 0.636 - 7.0 - 1.118 = -7.482 \\ \text{Year 3, } AA_3 &= -1.118 \\ \text{Year 4, } AA_4 &= -1.118 \\ \text{Year 5, } AA_5 &= -1.118 - 10.356 = -11.474 \end{aligned}$$

At the current corporate MARR of 15%,

$$[APV]_{15\%} = \sum_{t=0}^5 \frac{AA_t}{(1.15)^t} = -6.828$$

which is inferior to the 20-year coupon bond analyzed in Table 7-3.

For this problem as well as for the financing arrangements in Example 7-4, the project account is maintained to pay the construction costs only, while the interest and principal payments are repaid from corporate earnings. - Consequently, the  $\bar{A}_t$  terms in Eq. (7.10) will disappear when the account balance in each period is computed for this problem:

$$\begin{aligned} \text{At } t=0, N_0 &= 10.356 - 0.025 = \$10.331 \text{ million} \\ \text{At } t=1, N_1 &= (1 + 0.1)(10.331) - 5.0 = \$6.364 \text{ million} \\ \text{At } t=2, N_2 &= (1 + 0.1)(6.364) - 7.0 = \$0 \end{aligned}$$

#### Example 7-6: Bond financing mechanisms.

Suppose that the net operating expenditures and receipts of a facility investment over a five year time horizon are as shown in column 2 of Table 7-3 in which each period is six months. This is a hypothetical example with a deliberately short life time period to reduce the required number of calculations. Consider two alternative bond financing mechanisms for this project. Both involve borrowing \$2.5 million at an issuing cost of five percent of the loan with semi-annual repayments at a nominal annual interest rate of ten percent i.e., 5% per period. Any excess funds can earn an interest of four percent each semi-annual period. The coupon bond involves only interest payments in intermediate periods, plus the repayment of the principal at the end, whereas the uniform payment bond requires ten uniform payments to cover both interests and the principal. Both bonds are subject to optional redemption by the borrower before maturity.

The operating cash flow in column 2 of Table 7-3 represents the construction expenditures in the early periods and rental receipts in later periods over the lifetime of the facility. By trial and error with Eqs. (7.9) and (7.10), it can be found that  $Q = \$2.5$  million ( $K = \$0.125$  or 5% of  $Q$ ) is necessary to insure a nonnegative balance in the project account for the uniform payment bond, as shown in Column 6 of Table 7-3. For the purpose of comparison, the same amount is borrowed for the coupon bond option even though a smaller loan will be sufficient for the construction expenditures in this case.

The financial cash flow of the coupon bond can easily be derived from  $Q = \$2.5$  million and  $K = \$0.125$  million. Using Eq. (7.5),  $I_p = (5\%)(2.5) = \$0.125$  million, and the repayment in Period 10 is  $Q + I_p = \$2.625$  million as shown in Column 3 of Table 7-3. The account balance for the coupon bond in Column 4 is obtained from Eqs. (7.9) and (7.10). On the other hand, the uniform annual payment  $U = \$0.324$  million for the financial cash flow of the uniform payment bond (Column 5) can be obtained from Eq. (7.6), and the bond account for this type of balance is computed by Eqs. (7.9) and (7.10).

Because of the optional redemption provision for both types of bonds, it is advantageous to gradually redeem both options at the end of period 3 to avoid interest payments resulting from  $i = 5\%$  and  $h = 4\%$  unless the account balance beyond period 3 is needed to fund other corporate investments. corporate earnings are available for repurchasing the bonds at end of period 3, the required repayment for coupon bond after redeeming the last coupon at the end of period 3 is simply \$2.625 million. In the case of the uniform payment bond, the required payment after the last uniform payment at the end of period 3 is obtained from Equation (7-13) as:

$$R_3 = (0.324)(P|U, 5\%, 7) = (0.324)(5.7864) = \$1.875 \text{ million.}$$

**TABLE 7-3** Example of Two Borrowing Cash Flows (in \$ thousands)

Period	Operating Cash Flow	Coupon Cash Flow	Account Balance	Uniform Cash Flow	Account Balance
0	-	\$2,375	\$2,375	\$2,375	\$2,375
1	- \$800	- 125	1,545	- 324	1,346
2	-700	- 125	782	- 324	376
3	-60	- 125	628	- 324	8
4	400	- 125	928	- 324	84
5	600	- 125	1,440	- 324	364
6	800	- 125	2,173	- 324	854
7	1,000	- 125	3,135	- 324	1,565
8	1,000	- 125	4,135	- 324	2,304
9	1,000	- 125	5,176	- 324	3,072
10	1,000	- 2,625	3,758	- 324	3,871

**Example 7-7: Provision of Reserve Funds**

Typical borrowing agreements may include various required reserve funds. [2] Consider an eighteen month project costing five million dollars. To finance this facility, coupon bonds will be issued to generate revenues which must be sufficient to pay interest charges during the eighteen months of construction, to cover all construction costs, to pay issuance expenses, and to maintain a debt service reserve fund. The reserve fund is introduced to assure bondholders of payments in case of unanticipated construction problems. It is estimated that a total amount of \$7.4 million of bond proceeds is required, including a two percent discount to underwriters and an issuance expense of \$100,000.

Three interest bearing accounts are established with the bond proceeds to separate various categories of funds:

- A construction fund to provide payments to contractors, with an initial balance of \$4,721,600. Including interest earnings, this fund will be sufficient to cover the \$5,000,000 in construction expenses.
- A capitalized interest fund to provide interest payments during the construction period. /li>
- A debt service reserve fund to be used for retiring outstanding debts after the completion of construction.

The total sources of funds (including interest from account balances) and uses of funds are summarized in Table 7-4

**TABLE 7-4** Illustrative Sources and Uses of Funds from Revenue Bonds During Construction

Sources of Funds	
Bond Proceeds	\$7,400,000
Interest Earnings on Construction Fund	278,400
Interest Earnings of Capitalized Interest Fund	77,600
Interest Earnings on Debt Service Reserve Fund	287,640
<b>Total Sources of Funds</b>	<b>\$8,043,640</b>
Uses of Funds	
Construction Costs	\$5,000,000
Interest Payments	904,100
Debt Service Reserve Fund	1,891,540
Bond Discount (2.0%)	148,000
Issuance Expense	100,000
<b>Total Uses of Funds</b>	<b>\$8,043,640</b>

**Example 7-8: Variable rate revenue bonds prospectus**

The information in Table 7-5 is abstracted from the Prospectus for a new issue of revenue bonds for the Atwood City. This prospectus language is typical for municipal bonds. Notice the provision for variable rate after the initial interest periods. The borrower reserves the right to repurchase the bond before the date for conversion to variable rate takes effect in order to protect itself from declining market interest rates in the future so that the borrower can obtain other financing arrangements at lower rates.

**TABLE 7-5** Provision of Variable Rate for Bonds

First series of 1987: \$12,000,000	
Date: December 1, 1987	Due: November 1, 2017
<p>The Bonds will be issued as fully registered bonds in the denomination of \$5,000 or any multiple thereof. Principal or redemption price of the bonds will be payable upon surrender thereof. Interest on the Bonds will be payable on May 1, 1988, and semi-annually thereafter on November 1 and May 1 by check mailed to the Bondowners registered on the State Authority's books on the Record Date. The proceeds of the Bonds will be loaned to Atwood City under a loan agreement, dated as of November 1, 1987 between the State Authority and Gerald Bank as Trustee and Paying Agent. The Bonds will bear interest at a semi-annual fixed rate of 4% for the initial interest periods from December 1, 1987 through April 1, 1990, after which the Bonds may be converted to semi-annual variable mode at the option of Atwood City upon proper notice. If the bonds are so converted, such Bonds must be tendered for mandatory purchase at par, plus 1/8th of 1% of principal amount under certain circumstances and accrued interest to the Purchase Date (unless the Bondowner files a Non-tender</p>	

Election). To be so purchased, Bonds must be delivered, accompanied by a notice of election to tender the Bonds, to the Paying Agent between the opening of business on the first day of the month preceding the effective rate date of the Bonds and 4:00 pm New York City time on the fifteenth day preceding such effective rate date for the Bonds.

[Back to top](#)

## 7.5 Overdraft Accounts

Overdrafts can be arranged with a banking institution to allow accounts to have either a positive or a negative balance. With a positive balance, interest is paid on the account balance, whereas a negative balance incurs interest charges. Usually, an overdraft account will have a maximum overdraft limit imposed. Also, the interest rate  $h$  available on positive balances is less than the interest rate  $i$  charged for borrowing.

Clearly, the effects of overdraft financing depends upon the pattern of cash flows over time. Suppose that the net cash flow for period  $t$  in the account is denoted by  $A_t$  which is the difference between the receipt  $P_t$  and the payment  $E_t$  in period  $t$ . Hence,  $A_t$  can either be positive or negative. The amount of overdraft at the end of period  $t$  is the cumulative net cash flow  $N_t$  which may also be positive or negative. If  $N_t$  is positive, a surplus is indicated and the subsequent interest would be paid to the borrower. Most often,  $N_t$  is negative during the early time periods of a project and becomes positive in the later periods when the borrower has received payments exceeding expenses.

If the borrower uses overdraft financing and pays the interest per period on the accumulated overdraft at a borrowing rate  $i$  in each period, then the interest per period for the accumulated overdraft  $N_{t-1}$  from the previous period ( $t-1$ ) is  $I_t = iN_{t-1}$  where  $I_t$  would be negative for a negative account balance  $N_{t-1}$ . For a positive account balance, the interest received is  $I_t = hN_{t-1}$  where  $I_t$  would be positive for a positive account balance.

The account balance  $N_t$  at each period  $t$  is the sum of receipts  $P_t$ , payments  $E_t$ , interest  $I_t$  and the account balance from the previous period  $N_{t-1}$ . Thus,

$$(7.15) \quad N_t = N_{t-1} + I_t + P_t - E_t$$

where  $I_t = iN_{t-1}$  for a negative  $N_{t-1}$  and  $I_t = hN_{t-1}$  for a positive  $N_{t-1}$ . The net cash flow  $A_t = P_t - E_t$  is positive for a net receipt and negative for a net payment. This equation is approximate in that the interest might be earned on intermediate balances based on the pattern of payments during the period instead of at the end of a period. The account balance in each period is of interest because there will always be a maximum limit on the amount of overdraft available.

For the purpose of separating project finances with other receipts and payments in an organization, it is convenient to establish a *credit* account into which receipts related to the project must be deposited when they are received, and all payments related to the project will be withdrawn from this account when they are needed. Since receipts typically lag behind payments for a project, this credit account will have a negative balance until such time when the receipts plus accrued interests are equal to or exceed payments in the period. When that happens, any surplus will not be deposited in the credit account, and the account is then closed with a zero balance. In that case, for negative  $N_{t-1}$ , Eq. (7.15) can be expressed as:

$$(7.16) \quad N_t = (1 + i)N_{t-1} + A_t$$

and as soon as  $N_t$  reaches a positive value or zero, the account is closed.

### Example 7-9: Overdraft Financing with Grants to a Local Agency

A public project which costs \$61,525,000 is funded eighty percent by a federal grant and twenty percent from a state grant. The anticipated duration of the project is six years with receipts from grant funds allocated at the end of each year to a local agency to cover partial payments to contractors for that year while the remaining payments to contractors will be allocated at the end of the sixth year. The end-of-year payments are given in Table 7-6 in which  $t=0$  refers to the beginning of the project, and each period is one year.

If this project is financed with an overdraft at an annual interest rate  $i = 10\%$ , then the account balance are computed by Eq. (7.15) and the results are shown in Table 7-6.

In this project, the total grant funds to the local agency covered the cost of construction in the sense that the sum of receipts equaled the sum of construction payments of \$61,525,000. However, the timing of receipts lagged payments, and the agency incurred a substantial financing cost, equal in this plan to the overdraft amount of \$1,780,000 at the end of year 6 which must be paid to close the credit account. Clearly, this financing problem would be a significant concern to the local agency.

**TABLE 7-6** Illustrative Payments, Receipts and Overdrafts for a Six Year Project

Period $t$	Receipts $P_t$	Payments $E_t$	Interest $I_t$	Account $N_t$
0	0	0	0	0
1	\$5.826	\$6.473	0	-\$0.647
2	8.401	9.334	-\$0.065	- 1.645
3	12.013	13.348	- 0.165	- 3.145
4	15.149	16.832	- 0.315	- 5.143
5	13.984	15.538	- 0.514	- 7.211
6	6.152	0	- 0.721	- 1.780
Total	\$61.525	\$61.525	-\$1.780	

**Example 7-10: Use of overdraft financing for a facility**

A corporation is contemplating an investment in a facility with the following before-tax operating net cash flow (in thousands of dollars) at year ends:

Year	0	1	2	3	4	5	6	7
Cash Flow	-500	110	112	114	116	118	120	238

The MARR of the corporation before tax is 10%. The corporation will finance the facility by using \$200,000 from retained earnings and by borrowing the remaining \$300,000 through an overdraft credit account which charges 14% interest for borrowing. Is this proposed project including financing costs worthwhile?

The results of the analysis of this project is shown in Table 7-7 as follows:

$$\begin{aligned}
 N_0 &= -500 + 200 = -300 \\
 N_1 &= (1.14)(-300) + 110 = -232 \\
 N_2 &= (1.14)(-232) + 112 = -152.48 \\
 N_3 &= (1.14)(-152.48) + 114 = -59.827 \\
 N_4 &= (1.14)(-59.827) + 116 = +47.797
 \end{aligned}$$

Since  $N_4$  is positive, it is revised to exclude the net receipt of 116 for this period. Then, the revised value for the last balance is

$$N_4' = N_4 - 116 = -68.203$$

The financial cash flow  $\bar{A}_t$  resulting from using overdrafts and making repayments from project receipts will be:

$$\begin{aligned}
 \bar{A}_0 &= -N_0 = 300 \\
 \bar{A}_1 &= -A_1 = -110 \\
 \bar{A}_2 &= -A_2 = -112 \\
 \bar{A}_3 &= -A_3 = -114 \\
 \bar{A}_4 &= N_4 - A_4 = -68.203
 \end{aligned}$$

The adjusted net present value of the combined cash flow discounted at 15% is \$27,679 as shown in Table 7-7. Hence, the project including the financing charges is worthwhile.

**TABLE 7-7** Evaluation of Facility Financing Using Overdraft (in \$ thousands)

End of Year $t$	Operating Cash Flow $A_t$	Overdraft Balance $N_t$	Financing Cash Flow $\bar{A}_t$	Combined Cash Flow $\Delta A_t$
0	- \$500		&300	- \$200
1	110	- \$300	- 110	0
2	112	- 232	- 112	0
3	114	- 152.480	- 114	0
4	116	-59.827	- 68.203	47.797
5	118	0	0	118
6	120	0	0	120
7	122	0	0	122
[PV] <sub>15%</sub>	\$21.971	0	\$5.708	\$27.679

[Back on top](#)

## 7.6 Refinancing of Debts

Refinancing of debts has two major advantages for an owner. First, they allow re-financing at intermediate stages to save interest charges. If a borrowing agreement is made during a period of relatively high interest charges, then a repurchase agreement allows the borrower to re-finance at a lower interest rate. Whenever the borrowing interest rate declines such that the savings in interest payments will cover any transaction expenses (for purchasing outstanding notes or bonds and arranging new financing), then it is advantageous to do so.

Another reason to repurchase bonds is to permit changes in the operation of a facility or new investments. Under the terms of many bond agreements, there may be restrictions on the use of revenues from a particular facility while any bonds are outstanding. These restrictions are inserted to insure bondholders that debts will be repaid. By repurchasing bonds, these restrictions are removed. For example, several bridge authorities had bonds that restricted any diversion of toll revenues to other transportation services such as transit. By repurchasing these bonds, the authority could undertake new operations. This type of repurchase may occur voluntarily even without a repurchase agreement in the original bond. The borrower may give bondholders a premium to retire bonds early.

### Example 7-11: Refinancing a loan.

Suppose that the bank loan shown in Example 7-4 had a provision permitting the borrower to repay the loan without penalty at any time. Further,

suppose that interest rates for new loans dropped to nine percent at the end of year six of the loan. Issuing costs for a new loan would be \$50,000. Would it be advantageous to re-finance the loan at that time?

To repay the original loan at the end of year six would require a payment of the remaining principal plus the interest due at the end of year six. This amount  $R_6$  is equal to the present value of remaining fourteen payments discounted at the loan interest rate 11.2% to the end of year 6 as given in Equation (7-13) as follows:

$$R_6 = \sum_{t=1}^{14} \frac{\$1.324 \text{ million}}{(1.112)^t} = \$9.152 \text{ million}$$

The new loan would be in the amount of \$ 9.152 million plus the issuing cost of \$0.05 million for a total of \$ 9.202 million. Based on the new loan interest rate of 9%, the new uniform annual payment on this loan from years 7 to 20 would be:

$$U^1 = (\$9.202 \text{ million})(U|P, 9\%, 14) = \$1.182 \text{ million}$$

The net present value of the financial cash flow for the new loan would be obtained by discounting at the corporate MARR of 15% to the end of year six as follows:

$$FPV = \sum_{t=1}^{14} \frac{\$1.182 \text{ million}}{(1.15)^t} = \$6.766 \text{ million}$$

Since the annual payment on the new loan is less than the existing loan (\$1.182 versus \$1.324 million), the new loan is preferable.

[Back to top](#)

## 7.7 Project versus Corporate Finance

We have focused so far on problems and concerns at the project level. While this is the appropriate viewpoint for project managers, it is always worth bearing in mind that projects must fit into broader organizational decisions and structures. This is particularly true for the problem of project finance, since it is often the case that financing is planned on a corporate or agency level, rather than a project level. Accordingly, project managers should be aware of the concerns at this level of decision making.

A construction project is only a portion of the general capital budgeting problem faced by an owner. Unless the project is very large in scope relative to the owner, a particular construction project is only a small portion of the capital budgeting problem. Numerous construction projects may be lumped together as a single category in the allocation of investment funds. Construction projects would compete for attention with equipment purchases or other investments in a private corporation.

Financing is usually performed at the corporate level using a mixture of long term corporate debt and retained earnings. A typical set of corporate debt instruments would include the different bonds and notes discussed in this chapter. Variations would typically include different maturity dates, different levels of security interests, different currency denominations, and, of course, different interest rates.

Grouping projects together for financing influences the type of financing that might be obtained. As noted earlier, small and large projects usually involve different institutional arrangements and financing arrangements. For small projects, the fixed costs of undertaking particular kinds of financing may be prohibitively expensive. For example, municipal bonds require fixed costs associated with printing and preparation that do not vary significantly with the size of the issue. By combining numerous small construction projects, different financing arrangements become more practical.

While individual projects may not be considered at the corporate finance level, the problems and analysis procedures described earlier are directly relevant to financial planning for groups of projects and other investments. Thus, the net present values of different financing arrangements can be computed and compared. Since the net present values of different sub-sets of either investments or financing alternatives are additive, each project or finance alternative can be disaggregated for closer attention or aggregated to provide information at a higher decision making level.

### Example 7-12: Basic types of repayment schedules for loans.

Coupon bonds are used to obtain loans which involve no payment of principal until the maturity date. By combining loans of different maturities, however, it is possible to achieve almost any pattern of principal repayments. However, the interest rates charged on loans of different maturities will reflect market forces such as forecasts of how interest rates will vary over time. As an example, Table 7-8 illustrates the cash flows of debt service for a series of coupon bonds used to fund a municipal construction project; for simplicity not all years of payments are shown in the table.

In this financing plan, a series of coupon bonds were sold with maturity dates ranging from June 1988 to June 2012. Coupon interest payments on all outstanding bonds were to be paid every six months, on December 1 and June 1 of each year. The interest rate or "coupon rate" was larger on bonds with longer maturities, reflecting an assumption that inflation would increase during this period. The total principal obtained for construction was \$26,250,000 from sale of these bonds. This amount represented the gross sale amount before subtracting issuing costs or any sales discounts; the amount available to support construction would be lower. The maturity dates for bonds were selected to require relative high repayment amounts until December 1995, with a declining repayment amount subsequently. By shifting the maturity dates and amounts of bonds, this pattern of repayments could be altered. The initial interest payment (of \$819,760 on December 1, 1987), reflected a payment for only a portion of a six month period since the bonds were issued in late June of 1987.

**TABLE 7-8** Illustration of a Twenty-five Year Maturity Schedule for Bonds

Date	Maturing Principal	Corresponding Interest Rate	Interest Due	Annual Debt Service
Dec. 1, 1987			\$819,760	\$819,760
June 1, 1988	\$1,350,000	5.00%	894,429	
Dec. 1, 1988			860,540	3,104,969
June 1, 1989	1,450,000	5.25	860,540	
Dec. 1, 1989			822,480	3,133,020
June 1, 1990	1,550,000	5.50	822,480	
Dec. 1, 1990			779,850	3,152,330
June 1, 1991	1,600,000	5.80	779,850	
Dec. 1, 1991			733,450	3,113,300
June 1, 1992	1,700,000	6.00	733,450	
Dec. 1, 1992			682,450	3,115,900
June 1, 1993	1,800,000	6.20	682,450	
Dec. 1, 1993			626,650	3,109,100
.	.	.	.	.
.	.	.	.	.
.	.	.	.	.
June 1, 2011	880,000	8.00	68,000	
Dec. 1, 2011			36,000	984,000
June 1, 2012	96,000	8.00	36,000	
Dec. 1, 2012				996,000

[Back to top](#)

## 7.8 Shifting Financial Burdens

The different participants in the construction process have quite distinct perspectives on financing. In the realm of project finance, the revenues to one participant represent an expenditure to some other participant. Payment delays from one participant result in a financial burden and a cash flow problem to other participants. It is common occurrence in construction to reduce financing costs by delaying payments in just this fashion. Shifting payment times does not eliminate financing costs, however, since the financial burden still exists.

Traditionally, many organizations have used payment delays both to shift financing expenses to others or to overcome momentary shortfalls in financial resources. From the owner's perspective, this policy may have short term benefits, but it certainly has long term costs. Since contractors do not have large capital assets, they typically do not have large amounts of credit available to cover payment delays. Contractors are also perceived as credit risks in many cases, so loans often require a premium interest charge. Contractors faced with large financing problems are likely to add premiums to bids or not bid at all on particular work. For example, A. Maevis noted: [\[3\]](#)

...there were days in New York City when city agencies had trouble attracting bidders; yet contractors were beating on the door to get work from Consolidated Edison, the local utility. Why? First, the city was a notoriously slow payer, COs (change orders) years behind, decision process chaotic, and payments made 60 days after close of estimate. Con Edison paid on the 20th of the month for work done to the first of the month. Change orders negotiated and paid within 30 days-60 days. If a decision was needed, it came in 10 days. The number of bids you receive on your projects are one measure of your administrative efficiency. Further, competition is bound to give you the lowest possible construction price.

Even after bids are received and contracts signed, delays in payments may form the basis for a successful claim against an agency on the part of the contractor.

The owner of a constructed facility usually has a better credit rating and can secure loans at a lower borrowing rate, but there are some notable exceptions to this rule, particularly for construction projects in developing countries. Under certain circumstances, it is advisable for the owner to advance periodic payments to the contractor in return for some concession in the contract price. This is particularly true for large-scale construction projects with long durations for which financing costs and capital requirements are high. If the owner is willing to advance these amounts to the contractor, the gain in lower financing costs can be shared by both parties through prior agreement.

Unfortunately, the choice of financing during the construction period is often left to the contractor who cannot take advantage of all available options alone. The owner is often shielded from participation through the traditional method of price quotation for construction contracts. This practice merely exacerbates the problem by excluding the owner from participating in decisions which may reduce the cost of the project.

Under conditions of economic uncertainty, a premium to hedge the risk must be added to the estimation of construction cost by both the owner and the contractor. The larger and longer the project is, the greater is the risk. For an unsophisticated owner who tries to avoid all risks and to place the financing burdens of construction on the contractor, the contract prices for construction facilities are likely to be increased to reflect the risk premium charged by the contractors. In dealing with small projects with short durations, this practice may be acceptable particularly when the owner lacks any expertise to evaluate the project financing alternatives or the financial stability to adopt innovative financing schemes. However, for large scale projects of long duration, the owner cannot escape the responsibility of participation if it wants to avoid catastrophes of run-away costs and expensive litigation. The construction of nuclear power plants in the private sector and the construction of transportation facilities in the public sector offer ample examples of such problems. If the responsibilities of risk sharing among various parties in a construction project can be clearly defined in the planning stage, all parties can be benefited to take advantage of cost saving and early use of the constructed facility.

### Example 7-13: Effects of payment delays

Table 7-9 shows an example of the effects of payment timing on the general contractor and subcontractors. The total contract price for this project is \$5,100,000 with scheduled payments from the owner shown in Column 2. The general contractor's expenses in each period over the lifetime of the project are given in Column 3 while the subcontractor's expenses are shown in Column 4. If the general contractor must pay the subcontractor's expenses as well as its own at the end of each period, the net cash flow of the general contractor is obtained in Column 5, and its cumulative cash flow in Column 6.

**TABLE 7-9** An Example of the Effects of Payment Timing

Period	Owner Payments	General Contractor's Expenses	Subcontractor's Expenses	General Contractor's Net Cash Flow	Cumulative Cash Flow
1	---	\$100,000	\$900,000	- \$1,000,000	- \$1,000,000
2	\$950,000	100,000	900,000	- 50,000	- 1,050,000
3	950,000	100,000	900,000	- 50,000	- 1,100,000
4	950,000	100,000	900,000	- 50,000	- 1,150,000
5	950,000	100,000	900,000	- 50,000	- 1,200,000
6	<u>1,300,000</u>	-	-	<u>1,300,000</u>	100,000
Total	\$5,100,000	\$500,000	\$4,500,000	\$100,000	

Note: Cumulative cash flow includes no financing charges.

In this example, the owner withholds a five percent retainage on cost as well as a payment of \$100,000 until the completion of the project. This \$100,000 is equal to the expected gross profit of the contractor without considering financing costs or cash flow discounting. Processing time and contractual agreements with the owner result in a delay of one period in receiving payments. The actual construction expenses from the viewpoint of the general contractor consist of \$100,000 in each construction period plus payments due to subcontractors of \$900,000 in each period. While the net cash flow without regard to discounting or financing is equal to a \$100,000 profit for the general contractor, financial costs are likely to be substantial. With immediate payment to subcontractors, over \$1,000,000 must be financed by the contractor throughout the duration of the project. If the general contractor uses borrowing to finance its expenses, a maximum borrowing amount of \$1,200,000 in period five is required even without considering intermediate interest charges. Financing this amount is likely to be quite expensive and may easily exceed the expected project profit.

By delaying payments to subcontractors, the general contractor can substantially reduce its financing requirement. For example, Table 7-10 shows the resulting cash flows from delaying payments to subcontractors for one period and for two periods, respectively. With a one period delay, a maximum amount of \$300,000 (plus intermediate interest charges) would have to be financed by the general contractor. That is, from the data in Table 7-10, the net cash flow in period 1 is -\$100,000, and the net cash flow for each of the periods 2 through 5 is given by:

$$\$950,000 - \$100,000 - \$900,000 = -\$50,000$$

Finally, the net cash flow for period 6 is:

$$\$1,300,000 - \$900,000 = \$400,000$$

Thus, the cumulative net cash flow from periods 1 through 5 as shown in Column 2 of Table 7-10 results in maximum shortfall of \$300,000 in period 5 in Column 3. For the case of a two period payment delay to the subcontractors, the general contractor even runs a positive balance during construction as shown in Column 5. The positive balance results from the receipt of owner payments prior to reimbursing the subcontractor's expenses. This positive balance can be placed in an interest bearing account to earn additional revenues for the general contractor. Needless to say, however, these payment delays mean extra costs and financing problems to the subcontractors. With a two period delay in payments from the general contractor, the subcontractors have an unpaid balance of \$1,800,000, which would represent a considerable financial cost.

**TABLE 7-10** An Example of the Cash Flow Effects of Delayed Payments

Period	One Period Payment Delay		Two Period Payment Delay	
	Net Cash Flow	Cumulative Cash Flow	Net Cash Flow	Cumulative Cash Flow
1	- \$100,000	- \$100,000	- \$100,000	- \$100,000
2	- 50,000	- 150,000	850,000	750,000
3	- 50,000	- 200,000	- 50,000	700,000
4	- 50,000	- 250,000	- 50,000	650,000
5	- 50,000	- 300,000	- 50,000	600,000
6	400,000	100,000	400,000	1,000,000
7			- 900,000	100,000

[Back to top](#)

## 7.9 Construction Financing for Contractors

For a general contractor or subcontractor, the cash flow profile of expenses and incomes for a construction project typically follows the work in progress for which the contractor will be paid periodically. The markup by the contractor above the estimated expenses is included in the total contract price and the terms of most contracts generally call for monthly reimbursements of work completed less retainage. At time period 0, which denotes the beginning of the construction contract, a considerable sum may have been spent in preparation. The contractor's expenses which occur more or less continuously for the project duration are depicted by a piecewise continuous curve while the receipts (such as progress payments from the owner) are represented by a step function as shown in Fig. 7-1. The owner's payments for the work completed are assumed to lag one period behind expenses except that a withholding proportion or remainder is paid at the end of construction. This method of analysis is applicable to realistic situations where a time period is represented by one month and the number of time periods is extended to cover delayed receipts as a result of retainage.

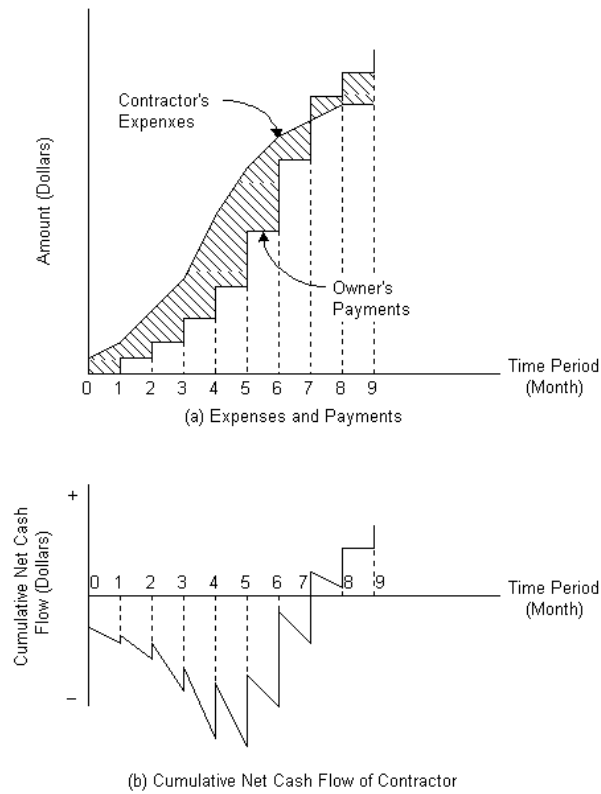

**Figure 7-1** Contractor's Expenses and Owner's Payments

While the cash flow profiles of expenses and receipts are expected to vary for different projects, the characteristics of the curves depicted in Fig. 7-1 are sufficiently general for most cases. Let  $E_t$  represent the contractor's expenses in period  $t$ , and  $P_t$  represent owner's payments in period  $t$ , for  $t=0,1,2,\dots,n$  for  $n=5$  in this case. The net operating cash flow at the end of period  $t$  for  $t \geq 0$  is given by:

$$(7.17) \quad A_t = P_t - E_t$$

where  $A_t$  is positive for a surplus and negative for a shortfall.

The cumulative operating cash flow at the end of period  $t$  just before receiving payment  $P_t$  (for  $t \geq 1$ ) is:

$$(7.18) \quad F_t = N_{t-1} - E_t$$

where  $N_{t-1}$  is the cumulative net cash flows from period 0 to period  $(t-1)$ . Furthermore, the cumulative net operating cash flow after receiving payment  $P_t$  at the end of period  $t$  (for  $t \geq 1$ ) is:

$$(7.19) \quad N_t = F_t + P_t = N_{t-1} + A_t$$

The gross operating profit  $G$  for a  $n$ -period project is defined as net operating cash flow at  $t=n$  and is given by:

$$(7.20) \quad G = \sum_{t=0}^n (P_t - E_t) = \sum_{t=0}^n A_t = N_n$$

The use of  $N_n$  as a measure of the gross operating profit has the disadvantage that it is not adjusted for the time value of money.

Since the net cash flow  $A_t$  (for  $t=0,1,\dots,n$ ) for a construction project represents the amount of cash required or accrued after the owner's payment is plowed back to the project at the end of period  $t$ , the internal rate of return (IRR) of this cash flow is often cited in the traditional literature in construction as a profit measure. To compute IRR, let the net present value (NPV) of  $A_t$  discounted at a discount rate  $i$  per period be zero, i.e.,



$$(7.21) \quad NPV = \sum_{t=0}^n A_t (1+i)^{-t} = 0$$

The resulting  $i$  (if it is unique) from the solution of Eq. (7.21) is the IRR of the net cash flow  $A_t$ . Aside from the complications that may be involved in the solution of Eq. (7.21), the resulting  $i = \text{IRR}$  has a meaning to the contractor only if the firm finances the entire project from its own equity. This is seldom if ever the case since most construction firms are highly *leveraged*, i.e. they have relatively small equity in fixed assets such as construction equipment, and depend almost entirely on borrowing in financing individual construction projects. The use of the IRR of the net cash flows as a measure of profit for the contractor is thus misleading. It does not represent even the IRR of the bank when the contractor finances the project through overdraft since the gross operating profit would not be given to the bank.

Since overdraft is the most common form of financing for small or medium size projects, we shall consider the financing costs and effects on profit of - the use of overdrafts. Let  $\bar{F}_t$  be the cumulative cash flow before the owner's payment in period  $t$  including interest and  $\bar{N}_t$  be the cumulative net cash flow in period  $t$  including interest. At  $t = 0$  when there is no accrued interest,  $\bar{F}_0 = F_0$  and  $\bar{N}_0 = N_0$ . For  $t \geq 1$  in period  $t$  can be obtained by considering the contractor's expenses  $E_t$  to be dispersed uniformly during the period.

The inclusion of interest on contractor's expenses  $E_t$  during period  $t$  (for  $G = 1$ ) is based on the rationale that the S-shaped curve depicting the contractor's expenses in Figure 7-1 is fairly typical of actual situations, where the owner's payments are typically made at the end of well defined periods. Hence, interest on expenses during period  $t$  is approximated by one half of the amount as if the expenses were paid at the beginning of the period. In fact,  $E_t$  is the accumulation of all expenses in period  $t$  and is treated - as an expense at the end of the period. Thus, the interest per period  $\bar{I}_t$  (for  $t \geq 1$ ) is the combination of interest charge for  $N_{t-1}$  in period  $t$  and that for one half of  $E_t$  in the same period  $t$ . If  $\bar{N}_t$  is negative and  $i$  is the borrowing rate for the shortfall,

$$(7.22) \quad \bar{I}_t = i\bar{N}_{t-1} - \frac{iE_t}{2}$$

If  $\bar{N}_t$  is positive and  $h$  is the investment rate for the surplus,

$$(7.23) \quad \bar{I}_t = h\bar{N}_{t-1} - \frac{iE_t}{2}$$

Hence, if the cumulative net cash flow  $\bar{N}_t$  is negative, the interest on the overdraft for each period  $t$  is paid by the contractor at the end of each period. If  $N_t$  is positive, a surplus is indicated and the subsequent interest would be paid to the contractor. Most often,  $N_t$  is negative during the early time periods of a project and becomes positive in the later periods when the contractor has received payments exceeding expenses.

Including the interest accrued in period  $t$ , the cumulative cash flow at the end of period  $t$  just before receiving payment  $P_t$  (for  $t \geq 1$ ) is:

$$(7.24) \quad \bar{F}_t = \bar{N}_{t-1} + \bar{I}_t - E_t$$

Furthermore, the cumulative net cash flow after receiving payment  $P_t$  at the end of period  $t$  (for  $t \geq 1$ ) is:

$$(7.25) \quad \bar{N}_t = \bar{F}_t + P_t = \bar{N}_{t-1} + \bar{I}_t - E_t + P_t$$

The gross operating profit  $\bar{G}$  at the end of a  $n$ -period project including interest charges is:

$$(7.26) \quad \bar{G} = \bar{N}_n$$

where  $\bar{N}_n$  is the cumulative net cash flow for  $t = n$ .

#### Example 7-14: Contractor's gross profit from a project

The contractor's expenses and owner's payments for a multi-year construction project are given in Columns 2 and 3, respectively, of Table 7-11. Each time period is represented by one year, and the annual interest rate  $i$  is for borrowing 11%. The computation has been carried out in Table 7-

11, and the contractor's gross profit  $G$  is found to be  $N_5 = \$8.025$  million in the last column of the table.

**TABLE 7-11** Example of Contractor's Expenses and Owner's Payments (\$ Million)

Period $t$	Contractor's Expenses $E_t$	Owner's Payments $P_t$	Net Cash Flow $A_t$	Cumulative Cash Before Payments $F_t$	Cumulative Net Cash $N_t$
0	\$3.782	\$0	-\$3.782	-\$3.782	-\$3.782
1	7.458	6.473	-0.985	-11.240	-4.767
2	10.425	9.334	-1.091	-15.192	-5.858
3	14.736	13.348	-1.388	-20.594	-7.246
4	11.420	16.832	+5.412	-18.666	-1.834
5	5.679	15.538	+9.859	-7.513	+8.025
Total	\$53.500	\$61.525	+\$8.025		

**Example 7-15: Effects of Construction Financing**

The computation of the cumulative cash flows including interest charges at  $i = 11\%$  for Example 7-14 is shown in Table 7-12 with gross profit  $\bar{G} = \bar{N}_5 = \$1.384$  million. The results of computation are also shown in Figure 7-2.

**TABLE 7-12** Example Cumulative Cash Flows Including Interests for a Contractor (\$ Million)

Period (year) $t$	Construction Expenses $E_t$	Owner's Payments $P_t$	Annual Interest $\bar{I}_t$	Cumulative Before Payments $\bar{F}_t$	Cumulative Net Cash Flow $\bar{N}_t$
0	\$3.782	0	0	-\$3.782	-\$3.782
1	7.458	\$6.473	-\$0.826	-12.066	-5.593
2	10.425	9.334	-1.188	-17.206	-7.872
3	14.736	13.348	-1.676	-24.284	-10.936
4	11.420	16.832	-1.831	-24.187	-7.354
5	5.679	15.538	-1.121	-14.154	+1.384

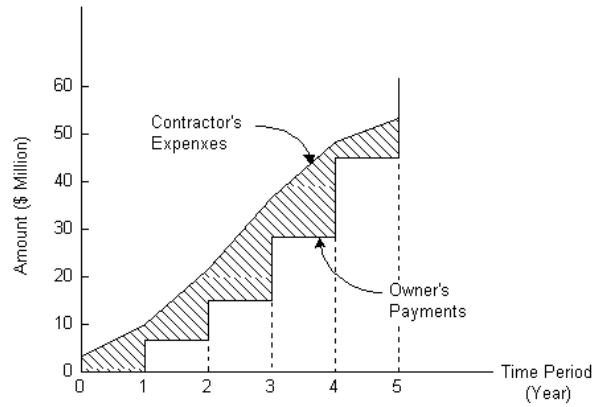

(a) Expenses and Payments

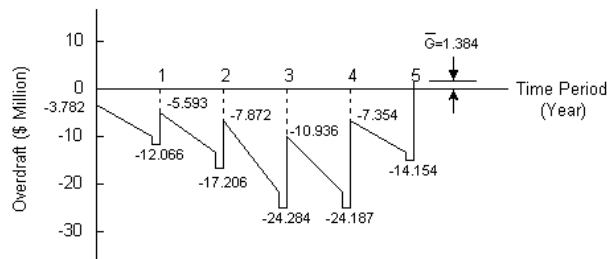

(b) Overdraft Including Interest Charges

**Figure 7-2** Effects of Overdraft Financing

[Back to top](#)

## 7.10 Effects of Other Factors on a Contractor's Profits

In times of economic uncertainty, the fluctuations in inflation rates and market interest rates affect profits significantly. The total contract price is usually a composite of expenses and payments in then-current dollars at different payment periods. In this case, estimated expenses are also expressed in then-current dollars.

During periods of high inflation, the contractor's profits are particularly vulnerable to delays caused by uncontrollable events for which the owner will not be responsible. Hence, the owner's payments will not be changed while the contractor's expenses will increase with inflation.

### Example 7-16: Effects of Inflation

Suppose that both expenses and receipts for the construction project in the Example 7-14 are now expressed in then-current dollars (with annual inflation rate of 4%) in Table 7-13. The market interest rate reflecting this inflation is now 15%. In considering these expenses and receipts in then-current dollars and using an interest rate of 15% including inflation, we can recompute the cumulative net cash flow (with interest). Thus, the gross profit less financing costs becomes  $\bar{C} = \bar{N}_5 = \$0.4$  million. There will be a loss rather than a profit after deducting financing costs and adjusting for the effects of inflation with this project.

**TABLE 7-13** Example of Overdraft Financing Based on Inflated Dollars (\$ Million)

Period (year) $t$	Construction Expenses $E_t$	Owner's Payments $P_t$	Annual Interest $\bar{I}_t$	Cumulative Before Payments $\bar{F}_t$	Cumulative Net Cash Flow $\bar{N}_t$
0	\$3.782	0	0	-\$3.782	-\$3.782
1	7.756	\$6.732	-\$1.149	-12.687	-5.955
2	11.276	10.096	-1.739	-18.970	-8.874
3	16.576	15.015	-2.574	-28.024	-13.009
4	13.360	16.691	-2.953	-29.322	-9.631
5	6.909	18.904	-1.964	-18.504	+0.400

### Example 7-17: Effects of Work Stoppage at Periods of Inflation

Suppose further that besides the inflation rate of 4%, the project in Example 7-16 is suspended at the end of year 2 due to a labor strike and resumed after one year. Also, assume that while the contractor will incur higher interest expenses due to the work stoppage, the owner will not increase the payments to the contractor. The cumulative net cash flows for the cases of operation and financing expenses are recomputed and tabulated in Table 7-14. The construction expenses and receipts in then-current dollars resulting from the work stopping and the corresponding net cash flow of the project including financing (with annual interest accumulated in the overdraft to the end of the project) is shown in Fig. 7-3. It is noteworthy that, with or without the work stoppage, the gross operating profit declines in value at the end of the project as a result of inflation, but with the work stoppage it has eroded - further to a loss of \$3.524 million as indicated by  $\bar{N}_6 = -3.524$  in Table 7-14.

**TABLE 7-14** Example of the Effects of Work Stoppage and Inflation on a Contractor (\$ Million)

Period (year) $t$	Construction Expenses $E_t$	Owner's Payments $P_t$	Annual Interest $\bar{I}_t$	Cumulative Before Payments $\bar{F}_t$	Cumulative Net Cash Flow $\bar{N}_t$
0	\$3.782	0	0	-\$3.782	-\$3.782
1	7.756	\$6.732	-\$1.149	-12.687	-5.955
2	11.276	10.096	-1.739	-18.970	-8.874
3	0	0	-1.331	-10.205	-10.205
4	17.239	15.015	-2.824	-30.268	-15.253
5	13.894	16.691	-3.330	-32.477	-12.786
6	7.185	18.904	-2.457	22.428	-3.524

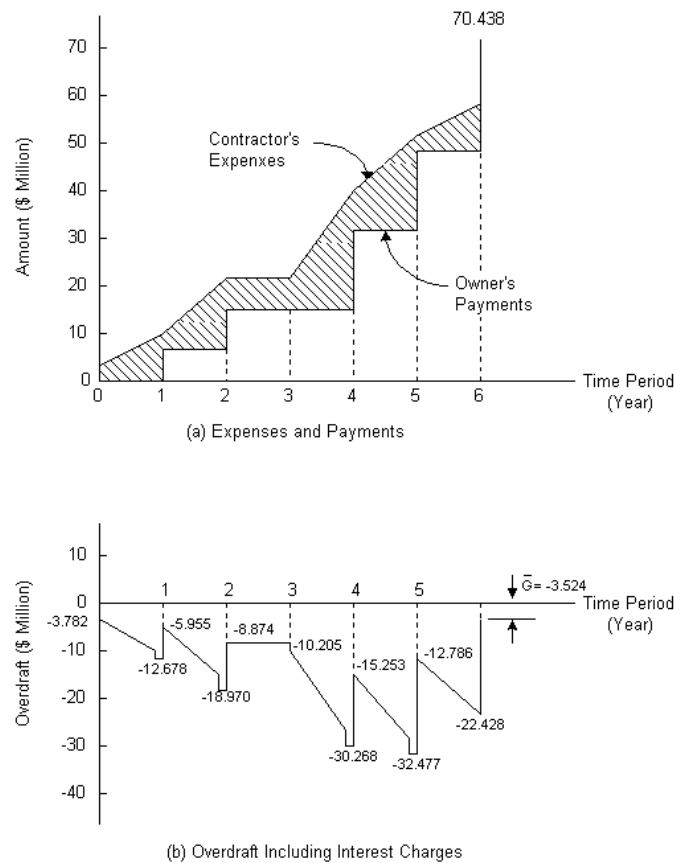

**Figure 7-3** Effects of Inflation and Work Stoppage

**Example 7-18: Exchange Rate Fluctuation.** Contracting firms engaged in international practice also face financial issues associated with exchange rate fluctuations. Firms are typically paid in local currencies, and the local currency may lose value relative to the contractor's home currency. Moreover, a construction contractor may have to purchase component parts in the home currency. Various strategies can be used to reduce this exchange rate risk, including:

- Pooling expenses and incomes from multiple projects to reduce the amount of currency exchanged.
- Purchasing futures contracts to exchange currency at a future date at a guaranteed rate. If the exchange rate does not change or changes in a favorable direction, the contractor may decide not to exercise or use the futures contract.
- Borrowing funds in local currencies and immediately exchanging the expected profit, with the borrowing paid by eventual payments from the owner.

[Back to top](#)

## 7.11 References

1. Au, T., and C. Hendrickson, "Profit Measures for Construction Projects," *ASCE Journal of Construction Engineering and Management*, Vol. 112, No. CO-2, 1986, pp. 273-286.
2. Brealey, R. and S. Myers, *Principles of Corporate Finance*, McGraw-Hill, Sixth Edition, 2002.
3. Collier, C.A. and D.A. Halperin, *Construction Funding: Where the Money Comes From*, Second Edition, John Wiley and Sons, New York, 1984.
4. Dipasquale, D. and C. Hendrickson, "Options for Financing a Regional Transit Authority," *Transportation Research Record*, No. 858, 1982, pp. 29-35.
5. Kapila, Prashant and Chris Hendrickson, "Exchange Rate Risk Management in International Construction Ventures," *ASCE J. of Construction Eng. and Mgmt*, 17(4), October 2001.
6. Goss, C.A., "Financing: The Contractor's Perspective," *Construction Contracting*, Vol. 62, No. 10, pp. 15-17, 1980.

[Back to top](#)

## 7.12 Problems

1. Compute the effective annual interest rate with a nominal annual rate of 12% and compounding periods of:
  1. monthly,
  2. quarterly, and
  3. semi-annually (i.e. twice a year).
2. A corporation is contemplating investment in a facility with the following before-tax operating cash flow (in thousands of constant dollars) at year ends:

Year	0	1	2	3	4	5	6	7
Cash	-	\$110	\$112	\$114	\$116	\$118	\$120	\$122
Flow	\$500							

The MARR of the corporation before tax is 10%. The corporation will finance the facility by using \$200,000 from retained earning and by borrowing the remaining amount through one of the following two plans:

1. A seven year coupon bond with 5% issuance cost and 12% interest rate payable annually.
2. Overdraft from a bank at 13% interest

Which financing plan is preferable?

3. Suppose that an overseas constructor proposed to build the facility in Problem P7-2 at a cost of \$550,000 (rather than \$500,000), but would also arrange financing with a 5% issuing charge and uniform payments over a seven year period. This financing is available from an export bank with a special interest rate of 9%. Is this offer attractive?
4. The original financing arrangement to obtain a \$550,000 loan for a seven year project with 5% issuing charge is to repay both the loan and issue charge through uniform annual payments with a 9% annual interest rate over the seven year period. If this arrangement is to be refinanced after 2 years by coupon bonds which pays 8% nominal annual interest (4% per 6-month period) for the remaining 5 years at the end of which the principal will be due. Assuming an origination fee of 2%, determine the total amount of coupon bonds necessary for refinancing, and the interest payment per period.
5. A public agency is contemplating construction of a facility with the following operating cash flow (in thousands of constant dollars) at year ends.

Year	0	1	2	3	4	5
Cash Flow	-\$400	-\$200	\$280	\$300	\$320	\$340

The MARR of the agency is 10% including inflation. If the agency can financing this facility in one of the following two ways, which financing scheme is preferable?

1. Overdraft financing at an interest rate of 12% per annum.
2. Five year coupon bonds (so that all principal is repaid at the end of year 5) in the amount of \$672,000 including an issuing cost of 5% and at a 10% interest rate.

6. Suppose that the coupon bonds in Problem 5 are to be refinanced after two years by a uniform payment mortgage for the remaining three years, for an issuing cost of \$10,000 in then-current dollars. If the mortgage is repaid with uniform monthly payments for 36 months and the monthly interest rate is 1%, determine the amount of monthly payment.
7. Suppose the investment in a facility by a public agency results in a net operating cash flow at year ends (in thousands of dollars) as follows:

Year	0	1	2	3	4	5	6
Cash Flow	-\$850	-\$250	\$250	\$250	\$450	\$450	\$450

The agency has a MARR of 9% and is not subject to tax. If the project can be financed in one of the two following ways, which financing scheme is preferable?

1. Six-year uniform payment bonds at 11% interest rate for a total amount of borrowing of \$875,000 which includes \$25,000 of issuing cost.
2. Five year coupon bonds at 10% interest rate for a total amount of borrowing of \$900,000 which includes \$50,000 of issuing cost.

8. Suppose that the five year coupon bond in Problem 7 is to be refinanced, *after* the payment of interest at the end of year 3, by a uniform mortgage which requires an issuance cost of 2%. If the annual interest rate is 9%, what is the uniform annual payment on the mortgage for another 5 years.
9. A corporation plans to invest in a small project which costs a one-time expenditure of \$700,000 and offers an annual return of \$250,000 each in the next four years. It intends to finance this project by issuing a five year promissory note which requires an origination fee of \$10,000. Interest payments are made annually at 9% with the repayment of the principal at the end of five years. If the before tax MARR of the Corporation is 11%, find the adjusted net present value of the investment in conjunction with the proposed financing.
10. A local transportation agency is receiving a construction grant in annual installments from the federal and state governments for a construction project. However, it must make payments to the contractor periodically for construction expenditures. Suppose that all receipts and expenditures (in million dollars) are made at year ends as shown below. Determine the overdraft at the end of year 5 if the project is financed with an overdraft at an annual interest rate of 10%.

Year	0	1	2	3	4	5
Receipts	0	\$4.764	\$7.456	\$8.287	\$6.525	\$2.468
Expenditures	\$1.250	\$6.821	9.362	7.744	4.323	0

11. The operating cash flows of contractor's expenses and the owner's payments for a construction project as stipulated in the contract agreement are shown in Table 7-15. The contractor has established a line of credit from the bank at a monthly interest rate of 1.5%, and the contractor is allowed to borrow the shortfall between expense and receipt at the end of each month but must deposit any excess of net operating cash flow to reduce the loan amount. Assuming that there is no inflation, determine the cumulative net cash flow including interest due to overdrafting. Also find the contractor's gross profit.

**Table 7-15**

End of Month	Contractor's Expenses	Owner's Payments
0	-\$200,000	0
1	-250,000	\$225,000
2	-400,000	360,000
3	-520,000	468,000
4	-630,000	567,000
5	-780,000	702,000
6	-750,000	675,000
7	-660,000	594,000
8	-430,000	387,000

9	-380,000	342,000
10	-332,000	298,800
11	-256,000	230,400
12	-412,000	370,800
13	0	1,080,000
14	0	600,000
Total	\$6,000,000	6,900,000

12. Suppose that both contractor's expenses and owner's receipts for a construction project are expressed in then-current inflated dollars in Table 7-16. Suppose also that the monthly interest rate required by the bank is 1.5%. Suppose that the work is stopped for two months at the end of month 5 due to labor strike while the monthly inflation rate is 0.5%. Under the terms of the contract between the owner and the contractor, suppose that the owner's payments will be delayed but not adjusted for inflation. Find the cumulative net cash flow with interest due to overdrafting.

**Table 7-16**

End of Month	Contractor's Expenses	Owner's Payments
0	-\$200,000	0
1	-251,250	\$225,000
2	-404,000	360,000
3	-527,852	468,000
4	-642,726	567,000
5	-799,734	702,000
6	-772,800	675,000
7	-683,430	594,000
8	-447,501	387,000
9	-397,442	342,000
10	-348,965	298,800
11	-270,438	230,400
12	-437,420	370,800
13	0	1,080,000
14	0	600,000
Total	-\$6,183,558	6,900,000

13. The contractor's construction expenses and the owner's payments for a construction project in then-current dollars as stipulated in the contract agreement are shown in Table 7-17. The contractor has established a line of credit from the bank at a monthly interest rate of 2% (based on then-current dollars), and the contractor is allowed to borrow the shortfalls between expense and receipt at the end of each month but must deposit any excess of net operating cash flow to reduce the loan amount. Determine the cumulative net cash flow including interest due to overdrafting. Also, find the contractor's gross profit.

**Table 7-17**

End of Month	Contractor's Expenses	Owner's Payments
0	\$50,000	0
1	85,000	\$47,500
2	176,000	80,700
3	240,000	167,200
4	284,000	228,000
5	252,000	270,000
6	192,000	237,500
7	123,000	182,400
8	98,000	116,800
9	0	319,900
Total	-\$1,500,000	1,650,000

14. Suppose that both the contractor's expenses and owner's payments for a construction project are expressed in then-current dollars in Table 7-17 (Problem 13). The monthly interest rate required by the bank is 2.5% based on then-current dollars. Suppose that the work is stopped for three months at the end of month 4 due to a labor strike while the monthly inflation rate is 0.5%. The owner's payments will be delayed but not adjusted for inflation. Find the cumulative net cash flow expressed in then-current dollars, with interest compounded and accumulated to the end of the project.

[Back to top](#)

## 7.13 Footnotes

- This table is adapted from A.J. Henkel, "The Mechanics of a Revenue Bond Financing: An Overview," *Infrastructure Financing*, Kidder, Peabody & Co., New York, 1984. ([Back](#))
- The calculations for this bond issue are adapted from a hypothetical example in F. H. Fuller, "Analyzing Cash Flows for Revenue Bond Financing," *Infrastructure Financing*, Kidder, Peabody & Co., Inc., New York, 1984, pp. 37-47. ([Back](#))
- Maevis, Alfred C., "Construction Cost Control by the Owner," *ASCE Journal of the Construction Division*, Vol. 106, No. 4, December, 1980, pg. 444. ([Back](#))

[Previous Chapter](#) | [Table of Contents](#) | [Next Chapter](#)

<a href="#">Go Up to Table of Contents</a>	
<a href="#">Go To Chapter 7 (Financing of Constructed Facilities)</a>	<a href="#">Go To Chapter 9 (Construction Planning)</a>
<i>Construction Pricing and Contracting</i> <a href="#">Pricing for Constructed Facilities</a> <a href="#">Contract Provisions for Risk Allocation</a> <a href="#">Risks and Incentives on Construction</a> <a href="#">Quality</a> <a href="#">Types of Construction Contracts</a> <a href="#">Relative Costs of Construction Contracts</a> <a href="#">Principles of Competitive Bidding</a> <a href="#">Principles of Contract Negotiation</a> <a href="#">Negotiation Simulation: An Example</a> <a href="#">Resolution of Contract Disputes</a> <a href="#">References</a> <a href="#">Problems</a> <a href="#">Footnotes</a>	



[http://pmbook.ce.cmu.edu/08\\_Construction\\_Pricing\\_and\\_Contracting.html](http://pmbook.ce.cmu.edu/08_Construction_Pricing_and_Contracting.html)

## 8. Construction Pricing and Contracting

### 8.1 Pricing for Constructed Facilities

Because of the unique nature of constructed facilities, it is almost imperative to have a separate price for each facility. The construction contract price includes the direct project cost including field supervision expenses plus the markup imposed by contractors for general overhead expenses and profit. The factors influencing a facility price will vary by type of facility and location as well. Within each of the major categories of construction such as residential housing, commercial buildings, industrial complexes and infrastructure, there are smaller segments which have very different environments with regard to price setting. However, all pricing arrangements have some common features in the form of the legal documents binding the owner and the supplier(s) of the facility. Without addressing special issues in various industry segments, the most common types of pricing arrangements can be described broadly to illustrate the basic principles.

#### Competitive Bidding

The basic structure of the bidding process consists of the formulation of detailed plans and specifications of a facility based on the objectives and requirements of the owner, and the invitation of qualified contractors to bid for the right to execute the project. The definition of a qualified contractor usually calls for a minimal evidence of previous experience and financial stability. In the private sector, the owner has considerable latitude in selecting the bidders, ranging from open competition to the restriction of bidders to a few favored contractors. In the public sector, the rules are carefully delineated to place all qualified contractors on an equal footing for competition, and strictly enforced to prevent collusion among contractors and unethical or illegal actions by public officials.

Detailed plans and specifications are usually prepared by an architectural/engineering firm which oversees the bidding process on behalf of the owner. The final bids are normally submitted on either a lump sum or unit price basis, as stipulated by the owner. A lump sum bid represents the total price for

which a contractor offers to complete a facility according to the detailed plans and specifications. Unit price bidding is used in projects for which the quantity of materials or the amount of labor involved in some key tasks is particularly uncertain. In such cases, the contractor is permitted to submit a list of unit prices for those tasks, and the final price used to determine the lowest bidder is based on the lump sum price computed by multiplying the quoted unit price for each specified task by the corresponding quantity in the owner's estimates for quantities. However, the total payment to the winning contractor will be based on the actual quantities multiplied by the respective quoted unit prices.

## **Negotiated Contracts**

Instead of inviting competitive bidding, private owners often choose to award construction contracts with one or more selected contractors. A major reason for using negotiated contracts is the flexibility of this type of pricing arrangement, particularly for projects of large size and great complexity or for projects which substantially duplicate previous facilities sponsored by the owner. An owner may value the expertise and integrity of a particular contractor who has a good reputation or has worked successfully for the owner in the past. If it becomes necessary to meet a deadline for completion of the project, the construction of a project may proceed without waiting for the completion of the detailed plans and specifications with a contractor that the owner can trust. However, the owner's staff must be highly knowledgeable and competent in evaluating contractor proposals and monitoring subsequent performance.

Generally, negotiated contracts require the reimbursement of direct project cost plus the contractor's fee as determined by one of the following methods:

1. Cost plus fixed percentage
2. Cost plus fixed fee
3. Cost plus variable fee
4. Target estimate
5. Guaranteed maximum price or cost

The fixed percentage or fixed fee is determined at the outset of the project, while variable fee and target estimates are used as an incentive to reduce costs by sharing any cost savings. A guaranteed maximum cost arrangement imposes a penalty on a contractor for cost overruns and failure to complete the project on time. With a guaranteed maximum price contract, amounts below the maximum are typically shared between the owner and the contractor, while the contractor is responsible for costs above the maximum.

## **Speculative Residential Construction**

In residential construction, developers often build houses and condominiums in anticipation of the demand of home buyers. Because the basic needs of home buyers are very similar and home designs can be standardized to some degree, the probability of finding buyers of good housing units within a relatively short time is quite high. Consequently, developers are willing to undertake speculative building and lending institutions are also willing to finance such construction. The developer essentially set the price for each housing unit as the market will bear, and can adjust the prices of remaining units at any given time according to the market trend.

## **Force-Account Construction**

Some owners use in-house labor forces to perform a substantial amount of construction, particularly for addition, renovation and repair work. Then, the total of the force-account charges including in-house overhead expenses will be the pricing arrangement for the construction.



[Back to top](#)

## 8.2 Contract Provisions for Risk Allocation

Provisions for the allocation of risk among parties to a contract can appear in numerous areas in addition to the total construction price. Typically, these provisions assign responsibility for covering the costs of possible or unforeseen occurrences. A partial list of responsibilities with concomitant risk that can be assigned to different parties would include:

- Force majeure (i.e., this provision absolves an owner or a contractor for payment for costs due to "Acts of God" and other external events such as war or labor strikes)
- Indemnification (i.e., this provision absolves the indemnified party from any payment for losses and damages incurred by a third party such as adjacent property owners.)
- Liens (i.e., assurances that third party claims are settled such as "mechanics liens" for worker wages),
- Labor laws (i.e., payments for any violation of labor laws and regulations on the job site),
- Differing site conditions (i.e., responsibility for extra costs due to unexpected site conditions),
- Delays and extensions of time,
- Liquidated damages (i.e., payments for any facility defects with payment amounts agreed to in advance)
- Consequential damages (i.e., payments for actual damage costs assessed upon impact of facility defects),
- Occupational safety and health of workers,
- Permits, licenses, laws, and regulations,
- Equal employment opportunity regulations,
- Termination for default by contractor,
- Suspension of work,
- Warranties and guarantees.

The language used for specifying the risk assignments in these areas must conform to legal requirements and past interpretations which may vary in different jurisdictions or over time. Without using standard legal language, contract provisions may be unenforceable. Unfortunately, standard legal language for this purpose may be difficult to understand. As a result, project managers often have difficulty in interpreting their particular responsibilities. Competent legal counsel is required to advise the different parties to an agreement about their respective responsibilities.

Standard forms for contracts can be obtained from numerous sources, such as the American Institute of Architects (AIA) or the Associated General Contractors (AGC). These standard forms may include risk and responsibility allocations which are unacceptable to one or more of the contracting parties. In particular, standard forms may be biased to reduce the risk and responsibility of the originating organization or group. Parties to a contract should read and review all contract documents carefully.

The three examples appearing below illustrate contract language resulting in different risk assignments between a contractor (CONTRACTOR) and an owner (COMPANY). Each contract provision allocates different levels of indemnification risk to the contractor. [\[1\]](#)

### Example 8-1: A Contract Provision Example with High Contractor Risk

"Except where the sole negligence of COMPANY is involved or alleged, CONTRACTOR shall indemnify and hold harmless COMPANY, its officers, agents and employees, from and against any and all loss, damage, and liability and from any and all claims for damages on

account of or by reason of bodily injury, including death, not limited to the employees of CONTRACTOR, COMPANY, and of any subcontractor or CONTRACTOR, and from and against any *and all damages to property, including property of COMPANY and third parties, direct and/or consequential*, caused by or arising out of, in whole or in part, or claimed to have been caused by or to have arisen out of, in whole or in part, an act of omission of CONTRACTOR or its agents, employees, vendors, or subcontractors, of their employees or agents in connection with the performance of the Contract Documents, *whether or not insured against*; and CONTRACTOR shall, at its own cost and expense, defend any claim, suit, action or proceeding, whether groundless or not, which may be commenced against COMPANY by reason thereof or in connection therewith, and CONTRACTOR shall pay any and all judgments which may be recovered in such action, claim, proceeding or suit, and defray any and all expenses, including costs and attorney's fees which may be incurred by reason of such actions, claims, proceedings, or suits."

**Comment:** This is a very burdensome provision for the contractor. It makes the contractor responsible for practically every conceivable occurrence and type of damage, except when a claim for loss or damages is due to the *sole* negligence of the owner. As a practical matter, sole negligence on a construction project is very difficult to ascertain because the work is so inter-twined. Since there is no dollar limitation to the contractor's exposure, sufficient liability coverage to cover worst scenario risks will be difficult to obtain. The best the contractor can do is to obtain as complete and broad excess liability insurance coverage as can be purchased. This insurance is costly, so the contractor should insure the contract price is sufficiently high to cover the expense.

#### **Example 8-2: An Example Contract Provision with Medium Risk Allocation to Contractor**

"CONTRACTOR shall protect, defend, hold harmless, and indemnify COMPANY from and against any loss, damage, claim, action, liability, or demand whatsoever (including, with limitation, costs, expenses, and attorney's fees, whether for appeals or otherwise, in connection therewith), arising out of any personal injury (including, without limitation, injury to any employee of COMPANY, CONTRACTOR or any subcontractor), arising out of any personal injury (including, without limitation, injury to any employee of COMPANY, CONTRACTOR, or any subcontractor), including death resulting therefrom or out of any damage to or loss or destruction of property, real and or personal (including property of COMPANY, CONTRACTOR, and any subcontractor, and including tools and equipment whether owned, rented, or used by CONTRACTOR, any subcontractor, or any workman) in any manner based upon, occasioned by, or attributable or related to the performance, whether by the CONTRACTOR or any subcontractor, of the Work or any part thereof, and CONTRACTOR shall at its own expense defend any and all actions based thereon, except where said personal injury or property damage is caused by the negligence of COMPANY or COMPANY'S employees. Any loss, damage, cost expense or attorney's fees incurred by COMPANY in connection with the foregoing may, in addition to other remedies, be deducted from CONTRACTOR'S compensation, then due or thereafter to become due. *COMPANY shall effect for the benefit of CONTRACTOR a waiver of subrogation on the existing facilities, including consequential damages such as, but not by way of limitation, loss of profit and loss of product or plant downtime but excluding any deductibles which shall exist as at the date of this CONTRACT; provided, however, that said waiver of subrogation shall be expanded to include all said deductible amounts on the acceptance of the Work by COMPANY.*"

**Comment:** This clause provides the contractor considerable relief. He still has unlimited exposure for injury to all persons and third party property but only to the extent caused by the contractor's negligence.

The "sole" negligence issue does not arise. Furthermore, the contractor's liability for damages to the owner's property—a major concern for contractors working in petrochemical complexes, at times worth billions—is limited to the owner's insurance deductible, and the owner's insurance carriers have no right of recourse against the contractor. The contractor's limited exposure regarding the owner's facilities ends on completion of the work.

### **Example 8-3: An Example Contract Provision with Low Risk Allocation to Contractor**

"CONTRACTOR hereby agrees to indemnify and hold COMPANY and/or any parent, subsidiary, or affiliate, or COMPANY and/or officers, agents, or employees of any of them, harmless from and against any loss or liability arising directly or indirectly out of any claim or cause of action for loss or damage to property including, but not limited to, CONTRACTOR'S property and COMPANY'S property and for injuries to or death of persons including but not limited to CONTRACTOR'S employees, caused by or resulting from the performance of the work by CONTRACTOR, its employees, agents, and subcontractors and shall, at the option of COMPANY, defend COMPANY at CONTRACTOR'S sole expense in any litigation involving the same regardless of whether such work is performed by CONTRACTOR, its employees, or by its subcontractors, their employees, or all or either of them. *In all instances, CONTRACTOR'S indemnity to COMPANY shall be limited to the proceeds of CONTRACTOR'S umbrella liability insurance coverage.*"

**Comment:** With respect to indemnifying the owner, the contractor in this provision has minimal out-of-pocket risk. Exposure is limited to whatever can be collected from the contractor's insurance company.

[Back to top](#)

## **8.3 Risks and Incentives on Construction Quality**

All owners want quality construction with reasonable costs, but not all are willing to share risks and/or provide incentives to enhance the quality of construction. In recent years, more owners recognize that they do not get the best quality of construction by squeezing the last dollar of profit from the contractor, and they accept the concept of risk sharing/risk assignment in principle in letting construction contracts. However, the implementation of such a concept in the past decade has received mixed results.

Many public owners have been the victims of their own schemes, not only because of the usual requirement in letting contracts of public works through competitive bidding to avoid favoritism, but at times because of the sheer weight of entrenched bureaucracy. Some contractors steer away from public works altogether; others submit bids at higher prices to compensate for the restrictive provisions of contract terms. As a result, some public authorities find that either there are few responsible contractors responding to their invitations to submit bids or the bid prices far exceed their engineers' estimates. Those public owners who have adopted the federal government's risk sharing/risk assignment contract concepts have found that while initial bid prices may have decreased somewhat, claims and disputes on contracts are more frequent than before, and notably more so than in privately funded construction. Some of these claims and disputes can no doubt be avoided by improving the contract provisions. [\[2\]](#)

Since most claims and disputes arise most frequently from lump sum contracts for both public and private owners, the following factors associated with lump sum contracts are particularly noteworthy:

- unbalanced bids in unit prices on which periodic payment estimates are based.
- change orders subject to negotiated payments

- changes in design or construction technology
- incentives for early completion

An unbalanced bid refers to raising the unit prices on items to be completed in the early stage of the project and lowering the unit prices on items to be completed in the later stages. The purpose of this practice on the part of the contractor is to ease its burden of construction financing. It is better for owners to offer explicit incentives to aid construction financing in exchange for lower bid prices than to allow the use of hidden unbalanced bids. Unbalanced bids may also occur if a contractor feels some item of work was underestimated in amount, so that a high unit price on that item would increase profits. Since lump sum contracts are awarded on the basis of low bids, it is difficult to challenge the low bidders on the validity of their unit prices except for flagrant violations. Consequently remedies should be sought by requesting the contractor to submit pertinent records of financial transactions to substantiate the expenditures associated with its monthly billings for payments of work completed during the period.

One of the most contentious issues in contract provisions concerns the payment for change orders. The owner and its engineer should have an appreciation of the effects of changes for specific items of work and negotiate with the contractor on the identifiable cost of such items. The owner should require the contractor to submit the price quotation within a certain period of time after the issuance of a change order and to assess whether the change order may cause delay damages. If the contract does not contain specific provisions on cost disclosures for evaluating change order costs, it will be difficult to negotiate payments for change orders and claim settlements later.

In some projects, the contract provisions may allow the contractor to provide alternative design and/or construction technology. The owner may impose different mechanisms for pricing these changes. For example, a contractor may suggest a design or construction method change that fulfills the performance requirements. Savings due to such changes may accrue to the contractor or the owner, or may be divided in some fashion between the two. The contract provisions must reflect the owners risk-reward objectives in calling for alternate design and/or construction technology. While innovations are often sought to save money and time, unsuccessful innovations may require additional money and time to correct earlier misjudgment. At worst, a failure could have serious consequences.

In spite of admonitions and good intentions for better planning before initiating a construction project, most owners want a facility to be in operation as soon as possible once a decision is made to proceed with its construction. Many construction contracts contain provisions of penalties for late completion beyond a specified deadline; however, unless such provisions are accompanied by similar incentives for early completion, they may be ruled unenforceable in court. Early completion may result in significant savings, particularly in rehabilitation projects in which the facility users are inconvenienced by the loss of the facility and the disruption due to construction operations.

#### **Example 8-4: Arkansas Rice Growers Cooperative Association v. Alchemy Industries**

A 1986 court case can illustrate the assumption of risk on the part of contractors and design professionals. [3] The Arkansas Rice Growers Cooperative contracted with Alchemy Industries, Inc. to provide engineering and construction services for a new facility intended to generate steam by burning rice hulls. Under the terms of the contract, Alchemy Industries guaranteed that the completed plant would be capable of "reducing a minimum of seven and one-half tons of rice hulls per hour to an ash and producing a minimum of 48 million BTU's per hour of steam at 200 pounds pressure." Unfortunately, the finished plant did not meet this performance standard, and the Arkansas Rice Growers Cooperative Association sued Alchemy Industries and its subcontractors for breach of warranty. Damages of almost \$1.5 million were awarded to the Association.

[Back to top](#)

## 8.4 Types of Construction Contracts

While construction contracts serve as a means of pricing construction, they also structure the allocation of risk to the various parties involved. The owner has the sole power to decide what type of contract should be used for a specific facility to be constructed and to set forth the terms in a contractual agreement. It is important to understand the risks of the contractors associated with different types of construction contracts.

### Lump Sum Contract

In a lump sum contract, the owner has essentially assigned all the risk to the contractor, who in turn can be expected to ask for a higher markup in order to take care of unforeseen contingencies. Beside the fixed lump sum price, other commitments are often made by the contractor in the form of submittals such as a specific schedule, the management reporting system or a quality control program. If the actual cost of the project is underestimated, the underestimated cost will reduce the contractor's profit by that amount. An overestimate has an opposite effect, but may reduce the chance of being a low bidder for the project.

### Unit Price Contract

In a unit price contract, the risk of inaccurate estimation of uncertain quantities for some key tasks has been removed from the contractor. However, some contractors may submit an "unbalanced bid" when it discovers large discrepancies between its estimates and the owner's estimates of these quantities. Depending on the confidence of the contractor on its own estimates and its propensity on risk, a contractor can slightly raise the unit prices on the underestimated tasks while lowering the unit prices on other tasks. If the contractor is correct in its assessment, it can increase its profit substantially since the payment is made on the actual quantities of tasks; and if the reverse is true, it can lose on this basis. Furthermore, the owner may disqualify a contractor if the bid appears to be heavily unbalanced. To the extent that an underestimate or overestimate is caused by changes in the quantities of work, neither error will effect the contractor's profit beyond the markup in the unit prices.

### Cost Plus Fixed Percentage Contract

For certain types of construction involving new technology or extremely pressing needs, the owner is sometimes forced to assume all risks of cost overruns. The contractor will receive the actual direct job cost plus a fixed percentage, and have little incentive to reduce job cost. Furthermore, if there are pressing needs to complete the project, overtime payments to workers are common and will further increase the job cost. Unless there are compelling reasons, such as the urgency in the construction of military installations, the owner should not use this type of contract.

### Cost Plus Fixed Fee Contract

Under this type of contract, the contractor will receive the actual direct job cost plus a fixed fee, and will have some incentive to complete the job quickly since its fee is fixed regardless of the duration of the project. However, the owner still assumes the risks of direct job cost overrun while the contractor may risk the erosion of its profits if the project is dragged on beyond the expected time.

### Cost Plus Variable Percentage Contract

For this type of contract, the contractor agrees to a penalty if the actual cost exceeds the estimated job cost, or a reward if the actual cost is below the estimated job cost. In return for taking the risk on its own estimate, the contractor is allowed a variable percentage of the direct job-cost for its fee. Furthermore, the project duration is usually specified and the contractor must abide by the deadline for completion. This type of contract allocates considerable risk for cost overruns to the owner, but also provides incentives to contractors to reduce costs as much as possible.

### **Target Estimate Contract**

This is another form of contract which specifies a penalty or reward to a contractor, depending on whether the actual cost is greater than or less than the contractor's estimated direct job cost. Usually, the percentages of savings or overrun to be shared by the owner and the contractor are predetermined and the project duration is specified in the contract. Bonuses or penalties may be stipulated for different project completion dates.

### **Guaranteed Maximum Cost Contract**

When the project scope is well defined, an owner may choose to ask the contractor to take all the risks, both in terms of actual project cost and project time. Any work change orders from the owner must be extremely minor if at all, since performance specifications are provided to the owner at the outset of construction. The owner and the contractor agree to a project cost guaranteed by the contractor as maximum. There may be or may not be additional provisions to share any savings if any in the contract. This type of contract is particularly suitable for *turnkey* operation.

[Back to top](#)

## **8.5 Relative Costs of Construction Contracts**

Regardless of the type of construction contract selected by the owner, the contractor recognizes that the actual construction cost will never be identical to its own estimate because of imperfect information. Furthermore, it is common for the owner to place work change orders to modify the original scope of work for which the contractor will receive additional payments as stipulated in the contract. The contractor will use different markups commensurate with its market circumstances and with the risks involved in different types of contracts, leading to different contract prices at the time of bidding or negotiation. The type of contract agreed upon may also provide the contractor with greater incentives to try to reduce costs as much as possible. The contractor's gross profit at the completion of a project is affected by the type of contract, the accuracy of its original estimate, and the nature of work change orders. The owner's actual payment for the project is also affected by the contract and the nature of work change orders.

In order to illustrate the relative costs of several types of construction contracts, the pricing mechanisms for such construction contracts are formulated on the same direct job cost plus corresponding markups reflecting the risks. Let us adopt the following notation:

E= contractor's original estimate of the direct job cost at the time of contract award

M = amount of markup by the contractor in the contract

B = estimated construction price at the time of signing contract

A = contractor's actual cost for the original scope of work in the contract

U = underestimate of the cost of work in the original estimate (with negative value of U denoting an overestimate)

- $C$  = additional cost of work due to change orders  
 $P$  = actual payment to contractor by the owner  
 $F$  = contractor's gross profit  
 $R$  = basic percentage markup above the original estimate for fixed fee contract  
 $R_i$  = premium percentage markup for contract type  $i$  such that the total percentage markup is  $(R + R_i)$ ,  
 e.g.  $(R + R_1)$  for a lump sum contract,  $(R + R_2)$  for a unit price contract, and  $(R + R_3)$  for a  
 guaranteed maximum cost contract  
 $N$  = a factor in the target estimate for sharing the savings in cost as agreed upon by the owner and the  
 contractor, with  $0 \leq N \leq 1$ .

At the time of a contract award, the contract price is given by:

$$(8.1) \quad B = E + M$$

The underestimation of the cost of work in the original contract is defined as:

$$(8.2) \quad U = A - E$$

Then, at the completion of the project, the contractor's actual cost for the original scope of work is:

$$(8.3) \quad A = E + U$$

For various types of construction contracts, the contractor's markup and the price for construction agreed to in the contract are shown in Table 8-1. Note that at the time of contract award, it is assumed that  $A = E$ , even though the effects of underestimation on the contractor's gross profits are different for various types of construction contracts when the actual cost of the project is assessed upon its completion.

**TABLE 8-1** Original Estimated Contract Prices

Type of Contract	Markup	Contract Price
1. Lump sum	$M = (R + R_1)E$	$B = (1 + R + R_1)E$
2. Unit price	$M = (R + R_2)E$	$B = (1 + R + R_2)E$
3. Cost plus fixed %	$M = RA = RE$	$B = (1 + R)E$
4. Cost plus fixed fee	$M = RE$	$B = (1 + R)E$
5. Cost plus variable %	$M = R(2E - A) = RE$	$B = (1 + R)E$
6. Target estimate	$M = RE + N(E - A) = RE$	$B = (1 + R)E$
7. Guaranteed max cost	$M = (R + R_3)E$	$B = (1 + R + R_3)E$

Payments of change orders are also different in contract provisions for different types of contracts. Suppose that payments for change orders agreed upon for various types of contracts are as shown in column 2 of Table 8-2. The owner's actual payments based on these provisions as well as the incentive provisions for various types of contracts are given in column 3 of Table 8-2. The corresponding

contractor's profits under various contractual arrangements are shown in Table 8-3.

**TABLE 8-2** Owner's Actual Payment with Different Contract Provisions

Type of Contract	Change Order Payment	Owner's Payment
1. Lump sum	$C(1 + R + R_1)$	$P = B + C(1 + R + R_1)$
2. Unit price	$C(1 + R + R_2)$	$P = (1 + R + R_2)A + C$
3. Cost plus fixed %	$C(1 + R)$	$P = (1 + R)(A + C)$
4. Cost plus fixed fee	$C$	$P = RE + A + C$
5. Cost plus variable %	$C(1 + R)$	$P = R(2E - A + C) + A + C$
6. Target estimate	$C$	$P = RE + N(E - A) + A + C$
7. Guaranteed max cost	0	$P = B$

**TABLE 8-3** Contractor's Gross Profit with Different Contract Provisions

Type of Contract	Profit from Change Order	Contractor's Gross Profit
1. Lump sum	$C(R + R_1)$	$F = E - A + (R + R_1)(E + C)$
2. Unit price	$C(R + R_2)$	$F = (R + R_2)(A + C)$
3. Cost plus fixed %	$CR$	$F = R(A + C)$
4. Cost plus fixed fee	0	$F = RE$
5. Cost plus variable %	$CR$	$F = R(2E - A + C)$
6. Target estimate	0	$F = RE + N(E - A)$
7. Guaranteed max cost	-C	$F = (1 + R + R_3)E - A - C$

It is important to note that the equations in Tables 8-1 through 8-3 are illustrative, subject to the simplified conditions of payments assumed under the various types of contracts. When the negotiated conditions of payment are different, the equations must also be modified.

### Example 8-5: Contractor's Gross Profits under Different Contract Arrangements

Consider a construction project for which the contractor's original estimate is \$6,000,000. For various types of contracts,  $R = 10\%$ ,  $R_1 = 2\%$ ,  $R_2 = 1\%$ ,  $R_3 = 5\%$  and  $N = 0.5$ . The contractor is not compensated for change orders under the guaranteed maximum cost contract if the total cost for the change orders is within 6% (\$360,000) of the original estimate. Determine the contractor's gross profit for each of the seven types of construction contracts for each of the following conditions.

- $U = 0$ ,  $C = 0$
- $U = 0$ ,  $C = 6\%$   $E = \$360,000$
- $U = 4\%$   $E = \$240,000$ ,  $C = 0$
- $U = 4\%$   $E = \$240,000$   $C = 6\%$   $E = \$360,000$
- $U = -4\%$   $E = -\$240,000$ ,  $C = 0$
- $U = -4\%$   $E = -\$240,000$ ,  $C = 6\%$   $E = \$360,000$

In this example, the percentage markup for the cost plus fixed percentage contract is 10% which is used as the bench mark for comparison. The percentage markup for the lump sum contract is 12% while that for the unit price contract is 11%, reflecting the degrees of higher risk. The fixed fee for the cost plus fixed fee is based on 10% of the estimated cost, which is comparable to the cost plus fixed percentage



contract if there is no overestimate or underestimate in cost. The basic percentage markup is 10% for both the cost plus variable percentage contract and the target estimator contract, but they are subject to incentive bonuses and penalties that are built in the formulas for owners' payments. The percentage markup for the guaranteed maximum cost contract is 15% to account for the high risk undertaken by the contractor. The results of computation for all seven types of contracts under different conditions of underestimation U and change order C are shown in Table 8-4

**TABLE 8-4** Contractor's Gross Profits under Different Conditions (in \$1,000)

Type of Contract	U=0	U=0	U=4%E	U=4%E	U=-4%E	U=-4%E
	C=0	C=6%E	C=0	C=6%E	C=0	C=6%E
1. lump sum	\$720	\$763	\$480	\$523	\$960	\$1,003
2. unit price	660	700	686	726	634	674
3. cost + fixed %	600	636	624	660	576	612
4. cost + fixed fee	600	600	600	600	600	600
5. cost + Var %	600	636	576	616	624	660
6. target estimate	600	600	480	480	720	720
7. guar. max. cost	900	540	660	300	1,140	780

### Example 8-6: Owner's Payments under Different Contract Arrangements

Using the data in Example 8-5, determine the owner's actual payment for each of the seven types of construction contracts for the same conditions of U and C. The results of computation are shown in Table 8-5.

**TABLE 8-5** Owner's Actual Payments under Different Conditions (in \$1,000)

Type of Contract	U=0	U=0	U=4%E	U=4%E	U=-4%E	U=-4%E
	C=0	C=6%E	C=0	C=6%E	C=0	C=6%E
1. lump sum	\$6,720	\$7,123	\$6,720	\$7,123	\$6,720	\$7,123
2. unit price	6,660	7,060	6,926	7,326	6,394	6,794
3. cost + fixed %	6,600	6,996	6,864	7,260	6,336	6,732
4. cost + fixed fee	6,600	6,960	6,840	7,200	6,360	6,720
5. cost + Var %	6,600	6,996	6,816	7,212	6,384	6,780
6. target estimate	6,600	6,960	6,720	7,080	6,480	6,840
7. guar. max. cost	6,900	6,900	6,900	6,900	6,900	6,900

[Back to top](#)

## 8.6 Principles of Competitive Bidding

Competitive bidding on construction projects involves decision making under uncertainty where one of the greatest sources of the uncertainty for each bidder is due to the unpredictable nature of his competitors. Each bid submitted for a particular job by a contractor will be determined by a large number of factors, including an estimate of the direct job cost, the general overhead, the confidence that the management has in this estimate, and the immediate and long-range objectives of management. So many factors are involved that it is impossible for a particular bidder to attempt to predict exactly what the bids submitted by its competitors will be.

It is useful to think of a bid as being made up of two basic elements: (1) the estimate of direct job cost, which includes direct labor costs, material costs, equipment costs, and direct field supervision; and (2) the markup or return, which must be sufficient to cover a portion of general overhead costs and allow a fair profit on the investment. A large return can be assured simply by including a sufficiently high markup. However, the higher the markup, the less chance there will be of getting the job. Consequently a contractor who includes a very large markup on every bid could become bankrupt from lack of business. Conversely, the strategy of bidding with very little markup in order to obtain high volume is also likely to lead to bankruptcy. Somewhere in between the two extreme approaches to bidding lies an "optimum markup" which considers both the return and the likelihood of being low bidder in such a way that, over the long run, the average return is maximized.

From all indications, most contractors confront uncertain bidding conditions by exercising a high degree of subjective judgment, and each contractor may give different weights to various factors. The decision on the bid price, if a bid is indeed submitted, reflects the contractor's best judgment on how well the proposed project fits into the overall strategy for the survival and growth of the company, as well as the contractor's propensity to risk greater profit versus the chance of not getting a contract.

One major concern in bidding competitions is the amount of "money left on the table," of the difference between the winning and the next best bid. The winning bidder would like the amount of "money left on the table" to be as small as possible. For example, if a contractor wins with a bid of \$200,000, and the next lowest bid was \$225,000 (representing \$25,000 of "money left on the table"), then the winning contractor would have preferred to have bid \$220,000 (or perhaps \$224,999) to increase potential profits.

Some of the major factors impacting bidding competitions include:

### **Exogenous Economic Factors**

Contractors generally tend to specialize in a submarket of construction and concentrate their work in particular geographic locations. The level of demand in a submarket at a particular time can influence the number of bidders and their bid prices. When work is scarce in the submarket, the average number of bidders for projects will be larger than at times of plenty. The net result of scarcity is likely to be the increase in the number of bidders per project and downward pressure on the bid price for each project in the submarket. At times of severe scarcity, some contractors may cross the line between segments to expand their activities, or move into new geographic locations to get a larger share of the existing submarket. Either action will increase the risks incurred by such contractors as they move into less familiar segments or territories. The trend of market demand in construction and of the economy at large may also influence the bidding decisions of a contractor in other ways. If a contractor perceives drastic increases in labor wages and material prices as a result of recent labor contract settlements, it may take into consideration possible increases in unit prices for determining the direct project cost. Furthermore, the perceptions of increase in inflation rates and interest rates may also cause the contractor to use a higher markup to hedge the uncertainty. Consequently, at times of economic expansion and/or higher inflation rate, contractors are reluctant to commit themselves to long-term fixed price contracts.

### **Characteristics of Bidding Competition**

All other things being equal, the probability of winning a contract diminishes as more bidders participate in the competition. Consequently, a contractor tries to find out as much information as possible about the number and identities of potential bidders on a specific project. Such information is often available in the *Dodge Bulletin* <*Dodge Bulletin* (daily publication), F. W. Dodge Corp., New York, NY.> or similar publications which provide data of potential projects and names of contractors who have taken out plans and specifications. For certain segments, potential competitors may be identified through private contacts,

and bidders often confront the same competitor's project after project since they have similar capabilities and interests in undertaking the same type of work, including size, complexity and geographical location of the projects. A general contractor may also obtain information of potential subcontractors from publications such as *Credit Reports* (*Credit Reports*, Building Construction Division, and Bradstreet, Inc., New York, N.Y.) published by Dun and Bradstreet, Inc. However, most contractors form an extensive network with a group of subcontractors with whom they have had previous business transactions. They usually rely on their own experience in soliciting subcontract bids before finalizing a bid price for the project.

### **Objectives of General Contractors in Bidding**

The bidding strategy of some contractors are influenced by a policy of minimum percentage markup for general overhead and profit. However, the percentage markup may also reflect additional factors stipulated by the owner such as high retention and slow payments for completed work, or perceptions of uncontrollable factors in the economy. The intensity of a contractor's efforts in bidding a specific project is influenced by the contractor's desire to obtain additional work. The winning of a particular project may be potentially important to the overall mix of work in progress or the cash flow implications for the contractor. The contractor's decision is also influenced by the availability of key personnel in the contractor organization. The company sometimes wants to reserve its resources for future projects, or commits itself to the current opportunity for different reasons.

### **Contractor's Comparative Advantages**

A final important consideration in forming bid prices on the part of contractors are the possible special advantages enjoyed by a particular firm. As a result of lower costs, a particular contractor may be able to impose a higher profit markup yet still have a lower total bid than competitors. These lower costs may result from superior technology, greater experience, better management, better personnel or lower unit costs. A comparative cost advantage is the most desirable of all circumstances in entering a bid competition.

[Back to top](#)

## **8.7 Principles of Contract Negotiation**

Negotiation is another important mechanism for arranging construction contracts. Project managers often find themselves as participants in negotiations, either as principal negotiators or as expert advisors. These negotiations can be complex and often present important opportunities and risks for the various parties involved. For example, negotiation on work contracts can involve issues such as completion date, arbitration procedures, special work item compensation, contingency allowances as well as the overall price. As a general rule, exogenous factors such as the history of a contractor and the general economic climate in the construction industry will determine the results of negotiations. However, the skill of a negotiator can affect the possibility of reaching an agreement, the profitability of the project, the scope of any eventual disputes, and the possibility for additional work among the participants. Thus, negotiations are an important task for many project managers. Even after a contract is awarded on the basis of competitive bidding, there are many occasions in which subsequent negotiations are required as conditions change over time.

In conducting negotiations between two parties, each side will have a series of objectives and constraints. The overall objective of each party is to obtain the most favorable, acceptable agreement. A two party, one issue negotiation illustrates this fundamental point. Suppose that a developer is willing to pay up to

\$500,000 for a particular plot of land, whereas the owner would be willing to sell the land for \$450,000 or more. These maximum and minimum sales prices represent *constraints* on any eventual agreement. In this example, any purchase price between \$450,000 and \$500,000 is acceptable to both of the involved parties. This range represents a *feasible agreement space*. Successful negotiations would conclude in a sales price within this range. Which party receives the \$50,000 in the middle range between \$450,000 and \$500,000 would typically depend upon the negotiating skills and special knowledge of the parties involved. For example, if the developer was a better negotiator, then the sales price would tend to be close to the minimum \$450,000 level.

With different constraints, it might be impossible to reach an agreement. For example, if the owner was only willing to sell at a price of \$550,000 while the developer remains willing to pay only \$500,000, then there would be no possibility for an agreement between the two parties. Of course, the two parties typically do not know at the beginning of negotiations if agreements will be possible. But it is quite important for each party to the negotiation to have a sense of their own *reservation price*, such as the owner's minimum selling price or the buyer's maximum purchase price in the above example. This reservation price is equal to the value of the best alternative to a negotiated agreement.

Poor negotiating strategies adopted by one or the other party may also preclude an agreement even with the existence of a feasible agreement range. For example, one party may be so demanding that the other party simply breaks off negotiations. In effect, negotiations are not a well behaved solution methodology for the resolution of disputes.

The possibility of negotiating failures in the land sale example highlights the importance of negotiating style and strategy with respect to revealing information. Style includes the extent to which negotiators are willing to seem reasonable, the type of arguments chosen, the forcefulness of language used, etc. Clearly, different negotiating styles can be more or less effective. Cultural factors are also extremely important. American and Japanese negotiating styles differ considerably, for example. Revealing information is also a negotiating decision. In the land sale case, some negotiators would readily reveal their reserve or constraint prices, whereas others would conceal as much information as possible (i.e. "play their cards close to the vest") or provide misleading information.

In light of these tactical problems, it is often beneficial to all parties to adopt objective standards in determining appropriate contract provisions. These standards would prescribe a particular agreement or a method to arrive at appropriate values in a negotiation. Objective standards can be derived from numerous sources, including market values, precedent, professional standards, what a court would decide, etc. By using objective criteria of this sort, personalities and disruptive negotiating tactics do not become impediments to reaching mutually beneficial agreements.

With additional issues, negotiations become more complex both in procedure and in result. With respect to procedure, the sequence in which issues are defined or considered can be very important. For example, negotiations may proceed on an issue-by-issue basis, and the outcome may depend upon the exact sequence of issues considered. Alternatively, the parties may proceed by proposing complete agreement packages and then proceed to compare packages. With respect to outcomes, the possibility of the parties having different valuations or weights on particular issues arises. In this circumstance, it is possible to trade-off the outcomes on different issues to the benefit of both parties. By yielding on an issue of low value to himself but high value to the other party, concessions on other issues may be obtained.

The notion of Pareto optimal agreements can be introduced to identify negotiated agreements in which no change in the agreement can simultaneously make both parties better off. Figure 8-1 illustrates Pareto optimal agreements which can be helpful in assessing the result of multiple issue negotiations. In this figure, the axes represent the satisfaction or desirability of agreements to the parties, denoted I and II.

This representation assumes that one can place a dollar or utility value on various agreements reached in a multiple-issue negotiation between two parties. Points in the graph represent particular agreements on the different issues under consideration. A particular point may be obtained by more than one contract agreement. The curved line encloses the set of all feasible agreements; any point in this area is an acceptable agreement. Each party has a minimum acceptable satisfaction level in this graph. Points on the interior of this feasible area represent *inferior* agreements since some other agreement is possible that benefits both parties. For example, point B represents a more desirable agreement than point A. In the previous example, point B might represent a purchase price of \$490,000 and an immediate purchase, whereas point A might represent a \$475,000 sale price and a six month delay. The feasible points that are not inferior constitute the set of Pareto optimal or efficient agreements; these points lie on the north-east quadrant of the feasible region as marked on the figure.

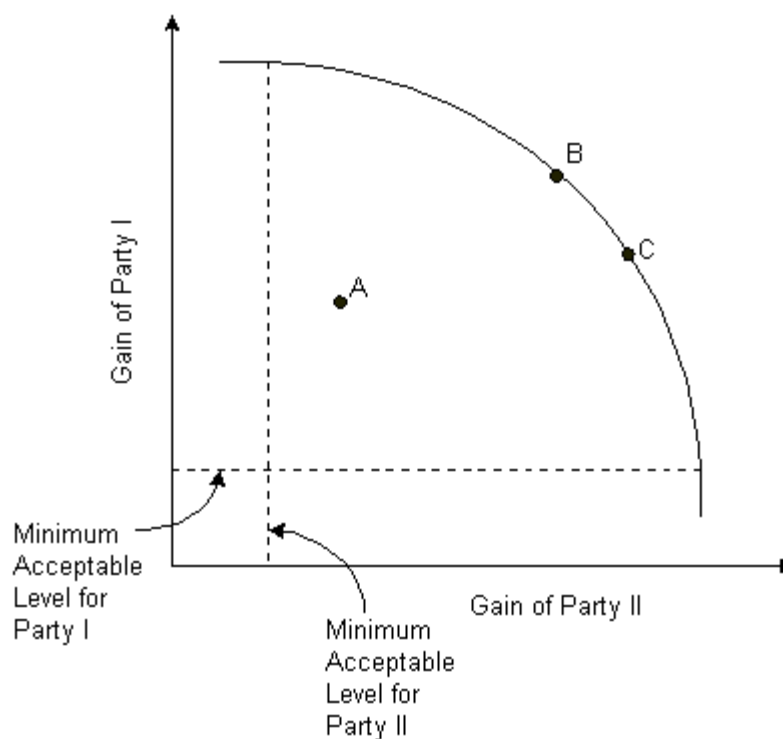

**Figure 8-1** Illustration of a Pareto Optimal Agreement Set

The definition of Pareto optimal agreements allows one to assess at least one aspect of negotiated outcomes. If two parties arrive at an inferior agreement (such as point A in Figure 8-1), then the agreement could be improved *to the benefit of both parties*. In contrast, different Pareto optimal agreements (such as points B and C in Figure 8-1) can represent widely different results to the individual parties but do not have the possibility for joint improvement.

Of course, knowledge of the concept of Pareto optimal agreements does not automatically give any guidance on what might constitute the best agreements. Much of the skill in contract negotiation comes from the ability to invent new options that represent mutual gains. For example, devising contract incentives for speedier completion of projects may result in benefits to both contractors and the owner.

### Example 8-7: Effects of different value perceptions.

Suppose that the closing date for sale of the land in the previous case must also be decided in negotiation. The current owner would like to delay the sale for six months, which would represent rental savings of \$10,000. However, the developer estimates that the cost of a six month delay would be \$20,000. After negotiation, suppose that a purchase price of \$475,000 and a six month purchase delay are agreed upon. This agreement is acceptable but not optimal for both parties. In particular, both sides would be better off if the purchase price was increased by \$15,000 and immediate closing instituted. The current owner would receive an additional payment of \$15,000, incur a cost of \$10,000, and have a net gain of \$5,000. Similarly, the developer would pay \$15,000 more for the land but save \$20,000 in delay costs. While this superior result may seem obvious and easily achievable, recognizing such opportunities during a negotiation becomes increasingly difficult as the number and complexity of issues increases.

[Back to top](#)

## 8.8 Negotiation Simulation: An Example

This construction negotiation game simulates a contract negotiation between a utility, "CMG Gas" and a design/construct firm, "Pipeline Constructors, Inc." [4] The negotiation involves only two parties but multiple issues. Participants in the game are assigned to represent one party or the other and to negotiate with a designated partner. In a class setting, numerous negotiating partners are created. The following overview from the CMG Gas participants' instructions describes the setting for the game:

CMG Gas has the opportunity to provide natural gas to an automobile factory under construction. Service will require a new sixteen mile pipeline through farms and light forest. The terrain is hilly with moderate slopes, and equipment access is relatively good. The pipeline is to be buried three feet deep. Construction of the pipeline itself will be contracted to a qualified design/construction firm, while required compression stations and ancillary work will be done by CMG Gas. As project manager for CMG Gas, you are about to enter negotiations with a local contractor, "Pipeline Constructors, Inc." This firm is the only local contractor qualified to handle such a large project. If a suitable contract agreement cannot be reached, then you will have to break off negotiations soon and turn to another company.

The Pipeline Constructors, Inc. instructions offers a similar overview.

To focus the negotiations, the issues to be decided in the contract are already defined:

- **Duration**  
The final contract must specify a required completion date.
- **Penalty for Late Completion**  
The final contract may include a daily penalty for late project completion on the part of the contractor.
- **Bonus for Early Completion**  
The final contract may include a daily bonus for early project completion.
- **Report Format**  
Contractor progress reports will either conform to the traditional CMG Gas format or to a new format proposed by the state.
- **Frequency of Progress Reports**  
Progress reports can be required daily, weekly, bi-weekly or monthly.

- **Conform to Pending Legislation Regarding Pipeline Marking**  
State legislation is pending to require special markings and drawings for pipelines. The parties have to decide whether to conform to this pending legislation.
- **Contract Type**  
The construction contract may be a flat fee, a cost plus a percentage profit, or a guaranteed maximum with cost plus a percentage profit below the maximum.
- **Amount of Flat Fee**  
If the contract is a flat fee, the dollar amount must be specified.
- **Percentage of Profit**  
If the contract involves a percentage profit, then the percentage must be agreed upon.
- **CMG Gas Clerk on Site**  
The contract may specify that a CMG Gas Clerk may be on site and have access to all accounts or that only progress reports are made by Pipeline Constructors, Inc.
- **Penalty for Late Starting Date**  
CMG Gas is responsible for obtaining right-of-way agreements for the new pipeline. The parties may agree to a daily penalty if CMG Gas cannot obtain these agreements.

A final contract requires an agreement on each of these issues, represented on a form signed by both negotiators.

As a further aid, each participant is provided with additional information and a scoring system to indicate the relative desirability of different contract agreements. Additional information includes items such as estimated construction cost and expected duration as well as company policies such as desired reporting formats or work arrangements. This information may be revealed or withheld from the other party depending upon an individual's negotiating strategy. The numerical scoring system includes point totals for different agreements on specific issues, including interactions among the various issues. For example, the amount of points received by Pipeline Constructors, Inc. for a bonus for early completion *increases* as the completion date become *later*. An earlier completion becomes more likely with a later completion date, and hence the probability of receiving a bonus increases, so the resulting point total likewise increases.

The two firms have differing perceptions of the desirability of different agreements. In some cases, their views will be directly conflicting. For example, increases in a flat fee imply greater profits for Pipeline Constructors, Inc. and greater costs for CMG Gas. In some cases, one party may feel strongly about a particular issue, whereas the other is not particularly concerned. For example, CMG Gas may want a clerk on site, while Pipeline Constructors, Inc. may not care. As described in the previous section, these differences in the evaluation of an issue provide opportunities for negotiators. By conceding an unimportant issue to the other party, a negotiator may trade for progress on an issue that is more important to his or her firm. Examples of instructions to the negotiators appear below.

### **Instructions to the Pipelines Constructors, Inc. Representative**

After examining the project site, your company's estimators are convinced that the project can be completed in thirty-six weeks. In bargaining for the duration, keep two things in mind; the longer past thirty-six weeks the contract duration is, the more money that can be made off the "bonuses for being early" and the chances of being late are reduced. That reduces the risk of paying a "penalty for lateness".

Throughout the project the gas company will want progress reports. These reports take time to compile and therefore the fewer you need to submit, the better. In addition, State law dictates that the Required Standard Report be used unless the contractor and the owner agree otherwise. These standard reports are even more time consuming to produce than more traditional reports.

The State Legislature is considering a law that requires accurate drawings and markers of all pipelines by all utilities. You would prefer not to conform to this uncertain set of requirements, but this is negotiable.

What type of contract and the amount your company will be paid are two of the most important issues in negotiations. In the Flat Fee contract, your company will receive an agreed amount from *CMG Gas*. Therefore, when there are any delay or cost overruns, it will be the full responsibility of your company. With this type of contract, your company assumes all the risk and will in turn want a higher price. Your estimators believe a cost and contingency amount of 4,500,000 dollars. You would like a higher fee, of course.

With the Cost Plus Contract, the risk is shared by the gas company and your company. With this type of contract, your company will bill *CMG Gas* for all of its costs, plus a specified percentage of those costs. In this case, cost overruns will be paid by the gas company. Not only does the percentage above cost have to be decided upon but also whether or not your company will allow a Field Clerk from the gas company to be at the job site to monitor reported costs. Whether or not he is around is of no concern to your company since its policy is not to inflate costs. This point can be used as a bargaining weapon.

Finally, your company is worried whether the gas company will obtain the land rights to lay the pipe. Therefore, you should demand a penalty for the potential delay of the project starting date.

### **Instructions to the CMG Gas Company Representative**

In order to satisfy the auto manufacturer, the pipeline must be completed in forty weeks. An earlier completion date will not result in receiving revenue any earlier. Thus, the only reason to bargain for shorter duration is to feel safer about having the project done on time. If the project does exceed the forty week maximum, a penalty will have to be paid to the auto manufacturer. Consequently, if the project exceeds the agreed upon duration, the contractor should pay you a penalty. The penalty for late completion might be related to the project duration. For example, if the duration is agreed to be thirty-six weeks, then the penalty for being late need not be so severe. Also, it is normal that the contractor get a bonus for early completion. Of course, completion before forty weeks doesn't yield any benefit other than your own peace of mind. Try to keep the early bonus as low as possible.

Throughout the project you will want progress reports. The more often these reports are received, the better to monitor the progress. State law dictates that the Required Standard Report be used unless the contractor and the owner agree otherwise. These reports are very detailed and time consuming to review. You would prefer to use the traditional *CMG Gas* reports.

The state legislature is considering a law that requires accurate drawings and markers of all pipelines by all utilities. For this project it will cost an additional \$250,000 to do this now, or \$750,000 to do this when the law is passed.

One of the most important issues is the type of contract, and the amount of be paid. The Flat Fee contract means that *CMG Gas* will pay the contractor a set amount. Therefore, when there are delays and cost overruns, the contractor assumes full responsibility for the individual costs. However, this evasion of risk has to be paid for and results in a higher price. If Flat Fee is chosen, only the contract price is to be determined. Your company's estimators have determined that the project should cost about \$5,000,000.

The Cost Plus Percent contract may be cheaper, but the risk is shared. With this type of contract, the contractor will bill the gas company for all costs, plus a specified percentage of those costs. In this case, cost overruns will be paid by the gas company. If this type of contract is chosen, not only must the profit percentage be chosen, but also whether or not a gas company representative will be allowed on site all of



the time acting as a Field Clerk, to ensure that a proper amount of material and labor is billed. The usual percentage agreed upon is about ten percent.

Contractors also have a concern whether or not they will receive a penalty if the gas right-of-way is not obtained in time to start the project. In this case, *CMG Gas* has already secured the right-of-ways. But, if the penalty is too high, this is a dangerous precedent for future negotiations. However, you might try to use this as a bargaining tool.

### Example 8-8: An example of a negotiated contract

A typical contract resulting from a simulation of the negotiation between *CMG Gas* and *Pipeline Constructors, Inc.* appears in Table 8-6. An agreement with respect to each pre-defined issue is included, and the resulting contract signed by both negotiators.

**TABLE 8-6** Example of a Negotiated Contract between *CMG Gas* and *Pipeline Constructors, Inc.*

Duration	38 weeks
Penalty for Late Completion	\$6,800 per day
Bonus for Early Completion	\$0 per day
Report Format	traditional <i>CMG</i> form
Frequency of Progress Reports	weekly
Conform to Pending Pipeline Marking Legislation	yes
Contract Type	flat fee
Amount of Flat Fee	\$5,050,000
Percentage of Profit	Not applicable
<i>CMG Gas</i> Clerk on Site	yes
Penalty for Late Starting Date	\$3,000 per day
Signed:	
<p><i>CMG Gas</i> Representative</p> <p><i>Pipeline Constructors, Inc.</i></p>	

### Example 8-9: Scoring systems for the negotiated contract games

To measure the performance of the negotiators in the previous example, a scoring system is needed for the representative of *Pipeline Constructors, Inc.* and another scoring system for the representative of *CMG Gas*. These scoring systems for the companies associated with the issues described in Example 8-7 are designated as system A.

In order to make the negotiating game viable for classroom use, another set of instructions for each company is described in this example, and the associated scoring systems for the two companies are designated as System B. In each game play, the instructor may choose a different combination of instructions and negotiating teams, leading to four possible combinations of scoring systems for *Pipeline Constructors, Inc.* and *CMG Gas*. [5]

## Instruction To The Pipeline Constructors, Inc. Representative

In order to help you, your boss has left you with a scoring table for all the issues and alternatives. Two different scoring systems are listed here; you will be assigned to use one or the other. Instructions for scoring system A are included in Section 8.9. The instructions for scoring system B are as follows:

After examining the site, your estimator believes that the project will require 38 weeks. You are happy to conform with any reporting or pipeline marking system, since your computer based project control and design systems can easily produce these submissions. You would prefer to delay the start of the contract as long as possible, since your forces are busy on another job; hence, you do not want to impose a penalty for late start. Try to maximize the amount of points, as they reflect profit brought into your company, or a cost savings. In Parts 3 and 4, be sure to use the project duration agreed upon to calculate your score. Finally, do not discuss your scoring system with the CMG Gas representative; this is proprietary information!

### SCORING FOR PIPELINE CONSTRUCTORS, INC.

**NOTE:** NA means not acceptable and the deal will not be approved by your boss with any of these provisions. also, the alternatives listed are the only ones in the context of this problem; no other alternatives are acceptable.

#### 1. COMPLETION DATE

	System A	System B
Under 36 Weeks	NA	NA
36 weeks	0	NA
37 weeks	+5	-10
38 weeks	+10	0
39 weeks	+20	+10
40 weeks	+40	+20

#### 2. REPORTS

State Standard Report	-20	0
CMG Reports	-5	0

#### 3. PENALTY FOR LATENESS (\$ PER DAY)

	DURATION (WEEKS)				
<b>Scoring System A</b>	<b>36</b>	<b>37</b>	<b>38</b>	<b>39</b>	<b>40</b>
<b>Scoring System B</b>	<b>37</b>	<b>38</b>	<b>39</b>	<b>40</b>	<b>41</b>
0 - 999	-1	-1	-1	0	0
1,000 - 1,999	-2	-2	-2	-1	0
2,000 - 2,999	-4	-3	-3	-2	-1
3,000 - 3,999	-6	-5	-4	-3	-1
4,000 - 4,999	-8	-7	-5	-4	-2
5,000 - 5,999	-11	-9	-7	-5	-2
6,000 - 6,999	-14	-12	-9	-6	-3
7,000 - 7,999	-18	-14	-11	-7	-3
Over 8,000	NA	NA	NA	NA	NA

#### 4. BONUS FOR BEING EARLY (\$ PER DAY)

<b>Scoring System A</b>	<b>36</b>	<b>37</b>	<b>38</b>	<b>39</b>	<b>40</b>
<b>Scoring System B</b>	<b>37</b>	<b>38</b>	<b>39</b>	<b>40</b>	<b>41</b>

0 - 999	0	0	0	0	2
1,000 - 1,999	0	0	2	2	2
2,000 - 2,999	0	2	4	4	4
3,000 - 3,999	1	4	6	6	8
4,000 - 4,999	2	6	8	10	12
5,000 - 5,999	3	8	10	14	16
6,000 - 6,999	4	10	14	18	22
7,000 - 7,999	5	12	18	24	28
8,000 - 8,999	6	14	22	28	36
9,000 - 9,999	7	16	26	32	40
Over 10,000	8	18	30	36	45

## 5. CONFORM TO PENDING LEGISLATION (MARKING PIPELINES)

	<b>A</b>	<b>B</b>
Yes	+5	+10
No	+15	+10

## 6. HOW OFTEN FOR THE PROGRESS REPORTS

	<b>A</b>	<b>B</b>
Daily	NA	0
Weekly	-20	0
Bi-weekly	-10	0
Monthly	-6	0

## 7. CONTRACT TYPE

	<b>A</b>	<b>B</b>
Flat Fee	5	5
Cost + X%	+25	+25

**If Flat Fee do part 8 and skip parts 9 and 10.**

**If Cost + X% do parts 9 and 10 and skip part 8.**

## 8. FLAT FEE (\$)

	<b>A</b>	<b>B</b>
Below 4,500,000	NA	-15 for each 10,000
Over 4,500,000	+1 for each 10,000	+2 for each 10,000

## 9. IF COST PLUS X%

	<b>A</b>	<b>B</b>
Below 6%	NA	NA
6%	+250	NA
7%	+375	+300
8%	+450	+330
9%	+475	+360
10%	+500	+400
11%	+525	+440
12%	+550	+480
13%	+600	+540
14%	+725	+600
Over 14%	+900	+800

## 10. GAS CO. FIELD CLERK ON SITE

	<b>A</b>	<b>B</b>
--	----------	----------

Yes	0	0
No	0	+10

#### 11. PENALTY FOR DELAYED STARTING DATE DUE TO GAS COMPANY ERROR (\$ PER DAY)

	<b>A</b>	<b>B</b>
0 - 499	NA	NA
500 - 1499	-6	-10
1500 - 2499	-4	-7
1500 - 3499	-2	-5
3500 - 4499	-1	-3
4500 - 5499	0	-1
5500 - 6499	+1	0
6500 - 7499	+2	+3
7500 or more	+4	+6

### Instructions to the CMG Gas Company Representative

In order to help you, your boss has left you with a scoring table for all the issues and alternatives. Two different scoring systems are listed here; you will be assigned to use one or the other. Instructions for scoring system A are included in Section 8.9. The instructions for scoring system B are described as follows:

Your contract with the automobile company provides an incentive for completion of the pipeline earlier than 38 weeks and a penalty for completion after 38 weeks. To insure timely completion of the project, you would like to receive detailed project reports as often as possible.

Try to maximize the number of points from the final contract provisions; this corresponds to minimizing costs. Do not discuss your scoring systems with Pipeline Constructors, Inc.

### SCORING SYSTEM FOR CMG GAS

**NOTE:** NA means not acceptable and the deal will not be approved by your boss with any of these provisions. If you can't negotiate a contract, your score will be +450. Also, the alternatives listed are the only ones in the context of this problem no other alternatives are acceptable.

#### 1. DURATION

	POINTS	
	<b>System A</b>	<b>System B</b>
Over 40 weeks	NA	-40
40 weeks	0	-10
39 weeks	+2	+2
38 weeks	+4	+8
37 weeks	+5	+14
0-36 weeks	+6	+14

#### 2. REPORTS

	<b>A</b>	<b>B</b>
Required Standard Report		
"Traditional" CMG Gas Reports	+2	0
	+10	0

## 3. PENALTY FOR LATENESS (\$ PER DAY)

	<b>DURATION (WEEKS)</b>				
<b>Scoring System A</b>	<b>36</b>	<b>37</b>	<b>38</b>	<b>39</b>	<b>40</b>
<b>Scoring System B</b>	<b>38</b>	<b>39</b>	<b>40</b>	<b>41</b>	<b>42</b>
0 - 999	NA	NA	NA	NA	NA
1,000 - 1,999	9	7	6	3	0
2,000 - 2,999	10	9	8	5	2
3,000 - 3,999	11	10	9	6	4
4,000 - 4,999	12	11	10	7	5
5,000 - 5,999	13	12	11	8	6
6,000 - 6,999	14	13	12	9	7
7,000 - 7,999	15	15	13	11	8
8,000 - 8,999	16	15	14	12	9
9,000 - 9,999	17	16	15	13	10
10,000 or more	18	16	15	13	11

## 4. BONUS FOR BEING EARLY (\$ PER DAY)

	<b>A</b>	<b>B</b>
8000 or more	NA	-5
7000 - 7999	+3	-2
6000 - 6999	+6	-1
5000 - 5999	+8	0
4000 - 4999	+10	+5
3000 - 3999	+12	+7
2000 - 2999	+13	+9
1000 - 1999	+14	+13
0 - 999	+15	+17

## 5. CONFORM TO PENDING LEGISLATION (MARKING PIPELINES)

	<b>A</b>	<b>B</b>
Yes	+25	0
No	-25	NA

## 6. HOW OFTEN FOR THE PROGRESS REPORTS

	<b>A</b>	<b>B</b>
Daily	+45	+50
Weekly	+50	+30
Bi-weekly	+30	+10
Monthly	NA	+5

## 7. CONTRACT TYPE

	<b>A</b>	<b>B</b>
Flat Fee	25	25
Cost + X%	0	0

**If Flat Fee do part 8 and skip parts 9 and 10.**

**If Cost + X% do parts 9 and 10 and skip part 8.**

## 8. FLAT FEE (\$)

	<b>A</b>	<b>B</b>
Over 5,000,000	NA	NA
0 - 5,000,000	+1 for each	+1 for each

	10,000 below 5,000,000	10,000 below 5,000,000
<b>9. IF COST PLUS X%</b>		
	<b>A</b>	<b>B</b>
Below 5%	+950	+700
5%	+800	+660
6%	+700	+620
7%	+600	+590
8%	+550	+570
9%	+525	+550
10%	+500	+535
11%	+475	+500
12%	+450	+440
13%	+400	+380
14%	+300	+300
15%	+200	+100
Over 14%	NA	+10

**10. GAS CO. FIELD CLERK ON SITE**

	<b>A</b>	<b>B</b>
Yes	+20	+10
No	+5	0

**11. PENALTY FOR DELAYED STARTING DATE DUE TO UNAVAILABLE RIGHT-OF-WAYS (\$ PER DAY)**

	<b>A</b>	<b>B</b>
0 - 1,999	+10	+3
2,000 - 3,999	+8	+2
4,000 - 5,999	+6	+1
6,000 - 7,999	+4	0
8,000 - 9,999	+2	-10
10,000 or more	NA	-20

[Back to top](#)

## 8.9 Resolution of Contract Disputes

Once a contract is reached, a variety of problems may emerge during the course of work. Disputes may arise over quality of work, over responsibility for delays, over appropriate payments due to changed conditions, or a multitude of other considerations. Resolution of contract disputes is an important task for project managers. The mechanism for contract dispute resolution can be specified in the original contract or, less desirably, decided when a dispute arises.

The most prominent mechanism for dispute resolution is adjudication in a court of law. This process tends to be expensive and time consuming since it involves legal representation and waiting in queues of cases for available court times. Any party to a contract can bring a suit. In adjudication, the dispute is decided by a neutral, third party with no necessary specialized expertise in the disputed subject. After all, it is not a prerequisite for judges to be familiar with construction procedures! Legal procedures are highly structured with rigid, formal rules for presentations and fact finding. On the positive side, legal

adjudication strives for consistency and predictability of results. The results of previous cases are published and can be used as precedents for resolution of new disputes.

Negotiation among the contract parties is a second important dispute resolution mechanism. These negotiations can involve the same sorts of concerns and issues as with the original contracts. Negotiation typically does not involve third parties such as judges. The negotiation process is usually informal, unstructured and relatively inexpensive. If an agreement is not reached between the parties, then adjudication is a possible remedy.

A third dispute resolution mechanism is the resort to arbitration or mediation and conciliation. In these procedures, a third party serves a central role in the resolution. These outside parties are usually chosen by mutual agreement of the parties involved and will have specialized knowledge of the dispute subject. In arbitration, the third party may make a decision which is binding on the participants. In mediation and conciliation, the third party serves only as a facilitator to help the participants reach a mutually acceptable resolution. Like negotiation, these procedures can be informal and unstructured.

Finally, the high cost of adjudication has inspired a series of non-traditional dispute resolution mechanisms that have some of the characteristics of judicial proceedings. These mechanisms include:

- **Private judging** in which the participants hire a third party judge to make a decision,
- **Neutral expert fact-finding** in which a third party with specialized knowledge makes a recommendation, and
- **Mini-trial** in which legal summaries of the participants' positions are presented to a jury comprised of principals of the affected parties.

Some of these procedures may be court sponsored or required for particular types of disputes.

While these various dispute resolution mechanisms involve varying costs, it is important to note that the most important mechanism for reducing costs and problems in dispute resolution is the reasonableness of the initial contract among the parties as well as the competence of the project manager.

[Back to top](#)

## 8.10 References

1. Au, T., R.L. Bostleman and E.W. Parti, "Construction Management Game-Deterministic Model," *Asce Journal of the Construction Division*, Vol. 95, 1969, pp. 25-38.
2. Building Research Advisory Board, *Exploratory Study on Responsibility, Liability and Accountability for Risks in Construction*, National Academy of Sciences, Washington, D.C., 1978.
3. Construction Industry Cost Effectiveness Project, "Contractual Arrangements," Report A-7, The Business Roundtable, New York, October 1982.
4. Dudziak, W. and C. Hendrickson, "A Negotiating Simulation Game," *ASCE Journal of Management in Engineering*, Vol. 4, No. 2, 1988.
5. Graham, P.H., "Owner Management of Risk in Construction Contracts," *Current Practice in Cost Estimating and Cost Control*, Proceedings of an ASCE Conference, Austin, Texas, April 1983, pp. 207-215.
6. Green, E.D., "Getting Out of Court -- Private Resolution of Civil Disputes," *Boston Bar Journal*, May-June 1986, pp. 11-20.
7. Park, William R., *The Strategy of Contracting for Profit*, 2nd Edition, Prentice-Hall, Englewood Cliffs, NJ, 1986.
8. Raiffa, Howard, *The Art and Science of Negotiation*, Harvard University Press, Cambridge, MA,

1982.

9. Walker, N., E.N. Walker and T.K. Rohdenburg, *Legal Pitfalls in Architecture, Engineering and Building Construction*, 2nd Edition, McGraw-Hill Book Co., New York, 1979.

[Back to top](#)

## 8.11 Problems

1. Suppose that in Example 8-5, the terms for the guaranteed maximum cost contract are such that change orders will not be compensated if their total cost is within 3% of the original estimate, but will be compensated in full for the amount beyond 3% of the original estimate. If all other conditions remain unchanged, determine the contractor's profit and the owner's actual payment under this contract for the following conditions of U and C:
  1.  $U = 0$ ,  $C = 6\%E$
  2.  $U = 4\%E$ ,  $C = 6\%E$
  3.  $U = -4\%E$ ,  $C = 6\%E$
2. Suppose that in Example 8-5, the terms of the target estimate contract call for  $N = 0.3$  instead of  $N = 0.5$ , meaning that the contractor will receive 30% of the savings. If all other conditions remain unchanged, determine the contractor's profit and the owner's actual payment under this contract for the given conditions of U and C.
3. Suppose that in Example 8-5, the terms of the cost plus variable percentage contract allow an incentive bonus for early completion and a penalty for late completion of the project. Let D be the number of days early, with negative value denoting D days late. The bonus per days early or the penalty per day late will be T dollars. The agreed formula for owner's payment is:

$$P = R(2E - A + C) + A + C + DT(1 + 0.4C/E)$$

The value of T is set at \$5,000 per day, and the project is completed 30 days behind schedule. If all other conditions remain unchanged, find the contractor's profit and the owner's actual payment under this contract for the given conditions of U and C.

4. Consider a construction project for which the contractor's estimate is \$3,000,000. For various types of contracts,  $R = 10\%$ ,  $R_1 = 3\%$ ,  $R_2 = 1.5\%$ ,  $R_3 = 6\%$  and  $N = 0.6$ . The contractor is not compensated for change orders under the guaranteed maximum cost contract if the total cost for the change order is within 5% (\$150,000) of the original estimate. Determine the contractor's gross profit for each of the seven types of construction contracts for each of the following conditions of U and C:
  1.  $U = 0$ ,  $C = 0$
  2.  $U = 0$ ,  $C = 4\%$   $E = \$120,000$
  3.  $U = 5\%$   $E = \$150,000$ ,  $C = 0$
  4.  $U = 5\%$   $E = \$150,000$ ,  $C = 4\%$   $E = 120,000$
  5.  $U = 2\%$   $E = \$60,000$ ,  $C = 0$
  6.  $U = 2\%$   $E = \$60,000$ ,  $C = 4\%$   $E = 120,000$
5. Using the data in Problem 4, determine the owner's actual payment for each of the seven types of construction contracts for the same conditions of U and C.
6. Suppose that in Problem 4, the terms of the guaranteed maximum cost contract are such that change orders will not be compensated if their total cost is within 3% of the original estimate, but will be compensated in full for the amount beyond 3% of the original estimate. If all conditions



remained unchanged, determine the contractor's profit and the owner's actual payment under this contract for the following conditions of U and C:

1.  $U = 0, \quad C = 5\%E$
  2.  $U = 2\%, \quad C = 5\%E$
  3.  $U = -2\%, \quad C = 5\%E$
7. Suppose that in Problem 4, the terms of the target estimate contract call for  $N = 0.7$  instead of  $N = 0.3$ , meaning that the contractor will receive 70% of the savings. If all other conditions remain unchanged, determine the contractor's profit and the owner's actual payment under this contract for the given conditions of U and C.
  8. Suppose that in Problem 4, the terms of the cost plus variable percentage contract allow an incentive bonus for early completion and a penalty for late completion of the project. Let D be the number of days early, with negative value denoting D days late. The bonus per days early or the penalty per day late will be T dollars. The agreed formula for owner's payment is:

$$P = R(2E - A + C) + A + C + DT(1 + 0.2C/E)$$

The value of T is set at \$ 10,000 per day, and the project is completed 20 days ahead schedule. If all other conditions remain unchanged, find the contractor's profit and the owner's actual payment under this contract for the given conditions of U and C.

9. In playing the construction negotiating game described in Section 8.8, your instructor may choose one of the following combinations of companies and issues leading to different combinations of the scoring systems:

	<u>Pipeline Constructors Inc.</u>	<u>CMG Gas</u>
a.	System A	System A
b.	System A	System B
c.	System B	System A
d.	System B	System B

Since the scoring systems are confidential information, your instructor will not disclose the combination used for the assignment. Your instructor may divide the class into groups of two students, each group acting as negotiators representing the two companies in the game. To keep the game interesting and fair, do not try to find out the scoring system of your negotiating counterpart. To seek insider information is unethical and illegal!

[Back to top](#)

## 8.12 Footnotes

1. These examples are taken directly from A Construction Industry Cost Effectiveness Project Report, "Contractual Arrangements," The Business Roundtable, New York, Appendix D, 1982. Permission to quote this material from the Business Roundtable is gratefully acknowledged. [Back](#)
2. See C.D. Sutliff and J.G. Zack, Jr. "Contract Provisions that Ensure Complete Cost Disclosures", *Cost Engineering*, Vol. 29, No. 10, October 1987, pp. 10-14. [Back](#)
3. *Arkansas Rice Growers v. Alchemy Industries, Inc.*, United States Court of Appeals, Eighth Circuit, 1986. The court decision appears in 797 Federal Reporter, 2d Series, pp. 565-574. [Back](#)

4. This game is further described in W. Dudziak and C. Hendrickson, "A Negotiation Simulation Game," *ASCE Journal of Management in Engineering*, Vol. 4, No. 2, 1988. [Back](#)
5. To undertake this exercise, the instructor needs to divide students into negotiating teams, with each individual assigned scoring system A or B. Negotiators will represent Pipeline Constructors, Inc. or CMG Gas. Negotiating pairs should not be told which scoring system their counterpart is assigned. [Back](#)

[Previous Chapter](#) | [Table of Contents](#) | [Next Chapter](#)

<a href="#">Go Up to Table of Contents</a>	
<a href="#">Go To Chapter 8 (Construction Pricing and Contracting)</a>	<a href="#">Go To Chapter 10 (Fundamental Scheduling Procedures)</a>
<b>Construction Planning</b>	
<a href="#">Basic Concepts in the Development of Construction Plans</a>	
<a href="#">Choice of Technology and Construction Method</a>	
<a href="#">Defining Work Tasks</a>	
<a href="#">Defining Precedence Relationships Among Activities</a>	
<a href="#">Estimating Activity Durations</a>	
<a href="#">Estimating Resource Requirements for Work Activities</a>	
<a href="#">Coding Systems</a>	
<a href="#">References</a>	
<a href="#">Problems</a>	
<a href="#">Footnotes</a>	

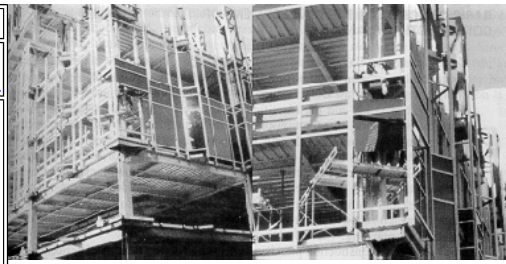

[http://pmbook.ce.cmu.edu/09\\_Construction\\_Planning.html](http://pmbook.ce.cmu.edu/09_Construction_Planning.html)

## 9. Construction Planning

### 9.1 Basic Concepts in the Development of Construction Plans

*Construction planning* is a fundamental and challenging activity in the management and execution of construction projects. It involves the choice of technology, the definition of work tasks, the estimation of the required resources and durations for individual tasks, and the identification of any interactions among the different work tasks. A good construction plan is the basis for developing the budget and the schedule for work. Developing the construction plan is a critical task in the management of construction, even if the plan is not written or otherwise formally recorded. In addition to these technical aspects of construction planning, it may also be necessary to make organizational decisions about the relationships between project participants and even which organizations to include in a project. For example, the extent to which sub-contractors will be used on a project is often determined during construction planning.

Forming a construction plan is a highly challenging task. As Sherlock Holmes noted:

Most people, if you describe a train of events to them, will tell you what the result would be. They can put those events together in their minds, and argue from them that something will come to pass. There are few people, however, who, if you told them a result, would be able to evolve from their own inner consciousness what the steps were which led up to that result. This power is what I mean when I talk of reasoning backward.

[1]

Like a detective, a planner begins with a result (i.e. a facility design) and must synthesize the steps required to yield this result. Essential aspects of construction planning include the *generation* of required activities, *analysis* of the implications of these activities, and *choice* among the various alternative means of performing activities. In contrast to a detective discovering a single train of events, however, construction planners also face the normative problem of choosing the best among numerous alternative plans. Moreover, a detective is faced with an observable result, whereas a planner must imagine the final facility as described in the plans and specifications.

In developing a construction plan, it is common to adopt a primary emphasis on either cost control or on schedule control as illustrated in Fig. 9-1. Some projects are primarily divided into expense categories with associated costs. In these cases, construction planning is cost or expense oriented. Within the categories of expenditure, a distinction is made between costs incurred directly in the performance of an activity and indirectly for the accomplishment of the project. For example, borrowing expenses for project financing and overhead items are commonly treated as indirect costs. For other projects, scheduling of work activities over time is critical and is emphasized in the planning process. In this case, the planner insures that the proper precedences among activities are maintained and that efficient scheduling of the available resources prevails. Traditional scheduling procedures emphasize the maintenance of task precedences (resulting in *critical path scheduling* procedures) or efficient use of resources over time (resulting in *job shop scheduling* procedures). Finally, most complex projects require consideration of both cost and scheduling over time, so that planning, monitoring and record keeping must consider both dimensions. In these cases, the integration of schedule and budget information is a major concern.

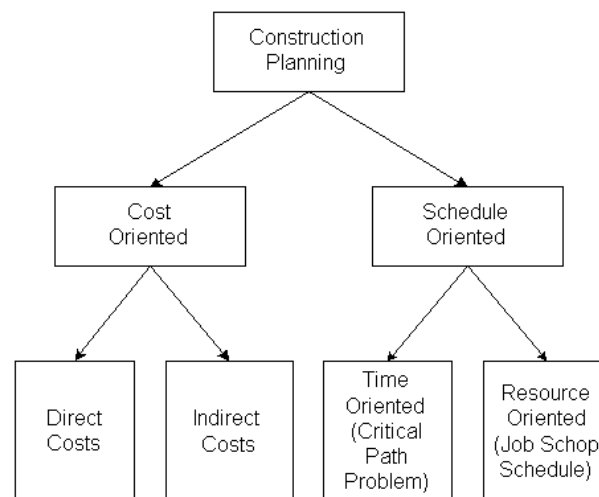

**Figure 9-1** Alternative Emphases in Construction Planning

In this chapter, we shall consider the functional requirements for construction planning such as technology choice, work breakdown, and budgeting. Construction planning is not an activity which is restricted to the period after the award of a contract for construction. It should be an essential activity during the facility design. Also, if problems arise during construction, re-planning is required.

[Back to top](#)

## 9.2 Choice of Technology and Construction Method

As in the development of appropriate alternatives for facility design, choices of appropriate technology and methods for construction are often ill-structured yet critical ingredients in the success of the project. For example, a decision whether to pump or to transport concrete in buckets will directly affect the cost and duration of tasks involved in building construction. A decision between these two alternatives should consider the relative costs, reliabilities, and availability of equipment for the two transport methods. Unfortunately, the exact implications of different methods depend upon numerous considerations for which information may be sketchy during the planning phase, such as the experience and expertise of workers or the particular underground condition at a site.

In selecting among alternative methods and technologies, it may be necessary to formulate a number of construction plans based on alternative methods or assumptions. Once the full plan is available, then the cost, time and reliability impacts of the alternative approaches can be reviewed. This examination of several alternatives is often made explicit in bidding competitions in which several alternative designs may be proposed or *value engineering* for alternative construction methods may be permitted. In this case, potential constructors may wish to prepare plans for each alternative design using the suggested construction method as well as to prepare plans for alternative construction methods which would be proposed as part of the value engineering process.

In forming a construction plan, a useful approach is to simulate the construction process either in the imagination of the planner or with a formal computer based simulation technique. [2] By observing the result, comparisons among different plans or problems with the existing plan can be identified. For example, a decision to use a particular piece of equipment for an operation immediately leads to the question of whether or not there is sufficient access space for the equipment. Three dimensional geometric models in a computer aided design (CAD) system may be helpful in simulating space requirements for operations and for identifying any interferences. Similarly, problems in resource availability identified during the simulation of the construction process might be effectively forestalled by providing additional resources as part of the construction plan.

### Example 9-1: A roadway rehabilitation

An example from a roadway rehabilitation project in Pittsburgh, PA can serve to illustrate the importance of good construction planning and the effect of technology choice. In this project, the decks on overpass bridges as well as the pavement on the highway itself were to be replaced. The initial construction plan was to work outward from each end of the overpass bridges while the highway surface was replaced below the bridges. As a result, access of equipment and concrete trucks to the overpass bridges was a considerable problem. However, the highway work could be staged so that each overpass bridge was accessible from below at prescribed times. By pumping concrete up to the overpass bridge deck from the highway below, costs were reduced and the work was accomplished much more quickly.

### Example 9-2: Laser Leveling

An example of technology choice is the use of laser leveling equipment to improve the productivity of excavation and grading. [3] In these systems, laser surveying equipment is erected on a site so that the relative height of mobile equipment is known exactly. This height measurement is accomplished by flashing a rotating laser light on a level plane across the construction site and observing exactly where the light shines on receptors on mobile equipment such as graders. Since laser light does not disperse appreciably, the height at which the laser shines anywhere on the construction site gives an accurate indication of the height of a receptor on a piece of mobile equipment. In turn, the receptor height can be used to measure the height of a blade, excavator bucket or other piece of equipment. Combined with electro-hydraulic control systems mounted on mobile equipment such as bulldozers, graders and scrapers, the height of excavation and grading blades can be precisely and automatically controlled in these systems. This automation of blade heights has reduced costs in some cases by over 80% and improved quality in the finished product, as measured by the desired amount of excavation or the extent to which a final grade achieves the desired angle. These systems also permit the use of smaller machines and less skilled operators. However, the use of these semi-automated systems require investments in the laser surveying equipment as well as modification to equipment to permit electronic feedback control units. Still, laser leveling appears to be an excellent technological choice in many instances.

[Back to top](#)

## 9.3 Defining Work Tasks

At the same time that the choice of technology and general method are considered, a parallel step in the planning process is to define the various work tasks that must be accomplished. These work tasks represent the necessary framework to permit *scheduling* of construction activities, along with estimating the *resources* required by the individual work tasks, and any necessary *precedences* or required sequence among the tasks. The terms work "tasks" or "activities" are often used interchangeably in construction plans to refer to specific, defined items of work. In job shop or manufacturing terminology, a project would be called a "job" and an activity called an "operation", but the sense of the terms is equivalent. [4] The *scheduling problem* is to determine an appropriate set of activity start time, resource allocations and completion times that will result in completion of the project in a timely and efficient fashion. Construction planning is the necessary fore-runner to scheduling. In this planning, defining work tasks, technology and construction method is typically done either simultaneously or in a series of iterations.

The definition of appropriate work tasks can be a laborious and tedious process, yet it represents the necessary information for application of formal scheduling procedures. Since construction projects can involve thousands of individual work tasks, this definition phase can also be expensive and time consuming. Fortunately, many tasks may be repeated in different parts of the facility or past facility construction plans can be used as general models for new projects. For example, the tasks involved in the construction of a building floor may be repeated with only minor differences for each of the floors in the building. Also, standard definitions and nomenclatures for most tasks exist. As a result, the individual planner defining work tasks does not have to approach each facet of the project entirely from scratch.

While repetition of activities in different locations or reproduction of activities from past projects reduces the work involved, there are very few computer aids for the process of defining activities. Databases and information systems can assist in the storage and recall of the activities associated with past projects as

described in Chapter 14. For the scheduling process itself, numerous computer programs are available. But for the important task of defining activities, reliance on the skill, judgment and experience of the construction planner is likely to continue.

More formally, an *activity* is any subdivision of project tasks. The set of activities defined for a project should be *comprehensive* or completely *exhaustive* so that all necessary work tasks are included in one or more activities. Typically, each design element in the planned facility will have one or more associated project activities. Execution of an activity requires time and resources, including manpower and equipment, as described in the next section. The time required to perform an activity is called the *duration* of the activity. The beginning and the end of activities are signposts or *milestones*, indicating the progress of the project. Occasionally, it is useful to define activities which have no duration to mark important events. For example, receipt of equipment on the construction site may be defined as an activity since other activities would depend upon the equipment availability and the project manager might appreciate formal notice of the arrival. Similarly, receipt of regulatory approvals would also be specially marked in the project plan.

The extent of work involved in any one activity can vary tremendously in construction project plans. Indeed, it is common to begin with fairly coarse definitions of activities and then to further sub-divide tasks as the plan becomes better defined. As a result, the definition of activities evolves during the preparation of the plan. A result of this process is a natural *hierarchy* of activities with large, abstract functional activities repeatedly sub-divided into more and more specific sub-tasks. For example, the problem of placing concrete on site would have sub-activities associated with placing forms, installing reinforcing steel, pouring concrete, finishing the concrete, removing forms and others. Even more specifically, sub-tasks such as removal and cleaning of forms after concrete placement can be defined. Even further, the sub-task "clean concrete forms" could be subdivided into the various operations:

- Transport forms from on-site storage and unload onto the cleaning station.
- Position forms on the cleaning station.
- Wash forms with water.
- Clean concrete debris from the form's surface.
- Coat the form surface with an oil release agent for the next use.
- Unload the form from the cleaning station and transport to the storage location.

This detailed task breakdown of the activity "clean concrete forms" would not generally be done in standard construction planning, but it is essential in the process of programming or designing a *robot* to undertake this activity since the various specific tasks must be well defined for a robot implementation. [\[5\]](#)

It is generally advantageous to introduce an explicit *hierarchy* of work activities for the purpose of simplifying the presentation and development of a schedule. For example, the initial plan might define a single activity associated with "site clearance." Later, this single activity might be sub-divided into "re-locating utilities," "removing vegetation," "grading", etc. However, these activities could continue to be identified as sub-activities under the general activity of "site clearance." This hierarchical structure also facilitates the preparation of summary charts and reports in which detailed operations are combined into aggregate or "super"-activities.

More formally, a hierarchical approach to work task definition decomposes the work activity into component parts in the form of a tree. Higher levels in the tree represent decision nodes or summary activities, while branches in the tree lead to smaller components and work activities. A variety of constraints among the various nodes may be defined or imposed, including precedence relationships among different tasks as defined below. Technology choices may be *decomposed* to decisions made at particular nodes in the tree. For example, choices on plumbing technology might be made without reference to choices for other functional activities.

Of course, numerous different activity hierarchies can be defined for each construction plan. For example, upper level activities might be related to facility components such as foundation elements, and then lower level activity divisions into the required construction operations might be made. Alternatively, upper level divisions might represent general types of activities such as electrical work, while lower work divisions represent the application of these operations to specific facility components. As a third alternative, initial divisions might represent different spatial locations in the planned facility. The choice of a hierarchy depends upon the desired scheme for summarizing work information and on the convenience of the planner. In computerized databases, multiple hierarchies can be stored so that different aggregations or views of the work breakdown structure can be obtained.

The number and detail of the activities in a construction plan is a matter of judgment or convention. Construction plans can easily range between less than a hundred to many thousand defined tasks, depending on the planner's decisions and the scope of the project. If subdivided activities are too refined, the size of the network becomes unwieldy and the cost of planning excessive. Sub-division yields no benefit if reasonably accurate estimates of activity durations and the required resources cannot be made at the detailed work breakdown level. On the other hand, if the specified activities are too coarse, it is impossible to develop realistic schedules and details of resource requirements during the project. More detailed task definitions permit better control and more realistic scheduling. It is useful to define separate work tasks for:

- those activities which involve different resources, or
- those activities which do not require continuous performance.

For example, the activity "prepare and check shop drawings" should be divided into a task for preparation and a task for checking since different individuals are involved in the two tasks and there may be a time lag between preparation and checking.

In practice, the proper level of detail will depend upon the size, importance and difficulty of the project as well as the specific scheduling and accounting procedures which are adopted. However, it is generally the case that most schedules are prepared with too little detail than too much. It is important to keep in mind that task definition will serve as the basis for scheduling, for communicating the construction plan and for construction monitoring. Completion of tasks will also often serve as a basis for progress payments from the owner. Thus, more detailed task definitions can be quite useful. But more detailed task breakdowns are only valuable to the extent that the resources required, durations and activity relationships are realistically estimated for each activity. Providing detailed work task breakdowns is not helpful without a commensurate effort to provide realistic resource requirement estimates. As more powerful, computer-based scheduling and monitoring procedures are introduced, the ease of defining and manipulating tasks will increase, and the number of work tasks can reasonably be expected to expand.

### Example 9-3: Task Definition for a Road Building Project

As an example of construction planning, suppose that we wish to develop a plan for a road construction project including two culverts. [\[6\]](#) Initially, we divide project activities into three categories as shown in Figure 9-2: structures, roadway, and general. This division is based on the major types of design elements to be constructed. Within the roadway work, a further sub-division is into earthwork and pavement. Within these subdivisions, we identify clearing, excavation, filling and finishing (including seeding and sodding) associated with earthwork, and we define watering, compaction and paving sub-activities associated with pavement. Finally, we note that the roadway segment is fairly long, and so individual activities can be defined for different physical segments along the roadway path. In Figure 9-2, we divide each paving and earthwork

activity into activities specific to each of two roadway segments. For the culvert construction, we define the sub-divisions of structural excavation, concreting, and reinforcing. Even more specifically, structural excavation is divided into excavation itself and the required backfill and compaction. Similarly, concreting is divided into placing concrete forms, pouring concrete, stripping forms, and curing the concrete. As a final step in the structural planning, detailed activities are defined for reinforcing each of the two culverts. General work activities are defined for move in, general supervision, and clean up. As a result of this planning, over thirty different detailed activities have been defined.

At the option of the planner, additional activities might also be defined for this project. For example, materials ordering or lane striping might be included as separate activities. It might also be the case that a planner would define a different hierarchy of work breakdowns than that shown in Figure 9-2. For example, placing reinforcement might have been a sub-activity under concreting for culverts. One reason for separating reinforcement placement might be to emphasize the different material and resources required for this activity. Also, the division into separate roadway segments and culverts might have been introduced early in the hierarchy. With all these potential differences, the important aspect is to insure that all necessary activities are included somewhere in the final plan.

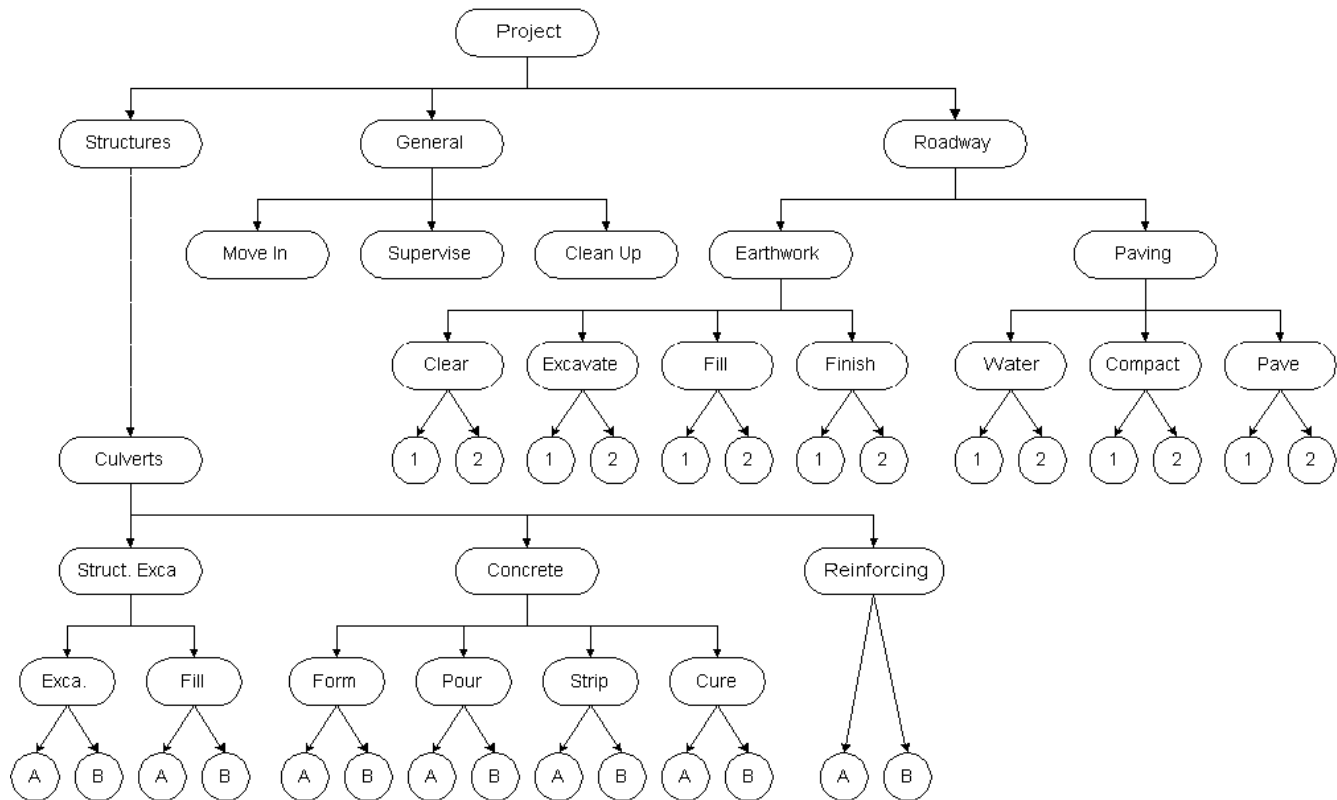

Figure 9-2 Illustrative Hierarchical Activity Divisions for a Roadway Project

[Back to top](#)

### 9.4 Defining Precedence Relationships Among Activities

Once work activities have been defined, the relationships among the activities can be specified. *Precedence* relations between activities signify that the activities must take place in a particular sequence. Numerous natural sequences exist for construction activities due to requirements for structural integrity, regulations, and other technical requirements. For example, design drawings cannot be checked before they are drawn. Diagrammatically, precedence relationships can be illustrated by a *network* or *graph* in which the activities are represented by arrows as in Figure 9-0. The arrows in Figure 9-3 are called *branches* or *links* in the *activity network*, while the circles marking the beginning or end of each arrow are called *nodes* or *events*. In this figure, links represent particular activities, while the nodes represent milestone events.

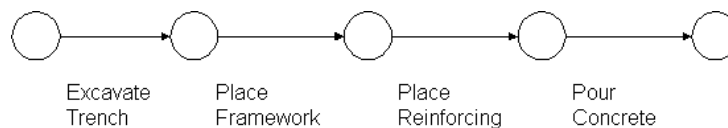
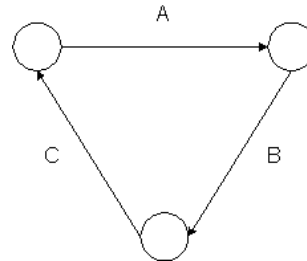

Figure 9-3 Illustrative Set of Four Activities with Precedences

More complicated precedence relationships can also be specified. For example, one activity might not be able to start for several days after the completion of

another activity. As a common example, concrete might have to cure (or set) for several days before formwork is removed. This restriction on the removal of forms activity is called a *lag* between the completion of one activity (i.e., pouring concrete in this case) and the start of another activity (i.e., removing formwork in this case). Many computer based scheduling programs permit the use of a variety of precedence relationships.

Three mistakes should be avoided in specifying predecessor relationships for construction plans. First, a circle of activity precedences will result in an impossible plan. For example, if activity A precedes activity B, activity B precedes activity C, and activity C precedes activity A, then the project can never be started or completed! Figure 9-4 illustrates the resulting activity network. Fortunately, formal scheduling methods and good computer scheduling programs will find any such errors in the logic of the construction plan.



**Figure 9-4** Example of an Impossible Work Plan

Forgetting a necessary precedence relationship can be more insidious. For example, suppose that installation of dry wall should be done prior to floor finishing. Ignoring this precedence relationship may result in both activities being scheduled at the same time. Corrections on the spot may result in increased costs or problems of quality in the completed project. Unfortunately, there are few ways in which precedence omissions can be found other than with checks by knowledgeable managers or by comparison to comparable projects. One other possible but little used mechanism for checking precedences is to conduct a physical or computer based simulation of the construction process and observe any problems.

Finally, it is important to realize that different types of precedence relationships can be defined and that each has different implications for the schedule of activities:

- Some activities have a necessary technical or physical relationship that cannot be superseded. For example, concrete pours cannot proceed before formwork and reinforcement are in place.
- Some activities have a necessary precedence relationship over a continuous space rather than as discrete work task relationships. For example, formwork may be placed in the first part of an excavation trench even as the excavation equipment continues to work further along in the trench. Formwork placement cannot proceed further than the excavation, but the two activities can be started and stopped independently within this constraint.
- Some "precedence relationships" are not technically necessary but are imposed due to implicit decisions within the construction plan. For example, two activities may require the same piece of equipment so a precedence relationship might be defined between the two to insure that they are not scheduled for the same time period. Which activity is scheduled first is arbitrary. As a second example, reversing the sequence of two activities may be technically possible but more expensive. In this case, the precedence relationship is not physically necessary but only applied to reduce costs as perceived at the time of scheduling.

In revising schedules as work proceeds, it is important to realize that different types of precedence relationships have quite different implications for the flexibility and cost of changing the construction plan. Unfortunately, many formal scheduling systems do not possess the capability of indicating this type of flexibility. As a result, the burden is placed upon the manager of making such decisions and insuring realistic and effective schedules. With all the other responsibilities of a project manager, it is no surprise that preparing or revising the formal, computer based construction plan is a low priority to a manager in such cases. Nevertheless, formal construction plans may be essential for good management of complicated projects.

#### **Example 9-4: Precedence Definition for Site Preparation and Foundation Work**

Suppose that a site preparation and concrete slab foundation construction project consists of nine different activities:

- A.** Site clearing (of brush and minor debris),
- B.** Removal of trees,
- C.** General excavation,
- D.** Grading general area,
- E.** Excavation for utility trenches,
- F.** Placing formwork and reinforcement for concrete,
- G.** Installing sewer lines,
- H.** Installing other utilities,
- I.** Pouring concrete.

Activities A (site clearing) and B (tree removal) do not have preceding activities since they depend on none of the other activities. We assume that activities C (general excavation) and D (general grading) are preceded by activity A (site clearing). It might also be the case that the planner wished to delay any excavation until trees were removed, so that B (tree removal) would be a precedent activity to C (general excavation) and D (general grading). Activities E (trench excavation) and F (concrete preparation) cannot begin until the completion of general excavation and tree removal, since they involve subsequent excavation and trench preparation. Activities G (install lines) and H (install utilities) represent installation in the utility trenches and cannot be attempted until the trenches are prepared, so that activity E (trench excavation) is a preceding activity. We also assume that the utilities should not be installed until grading is completed to avoid equipment conflicts, so activity D (general grading) is also preceding activities G (install sewers) and H (install utilities). Finally, activity I (pour concrete) cannot begin until the sewer line is installed and formwork and reinforcement are ready, so activities F and G are preceding. Other utilities may be routed over the slab foundation, so activity H (install utilities) is not necessarily a preceding activity for activity I (pour concrete). The result of our planning are the immediate precedences

shown in Table 9-1.

**TABLE 9-1** Precedence Relations for a Nine-Activity Project Example

Activity	Description	Predecessors
A	Site clearing	---
B	Removal of trees	---
C	General excavation	A
D	Grading general area	A
E	Excavation for utility trenches	B,C
F	Placing formwork and reinforcement for concrete	B,C
G	Installing sewer lines	D,E
H	Installing other utilities	D,E
I	Pouring concrete	F,G

With this information, the next problem is to represent the activities in a network diagram and to determine all the precedence relationships among the activities. One network representation of these nine activities is shown in Figure 9-5, in which the activities appear as branches or links between nodes. The nodes represent milestones of possible beginning and starting times. This representation is called an *activity-on-branch* diagram. Note that an initial event beginning activity is defined (Node 0 in Figure 9-5), while node 5 represents the completion of all activities.

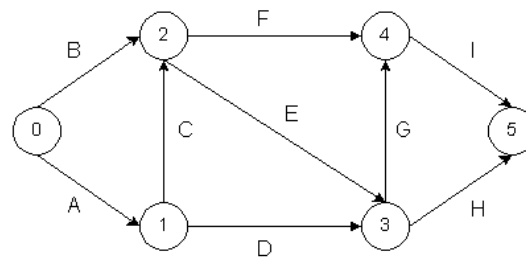

**Figure 9-5** Activity-on-Branch Representation of a Nine Activity Project

Alternatively, the nine activities could be represented by nodes and predecessor relationships by branches or links, as in Figure 9-6. The result is an *activity-on-node* diagram. In Figure 9-6, new activity nodes representing the beginning and the end of construction have been added to mark these important milestones.

These network representations of activities can be very helpful in visualizing the various activities and their relationships for a project. Whether activities are represented as branches (as in Figure 9-5) or as nodes (as in Figure 9-5) is largely a matter of organizational or personal choice. Some considerations in choosing one form or another are discussed in Chapter 10.

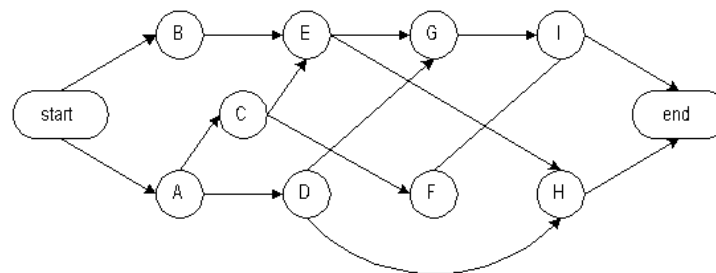

**Figure 9-6** Activity-on-Node Representation of a Nine Activity Project

It is also notable that Table 9-1 lists only the *immediate* predecessor relationships. Clearly, there are other precedence relationships which involve more than one activity. For example, "installing sewer lines" (activity G) cannot be undertaken before "site clearing" (Activity A) is complete since the activity "grading general area" (Activity D) must precede activity G and must follow activity A. Table 9-1 is an *implicit* precedence list since only immediate predecessors are recorded. An explicit predecessor list would include *all* of the preceding activities for activity G. Table 9-2 shows all such predecessor relationships implied by the project plan. This table can be produced by tracing all paths through the network back from a particular activity and can be performed algorithmically. [7] For example, inspecting Figure 9-6 reveals that each activity except for activity B depends upon the completion of activity A.

**TABLE 9-2** All Activity Precedence Relationships for a Nine-Activity Project

Predecessor Activity	Direct Successor Activities	All Successor Activities	All Predecessor Activities
A	C, D	C, D, E, F, G, H, I	A
B	E	E, F, G, H, I	A, B
C	E	E, F, G, H, I	A, B, C
D	F, G, H	F, G, H, I	A, B, C, D
E	G, H	G, H, I	A, B, C, D, E
F	G	G, I	A, B, C, D, E, F
G	I	I	A, B, C, D, E, F, G
H	I	I	A, B, C, D, E, F, G, H
I	end	end	A, B, C, D, E, F, G, H, I



A	C,D	E,F,G,H,I	---
B	E,F	G,H,I	---
C	E,F	G,H,I	A
D	G,H	I	A
E	G,H	I	A,B,C
F	I	---	A,B,C
G	I	---	A,B,C,D,E
H	---	---	A,B,C,D,E
I	---	---	A,B,C,D,E,F,G

[Back to top](#)

## 9.5 Estimating Activity Durations

In most scheduling procedures, each work activity has an associated time duration. These durations are used extensively in preparing a schedule. For example, suppose that the durations shown in Table 9-3 were estimated for the project diagrammed in Figure 9-0. The entire set of activities would then require at least 3 days, since the activities follow one another directly and require a total of  $1.0 + 0.5 + 0.5 + 1.0 = 3$  days. If another activity proceeded in *parallel* with this sequence, the 3 day minimum duration of these four activities is unaffected. More than 3 days would be required for the sequence if there was a delay or a lag between the completion of one activity and the start of another.

**TABLE 9-3** Durations and Predecessors for a Four Activity Project Illustration

Activity	Predecessor	Duration (Days)
Excavate trench	---	1.0
Place formwork	Excavate trench	0.5
Place reinforcing	Place formwork	0.5
Pour concrete	Place reinforcing	1.0

All formal scheduling procedures rely upon estimates of the durations of the various project activities as well as the definitions of the predecessor relationships among tasks. The variability of an activity's duration may also be considered. Formally, the *probability distribution* of an activity's duration as well as the expected or most likely duration may be used in scheduling. A probability distribution indicates the chance that a particular activity duration will occur. In advance of actually doing a particular task, we cannot be certain exactly how long the task will require.

A straightforward approach to the estimation of activity durations is to keep historical records of particular activities and rely on the average durations from this experience in making new duration estimates. Since the scope of activities are unlikely to be identical between different projects, unit productivity rates are typically employed for this purpose. For example, the duration of an activity  $D_{ij}$ , such as concrete formwork assembly might be estimated as:

$$(9.1) \quad D_{ij} = \frac{A_{ij}}{P_{ij} N_{ij}}$$

where  $A_{ij}$  is the required formwork area to assemble (in square yards),  $P_{ij}$  is the average productivity of a standard crew in this task (measured in square yards per hour), and  $N_{ij}$  is the number of crews assigned to the task. In some organizations, unit production time,  $T_{ij}$ , is defined as the time required to complete a unit of work by a standard crew (measured in hours per square yards) is used as a productivity measure such that  $T_{ij}$  is a reciprocal of  $P_{ij}$ .

A formula such as Eq. (9.1) can be used for nearly all construction activities. Typically, the required quantity of work,  $A_{ij}$  is determined from detailed examination of the final facility design. This *quantity-take-off* to obtain the required amounts of materials, volumes, and areas is a very common process in bid preparation by contractors. In some countries, specialized quantity surveyors provide the information on required quantities for all potential contractors and the owner. The number of crews working,  $N_{ij}$ , is decided by the planner. In many cases, the number or amount of resources applied to particular activities may be modified in light of the resulting project plan and schedule. Finally, some estimate of the expected work productivity,  $P_{ij}$  must be provided to apply Equation (9.1). As with cost factors, commercial services can provide average productivity figures for many standard activities of this sort. Historical records in a firm can also provide data for estimation of productivities.

The calculation of a duration as in Equation (9.1) is only an approximation to the actual activity duration for a number of reasons. First, it is usually the case that peculiarities of the project make the accomplishment of a particular activity more or less difficult. For example, access to the forms in a particular location may be difficult; as a result, the productivity of assembling forms may be *lower* than the average value for a particular project. Often, adjustments based on engineering judgment are made to the calculated durations from Equation (9.1) for this reason.

In addition, productivity rates may vary in both systematic and random fashions from the average. An example of systematic variation is the effect of *learning* on productivity. As a crew becomes familiar with an activity and the work habits of the crew, their productivity will typically improve. Figure 9-7 illustrates the type of productivity increase that might occur with experience; this curve is called a *learning curve*. The result is that productivity  $P_{ij}$  is a function of the duration of an activity or project. A common construction example is that the assembly of floors in a building might go faster at higher levels due to improved productivity even though the transportation time up to the active construction area is longer. Again, historical records or subjective adjustments might be made to represent learning curve variations in average productivity. [8]

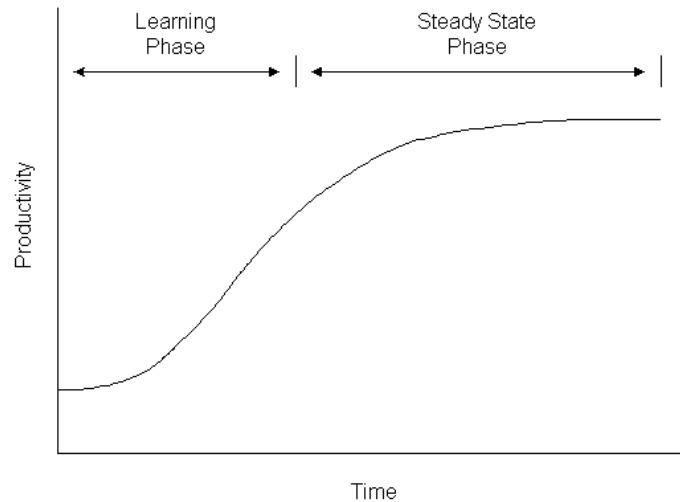

**Figure 9-7** Illustration of Productivity Changes Due to Learning

Random factors will also influence productivity rates and make estimation of activity durations uncertain. For example, a scheduler will typically not know at the time of making the initial schedule how skillful the crew and manager will be that are assigned to a particular project. The productivity of a skilled designer may be many times that of an unskilled engineer. In the absence of specific knowledge, the estimator can only use average values of productivity.

Weather effects are often very important and thus deserve particular attention in estimating durations. Weather has both systematic and random influences on activity durations. Whether or not a rainstorm will come on a particular day is certainly a random effect that will influence the productivity of many activities. However, the likelihood of a rainstorm is likely to vary systematically from one month or one site to the next. Adjustment factors for inclement weather as well as meteorological records can be used to incorporate the effects of weather on durations. As a simple example, an activity might require ten days in perfect weather, but the activity could not proceed in the rain. Furthermore, suppose that rain is expected ten percent of the days in a particular month. In this case, the expected activity duration is eleven days including one expected rain day.

Finally, the use of average productivity factors themselves cause problems in the calculation presented in Equation (9.1). The expected value of the multiplicative reciprocal of a variable is not exactly equal to the reciprocal of the variable's expected value. For example, if productivity on an activity is either six in good weather (i.e.,  $P=6$ ) or two in bad weather (i.e.,  $P=2$ ) and good or bad weather is equally likely, then the expected productivity is  $P = (6)(0.5) + (2)(0.5) = 4$ , and the reciprocal of expected productivity is  $1/4$ . However, the expected reciprocal of productivity is  $E[1/P] = (0.5)/6 + (0.5)/2 = 1/3$ . The reciprocal of expected productivity is 25% less than the expected value of the reciprocal in this case! By representing only two possible productivity values, this example represents an extreme case, but it is always true that the use of average productivity factors in Equation (9.1) will result in *optimistic* estimates of activity durations. The use of actual averages for the reciprocals of productivity or small adjustment factors may be used to correct for this non-linearity problem.

The simple duration calculation shown in Equation (9.1) also assumes an inverse linear relationship between the number of crews assigned to an activity and the total duration of work. While this is a reasonable assumption in situations for which crews can work independently and require no special coordination, it need not always be true. For example, design tasks may be divided among numerous architects and engineers, but delays to insure proper coordination and communication increase as the number of workers increase. As another example, insuring a smooth flow of material to all crews on a site may be increasingly difficult as the number of crews increase. In these latter cases, the relationship between activity duration and the number of crews is unlikely to be inversely proportional as shown in Equation (9.1). As a result, adjustments to the estimated productivity from Equation (9.1) must be made. Alternatively, more complicated functional relationships might be estimated between duration and resources used in the same way that nonlinear preliminary or conceptual cost estimate models are prepared.

One mechanism to formalize the estimation of activity durations is to employ a hierarchical estimation framework. This approach decomposes the estimation problem into component parts in which the higher levels in the hierarchy represent attributes which depend upon the details of lower level adjustments and calculations. For example, Figure 9-8 represents various levels in the estimation of the duration of masonry construction. [9] At the lowest level, the maximum productivity for the activity is estimated based upon general work conditions. Table 9-4 illustrates some possible maximum productivity values that might be employed in this estimation. At the next higher level, adjustments to these maximum productivities are made to account for special site conditions and crew compositions; table 9-5 illustrates some possible adjustment rules. At the highest level, adjustments for overall effects such as weather are introduced. Also shown in Figure 9-8 are nodes to estimate down or unproductive time associated with the masonry construction activity. The formalization of the estimation process illustrated in Figure 9-8 permits the development of computer aids for the estimation process or can serve as a conceptual framework for a human estimator.

**TABLE 9-4** Maximum Productivity Estimates for Masonry Work

Masonry unit size	Condition(s)	Maximum productivity achievable
8 inch block	None	400 units/day/mason
6 inch	Wall is "long"	430 units/day/mason
6 inch	Wall is not "long"	370 units/day/mason
12 inch	Labor is nonunion	300 units/day/mason
4 inch	Wall is "long" Weather is "warm and dry" or high-strength mortar is used	480 units/day/mason

4 inch	Wall is not "long" Weather is "warm and dry" or high-strength mortar is used	430 units/day/mason
4 inch	Wall is "long" Weather is not "warm and dry" or high-strength mortar is not used	370 units/day/mason
4 inch	Wall is not "long" Weather is not "warm and dry" or high-strength mortar is not used	320 units/day/mason
8 inch	There is support from existing wall	1,000 units/day/mason
8 inch	There is no support from existing wall	750 units/day/mason
12 inch	There is support from existing wall	700 units/day/mason
12 inch	There is no support from existing wall	550

**TABLE 9-5** Possible Adjustments to Maximum Productivities for Masonry Construction/caption>

Impact	Condition(s)	Adjustment magnitude (% of maximum)
Crew type	Crew type is nonunion Job is "large"	15%
Crew type	Crew type is union Job is "small"	10%
Supporting labor	There are less than two laborers per crew	20%
Supporting labor	There are more than two masons/laborers	10%
Elevation	Steel frame building with masonry exterior wall has "insufficient" support labor	10%
Elevation	Solid masonry building with work on exterior uses nonunion labor	12%
Visibility	block is not covered	7%
Temperature	Temperature is below 45° F	15%
Temperature	Temperature is above 45° F	10%
Brick texture	bricks are baked high Weather is cold or moist	10%

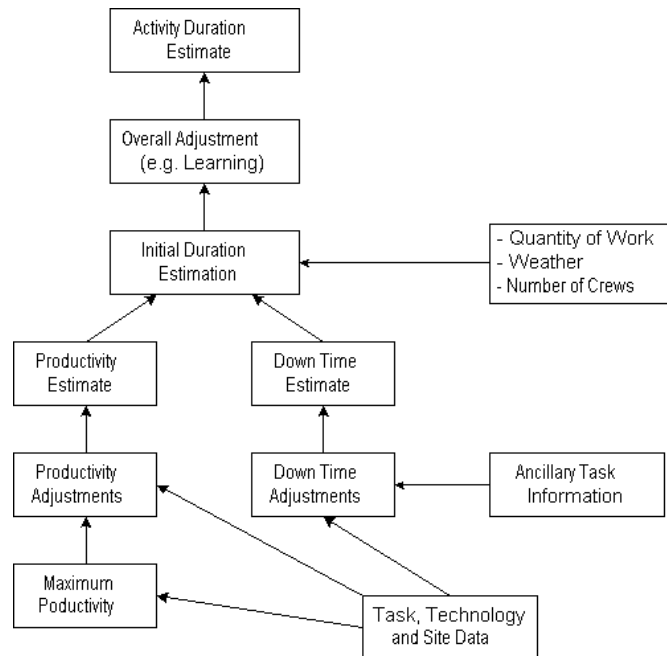

**Figure 9-8** A Hierarchical Estimation Framework for Masonry Construction

In addition to the problem of estimating the expected duration of an activity, some scheduling procedures explicitly consider the uncertainty in activity duration estimates by using the probabilistic distribution of activity durations. That is, the duration of a particular activity is assumed to be a random variable

that is distributed in a particular fashion. For example, an activity duration might be assumed to be distributed as a normal or a beta distributed random variable as illustrated in Figure 9-9. This figure shows the probability or chance of experiencing a particular activity duration based on a probabilistic distribution. The beta distribution is often used to characterize activity durations, since it can have an absolute minimum and an absolute maximum of possible duration times. The normal distribution is a good approximation to the beta distribution in the center of the distribution and is easy to work with, so it is often used as an approximation.

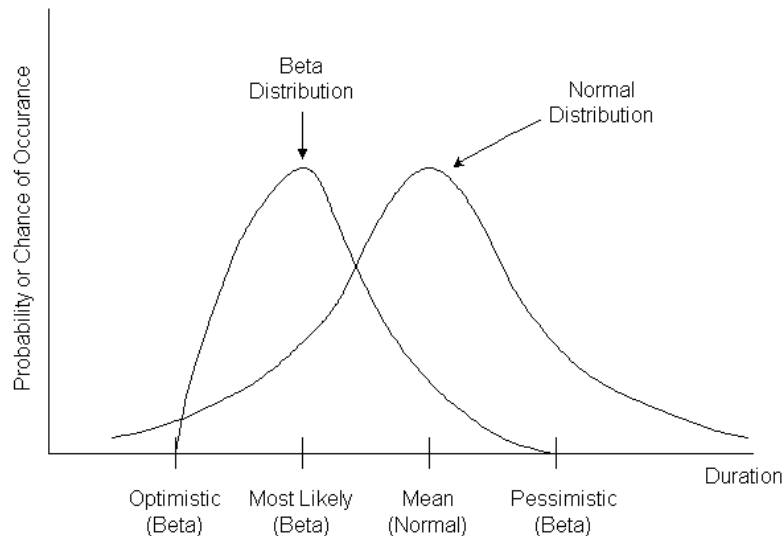

**Figure 9-9** Beta and Normally Distributed Activity Durations

If a standard random variable is used to characterize the distribution of activity durations, then only a few parameters are required to calculate the probability of any particular duration. Still, the estimation problem is increased considerably since more than one parameter is required to characterize most of the probabilistic distribution used to represent activity durations. For the beta distribution, three or four parameters are required depending on its generality, whereas the normal distribution requires two parameters.

As an example, the normal distribution is characterized by two parameters,  $\mu$  and  $\sigma$  representing the average duration and the standard deviation of the duration, respectively. Alternatively, the *variance* of the distribution  $\sigma^2$  could be used to describe or characterize the variability of duration times; the variance is the value of the standard deviation multiplied by itself. From historical data, these two parameters can be estimated as:

$$(9.2) \quad \mu \approx \bar{x} = \sum_{k=1}^n \frac{x_k}{n}$$

$$(9.3) \quad \sigma^2 \approx \sum_{k=1}^n \frac{(x_k - \bar{x})^2}{n-1}$$

where we assume that  $n$  different observations  $x_k$  of the random variable  $x$  are available. This estimation process might be applied to activity durations directly (so that  $x_k$  would be a record of an activity duration  $D_{ij}$  on a past project) or to the estimation of the distribution of productivities (so that  $x_k$  would be a record of the productivity in an activity  $P_i$  on a past project) which, in turn, is used to estimate durations using Equation (9.4). If more accuracy is desired, the estimation equations for mean and standard deviation, Equations (9.2) and (9.3) would be used to estimate the mean and standard deviation of the reciprocal of productivity to avoid non-linear effects. Using estimates of productivities, the standard deviation of activity duration would be calculated as:

$$(9.4) \quad \sigma_{ij} \approx \frac{A_{ij} \sigma_{1/P}}{N_{ij}}$$

where  $\sigma_{1/P}$  is the estimated standard deviation of the reciprocal of productivity that is calculated from Equation (9.3) by substituting  $1/P$  for  $x$ .

[Back to top](#)

## 9.6 Estimating Resource Requirements for Work Activities

In addition to precedence relationships and time durations, *resource requirements* are usually estimated for each activity. Since the work activities defined for

a project are comprehensive, the total resources required for the project are the sum of the resources required for the various activities. By making resource requirement estimates for each activity, the requirements for particular resources during the course of the project can be identified. Potential bottlenecks can thus be identified, and schedule, resource allocation or technology changes made to avoid problems.

Many formal scheduling procedures can incorporate constraints imposed by the availability of particular resources. For example, the unavailability of a specific piece of equipment or crew may prohibit activities from being undertaken at a particular time. Another type of resource is space. A planner typically will schedule only one activity in the same location at the same time. While activities requiring the same space may have no necessary technical precedence, simultaneous work might not be possible. Computational procedures for these various scheduling problems will be described in Chapters 10 and 11. In this section, we shall discuss the estimation of required resources.

The initial problem in estimating resource requirements is to decide the extent and number of resources that might be defined. At a very aggregate level, resources categories might be limited to the amount of labor (measured in man-hours or in dollars), the amount of materials required for an activity, and the total cost of the activity. At this aggregate level, the resource estimates may be useful for purposes of project monitoring and cash flow planning. For example, actual expenditures on an activity can be compared with the estimated required resources to reveal any problems that are being encountered during the course of a project. Monitoring procedures of this sort are described in Chapter 12. However, this aggregate definition of resource use would not reveal bottlenecks associated with particular types of equipment or workers.

More detailed definitions of required resources would include the number and type of both workers and equipment required by an activity as well as the amount and types of materials. Standard resource requirements for particular activities can be recorded and adjusted for the special conditions of particular projects. As a result, the resources types required for particular activities may already be defined. Reliance on historical or standard activity definitions of this type requires a standard coding system for activities.

In making adjustments for the resources required by a particular activity, most of the problems encountered in forming duration estimations described in the previous section are also present. In particular, resources such as labor requirements will vary in proportion to the work productivity,  $P_{ij}$ , used to estimate activity durations in Equation (9.1). Mathematically, a typical estimating equation would be:

(9.5)



where  $R_{ij}^k$  are the resources of type  $k$  required by activity  $ij$ ,  $D_{ij}$  is the duration of activity  $ij$ ,  $N_{ij}$  is the number of standard crews allocated to activity  $ij$ , and  $U_{ij}^k$  is the amount of resource type  $k$  used per standard crew. For example, if an activity required eight hours with two crews assigned and each crew required three workers, the effort would be  $R = 8 \times 2 \times 3 = 48$  labor-hours.

From the planning perspective, the important decisions in estimating resource requirements are to determine the type of technology and equipment to employ and the number of crews to allocate to each task. Clearly, assigning additional crews might result in faster completion of a particular activity. However, additional crews might result in congestion and coordination problems, so that work productivity might decline. Further, completing a particular activity earlier might not result in earlier completion of the entire project, as discussed in Chapter 10.

#### Example 9-5: Resource Requirements for Block Foundations

In placing concrete block foundation walls, a typical crew would consist of three bricklayers and two bricklayer helpers. If sufficient space was available on the site, several crews could work on the same job at the same time, thereby speeding up completion of the activity in proportion to the number of crews. In more restricted sites, multiple crews might interfere with one another. For special considerations such as complicated scaffolding or large blocks (such as twelve inch block), a bricklayer helper for each bricklayer might be required to insure smooth and productive work. In general, standard crew composition depends upon the specific construction task and the equipment or technology employed. These standard crews are then adjusted in response to special characteristics of a particular site.

#### Example 9-6: Pouring Concrete Slabs

For large concrete pours on horizontal slabs, it is important to plan the activity so that the slab for a full block can be completed continuously in a single day. Resources required for pouring the concrete depend upon the technology used. For example, a standard crew for pumping concrete to the slab might include a foreman, five laborers, one finisher, and one equipment operator. Related equipment would be vibrators and the concrete pump itself. For delivering concrete with a chute directly from the delivery truck, the standard crew might consist of a foreman, four laborers and a finisher. The number of crews would be chosen to insure that the desired amount of concrete could be placed in a single day. In addition to the resources involved in the actual placement, it would also be necessary to insure a sufficient number of delivery trucks and availability of the concrete itself.

[Back to top](#)

## 9.7 Coding Systems

One objective in many construction planning efforts is to define the plan within the constraints of a universal *coding system* for identifying activities. Each activity defined for a project would be identified by a pre-defined code specific to that activity. The use of a common nomenclature or identification system is basically motivated by the desire for better integration of organizational efforts and improved information flow. In particular, coding systems are adopted to provide a numbering system to replace verbal descriptions of items. These codes reduce the length or complexity of the information to be recorded. A common coding system within an organization also aids consistency in definitions and categories between projects and among the various parties involved in a project. Common coding systems also aid in the retrieval of historical records of cost, productivity and duration on particular activities. Finally, electronic data storage and retrieval operations are much more efficient with standard coding systems, as described in Chapter 14.

In North America, the most widely used standard coding system for constructed facilities is the MASTERFORMAT system developed by the Construction Specifications Institute (CSI) of the United States and Construction Specifications of Canada. [10] After development of separate systems, this combined system was originally introduced as the Uniform Construction Index (UCI) in 1972 and was subsequently adopted for use by numerous firms, information providers, professional societies and trade organizations. The term MASTERFORMAT was introduced with the 1978 revision of the UCI codes.

MASTERFORMAT provides a standard identification code for nearly all the elements associated with building construction.

MASTERFORMAT involves a hierarchical coding system with multiple levels plus keyword text descriptions of each item. In the numerical coding system, the first two digits represent one of the sixteen divisions for work; a seventeenth division is used to code conditions of the contract for a constructor. In the latest version of the MASTERFORMAT, a third digit is added to indicate a subdivision within each division. Each division is further specified by a three digit extension indicating another level of subdivisions. In many cases, these subdivisions are further divided with an additional three digits to identify more specific work items or materials. For example, the code 16-950-960, "Electrical Equipment Testing" are defined as within Division 16 (Electrical) and Sub-Division 950 (Testing). The keywords "Electrical Equipment Testing" is a standard description of the activity. The seventeen major divisions in the UCI/CSI MASTERFORMAT system are shown in Table 9-6. As an example, site work second level divisions are shown in Table 9-7.

**TABLE 9-6** Major Divisions in the Uniform Construction Index

0 Conditions of the contract	9 Finishes
1 General requirements	10 Specialties
2 Site work	11 Equipment
3 Concrete	12 Furnishings
4 Masonry	13 Special construction
5 Metals	14 Conveying system
6 Wood and plastics	15 Mechanical
7 Thermal and moisture prevention	16 Electrical
8 Doors and windows	

While MASTERFORMAT provides a very useful means of organizing and communicating information, it has some obvious limitations as a complete project coding system. First, more specific information such as location of work or responsible organization might be required for project cost control. Code extensions are then added in addition to the digits in the basic MASTERFORMAT codes. For example, a typical extended code might have the following elements:

0534.02220.21.A.00.cf34

The first four digits indicate the project for this activity; this code refers to an activity on project number 0534. The next five digits refer to the MASTERFORMAT secondary division; referring to Table 9-7, this activity would be 02220 "Excavating, Backfilling and Compacting." The next two digits refer to specific activities defined within this MASTERFORMAT code; the digits 21 in this example might refer to excavation of column footings. The next character refers to the *block* or general area on the site that the activity will take place; in this case, block A is indicated. The digits 00 could be replaced by a code to indicate the responsible organization for the activity. Finally, the characters cf34 refer to the particular design element number for which this excavation is intended; in this case, column footing number 34 is intended. Thus, this activity is to perform the excavation for column footing number 34 in block A on the site. Note that a number of additional activities would be associated with column footing 34, including formwork and concreting. Additional fields in the coding systems might also be added to indicate the responsible crew for this activity or to identify the specific location of the activity on the site (defined, for example, as x, y and z coordinates with respect to a base point).

As a second problem, the MASTERFORMAT system was originally designed for building construction activities, so it is difficult to include various construction activities for other types of facilities or activities associated with planning or design. Different coding systems have been provided by other organizations in particular sub-fields such as power plants or roadways. Nevertheless, MASTERFORMAT provides a useful starting point for organizing information in different construction domains.

In devising organizational codes for project activities, there is a continual tension between adopting systems that are convenient or expedient for one project or for one project manager and systems appropriate for an entire organization. As a general rule, the record keeping and communication advantages of standard systems are excellent arguments for their adoption. Even in small projects, however, ad hoc or haphazard coding systems can lead to problems as the system is revised and extended over time.

**TABLE 9-7** Secondary Divisions in MASTERFORMAT for Site Work [\[11\]](#)

02-010	Subsurface investigation	02-350	Piles and caissons
02-012	Standard penetration tests	02-355	Pile driving
02-016	Seismic investigation	02-360	Driven piles
02-050	Demolition	02-370	Bored/augered piles
02-060	Building demolition	02-380	Caissons
02-070	Selective demolition	02-450	Railroad work
02-075	Concrete removal	02-480	Marine work
02-080	Asbestos removal	02-500	Paving and surfacing
02-100	Site preparation	02-510	Walk, road and parking paving
02-110	Site clearing	02-515	Unit pavers
02-115	Selective clearing	02-525	Curbs
02-120	Structure moving	02-530	Athletic paving and surfacing
02-140	Dewatering	02-540	Synthetic surfacing
02-150	Shoring and underpinning	02-545	Surfacing
02-160	Excavation supporting system	02-550	Highway paving
02-170	Cofferdams	02-560	Airfield paving
02-200	Earthwork	02-575	Pavement repair
02-210	Grading	02-580	Pavement marking
02-220	Excavating, backfilling and compaction	02-600	Piped utility materials
02-230	Base course	02-660	Water distribution
02-240	Soil stabilization	02-680	Fuel distribution
02-250	Vibro-floatation	02-700	Sewage and drainage
02-270	Slope protection		



**Figure 9-10** Illustrative Block Positions for Robot Motion Planning

7. In the previous problem, suppose that switching from the PLACE BLOCK action to the CLEAR BLOCK action or vice versa requires an extra ten seconds. Movements themselves require 8 seconds. What is the sequence of actions of shortest duration to go from position (b) to position (a) in Figure 9-10?
8. Repeat Problem 6 above for the movement from position (a) to position (c) in Figure 9-10.
9. Repeat Problem 7 above for the movement from position (a) to position (c) in Figure 9-10.
10. Suppose that you have an enhanced robot with two additional commands capabilities:
  - o CARRY BLOCKS X-Y to BLOCK Z: This action moves blocks X-Y to the top of block Z. Blocks X-Y may involve any number of blocks as long as X is on the bottom and Y is on the top. This move assumes that Z has a clear top.
  - o CLEAR ALL BLOCK X TO BLOCK Z: This action moves all blocks on top of block X to the top of block Z. If a block Z is not specified, then the blocks are moved to the table top.How do these capabilities change your answer to Problems 6 and 7?
11. How does the additional capability described in Problem 10 change your answer to Problems 8 and ?

[Back to top](#)

## 9.10 Footnotes

1. A.C. Doyle, "A Study in Scarlet," *The Complete Sherlock Holmes*, Doubleday & Co., pg. 83, 1930. [Back](#)
2. See, for example, Paulson, B.C., S.A. Douglas, A. Kalk, A. Touran and G.A. Victor, "Simulation and Analysis of Construction Operations," *ASCE Journal of Technical Topics in Civil Engineering*, 109(2), August, 1983, pp. 89, or Carr, R.I., "Simulation of Construction Project Duration," *ASCE Journal of the Construction Division*, 105(2), June 1979, 117-128. [Back](#)
3. For a description of a laser leveling system, see Paulson, B.C., Jr., "Automation and Robotics for Construction," *ASCE Journal of Construction Engineering and Management*, (111)3, pp. 190-207, Sept. 1985. [Back](#)
4. See Baker, K.R., *Introduction to Sequencing and Scheduling*, John-Wiley and Sons, New York, 1974, for an introduction to scheduling in manufacturing. [Back](#)
5. See Skibniewski, M.J. and C.T. Hendrickson, "Evaluation Method for Robotics Implementation: Application to Concrete Form Cleaning," *Proc. Second Intl. Conf. on Robotics in Construction*, Carnegie-Mellon University, Pittsburgh, PA., 1985, for more detail on the work process design of a concrete form cleaning robot. [Back](#)
6. This example is adapted from Aras, R. and J. Surkis, "PERT and CPM Techniques in Project Management," *ASCE Journal of the Construction Division*, Vol. 90, No. CO1, March, 1964. [Back](#)
7. For a discussion of network reachability and connectivity computational algorithms, see Chapters 2 and 7 in N. Christofides, *Graph Theory: An Algorithmic Approach*, London: Academic Press, 1975, or any other text on graph theory. [Back](#)
8. See H.R. Thomas, C.T. Matthews and J.G. Ward, "Learning Curve Models of Construction Productivity," *ASCE Journal of Construction Engineering and Management*, Vol. 112, No. 2, June 1986, pp. 245-258. [Back](#)
9. For a more extension discussion and description of this estimation procedure, see Hendrickson, C., D. Martinelli, and D. Rehak, "Hierarchical Rule-based Activity Duration Estimation," *ASCE Journal of Construction Engineering and Management*, Vol 113, No. 2, 1987, pp. 288-301. [Back](#)
10. Information on the MASTERFORMAT coding system can be obtained from: The Construction Specifications Institute, 601 Madison St., Alexandria VA 22314. [Back](#)
11. Source: MASTERFORMAT: Master List of Section Titles and Numbers, 1983 Edition, The construction Speculations Institute, Alexandria, VA, 1983. [Back](#)

[Previous Chapter](#) | [Table of Contents](#) | [Next Chapter](#)



<a href="#">Go Up to Table of Contents</a>	
<a href="#">Go To Chapter 9 (Construction Planning)</a>	<a href="#">Go To Chapter 11 (Advanced Scheduling Techniques)</a>
<i>Fundamental Scheduling Procedures</i>	
<a href="#">Relevance of Construction Schedules</a>	
<a href="#">The Critical Path Method</a>	
<a href="#">Calculations for Critical Path Scheduling</a>	
<a href="#">Activity Float and Schedules</a>	
<a href="#">Presenting Project Schedules</a>	
<a href="#">Critical Path Scheduling for Activity-on-Node and with Leads, Lags, and Windows</a>	
<a href="#">Calculations for Scheduling with Leads, Lags and Windows</a>	
<a href="#">Resource Oriented Scheduling</a>	
<a href="#">Scheduling with Resource Constraints and Precedences</a>	
<a href="#">References</a>	
<a href="#">Problems</a>	
<a href="#">Footnotes</a>	

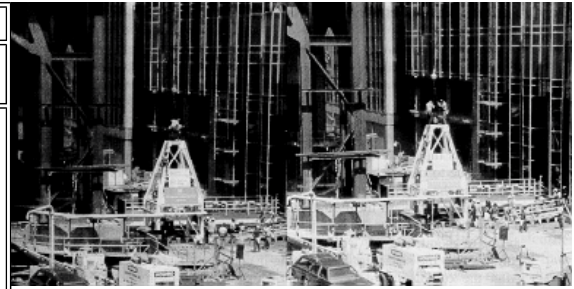

[http://pmbook.ce.cmu.edu/10\\_Fundamental\\_Scheduling\\_Procedures.html](http://pmbook.ce.cmu.edu/10_Fundamental_Scheduling_Procedures.html)

## 10. Fundamental Scheduling Procedures

### 10.1 Relevance of Construction Schedules

In addition to assigning dates to project activities, project scheduling is intended to match the resources of equipment, materials and labor with project work tasks over time. Good scheduling can eliminate problems due to production bottlenecks, facilitate the timely procurement of necessary materials, and otherwise insure the completion of a project as soon as possible. In contrast, poor scheduling can result in considerable waste as laborers and equipment wait for the availability of needed resources or the completion of preceding tasks. Delays in the completion of an entire project due to poor scheduling can also create havoc for owners who are eager to start using the constructed facilities.

Attitudes toward the formal scheduling of projects are often extreme. Many owners require detailed construction schedules to be submitted by contractors as a means of monitoring the work progress. The actual work performed is commonly compared to the schedule to determine if construction is proceeding satisfactorily. After the completion of construction, similar comparisons between the planned schedule and the actual accomplishments may be performed to allocate the liability for project delays due to changes requested by the owner, worker strikes or other unforeseen circumstances.

In contrast to these instances of reliance upon formal schedules, many field supervisors disdain and dislike formal scheduling procedures. In particular, the *critical path method* of scheduling is commonly required by owners and has been taught in universities for over two decades, but is often regarded in the field as irrelevant to actual operations and a time consuming distraction. The result is "seat-of-the-pants" scheduling that can be good or that can result in grossly inefficient schedules and poor productivity. Progressive construction firms use formal scheduling procedures whenever the complexity of work tasks is high and the coordination of different workers is required.

Formal scheduling procedures have become much more common with the advent of personal computers on construction sites and easy-to-use software programs. Sharing schedule information via the Internet has also provided a greater incentive to use formal scheduling methods. Savvy construction supervisors often carry schedule and budget information around with wearable or handheld computers. As a result, the continued development of easy to use computer programs and improved methods of presenting schedules have overcome the practical problems associated with formal scheduling mechanisms. But problems with the use of scheduling techniques will continue until managers understand their proper use and limitations.

A basic distinction exists between *resource oriented* and *time oriented* scheduling techniques. For resource oriented scheduling, the focus is on using and scheduling particular resources in an effective fashion. For example, the project manager's main concern on a high-rise building site might be to insure that cranes are used effectively for moving materials; without effective scheduling in this case, delivery trucks might queue on the ground and workers wait for deliveries on upper floors. For time oriented scheduling, the emphasis is on determining the completion time of the project given the necessary precedence relationships among activities. Hybrid techniques for resource leveling or resource constrained scheduling in the presence of precedence relationships also exist. Most scheduling software is time-oriented, although virtually all of the programs have the capability to introduce resource constraints.

This chapter will introduce the fundamentals of scheduling methods. Our discussion will generally assume that computer based scheduling programs will be applied. Consequently, the wide variety of manual or mechanical scheduling techniques will not be discussed in any detail. These manual methods are not as capable or as convenient as computer based scheduling. With the availability of these computer based scheduling programs, it is important for managers to understand the basic operations performed by scheduling programs. Moreover, even if formal methods are not applied in particular cases, the conceptual framework of formal scheduling methods provides a valuable reference for a manager. Accordingly, examples involving hand calculations will be provided throughout the chapter to facilitate understanding.

[Back to top](#)

### 10.2 The Critical Path Method

The most widely used scheduling technique is the critical path method (CPM) for scheduling, often referred to as *critical path scheduling*. This method calculates the minimum completion time for a project along with the possible start and finish times for the project activities. Indeed, many texts and managers regard critical path scheduling as the only usable and practical scheduling procedure. Computer programs and algorithms for critical path scheduling are widely available and can efficiently handle projects with thousands of activities.

The *critical path* itself represents the set or sequence of predecessor/successor activities which will take the longest time to complete. The duration of the critical path is the sum of the activities' durations along the path. Thus, the critical path can be defined as the longest possible path through the "network" of project activities, as described in Chapter 9. The duration of the critical path represents the minimum time required to complete a project. Any delays along the critical path would imply that additional time would be required to complete the project.

There may be more than one critical path among all the project activities, so completion of the entire project could be delayed by delaying activities along any one of the critical paths. For example, a project consisting of two activities performed in parallel that each require three days would have each activity critical for a completion in three days.

Formally, critical path scheduling assumes that a project has been divided into activities of fixed duration and well defined predecessor relationships. A predecessor relationship implies that one activity must come before another in the schedule. No resource constraints other than those implied by precedence relationships are recognized in the simplest form of critical path scheduling.

To use critical path scheduling in practice, construction planners often represent a *resource constraint* by a precedence relation. A *constraint* is simply a restriction on the options available to a manager, and a *resource constraint* is a constraint deriving from the limited availability of some resource of equipment, material, space or labor. For example, one of two activities requiring the same piece of equipment might be arbitrarily assumed to precede the other activity. This artificial precedence constraint insures that the two activities requiring the same resource will not be scheduled at the same time. Also, most critical path scheduling algorithms impose restrictions on the generality of the activity relationships or network geometries which are used. In essence, these restrictions imply that the construction plan can be represented by a network plan in which activities appear as nodes in a network, as in Figure 9-6. Nodes are numbered, and no two nodes can have the same number or designation. Two nodes are introduced to represent the start and completion of the project itself.

The actual computer representation of the project schedule generally consists of a list of activities along with their associated durations, required resources and predecessor activities. Graphical network representations rather than a list are helpful for visualization of the plan and to insure that mathematical requirements are met. The actual input of the data to a computer program may be accomplished by filling in blanks on a screen menu, reading an existing datafile, or typing data directly to the program with identifiers for the type of information being provided.

With an activity-on-branch network, dummy activities may be introduced for the purposes of providing unique activity designations and maintaining the correct sequence of activities. A *dummy activity* is assumed to have no time duration and can be graphically represented by a dashed line in a network. Several cases in which dummy activities are useful are illustrated in Fig. 10-1. In Fig. 10-1(a), the elimination of activity C would mean that both activities B and D would be identified as being between nodes 1 and 3. However, if a dummy activity X is introduced, as shown in part (b) of the figure, the unique designations for activity B (node 1 to 2) and D (node 1 to 3) will be preserved. Furthermore, if the problem in part (a) is changed so that activity E cannot start until both C and D are completed but that F can start after D alone is completed, the order in the new sequence can be indicated by the addition of a dummy activity Y, as shown in part (c). In general, dummy activities may be necessary to meet the requirements of specific computer scheduling algorithms, but it is important to limit the number of such dummy link insertions to the extent possible.

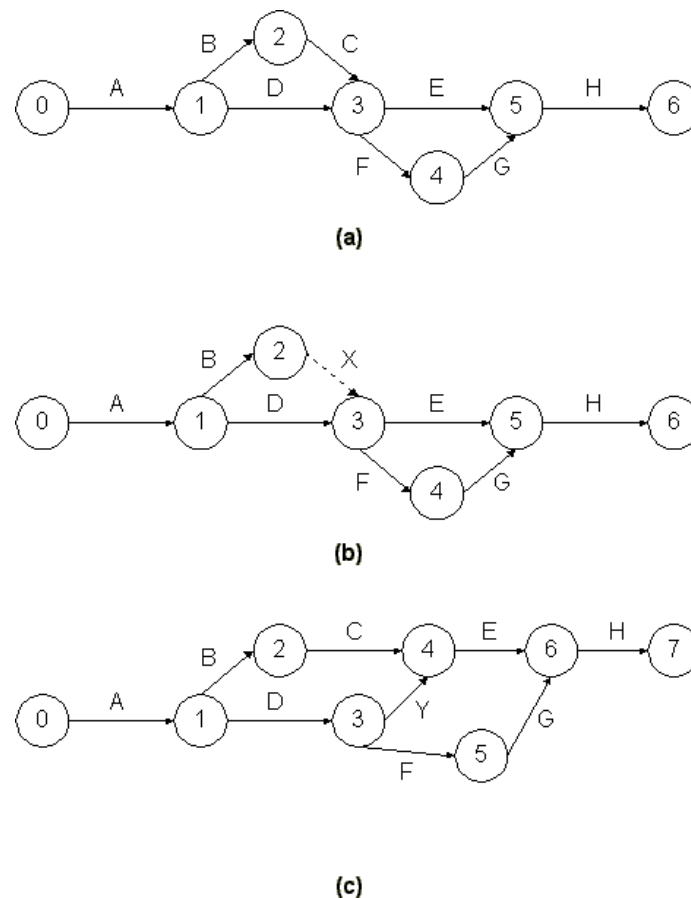

**Figure 10-1** Dummy Activities in a Project Network

Many computer scheduling systems support only one network representation, either activity-on-branch or activity-on-node. A good project manager is familiar with either representation.

#### Example 10-1: Formulating a network diagram

Suppose that we wish to form an activity network for a seven-activity network with the following precedences:

Activity	Predecessors
A	---
B	---
C	A,B
D	C
E	C
F	D
G	D,E

Forming an activity-on-branch network for this set of activities might begin by drawing activities A, B and C as shown in Figure 10-2(a). At this point, we note that two activities (A and B) lie between the same two event nodes; for clarity, we insert a dummy activity X and continue to place other activities as in Figure 10-2(b). Placing activity G in the figure presents a problem, however, since we wish both activity D and activity E to be predecessors. Inserting an additional dummy activity Y along with activity G completes the activity network, as shown in Figure 10-2(c). A comparable activity-on-node representation is shown in Figure 10-3, including project start and finish nodes. Note that dummy activities are not required for expressing precedence relationships in activity-on-node networks.

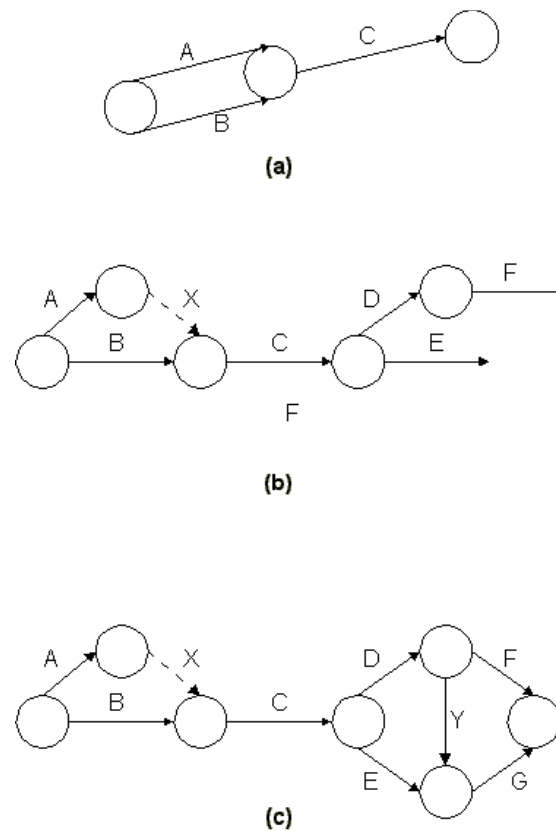

Figure 10-2 An Activity-on-Branch Network for Critical Path Scheduling

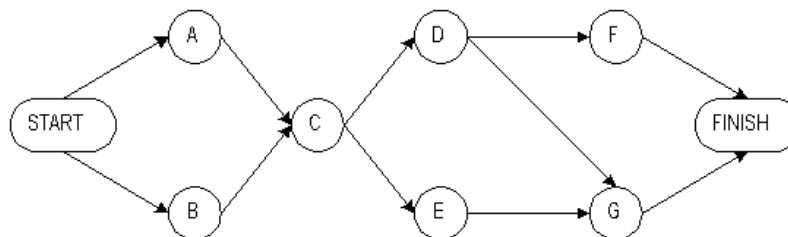

Figure 10-3 An Activity-on-Node Network for Critical Path Scheduling

[Back to top](#)

### 10.3 Calculations for Critical Path Scheduling

With the background provided by the previous sections, we can formulate the critical path scheduling mathematically. We shall present an algorithm or set of instructions for critical path scheduling assuming an activity-on-branch project network. We also assume that all precedences are of a finish-to-start nature, so that a succeeding activity cannot start until the completion of a preceding activity. In a later section, we present a comparable algorithm for activity-on-node representations with multiple precedence types.

Suppose that our project network has  $n+1$  nodes, the initial event being 0 and the last event being  $n$ . Let the time at which node events occur be  $x_1, x_2, \dots, x_n$ , respectively. The start of the project at  $x_0$  will be defined as time 0. Nodal event times must be consistent with activity durations, so that an activity's successor node event time must be larger than an activity's predecessor node event time plus its duration. For an activity defined as starting from event  $i$  and ending at event  $j$ , this relationship can be expressed as the inequality constraint,  $x_j \geq x_i + D_{ij}$  where  $D_{ij}$  is the duration of activity  $(i,j)$ . This same expression can be written for every activity and must hold true in any feasible schedule. Mathematically, then, the critical path scheduling problem is to minimize the time of project completion ( $x_n$ ) subject to the constraints that each node completion event cannot occur until each of the predecessor activities have been completed:

Minimize

$$(10.1) \quad z = x_n$$

subject to

$$x_0 = 0$$

$$x_j - x_i - D_{ij} \geq 0 \text{ for each activity } (i,j)$$

This is a linear programming problem since the objective value to be minimized and each of the constraints is a linear equation. [1]

Rather than solving the critical path scheduling problem with a linear programming algorithm (such as the Simplex method), more efficient techniques are available that take advantage of the network structure of the problem. These solution methods are very efficient with respect to the required computations, so that very large networks can be treated even with personal computers. These methods also give some very useful information about possible activity schedules. The programs can compute the earliest and latest possible starting times for each activity which are consistent with completing the project in the shortest possible time. This calculation is of particular interest for activities which are not on the critical path (or paths), since these activities might be slightly delayed or re-scheduled over time as a manager desires without delaying the entire project.

An efficient solution process for critical path scheduling based upon node labeling is shown in Table 10-1. Three algorithms appear in the table. The *event numbering algorithm* numbers the nodes (or events) of the project such that the beginning event has a lower number than the ending event for each activity. Technically, this algorithm accomplishes a "topological sort" of the activities. The project start node is given number 0. As long as the project activities fulfill the conditions for an activity-on-branch network, this type of numbering system is always possible. Some software packages for critical path scheduling do not have this numbering algorithm programmed, so that the construction project planners must insure that appropriate numbering is done.

**TABLE 10-1** Critical Path Scheduling Algorithms (Activity-on-Branch Representation)

<b>Event Numbering Algorithm</b>
<p><i>Step 1:</i> Give the starting event number 0.  <i>Step 2:</i> Give the next number to any unnumbered event whose predecessor events are each already numbered.            Repeat Step 2 until all events are numbered.</p>
<b>Earliest Event Time Algorithm</b>
<p><i>Step 1:</i> Let <math>E(0) = 0</math>.  <i>Step 2:</i> For <math>j = 1, 2, 3, \dots, n</math> (where <math>n</math> is the last event), let  <math>E(j) = \text{maximum } \{E(i) + D_{ij}\}</math>            where the maximum is computed over all activities <math>(i,j)</math> that have <math>j</math> as the ending event.</p>
<b>Latest Event Time Algorithm</b>
<p><i>Step 1:</i> Let <math>L(n)</math> equal the required completion time of the project.            Note: <math>L(n)</math> must equal or exceed <math>E(n)</math>.  <i>Step 2:</i> For <math>i = n-1, n-2, \dots, 0</math>, let  <math>L(i) = \text{minimum } \{L(j) - D_{ij}\}</math>            where the minimum is computed over all activities <math>(i,j)</math> that have <math>i</math> as the starting event.</p>

The *earliest event time algorithm* computes the earliest possible time,  $E(i)$ , at which each event,  $i$ , in the network can occur. Earliest event times are computed as the maximum of the earliest start times plus activity durations for each of the activities immediately preceding an event. The earliest start time for each activity  $(i,j)$  is equal to the earliest possible time for the preceding event  $E(i)$ :

$$(10.2) \quad ES(i,j) = E(i)$$

The earliest finish time of each activity  $(i,j)$  can be calculated by:

$$(10.3) \quad EF(i,j) = E(i) + D_{ij}$$

Activities are identified in this algorithm by the predecessor node (or event)  $i$  and the successor node  $j$ . The algorithm simply requires that each event in the network should be examined in turn beginning with the project start (node 0).

The *latest event time algorithm* computes the latest possible time,  $L(j)$ , at which each event  $j$  in the network can occur, given the desired completion time of the project,  $L(n)$  for the last event  $n$ . Usually, the desired completion time will be equal to the earliest possible completion time, so that  $E(n) = L(n)$  for the final node  $n$ . The procedure for finding the latest event time is analogous to that for the earliest event time except that the procedure begins with the final event and works backwards through the project activities. Thus, the earliest event time algorithm is often called a *forward pass* through the network, whereas the latest event time algorithm is the *backward pass* through the network. The latest finish time consistent with completion of the project in the desired time frame of  $L(n)$  for each activity  $(i,j)$  is equal to the latest possible time  $L(j)$  for the succeeding event:

$$(10.4) \quad LF(i,j) = L(j)$$

The latest start time of each activity  $(i,j)$  can be calculated by:

$$(10.5) \quad LS(i,j) = L(j) - D_{ij}$$

The earliest start and latest finish times for each event are useful pieces of information in developing a project schedule. Events which have equal earliest and latest times,  $E(i) = L(i)$ , lie on the critical path or paths. An activity  $(i,j)$  is a critical activity if it satisfies all of the following conditions:

$$(10.6) \quad E(i) = L(i)$$

$$(10.7) \quad E(j) = L(j)$$

$$(10.8) \quad E(i) + D_{ij} = L(j)$$

Hence, activities between critical events are also on a critical path as long as the activity's earliest start time equals its latest start time,  $ES(i,j) = LS(i,j)$ . To avoid delaying the project, all the activities on a critical path should begin as soon as possible, so each critical activity  $(i,j)$  must be scheduled to begin at the earliest possible start time,  $E(i)$ .

#### Example 10-2: Critical path scheduling calculations

Consider the network shown in Figure 10-4 in which the project start is given number 0. Then, the only event that has each predecessor numbered is the successor to activity A, so it receives number 1. After this, the only event that has each predecessor numbered is the successor to the two activities B and C, so it receives number 2. The other event numbers resulting from the algorithm are also shown in the figure. For this simple project network, each stage in the numbering process found only one possible event to number at any time. With more than one feasible event to number, the choice of which to number next is arbitrary. For example, if activity C did not exist in the project for Figure 10-4, the successor event for activity A or for activity B could have been numbered 1.

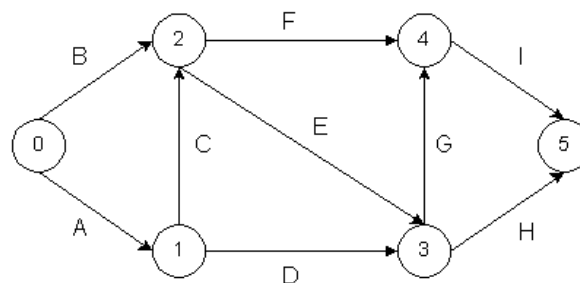

Figure 10-4 A Nine-Activity Project Network

Once the node numbers are established, a good aid for manual scheduling is to draw a small rectangle near each node with two possible entries. The left hand side would contain the earliest time the event could occur, whereas the right hand side would contain the latest time the event could occur without delaying the entire project. Figure 10-5 illustrates a typical box.

E(i)	L(i)
------	------

**Figure 10-5** E(i) and L(i) Display for Hand Calculation of Critical Path for Activity-on-Branch Representation

**TABLE 10-2** Precedence Relations and Durations for a Nine Activity Project Example

Activity	Description	Predecessors	Duration
A	Site clearing	---	4
B	Removal of trees	---	3
C	General excavation	A	8
D	Grading general area	A	7
E	Excavation for trenches	B, C	9
F	Placing formwork and reinforcement for concrete	B, C	12
G	Installing sewer lines	D, E	2
H	Installing other utilities	D, E	5
I	Pouring concrete	F, G	6

For the network in Figure 10-4 with activity durations in Table 10-2, the earliest event time calculations proceed as follows:

$$\begin{aligned}
 \text{Step 1} &\rightarrow & E(0) &= 0 \\
 \text{Step 2} & & & \\
 j = 1 &\rightarrow & E(1) &= \text{Max}\{E(0) + D_{01}\} = \text{Max}\{0 + 4\} = 4 \\
 j = 2 &\rightarrow & E(2) &= \text{Max}\{E(0) + D_{02}; E(1) + D_{12}\} = \text{Max}\{0 + 3; 4 + 8\} = 12 \\
 j = 3 &\rightarrow & E(3) &= \text{Max}\{E(1) + D_{13}; E(2) + D_{23}\} = \text{Max}\{4 + 7; 12 + 9\} = 21 \\
 j = 4 &\rightarrow & E(4) &= \text{Max}\{E(2) + D_{24}; E(3) + D_{34}\} = \text{Max}\{12 + 12; 21 + 2\} = 24 \\
 j = 5 &\rightarrow & E(5) &= \text{Max}\{E(3) + D_{35}; E(4) + D_{45}\} = \text{Max}\{21 + 5; 24 + 6\} = 30
 \end{aligned}$$

Thus, the minimum time required to complete the project is 30 since  $E(5) = 30$ . In this case, each event had at most two predecessors.

For the "backward pass," the latest event time calculations are:

$$\begin{aligned}
 \text{Step 1} &\rightarrow & L(5) &= E(5) = 30 \\
 \text{Step 2} & & & \\
 j = 4 &\rightarrow & L(4) &= \text{Min}\{L(5) - D_{45}\} = \text{Min}\{30 - 6\} = 24 \\
 j = 3 &\rightarrow & L(3) &= \text{Min}\{L(5) - D_{35}; L(4) - D_{34}\} = \text{Min}\{30 - 5; 24 - 2\} = 22 \\
 j = 2 &\rightarrow & L(2) &= \text{Min}\{L(4) - D_{24}; L(3) - D_{23}\} = \text{Min}\{24 - 12; 22 - 9\} = 12 \\
 j = 1 &\rightarrow & L(1) &= \text{Min}\{L(3) - D_{13}; L(2) - D_{12}\} = \text{Min}\{22 - 7; 12 - 8\} = 4 \\
 j = 0 &\rightarrow & L(0) &= \text{Min}\{L(2) - D_{02}; L(1) - D_{01}\} = \text{Min}\{12 - 3; 4 - 4\} = 0
 \end{aligned}$$

In this example,  $E(0) = L(0)$ ,  $E(1) = L(1)$ ,  $E(2) = L(2)$ ,  $E(4) = L(4)$ , and  $E(5) = L(5)$ . As a result, all nodes but node 3 are in the critical path. Activities on the critical path include A (0,1), C (1,2), F (2,4) and I (4,5) as shown in Table 10-3.

**TABLE 10-3** Identification of Activities on the Critical Path for a Nine-Activity Project

Activity	Duration $D_{ij}$	Earliest start time $E(i)=ES(i,j)$	Latest finish time $L(j)=LF(i,j)$	Latest start time $LS(i,j)$
A (0,1)	4	0*	4*	0
B (0,2)	3	0	12	9
C (1,2)	8	4*	12*	4
D (1,3)	7	4	22	15
E (2,3)	9	12	22	13
F (2,4)	12	12*	24*	12
G (3,4)	2	21	24	22
H (3,5)	5	21	30	25
I (4,5)	6	24	30*	24

\*Activity on a critical path since  $E(i) + D_{ij} = L(j)$ .

[Back to top](#)

## 10.4 Activity Float and Schedules

A number of different activity schedules can be developed from the critical path scheduling procedure described in the previous section. An *earliest time* schedule would be developed by starting each activity as soon as possible, at  $ES(i,j)$ . Similarly, a *latest time* schedule would delay the start of each activity as long as possible but still finish the project in the minimum possible time. This late schedule can be developed by setting each activity's start time to  $LS(i,j)$ .

Activities that have different early and late start times (i.e.,  $ES(i,j) < LS(i,j)$ ) can be scheduled to start anytime between  $ES(i,j)$  and  $LS(i,j)$  as shown in Figure 10-6. The concept of *float* is to use part or all of this allowable range to schedule an activity without delaying the completion of the project. An activity that has the earliest time for its predecessor and successor nodes differing by more than its duration possesses a window in which it can be scheduled. That is, if  $E(i) + D_{ij} < L(j)$ , then some float is available in which to schedule this activity.

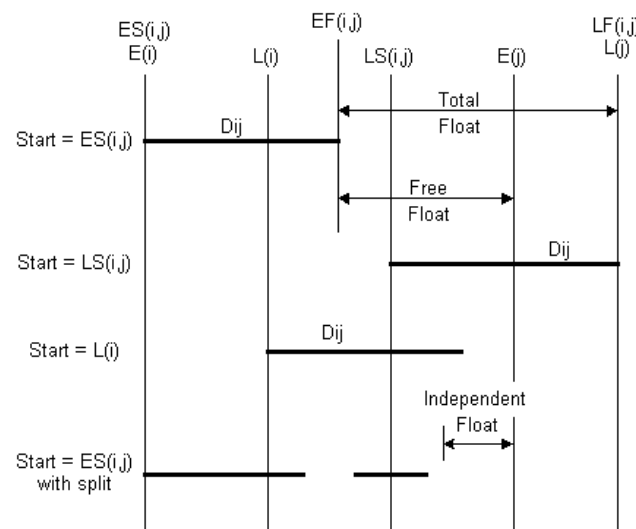

**Figure 10-6** Illustration of Activity Float

Float is a very valuable concept since it represents the scheduling flexibility or "maneuvering room" available to complete particular tasks. Activities on the critical path do not provide any flexibility for scheduling nor leeway in case of problems. For activities with some float, the actual starting time might be chosen to balance work loads over time, to correspond with material deliveries, or to improve the project's cash flow.

Of course, if one activity is allowed to float or change in the schedule, then the amount of float available for other activities may decrease. Three separate categories of float are defined in critical path scheduling:

1. *Free float* is the amount of delay which can be assigned to any one activity without delaying subsequent activities. The free float,  $FF(i,j)$ , associated with activity  $(i,j)$  is:

$$(10.9) \quad FF(i,j) = E(j) - E(i) - D_{ij}$$

2. *Independent float* is the amount of delay which can be assigned to any one activity without delaying subsequent activities or restricting the scheduling of preceding activities. Independent float,  $IF(i,j)$ , for activity  $(i,j)$  is calculated as:

$$(10.10) \quad IF(i,j) = \begin{cases} 0 \\ E(j) - L(i) - D_{ij} \end{cases}$$

3. *Total float* is the maximum amount of delay which can be assigned to any activity without delaying the entire project. The total float,  $TF$



(i,j), for any activity (i,j) is calculated as:

$$(10.11) \quad TF(i,j) = L(j) - E(i) - D_{ij}$$

Each of these "floats" indicates an amount of flexibility associated with an activity. In all cases, total float equals or exceeds free float, while independent float is always less than or equal to free float. Also, any activity on a critical path has all three values of float equal to zero. The converse of this statement is also true, so any activity which has zero total float can be recognized as being on a critical path.

The various categories of activity float are illustrated in Figure 10-6 in which the activity is represented by a bar which can move back and forth in time depending upon its scheduling start. Three possible scheduled starts are shown, corresponding to the cases of starting each activity at the earliest event time,  $E(i)$ , the latest activity start time  $LS(i,j)$ , and at the latest event time  $L(i)$ . The three categories of float can be found directly from this figure. Finally, a fourth bar is included in the figure to illustrate the possibility that an activity might start, be temporarily halted, and then re-start. In this case, the temporary halt was sufficiently short that it was less than the independent float time and thus would not interfere with other activities. Whether or not such work splitting is possible or economical depends upon the nature of the activity.

As shown in Table 10-3, activity D(1,3) has free and independent floats of 10 for the project shown in Figure 10-4. Thus, the start of this activity could be scheduled anytime between time 4 and 14 after the project began without interfering with the schedule of other activities or with the earliest completion time of the project. As the total float of 11 units indicates, the start of activity D could also be delayed until time 15, but this would require that the schedule of other activities be restricted. For example, starting activity D at time 15 would require that activity G would begin as soon as activity D was completed. However, if this schedule was maintained, the overall completion date of the project would not be changed.

### Example 10-3: Critical path for a fabrication project

As another example of critical path scheduling, consider the seven activities associated with the fabrication of a steel component shown in Table 10-4. Figure 10-7 shows the network diagram associated with these seven activities. Note that an additional dummy activity X has been added to insure that the correct precedence relationships are maintained for activity E. A simple rule to observe is that if an activity has more than one immediate predecessor and another activity has at least one but not all of these predecessor activity as a predecessor, a dummy activity will be required to maintain precedence relationships. Thus, in the figure, activity E has activities B and C as predecessors, while activity D has only activity C as a predecessor. Hence, a dummy activity is required. Node numbers have also been added to this figure using the procedure outlined in Table 10-1. Note that the node numbers on nodes 1 and 2 could have been exchanged in this numbering process since after numbering node 0, either node 1 or node 2 could be numbered next.

**TABLE 10-4** Precedences and Durations for a Seven Activity Project

Activity	Description	Predecessors	Duration
A	Preliminary design	---	6
B	Evaluation of design	A	1
C	Contract negotiation	---	8
D	Preparation of fabrication plant	C	5
E	Final design	B, C	9
F	Fabrication of Product	D, E	12
G	Shipment of Product to owner	F	3

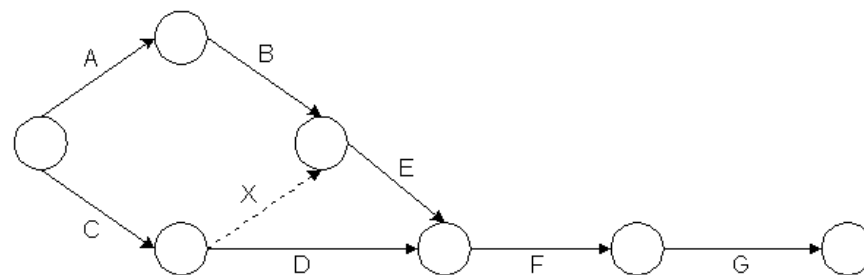

**Figure 10-7** Illustration of a Seven Activity Project Network

The results of the earliest and latest event time algorithms (appearing in Table 10-1) are shown in Table 10-5. The minimum completion time for the project is 32 days. In this small project, all of the event nodes except node 1 are on the critical path. Table 10-6 shows the earliest and latest start times for the various activities including the different categories of float. Activities C,E,F,G

and the dummy activity X are seen to lie on the critical path.

**TABLE 10-5** Event Times for a Seven Activity Project

Node	Earliest Time E(i)	Latest Time L(j)
0	0	0
1	6	7
2	8	8
3	8	8
4	17	17
5	29	29
6	32	32

**TABLE 10-6** Earliest Start, Latest Start and Activity Floats for a Seven Activity Project

Activity	Earliest start time	Latest start time ES(i,j)	Free float LS(i,j)	Independent float	Total float
A (0,1)	0	1	0	0	1
B (1,3)	6	7	1	0	1
C (0,2)	0	0	0	0	0
D (2,4)	8	12	4	4	4
E (3,4)	8	8	0	0	0
F (4,5)	17	17	0	0	0
G (5,6)	29	29	0	0	0
X (2,3)	8	8	0	0	0

[Back to top](#)

## 10.5 Presenting Project Schedules

Communicating the project schedule is a vital ingredient in successful project management. A good presentation will greatly ease the manager's problem of understanding the multitude of activities and their inter-relationships. Moreover, numerous individuals and parties are involved in any project, and they have to understand their assignments. *Graphical* presentations of project schedules are particularly useful since it is much easier to comprehend a graphical display of numerous pieces of information than to sift through a large table of numbers. Early computer scheduling systems were particularly poor in this regard since they produced pages and pages of numbers without aids to the manager for understanding them. A short example appears in Tables 10-5 and 10-6; in practice, a project summary table would be much longer. It is extremely tedious to read a table of activity numbers, durations, schedule times, and floats and thereby gain an understanding and appreciation of a project schedule. In practice, producing diagrams manually has been a common prescription to the lack of automated drafting facilities. Indeed, it has been common to use computer programs to perform critical path scheduling and then to produce bar charts of detailed activity schedules and resource assignments manually. With the availability of computer graphics, the cost and effort of producing graphical presentations has been significantly reduced and the production of presentation aids can be automated.

Network diagrams for projects have already been introduced. These diagrams provide a powerful visualization of the precedences and relationships among the various project activities. They are a basic means of communicating a project plan among the participating planners and project monitors. Project planning is often conducted by producing network representations of greater and greater refinement until the plan is satisfactory.

A useful variation on project network diagrams is to draw a *time-scaled* network. The activity diagrams shown in the previous section were topological networks in that only the relationship between nodes and branches were of interest. The actual diagram could be distorted in any way desired as long as the connections between nodes were not changed. In time-scaled network diagrams, activities on the network are plotted on a horizontal axis measuring the time since project commencement. Figure 10-8 gives an example of a time-scaled activity-on-branch diagram for the nine activity project in Figure 10-4. In this time-scaled diagram, each node is shown at its earliest possible time. By looking over the horizontal axis, the time at which activity can begin can be observed. Obviously, this time scaled diagram is produced as a display after activities are initially scheduled by the critical path method.

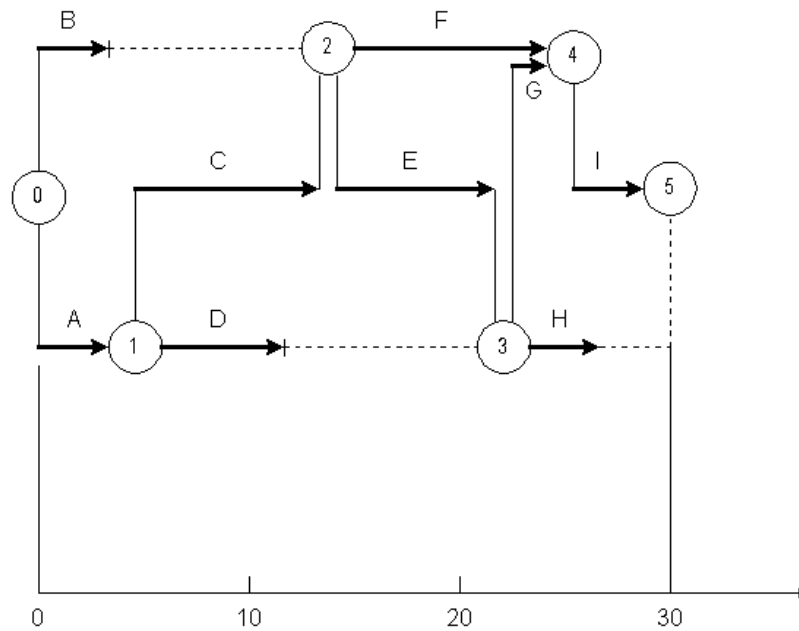

**Figure 10-8** Illustration of a Time Scaled Network Diagram with Nine Activities

Another useful graphical representation tool is a bar or Gantt chart illustrating the scheduled time for each activity. The bar chart lists activities and shows their scheduled start, finish and duration. An illustrative bar chart for the nine activity project appearing in Figure 10-4 is shown in Figure 10-9. Activities are listed in the vertical axis of this figure, while time since project commencement is shown along the horizontal axis. During the course of *monitoring* a project, useful additions to the basic bar chart include a vertical line to indicate the current time plus small marks to indicate the current state of work on each activity. In Figure 10-9, a hypothetical project state after 4 periods is shown. The small "v" marks on each activity represent the current state of each activity.

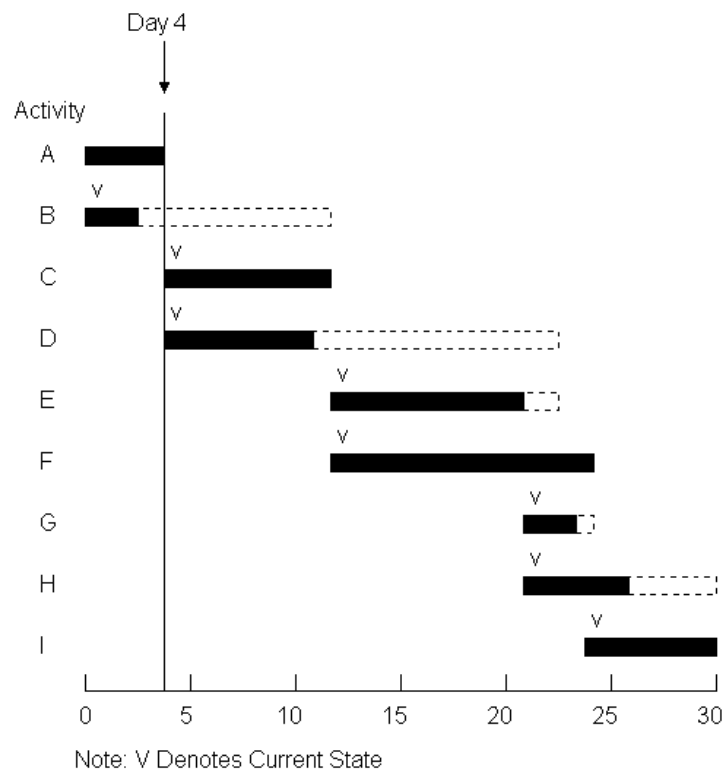

**Figure 10-9** An Example Bar Chart for a Nine Activity Project

Bar charts are particularly helpful for communicating the current state and schedule of activities on a project. As such, they have found wide acceptance as a project representation tool in the field. For planning purposes, bar charts are not as useful since they do not indicate the precedence relationships among activities. Thus, a planner must remember or record separately that a change in one activity's schedule may require changes to successor activities. There have been various schemes for mechanically linking activity bars to represent precedences, but it is now easier to use computer based tools to represent such relationships.

Other graphical representations are also useful in project monitoring. Time and activity graphs are extremely useful in portraying the current status of a project as well as the existence of activity float. For example, Figure 10-10 shows two possible schedules for the nine activity project described in Table 9-1 and shown in the previous figures. The first schedule would occur if each activity was scheduled at its earliest start time,  $ES(i,j)$  consistent with completion of the project in the minimum possible time. With this schedule, Figure 10-10 shows the percent of project activity completed versus time. The second schedule in Figure 10-10 is based on latest possible start times for each activity,  $LS(i,j)$ . The horizontal time difference between the two feasible schedules gives an indication of the extent of possible float. If the project goes according to plan, the actual percentage completion at different times should fall between these curves. In practice, a vertical axis representing cash expenditures rather than percent completed is often used in developing a project representation of this type. For this purpose, activity cost estimates are used in preparing a time versus completion graph. Separate "S-curves" may also be prepared for groups of activities on the same graph, such as separate curves for the design, procurement, foundation or particular sub-contractor activities.

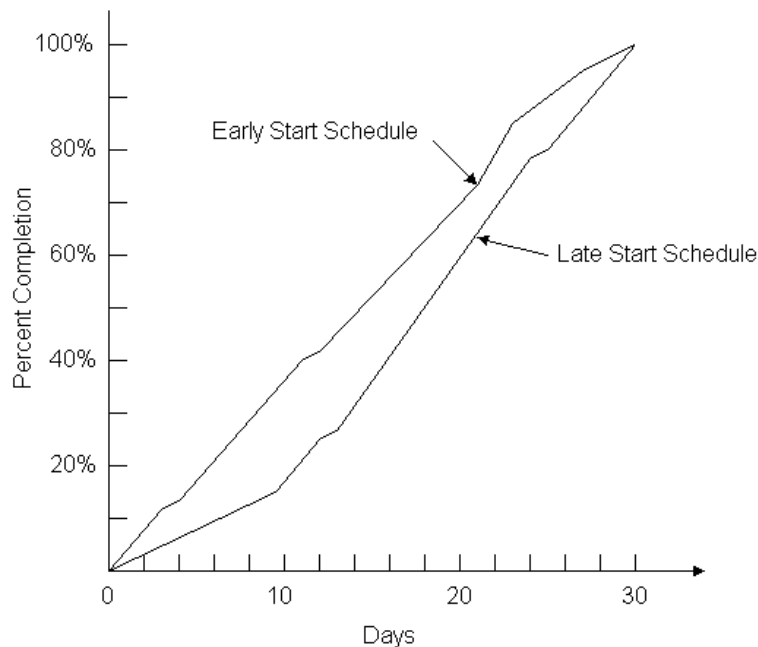
**Figure 10-10** Example of Percentage Completion versus Time for Alternative Schedules with a Nine Activity Project

Time versus completion curves are also useful in project monitoring. Not only the history of the project can be indicated, but the future possibilities for earliest and latest start times. For example, Figure 10-11 illustrates a project that is forty percent complete after eight days for the nine activity example. In this case, the project is well ahead of the original schedule; some activities were completed in less than their expected durations. The possible earliest and latest start time schedules from the current project status are also shown on the figure.

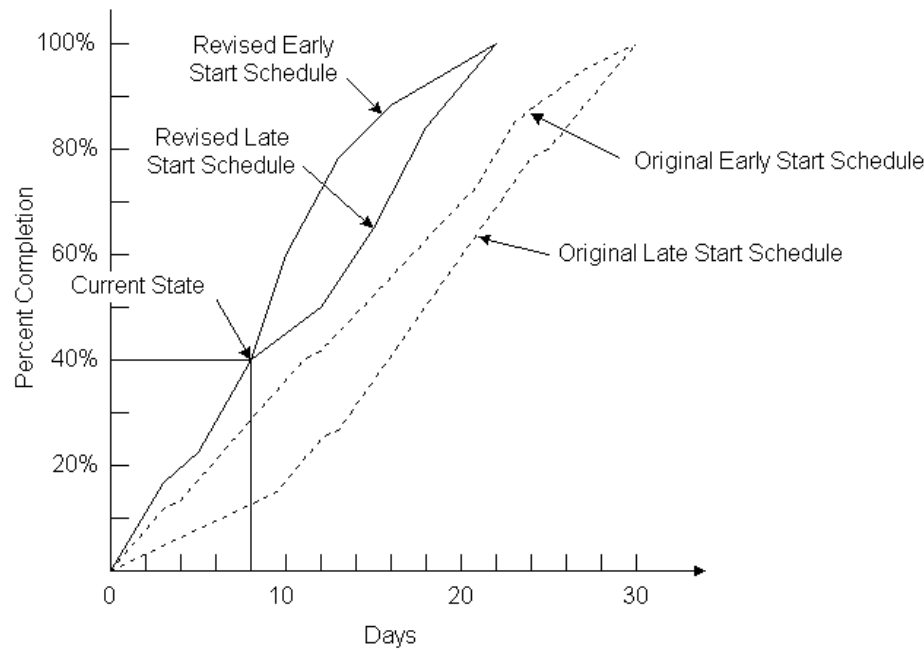

**Figure 10-11** Illustration of Actual Percentage Completion versus Time for a Nine Activity Project Underway

Graphs of resource use over time are also of interest to project planners and managers. An example of resource use is shown in Figure 10-12 for the resource of total employment on the site of a project. This graph is prepared by summing the resource requirements for each activity at each time period for a particular project schedule. With limited resources of some kind, graphs of this type can indicate when the competition for a resource is too large to accommodate; in cases of this kind, resource constrained scheduling may be necessary as described in Section 10.9. Even without fixed resource constraints, a scheduler tries to avoid extreme fluctuations in the demand for labor or other resources since these fluctuations typically incur high costs for training, hiring, transportation, and management. Thus, a planner might alter a schedule through the use of available activity floats so as to level or smooth out the demand for resources. Resource graphs such as Figure 10-12 provide an invaluable indication of the potential trouble spots and the success that a scheduler has in avoiding them.

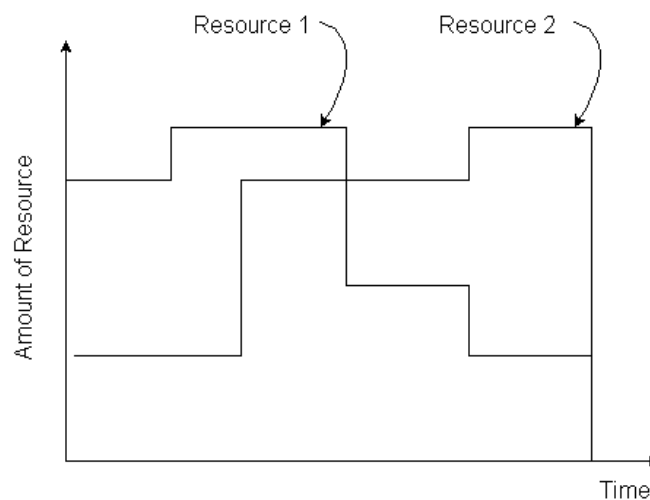
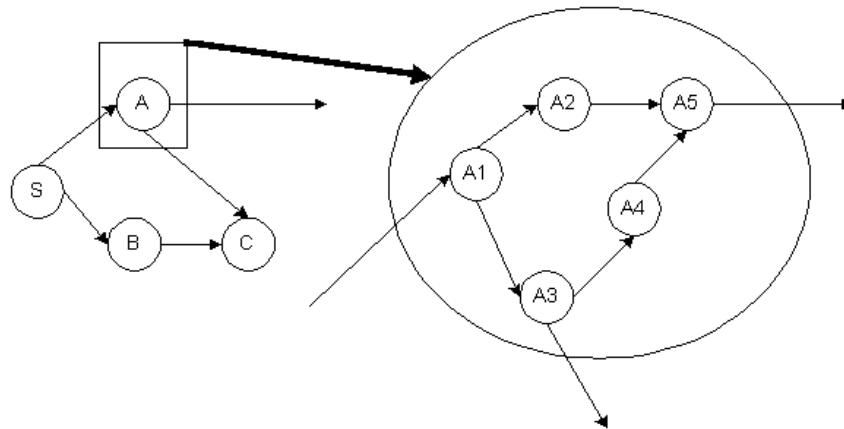

**Figure 10-12** Illustration of Resource Use over Time for a Nine Activity Project

A common difficulty with project network diagrams is that too much information is available for easy presentation in a network. In a project with, say, five hundred activities, drawing activities so that they can be seen without a microscope requires a considerable expanse of paper. A large project might require the wall space in a room to include the entire diagram. On a computer display, a typical restriction is that less than twenty activities can be successfully displayed at the same time. The problem of displaying numerous activities becomes particularly acute when accessory information such as activity identifying numbers or phrases, durations and resources are added to the diagram.

One practical solution to this representation problem is to define sets of activities that can be represented together as a single activity. That is, for display purposes, network diagrams can be produced in which one "activity" would represent a number of real sub-activities. For example, an activity such as "foundation design" might be inserted in summary diagrams. In the actual project plan, this one activity could be subdivided into numerous tasks with their own precedences, durations and other attributes. These sub-groups are sometimes termed *fragnets* for fragments of the full network. The result of this organization is the possibility of producing diagrams that summarize the entire project as well as detailed representations of particular sets of activities. The hierarchy of diagrams can also be introduced to the production of reports so that summary reports for groups of activities can be produced. Thus, detailed representations of particular activities such as plumbing might be prepared with all other activities either omitted or summarized in larger, aggregate activity representations. The CSI/MASTERSPEC activity definition codes described in Chapter 9 provide a widely adopted example of a hierarchical organization of this type. Even if summary reports and diagrams are prepared, the actual scheduling would use detailed activity characteristics, of course.

An example figure of a sub-network appears in Figure 10-13. Summary displays would include only a single node A to represent the set of activities in the sub-network. Note that precedence relationships shown in the master network would have to be interpreted with care since a particular precedence might be due to an activity that would not commence at the start of activity on the sub-network.



**Figure 10-13** Illustration of a Sub-Network in a Summary Diagram

The use of graphical project representations is an important and extremely useful aid to planners and managers. Of course, detailed numerical reports may also be required to check the peculiarities of particular activities. But graphs and diagrams provide an invaluable means of rapidly communicating or understanding a project schedule. With computer based storage of basic project data, graphical output is readily obtainable and should be used whenever possible.

Finally, the scheduling procedure described in Section 10.3 simply counted days from the initial starting point. Practical scheduling programs include a calendar conversion to provide calendar dates for scheduled work as well as the number of days from the initiation of the project. This conversion can be accomplished by establishing a one-to-one correspondence between project dates and calendar dates. For example, project day 2 would be May 4 if the project began at time 0 on May 2 and no holidays intervened. In this calendar conversion, weekends and holidays would be excluded from consideration for scheduling, although the planner might overrule this feature. Also, the number of work shifts or working hours in each day could be defined, to provide consistency with the time units used in estimating activity durations. Project reports and graphs would typically use actual calendar days.

[Back to top](#)

## 10.6 Critical Path Scheduling for Activity-on-Node and with Leads, Lags, and Windows

Performing the critical path scheduling algorithm for activity-on-node representations is only a small variation from the activity-on-branch algorithm presented above. An example of the activity-on-node diagram for a seven activity network is shown in Figure 10-3. Some additional terminology is needed to account for the time delay at a node associated with the task activity. Accordingly, we define:  $ES(i)$  as the earliest start time for activity (and node)  $i$ ,  $EF(i)$  is the earliest finish time for activity (and node)  $i$ ,  $LS(i)$  is the latest start and  $LF(i)$  is the latest finish time for activity (and node)  $i$ . Table 10-7 shows the relevant calculations for the node numbering algorithm, the forward pass and the backward pass calculations.

**TABLE 10-7** Critical Path Scheduling Algorithms (Activity-on-Node Representation)

<b>Activity Numbering Algorithm</b>
<i>Step 1:</i> Give the starting activity number 0.
<i>Step 2:</i> Give the next number to any unnumbered activity whose predecessor activities are each already numbered.
Repeat Step 2 until all activities are numbered.

Forward Pass
<p><i>Step 1:</i> Let <math>E(0) = 0</math>.</p> <p><i>Step 2:</i> For <math>j = 1, 2, 3, \dots, n</math> (where <math>n</math> is the last activity), let  <math>ES(j) = \text{maximum } \{EF(i)\}</math>            where the maximum is computed over all activities (<math>i</math>) that have <math>j</math> as their successor.</p> <p><i>Step 3:</i> <math>EF(j) = ES(j) + D_j</math></p>
Backward Pass
<p><i>Step 1:</i> Let <math>L(n)</math> equal the required completion time of the project.            Note: <math>L(n)</math> must equal or exceed <math>E(n)</math>.</p> <p><i>Step 2:</i> For <math>i = n-1, n-2, \dots, 0</math>, let  <math>LF(i) = \text{minimum } \{LS(j)\}</math>            where the minimum is computed over all activities (<math>j</math>) that have <math>i</math> as their predecessor.</p> <p><i>Step 3:</i> <math>LS(i) = LF(i) - D_i</math></p>

For manual application of the critical path algorithm shown in Table 10-7, it is helpful to draw a square of four entries, representing the  $ES(i)$ ,  $EF(i)$ ,  $LS(i)$  and  $LF(i)$  as shown in Figure 10-14. During the forward pass, the boxes for  $ES(i)$  and  $EF(i)$  are filled in. As an exercise for the reader, the seven activity network in Figure 10-3 can be scheduled. Results should be identical to those obtained for the activity-on-branch calculations.

ES	EF
LS	LF

**Figure 10-14** ES, EF, LS and LF Display for Hand Calculation of Critical Path for Activity-on-Node Representation

Building on the critical path scheduling calculations described in the previous sections, some additional capabilities are useful. Desirable extensions include the definition of allowable *windows* for activities and the introduction of more complicated precedence relationships among activities. For example, a planner may wish to have an activity of removing formwork from a new building component *follow* the concrete pour by some pre-defined lag period to allow setting. This delay would represent a required gap between the completion of a preceding activity and the start of a successor. The scheduling calculations to accommodate these complications will be described in this section. Again, the standard critical path scheduling assumptions of fixed activity durations and unlimited resource availability will be made here, although these assumptions will be relaxed in later sections.

A capability of many scheduling programs is to incorporate types of activity interactions in addition to the straightforward predecessor finish to successor start constraint used in Section 10.3. Incorporation of additional categories of interactions is often called *precedence diagramming*. [2] For example, it may be the case that installing concrete forms in a foundation trench might begin a few hours after the start of the trench excavation. This would be an example of a start-to-start constraint with a lead: the start of the trench-excavation activity would lead the start of the concrete-form-placement activity by a few hours. Eight separate categories of precedence constraints can be defined, representing greater than (leads) or less than (lags) time constraints for each of four different inter-activity relationships. These relationships are summarized in Table 10-8. Typical precedence relationships would be:

- **Direct or finish-to-start leads**

The successor activity cannot start until the preceding activity is complete by at least the prescribed lead time (FS). Thus, the start of a successor activity must exceed the finish of the preceding activity by at least FS.

- **Start-to-start leads**

The successor activity cannot start until work on the preceding activity has been underway by at least the prescribed lead time (SS).

- **Finish-to-finish leadss**

The successor activity must have at least FF periods of work remaining at the completion of the preceding activity.

- **Start-to-finish leads**

The successor activity must have at least SF periods of work remaining at the start of the preceding activity.

While the eight precedence relationships in Table 10-8 are all possible, the most common precedence relationship is the straightforward direct precedence between the finish of a preceding activity and the start of the successor activity with no required gap (so  $FS = 0$ ).

**TABLE 10-8** Eight Possible Activity Precedence Relationships

Relationship	Explanation
<b>Finish-to-start Lead</b>	Latest Finish of Predecessor $\geq$ Earliest Start of Successor + FS
<b>Finish-to-start Lag</b>	Latest Finish of Predecessor $\leq$ Earliest Start of Successor + FS
<b>Start-to-start Lead</b>	Earliest Start of Predecessor $\geq$ Earliest Start of Successor + SS

<b>Start-to-start Lag</b>	Earliest Start of Predecessor $\leq$ Earliest Start of Successor + SS
<b>Finish-to-finish Lead</b>	Latest Finish of Predecessor $\geq$ Earliest Finish of Successor + FF
<b>Finish-to-finish Lag</b>	Latest Finish of Predecessor $\leq$ Earliest Finish of Successor + FF
<b>Start-to-finish Lead</b>	Earliest Start of Predecessor $\geq$ Earliest Finish of Successor + SF
<b>Start-to-finish Lag</b>	Earliest Start of Predecessor $\leq$ Earliest Finish of Successor + SF

The computations with these lead and lag constraints are somewhat more complicated variations on the basic calculations defined in Table 10-1 for critical path scheduling. For example, a start-to-start lead would modify the calculation of the earliest start time to consider whether or not the necessary lead constraint was met:

$$(10.12) \quad E(i) = \max \{ E(i) + D_{ij}; E(i) + SS_{ij} \}$$

where  $SS_{ij}$  represents a start-to-start lead between activity (i,j) and any of the activities starting at event j.

The possibility of interrupting or *splitting* activities into two work segments can be particularly important to insure feasible schedules in the case of numerous lead or lag constraints. With activity splitting, an activity is divided into two sub-activities with a possible gap or idle time between work on the two subactivities. The computations for scheduling treat each sub-activity separately after a split is made. Splitting is performed to reflect available scheduling flexibility or to allow the development of a feasible schedule. For example, splitting may permit scheduling the early finish of a successor activity at a date *later* than the earliest start of the successor plus its duration. In effect, the successor activity is split into two segments with the later segment scheduled to finish after a particular time. Most commonly, this occurs when a constraint involving the finish time of two activities determines the required finish time of the successor. When this situation occurs, it is advantageous to split the successor activity into two so the first part of the successor activity can start earlier but still finish in accordance with the applicable finish-to-finish constraint.

Finally, the definition of activity *windows* can be extremely useful. An activity window defines a permissible period in which a particularly activity may be scheduled. To impose a window constraint, a planner could specify an earliest possible start time for an activity (WES) or a latest possible completion time (WLF). Latest possible starts (WLS) and earliest possible finishes (WEF) might also be imposed. In the extreme, a required start time might be insured by setting the earliest and latest window start times equal (WES = WLS). These window constraints would be in addition to the time constraints imposed by precedence relationships among the various project activities. Window constraints are particularly useful in enforcing milestone completion requirements on project activities. For example, a milestone activity may be defined with no duration but a latest possible completion time. Any activities preceding this milestone activity cannot be scheduled for completion after the milestone date. Window constraints are actually a special case of the other precedence constraints summarized above: windows are constraints in which the predecessor activity is the project start. Thus, an earliest possible start time window (WES) is a start-to-start lead.

One related issue is the selection of an appropriate network representation. Generally, the activity-on-branch representation will lead to a more compact diagram and is also consistent with other engineering network representations of structures or circuits. [3] For example, the nine activities shown in Figure 10-4 result in an activity-on-branch network with six nodes and nine branches. In contrast, the comparable activity-on-node network shown in Figure 9-6 has eleven nodes (with the addition of a node for project start and completion) and fifteen branches. The activity-on-node diagram is more complicated and more difficult to draw, particularly since branches must be drawn crossing one another. Despite this larger size, an important practical reason to select activity-on-node diagrams is that numerous types of precedence relationships are easier to represent in these diagrams. For example, different symbols might be used on each of the branches in Figure 9-6 to represent direct precedences, start-to-start precedences, start-to-finish precedences, etc. Alternatively, the beginning and end points of the precedence links can indicate the type of lead or lag precedence relationship. Another advantage of activity-on-node representations is that the introduction of dummy links as in Figure 10-1 is not required. Either representation can be used for the critical path scheduling computations described earlier. In the absence of lead and lag precedence relationships, it is more common to select the compact activity-on-branch diagram, although a unified model for this purpose is described in Chapter 11. Of course, one reason to pick activity-on-branch or activity-on-node representations is that particular computer scheduling programs available at a site are based on one representation or the other. Since both representations are in common use, project managers should be familiar with either network representation.

Many commercially available computer scheduling programs include the necessary computational procedures to incorporate windows and many of the various precedence relationships described above. Indeed, the term "precedence diagramming" and the calculations associated with these lags seems to have first appeared in the user's manual for a computer scheduling program. [4]

If the construction plan suggests that such complicated lags are important, then these scheduling algorithms should be adopted. In the next section, the various computations associated with critical path scheduling with several types of leads, lags and windows are presented.

[Back to top](#)

## 10.7 Calculations for Scheduling with Leads, Lags and Windows

Table 10-9 contains an algorithmic description of the calculations required for critical path scheduling with leads, lags and windows. This



description assumes an *activity-on-node* project network representation, since this representation is much easier to use with complicated precedence relationships. The possible precedence relationships accommodated by the procedure contained in Table 10-9 are finish-to-start leads, start-to-start leads, finish-to-finish lags and start-to-finish lags. Windows for earliest starts or latest finishes are also accommodated. Incorporating other precedence and window types in a scheduling procedure is also possible as described in Chapter 11. With an activity-on-node representation, we assume that an initiation and a termination activity are included to mark the beginning and end of the project. The set of procedures described in Table 10-9 does not provide for automatic splitting of activities.

**TABLE 10-9** Critical Path Scheduling Algorithms with Leads, Lags and Windows (Activity-on-Node Representations)

<b>Activity Numbering Algorithm</b>
<p><i>Step 1:</i> Give the starting activity number 0.  <i>Step 2:</i> Give the next number to any unnumbered activity whose predecessor activities are each already numbered.  Repeat Step 2 until all activities are numbered.</p>
<b>Forward Pass Computations</b>
<p><i>Step 0:</i> Set the earliest start and the earliest finish of the initial activity to zero:  <math>(ES(0) = EF(0) = 0)</math>.  Repeat the following steps for each activity <math>k = 0, 1, 2, \dots, m</math>:  <i>Step 1:</i> Compute the earliest start time <math>(ES(k))</math> of activity <math>k</math>:  <math>ES(k) = \text{Maximum } \{0; WES(k) \text{ for the earliest start window time, } WEF(k) - D(k) \text{ for the earliest finish window time; } EF(i) + FS(i,k) \text{ for each preceding activity with a F-S constraint; } ES(i) + SS(i,k) \text{ for each preceding activity with a S-S constraint; } EF(i) + FF(i,k) - D(k) \text{ for each preceding activity with a F-F constraint; } ES(i) + SF(i,k) - D(k) \text{ for each preceding activity with a S-F constraint.}\}</math>  <i>Step 2:</i> Compute the earliest finish time <math>EF(k)</math> of activity <math>k</math>:  <math>EF(k) = ES(k) + D(k)</math>.</p>
<b>Backward Pass Computations</b>
<p><i>Step 0:</i> Set the latest finish and latest start of the terminal activity to the early start time:  <math>LF(m) = LS(m) = ES(m) = EF(m)</math>  Repeat the following steps for each activity in reverse order, <math>k = m-1, m-2, \dots, 2, 1, 0</math>:  <i>Step 1:</i> Compute the latest finish time for activity <math>k</math>:  <math>LF(k) = \text{Min} \{ LF(m), WLF(k) \text{ for the latest finish window time; } WLS(k) + D(k) \text{ for the latest start window time; } LS(j) - FS(k,j) \text{ for each succeeding activity with a F-S constraint; } LF(j) - FF(k,j) \text{ for each succeeding activity with a FF constraint; } LS(j) - SS(k,j) + D(k) \text{ for each succeeding activity with a SS constraint; } LF(j) - SF(k,j) + D(k) \text{ for each succeeding activity with a SF constraint.}\}</math>  <i>Step 2:</i> Compute the latest start time for activity <math>k</math>:  <math>LS(k) = LF(k) - D(k)</math></p>

The first step in the scheduling algorithm is to sort activities such that no higher numbered activity precedes a lower numbered activity. With numbered activities, durations can be denoted  $D(k)$ , where  $k$  is the number of an activity. Other activity information can also be referenced by the activity number. Note that node events used in *activity-on-branch* representations are not required in this case.

The forward pass calculations compute an earliest start time  $(ES(k))$  and an earliest finish time  $(EF(k))$  for each activity in turn (Table 10-9). In computing the earliest start time of an activity  $k$ , the earliest start window time (WES), the earliest finish window time (WEF), and each of the various precedence relationships must be considered. Constraints on finish times are included by identifying minimum finish times and then subtracting the activity duration. A default earliest start time of day 0 is also insured for all activities. A second step in the procedure is to identify each activity's earliest finish time  $(EF(k))$ .

The backward pass calculations proceed in a manner very similar to those of the forward pass (Table 10-9). In the backward pass, the latest finish and the latest start times for each activity are calculated. In computing the latest finish time, the latest start time is identified which is consistent with precedence constraints on an activity's starting time. This computation requires a minimization over applicable window times and all successor activities. A check for a feasible activity schedule can also be imposed at this point: if the late start time is less than the early start time  $(LS(k) < ES(k))$ , then the activity schedule is not possible.

The result of the forward and backward pass calculations are the earliest start time, the latest start time, the earliest finish time, and the latest finish time for each activity. The activity float is computed as the latest start time less the earliest start time. Note that window constraints may be instrumental in setting the amount of float, so that activities without any float may either lie on the critical path or be constrained by an allowable window.

To consider the possibility of activity splitting, the various formulas for the forward and backward passes in Table 10-9 must be modified. For example, in considering the possibility of activity splitting due to start-to-start lead (SS), it is important to ensure that the preceding activity has been underway for at least the required lead period. If the preceding activity was split and the first sub-activity was not underway for a sufficiently long period, then the following activity cannot start until the first plus the second sub-activities have been underway for a period equal to  $SS(i,k)$ . Thus, in setting the earliest start time for an activity, the calculation takes into account the duration of the first subactivity (DA

(i) for preceding activities involving a start-to-start lead. Algebraically, the term in the earliest start time calculation pertaining to start-to-start precedence constraints ( $ES(i) + SS(i,k)$ ) has two parts with the possibility of activity splitting:

$$(10.13) \quad ES(i) + SS(i,k)$$

$$(10.14) \quad EF(i) - D(i) + SS(i,k) \quad \text{for split preceding activities with } DA(i) < SS(i,k)$$

where  $DA(i)$  is the duration of the first sub-activity of the preceding activity.

The computation of earliest finish time involves similar considerations, except that the finish-to-finish and start-to-finish lag constraints are involved. In this case, a maximization over the following terms is required:

$$(10.15) \quad EF(k) = \text{Maximum}\{ES(k) + D(k), \\ EF(i) + FF(i,k) \text{ for each preceding activity with a FF precedence,} \\ ES(i) + SF(i,k) \text{ for each preceding activity with a SF precedence and which is not split,} \\ EF(i) - D(i) + SF(i,k) \text{ for each preceding activity with a SF precedence and which is split}\}$$

Finally, the necessity to split an activity is also considered. If the earliest possible finish time is greater than the earliest start time plus the activity duration, then the activity must be split.

Another possible extension of the scheduling computations in Table 10-9 would be to include a duration modification capability during the forward and backward passes. This capability would permit alternative work calendars for different activities or for modifications to reflect effects of time of the year on activity durations. For example, the duration of outside work during winter months would be increased. As another example, activities with weekend work permitted might have their weekday durations shortened to reflect weekend work accomplishments.

#### Example 10-4: Impacts of precedence relationships and windows

To illustrate the impacts of different precedence relationships, consider a project consisting of only two activities in addition to the start and finish. The start is numbered activity 0, the first activity is number 1, the second activity is number 2, and the finish is activity 3. Each activity is assumed to have a duration of five days. With a direct finish-to-start precedence relationship without a lag, the critical path calculations reveal:

$$\begin{aligned} ES(0) &= 0 \\ ES(1) &= 0 \\ EF(1) &= ES(1) + D(1) = 0 + 5 = 5 \\ ES(2) &= EF(1) + FS(1,2) = 5 + 0 = 5 \\ EF(2) &= ES(2) + D(2) = 5 + 5 = 10 \\ ES(3) &= EF(2) + FS(2,3) = 10 + 0 = 10 = EF(3) \end{aligned}$$

So the earliest project completion time is ten days.

With a start-to-start precedence constraint with a two day lead, the scheduling calculations are:

$$\begin{aligned} ES(0) &= 0 \\ ES(1) &= 0 \\ EF(1) &= ES(1) + D(1) = 0 + 5 = 5 \\ ES(2) &= ES(1) + SS(1,2) = 0 + 2 = 2 \\ EF(2) &= ES(2) + D(2) = 2 + 5 = 7 \\ ES(3) &= EF(2) + FS(2,3) = 7 + 0 = 7. \end{aligned}$$

In this case, activity 2 can begin two days after the start of activity 1 and proceed in parallel with activity 1. The result is that the project completion date drops from ten days to seven days.

Finally, suppose that a finish-to-finish precedence relationship exists between activity 1 and activity 2 with a two day lag. The scheduling calculations are:

$$\begin{aligned} ES(0) &= 0 = EF(0) \\ ES(1) &= EF(0) + FS(0,1) = 0 + 0 = 0 \\ EF(1) &= ES(1) + D(1) = 0 + 5 = 5 \\ ES(2) &= EF(1) + FF(1,2) - D(2) = 5 + 2 - 5 = 2 \\ EF(2) &= ES(2) + D(2) = 2 + 5 = 7 \\ ES(3) &= EF(2) + FS(2,3) = 7 + 0 = 7 = EF(3) \end{aligned}$$

In this case, the earliest finish for activity 2 is on day seven to allow the necessary two day lag from the completion of activity 1. The minimum project completion time is again seven days.

#### Example 10-5: Scheduling in the presence of leads and windows.

As a second example of the scheduling computations involved in the presence of leads, lags and windows, we shall perform the calculations required for the project shown in Figure 10-15. Start and end activities are included in the project diagram, making a total of eleven activities. The various windows and durations for the activities are summarized in Table 10-10 and the precedence relationships appear in Table 10-11. Only earliest start (WES) and latest finish (WLF) window constraints are included in this example problem. All four types of precedence relationships are included in this project. Note that two activities may have more than one type of precedence relationship at the same time; in this case, activities 2 and 5 have both S-S and F-F precedences. In Figure 10-15, the different precedence relationships are shown by links connecting the activity nodes. The type of precedence relationship is indicated by the beginning or end point of each arrow. For example, start-to-start precedences go from the left portion of the preceding activity to the left portion of the following activity. Application of the activity sorting algorithm (Table 10-9) reveals that the existing activity numbers are appropriate for the critical path algorithm. These activity numbers will be used in the forward and backward pass calculations.

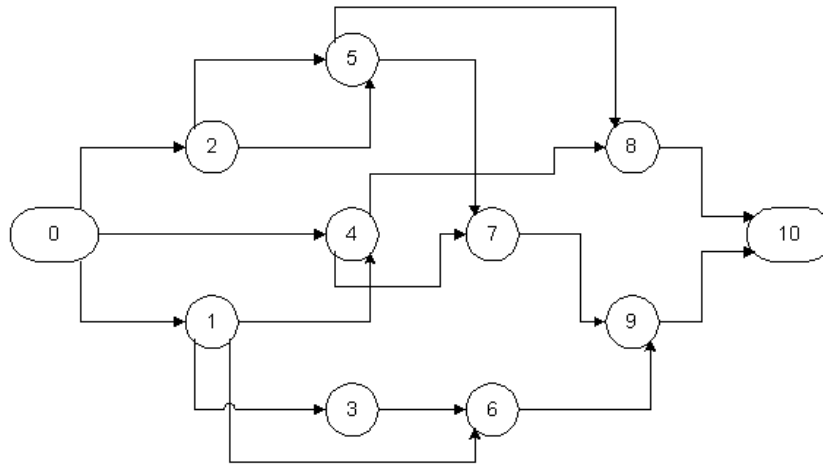

**Figure 10-15** Example Project Network with Lead Precedences

**TABLE 10-10** Predecessors, Successors, Windows and Durations for an Example Project

Activity Number	Predecessors	Successors	Earliest Start Window	Latest Finish Window	Activity Duration
0	---	1, 2, 4	---	---	0
1	0	3, 4, 6	---	---	2
2	0	5	---	---	5
3	1	6	2	---	4
4	0	7, 8	---	---	3
5	2, 2	7, 8	---	16	5
6	1, 3	9	6	16	6
7	4, 5	9	---	---	2
8	4, 5	10	---	---	4
9	6, 7	10	---	16	5
10	8, 9	---	---	---	0

**TABLE 10-11** Precedences in a Eleven Activity Project Example

Predecessor	Successor	Type	Lead
0	1	FS	0
0	2	FS	0
0	4	FS	0
1	3	SS	1
1	4	SF	1
1	6	FS	2
2	5	SS	2
2	5	FF	2
3	6	FS	0
4	7	SS	2
4	8	FS	0
5	7	FS	1

5	8	SS	3
6	9	FF	4
7	9	FS	0
8	10	FS	0
9	10	FS	0

During the forward pass calculations (Table 10-9), the earliest start and earliest finish times are computed for each activity. The relevant calculations are:

$$\begin{aligned}
 ES(0) &= EF(0) = 0 \\
 ES(1) &= \text{Max}\{0; EF(0) + FS(0,1)\} = \text{Max}\{0; 0 + 0\} = 0. \\
 EF(1) &= ES(1) + D(1) = 0 + 2 = 2 \\
 ES(2) &= \text{Max}\{0; EF(0) + FS(0,1)\} = \text{Max}\{0; 0 + 0\} = 0. \\
 EF(2) &= ES(2) + D(2) = 0 + 5 = 5 \\
 ES(3) &= \text{Max}\{0; WES(3); ES(1) + SS(1,3)\} = \text{Max}\{0; 2; 0 + 1\} = 2. \\
 EF(3) &= ES(3) + D(3) = 2 + 4 = 6
 \end{aligned}$$

Note that in the calculation of the earliest start for activity 3, the start was delayed to be consistent with the earliest start time window.

$$\begin{aligned}
 ES(4) &= \text{Max}\{0; ES(0) + FS(0,1); ES(1) + SF(1,4) - D(4)\} = \text{Max}\{0; 0 + 0; 0 + 1 - 3\} = 0. \\
 EF(4) &= ES(4) + D(4) = 0 + 3 = 3 \\
 ES(5) &= \text{Max}\{0; ES(2) + SS(2,5); EF(2) + FF(2,5) - D(5)\} = \text{Max}\{0; 0 + 2; 5 + 2 - 5\} = 2 \\
 EF(5) &= ES(5) + D(5) = 2 + 5 = 7 \\
 ES(6) &= \text{Max}\{0; WES(6); EF(1) + FS(1,6); EF(3) + FS(3,6)\} = \text{Max}\{0; 6; 2 + 2; 6 + 0\} = 6 \\
 EF(6) &= ES(6) + D(6) = 6 + 6 = 12 \\
 ES(7) &= \text{Max}\{0; ES(4) + SS(4,7); EF(5) + FS(5,7)\} = \text{Max}\{0; 0 + 2; 7 + 1\} = 8 \\
 EF(7) &= ES(7) + D(7) = 8 + 2 = 10 \\
 ES(8) &= \text{Max}\{0; EF(4) + FS(4,8); ES(5) + SS(5,8)\} = \text{Max}\{0; 3 + 0; 2 + 3\} = 5 \\
 EF(8) &= ES(8) + D(8) = 5 + 4 = 9 \\
 ES(9) &= \text{Max}\{0; EF(7) + FS(7,9); EF(6) + FF(6,9) - D(9)\} = \text{Max}\{0; 10 + 0; 12 + 4 - 5\} = 11 \\
 EF(9) &= ES(9) + D(9) = 11 + 5 = 16 \\
 ES(10) &= \text{Max}\{0; EF(8) + FS(8,10); EF(9) + FS(9,10)\} = \text{Max}\{0; 9 + 0; 16 + 0\} = 16 \\
 EF(10) &= ES(10) + D(10) = 16
 \end{aligned}$$

As the result of these computations, the earliest project completion time is found to be 16 days.

The backward pass computations result in the latest finish and latest start times for each activity. These calculations are:

$$\begin{aligned}
 LF(10) &= LS(10) = ES(10) = EF(10) = 16 \\
 LF(9) &= \text{Min}\{WLF(9); LF(10); LS(10) - FS(9,10)\} = \text{Min}\{16; 16; 16 - 0\} = 16 \\
 LS(9) &= LF(9) - D(9) = 16 - 5 = 11 \\
 LF(8) &= \text{Min}\{LF(10); LS(10) - FS(8,10)\} = \text{Min}\{16; 16 - 0\} = 16 \\
 LS(8) &= LF(8) - D(8) = 16 - 4 = 12 \\
 LF(7) &= \text{Min}\{LF(10); LS(9) - FS(7,9)\} = \text{Min}\{16; 11 - 0\} = 11 \\
 LS(7) &= LF(7) - D(7) = 11 - 2 = 9 \\
 LF(6) &= \text{Min}\{LF(10); WLF(6); LF(9) - FF(6,9)\} = \text{Min}\{16; 16; 16 - 4\} = 12 \\
 LS(6) &= LF(6) - D(6) = 12 - 6 = 6 \\
 LF(5) &= \text{Min}\{LF(10); WLF(10); LS(7) - FS(5,7); LS(8) - SS(5,8) + D(8)\} = \text{Min}\{16; 16; 9 - 1; 12 - 3 + 4\} = 8 \\
 LS(5) &= LF(5) - D(5) = 8 - 5 = 3 \\
 LF(4) &= \text{Min}\{LF(10); LS(8) - FS(4,8); LS(7) - SS(4,7) + D(7)\} = \text{Min}\{16; 12 - 0; 9 - 2 + 2\} = 9 \\
 LS(4) &= LF(4) - D(4) = 9 - 3 = 6 \\
 LF(3) &= \text{Min}\{LF(10); LS(6) - FS(3,6)\} = \text{Min}\{16; 6 - 0\} = 6 \\
 LS(3) &= LF(3) - D(3) = 6 - 4 = 2 \\
 LF(2) &= \text{Min}\{LF(10); LF(5) - FF(2,5); LS(5) - SS(2,5) + D(5)\} = \text{Min}\{16; 8 - 2; 3 - 2 + 5\} = 6 \\
 LS(2) &= LF(2) - D(2) = 6 - 5 = 1 \\
 LF(1) &= \text{Min}\{LF(10); LS(6) - FS(1,6); LS(3) - SS(1,3) + D(3); LF(4) - SF(1,4) + D(4)\} \\
 LS(1) &= LF(1) - D(1) = 2 - 2 = 0 \\
 LF(0) &= \text{Min}\{LF(10); LS(1) - FS(0,1); LS(2) - FS(0,2); LS(4) - FS(0,4)\} = \text{Min}\{16; 0 - 0; 1 - 0; 6 - 0\} = 0 \\
 LS(0) &= LF(0) - D(0) = 0
 \end{aligned}$$

The earliest and latest start times for each of the activities are summarized in Table 10-12. Activities without float are 0, 1, 6, 9 and 10. These activities also constitute the critical path in the project. Note that activities 6 and 9 are related by a finish-to-finish precedence with a 4 day lag. Decreasing this lag would result in a reduction in the overall project duration.

**TABLE 10-12** Summary of Activity Start and Finish Times for an Example Problem

Activity	Earliest Start	Latest Start	Float
0	0	0	0
1	0	0	0
2	0	1	1
3	0	2	2
4	0	6	6
5	2	3	1
6	6	6	0
7	8	9	1
8	5	12	7
9	11	11	0
10	16	16	0

[Back to top](#)

## 10.8 Resource Oriented Scheduling

Resource constrained scheduling should be applied whenever there are limited resources available for a project and the competition for these resources among the project activities is keen. In effect, delays are liable to occur in such cases as activities must wait until common resources become available. To the extent that resources are limited and demand for the resource is high, this waiting may be considerable. In turn, the congestion associated with these waits represents increased costs, poor productivity and, in the end, project delays. Schedules made without consideration for such bottlenecks can be completely unrealistic.

Resource constrained scheduling is of particular importance in managing multiple projects with fixed resources of staff or equipment. For example, a design office has an identifiable staff which must be assigned to particular projects and design activities. When the workload is heavy, the designers may fall behind on completing their assignments. Government agencies are particularly prone to the problems of fixed staffing levels, although some flexibility in accomplishing tasks is possible through the mechanism of contracting work to outside firms. Construction activities are less susceptible to this type of problem since it is easier and less costly to hire additional personnel for the (relatively) short duration of a construction project. Overtime or double shift work also provide some flexibility.

Resource oriented scheduling also is appropriate in cases in which unique resources are to be used. For example, scheduling excavation operations when one only excavator is available is simply a process of assigning work tasks or job segments on a day by day basis while insuring that appropriate precedence relationships are maintained. Even with more than one resource, this manual assignment process may be quite adequate. However, a planner should be careful to insure that necessary precedences are maintained.

Resource constrained scheduling represents a considerable challenge and source of frustration to researchers in mathematics and operations research. While algorithms for optimal solution of the resource constrained problem exist, they are generally too computationally expensive to be practical for all but small networks (of less than about 100 nodes). [5] The difficulty of the resource constrained project scheduling problem arises from the combinatorial explosion of different resource assignments which can be made and the fact that the decision variables are integer values representing all-or-nothing assignments of a particular resource to a particular activity. In contrast, simple critical path scheduling deals with continuous time variables. Construction projects typically involve many activities, so optimal solution techniques for resource allocation are not practical.

One possible simplification of the resource oriented scheduling problem is to ignore precedence relationships. In some applications, it may be impossible or unnecessary to consider precedence constraints among activities. In these cases, the focus of scheduling is usually on efficient utilization of project resources. To insure minimum cost and delay, a project manager attempts to minimize the amount of time that resources are unused and to minimize the waiting time for scarce resources. This resource oriented scheduling is often formalized as a problem of "job shop" scheduling in which numerous tasks are to be scheduled for completion and a variety of discrete resources need to perform operations to complete the tasks. Reflecting the original orientation towards manufacturing applications, tasks are usually referred to as "jobs" and resources to be scheduled are designated "machines." In the provision of constructed facilities, an analogy would be an architectural/engineering design office in which numerous design related tasks are to be accomplished by individual professionals in different departments. The scheduling problem is to insure efficient use of the individual professionals (i.e. the resources) and to complete specific tasks in a timely manner.

The simplest form of resource oriented scheduling is a reservation system for particular resources. In this case, competing activities or users of a resource pre-arrange use of the resource for a particular time period. Since the resource assignment is known in advance, other users of the resource can schedule their activities more effectively. The result is less waiting or "queuing" for a resource. It is also possible to inaugurate a preference system within the reservation process so that high-priority activities can be accommodated directly.

In the more general case of multiple resources and specialized tasks, practical resource constrained scheduling procedures rely on heuristic procedures to develop good but not necessarily optimal schedules. While this is the occasion for considerable anguish among researchers, the heuristic methods will typically give fairly good results. An example heuristic method is provided in the next section. Manual methods in which a human scheduler revises a critical path schedule in light of resource constraints can also work relatively well. Given that much of the data and the network representation used in forming a project schedule are uncertain, the results of applying heuristic procedures may be quite adequate in practice.

**Example 10-6: A Reservation System** [6]

A recent construction project for a high-rise building complex in New York City was severely limited in the space available for staging materials for hauling up the building. On the four building site, thirty-eight separate cranes and elevators were available, but the number of movements of men, materials and equipment was expected to keep the equipment very busy. With numerous sub-contractors desiring the use of this equipment, the potential for delays and waiting in the limited staging area was considerable. By implementing a crane reservation system, these problems were nearly entirely avoided. The reservation system required contractors to telephone one or more days in advance to reserve time on a particular crane. Time were available on a first-come, first-served basis (i.e. first call, first choice of available slots). Penalties were imposed for making an unused reservation. The reservation system was also computerized to permit rapid modification and updating of information as well as the provision of standard reservation schedules to be distributed to all participants.

### Example 10-7: Heuristic Resource Allocation

Suppose that a project manager has eleven pipe sections for which necessary support structures and materials are available in a particular week. To work on these eleven pipe sections, five crews are available. The allocation problem is to assign the crews to the eleven pipe sections. This allocation would consist of a list of pipe sections allocated to each crew for work plus a recommendation on the appropriate sequence to undertake the work. The project manager might make assignments to minimize completion time, to insure continuous work on the pipeline (so that one section on a pipeline run is not left incomplete), to reduce travel time between pipe sections, to avoid congestion among the different crews, and to balance the workload among the crews. Numerous trial solutions could be rapidly generated, especially with the aid of an electronic spreadsheet. For example, if the nine sections had estimated work durations for each of the five crews as shown in Table 10-13, then the allocations shown in Figure 10-16 would result in a minimum completion time.

**TABLE 10-13** Estimated Required Time for Each Work Task in a Resource Allocation Problem

Section	Work Duration
A	9
B	9
C	8
D	8
E	7
F	7
G	6
H	6
I	6
J	5
K	5

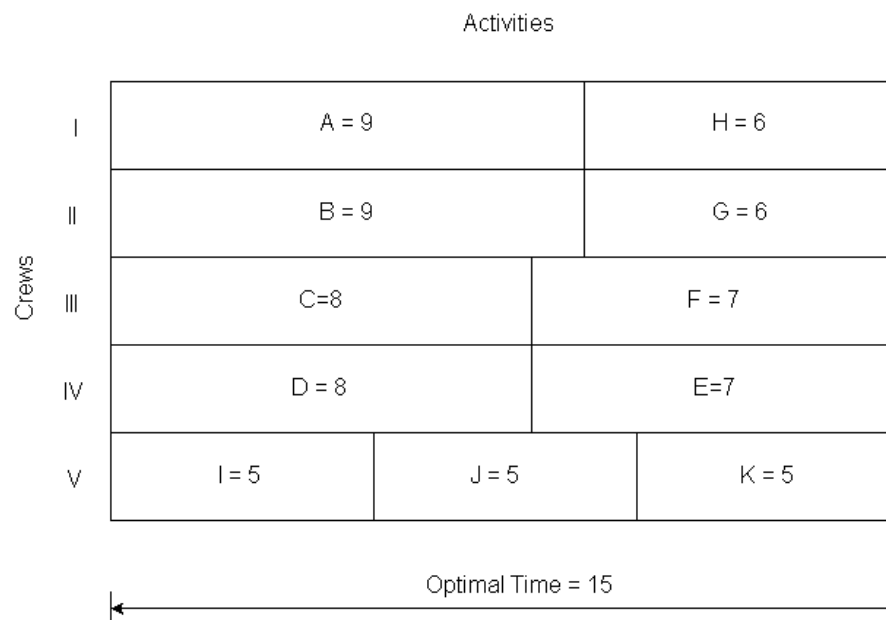

**Figure 10-16** Example Allocation of Crews to Work Tasks

**Example 10-8: Algorithms for Resource Allocation with Bottleneck Resources**

In the previous example, suppose that a mathematical model and solution was desired. For this purpose, we define a binary (i.e. 0 or 1 valued) decision variable for each pipe section and crew,  $x_{ij}$ , where  $x_{ij} = 1$  implies that section  $i$  was assigned to crew  $j$  and  $x_{ij} = 0$  implied that section  $i$  was not assigned to crew  $j$ . The time required to complete each section is  $t_i$ . The overall time to complete the nine sections is denoted  $z$ . In this case, the problem of minimizing overall completion time is:

$$z = \text{maximum} \left( \sum_{i=1}^{11} t_i x_{i1}; \sum_{i=1}^{11} t_i x_{i2}; \sum_{i=1}^{11} t_i x_{i3}; \sum_{i=1}^{11} t_i x_{i4}; \sum_{i=1}^{11} t_i x_{i5}; \right)$$

subject to the constraints:

$$\sum_{j=1}^5 x_{ij} = 1 \quad \text{for each section } i$$

$$x_{ij} \text{ is 0 or 1}$$

where the constraints simply insure that each section is assigned to one and only one crew. A modification permits a more conventional mathematical formulation, resulting in a generalized bottleneck assignment problem:

Minimize  $z$   
subject to the constraints:

$$z \geq \sum_{i=1}^{11} t_i x_{ij} \quad \text{for each crew } j$$

$$\sum_{j=1}^5 x_{ij} = 1 \quad \text{for each section } i$$

$$x_{ij} \text{ is 0 or 1}$$

This problem can be solved as an integer programming problem, although at considerable computational expense. A common extension to this problem would occur with differential productivities for each crew, so that the time to complete an activity,  $t_{ij}$ , would be defined for each crew. Another modification to this problem would substitute a cost factor,  $c_j$ , for the time factor,  $t_j$ , and attempt to minimize overall costs rather than completion time.

[Back to top](#)

**10.9 Scheduling with Resource Constraints and Precedences**

The previous section outlined resource oriented approaches to the scheduling problem. In this section, we shall review some general approaches to integrating both concerns in scheduling.

Two problems arise in developing a resource constrained project schedule. First, it is not necessarily the case that a critical path schedule is feasible. Because one or more resources might be needed by numerous activities, it can easily be the case that the shortest project duration identified by the critical path scheduling calculation is impossible. The difficulty arises because critical path scheduling assumes that no resource availability problems or bottlenecks will arise. Finding a feasible or possible schedule is the first problem in resource constrained scheduling. Of course, there may be a numerous possible schedules which conform with time and resource constraints. As a second problem, it is also desirable to determine schedules which have low costs or, ideally, the lowest cost.

Numerous heuristic methods have been suggested for resource constrained scheduling. Many begin from critical path schedules which are modified in light of the resource constraints. Others begin in the opposite fashion by introducing resource constraints and then imposing precedence constraints on the activities. Still others begin with a ranking or classification of activities into priority groups for special attention in scheduling. [7] One type of heuristic may be better than another for different types of problems. Certainly, projects in which only an occasional resource constraint exists might be best scheduled starting from a critical path schedule. At the other extreme, projects with numerous important resource constraints might be best scheduled by considering critical resources first. A mixed approach would be to proceed simultaneously considering precedence and resource constraints.

A simple modification to critical path scheduling has been shown to be effective for a number of scheduling problems and is simple to implement. For this heuristic procedure, critical path scheduling is applied initially. The result is the familiar set of possible early and late start times for each activity. Scheduling each activity to begin at its earliest possible start time may result in more than one activity requiring a particular resource at the same time. Hence, the initial schedule may not be feasible. The heuristic proceeds by identifying cases in which activities compete for a resource and selecting one activity to proceed. The start time of other activities are then shifted later in time. A simple rule for choosing which activity has priority is to select the activity with the earliest CPM late start time (calculated as  $LS(i,j) = L(j) - D_{ij}$ ) among

those activities which are both feasible (in that all their precedence requirements are satisfied) and competing for the resource. This decision rule is applied from the start of the project until the end for each type of resource in turn.

The order in which resources are considered in this scheduling process may influence the ultimate schedule. A good heuristic to employ in deciding the order in which resources are to be considered is to consider more important resources first. More important resources are those that have high costs or that are likely to represent an important bottleneck for project completion. Once important resources are scheduled, other resource allocations tend to be much easier. The resulting scheduling procedure is described in Table 10-14.

The late start time heuristic described in Table 10-14 is only one of many possible scheduling rules. It has the advantage of giving priority to activities which must start sooner to finish the project on time. However, it is *myopic* in that it doesn't consider trade-offs among resource types nor the changes in the late start time that will be occurring as activities are shifted later in time. More complicated rules can be devised to incorporate broader knowledge of the project schedule. These complicated rules require greater computational effort and may or may not result in scheduling improvements in the end.

**TABLE 10-14** A Resource-Oriented Scheduling Procedure

<i>Step 1:</i>	Rank all resources from the most important to the least important, and number the resources $i = 1, 2, 3, \dots, m$ .
<i>Step 2:</i>	Set the scheduled start time for each activity to the earliest start time.
	For each resource $i = 1, 2, 3, \dots, m$ in turn:
<i>Step 3:</i>	Start at the project beginning, so set $t = 0$ .
<i>Step 4:</i>	Compute the demand for resource $i$ at time $t$ by summing up the requirements for resource $i$ for all activities scheduled to be underway at time $t$ .
	If demand for resource $i$ in time $t$ is greater than the resource availability, then select the activity with the greatest late start time requiring resource $i$ at time $t$ , and shift its scheduled start time to time $t+1$ .
	Repeat Step 4 until the resource constraint at time $t$ for resource $i$ is satisfied.
<i>Step 5:</i>	Repeat step 4 for each project period in turn, setting $t = t+1$ .

**Example 10-9: Resource constrained scheduling with nine activities.**

As an example of resource constrained scheduling, we shall re-examine the nine activity project discussed in Section 10.3. To begin with, suppose that four workers and two pieces of equipment such as backhoes are available for the project. The required resources for each of the nine project activities are summarized in Table 10-15. Graphs of resource requirements over the 30 day project duration are shown in Figure 10-17. Equipment availability in this schedule is not a problem. However, on two occasions, more than the four available workers are scheduled for work. Thus, the existing project schedule is infeasible and should be altered.

**TABLE 10-15** Resources Required and Starting Times for a Nine Activity Project

Activity	Workers Required	Equipment Required	Earliest Start Time	Latest Start Time	Duration
A	2	0	0	0	4
B	2	1	0	9	3
C	2	1	4	4	8
D	2	1	4	15	7
E	2	1	12	13	9
F	2	0	12	12	12
G	2	1	21	22	2
H	2	1	21	25	5
I	4	1	24	24	6



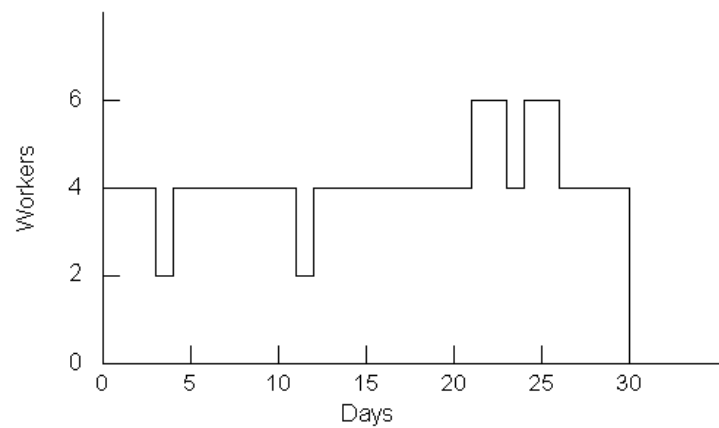

(a) Workers Required

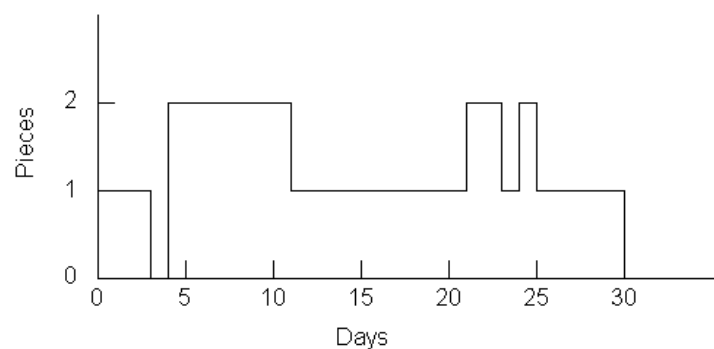

(b) Equipment Required

**Figure 10-17** Resources Required over Time for Nine Activity Project: Schedule I

The first resource problem occurs on day 21 when activity F is underway and activities G and H are scheduled to start. Applying the latest start time heuristic to decide which activity should start, the manager should re-schedule activity H since it has a later value of  $LS(i,j)$ , i.e., day 25 versus day 22 as seen in Table 10-15. Two workers become available on day 23 after the completion of activity G. Since activity H is the only activity which is feasible at that time, it is scheduled to begin. Two workers also become available on day 24 at the completion of activity F. At this point, activity I is available for starting. If possible, it would be scheduled to begin with only two workers until the completion of activity H on day 28. If all 4 workers were definitely required, then activity I would be scheduled to begin on day 28. In this latter case, the project duration would be 34 days, representing a 4 day increase due to the limited number of workers available.

#### Example 10-10: Additional resource constraints.

As another example, suppose that only one piece of equipment was available for the project. As seen in Figure 10-17, the original schedule would have to be significantly modified in this case. Application of the resource constrained scheduling heuristic proceeds as follows as applied to the original project schedule:

1. On day 4, activities D and C are both scheduled to begin. Since activity D has a larger value of late start time, it should be re-scheduled.
2. On day 12, activities D and E are available for starting. Again based on a later value of late start time (15 versus 13), activity D is deferred.
3. On day 21, activity E is completed. At this point, activity D is the only feasible activity and it is scheduled for starting.
4. On day 28, the planner can start either activity G or activity H. Based on the later start time heuristic, activity G is chosen to start.
5. On completion of activity G at day 30, activity H is scheduled to begin.

The resulting profile of resource use is shown in Figure 10-18. Note that activities F and I were not considered in applying the heuristic since these activities did not require the special equipment being considered. In the figure, activity I is scheduled after the completion of activity H due to the requirement of 4 workers for this activity. As a result, the project duration has increased to 41 days. During much of this time, all four workers are not assigned to an activity. At this point, a prudent planner would consider whether or not it would be cost effective to obtain an additional piece of equipment for the project.

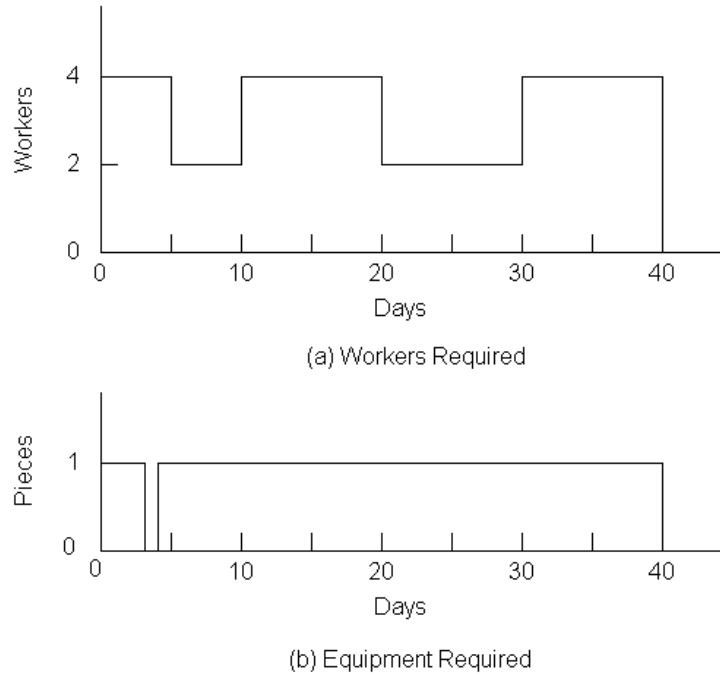

Figure 10-18 Resources Required over Time for Nine Activity Project: Schedule II

[Back to top](#)

### 10.10 References

1. Au, T. *Introduction to Systems Engineering--Deterministic Models*, Addison-Wesley, Reading, MA, 1973, Chapter 8.
2. Baker, K., *An Introduction to Sequencing and Scheduling*, John Wiley, 1974.
3. Jackson, M.J., *Computers in Construction Planning and Control*, Allen & Unwin, 1986.
4. Moder, J., C. Phillips and E. Davis, *Project Management with CPM, PERT and Precedence Diagramming*, Van Nostrand Reinhold Company, Third Edition, 1983.
5. Willis, E. M., *Scheduling Construction Projects*, John Wiley & Sons, 1986.

[Back to top](#)

### 10.11 Problems

1 to 4.

Construct an activity-on-branch network from the precedence relationships of activities in the project given in the table for the problem, Tables 10-16 to 10-19.

TABLE 10-16

Activity	A	B	C	D	E	F	G	H	I	J	K	L	M	N	O
Predecessors	---	A	A	---	B	C,D	C,D	D	H	F	E,J	F	G,I	G,I	L,N
Duration	6	7	1	14	5	8	9	3	5	3	4	12	6	2	7

TABLE 10-17

Activity	A	B	C	D	E	F	G	H	I	J	K	L	M	N
Predecessors	---	A	B	C	D,G	A	F,J	---	H	I	F,J	H	L	K,M
Duration	5	6	3	4	5	8	3	3	2	7	2	7	4	3

TABLE 10-18

Activity	A	B	C	D	E	F	G	H	I	J	K	L	M	N
Predecessors	---	A	B	C	D	E	F	G	H	I	J	K	L	M
Duration	5	6	3	4	5	8	3	3	2	7	2	7	4	3

Activity	A	B	C	D	E	F	G	H	I	J	K	L
Predecessors	---	---	---	A	B	C	B,D	C,E	F	F	E,G,I	H,J
Duration	6	12	16	5	3	10	9	4	5	3	10	6

**TABLE 10-19**

Activity	A	B	C	D	E	F	G	H	I	J	K	L	M
Predecessors	---	---	---	C	C	B,E	A,F	B,E	B,E	B,E	D,J	G,H	I,K,L
Duration	3	6	2	3	8	5	7	10	6	6	8	3	4

5 to 8.

Determine the critical path and all slacks for the projects in Tables 10-16 to 10-19.

9. Suppose that the precedence relationships for Problem 1 in Table 10-16 are all direct finish-to-start relationships with no lags except for the following:
- o B to E: S-S with a lag of 2.
  - o D to H: F-F with a lag of 3.
  - o F to L: S-S with a lag of 2.
  - o G to N: S-S with a lag of 1.
  - o G to M: S-S with a lag of 2.

Formulate an activity-on-node network representation and recompute the critical path with these precedence relationships.

10. Suppose that the precedence relationships for Problem 2 in Table 10-17 are all direct finish-to-start relationships with no lags except for the following:
- o C to D: S-S with a lag of 1
  - o D to E: F-F with a lag of 3
  - o A to F: S-S with a lag of 2
  - o H to I: F-F with a lag of 4
  - o L to M: S-S with a lag of 1

Formulate an activity-on-node network representation and recompute the critical path with these precedence relationships.

11 to 12.

For the projects described in Tables 10-20 and 10-21, respectively, suggest a project schedule that would complete the project in minimum time and result in relatively constant or level requirements for labor over the course of the project.

**TABLE 10-20**

Activity	A	B	C	D	E	F	G	H	I	J	K
Predecessors	---	---	---	A	B	B	C	C	D,E	F,G	H
Duration	3	5	1	1	7	6	4	3	6	4	3
Workers Per Day	9	6	4	10	16	9	5	8	2	3	7

**TABLE 10-21**

Activity	A	B	C	D	E	F	G	H	I	J	K	L	M	N
Predecessors	---	---	---	A	A	A	B	B	C	F,G	H,I,L	F,G	D,J	E,K
Duration	5	1	7	2	6	4	3	2	6	4	5	1	4	5
Workers Per Day	0	3	0	9	5	4	2	14	10	4	1	2	7	3

13. Develop a spreadsheet template that lists activity name, duration, required resources, earliest possible start, latest possible start, and scheduled start in separate columns for a maximum of twenty activities. By means of formulas, also develop the required resources for each day of the project, based on the activities' scheduled start, expected durations, and required resources. Use the spreadsheet graphics facility to plot the required resources over time. Use your template to solve Problems 11 and 12 by altering scheduled start times. (Hint: One way to prepare such a template is to use a column to represent a single day with each cell in the column indicating resources required by a particular activity on the particular day).
14. Develop an example of a project network with three critical paths.

15. For the project defined in Table 10-20, suppose that you are limited to a maximum of 20 workers at any given time. Determine a desirable schedule for the project, using the late start time heuristic described in Section 10.9.
16. For the project defined in Table 10-21, suppose that you are limited to a maximum of 15 workers at any given time. Determine a desirable schedule for the project, using the late start time heuristic described in Section 10.9.
17. The examples and problems presented in this chapter generally make use of activity duration and project durations as measured in working days from the beginning of the project. Outline the procedures by which time measured in working days would be converted into calendar days with single- or double-shift work. Could your procedure be modified to allow some but not all activities to be underway on weekends?

[Back to top](#)

## 10.12 Footnotes

1. See Au, T., *Introduction to Systems Engineering, Deterministic Models*, Addison-Wesley Publishing Company, Reading, MA, 1973, for a detailed description of linear programming as a form of mathematical optimization. [Back](#)
2. See K.C. Crandall, "Project Planning with Precedence Lead/Lag Factors," *Project Management Quarterly*, Vol. 4, No. 3, Sept. 1973, pp. 18-27, or J.J. Moder, C.R. Phillips, and E.W. Davis, *Project Management with CPM, PERT and Precedence Diagramming*, New York: Van Nostrand Reinhold Company, third edition, 1983, chapter 4. [Back](#)
3. See C.T. Hendrickson and B.N. Janson, "A Common Network Formulation of Several Civil Engineering Problems," *Civil Engineering Systems*, Vol. 1, No. 4, 1984, pp. 195-203. [Back](#)
4. See IBM, *Project Management System, Application Description Manual*, (H20-0210), IBM, 1968. [Back](#)
5. A variety of mathematical programming techniques have been proposed for this problem. For a review and comparison, see J.H. Patterson, "A Comparison of Exact Approaches for Solving the Multiple Constrained Resource Project Scheduling Problem," *Management Science*, Vol. 30, No. 7, 1984, pp. 854-867. [Back](#)
6. This example is adapted from H. Smallowitz, "Construction by Computer," *Civil Engineering*, June, 1986, pp. 71-73. [Back](#)
7. For discussions and comparisons of alternative heuristic algorithms, see E.M. Davies, "An experimental investigation of resource allocation in multiactivity projects," *Operational Research Quarterly* Vol. 24, No. 11, July 1976, pp. 1186-1194; J.D. Wiest and F.K. Levy, *A Management Guide to PERT/CPM*, Prentice-Hall, New Jersey, 1977; or S.R. Lawrence, *A Computational Comparison of Heuristic Scheduling Techniques*, Technical Report, Graduate School of Industrial Administration, Carnegie-Mellon University, 1985. [Back](#)

[Previous Chapter](#) | [Table of Contents](#) | [Next Chapter](#)

<a href="#">Go Up to Table of Contents</a>	
<a href="#">Go To Chapter 10 (Fundamental Scheduling Procedures)</a>	<a href="#">Go To Chapter 12 (Cost Control, Monitoring and Accounting)</a>
<i>Advanced Scheduling Techniques</i>	
<a href="#">Use of Advanced Scheduling Techniques</a>	
<a href="#">Scheduling with Uncertain Durations</a>	
<a href="#">Calculations for Monte Carlo Schedule Simulation</a>	
<a href="#">Crashing and Time/Cost Tradeoffs</a>	
<a href="#">Scheduling in Poorly Structured Problems</a>	
<a href="#">Improving the Scheduling Process</a>	
<a href="#">References</a>	
<a href="#">Problems</a>	
<a href="#">Footnotes</a>	

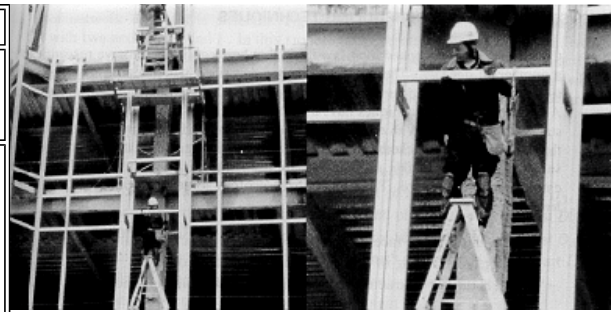

[http://pmbook.ce.cmu.edu/11\\_Advanced\\_Scheduling\\_Techniques.html](http://pmbook.ce.cmu.edu/11_Advanced_Scheduling_Techniques.html)

## 11. Advanced Scheduling Techniques

### 11.1 Use of Advanced Scheduling Techniques

Construction project scheduling is a topic that has received extensive research over a number of decades. The previous chapter described the fundamental scheduling techniques widely used and supported by numerous commercial scheduling systems. A variety of special techniques have also been developed to address specific circumstances or problems. With the availability of more powerful computers and software, the use of advanced scheduling techniques is becoming easier and of greater relevance to practice. In this chapter, we survey some of the techniques that can be employed in this regard. These techniques address some important practical problems, such as:

- scheduling in the face of uncertain estimates on activity durations,
- integrated planning of scheduling and resource allocation,
- scheduling in unstructured or poorly formulated circumstances.

A final section in the chapter describes some possible improvements in the project scheduling process. In Chapter 14, we consider issues of computer based implementation of scheduling procedures, particularly in the context of integrating scheduling with other project management procedures.

[Back to top](#)

### 11.2 Scheduling with Uncertain Durations

Section 10.3 described the application of *critical path scheduling* for the situation in which activity durations are fixed and known. Unfortunately, activity durations are estimates of the actual time required, and there is liable to be a significant amount of uncertainty associated with the actual durations. During the preliminary planning stages for a project, the uncertainty in activity durations is particularly large since the scope and obstacles to the project are still undefined. Activities that are outside of the control of the owner are likely to be more uncertain. For example, the time required to gain regulatory approval for projects may vary tremendously. Other external events such as adverse weather, trench collapses, or labor strikes make duration estimates particularly uncertain.

Two simple approaches to dealing with the uncertainty in activity durations warrant some discussion before introducing more formal scheduling procedures to deal with uncertainty. First, the uncertainty in activity durations may simply be ignored and scheduling done using the expected or most likely time duration for each activity. Since only one duration estimate needs to be made for each activity, this approach reduces the required work in setting up the original schedule. Formal methods of introducing uncertainty into the scheduling process require more work and assumptions. While this simple approach might be defended, it has two drawbacks. First, the use of expected activity durations typically results in overly optimistic schedules for completion; a numerical example of this optimism appears below. Second, the use of single activity durations often produces a rigid, inflexible mindset on the part of schedulers. As field managers appreciate, activity durations vary considerable and can be influenced by good leadership and close attention. As a result, field managers may lose confidence in the realism of a schedule based upon fixed activity durations. Clearly, the use of fixed activity durations in setting up a schedule makes a continual process of monitoring and updating the schedule in light of actual experience imperative. Otherwise, the project schedule is rapidly outdated.

A second simple approach to incorporation uncertainty also deserves mention. Many managers recognize that the use of expected durations may result in overly optimistic schedules, so they include a contingency allowance in their estimate of activity durations. For example, an activity with an expected duration of two days might be scheduled for a period of 2.2 days, including a ten percent contingency. Systematic application of this contingency would result in a ten percent increase in the expected time to complete the

project. While the use of this rule-of-thumb or *heuristic* contingency factor can result in more accurate schedules, it is likely that formal scheduling methods that incorporate uncertainty more formally are useful as a means of obtaining greater accuracy or in understanding the effects of activity delays.

The most common formal approach to incorporate uncertainty in the scheduling process is to apply the critical path scheduling process (as described in Section 10.3) and then analyze the results from a probabilistic perspective. This process is usually referred to as the PERT scheduling or evaluation method. [1] As noted earlier, the duration of the critical path represents the minimum time required to complete the project. Using expected activity durations and critical path scheduling, a critical path of activities can be identified. This critical path is then used to analyze the duration of the project incorporating the uncertainty of the activity durations along the critical path. The expected project duration is equal to the sum of the expected durations of the activities along the critical path. Assuming that activity durations are independent random variables, the variance or variation in the duration of this critical path is calculated as the sum of the variances along the critical path. With the mean and variance of the identified critical path known, the distribution of activity durations can also be computed.

The mean and variance for each activity duration are typically computed from estimates of "optimistic" ( $a_{i,j}$ ), "most likely" ( $m_{i,j}$ ), and "pessimistic" ( $b_{i,j}$ ) activity durations using the formulas:

$$(11.1) \quad \mu(i,j) = \frac{1}{6}(a_{i,j} + 4m_{i,j} + b_{i,j})$$

and

$$(10.2) \quad \sigma^2(i,j) = \frac{1}{36}(b_{i,j} - a_{i,j})^2$$

where  $\mu(i,j)$  and  $\sigma^2(i,j)$  are the mean duration and its variance, respectively, of an activity (i,j). Three activity duration estimates (i.e., optimistic, most likely, and pessimistic durations) are required in the calculation. The use of these optimistic, most likely, and pessimistic estimates stems from the fact that these are thought to be easier for managers to estimate subjectively. The formulas for calculating the mean and variance are derived by assuming that the activity durations follow a probabilistic beta distribution under a restrictive condition. [2] The probability density function of a beta distributions for a random variable x is given by:

$$(11.3) \quad \boxed{\times}$$

$$a \leq x \leq b; \quad \alpha, \beta > -1$$

where k is a constant which can be expressed in terms of  $\alpha$  and  $\beta$ . Several beta distributions for different sets of values of  $\alpha$  and  $\beta$  are shown in Figure 11-1. For a beta distribution in the interval  $a \leq x \leq b$  having a modal value m, the mean is given by:

$$(11.4) \quad \mu = \frac{a + (\alpha + \beta)m + b}{\alpha + \beta + 2}$$

If  $\alpha + \beta = 4$ , then Eq. (11.4) will result in Eq. (11.1). Thus, the use of Eqs. (11.1) and (11.2) impose an additional condition on the beta distribution. In particular, the restriction that  $\sigma = (b - a)/6$  is imposed.

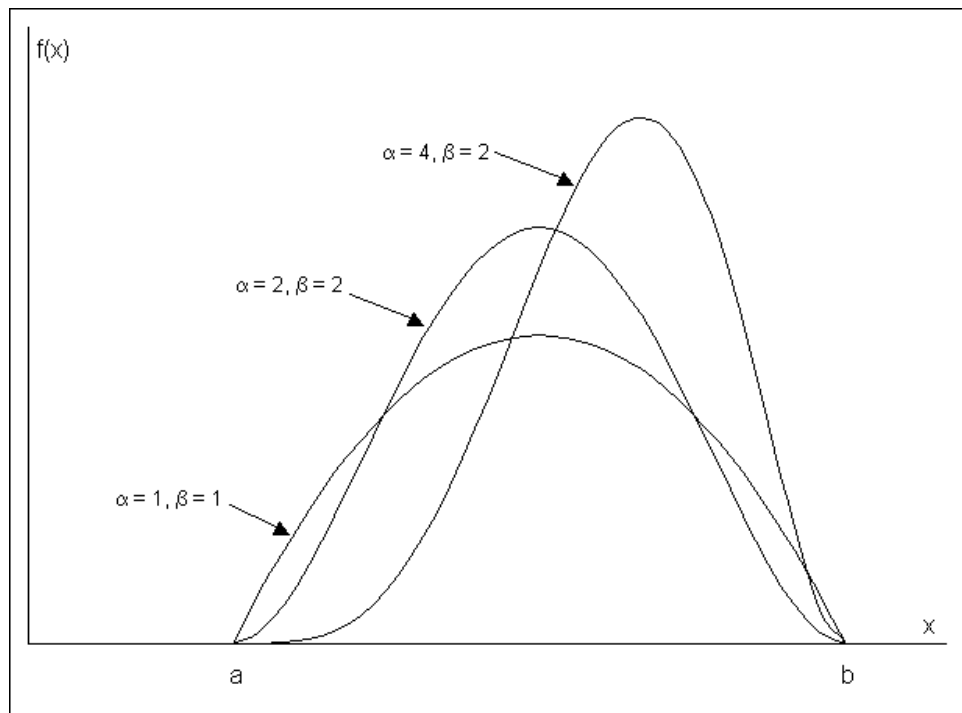

**Figure 11-1** Illustration of Several Beta Distributions

Since absolute limits on the optimistic and pessimistic activity durations are extremely difficult to estimate from historical data, a common practice is to use the ninety-fifth percentile of activity durations for these points. Thus, the optimistic time would be such that there is only a one in twenty (five percent) chance that the actual duration would be less than the estimated optimistic time. Similarly, the pessimistic time is chosen so that there is only a five percent chance of exceeding this duration. Thus, there is a ninety percent chance of having the actual duration of an activity fall between the optimistic and pessimistic duration time estimates. With the use of ninety-fifth percentile values for the optimistic and pessimistic activity duration, the calculation of the expected duration according to Eq. (11.1) is unchanged but the formula for calculating the activity variance becomes:

$$(11.5) \quad \sigma^2(i,j) = \frac{1}{10} \left( b_{i,j}^{95\%} - a_{i,j}^{95\%} \right)^2$$

The difference between Eqs. (11.2) and (11.5) comes only in the value of the divisor, with 36 used for absolute limits and 10 used for ninety-five percentile limits. This difference might be expected since the difference between  $b_{i,j}$  and  $a_{i,j}$  would be *larger* for absolute limits than for the ninety-fifth percentile limits.

While the PERT method has been made widely available, it suffers from three major problems. First, the procedure focuses upon a single critical path, when many paths might become critical due to random fluctuations. For example, suppose that the critical path with longest expected time happened to be completed early. Unfortunately, this does not necessarily mean that the project is completed early since another path or sequence of activities might take longer. Similarly, a longer than expected duration for an activity not on the critical path might result in that activity suddenly becoming critical. As a result of the focus on only a single path, the PERT method typically *underestimates* the actual project duration.

As a second problem with the PERT procedure, it is incorrect to assume that most construction activity durations are independent random variables. In practice, durations are *correlated* with one another. For example, if problems are encountered in the delivery of concrete for a project, this problem is likely to influence the expected duration of numerous activities involving concrete pours on a project. Positive correlations of this type between activity durations imply that the PERT method *underestimates* the variance of the critical path and thereby produces over-optimistic expectations of the probability of meeting a particular project completion deadline.

Finally, the PERT method requires three duration estimates for each activity rather than the single estimate developed for critical path scheduling. Thus, the difficulty and labor of estimating activity characteristics is multiplied threefold.

As an alternative to the PERT procedure, a straightforward method of obtaining information about the *distribution* of project completion times (as well as other schedule information) is through the use of Monte Carlo simulation. This technique calculates sets

of artificial (but realistic) activity duration times and then applies a deterministic scheduling procedure to each set of durations. Numerous calculations are required in this process since simulated activity durations must be calculated and the scheduling procedure applied many times. For realistic project networks, 40 to 1,000 separate sets of activity durations might be used in a single scheduling simulation. The calculations associated with Monte Carlo simulation are described in the following section.

A number of different indicators of the project schedule can be estimated from the results of a Monte Carlo simulation:

- Estimates of the expected time and variance of the project completion.
- An estimate of the distribution of completion times, so that the probability of meeting a particular completion date can be estimated.
- The probability that a particular activity will lie on the critical path. This is of interest since the longest or critical path through the network may change as activity durations change.

The disadvantage of Monte Carlo simulation results from the additional information about activity durations that is required and the computational effort involved in numerous scheduling applications for each set of simulated durations. For each activity, the distribution of possible durations as well as the parameters of this distribution must be specified. For example, durations might be assumed or estimated to be uniformly distributed between a lower and upper value. In addition, *correlations* between activity durations should be specified. For example, if two activities involve assembling forms in different locations and at different times for a project, then the time required for each activity is likely to be closely related. If the forms pose some problems, then assembling them on both occasions might take longer than expected. This is an example of a positive correlation in activity times. In application, such correlations are commonly ignored, leading to errors in results. As a final problem and discouragement, easy to use software systems for Monte Carlo simulation of project schedules are not generally available. This is particularly the case when correlations between activity durations are desired.

Another approach to the simulation of different activity durations is to develop specific scenarios of events and determine the effect on the overall project schedule. This is a type of "what-if" problem solving in which a manager simulates events that might occur and sees the result. For example, the effects of different weather patterns on activity durations could be estimated and the resulting schedules for the different weather patterns compared. One method of obtaining information about the range of possible schedules is to apply the scheduling procedure using all optimistic, all most likely, and then all pessimistic activity durations. The result is three project schedules representing a range of possible outcomes. This process of "what-if" analysis is similar to that undertaken during the process of construction planning or during analysis of project *crashing*.

#### Example 11-1: Scheduling activities with uncertain time durations.

Suppose that the nine activity example project shown in Table 10-2 and Figure 10-4 of Chapter 10 was thought to have very uncertain activity time durations. As a result, project scheduling considering this uncertainty is desired. All three methods (PERT, Monte Carlo simulation, and "What-if" simulation) will be applied.

Table 11-1 shows the estimated optimistic, most likely and pessimistic durations for the nine activities. From these estimates, the mean, variance and standard deviation are calculated. In this calculation, ninety-fifth percentile estimates of optimistic and pessimistic duration times are assumed, so that Equation (11.5) is applied. The critical path for this project ignoring uncertainty in activity durations consists of activities A, C, F and I as found in Table 10-3 (Section 10.3). Applying the PERT analysis procedure suggests that the duration of the project would be approximately normally distributed. The sum of the means for the critical activities is  $4.0 + 8.0 + 12.0 + 6.0 = 30.0$  days, and the sum of the variances is  $0.4 + 1.6 + 1.6 + 1.6 = 5.2$  leading to a standard deviation of 2.3 days.

With a normally distributed project duration, the probability of meeting a project deadline is equal to the probability that the standard normal distribution is less than or equal to  $(PD - \mu_D) / \sigma_D$  where PD is the project deadline,  $\mu_D$  is the expected duration and  $\sigma_D$  is the standard deviation of project duration. For example, the probability of project completion within 35 days is:

$$\begin{aligned} Pr \left\{ D \leq PD \right\} &= Pr \left\{ z \leq \frac{PD - \mu_D}{\sigma_D} \right\} \\ &= Pr \left\{ z \leq \frac{35 - 30.0}{2.3} \right\} = Pr \left\{ z \leq 2.17 \right\} \end{aligned}$$

where  $z$  is the standard normal distribution tabulated value of the cumulative standard distribution appears in Table B.1 of Appendix B.

Monte Carlo simulation results provide slightly different estimates of the project duration characteristics. Assuming that



activity durations are independent and approximately normally distributed random variables with the mean and variances shown in Table 11-1, a simulation can be performed by obtaining simulated duration realization for each of the nine activities and applying critical path scheduling to the resulting network. Applying this procedure 500 times, the average project duration is found to be 30.9 days with a standard deviation of 2.5 days. The PERT result is less than this estimate by 0.9 days or three percent. Also, the critical path considered in the PERT procedure (consisting of activities A, C, F and I) is found to be the critical path in the simulated networks less than half the time.

**TABLE 11-1** Activity Duration Estimates for a Nine Activity Project

Activity	Optimistic Duration	Most Likely Duration	Pessimistic Duration	Mean	Variance
A	3	4	5	4.0	0.4
B	2	3	5	3.2	0.9
C	6	8	10	8.0	1.6
D	5	7	8	6.8	0.9
E	6	9	14	9.3	6.4
F	10	12	14	12.0	1.6
G	2	2	4	2.3	0.4
H	4	5	8	5.3	1.6
I	4	6	8	6.0	1.6

If there are correlations among the activity durations, then significantly different results can be obtained. For example, suppose that activities C, E, G and H are all positively correlated random variables with a correlation of 0.5 for each pair of variables. Applying Monte Carlo simulation using 500 activity network simulations results in an average project duration of 36.5 days and a standard deviation of 4.9 days. This estimated average duration is 6.5 days or 20 percent longer than the PERT estimate or the estimate obtained ignoring uncertainty in durations. If correlations like this exist, these methods can seriously underestimate the actual project duration.

Finally, the project durations obtained by assuming all optimistic and all pessimistic activity durations are 23 and 41 days respectively. Other "what-if" simulations might be conducted for cases in which peculiar soil characteristics might make excavation difficult; these soil peculiarities might be responsible for the correlations of excavation activity durations described above.

Results from the different methods are summarized in Table 11-2. Note that positive correlations among some activity durations results in relatively large increases in the expected project duration and variability.

**TABLE 11-2** Project Duration Results from Various Techniques and Assumptions for an Example

Procedure and Assumptions	Project Duration (days)	Standard Deviation of Project Duration (days)
Critical Path Method	30.0	NA
PERT Method	30.0	2.3
Monte Carlo Simulation		
No Duration Correlations	30.9	2.5
Positive Duration Correlations	36.5	4.9
"What-if" Simulations		
Optimistic	23.0	NA
Most Likely	30.0	NA
Pessimistic	41.0	NA

[Back to top](#)

## 11.3 Calculations for Monte Carlo Schedule Simulation

In this section, we outline the procedures required to perform Monte Carlo simulation for the purpose of schedule analysis. These procedures presume that the various steps involved in forming a network plan and estimating the characteristics of the probability distributions for the various activities have been completed. Given a plan and the activity duration distributions, the heart of the Monte Carlo simulation procedure is the derivation of a *realization* or synthetic outcome of the relevant activity durations. Once these realizations are generated, standard scheduling techniques can be applied. We shall present the formulas associated with the generation of normally distributed activity durations, and then comment on the requirements for other distributions in an example.

To generate normally distributed realizations of activity durations, we can use a two step procedure. First, we generate uniformly

distributed random variables,  $u_i$  in the interval from zero to one. Numerous techniques can be used for this purpose. For example, a general formula for random number generation can be of the form:

$$(11.6) \quad u_i = \text{fractional part of } \left[ (\pi + u_{i-1})^5 \right]$$

where  $\pi = 3.14159265$  and  $u_{i-1}$  was the previously generated random number or a pre-selected beginning or seed number. For example, a seed of  $u_0 = 0.215$  in Eq. (11.6) results in  $u_1 = 0.0820$ , and by applying this value of  $u_1$ , the result is  $u_2 = 0.1029$ . This formula is a special case of the mixed congruential method of random number generation. While Equation (11.6) will result in a series of numbers that have the appearance and the necessary statistical properties of true random numbers, we should note that these are actually "pseudo" random numbers since the sequence of numbers will repeat given a long enough time.

With a method of generating uniformly distributed random numbers, we can generate normally distributed random numbers using two uniformly distributed realizations with the equations: [3]

$$(11.7) \quad x_k = \mu_x + s \sin t$$

with

$$s = \sigma_x \sqrt{-2 \ln u_1}$$

$$t = 2\pi u_2$$

where  $x_k$  is the normal realization,  $\mu_x$  is the mean of  $x$ ,  $\sigma_x$  is the standard deviation of  $x$ , and  $u_1$  and  $u_2$  are the two uniformly distributed random variable realizations. For the case in which the mean of an activity is 2.5 days and the standard deviation of the duration is 1.5 days, a corresponding realization of the duration is  $s = 2.2365$ ,  $t = 0.6465$  and  $x_k = 2.525$  days, using the two uniform random numbers generated from a seed of 0.215 above.

Correlated random number realizations may be generated making use of conditional distributions. For example, suppose that the duration of an activity  $d$  is normally distributed and correlated with a second normally distributed random variable  $x$  which may be another activity duration or a separate factor such as a weather effect. Given a realization  $x_k$  of  $x$ , the conditional distribution of  $d$  is still normal, but it is a function of the value  $x_k$ . In particular, the conditional mean ( $\mu'_d | x = x_k$ ) and standard deviation ( $\sigma'_d | x = x_k$ ) of a normally distributed variable given a realization of the second variable is:

$$(11.8) \quad \left\{ \begin{aligned} \mu'_d | x = x_k &= \rho_{dx} (\sigma_d / \sigma_x) (x_k - \mu_x) + \mu_d \\ \sigma'_d | x = x_k &= \sigma_d \sqrt{1 - \rho_{dx}^2} \end{aligned} \right.$$

where  $\rho_{dx}$  is the correlation coefficient between  $d$  and  $x$ . Once  $x_k$  is known, the conditional mean and standard deviation can be calculated from Eq. (11.8) and then a realization of  $d$  obtained by applying Equation (11.7).

Correlation coefficients indicate the extent to which two random variables will tend to vary together. Positive correlation coefficients indicate one random variable will tend to exceed its mean when the other random variable does the same. From a set of  $n$  historical observations of two random variables,  $x$  and  $y$ , the correlation coefficient can be estimated as:

$$(11.9) \quad \rho_{xy} = \frac{n \sum_{i=1}^n x_i y_i - \sum_{i=1}^n x_i \sum_{i=1}^n y_i}{\left[ n \sum_{i=1}^n x_i^2 - \left( \sum_{i=1}^n x_i \right)^2 \right]^{1/2} \left[ n \sum_{i=1}^n y_i^2 - \left( \sum_{i=1}^n y_i \right)^2 \right]^{1/2}}$$

The value of  $\rho_{xy}$  can range from one to minus one, with values near one indicating a positive, near linear relationship between the two random variables.

It is also possible to develop formulas for the conditional distribution of a random variable correlated with numerous other variables; this is termed a multi-variate distribution. [4] Random number generations from other types of distributions are also possible. [5] Once a set of random variable distributions is obtained, then the process of applying a scheduling algorithm is required as described in previous sections.

### Example 11-2: A Three-Activity Project Example

Suppose that we wish to apply a Monte Carlo simulation procedure to a simple project involving three activities in series. As a result, the critical path for the project includes all three activities. We assume that the durations of the activities are normally distributed with the following parameters:

Activity	Mean (Days)	Standard Deviation (Days)
A	2.5	1.5
B	5.6	2.4
C	2.4	2.0

To simulate the schedule effects, we generate the duration realizations shown in Table 11-3 and calculate the project duration for each set of three activity duration realizations.

For the twelve sets of realizations shown in the table, the mean and standard deviation of the project duration can be estimated to be 10.49 days and 4.06 days respectively. In this simple case, we can also obtain an analytic solution for this duration, since it is only the sum of three independent normally distributed variables. The actual project duration has a mean of 10.5 days, and a standard deviation of  $\sqrt{(1.5)^2 + (2.4)^2 + (2.0)^2} = 3.5$  days. With only a limited number of simulations, the mean obtained from simulations is close to the actual mean, while the estimated standard deviation from the simulation differs significantly from the actual value. This latter difference can be attributed to the nature of the set of realizations used in the simulations; using a larger number of simulated durations would result in a more accurate estimate of the standard deviation.

**TABLE 11-3** Duration Realizations for a Monte Carlo Schedule Simulation

Simulation Number	Activity A	Activity B	Activity C	Project Duration
1	1.53	6.94	1.04	9.51
2	2.67	4.83	2.17	9.66
3	3.36	6.86	5.56	15.78
4	0.39	7.65	2.17	10.22
5	2.50	5.82	1.74	10.06
6	2.77	8.71	4.03	15.51
7	3.83	2.05	1.10	6.96
8	3.73	10.57	3.24	17.53
9	1.06	3.68	2.47	7.22
10	1.17	0.86	1.37	3.40
11	1.68	9.47	0.13	11.27
12	0.37	6.66	1.70	8.72
Estimated Mean Project Duration = 10.49				
Estimated Standard Deviation of Project Duration = 4.06				

Note: All durations in days.

### Example 11-3: Generation of Realizations from Triangular Distributions

To simplify calculations for Monte Carlo simulation of schedules, the use of a triangular distribution is advantageous compared to the normal or the beta distributions. Triangular distributions also have the advantage relative to the normal distribution that negative durations cannot be estimated. As illustrated in Figure 11-2, the triangular distribution can be skewed to the right or left and has finite limits like the beta distribution. If  $a$  is the lower limit,  $b$  the upper limit and  $m$  the most likely value, then the mean and standard deviation of a triangular distribution are:

$$(11.10)$$

$$(11.11) \quad \begin{aligned} \mu &= \frac{a+b+m}{3} \\ \sigma &= \sqrt{\frac{a^2+b^2+m^2-ab-am-mb}{18}} \end{aligned}$$

The cumulative probability function for the triangular distribution is:

$$(11.12) \quad F(x) = \begin{cases} \frac{(x-a)^2}{(b-a)(m-a)} & \text{for } a \leq x \leq m \\ 1 - \frac{(b-x)^2}{(b-a)(b-m)} & \text{for } m \leq x \leq b \end{cases}$$

where  $F(x)$  is the probability that the random variable is less than or equal to the value of  $x$ .

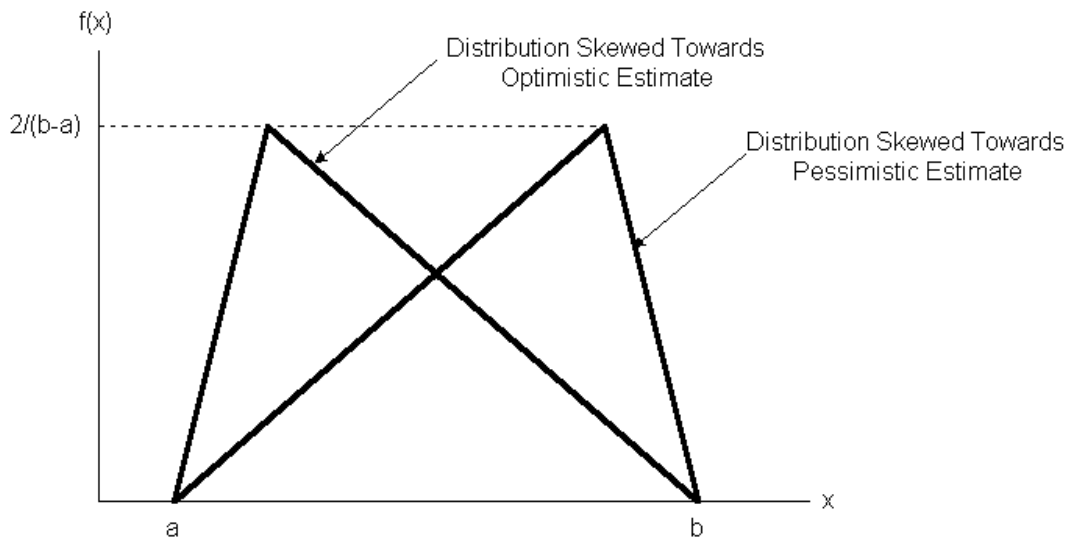

**Figure 11-2** Illustration of Two Triangular Activity Duration Distributions

Generating a random variable from this distribution can be accomplished with a single uniform random variable realization using the inversion method. In this method, a realization of the cumulative probability function,  $F(x)$  is generated and the corresponding value of  $x$  is calculated. Since the cumulative probability function varies from zero to one, the density function realization can be obtained from the uniform value random number generator, Equation (11.6). The calculation of the corresponding value of  $x$  is obtained from inverting Equation (11.12):

$$(11.13) \quad x_k = \begin{cases} a + \sqrt{u_k(b-a)(m-a)} & \text{if } u_k \leq \frac{m-a}{b-a} \\ b - \sqrt{(1-u_k)(b-a)(b-m)} & \text{if } u_k > \frac{m-a}{b-a} \end{cases}$$

For example, if  $a = 3.2$ ,  $m = 4.5$  and  $b = 6.0$ , then  $\mu_x = 4.8$  and  $\sigma_x = 2.7$ . With a uniform realization of  $u = 0.215$ , then for  $(m-a)/(b-a) \geq 0.215$ ,  $x$  will lie between  $a$  and  $m$  and is found to have a value of 4.1 from Equation (11.13).

[Back to top](#)

## 11.4 Crashing and Time/Cost Tradeoffs

The previous sections discussed the duration of activities as either fixed or random numbers with known characteristics. However, activity durations can often vary depending upon the type and amount of resources that are applied. Assigning more workers to a particular activity will normally result in a shorter duration. [6] Greater speed may result in higher costs and lower quality, however. In this section, we shall consider the impacts of time, cost and quality tradeoffs in activity durations. In this process, we shall discuss the procedure of *project crashing* as described below.

A simple representation of the possible relationship between the duration of an activity and its direct costs appears in Figure 11-3. Considering only this activity in isolation and without reference to the project completion deadline, a manager would undoubtedly choose a duration which implies minimum direct cost, represented by  $D_{ij}$  and  $C_{ij}$  in the figure. Unfortunately, if each activity was scheduled for the duration that resulted in the minimum direct cost in this way, the time to complete the entire project might be too long and substantial penalties associated with the late project start-up might be incurred. This is a small example of *sub-optimization*, in which a small component of a project is optimized or improved to the detriment of the entire project performance. Avoiding this problem of sub-optimization is a fundamental concern of project managers.

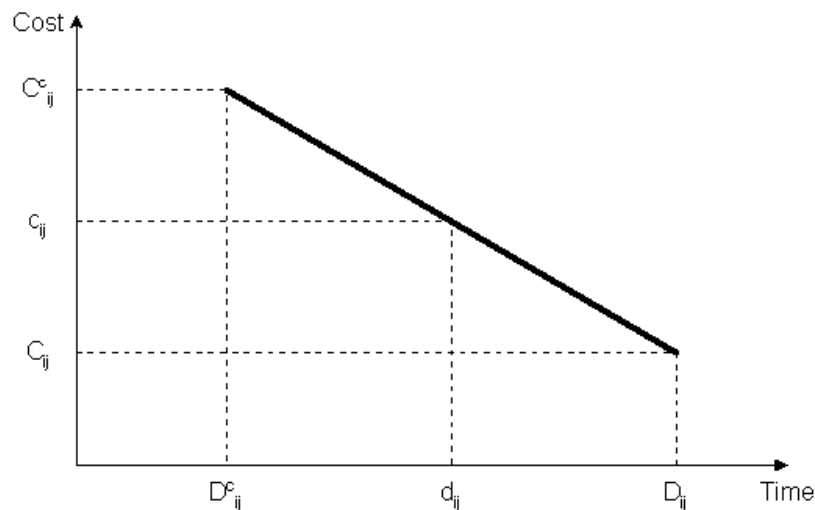

**Figure 11-3** Illustration of a Linear Time/Cost Tradeoff for an Activity

At the other extreme, a manager might choose to complete the activity in the minimum possible time,  $D_{ij}^c$ , but at a higher cost  $C_{ij}^c$ . This minimum completion time is commonly called the activity *crash* time. The linear relationship shown in the figure between these two points implies that any intermediate duration could also be chosen. It is possible that some intermediate point may represent the ideal or optimal trade-off between time and cost for this activity.

What is the reason for an increase in direct cost as the activity duration is reduced? A simple case arises in the use of overtime work. By scheduling weekend or evening work, the completion time for an activity as measured in calendar days will be reduced. However, premium wages must be paid for such overtime work, so the cost will increase. Also, overtime work is more prone to accidents and quality problems that must be corrected, so indirect costs may also increase. More generally, we might not expect a *linear* relationship between duration and direct cost, but some convex function such as the nonlinear curve or the step function shown in Figure 11-4. A linear function may be a good approximation to the actual curve, however, and results in considerable analytical simplicity. [7]

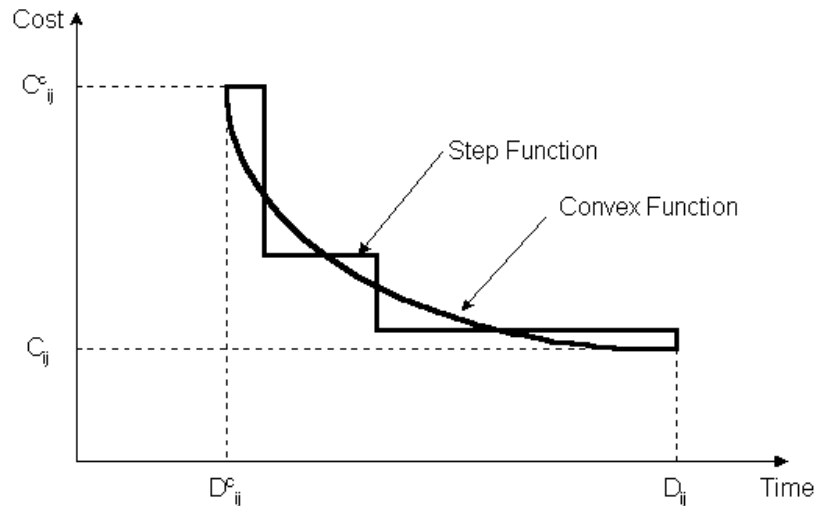

**Figure 11-4** Illustration of Non-linear Time/Cost Tradeoffs for an Activity

With a linear relationship between cost and duration, the critical path time/cost tradeoff problem can be defined as a linear programming optimization problem. In particular, let  $R_{ij}$  represent the rate of change of cost as duration is decreased, illustrated by the absolute value of the slope of the line in Figure 11-3. Then, the direct cost of completing an activity is:

$$(11.14) \quad c_{ij} = C_{ij} + R_{ij}(D_{ij} - d_{ij})$$

where the lower case  $c_{ij}$  and  $d_{ij}$  represent the scheduled duration and resulting cost of the activity  $ij$ . The actual duration of an activity must fall between the minimum cost time ( $D_{ij}^c$ ) and the crash time ( $D_{ij}$ ). Also, precedence constraints must be imposed as described earlier for each activity. Finally, the required completion time for the project or, alternatively, the costs associated with different completion times must be defined. Thus, the entire scheduling problem is to minimize total cost (equal to the sum of the  $c_{ij}$  values for all activities) subject to constraints arising from (1) the desired project duration,  $PD$ , (2) the minimum and maximum activity duration possibilities, and (3) constraints associated with the precedence or completion times of activities. Algebraically, this is:

$$(11.15) \quad \text{Minimize } z = \sum_{\text{all}(i,j)} c_{ij} = \sum_{\text{all}(i,j)} [C_{ij} + R_{ij}(D_{ij} - d_{ij})]$$

subject to the constraints:

$$\begin{aligned} x(n) &\leq PD \\ x(i) + d_{ij} &\leq x(j) \quad \text{for all activities } (ij) \\ D_{ij}^c &\leq d_{ij} \leq D_{ij} \quad \text{for all activities}(ij) \end{aligned}$$

where the notation is defined above and the decision variables are the activity durations  $d_{ij}$  and event times  $x(k)$ . The appropriate schedules for different project durations can be found by repeatedly solving this problem for different project durations  $PD$ . The entire problem can be solved by linear programming or more efficient algorithms which take advantage of the special network form of the problem constraints.

One solution to the time-cost tradeoff problem is of particular interest and deserves mention here. The minimum time to complete a project is called the *project-crash time*. This minimum completion time can be found by applying critical path scheduling with all

activity durations set to their minimum values ( $D_{ij}^c$ ). This minimum completion time for the project can then be used in the time-cost scheduling problem described above to determine the minimum *project-crash cost*. Note that the project crash cost is not found by setting each activity to its crash duration and summing up the resulting costs; this solution is called the *all-crash cost*. Since there are some activities not on the critical path that can be assigned longer duration without delaying the project, it is advantageous to change the all-crash schedule and thereby reduce costs.

Heuristic approaches are also possible to the time/cost tradeoff problem. In particular, a simple approach is to first apply critical path scheduling with all activity durations assumed to be at minimum cost ( $D_{ij}$ ). Next, the planner can examine activities on the critical path and reduce the scheduled duration of activities which have the lowest resulting increase in costs. In essence, the planner develops a list of activities on the critical path ranked in accordance with the unit change in cost for a reduction in the activity duration. The heuristic solution proceeds by shortening activities in the order of their lowest impact on costs. As the duration of activities on the shortest path are shortened, the project duration is also reduced. Eventually, another path becomes critical, and a new list of activities on the critical path must be prepared. By manual or automatic adjustments of this kind, good but not necessarily optimal schedules can be identified. Optimal or best schedules can only be assured by examining changes in combinations of activities as well as changes to single activities. However, by alternating between adjustments in particular activity durations (and their costs) and a critical path scheduling procedure, a planner can fairly rapidly devise a shorter schedule to meet a particular project deadline or, in the worst case, find that the deadline is impossible of accomplishment.

This type of heuristic approach to time-cost tradeoffs is essential when the time-cost tradeoffs for each activity are not known in advance or in the case of resource constraints on the project. In these cases, heuristic explorations may be useful to determine if greater effort should be spent on estimating time-cost tradeoffs or if additional resources should be retained for the project. In many cases, the basic time/cost tradeoff might not be a smooth curve as shown in Figure 11-4, but only a series of particular resource and schedule combinations which produce particular durations. For example, a planner might have the option of assigning either one or two crews to a particular activity; in this case, there are only two possible durations of interest.

#### Example 11-4: Time/Cost Trade-offs

The construction of a permanent transitway on an expressway median illustrates the possibilities for time/cost trade-offs in construction work. [8] One section of 10 miles of transitway was built in 1985 and 1986 to replace an existing contra-flow lane system (in which one lane in the expressway was reversed each day to provide additional capacity in the peak flow direction). Three engineers' estimates for work time were prepared:

- 975 calendar day, based on 750 working days at 5 days/week and 8 hours/day of work plus 30 days for bad weather, weekends and holidays.
- 702 calendar days, based on 540 working days at 6 days/week and 10 hours/day of work.
- 360 calendar days, based on 7 days/week and 24 hours/day of work.

The savings from early completion due to operating savings in the contra-flow lane and contract administration costs were estimated to be \$5,000 per day.

In accepting bids for this construction work, the owner required both a dollar amount and a completion date. The bidder's completion date was required to fall between 360 and 540 days. In evaluating contract bids, a \$5,000 credit was allowed for each day less than 540 days that a bidder specified for completion. In the end, the successful bidder completed the project in 270 days, receiving a bonus of  $5,000 \times (540 - 270) = \$450,000$  in the \$8,200,000 contract. However, the contractor experienced fifteen to thirty percent higher costs to maintain the continuous work schedule.

#### Example 11-5: Time cost trade-offs and project crashing

As an example of time/cost trade-offs and project crashing, suppose that we needed to reduce the project completion time for a seven activity product delivery project first analyzed in Section 10.3 as shown in Table 10-4 and Figure 10-7. Table 11-4 gives information pertaining to possible reductions in time which might be accomplished for the various activities. Using the minimum cost durations (as shown in column 2 of Table 11-4), the critical path includes activities C,E,F,G plus a dummy activity X. The project duration is 32 days in this case, and the project cost is \$70,000.

**TABLE 11-4** Activity Durations and Costs for a Seven Activity Project

Activity	Minimum Cost	Normal Duration	Crash Cost	Crash Duration	Change in Cost per Day
A	8	6	14	4	3
B	4	1	4	1	---
C	8	8	24	4	4
D	10	5	24	3	7
E	10	9	18	5	2
F	20	12	36	6	2.7

G	10	3	18	2	8
---	----	---	----	---	---

Examining the unit change in cost,  $R_{ij}$ , shown in column 6 of Table 11-4, the lowest rate of change occurs for activity E.

Accordingly, a good heuristic strategy might be to begin by crashing this activity. The result is that the duration of activity E goes from 9 days to 5 days and the total project cost increases by \$8,000. After making this change, the project duration drops to 28 days and two critical paths exist: (1) activities C,X,E,F and G, and (2) activities C, D, F, and G.

Examining the unit changes in cost again, activity F has the lowest value of  $R_{ij}$ . Crashing this activity results in an additional time savings of 6 days in the project duration, an increase in project cost of \$16,000, but no change in the critical paths. The activity on the critical path with the next lowest unit change in cost is activity C. Crashing this activity to its minimum completion time would reduce its duration by 4 days at a cost increase of \$16,000. However, this reduction does not result in a reduction in the duration of the project by 4 days. After activity C is reduced to 7 days, then the alternate sequence of activities A and B lie on the critical path and further reductions in the duration of activity C alone do not result in project time savings. Accordingly, our heuristic corrections might be limited to reducing activity C by only 1 day, thereby increasing costs by \$4,000 and reducing the project duration by 1 day.

At this point, our choices for reducing the project duration are fairly limited. We can either reduce the duration of activity G or, alternatively, reduce activity C and either activity A or activity B by an identical amount. Inspection of Table 11-4 and Figure 10-4 suggest that reducing activity A and activity C is the best alternative. Accordingly, we can shorten activity A to its crash duration (from 6 days to 4 days) and shorten the duration of activity C (from 7 days to 5 days) at an additional cost of \$6,000 + \$8,000 = \$14,000. The result is a reduction in the project duration of 2 days.

Our last option for reducing the project duration is to crash activity G from 3 days to 2 days at an increase in cost of \$8,000. No further reductions are possible in this time since each activity along a critical path (comprised of activities A, B, E, F and G) are at minimum durations. At this point, the project duration is 18 days and the project cost is \$120,000., representing a fifty percent reduction in project duration and a seventy percent increase in cost. Note that not all the activities have been crashed. Activity C has been reduced in duration to 5 days (rather than its 4 day crash duration), while activity D has not been changed at all. If all activities had been crashed, the total project cost would have been \$138,000, representing a useless expenditure of \$18,000. The change in project cost with different project durations is shown graphically in Figure 11-5.

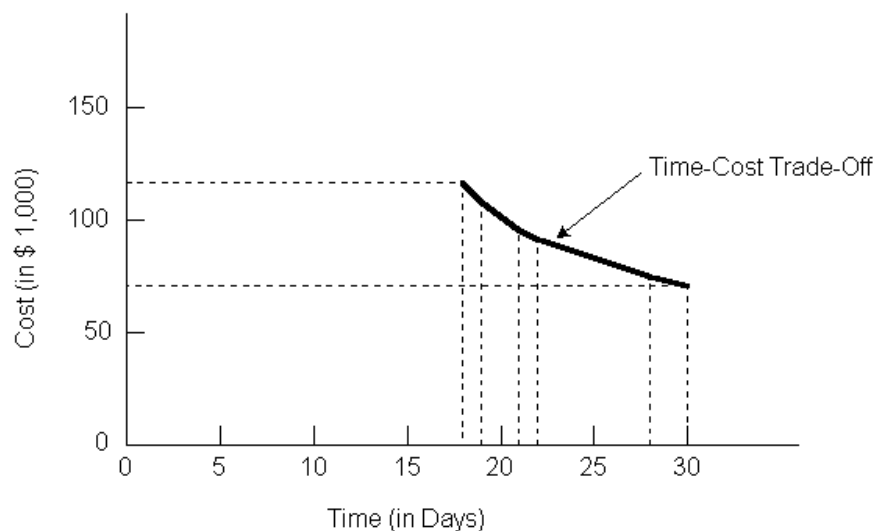

**Figure 11-5** Project Cost Versus Time for a Seven Activity Project

### Example 11-8: Mathematical Formulation of Time-Cost Trade-offs

The same results obtained in the previous example could be obtained using a formal optimization program and the data appearing in Tables 10-4 and 11-4. In this case, the heuristic approach used above has obtained the optimal solution at each stage. Using Eq. (11.15), the linear programming problem formulation would be:



$$\begin{aligned} \text{Minimize } z &= \sum_{k=1}^7 c_k \\ &= [8+3(6-d_A)] + [4] + [8+4(8-d_C)] + [10+7(5-d_D)] \\ &\quad + [10+2(9-d_E)] + [20+2.7(9-d_F)] + [10+2(3-d_G)] \end{aligned}$$

subject to the constraints

$$\begin{aligned} x(6) &= PD \quad x(0) + d_A \leq x(2) \\ x(0) + d_C &\leq x(1) \\ x(1) &\leq x(3) \\ x(2) + d_B &\leq x(4) \\ x(1) + d_D &\leq x(4) \\ x(2) + d_E &\leq x(4) \\ x(4) + d_F &\leq x(5) \\ x(5) + d_G &\leq x(6) \\ x(0) &= 0 \\ 4 &\leq d_A \leq 6 \\ 1 &\leq d_B \leq 1 \\ 4 &\leq d_C \leq 8 \\ 3 &\leq d_D \leq 5 \\ 5 &\leq d_E \leq 9 \\ 6 &\leq d_F \leq 12 \\ 2 &\leq d_G \leq 3 \end{aligned}$$

which can be solved for different values of project duration PD using a linear programming algorithm or a network flow algorithm. Note that even with only seven activities, the resulting linear programming problem is fairly large.

[Back to top](#)

## 11.5 Scheduling in Poorly Structured Problems

The previous discussion of activity scheduling suggested that the general structure of the construction plan was known in advance. With previously defined activities, relationships among activities, and required resources, the scheduling problem could be represented as a mathematical optimization problem. Even in the case in which durations are uncertain, we assumed that the underlying probability distribution of durations is known and applied analytical techniques to investigate schedules.

While these various scheduling techniques have been exceedingly useful, they do not cover the range of scheduling problems encountered in practice. In particular, there are many cases in which costs and durations depend upon other activities due to congestion on the site. In contrast, the scheduling techniques discussed previously assume that durations of activities are generally independent of each other. A second problem stems from the complexity of construction technologies. In the course of resource allocations, numerous additional constraints or objectives may exist that are difficult to represent analytically. For example, different workers may have specialized in one type of activity or another. With greater experience, the work efficiency for particular crews may substantially increase. Unfortunately, representing such effects in the scheduling process can be very difficult. Another case of complexity occurs when activity durations and schedules are negotiated among the different parties in a project so there is no single overall planner.

A practical approach to these types of concerns is to insure that all schedules are reviewed and modified by experienced project managers before implementation. This manual review permits the incorporation of global constraints or consideration of peculiarities of workers and equipment. Indeed, interactive schedule revision to accommodate resource constraints is often superior to any computer based heuristic. With improved graphic representations and information availability, man-machine interaction is likely to improve as a scheduling procedure.

More generally, the solution procedures for scheduling in these more complicated situations cannot be reduced to mathematical algorithms. The best solution approach is likely to be a "generate-and-test" cycle for alternative plans and schedules. In this process, a possible schedule is hypothesized or generated. This schedule is tested for feasibility with respect to relevant constraints (such as available resources or time horizons) and desirability with respect to different objectives. Ideally, the process of evaluating an alternative will suggest directions for improvements or identify particular trouble spots. These results are then used in the generation

of a new test alternative. This process continues until a satisfactory plan is obtained.

Two important problems must be borne in mind in applying a "generate-and-test" strategy. First, the number of possible plans and schedules is enormous, so considerable insight to the problem must be used in generating reasonable alternatives. Secondly, evaluating alternatives also may involve considerable effort and judgment. As a result, the number of actual cycles of alternative testing that can be accommodated is limited. One hope for computer technology in this regard is that the burdensome calculations associated with this type of planning may be assumed by the computer, thereby reducing the cost and required time for the planning effort. Some mechanisms along these lines are described in Chapter 15.

#### Example 11-9: Man-machine Interactive Scheduling

An interactive system for scheduling with resource constraints might have the following characteristics: [9]

- graphic displays of bar charts, resource use over time, activity networks and other graphic images available in different windows of a screen simultaneously,
- descriptions of particular activities including allocated resources and chosen technologies available in windows as desired by a user,
- a three dimensional animation of the construction process that can be stopped to show the progress of construction on the facility at any time,
- easy-to-use methods for changing start times and allocated resources, and
- utilities to run relevant scheduling algorithms such as the critical path method at any time.

Figure 11-6 shows an example of a screen for this system. In Figure 11-6, a bar chart appears in one window, a description of an activity in another window, and a graph of the use of a particular resource over time appears in a third window. These different "windows" appear as sections on a computer screen displaying different types of information. With these capabilities, a project manager can call up different pictures of the construction plan and make changes to accommodate objectives or constraints that are not formally represented. With rapid response to such changes, the effects can be immediately evaluated.

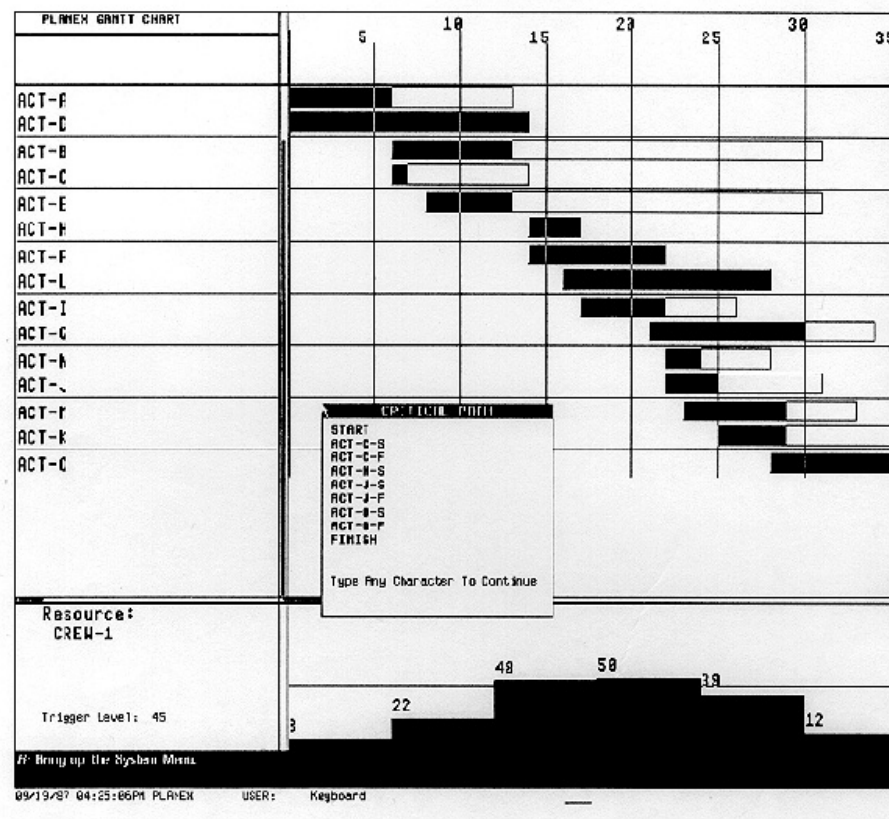

Figure 11-6 Example of a Bar Chart and Other Windows for Interactive Scheduling

[Back to top](#)

## 11.6 Improving the Scheduling Process

Despite considerable attention by researchers and practitioners, the process of construction planning and scheduling still presents problems and opportunities for improvement. The importance of scheduling in insuring the effective coordination of work and the attainment of project deadlines is indisputable. For large projects with many parties involved, the use of formal schedules is indispensable.

The network model for representing project activities has been provided as an important conceptual and computational framework for planning and scheduling. Networks not only communicate the basic precedence relationships between activities, they also form the basis for most scheduling computations.

As a practical matter, most project scheduling is performed with the critical path scheduling method, supplemented by heuristic procedures used in project crash analysis or resource constrained scheduling. Many commercial software programs are available to perform these tasks. Probabilistic scheduling or the use of optimization software to perform time/cost trade-offs is rather more infrequently applied, but there are software programs available to perform these tasks if desired.

Rather than concentrating upon more elaborate solution algorithms, the most important innovations in construction scheduling are likely to appear in the areas of data storage, ease of use, data representation, communication and diagnostic or interpretation aids. Integration of scheduling information with accounting and design information through the means of database systems is one beneficial innovation; many scheduling systems do not provide such integration of information. The techniques discussed in Chapter 14 are particularly useful in this regard.

With regard to ease of use, the introduction of interactive scheduling systems, graphical output devices and automated data acquisition should produce a very different environment than has existed. In the past, scheduling was performed as a batch operation with output contained in lengthy tables of numbers. Updating of work progress and revising activity duration was a time consuming manual task. It is no surprise that managers viewed scheduling as extremely burdensome in this environment. The lower costs associated with computer systems as well as improved software make "user friendly" environments a real possibility for field operations on large projects.

Finally, information representation is an area which can result in substantial improvements. While the network model of project activities is an extremely useful device to represent a project, many aspects of project plans and activity inter-relationships cannot or have not been represented in network models. For example, the similarity of processes among different activities is usually unrecorded in the formal project representation. As a result, updating a project network in response to new information about a process such as concrete pours can be tedious. What is needed is a much more flexible and complete representation of project information. Some avenues for change along these lines are discussed in Chapter 15.

[Back to top](#)

## 11.7 References

1. Bratley, Paul, Bennett L. Fox and Linus E. Schrage, *A Guide to Simulation*, Springer-Verlag, 1973.
2. Elmaghraby, S.E., *Activity Networks: Project Planning and Control by Network Models*, John Wiley, New York, 1977.
3. Jackson, M.J., *Computers in Construction Planning and Control*, Allen & Unwin, London, 1986.
4. Moder, J., C. Phillips and E. Davis, *Project Management with CPM, PERT and Precedence Diagramming*, Third Edition, Van Nostrand Reinhold Company, 1983.

[Back to top](#)

## 11.8 Problems

1. For the project defined in Problem 1 from Chapter 10, suppose that the early, most likely and late time schedules are desired. Assume that the activity durations are approximately normally distributed with means as given in Table 10-16 and the following standard deviations: A: 4; B: 10; C: 1; D: 15; E: 6; F: 12; G: 9; H: 2; I: 4; J: 5; K: 1; L: 12; M: 2; N: 1; O: 5. (a) Find the early, most likely and late time schedules, and (b) estimate the probability that the project requires 25% more time than the expected duration.
2. For the project defined in Problem 2 from Chapter 10, suppose that the early, most likely and late time schedules are desired. Assume that the activity durations are approximately normally distributed with means as given in Table 10-17 and the following standard deviations: A: 2, B: 2, C: 1, D: 0, E: 0, F: 2; G: 0, H: 0, I: 0, J: 3; K: 0, L: 3; M: 2; N: 1. (a) Find the early, most likely and late time schedules, and (b) estimate the probability that the project requires 25% more time than the expected

duration.

3 to 6

The time-cost tradeoff data corresponding to each of the Problems 1 to 4 (in Chapter 10), respectively are given in the table for the problem (Tables 11-5 to 11-8). Determine the all-crash and the project crash durations and cost based on the early time schedule for the project. Also, suggest a combination of activity durations which will lead to a project completion time equal to three days longer than the project crash time but would result in the (approximately) maximum savings.

**TABLE 11-5**

Activity	A	B	C	D	E	F	G	H	I	J	K	L	M	N	O
Shortest Possible Completion Time	3	5	1	10	4	6	6	2	4	3	3	3	2	2	5
Normal Completion Time Cost	150	250	80	400	220	300	260	120	200	180	220	500	100	120	500
Change in Cost Per Day Earlier Completion	20	30	Infinity	15	20	25	10	35	20	Infinity	25	15	30	Infinity	10

**TABLE 11-6**

Activity	A	B	C	D	E	F	G	H	I	J	K	L	M	N
Shortest Possible Completion Time	2	4	1	3	3	5	2	1	2	6	1	4	3	2
Normal Completion Time Cost	400	450	200	300	350	550	250	180	150	480	120	500	280	220
Crash Completion Time Cost	460	510	250	350	430	640	300	250	150	520	150	560	320	260

**TABLE 11-7**

Activity	A	B	C	D	E	F	G	H	I	J	K	L
Shortest Possible Completion Time	4	8	11	4	1	9	6	2	3	2	7	3
Normal Completion Time Cost	70	150	200	60	40	120	100	50	70	60	120	70
Crash Completion Time Cost	90	210	250	80	60	140	130	70	90	80	150	100

**TABLE 11-8**

Activity	A	B	C	D	E	F	G	H	I	J	K	L	M
Shortest Possible Completion Time	3	5	2	2	5	3	5	6	6	4	5	2	2
Normal Completion Time Cost	50	150	90	125	300	240	80	270	120	600	300	80	140
Change in Cost Per Day Earlier Completion	Infinity	50	Infinity	40	30	20	15	30	Infinity	40	50	40	40

7 to 10

Develop a project completion time versus cost tradeoff curve for the projects in Problems 3 to 6. (Note: a linear programming computer program or more specialized programs can reduce the calculating work involved in these problems!)

- Suppose that the project described in Problem 5 from Chapter 10 proceeds normally on an earliest time schedule with all activities scheduled for their normal completion time. However, suppose that activity G requires 20 days rather than the expected 5. What might a project manager do to insure completion of the project by the originally planned completion time?
- For the project defined in Problem 1 from Chapter 10, suppose that a Monte Carlo simulation with ten repetitions is desired. Suppose further that the activity durations have a triangular distribution with the following lower and upper bounds: A:4,8; B:4,9; C: 0.5,2; D: 10,20; E: 4,7; F: 7,10; G: 8, 12; H: 2,4; I: 4,7; J: 2,4; K: 2,6; L: 10, 15; M: 2,9; N: 1,4; O: 4,11.
  - Calculate the value of m for each activity given the upper and lower bounds and the expected duration shown in Table 10-16.
  - Generate a set of realizations for each activity and calculate the resulting project duration.

(c) Repeat part (b) five times and estimate the mean and standard deviation of the project duration.

13. Suppose that two variables both have triangular distributions and are correlated. The resulting multi-variable probability density function has a triangular shape. Develop the formula for the conditional distribution of one variable given the corresponding realization of the other variable.

[Back to top](#)

## 11.9 Footnotes

1. See D. G. Malcolm, J.H. Rosenbloom, C.E. Clark, and W. Fazar, "Applications of a Technique for R and D Program Evaluation," *Operations Research*, Vol. 7, No. 5, 1959, pp. 646-669. [Back](#)
2. See M.W. Sasieni, "A Note on PERT Times," *Management Science*, Vol. 32, No. 12, p 1986, p. 1652-1653, and T.K. Littlefield and P.H. Randolph, "An Answer to Sasieni's Question on Pert Times," *Management Science*, Vol. 33, No. 10, 1987, pp. 1357-1359. For a general discussion of the Beta distribution, see N.L. Johnson and S. Kotz, *Continuous Univariate Distributions-2*, John Wiley & Sons, 1970, Chapter 24. [Back](#)
3. See T. Au, R.M. Shane, and L.A. Hoel, *Fundamentals of Systems Engineering - Probabilistic Models*, Addison-Wesley Publishing Company, 1972. [Back](#)
4. See N.L. Johnson and S. Kotz, *Distributions in Statistics: Continuous Multivariate Distributions*, John Wiley & Sons, New York, 1973. [Back](#)
5. See, for example, P. Bratley, B. L. Fox and L.E. Schrage, *A Guide to Simulation*, Springer-Verlag, New York, 1983. [Back](#)
6. There are exceptions to this rule, though. More workers may also mean additional training burdens and more problems of communication and management. Some activities cannot be easily broken into tasks for numerous individuals; some aspects of computer programming provide notable examples. Indeed, software programming can be so perverse that examples exist of additional workers resulting in slower project completion. See F.P. Brooks, jr. , *The Mythical Man-Month*, Addison Wesley, Reading, MA 1975. [Back](#)
7. For a discussion of solution procedures and analogies of the general function time/cost tradeoff problem, see C. Hendrickson and B.N. Janson, "A Common Network Flow Formulation for Several Civil Engineering Problems," *Civil Engineering Systems*, Vol. 1, No. 4, 1984, pp. 195-203. [Back](#)
8. This example was abstracted from work performed in Houston and reported in U. Officer, "Using Accelerated Contracts with Incentive Provisions for Transitway Construction in Houston," Paper Presented at the January 1986 Transportation Research Board Annual Conference, Washington, D.C. [Back](#)
9. This description is based on an interactive scheduling system developed at Carnegie Mellon University and described in C. Hendrickson, C. Zozaya-Gorostiza, D. Rehak, E. Baracco-Miller and P. Lim, "An Expert System for Construction Planning," *ASCE Journal of Computing*, Vol. 1, No. 4, 1987, pp. 253-269. [Back](#)

[Previous Chapter](#) | [Table of Contents](#) | [Next Chapter](#)

<a href="#">Go Up to Table of Contents</a>	
<a href="#">Go To Chapter 11 (Advanced Scheduling Techniques)</a>	<a href="#">Go To Chapter 13 (Quality Control and Safety During Construction)</a>
<i>Cost Control, Monitoring and Accounting</i> <a href="#">The Cost Control Problem</a> <a href="#">The Project Budget</a> <a href="#">Forecasting for Activity Cost Control</a> <a href="#">Financial Accounting Systems and Cost Accounts</a> <a href="#">Control of Project Cash Flows</a> <a href="#">Schedule Control</a> <a href="#">Schedule and Budget Updates</a> <a href="#">Relating Cost and Schedule Information</a> <a href="#">References</a> <a href="#">Problems</a> <a href="#">Footnotes</a>	

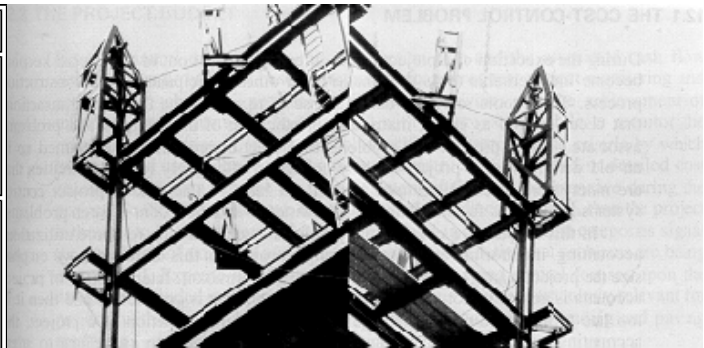

[http://pmbook.ce.cmu.edu/12\\_Cost\\_Control,\\_Monitoring,\\_and\\_Accounting.html](http://pmbook.ce.cmu.edu/12_Cost_Control,_Monitoring,_and_Accounting.html)

## 12. Cost Control, Monitoring and Accounting

### 12.1 The Cost Control Problem

During the execution of a project, procedures for project control and record keeping become indispensable tools to managers and other participants in the construction process. These tools serve the dual purpose of recording the financial transactions that occur as well as giving managers an indication of the progress and problems associated with a project. The problems of project control are aptly summed up in an old definition of a project as "any collection of vaguely related activities that are ninety percent complete, over budget and late." [1] The task of project control systems is to give a fair indication of the existence and the extent of such problems.

In this chapter, we consider the problems associated with resource utilization, accounting, monitoring and control during a project. In this discussion, we emphasize the project management uses of accounting information. Interpretation of project accounts is generally not straightforward until a project is completed, and then it is too late to influence project management. Even after completion of a project, the accounting results may be confusing. Hence, managers need to know how to interpret accounting information for the purpose of project management. In the process of considering management problems, however, we shall discuss some of the common accounting systems and conventions, although our purpose is not to provide a comprehensive survey of accounting procedures.

The limited objective of project control deserves emphasis. Project control procedures are primarily intended to identify deviations from the project plan rather than to suggest possible areas for cost savings. This characteristic reflects the advanced stage at which project control becomes important. The time at which major cost savings can be achieved is during planning and design for the project. During the actual construction, changes are likely to delay the project and lead to inordinate cost increases. As a result, the focus of project control is on fulfilling the original design plans or indicating deviations from these plans, rather than on searching for significant improvements and cost savings. It is only when a rescue operation is required that major changes will normally occur in the construction plan.

Finally, the issues associated with integration of information will require some discussion. Project management activities and functional concerns are intimately linked, yet the techniques used in many instances do not facilitate comprehensive or integrated consideration of project activities. For example, schedule information and cost accounts are usually kept separately. As a result, project managers themselves must synthesize a comprehensive view from the different reports on the project plus their own field observations. In particular, managers are often forced to infer the cost impacts of schedule changes, rather than being provided with aids for this process.

Communication or integration of various types of information can serve a number of useful purposes, although it does require special attention in the establishment of project control procedures.

[Back to top](#)

## 12.2 The Project Budget

For cost control on a project, the construction plan and the associated cash flow estimates can provide the baseline reference for subsequent project monitoring and control. For schedules, progress on individual activities and the achievement of milestone completions can be compared with the project schedule to monitor the progress of activities. Contract and job specifications provide the criteria by which to assess and assure the required quality of construction. The final or detailed cost estimate provides a baseline for the assessment of financial performance during the project. To the extent that costs are within the detailed cost estimate, then the project is thought to be under *financial control*. Overruns in particular cost categories signal the possibility of problems and give an indication of exactly what problems are being encountered. Expense oriented construction planning and control focuses upon the categories included in the final cost estimation. This focus is particularly relevant for projects with few activities and considerable repetition such as grading and paving roadways.

For control and monitoring purposes, the original detailed cost estimate is typically converted to a *project budget*, and the project budget is used subsequently as a guide for management. Specific items in the detailed cost estimate become job cost elements. Expenses incurred during the course of a project are recorded in specific job cost accounts to be compared with the original cost estimates in each category. Thus, individual job cost accounts generally represent the basic unit for cost control. Alternatively, job cost accounts may be disaggregated or divided into *work elements* which are related both to particular scheduled activities and to particular cost accounts. Work element divisions will be described in Section 12.8.

In addition to cost amounts, information on material quantities and labor inputs within each job account is also typically retained in the project budget. With this information, actual materials usage and labor employed can be compared to the expected requirements. As a result, cost overruns or savings on particular items can be identified as due to changes in unit prices, labor productivity or in the amount of material consumed.

The number of cost accounts associated with a particular project can vary considerably. For constructors, on the order of four hundred separate cost accounts might be used on a small project. [2] These accounts record all the transactions associated with a project. Thus, separate accounts might exist for different types of materials, equipment use, payroll, project office, etc. Both physical and non-physical resources are represented, including overhead items such as computer use or interest charges. Table 12-1 summarizes a typical set of cost accounts that might be used in building construction. [3] Note that this set of accounts is organized hierarchically, with seven major divisions (accounts 201 to 207) and numerous sub-divisions under each division. This hierarchical structure facilitates aggregation of costs into pre-defined categories; for example, costs associated with the superstructure (account 204) would be the sum of the underlying subdivisions (ie. 204.1, 204.2, etc.) or finer levels of detail (204.61, 204.62, etc.). The sub-division accounts in Table 12-1 could be further divided into personnel, material and other resource costs for the purpose of financial accounting, as described in Section 12.4.

**TABLE 12-1** Illustrative Set of Project Cost Accounts

201	Clearing and Preparing Site
202	Substructure
202.1	Excavation and Shoring
202.2	Piling
202.3	Concrete Masonry
202.31	Mixing and Placing
202.32	Formwork
202.33	Reinforcing

203	Outside Utilities (water, gas, sewer, etc.)
204	Superstructure
204.1	Masonry Construction
204.2	Structural Steel
204.3	Wood Framing, Partitions, etc.
204.4	Exterior Finishes (brickwork, terra cotta, cut stone, etc.)
204.5	Roofing, Drains, Gutters, Flashing, etc.
204.6	Interior Finish and Trim
204.61	Finish Flooring, Stairs, Doors, Trim
204.62	Glass, Windows, Glazing
204.63	Marble, Tile, Terrazzo
204.64	Lathing and Plastering
204.65	Soundproofing and Insulation
204.66	Finish Hardware
204.67	Painting and Decorating
204.68	Waterproofing
204.69	Sprinklers and Fire Protection
204.7	Service Work
204.71	Electrical Work
204.72	Heating and Ventilating
204.73	Plumbing and Sewage
204.74	Air Conditioning
204.72	Fire Alarm, Telephone, Security, Miscellaneous
205	Paving, Curbs, Walks
206	Installed Equipment (elevators, revolving doors, mailchutes, etc.)
207	Fencing

In developing or implementing a system of cost accounts, an appropriate numbering or coding system is essential to facilitate communication of information and proper aggregation of cost information. Particular cost accounts are used to indicate the expenditures associated with specific projects and to indicate the expenditures on particular items throughout an organization. These are examples of different *perspectives* on the same information, in which the same information may be summarized in different ways for specific purposes. Thus, more than one aggregation of the cost information and more than one application program can use a particular cost account. Separate identifiers of the type of cost account and the specific project must be provided for project cost accounts or for financial transactions. As a result, a standard set of cost codes such as the MASTERFORMAT codes described in Chapter 9 may be adopted to identify cost accounts along with project identifiers and extensions to indicate organization or job specific needs. Similarly the use of databases or, at a minimum, inter-communicating applications programs facilitate access to cost information, as described in Chapter 14.

Converting a final cost estimate into a project budget compatible with an organization's cost accounts is not always a straightforward task. As described in Chapter 5, cost estimates are generally disaggregated into appropriate *functional* or *resource based* project categories. For example, labor and material quantities might be included for each of several physical components of a project. For cost accounting purposes, labor and material quantities are aggregated by type no matter for which physical component they are employed. For example, particular types of workers or materials might be used on numerous different physical components of a facility. Moreover, the categories of cost accounts established within an organization may bear little resemblance to the quantities included in a final cost estimate. This is particularly true when final cost estimates are prepared in accordance with an external reporting requirement rather than in view of the existing cost accounts within an organization.



One particular problem in forming a project budget in terms of cost accounts is the treatment of contingency amounts. These allowances are included in project cost estimates to accommodate unforeseen events and the resulting costs. However, in advance of project completion, the source of contingency expenses is not known. Realistically, a budget accounting item for *contingency allowance* should be established whenever a contingency amount was included in the final cost estimate.

A second problem in forming a project budget is the treatment of inflation. Typically, final cost estimates are formed in terms of real dollars and an item reflecting inflation costs is added on as a percentage or lump sum. This inflation allowance would then be allocated to individual cost items in relation to the actual expected inflation over the period for which costs will be incurred.

### Example 12-1: Project Budget for a Design Office

An example of a small project budget is shown in Table 12-2. This budget might be used by a design firm for a specific design project. While this budget might represent all the work for this firm on the project, numerous other organizations would be involved with their own budgets. In Table 12-2, a summary budget is shown as well as a detailed listing of costs for individuals in the Engineering Division. For the purpose of consistency with cost accounts and managerial control, labor costs are aggregated into three groups: the engineering, architectural and environmental divisions. The detailed budget shown in Table 12-2 applies only to the engineering division labor; other detailed budgets amounts for categories such as supplies and the other work divisions would also be prepared. Note that the salary costs associated with individuals are aggregated to obtain the total labor costs in the engineering group for the project. To perform this aggregation, some means of identifying individuals within organizational groups is required. Accompanying a budget of this nature, some estimate of the actual man-hours of labor required by project task would also be prepared. Finally, this budget might be used for internal purposes alone. In submitting financial bills and reports to the client, overhead and contingency amounts might be combined with the direct labor costs to establish an aggregate billing rate per hour. In this case, the overhead, contingency and profit would represent *allocated costs* based on the direct labor costs.

**TABLE 12-2** Example of a Small Project Budget for a Design Firm

	<b><u>Budget Summary</u></b>
Personnel	
Architectural	
Division	
Engineering	
Environmental	
Division	\$ 67,251.00
Total	45,372.00
	<u>28,235.00</u>
Other Direct	\$140,858.00
Expenses	
Travel	
Supplies	2,400.00
Communication	1,500.00
Computer Services	600.00
Total	<u>1,200.00</u>
	\$ 5,700.00
Overhead	\$ 175,869.60
Contingency and	
Profit	<u>\$ 95,700.00</u>
Total	\$ 418,127.60

<b><u>Engineering Personnel Detail</u></b>	
Senior Engineer	\$ 11,562.00
Associate Engineer	21,365.00
Engineer Technician	<u>12,654.00</u>
Total	\$ 45,372.00

### Example 12-2: Project Budget for a Constructor

Table 12-3 illustrates a summary budget for a constructor. This budget is developed from a project to construct a wharf. As with the example design office budget above, costs are divided into direct and indirect expenses. Within direct costs, expenses are divided into material, subcontract, temporary work and machinery costs. This budget indicates aggregate amounts for the various categories. Cost details associated with particular cost accounts would supplement and support the aggregate budget shown in Table 12-3. A profit and a contingency amount might be added to the basic budget of \$1,715,147 shown in Table 12-3 for completeness.

**TABLE 12-3** An Example of a Project Budget for a Wharf Project (Amounts in Thousands of Dollars)

	Material Cost	Subcontract Work	Temporary Work	Machinery Cost	Total Cost
Steel Piling	\$292,172	\$129,178	\$16,389	\$0	\$437,739
Tie-rod	88,233	29,254	0	0	117,487
Anchor-Wall	130,281	60,873	0	0	191,154
Backfill	242,230	27,919	0	0	300,149
Coping	42,880	22,307	13,171	0	78,358
Dredging	0	111,650	0	0	111,650
Fender	48,996	10,344	0	1,750	61,090
Other	<u>5,000</u>	<u>32,250</u>	<u>0</u>	<u>0</u>	<u>37,250</u>
Sub-total	\$849,800	\$423,775	\$29,560	\$1,750	\$1,304,885
<b>Summary</b>					
Total of direct cost					\$1,304,885
Indirect Cost					
Common Temporary Work					19,320
Common Machinery					80,934
Transportation					15,550
Office Operating Costs					294,458
Total of Indirect Cost					<u>410,262.</u>
Total Project Cost					\$1,715,147

[Back to top](#)

## 12.3 Forecasting for Activity Cost Control

For the purpose of project management and control, it is not sufficient to consider only the past record of costs and revenues incurred in a project. Good managers should focus upon future revenues, future costs and technical problems. For this purpose, traditional financial accounting schemes are not adequate to reflect the dynamic nature of a project. Accounts typically focus on recording routine costs and past expenditures associated with activities.

[4] Generally, past expenditures represent *sunk costs* that cannot be altered in the future and may or may not be relevant in the future. For example, after the completion of some activity, it may be discovered that some quality

flaw renders the work useless. Unfortunately, the resources expended on the flawed construction will generally be *sunk* and cannot be recovered for re-construction (although it may be possible to change the burden of who pays for these resources by financial withholding or charges; owners will typically attempt to have constructors or designers pay for changes due to quality flaws). Since financial accounts are historical in nature, some means of forecasting or projecting the future course of a project is essential for management control. In this section, some methods for cost control and simple forecasts are described.

An example of forecasting used to assess the project status is shown in Table 12-4. In this example, costs are reported in five categories, representing the sum of all the various cost accounts associated with each category:

- **Budgeted Cost**

The budgeted cost is derived from the detailed cost estimate prepared at the start of the project. Examples of project budgets were presented in Section 12.2. The factors of cost would be referenced by cost account and by a prose description.

- **Estimated total cost**

The estimated or forecast total cost in each category is the current best estimate of costs based on progress and any changes since the budget was formed. Estimated total costs are the sum of cost to date, commitments and exposure. Methods for estimating total costs are described below.

- **Cost Committed and Cost Exposure!!** Estimated cost to completion in each category is divided into firm commitments and estimated additional cost or *exposure*. Commitments may represent material orders or subcontracts for which firm dollar amounts have been committed.

- **Cost to Date**

The actual cost incurred to date is recorded in column 6 and can be derived from the financial record keeping accounts.

- **Over or (Under)**

A final column in Table 12-4 indicates the amount over or under the budget for each category. This column is an indicator of the extent of variance from the project budget; items with unusually large overruns would represent a particular managerial concern. Note that *variance* is used in the terminology of project control to indicate a difference between budgeted and actual expenditures. The term is defined and used quite differently in statistics or mathematical analysis. In Table 12-4, labor costs are running higher than expected, whereas subcontracts are less than expected.

The current status of the project is a forecast budget overrun of \$5,950. with 23 percent of the budgeted project costs incurred to date.

**TABLE 12-4** Illustration of a Job Status Report

Factor	Budgeted Cost	Estimated Total Cost	Cost Committed	Cost Exposure	Cost To Date	Over or (Under)
Labor	\$99,406	\$102,342	\$49,596	---	\$52,746	\$2,936
Material	88,499	88,499	42,506	45,993	---	0
Subcontracts	198,458	196,323	83,352	97,832	15,139	(2,135)
Equipment	37,543	37,543	23,623	---	13,920	0
Other	72,693	81,432	49,356	---	32,076	8,739
Total	496,509	506,139	248,433	143,825	113,881	5,950

For project control, managers would focus particular attention on items indicating substantial deviation from budgeted amounts. In particular, the cost overruns in the labor and in the "other expense category would be worthy of attention by a project manager in Table 12-4. A next step would be to look in greater detail at the various components of these categories. Overruns in cost might be due to lower than expected productivity, higher than expected wage rates, higher than expected material costs, or other factors. Even further, low productivity might be caused by inadequate training, lack of required resources such as equipment or tools, or inordinate amounts of re-work to correct quality problems. Review of a job status report is only the first step in project control.

The job status report illustrated in Table 12-4 employs explicit estimates of ultimate cost in each category of

expense. These estimates are used to identify the actual progress and status of a expense category. Estimates might be made from simple linear extrapolations of the productivity or cost of the work to date on each project item. Algebraically, a linear estimation formula is generally one of two forms. Using a linear extrapolation of costs, the forecast total cost,  $C_f$ , is:

$$(12.1) \quad C_f = \frac{C_t}{P_t}$$

where  $C_t$  is the cost incurred to time  $t$  and  $p_t$  is the proportion of the activity completed at time  $t$ . For example, an activity which is 50 percent complete with a cost of \$40,000 would be estimated to have a total cost of  $\$40,000/0.5 = \$80,000$ . More elaborate methods of forecasting costs would disaggregate costs into different categories, with the total cost the sum of the forecast costs in each category.

Alternatively, the use of measured unit cost amounts can be used for forecasting total cost. The basic formula for forecasting cost from unit costs is:

$$(12.2) \quad C_f = Wc_t$$

where  $C_f$  is the forecast total cost,  $W$  is the total units of work, and  $c_t$  is the average cost per unit of work experienced up to time  $t$ . If the average unit cost is \$50 per unit of work on a particular activity and 1,600 units of work exist, then the expected cost is  $(1,600)(50) = \$80,000$  for completion.

The unit cost in Equation (12.2) may be replaced with the hourly productivity and the unit cost per hour (or other appropriate time period), resulting in the equation:

$$(12.3) \quad C_f = Wh_tu_t$$

where the cost per work unit ( $c_t$ ) is replaced by the time per unit,  $h_t$ , divided by the cost per unit of time,  $u_t$ .

More elaborate forecasting systems might recognize peculiar problems associated with work on particular items and modify these simple proportional cost estimates. For example, if productivity is improving as workers and managers become more familiar with the project activities, the estimate of total costs for an item might be revised downward. In this case, the estimating equation would become:

$$(12.4) \quad C_f = C_t + (W - W_t)c_t$$

where forecast total cost,  $C_f$ , is the sum of cost incurred to date,  $C_t$ , and the cost resulting from the remaining work  $(W - W_t)$  multiplied by the expected cost per unit time period for the remainder of the activity,  $c_t$ .

As a numerical example, suppose that the average unit cost has been \$50 per unit of work, but the most recent figure during a project is \$45 per unit of work. If the project manager was assured that the improved productivity could be maintained for the remainder of the project (consisting of 800 units of work out of a total of 1600 units of work), the cost estimate would be  $(50)(800) + (45)(800) = \$76,000$  for completion of the activity. Note that this forecast uses the actual average productivity achieved on the first 800 units and uses a forecast of productivity for the remaining work. Historical changes in productivity might also be used to represent this type of non-linear changes in work productivity on particular activities over time.

In addition to changes in productivities, other components of the estimating formula can be adjusted or more detailed estimates substituted. For example, the change in unit prices due to new labor contracts or material

supplier's prices might be reflected in estimating future expenditures. In essence, the same problems encountered in preparing the detailed cost estimate are faced in the process of preparing exposure estimates, although the number and extent of uncertainties in the project environment decline as work progresses. The only exception to this rule is the danger of quality problems in completed work which would require re-construction.

Each of the estimating methods described above require current information on the state of work accomplishment for particular activities. There are several possible methods to develop such estimates, including [5]:

- **Units of Work Completed**

For easily measured quantities the actual proportion of completed work amounts can be measured. For example, the linear feet of piping installed can be compared to the required amount of piping to estimate the percentage of piping work completed.

- **Incremental Milestones**

Particular activities can be sub-divided or "decomposed" into a series of milestones, and the milestones can be used to indicate the percentage of work complete based on historical averages. For example, the work effort involved with installation of standard piping might be divided into four milestones:

- Spool in place: 20% of work and 20% of cumulative work.
- Ends welded: 40% of work and 60% of cumulative work.
- Hangars and Trim Complete: 30% of work and 90% of cumulative work.
- Hydrotested and Complete: 10% of work and 100% of cumulative work.

Thus, a pipe section for which the ends have been welded would be reported as 60% complete.

- **Opinion**

Subjective judgments of the percentage complete can be prepared by inspectors, supervisors or project managers themselves. Clearly, this estimated technique can be biased by optimism, pessimism or inaccurate observations. Knowledgeable estimators and adequate field observations are required to obtain sufficient accuracy with this method.

- **Cost Ratio**

The cost incurred to date can also be used to estimate the work progress. For example, if an activity was budgeted to cost \$20,000 and the cost incurred at a particular date was \$10,000, then the estimated percentage complete under the cost ratio method would be  $10,000/20,000 = 0.5$  or fifty percent. This method provides no independent information on the actual percentage complete or any possible errors in the activity budget: the cost forecast will always be the budgeted amount. Consequently, managers must use the estimated costs to complete an activity derived from the cost ratio method with extreme caution.

Systematic application of these different estimating methods to the various project activities enables calculation of the percentage complete or the productivity estimates used in preparing job status reports.

In some cases, automated data acquisition for work accomplishments might be instituted. For example, transponders might be moved to the new work limits after each day's activity and the new locations automatically computed and compared with project plans. These measurements of actual progress should be stored in a central database and then processed for updating the project schedule. The use of database management systems in this fashion is described in Chapter 14.

### **Example 12-3: Estimated Total Cost to Complete an Activity**

Suppose that we wish to estimate the total cost to complete piping construction activities on a project. The piping construction involves 1,000 linear feet of piping which has been divided into 50 sections for management convenience. At this time, 400 linear feet of piping has been installed at a cost of \$40,000 and 500 man-hours of labor. The original budget estimate was \$90,000 with a productivity of one foot per man-hour, a unit cost of \$60 per man hour and a total material cost of \$30,000. Firm commitments of material delivery for the \$30,000 estimated cost have been received.

The first task is to estimate the proportion of work completed. Two estimates are readily available. First, 400 linear feet of pipe is in place out of a total of 1000 linear feet, so the proportion of work

completed is  $400/1000 = 0.4$  or 40%. This is the "units of work completed" estimation method. Second, the cost ratio method would estimate the work complete as the cost-to-date divided by the cost estimate or  $\$40,000/\$90,000 = 0.44$  or 44%. Third, the "incremental milestones" method would be applied by examining each pipe section and estimating a percentage complete and then aggregating to determine the total percentage complete. For example, suppose the following quantities of piping fell into four categories of completeness:

complete (100%)	380 ft
hangars and trim complete (90%)	20 ft
ends welded (60%)	5 ft
spool in place (20%)	0 ft

Then using the incremental milestones shown above, the estimate of completed work would be  $380 + (20)(0.9) + (5)(0.6) + 0 = 401$  ft and the proportion complete would be  $401 \text{ ft}/1,000 \text{ ft} = 0.401$  or 40% after rounding.

Once an estimate of work completed is available, then the estimated cost to complete the activity can be calculated. First, a simple linear extrapolation of cost results in an estimate of  $\$40,000/0.4 = \$100,000$  for the piping construction using the 40% estimate of work completed. This estimate projects a cost overrun of  $100,000 - 90,000 = \$10,000$ .

Second, a linear extrapolation of productivity results in an estimate of  $(1000 \text{ ft.})(500 \text{ hrs}/400 \text{ ft.}) (\$60/\text{hr}) + 30,000 = \$105,000$  for completion of the piping construction. This estimate suggests a variance of  $105,000 - 90,000 = \$15,000$  above the activity estimate. In making this estimate, labor and material costs entered separately, whereas the two were implicitly combined in the simple linear cost forecast above. The source of the variance can also be identified in this calculation: compared to the original estimate, the labor productivity is 1.25 hours per foot or 25% higher than the original estimate.

#### Example 12-4: Estimated Total Cost for Completion

The forecasting procedures described above assumed linear extrapolations of future costs, based either on the complete experience on the activity or the recent experience. For activities with good historical records, it can be the case that a typically non-linear profile of cost expenditures and completion proportions can be estimated. Figure 12-1 illustrates one possible non-linear relationships derived from experience in some particular activity. The progress on a new job can be compared to this historical record. For example, point A in Figure 12-1 suggests a higher expenditure than is normal for the completion proportion. This point represents 40% of work completed with an expenditure of 60% of the budget. Since the historical record suggests only 50% of the budget should be expended at time of 40% completion, a  $60 - 50 = 10\%$  overrun in cost is expected even if work efficiency can be increased to historical averages. If comparable cost overruns continue to accumulate, then the cost-to-complete will be even higher.

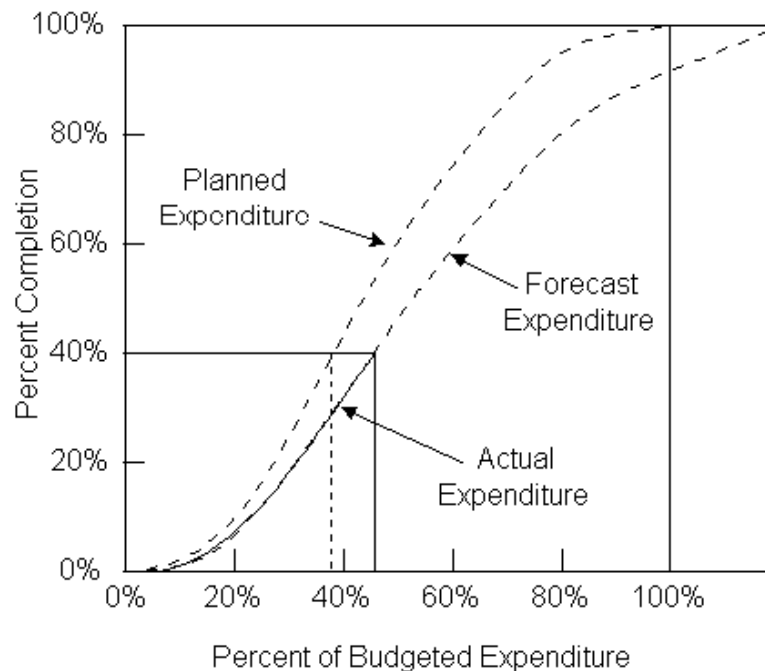

**Figure 12-1** Illustration of Proportion Completion versus Expenditure for an Activity

[Back to top](#)

## 12.4 Financial Accounting Systems and Cost Accounts

The cost accounts described in the previous sections provide only one of the various components in a financial accounting system. Before further discussing the use of cost accounts in project control, the relationship of project and financial accounting deserves mention. Accounting information is generally used for three distinct purposes:

- Internal reporting to project managers for day-to-day planning, monitoring and control.
- Internal reporting to managers for aiding strategic planning.
- External reporting to owners, government, regulators and other outside parties.

External reports are constrained to particular forms and procedures by contractual reporting requirements or by generally accepted accounting practices. Preparation of such external reports is referred to as *financial accounting*. In contrast, *cost* or *managerial* accounting is intended to aid internal managers in their responsibilities of planning, monitoring and control.

Project costs are always included in the system of financial accounts associated with an organization. At the heart of this system, all expense transactions are recorded in a general ledger. The general ledger of accounts forms the basis for management reports on particular projects as well as the financial accounts for an entire organization. Other components of a financial accounting system include:

- The **accounts payable** journal is intended to provide records of bills received from vendors, material suppliers, subcontractors and other outside parties. Invoices of charges are recorded in this system as are checks issued in payment. Charges to individual cost accounts are relayed or *posted* to the General Ledger.
- **Accounts receivable journals** provide the opposite function to that of accounts payable. In this journal, billings to clients are recorded as well as receipts. Revenues received are relayed to the general ledger.
- **Job cost ledgers** summarize the charges associated with particular projects, arranged in the various cost accounts used for the project budget.

- **Inventory** records are maintained to identify the amount of materials available at any time.

In traditional bookkeeping systems, day to day transactions are first recorded in journals. With double-entry bookkeeping, each transaction is recorded as both a debit and a credit to particular accounts in the ledger. For example, payment of a supplier's bill represents a debit or increase to a project cost account and a credit or reduction to the company's cash account. Periodically, the transaction information is summarized and transferred to ledger accounts. This process is called *posting*, and may be done instantaneously or daily in computerized systems.

In reviewing accounting information, the concepts of *flows* and *stocks* should be kept in mind. Daily transactions typically reflect flows of dollar amounts entering or leaving the organization. Similarly, use or receipt of particular materials represent flows from or to inventory. An account balance represents the *stock* or cumulative amount of funds resulting from these daily flows. Information on both flows and stocks are needed to give an accurate view of an organization's state. In addition, forecasts of future changes are needed for effective management.

Information from the general ledger is assembled for the organization's financial reports, including balance sheets and income statements for each period. These reports are the basic products of the financial accounting process and are often used to assess the performance of an organization. Table 12-5 shows a typical income statement for a small construction firm, indicating a net profit of \$ 330,000 after taxes. This statement summarizes the flows of transactions within a year. Table 12-6 shows the comparable balance sheet, indicated a net increase in retained earnings equal to the net profit. The balance sheet reflects the effects of income flows during the year on the overall worth of the organization.

**TABLE 12-5** Illustration of an Accounting Statement of Income

<b>Income Statement</b> for the year ended December 31, 19xx	
Gross project revenues	\$7,200,000
Direct project costs on contracts	5,500,000
Depreciation of equipment	200,000
Estimating	150,000
Administrative and other expenses	650,000
Subtotal of cost and expenses	6,500,000
Operating Income	700,000
Interest Expense, net	150,000
Income before taxes	550,000
Income tax	220,000
Net income after tax	330,000
Cash dividends	100,000
Retained earnings, current year	230,000
Retention at beginning of year	650,000
Retained earnings at end of year	\$880,000.

**TABLE 12-6** Illustration of an Accounting Balance Sheet

<b>Balance Sheet</b> December 31, 19xx	
Assets	Amount
Cash	\$150,000
Payments Receivable	750,000
Work in progress, not claimed	700,000
Work in progress, retention	200,000



Equipment at cost less accumulated depreciation	1,400,000
Total assets	\$3,200,000
<b>Liabilities and Equity</b>	
Liabilities	
Accounts payable	\$950,000
Other items payable (taxes, wages, etc.)	50,000
Long term debts	500,000
Subtotal	1,500,000
Shareholders' funds	
40,000 shares of common stock (Including paid-in capital)	820,000
Retained Earnings	880,000
Subtotal	1,700,000
Total Liabilities and Equity	\$3,200,000

In the context of private construction firms, particular problems arise in the treatment of uncompleted contracts in financial reports. Under the "completed-contract" method, income is only reported for completed projects. Work on projects underway is only reported on the balance sheet, representing an asset if contract billings exceed costs or a liability if costs exceed billings. When a project is completed, the total net profit (or loss) is reported in the final period as income. Under the "percentage-of-completion" method, actual costs are reported on the income statement plus a proportion of all project revenues (or billings) equal to the proportion of work completed during the period. The proportion of work completed is computed as the ratio of costs incurred to date and the total estimated cost of the project. Thus, if twenty percent of a project was completed in a particular period at a direct cost of \$180,000 and on a project with expected revenues of \$1,000,000, then the contract revenues earned would be calculated as  $\$1,000,000(0.2) = \$200,000$ . This figure represents a profit and contribution to overhead of  $\$200,000 - \$180,000 = \$20,000$  for the period. Note that billings and actual receipts might be in excess or less than the calculated revenues of \$200,000. On the balance sheet of an organization using the percentage-of-completion method, an asset is usually reported to reflect billings and the estimated or calculated earnings in excess of actual billings.

As another example of the difference in the "percentage-of-completion" and the "completed-contract" methods, consider a three year project to construct a plant with the following cash flow for a contractor:

Year	Contract Expenses	Payments Received
1	\$700,000	\$900,000
2	180,000	250,000
3	320,000	150,000
Total	\$1,200,000	\$1,300,000

The supervising architect determines that 60% of the facility is complete in year 1 and 75% in year 2. Under the "percentage-of-completion" method, the net income in year 1 is \$780,000 (60% of \$1,300,000) less the \$700,000 in expenses or \$80,000. Under the "completed-contract" method, the entire profit of \$100,000 would be reported in year 3.

The "percentage-of-completion" method of reporting period earnings has the advantage of representing the actual estimated earnings in each period. As a result, the income stream and resulting profits are less susceptible to precipitate swings on the completion of a project as can occur with the "completed contract method" of calculating income. However, the "percentage-of-completion" has the disadvantage of relying upon estimates which can be manipulated to obscure the actual position of a company or which are difficult to reproduce by outside observers. There are also subtleties such as the deferral of all calculated income from a project until a minimum threshold of the project is completed. As a result, interpretation of the income statement and balance sheet of a private organization is not always straightforward. Finally, there are tax disadvantages from using the "percentage-of-

completion" method since corporate taxes on expected profits may become due during the project rather than being deferred until the project completion. As an example of tax implications of the two reporting methods, a study of forty-seven construction firms conducted by the General Accounting Office found that \$280 million in taxes were deferred from 1980 to 1984 through use of the "completed-contract" method. [6]

It should be apparent that the "percentage-of-completion" accounting provides only a rough estimate of the actual profit or status of a project. Also, the "completed contract" method of accounting is entirely retrospective and provides no guidance for management. This is only one example of the types of allocations that are introduced to correspond to generally accepted accounting practices, yet may not further the cause of good project management. Another common example is the use of equipment depreciation schedules to allocate equipment purchase costs. Allocations of costs or revenues to particular periods within a project may cause severe changes in particular indicators, but have no real meaning for good management or profit over the entire course of a project. As Johnson and Kaplan argue: [7]

Today's management accounting information, driven by the procedures and cycle of the organization's financial reporting system, is too late, too aggregated and too distorted to be relevant for managers' planning and control decisions....

Management accounting reports are of little help to operating managers as they attempt to reduce costs and improve productivity. Frequently, the reports decrease productivity because they require operating managers to spend time attempting to understand and explain reported variances that have little to do with the economic and technological reality of their operations...

The management accounting system also fails to provide accurate product costs. Cost are distributed to products by simplistic and arbitrary measures, usually direct labor based, that do not represent the demands made by each product on the firm's resources.

As a result, complementary procedures to those used in traditional financial accounting are required to accomplish effective project control, as described in the preceding and following sections. While financial statements provide consistent and essential information on the condition of an entire organization, they need considerable interpretation and supplementation to be useful for project management.

#### Example 12-5: Calculating net profit

As an example of the calculation of net profit, suppose that a company began six jobs in a year, completing three jobs and having three jobs still underway at the end of the year. Details of the six jobs are shown in Table 12-7. What would be the company's net profit under, first, the "percentage-of-completion" and, second, the "completed contract method" accounting conventions?

**TABLE 12-7** Example of Financial Records of Projects

<b>Net Profit on Completed Contracts (Amounts in thousands of dollars)</b>				
Job 1			\$1,436	
Job 2			356	
Job 3			<u>- 738</u>	
Total Net Profit on Completed Jobs			\$1,054	
<b>Status of Jobs Underway</b>		Job 4	Job 5	Job 6
Original Contract Price		\$4,200	\$3,800	\$5,630
Contract Changes (Change Orders, etc.)		400	600	- 300
Total Cost to Date		3,600	1,710	620
Payments Received or Due to Date		3,520	1,830	340
Estimated Cost to Complete		500	2,300	5,000

As shown in Table 12-7, a net profit of \$1,054,000 was earned on the three completed jobs. Under the

"completed contract" method, this total would be total profit. Under the percentage-of completion method, the year's expected profit on the projects underway would be added to this amount. For job 4, the expected profits are calculated as follows:

$$\begin{aligned} \text{Current contract price} &= \text{Original contract price} + \text{Contract Changes} \\ &= 4,200 + 400 + 4,600 \\ \text{Credit or debit to date} &= \text{Total costs to date} - \text{Payments received or due to date} \\ &= 3,600 - 3,520 = - 80 \\ \text{Contract value of uncompleted work} &= \text{Current contract price} - \text{Payments received or due} \\ &= 4,600 - 3,520 = 1,080 \\ \text{Credit or debit to come} &= \text{Contract value of uncompleted work} - \text{Estimated Cost to Complete} \\ &= 1,080 - 500 = 580 \\ \text{Estimated final gross profit} &= \text{Credit or debit to date} + \text{Credit or debit to come} \\ &= - 80. + 580. = 500 \\ \text{Estimated total project costs} &= \text{Contract price} - \text{Gross profit} \\ &= 4,600 - 500 = 4,100 \\ \text{Estimated Profit to date} &= \text{Estimated final gross profit} \times \text{Proportion of work complete} \\ &= 500. (3600/4100) = 439 \end{aligned}$$

Similar calculations for the other jobs underway indicate estimated profits to date of \$166,000 for Job 5 and -\$32,000 for Job 6. As a result, the net profit using the "percentage-of-completion" method would be \$1,627,000 for the year. Note that this figure would be altered in the event of multi-year projects in which net profits on projects completed or underway in this year were claimed in earlier periods.

[Back to top](#)

## 12.5 Control of Project Cash Flows

Section 12.3 described the development of information for the control of project costs with respect to the various functional activities appearing in the project budget. Project managers also are involved with assessment of the overall status of the project, including the status of activities, financing, payments and receipts. These various items comprise the project and financing cash flows described in earlier chapters. These components include costs incurred (as described above), billings and receipts for billings to owners (for contractors), payable amounts to suppliers and contractors, financing plan cash flows (for bonds or other financial instruments), etc.

As an example of cash flow control, consider the report shown in Table 12-8. In this case, costs are not divided into functional categories as in Table 12-4, such as labor, material, or equipment. Table 12-8 represents a summary of the project status as viewed from *different components of the accounting system*. Thus, the aggregation of different kinds of cost exposure or cost commitment shown in Table 12-0 has not been performed. The elements in Table 12-8 include:

- **Costs**

This is a summary of charges as reflected by the job cost accounts, including expenditures and estimated costs. This row provides an aggregate summary of the detailed activity cost information described in the previous section. For this example, the total costs as of July 2 (7/02) were \$ 8,754,516, and the original cost estimate was \$65,863,092, so the approximate percentage complete was 8,754,516/65,863,092 or 13.292%. However, the project manager now projects a cost of \$66,545,263 for the project, representing an increase of \$682,171 over the original estimate. This new estimate would reflect the actual percentage of work completed as well as other effects such as changes in unit prices for labor or materials. Needless to say, this increase in expected costs is not a welcome change to the project manager.

- **Billings**

This row summarizes the state of cash flows with respect to the owner of the facility; this row would not be included for reports to owners. The contract amount was \$67,511,602, and a total of \$9,276,621 or 13.741% of the contract has been billed. The amount of allowable billing is specified under the terms of the contract between an owner and an engineering, architect, or constructor. In this case, total billings have exceeded the estimated project completion proportion. The final column includes the currently projected net earnings of \$966,339. This figure is calculated as the contract amount less projected costs:  $67,511,602 - 66,545,263 = \$966,339$ . Note that this profit figure does not reflect the time value of money or discounting.

- **Payables**

The Payables row summarizes the amount owed by the contractor to material suppliers, labor or subcontractors. At the time of this report, \$6,719,103 had been paid to subcontractors, material suppliers, and others. Invoices of \$1,300,089 have accumulated but have not yet been paid. A retention of \$391,671 has been imposed on subcontractors, and \$343,653 in direct labor expenses have been occurred. The total of payables is equal to the total project expenses shown in the first row of costs.

- **Receivables**

This row summarizes the cash flow of receipts from the owner. Note that the actual receipts from the owner may differ from the amounts billed due to delayed payments or retainage on the part of the owner. The net-billed equals the gross billed less retention by the owner. In this case, gross billed is \$9,276,621 (as shown in the billings row), the net billed is \$8,761,673 and the retention is \$514,948. Unfortunately, only \$7,209,344 has been received from the owner, so the open receivable amount is a (substantial!) \$2,067,277 due from the owner.

- **Cash Position**

This row summarizes the cash position of the project as if all expenses and receipts for the project were combined in a single account. The actual expenditures have been \$7,062,756 (calculated as the total costs of \$8,754,516 less subcontractor retentions of \$391,671 and unpaid bills of \$1,300,089) and \$7,209,344 has been received from the owner. As a result, a net cash balance of \$146,588 exists which can be used in an interest earning bank account or to finance deficits on other projects.

Each of the rows shown in Table 12-8 would be derived from different sets of financial accounts. Additional reports could be prepared on the financing cash flows for bonds or interest charges in an overdraft account.

**TABLE 12-8** An Example of a Cash Flow Status Report

Costs 7/02	Charges 8,754,516	Estimated 65,863,092	% Complete 13.292	Projected 66,545,263	Change 682,171
Billings 7/01	Contract 67,511,602	Gross Bill 9,276,621	% Billed 13.741	Profit 966,339	
Payables 7/01	Paid 6,719,103	Open 1,300,089	Retention 391,671	Labor 343,653	<b>Total</b> 8,754,516
Receivable 7/02	Net Bill 8,761,673	Received 7,209,344	Retention 514,948	Open 2,067,277	
Cash Position	Paid 7,062,756	Received 7,209,344	Position 146,588		

The overall status of the project requires synthesizing the different pieces of information summarized in Table 12-8. Each of the different accounting systems contributing to this table provides a different view of the status of the project. In this example, the budget information indicates that costs are higher than expected, which could be troubling. However, a profit is still expected for the project. A substantial amount of money is due from the owner, and this could turn out to be a problem if the owner continues to lag in payment. Finally, the positive cash position for the project is highly desirable since financing charges can be avoided.

The job status reports illustrated in this and the previous sections provide a primary tool for project cost control. Different reports with varying amounts of detail and item reports would be prepared for different individuals involved in a project. Reports to upper management would be summaries, reports to particular staff individuals

would emphasize their responsibilities (eg. purchasing, payroll, etc.), and detailed reports would be provided to the individual project managers. Coupled with scheduling reports described in Chapter 10, these reports provide a snapshot view of how a project is doing. Of course, these schedule and cost reports would have to be tempered by the actual accomplishments and problems occurring in the field. For example, if work already completed is of sub-standard quality, these reports would not reveal such a problem. Even though the reports indicated a project on time and on budget, the possibility of re-work or inadequate facility performance due to quality problems would quickly reverse that rosy situation.

[Back to top](#)

## 12.6 Schedule Control

In addition to cost control, project managers must also give considerable attention to monitoring schedules. Construction typically involves a deadline for work completion, so contractual agreements will force attention to schedules. More generally, delays in construction represent additional costs due to late facility occupancy or other factors. Just as costs incurred are compared to budgeted costs, actual activity durations may be compared to expected durations. In this process, forecasting the time to complete particular activities may be required.

The methods used for forecasting completion times of activities are directly analogous to those used for cost forecasting. For example, a typical estimating formula might be:

$$(12.5) \quad D_f = Wh_t$$

where  $D_f$  is the forecast duration,  $W$  is the amount of work, and  $h_t$  is the observed productivity to time  $t$ . As with cost control, it is important to devise efficient and cost effective methods for gathering information on actual project accomplishments. Generally, observations of work completed are made by inspectors and project managers and then work completed is estimated as described in Section 12.3. Once estimates of work complete and time expended on particular activities is available, deviations from the original duration estimate can be estimated. The calculations for making duration estimates are quite similar to those used in making cost estimates in Section 12.3.

For example, Figure 12-2 shows the originally scheduled project progress versus the actual progress on a project. This figure is constructed by summing up the percentage of each activity which is complete at different points in time; this summation can be weighted by the magnitude of effort associated with each activity. In Figure 12-2, the project was ahead of the original schedule for a period including point A, but is now late at point B by an amount equal to the horizontal distance between the planned progress and the actual progress observed to date.

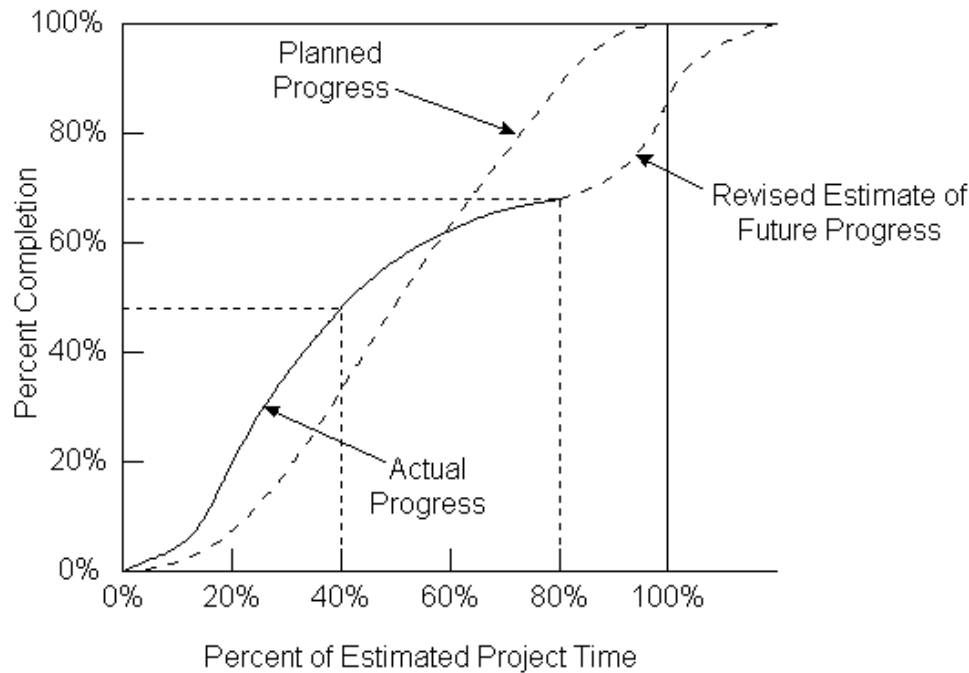

**Figure 12-2** Illustration of Planned versus Actual Progress over Time on a Project

Schedule adherence and the current status of a project can also be represented on geometric models of a facility. For example, an animation of the construction sequence can be shown on a computer screen, with different colors or other coding scheme indicating the type of activity underway on each component of the facility. Deviations from the planned schedule can also be portrayed by color coding. The result is a mechanism to both indicate work in progress and schedule adherence specific to individual components in the facility.

In evaluating schedule progress, it is important to bear in mind that some activities possess float or scheduling leeway, whereas delays in activities on the critical path will cause project delays. In particular, the delay in planned progress at time  $t$  may be soaked up in activities' float (thereby causing no overall delay in the project completion) or may cause a project delay. As a result of this ambiguity, it is preferable to update the project schedule to devise an accurate portrayal of the schedule adherence. After applying a scheduling algorithm, a new project schedule can be obtained. For cash flow planning purposes, a graph or report similar to that shown in Figure 12-3 can be constructed to compare actual expenditures to planned expenditures at any time. This process of re-scheduling to indicate the schedule adherence is only one of many instances in which schedule and budget updating may be appropriate, as discussed in the next section.

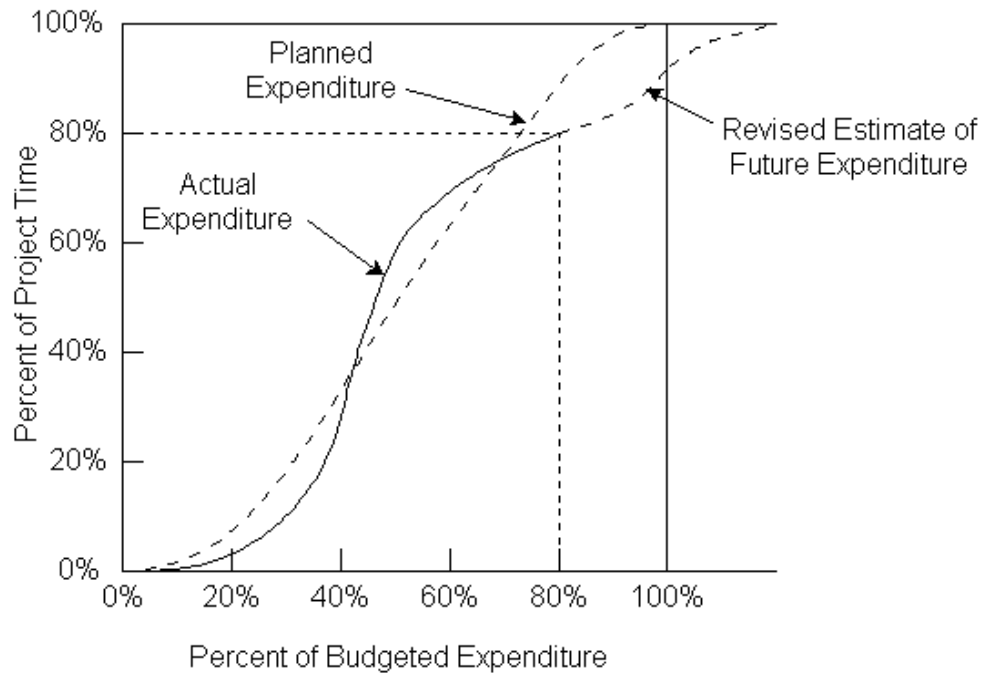

**Figure 12-3** Illustration of Planned versus Actual Expenditures on a Project

[Back to top](#)

## 12.7 Schedule and Budget Updates

Scheduling and project planning is an activity that continues throughout the lifetime of a project. As changes or discrepancies between the plan and the realization occur, the project schedule and cost estimates should be modified and new schedules devised. Too often, the schedule is devised once by a planner in the central office, and then revisions or modifications are done incompletely or only sporadically. The result is the lack of effective project monitoring and the possibility of eventual chaos on the project site.

On "fast track" projects, initial construction activities are begun even before the facility design is finalized. In this case, special attention must be placed on the coordinated scheduling of design and construction activities. Even in projects for which the design is finalized before construction begins, *change orders* representing changes in the "final" design are often issued to incorporate changes desired by the owner.

Periodic updating of future activity durations and budgets is especially important to avoid excessive optimism in projects experiencing problems. If one type of activity experiences delays on a project, then related activities are also likely to be delayed unless managerial changes are made. Construction projects normally involve numerous activities which are closely related due to the use of similar materials, equipment, workers or site characteristics. Expected cost changes should also be propagated throughout a project plan. In essence, duration and cost estimates for future activities should be revised in light of the actual experience on the job. Without this updating, project schedules slip more and more as time progresses. To perform this type of updating, project managers need access to original estimates and estimating assumptions.

Unfortunately, most project cost control and scheduling systems do not provide many aids for such updating. What is required is a means of identifying discrepancies, diagnosing the cause, forecasting the effect, and propagating this effect to all related activities. While these steps can be undertaken manually, computers aids to support interactive updating or even automatic updating would be helpful. [8]

Beyond the direct updating of activity durations and cost estimates, project managers should have mechanisms available for evaluating any type of schedule change. Updating activity duration estimations, changing scheduled start times, modifying the estimates of resources required for each activity, and even changing the project network logic (by inserting new activities or other changes) should all be easily accomplished. In effect, scheduling aids should be directly available to project managers. [9] Fortunately, local computers are commonly available on site for this purpose.

### Example 12-6: Schedule Updates in a Small Project

As an example of the type of changes that might be required, consider the nine activity project described in Section 10.3 and appearing in Figure 12-4. Also, suppose that the project is four days underway, with the current activity schedule and progress as shown in Figure 12-5. A few problems or changes that might be encountered include the following:

1. An underground waterline that was previously unknown was ruptured during the fifth day of the project. An extra day was required to replace the ruptured section, and another day will be required for clean-up. What is the impact on the project duration?
  - o To analyze this change with the critical path scheduling procedure, the manager has the options of (1) changing the expected duration of activity C, General Excavation, to the new expected duration of 10 days or (2) splitting activity C into two tasks (corresponding to the work done prior to the waterline break and that to be done after) and adding a new activity representing repair and clean-up from the waterline break. The second approach has the advantage that any delays to other activities (such as activities D and E) could also be indicated by precedence constraints.
  - o Assuming that no other activities are affected, the manager decides to increase the expected duration of activity C to 10 days. Since activity C is on the critical path, the project duration also increases by 2 days. Applying the critical path scheduling procedure would confirm this change and also give a new set of earliest and latest starting times for the various activities.
2. After 8 days on the project, the owner asks that a new drain be installed in addition to the sewer line scheduled for activity G. The project manager determines that a new activity could be added to install the drain in parallel with Activity G and requiring 2 days. What is the effect on the schedule?
  - o Inserting a new activity in the project network between nodes 3 and 4 violates the activity-on-branch convention that only one activity can be defined between any two nodes. Hence, a new node and a dummy activity must be inserted in addition to the drain installation activity. As a result, the nodes must be re-numbered and the critical path schedule developed again. Performing these operations reveals that no change in the project duration would occur and the new activity has a total float of 1 day.
  - o To avoid the labor associated with modifying the network and re-numbering nodes, suppose that the project manager simply re-defined activity G as installation of sewer and drain lines requiring 4 days. In this case, activity G would appear on the critical path and the project duration would increase. Adding an additional crew so that the two installations could proceed in parallel might reduce the duration of activity G back to 2 days and thereby avoid the increase in the project duration.
3. At day 12 of the project, the excavated trenches collapse during Activity E. An additional 5 days will be required for this activity. What is the effect on the project schedule? What changes should be made to insure meeting the completion deadline?
  - o Activity E has a total float of only 1 day. With the change in this activity's duration, it will lie on the critical path and the project duration will increase.
  - o Analysis of possible time savings in subsequent activities is now required, using the procedures described in Section 10.9.



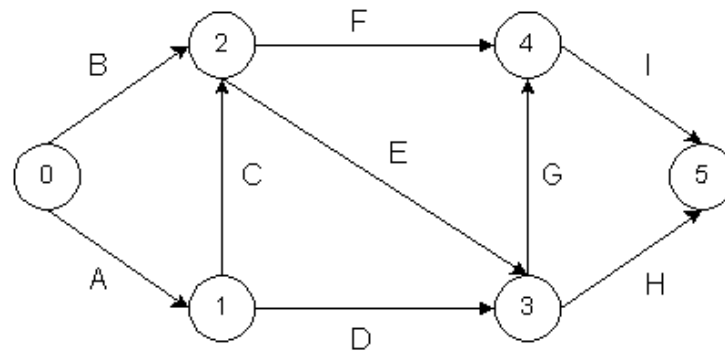

**Figure 12-4** A Nine Activity Example Project

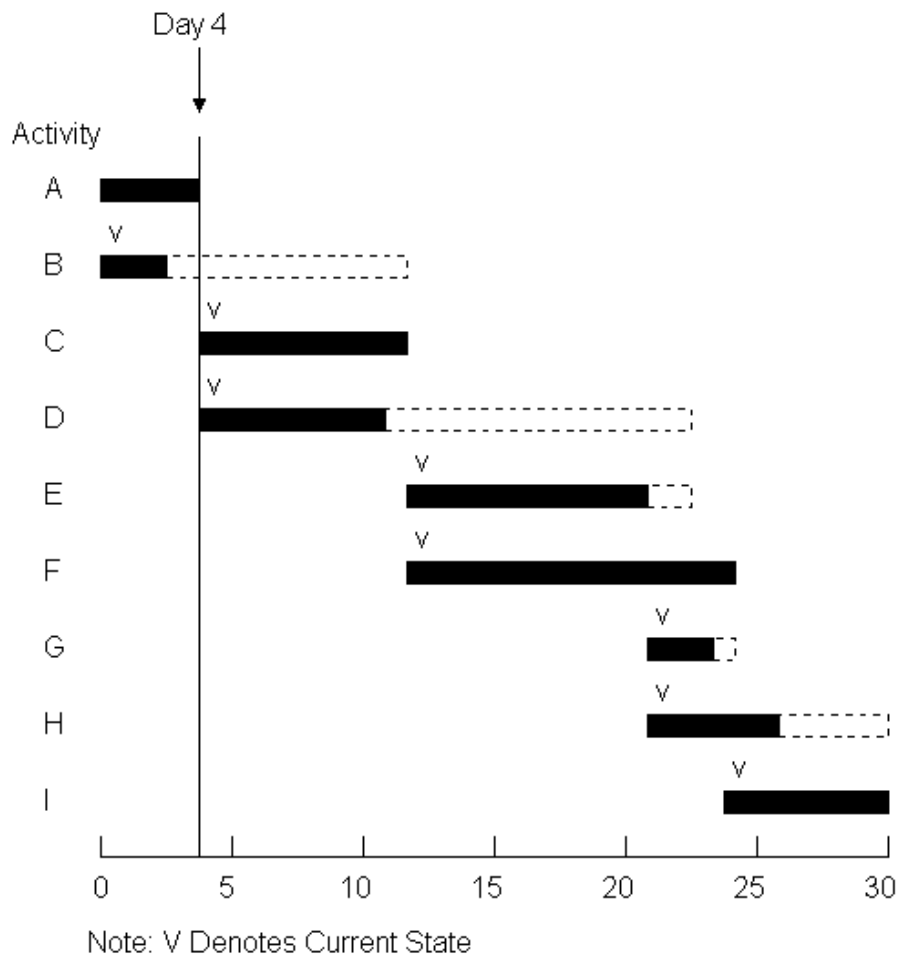

**Figure 12-5** Current Schedule for an Example Project Presented as a Bar Chart

As can be imagined, it is not at all uncommon to encounter changes during the course of a project that require modification of durations, changes in the network logic of precedence relationships, or additions and deletions of activities. Consequently, the scheduling process should be readily available

as the project is underway.

[Back to top](#)

## 12.8 Relating Cost and Schedule Information

The previous sections focused upon the identification of the budgetary and schedule status of projects. Actual projects involve a complex inter-relationship between time and cost. As projects proceed, delays influence costs and budgetary problems may in turn require adjustments to activity schedules. Trade-offs between time and costs were discussed in Section 10.9 in the context of project planning in which additional resources applied to a project activity might result in a shorter duration but higher costs. Unanticipated events might result in increases in both time and cost to complete an activity. For example, excavation problems may easily lead to much lower than anticipated productivity on activities requiring digging.

While project managers implicitly recognize the inter-play between time and cost on projects, it is rare to find effective project control systems which include both elements. Usually, project costs and schedules are recorded and reported by separate application programs. Project managers must then perform the tedious task of relating the two sets of information.

The difficulty of integrating schedule and cost information stems primarily from the level of detail required for effective integration. Usually, a single project activity will involve numerous cost account categories. For example, an activity for the preparation of a foundation would involve laborers, cement workers, concrete forms, concrete, reinforcement, transportation of materials and other resources. Even a more disaggregated activity definition such as erection of foundation forms would involve numerous resources such as forms, nails, carpenters, laborers, and material transportation. Again, different cost accounts would normally be used to record these various resources. Similarly, numerous activities might involve expenses associated with particular cost accounts. For example, a particular material such as standard piping might be used in numerous different schedule activities. To integrate cost and schedule information, the disaggregated charges for specific activities and specific cost accounts must be the basis of analysis.

A straightforward means of relating time and cost information is to define individual *work elements* representing the resources in a particular cost category associated with a particular project activity. Work elements would represent an element in a two-dimensional matrix of activities and cost accounts as illustrated in Figure 12-6. A numbering or identifying system for work elements would include both the relevant cost account and the associated activity. In some cases, it might also be desirable to identify work elements by the responsible organization or individual. In this case, a three dimensional representation of work elements is required, with the third dimension corresponding to responsible individuals. [10] More generally, modern computerized databases can accommodate a flexible structure of data representation to support aggregation with respect to numerous different perspectives; this type of system will be discussed in Chapter 14.

With this organization of information, a number of management reports or views could be generated. In particular, the costs associated with specific activities could be obtained as the sum of the work elements appearing in any row in Figure 12-6. These costs could be used to evaluate alternate technologies to accomplish particular activities or to derive the expected project cash flow over time as the schedule changes. From a management perspective, problems developing from particular activities could be rapidly identified since costs would be accumulated at such a disaggregated level. As a result, project control becomes at once more precise and detailed.

Project Activity Group	Cost Amount for Superstructure					
	204.1	204.2	204.3	204.4	204.5	204.6
First Floor	X	X		X		X
Second Floor		X		X		X
Third Floor		X	X	X		X
Fourth Floor		X	X			X
Fifth Floor		X	X		X	X

**Figure 12-6** Illustration of a Cost Account and Project Activity Matrix

Unfortunately, the development and maintenance of a work element database can represent a large data collection and organization effort. As noted earlier, four hundred separate cost accounts and four hundred activities would not be unusual for a construction project. The result would be up to  $400 \times 400 = 160,000$  separate work elements. Of course, not all activities involve each cost account. However, even a density of two percent (so that each activity would have eight cost accounts and each account would have eight associated activities on the average) would involve nearly thirteen thousand work elements. Initially preparing this database represents a considerable burden, but it is also the case that project bookkeepers must record project events within each of these various work elements. Implementations of the "work element" project control systems have typically pondered on the burden of data collection, storage and book-keeping.

Until data collection is better automated, the use of work elements to control activities in large projects is likely to be difficult to implement. However, certain segments of project activities can profit tremendously from this type of organization. In particular, material requirements can be tracked in this fashion. Materials involve only a subset of all cost accounts and project activities, so the burden of data collection and control is much smaller than for an entire system. Moreover, the benefits from integration of schedule and cost information are particularly noticeable in materials control since delivery schedules are directly affected and bulk order discounts might be identified. Consequently, materials control systems can reasonably encompass a "work element" accounting system.

In the absence of a work element accounting system, costs associated with particular activities are usually estimated by summing expenses in all cost accounts directly related to an activity plus a proportion of expenses in cost accounts used jointly by two or more activities. The basis of cost allocation would typically be the level of effort or resource required by the different activities. For example, costs associated with supervision might be allocated to different concreting activities on the basis of the amount of work (measured in cubic yards of concrete) in the different activities. With these allocations, cost estimates for particular work activities can be obtained.

[Back to top](#)

## 12.9 References

1. American Society of Civil Engineers, "Construction Cost Control," ASCE Manuals and Reports of Engineering Practice No. 65, Rev. Ed., 1985.
2. Coombs, W.E. and W.J. Palmer, *Construction Accounting and Financial Management*, McGraw-Hill, New York, 1977.
3. Halpin, D. W., *Financial and Cost Concepts for Construction Management*, John Wiley & Sons, New York, 1985.
4. Johnson, H. Thomas and Robert S. Kaplan, *Relevance Lost, The Rise and Fall of Management Accounting*, Harvard Business School Press, Boston, MA 1987.
5. Mueller, F.W. *Integrated Cost and Schedule Control for Construction Projects*, Van Nostrand Reinhold Company, New York, 1986.
6. Tersine, R.J., *Principles of Inventory and Materials Management*, North Holland, 1982.

[Back to top](#)

## 12.10 Problems

- Suppose that the expected expenditure of funds in a particular category was expected to behave in a piecewise linear fashion over the course of the project. In particular, the following points have been established from historical records for the percentage of completion versus the expected expenditure (as a percentage of the budget):

Percentage of Completion	Expected Expenditure
0%	0%
20%	10%
40%	25%
60%	55%
80%	90%
100%	100%

- Graph the relationship between percentage complete and expected expenditure.
  - Develop a formula or set of formulas for forecasting the ultimate expenditure on this activity given the percentage of completion. Assume that any over or under expenditure will continue to grow proportionately during the course of the project.
  - Using your formula, what is the expected expenditure as a percentage of the activity budget if:
    - 15% of funds have been expended and 15% of the activity is complete.
    - 30% of funds have been expended and 30% of the activity is complete.
    - 80% of funds have been expended and 80% of the activity is complete.
- Repeat Problem 1 parts (b) and (c) assuming that any over or under expenditure will not continue to grow during the course of the project.
  - Suppose that you have been asked to take over as project manager on a small project involving installation of 5,000 linear feet (LF) of metal ductwork in a building. The job was originally estimated to take ten weeks, and you are assuming your duties after three weeks on the project. The original estimate assumed that each linear foot of ductwork would cost \$10, representing \$6 in labor costs and \$4 in material cost. The expected production rate was 500 linear feet of ductwork per week. Appearing below is the data concerning this project available from your firm's job control information system:

Week	Weekly Unit Costs (\$/Lf)			Quantity Placed (Lf)		Total Cost	
	Labor	Materials	Total	Week	To Date	Week	To Date
1	12.00	4.00	16.00	250	250	4,000	4,000
2	8.57	4.00	12.57	350	600	4,400	8,400
3	6.67	4.00	10.67	450	1,050	4,800	13,200

- Based on an extrapolation using the average productivity and cost for all three weeks, forecast the completion time, cost and variance from original estimates.
  - Suppose that you assume that the productivity achieved in week 3 would continue for the remainder of the project. How would this affect your forecasts in (a)? Prepare new forecasts based on this assumption.
- What criticisms could you make of the job status report in the previous problem from the viewpoint of good project management?
  - Suppose that the following estimate was made for excavation of 120,000 cubic yards on a site:

Resource	Quantity	Cost
Machines	1,200 hours	\$60,000
Labor	6,000 hours	150,000
Trucks	2,400 hours	<u>75,000</u>
Total		\$285,000

After 95,000 cubic yards of excavation was completed, the following expenditures had been recorded:

Resource	Quantity	Cost
Machines	1,063 hours	\$47,835
Labor	7,138 hours	142,527
Trucks	1,500 hours	<u>46,875</u>
Total		\$237,237

- a. Calculate estimated and experienced productivity (cubic yards per hour) and unit cost (cost per cubic yard) for each resource.
  - b. Based on straight line extrapolation, do you see any problem with this activity? If so, can you suggest a reason for the problem based on your findings in (a)?
6. Suppose the following costs and units of work completed were recorded on an activity:

Month	Monthly Expenditure	Number of Work Units Completed
1	\$1,200	30
2	\$1,250	32
3	\$1,260	38
4	\$1,280	42
5	\$1,290	42
6	\$1,280	42

Answer the following questions:

- a. For each month, determine the cumulative cost, the cumulative work completed, the average cumulative cost per unit of work, and the monthly cost per unit of work.
  - b. For each month, prepare a forecast of the eventual cost-to-complete the activity based on the proportion of work completed.
  - c. For each month, prepare a forecast of the eventual cost-to-complete the activity based on the average productivity experienced on the activity.
  - d. For each month, prepare a forecast of the eventual cost-to-complete the activity based on the productivity experienced in the previous month.
  - e. Which forecasting method (b, c or d) is preferable for this activity? Why?
7. Repeat Problem 6 for the following expenditure pattern:

Month	Monthly Expenditure	Number of Work Units Completed
1	\$1,200	30
2	\$1,250	35
3	\$1,260	45
4	\$1,280	48

5	\$1,290	52
6	\$1,300	54

8. Why is it difficult to integrate scheduling and cost accounting information in project records?
9. Prepare a schedule progress report on planned versus actual expenditure on a project (similar to that in Figure 12-5) for the project described in Example 12-6.
10. Suppose that the following ten activities were agreed upon in a contract between an owner and an engineer.

Original Work Plan Information			
Activity	Duration (months)	Predecessors	Estimated Cost (\$ thousands)
A	2	---	7
B	5	---	9
C	5	B	8
D	2	C	4
E	3	B	1
F	8	---	7
G	4	E, F	6
H	4	E, F	5
I	11	B	10
J	2	E, F	7

Original Contract Information	
Total Direct Cost	\$64
Overhead	64
Total Direct and Overhead	128
Profit	12.8
Total Contract Amount	\$140.8

First Year Cash Flow	
Expenditures	\$56,000
Receipts	\$60,800

The markup on the activities' costs included 100% overhead and a profit of 10% on all costs (including overhead). This job was suspended for one year after completion of the first four activities, and the owner paid a total of \$60,800 to the engineer. Now the owner wishes to re-commence the job. However, general inflation has increased costs by ten percent in the intervening year. The engineer's discount rate is 15 percent per year (in current year dollars). For simplicity, you may assume that all cash transactions occur at the end of the year in making discounting calculations in answering the following questions:

- a. How long will be remaining six activities require?
  - b. Suppose that the owner agrees to make a lump sum payment of the remaining original contract at the completion of the project. Would the engineer still make a profit on the job? If so, how much?
  - c. Given that the engineer would receive a lump sum payment at the end of the project, what amount should he request in order to earn his desired ten percent profit on all costs?
  - d. What is the net future value of the entire project at the end, assuming that the lump sum payment you calculated in (c) is obtained?
11. Based on your knowledge of coding systems such as MASTERFORMAT and estimating techniques, outline the procedures that might be implemented to accomplish:
    - a. automated updating of duration and cost estimates of activities in light of experience on

earlier, similar activities.

b. interactive computer based aids to help a project manager to accomplish the same task.

[Back to top](#)

## 12.11 Footnotes

1. Cited in Zoll, Peter F., "Database Structures for Project Management," *Proceedings of the Seventh Conference on Electronic Computation*, ASCE, 1979. [Back](#)
2. Thomas Gibb reports a median number of 400 cost accounts for a two-million dollar projects in a sample of 30 contractors in 1975. See T.W. Gibb, Jr., "Building Construction in Southeastern United States," School of Civil Engineering, Georgia Institute of Technology, 1975, reported in D.W. Halpin, *Financial and Cost Concepts for Construction Management*, John Wiley and Sons, 1985. [Back](#)
3. This illustrative set of accounts was adapted from an ASCE Manual of Practice: *Construction Cost Control*, Task Committee on Revision of Construction Cost Control Manual, ASCE, New York, 1985. [Back](#)
4. For a fuller exposition of this point, see W.H. Lucas and T.L. Morrison, "Management Accounting for Construction Contracts," *Management Accounting*, 1981, pp. 59-65. [Back](#)
5. For a description of these methods and examples as used by a sample of construction companies, see L.S. Riggs, *Cost and Schedule Control in Industrial Construction*, Report to The Construction Industry Institute, Dec. 1986. [Back](#)
6. As reported in the *Wall Street Journal*, Feb. 19, 1986, pg. A1, c. 4. [Back](#)
7. H.T. Johnson and R.S. Kaplan, *Relevance Lost, The Rise and Fall of Management Accounting*, Harvard Business School Press, pg. 1, 1987. [Back](#)
8. One experimental program directed at this problem is a knowledge based expert system described in R.E. Levitt and J.C. Kunz, "Using Knowledge of Construction and Project Management for Automated Schedule Updating," *Project Management Journal*, Vol. 16, 1985, pp. 57-76. [Back](#)
9. For an example of a prototype interactive project management environment that includes graphical displays and scheduling algorithms, see R. Kromer, "Interactive Activity Network Analysis Using a Personal Computer," Unpublished MS Thesis, Department of Civil Engineering, Carnegie-Mellon University, Pittsburgh, PA, 1984. [Back](#)
10. A three dimensional work element definition was proposed by J.M. Neil, "A System for Integrated Project Management," *Proceedings of the Conference on Current Practice in Cost Estimating and Cost Control*, ASCE, Austin, Texas, 138-146, April 1983. [Back](#)

[Previous Chapter](#) | [Table of Contents](#) | [Next Chapter](#)

<a href="#">Go Up to Table of Contents</a>	
<a href="#">Go To Chapter 12 (Cost Control, Monitoring and Accounting)</a>	<a href="#">Go To Chapter 14 (Organization and Use of Project Information)</a>
<a href="#">Quality Control and Safety During Construction</a>	
<a href="#">Quality and Safety Concerns in Construction</a>	
<a href="#">Organizing for Quality and Safety Work and Material Specifications</a>	
<a href="#">Total Quality Control</a>	
<a href="#">Quality Control by Statistical Methods</a>	
<a href="#">Statistical Quality Control with Sampling by Attributes</a>	
<a href="#">Statistical Quality Control with Sampling by Variables</a>	
<a href="#">Safety</a>	
<a href="#">References</a>	
<a href="#">Problems</a>	
<a href="#">Footnotes</a>	

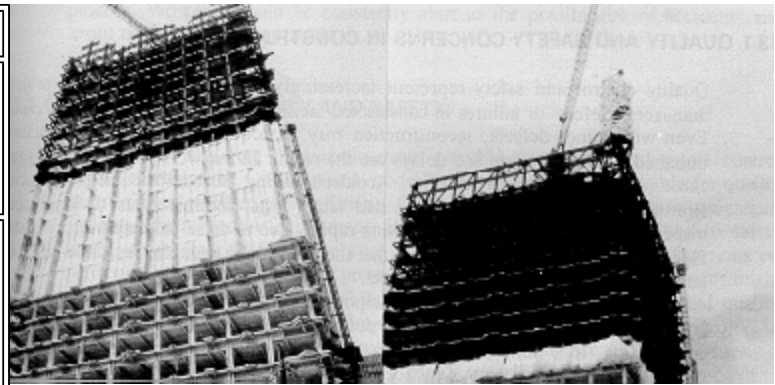

[http://pmbook.ce.cmu.edu/13\\_Quality\\_Control\\_and\\_Safety\\_During\\_Construction.html](http://pmbook.ce.cmu.edu/13_Quality_Control_and_Safety_During_Construction.html)

# 13. Quality Control and Safety During Construction

## 13.1 Quality and Safety Concerns in Construction

Quality control and safety represent increasingly important concerns for project managers. Defects or failures in constructed facilities can result in very large costs. Even with minor defects, re-construction may be required and facility operations impaired. Increased costs and delays are the result. In the worst case, failures may cause personal injuries or fatalities. Accidents during the construction process can similarly result in personal injuries and large costs. Indirect costs of insurance, inspection and regulation are increasing rapidly due to these increased direct costs. Good project managers try to ensure that the job is done right the first time and that no major accidents occur on the project.

As with cost control, the most important decisions regarding the quality of a completed facility are made during the design and planning stages rather than during construction. It is during these preliminary stages that component configurations, material specifications and functional performance are decided. Quality control during construction consists largely of insuring *conformance* to these original design and planning decisions.

While conformance to existing design decisions is the primary focus of quality control, there are exceptions to this rule. First, unforeseen circumstances, incorrect design decisions or changes desired by an owner in the facility function may require re-evaluation of design decisions during the course of construction. While these changes may be motivated by the concern for quality, they represent occasions for re-design with all the attendant objectives and constraints. As a second case, some designs rely upon informed and appropriate decision making during the construction process itself. For example, some



tunneling methods make decisions about the amount of shoring required at different locations based upon observation of soil conditions during the tunneling process. Since such decisions are based on better information concerning actual site conditions, the facility design may be more cost effective as a result. Any special case of re-design during construction requires the various considerations discussed in Chapter 3.

With the attention to conformance as the measure of quality during the construction process, the specification of quality requirements in the design and contract documentation becomes extremely important. Quality requirements should be clear and verifiable, so that all parties in the project can understand the requirements for conformance. Much of the discussion in this chapter relates to the development and the implications of different quality requirements for construction as well as the issues associated with insuring conformance.

Safety during the construction project is also influenced in large part by decisions made during the planning and design process. Some designs or construction plans are inherently difficult and dangerous to implement, whereas other, comparable plans may considerably reduce the possibility of accidents. For example, clear separation of traffic from construction zones during roadway rehabilitation can greatly reduce the possibility of accidental collisions. Beyond these design decisions, safety largely depends upon education, vigilance and cooperation during the construction process. Workers should be constantly alert to the possibilities of accidents and avoid taken unnecessary risks.

[Back to top](#)

## 13.2 Organizing for Quality and Safety

A variety of different organizations are possible for quality and safety control during construction. One common model is to have a group responsible for quality assurance and another group primarily responsible for safety within an organization. In large organizations, departments dedicated to quality assurance and to safety might assign specific individuals to assume responsibility for these functions on particular projects. For smaller projects, the project manager or an assistant might assume these and other responsibilities. In either case, insuring safe and quality construction is a concern of the project manager in overall charge of the project in addition to the concerns of personnel, cost, time and other management issues.

Inspectors and quality assurance personnel will be involved in a project to represent a variety of different organizations. Each of the parties directly concerned with the project may have their own quality and safety inspectors, including the owner, the engineer/architect, and the various constructor firms. These inspectors may be contractors from specialized quality assurance organizations. In addition to on-site inspections, samples of materials will commonly be tested by specialized laboratories to insure compliance. Inspectors to insure compliance with regulatory requirements will also be involved. Common examples are inspectors for the local government's building department, for environmental agencies, and for occupational health and safety agencies.

The US Occupational Safety and Health Administration (OSHA) routinely conducts site visits of work places in conjunction with approved state inspection agencies. OSHA inspectors are required by law to issue citations for all standard violations observed. Safety standards prescribe a variety of mechanical safeguards and procedures; for example, ladder safety is covered by over 140 regulations. In cases of extreme non-compliance with standards, OSHA inspectors can stop work on a project. However, only a small fraction of construction sites are visited by OSHA inspectors and most construction site accidents are not caused by violations of existing standards. As a result, safety is largely the responsibility of the

managers on site rather than that of public inspectors.

While the multitude of participants involved in the construction process require the services of inspectors, it cannot be emphasized too strongly that inspectors are only a formal check on quality control. Quality control should be a primary objective for all the members of a project team. Managers should take responsibility for maintaining and improving quality control. Employee participation in quality control should be sought and rewarded, including the introduction of new ideas. Most important of all, quality improvement can serve as a catalyst for improved productivity. By suggesting new work methods, by avoiding rework, and by avoiding long term problems, good quality control can pay for itself. Owners should promote good quality control and seek out contractors who maintain such standards.

In addition to the various organizational bodies involved in quality control, issues of quality control arise in virtually all the functional areas of construction activities. For example, insuring accurate and useful information is an important part of maintaining quality performance. Other aspects of quality control include document control (including changes during the construction process), procurement, field inspection and testing, and final checkout of the facility.

[Back to top](#)

### 13.3 Work and Material Specifications

Specifications of work quality are an important feature of facility designs. Specifications of required quality and components represent part of the necessary documentation to describe a facility. Typically, this documentation includes any special provisions of the facility design as well as references to generally accepted specifications to be used during construction.

General specifications of work quality are available in numerous fields and are issued in publications of organizations such as the American Society for Testing and Materials (ASTM), the American National Standards Institute (ANSI), or the Construction Specifications Institute (CSI). Distinct specifications are formalized for particular types of construction activities, such as welding standards issued by the American Welding Society, or for particular facility types, such as the *Standard Specifications for Highway Bridges* issued by the American Association of State Highway and Transportation Officials. These general specifications must be modified to reflect local conditions, policies, available materials, local regulations and other special circumstances.

Construction specifications normally consist of a series of instructions or prohibitions for specific operations. For example, the following passage illustrates a typical specification, in this case for excavation for structures:

Conform to elevations and dimensions shown on plan within a tolerance of plus or minus 0.10 foot, and extending a sufficient distance from footings and foundations to permit placing and removal of concrete formwork, installation of services, other construction, and for inspection. In excavating for footings and foundations, take care not to disturb bottom of excavation. Excavate by hand to final grade just before concrete reinforcement is placed. Trim bottoms to required lines and grades to leave solid base to receive concrete.

This set of specifications requires judgment in application since some items are not precisely specified. For example, excavation must extend a "sufficient" distance to permit inspection and other activities. Obviously, the term "sufficient" in this case may be subject to varying interpretations. In contrast, a

specification that tolerances are within plus or minus a tenth of a foot is subject to direct measurement. However, specific requirements of the facility or characteristics of the site may make the standard tolerance of a tenth of a foot inappropriate. Writing specifications typically requires a trade-off between assuming reasonable behavior on the part of all the parties concerned in interpreting words such as "sufficient" versus the effort and possible inaccuracy in pre-specifying all operations.

In recent years, *performance specifications* have been developed for many construction operations. Rather than specifying the required construction *process*, these specifications refer to the required performance or quality of the finished facility. The exact method by which this performance is obtained is left to the construction contractor. For example, traditional specifications for asphalt pavement specified the composition of the asphalt material, the asphalt temperature during paving, and compacting procedures. In contrast, a performance specification for asphalt would detail the desired performance of the pavement with respect to impermeability, strength, etc. How the desired performance level was attained would be up to the paving contractor. In some cases, the payment for asphalt paving might increase with better quality of asphalt beyond some minimum level of performance.

### Example 13-1: Concrete Pavement Strength

Concrete pavements of superior strength result in cost savings by delaying the time at which repairs or re-construction is required. In contrast, concrete of lower quality will necessitate more frequent overlays or other repair procedures. Contract provisions with adjustments to the amount of a contractor's compensation based on pavement quality have become increasingly common in recognition of the cost savings associated with higher quality construction. Even if a pavement does not meet the "ultimate" design standard, it is still worth using the lower quality pavement and re-surfacing later rather than completely rejecting the pavement. Based on these life cycle cost considerations, a typical pay schedule might be: [\[1\]](#)

Load Ratio	Pay Factor
<0.50	Reject
0.50-0.69	0.90
0.70-0.89	0.95
0.90-1.09	1.00
1.10-1.29	1.05
1.30-1.49	1.10
>1.50	1.12

In this table, the Load Ratio is the ratio of the actual pavement strength to the desired design strength and the Pay Factor is a fraction by which the total pavement contract amount is multiplied to obtain the appropriate compensation to the contractor. For example, if a contractor achieves concrete strength twenty percent greater than the design specification, then the load ratio is 1.20 and the appropriate pay factor is 1.05, so the contractor receives a five percent bonus. Load factors are computed after tests on the concrete actually used in a pavement. Note that a 90% pay factor exists in this case with even pavement quality only 50% of that originally desired. This high pay factor even with weak concrete strength might exist since much of the cost of pavements are incurred in preparing the pavement foundation. Concrete strengths of less than 50% are cause for complete rejection in this case, however.

[Back to top](#)

## 13.4 Total Quality Control

Quality control in construction typically involves insuring compliance with minimum standards of material and workmanship in order to insure the performance of the facility according to the design. These minimum standards are contained in the specifications described in the previous section. For the purpose of insuring compliance, random samples and statistical methods are commonly used as the basis for accepting or rejecting work completed and batches of materials. Rejection of a batch is based on non-conformance or violation of the relevant design specifications. Procedures for this quality control practice are described in the following sections.

An implicit assumption in these traditional quality control practices is the notion of an *acceptable quality level* which is a allowable fraction of defective items. Materials obtained from suppliers or work performed by an organization is inspected and passed as acceptable if the estimated defective percentage is within the acceptable quality level. Problems with materials or goods are corrected after delivery of the product.

In contrast to this traditional approach of quality control is the goal of *total quality control*. In this system, no defective items are allowed anywhere in the construction process. While the zero defects goal can never be permanently obtained, it provides a goal so that an organization is never satisfied with its quality control program even if defects are reduced by substantial amounts year after year. This concept and approach to quality control was first developed in manufacturing firms in Japan and Europe, but has since spread to many construction companies. The best known formal certification for quality improvement is the International Organization for Standardization's ISO 9000 standard. ISO 9000 emphasizes good documentation, quality goals and a series of cycles of planning, implementation and review.

Total quality control is a commitment to quality expressed in all parts of an organization and typically involves many elements. Design reviews to insure safe and effective construction procedures are a major element. Other elements include extensive training for personnel, shifting the responsibility for detecting defects from quality control inspectors to workers, and continually maintaining equipment. Worker involvement in improved quality control is often formalized in *quality circles* in which groups of workers meet regularly to make suggestions for quality improvement. Material suppliers are also required to insure zero defects in delivered goods. Initially, all materials from a supplier are inspected and batches of goods with any defective items are returned. Suppliers with good records can be certified and not subject to complete inspection subsequently.

The traditional microeconomic view of quality control is that there is an "optimum" proportion of defective items. Trying to achieve greater quality than this optimum would substantially increase costs of inspection and reduce worker productivity. However, many companies have found that commitment to total quality control has substantial economic benefits that had been unappreciated in traditional approaches. Expenses associated with inventory, rework, scrap and warranties were reduced. Worker enthusiasm and commitment improved. Customers often appreciated higher quality work and would pay a premium for good quality. As a result, improved quality control became a competitive advantage.

Of course, total quality control is difficult to apply, particular in construction. The unique nature of each facility, the variability in the workforce, the multitude of subcontractors and the cost of making necessary investments in education and procedures make programs of total quality control in construction difficult. Nevertheless, a commitment to improved quality even without endorsing the goal

of zero defects can pay real dividends to organizations.

### Example 13-2: Experience with Quality Circles

Quality circles represent a group of five to fifteen workers who meet on a frequent basis to identify, discuss and solve productivity and quality problems. A circle leader acts as liaison between the workers in the group and upper levels of management. Appearing below are some examples of reported quality circle accomplishments in construction: [\[2\]](#)

1. On a highway project under construction by Taisei Corporation, it was found that the loss rate of ready-mixed concrete was too high. A quality circle composed of cement masons found out that the most important reason for this was due to an inaccurate checking method. By applying the circle's recommendations, the loss rate was reduced by 11.4%.
2. In a building project by Shimizu Construction Company, many cases of faulty reinforced concrete work were reported. The iron workers quality circle examined their work thoroughly and soon the faulty workmanship disappeared. A 10% increase in productivity was also achieved.

[Back to top](#)

## 13.5 Quality Control by Statistical Methods

An ideal quality control program might test all materials and work on a particular facility. For example, non-destructive techniques such as x-ray inspection of welds can be used throughout a facility. An on-site inspector can witness the appropriateness and adequacy of construction methods at all times. Even better, individual craftsmen can perform continuing inspection of materials and their own work. Exhaustive or 100% testing of all materials and work by inspectors can be exceedingly expensive, however. In many instances, testing requires the destruction of a material sample, so exhaustive testing is not even possible. As a result, small samples are used to establish the basis of accepting or rejecting a particular work item or shipment of materials. Statistical methods are used to interpret the results of test on a small sample to reach a conclusion concerning the acceptability of an entire *lot* or batch of materials or work products.

The use of statistics is essential in interpreting the results of testing on a small sample. Without adequate interpretation, small sample testing results can be quite misleading. As an example, suppose that there are ten defective pieces of material in a lot of one hundred. In taking a sample of five pieces, the inspector might not find *any* defective pieces or might have *all* sample pieces defective. Drawing a direct inference that none or all pieces in the population are defective on the basis of these samples would be incorrect. Due to this random nature of the sample selection process, testing results can vary substantially. It is only with statistical methods that issues such as the chance of different levels of defective items in the full lot can be fully analyzed from a small sample test.

There are two types of statistical sampling which are commonly used for the purpose of quality control in batches of work or materials:

1. The acceptance or rejection of a lot is based on the number of defective (bad) or nondefective (good) items in the sample. This is referred to as *sampling by attributes*.
2. Instead of using defective and nondefective classifications for an item, a quantitative quality measure or the value of a measured variable is used as a quality indicator. This testing procedure

is referred to as *sampling by variables*.

Whatever sampling plan is used in testing, it is always assumed that the samples are representative of the entire population under consideration. Samples are expected to be chosen randomly so that each member of the population is equally likely to be chosen. Convenient sampling plans such as sampling every twentieth piece, choosing a sample every two hours, or picking the top piece on a delivery truck may be adequate to insure a random sample if pieces are randomly mixed in a stack or in use. However, some convenient sampling plans can be inappropriate. For example, checking only easily accessible joints in a building component is inappropriate since joints that are hard to reach may be more likely to have erection or fabrication problems.

Another assumption implicit in statistical quality control procedures is that the quality of materials or work is expected to vary from one piece to another. This is certainly true in the field of construction. While a designer may assume that all concrete is exactly the same in a building, the variations in material properties, manufacturing, handling, pouring, and temperature during setting insure that concrete is actually heterogeneous in quality. Reducing such variations to a minimum is one aspect of quality construction. Insuring that the materials actually placed achieve some minimum quality level with respect to average properties or fraction of defectives is the task of quality control.

[Back to top](#)

## 13.6 Statistical Quality Control with Sampling by Attributes

Sampling by attributes is a widely applied quality control method. The procedure is intended to determine whether or not a particular group of materials or work products is acceptable. In the literature of statistical quality control, a group of materials or work items to be tested is called a *lot* or *batch*. An assumption in the procedure is that each item in a batch can be tested and classified as either acceptable or deficient based upon mutually acceptable testing procedures and acceptance criteria. Each lot is tested to determine if it satisfies a minimum acceptable quality level (AQL) expressed as the maximum percentage of defective items in a lot or process.

In its basic form, sampling by attributes is applied by testing a pre-defined number of sample items from a lot. If the number of defective items is greater than a trigger level, then the lot is rejected as being likely to be of unacceptable quality. Otherwise, the lot is accepted. Developing this type of *sampling plan* requires consideration of probability, statistics and acceptable risk levels on the part of the supplier and consumer of the lot. Refinements to this basic application procedure are also possible. For example, if the number of defectives is greater than some pre-defined number, then additional sampling may be started rather than immediate rejection of the lot. In many cases, the trigger level is a single defective item in the sample. In the remainder of this section, the mathematical basis for interpreting this type of sampling plan is developed.

More formally, a lot is defined as acceptable if it contains a fraction  $p_1$  or less defective items. Similarly, a lot is defined as unacceptable if it contains a fraction  $p_2$  or more defective units. Generally, the acceptance fraction is less than or equal to the rejection fraction,  $p_1 \leq p_2$ , and the two fractions are often equal so that there is no ambiguous range of lot acceptability between  $p_1$  and  $p_2$ . Given a sample size and a trigger level for lot rejection or acceptance, we would like to determine the probabilities that acceptable lots might be incorrectly rejected (termed *producer's risk*) or that deficient lots might be incorrectly accepted (termed *consumer's risk*).

Consider a lot of finite number  $N$ , in which  $m$  items are defective (bad) and the remaining  $(N-m)$  items are non-defective (good). If a random sample of  $n$  items is taken from this lot, then we can determine the probability of having different numbers of defective items in the sample. With a pre-defined acceptable number of defective items, we can then develop the probability of accepting a lot as a function of the sample size, the allowable number of defective items, and the actual fraction of defective items. This derivation appears below.

The number of different samples of size  $n$  that can be selected from a finite population  $N$  is termed a mathematical *combination* and is computed as:

$$(13.1) \quad \binom{N}{n} = \frac{N(N-1)\dots(N-n+1)}{n!} = \frac{N!}{n!(N-n)!}$$

where a factorial,  $n!$  is  $n*(n-1)*(n-2)\dots(1)$  and zero factorial ( $0!$ ) is one by convention. The number of possible samples with exactly  $x$  defectives is the combination associated with obtaining  $x$  defectives from  $m$  possible defective items and  $n-x$  good items from  $N-m$  good items:

$$(13.2) \quad \binom{m}{x} \binom{N-m}{n-x} = \frac{m!}{x!(m-x)!} \times \frac{(N-m)!}{(n-x)!(N-m-n+x)!}$$

Given these possible numbers of samples, the probability of having exactly  $x$  defective items in the sample is given by the ratio as the hypergeometric series:

$$(13.3) \quad P(X = x) = \frac{\binom{m}{x} \binom{N-m}{n-x}}{\binom{N}{n}}$$

With this function, we can calculate the probability of obtaining different numbers of defectives in a sample of a given size.

Suppose that the actual fraction of defectives in the lot is  $p$  and the actual fraction of nondefectives is  $q$ , then  $p$  plus  $q$  is one, resulting in  $m = Np$ , and  $N - m = Nq$ . Then, a function  $g(p)$  representing the probability of having  $r$  or less defective items in a sample of size  $n$  is obtained by substituting  $m$  and  $N$  into Eq. (13.3) and summing over the acceptable defective number of items:

$$(13.4) \quad g(p) = \sum_{x=0}^r P(X=x) = \sum_{x=0}^r \frac{\binom{Np}{x} \binom{Nq}{n-x}}{\binom{N}{n}}$$

If the number of items in the lot,  $N$ , is large in comparison with the sample size  $n$ , then the function  $g(p)$  can be approximated by the binomial distribution:

$$(13.5) \quad g(p) = \sum_{x=0}^r \binom{n}{x} p^x q^{n-x}$$

or

$$(13.6) \quad g(p) = 1 - \sum_{x=r+1}^n \binom{n}{x} p^x q^{n-x}$$

The function  $g(p)$  indicates the probability of accepting a lot, given the sample size  $n$  and the number of allowable defective items in the sample  $r$ . The function  $g(p)$  can be represented graphically for each combination of sample size  $n$  and number of allowable defective items  $r$ , as shown in Figure 13-1. Each curve is referred to as the operating characteristic curve (OC curve) in this graph. For the special case of a single sample ( $n=1$ ), the function  $g(p)$  can be simplified:

$$(13.7) \quad g(p) = \binom{1}{0} p^0 q^1 = q$$

so that the probability of accepting a lot is equal to the fraction of acceptable items in the lot. For example, there is a probability of 0.5 that the lot may be accepted from a single sample test even if fifty percent of the lot is defective.



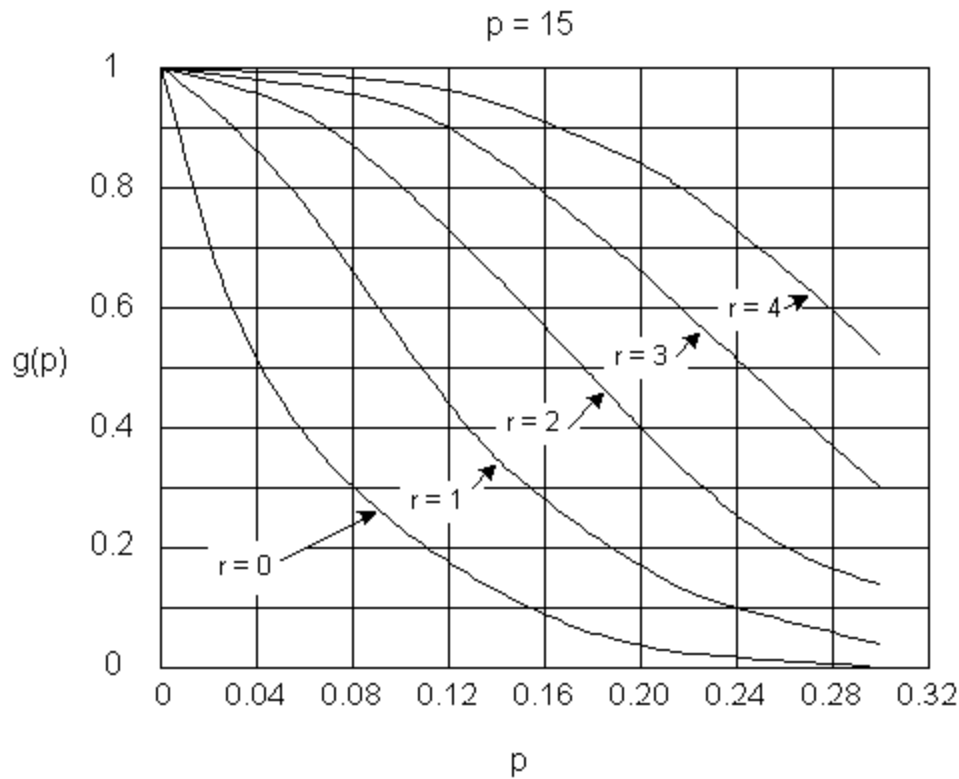

**Figure 13-1** Example Operating Characteristic Curves Indicating Probability of Lot Acceptance

For any combination of  $n$  and  $r$ , we can read off the value of  $g(p)$  for a given  $p$  from the corresponding OC curve. For example,  $n = 15$  is specified in Figure 13-1. Then, for various values of  $r$ , we find:

$r=0$	$p=24\%$	$g(p) \approx 2\%$
$r=0$	$p=4\%$	$g(p) \approx 54\%$
$r=1$	$p=24\%$	$g(p) \approx 10\%$
$r=1$	$p=4\%$	$g(p) \approx 88\%$

The producer's and consumer's risk can be related to various points on an operating characteristic curve. Producer's risk is the chance that otherwise *acceptable* lots fail the sampling plan (ie. have more than the allowable number of defective items in the sample) solely due to random fluctuations in the selection of the sample. In contrast, consumer's risk is the chance that an unacceptable lot is acceptable (ie. has less than the allowable number of defective items in the sample) due to a better than average quality in the sample. For example, suppose that a sample size of 15 is chosen with a trigger level for rejection of one item. With a four percent acceptable level and a greater than four percent defective fraction, the consumer's risk is at most eighty-eight percent. In contrast, with a four percent acceptable level and a four percent defective fraction, the producer's risk is at most  $1 - 0.88 = 0.12$  or twelve percent.

In specifying the sampling plan implicit in the operating characteristic curve, the supplier and consumer of materials or work must agree on the levels of risk acceptable to themselves. If the lot is of acceptable quality, the supplier would like to minimize the chance or risk that a lot is rejected solely on the basis of a lower than average quality sample. Similarly, the consumer would like to minimize the risk of

accepting under the sampling plan a deficient lot. In addition, both parties presumably would like to minimize the costs and delays associated with testing. Devising an acceptable sampling plan requires trade off the objectives of risk minimization among the parties involved and the cost of testing.

### Example 13-3: Acceptance probability calculation

Suppose that the sample size is five ( $n=5$ ) from a lot of one hundred items ( $N=100$ ). The lot of materials is to be rejected if any of the five samples is defective ( $r = 0$ ). In this case, the probability of acceptance as a function of the actual number of defective items can be computed by noting that for  $r = 0$ , only one term ( $x = 0$ ) need be considered in Eq. (13.4). Thus, for  $N = 100$  and  $n = 5$ :

$$g(p) = \frac{\binom{100p}{0} \binom{100q}{5}}{\binom{100}{5}}$$

For a two percent defective fraction ( $p = 0.02$ ), the resulting acceptance value is:

$$g(p) = \frac{\binom{2}{0} \binom{98}{5}}{\binom{100}{5}} = \frac{\frac{98!}{93! 5!}}{\frac{100!}{95! 5!}} = \frac{98! 95!}{93! 100!} = 0.9020$$

Using the binomial approximation in Eq. (13.5), the comparable calculation would be:

$$g(p) \approx \binom{5}{0} p^0 q^5 = q^5 = (0.98)^5 = 0.9039$$

which is a difference of 0.0019, or 0.21 percent from the actual value of 0.9020 found above.

If the acceptable defective proportion was two percent (so  $p_1 = p_2 = 0.02$ ), then the chance of an incorrect rejection (or producer's risk) is  $1 - g(0.02) = 1 - 0.9 = 0.1$  or ten percent. Note that a prudent producer should insure better than minimum quality products to reduce the probability or chance of rejection under this sampling plan. If the actual proportion of defectives was one percent, then the producer's risk would be only five percent with this sampling plan.

### Example 13-4: Designing a Sampling Plan

Suppose that an owner (or product "consumer" in the terminology of quality control) wishes to have zero defective items in a facility with 5,000 items of a particular kind. What would be the different amounts of consumer's risk for different sampling plans?

With an acceptable quality level of no defective items (so  $p_1 = 0$ ), the allowable defective items in the sample is zero (so  $r = 0$ ) in the sampling plan. Using the binomial approximation, the probability of accepting the 5,000 items as a function of the fraction of actual defective items and the sample size is:

$$g(p) = (1 - p)^n$$

To insure a ninety percent chance of rejecting a lot with an actual percentage defective of one percent ( $p = 0.01$ ), the required sample size would be calculated as:

$$g(p) = 1 - 0.90 = 0.1 = (1 - 0.01)^n$$

Then,

$$n = \frac{\ln(0.1)}{\ln(0.99)} = \frac{-2.30}{-0.01} \approx 229$$

As can be seen, large sample sizes are required to insure relatively large probabilities of zero defective items.

[Back to top](#)

## 13.7 Statistical Quality Control with Sampling by Variables

As described in the previous section, sampling by attributes is based on a classification of items as *good* or *defective*. Many work and material attributes possess continuous properties, such as strength, density or length. With the sampling by attributes procedure, a particular level of a variable quantity must be defined as acceptable quality. More generally, two items classified as *good* might have quite different strengths or other attributes. Intuitively, it seems reasonable that some "credit" should be provided for exceptionally good items in a sample. Sampling by variables was developed for application to continuously measurable quantities of this type. The procedure uses measured values of an attribute in a sample to determine the overall acceptability of a batch or lot. Sampling by variables has the advantage of using more information from tests since it is based on actual measured values rather than a simple classification. As a result, acceptance sampling by variables can be more efficient than sampling by attributes in the sense that fewer samples are required to obtain a desired level of quality control.

In applying sampling by variables, an acceptable lot quality can be defined with respect to an upper limit U, a lower limit L, or both. With these boundary conditions, an acceptable quality level can be defined as a maximum allowable fraction of defective items, M. In Figure 13-2, the probability distribution of item attribute x is illustrated. With an upper limit U, the fraction of defective items is equal to the area

under the distribution function to the right of  $U$  (so that  $x \geq U$ ). This fraction of defective items would be compared to the allowable fraction  $M$  to determine the acceptability of a lot. With both a lower and an upper limit on acceptable quality, the fraction defective would be the fraction of items greater than the upper limit or less than the lower limit. Alternatively, the limits could be imposed upon the acceptable *average* level of the variable

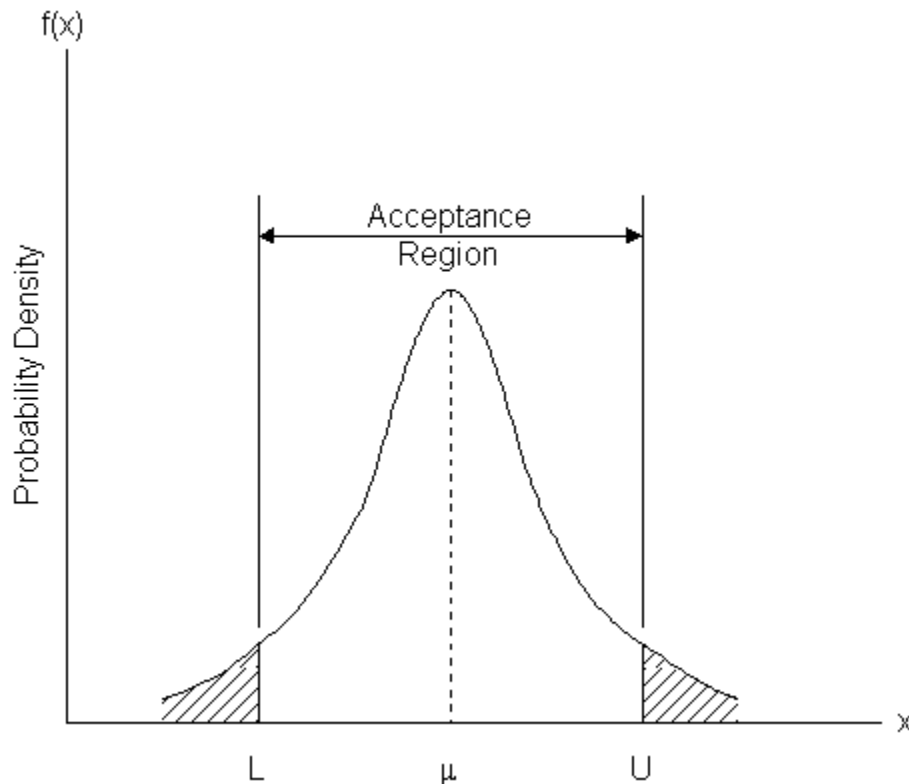

**Figure 13-2** Variable Probability Distributions and Acceptance Regions

In sampling by variables, the fraction of defective items is estimated by using measured values from a sample of items. As with sampling by attributes, the procedure assumes a random sample of a given size is obtained from a lot or batch. In the application of sampling by variables plans, the measured characteristic is virtually always assumed to be *normally distributed* as illustrated in Figure 13-2. The normal distribution is likely to be a reasonably good assumption for many measured characteristics such as material density or degree of soil compaction. The Central Limit Theorem provides a general support for the assumption: if the source of variations is a large number of small and independent random effects, then the resulting distribution of values will approximate the normal distribution. If the distribution of measured values is not likely to be approximately normal, then sampling by attributes should be adopted. Deviations from normal distributions may appear as *skewed* or non-symmetric distributions, or as distributions with fixed upper and lower limits.

The fraction of defective items in a sample or the chance that the population average has different values is estimated from two statistics obtained from the sample: the sample mean and standard deviation. Mathematically, let  $n$  be the number of items in the sample and  $x_i$ ,  $i = 1, 2, 3, \dots, n$ , be the measured values

of the variable characteristic  $x$ . Then an estimate of the overall population mean  $\mu$  is the sample mean  $\bar{x}$  :

$$(13.8) \quad \mu \approx \bar{x} = \frac{1}{n} \sum_{i=1}^n x_i$$

An estimate of the population standard deviation is  $s$ , the square root of the sample variance statistic:

$$(13.9) \quad \sigma^2 \approx s^2 = \frac{1}{n-1} \sum_{i=1}^n (x_i - \bar{x})^2 = \frac{1}{n-1} \left( \sum_{i=1}^n x_i^2 - n\bar{x}^2 \right)$$

Based on these two estimated parameters and the desired limits, the various fractions of interest for the population can be calculated.

The probability that the average value of a population is greater than a particular lower limit is calculated from the test statistic:

$$(13.10) \quad t_L = \frac{\bar{x} - L}{s/\sqrt{n}} = \frac{(\bar{x} - L)\sqrt{n}}{s}$$

which is t-distributed with  $n-1$  degrees of freedom. If the population standard deviation is known in advance, then this known value is substituted for the estimate  $s$  and the resulting test statistic would be normally distributed. The t distribution is similar in appearance to a standard normal distribution, although the spread or variability in the function *decreases* as the degrees of freedom parameter *increases*. As the number of degrees of freedom becomes very large, the t-distribution coincides with the normal distribution.

With an upper limit, the calculations are similar, and the probability that the average value of a population is less than a particular upper limit can be calculated from the test statistic:

$$(13.11) \quad t_U = \frac{U - \bar{x}}{s/\sqrt{n}} = \frac{(U - \bar{x})\sqrt{n}}{s}$$

With both upper and lower limits, the sum of the probabilities of being above the upper limit or below the lower limit can be calculated.

The calculations to estimate the fraction of items above an upper limit or below a lower limit are very

similar to those for the population average. The only difference is that the square root of the number of samples does not appear in the test statistic formulas:

$$(13.12) \quad t_{AL} = \frac{\bar{x} - L}{s}$$

and

$$(13.13) \quad t_{AU} = \frac{U - \bar{x}}{s}$$

where  $t_{AL}$  is the test statistic for all items with a lower limit and  $t_{AU}$  is the test statistic for all items with an upper limit. For example, the test statistic for items above an upper limit of 5.5 with  $\bar{x} = 4.0$ ,  $s = 3.0$ , and  $n = 5$  is  $t_{AU} = (8.5 - 4.0)/3.0 = 1.5$  with  $n - 1 = 4$  degrees of freedom.

Instead of using sampling plans that specify an allowable fraction of defective items, it saves computations to simply write specifications in terms of the allowable test statistic values themselves. This procedure is equivalent to requiring that the sample average be at least a pre-specified number of standard deviations away from an upper or lower limit. For example, with  $\bar{x} = 4.0$ ,  $U = 8.5$ ,  $s = 3.0$  and  $n = 41$ , the sample mean is only about  $(8.5 - 4.0)/3.0 = 1.5$  standard deviations away from the upper limit.

To summarize, the application of sampling by variables requires the specification of a sample size, the relevant upper or limits, and either (1) the allowable fraction of items falling outside the designated limits or (2) the allowable probability that the population average falls outside the designated limit. Random samples are drawn from a pre-defined population and tested to obtain measured values of a variable attribute. From these measurements, the sample mean, standard deviation, and quality control test statistic are calculated. Finally, the test statistic is compared to the allowable trigger level and the lot is either accepted or rejected. It is also possible to apply sequential sampling in this procedure, so that a batch may be subjected to additional sampling and testing to further refine the test statistic values.

With sampling by variables, it is notable that a producer of material or work can adopt two general strategies for meeting the required specifications. First, a producer may insure that the average quality level is quite high, even if the variability among items is high. This strategy is illustrated in Figure 13-3 as a "high quality average" strategy. Second, a producer may meet a desired quality target by reducing the *variability* within each batch. In Figure 13-3, this is labeled the "low variability" strategy. In either case, a producer should maintain high standards to avoid rejection of a batch.

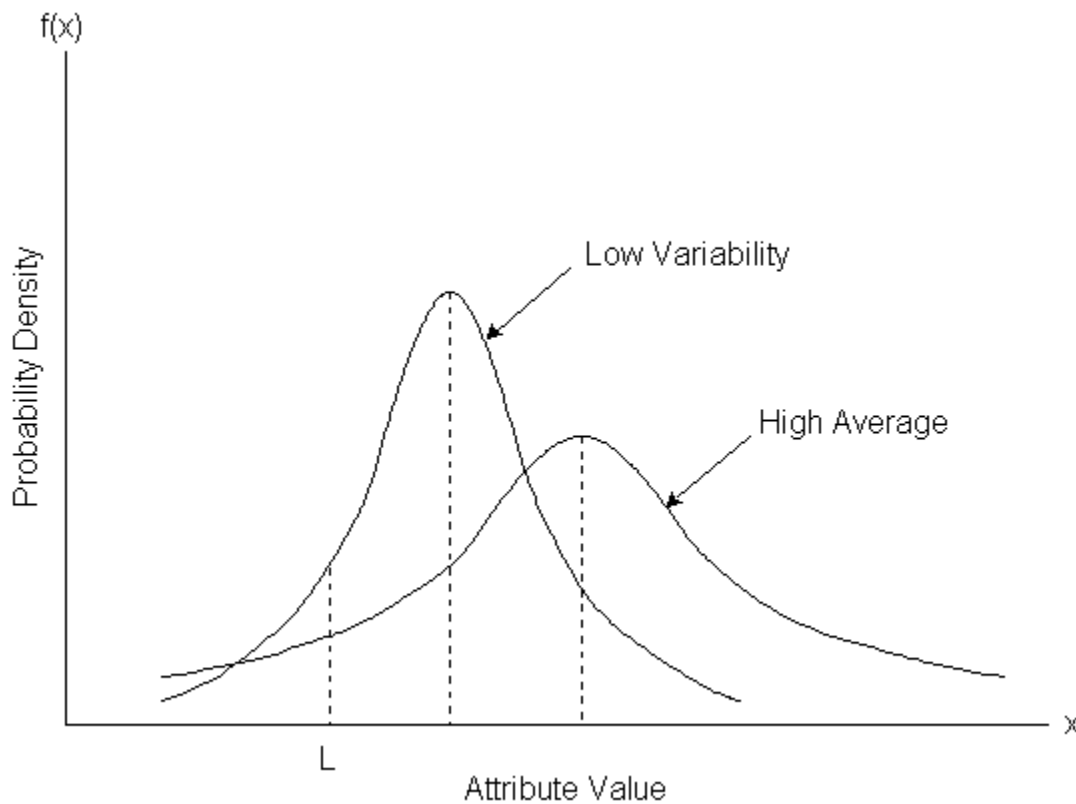

**Figure 13-3** Testing for Defective Component Strengths

### Example 13-5: Testing for defective component strengths

Suppose that an inspector takes eight strength measurements with the following results:

4.3, 4.8, 4.6, 4.7, 4.4, 4.6, 4.7, 4.6

In this case, the sample mean and standard deviation can be calculated using Equations (13.8) and (13.9):

$$\begin{aligned}\bar{x} &= 1/8(4.3 + 4.8 + 4.6 + 4.7 + 4.4 + 4.6 + 4.7 + 4.6) = 4.59 \\ s^2 &= [1/(8-1)][(4.3 - 4.59)^2 + (4.8 - 4.59)^2 + (4.6 - 4.59)^2 + (4.7 - 4.59)^2 + (4.4 - 4.59)^2 + (4.6 - 4.59)^2 + (4.7 - 4.59)^2 + (4.6 - 4.59)^2] = 0.16\end{aligned}$$

The percentage of items below a lower quality limit of  $L = 4.3$  is estimated from the test statistic  $t_{AL}$  in Equation (13.12):

$$t_{AU} = \frac{4.59 - 4.3}{0.16} = 1.81$$

[Back to top](#)

## 13.8 Safety

Construction is a relatively hazardous undertaking. As Table 13-1 illustrates, there are significantly more injuries and lost workdays due to injuries or illnesses in construction than in virtually any other industry. These work related injuries and illnesses are exceedingly costly. The *Construction Industry Cost Effectiveness Project* estimated that accidents cost \$8.9 billion or nearly seven percent of the \$137 billion (in 1979 dollars) spent annually for industrial, utility and commercial construction in the United States. [3] Included in this total are direct costs (medical costs, premiums for workers' compensation benefits, liability and property losses) as well as indirect costs (reduced worker productivity, delays in projects, administrative time, and damage to equipment and the facility). In contrast to most industrial accidents, innocent bystanders may also be injured by construction accidents. Several crane collapses from high rise buildings under construction have resulted in fatalities to passerbys. Prudent project managers and owners would like to reduce accidents, injuries and illnesses as much as possible.

**TABLE 13-1** Nonfatal Occupational Injury and Illness Incidence Rates

Industry	1996	2006
Agriculture, forestry, fishing	8.7	6
Mining	5.4	3.5
Construction	9.9	5.9
Manufacturing	10.6	6
Trade, Transportation and utilities	8.7	5
Financial activities	2.4	1.5
Professional and business services	6.0	1.2

Note: Data represent total number of cases per 100 full-time employees

Source: U.S. Bureau of Labor Statistics, *Occupational injuries and Illnesses in the United States by Industry*, annual

As with all the other costs of construction, it is a mistake for owners to ignore a significant category of costs such as injury and illnesses. While contractors may pay insurance premiums directly, these costs are reflected in bid prices or contract amounts. Delays caused by injuries and illnesses can present significant opportunity costs to owners. In the long run, the owners of constructed facilities must pay all the costs of construction. For the case of injuries and illnesses, this general principle might be slightly qualified since significant costs are borne by workers themselves or society at large. However, court judgements and insurance payments compensate for individual losses and are ultimately borne by the owners.

The causes of injuries in construction are numerous. Table 13-2 lists the reported causes of accidents in the US construction industry in 1997 and 2004. A similar catalogue of causes would exist for other countries. The largest single category for both injuries and fatalities are individual falls. Handling goods and transportation are also a significant cause of injuries. From a management perspective, however, these reported causes do not really provide a useful prescription for safety policies. An individual fall may be caused by a series of coincidences: a railing might not be secure, a worker might be inattentive, the footing may be slippery, etc. Removing any one of these compound causes might serve to prevent any particular accident. However, it is clear that conditions such as unsecured railings will normally increase the risk of accidents. Table 13-3 provides a more detailed list of causes of fatalities for construction sites alone, but again each fatality may have multiple causes.



**TABLE 13-2** Fatal Occupational Injuries in Construction, 1997 and 2004

Year	1997	2004
Total fatalities	1,107	1,234
Falls	376	445
Transportation incidents	288	287
Contact with objects & equipment	199	267
Exposure to harmful substances and environments	188	170

Source: Bureau of Labor Statistics

**TABLE 13-3** Fatality Causes in Construction, 1996/1997 and 2006/2007

Year	96/97	06/07
Total accidents	287	241
Falls from a height	88	45
Struck by a moving vehicle	43	30
Struck by moving/falling object	57	40
Trapped by something overturning/collapsing	16	19
Drowning/asphyxiation	9	16

Source: Bureau of Labor Statistics

Various measures are available to improve jobsite safety in construction. Several of the most important occur before construction is undertaken. These include design, choice of technology and education. By altering facility designs, particular structures can be safer or more hazardous to construct. For example, parapets can be designed to appropriate heights for construction worker safety, rather than the minimum height required by building codes.

Choice of technology can also be critical in determining the safety of a jobsite. Safeguards built into machinery can notify operators of problems or prevent injuries. For example, simple switches can prevent equipment from being operating when protective shields are not in place. With the availability of on-board electronics (including computer chips) and sensors, the possibilities for sophisticated machine controllers and monitors has greatly expanded for construction equipment and tools. Materials and work process choices also influence the safety of construction. For example, substitution of alternative materials for asbestos can reduce or eliminate the prospects of long term illnesses such as *asbestiosis*.

Educating workers and managers in proper procedures and hazards can have a direct impact on jobsite safety. The realization of the large costs involved in construction injuries and illnesses provides a considerable motivation for awareness and education. Regular safety inspections and safety meetings have become standard practices on most job sites.

Pre-qualification of contractors and sub-contractors with regard to safety is another important avenue for safety improvement. If contractors are only invited to bid or enter negotiations if they have an acceptable record of safety (as well as quality performance), then a direct incentive is provided to insure adequate safety on the part of contractors.

During the construction process itself, the most important safety related measures are to insure vigilance and cooperation on the part of managers, inspectors and workers. Vigilance involves considering the risks of different working practices. In also involves maintaining temporary physical safeguards such as barricades, braces, guylines, railings, toeboards and the like. Sets of standard practices are also important, such as: [\[4\]](#)

- requiring hard hats on site.
- requiring eye protection on site.
- requiring hearing protection near loud equipment.
- insuring safety shoes for workers.
- providing first-aid supplies and trained personnel on site

While eliminating accidents and work related illnesses is a worthwhile goal, it will never be attained. Construction has a number of characteristics making it inherently hazardous. Large forces are involved in many operations. The jobsite is continually changing as construction proceeds. Workers do not have fixed worksites and must move around a structure under construction. The tenure of a worker on a site is short, so the worker's familiarity and the employer-employee relationship are less settled than in manufacturing settings. Despite these peculiarities and as a result of exactly these special problems, improving worksite safety is a very important project management concern.

### **Example 13-6: Trench collapse** [\[5\]](#)

To replace 1,200 feet of a sewer line, a trench of between 12.5 and 18 feet deep was required down the center of a four lane street. The contractor chose to begin excavation of the trench from the shallower end, requiring a 12.5 deep trench. Initially, the contractor used a nine foot high, four foot wide steel trench box for soil support. A trench box is a rigid steel frame consisting of two walls supported by welded struts with open sides and ends. This method had the advantage that traffic could be maintained in at least two lanes during the reconstruction work.

In the shallow parts of the trench, the trench box seemed to adequately support the excavation. However, as the trench got deeper, more soil was unsupported below the trench box. Intermittent soil collapses in the trench began to occur. Eventually, an old parallel six inch water main collapsed, thereby saturating the soil and leading to massive soil collapse at the bottom of the trench. Replacement of the water main was added to the initial contract. At this point, the contractor began sloping the sides of the trench, thereby requiring the closure of the entire street.

The initial use of the trench box was convenient, but it was clearly inadequate and unsafe. Workers in the trench were in continuing danger of accidents stemming from soil collapse. Disruption to surrounding facilities such as the parallel water main was highly likely. Adoption of a tongue and groove vertical sheeting system over the full height of the trench or, alternatively, the sloping excavation eventually adopted are clearly preferable.

[Back to top](#)

## **13.9 References**

1. Ang, A.H.S. and W.H. Tang, *Probability Concepts in Engineering Planning and Design: Volume I - Basic Principles*, John Wiley and Sons, Inc., New York, 1975.

2. Au, T., R.M. Shane, and L.A. Hoel, *Fundamentals of Systems Engineering: Probabilistic Models*, Addison-Wesley Publishing Co., Reading MA, 1972
3. Bowker, A.H. and Liebermann, G. J., *Engineering Statistics*, Prentice-Hall, 1972.
4. Fox, A.J. and Cornell, H.A., (eds), *Quality in the Constructed Project*, American Society of Civil Engineers, New York, 1984.
5. International Organization for Standardization, "Sampling Procedures and Charts for Inspection by Variables for Percent Defective, ISO 3951-1981 (E)", *Statistical Methods*, ISO Standard Handbook 3, International Organization for Standardization, Paris, France, 1981.
6. Skibniewski, M. and Hendrickson, C., *Methods to Improve the Safety Performance of the U.S. Construction Industry*, Technical Report, Department of Civil Engineering, Carnegie Mellon University, 1983.
7. United States Department of Defense, *Sampling Procedures and Tables for Inspection by Variables*, (Military Standard 414), Washington D.C.: U.S. Government Printing Office, 1957.
8. United States Department of Defense, *Sampling Procedures and Tables for Inspection by Attributes*, (Military Standard 105D), Washington D.C.: U.S. Government Printing Office, 1963.

[Back to top](#)

## 13.10 Problems

1. Consider the following specification. Would you consider it to be a process or performance specification? Why?

"Water used in mixing or curing shall be reasonably clean and free of oil, salt, acid, alkali, sugar, vegetable, or other substance injurious to the finished product...Water known to be potable quality may be used without test. Where the source of water is relatively shallow, the intake shall be so enclosed as to exclude silt, mud, grass, or other foreign materials." [\[6\]](#)

2. Suppose that a sampling plan calls for a sample of size  $n = 50$ . To be acceptable, only three or fewer samples can be defective. Estimate the probability of accepting the lot if the average defective percentage is (a) 15%, (b) 5% or (c) 2%. Do not use an approximation in this calculation.
3. Repeat Problem 2 using the binomial approximation.
4. Suppose that a project manager tested the strength of one tile out of a batch of 3,000 to be used on a building. This one sample measurement was compared with the design specification and, in this case, the sampled tile's strength exceeded that of the specification. On this basis, the project manager accepted the tile shipment. If the sampled tile was defective (with a strength less than the specification), the project manager would have rejected the lot.
  - a. What is the probability that ninety percent of the tiles are substandard, even though the project manager's sample gave a satisfactory result?
  - b. Sketch out the operating characteristic curve for this sampling plan as a function of the actual fraction of defective tiles.
5. Repeat Problem 4 for sample sizes of (a) 5, (b) 10 and (c) 20.
6. Suppose that a sampling-by-attributes plan is specified in which ten samples are taken at random

from a large lot ( $N=100$ ) and at most one sample item is allowed to be defective for the lot to be acceptable.

- a. If the actual percentage defective is five percent, what is the probability of lot acceptance? (Note: you may use relevant approximations in this calculation.)
  - b. What is the consumer's risk if an acceptable quality level is fifteen percent defective and the actual fraction defective is five percent?
  - c. What is the producer's risk with this sampling plan and an eight percent defective percentage?
7. The yield stress of a random sample of 25 pieces of steel was measured, yielding a mean of 52,800 psi. and an estimated standard deviation of  $s = 4,600$  psi.
- a. What is the probability that the population mean is less than 50,000 psi?
  - b. What is the estimated fraction of pieces with yield strength less than 50,000 psi?
  - c. Is this sampling procedure sampling-by-attributes or sampling-by-variable?
8. Suppose that a contract specifies a sampling-by-attributes plan in which ten samples are taken at random from a large lot ( $N=100$ ) and at most one sample is allowed to be defective for the lot to be acceptable.
- a. If the actual percentage defective is five percent, what is the probability of lot acceptance? (Note: you may use relevant approximations in this calculation).
  - b. What is the consumer's risk if an acceptable quality level is fifteen percent defective and the actual fraction defective is 0.05?
  - c. What is the producer's risk with this sampling plan and a 8% defective percentage?
9. In a random sample of 40 blocks chosen from a production line, the mean length was 10.63 inches and the estimated standard deviation was 0.4 inch. Between what lengths can it be said that 98% of block lengths will lie?

[Back to top](#)

## 13.11 Footnotes

1. This illustrative pay factor schedule is adapted from R.M. Weed, "Development of Multicharacteristic Acceptance Procedures for Rigid Pavement," *Transportation Research Record* 885, 1982, pp. 25-36. [Back](#)
2. B.A. Gilly, A. Touran, and T. Asai, "Quality Control Circles in Construction," *ASCE Journal of Construction Engineering and Management*, Vol. 113, No. 3, 1987, pg 432. [Back](#)
3. See *Improving Construction Safety Performance*, Report A-3, The Business Roundtable, New York, NY, January 1982. [Back](#)
4. Hinze, Jimmie W., *Construction Safety*, Prentice-Hall, 1997. [Back](#)
5. This example was adapted from E. Elinski, *External Impacts of Reconstruction and Rehabilitation Projects with Implications for Project Management*, Unpublished MS Thesis, Department of Civil Engineering, Carnegie Mellon University, 1985. [Back](#)

6. American Association of State Highway and Transportation Officials, *Guide Specifications for Highway Construction*, Washington, D.C., Section 714.01, pg. 244. [Back](#)

[Previous Chapter](#) | [Table of Contents](#) | [Next Chapter](#)

<a href="#">Go Up to Table of Contents</a>	
<a href="#">Go To Chapter 13 (Quality Control and Safety During Construction)</a>	<a href="#">Go To Chapter 14 (Organization and Use of Project Information)</a>
<i>Organization and Use of Project Information</i>	
<a href="#">Types of Project Information</a>	
<a href="#">Accuracy and Use of Information</a>	
<a href="#">Computerized Organization and Use of Information</a>	
<a href="#">Organizing Information in Databases</a>	
<a href="#">Relational Model of Databases</a>	
<a href="#">Other Conceptual Models of Databases</a>	
<a href="#">Centralized Database Management Systems</a>	
<a href="#">Databases and Applications Programs</a>	
<a href="#">Information Transfer and Flow</a>	
<a href="#">References</a>	
<a href="#">Problems</a>	
<a href="#">Footnotes</a>	

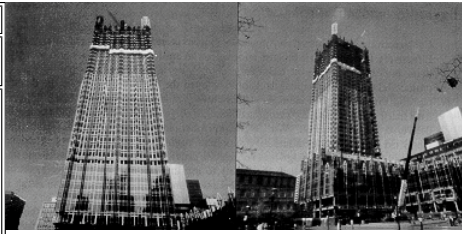

[http://pmbook.ce.cmu.edu/14\\_Organization\\_and\\_Use\\_of\\_Project\\_Information.html](http://pmbook.ce.cmu.edu/14_Organization_and_Use_of_Project_Information.html)

## 14. Organization and Use of Project Information

### 14.1 Types of Project Information

Construction projects inevitably generate enormous and complex sets of information. Effectively managing this bulk of information to insure its availability and accuracy is an important managerial task. Poor or missing information can readily lead to project delays, uneconomical decisions, or even the complete failure of the desired facility. Pity the owner and project manager who suddenly discover on the expected delivery date that important facility components have not yet been fabricated and cannot be delivered for six months! With better information, the problem could have been identified earlier, so that alternative suppliers might have been located or schedules arranged. Both project design and control are crucially dependent upon accurate and timely information, as well as the ability to use this information effectively. At the same time, too much unorganized information presented to managers can result in confusion and paralysis of decision making.

As a project proceeds, the types and extent of the information used by the various organizations involved will change. A listing of the most important information sets would include:

- cash flow and procurement accounts for each organization,
- intermediate analysis results during planning and design,
- design documents, including drawings and specifications,
- construction schedules and cost estimates,
- quality control and assurance records,
- chronological files of project correspondence and memorandum,
- construction field activity and inspection logs,
- legal contracts and regulatory documents.

Some of these sets of information evolve as the project proceeds. The financial accounts of payments over the entire course of the project is an example of overall growth. The passage of time results in steady additions in these accounts, whereas the addition of a new actor such as a contractor leads to a sudden jump in the number of accounts. Some information sets are important at one stage of the process but may then be ignored. Common examples include planning or structural analysis databases which are not ordinarily used during construction or operation. However, it may be necessary at later stages in the project to re-do analyses to consider desired changes. In this case, archival information storage and retrieval become important. Even after the completion of construction, an historical record may be important for use during operation, to assess responsibilities in case of facility failures or for planning similar projects elsewhere.

The control and flow of information is also important for collaborative work environments, where many professionals are working on different aspects of a project and sharing information. Collaborative work environments provide facilities for sharing datafiles, tracing decisions, and communication via electronic mail or video conferencing. The datastores in these collaborative work environments may become very large.

Based on several construction projects, Maged Abdelsayed of Tardif, Murray & Assoc (Quebec, Canada) estimated the following average figures for a typical project of US\$10 million:

- Number of participants (companies): 420 (including all suppliers and sub-sub-contractors)
- Number of participants (individuals): 850
- Number of different types of documents generated: 50
- Number of pages of documents: 56,000
- Number of bankers boxes to hold project documents: 25
- Number of 4 drawers filing cabinets: 6
- Number of 20inch diameter, 20 year old, 50 feet high, trees used to generate this volume of paper: 6
- Equivalent number of Mega Bytes of electronic data to hold this volume of paper (scanned): 3,000 MB
- Equivalent number of compact discs (CDs): 6

While there may be substantial costs due to inaccurate or missing information, there are also significant costs associated with the generation, storage, transfer, retrieval and other manipulation of information. In addition to the costs of clerical work and providing aids such as computers, the organization and review of information command an inordinate amount of the attention of project managers, which may be the scarcest resource on any construction project. It is useful, therefore, to understand the scope and alternatives for organizing project information.

[Back to top](#)

### 14.2 Accuracy and Use of Information

Numerous sources of error are expected for project information. While numerical values are often reported to the nearest cent or values of equivalent precision, it is rare that the actual values are so accurately known. Living with some uncertainty is an inescapable situation, and a prudent manager should have an understanding of the uncertainty in different types of information and the possibility of drawing misleading conclusions.

We have already discussed the uncertainty inherent in making forecasts of project costs and durations sometime in the future. Forecast uncertainty also exists in the short term. For example, consider estimates of work completed. Every project manager is familiar with situations in which the final few bits of work for a task take an inordinate amount of time. Unforeseen problems, inadequate quality on already completed work, lack of attention, accidents, or postponing the most difficult work problems to the end can all contribute to making the final portion of an activity actually require far more time and effort than expected. The net result is that estimates of the actual proportion of

work completed are often inaccurate.

Some inaccuracy in reports and estimates can arise from conscious choices made by workers, foremen or managers. If the value of insuring accuracy is thought to be low or nonexistent, then a rational worker will not expend effort or time to gather or to report information accurately. Many project scheduling systems flounder on exactly this type of non-reporting or mis-reporting. The original schedule can quickly become extremely misleading without accurate updating! Only if all parties concerned have specific mandates or incentives to report accurately will the data be reliable.

Another source of inaccuracy comes from transcription errors of various sorts. Typographical errors, incorrect measurements from reading equipment, or other recording and calculation errors may creep into the sets of information which are used in project management. Despite intensive efforts to check and eliminate such errors, their complete eradication is virtually impossible.

One method of indicating the relative accuracy of numerical data is to report ranges or expected deviations of an estimate or measurement. For example, a measurement might be reported as 198 ft.  $\pm$  2 ft. There are two common interpretations of these deviations. First, a range (such as  $\pm 2$ ) might be chosen so that the actual value is *certain* to be within the indicated range. In the case above, the actual length would be somewhere between 196 and 200 feet with this convention. Alternatively, this deviation might indicate the *typical* range of the estimate or measurement. In this case, the example above might imply that there is, say, a two-thirds chance that the actual length is between 196 and 200.

When the absolute range of a quantity is very large or unknown, the use of a statistical standard deviation as a measure of uncertainty may be useful. If a quantity is measured  $n$  times resulting in a set of values  $x_i$  ( $i = 1, 2, \dots, n$ ), then the average or mean value then the average or mean value is given by:

$$(14.1) \quad \bar{x} = \sum_{i=1}^n \frac{x_i}{n}$$

The standard deviation  $\sigma$  can be estimated as the square root of the sample variance  $s^2$ , i.e.  $\sigma \approx s$ , where:

$$(14.2) \quad s^2 = \frac{\sum_{i=1}^n (x_i - \bar{x})^2}{n - 1}$$

The standard deviation  $\sigma$  is a direct indicator of the spread or variability in a measurement, in the same units as the measurement itself. Higher values of the standard deviation indicate greater and greater uncertainty about the exact value of the measurement. For the commonly encountered *normal distribution* of a random variable, the average value plus or minus one standard deviation,  $\mu \pm \sigma$ , will include about two-thirds of the actual occurrences. A related measure of random variability is the coefficient of variation, defined as the ratio of the standard deviation to the mean:

$$(14.3) \quad c = \frac{\sigma}{\mu}$$

Thus, a coefficient of variation indicates the variability as a proportion of the expected value. A coefficient of variation equal to one ( $c = 1$ ) represents substantial uncertainty, whereas a value such as  $c = 0.1$  or ten percent indicates much smaller variability.

More generally, even information which is gathered and reported correctly may be interpreted incorrectly. While the actual information might be correct within the terms of the data gathering and recording system, it may be quite misleading for managerial purposes. A few examples can illustrate the problems which may arise in naively interpreting recorded information without involving any conceptual understanding of how the information is actually gathered, stored and recorded or how work on the project actually proceeds.

#### Example 14-1: Sources of Delay and Cost Accounts

It is common in construction activity information to make detailed records of costs incurred and work progress. It is less common to keep detailed records of delays and their causes, even though these delays may be the actual cause of increased costs and lower productivity. [1] Paying exclusive attention to *cost* accounts in such situations may be misleading. For example, suppose that the accounts for equipment and material inventories show cost savings relative to original estimates, whereas the costs associated with particular construction activities show higher than estimated expenditures. In this situation, it is not necessarily the case that the inventory function is performing well, whereas the field workers are the cause of cost overrun problems. It may be that construction activities are delayed by lack of equipment or materials, thus causing cost increases. Keeping a larger inventory of materials and equipment might increase the inventory account totals, but lead to lower overall costs on the project. Better yet, more closely matching demands and supplies might reduce delay costs without concurrent inventory cost increases. Thus, simply examining cost account information may not lead to a correct diagnosis of a problem or to the correct managerial responses.

#### Example 14-2: Interest Charges

Financial or interest charges are usually accumulated in a separate account for projects, while the accounts associated with particular activities represent actual expenditures. For example, planning activities might cost \$10,000 for a small project during the first year of a two year project. Since dollar expenditures have a time value, this \$10,000 cost in year 1 is *not* equivalent in value to a \$10,000 cost in year 2. In particular, financing the early \$10,000 involves payment of interest or, similarly, the loss of investment opportunities. If the borrowing rate was 10%, then financing the first year \$10,000 expenditure would require  $\$10,000 \times 0.10 = \$1,000$  and the value of the expenditure by the end of the second year of the project would be \$11,000. Thus, some portion of the overall interest charges represents a cost associated with planning activities. Recognizing the true value of expenditures made at different periods of time is an important element in devising rational planning and management strategies.

[Back to top](#)

## 14.3 Computerized Organization and Use of Information

Numerous formal methods and possible organizations exist for the information required for project management. Before discussing the details of computations and information representation, it will be useful to describe a record keeping implementation, including some of the practical concerns in design and implementation. In this section, we shall describe a computer based system to provide construction yard and warehouse management information from the point of view of the system users. [2] In the process, the usefulness of computerized databases can be illustrated.

A yard or warehouse is used by most construction firms to store equipment and to provide an inventory of materials and parts needed for projects. Large firms may have several warehouses at different locations so as to reduce transit time between project sites and materials supplies. In addition, local "yards" or "equipment sheds" are

commonly provided on the job site. Examples of equipment in a yard would be drills, saws, office trailers, graders, back hoes, concrete pumps and cranes. Material items might include nails, plywood, wire mesh, forming lumber, etc.

In typical construction warehouses, written records are kept by warehouse clerks to record transfer or return of equipment to job sites, dispatch of material to jobs, and maintenance histories of particular pieces of equipment. In turn, these records are used as the basis for billing projects for the use of equipment and materials. For example, a daily charge would be made to a project for using a concrete pump. During the course of a month, the concrete pump might spend several days at different job sites, so each project would be charged for its use. The record keeping system is also used to monitor materials and equipment movements between sites so that equipment can be located.

One common mechanism to organize record keeping is to fill out cards recording the transfer of items to or from a job site. Table 14-1 illustrates one possible transfer record. In this case, seven items were requested for the Carnegie-Mellon job site (project number 83-1557). These seven items would be loaded on a delivery truck, along with a copy of the transfer record. Shown in Table 14-1 is a code number identifying each item (0609.02, 0609.03, etc.), the quantity of each item requested, an item description and a unit price. For equipment items, an equipment number identifying the individual piece of equipment used is also recorded, such as grinder No. 4517 in Table 14-1; a unit price is not specified for equipment but a daily rental charge might be imposed.

**TABLE 14-1** Illustration of a Construction Warehouse Transfer Record

TRANSFER SHEET NUMBER 100311				
Deliver To: Carnegie-Mellon			Job No. 83-1557	
Received From: Pittsburgh Warehouse			Job No. 99-PITT	
ITEM NO.	EQ. NO.	QTY	DESCRIPTION	UNIT PRICE
0609.02		200	Hilti Pins NK27	\$0.36
0609.03		200	Hilti Pins NK27	0.36
0188.21		1	Kiel, Box of 12	6.53
0996.01		3	Paint, Spray	5.57
0607.03		4	Plywood, 4 x 8 x 1/4"	11.62
0172.00	4517	1	Grinder	
0181.53		1	Grinding Wheel, 6" Cup	14.97
Preparer: Vicki			Date: x/xx/xx	

Transfer sheets are numbered (such as No. 100311 in Table 14-1), dated and the preparer identified to facilitate control of the record keeping process. During the course of a month, numerous transfer records of this type are accumulated. At the end of a month, each of the transfer records is examined to compile the various items or equipment used at a project and the appropriate charges. Constructing these bills would be a tedious manual task. Equipment movements would have to be tracked individually, days at each site counted, and the daily charge accumulated for each project. For example, Table 14-1 records the transfer of grinder No. 4517 to a job site. This project would be charged a daily rental rate until the grinder was returned. Hundreds or thousands of individual item transfers would have to be examined, and the process of preparing bills could easily require a week or two of effort.

In addition to generating billing information, a variety of reports would be useful in the process of managing a company's equipment and individual projects. Records of the history of use of particular pieces of equipment are useful for planning maintenance and deciding on the sale or scrapping of equipment. Reports on the cumulative amount of materials and equipment delivered to a job site would be of obvious benefit to project managers. Composite reports on the amount, location, and use of pieces of equipment of particular types are also useful in making decisions about the purchase of new equipment, inventory control, or for project planning. Unfortunately, producing each of these reports requires manually sifting through a large number of transfer cards. Alternatively, record keeping for these specific projects could have to proceed by keeping multiple records of the same information. For example, equipment transfers might be recorded on (1) a file for a particular piece of equipment and (2) a file for a particular project, in addition to the basic transfer form illustrated in Table 14-1. Even with these redundant records, producing the various desired reports would be time consuming.

Organizing this inventory information in a computer program is a practical and desirable innovation. In addition to speeding up billing (and thereby reducing borrowing costs), application programs can readily provide various reports or *views* of the basic inventory information described above. Information can be entered directly to the computer program as needed. For example, the transfer record shown in Table 14-1 is based upon an input screen to a computer program which, in turn, had been designed to duplicate the manual form used prior to computerization. Use of the computer also allows some interactive aids in preparing the transfer form. This type of aid follows a simple rule: "Don't make the user provide information that the system already knows." [3] In using the form shown in Table 14-1, a clerk need only enter the code and quantity for an item; the verbal description and unit cost of the item then appear automatically. A copy of the transfer form can be printed locally, while the data is stored in the computer for subsequent processing. As a result, preparing transfer forms and record keeping are rapidly and effectively performed.

More dramatically, the computerized information allows warehouse personnel both to ask questions about equipment management and to readily generate the requisite data for answering such questions. The records of transfers can be readily processed by computer programs to develop bills and other reports. For example, proposals to purchase new pieces of equipment can be rapidly and critically reviewed after summarizing the actual usage of existing equipment. Ultimately, good organization of information will typically lead to the desire to store new types of data and to provide new views of this information as standard managerial tools.

Of course, implementing an information system such as the warehouse inventory database requires considerable care to insure that the resulting program is capable of accomplishing the desired task. In the warehouse inventory system, a variety of details are required to make the computerized system an acceptable alternative to a long standing manual record keeping procedure. Coping with these details makes a big difference in the system's usefulness. For example, changes to the status of equipment are generally made by recording transfers as illustrated in Table 14-1. However, a few status changes are not accomplished by physical movement. One example is a charge for air conditioning in field trailers: even though the air conditioners may be left in the field, the construction project should not be charged for the air conditioner after it has been turned off during the cold weather months. A special status change report may be required for such details. Other details of record keeping require similar special controls.

Even with a capable program, simplicity of design for users is a critical factor affecting the successful implementation of a system. In the warehouse inventory system described above, input forms and initial reports were designed to duplicate the existing manual, paper-based records. As a result, warehouse clerks could readily understand what information was required and its ultimate use. A good rule to follow is the Principle of Least Astonishment: make communications with users as consistent and predictable as possible in designing programs.

Finally, flexibility of systems for changes is an important design and implementation concern. New reports or views of the data is a common requirement as the system is used. For example, the introduction of a new accounting system would require changes in the communications procedure from the warehouse inventory system to record changes and other cost items.

In sum, computerizing the warehouse inventory system could save considerable labor, speed up billing, and facilitate better management control. Against these advantages must be placed the cost of introducing computer hardware and software in the warehouse.

[Back to top](#)

## 14.4 Organizing Information in Databases

Given the bulk of information associated with construction projects, formal organization of the information is essential so as to avoid chaos. Virtually all major firms in the



arena of project management have computer based organization of cost accounts and other data. With the advent of micro-computer database managers, it is possible to develop formal, computerized databases for even small organizations and projects. In this section, we will discuss the characteristics of such formal databases. Equivalent organization of information for *manual* manipulation is possible but tedious. Computer based information systems also have the significant advantage of rapid retrieval for immediate use and, in most instances, lower overall costs. For example, computerized specifications writing systems have resulted in well documented savings. These systems have records of common specification phrases or paragraphs which can be tailored to specific project applications. [4]

Formally, a database is a collection of stored operational information used by the management and application systems of some particular enterprise. [5] This stored information has explicit associations or relationships depending upon the content and definition of the stored data, and these associations may themselves be considered to be part of the database. Figure 14-1 illustrates some of the typical elements of a database. The *internal model* is the actual location and representation of the stored data. At some level of detail, it consists of the strings of "bits" which are stored in a computer's memory, on the tracks of a recording disk, on a tape, or on some other storage device.

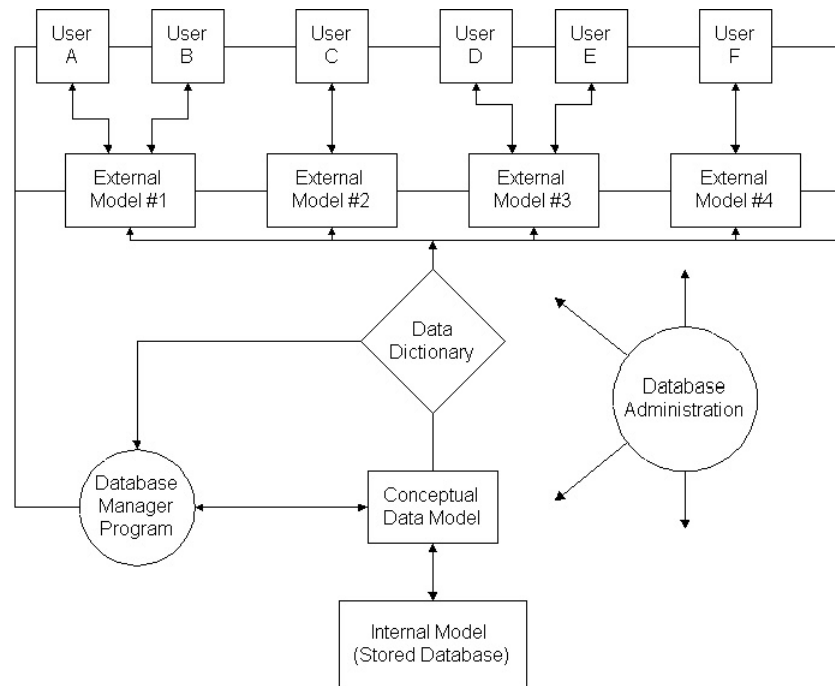

Figure 14-1 Illustration of a Database Management System Architecture

A manager need not be concerned with the details of data storage since this internal representation and manipulation is regulated by the *Database Manager Program* (DBM). The DBM is the software program that directs the storage, maintenance, manipulation and retrieval of data. Users retrieve or store data by issuing specific requests to the DBM. The objective of introducing a DBM is to free the user from the detail of exactly how data are stored and manipulated. At the same time, many different users with a wide variety of needs can use the same database by calling on the DBM. Usually the DBM will be available to a user by means of a special query language. For example, a manager might ask a DBM to report on all project tasks which are scheduled to be underway on a particular date. The desirable properties of a DBM include the ability to provide the user with ready access to the stored data and to maintain the integrity and security of the data. Numerous commercial DBM exist which provide these capabilities and can be readily adopted to project management applications.

While the actual storage of the information in a database will depend upon the particular machine and storage media employed, a *Conceptual Data Model* exists which provides the user with an idea or abstract representation of the data organization. (More formally, the overall configuration of the information in the database is called the *conceptual schema*.) For example, a piece of data might be viewed as a particular value within a *record* of a datafile. In this conceptual model, a datafile for an application system consists of a series of records with pre-defined variables within each record. A record is simply a sequence of variable values, which may be text characters or numerals. This datafile model is one of the earliest and most important data organization structures. But other views of data organization exist and can be exceedingly useful. The next section describes one such general model, called the relational model.

Continuing with the elements in Figure 14-1, the *data dictionary* contains the definitions of the information in the database. In some systems, data dictionaries are limited to descriptions of the items in the database. More general systems employ the data dictionary as the information source for anything dealing with the database systems. It documents the design of the database: what data are stored, how the data is related, what are the allowable values for data items, etc. The data dictionary may also contain user authorizations specifying who may have access to particular pieces of information. Another important element of the data dictionary is a specification of allowable ranges for pieces of data; by prohibiting the input of erroneous data, the accuracy of the database improves.

*External models* are the means by which the users view the database. Of all the information in the database, one particular user's view may be just a subset of the total. A particular view may also require specific translation or manipulation of the information in the database. For example, the *external model* for a paycheck writing program might consist solely of a list of employee names and salary totals, even if the underlying database would include employee hours and hourly pay rates. As far as that program is concerned, no other data exists in the database. The DBM provides a means of translating particular external models or views into the overall data model. Different users can *view* the data in quite distinct fashions, yet the data itself can be centrally stored and need not be copied separately for each user. External models provide the format by which any specific information needed is retrieved. Database "users" can be human operators or other application programs such as the paycheck writing program mentioned above.

Finally, the *Database Administrator* is an individual or group charged with the maintenance and design of the database, including approving access to the stored information. The assignment of the database administrator should not be taken lightly. Especially in large organizations with many users, the database administrator is vital to the success of the database system. For small projects, the database administrator might be an assistant project manager or even the project manager.

[Back to top](#)

## 14.5 Relational Model of Databases

As an example of how data can be organized conceptually, we shall describe the *relational data model*. In this conceptual model, the data in the database is viewed as being organized into a series of *relations* or tables of data which are associated in ways defined in the data dictionary. A relation consists of rows of data with columns containing particular attributes. The term "relational" derives from the mathematical theory of relations which provides a theoretical framework for this type of data model. Here, the terms "relation" and data "table" will be used interchangeably. Table 14-2 defines one possible relation to record unit cost data associated with particular activities. Included in the database would be one row (or *tuple*) for each of the various items involved in construction or other project activities. The unit cost information associated with each item is then stored in the form of the relation defined in Table 14-2.

**TABLE 14-2** Illustration of a Relation Description: Unit Price Information Attributes

Attribute Name	Attribute Description	Attribute Type	Key
ITEM_CODE	Item Code Number	Pre-defined Code	Yes
DESCRIPTION	Item Description	Text	No
WORK_UNIT	Standard Unit of Work for the Item	Text (restricted to allowable units)	No
CREW_CODE	Standard Crew Code for Activity	Pre-defined Code	No
OUTPUT	Average Productivity of Crew	Numerical	No
TIME_UNIT	Standard Unit of OUTPUT	Text	No
MATL_UNIT_COST	Material Unit Cost	Numerical	No
DATEMCOS	Date of MATL_UNIT_COST	Date Text	No
INSTCOST	Installation Unit Cost	Numerical	No
DATEICOS	Date of INSTCOST	Date Text	No

Using Table 14-2, a typical unit cost entry for an activity in construction might be:

ITEM\_CODE: 04.2-66-025  
 DESCRIPTION: common brick masonry, 12" thick wall, 19.0 bricks per S.F.  
 WORK\_UNIT: 1000 bricks  
 CREW\_CODE: 04.2-3  
 OUTPUT: 1.9  
 TIME\_UNIT: Shift  
 MATL\_UNIT\_COST: 124  
 DATEMCOS: June-09-79  
 INSTCOST: 257  
 DATEICOS: August-23-79

This entry summarizes the unit costs associated with construction of 12" thick brick masonry walls, as indicated by the item DESCRIPTION. The ITEM\_CODE is a numerical code identifying a particular activity. This code might identify general categories as well; in this case, 04.2 refers to general masonry work. ITEM\_CODE might be based on the MASTERFORMAT or other coding scheme. The CREW\_CODE entry identifies the standard crew which would be involved in the activity. The actual composition of the standard crew would be found in a CREW RELATION under the entry 04.2-3, which is the third standard crew involved in masonry work (04.2). This ability to *point* to other relations reduces the *redundancy* or duplication of information in the database. In this case, standard crew number 04.2-3 might be used for numerous masonry construction tasks, but the definition of this crew need only appear once.

WORK\_UNIT, OUTPUT and TIME\_UNIT summarize the expected output for this task with a standard crew and define the standard unit of measurement for the item. In this case, costs are given per thousand bricks per shift. Finally, material (MATL\_UNIT\_COST) and installation (INSTCOSTS) costs are recorded along with the date (DATEMCOS and DATEICOS) at which the prices were available and entered in the database. The date of entry is useful to insure that any inflation in costs can be considered during use of the data.

The data recorded in each row could be obtained by survey during bid preparations, from past project experience or from commercial services. For example, the data recorded in the Table 14-2 relation could be obtained as nationwide averages from commercial sources.

An advantage of the relational database model is that the number of attributes and rows in each relation can be expanded as desired. For example, a manager might wish to divide material costs (MATL\_UNIT\_COST) into attributes for specific materials such as cement, aggregate and other ingredients of concrete in the unit cost relation defined in Table 14-2. As additional items are defined or needed, their associated data can be entered in the database as another row (or tuple) in the unit cost relation. Also, new relations can be defined as the need arises. Hence, the relational model of database organization can be quite flexible in application. In practice, this is a crucial advantage. Application systems can be expected to change radically over time, and a flexible system is highly desirable.

With a relational database, it is straightforward to issue queries for particular data items or to combine data from different relations. For example, a manager might wish to produce a report of the crew composition needed on a site to accomplish a given list of tasks. Assembling this report would require accessing the unit price information to find the standard crew and then combining information about the construction activity or item (eg. quantity desired) with crew information. However, to effectively accomplish this type of manipulation requires the definition of a "key" in each relation.

In Table 14-2, the ITEM\_CODE provides a unique identifier or *key* for each row. No other row should have the same ITEM\_CODE in any one relation. Having a unique key reduces the *redundancy* of data, since only one row is included in the database for each activity. It also avoids error. For example, suppose one queried the database to find the material cost entered on a particular date. This response might be misleading since more than one material cost could have been entered on the same date. Similarly, if there are multiple rows with the same ITEM\_CODE value, then a query might give erroneous responses if one of the rows was out of date. Finally, each row has only a single entry for each attribute. [6]

The ability to combine or separate relations into new arrangements permits the definition of alternative *views* or external models of the information. Since there are usually a number of different users of databases, this can be very useful. For example, the payroll division of an organization would normally desire a quite different organization of information about employees than would a project manager. By explicitly defining the type and organization of information a particular user group or application requires, a specific view or subset of the entire database can be constructed. This organization is illustrated in Fig. 14-1 with the DATA DICTIONARY serving as a translator between the external data models and the database management system.

Behind the operations associated with querying and manipulating relations is an explicit algebraic theory. This algebra defines the various operations that can be performed on relations, such as union (consisting of all rows belonging to one or the other of two relations), intersection (consisting of all rows belonging to both of two relations), minus (consisting of all rows belonging to one relation and not another), or projection (consisting of a subset of the attributes from a relation). The algebraic underpinnings of relational databases permits rigorous definitions and confidence that operations will be accomplished in the desired fashion. [7]

### Example 14-3: A Subcontractor Relation

As an illustration of the preceding discussion, consider the problem of developing a database of possible subcontractors for construction projects. This database

might be desired by the cost estimation department of a general contractor to identify subcontractors to ask to bid on parts of a project. Appropriate subcontractors appearing in the database could be contacted to prepare bids for specific projects. Table 14-3 lists the various attributes which might be required for such a list and an example entry, including the subcontractor's name, contact person, address, size (large, medium or small), and capabilities.

**TABLE 14-3** Subcontractor Relation Example

Attribute	Example
NAME	XYZ Electrical Co.
CONTACT	Betty XYZ
PHONE	(412) xxx-xxxx
STREET	xxx Mulberry St.
CITY	Pittsburgh
STATE	PA
ZIPCODE	152xx
SIZE	large
CONCRETE	no
ELECTRICAL	yes
MASONRY	no
etc.	

To use this relation, a cost estimator might be interested in identifying large, electrical subcontractors in the database. A query typed into the DBM such as:

```
SELECT from SUBCONTRACTORS
where SIZE = Large and ELECTRICAL = Yes
```

would result in the selection of all large subcontractors performing electrical work in the subcontractor's relation. More specifically, the estimator might want to find subcontractors in a particular state:

```
SELECT from SUBCONTRACTORS
where SIZE = Large and ELECTRICAL = Yes and STATE = VI.
```

In addition to providing a list of the desired subcontractors' names and addresses, a utility application program could also be written which would print mailing labels for the selected firms.

Other portions of the general contracting firm might also wish to use this list. For example, the accounting department might use this relation to record the addresses of subcontractors for payment of invoices, thereby avoiding the necessity to maintain duplicate files. In this case, the accounting code number associated with each subcontractor might be entered as an additional attribute in the relation, and the accounting department could find addresses directly.

#### Example 14-4: Historical Bridge Work Relation

As another simple example of a data table, consider the relation shown in Table 14-0 which might record historical experience with different types of bridges accumulated by a particular agency. The actual instances or rows of data in Table 14-4 are hypothetical. The attributes of this relation are:

- PROJECT NUMBER - a 6-digit code identifying the particular project.
- TYPE OF BRIDGE - a text field describing the bridge type. (For retrieval purposes, a numerical code might also be used to describe bridge type to avoid any differences in terminology to describe similar bridges).
- LOCATION - The location of the project.
- CROSSING - What the bridge crosses over, eg. a river.
- SITE CONDITIONS - A brief description of the site peculiarities.
- ERECTION TIME - Time required to erect a bridge, in months.
- SPAN - Span of the bridge in feet.
- DATE - Year of bridge completion.
- ACTUAL-ESTIMATED COSTS - Difference of actual from estimated costs.

These attributes could be used to answer a variety of questions concerning construction experience useful during preliminary planning.

**TABLE 14-4** Example of Bridge Work Relation

Project Number	Type of Bridge	Location	Crossing	Site Conditions	Erection Time (Months)	Span (ft.)	Estimated less Actual Cost
169137	Steel Plate Girder	Altoona	Railroad	200' Valley Limestone	5	240	-\$50,000
170145	Concrete Arch	Pittsburgh	River	250' High Sandy Loam	7	278	-27,500
197108	Steel Truss	Allentown	Highway	135' Deep Pile Foundation	8	256	35,000

As an example, suppose that a bridge is to be built with a span of 250 feet, located in Pittsburgh PA, and crossing a river with limestone sub-strata. In initial or preliminary planning, a designer might query the database four separate times as follows:

- SELECT from BRIDGEWORK where SPAN > 200 and SPAN < 300 and where CROSSING = "river"
- SELECT from BRIDGEWORK where SPAN > 200 and SPAN < 300 and where SITE CONDITIONS = "Limestone"
- SELECT from BRIDGEWORK where TYPE OF BRIDGE = "Steel Plate Girder" and LOCATION = "PA"
- SELECT from BRIDGEWORK where SPAN < 300 and SPAN > 200 and ESTIMATED LESS ACTUAL COST < 100,000.

Each SELECT operation would yield the bridge examples in the database which corresponds to the desired selection criteria. In practice, an input/output interpreter program should be available to translate these inquiries to and from the DBM and an appropriate problem oriented language.

The four queries may represent subsequent thoughts of a designer faced with these problem conditions. He or she may first ask, "What experience have we had with bridges of this span over rivers?" "What experience have we had with bridges of this span with these site conditions? What is our experience with steel girder bridges in Pennsylvania? For bridges of this span, how many and which were erected without a sizable cost overrun? We could pose many more questions of this general type using only the small data table shown in Table 14-4.

[Back to top](#)

## 14.6 Other Conceptual Models of Databases

While the relational model offers a considerable amount of flexibility and preserves considerable efficiency, there are several alternative models for organizing databases, including network and hierarchical models. The hierarchical model is a tree structure in which information is organized as branches and nodes from a particular base. [8] As an example, Figure 14-2 illustrates a hierarchical structure for rented equipment costs. In this case, each piece of equipment belongs to a particular supplier and has a cost which might vary by the duration of use. To find the cost of a particular piece of equipment from a particular supplier, a query would first find the supplier, then the piece of equipment and then the relevant price.

The hierarchical model has the characteristic that each item has a single predecessor and a variable number of subordinate data items. This structure is natural for many applications, such as the equipment cost information described above. However, it might be necessary to construct similar hierarchies for each project to record the equipment used or for each piece of equipment to record possible suppliers. Otherwise, generating these lists of assignments from the database illustrated in Figure 14-2 would be difficult. For example, finding the least expensive supplier of a crane might involve searching every supplier and every equipment node in the database to find all crane prices.

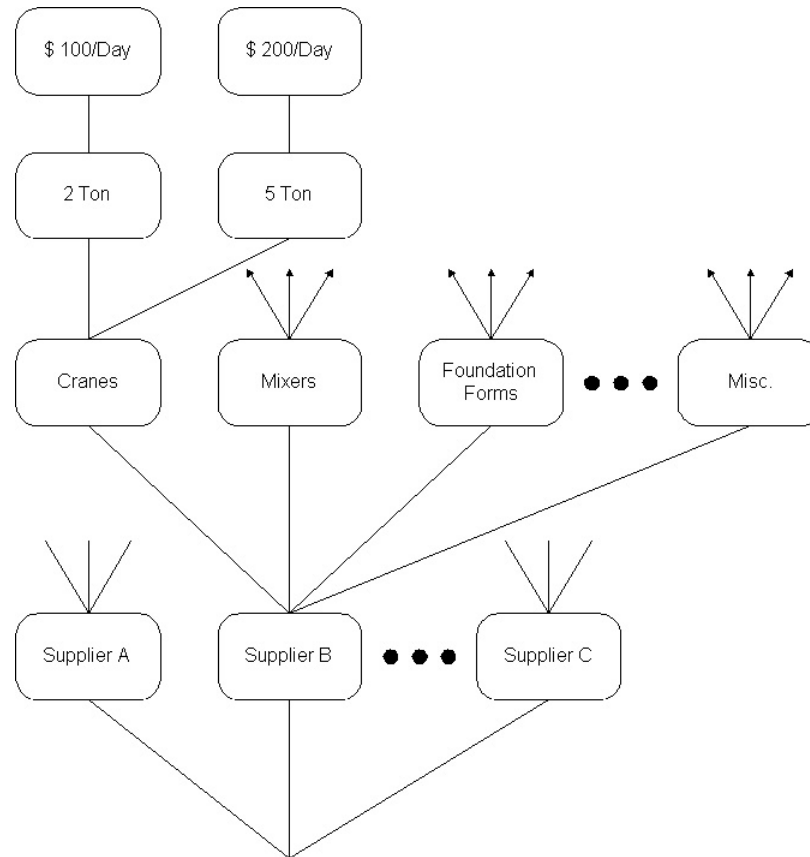

Figure 14-2 Hierarchical Data Organization

The network model or database organization retains the organization of information on branches and nodes, but does not require a tree of structure such as the one in Figure 14-2. [9] This gives greater flexibility but does not necessarily provide ease of access to all data items. For example, Figure 14-3 shows a portion of a network model database for a building. The structural member shown in the figure is related to four adjoining members, data on the joints designed for each end, an assembly related to a room, and an aggregation for similar members to record member specifications.

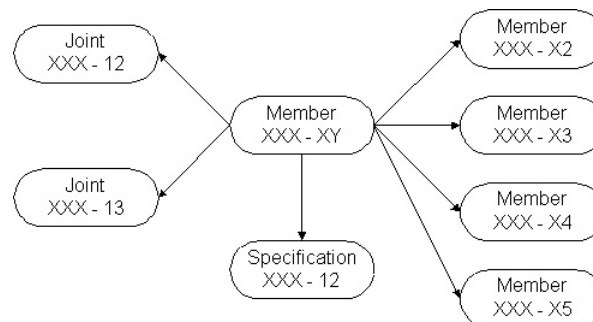

Figure 14-3 Example of a Network Data Model

While the early, large databases were based on the hierarchical or network organizations, the relational model is now preferred in many applications due to its flexibility and conceptual simplicity. Relational databases form the kernel for large systems such as ORACLE or SAP. However, databases distributed among numerous servers may have a

network structure (as in Figure 14-3), with full relational databases contained at one or more nodes. Similarly, "data warehouse" organizations may contain several different types of databases and information files. For these data warehouses, more complicated search approaches are essential, such as automatic indexing of multi-media files such as photographs.

More recently, some new forms of organized databases have appeared, spurred in part by work in artificial intelligence. For example, Figure 14-4 illustrates a *frame* data structure used to represent a building design element. This frame describes the location, type, cost, material, scheduled work time, etc. for a particular concrete footing. A frame is a general purpose data representation scheme in which information is arranged in *slots* within a named frame. Slots may contain lists, values, text, procedural statements (such as calculation rules), pointers or other entities. Frames can be inter-connected so that information may be *inherited* between slots. Figure 14-5 illustrates a set of inter-connected frames used to describe a building design and construction plan. [10] *Object oriented* data representation is similar in that very flexible local arrangements of data are permitted. While these types of data storage organizations are active areas of research, commercial database systems based on these organizations are not yet available.

<i>SLOT</i>	<i>VALUE</i>	<i>UNITS</i>
Part-of	Foundation	---
Is-a	DE	---
Name	Footing	---
Name-code	60	---
Shape	Rectangular	---
Material	Concrete	---
Material-code	01	---
Multiplier	24	---
Construction-type	---	Cast-in-place
Concrete-type	4000	Psi
P steel	.....	---
Grade	.....	---
p-dead	.....	Kips
p-live	.....	Kips
Mmax-X	.....	k-in
Mmax-Y	.....	k-in
X1-dimension	3	Ft
Y1-dimension	2	Ft
Z1-dimension	14	Ft
Element-numbers	(foot-1 foot-2...)	---
X1	(.....)	---
X2	(.....)	---
Y1	(.....)	---
Y2	(.....)	---
Xg-coordinates	(10 50 ...)	Ft
Yg-coordinates	(25 34 ...)	Ft
Zg-coordinates	(20 20 ...)	Ft
Material-cost	.....	\$
Crew-cost	.....	\$
Start-time	.....	Month-day-year
Finish-time	.....	Month-date-year

Figure 14-4 Illustration of Data Stored in a Frame

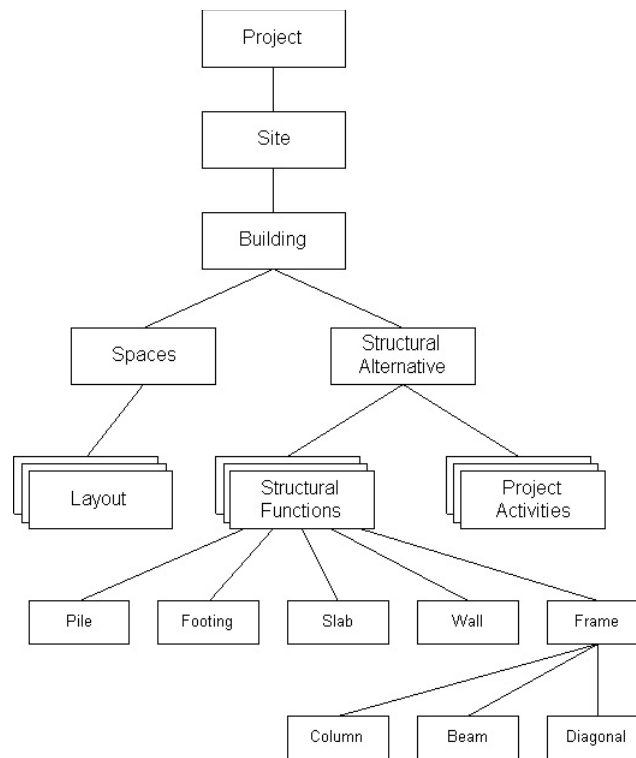

Figure 14-5 Illustration of a Frame Based Data Storage Hierarchy

[Back to top](#)

## 14.7 Centralized Database Management Systems

Whichever conceptual model or database management system is adopted, the use of a central database management system has a number of advantages and some costs compared to the commonly employed special purpose datafiles. A datafile consists of a set of records arranged and defined for a single application system. Relational information between items in a record or between records is not explicitly described or available to other application systems. For example, a file of project activity durations and scheduled times might be assembled and manipulated by a project scheduling system. This datafile would not necessarily be available to the accounting system or to corporate planners.

A centralized DBM has several advantages over such stand-alone systems: [\[11\]](#)

- **Reduced redundancy** good planning can allow duplicate or similar data stored in different files for different applications to be combined and stored only once.
- **Improved availability** information may be made available to any application program through the use of the DBM
- **Reduced inconsistency** if the same data is stored in more than one place, then updating in one place and not everywhere can lead to inconsistencies in the database.
- **Enforced data security** authorization to use information can be centralized.

For the purpose of project management, the issue of improved availability is particularly important. Most application programs create and *own* particular datafiles in the sense that information is difficult to obtain directly for other applications. Common problems in attempting to transfer data between such special purpose files are missing data items, unusable formats, and unknown formats.

As an example, suppose that the Purchasing Department keeps records of equipment rental costs on each project underway. This data is arranged so that payment of invoices can be handled expeditiously and project accounts are properly debited. The records are arranged by individual suppliers for this purpose. These records might not be particularly useful for the purpose of preparing cost estimates since:

- Some suppliers might not exist in the historical record.
- Finding the lowest cost supplier for particular pieces of equipment would be exceedingly tedious since every record would have to be read to find the desired piece of equipment and the cost.
- No direct way of abstracting the equipment codes and prices might exist.

An alternative arrangement might be to separately record equipment rental costs in (1) the Purchasing Department Records, (2) the Cost Estimating Division, and (3) the Company warehouse. While these multiple databases might each be designed for the individual use, they represent considerable redundancy and could easily result in inconsistencies as prices change over time. With a central DBM, desired views for each of these three users could be developed from a single database of equipment costs.

A manager need not conclude from this discussion that initiating a formal database will be a panacea. Life is never so simple. Installing and maintaining databases is a costly and time consuming endeavor. A single database is particularly vulnerable to equipment failure. Moreover, a central database system may be so expensive and cumbersome that it becomes ineffective; we will discuss some possibilities for transferring information between databases in a later section. But lack of good information and manual information management can also be expensive.

One might also contrast the operation of a formal, computerized database with that of a manual filing system. For the equipment supplier example cited above, an experienced purchasing clerk might be able to immediately find the lowest cost supplier of a particular piece of equipment. Making this identification might well occur in spite of the formal organization of the records by supplier organization. The experienced clerk will have his (or her) own subjective, conceptual model of the available information. This subjective model can be remarkably powerful. Unfortunately, the mass of information required, the continuing introduction of new employees, and the need for consistency on large projects make such manual systems less effective and reliable.

[Back to top](#)

## 14.8 Databases and Applications Programs

The usefulness of a database organization is particularly evident in integrated design or management environments. In these systems, numerous applications programs share a common store of information. Data is drawn from the central database as needed by individual programs. Information requests are typically performed by including pre-defined function calls to the database management system within an application program. Results from one program are stored in the database and can be used by subsequent programs without specialized translation routines. Additionally, a *user interface* usually exists by which a project manager can directly make queries to the database. Figure 14-6 illustrates the role of an integrated database in this regard as the central data store.

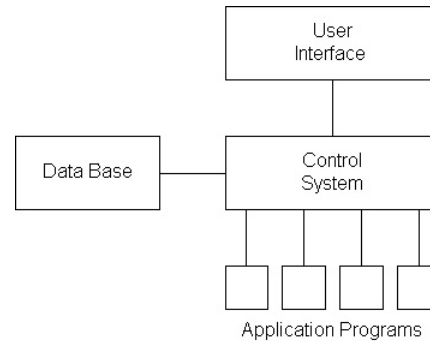

**Figure 14-6** Illustration of an Integrated Applications System

An architectural system for design can provide an example of an integrated system. [12] First, a database can serve the role of storing a library of information on standard architectural features and component properties. These standard components can be called from the database library and introduced into a new design. The database can also store the description of a new design, such as the number, type and location of individual building components. The design itself can be composed using an interactive graphics program. This program would have the capability to store a new or modified design in the database. A graphics program typically has the capability to compose numerous, two or three dimensional views of a design, to introduce shading (to represent shadows and provide greater realism to a perspective), and to allow editing (including moving, replicating, or sizing individual components). Once a design is completed and its description stored in a database, numerous analysis programs can be applied, such as:

- structural analysis,
- daylight contour programs to produce plots of available daylight in each room,
- a heat loss computation program
- area, volume and materials quantities calculations.

Production information can also be obtained from the integrated system, such as:

- dimensioned plans, sections and elevations,
- component specifications,
- construction detail specifications,
- electrical layout,
- system isometric drawings,
- bills of quantities and materials.

The advantage of an integrated system of this sort is that each program need only be designed to communicate with a single database. Accomplishing appropriate transformations of data between each pair of programs would be much more difficult. Moreover, as new applications are required, they can be added into an integrated system without extensive modifications to existing programs. For example, a library of specifications language or a program for joint design might be included in the design system described above. Similarly, a construction planning and cost estimating system might also be added.

The use of integrated systems with open access to a database is not common for construction activities at the current time. Typically, commercial systems have a closed architecture with simple datafiles or a "captive," inaccessible database management system. However, the benefits of an open architecture with an accessible database are considerable as new programs and requirements become available over time.

### Example 14-5: An Integrated System Design

As an example, Figure 14-7 illustrates the computer aided engineering (CAE) system envisioned for the knowledge and information-intensive construction industry of the future. [13] In this system, comprehensive engineering and "business" databases support different functions throughout the life time of a project. The construction phase itself includes overlapping design and construction functions. During this construction phase, computer aided design (CAD) and computer aided manufacturing (CAM) aids are available to the project manager. Databases recording the "as-built" geometry and specifications of a facility as well as the subsequent history can be particularly useful during the use and maintenance life cycle phase of the facility. As changes or repairs are needed, plans for the facility can be accessed from the database.

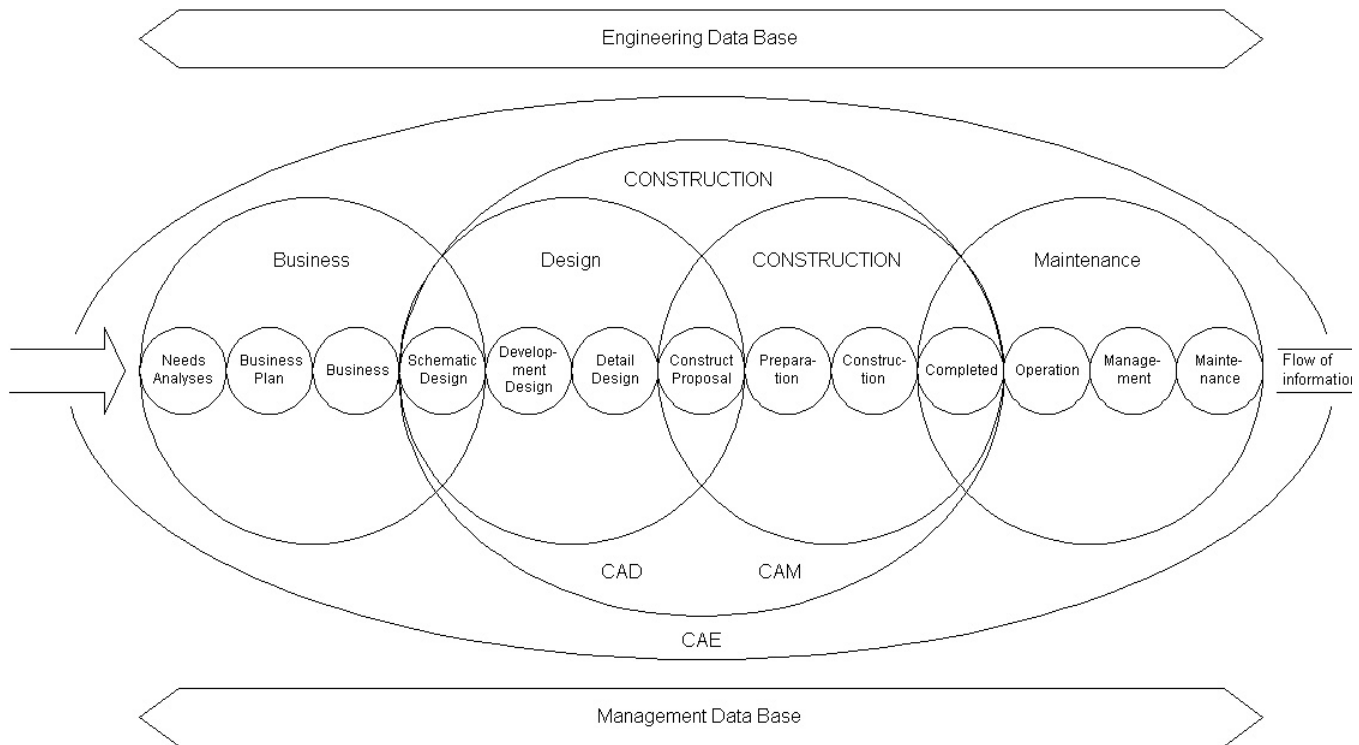

**Figure 14-7** Computer Aided Engineering in the Construction Industry  
(Reprinted with permission from Y. Ohaski and M. Mukimo, "Computer-Aided Engineering in the Construction Industry," *Engineering with Computers*, Vol. 1, no. 2, 1985.)

[Back to top](#)

## 14.9 Information Transfer and Flow

The previous sections outlined the characteristics of a computerized database. In an overabundance of optimism or enthusiasm, it might be tempting to conclude that all information pertaining to a project might be stored in a single database. This has never been achieved and is both unlikely to occur and undesirable in itself. Among the difficulties of such excessive centralization are:

- **Existence of multiple firms or agencies involved in any project.** Each organization must retain its own records of activities, whether or not other information is centralized. Geographic dispersion of work even within the same firm can also be advantageous. With design offices around the globe, fast track projects can have work underway by different offices 24 hours a day.
- **Advantages of distributed processing.** Current computer technology suggests that using a number of computers at the various points that work is performed is more cost effective than using a single, centralized mainframe computer. Personal computers not only have cost and access advantages, they also provide a degree of desired redundancy and increased reliability.
- **Dynamic changes in information needs.** As a project evolves, the level of detail and the types of information required will vary greatly.
- **Database diseconomies of scale.** As any database gets larger, it becomes less and less efficient to find desired information.
- **Incompatible user perspectives.** Defining a single data organization involves trade-offs between different groups of users and application systems. A good organization for one group may be poor for another.

In addition to these problems, there will always be a set of untidy information which cannot be easily defined or formalized to the extent necessary for storage in a database.

While a single database may be undesirable, it is also apparent that it is desirable to structure independent application systems or databases so that measurement information need only be manually recorded once and communication between the database might exist. Consider the following examples illustrating the desirability of communication between independent application systems or databases. While some progress has occurred, the level of integration and existing mechanisms for information flow in project management is fairly primitive. By and large, information flow relies primarily on talking, written texts of reports and specifications and drawings.

### Example 14-6: Time Cards

Time card information of labor is used to determine the amount which employees are to be paid and to provide records of work performed by activity. In many firms, the system of payroll accounts and the database of project management accounts (i.e., expenditure by activity) are maintained independently. As a result, the information available from time cards is often recorded twice in mutually incompatible formats. This repetition increases costs and the possibility of transcription errors. The use of a preprocessor system to check for errors and inconsistencies and to format the information from each card for the various systems involved is likely to be a significant improvement (Figure 14-8). Alternatively, a communications facility between two databases of payroll and project management accounts might be developed.



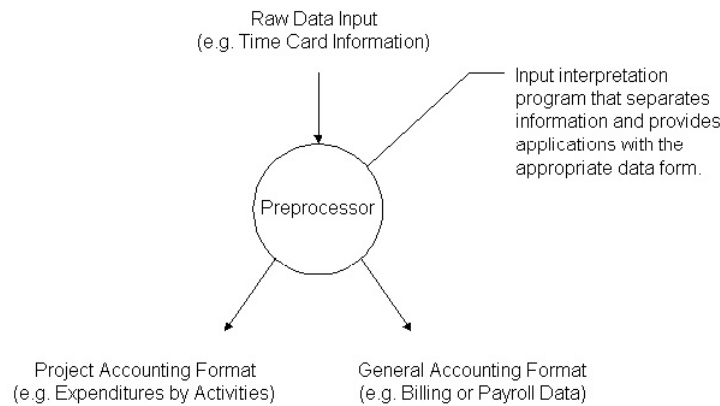

**Figure 14-8** Application of an Input Pre-processor

#### Example 14-7: Final Cost Estimation, Scheduling and Monitoring

Many firms maintain essentially independent systems for final cost estimation and project activity scheduling and monitoring. As a result, the detailed breakdown of the project into specific job related activities must be completely re-done for scheduling and monitoring. By providing a means of *rolling-over* or transferring the final cost estimate, some of this expensive and time-consuming planning effort could be avoided.

#### Example 14-8: Design Representation

In many areas of engineering design, the use of computer analysis tools applied to facility models has become prevalent and remarkably effective. However, these computer-based facility models are often separately developed or encoded by each firm involved in the design process. Thus, the architect, structural engineer, mechanical engineer, steel fabricator, construction manager and others might all have separate computer-based representations of a facility. Communication by means of reproduced facility plans and prose specifications is traditional among these groups. While transfer of this information in a form suitable for direct computer processing is difficult, it offers obvious advantages in avoiding repetition of work, delays and transcription errors. A de facto standard for transfer of geometric information emerged with the dominance of the AUTOCAD design system in the A/E/C industry. Information transfer was accomplished by copying AUTOCAD files from user to user, including uses on construction sites to visualize the design. More flexible and extensive standards for design information transfer also exist, such as the Industry Foundation Classes (IFC) standard developed by the International Alliance for Interoperability (See [http://www.iai-international.org/iai\\_international/](http://www.iai-international.org/iai_international/)) and the "Fully Integrated and Automated Project Processes" developed by FIATECH (see <http://www.fiatech.org/>)

[Back to top](#)

## 14.10 References

1. Au, T., C. Hendrickson and A. Pasquale, "Introduction of a Relational Database Within a Cost Estimating System," *Transportation Research Record* 1050, pp. 57-62, 1986.
2. Bosserman, B.E. and M.E. Ford, "Development of Computerized Specifications," *ASCE Journal of Construction Engineering and Management*, Vol. 110, No. CO3, 1984, pp. 375-384.
3. Date, C.J., *An Introduction to Database Systems*, 3rd Ed., Addison-Wesley, 1981.
4. Kim, W., "Relational Database Systems," *ACM Computing Surveys*, Vol. 11, No. 3, 1979, pp. 185-211.
5. Mitchell, William J., *Computer Aided Architectural Design*, Van Nostrand Reinhold Co., New York, 1977.
6. Viecelli, A.M., "Communication and Coding of Computerized Construction Project Information," Unpublished MS Thesis, Department of Civil Engineering, Carnegie Mellon University, Pittsburgh, PA, 1984.
7. Wilkinson, R.W., "Computerized Specifications on a Small Project," *ASCE Journal of Construction Engineering and Management*, Vol. 110, No. CO3, 1984, PP. 337-345.
8. Latimer, Dewitt and Chris Hendrickson, "Digital Archival of Construction Project Information," Proceedings of the International Symposium on Automation and Robotics for Construction, 2002."

[Back to top](#)

## 14.11 Problems

1. Suppose we wish to develop a database consisting of contractor names, addresses and particular specialties as in Table 14-3.
  - o Suggest two *hierarchical* organizations of this data.
  - o Suggest an alternative *relational* organization for this data.
  - o Which organization would you recommend for implementation of a database?
2. Suggest four reports which could be obtained from the warehouse inventory system described in Section 14.3 and describe what each report might be used for and by whom.
3. Suppose that a general contractor wished to keep a historical database of the results of bid competitions. Suggest (a) the information that might be stored, and (b) a possible organization of this information.
4. For your suggested database from Problem 3, implement a prototype system on a spreadsheet software program.
5. Describe a relational database that would be useful in storing the beginning, ending and all intermediate stages for blockworld robot movements as described in Problem 6 in Chapter 9.
6. Describe a relational database that would be appropriate for maintaining activity scheduling information during project monitoring. Be explicit about what relations would be defined, the attributes in each relation, and allowable ranges of values.

[Back to top](#)

## 14.12 Footnotes

1. See D.F. Rogge, "Delay Reporting Within Cost Accounting System," *ASCE Journal of Construction Engineering and Management*, Vol. 110, No. 2, 1984, pp. 289-292.

[Back](#)

2. The system is based loosely upon a successful construction yard management system originally for Mellon-Stuart Company, Pittsburgh, PA. in 1983. The authors are indebted to A. Pasquale for providing the information and operating experience of the system. [Back](#)
3. Attributed to R. Lemons in J. Bentley "Programming Pearls," *Communications of the ACM*, Vol. 28, No. 9, 1985, pp. 896-899. [Back](#)
4. See Wilkinson, R.W. "Computerized Specifications on a Small Project," *ASCE Journal of Construction Engineering and Management*, Vol. 110, No. CO3, 1984, pp. 337-345. [Back](#)
5. See C.J. Date, *An Introduction to Database Systems*, 3rd ed., Addison-Wesley Publishing Company, Reading, MA, 1981. [Back](#)
6. This is one example of a normalization in relational databases. For more formal discussions of the *normalizations* of relational databases and the explicit algebra which can be used on such relations, see Date op cit. [Back](#)
7. For a discussion of relational algebra, see E.F. Codd, "Relational Completeness of Data Base Sublanguages," *Courant Computer Science Symposia Series*, Vol. 6, Prentice-Hall, 1972. [Back](#)
8. See D.C. Trichritzis and F.H. Lochovsky, "Hierarchical Data-Base Management," *ACM Computing Surveys* Vol. 8, No. 1, 1976, pp. 105-123. [Back](#)
9. For a more extensive comparison, see A.S. Michaels, B. Mittman, and C.R. Carlson, "A Comparison of Relational and CODASYL Approaches to Data-Base Management," *ACM Computing Surveys*, Vol. 8, No. 1, 1976, pp. 125-157. [Back](#)
10. This organization is used for the central data store in an integrated building design environment. See Fenves, S., U. Flemming, C. Hendrickson, M. Maher, and G. Schmitt, "An Integrated Software Environment for Building Design and Construction," *Proc. of the Fifth ASCE Conference on Computing in Civil Engineering*, 1987 [Back](#)
11. For a discussion, see D.R. Rehak and L.A. Lopez, *Computer Aided Engineering Problems and Prospects*, Civil Engr. Systems Lab., Univ. of Illinois, Urbana, IL, 1981. [Back](#)
12. See W.J. Mitchell, *Computer-Aided Architectural Design*, Van Nostrand Reinhold Co., New York, 1977. [Back](#)
13. This figure was adapted from Y. Ohsaki and M. Mikumo, "Computer-aided Engineering in the Construction Industry," *Engineering with Computers*, vol. 1, no. 2, 1985, pp. 87-102. [Back](#)

[Previous Chapter](#) | [Table of Contents](#)