

MOUSEY THE JUNKBOT

By Gareth Branwyn



With a few spare parts, you can turn an old computer mouse into an amusing little robot. >>

Set up: p.99 Make it: p.100 Use it: p.109

THE FINE ART OF MAKING “FRANKENMICE”

This project turns an analog computer mouse into a robot that'll delight friends and wow workmates down on the cube farm. Mousey's behavior is fittingly mouse-like. It scoots quickly across the floor, thanks to lively little motors. And when the critter crashes into anything, it speeds off in the opposite direction.

The robot's "brains" are an ingenious hack based on an audio operational amplifier (op-amp), an 8-pin chip that's normally used to drive answering machine speakers and other lo-fi equipment. Following Randy Sargent's pioneering design (see page 102), Mousey repurposes this chip to boost light-sensor input to motor-powerable levels. The result is simple, fast-reacting analog circuitry that fits inside a mouse case.

Gareth Branwyn writes about the intersection of technology and culture for *Wired* and other publications, and is a member of MAKE's Advisory Board. He is also "Cyborg-in-Chief" of *Streettech.com*.

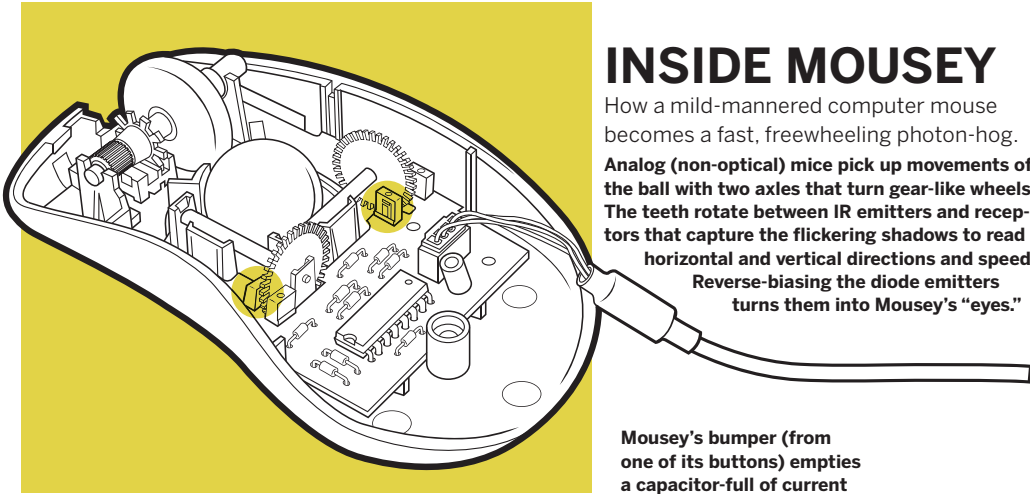

INSIDE MOUSEY

How a mild-mannered computer mouse becomes a fast, freewheeling photon-hog.

Analog (non-optical) mice pick up movements of the ball with two axes that turn gear-like wheels. The teeth rotate between IR emitters and receptors that capture the flickering shadows to read horizontal and vertical directions and speeds. Reverse-biasing the diode emitters turns them into Mousey's "eyes."

Mousey's bumper (from one of its buttons) empties a capacitor-full of current across a relay, temporarily crossing the motors' voltages and throwing Mousey into reverse.

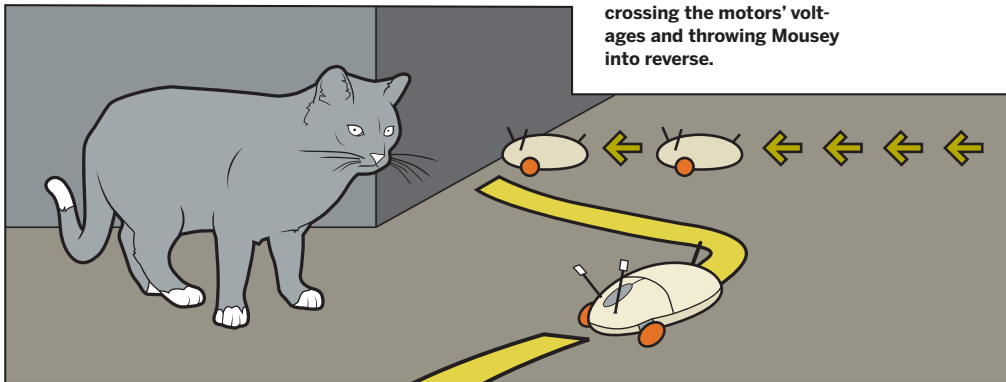

Randy Sargent's Herbie (below) was the first LM386-based bot. It finished last in the 1996 Robothon's line-following race, but went on to spawn many descendent designs.

The eyes' light difference is amplified and tapped into the circuit between the two motors, wired in series. As one motor draws less power, the other uses more, steering the bot.

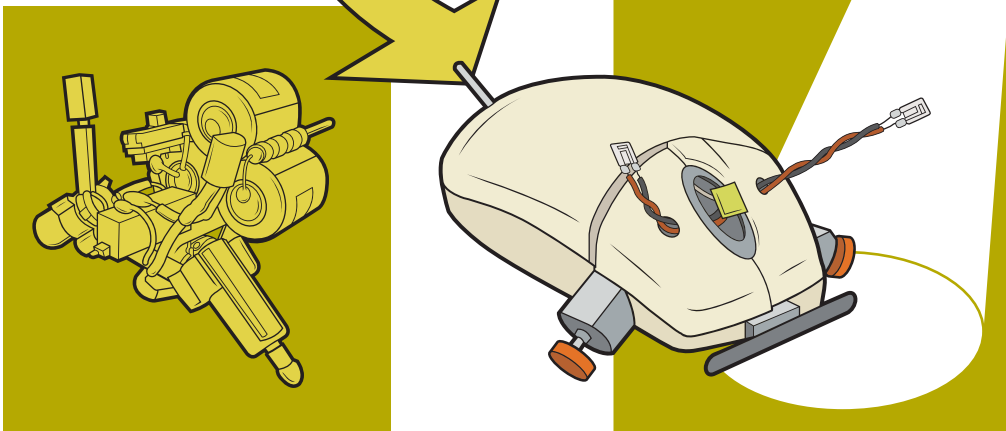

SET UP.

Visit makezine.com/02/mousebot for source list.

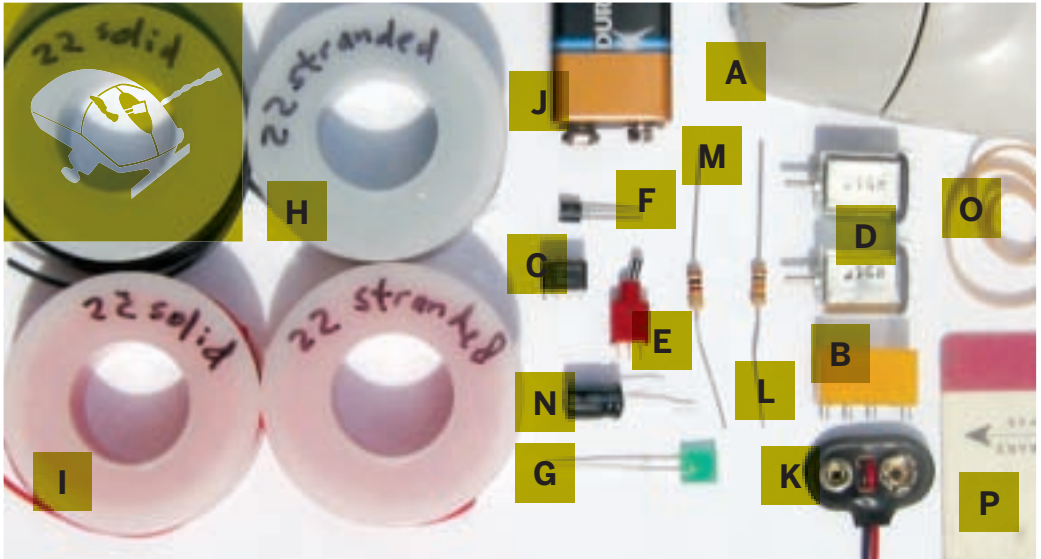

First, you'll need an analog (non-optical) mouse to cannibalize for its case and several parts inside. If you don't have an old mouse or two gathering dust, ask friends and colleagues. Otherwise, you can buy a new, super-cheap model such as the Kensington ValueMouse, which costs \$10 and has enough space to fit all of your components inside. The bigger and more symmetrical the mouse, the easier the build will be. "Handed" mice with asymmetrical, curved bodies present problems.

MATERIALS:

Mouse case [A]

2 Light sensors
From mouse

SPST touch switch
From mouse

Double-pole, double-throw (DPDT) 5-volt relay [B]
From analog modem, or Solarbotics #RE1

LM386 audio operational amplifier (op-amp) [C]
From answering machine, speakerphone, intercom, etc., or Solarbotics #LM386

2 Small 4.5 VDC motors [D] From motorized toys, or Solarbotics #RM1A / Mabu-chi FF-030-PN

SPST toggle switch [E]
Solarbotics #SWT2

2N3904 or PN2222 NPN-type transistor [F]
Solarbotics #TR3904/TR2222

Light-emitting diode (LED) [G]

2 Spools of 22 to 24-gauge stranded hook-up wire [H]
Ideally, 1 black and 1 red

4 Pieces of 22-gauge, solid-core hook-up wire [I]
Ideally, 2 red and 2 black, 6½" long

9V battery [J]

9V battery snap [K]

1kΩ to 20kΩ resistor [L]

1kΩ resistor [M]

10μF to 100μF electrolytic capacitor [N]

Rubber band or other tire-making material [O]

Small piece of plastic [P]
At least ¼" x 2½" of hard, springy, thin plastic, like .030" Plasticard stock, or an old credit card

Piece of Velcro or two-way tape (optional)

TOOLS:

Phillips screwdriver
For disassembling mouse

Dremel tool
With bits and cutting discs

1kΩ to 20kΩ resistor [L]

Needlenose pliers

Digital multimeter (DMM)

X-ACTO/hobby knife

Soldering iron

Solder sucker or desoldering bulb

Wire cutters/wire snips

Breadboard, hook-up wire

Superglue, epoxy, or other contact cement

Poster putty, electrical tape, cellophane tape

Ruler

Protective goggles, mask

MAKE IT.**BUILD YOUR
ROBOT MOUSE****START** >>>**Time: A Day Complexity: Medium****1. MOUSEY'S CIRCUITRY IS FREEFORMED**

This means that we'll solder the parts to each other without a circuit board, building everything up right inside the mouse case. But before we do this, we'll need to prep the case and install the motors, and then breadboard the circuitry separately to make sure everything works.

Before unholstering your Dremel tool, you'll need to determine if the mouse has enough space inside. Unscrew the mouse case and eyeball it to make sure that it will hold the two DC motors and a 9-volt battery. Screws may be hiding under little nylon feet or tape strips on the bottom of the mouse. Save these bits so you can put them back at the end of the build; they'll help reduce friction.

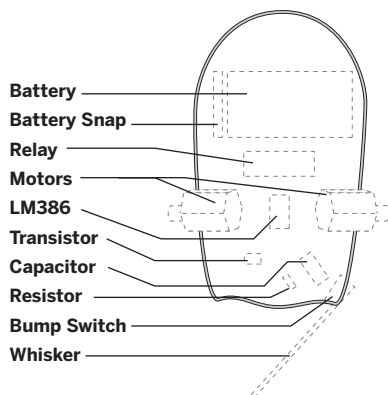
**Mouse case and parts that need to fit inside.****Cleared-out mouse case.****2. PERFORM AN ALIEN MOUSE AUTOPSY**

Once you have a suitable candidate, remove all of the mechanics and electronics. Unhook the mouse cable from its plug-type connector, pop out the scroll wheel (if it has one), and then pry out the PCB (printed circuit board). Set these parts aside. Then use your Dremel and cut-off wheel to hollow out the case, removing all of the plastic mounts and partitions inside, except for any screw post(s) that hold the case together. Do the same for the top half, although you may want to leave the mounts that hold the buttons in place.

Note: Plastic dust is nasty stuff, so work on newspaper and wear goggles and a mask.

3. ADD THE POWER SWITCH

The last piece of preparatory bodywork is adding the power switch, a large toggle placed rear topside so it looks like a tail. Find an appropriate mouse-tail location, then drill a hole in the case big enough for the switch. If the switch has a threaded bushing and two nuts, take one nut off, insert the bushing up through the hole, and then tighten the nut back down onto the outside of the case. In some cases, a plastic screw post interferes with the tail area. If so, you can cut out the post and reconnect the top and bottom halves with tape or glue.

**The top of our mouse case with its toggle "tail" installed.**

4. MOTOR AND BATTERY PLACEMENT

Now we're ready to figure out the arrangement of the bigger components and cut openings for the motors. Mouse shapes vary, so you'll use some judgment here, but the two motors should be oriented perpendicular to the centerline of the body, so the bot travels in a straight line. Also be sure to leave enough space behind the motors for the battery.

Once you've placed the motors and battery, you're ready to cut openings for the axles and wheels, which are simply the drive shafts and gears of the motors.

You'll want to angle the shafts coming out of the mouse body so they support the bot and set a proper speed. The steeper the angle, the less rubber will meet the road, which slows the bot down – but this is good, since many builders have complained that Mousey moves too fast. If you're using the lively Solarbotics RM1 motors, 60 degrees is about right, as shown.

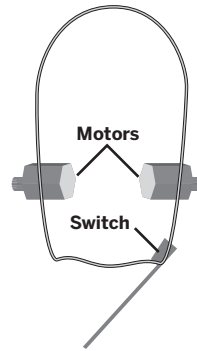

Eventual whisker

Motor placement, angle, and switch placement are very important for making Mousey work properly.

Use poster putty to hold the motors in place temporarily. Then get down at eye level and make sure the gear "wheels" are making good, level contact with the table. Once the motors are positioned properly, glue them in place.

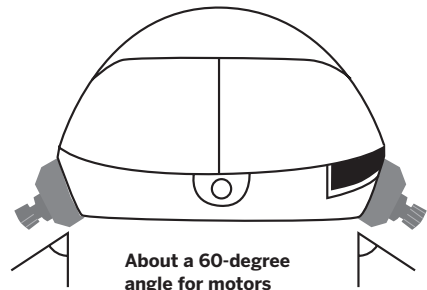

5. MAKE THE BUMP SWITCH AND TIRES

Your mousebot will have a giant "whisker" – a bump switch (courtesy of one of the mouse's button switches) that triggers Mousey's scuttle-away behavior. Look on the mouse PCB (see photo in Step 7) for a tiny plastic box that clicks when

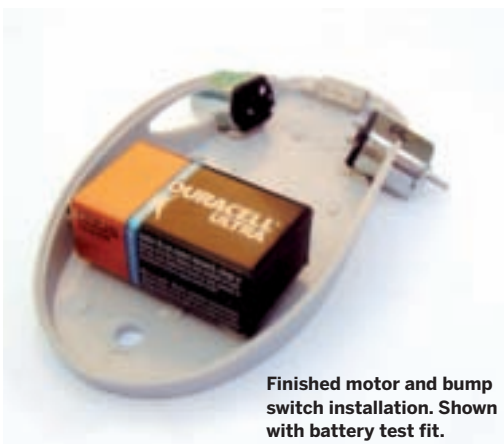

you press it down; then desolder it. Once you have the switch removed, attach the base with putty to one side of your mouse's front end. Tape the strip of hard plastic in place, so that it covers the tiny switch button and runs along the front of the mouse like a wide bumper. The idea is to have the switch triggered by a bump anywhere along the length of the "whisker," so when you press in the plastic, you should hear an itty-bitty click. Tweak this arrangement until it looks good. Once you have your placement, drill a small opening in the mouse case bottom for the switch to stick out. Also cut the plastic strip down to size, about $\frac{1}{4}$ " x $2\frac{1}{2}$ ".

The last mechanical modification needed for the bottom half is adding tires. Find a rubber band with the same width as the sprockets on the drive shafts, and then cut it to length, wrap it around, and glue it on. You can make the wheels thicker by continuing to wrap the band around itself. Rubber or plastic tubing also makes good tires, as does corrugated tubing from a Lego Mindstorms robot kit or the rubber cylinders from Dremel drum sander bits.

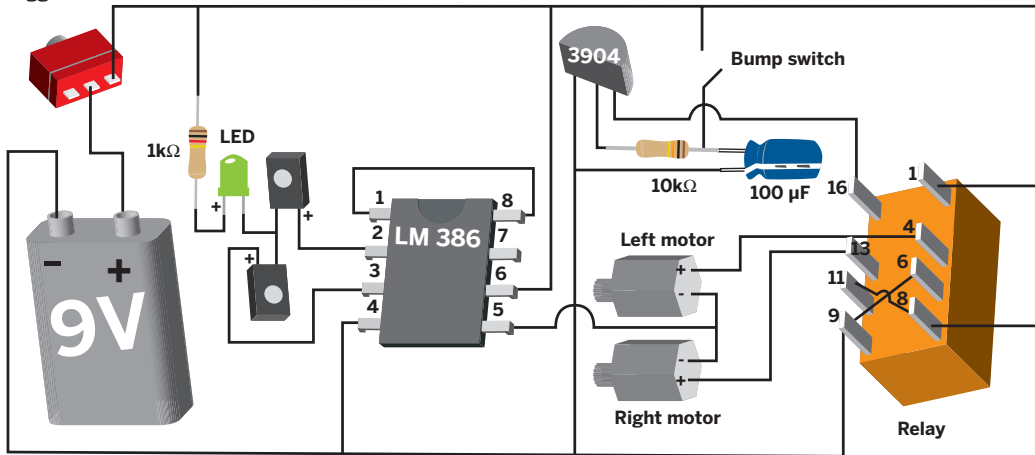
Toggle Switch

6. UNDERSTAND MOUSEY'S BRAIN The LM386 op-amp, the main component of Mousey's control circuit, "listens" to two input signals. If one signal is lower than the other, the chip boosts that signal to equalize the one output. In our case, the inputs are light values rather than audio. If we hook this output to two DC motors, we have a little brain that reads input from two light sensors, compares them, and boosts the power on the dimmer side. This creates a robot that follows a light source, auto-correcting itself as it moves.

The bump switch triggers a relay that reverses the two motors' inputs for a few seconds. This makes Mousey scuttle away from light after any collision, adding to its lifelike behavior. The diagram above shows the circuit diagram for Mousey's brain.

Use this diagram as a reference as you build your mousebot.

A larger version of this image can be found at
<http://xrl.us/fkxi>.

BEAM ROBOTICS: SURVIVAL OF THE FUNNEST

Mousey comes out of the BEAM design tradition, a biology-inspired doctrine which frowns on microprocessors in favor of simple analog control, in order to create robots that act and react with the physical world directly, perhaps instinctively.

BEAM's natural selection process occurs at conventions and gatherings like Robothon, where bots compete against one another in races, "sumo" matches, high jumps, rope climbs, and other Olympics-style events.

Through BEAM's 14 years of evolution, BEAMers worldwide have designed and refined numerous species of inexpensive and easy-to-build robo-critters, including photovores such as Mousey, four- and six-legged walkers, sun-powered solarrollers, and swimming aquavores.

Mousey's circuitry is based on Randy Sargent's line-follower bot Herbie, which competed in the Seattle Robothon in 1996. Many variations of the design followed,

including Dave Hrynkiw's Herbie Photovore. Following Dave's example, we built ours with as much techno-junk as possible, including an old computer mouse and a 5-volt double-pole, double-throw (DPDT) relay – a component found inside most analog modems.

BEAM Resources

The acronym BEAM stands for "Biology, Electronics, Aesthetics, and Mechanics" and was coined by Mark Tilden.

Solarbotics: The main BEAM portal Solarbotics.net

Yahoo! Groups: BEAM Robotics
groups.yahoo.com/group/beam

Robothon: Seattle, Oct. 8-9, 2005
robothon.com

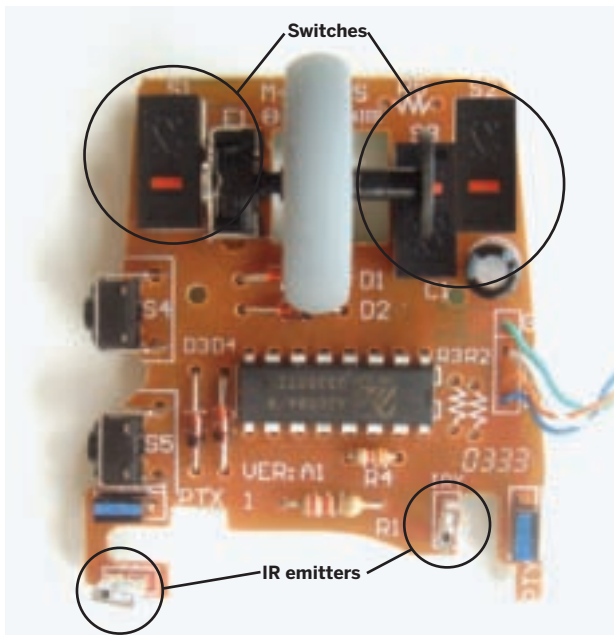

A pair of IR emitters will serve as your robot's eyes. Note their likely location on the mouse's PCB.

7. CREATE MOUSEY'S EYES

For Mousey's eyes, we can use the mouse's own two IR emitters, a.k.a. phototransistors. During normal computer mousing, these shine infrared through the mouse's perforated encoder wheels, which is then received by photodetectors on the other side.

Like many fundamental devices, these emitters can work as both transmitters and receivers. As receivers, they're more robust and less specialized than the mouse's dedicated internal photoreceivers, and this makes them a better choice for Mousey's eyes to the outside world. On most mice, the emitters are clear plastic boxes with a tiny dome protruding from one face, while the detectors are solid black.

Find the clear emitters and desolder them from the PCB. You are now the proud owner of a pair of robot eyeballs.

8. GIVE MOUSEY EYESTALKS

Our IR emitters only have two stubby little pins coming out. We need to give Mousey some optic nerves – eyestalks that jut from the front of its body. These not only look cool, but also allow you to adjust Mousey's sensitivity to light by bending the stalks around.

First we need to determine which pin on each emitter is positive and which is negative. Set your digital multimeter to Diode Check mode, and touch the probes to each pin. If the read-out is "OL" (no connection), reverse the probes. When connected correctly, you should get a reading of about 1V, with the red probe indicating the anode (or positive) pin. If your DMM doesn't have Diode Check, look for a positive voltage of about 0.6V when the red probe is on the anode.

To create the stalks, cut four 6½" pieces of 22-gauge, solid-core hook-up wire. If you have red and black, cut two of each color. Solid core is better than stranded in this case, because it makes stiffer stalks



Our finished eyestalks, ready to shed some light on our control circuit.

that hold their shape when you mold them.

Solder the red wire to the cathode (-) pins on the emitters and the black wires to the anode (+) pins. The colors are switched because we're reverse-biasing the diodes; with current flowing in the normal direction, additional electrons excited by light in the diode's junction get lost in the flow, but with current trickling the opposite way, the difference is more noticeable, making the circuit more sensitive. When the wires are soldered in place, twist them together and strip some of the jacket off of the other ends.

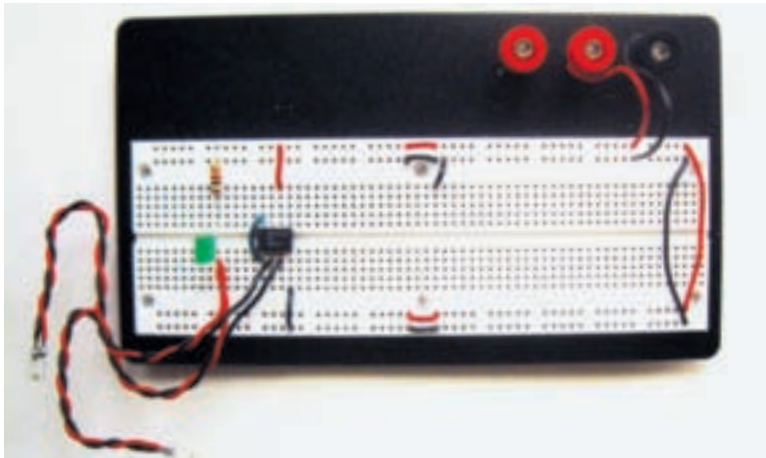

The first part of Mousey's brain: sensors and main control circuit.

9. HOOK UP THE OP-AMP

With all of your electronic components in hand, we're ready to breadboard. Here are the steps to install the op-amp chip and main control circuit:

9a. Install the LM386 chip across the trench on your breadboard. With all ICs, pins are numbered counter-clockwise around, starting at the little dimple.

9b. Connect tie-points for Pins 1 and 8 together with a piece of hook-up wire. These two pins control the op-amp's gain; by connecting them with a jumper, we're increasing the circuit's sensitivity to the input.

9c. Connect the eyestalks by taking the black wires from each and connecting them to tie points for Pins 2 and 3 (the op-amp's inputs). Connect the red wires together by plugging them into a node about

five or six rows left of the chip. Our horizontally oriented board is organized with +/- power supply at top/bottom and all chips facing left. Translate accordingly for different breadboard layouts.

9d. Plug the negative lead of an LED (the shorter end) into the node with the two red eyestalk wires, and the positive lead into a new node on the opposite side of the trench. Then take a 1k-ohm resistor and plug one end into the LED's positive node, and the other end into the positive/upper power bus. These components constitute a sensitivity-boosting subcircuit originally developed by Wilf Rigter.

9e. Finish this part of your circuit by connecting the power pin of the LM386 (Pin 6) to the positive power bus, and the ground (Pin 4) to the lower/negative bus. We'll connect the battery later.

10. CREATE THE RUNAWAY CIRCUIT

If we hooked up Mousey's motors and battery at this point, it would simply chase a light source. Now we'll make it more interesting by adding Mousey's whisker-triggered "fear" reflex. To create the runaway circuit, we need the bump switch you already pulled, a 5V DPDT relay, a transistor, and a simple timer consisting of a capacitor and a resistor. When the switch is triggered, the transistor enables the runaway circuit, where the capacitor powers Mousey's motors in reverse. When the capacitor has fully discharged a few seconds later, the transistor switches motor control back to the regular, light-following circuit.

The resistance and capacitance determine the rate and amount of current discharged, and you can play with different resistor and cap values until you find the runaway behavior you want. Try resistors in the 1k- to 20k-ohm range, and capacitors in the 10- to 100-microfarad range. With both, the higher the value, the longer the discharge time. We used a 10k-ohm resistor and a 100-microfarad capacitor, which gave about 8 seconds of fast backing up. Here are the steps for breadboarding the runaway circuit:

10a. The relay's pins are spaced apart widely, so we'll refer to pins by their breadboard locations. Plug in the relay about six nodes to the right of the LM386, or 1-16 (although the relay actually has only eight pins).

10b. Cross a wire from Pin 8 to Pin 11 and another from Pin 6 to Pin 9. These two wires will reverse the motor connections when the relay is engaged.

10c. Plug the capacitor's positive lead into an unused row just left of the relay, and the cathode to the negative power bus. On electrolytic caps, the cathode is usually marked with a stripe or (-) symbol.

10d. Plug in one end of the higher-ohm resistor to connect with the capacitor anode, and jump the other end over the trench to a new node on the other side.

10e. Spread the transistor's pins and plug it in with the flat side facing the trench, above the relay, such that the center pin (base) connects to the resistor lead, the left pin (emitter) is in an unused node, and the right pin (collector) connects to Pin 16 of the relay.

10f. Plug one hook-up wire into the bottom resistor and capacitor node, somewhere between the two, and a second wire up to the positive power bus. Bend the tips of the wires so they can touch, but keep them separated. These wires will act as the

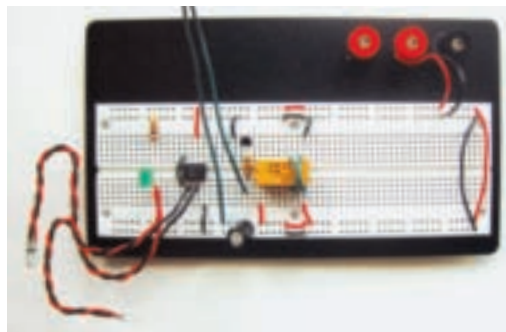

Our breadboard with control chip, timer, and relay circuits installed.

bump switch when you touch them together. We're being lazy and assuming that the switch works, but you can hook the wires up to it to make sure.

10g. Run two wires to connect Pin 1 and Pin 8 on the relay with the top/positive power bus. Connect Pin 9 to the negative bus. Finally, connect the transistor's left pin (emitter) to the bottom/negative bus. This connects the relay and transistor to power. That's it — look over your cool robot brain!

11. CONNECT THE MOTORS AND POWER

Now we're ready to connect the motors and power and see if it all works. Take the right motor and connect its negative terminal to Pin 5 of the LM386 chip and its positive terminal to Pin 13 on the relay. Take the left motor and connect its negative to Pin 5 of the chip, and positive to Pin 4 on the relay. On many motors, the positive terminal is marked with a dimple or a (+) symbol.

Finally, connect the 9V battery to the board via a battery snap or clips, recalling that the battery's "outie" snap is its negative pole. Your breadboard should look like the image at right, and the motors should run. If so, congratulations! Get yourself a flashlight and start having fun moving the beam around Mousey's light sensors, noticing the speed changes. Then touch the switch wires together, hear the relay click, and see the motors reverse their direction.

If all did not go well, check that everything's where it should be, with the capacitor, resistors, and transistor in the proper holes and power running in the right direction. Some breadboards split their power

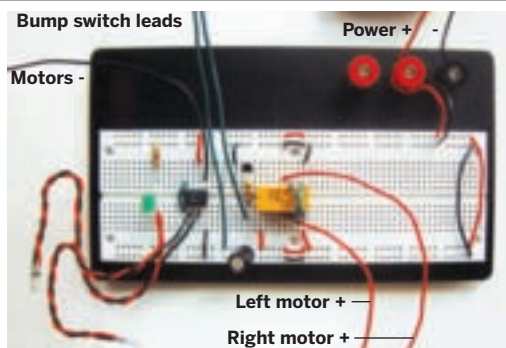

Finished breadboard circuit with motors and power attached.

busses into multiple segments; in this case, you need to connect the battery to each occupied segment of the power bus, or else wire them together. Use a fresh battery, and probe around with the multimeter to make sure that the right amount of power is getting where it should. If the eyes don't work, check the eyeball solder joins, and if necessary, swap the eyeballs out for another set from another old mouse. Some definitely work better than others.

12. FREEFORM MOUSEY'S CONTROL CIRCUIT

Now that we have a light-hungry robot brain, we need to install it in our mouse body so that it can feed (cue *Night of the Living Dead* sound effects here). In general, we'll want to use a lighter wire, such as stranded 22-gauge, to tuck into the case and put less stress on the solder joints.

Before soldering, test fit all the parts inside your case, starting with the battery, motors, and bump switch. Then position the other components around these. The resistor/LED sensitivity-booster circuit will fit against the top half. As you arrange, check that the case still closes, and leave some headroom for the wires. When you're happy with your arrangement, empty the case and install the battery using two-way tape, Velcro tape, or poster putty. That way, you can replace it when Mousey gets that run-down feeling.

13. INSTALL THE RELAY

To prepare the relay for installation, put it in "dead bug mode" (on its back), and solder short lengths of solid-core wire to the bottom four pins (the switch pins) in an X configuration, as shown.

13a. Solder the transistor's collector (the right pin when you're looking at the flat side with the pins pointing down) to the top-left coil pin on the relay, Pin 16 on the breadboard. Solder a 4" piece of black wire (denoting negative) to the transistor's emitter. This will connect to Pin 4 of the IC and negative power.

13b. Solder a short red wire connecting the top and bottom pins on the relay's right side, Pins 1 and 8. Solder a 2" black (negative) wire onto the bottom-left pin, Pin 9, and then a 3" red wire onto the bottom-right, Pin 8.

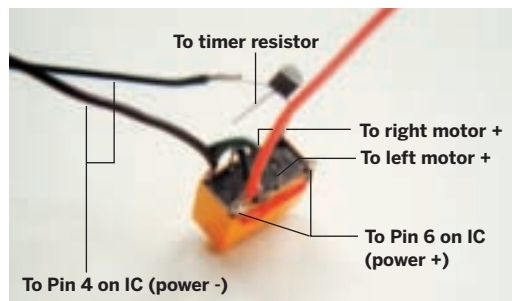

13c. Glue the relay into the case, in dead bug mode, and allow it to dry before soldering anything else to it. We glued ours between the motors.

13d. Using red wire, solder the left motor's positive terminal to the second pin down on the right side (Pin 4 on the breadboard), and solder the right motor's positive to the opposite pin on the relay, Pin 13.

14. CONNECT THE SWITCH COMPONENTS

With the relay close to the front, we can chain together the timer resistor, capacitor, and bump switch without needing additional wires. As with the relay, we'll attach components "out of body" first, for easier soldering.

14a. Solder a 4" black wire to the capacitor's negative lead (which should be marked).

14b. Using a multimeter on your 3-pin bump switch, determine which side pin connects with the middle pin when you click, and clip off the other side pin.

14c. Solder the cap's positive lead to the remaining side pin of the bump switch, and solder one end of the timer resistor to the same pole.

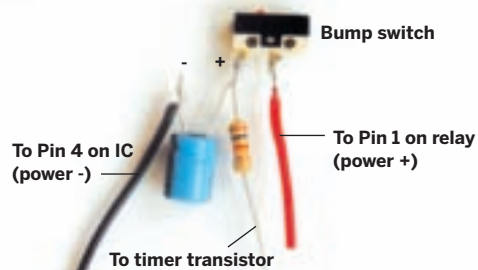

14d. Solder a 2" red lead to the middle bump switch pin, and then glue the switch into the body, through the hole you cut earlier.

14e. Solder a lead between the transistor's middle pin and the free end of the timer resistor.

15. POWER TO THE MOTORS

15a. Solder two 2" black wires to the motors' negative terminals, then solder the stripped ends of these two wires together side-by-side.

15b. Solder a third, 3" black wire to these joined ends, then solder it to the control chip's output pin (Pin 5).

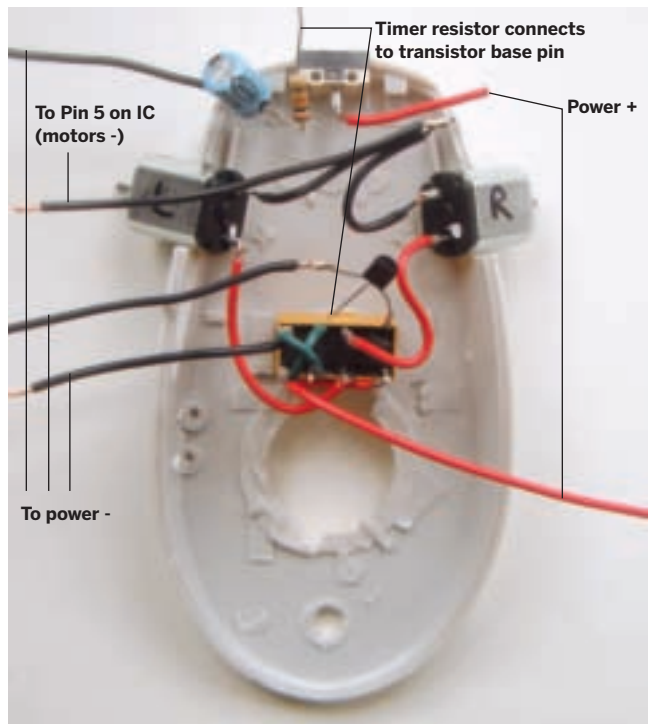

16. INSTALL THE LM386 CONTROL CHIP

16a. Bend Pins 1 and 8 of the op-amp chip down and solder them together.

16b. Find the black wires from the transistor, the relay, and the capacitor, strip the ends, and solder them all together side-by-side.

16c. Solder the battery snap's negative wire to this same junction.

16d. Solder a 1" black wire to Pin 4 of the op-amp, and the other end to the negative wire junction.

16e. Solder the red wire from the relay to Pin 6 of the chip. Then glue the chip into the mouse case in dead bug mode.

That's it for Mousey's bottom half!

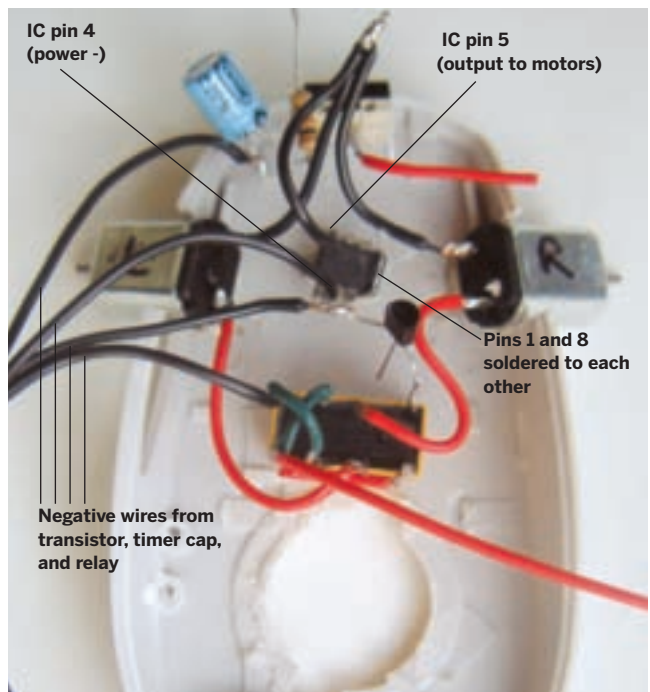

The LM386 control chip wired and ready for action.

17. INSTALL MOUSEY'S EYES

17a. The buttons on most computer mice are separate, semi-attached pieces of plastic. To give Mousey's eyes a solid foundation, glue the buttons down, wait until dry, and then drill small holes in Mousey's lid to thread the eyestalks through.

17b. Thread about 1¾" of stalk through each hole. On the inside, trim the two red wires so that they just overlap against the underside of the lid, then solder them together. Run the black wires back along the inside and bend them down where the op-amp is located (but don't solder them yet).

17c. Make the sensitivity booster circuit by cutting a 1" piece of red wire, and soldering one end to the 1k-ohm resistor and the other end to the LED's anode.

17d. Connect the booster by soldering the free end of the resistor to the middle pole of the toggle switch and the LED cathode to the junction of the two red eyestalk wires.

17e. Mark where the LED sits, gently bend it aside,

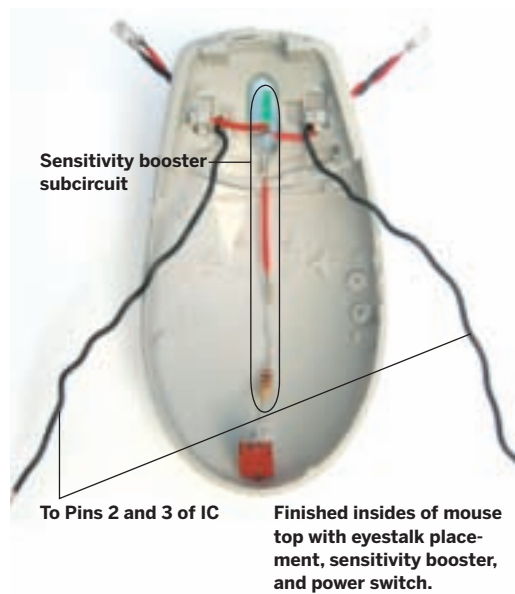

and drill a hole in the case for the LED to poke out of (unless it can already come up through the scroll wheel slot). Push the LED through and hold it in place with electrical tape.

18. IT'S ALL ABOUT CONNECTIONS

We almost got bot! Now install the front whisker and make the final connections between power, the switch, and the control chip. There's no photo of these final steps, because they happen inside a semi-closed mouse. But you're such a circuit-hackin' fool by now that you don't need us anymore.

18a. Solder the black eyestalk wires to Pins 2 and 3 on the LM386.

18b. Solder the red battery wire to either of the side poles of the toggle switch.

18c. Solder a red wire from the toggle's center pole to Pin 6 of the IC, or to either Pin 1 or Pin 8 of the relay. Solder another red lead from the unconnected bump switch pin to one of these same locations.

18d. Cover all exposed leads and junctions with electrical tape to prevent shorts. Then glue or



Congratulations! It's a slightly anxious, light-seeking robot.

loosely tape your plastic "whisker" to the bumper switch, so that it clicks on impact.

18e. Finally, snap in the battery, and screw or tape the two mouse halves back together. Then put Mousey on the floor, switch it on, and watch it go.

FINISH **X**

NOW GO USE IT >>

USE IT.



ENJOY YOUR ROBOT MOUSE

MOUSEY GAMES

If all went well, Mousey the Junkbot's behavior will be apparent once you flip its tail. The robot should zoom away and eventually hone in on the brightest area in the room. It works best if you limit Mousey's surroundings to just one source of illumination – one light or sun-soaked window. Here are some other fun experiments:

Put Mousey in the hallway and close all doors except one. Make the open room as bright as possible, and see if Mousey eventually scuttles in there. Try orienting Mousey in different starting positions.

Tune Mousey's light sensitivity by bending the eyestalks. Move the stalks farther apart, closer together, and bent in different directions until you get the steering you're looking for.

Use a flashlight to lure Mousey around. This will drive pets insane! But be careful; agitated pets will attack your robot and try to rip its components out.

TROUBLESHOOTING A WAYWARD MOUSEY

If you turn on Mousey and nothing happens (cue laughing clarinet, "Wha-wha-WHAAAA"), or if it acts strangely, turn it off immediately. Something went wrong with the build. Here are a few things to check:

First, ask yourself the tech-support alpha question: is it plugged in? Make sure that the battery is new, the battery snap is well-seated, and its positive and negative wires are properly connected. Then make sure that bare wires, pins, and solder joints are not making unauthorized contact with one another. One sign that you may have such a short circuit is if the battery gets warm.

Next, double-check all solder connections against the instructions. Besides being in the right places, they should all be fat, shiny, healthy-looking joins. Use the multimeter to check resistances, and resolder anything suspicious.

If Mousey frantically spins in a tight circle, you've probably hooked the motors up incorrectly. Reverse

the wires that connect to the motor on the side that's going backwards.

If it's a broader circle, the motors might be wired correctly, but just not level with each other. If so, re-glue the motors so they're symmetrical and make sure the tires are the same size.

If Mousey's always heading backwards, swap the wiring on both motors.

RESOURCES

This project is adapted from my book *Absolute Beginner's Guide to Building Robots*. You can find schematics and installation instructions for additional Mousey hacks on my robot page at Street Tech, streettech.com/robotbook. More cool hardware hacks live in Dave Hrynkiw's *Junkbots, Bugbots & Bots on Wheels*.

To find other ideas for hacking your Mousey, and other LM386-based bots, Google "robot +LM386," "herbie +LM386," and "Randy Sargent +robot."

To learn more about DC motors, and see a dissected version of the motor used in this project, see <http://xrl.us/fkxh>.

Make:

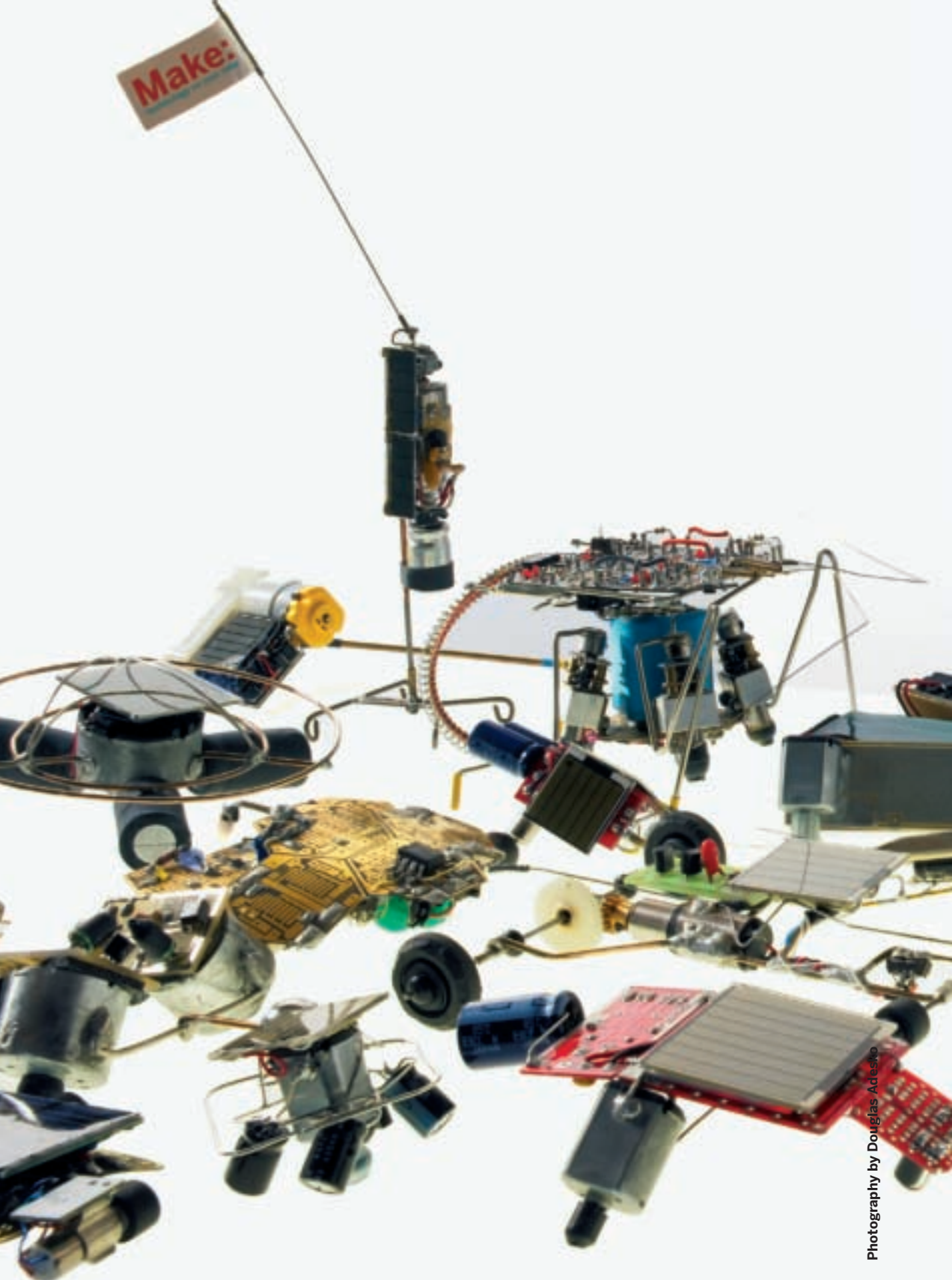

Photography by Douglas Adesio

TWO BEAMBOTS: TRIMET AND SOLARROLLER

By Gareth Branwyn

Solder together one simple circuit and use it to control two very different solar-powered robo-critters: a little satellite that scoots and bumps around, and a mini cart that just keeps a-rolling until the sun goes down. ❖

Set up: p.80 Make it: p.81 Use it: p.87

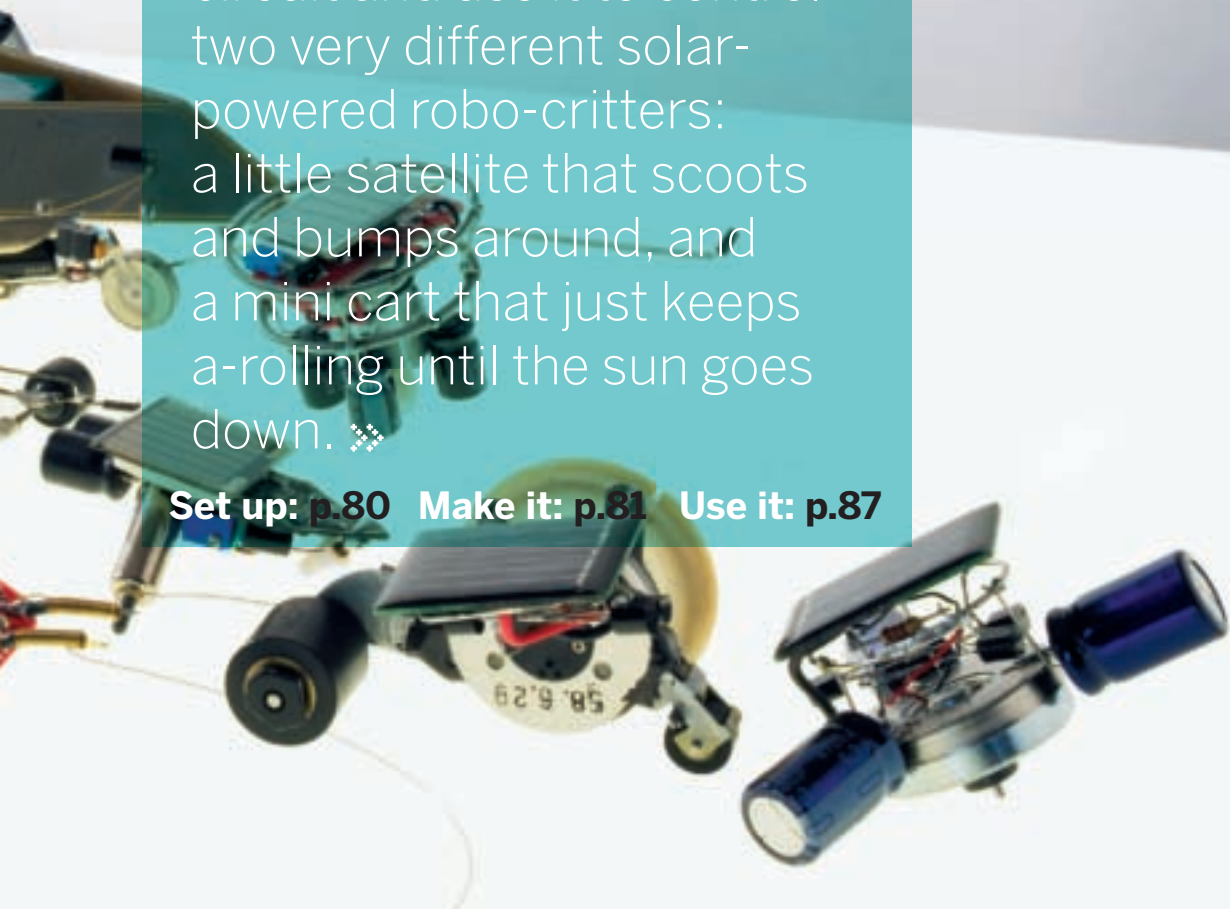

GO SOLARENGINE!

The low-tech, analog, dumpster-diving, and hack-friendly world of BEAM robotics (see *page 54*) has produced a bestiary of bot types, including Symets, Rollers, Walkers, Jumpers, Climbers, Swimmers, Flyers, and Crawlers. Many of these creatures can be powered and controlled by a Solarengine, a simple and popular BEAM circuit that draws energy from a solar cell and temporarily stores and dispenses it using one or more capacitors.

We'll make a couple of voltage-triggered Solarengine circuits, and then build them into two little bots: a Trimet, which looks like a satellite in orbit as it's moved around by a spinning, top-like base, and a Solarroller, which drives straight ahead in fits and starts. These light-sensitive critters will look cool and très geeky on your desk, as long as you can keep them from wandering off the edge (they're both active diurnally, and they don't have an off switch).

Gareth Branwyn wrote "A Beginner's Guide to BEAM" on page 54.

FAST REACTOR DESIGN

BEAMbots use simple circuits that interact with the world directly. Unlike control-freak robots, their brainless, reflexive reactivity is the whole point.

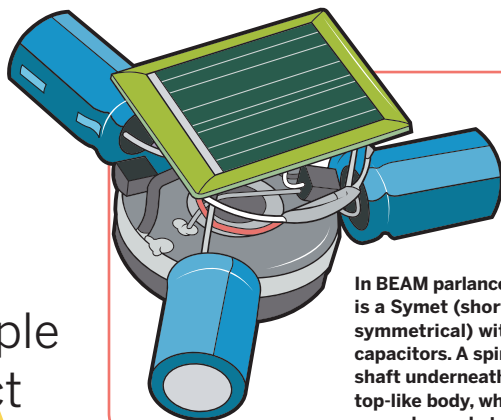

In BEAM parlance, a Trimet is a Symet (short for symmetrical) with three capacitors. A spinning drive shaft underneath pulls its top-like body, which bumps around any obstacles.

Solarrollers are little solar-powered race cars. At BEAM and other robot competitions, builders pit Solarrollers against each other in a kind of robo-mechanical Pinewood Derby.

Our Trimet and Solarroller bots are based on a voltage-triggered (Type 1) Solarengine. These circuits collect energy from a small solar cell, and periodically release it when there's enough stored up to actually do something, like run a motor.

The solar cell converts light into electrical energy, slowly juicing up the capacitor (or multiple capacitors).

The capacitor collects and stores a voltage, which discharges whenever the circuit is completed between its two terminals.

The 1381 voltage trigger measures the voltage across the capacitor, and sends a trigger signal once it's high enough (2.4 volts with a 1381-G trigger).

When the base pin of the 3904 transistor receives the trigger signal, it completes a connection that allows the capacitor's power to discharge through the motor.

The motor runs intermittently, whenever it receives a power dump from the capacitor.

During discharge, current flows to the base of the 3906 transistor. This takes the 1381 trigger offline, allowing it to reset, and routes current to the 3904 base, which keeps the motor circuit flowing until the cap is fully discharged.

The 2.2k Ω resistor reduces the voltage to the 3906 base pin, so it diverts less power away from the motor during discharge. This makes the circuit more efficient.

➕ Solarengine schematic: makezine.com/06/beambots

SET UP.

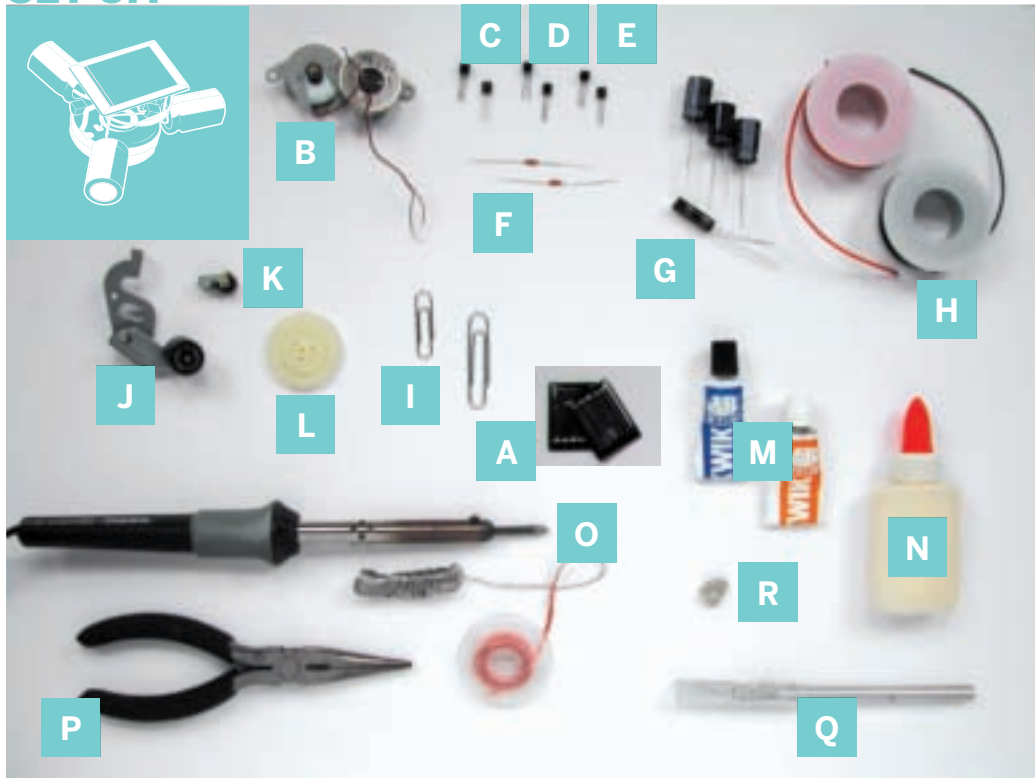

MATERIALS

The following parts will build two Solarengines. Just get one of each if you're only building the Trimet or the Solarroller, but not both. All part numbers refer to Solarbotics (solarbotics.com):

[A] 37x33mm polycrystalline solar cell, part #SCC3733 (2)

[B] Cassette motor (2)
From an old Walkman or other player, part #MCM2

[C] 1381-G voltage trigger IC, part #1381-G (2)

[D] 2N3904 ("3904") NPN transistor, part #TR3904 (2)

[E] 2N3906 ("3906") PNP transistor, part #TR3906 (2)

[F] 2.2kΩ resistor (2)

[G] 4700µF capacitors (4)
Or use three 4700µF capacitors (for the Trimet), and 1 "supercap" such as a 0.33F Gold Capacitor, part #CP.33F (for a higher-performance Solarroller)

[H] Hook-up wire, red and black 24-gauge stranded

[I] Paper clips (2) one small, one large

PARTS YOU'LL ONLY NEED FOR THE SOLARROLLER:

[J] Pinch roller and arm from a VCR, or similar Smooth rubber roller, about 5/8" in diameter and 5/8" wide

[K] Pinch roller and arm from a cassette player, or similar Smooth rubber roller, about 1/2" in diameter and 1/4" wide

[L] Drive wheel of any lightweight material, with a diameter slightly greater than the motor casing
Between 1 1/2" and 1 3/8" is good. An old VCR might have a suitable pulley, or try the disc that holds the control rods in a servomotor. You can also use a wheel from a toy, or any other right-sized plastic disc.

Rubber band

[M] Epoxy

[N] White glue

TOOLS

[O] Soldering equipment
Iron, stand, solder, and solder-sucker, desoldering bulb, or braid

Dremel tool with grinding wheel, cut-off wheel, and router bits

"Third hand" tool with alligator clips Two are ideal

[P] Needlenose or long-nose pliers

Wire cutters

[Q] Hobby knife

Medium-grade sandpaper or metal file

Ruler

[R] Poster putty or tape

Safety glasses

MAKE IT.



BUILD YOUR BEAMBOTS

START 

Time: A Day Complexity: Medium Low

1. BUILD THE SOLARENGINE CONTROL CIRCUITS

We'll be freeforming these circuits, which means connecting components together directly, without a board. Normally I would breadboard and test my circuits before soldering, but this one is so simple and has so few parts that we can live dangerously. Parts are easily desoldered and resoldered if there's a problem.

1a. Face the two transistors up with their pins toward each other. Solder the base pin (middle) of the 3904 transistor to the collector pin of the 3906 (the right pin, as you read the printing).



1b. Use needlenose pliers to gently bend the 3904 emitter pin (left) 90 degrees to the side and its collector (right) 90 degrees up. Bend the 3906 base pin (middle) 90 degrees up and its emitter (left) 90 degrees to the side. Solder the 2.2kΩ resistor from the 3904 collector to the 3906 base.



1c. Trim excess lead length from previous step. Place the 1381 voltage trigger to the right of the 3906, facing the same way. Solder its Pin 3 (right) to the 3904 emitter and its Pin 1 (left) to the 3906 collector. Finally, arc its Pin 2 (middle) around and solder it to the 3906 emitter (left). There's your basic circuit, ready for motor and power!

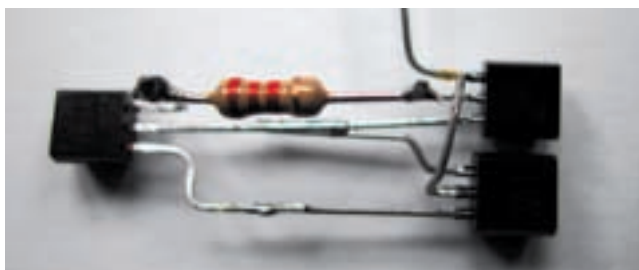

1d. If you're making both BEAMBots, build a second Solarengine circuit by repeating steps 1a-1c above. From here, you can continue on to step 2 to build a Trimet, or jump ahead to step 3 and build a Solarroller.

2. MAKE A TRIMET

2a. Prepare the motor by removing any mounting tabs with a Dremel grinding wheel. Then use sandpaper or a metal file to scuff the drive-shaft side of the case until you're down to the shiny metal underneath. Really scuff it up good; you'll be soldering capacitors directly to the case, and they'll need to hold as the Trimet drags and bumps around.



2b. Clip the negative/cathode leads on the three 4700 μ F capacitors so there's just enough wire to solder them to the motor casing. Bend the positive/anode leads up, making sure they comfortably clear the casing. Find 3 equidistant points at the perimeter of the motor, and solder the 3 cathodes to these points so that the capacitors form an equilateral triangle radiating out from the motor's center. Use generous gobs of solder, and use poster putty or tape to hold the caps in place while you solder.



2c. Center the circuit assembly over the motor, and solder a scrap lead from the 3904 emitter to the motor casing. This grounds the circuit, while also attaching it to the motor. For optimal balance, bend this connecting wire at 90 degrees, and try to position the circuit in the middle of the motor.



2d. The motor case is our circuit's ground (-); now let's work on the power (+) side. Take a small paper clip and bend it into a ring with the same diameter as the motor. (Conveniently, Walkman motors are the size of a quarter, so you can use one as a form to bend the clip around.) When you have a decent circle, solder it together.



2e. Bend and trim the capacitor anode leads evenly, so that they extend just above the control circuit. Solder the “power ring” to the ends of the 3 leads, preserving the equilateral symmetry.

2f. If you can bend the 3906 emitter lead to reach the paper-clip ring, do so, and solder it on. Otherwise, connect it with a short piece of wire or scrap component lead.

2g. Now, the solar cell. If yours has pre-tinned pads but no wires (most small cells come this way), start by soldering the 2 wires onto it — but be careful, because solar cells are fragile. Then solder the positive/red wire to the ring and the negative/black wire to the motor casing. Make the wires long enough so you can still work on the circuit, but short enough so they’ll stow neatly underneath when you finally glue the solar cell down onto the ring.

2h. Connect the motor. Solder the negative/black motor wire to the point where the 2.2k Ω resistor meets the 3904 collector. Solder the positive/red motor wire to the paper-clip ring.

Now, place the solar cell on top of the Symet and shine a light on it, or put it in the sun. After 10 seconds or so, it should fire and scoot along, or spin around if you’re holding it by the driveshaft underneath. If so, congratulations — you’re the proud parent of a BEAMbot! You can go ahead and glue the solar cell onto the paper-clip ring. Or, if the cell stays in place without glue, leave it that way so that people can peek under the hood.

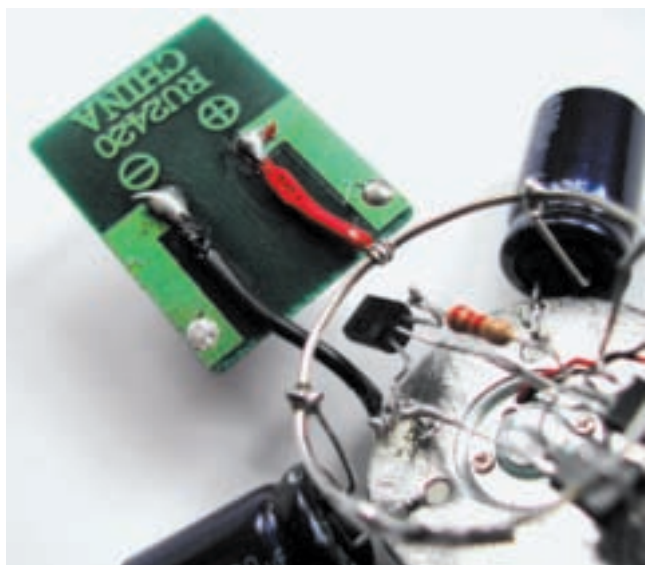

3. MAKE A SOLARROLLER

Solarroller builders have used all sorts of materials, from Lego bricks to soldered paper clips to computer mouse cases. This popular approach relies on parts from an old cassette player and VCR. Your mileage may vary, depending on the parts that you use for the body and drivetrain.

3a. Cut the arms on the 2 pinch rollers with a Dremel and cut-off wheel, so that they make full, flat contact against the motor casing. The Solarroller will stand on the triangular base that's formed by these 2 idler wheels and the larger drive wheel that will go onto the motor's drive shaft.



3b. Prepare your drive wheel. First, check that it will fit on the motor's drive shaft. (The hole in the hub of the disc I used was too small, so I reamed it out using a Dremel router bit.) Then glue a rubber band around the outside of the wheel, to improve traction. Cut the band, smear a thin layer of glue onto one side, and when it gets tacky, carefully roll the wheel over this "tire" until it comes full circle. Let the join overlap, then use a hobby knife to cut away excess rubber and make sure the ends are perfectly joined.



3c. Epoxy the 2 idler wheel arms into position on the motor casing, then fit the drive wheel onto the motor shaft without gluing it (use poster putty to hold it on, if needed). It is critical that all 3 wheels run parallel to each other and make full contact with flat ground when the Solarroller is standing. If you're using the Solarbotics motor, you can affix the larger roller arm to the motor's large mounting tab, pointing toward what will be the front, and leave the two other mounting tabs and holes pointing up on top, for attaching the circuit and solar panel.



3d. Cut about 4" of wire from a large paper clip and fashion it into a U shape. For the Solarbotics motor, it can be just wide enough to run between the two upper mounting holes. Trim the remaining piece of paper-clip wire and solder it across the U as a cross-brace, about 3/4" from the open end.



3e. Epoxy a capacitor directly to the motor casing, running horizontally, on the side opposite the drive wheel. The leads should point backward, with the cathode (-) closer to the motor.



3f. Solder (or epoxy) the paper-clip frame atop the motor casing, using the two mounting holes if present. Since we didn't glue the drive wheel on yet, you can remove it to access the top of the motor. For extra sturdiness, you can position the frame so the cross-brace rests on the capacitor, and epoxy the brace onto the cap. Glue on the drive wheel.



3g. Position the Solarengine circuit underneath the paper-clip frame, next to the cap, on the side opposite the motor. Solder the 3906 emitter (left) pin to the positive/anode lead of the capacitor. The connection should be short enough so that the cap holds that end of the circuit up in the air.



3h. Turn the Solarengine upside down and solder a scrap component lead to the 3904 emitter pin at the point where it attaches to the 1381 trigger's Pin 3. Bend the capacitor's negative/cathode lead around the undercarriage side of the cap's barrel, and solder it to the lead you just connected to the 3904. This will anchor the other end of the circuit.



Transistor Action

TRANSISTOR

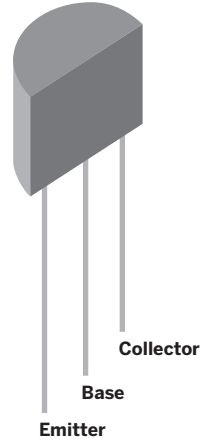

Bipolar transistors can act as switches, connecting parts of a circuit just like a mechanical switch would. In an NPN transistor, applying a voltage with the positive side to the base and the negative side to the emitter allows current to flow from emitter to collector. A PNP transistor goes the opposite way; running a negative voltage across from the base to the emitter allows current to flow from emitter to collector.

3i. If your solar cell doesn't have wires, attach some to the pads marked (+) and (-). The wires only need to be long enough to reach the pins on the capacitor. Thread the solar cell's wires through the frame and epoxy the cell to the top. When the epoxy is set, solder the solar cell's positive to the cap's positive/anode and the cell's negative to the cap's negative/cathode.

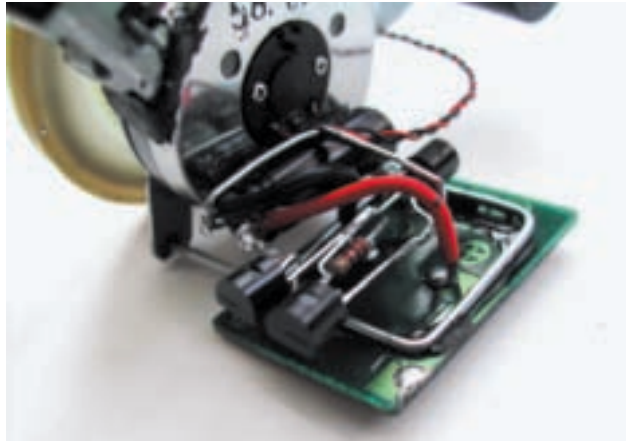

3j. Finally, connect the motor. Solder the positive/red motor wire onto the 3906 emitter (left) pin and the negative/black wire to the 3904 collector.

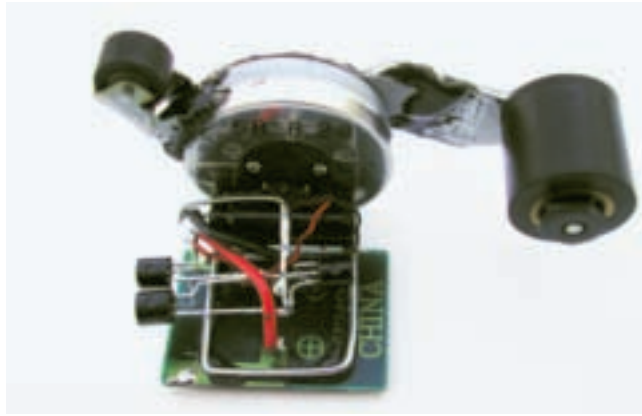

Now, put the Solarroller on a flat surface in the sun, or shine a flashlight on the cell. After a little while, the circuit will trigger, the capacitor will dump, and your Solarroller will take off for a short run. Shine, wait, and repeat.



FINISH X

NOW GO USE IT >>

USE IT.



BEAM ME UP, SCOTTY

TROUBLESHOOTING

If your BEAMbot doesn't make you beam, carefully examine all connections, resolder anything that looks weak, and separate any components that might be touching (shorting). It's a simple circuit, so not much can go wrong besides incorrect connections or bad joins.

FURTHER HACKING IDEAS

On the Trimet, add an outer paper-clip ring. This creates a bumper that will help prevent the robot from getting stuck.

On the Solarroller, replace the regular 4700 μ F capacitor with a "supercap" like a 0.33F Gold Capacitor, as shown in the project photos. These capacitors can take several minutes to juice up, but they'll make your Solarroller take off like a bat outta hell.

You can easily convert an old Sony Walkman into a great Solarroller. Leave the motor, roller wheels, and pulleys in the original frame's base piece, and use it as the vehicle's chassis.

Try Andrew Miller's more efficient variant of the basic Solarengine, which is almost as easy to build. You need a different resistor, an additional capacitor, and a diode, but you can lose the 3906 transistor. Varying the value of the small cap, between 0.47 μ F and 47 μ F, lets you "program" different discharge times. (See schematic at: makezine.com/06/beambots.)

Once you have the basic ideas down, you can go crazy, improvising BEAMbots with greater storage capacity, better obstacle-avoidance strategies, or swankier, more attention-getting designs. Here are some Symet and Solarroller variations (pictured at right).



RESOURCES

There are many more hacks and variations on these two project types, as well as other applications for the Solarengine. For more information, see "Getting Started in BEAM" on page 57.

➤ Schematic for Miller variant of Solarengine circuit: makezine.com/06/beambots

DIY

SCIENCE



BEETLEBOT



Ultra-simple bugbot navigates obstacles with feelers and switches. By Jérôme Demers

The Beetlebot is a very simple little robot that avoids obstacles on the floor without using any silicon chip — not even an op-amp, and certainly nothing programmable. Two motors propel the bugbot forward, and when one of its feelers hits an obstacle, the bot reverses its opposite motor to rotate around and avoid it. The project uses only 2 switches, 2 motors, and 1 battery holder, and it costs less than \$10 in materials (or free, with some scrounging).

Beetlebot in 10 Easy Steps

1. Cut pieces of heat-shrink tubing and use a heat gun or other high-heat source to shrink them onto the motor shafts. Trim the tubing evenly, with a little bit running past the ends of the shafts. These will act as tires, improving traction (Figure B).

2. Glue the SPDT switches to the back of the battery holder, at the end with the wires. The switches should angle out at the 2 corners with their levers angled in toward each other, as shown in Figure C. Also, the contacts farthest from the buttons on each (the normally closed contacts) should touch. This will be the front end of our bugbot.

3. Cut the metal strip, mark enough length at each end to hold a motor, and bend each end in at about a 45° angle. This is your motor plate.

4. Examine or test your motors to determine their polarity. Tape the motors onto opposite ends of the motor plate so that their shafts point down and angle out. Orient their positive and negative contacts so that they'll spin in opposite directions.

Photography by Jérôme Demers

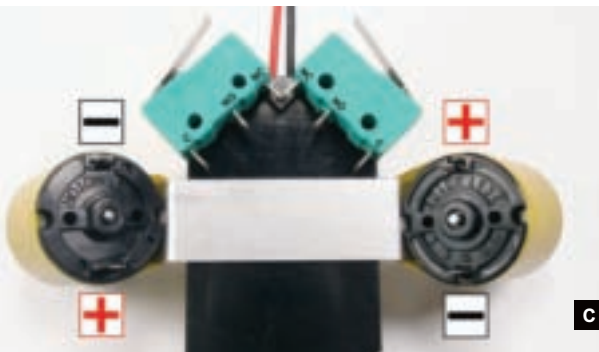
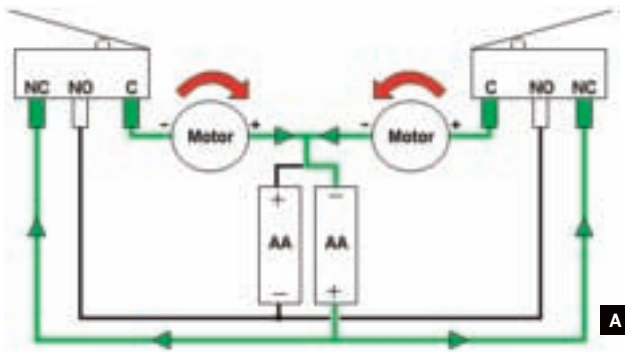

Fig. A: Diagram of Beetlebot running free, not bumped into anything; both motors draw current from the right battery only. Fig. B: Heat-shrink tubing acts as tires, giving traction to the motor shafts.

Fig. C: Switches and motor plate glued to the back of the battery holder. Fig. D: Bent paper clip threaded through a bead and glued to the rear end of the battery holder to make a rolling caster.

MATERIALS

- 1.5V motors (2) You can often scavenge these from toys, dollar store fans, etc.
- SPDT (single pole double throw) momentary switches with metal tabs (2) You can scrounge these from an old VCR or mouse, or buy new ones for \$1–\$4 apiece.
- Electrical wire around 22 gauge
- AA batteries (2) You can also use AAAs.
- AA battery holder
- Spherical bead plastic or wood
- Heat-shrink tubing to shrink to the widths of the motor shafts and the antennae connectors
- Black electrical tape
- Terminal connectors, spade type, small (2)
- 1"×3" piece of scrap metal plate I used aluminum.
- Paper clips (4)
- Cyanoacrylate (Super/Krazy) glue or epoxy
- Soldering iron and solder
- Toggle switch (optional) for on/off switch

FOR THE SHELL (OPTIONAL)

- Round plastic lid I used a lid from a container of hair gel, but you can also use a peanut butter jar lid or anything similar.
- Auto body filler putty or epoxy glue
- Black and red enamel paint and primer
- Clear varnish
- Small, thin magnets (2) to attach shell to body

5. Use cyanoacrylate glue or epoxy to glue the motor plate down onto the back of the battery holder, just behind the switches (Figure C). Orient the motors so that the left motor spins counterclockwise as you view it from below, and the right one spins clockwise. For aesthetics, I then covered the plate with black electrical tape.

6. Unbend a paper clip, slip it through the bead, and bend it symmetrically on either side to make a caster (Figure D). Attach each end of the clip to the corners of the battery holder at the back. I used hot glue — not very professional. You could also try bending the clip ends under and soldering them to the battery connection tabs, but if you apply too much heat to the tabs, you might melt the plastic and ruin your battery holder. Beware!

Next we'll wire up the circuit, but first, an explanation: the key is that the 2 batteries work separately. Battery holders usually connect cells in series and combine their voltages, but with the Beetlebot, a wire soldered between the 2 puts them into separate subcircuits. The motors draw from only 1 battery at a time. Each switch's common connection (C) runs to a motor. The switches' normally open (NO) terminals connect together and run to the battery



E



F



G

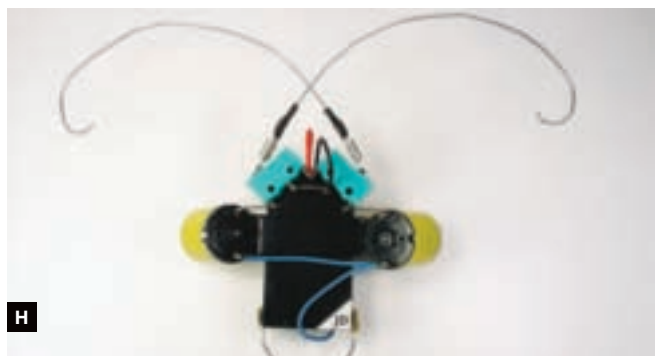

H

Fig. E: Use pieces of paper clip and insulated wire to solder connections between the switches, motors, and battery holder. **Fig. F:** Complete wiring, with battery holder leads soldered to switch terminals.

Fig. G: Removable antennae made from paper clips use spade connectors to slip onto switch levers. **Fig. H:** The bare-bones Beetlebot, finished and working, but without any switch or decorative shell.

holder's negative lead, while the switches' normally closed (NC) legs run to the positive lead.

When the bot isn't hitting anything, voltage from the positive-side battery splits and runs through both motors via the NC terminals, and the negative-side battery is not used at all. But when a switch button is activated, it closes the circuit with the negative-side battery, through the NO terminal. This reverses the motor direction on that side while the unactivated side continues running forward, which results in a quick turn away from the obstacle.

When both switches activate, both motors momentarily run backward, and the bot backs away. (The feelers cross in front, so a bump on one side activates the button on the opposite side.) That's all there is to it. Now, back to the build.

7. Solder together the 2 switches' NC terminals that are close or touching. Then solder together their NO terminals, the middle legs. I use pieces of paper clip for short joins like this, since it's faster and stronger. Then connect the common leg of each switch to the front terminal of its nearest motor (Figure E, top).

8. Solder a wire between 2 motors' rear terminals. Connect another wire from either one to any contact

point on the battery holder that's electrically in between the 2 batteries (Figure E, bottom). This is the Beetlebot's all-important "third connection."

9. Finish the wiring by soldering the battery holder's positive lead to the switches' NC terminals, and its negative lead to either of the switches' NO terminals (Figure F).

10. Remove the insulation from the 2 spade connectors, and unbend 2 paper clips. Slip the connectors over the paper clips, then squeeze them down with pliers and solder in place. Dress up the connection with some wide heat-shrink tubing (Figure G). These are the Beetlebot's feelers. The spade connectors clip onto the switch levers, which makes them easy to detach for packing, and prevents damage to the fragile SPDT switches. The long paper clips give sufficient leverage to activate the switches, even if they seem hard to trigger with your finger directly.

Your robot is finished (Figure H)! Add 2 batteries, and it should come to life. If it spins in a tight circle or runs backward, you need to reverse one or both of the motor connections. To change the bot's speed or to make it run straighter, bend the metal plate to adjust the motors' angles.



I



J

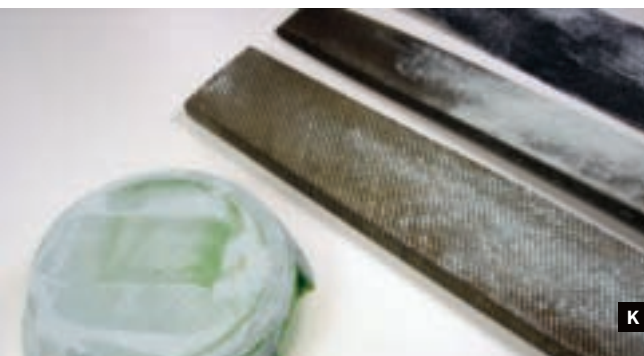

K



L

Fig. I: The Beetlebot's on-off switch connects between the motors and batteries. Fig. J: Plastic lid cut to accommodate motors and antennae.

Fig. K: Building up and shaping the shell with auto body putty. Fig. L: Dime-sized masking tape circles give Beetlebot its spots.

For additional diagrams of how the circuit works, see makezine.com/12/diyscience_beetlebot.

Adding an On/Off Switch (Optional)

Every time you want to stop the robot, you need to remove the battery, which can get annoying. To solve this problem, splice a toggle switch onto the “third connection” wire between the motors and the batteries. Cut the wire, then solder in the switch and glue it to the edge of the battery holder. I neatened this connection up with more heat-shrink (Figure I).

Making the Shell (Optional)

Now here's the aesthetic part: adding the shell. I made mine out of the green plastic lid from a container of hair gel.

1. Fit the lid over the bot and cut holes in the sides to make room for the motors and the front switches/antennae (Figure J).

2. To make the shell more round, cover it with auto body putty (watch out — it cures pretty fast!) or epoxy glue, and then use files to shape and smooth it (Figure K). For final touch-up, I filled in any holes with a softer putty.

3. After sanding the lid smooth, give it a couple coats of primer, and then paint it. To make a ladybug beetle pattern, I started by painting the whole thing black (I also painted the antennae black). Then I used a dime as a template to cut round pieces of masking tape, which I applied to the lid along with a thin masking tape centerline (Figure L).

I painted glossy red over everything, and then removed the tape. For the final polish, I sanded the whole thing with very fine sandpaper and some water, which gives a glossier finish than sanding dry; this is a trick I learned from a friend who was restoring a guitar. I let everything dry and gave it 2 coats of clear varnish.

4. To connect the shell to your robot, you can glue it directly to the battery holder, or you can use magnets; glue one inside the lid and another in a matching position on the battery holder. This lets you remove the shell easily, to show your friends the insides of your biomech bug!

Jérôme Demers is a student in electronics engineering at the University of Sherbrooke in Québec. He is currently working on advanced sumo robots in both the 500g and 3kg categories.