

CATALOGUE



CONTENTS

Introduction	3
Certifications	4-5
References Standards	6
Ball Valves	7
Trunnion Mounted Ball Vaves	8
Product Range	9
Available Design Options	10
Quality & Testing	11
Ball Valve Standard Design	12-13
Technical Features	14-15
Standard Material Specification	16
Overall Dimensions & Weights	17-24
Technical Features	25
Flow Data	26
Stock Of Ball Valves	27



Based in Northern Italy, TIV VALVES, formerly TY Valve Italy, was founded in January 2010 to fill a void in quality custom engineered API 6D Ball Valves in the Oil & Gas market.

Since then, we have shipped more than 25,000 valves in five continents to all the main End Users and EPC's companies.

We meet your simple yet crucial requirements with high quality Italian design, concentrated production lots, severe application and short lead times. We sell high quality engineered valves with an Italian design.

Applications for our severe service designed valves include: corrosive fluids, high temperature, cryogenic, underground, and any special requirement from our customers.

We follow API 6A, API 6D, ISO 15848, ISO 10497 standards.

TIV VALVES meets your testing requirements in accordance with industry standards and customer specifications with: fugitive emission, performance and functionality, high pressure gas, high temperature, low temperature, fire safe, NDE Inspections.

We provide total service and support with our valves. Our procedures and testing can be conducted on-site if requested.



CERTIFICATIONS

TIV VALVES is certified ISO 9001, API spec. Q1, API 6D, API 6A, CE/PED, EURASEC Fire safe certified API 607, API 6FA & ISO 10497, fugitive emission certified ISO 15848 and approved by major oil/petrochemical companies.

ATEX



ISO 9001



PED



ISO 14001



ISO 18001



FIRE SAFE



SIL 2



SIL 3



EURASEC



API 6D



API 6A



* Certificates here appearing with the former name TY Valve Italy will be updated as soon as released by Certification Authorities



- API Q1 Specification for Quality Programs for the Petroleum, Petrochemical and Natural Gas Industry
- ISO TS 29001 Petroleum, petrochemical and natural gas industries - Sector-specific quality management systems - Requirements for product and service supply organizations
- API 6A (ISO 10423) Specification for Wellhead and Christmas Tree Equipment
- API 17D Design and Operation of Subsea Production Systems-Subsea Wellhead and Tree Equipment
- API 6D (ISO 14313) Specification for Pipeline Valves
- API 6DSS (ISO 14723) Specification for Subsea Pipeline Valves
- API 598 Valve Inspection and Testing
- API 607 Fire Test for Quarter-turn Valves and Valves Equipped with Nonmetallic Seats
- API 608 Metal Ball Valves-Flanged, Threaded and Welding Ends
- API 6FA Specification for Fire Test for Valves



- ASME Boiler and Pressure Vessel Code, Sect. VIII Div.1 & 2
- ASME B1.1 Unified Inch Screw Threads, UN and UNR Thread Form
- ASEM B1.20.1 Pipe Threads, General Purpose (Inch)
- ASME B1.5 ACME Screw Threads
- ASME B16.10 Face to Face and End-to-End Dimensions of Valves
- ASME B16.20 Metallic Gaskets for Pipe Flanges: Ring-Joint, Spiral-Wound, and Jacketed
- ASME B16.25 Buttwelding Ends
- ASME B16.34 Valves Flanged, Threaded and Welding End
- ASME B16.47 Large Diameter Steel Flanges: NPS 26 Through NPS 60
- ASME B16.5 Pipe Flanges and Flanged Fittings: NPS 1/2 through NPS 24
- ASME B31.3 Process Piping
- ASME B31.8 Gas Transmission and Distribution Piping Systems
- ASME B36.10 Welded and Seamless Wrought Steel Pipe



- BS 6364 Specification for valves for cryogenic service
- EN 12266-1 Industrial valves. Testing of valves. Pressure tests, test procedures and acceptance criteria. Mandatory requirements.
- EN 12266-2 Industrial valves. Testing of valves. Tests, test procedures and acceptance criteria. Supplementary requirements
- EN ISO 17292 Metal ball valves for the petroleum, petrochemical and allied industries
- EN 14141 Valves for natural gas transportation in pipelines. Performance requirements and tests
- EN 473 / ISO 9712 Non-destructive testing - Qualification and certification of NDT personnel - General principles



- ISO 10497 Testing of valves - Fire type-testing requirements
- ISO 15848 Industrial valves - Measurement, test and qualification procedures for fugitive emissions. Part 1: Classification system and qualification procedures for type testing of valves. Part 2: Production acceptance test of valves.
- ISO 17292 Metal ball valves for petroleum, petrochemical and allied industries
- ISO 5208 Industrial valves - Pressure testing of metallic valves
- ISO 9001 Quality management systems - Requirements



- MSS SP-06 Standard Finishes for Contact Faces of Pipe Flanges and Connecting-End Flanges of Valves and Fittings
- MSS SP-25 Standard Marking System for Valves, Fittings, Flanges and Unions
- MSS-SP-44 Steel Pipeline Flanges
- MSS-SP-45 Bypass and Drain Connections
- MSS-SP-55 Quality Standard for Steel Castings for Valves, Flanges and Fittings and Other



- NACE MR0175 - ISO 15156 Petroleum and natural gas industries - Materials for use in H₂S-containing environments in oil and gas production - Parts 1, 2, and 3



- NACE MR 0103 Materials Resistant to Sulfide Stress Cracking in Corrosive Petroleum Refining Environments
- ASTM Material Specification

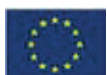

- PED (97/23/CE) Pressure Equipment Directive
- Atex (94/9/CE) Explosives Atmospheres Directive

DESIGN FEATURES

- Anti Blow-Out Stem
- Antistatic Design
- Fire Safe Design
- Soft Seated or Metal Seated
- Low Fugitive Emission
- Double Block and Bleed
- Welded or Bolted Body
- Self Relieving Seats or Double Piston Effect
- Extended Stem
- Cryogenic Extended Bonnet

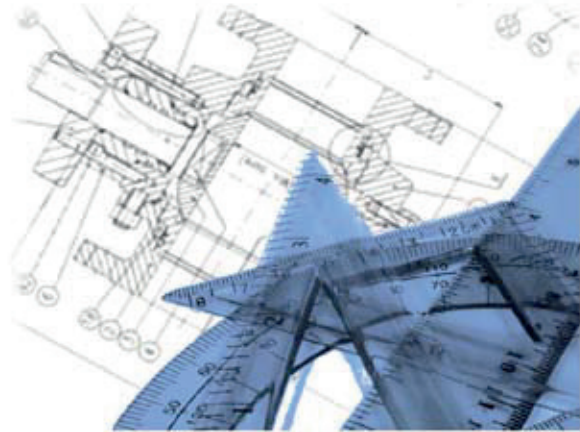

SEVERE APPLICATIONS

- Corrosive
- Erosive
- High Temperature
- Cryogenic
- Underground
- Subsea
- Other Special Requirements

MATERIALS

- Carbon Steel
- Lt Carbon Steel, Impact Tested
- Ferritic/Austenitic Stainless Steel (Duplex - Super Duplex)
- Austenitic Stainless Steel
- Austenitic Stainless Steel (6Mo)
- Hardened Stainless Steel - Precipitation
- Martensitic Stainless Steel
- High Strength Low Alloyed Steel
- Non-Ferrous Steel, Nickel Alloy
- Titanium
- Exotic Materials





TRUNNION MOUNTED BALL VALVES

Technical features

Bi-directional

The valves are designed to block flow in both upstream and downstream directions.

Body Joint Sealing

The double sealing action of O-Ring and Graphite, or Lip-seal and Graphite in all static body joint components ensures Zero leakage and Fire Safe features. Other special gaskets can be used for special service.

Trunnion Mounted Ball

The Trunnion mounted ball design allows for ease of operation to minimize the operating torque and to reduce seat seal wear.

The ball is fixed and the seats are floating which allows freedom for the ball to move along the valve axis. The pressure from the fluid pushes the seat against the ball. At low pressure, the seat sealing action is achieved by force of the springs acting on the floating seats.

Anti-Static Device

The Anti-Static Device allows for electrical continuity between all valve components.

Fire Safe

The valves are designed to ensure all functionality in case of fire.

Stem Feature

Valves shall be designed to ensure that the stem does not eject under any internal pressure condition or of the packing gland components and/or valve operator mounting components are removed. The Anti-Blowout

stem permits the replacement of the stem seals with the valve in the fully Open or Closed position. The stem seal integrity is achieved by using special gaskets (PTFE or Graphite Packing, O-Ring, Lip-seal or other design available on request).

Emergency Stem & Seats seals

An emergency sealant injection system is available upon request, which can restore the sealing integrity if damage is caused to sealing surface or gaskets.

Seats Feature

The two independent seats assure the bi-directional tightness of the valve.

The floating seats are spring-loaded and are always in contact with the ball to provide an effective seal and even allows for differential pressure. When the pressure is simultaneously applied to both sides of the ball in either fully open or fully closed positions, the body cavity is isolated from upstream and downstream sides, allowing the Double Block and Bleed (DBB) feature. Fluid pressure acting in the body cavity creates a resultant thrust that pushes the seat away from the ball. The seat design permits the automatic relief of any overpressure in the body cavity when the valve is in fully open or fully closed position (Self relieving seats).

Low Emission

Accurate machining of Stem and other sealing surfaces ensure compliance with the most severe pollution-control regulations.

Trunnion split body (SB), fully welded (FW) & top entry (TE)

Size	CLASS	150			300			600			900			1500			2500			
inches	Design	SB	FW	TE	SB	FW	TE	SB	FW	TE	SB	FW	TE	SB	FW	TE	SB	FW	TE	
2	FB																			
	RB																			
3	FB																			
	RB																			
4	FB																			
	RB																			
6	FB																			
	RB																			
8	FB																			
	RB																			
10	FB																			
	RB																			
12	FB																			
	RB																			
14	FB																			
	RB																			
16	FB																			
	RB																			
18	FB																			
	RB																			
20	FB																			
	RB																			
22	FB																			
	RB																			
24	FB																			
	RB																			
26	FB																			
	RB																			
28	FB																			
	RB																			
30	FB																			
	RB																			
32	FB																			
	RB																			
34	FB																			
	RB																			
36	FB																			
	RB																			
40	FB																			
	RB																			
42	FB																			
	RB																			
48	FB																			
	RB																			
56	FB																			
	RB																			

Floating ball valves

Size	CLASS	150	300	600	900	1500	2500
inches	Design	SB	SB	SB	SB	SB	SB
1/2	FB						
	RB						
3/4	FB						
	RB						
1	FB						
	RB						
1 1/2	FB						
	RB						
2	FB						
	RB						
3	FB						
	RB						
4	FB						
	RB						
6	FB						
	RB						

API 6A ball valves

Size	CLASS			
inches	2000	3000	5000	10000
1 13/16				
2 1/16				
2 9/16				
3 1/16				
3 1/8				
4 1/16				
5 1/8				
7 1/16				

3 WAY BALL VALVES



FULLY WELDED



MODULAR DBB BALL VALVES



TOP ENTRY



CRYOGENIC BALL VALVES



SUBSEA



API 6A (10K)



In our production range you can also find: High Temp Valves (Metal to Metal), Valves for Oxygen Service and Actuated Valves.



TIV VALVES ball valves are designed and manufactured in accordance with all applicable international standards and according to customer specifications and requirements. All ball valves are tested according to API 6D standard and supplied with certified hydrostatic pressure test reports including the material test reports of pressure containing parts. Applicable standards:

API 6D, API 6A, API 6FA, API 607, API 598, API 605

ASME B16.5, ASME B16.10, ASME B16.25, ASME B16.34,

ASME B31.3, ASME B31.8, ASME B46.1

MSS SP - 6, MSS SP - 25, MSS SP - 44, MSS SP - 45, MSS SP -55

ISO 10497, ISO 15848, ISO 17292, ISO 5208, ISO 9001

BS 6364, EN 12266 - 1, EN 12266 - 2, EN ISO 17292, EN 14141,

EN 473/ISO 9712, PED (97/23/CE), ATEX (94/9/CE)

NACE MR 0175 – ISO 15156, NACE MR 0103

- Type acceptance test (TAT 77/300)
- Oxygen room
- Fugitive Emissions
- Performance and Functionality
- High Pressure Gas
- High Temperature
- Low Temperature
- Fire Safe
- NDE Inspections



Floating ball

PART LIST

Pos.	Part name
1	BODY
2	CLOSURE
3	BALL
4	STEM
5	SEAT
8	GLAND RING
18	SPRING WASHER
20,21	SEAL
30	GASKET
35	PACKING
40	STUD BOLT
41,45	NUT
57	WASHER
72	PIN
80	LEVER

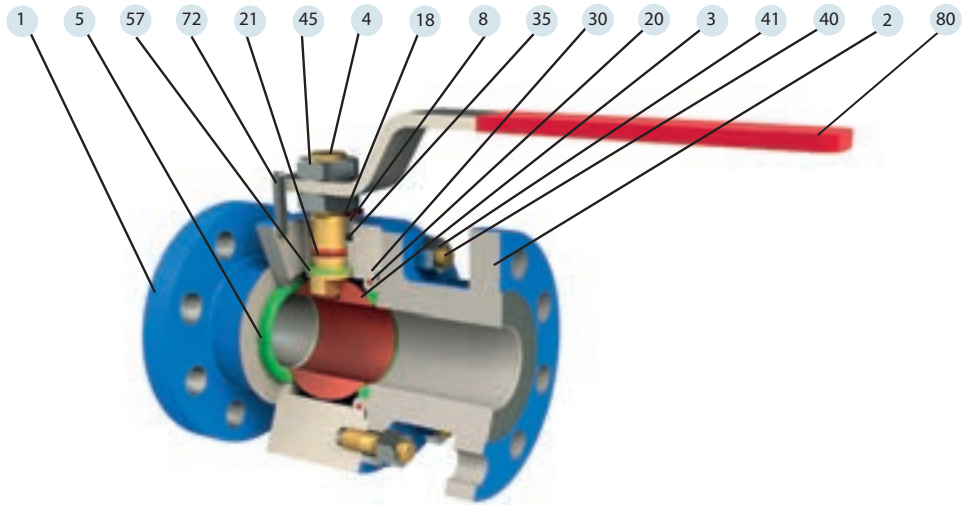

Trunnion - 2 piece split body 4" & smaller

PART LIST

Pos.	Part name
1	BODY
2	CLOSURE
3	BALL
4	STEM
5	SEAT RING
7	TRUNNION
8	GLAND
9	ADAPTER FLANGE
20,21,22,23	SEAL
30,31,32	GASKET
35	PACKING
40	STUD BOLT
41	NUT
42,43,44	CAP SCREW
51,52	BEARING
57	WASHER
60	KEY

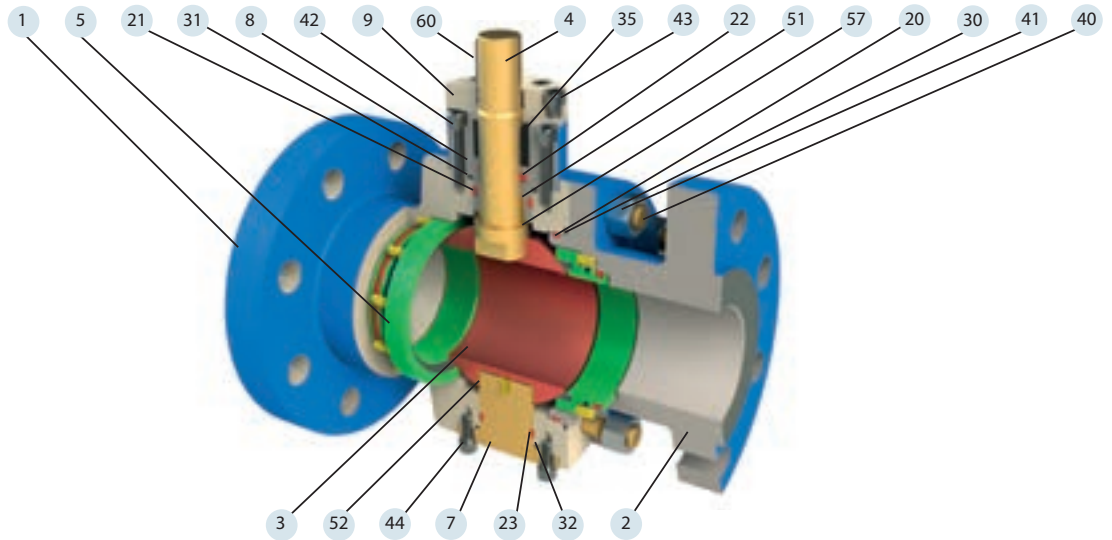

Trunnion - 3 piece split body 6" & larger

PART LIST

Pos.	Part name
1	BODY
2	CLOSURE
3	BALL
4	STEM
5	SEAT RING
6	TRUNNION PLATE
8	GLAND
9	ADAPTER FLANGE
20,21,22	SEAL
30,31	GASKET
35	PACKING
40	STUD BOLT
41	NUT
42,43	CAP SCREW
50,51	BEARING
56,57	WASHER
60	KEY
70,71	PIN

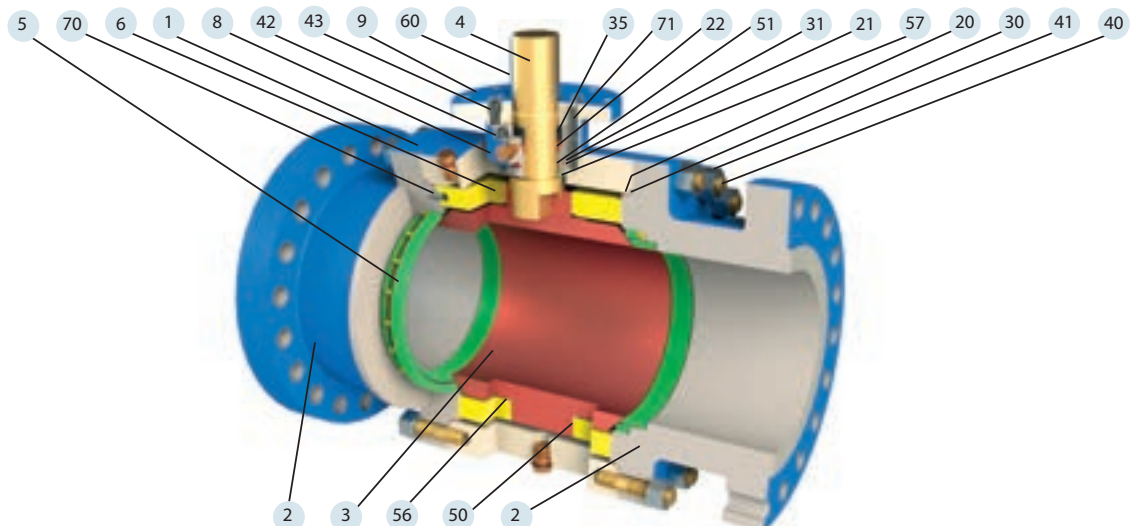

BALL VALVE STANDARD DESIGN



Trunnion - Fully welded body

PART LIST

Pos.	Part name
1	BODY
2	CLOSURE
3	BALL
4	STEM
5	SEAT RING
6	TRUNNION PLATE
8	GLAND
9	ADAPTER FLANGE
21,22	SEAL
31	GASKET
35	PACKING
42,43	CAP SCREW
50,51	BEARING
56,57	WASHER
60	KEY
70,71	PIN

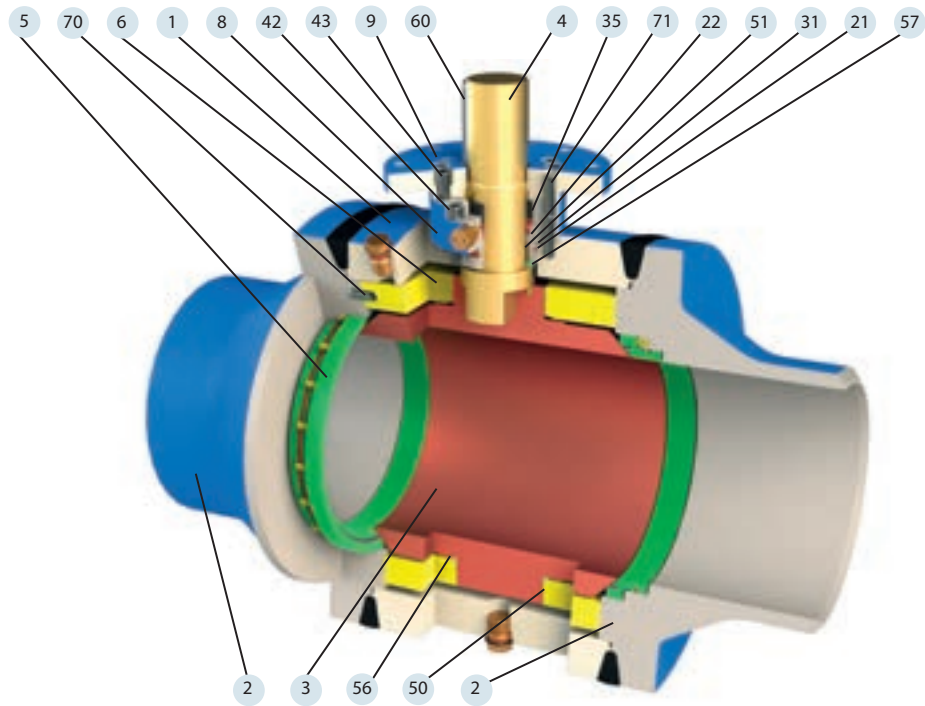

Trunnion - Top entry

PART LIST

Pos.	Part name
1	BODY
2	COVER
3	BALL
4	STEM
5	SEAT RING
8	GLAND
9	ADAPTER FLANGE
20,21,22	SEAL
30,31	GASKET
35	PACKING
40	STUD BOLT
41	NUT
42,43	CAP SCREW
50,51	BEARING
56,57	WASHER
60	KEY
71	PIN

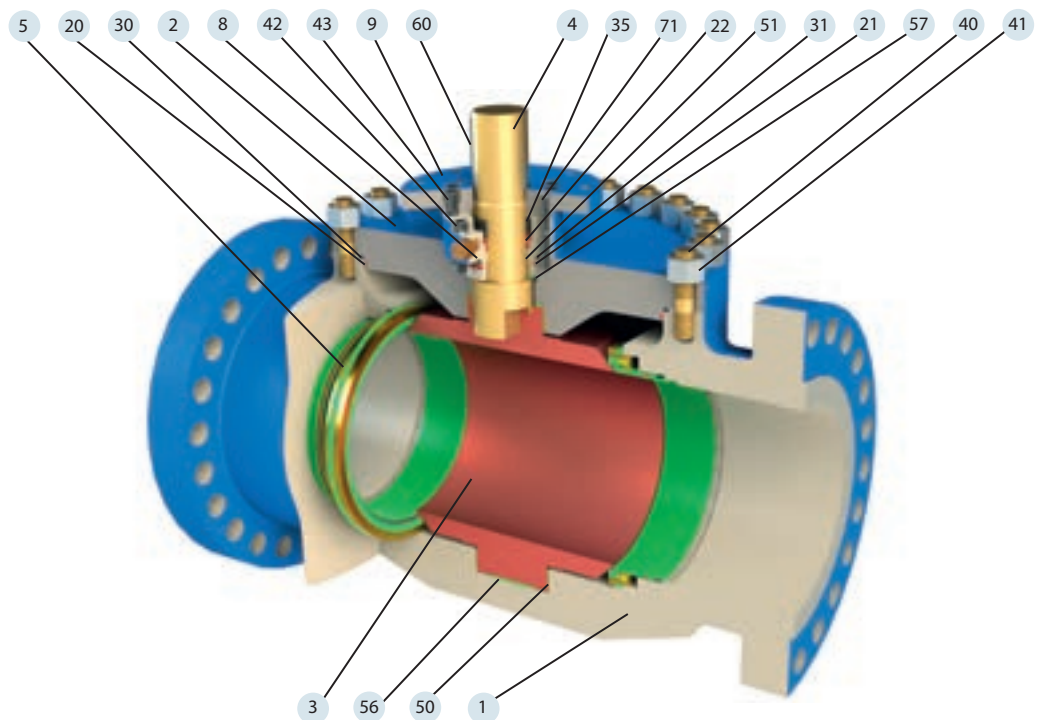

Blow – Out Proof Stem

The Ball valves stem is an anti-blow-out design. This anti-blow-out stem permits the replacement of the stem seals with the valve in the fully open or closed position.

Body Joint Sealing

The double sealing action of O – Ring and Graphite, or Lip – seal and Graphite in all static body joint components ensures zero leakage and Fire Safe features. Other special gaskets can be used for special service.

Anti-Static Device

The Anti – Static Device allows electrical continuity between all valve components.

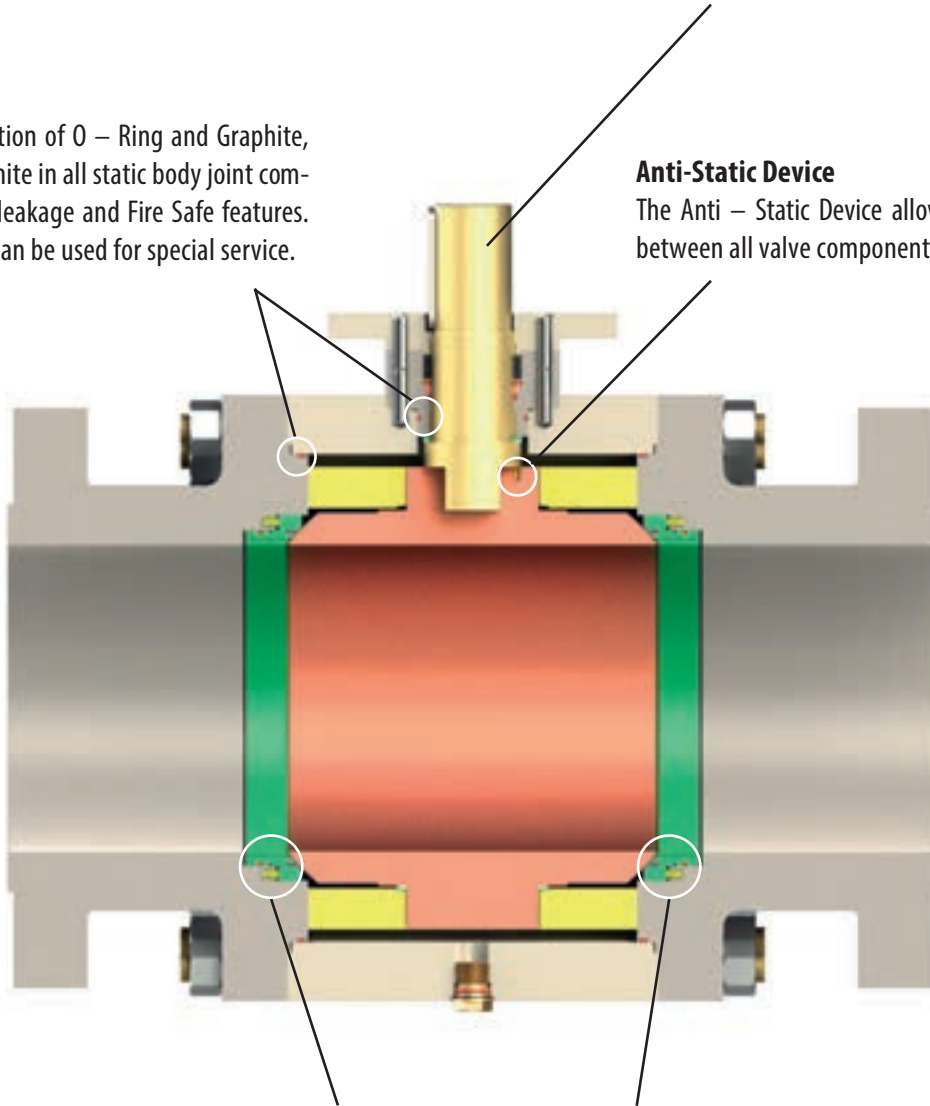

Seats Feature

The two independent seats assure the bi – directional tightness of the valve. The floating seats are spring – loaded and are always in contact with the ball to provide an effective seal and even allows for differential pressure. When the pressure is simultaneously applied to both sides of the ball in either fully open or fully closed positions, the body cavity is isolated from upstream and downstream sides, allowing the Double Block and Bleed (DBB) feature. Fluid pressure acting in the body cavity creates resultant thrust that pushes seats away from the ball. The seats design permits the automatic relief of any overpressure in the body cavity when the valve is in fully open or fully closed position (Self relieving seats).

Fire Safe

The valves are designed to ensure all functionality in case of fire.

Low Emission

Accurate machining of stem and other sealing surfaces ensures compliance with the most severe pollution – control regulations.

Extended bonnet

Extended bonnet ball valves for extreme temperature application available on request.

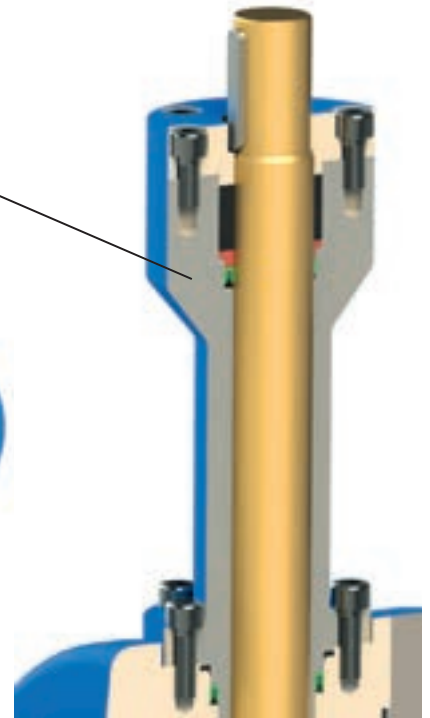
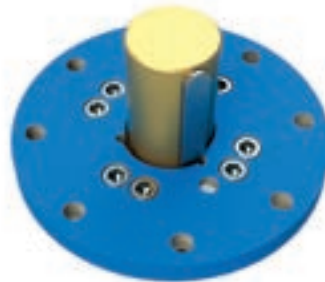

Alignment of ball seat

Ball rotation control is ensured by mechanical stops.

Pressure – Temperature rating chart for seat seal materials

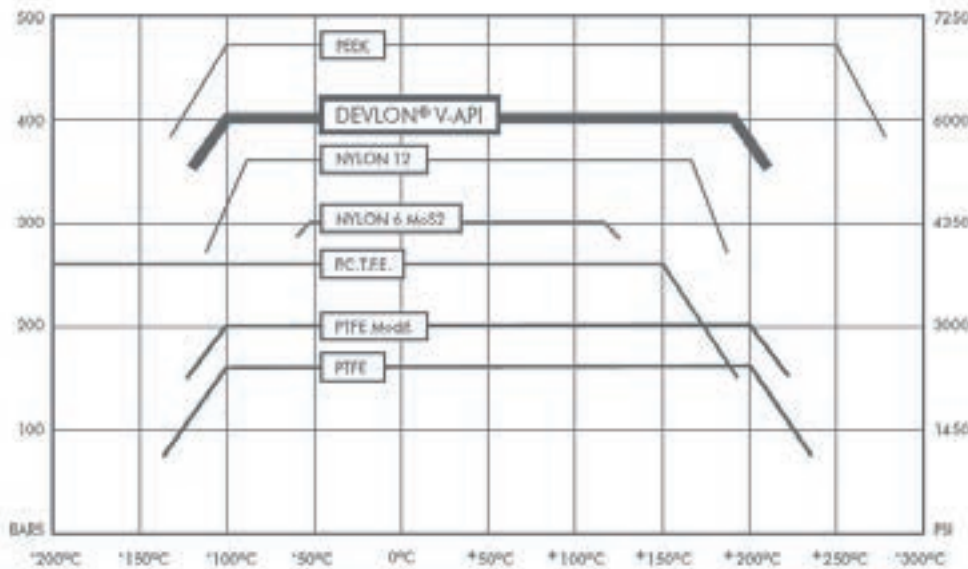

SEAT DESIGN

The seat insert material selection depends on the application – pressure, temperature, type of fluid etc.

The metal to metal seats are selected in case of application with corrosive or abrasive fluids together with high temperature and pressure. The seat rings are hard faced with Electroless Nickel, Chrome Carbide, Tungsten Carbide or Stellite.

Primary thermoplastic insert (soft seal)

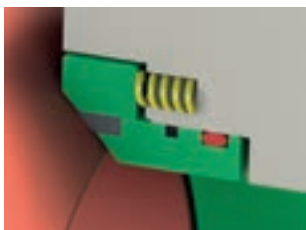

Primary elastomeric insert (soft seal)

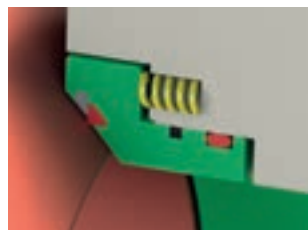

Primary metal insert & secondary soft (metal seal)

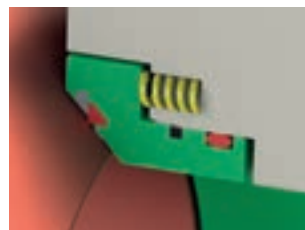

Primary metal (metal seal)

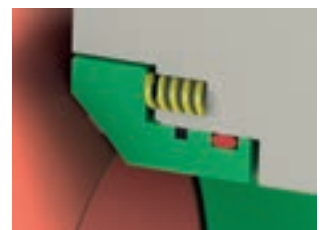

CARBON STEEL

Pos.	Part name	Material specification			
1	BODY	ASTM A105	ASTM A105	ASTM A105	ASTM A105
2	CLOSURE	ASTM A105	ASTM A105	ASTM A105	ASTM A105
3	BALL	ASTM A105 + ENP	ASTM A182 F316	ASTM A105 + ENP	ASTM A182 F316
4	STEM	AISI 4140 + ENP	UNS S31803 / S17400	AISI 4140 + ENP	UNS S31803 / S17400
5	SEAT RING	ASTM A105 + ENP	ASTM A182 F316	ASTM A105 + ENP	ASTM A182 F316
6	COVER	ASTM A105	ASTM A105	ASTM A105	ASTM A105
7	TRUNNION	ASTM A105	ASTM A105	ASTM A105	ASTM A105
8	BODY BOLT	ASTM A193 B7	ASTM A193 B7	ASTM A193 B7M	ASTM A193 B7M
9	BODY NUT	ASTM A194 2H	ASTM A194 2H	ASTM A194 2HM	ASTM A194 2HM

LOW TEMPERATURE CARBON STEEL

Pos.	Part name	Material specification			
1	BODY	ASTM A350 LF2	ASTM A350 LF2	ASTM A350 LF2	ASTM A350 LF2
2	CLOSURE	ASTM A350 LF2	ASTM A350 LF2	ASTM A350 LF2	ASTM A350 LF2
3	BALL	ASTM A350 LF2 + ENP	ASTM A182 F316	ASTM A350 LF2 + ENP	ASTM A182 F316
4	STEM	AISI 4140 + ENP	UNS S31803 / S17400	AISI 4140 + ENP	UNS S31803 / S17400
5	SEAT RING	ASTM A350 LF2 + ENP	ASTM A182 F316	ASTM A350 LF2 + ENP	ASTM A182 F316
6	COVER	ASTM A350 LF2	ASTM A350 LF2	ASTM A350 LF2	ASTM A350 LF2
7	TRUNNION	ASTM A350 LF2	ASTM A350 LF2	ASTM A350 LF2	ASTM A350 LF2
8	BODY BOLT	ASTM A320 L7	ASTM A320 L7	ASTM A320 L7M	ASTM A320 L7M
9	BODY NUT	ASTM A194 Gr. 7	ASTM A194 Gr. 7	ASTM A194 Gr. 7M	ASTM A194 Gr. 7M

LOW ALLOY STEEL

Pos.	Part name	Material specification			
1	BODY	ASTM A694 F52 / F60	ASTM A694 F52 / F60	AISI 4130 / AISI 4140	AISI 4130 / AISI 4140
2	CLOSURE	ASTM A694 F52 / F60	ASTM A694 F52 / F60	AISI 4130 / AISI 4140	AISI 4130 / AISI 4140
3	BALL	ASTM A694 F60 + ENP	ASTM A182 F51	AISI 4140 + ENP	UNS S17400
4	STEM	AISI 4140 + ENP	UNS S31803 / S20910	AISI 4140 + ENP	UNS S17400
5	SEAT RING	ASTM A694 F60 + ENP	ASTM A182 F51	AISI 4140 + ENP	UNS S17400
6	COVER	ASTM A694 F52 / F60	ASTM A694 F52 / F60	AISI 4130 / AISI 4140	AISI 4130 / AISI 4140
7	TRUNNION	ASTM A694 F52 / F60	ASTM A694 F52 / F60	AISI 4130 / AISI 4140	AISI 4130 / AISI 4140
8	BODY BOLT	ASTM A193 B7	ASTM A193 B7M	ASTM A193 B7	ASTM A193 B7
9	BODY NUT	ASTM A194 2H	ASTM A194 2HM	ASTM A194 2H	ASTM A194 2H

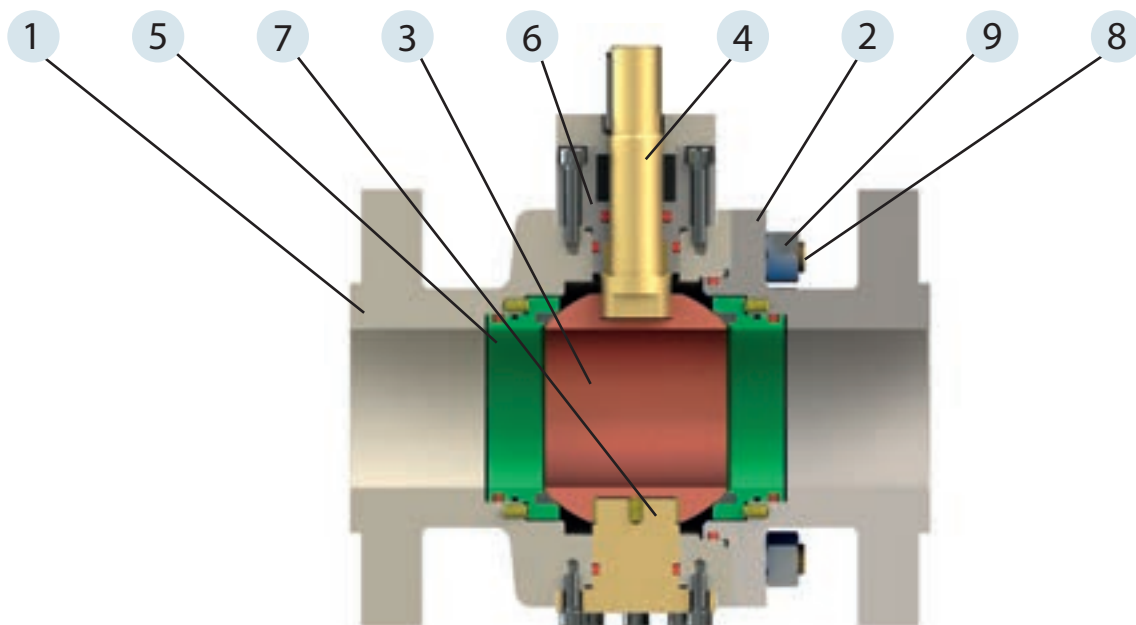

OVERALL DIMENSIONS & WEIGHT



Trunnion mounted ball valves

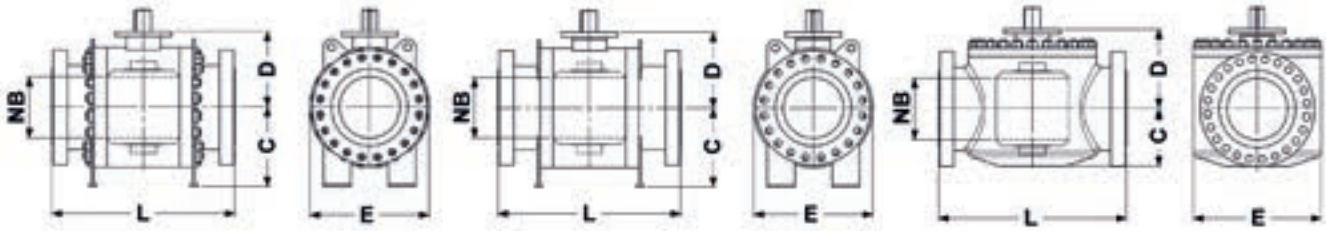

CLASS 150 FULL BORE

SIZE		SPLIT BODY						FULLY WELDED BODY						TOP ENTRY					
inches	NB	L RF	L BW	C	D	E	WEIGHT (kg)	L RF	L BW	C	D	E	WEIGHT (kg)	L RF	L BW	C	D	E	WEIGHT (kg)
2	49	178	216	110	120	152	26	178	216	110	120	152	25	292	292	85	207	180	30
3	74	203	283	135	150	191	42	203	283	135	150	191	40	356	356	114	223	230	57
4	100	229	305	165	165	229	63	229	305	165	165	229	58	432	432	140	280	282	100
6	150	394	457	275	235	285	165	394	457	275	235	285	145	559	559	219	275	323	215
8	201	457	521	325	295	345	250	457	521	325	295	345	245	660	660	265	321	405	407
10	252	533	559	365	335	410	385	533	559	365	335	410	320	787	787	315	355	490	560
12	303	610	635	405	375	485	562	610	635	405	375	485	540	838	838	405	470	565	710
14	334	686	762	415	425	535	765	686	762	415	425	535	720	889	889	432	455	660	760
16	385	762	838	475	465	600	1030	762	838	475	465	600	1000	991	991	451	460	700	1100
18	436	864	914	490	480	715	1420	864	914	490	480	715	1300	1092	1092	472	503	747	1512
20	487	914	991	520	490	840	1810	914	991	520	490	840	1750	1194	1194	560	560	849	1930
22	538	991	1092	572	530	930	2390	991	1092	572	530	930	2150	1296	1296	591	565	935	2750
24	589	1067	1143	630	580	995	3130	1067	1143	630	580	995	2860	1397	1397	600	610	1005	3200
26	633	1143	1245	680	620	1050	3710	1143	1245	680	620	1050	3500	1448	1448	632	670	1066	3800
28	684	1245	1346	780	640	1130	4590	1244	1346	780	640	1130	4250	1549	1549	710	730	1136	4600
30	735	1295	1397	830	695	1190	5180	1295	1397	830	695	1190	5000	1651	1651	790	800	1259	5630
32	779	1372	1524	860	740	1280	6650	1372	1524	860	740	1280	5650	1778	1778	830	846	1300	7085
34	830	1473	1626	890	770	1350	7890	1473	1626	890	770	1350	6500	1930	1930	880	870	1400	7800
36	874	1524	1727	930	820	1410	8450	1524	1727	930	820	1410	8050	2083	2083	933	935	1438	9100
40	976	1753	1956	1010	910	1615	11300	1753	1956	1010	910	1615	10700	2337	2337	1030	1012	1650	12790
42	1020	1790	2083	1050	980	1705	13500	1790	2083	1050	980	1705	12400	2437	2437	1065	1070	1700	15100
48	1166	1995	2388	1190	1135	1960	19100	1995	2388	1190	1135	1960	17100	2540	2540	1230	1190	1950	22600
56	1360	2489	2489	1290	1290	2280	29100	2489	2489	1290	1290	2280	26300						

CLASS 150 REDUCED BORE

SIZE		SPLIT BODY						FULLY WELDED BODY						TOP ENTRY					
inches	NB	L RF	L BW	C	D	E	WEIGHT (kg)	L RF	L BW	C	D	E	WEIGHT (kg)	L RF	L BW	C	D	E	WEIGHT (kg)
2x1,5	38	178	216	90	100	152	24	178	216	90	100	152	20	292	292	85	207	175	25
3x2	49	203	283	100	120	191	38	203	283	100	120	191	30	356	356	87	210	191	34
4x3	74	229	305	125	150	228	55	229	305	125	150	228	50	432	432	110	225	230	70
6x4	100	394	457	155	165	279	89	394	457	155	165	279	80	559	559	143	270	279	130
8x6	150	457	521	315	235	330	190	457	521	315	235	330	170	660	660	215	275	343	250
10x8	201	533	559	340	295	390	295	533	559	340	295	390	250	787	787	262	320	406	455
12x10	252	610	635	390	335	480	470	610	635	390	335	480	420	838	838	310	355	485	485
14x10	252	686	762	405	335	535	530	686	762	405	335	535	480	889	889	310	355	535	665
14x12	303	686	762	405	375	535	620	686	762	405	375	535	570	889	889	395	475	535	790
16x12	303	762	838	450	375	595	705	762	838	450	375	595	650	991	991	395	475	595	940
16x14	334	762	838	450	425	595	835	762	838	450	425	595	740	991	991	430	450	660	908
18x16	385	864	914	480	465	635	1080	864	914	480	465	635	980	1092	1092	450	460	700	1248
20x16	385	914	991	510	465	700	1280	914	991	510	465	700	1150	1194	1194	450	460	700	1542
20x18	436	914	991	540	480	700	1430	914	991	540	480	700	1300	1194	1194	470	495	745	1740
24x20	487	1067	1143	610	490	815	2100	1067	1143	610	490	815	1850	1397	1397	580	550	870	2378
30x24	589	1295	1397	670	580	985	3430	1295	1397	670	580	985	3100	1651	1651	592	590	1020	4008
36x30	874	1524	1727	740	695	1170	6430	1524	1727	740	695	1170	6000	2083	2083	765	795	1250	7048

Design, weights and dimensions not established by International Standards are subject to change without notice.

Dimensions in mm

Trunnion mounted ball valves

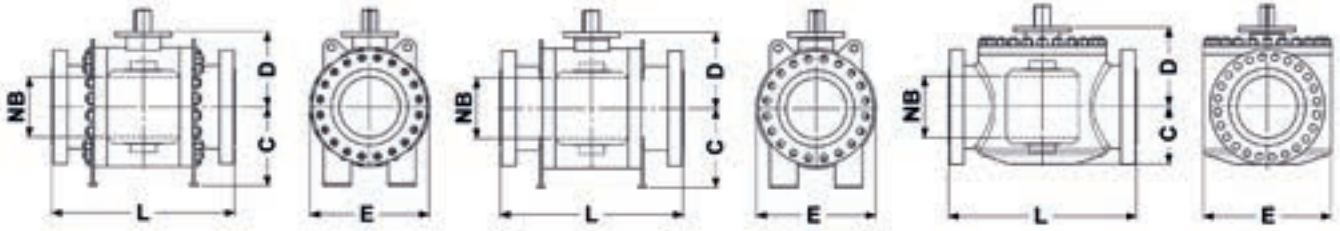

CLASS 300 FULL BORE

SIZE		SPLIT BODY						FULLY WELDED BODY						TOP ENTRY					
inches	NB	L RF	L BW	C	D	E	WEIGHT (kg)	L RF	L BW	C	D	E	WEIGHT (kg)	L RF	L BW	C	D	E	WEIGHT (kg)
2	49	216	216	110	120	165	31	216	216	110	120	165	28	292	292	90	211	185	36
3	74	283	283	135	150	210	54	283	283	135	150	210	50	356	356	119	226	235	63
4	100	305	305	165	165	254	72	305	305	165	165	254	65	432	432	145	286	287	106
6	150	403	457	275	235	318	187	403	457	275	235	318	170	559	559	224	282	330	221
8	201	502	521	325	295	381	290	502	521	325	295	381	250	660	660	270	325	410	412
10	252	568	559	365	335	445	510	568	559	365	335	445	450	787	787	320	360	500	566
12	303	648	635	405	375	521	740	648	635	405	375	521	670	838	838	410	475	570	715
14	334	762	762	415	425	584	1040	762	762	415	425	584	950	889	889	437	460	665	766
16	385	838	838	475	465	648	1430	838	838	475	465	648	1320	991	991	456	465	707	1106
18	436	914	914	490	480	750	1720	914	914	490	480	750	1580	1092	1092	477	508	752	1519
20	487	991	991	520	505	830	2250	991	991	520	505	830	2045	1194	1194	565	565	855	1936
22	538	1092	1092	540	530	915	2910	1092	1092	540	530	915	2630	1296	1296	596	572	942	2756
24	589	1143	1143	585	600	995	3520	1143	1143	585	600	995	3120	1397	1397	605	617	1010	3208
26	633	1245	1245	610	635	1030	4750	1245	1245	610	635	1030	4350	1448	1448	637	687	1072	3808
28	684	1346	1346	695	650	1130	5820	1346	1346	695	650	1130	5500	1549	1549	715	738	1141	4607
30	735	1397	1397	750	690	1205	6450	1397	1397	750	690	1205	6100	1651	1651	795	811	1265	5638
32	779	1524	1524	790	750	1285	8050	1524	1524	790	750	1285	7620	1778	1778	835	850	1312	7092
34	830	1626	1626	830	780	1330	9120	1626	1626	830	780	1330	8500	1930	1930	885	877	1408	7811
36	874	1727	1727	850	810	1410	10200	1727	1727	850	810	1410	10000	2083	2083	938	942	1445	9112
40	975	1956	1956	1010	910	1620	11800	1956	1956	1010	910	1620	11100	2337	2337	1036	1020	1663	12790
42	1020	2083	2083	1050	980	1715	14100	2083	2083	1050	1050	1715	12900	2437	2437	1070	1081	1715	15100
48	1166	2170	2170	1190	1135	1985	20200	2170	2170	1190	1190	1985	17800	2540	2540	1236	1201	1965	22700
56	1360	2743	2743	1350	1290	2305	30700	2743	2743	1350	1350	2303	27200						

CLASS 300 REDUCED BORE

SIZE		SPLIT BODY						FULLY WELDED BODY						TOP ENTRY					
inches	NB	L RF	L BW	C	D	E	WEIGHT (kg)	L RF	L BW	C	D	E	WEIGHT (kg)	L RF	L BW	C	D	E	WEIGHT (kg)
2x1,5	38	216	216	90	110	165	27	216	216	90	110	165	25	292	292	80	206	178	26
3x2	49	283	283	110	120	210	51	283	283	110	120	210	45	356	356	90	211	210	42
4x3	74	305	305	135	150	254	65	305	305	135	150	254	57	432	432	119	226	254	82
6x4	100	403	457	165	165	318	98	403	457	165	165	318	88	559	559	145	286	318	161
8x6	150	502	521	280	235	381	230	502	521	280	235	381	200	660	660	224	282	381	285
10x8	201	568	559	300	325	445	295	568	559	300	325	445	250	787	787	270	325	445	536
12x10	252	648	635	360	335	521	620	648	635	360	335	521	580	838	838	320	360	520	572
14x10	252	762	762	360	335	584	660	762	762	360	335	584	615	889	889	320	360	520	781
14x12	303	762	762	380	375	584	830	762	762	380	375	584	780	889	889	410	475	585	916
16x12	303	838	838	380	375	648	990	838	838	380	375	648	910	991	991	410	475	650	1092
16x14	334	838	838	435	425	648	1150	838	838	435	425	648	1075	991	991	437	460	665	1095
18x16	385	914	914	475	465	715	1650	914	914	475	465	715	1550	1092	1092	456	465	710	1462
20x16	385	991	991	475	465	780	1750	991	991	475	465	780	1650	1194	1194	456	465	775	1809
20x18	436	991	991	490	480	780	1820	991	991	490	480	780	1720	1194	1194	477	508	775	2023
24x20	487	1143	1143	540	505	920	2750	1143	1143	540	505	920	2590	1397	1397	565	565	915	2774
30x24	589	1626	1626	590	600	1100	4520	1626	1626	590	600	1100	4450	1651	1651	605	617	1090	4665
36x30	735	1727	1727	700	690	1290	8200	1727	1727	700	690	1290	8000	2083	2083	795	811	1270	8298

Design, weights and dimensions not established by International Standards are subject to change without notice.

Dimensions in mm

OVERALL DIMENSIONS & WEIGHT



Trunnion mounted ball valves

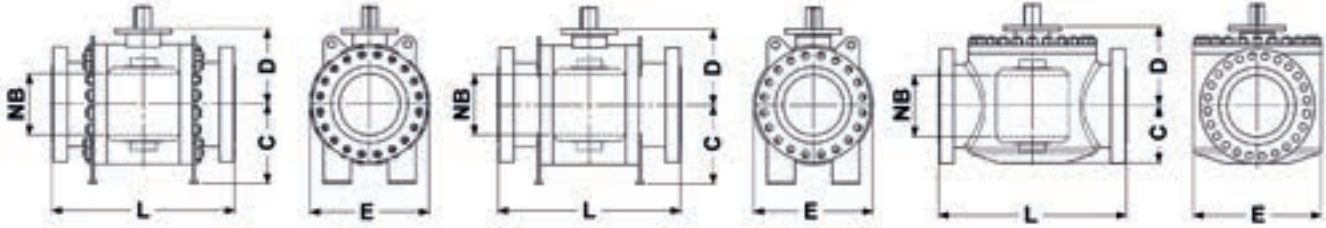

CLASS 600 FULL BORE

SIZE		SPLIT BODY							FULLY WELDED BODY							TOP ENTRY						
inches	NB	L RF	L RTJ	L BW	C	D	E	WEIGHT (kg)	L RF	L RTJ	L BW	C	D	E	WEIGHT (kg)	L RF	L RTJ	L BW	C	D	E	WEIGHT (kg)
2	49	292	295	292	110	120	165	35	292	295	292	110	120	165	32	292	295	292	95	215	190	41
3	74	356	359	356	135	150	210	65	356	359	356	135	150	210	60	356	359	356	124	232	240	67
4	100	432	435	432	165	165	273	94	432	435	432	165	165	273	85	432	435	432	150	294	290	110
6	150	559	562	559	290	245	356	260	559	562	559	290	245	356	240	559	562	559	129	287	335	226
8	201	660	664	660	340	310	419	490	660	664	660	340	310	419	440	660	664	660	275	324	415	417
10	252	787	791	787	380	340	508	780	787	791	787	380	340	508	720	787	791	787	325	365	505	570
12	303	838	841	838	420	400	559	1010	838	841	838	420	400	559	950	838	841	838	415	480	575	720
14	334	889	892	889	460	440	603	1190	889	892	889	460	440	603	1100	889	892	889	442	465	670	770
16	385	991	994	991	490	475	686	1580	991	994	991	490	475	686	1450	991	994	991	461	470	712	1112
18	436	1092	1095	1092	520	490	780	2120	1092	1095	1092	520	490	780	2000	1092	1095	1092	482	512	757	1523
20	487	1194	1200	1194	540	510	870	2680	1194	1200	1194	540	510	870	2550	1194	1200	1194	570	570	860	1940
22	538	1295	1305	1295	570	550	950	3960	1295	1305	1295	570	550	950	3700	1295	1305	1295	602	578	947	2760
24	589	1397	1407	1397	590	600	1030	5020	1397	1407	1397	590	600	1030	4550	1397	1406	1397	610	622	1015	3213
26	633	1445	1461	1445	630	635	1090	5890	1445	1461	1445	630	635	1090	5700	1445	1460	1445	640	682	1078	3813
28	684	1549	1562	1549	700	660	1150	6850	1549	1562	1549	700	660	1150	6500	1549	1562	1549	722	742	1146	4612
30	735	1651	1664	1651	790	740	1300	8450	1651	1664	1651	790	740	1300	8100	1651	1697	1651	804	817	1270	5640
32	779	1778	1794	1778	840	760	1350	9780	1778	1794	1778	840	760	1350	9500	1778	1794	1778	840	855	1317	7103
34	830	1930	1946	1930	870	780	1400	11450	1930	1946	1930	870	780	1400	10800	1930	1946	1930	890	893	1423	7822
36	874	2083	2099	2083	950	860	1550	13480	2083	2099	2083	950	860	1550	12500	2083	2098	2083	944	947	1450	9118
40	976	2080	2170	2170	1035	935	1660	15150	2080	2170	2170	1035	935	1660	14300	2170	2170	2170	1041	1025	1668	12805
42	1020	2175	2175	2175	1075	995	1755	17900	2175	2175	2175	1075	995	1755	16600	2175	2175	2175	1075	1086	1720	15118
48	1166	2435	2435	2435	1220	1160	2020	25050	2435	2435	2435	1220	1160	2020	22500	2435	2435	2435	1240	1506	1970	22619
56	1360	2710	2710	2710	1385	1310	2340	37900	2710	2710	2710	1385	1310	2340	34200							

CLASS 600 REDUCED BORE

SIZE		SPLIT BODY							FULLY WELDED BODY							TOP ENTRY						
inches	NB	L RF	L RTJ	L BW	C	D	E	WEIGHT (kg)	L RF	L RTJ	L BW	C	D	E	WEIGHT (kg)	L RF	L RTJ	L BW	C	D	E	WEIGHT (kg)
2x1.5	38	292	295	292	90	100	165	30	292	295	292	90	100	165	30	368	295	368	85	210	178	34
3x2	49	356	359	356	110	110	210	60	356	359	356	110	110	210	60	356	359	356	95	215	210	46
4x3	74	432	435	432	135	135	273	88	432	435	432	135	135	273	88	432	436	432	124	232	273	94
6x4	100	559	562	559	165	165	353	165	559	562	559	165	165	353	165	559	562	559	150	294	356	82
8x6	150	559	562	559	300	245	419	310	559	562	559	300	245	419	310	660	664	660	129	287	419	318
10x8	201	787	664	787	350	310	508	580	787	664	787	350	310	508	580	787	791	787	275	324	510	600
12x10	252	838	791	838	390	340	559	830	838	791	838	390	340	559	830	838	841	838	325	365	560	720
14x10	252	889	791	889	390	340	603	930	889	791	889	390	340	603	930	889	892	889	325	365	605	990
14x12	303	889	892	889	430	400	603	1160	889	892	889	430	400	603	1160	889	892	889	415	480	605	1190
16x12	303	991	841	991	430	400	686	1410	991	841	991	430	400	686	1410	991	994	991	415	480	685	1400
16x14	334	991	892	991	465	440	686	1560	991	892	991	465	440	686	1560	991	994	991	442	465	685	1380
18x16	385	1092	994	1092	500	475	750	1780	1092	994	1092	500	475	750	1780	1092	1095	1092	461	470	745	1860
20x16	385	1194	994	1194	500	475	815	2040	1194	994	1194	500	475	815	2040	1194	1200	1194	461	470	815	2900
20x18	436	1194	1095	1194	525	490	815	2390	1194	1095	1194	525	490	815	2390	1194	1200	1194	482	512	815	2600
24x20	487	1397	1200	1397	550	510	940	3280	1397	1200	1397	550	510	940	3280	1397	1406	1397	570	570	940	3500
28x24	589	1549	1562	1549	600	600	1150	5690	1549	1562	1549	600	600	1150	5690							
30x24	589	1651	1664	1651	600	600	1150	7100	1651	1664	1651	600	600	1150	7100	1684	1697	1684	610	622	1130	5950
32x26	633	1778	1794	1778	630	635	1250	8350	1778	1794	1778	630	635	1250	8350							
36x30	735	2083	2099	2083	800	740	1320	10520	2083	2099	2083	800	740	1320	10520	2083	2098	2083	804	817	1315	10600

Design, weights and dimensions not established by International Standards are subject to change without notice.

Dimensions in mm

Trunnion mounted ball valves

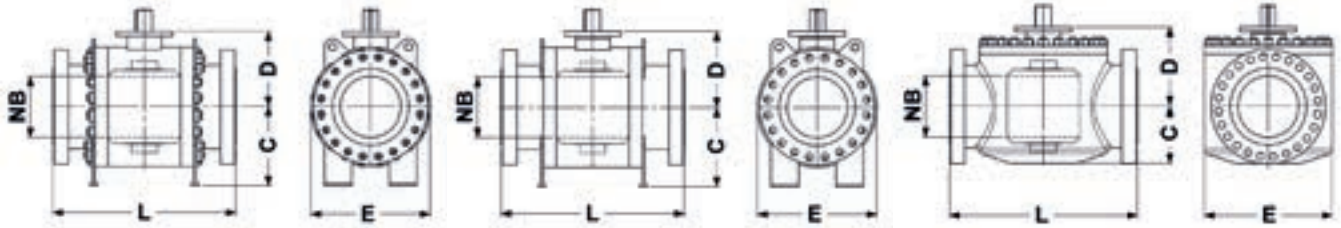

CLASS 900 FULL BORE

SIZE		SPLIT BODY							FULLY WELDED BODY							TOP ENTRY						
inches	NB	L RF	L RTJ	L BW	C	D	E	WEIGHT (kg)	L RF	L RTJ	L BW	C	D	E	WEIGHT (kg)	L RF	L RTJ	L BW	C	D	E	WEIGHT (kg)
2	49	368	371	368	110	135	212	60	368	371	368	110	135	212	55	368	371	368	85	212	216	52
3	74	381	384	381	145	155	241	82	381	384	381	145	155	241	75	381	384	381	113	227	241	110
4	100	457	460	457	170	175	292	128	457	460	457	170	175	292	105	457	460	457	144	277	292	200
6	150	610	613	610	300	245	381	380	610	613	610	300	245	381	350	610	613	610	333	283	381	430
8	201	737	740	737	350	310	470	620	737	740	737	350	310	470	550	737	740	737	274	334	470	800
10	252	838	841	838	390	345	546	1060	838	841	838	390	345	546	980	838	841	838	320	380	545	1000
12	303	965	968	965	440	420	610	1480	965	968	965	440	420	610	1400	965	968	965	418	507	610	1300
14	322	1029	1038	1029	450	440	640	1610	1029	1038	1029	450	440	640	1520	1029	1038	1029	443	520	640	1700
16	373	1130	1140	1130	470	460	710	2220	1130	1140	1130	470	460	710	2100	1130	1140	1130	462	538	710	2550
18	423	1219	1232	1219	500	500	800	2940	1219	1232	1219	500	500	800	2750	1219	1232	1219	487	580	800	3400
20	471	1321	1334	1321	520	550	890	4250	1321	1334	1321	520	550	890	4000	1321	1333	1321	605	625	890	4400
24	570	1549	1568	1549	630	630	1060	7430	1549	1568	1549	630	630	1060	7040	1549	1568	1549	625	690	1059	7200
26	617	1651	1673	1651	700	650	1190	8940	1651	1673	1651	700	650	1190	8180	1651	1673	1651	660	740	1130	9100
30	712	1880	1902	1880	780	740	1310	12400	1880	1902	1880	780	740	1310	11500	1880	1902	1880	800	880	1300	12900
32	760	2032	2054	2032	820	790	1360	14200	2032	2054	2032	820	790	1360	13500	2032	2054	2032	870	938	1357	15950
36	855	2286	2315	2286	900	850	1550	19200	2286	2315	2286	900	850	1550	18000	2086	2315	2086	990	1050	1532	20500

CLASS 900 REDUCED BORE

SIZE		SPLIT BODY							FULLY WELDED BODY							TOP ENTRY						
inches	NB	L RF	L RTJ	L BW	C	D	E	WEIGHT (kg)	L RF	L RTJ	L BW	C	D	E	WEIGHT (kg)	L RF	L RTJ	L BW	C	D	E	WEIGHT (kg)
2x1,5	38	368	371	368	90	115	226	55	368	371	368	90	115	226	50	368	371	368	84	211	216	50
3x2	49	381	384	381	110	135	241	76	381	384	381	110	135	241	70	381	384	381	84	211	241	75
4x3	74	457	460	457	135	165	292	102	457	460	457	135	165	292	90	457	460	457	109	227	292	140
6x4	100	610	613	610	165	175	381	220	610	613	610	165	175	381	200	610	613	610	145	276	381	273
8x6	150	737	740	737	470	245	390	480	737	740	737	470	245	390	420	737	740	737	223	280	470	548
10x8	201	838	841	838	456	310	480	710	838	841	838	456	310	480	620	838	841	838	271	339	545	906
12x10	252	965	968	965	610	345	550	1210	965	968	965	610	345	550	1100	965	968	965	324	380	610	1090
14x10	252	1029	1038	1029	640	345	560	1260	1029	1038	1029	640	345	560	1150	1029	1038	1029	324	380	640	1495
14x12	303	1029	1038	1029	640	420	610	1650	1029	1038	1029	640	420	610	1500	1029	1038	1029	410	515	640	1800
16x12	303	1130	1140	1130	710	420	620	1760	1130	1140	1130	710	420	620	1600	1130	1140	1130	410	515	705	2000
16x14	322	1130	1140	1130	710	440	650	1780	1130	1140	1130	710	440	650	1670	1130	1140	1130	445	520	705	2100
18x16	373	1219	1232	1219	800	460	720	2480	1219	1232	1219	800	460	720	2100	1219	1232	1219	463	536	785	2800
20x16	373	1321	1334	1321	860	460	720	2940	1321	1334	1321	860	460	720	2500	1321	1333	1321	463	536	855	3500
20x18	423	1321	1334	1321	860	500	820	3260	1321	1334	1321	860	500	820	2840	1321	1333	1321	485	580	855	3900
24x20	471	1549	1568	1549	1060	550	900	5850	1549	1568	1549	1060	550	900	5160	1549	1568	1549	604	629	1040	5400
30x24	570	1880	1902	1880	1250	630	1100	9400	1880	1902	1880	1250	630	1100	8950	1880	1902	1880	665	640	1230	9000
36x30	712	2286	2315	2286	1460	740	1350	16400	2286	2315	2286	1460	740	1350	15100	2286	2315	2286	795	777	1460	15200

Design, weights and dimensions not established by International Standards are subject to change without notice.

Dimensions in mm

OVERALL DIMENSIONS & WEIGHT



Trunnion mounted ball valves

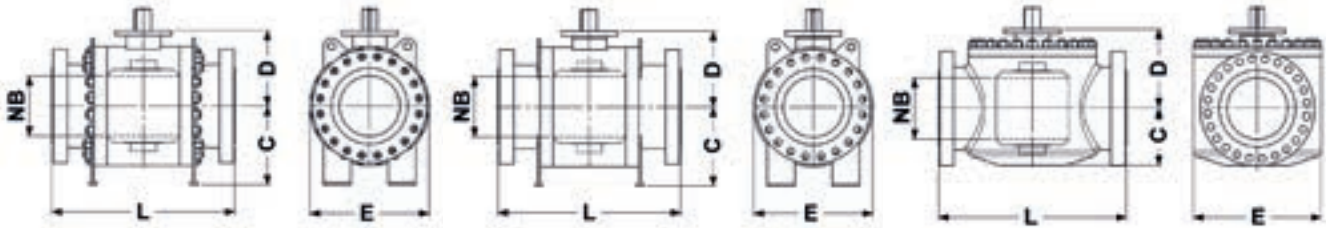

CLASS 1500 FULL BORE

SIZE		SPLIT BODY								FULLY WELDED BODY								TOP ENTRY							
inches	NB	L RF	L RTJ	L BW	C	D	E	WEIGHT (kg)	L RF	L RTJ	L BW	C	D	E	WEIGHT (kg)	L RF	L RTJ	L BW	C	D	E	WEIGHT (kg)			
2	49	368	371	368	108	125	216	60	368	371	368	108	125	216	55	368	371	368	87	212	216	56			
3	74	470	473	470	135	160	267	103	470	473	470	135	160	267	95	470	473	470	118	236	267	153			
4	100	546	549	546	160	215	311	185	546	549	546	160	215	311	170	546	549	546	150	294	311	278			
6	144	705	711	705	340	325	394	489	705	711	705	340	325	394	450	705	711	705	236	303	394	600			
8	192	832	841	832	380	365	483	850	832	841	832	380	365	483	750	832	841	832	285	354	483	1100			
10	239	991	1000	991	450	430	584	1540	991	1000	991	450	430	584	1450	991	1000	991	333	398	585	1440			
12	287	1130	1146	1130	540	535	673	2320	1130	1146	1130	540	535	673	2200	1130	1146	1130	427	520	709	2000			
14	315	1257	1276	1257	560	550	750	2650	1257	1276	1257	560	550	750	2500	1257	1276	1257	456	550	765	2600			
16	360	1384	1407	1384	590	580	830	3890	1384	1407	1384	590	580	830	3750	1384	1407	1384	487	565	848	3900			
18	406	1537	1559	1537	630	600	950	6040	1537	1559	1537	630	600	950	5250	1537	1559	1537	527	592	980	5000			
20	454	1664	1686	1664	680	640	1005	8350	1664	1686	1664	680	640	1005	8000	1664	1686	1664	630	650	1015	6700			
24	546	1943	1972	1943	750	700	1280	13480	1943	1972	1943	750	700	1280	12000	1943	1972	1943	640	660	1293	11650			

CLASS 1500 REDUCED BORE

SIZE		SPLIT BODY								FULLY WELDED BODY								TOP ENTRY							
inches	NB	L RF	L RTJ	L BW	C	D	E	WEIGHT (kg)	L RF	L RTJ	L BW	C	D	E	WEIGHT (kg)	L RF	L RTJ	L BW	C	D	E	WEIGHT (kg)			
2x1,5	38	368	371	368	95	115	216	55	368	371	368	95	115	216	50	368	371	368	80	211	216	50			
3x2	49	470	473	470	105	125	267	98	470	473	470	105	125	267	90	470	473	470	80	211	267	100			
4x3	74	546	549	546	130	160	311	142	546	549	546	130	160	311	130	546	549	546	118	236	311	200			
6x4	100	705	711	705	160	180	394	310	705	711	705	160	180	394	250	705	711	705	153	287	394	380			
8x6	144	832	841	832	350	325	483	590	832	841	832	350	325	483	510	832	841	832	236	303	483	700			
10x8	192	991	1000	991	400	365	584	1150	991	1000	991	400	365	584	1050	991	1000	991	285	349	585	1280			
12x10	239	1130	1146	1130	460	430	673	1820	1130	1146	1130	460	430	673	1700	1130	1146	1130	330	404	675	1540			
14x10	239	1257	1276	1257	460	430	750	2150	1257	1276	1257	460	430	750	2000	1257	1276	1257	330	404	750	2100			
14x12	287	1257	1276	1257	550	535	750	2480	1257	1276	1257	550	535	750	2300	1257	1276	1257	427	530	750	2700			
16x12	287	1384	1407	1384	550	535	830	2750	1384	1407	1384	550	535	830	2600	1384	1407	1384	427	530	825	3100			
16x14	315	1384	1407	1384	580	550	830	3300	1384	1407	1384	580	550	830	3000	1384	1407	1384	455	540	825	3200			
18x16	360	1537	1559	1537	600	580	920	4890	1537	1559	1537	600	580	920	4600	1537	1559	1537	493	557	916	4200			
20x16	360	1664	1686	1664	600	580	990	5250	1664	1686	1664	600	580	990	4500	1664	1686	1664	493	557	985	4500			
20x18	406	1664	1686	1664	650	600	990	7100	1664	1686	1664	650	600	990	6450	1664	1686	1664	527	593	985	6000			
24x20	454	1943	1972	1943	700	640	1180	10200	1943	1972	1943	700	640	1180	9100	1943	1972	1943	620	657	1170	9000			

Design, weights and dimensions not established by International Standards are subject to change without notice.

Dimensions in mm



Trunnion mounted ball valves

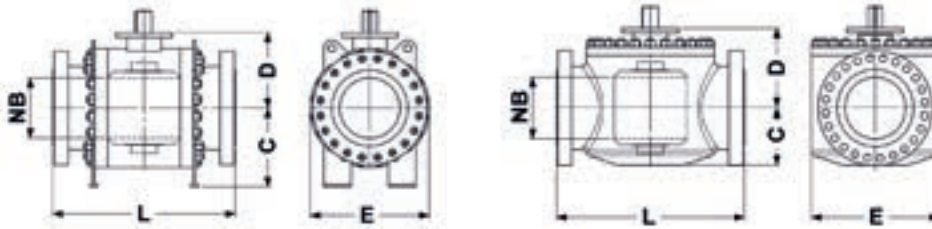

CLASS 2500 FULL BORE

SIZE		SPLIT BODY								TOP ENTRY					
inches	NB	L RF	L RTJ	L BW	C	D	E	WEIGHT (kg)	L RF	L RTJ	L BW	C	D	E	WEIGHT (kg)
2	42	451	454	451	125	150	235	96	451	454	451	98	212	235	120
3	62	578	584	578	155	185	280	205	578	584	578	122	243	319	245
4	87	673	683	673	195	230	340	345	673	683	673	164	299	364	470
6	131	914	927	914	360	350	485	795	914	927	914	243	355	482	940
8	179	1022	1038	1022	400	400	620	1410	1022	1038	1022	292	424	550	1400
10	223	1270	1292	1270	480	450	750	2120	1270	1292	1270	352	503	675	2600
12	265	1422	1445	1422	550	550	880	3250	1422	1445	1422	436	588	765	4200

CLASS 2500 REDUCED BORE

SIZE		SPLIT BODY								TOP ENTRY					
inches	NB	L RF	L RTJ	L BW	C	D	E	WEIGHT (kg)	L RF	L RTJ	L BW	C	D	E	WEIGHT (kg)
2x1,5	38	451	454	451	125	140	220	90	451	454	451	98	212	240	80
3x2	42	578	584	578	155	150	235	182	578	584	578	98	212	305	160
4x3	62	673	683	673	195	185	280	305	673	683	673	122	243	356	300
6x4	87	914	927	914	360	230	340	548	914	927	914	164	299	483	670
8x6	131	1022	1038	1022	400	350	485	1120	1022	1038	1022	243	355	550	1150
10x8	179	1270	1292	1270	480	400	680	1830	1270	1292	1270	292	424	675	2100
12x10	223	1422	1445	1422	550	450	770	2710	1422	1445	1422	352	503	760	3300

Dimensions in mm

Wellhead API 6A ball valves

CLASS API 2000

SIZE		SPLIT BODY				
inches	NB	L RTJ	C	D	E	WEIGHT (kg)
2 1/16	52,4	295	120	160	215	38
2 9/16	65,1	333	130	180	225	56
3 1/8	81,0	359	155	200	255	69
4 1/16	103,2	435	200	250	260	97
5 1/8	130,2	511	240	300	295	233
7 1/16	179,4	562	270	350	330	342

CLASS API 3000

SIZE		SPLIT BODY				
inches	NB	L RTJ	C	D	E	WEIGHT (kg)
2 1/16	52,4	371	120	170	210	67
2 9/16	65,1	384	130	190	230	89
3 1/8	81,0	422	155	220	240	117
4 1/16	103,2	460	200	270	270	195
5 1/8	130,2	562	240	320	315	472
7 1/16	179,4	613	270	370	375	692

CLASS API 5000

SIZE		SPLIT BODY				
inches	NB	L RTJ	C	D	E	WEIGHT (kg)
2 1/16	52,4	371	130	180	210	67
2 9/16	65,1	422	150	200	230	89
3 1/8	81,0	473	200	230	260	117
4 1/16	103,2	549	220	290	340	195
5 1/8	130,2	676	270	370	390	472
7 1/16	179,4	711	350	410	435	692

CLASS API 10000

SIZE		SPLIT BODY				
inches	NB	L RTJ	C	D	E	WEIGHT (kg)
1 13/16	46,0	464	170	200	230	118
2 1/16	52,4	521	200	240	270	176
2 9/16	65,1	565	220	275	325	244
3 1/16	77,8	619	240	290	325	362
4 1/16	103,2	670	280	310	415	648
5 1/8	130,2	737	375	450	570	847
7 1/16	179,4	889	435	500	695	1620

Design, weights and dimensions not established by International Standards are subject to change without notice.

Dimensions in mm

Floating ball valves

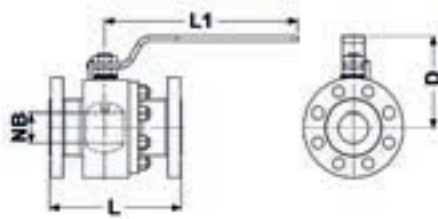

CLASS 150 FULL BORE

SIZE		SPLIT BODY					WEIGHT (kg)
inches	NB	L RF	L BW	L1	D		
1/2	14	108	140	185	90	3	
3/4	19	117	152	185	90	4	
1	25	127	165	185	95	6	
1 1/2	38	165	191	365	125	11	
2	51	178	216	365	130	17	
3	76	203	283	455	155	28	
4	102	229	305	455	170	49	
6	152	394	457	800	300	65	

CLASS 150 REDUCED BORE

SIZE		SPLIT BODY					WEIGHT (kg)
inches	NB	L RF	L BW	L1	D		
3/4 x 1/2	14	117	152	185	90	4	
1 x 3/4	19	127	165	185	90	5	
1 1/2 x 1	25	165	190	185	95	10	
2 x 1 1/2	38	178	216	365	125	15	
3 x 2	51	203	283	365	130	25	
4 x 3	76	229	305	455	155	42	
6 x 4	102	384	457	455	170	60	

CLASS 300 FULL BORE

SIZE		SPLIT BODY					WEIGHT (kg)
inches	NB	L RF	L BW	L1	D		
1/2	14	140	140	185	90	4	
3/4	19	152	152	185	90	6	
1	25	165	165	185	95	8	
1 1/2	38	191	191	365	125	16	
2	51	216	216	365	130	21	
3	76	283	283	455	155	40	
4	102	305	305	455	170	65	
6	152	403	403	800	300	130	

CLASS 300 REDUCED BORE

SIZE		SPLIT BODY					WEIGHT (kg)
inches	NB	L RF	L BW	L1	D		
3/4 x 1/2	14	152	152	185	90	5	
1 x 3/4	19	165	165	185	90	7	
1 1/2 x 1	25	190	190	185	95	14	
2 x 1 1/2	38	216	216	365	125	18	
3 x 2	51	283	283	365	130	35	
4 x 3	76	305	305	455	155	60	
6 x 4	102	403	457	455	170	120	

CLASS 600 FULL BORE

SIZE		SPLIT BODY					WEIGHT (kg)
inches	NB	L RF	L RTJ	L BW	L1	D	
1/2	14	165	165	165	185	90	7
3/4	19	191	191	191	185	90	9
1	25	216	216	216	185	95	12
1 1/2	28	241	241	241	365	125	19
2	51	292	295	295	365	130	26
3	76	356	359	356	600	155	47

CLASS 600 REDUCED BORE

SIZE		SPLIT BODY						WEIGHT (kg)
inches	NB	L RF	L RTJ	L BW	L1	D		
3/4 x 1/2	14	191	191	191	185	90	9	
1 x 3/4	19	216	216	216	185	90	13	
1 1/2 x 1	25	241	241	241	185	95	18	
2 x 1 1/2	38	292	295	292	365	125	24	
3 x 2	51	356	359	356	365	130	38	
4 x 3	76	432	435	432	600	155	66	

Design, weights and dimensions not established by International Standards are subject to change without notice.

Dimensions in mm



Floating ball valves

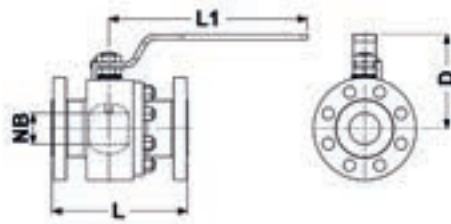

CLASS 900 FULL BORE

SIZE		SPLIT BODY					
inches	NB	L RF	L RTJ	L BW	L1	D	WEIGHT (kg)
1/2	14	216	216	216	276	95	12
3/4	19	229	229	229	276	95	18
1	25	254	254	254	276	105	24
1 1/2	38	305	305	305	365	130	32
2	51	368	371	368	400	155	43

CLASS 900 REDUCED BORE

SIZE		SPLIT BODY					
inches	NB	L RF	L RTJ	L BW	L1	D	WEIGHT (kg)
3/4 x 1/2	14	229	229	229	276	95	14
1 x 3/4	19	254	254	254	276	95	20
1 1/2 x 1	25	305	305	305	276	105	27
2 x 1 1/2	38	368	371	368	365	130	35
3 x 2	51	381	384	381	400	155	49

CLASS 1500 FULL BORE

SIZE		SPLIT BODY					
inches	NB	L RF	L RTJ	L BW	L1	D	WEIGHT (kg)
1/2	14	216	216	216	276	95	16
3/4	19	229	229	229	276	95	18
1	25	254	254	254	276	105	26
1 1/2	51	305	305	305	400	130	39

CLASS 1500 REDUCED BORE

SIZE		SPLIT BODY					
inches	NB	L RF	L RTJ	L BW	L1	D	WEIGHT (kg)
3/4 x 1/2	14	229	229	229	276	95	18
1 x 3/4	19	254	254	254	276	95	22
1 1/2 x 1	25	305	305	305	276	105	30
2 x 1 1/2	38	368	371	368	400	130	44

CLASS 2500 FULL BORE

SIZE		SPLIT BODY					
inches	NB	L RF	L RTJ	L BW	L1	D	WEIGHT (kg)
1/2	14	264	264	264	276	95	18
3/4	19	273	273	273	276	95	25
1	25	308	308	308	276	105	33

CLASS 2500 REDUCED BORE

SIZE		SPLIT BODY					
inches	NB	L RF	L RTJ	L BW	L1	D	WEIGHT (kg)
3/4 x 1/2	14	273	273	273	276	95	20
1 x 3/4	19	308	308	308	276	95	28
1 1/2 x 1	25	384	384	384	276	105	36

Design, weights and dimensions not established by International Standards are subject to change without notice.

Dimensions in mm



Stem Extensions

Stem extensions can be provided to permit underground or buried installation. Extension length (dimension from the ball valve centerline to the hand wheel centerline) shall be specified.

Vent (standard)

Ball valves NPS 6" and larger are provided with vent located in the upper part of ball valve body.

Lifting lugs

Standard for NPS 6" and larger.

Supporting feet

Standard for NPS 6" and larger.

Drain (standard)

All sizes of trunnion mounted ball valves are provided with drain plug located in the lower part of ball valve body.

Emergency Sealant Injection

An emergency sealant injection system is available upon request, which can restore the sealing integrity if damage is caused to sealing surface or gaskets.

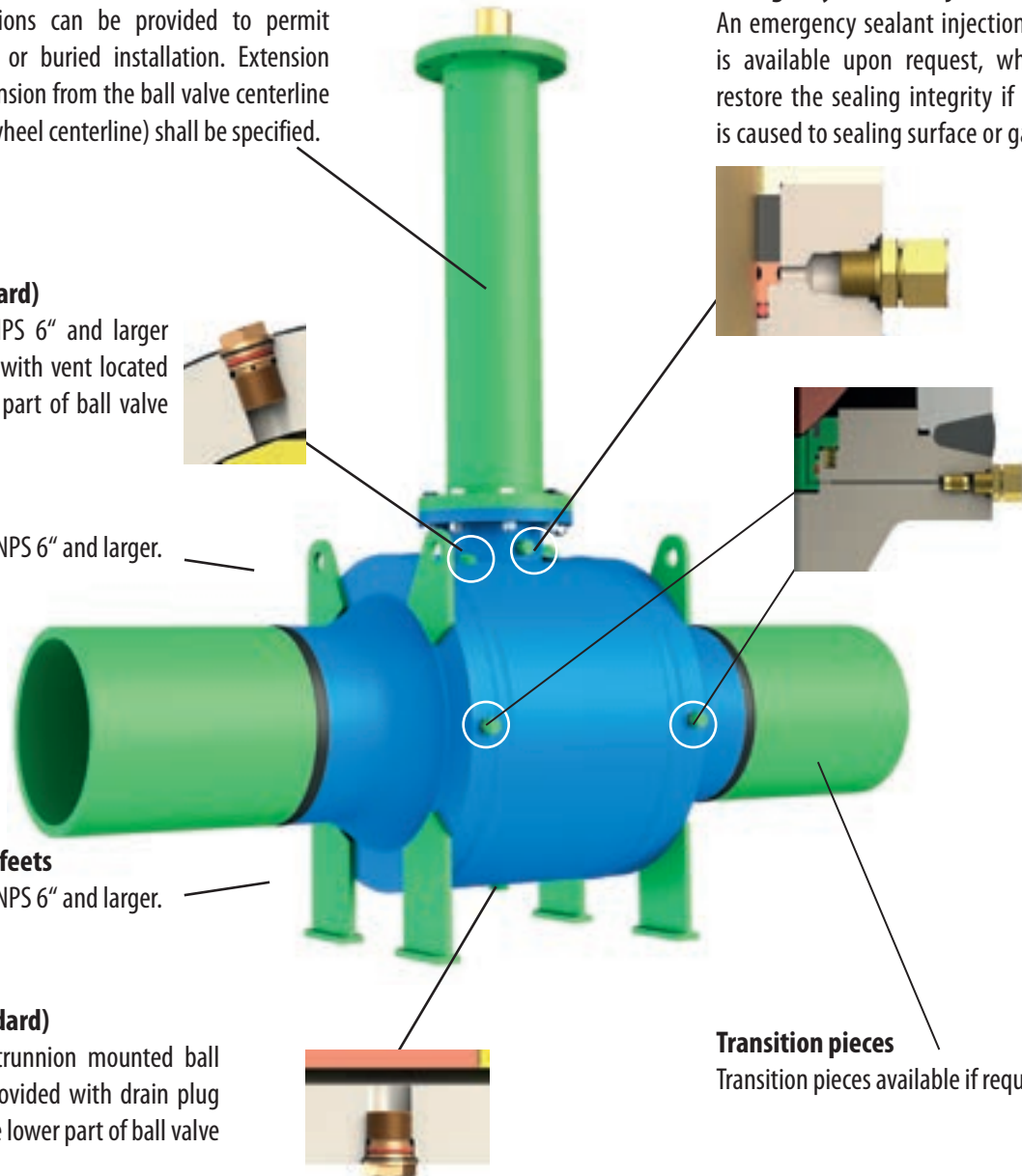

Transition pieces

Transition pieces available if required.

Actuators

Ball valves can be equipped with any actuator type or gearbox. Locking device can be provided as well.

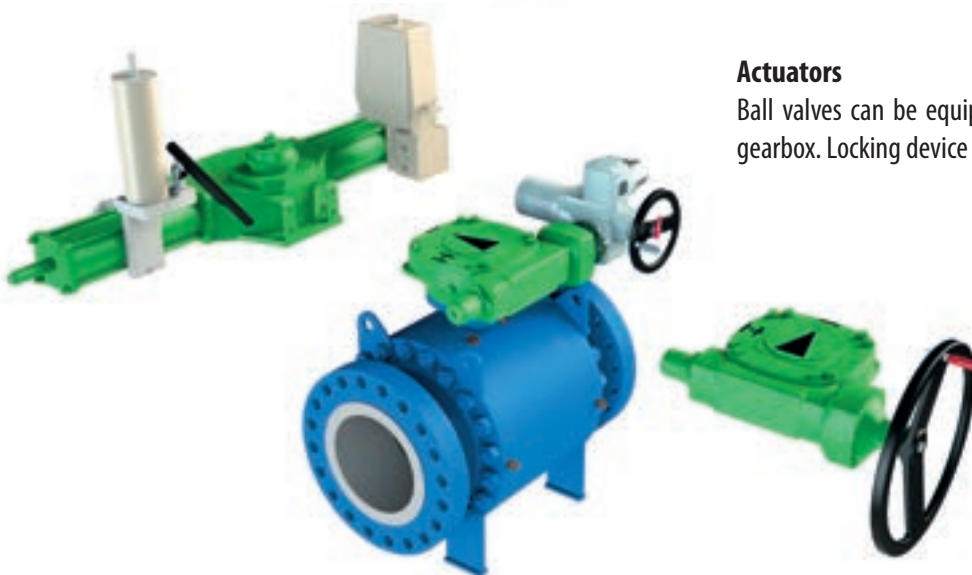



FLOW DATA

FLOW COEFFICIENTS Cv						
Size (inches)	Class					
	150	300	600	900	1500	2500
1/2	16	14	12	11	11	10
3/4	44	38	34	31	30	29
1	90	78	69	65	63	47
1 1/2	227	211	187	167	163	90
2 x 1 1/2	145	145	140	120	120	100
2	420	420	400	330	330	250
2 1/2	690	690	610	520	510	320
3 x 2	200	200	200	190	180	200
3	1200	1050	1000	910	820	500
4 x 3	600	600	600	590	550	560
4	2200	2100	1850	1800	1700	1100
6 x 4	800	800	790	790	780	745
6	5150	5100	4600	4380	3800	2500
8 x 6	2150	2150	2150	2150	2150	2150
8	9500	9400	9000	8500	7400	5300
10 x 8	4300	4300	4300	4450	4450	4100
10	15000	15000	14700	14500	11500	8300
12 x 10	7550	7550	7550	8000	9000	7550
14 x 10	6000	6000	6000	6100	6100	
12	23000	23000	22500	21100	18000	13000
14 x 12	14000	14000	14000	12800	13000	
16 x 12	9100	9100	9100	8900	8900	
14	28000	28000	28000	25000	21000	
16 x 14	15000	15000	15000	14200	14100	
16	37200	37200	37200	34500	27500	
18 x 16	21000	21000	21000	19200	19000	
20 x 16	15300	15300	15300	13800	12000	
18	49000	49000	49000	45000	37000	
20 x 18	28400	28400	28400	25000	25000	
20	59000	59000	59000	55200	47800	
24 x 20	28200	28200	28000	25100	20600	
22	68200	68200	68200	62000	54000	
24	92000	92000	92000	83800	70000	
30 x 24	36000	36000	36000	32900		
26	110000	110000	110000	98500		
28	121000	121000	121000	113000		
30	145000	144000	144000	130000		
36 x 30	64000	64000	64000	61500		
32	170000	170000	170000	151000		
36 x 32	87000	87000	87000	69500		
36	210000	210000	210000	198200		
40	267500	267500	267500			
42 x 36	96700	96700	96700			
42	280000	280000	280000			
48	384000	384000	384000			
56	521000	521000	521000			

STOCK OF BALL VALVES



TIV VALVES has a large inventory of ball valves.

The range of stock ball valves is from 2"/class 150 up to 12"/class 1500 and 16"/class 600.

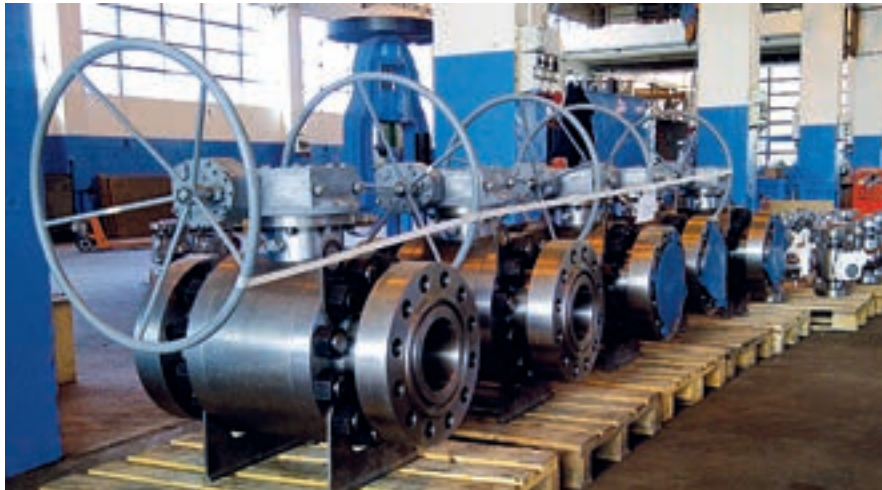

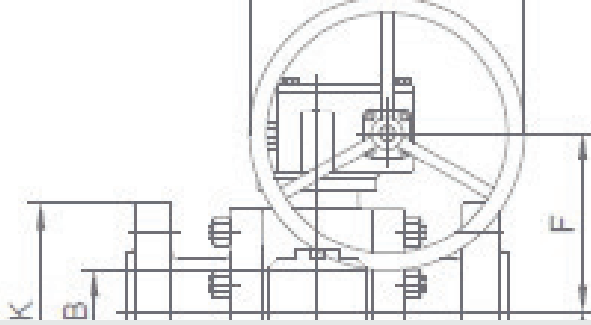

NOTE: This catalogue is for general information only. TIV VALVES will not be responsible for any mistakes contained in it or for any damage either accidental or due to the use of this catalogue. The information herein contained is reserved property of TIV VALVES srl and is subject to be modified without notice.

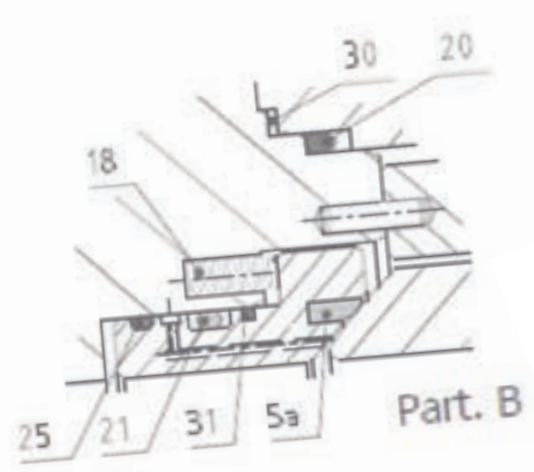
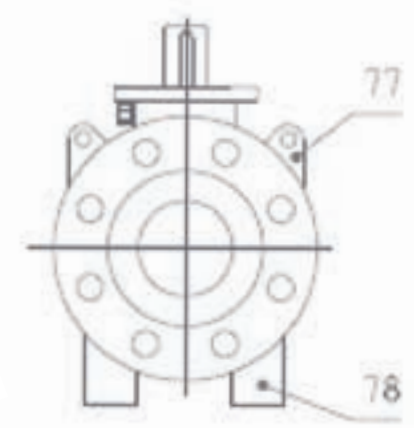
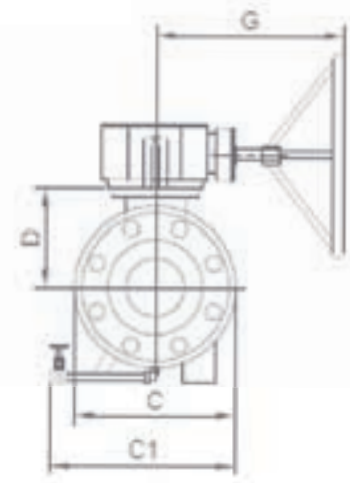
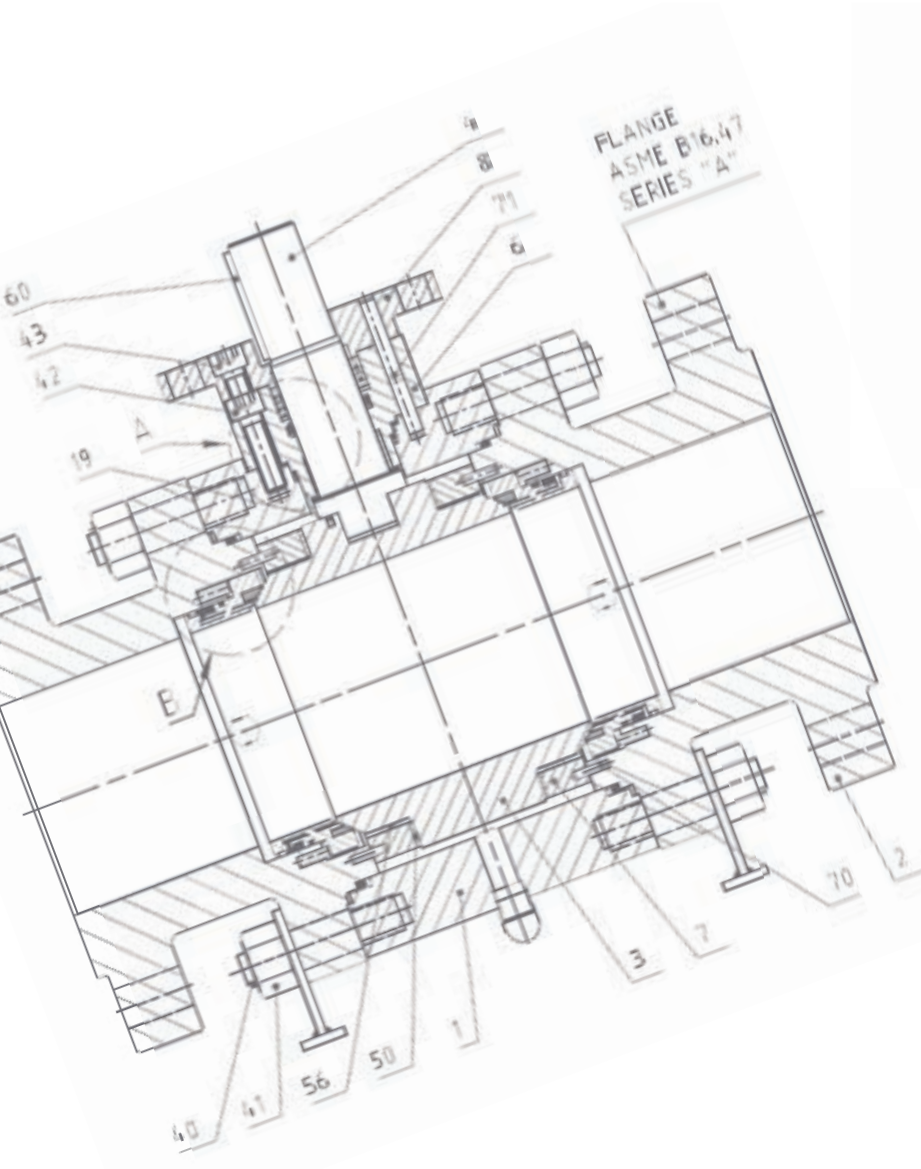

TIV VALVES srl

Headquarters:

Via Provinciale Saronnese, 58

20027 Rescaldina (MI) Italy

Phone: +39 0331 579931

Fax: +39 0331 577806

Production:

Via Caboto, 10/12 - 20025, Legnano (MI) Italy

E-mail: info@tiv-valves.com