

Filter Housings



Standard Housing



The Model 11N, 21N and 23N filter housings are tested and certified by NSF International under ANSI/NSF Standard 42 for material and structural integrity requirements.



Standard housings offer the following:

- White talc reinforced polypropylene head with blue talc reinforced or clear styrene acrylonitrile (SAN) bowl.
- Standard 3/4" NPT connections.
- Securely retained Buna "N" O-Ring to ensure effective static sealing.
- Positive head to bowl "stop" to prevent bowl overtightening.
- Available from stock with or without pressure relief vent button.
- Custom colors available by special order.
- Mounting bosses in head for available bracket.
- Accepts industry standard cartridge size: 2 3/4" O.D. x 1" I.D. x 9 3/4" (full length), 4 7/8" (half size) and 20" (double length).
- Full testing to industry standards of the Water Quality Association for burst pressure, water tightness and fatigue resistance.

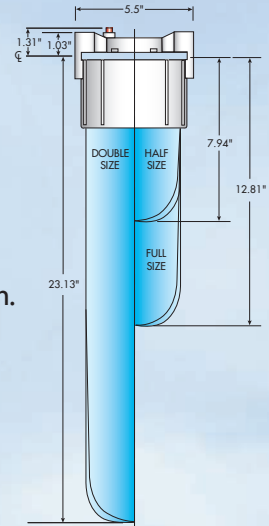

Specifications

Model Number	Maximum Operating Temp. °F (°C)	Maximum Operating Press. PSI* (BAR)	Shipping Weight Lb (kg)**	Size	Housing Material and Style
11N	125 (52)	150 (10)	3.3 (1.50)	Full	White Polypro Head, Blue Polypro Bowl
12N	125 (52)	150 (10)	2.6 (1.18)	Half	White Polypro Head, Blue Polypro Bowl
13N	125 (52)	150 (10)	4.5 (2.04)	Double	White Polypro Head, Blue Polypro Bowl
21N	125 (52)	150 (10)	3.3 (1.50)	Full	White Polypro Head, Clear Styrene Bowl
22N	125 (52)	150 (10)	2.6 (1.18)	Half	White Polypro Head, Clear Styrene Bowl
23N	125 (52)	150 (10)	4.5 (2.04)	Double	White Polypro Head, Clear Styrene Bowl

*At 70°F (21°C) **Multiply by 12 to obtain weight per case.

Housings can be ordered with a differential pressure gauge by adding the letter "G" after the model #. Housings can be ordered without a relief button by adding the letter "X" after the model #.

High Temperature Nylon Housings



These housings are suitable for high temperature service. Features include:

- Distinctive red color.
- High strength glass reinforced nylon head and bowl.
- Standard 3/4" NPT connections.
- Securely retained Buna "N" O-Ring to ensure effective static sealing.
- Not available with pressure relief vent button.
- Full testing to industry standards of the Water Quality Association for burst pressure, water tightness and fatigue resistance.

Specifications

Model Number	Maximum Operating Temp. °F (°C)	Maximum Operating Press. PSI (BAR)	Shipping Weight Lb (kg)**	Size	Housing Material and Style
31	165 (74)	100 (6.9)	3.2 (1.45)	Full	Red Reinforced Nylon Head and Bowl
32	165 (74)	100 (6.9)	2.3 (1.04)	Half	Red Reinforced Nylon Head and Bowl

**Multiply by 12 to obtain weight per case.

GIANT® Housings



Giant Housings

The Model BG10, BG20, CG10 and CG20 filter housings are tested and certified by NSF International under ANSI/NSF Standard 42 for material and structural integrity requirements.



GIANT® housings offer maximum filtration capacity in a compact unit. These housings feature:

- Talc polypropylene, clear styrene, natural polypropylene and glass reinforced nylon construction.
- Unique “Stacked Threads” - both 1" and 1-1/2" NPT connections in the same head.
- Nylon housings for high temperature and high pressure service.
- Bag housings in all materials. (Bags are also available). Request Bulletin GH-B.
- Optional differential pressure gauge available.

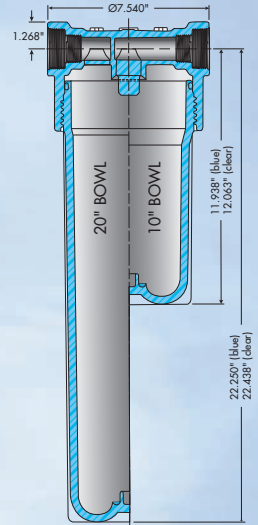

For Cold Water Applications

Model Number	Maximum Operating Temp. °F (°C)	Maximum Operating Press. PSI* (BAR)	Shipping Weight Lb (kg)**	Size	Housing Material and Style
BG10	125 (52)	100 (6.9)	5.10 (2.31)	Full	White Polypro Head, Blue Polypro Bowl
BG20	125 (52)	100 (6.9)	7.13 (3.23)	Double	White Polypro Head, Blue Polypro Bowl
CG10	125 (52)	100 (6.9)	4.13 (1.87)	Full	White Polypro Head, Clear Styrene Bowl
CG20	125 (52)	100 (6.9)	7.12 (3.23)	Double	White Polypro Head, Clear Styrene Bowl
NPGX10	125 (52)	100 (6.9)	3.13 (1.42)	Full	Pure Polypropylene w/o Pressure Relief Button
NPGXD10	125 (52)	100 (6.9)	3.13 (1.42)	Full	Pure Polypropylene w/ Tapped Drain
NPGX20	125 (52)	100 (6.9)	5.15 (2.34)	Double	Pure Polypropylene w/o Pressure Relief Button
NPGXD20	125 (52)	100 (6.9)	5.15 (2.34)	Double	Pure Polypropylene w/ Tapped Drain

*At 70°F (21°C) **Multiply by 4 to obtain weight per case. †1/4" NPT top and bottom drain.

For High Temperature Applications

Model Number	Maximum Operating Temp. °F (°C)	Maximum Operating Press. PSI (BAR)	Shipping Weight Lb (kg)**	Size	Housing Material and Style
HTGX10	180 (82)	100 (6.9)	5.88 (2.67)	Full	Reinforced Nylon Head and Bowl
HTGX20	180 (82)	100 (6.9)	8.25 (3.74)	Double	Reinforced Nylon Head and Bowl

All inlet/outlet ports are 1" and 1 1/2".



GIANT® 222 housings - with 222 fitting in head to accept ONLY 222 style GIANT® cartridges - are available with white talc polypropylene heads and white talc polypropylene or clear styrene bowls. Request Bulletin GH-222

Stainless Steel Housings

Single Tube



Keystone's versatile and rugged stainless steel housings are useful for a broad range of applications. Their features include:

- Rugged 304 SS construction allows for use in applications where stainless steel is preferred, including food and beverage.
- High maximum temperature operation make these housings the perfect choice for high temperature applications, including hot water and hot process liquids.
- Available in both standard and Giant sizes. Model Numbers starting in "SS" are standard, "SG" are Giant.



Specifications

Model Number	Maximum Operating Press. PSI* (BAR)	Dimensions† Height	Diameter	Number of Cartridges	Use Cartridge Size	Pipe Size† (NPT)
SS10	250 (17.2)	13.4	4.17	1	2.5" OD x 9.75"-10" L	.75
SS20	250 (17.2)	23.4	4.17	1	2.5" OD x 20" L	.75
SG10	250 (17.2)	14.8	5.83	1	4.5" OD x 9.75"-10" L	1
SG20	250 (17.2)	24.8	5.83	1	4.5" OD x 20" L	1.5

*To 275°F (136°C).

†Dimensions are in inches.

Multi Tube



These housings feature:

- High quality 304 stainless steel construction with epoxy coating on outside of housing.
- Belly-band clamp closures included for easy cartridge change.
- 1/2" drains are provided on clean and dirty sides.
- Larger multiple cartridge housings with connection sizes up to 3" flange are also available.
- Additional exterior finishes are available; optional electro polished stainless steel is shown at left.

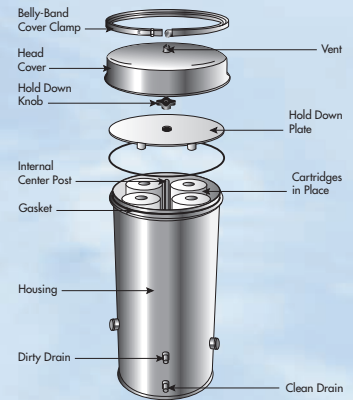

Specifications

Model Number	Rated Capacity GPM (LPM)	Maximum Operating Press. PSI* (BAR)	Dimensions† Height	Diameter	Number of Cartridges	Pipe Size† (NPT)	Shipping Weight Lb (kg)
414	28 (106)	150 (10)	19.25	10.0	(4) 10"	2.0	20 (9.07)
434	56 (212)	150 (10)	29.0	10.0	(4) 20"	2.0	30 (13.61)
444	84 (318)	150 (10)	38.75	10.0	(4) 30"	2.0	40 (18.14)
4312	168 (636)	150 (10)	29.0	17.0	(12) 20"	3.0	125 (56.70)
4412	252 (954)	150 (10)	38.75	17.0	(12) 30"	3.0	140 (63.50)
4512	336 (1,272)	150 (10)	49.0	17.0	(12) 40"	3.0	160 (72.57)

*To 300°F(150°C). Above rated flow capacities based on sediment removal with a 10 micron pleated filter cartridge. Standard housing gasket is Buna "N"; other materials on request. †Dimensions are in inches.

Pure Polypropylene Housings



Keystone's pure polypropylene filter housings are ideal for use in all industries where filtered liquids must remain totally free of contamination. These housings are especially essential in the semi-conductor, pharmaceutical and chemical processing industries. They are constructed entirely of virgin polypropylene without color, adders, fillers, reinforcements or lubricants.

In critical applications, these all natural housings insure pure, cost effective filtration of a variety of solvents, acids, alcohols and chemicals without leaching or bacterial build up. Keystone 100% polypropylene housings provide an inexpensive alternative to teflon or fluoropolymer housings.

Features include:

- 100% polypropylene construction.
- Smooth contact surfaces to prevent bacteria and dirt buildup.
- Utilizes a non-lubricated silicone O-ring standard.
- Standard $\frac{3}{4}$ " NPT connections.

Applications include:

- Deionized water.
- Laboratory instrumentation and equipment.
- Pharmaceutical/cosmetic solvents.
- Electronic solutions and chemicals.
- Post filter for reverse osmosis or ultrafiltration.

Specifications

Model Number	Maximum Operating Temp. °F (°C)	Maximum Operating Press. PSI* (BAR)	Shipping Weight Lb (kg)**	Size	Housing Style
51NX	125 (52)	150 (10)	2.4 (1.09)	Full	w/o pressure relief button
51NXD†	125 (52)	150 (10)	2.4 (1.09)	Full	w/ tapped drain
51NX-222	125 (52)	150 (10)	2.4 (1.09)	Full	w/ 222 O-ring configuration
51NXD-222†	125 (52)	150 (10)	2.4 (1.09)	Full	w/ 222 O-ring configuration & drain
52NX	125 (52)	150 (10)	1.2 (0.54)	Half	w/o pressure relief button
53NX	125 (52)	150 (10)	3.4 (1.54)	Double	w/o pressure relief button
53NXD†	125 (52)	150 (10)	3.4 (1.54)	Double	w/ tapped drain
53NX-222	125 (52)	150 (10)	3.4 (1.54)	Double	w/ 222 O-ring configuration
53NXD-222†	125 (52)	150 (10)	3.4 (1.54)	Double	w/ 222 O-ring configuration & drain

*At 70°F (21°C) **Multiply by 12 to obtain weight per case. † $\frac{1}{4}$ " NPT bottom drain. Housings can be ordered with a differential pressure gauge by adding the letter "G" after the model #.

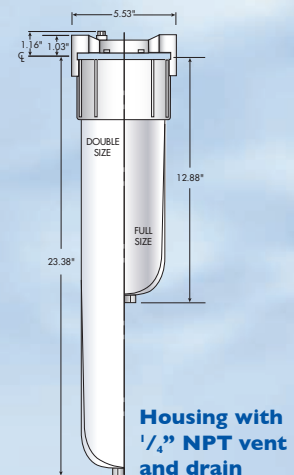
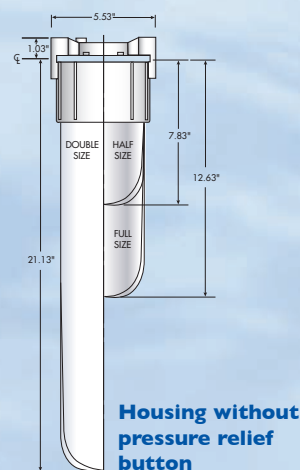
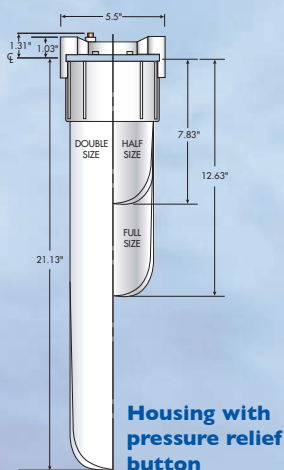



Cartridges

Keystone Filter manufactures a wide variety of replacement cartridges that are interchangeable in virtually every style of nominal 2³/₄" diameter cartridge filter housing. Cartridges are available in a variety of materials including cellulose, activated carbon, microfiberglass and polypropylene. Keystone's pleated cartridges feature all polypropylene construction in nominal ratings from 0.1 to 30 micron, with end caps that will fit all standard and sanitary style housings. Pleated cartridges are stocked in single and continuous multiple length configurations. Activated carbon cartridges are available in convolutely wound or granular filled constructions.

For additional information, request Bulletin FPT and Bulletin PT.

- LONGER LIFE
- HIGHER FLOW RATE
- LESS PRESSURE LOSS
- UNIQUE, UNIVERSAL DESIGN



Custom Capabilities

Whether you have firm specifications or only a general concept, we can work with you to design and manufacture your special filter. We can function as a custom pleater or as a fabricator of complete cartridges. Flexibility in our manufacturing operation provides shorter lead times and lower tooling costs.

Maintaining regular contact with leading media suppliers assures that we keep current with latest developments in filter media technology.

More than two decades of experience in the design and fabrication of numerous configurations can be put to work to find the optimum solution to your filtration problem.

For additional information, request Bulletin CB 200.

About CECO

CECO Environmental, through its Fluid Handling/Filtration Technologies Segment consisting of CECO Filters, Keystone Filter, Mefiag Filtration, Met-Pro Global Pump Solutions and Strobic Air, offers a broad range of products and solutions including high quality centrifugal pumps for corrosive, abrasive and high temperature liquids, filter products for air, liquid, and product recovery, and technologically advanced air movement and fume exhaust systems. CECO is also a global leader in environmental and energy technologies.



A CECO Environmental Company

700 Emlen Way • Telford, PA 18969

Toll Free: (800) 822-1963 • **Fax:** (215) 997-1839

filters@keystonefilter.com • www.keystonefilter.com

©COPYRIGHT 2015 CECO ENVIRONMENTAL CORPORATION, KEYSTONE FILTER



05-5500.h 715