

dbx[®] *PROFESSIONAL PRODUCTS*

DriveRack[®] PX

Quick Start Guide

An illustrated guide to setting up your DriveRack[®] PX



This Quick Start Guide will walk you through your first and subsequent setups, step by step. To keep things simple, we'll use a common powered speaker setup: two mains and two subwoofers, shown below. (For diagrams of additional setups, refer to your User's Manual.) If you're not using subwoofers, just disregard instructions that refer to subwoofers. For this example, we'll use JBL PRX515's and JBL PRX518's, but you can use almost any powered speakers and powered subwoofers with the DriveRack PX.

If you're using the DriveRack PX for the first time, begin on page 3.

If you've already set up and saved a preset for your powered speakers, and just want to optimize your powered speakers for a new room or venue, begin on page 14.

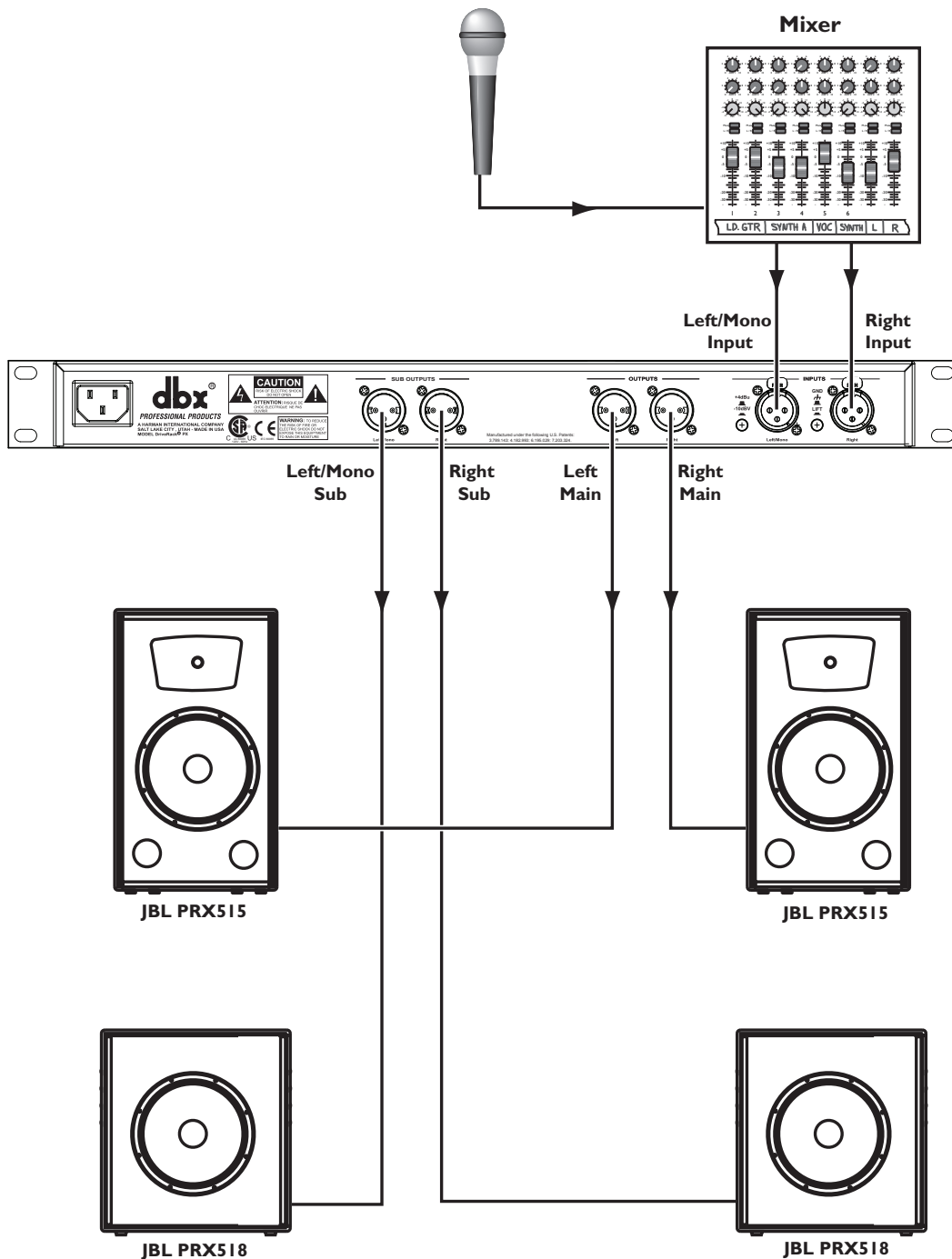

First-time Setup - Creating a New Preset

1. Remove the DriveRack PX from its box.
 Rack mount the DriveRack PX and connect the power cord.

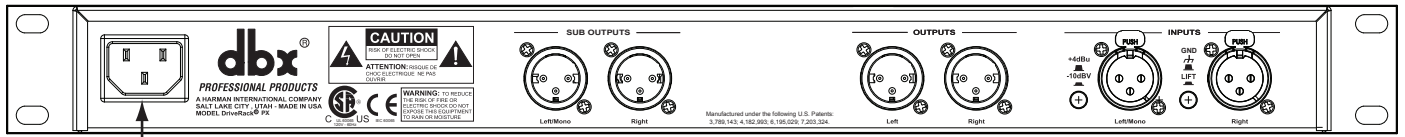

Attach power cord here.

2. Connect the mixer left and right outputs to the DriveRack PX Left/Mono and Right Inputs.

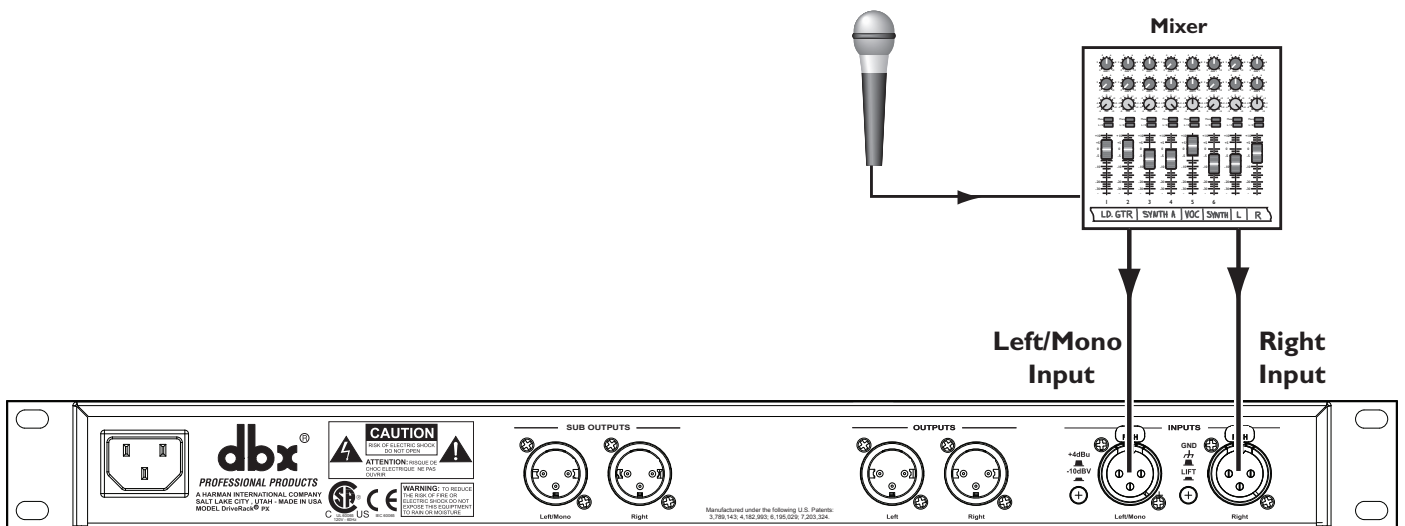

3. Make sure your powered speakers and subwoofers are turned off.

Connect the Left and Right "OUTPUTS" to the left and right main powered speakers.

Connect the Left/Mono and Right "SUB OUTPUTS" to the left and right subwoofers.

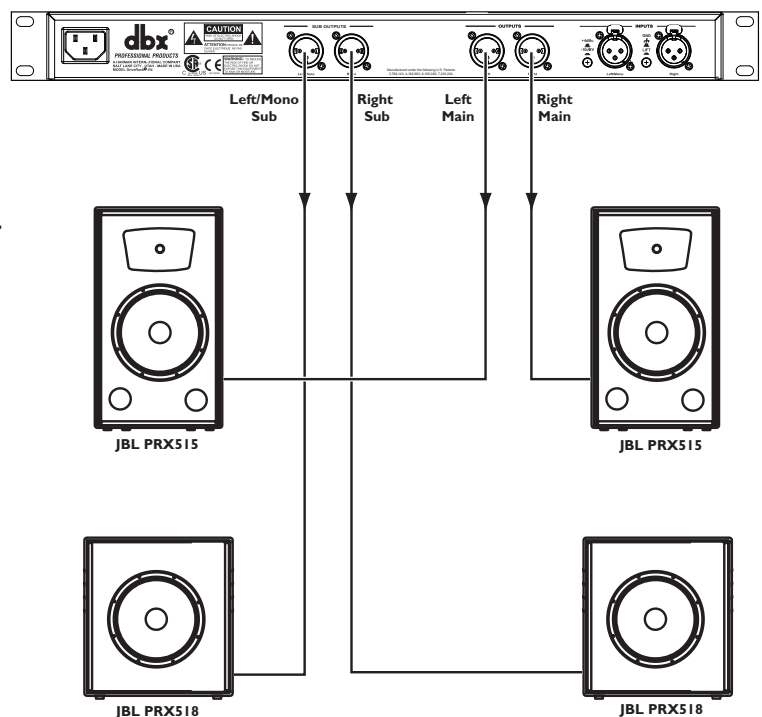

- Turn the mixer master faders down. Turn on the mixer.

Make sure the controls on your powered speakers are set the same on both speakers. For example, if you're using subs, and they have a polarity setting, make sure they're both set to the same polarity. Also, if your powered speakers have a Mic/Line setting, make sure they're both set to Line, and if they have their own EQ settings, disable the EQ settings on the powered speakers. Turn the level control knobs on your powered speakers all the way down. Turn on your powered speakers and subwoofers now.

- Now let's create a preset to match your powered speakers. This preset is based on JBL PRX515's and JBL PRX518's for illustration purposes.

Press and hold the SETUP button until "System Setup WIZARD" appears in the display.

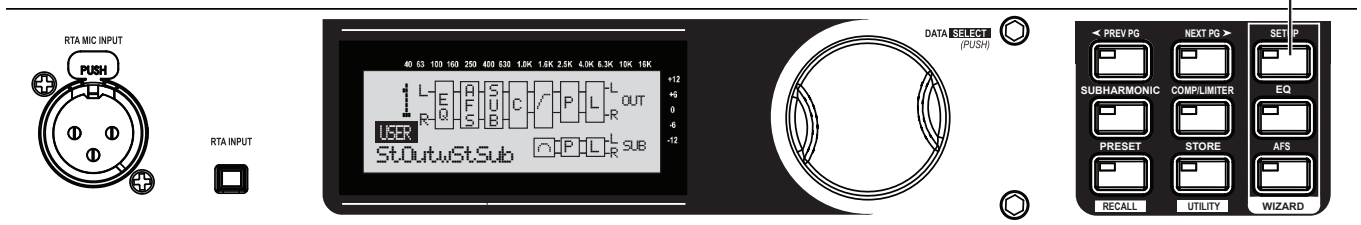

-

Press the NEXT PG button.

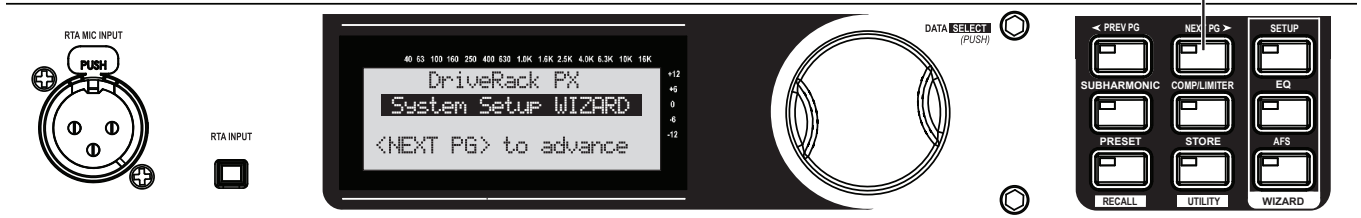

-

- For this example, turn the Data Wheel to select STEREO.
- Press the NEXT PG button.

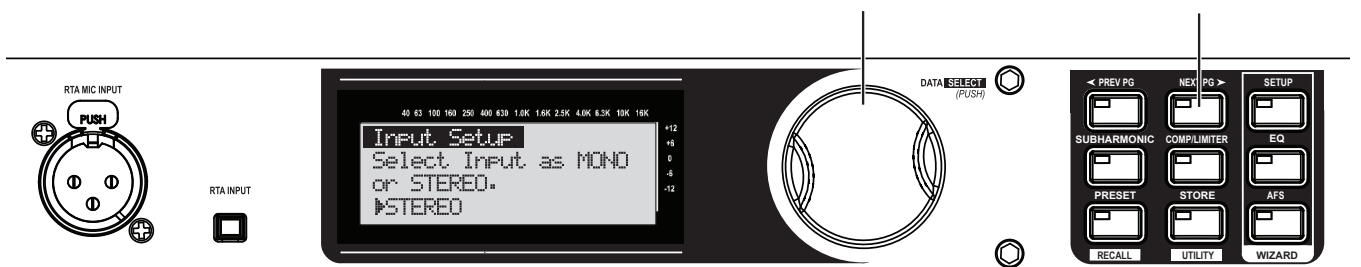

8.

A. Turn the Data Wheel to select your main speakers (for our example, select PRX515).

B. Press the NEXT PG button.

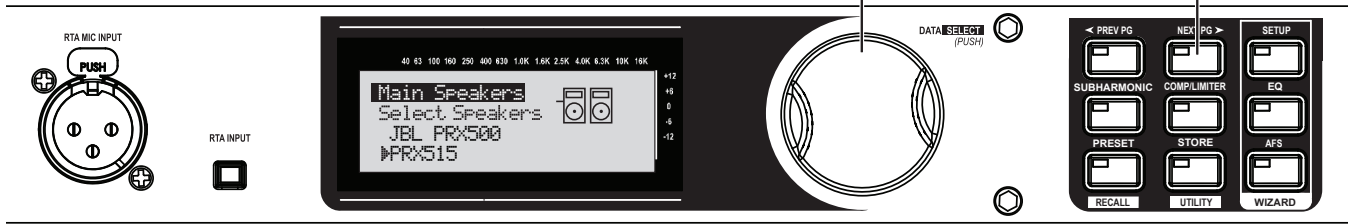

9.

A. Turn the Data Wheel to select your subwoofer speakers (for our example, select PRX518S STEREO).

B. Press the NEXT PG button.

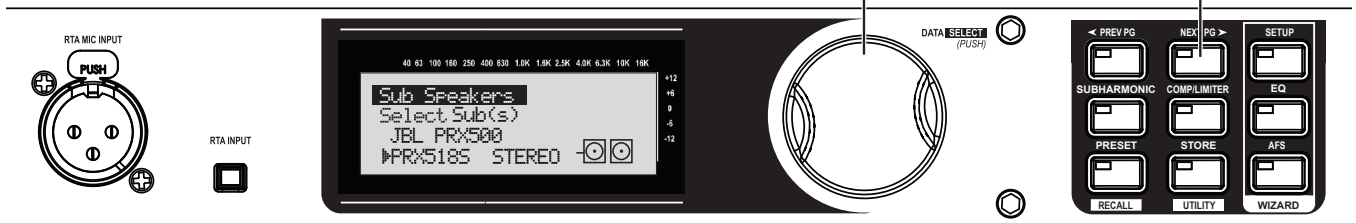

10.

A. Set the level knobs on your main speakers to match the position shown on the display.

B. Press the NEXT PG button.

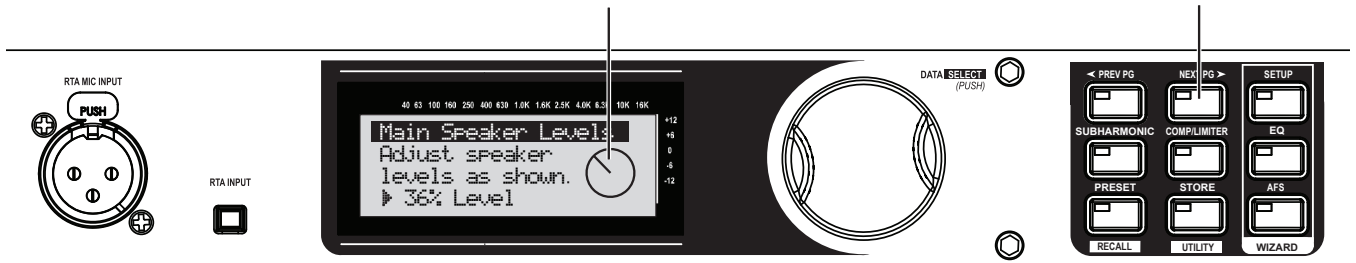

(Note that you also have the option to turn the Data Wheel to adjust the level shown on the display to match a preferred setting on your speakers.)

11.

A. Set the level knobs on your subwoofer speakers to match the position shown on the display.

B. Press the NEXT PG button.

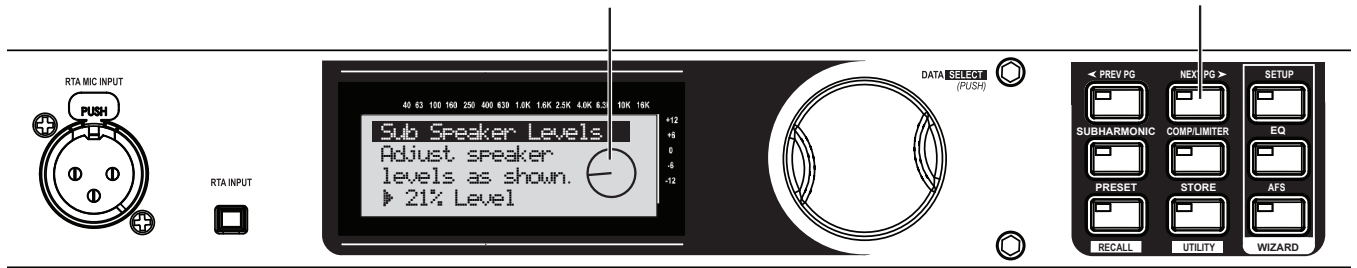

(Note that you also have the option to turn the Data Wheel to adjust the level shown on the display to match a preferred setting on your speakers.)

12.

Press the Data Wheel to load the preset you just created.

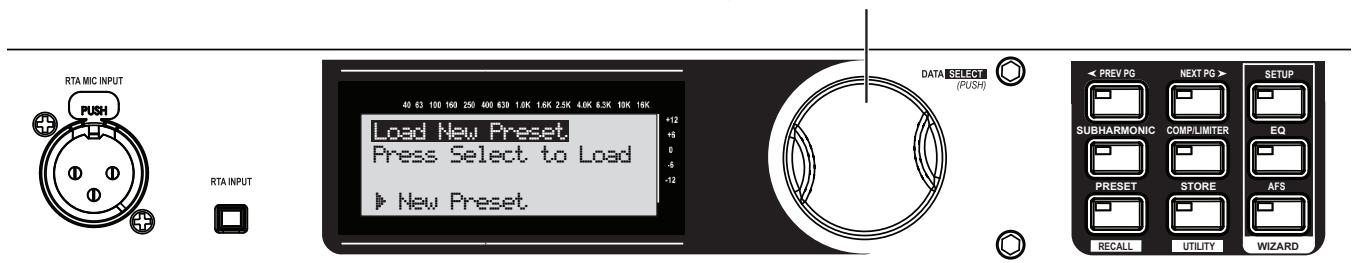

13.



A. Connect the included dbx M2 RTA mic to the RTA MIC INPUT using an XLR cable at least 25' long.

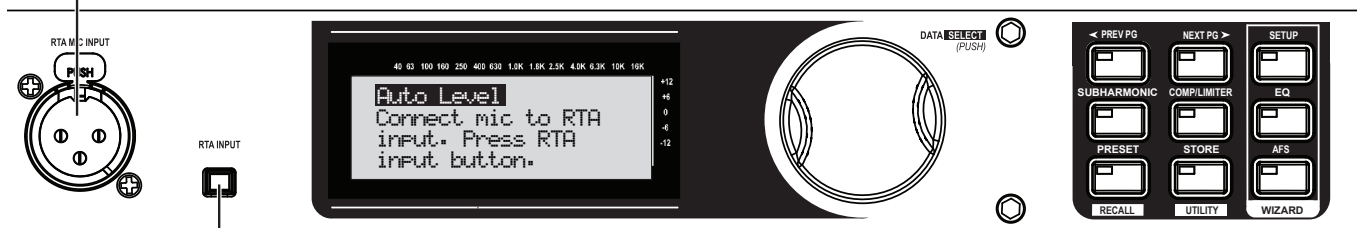

B. Press the RTA INPUT button.

14. With the RTA mic connected, place the RTA mic on a mic stand and aim it between the left and right main speakers approximately 25' away.

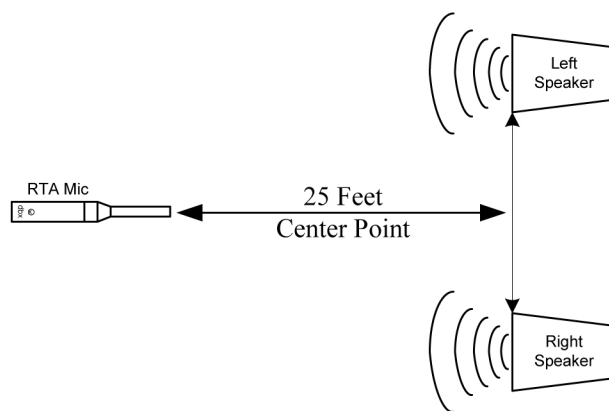

15. Turn the Data Wheel until pink noise is playing through your speakers at performance level (the same volume you intend to use during your performance). The words "SET TO PERFORMANCE LEVEL" will appear in the display when you have passed the minimum threshold. Set level higher as needed.

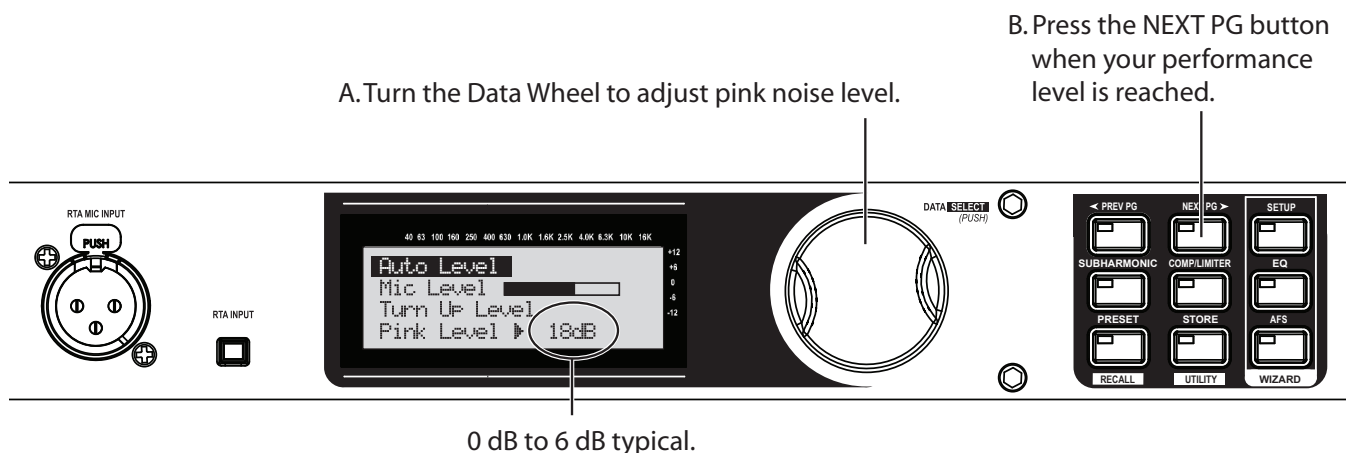

When performance level is reached, press the NEXT PG button. The DriveRack PX will now adjust the balance between left/right levels for your main speakers (and your subs, if you have them). Note that you may be prompted to readjust your speaker knob settings if needed.

16. When the display reads "Auto Level Complete," release the RTA INPUT button.

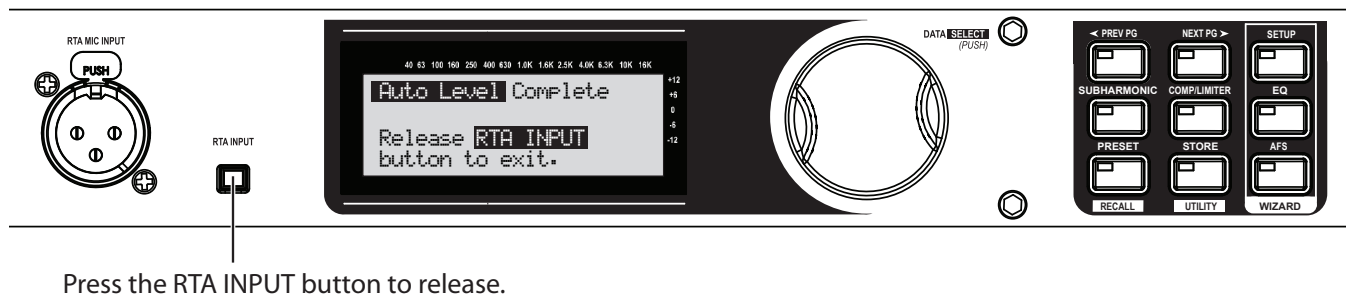

17.

Press the NEXT PG button.



18. Now the Auto-EQ wizard will begin.

Press the NEXT PG button.

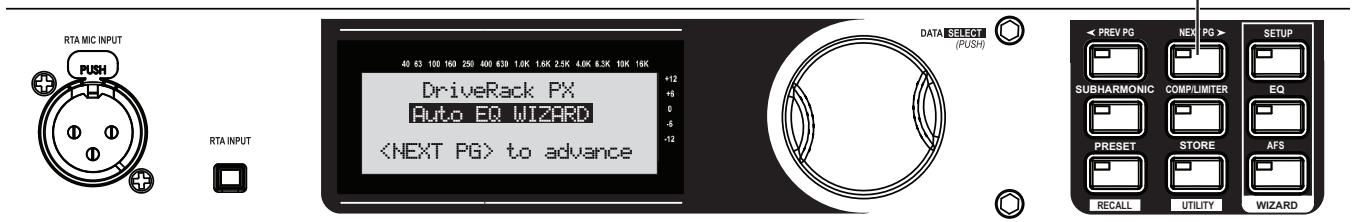

19. With the RTA microphone still connected and in the same position as in step 14, press the RTA INPUT button.

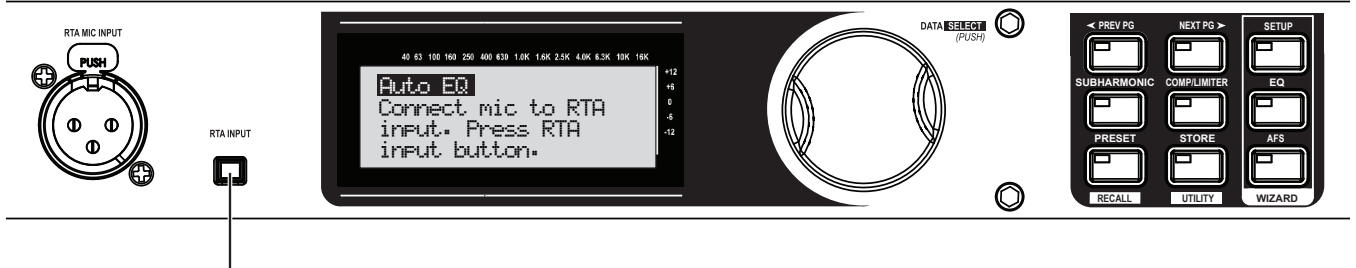

Press the RTA INPUT button.

20. Turn the Data Wheel to select a frequency response for the Auto-EQ. For our example, select Response C. Then press the <Next pg> button to continue. Auto-EQ will match the curve selected.

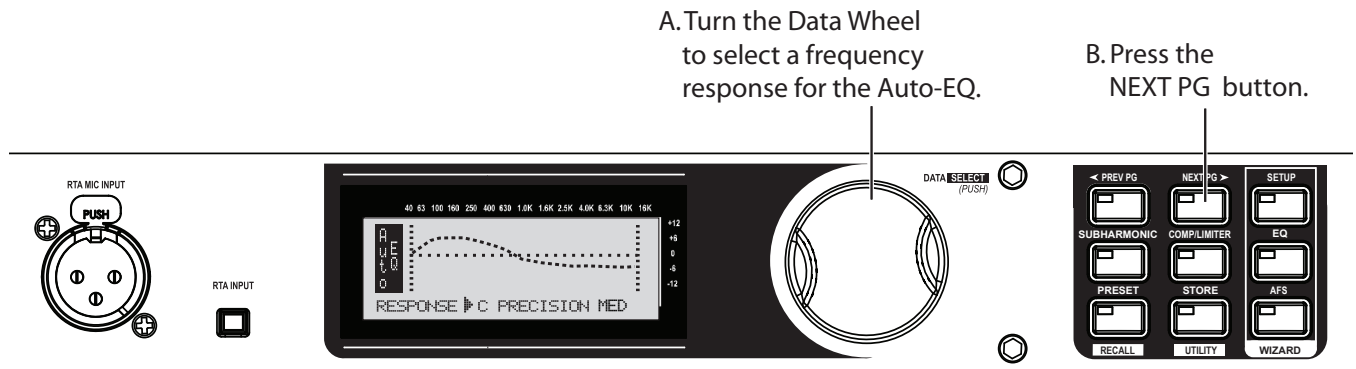

21. Turn the Data Wheel until pink noise is playing through your speakers at performance level. The words "SET TO PERFORMANCE LEVEL" will appear in the Display when you have passed the minimum threshold. Set level higher as needed. Press the <Next pg> button to continue.

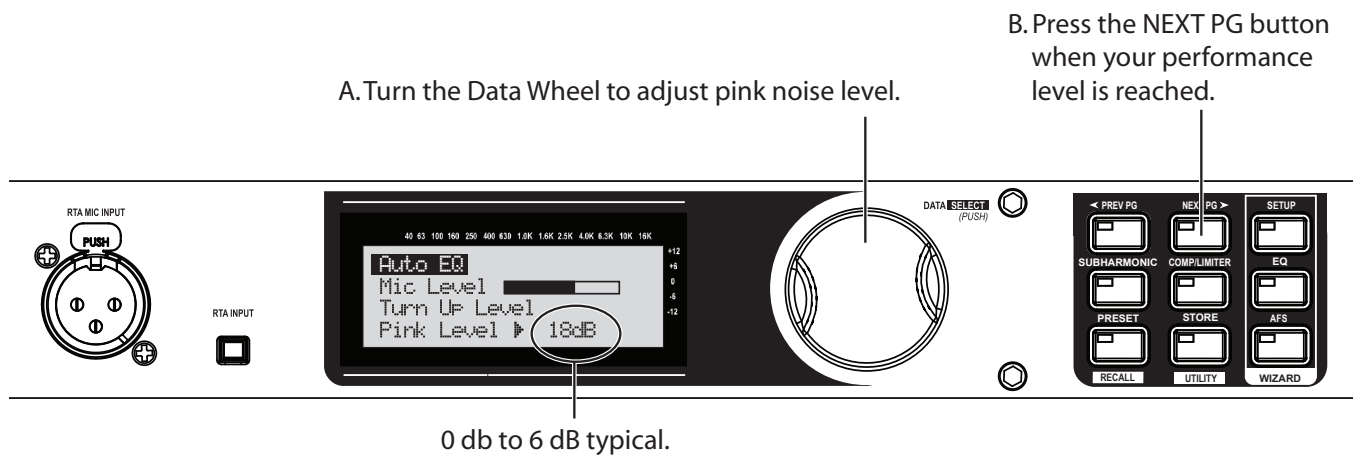

22. The Auto-EQ will go through some audible changes as it tunes the speakers to the room. This may take a few minutes.

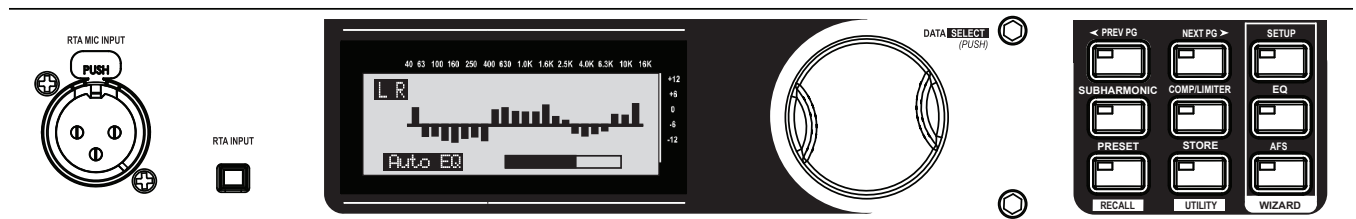

23. Auto-EQ will complete or finish sending pink noise once it has come as close as possible to matching the Frequency response you selected earlier. Press the RTA INPUT button to release it and continue on to the AFS wizard.

NOTE: If the Auto-EQ doesn't complete after several minutes, you may need to press the RTA INPUT button to release it and continue on the AFS wizard. You can do this during the Auto-EQ process, or when the Auto-EQ wizard prompts you.

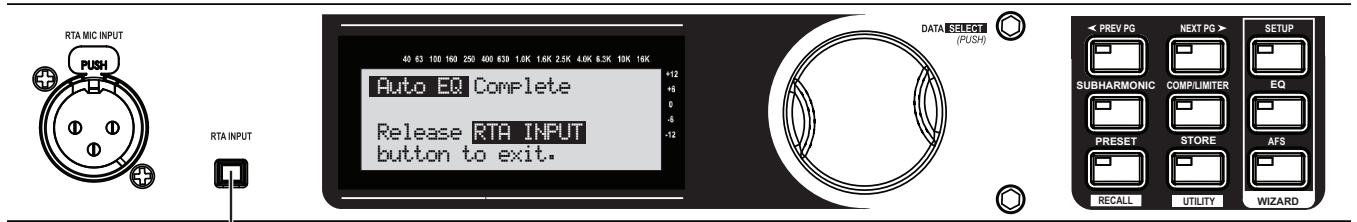

Press the RTA INPUT button.

24. Now the AFS wizard will begin.

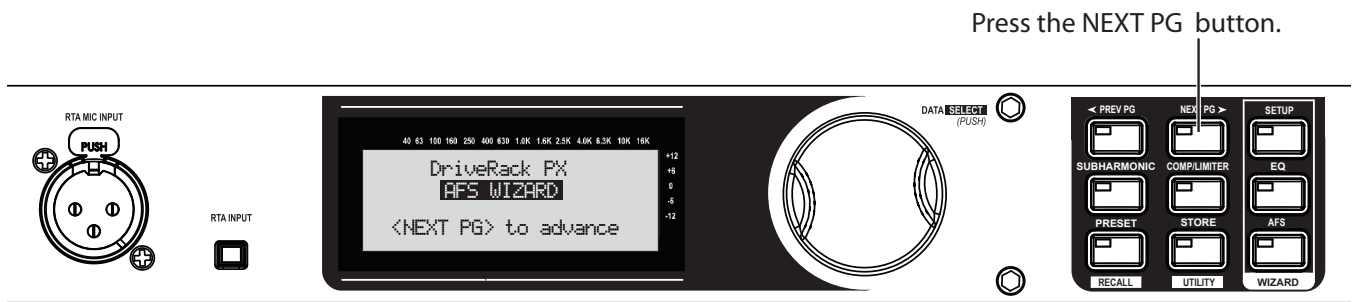

Press the NEXT PG button.

25.

A. Turn down the mixer Master or Main level faders on your mixer.

B. Press the NEXT PG button.

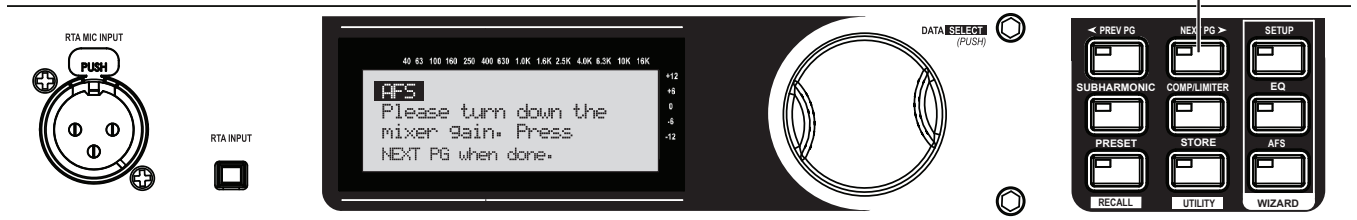

26. Turn the Data Wheel to choose the number of fixed filters to use with Advanced Feedback Suppression. These filters, once populated or FIXED, will stay at the set frequency and level. LIVE “L” filters will change as needed during a performance.

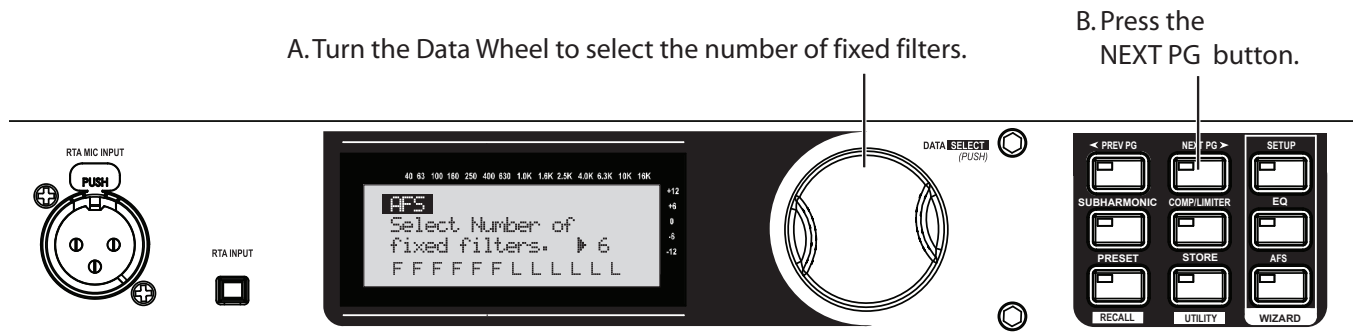

27. Turn the Data Wheel to choose the EQ notch filter width appropriate for your needs. Speech is a wide filter, Music Low is a narrow filter, Music Medium is a very narrow filter, and Music High is an ultra narrow filter. We'll use Music High for our example.

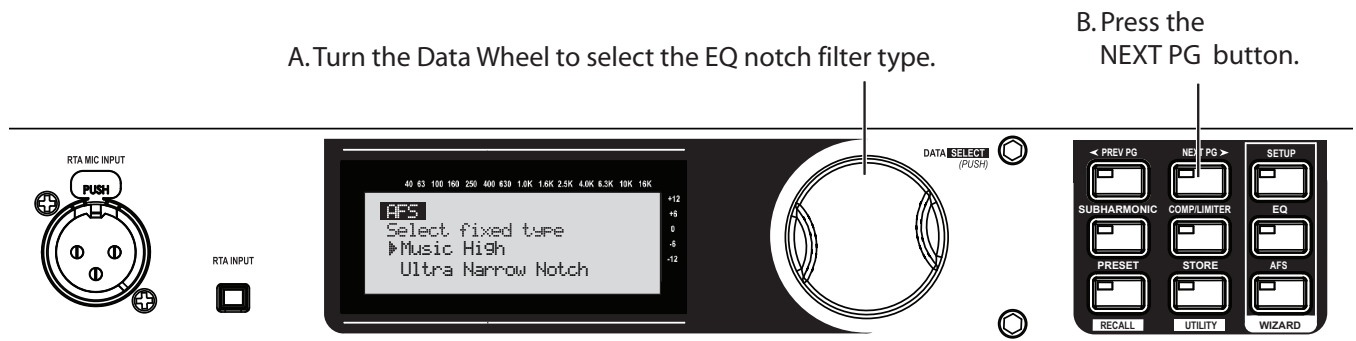

28. With the channel faders down, set the mixer's master level to zero (0 dB). With the microphones you'll be using during the performance in place and connected, turn up microphone channel levels until feedback begins. The AFS will start to populate the Advanced Feedback Suppression fixed filters.

NOTE: Do not talk into any of the microphones or play music. This is only a search for feedback at this point.

A. Slowly increase the channel gain on your mixer to the desired level.



29. Advanced Feedback Suppression has completed when “Fixed Filter Setup Done. In LIVE mode” appears on the Display.

NOTE: Out of control feedback is not advised. Please keep this under control manually with the mixer’s channel or main faders.

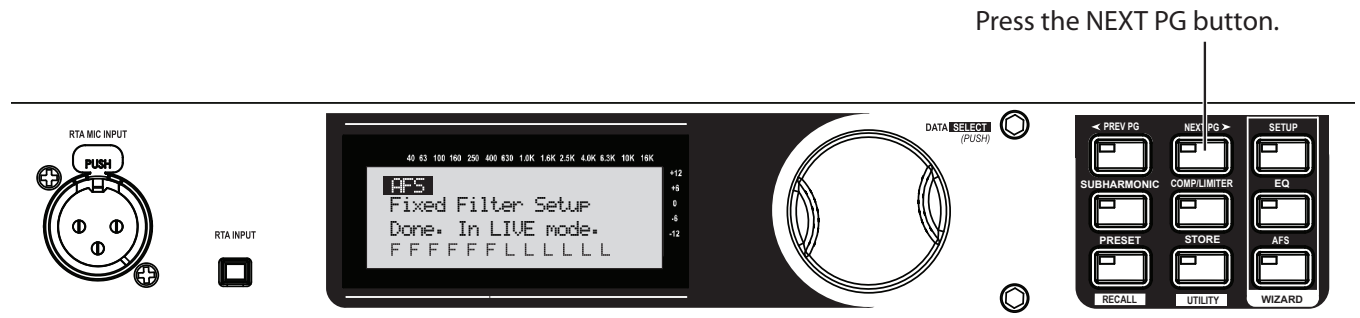

30. Store your new preset by pressing the STORE button.

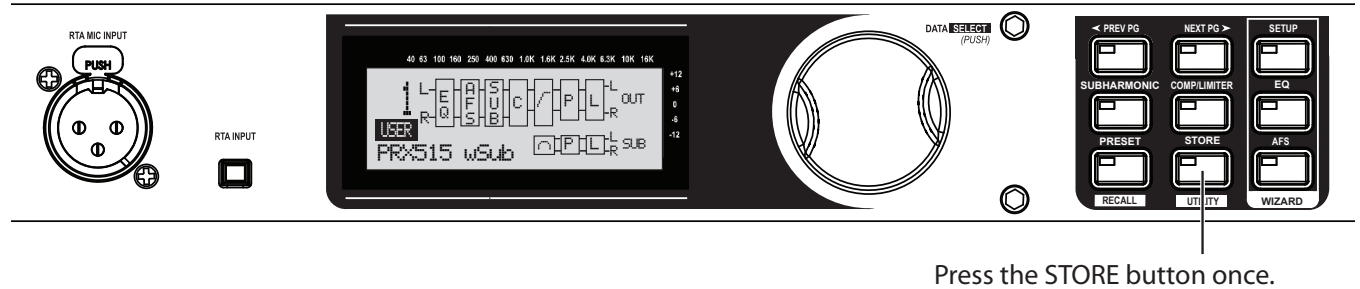

31. Edit the preset’s name. For this example, name it “MY PRESET”.

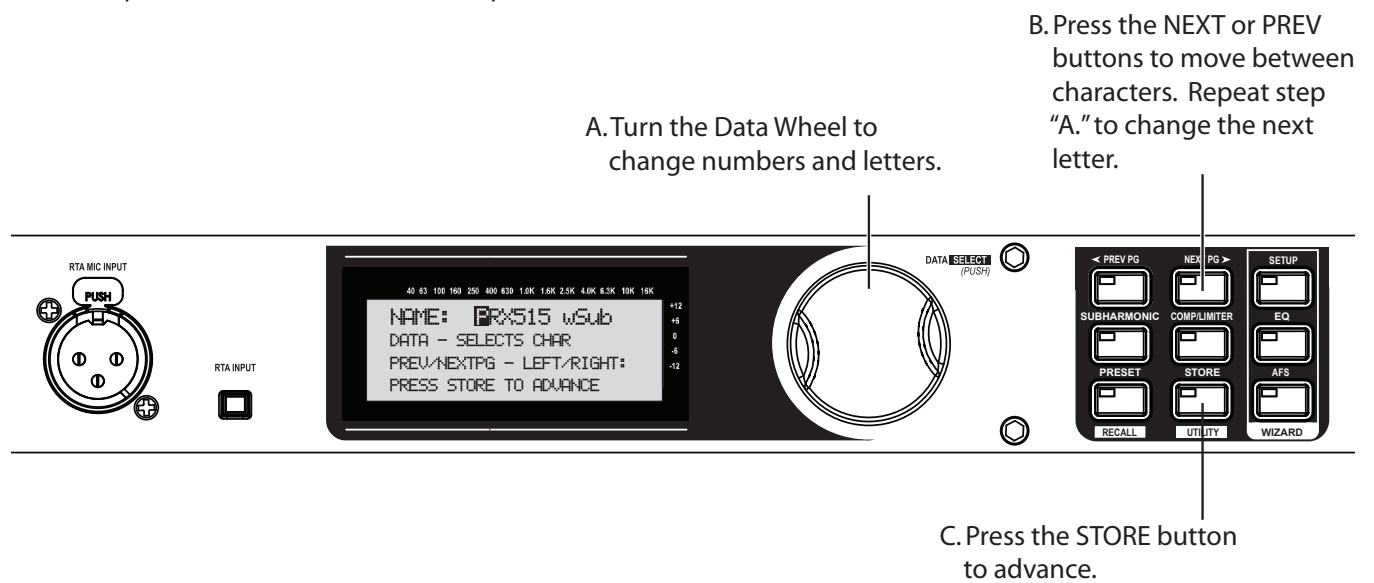

32. Choose the preset's location.

A. Turn the Data Wheel to change the user preset number where your new program will reside.

NOTE: This will replace the program that currently resides in that location.

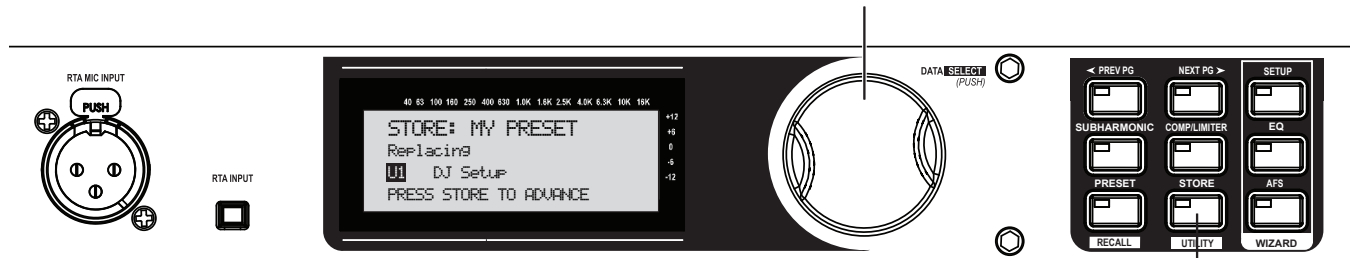

B. Press the STORE button to advance.

33. Your new preset has now been stored. Congratulations and enjoy.

Subsequent Setup - Based on an Existing Preset

1. Remove the DriveRack PX from its box.
 Rack mount the DriveRack PX and connect the power cord.

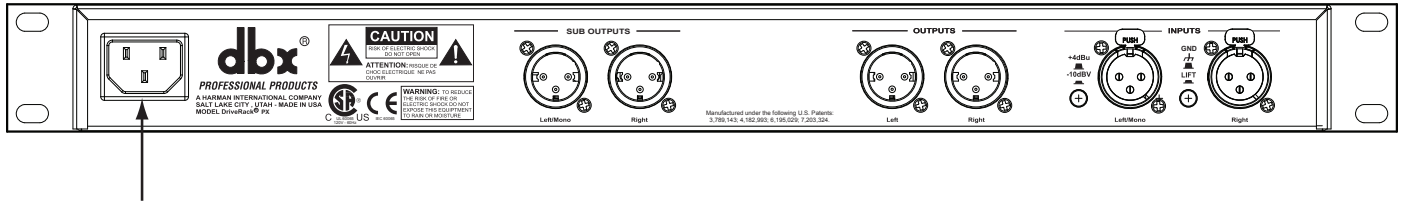

Attach power cord here.

2. Connect the mixer left and right outputs to the DriveRack PX Left/Mono and Right Inputs.

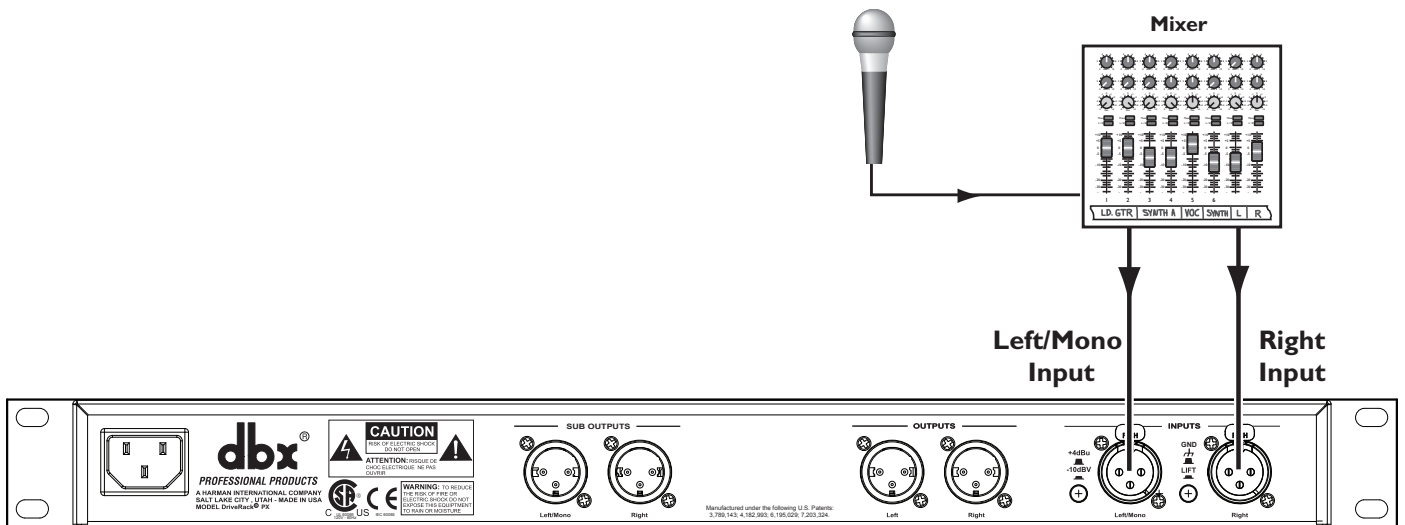

3. Make sure your powered speakers are turned off.

Connect the Left and Right "OUTPUTS" to the left and right main powered speakers.

Connect the Left/Mono and Right "SUB OUTPUTS" to the left and right subwoofers.

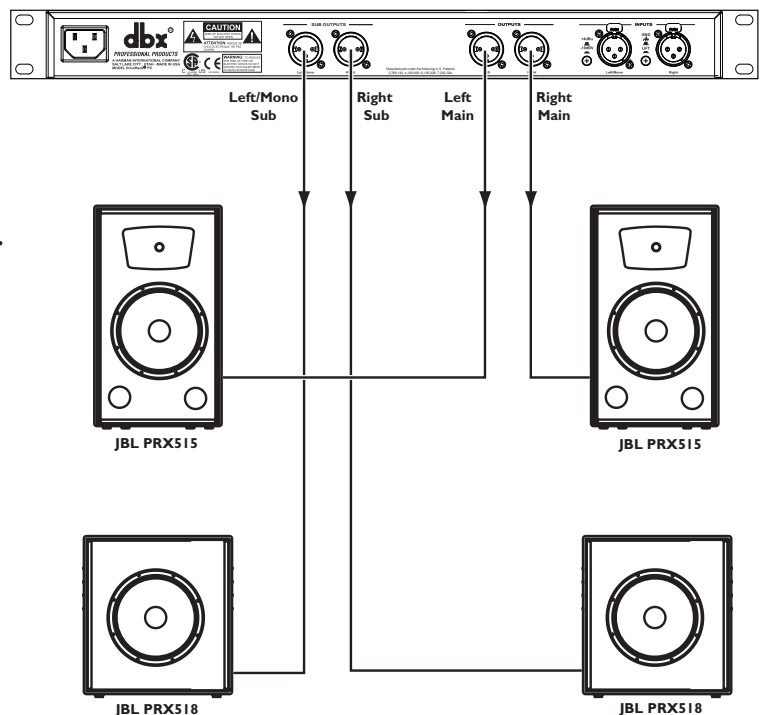

- Turn the mixer master faders down. Turn on the mixer.

Make sure the controls on your powered speakers are set the same on both speakers. For example, if you're using subs, and they have a polarity setting, make sure they're both set to the same polarity. Also, if your powered speakers have a Mic/Line setting, make sure they're both set to Line, and if they have their own EQ settings, disable the EQ settings on the powered speakers. Turn the level control knobs on your powered speakers all the way down. Turn on your powered speakers and subwoofers now.

- Now let's load the preset you created to match your powered speakers (from the first half of this quick start guide).

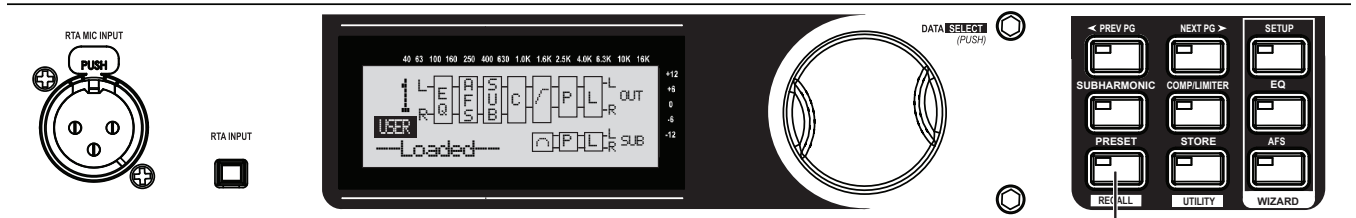

Press and hold the PRESET/RECALL button until "--Loaded--" is flashing in the display.

- Turn the Data Wheel until the preset titled "MY PRESET" appears in the display.

Turn the Data Wheel until MY PRESET appears in the display.

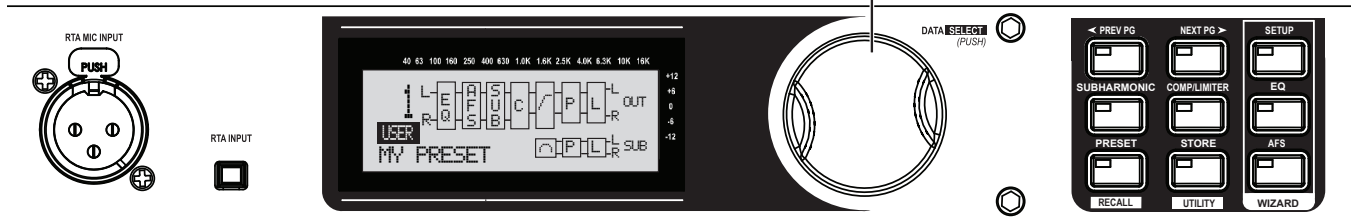

- Press the Data Wheel to load "MY PRESET."

Press the Data Wheel to load MY PRESET

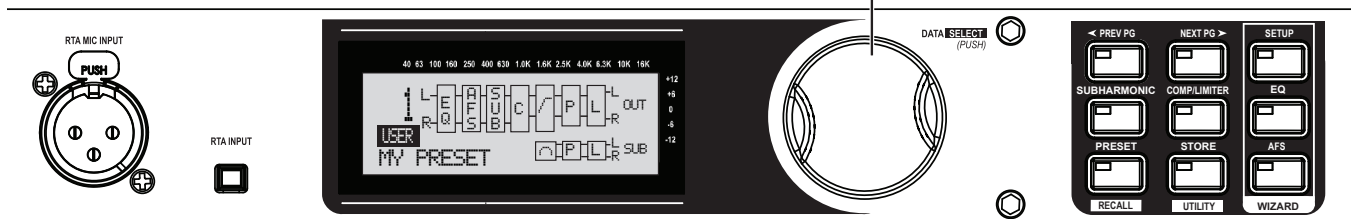

8. Now let's run the System Setup wizard for this preset.

Press and hold the SETUP button until "System Setup WIZARD" appears in the display.

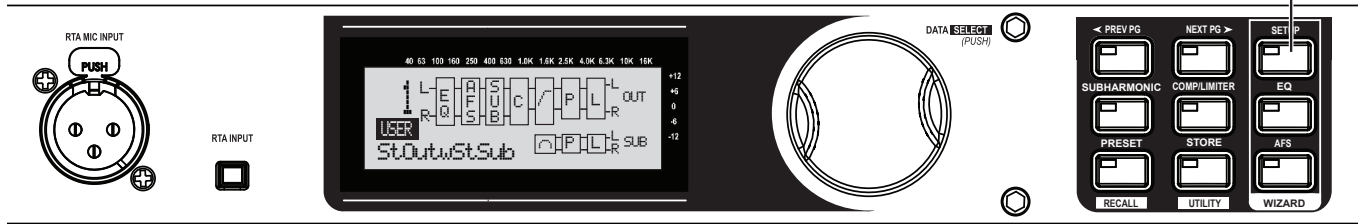

9.

Press the NEXT PG button.

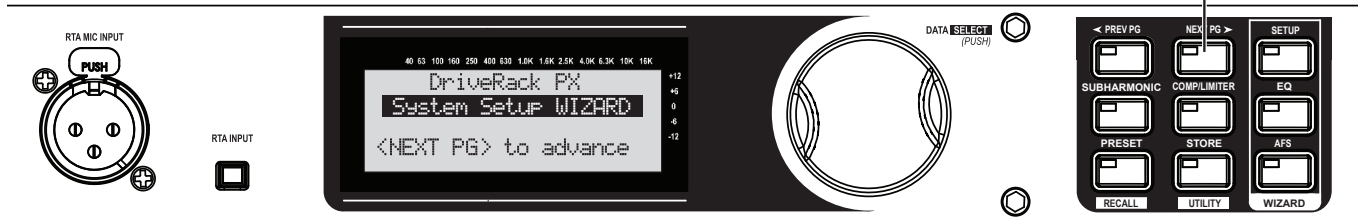

10.

Make sure STEREO is already selected, then press the NEXT PG button.

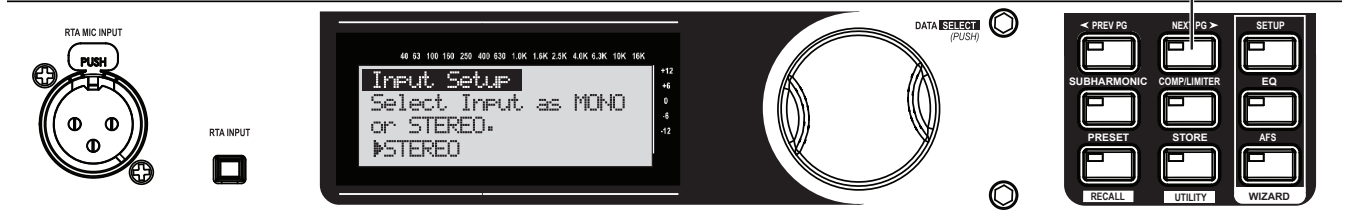

11.

Make sure PRX515 is already selected, then press the NEXT PG button.

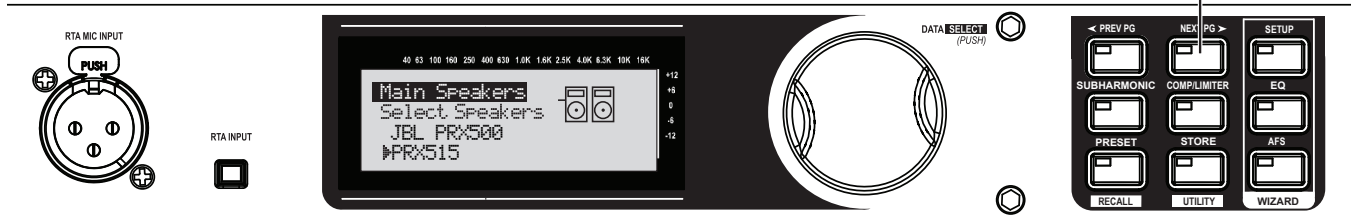

12.

Make sure PRX518S STEREO is already selected, then press the NEXT PG button.

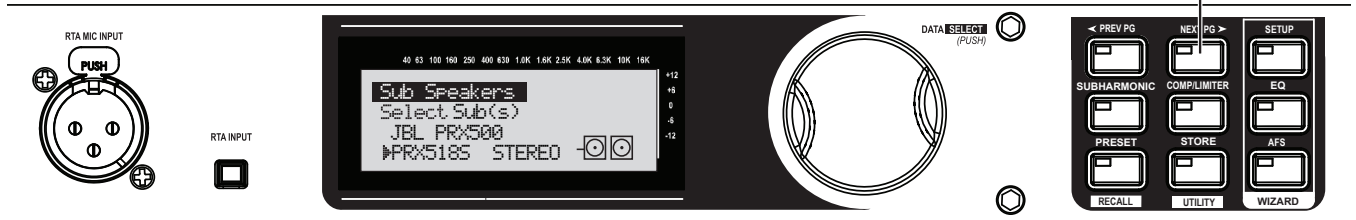

13.

A. Set the level knobs on your main speakers to match the position shown on the display.

B. Press the NEXT PG button.

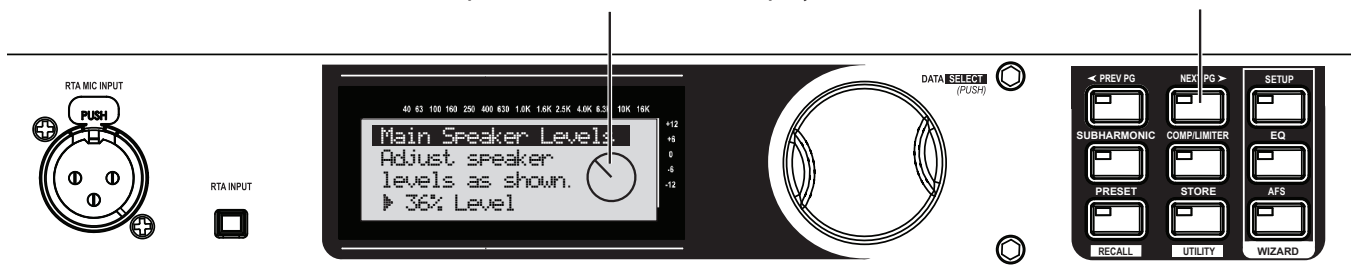

(Note that you also have the option to turn the Data Wheel to adjust the level shown on the display to match a preferred setting on your speakers.)

14.

A. Set the level knobs on your subwoofer speakers to match the position shown on the display.

B. Press the NEXT PG button.

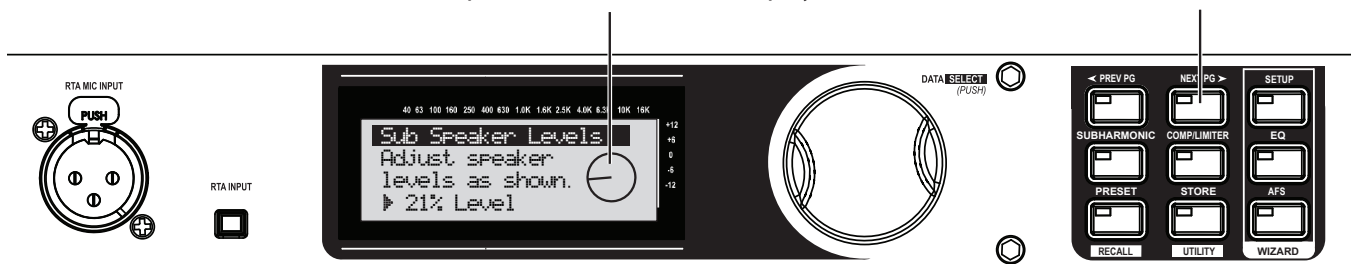

(Note that you also have the option to turn the Data Wheel to adjust the level shown on the display to match a preferred setting on your speakers.)

15. When the display reads “Load New Preset,” connect the RTA mic and press the RTA INPUT button. This will avoid overwriting settings in your existing preset.

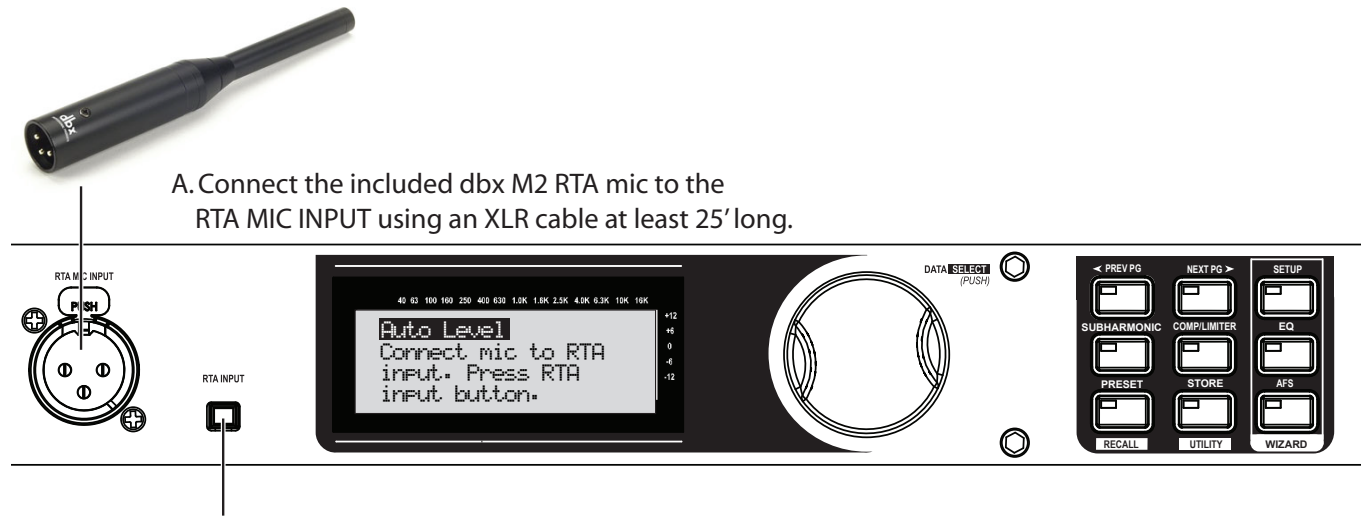

B. Press the RTA INPUT button.

16. With the RTA mic connected, place the RTA mic on a mic stand and aim it between the left and right main speakers approximately 25' away.

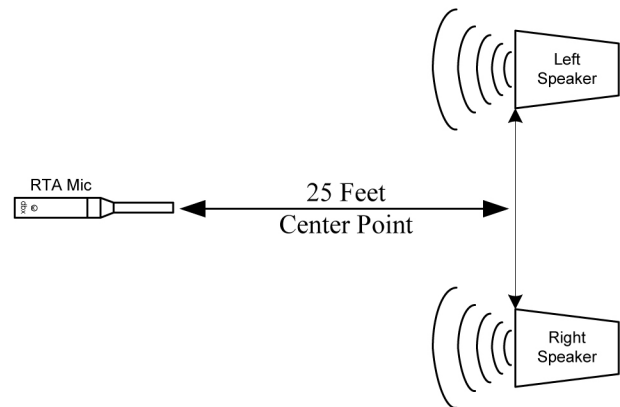

17. Turn the Data Wheel until pink noise is playing through your speakers at performance level (the same volume you intend to use during your performance). The words “SET TO PERFORMANCE LEVEL” will appear in the display when you have passed the minimum threshold. Set level higher as needed.

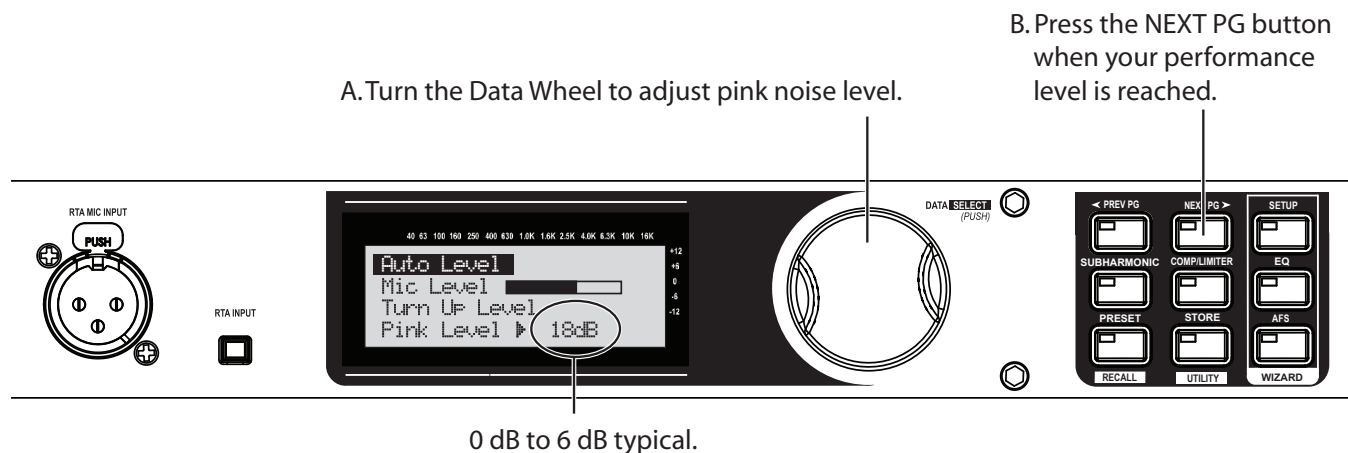

When performance level is reached, press the NEXT PG button. The DriveRack PX will now adjust the balance between left/right levels for your main speakers (and your subs, if you have them). Note that you may be prompted to readjust your speaker knob settings if needed.

18. When the display reads “Auto Level Complete,” release the RTA INPUT button.

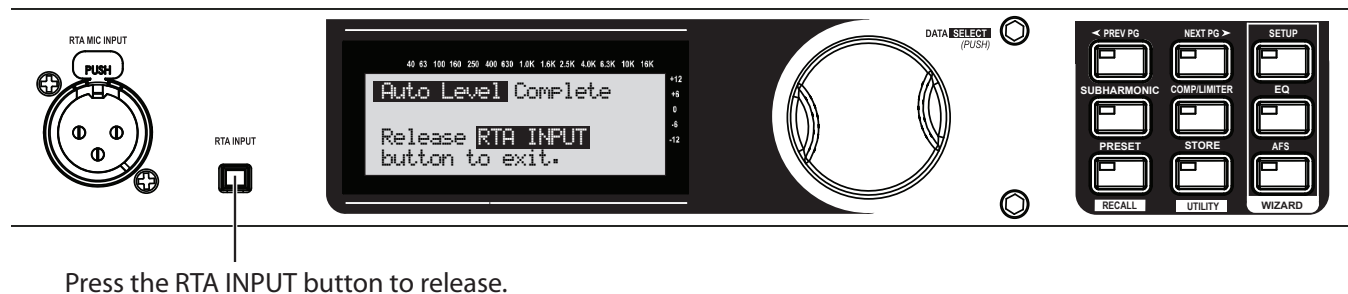

- 19.



20. Now the Auto-EQ wizard will begin.

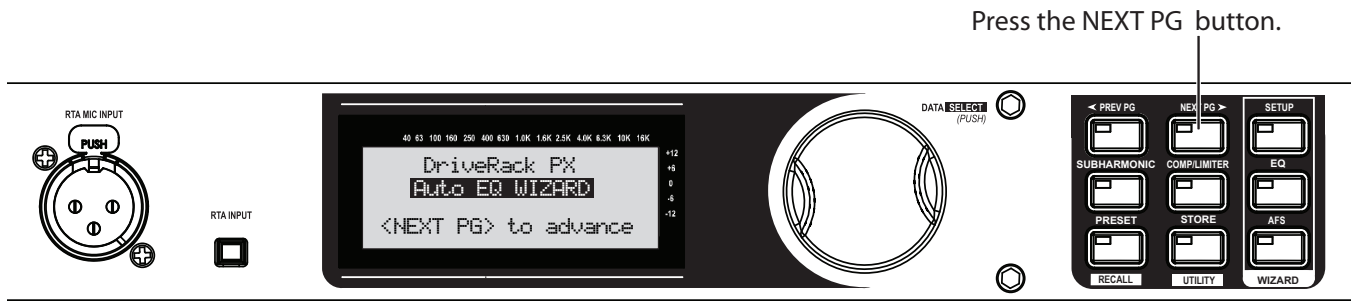

21. With the RTA microphone still connected and in the same position as in step 14, press the RTA INPUT button.

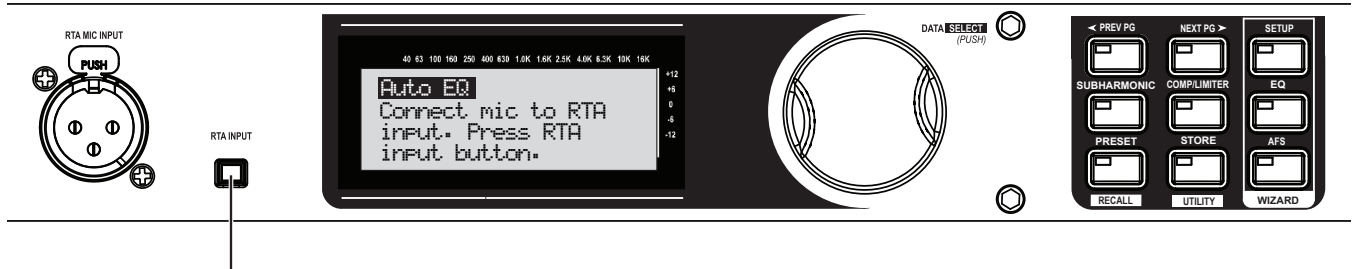

22. Turn the Data Wheel to select a frequency response for the Auto-EQ. For our example, select Response C. Then press the <Next pg> button to continue. Auto-EQ will match the curve selected.

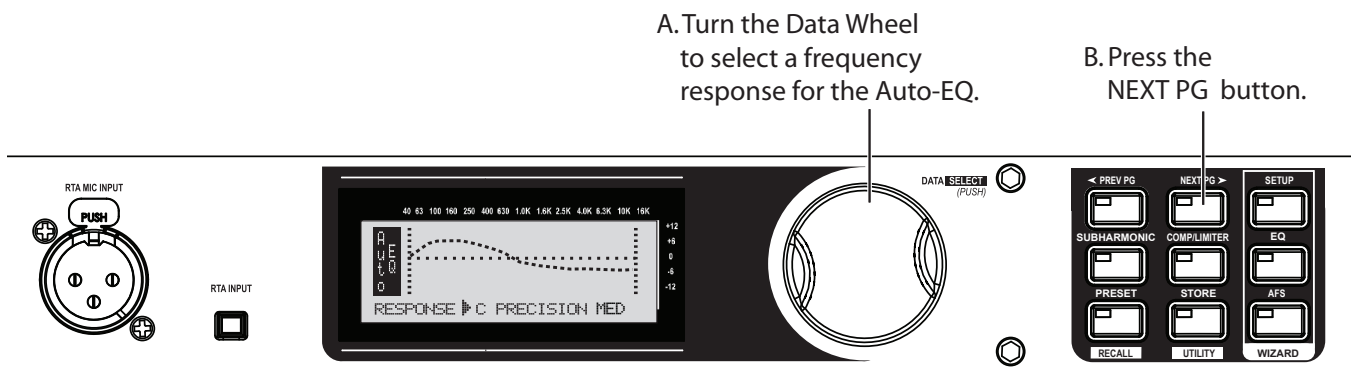

23. Turn the Data Wheel until pink noise is playing through your speakers at performance level. The words “SET TO PERFORMANCE LEVEL” will appear in the Display when you have passed the minimum threshold. Set level higher as needed.

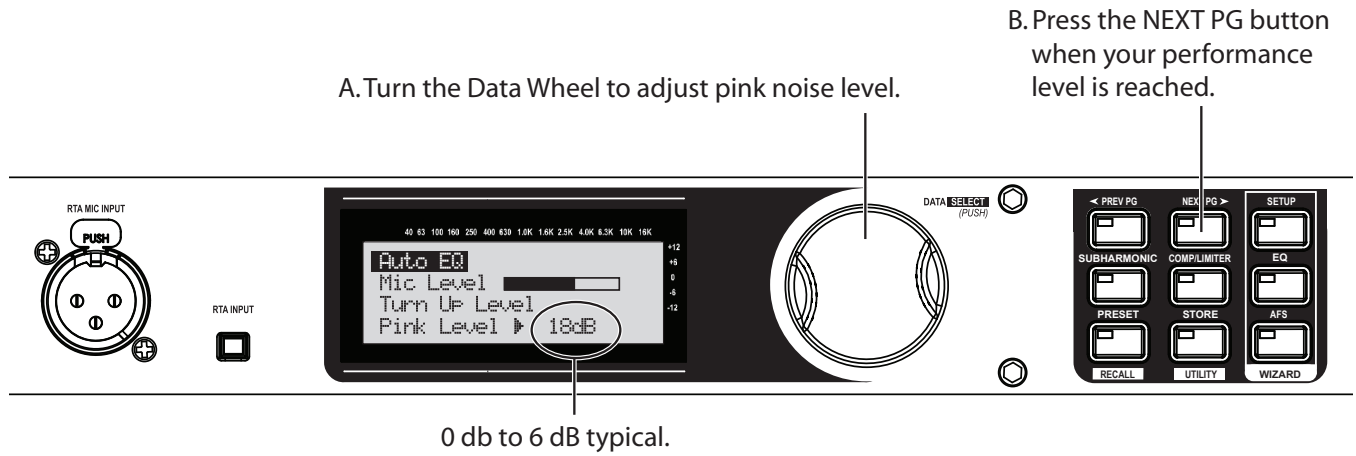

24. The Auto-EQ will go through some audible changes as it tunes the speakers to the room. This may take a few minutes.

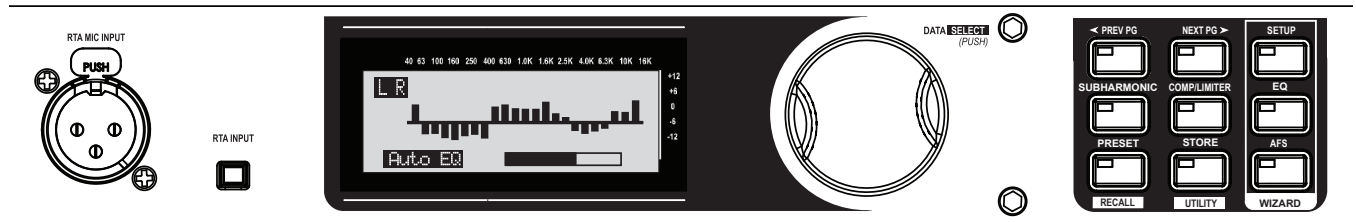

25. Auto-EQ will complete or finish sending pink noise once it has come as close as possible to matching the Frequency response you selected earlier. Press the RTA INPUT button to continue on to the AFS wizard.

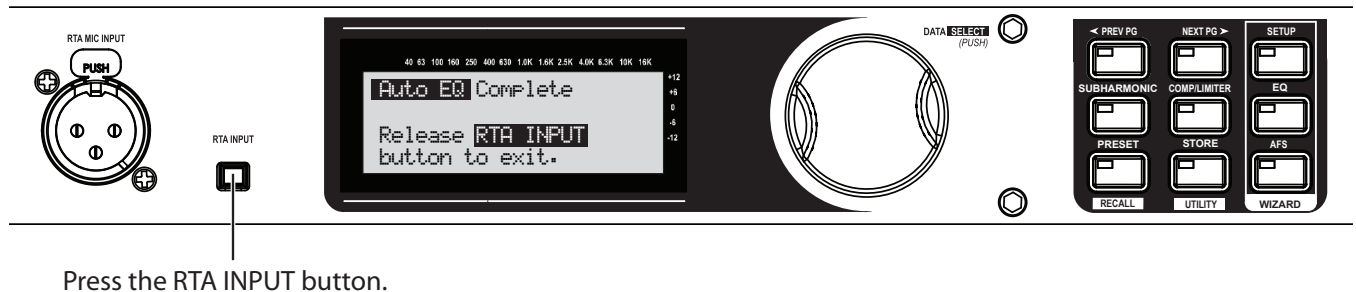

26. Now the AFS wizard will begin.

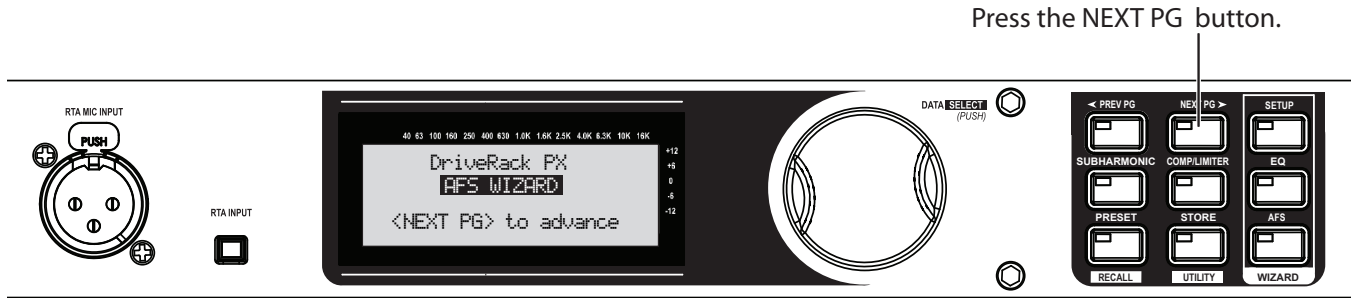

27.

A. Turn down the mixer Master or Main level faders on your mixer.

B. Press the NEXT PG button.



28. Turn the Data Wheel to choose the number of fixed filters to use with Advanced Feedback Suppression. These filters, once populated or FIXED, will stay at the set frequency and level. LIVE "L" filters will change as needed during a performance.

A. Turn the Data Wheel to select the number of fixed filters.

B. Press the NEXT PG button.

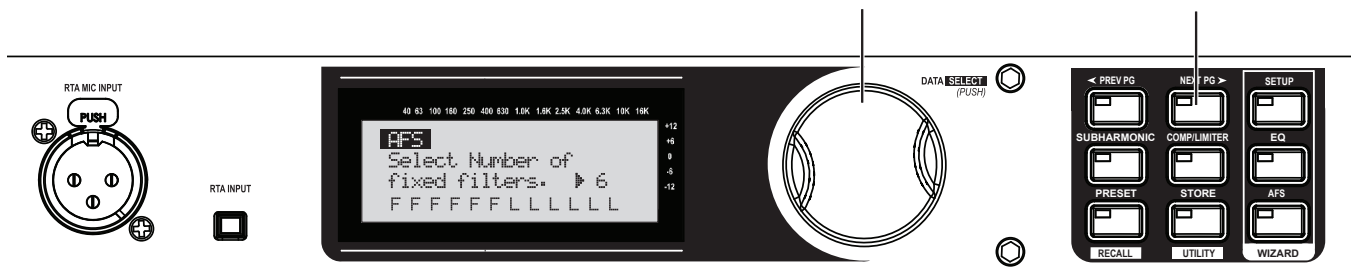

29. Turn the Data Wheel to choose the EQ notch filter width appropriate for your needs. Speech is a wide filter, Music Low is a narrow filter, Music Medium is a very narrow filter, and Music High is an ultra narrow filter. We'll use Music High for our example.

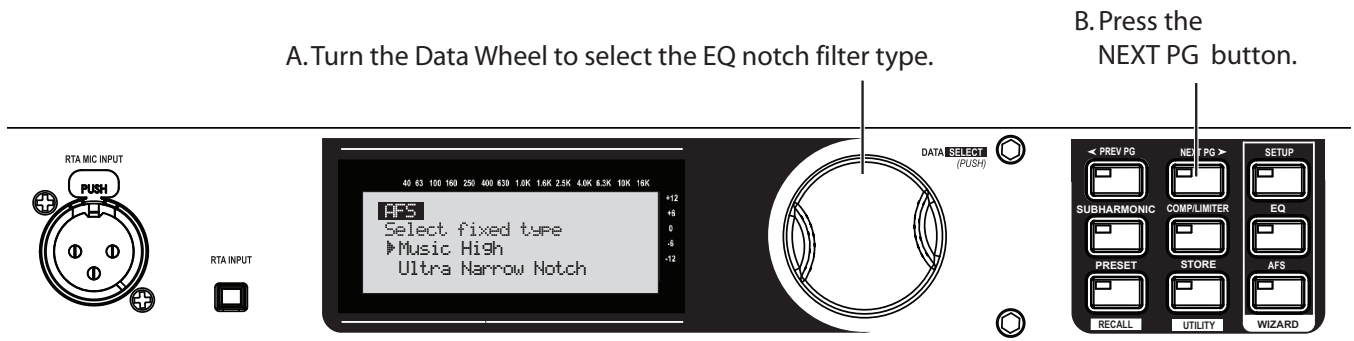

30. With the channel faders down, set the mixer's master level to zero (0). With the microphones you'll be using during the performance in place and connected, turn up microphone channel levels until feedback begins. The AFS will start to populate the Advanced Feedback Suppression fixed filters.

NOTE: Do not talk into any of the microphones or play music. This is only a search for feedback at this point.

A. Slowly increase the channel gain on your mixer to the desired level.



31. Advanced Feedback Suppression has completed when "Fixed Filter Setup Done. In LIVE mode" appears on the Display.

NOTE: Out of control feedback is not advised. Please keep this under control manually with the mixer's channel or main faders.

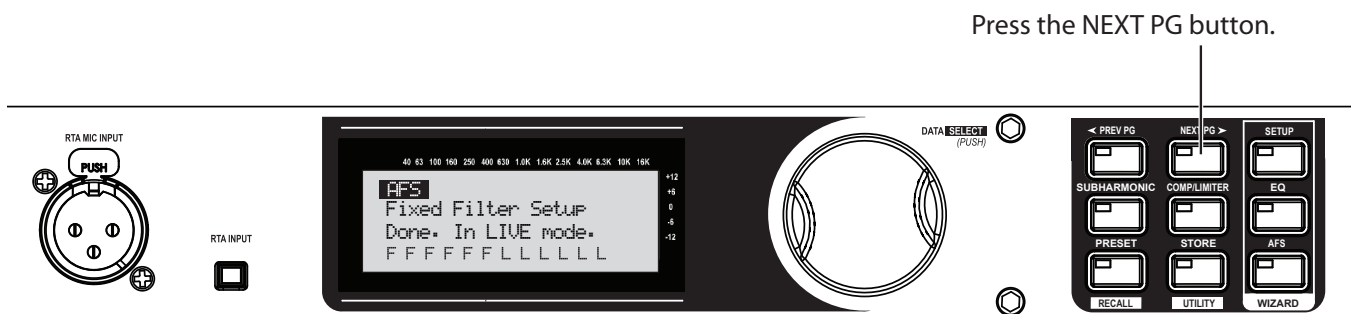

32. Store your new preset (with its same name, and in its current location) by pressing the STORE button three times.

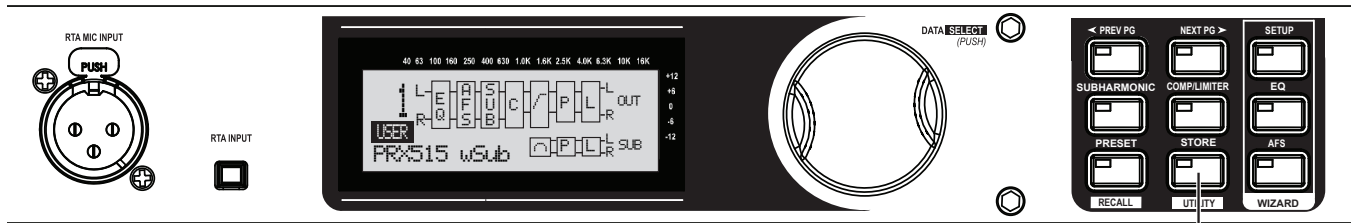

Press the STORE button once.

33. Your new preset has now been stored. Congratulations and enjoy.