



## Pythagorean PEMF:

Remarkable 9.6 Hz / 432 Hz  
Pythagorean & Platonic  
Tuning Harmonics



space age  
performance  
enhancement

# Pythagorean PEMF - Remarkable 9.6 Hz / 432 Hz Factor-9 Tuning Numerology:

432 Hz healing tone: More Pythagorean analysis as a follow up to our first piece [Why 9.6 Hz PEMF ?](#)

Since 2002 the EarthPulse™ has employed a pulsed DC nanosecond rise-time signal with a 50% duty-cycle (on 1/2 the time and off 1/2 the time) that is rich with harmonics. A 9.6 Hz square-wave resonates at 432 Hz at it's 45th harmonic. Pythagorean mathematics would look at 45 as  $4 + 5 = 9$ . Remember that.

**"If you knew the power of the 3, 6 and 9, you would have the keys to the universe!"**  
~ Nikola Tesla

Since 2002 our primary use frequency has been 9.6 Hz and we've looked for evidence to support why it seems to outperform the few other systems that offer 10 Hz. This is the final part of a [two part series](#).

**"Factor 9" Grid Built on 432**

C	126	252	304	1008	2016
C#	135	270	540	1080	2160
D	144	288	576	1152	2304
D#	153	306	612	1224	2448
E	162	324	643	1296	2592
F	171	342	684	1368	2736
F#	180	360	720	1440	2880
G	189	378	756	1512	3024
G#	198	396	792	1584	3168
Ab	207	414	828	1656	3312
A	216	432	864	1728	3456
A#	225	450	900	1800	3600

A – Note 432 Hz Tuning / Factor-9 Musical Tuning: Note that all of the 60 individual musical notes in the 2nd octave 432 Hz A-note chart above are divisible by 9; and that the individual numbers / digits of each frequency when added together = 9. In other words, in Pythagorean math 432 Hz A-note would be represented as  $4 + 3 + 2 = 9$ . This remarkably works on all notes in the chart (but 3 or 4 that could be typos). All are musically "in-tune" with the others. Remarkably, 9.6 Hz and / or it's sub harmonics at 4.8 Hz, 2.4 Hz, 1.2 Hz (or to .6 Hz in just a small number of them) also divide equally into each of these 60 tones. Music tuned any-other way, to say C-note 528 Hz or A-note 440 Hz causes this numerical synchronicity to fall apart miserably.

As you work through angles, 2-D geometric shapes, 3-D geometric shapes and finally sacred geometry you'll begin to realise as we do that there is something magical happening here. Some astro-physical-biological law that's being triggered.

## **Babylonian Base 60 Mathematics:**

You may have heard of Base 60 Mathematics or 12 base 60 math. Although it was "invented" by the Sumerian – Babylonians somewhere between 4000 – 7000 years ago in Mesopotamia, we use it every day. It is where we get 60 seconds per minute, 60 minutes per hour and 24 hours per day. We also get 12 months per year, 12 inches per foot, 12 signs in the Zodiac and perhaps even 12 Greek gods and 12 disciples. See this exhaustive [list of Twelve](#).

Although I resisted these kinds of numerological topics as (far) too esoteric for years, even I can't deny the uncanny synchronicity of how these numerical values fit together. And in turn, more specifically how 9.6 Hz PEMF "fits" remarkably into the musical geometry of shapes and their tonal sounds.

## **Factor 9 (Pythagorean) Tuning Based Upon 2nd Octave A-Note Tuned to 432Hz:**

Here's an entertaining and informative video about sacred geometry and what he calls Factor-9 Tuning, where 2nd octave A note = 432 Hz. It is where the chart above is contained. When that A note is tuned at 432 Hz the entire tuning chart is in synchronicity with the universe as defined by Plato's geometry & 3-D geometry as well as by Sacred Geometry; and a surprising number of terrestrial and extra-terrestrial measurements.



## To quickly recap just some facts from my earlier post [Why 9.6 Hz?](#)

Robert C. Beck (blood electrification / colloidal silver / ozonated water) discovered the terrestrial magnetic field resonated at 9.6 Hz back in the late 1940's early 50's by driving a metal rod(s?) into the Earth as an antenna, then hooking it up to an amplifier and then through an oscilloscope (he called it a "frequency counter").

This interview was heard via internet radio broadcast from Beck's lips in 1996 (or as late as 1998... i just recall that Dad was still alive), but i have no idea when the interview was taped. Beck in the interview was explaining his research into Schumann waves and brain wave of Shamans' & Energy Healers' during the development of his Brain-Tuner CES (cranial electric stimulation) system.

Curiously, Beck never exploited his discovery or reported any work with 9.6 Hz (or 10 Hz) electric or magnetic fields.

Infact ancient wind instruments found buried in tombs and caves and Tibetan Bowls have been reportedly found to be tuned to 432 Hz. The base tone in Factor-9 Tuning 432 Hz ( $4 + 3 + 2 = 9$ ) is devisable by 9 ->  $432 / 9 = 48$  ( $4 + 8 = 12$  &  $1 + 2 = 3$ ).

432 Hz is a harmonic of 12 Hz, 9.6 Hz, and each subharmonic at .6 Hz, 1.2 Hz, 2.4 Hz, 4.8 Hz.

$432 / 12 = 36$  ( $3 + 6 = 9$ )  
 $432 / 9.6 = 45$  ( $4 + 5 = 9$ )  
 $432 / 4.8 = 90$  (9)  
 $432 / 2.4 = 180$  ( $1 + 8 = 9$ )  
 $432 / 1.2 = 360$  ( $3 + 6 = 9$ )  
crazy right?

**"If you wish to understand the Universe think in terms of energy, frequency and vibration." ~ Nikola Tesla**

Many esoteric frequency arts refer to 432 Hz as having the beneficial effect on our biological systems Historically, music appears to have been tuned to 2nd A note at 432 Hz After ages (literally) this was systematically standardized to 440 Hz in 1938? Once tuned up by even one Hz the entire numerological synchronicity falls apart miserably Tuning to 528 Hz C-note destroys these numerological relationships as well.

528 Hz happens to be another harmonic of 9.6 Hz. 9.6 Hz creates harmonics at both 432 Hz and 528 Hz simultaneously !!! CRAZY.  
528 Hz is the 55th Harmonic of 9.6 Hz ( $5 + 5 = 10$  &  $1 + 0 = 1$ )

## Beat Frequency & Brain Wave Entrainment:

If you enjoyed the first video this next one put's more emphasis on the effects of music and beat frequency on Brain Wave Entrainment. Brain Entrainment was our goal since early 2001 when the first EarthPulse™ was being designed. We seem to have hit the nail on its head. The EarthPulse™ derives its effects on sleep and mental performance enhancement from these very same Brain Entrainment effects.



## Pythagorean Music as Factor-9 Tuning:

Pythagoras combined music and geometry into what could be called Factor-9 Tuning. If you watched the video above you already understand it's significance. As we look at these tones in the chart, keep Tesla's quote in mind about 3, 6 and 9 being "a key to the Universe".





## "Factor 9" Grid Built on 432

C	126	252	304	1008	2016
C#	135	270	540	1080	2160
D	144	288	576	1152	2304
D#	153	306	612	1224	2448
E	162	324	643	1296	2592
F	171	342	684	1368	2736
F#	180	360	720	1440	2880
G	189	378	756	1512	3024
G#	198	396	792	1584	3168
Ab	207	414	828	1656	3312
A	216	432	864	1728	3456
A#	225	450	900	1800	3600

Take for instance; the very first frequency – Low C at 126 Hz ->  $1 + 2 + 6 = 9$ . And  $126 / 9 = 14$  ( $1 + 4 = 5$ ). O.k. so how does 9.6 Hz fit into 126?  $126 / 9.6 = 13.125$ . So if we look to the lower harmonics of 9.6 Hz and see that  $126 \text{ Hz} / 1.2 \text{ hz}$  (the lower harmonic of 9.6 Hz, in other words the 8th Harmonic of 1.2 =  $1.2 \times 8 = 9.6$ ) is 105 ( $1 + 5 = 6$ ). An interesting side note is that if you take 13.125 ( $126 / 9.6$ ) added in Pythagorean method, you get  $1 + 3 + 1 + 2 + 5 = 12$  or  $1 + 2 = 3$ . You're going to see a lot of 3's, 6's and 9's (and 12's) as we move along.

Lets try 252 Hz ->  $2 + 5 + 2 = 9$  again. And  $252 / 9 = 28$  ->  $8 + 2 = 10$  or 1. And 9.6 Hz?  $252 / 9.6 = 26.25$ . So, it looks like it's close, so we go for the lower harmonic of 9.6 Hz at 2.4 Hz.  $252 / 2.4$  (lower harmonic of 9.6 Hz) = 105 and  $1 + 5 = 6$  again. We'll do  $252 / 1.2$  and see that it is of course 210 or  $2 + 1 + 0 = 3$ .

If we look at even lower harmonics of 9.6 Hz we find we go from 1.2 Hz to .6 Hz and .3 Hz. We'll stop there. Well, one more -> .15 Hz (point15 Hz)  $1 + 5 = 6$ . O.k. so there's definitely some sort of pattern here with 3, 6 and 9. No idea what it means yet other than perhaps why 9.6 Hz seems to outperform competitive PEMF systems. MicroPulse boasts reduced post-surgical recovery by 1/2. In a few reports from clients of our v4, they cut post-surgical recovery by 2/3. One of them had seen no healing in 10

weeks in a hospital of broken in 1/2 pelvis, and he walked around on it at my birthday party with no crutches just 22 days later he left his crutches in the car outside. Not sure how to classify that in terms of healing promotion. See [Spontaneous Tissue Healing](#).

304 is one of the odd numbers in the chart that doesn't add up to nine and doesn't look like it belongs in the chart. It will not resonate with any of the 9.6 Hz or lower harmonics of it. Seems like it could be a typo.

The sum of the numbers in tone 1008 = 9 and  $1008 / 9 = 112$  and  $1 + 1 + 2 = 4$ . And 9.6 Hz?  $1008 / 9.6 = 105$  and  $1 + 5 = 6$ . So at this point, you should be asking yourself why do all these numbers equally divisible by 9 would all be also divisible by 9.6 or it's lower harmonics 4.8, 2.4 and 1.2. Particularly since they don't add up to 9? Perhaps the magic is in how 1.2 Hz is 1/10th of 12. Even so, this can't be a coincidence. You'll find that nearly every number (but perhaps the typos) in the chart above is as such.

The sum of the numbers in 2016 = 9 and  $2016 / 9 = 224$  and  $2 + 2 + 4 = 8$ . And 9.6 Hz?  $2016 / 9.6 = 210$  and  $2 + 1 + 0 = 3$ .

For sake of argument, we'll go through C#; 135 Hz = 9 again and  $135 / 9 = 15$  and  $1 + 5 = 6$ . How about 9.6 Hz?  $135 / 9.6 = 14.0625$ ; so no harmonics there unless you drop to .6 Hz (below our frequency range) and then it divides into 135 by 225 and of course  $2 + 2 + 5 = 9$ .

Take a look at that number 14.0625 as the number of times 9.6 goes into 135 ( $1 + 4 + 0 + 6 + 2 + 5 = 18$  and  $1 + 8 = 9$ ). Hmmmm. Starting to see a pattern here?

Tone 270 Hz = 9 and  $270 / 9 = 30$  (3). How about 270 / 9.6? = 28.125 ( $2 + 8 + 1 + 2 + 5 = 18$  and  $1 + 8 = 9$  again).  $270 / 1.2 = 225$  ( $2 + 2 + 5 = 9$  AGAIN).

Tone 540 Hz = 9 and divided by 9 = 60 (6). And 9.6 Hz?  $540 / 9.6 = 56.25$  not a whole number but interestingly again  $5 + 6 + 2 + 5 = 18$  and  $1 + 8 = 9$  again. Hmmmm. How about 1.2 Hz into 540 = 450 and  $4 + 5 = 9$  AGAIN. Hopefully, you're seeing the pattern. Somehow in geometry and you'll see below in sacred geometry, the number 9.6 Hz and it's sub-harmonics (.6), 1.2, 2.4 & 4.8 Hz fit "into" the pattern surprisingly well. Remarkably well. Stupendously well.

O.k. we'll continue just to the end of the C# tones.

The sum of the numbers in tone 1080 Hz = 9 and  $1080 / 9 = 120$  ( $1 + 2 = 3$ ) and  $1080 / 9.6$  Hz = 112.5 ( $1 + 1 + 2 + 5 = 9$ ) but  $1080 / 4.8 = 225$  ( $2 + 2 + 5 = 9$  yet again).

The sum of the numbers in tone 2160 Hz = 9 and  $2160 / 9 = 240$  ( $2 + 4 = 6$ );  $2160 / 9.6$  Hz = 225 or 9 yet again.  $2160 / 4.8 = 450$  (9 again).  $2160 / 2.4 = 900$  (9). Hmmm.  $2160 / 1.2 = 1800$  ( $1 + 8 = 9$ ). Weird huh?

Enough of that, but random checking of the rest of the numbers yield the same results but for 2 or 3 of them that don't fit into the 9-pattern at all. They could all be typos.

Plato's Geometry and 9.6 Hz:

Common angles in geometry and possible harmonic relationship with 9.6 Hz. Lets remember that 1.2, 2.4, 4.8 Hz are lower harmonics of 9.6 Hz; and that 12 Hz is one 1.2 Hz step higher than 9.6 Hz.

We'll go through the relationship between 9 and these common angles of measurement in Pythagorean style analysis;

$45^\circ = 9$  ( $4 + 5 = 9$  &  $45 / 9 = 5$ )  
 $90^\circ = 9$  ( $9 + 0 = 9$  &  $90 / 9 = 10$ )  
 $180^\circ = 9$  ( $1 + 8 + 0 = 9$  &  $180 / 9 = 20$ )  
 $360^\circ = 9$  ( $3 + 6 = 9$  &  $360 / 9 = 40$ )  
 $540^\circ = 9$  ( $5 + 4 + 0 = 9$  &  $540 / 9 = 60$ )  
 $720^\circ = 9$  ( $9 + 7 + 0 = 9$  &  $720 / 9 = 80$ )

1.2 divides equally into all but  $45^\circ$ . 2.4 divides equally into all but  $45^\circ$  and  $90^\circ$ . 4.8 divides equally into 12 divides equally into all but  $45^\circ$  and  $90^\circ$  as well. 9.6 doesn't divide into any of them but for  $740^\circ$ .

Plato transformed two-dimensional geometry during an investigation of 3-dimensional shapes developed what are called the Platonic Solids. Platonic Solids are constructed of only 3 basic two-dimensional shapes. These 3 shapes are;



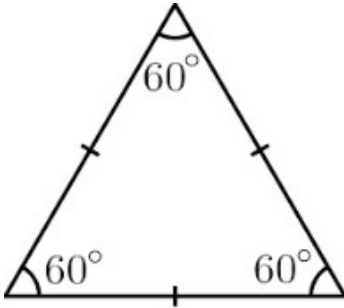

An Equilateral Triangle – where the sum of the internal angles =  $180^\circ$  ( $1 + 8 + 0 = 9$  &  $180 / 9 = 20$  and  $2 + 0 = 2$ )  
 $180 / 2.4 \text{ Hz} = 75$  ( $7 + 5 = 12$  &  $1 + 2 = 3$ ); or by  $12 \text{ Hz} = 15$  ( $1 + 5 = 6$ )

**The Square** – where the sum of internal angles =  $360^\circ$  ( $3 + 6 + 0 = 9$  &  $360^\circ / 9 = 40$  or  $4$ )  $360 / 2.4 \text{ Hz} = 150$  ( $1 + 5 = 6$ ) or by  $4.8 \text{ Hz} = 75$  ( $7 + 5 = 12$  &  $1 + 2 = 3$ ) or by  $12 \text{ Hz} = 30$  ( $3 + 0 = 3$  again)



**The Pentagon** – where the sum of internal angles =  $540^\circ$  ( $5 + 4 + 0 = 9$  &  $540 / 9 = 60$  &  $6 + 0 = 6$ )  $540 / 2.4 \text{ Hz} = 225$  ( $2 + 2 + 5 = 9$ ) or  $12 \text{ Hz} = 45$  ( $4 + 5 = 9$  again)

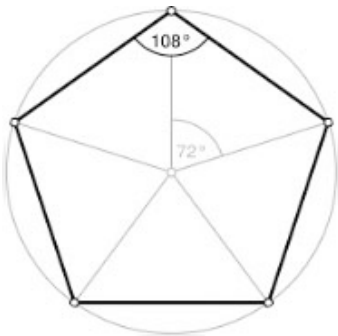

Notice the procession of  $180^\circ$  sum-of-the-internal-angles from shape to shape. That the triangle, the square and pentagon progress at  $180^\circ$  each.



These are the sole 3 shapes that make each of the Platonic Solids discussed below. I continued the numerological dissection of three remaining two-dimensional geometric shapes.

**Hexagon** – where sum of internal angles =  $720^\circ$  ( $7 + 2 = 9$  &  $720 / 9 = 80$ ).

Notice 720 is one more progression of  $180^\circ$   $720 / 9.6 \text{ Hz} = 75$  ( $7 + 5 = 12$  and  $1 + 2 = 3$ );  $720 / 2.4 = 300$  and  $3 + 0 + 0 = 3$ );  $720 / 4.8 = 150$  ( $5 + 1 = 6$ );  $720 / 12 = 60$  ( $6 + 0 = 6$ )



**Octagon** – where the sum of the internal angles =  $1080^\circ$  ( $1 + 8 = 9$ );  $1080 / 9 = 120$  ( $1 + 2 = 3$ )  $1080 / 9.6 = 112.5$  ( $1 + 1 + 2 + 5 = 9$ );  $1080 / 4.8 = 225$  ( $2 + 2 + 5 = 9$ ); and  $1080 / 12 = 90 = 9$ . Notice that this shape is another step of  $360^\circ$ .

**Dodecagon** – where the sum of the internal angles =  $1800^\circ$  ( $1 + 8 = 9$ );  $1800 / 9 = 20$  ( $2$ )  $1800 / 9.6 \text{ Hz}$   $1800 / 4.8 = 375$  ( $3 + 7 + 5 = 15$  &  $1 + 5 = 6$ );  $1800 / 12 = 150$  ( $1 + 5 = 6$ ). Notice that this time there is a step up of  $720^\circ$ .



Notice that ALL of the 6 sums-of-the-angles above (180, 360, 540, 720, 1080 and 1800) are notes in the Factor-9 / 432 Hz Tuning Chart above.

Also take note that sums-of-the-angles in ALL six shapes are divisible by 3, 6, 9 and 12.

**And, that they are all divisible equally by either 9.6 Hz, 4.8, 2.4 or 1.2 Hz. Hmmm...**

## The Platonic (3-Dimensional) Solids and 9.6 Hz:

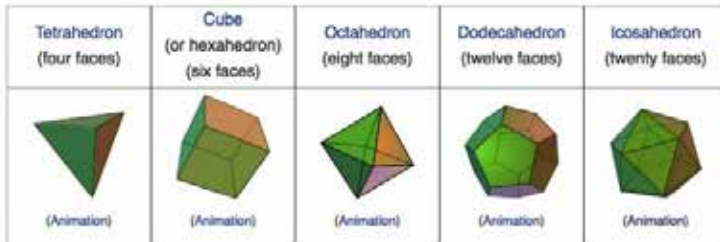

Geometers have studied the mathematical beauty and symmetry of the Platonic solids for thousands of years. They are named for the ancient Greek philosopher Plato who theorized in his dialogue, the *Timaeus*, that the classical elements were made of these regular solids.<sup>[1]</sup>

**Tetrahedron** (4 interlocking triangles) –  $180^\circ$  sum-of-the-internal-angles  $\times 4 = 720^\circ$  ( $7 + 2 + 0 = 9$ );  $720 / 9.6 \text{ Hz} = 75$  ( $7 + 5 = 12$  and  $1 + 2 = 3$ ). 720 represents the 3rd F# in the Factor-9 Tuning chart. It happens to have the same sum-of-the-angles as the Hexagon.

**Cube or Hexahedron** (6 interlocking squares) –  $360^\circ$  sum-of-the-internal-angles  $\times 6 = 2160^\circ$  ( $2 + 1 + 6 + 0 = 9$ );  $2160 / 9.6 = 225$  ( $2 + 2 + 5 = 9$ ). 2160 is the 5th C# in the factor 9 Tuning chart.

**Octahedron** (8 interlocking triangles) –  $180^\circ$  sum-of-the-internal-angles  $\times 8 = 1440^\circ$  ( $1 + 4 + 4 + 0 = 9$ );  $1440 / 432 = 5$ ;  $1440 / 9.6 = 150$  ( $1 + 5 = 6$ ). 1440 is the 4th F# in Factor-9 Tuning chart.

**Dodecahedron** = (12 interlocking pentagons) =  $540^\circ \times 12 = 6480^\circ$  ( $6 + 4 + 8 + 0 = 18$  &  $1 + 8 = 9$ );  $6480 / 432 = 15$  ( $1 + 5 = 6$ ); and remarkably  $6480 / 9.6 = 675$  ( $6 + 7 + 5 = 18$  &  $1 + 8 = 9$  again).

**Icosahedron** (20 interlocking triangles) =  $180^\circ \times 20 = 3600^\circ$  sum of it's internal angles ( $3 + 6 = 9$ );  $3600 / 9.6 = 375$  ( $3+7+5 = 15$  &  $1+5=6$ ). 3600 is the 5th A# in the Factor-9 Tuning chart.

The sum-of-the-internal-angles of each of the Platonic Solids are ALL divisible by 9, divisible by 12 and oddly enough EVERY one divisible by 9.6 Hz! What are the odds of that?

**Metatron's Cube** contains two Tetrahedrons called a Star Tetrahedron and each of the other 3-dimensional shapes discussed above the inside of it.

### Metatron's Cube and 9.6 Hz Harmonics:

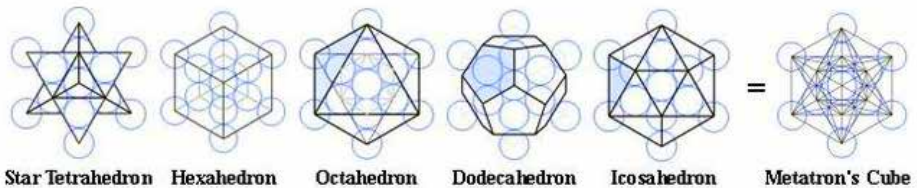

As you can see above for an illustration of the Metatron's Cube we have a Star-Tetrahedron. The Star-Tetrahedron is 2 interlocking regular Tetrahedrons. So, 2x the angles of the Tetrahedron (4 interlocking triangles)  $720^\circ \times 2 = 1440$  (we've seen that number before in the Factor-9 Tuning grid and sum of the internal angles of the Octahedron).

So, the sum-of-the-internal-angles of a Star-Tetrahedron is  $1440^\circ$  ( $1 + 4 + 4 + 0 = 9$ );  $1440 / 9 = 160$ ;  $1440 / 432 = 5$ ;  $1440 / 12 = 120$  (3) and  $1440 / 9.6 = 150$  ( $1 + 5 = 6$ ).



For Metatron's cube, we'd add the 1440° from the Star-Tetrahedron above to the other sums-of-the-angles of the remaining 4 Pythagorean Solids at 2160°, 1440°, 6480°, and 3600° to yield 15120° sum-of-the-internal-angles.

As you can already imagine, 15120 is  $1 + 5 + 1 + 2 = 9$ ;  $15120 / 9 = 1680$  ( $1 + 6 + 8 = 15$  and  $1 + 5 = 6$ ); but how does 9.6 Hz and it's harmonics fit into Metatron's cube?  $15120 / 9.6 \text{ Hz} = 1575$  ( $1 + 5 + 7 + 5 = 18$  and  $1 + 8 = 9$  yet-AGAIN).

Hopefully, you're beginning to see that there is some special relationship of 9.6 into all of this. What other odd decimal number could you come up with that divided into all these numbers as well as 9.6 (or it's lower-harmonic components 4.8, 2.4 and 1.2 Hz)?

## Sacred Geometry and 9.6 Hz:



Genesis Pattern  
(Seed of Life)

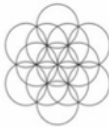

Egg of Life

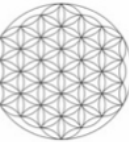

Flower of Life

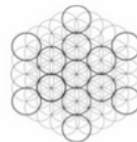

Fruit of Life

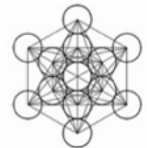

Metatron's Cube

These shapes are all based on circles i.e. 360°; so as you can imagine both 12 Hz and 9 Hz divide into them equally. 9.6 Hz and it's lower harmonics fit as well. And perhaps here the magic in the math is due to 1.2 Hz being 1/10th of 12.

The Germ of Life made up of 6 overlapping circles of 360° = 2160. 2160 is a note in the 5th C# in the Factor-9 Tuning grid.  $2160 / 9 = 240$  ( $2 + 4 = 6$ ); but,  $2160 / 12 = 180$  (equals 9);  $2160 / 9.6 = 225$  (9 Again);  $2160 / 4.8 = 450$  (9 again);  $2160 / 2.4 = 900$  (9 again);  $2160 / 1.2 = 1800$  (9 yet again).



space age  
performance  
enhancement



The Seed of Life or Genesis Pattern = 7 circles at 360 = 2520 (2 + 5 + 2 = 9). Interestingly 2520 is not a tone in the chart.  $2520 / 4.8 \text{ Hz} = 525$  (12 or 3) and  $2520 / 2.4 = 1050$  (6) and  $2520 / 1.2 = 2100$  (3). It does not resonate with 9.6 Hz but does resonate with 12 Hz at its 210th harmonic (2 + 1 = 3).

However, if you put the 7 circles inside a large 8th circle as it is often drawn you get  $360 \times 8 = 2880$ . 2880 is the 5th F# in the Factor-9 Tuning chart.  $2880 / 9.6 = 300$  (3 again); Perhaps this is the way it is meant to be drawn.

The Fruit of Life = 13 circles at 360° = 4680 and  $4680 / 4.8 = 975$  (9 + 7 + 5 = 21 & 2 + 1 = 3 once again)

The flower of life = 19 circles at 360 degrees =  $6840 / 4.8 = 1425$  (1 + 4 + 2 + 5 = 12 & 1 + 2 = 3 yet again)

And if put inside one large circle for a total of 20 circles = 7200° total (7 + 2 = 9);  $7200 / 12 = 600$  (6);  $7200 / 9.6 = 750$  (7 + 5 = 12 and 1 + 2 = 3 again).

## **Some other numerological synchronicities:**

Procession of the equinox or one great year in Mayan Calendar is 25,920 years / 9.6 = 2700 (2 + 7 = 9 AGAIN).

Each of the mayans 12 great months take 2160 Earth years to compete. 2160 is the 5th-octave C#.  $2160 / 9.6 = 225$  (9 again). The diameter of the moon in miles is damn close to 2160 at 2159 (says Google).

There are 43200 seconds in the 12 hours of the day and 43200 seconds in the 12 hours of the night. Added together you have 86,400 seconds in one 24 hour day. And of course, 9.6 Hz divides perfectly into both of those numbers.  $43,200 / 9.6 = 4500$  (4 + 5 = 9 Again) and  $86,400 / 9.6 = 9000$  (9 once again).

How about this one, 432 squared = 186,624 or nearly precisely (with-in .01%) the speed of light as calculated by "modern" science. And of course due to it's uncanny relationship with both Plato's & Sacred Geometry and the terrestrial measurements,  $186624 / 9.6 \text{ Hz} = 19,440$  (1 + 9 + 4 + 4 = 18 / 1 + 8 = 9 yet again).

