

MINI ATV

Read and understand this entire manual before using!

OFF ROAD USE ONLY!!!

INTRODUCTION

Thank you for purchasing this mini ATV. The proper care and maintenance that your vehicle requires is outlined in this manual. Following these instructions will ensure a long trouble-free operating life of this vehicle and your satisfaction with it.

The owner's manual corresponded to the latest state of this vehicle at the time of printing. Slight deviations resulting from continuing development and design can, however, not be completely excluded. All specifications are non-binding, we reserve the right to modify or delete technical specification, parts, design, etc... without prior notice.

SAFETY WARNING

SAFETY WARNINGS

This vehicle is NOT A TOY and ONLY used in closed off areas remote from public road traffic.

Never permit children under age 12 to operate this ATV.

Adult's supervision is required if children under age 16.

WARNING:

Riding an mini ATV can be a hazardous activity. Certain conditions may cause the equipment to fail without fault of the manufacturer. Like other electric vehicles, the Mini ATV can and is intended to move, and it is therefore possible to lose control, fall off and/or get into dangerous situations that no amount of care, instruction or expertise can eliminate. If such things occur you can be seriously injured or die, even when using safety equipment and other precautions. **RIDE AT YOUR OWN RISK AND USE COMMON SENSE.**

This manual contains many warnings and cautions concerning the consequences of failing to maintain, inspect or properly use your mini ATV. Because any incident can result in serious injury or even death, we do not repeat the warning of possible serious injury or death each time such a possibility is mentioned.

APPROPRIATE RIDER USE AND PARENTAL SUPERVISION

This manual contains important safety information and use tips to help you and your child operate and handle the mini ATV. Carefully read the manual in its entirety together with your child before letting your child ride it for first time. The manual also contains important information on servicing the vehicle.

It is your responsibility to review the manual and make sure that all riders understand all warnings, cautions, instructions and safety topics and assure that the riders are able to safely and responsibly use this product and protect your child from injury. We recommend that you periodically review and reinforce the information in this manual with your child, and that you inspect and maintain your children's vehicle to insure their safety. **The recommended rider age of 12 years** is only an estimate, and can be affected by the rider's size, weight or skills. Any rider unable to fit comfortably on the mini ATV should not attempt to ride it.

It is important and necessary to conduct the technical training for your child before first use. To get the training information, please contact the dealer who you purchase the vehicle from. Before your child complete the training, do not let your child use this vehicle.

Children often underestimate or fail to recognize the dangerous situation, you should make it clear to your child that should not, under any circumstances, operate the vehicle without supervision and that your child may only drive at speed that are commensurate with the child's riding ability and other road condition.

A parent's decision to allow his or her child to ride this product should be based on the child's maturity, skill and ability to follow rules.

Keep this product away from small children younger than age 12 and remember that this product is intended for use only by persons who are, at a minimum, completely comfortable and competent while operating the vehicle

ACCEPTABLE RIDING PRACTICES AND CONDITIONS

Always check and obey any local laws or regulations which may affect the locations where the Mini ATV may be used.

PROHIBIED ITEMS

- ★ Do not touch the brakes or engine when the ATV is in use as they can become very hot.
- ★ This vehicle should use mixture of the unleaded gasoline and the two cycle engine oil. The volume ratio is 25:1. Do not use any degraded fuel (which smells sour) or fuel of wrong mixture ratio. It will cause a poor start, insufficient output r damage the engine.
- ★ Do not use 4 cycle engine oil. (Otherwise, it causes the plug to be degraded, the piston ring to seize or the muffler to be clogged)
- ★ Do not run the engine in a room or poor ventilated area. (the exhaust gas includes odorless but hazardous carbon monoxide.)
- ★ Do not put your fingers and other body parts near to the drive chain, steering system, wheels and all other moving components.

- ★ Do not store, spill or use any gasoline near afire, stove, oven, boiler or other instruments which uses a pilot light or spark. (Otherwise, it may cause an explosion.)
- ★ Smoking is strictly prohibited while refilling the fuel
- ★ While the engine is running or while it remains hot soon after stopping, do not remove the lid of the fuel tank or refill the fuel. (Before o refilling the fuel, stop the engine and cool it down 2 minutes or more.)
- ★ If any gasoline is spilt or smelled or any danger of explosion felt, do not run the engine.
- ★ Do not ride at night or when visibility is limited.
- ★ Never carry passengers or allow more than one person at a time to ride the mini ATV
- ★ Do not check any spark while keeping the spark plug removed.
- ★ Do not run the engine with the muffler or air cleaner cover removed.
- ★ Do not touch any hot muffler or engine part. (Otherwise, it may cause a burn.)
- ★ When the engine runs, do not touch any spark plug cap or high tension cord. (Otherwise, it may cause an electric shock and harm you body.)
- ★ Never hitch a ride with another vehicle.
- ★ Do not ride in raining, snowing day, slippery surface, or unstable due to gravel, sand etc.
- ★ Never use alcohol or drugs before or while operating.
- ★ Do not ride if you weight over 155lbs/70KG.
- ★ You insurance policy may not provide coverage for accidents involving the use of this vehicle. Consulting your insurance agent before using this vehicle.

PROPER RIDING ATTIRE

Always wear proper protective equipment such as an approved safety helmet, elbow pads and kneepads. A helmet may be legally required by local law or regulation in your area. A long-sleeved shirt, long pants and gloves are recommended. Always wear athletic shoes, never drive barefooted or in sandals, and keep shoelaces tied and out of the way of the wheels, motor and drive system.

FAILURE TO USE COMMON SENSE AND HEED THE ABOVE WARNINGS INCREASES RISK OF SERIOUS INJURY. USE WITH APPROPRIATE CAUTION AND SERIOUS ATTENTION TO SAFE OPERATION.



LOCATION OF WARNING STICKER



Sticker A is located on the left front fender.

⚠ WARNING

Improper tire pressure or overloading can cause loss of control.
Loss of control can result in severe injury or death.

Cold tire pressure  

Front: 4.00P.s.i operation pressure 24.00P.s.i Max. inflate
Rear: 4.00P.s.i operation pressure 24.00P.s.i Max. inflate
Max. Loading capacity: 70kg

Sticker B is located in the front of the fuel tank cap

ATTENTION!

FUEL STYLE: LEADLESS PETROL 90# AND
TWO-STROKE ENGINE OIL MIXTURE RATIO 25:1.
PLEASE STOP ENGINE WHEN FILLING PETROL.

	CAUTION FIRE RISK		CAUTION EXPLOSION
---	----------------------	---	----------------------

Sticker C is located on the right front fender

WARNING

Improper use of ATVs can cause SEVERE INJURY OF DEATH

ALWAYS USE AN APPROVED HELMET AND PROTECTIVE
NEVER USE ON PUBLIC ROADS
NEVER CARRY PASSENGERS
NEVER USE WITH DRUGS OR ALCOHOL

NEVER operate:
without proper training or instruction
at speeds too fast for your skills or the conditions on public roads – a collision can occur with another vehicle
with a passenger – passengers affect balance and steering and increase risk of losing control

Always:
use proper riding techniques to avoid vehicle overturns on hills and rough terrain and in turns.
avoid paved surfaces – pavement may seriously affect handling and control.
LOCATE AND READ OWNER'S MANUAL.
FOLLOW ALL INSTRUCTIONS AND WARNINGS.

Sticker D is located on the rear right fender.

WARNING

 **NEVER** operate this vehicle if you are under age 12
Adult supervision and instruction is required to operate this vehicle if you are under age 16

 **NEVER** ride as a passenger.
Passengers can cause a loss of control, resulting in SEVERE INJURY or DEATH

 **NEVER** use on public roads.
OFFROAD use only.

Sticker E is located on the left side of engine

WARNING

Danger of burns The exhaust system gets very hot when the vehicle is driven. Allow the exhaust system to cool down.
Do not touch hot components.

PIN LOCATION



PIN is stamp marked on an aluminum plate that is riveted on the front frame. (see picture 4).
PIN means the Product Identify Number which is unique for each unit.

Inflating the Tires



NOTE:The 6" rear tires are inflated when shipped, but they invariably lose some pressure between the point of manufacturing and your purchase. Always inflate the tires to the correct PSI before first time use.

Please read the specification sheet to get the information of tire pressure.

Using a bicycle-style tire pump to inflate the tire to the PSI indicated on the sidewall of the tire.

Note: The pressurized air supplies found at gasoline stations are designed to inflate high-volume automobile tires. If you decide to use such an air supply to inflate your tires, first make sure the pressure gauge is working, then use very short bursts to inflate to the correct PSI. If you inadvertently over-inflate the tire, release the excess pressure immediately.

Important information of use guider for tire

Note: Tire is the only contact between the vehicle to the road, the safety of various driving activity depends on the small area of tire where contact with the road. Therefore, it is very important to keep the tire in good condition any time and use the correct size and standard tire to replace the old ones.

Guide:

Tire assembly and disassembly

It is strongly recommended that the tire assembly and disassembly should be done by an authorized technician with necessary skills.

Tire inflating pressure

It is very important to keep the tire in proper pressure and check the tire pressure before use. The inflating should be done while the tire is cold.

Tire maintenance

Tire tread depth should be checked regularly. (Shallower tread means less grip of tire). You must stop to use the vehicle if the tire is pierced, disassemble the tire and check it carefully. Tire maintenance should be done by an authorized technician. Tire should be replaced immediately when it is distorted or damaged.

Tire replacement

It is important to use the correct size and standard tire as per our specification (see details in technical specification sheet)

Don't use the used tire if you are not sure its previous service condition.

Tire aging

Tire aging is unavoidable even the tire is not ever used or just used a few times. Tire aging is mainly reflected in the cracked section on side of tire and tire tread, sometimes the tire is distorted as well. The used and aged tire should be checked and confirmed if it is ok to use again by an authorized technician

SAFETY REMINDERS

PRE-RIDE CHECKLIST

Loose Parts

Check and secure all fasteners before every ride. Make sure steering stem clamp bolts are locked properly in place. There should not be any unusual rattles or sounds from loose parts or broken components. If you are not sure, ask an experienced mechanic to check.

Brake

Check the brake for proper function. When you squeeze the lever, the brake should provide positive braking action.

Frame, Fork and Handlebars

Check for cracks or broken connections. Although broken frames are rare, it is possible for an aggressive driver to bash into a curb or wall and wreck and bend or break a frame. Get in the habit of inspecting yours regularly.

Tire Inflation

Periodically inspect the tires for excess wear, and regularly check the tire pressure and re-inflate as necessary. If you get a flat tire, the inner tube can be patched or a new tube can be purchased from an authorized repair shop.

Safety Gear

Always wear proper protective equipment such as an approved safety helmet, elbow pads and kneepads. Always wear shoes (lace-up shoes with rubber soles), never drive barefooted or in sandals, and keep shoelaces tied and out of the way of the wheels, motor and drive system

ATTENTION

We recommend checking all tightenings after the first time use. Special attention should be paid to the following parts:

- Footrest
- Engine sprockets (Racing version only)
- Shock absorber
- Engine bolts and nuts

- Rear sprocket

ECOLOGIC DRIVE

The noise and the pollution of every vehicle depend on how it is driven.

We strongly recommend you to drive steadily, without strong acceleration and deceleration

During off road use, do not damage the environment, avoid noise and everything that can disturb persons and animals.

Use a sport drive only on race circuits.

● **HAND DRIVE CONTROLS**



- 1 rear brake lever
- 2 front brake lever
- 3 stop switch
- 4 Emergency kill switch
- 5 Accelerator lever

● **PRODUCT DESCRIPTION**



- | | |
|----------------------|---------------------|
| 1. front brake lever | 2. rear brake lever |
| 3. handlebar | 4. seat |
| 5. chain cover | 6. mudguard |
| 7. front shocker | 8. bumper |
| 9. fuel tank | 10. kill switch |
| 11. throttle | 12. front brake |
| 13. engine | 14. footrest |
| 15. lock key | 16. rear brake |
| | 17. exhaust |



- | | |
|-----------------------|---|
| 1. front brake lever | 2. rear brake lever |
| 3. handlebar | 4. Battery <i>for Electric start engine</i> |
| 5. chain cover | 6. foot rest |
| 7. front shocker | 8. bumper |
| 9. lock key | 10. steering bar |
| 11. seat | 12. fuel tank |
| 13. kill switch | 14. throttle |
| 15. front tire 4.10-6 | 16. engine |
| 17. chain | 18. rear tire 13x5.00-6 |
| 19. rear shocker | 20. exhaust |

● BEFORE YOU BEGIN

Remove contents from box. Remove the foam separators that protect the components from damage during shipping. Inspect the contents of the box for scratches in the paint, dents or kinked cables that may occur during shipping. Because the product was 85 percent assembled and packed at the factory, there should not be any problems, even if the box has a few scars or dents.

Estimated Assembly and Set-Up Time

We recommend assembly by an adult with experience in motorbike or bicycle mechanics. Allow up to 30-40 minutes for assembly.

Required Tools

Some tools may be supplied; however, we recommend the use of mechanic's grade tools. Use the supplied tools only as a last resort.

The list of tool required is as follows

- Open end wrench 10mm / 13mm/ 17mm / 22mm
- Allen wrench 5mm / 6mm/ 8mm
- Bicycle style tire pump with pressure gauge

Assembly illustration and instruction

ASSEMBLY REAR WHEEL 4"

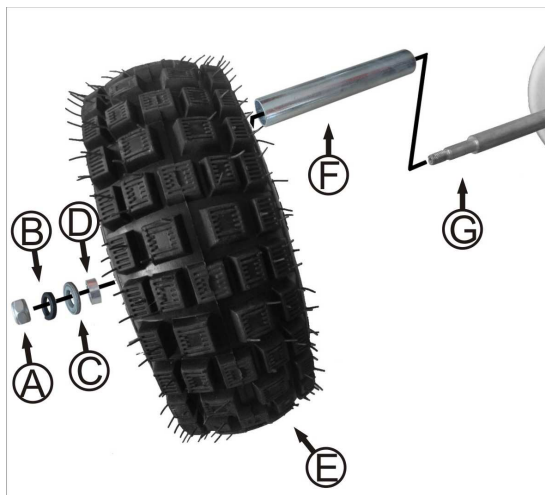

- A: Nut M10 2PCS
- B: Spring Washer $\Phi 10$ 2PCS
- C: Washer $\Phi 10$ 2PCS
- D: Bush $\Phi 22 \times 1.8 \times 139$ 1pcs (Left)
 $\Phi 22 \times 1.8 \times 139$ 1pcs(Right)
- E:Rear wheel 2PCS
- F:Sleeve $\Phi 22 \times 1.8 \times 10$ 2PCS
- G:Rear axle

- 1.Install the sleeve(F) to the rear axle (G).
- 2.Fix the rear wheel (E) through the axle (G).
- 3.Mount the bush(D),flat washer(C),spring washer (B) and nut(A) in sequence, then tighten the nut securely with 17mm open end wrench.

ASSEMBLY REAR WHEEL 6"

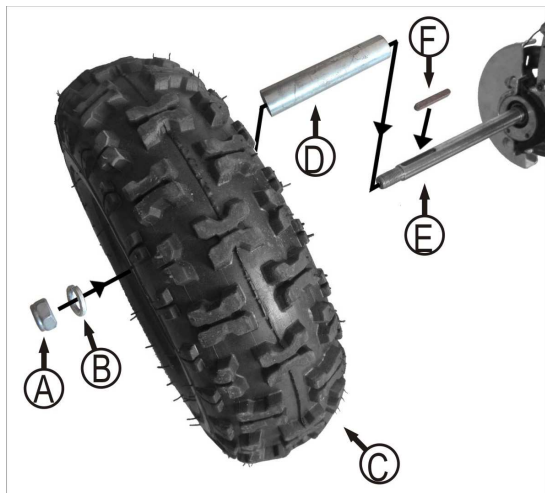

- A: Nut M14 2pcs
- B: Washer $\Phi 14$ 2pcs
- C: Rear wheel
- D: Sleeve $\Phi 22 \times 1.8 \times 112$ 2pcs
- E: Rear axle
- F: Pin 2pcs

1. Install the sleeve(D) to the rear axle (E).
2. Put the pin(F) into the groove on the axle.
3. Fix the wheel(C) through the axle.
4. Mount the spring washer (B) and then tighten the nut(A) securely with 22mm open end wrench.

ASSEMBLY REAR SHOCKER

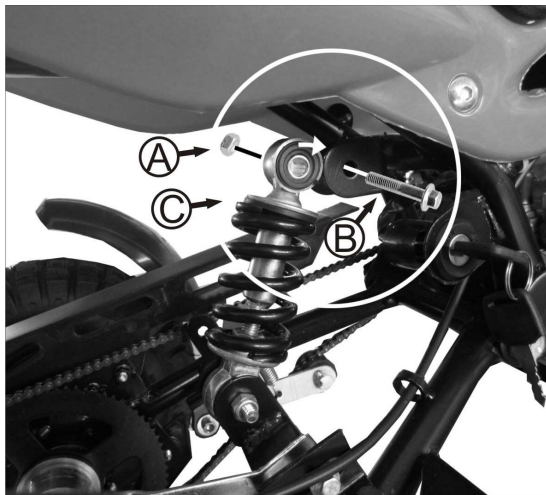

A: Nut M8 1pcs

B: Bolt M8×40 1pcs

C: Rear shock

1. Uplift the frame to align the shock (C) mounting hole to the shackle joint hole.
2. Fix the bolt (B) through the shock mounting hole and shackle joint and tighten the nut (A) securely with 10mm -13mm open end wrench

ASSEMBLY FRONT WHEEL

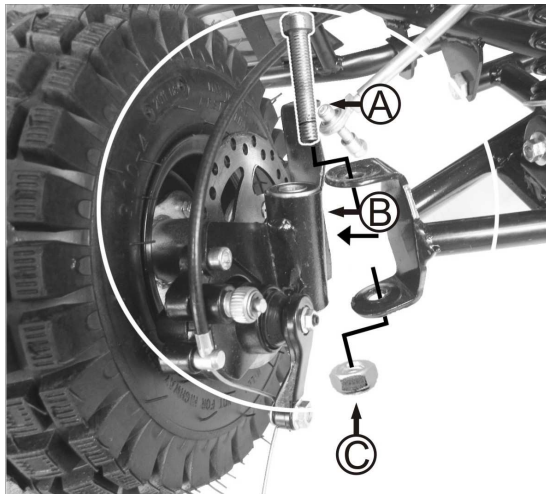

A: Bolt M10×90 2pcs

B: Wheel suspension left and right

C: Nut M10 2pcs

1. Put the front wheel suspension (B) into the front swing arm joint, align the bearing hole to the joint upper and bottom hole.
2. Mount the bolt (A) through the hole and twist the nut (C), tighten it securely with 17mm open end wrench and 8mm allen wrench.

ASSEMBLY TIE ROD

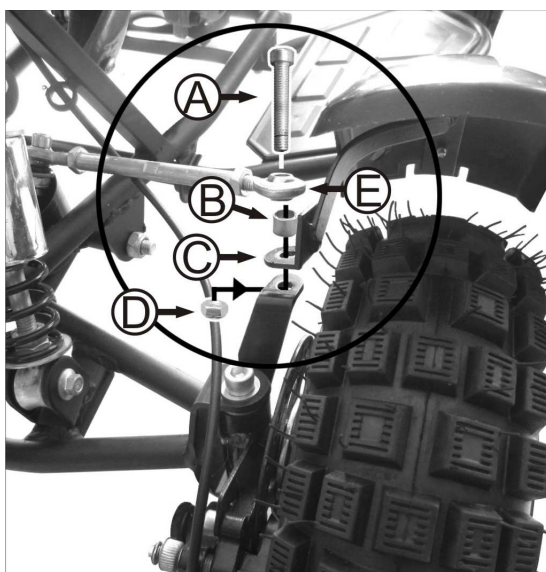

A :Bolt M8×40 2pcs

B: Bush $\Phi 10 \times 1.5 \times 10$ 2pcs

C: Bracket left and right 2pcs

D :Nut M8 2pcs

E. Tie rod left and right 2pcs

1. Align the hole of tie rod end ball (E), bush(B), bracket of mudguard(C) in sequence.
2. Mount the bolt(A) and tighten the nut (D) securely with 13mm open end wrench and 6mm allen wrench.

ASSEMBLY FRONT SHOCK

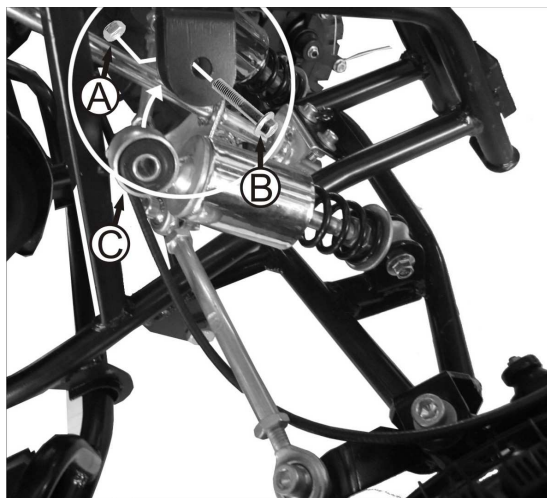

A: Nut M8 1pcs

B: Bolt M8×40 1pcs

C: Front shock

1. Uplift the frame to align the shock (3) mounting hole to the shackle joint hole.
2. Fix the bolt (2) through the shock mounting hole and shackle joint and tighten the nut (1) securely with 10mm and 13mm open end wrench.

ASSEMBLY BUMPER

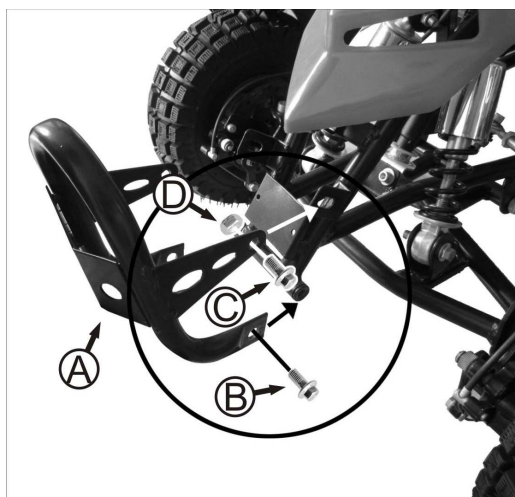

A: Bumper

B: Bolt M8×16 2pcs

C: Bolt M8×16 2pcs

D: Nut M8 4pcs

1. Align the bottom mounting hole of bumper (A) to the frame bottom joint and mount the bolt (B), NOT tighten the bolt to keep the bumper free move.
2. Turn upwards the bumper to align the upper mounting hole of bumper to the frame upper joint, then mount the bolt (C) and twist the nut (D).
3. Tighten the bolt (B) and nut(D) securely with 10mm and 13mm open end wrench

ASSEMBLY CHAIN COVER

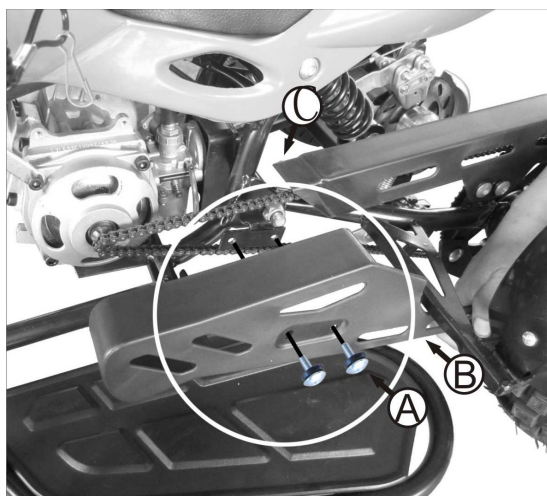

A: Bolt M6×16 2pcs

B: Front chain cover

C: Rear chain cover

1. Put the front part of chain cover (B) combine with the rear part of chain cover (C) and make sure the chain is well covered.
2. Install the 2pcs bolt (A) into the bracket and tighten it securely with allen wrench 5mm.

ASSEMBLY NUMBER BOARD

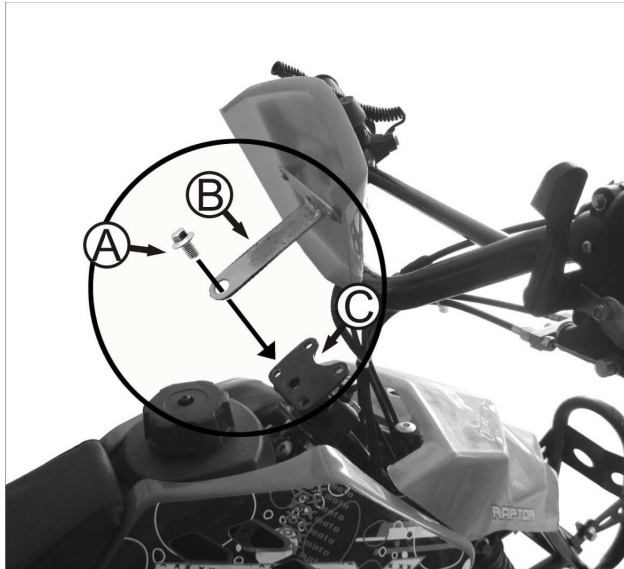

- A: Bolt M8×16 1pcs
- B: Number board bracket
- C: Steering rod plate

1. Place the bracket (B) on the steering rod plate (C) with the hole in alignment.
2. Install the bolt (A) and tighten it with 10mm open end wrench

ASSEMBLY HANDLEBAR

WARNING:

Failing to properly adjust and tighten the bolts that affix the handlebars can cause you to lose control and crash.

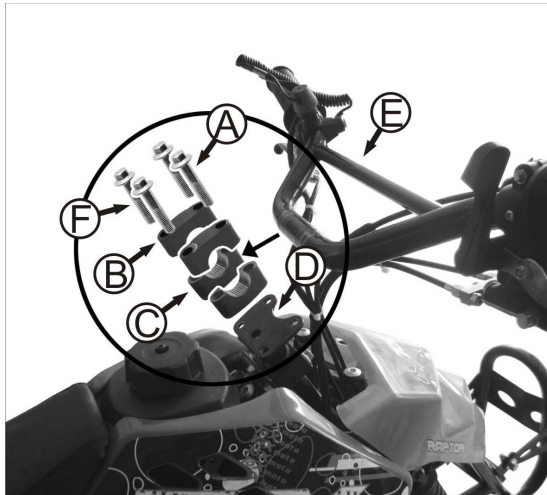

- A: Bolt M8×50 4pcs
- B: Upper Clamp
- C: Bottom Clamp
- D: Steering rod bracket
- E: Handle bar

1. Put the bottom clamp(C) on the steering rod plate(D) with the screw hole in alignment, and place the handlebar (E) in the bottom clamp, then cover the upper clamp (B) on the handlebar and install the 4pcs bolt (A).
2. Place the handlebar in the upright and vertical position, then tighten all the bolts securely with 10mm socket spanner.

● TECHNICAL SPECIFICATION SHEET

Engine type	single cylinder, 2 stroke, forced air cooling
Power output	2.0kw/7500rpm
Max torque	2.3 N.m/3600rpm
Displacement (ml)	44
Fuel	Petrol mixed with 4% 2-stroke engine oil
Compression Ratio	7.5 : 1
Transmission	automatic with centrifugal clutch
Start method	manual pull start
Optional / battery	Electric start / 12V 4AH
Max.speed (km/h)	32
Front suspension	double mechanical damper
Rear suspension	mono shock absorber
Tyre (standard 4 “)	front & rear 3.00-4 with 4.00 P.s.i operation pressure and 24 P.s.i Max. inflate
Tyre(optional 6 “)	front 4.10-6 with 7.00 P.s.i. operation pressure and 20 P.s.i. Max. inflate , rear 13.00 x 5-6 with 7.00 P.s.i. operation pressure and 20 P.s.i Max. inflate .
Brake system	front and rear disc brake with mechanical control
Fuel tank capacity	1L
Dry Weight (ATV with 4” / 6” wheel)	31KG / 38KG
Dimension (mm) (ATV with 4” / 6” wheel)	1065×590×740 / 1100 x 590×765
Seat height (mm) (ATV with 4” / 6” wheel)	550 / 570
Carton size (mm)	990×660×530

Inflating the Tires



NOTE:The 6” rear tires are inflated when shipped, but they invariably lose some pressure between the point of manufacturing and your purchase. Be sure to inflate the tires to the correct PSI before first time use.

Please read the specification sheet to get the information of tire pressure.

Using a bicycle-style tire pump to inflate the tire to the PSI indicated on the sidewall of the tire.

Note: The pressurized air supplies found at gasoline stations are designed to inflate high-volume automobile tires. If you decide to use such an air supply to inflate your tires, first make sure the pressure gauge is working, then use very short bursts to inflate to the correct PSI. If you inadvertently over-inflate the tire, release the excess pressure immediately.

Important information of use guider for tire

Note: Tire is the only contact surface between the vehicle to the road, the safety of various riding activity depends on the small surface of tire where contact with the road. Therefore, it is very important to keep the tire in good condition any time and use the correct size and standard tire to replace the used ones.

Guide:

Tire assembly and disassembly

It is strongly recommended that the tire assembly and disassembly should be done by an authorized technician with necessary skills.

Tire inflating pressure

It is very important to keep the tire in proper pressure and check the tire pressure before use. The inflating should be done while the tire is cold.

Tire maintenance

Tire tread depth should be checked regularly.(Shallower tread means less grip of tire). You must stop to use the vehicle if the tire is pierced, disassemble the tire and check it carefully. Tire maintenance should be done by an authorized technician. Tire should be replaced immediately when it is distorted or damaged.

Tire replacement

It is important to use the correct size and standard tire as per our specification (see details in technical specification sheet)

Don't use the used tire if you are not sure its previous service condition.

Tire aging

Tire aging is unavoidable even the tire is not ever used or just used a few times. Tire aging is mainly reflected in the cracked section on side of tire and tire tread, sometimes the tire is distorted as well. The used and aged tire should be checked and confirmed if it is ok to use again by an authorized technician

● Checks and maintenance before and after off-road use

In order to avoid problems connected to the operation of the vehicle, it is advisable to perform a number of checks and maintenance operations before and after use. Just a few minutes given to these procedures will save you time and money, and will make riding much safer.

Proceed as follows:

- Check pressure, general condition and thickness of tread.
- On cold days, warm up the engine by running it at idle speed for a few minutes before starting off.
- Wash the vehicle carefully after every off-road use.

● Fueling operations



Remove cap A counterclockwise.

The fuel tank will hold approximately 1.5 liter.

Only use green fuel mixture with 4% oil.

● Breaking in

During the first 25 hours of operation (running-in), the following precautions should be used;

- Avoid travel at high speeds
- Change speed often so that the parts will break in uniformly and in a shorter time
- Avoid turning the throttle more than 3/4 of the way.

Warning:

- Change the crankcase oil after 500km.
- Always use a mixture of green grade gas and a qualitatively good oil.
- After the first off-road use, check all of the nuts and bolts.

● Startup

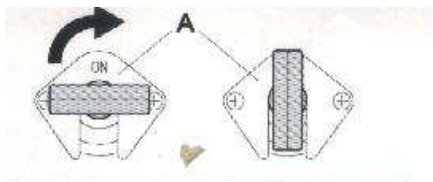

Manual hand pull

-Open fuel tank valve **A** **ON** = open

- Sharply pull on the starter as shown in the figure while slightly turning the throttle twist grip.

-Always close the fuel tank valve when the engine is off.

Note:

With the engine is cold, act on the starter by pushing down lever **B**, wait for a short and then reposition the lever to its former position.

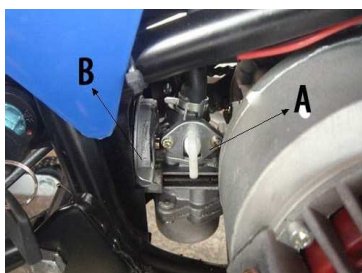

● AIR FILTER

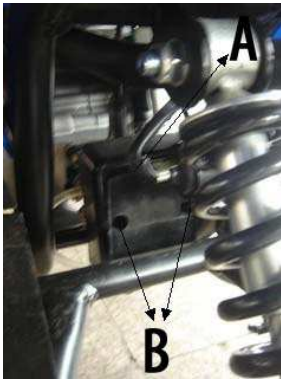

Air filter box **A** is fitted directly on the carburetor.

To remove the box, undo the two screws **B**.

The filter box contains filter element **C** and support **D**

Note:

If filter **C** is very dirty, wash it in shampoo and water and then reinsert it into its casing

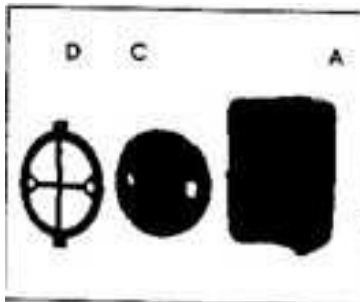

Clean the filter every time the vehicle is used cross country.

● SPARK PLUG

Keeping the spark plug in good condition will reduce fuel consumption and increase engine performance.

To perform the check, simply slide off the electrical connection tube and unscrew the spark plug. Examine the distance between the electrodes with a feeler. This distance should be from 0.5 to 0.6 mm. If it is not, it may be corrected by bending the earth electrode.

Check as well that there are no cracks in the insulation or corroded electrodes. If so, replace immediately.

When replacing the spark plug, screw it in by hand until it stops, then tighten with a wrench.

● BRAKES



Check

To check the wear of front and rear brake pads **A**, simply inspect the brakes calipers as shown in the figure.

The thickness of the lining on the ends of the four pads should never be less than 1mm.

Should the lining be thinner, immediately replace the brake pads.



We recommend having the brake pads replaced by an authorized dealer

● CHECKS AFTER CLEANING



After cleaning the motorcycle, it is good practice to:

- Take off the flywheel cover and remove any dirt and water.
- Apply the lubricant above articulation points **A** and **B** on the rear and front swing arm .
- Carefully clean and dry the chain-gear-position assembly and then apply grease thoroughly in order keep these parts in good condition as long as possible.
- Dry well any metal parts subject to corrosion, oxidation, etc.

● ADJUSTMENTS

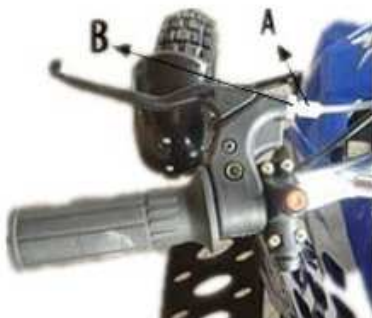

The front and rear brakes is a mechanically operated disc brake, which require periodic adjustment. As shown in the figure, there should be 5-6 mm play, to adjust the play, follow these steps:

- Check the play in driving position.
- If the clearance is excessive, use adjuster **A** on the obtain the desired position.
- Tighten locknut **B**.



Note:

The front and rear brake calipers are equipped with an adjuster **C** that allows the braking action to be adjusted by moving the brake lever towards or away from the disc.

Note:

To adjust the tension of the brakes cables, loosen self-locking nut **C**, retension the cable and then tighten fastener **C** again.

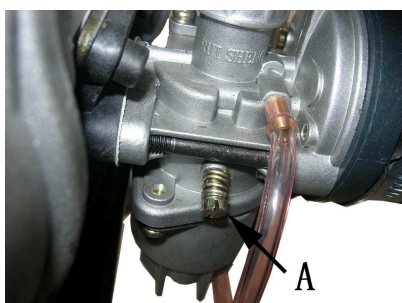

● ADJUSTMENT OF IDLING SPEED

In order to perform this operation correctly, we advise you to do it when the engine is hot, connecting an electric revolution counter to the spark plug wire. Then use a screwdriver on register screw **A** to calibrate the minimum.



● **CAUTION**

Always release the remaining fuel from the carburetor after use every time following the below steps

1. use a screwdriver to screw out the drain plug at the bottom of carburetor.
2. release the remaining fuel.
3. use a screwdriver to tighten the drain plug securely.

TROUBLESHOOTING

PROBLEM	CAUSE	REMEDY
The engine doesn't start	-Fuel system(tubes, fuel tank, valve) is blocked	Clean the system
	-No current arriving at spark plug	Clean or replace spark plug. If the problem persists, consult one of our Authorized Dealers
	-Engine is flooded	With gas completely open, continue trying to start engine for a few Moments. If engine still doesn't start, remove the spark plug and dry it off.
Engine misfires	-Spark plug has irregular electrode distance	Restore correct distance
	-Spark pug is dirty	Clean or replace
Engine overheats and loses power	-Silencer partially obstructed	Contact an authorized dealer
	-Exhaust clearance partially obstructed	Contact an authorized dealer
	-Mix too lean	Jet may be partially obstructed
	-Delayed ignition	Contact an authorized dealer
Weak brake	-Worn Brake pads	Contact an authorized dealer

● **CIRCUIT DIAGRAM for electric start model**

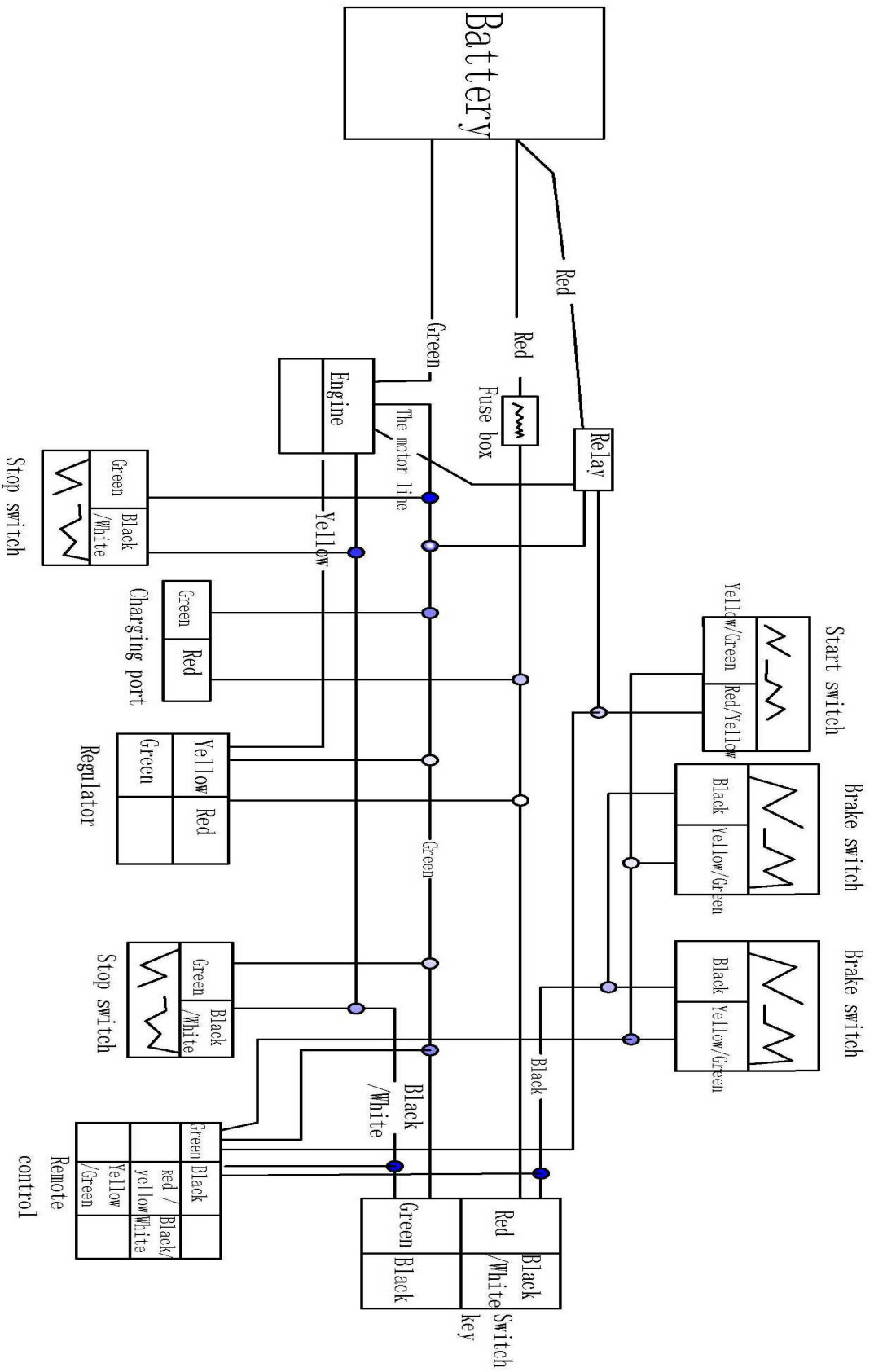

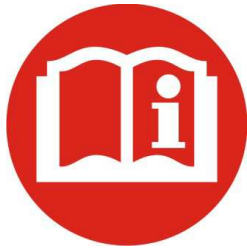

Please read the owner's manual before riding.



Never operate this vehicle if you are under age 12.



Never use the vehicle on public road. OFF ROAD use only.



Never ride with a passenger



Always use an approved helmet and protective gear



NEVER use with drugs or alcohol

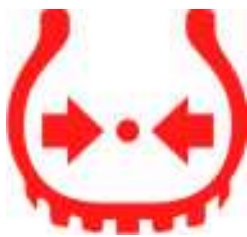

Cold tire pressure.