



COUPLINGS & UNIVERSAL JOINTS
BY TIMKEN

Standard

Single-Ended Spacer

Double-Ended Spacer

Splined Hub

QUICK FLEX[®] Couplings

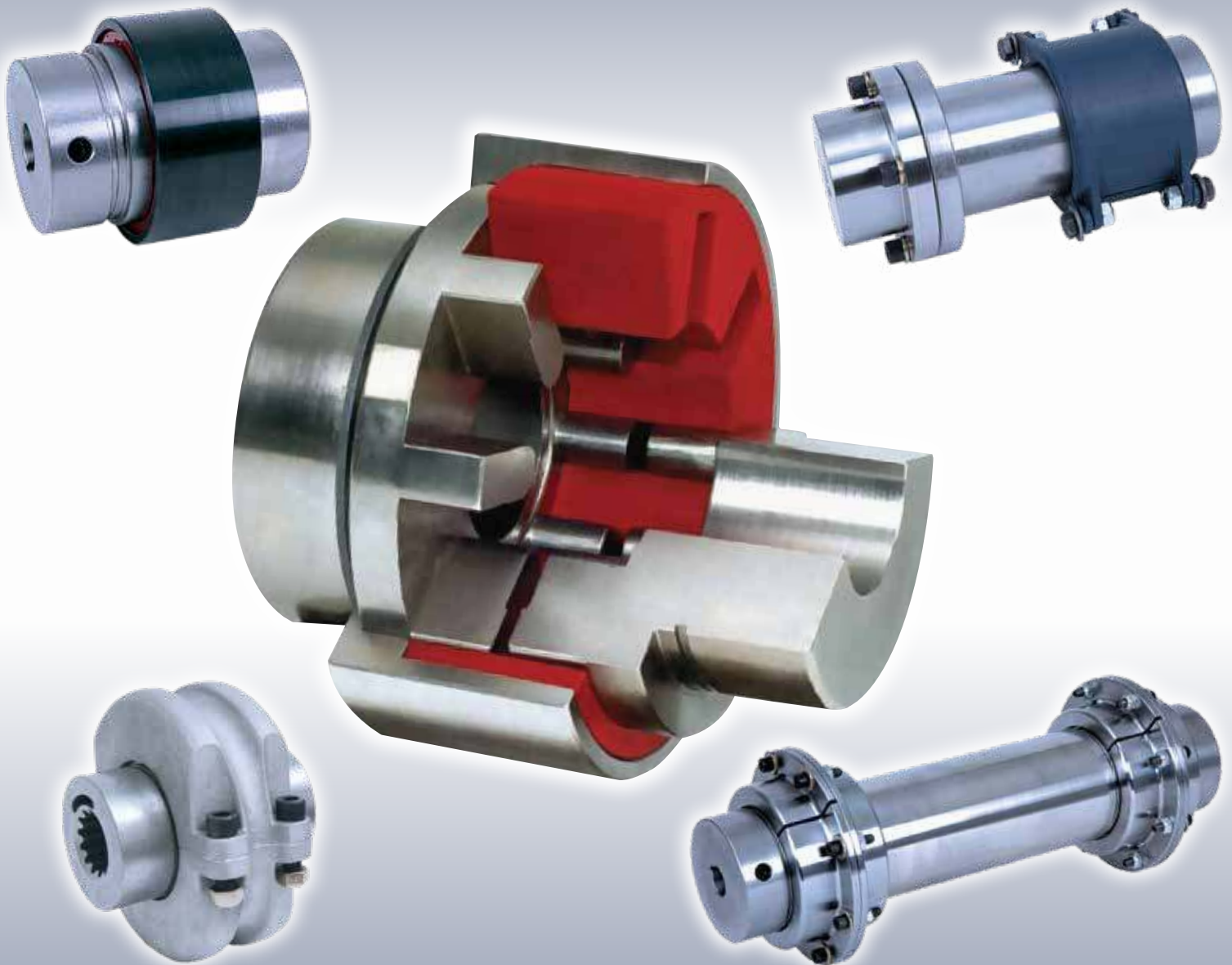

Better Performance. Less Maintenance.



Over a Century of Invention...

With its longstanding reputation for innovation, service and quality-driven work performance, Lovejoy has developed the expertise to engineer products that address the complex needs of its customers' applications. No matter what the application, Lovejoy has the selection, service and solution for it.

Thomas Lovejoy established this company in 1900 as a manufacturer of tooling and machinery for the railroad and steel industries. The company's pioneer work over the next century in advancing manufacturing technologies has included the introduction of the industry standard Jaw-style coupling in 1927, as a first, incorporated rubber in-compression power transmission concept. Through the years, Lovejoy continuously added to the power transmission elastomeric and metal coupling offering with the manufacturing of universal joints, variable speed pulley products, Uniflex, Torsional, S-Flex, Deltaflex, Gear, Grid, Disc, Curved Jaw, Jaw In-Shear and Motion Control as well as the newest addition of the QUICK FLEX coupling. With the same trust earned in the Power Transmission Industry, Lovejoy has grown to serve similar industries. For over sixty years, Lovejoy has been offering to the hydraulics industry a full line of couplings, reservoirs and accessories, oil coolers, and pump / motor mounts. Lovejoy also moved into additional industries more than thirty five years ago using elastomeric elements, which function as either a vibration control, spring action, tensioning device or bearing alternative.

Global in Reach, Service and Support...

Lovejoy has grown to become an international market leader by expanding its reach into the global marketplace. Lovejoy products are available through a network of distributors, which are located in every major market throughout North America and in over 80 other countries. Lovejoy ships more than 100,000 components each week. These components are exported globally – to Africa, Asia, Australia, Eastern and Western Europe, Central and South America, the Caribbean and the Middle East, as well as throughout North America. World headquarters are in Downers Grove, Illinois, USA with more than 400 employees worldwide, as well as business operations located in the United States, Canada and Germany. In the United States alone, there are more than 30 sales offices and regional warehouses.



Lovejoy World Headquarters in Downers Grove, Illinois USA



Lovejoy continues to innovate and improve their products to optimally serve the many industries it supports.

Our Commitment to Customers...

Lovejoy has a worldwide reputation for building and sustaining long-term customer satisfaction through quality of service, products and design reliability. Certified to ISO 9001 International Standards for Quality Management, Lovejoy manufactures all of its products to the exacting requirements of international standards such as AGMA, ANSI, SAE, DIN, JIS and Imperial. Lovejoy is also an accepted supplier of products that match military specifications.

Table of Contents

Technology Overview

See pages 4-5

Engineering

See pages 6-20

QUICK FLEX Standard Bore Sizes	6
QUICK FLEX Bore Tolerances and Keyway Sizes	8
Torque Calculations	9
Torque Ratings and Misalignment Tolerances.....	10
QUICK FLEX Coupling Service Factors for Applications	15
QUICK FLEX Coupling Insert Chemical Compatibility.....	18
Installation Guides.....	20
Storage of Components	54

QUICK FLEX Couplings

See pages 32-53

Nomenclature	32
Inserts and Covers	34
Standard Couplings	37
Single-Ended Spacer Couplings.....	42
Double-Ended Spacer Couplings	45
Bushing-Style Interchange Couplings.....	49
Splined-Hub Couplings.....	52
Mill-Motor Couplings	53

DISCLAIMER

This catalog is provided solely to give you analysis tools and data to assist you in your product selection. Product performance is affected by many factors beyond the control of Lovejoy. Therefore, you must validate the suitability and feasibility of all product selections for your applications.

Lovejoy products are sold subject to Lovejoy terms and conditions of sale, which include our limited warranty and remedy. You can find these at <http://www.timken.com/en-us/purchase/Pages/TermsandConditionsofSale.aspx>.

Please consult with your Lovejoy engineer for more information and assistance.

Every reasonable effort has been made to ensure the accuracy of the information in this writing, but no liability is accepted for errors, omissions or for any other reason.

This publication contains dimensions, tolerances and load ratings, as well as engineering sections describing fitting practices for shafts and housings, internal clearances, materials and other bearing features. It provides valuable assistance in the initial consideration of the type and characteristics of the bearings that may best suit your particular needs.

ISO and ANSI/ABMA, as used in this publication, refer to the International Organization for Standardization and the American National Standards Institute/American Bearing Manufacturers Association.

Updates are made periodically to this catalog. Visit www.lovejoy-inc.com for the most recent version of the QUICK FLEX® Coupling Catalog.

WARNING

Failure to observe the following warnings could create a risk of death or serious injury.

Proper maintenance and handling practices are critical. Failure to follow selection recommendations and installation instructions and to maintain proper lubrication can result in equipment failure.

When your equipment operates in harsh environments, you need products you can count on, like QUICK FLEX® elastomeric couplings. They are durable enough to face extreme challenges, yet need minimal maintenance. They are also easy to install and require no lubrication. With a lifespan that may last as long as your equipment, overall cost of ownership remains low.

Pioneering Design

QUICK FLEX couplings' innovative design features two steel hubs, a polyurethane insert and a cover.

Our styles include:

- Standard couplings.
- Single-ended spacer couplings.
- Double-ended spacer couplings.

Whatever your application, you'll find a coupling to suit your needs:

- Twelve families with bore ranges from 10 mm (0.37 in) to 285 mm (11.25 in).
- Continuous torque handling from 0.043 kNm (377 in-lbs) to 188.8 kNm (1,670,826 in-lbs).
- Able to handle temperatures from -51° C to 176° C (-60° F to 350° F).

Product Advantages

More Uptime

Your hubs and shafts may remain intact when you use QUICK FLEX couplings. Our design helps eliminate mechanical interference between coupling hubs that can damage your equipment. As needed, you can replace the urethane insert quickly and easily without removing the hubs.

Durability

There's no metal-to-metal contact between opposing hubs with QUICK FLEX couplings, so you'll save money not replacing hubs or other metal components since they do not wear. For harsh environments, including wash-downs for food processing, we offer a stainless-steel version of each coupling.

Reduced Inventory

The versatility of the QUICK FLEX design promotes component standardization across your plant, reducing the need to stock multiple coupling styles and configurations.

Product Features

- Solid and split covers handle high speeds and torque.
- Design dampens torsional vibration and shock.
- Accepts shaft misalignment up to 2 degrees.
- Eliminates the need to move or disassemble the driving or driven equipment to replace the coupling insert.
- Versatility of design makes it a great tool for plant standardization.
- Accepts shaft sizes from 10 mm (0.37 in) to 285 mm (11.25 in).
- Peak handling torque from 0.085 kNm (754 in-lbs) to 377.5 kNm (3,341,562 in-lbs).
- Standard and double-ended spacer couplings available for shaft separations of 25.4 mm to 3,048 mm (1 in to 120 in), for increased application acceptance.
- Four bore options available to meet customers' needs; 1) Bored, keyed and set screws style – clearance and interference fit; 2) Bushing style; 3) Splined style; and 4) Mill-motor style.
- Stainless-steel versions available for corrosive environments.
- Four insert choices for varying torque needs and temperature ranges, up to 177° C (350° F).
- Replaces many common gear, grid and elastomeric couplings used in high- and low-torque applications to reduce plant complexity.
- Inherently balanced from precision machining for high-speed applications.
- Split cover options help resist axial separating force under high torque.



QUICK FLEX Comparison	QUICK FLEX Coupling	Jaw Coupling	Jaw In-Shear Coupling	Grid Coupling	Gear Coupling	Chain Coupling	Tire Coupling	Disc Coupling
Radially removable insert/element	•		•	•	N/A	N/A	•	•
High torque capability	•			•	•			•
High-speed capacity	•	•			•			•
Torque transmission in shear	•		•	•	N/A	N/A	•	•
Non-Lubricated	•	•	•				•	•
No hub teeth wear	•	•	•				N/A	•
Shock load capabilities	•	•	•	•			•	
Angular misalignment	Medium	Low	Medium	Low	High	Low	Medium	High

Product Offering

QUICK FLEX couplings stand up to harsh environments and operate efficiently in applications including:

- Motor to gearbox (low torque/high speed).
- Gearbox to driven equipment (high torque/low speed).
- Motors to pumps.
- Any drive shaft to a driven shaft.

Quality Solutions

As a leading premium bearing and coupling manufacturer, we understand the critical quality link between materials and product performance.

We also strictly adhere to the Quality Management System in every plant worldwide, so each product meets the same high quality standards – no matter where in the world it is manufactured.

Dependable Service

Every QUICK FLEX elastomeric coupling is backed by the service of our industry-leading experts, who are ready to assist you with product design, application knowledge and engineering support – anything you need to help improve uptime and maximize equipment performance.

Updates are made periodically to this catalog. Visit www.lovejoy-inc.com for the most recent version of the QUICK FLEX Coupling Catalog.



Standard Couplings

Shown with high-speed cover

Single-Ended Spacer Couplings

Shown with low-speed split cover

Double-Ended Spacer Couplings

Shown with high-speed split cover

Splined Hub Couplings

Shown with high-performance split cover

QUICK FLEX Standard Bore Sizes - Inch

The following tables list, by bore size in inch dimensions, couplings that are commonly stocked.

Standard Bore Sizes Inch – Clearance Fit

Coupling Series	Pilot Bore	$\frac{1}{2}$	$\frac{5}{8}$	$\frac{3}{4}$	$\frac{7}{8}$	1	$1\frac{1}{8}$	$1\frac{3}{16}$	$1\frac{1}{4}$	$1\frac{3}{8}$	$1\frac{7}{16}$	$1\frac{1}{2}$	$1\frac{5}{8}$	$1\frac{3}{4}$
		in	in	in	in	in	in	in	in	in	in	in	in	in
QF5	x	x	x	x	x	x	x	x	x					
QF15	x		x	x	x	x	x	x	x	x	x	x	x	
QF25	x			x	x	x	x	x	x	x	x	x	x	x
QF50	x				x	x	x	x	x	x	x	x	x	x
QF100	x											x	x	x
QF175	x													
QF250	x													
QF500	x													
QF1000	x													
QF1890	x													
QF3150	x													
QF10260	x													

Standard Bore Sizes Inch – Clearance Fit , Continued

Coupling Series	Pilot Bore	$1\frac{7}{8}$	$1\frac{15}{16}$	2	$2\frac{1}{8}$	$2\frac{3}{16}$	$2\frac{1}{4}$	$2\frac{3}{8}$	$2\frac{7}{16}$	$2\frac{1}{2}$	$2\frac{5}{8}$	$2\frac{3}{4}$	$2\frac{7}{8}$	$2\frac{15}{16}$	3
		in	in	in	in	in	in	in	in	in	in	in	in	in	in
QF5	x														
QF15	x														
QF25	x	x	x	x	x										
QF50	x	x	x	x	x	x	x	x							
QF100	x	x	x	x	x	x	x	x	x	x	x	x	x	x	x
QF175	x														
QF250	x														
QF500	x														
QF1000	x														
QF1890	x														
QF3150	x														
QF10260	x														

Note: ■ Inch bore and keyway tolerances conform to ANSI/AGMA 9002.

QUICK FLEX Standard Bore Sizes - Metric

The following tables list, by bore size in metric dimensions, couplings that are commonly stocked.

Standard Bore Sizes Metric – Clearance Fit

Coupling Series	Pilot Bore	11	12	14	15	16	18	19	20	22	24	25	28	30
		mm	mm	mm	mm	mm	mm	mm	mm	mm	mm	mm	mm	mm
QF5	x	x	x	x	x	x	x	x	x	x	x	x		
QF15	x							x	x	x	x	x	x	x
QF25	x							x	x	x	x	x	x	x
QF50	x													x
QF100	x											x	x	x
QF175	x													
QF250	x													
QF500	x													
QF1000	x													
QF1890	x													
QF3150	x													
QF10260	x													

Standard Bore Sizes Metric – Clearance Fit , Continued

Coupling Series	Pilot Bore	32	34	35	38	40	42	45	48	50	55	60	65	70	75
		mm	mm	mm	mm	mm	mm	mm	mm	mm	mm	mm	mm	mm	mm
QF5	x														
QF15	x	x	x	x	x	x									
QF25	x	x	x	x	x	x	x	x	x	x					
QF50	x	x	x	x	x	x	x	x	x	x	x	x			
QF100	x									x	x	x	x	x	x
QF175	x														
QF250	x														
QF500	x														
QF1000	x														
QF1890	x														
QF3150	x														
QF10260	x														

Note: ■ Standard metric clearance bore is H7 Tolerance per ISO 266. Keyway conforms to ANSI/AGMA 9112 normal keyway width tolerance.

QUICK FLEX Bore Tolerances and Keyway Sizes

Table 3. Bore Tolerances and Keyway Sizes (Imperial)

Nominal Shaft Diameter Range		Nominal Key Size		Nominal Keyway Size		Bore Tolerance				Set Screw
Over	Up to and Including	Width	Depth	Width	Depth	Clearance Fit		Interference Fit		
in	in	in	in	in	in	in	in	in	in	
5/16	7/16	3/32	3/32	3/32	3/64	+0.010	0	-0.0005	-0.010	2 @ 120°
7/16	9/16	1/8	1/8	1/8	1/16	+0.010	0	-0.0005	-0.010	
9/16	7/8	3/16	3/16	3/16	3/32	+0.010	0	-0.0005	-0.010	
7/8	1-1/4	1/4	1/4	1/4	1/8	+0.010	0	-0.0005	-0.010	
1-1/4	1-3/8	5/16	5/16	5/16	5/32	+0.010	0	-0.0005	-0.010	
1-3/8	1-1/2	3/8	3/8	3/8	3/16	+0.010	0	-0.0005	-0.010	
1-1/2	1-3/4	3/8	3/8	3/8	3/16	+0.010	0	-0.010	-0.020	
1-3/4	2	1/2	1/2	1/2	1/4	+0.010	0	-0.010	-0.020	
2	2-1/4	1/2	1/2	1/2	1/4	+0.015	0	-0.010	-0.020	
2-1/4	2-3/4	5/8	5/8	5/8	5/16	+0.015	0	-0.010	-0.020	
2-3/4	3	3/4	3/4	3/4	3/8	+0.015	0	-0.010	-0.020	
3	3-1/4	3/4	3/4	3/4	3/8	+0.015	0	-0.015	-0.030	
3-1/4	3-3/4	7/8	7/8	7/8	7/16	+0.015	0	-0.015	-0.030	
3-3/4	4	1	1	1	1/2	+0.015	0	-0.015	-0.030	
4	4-1/2	1	1	1	1/2	+0.015	0	-0.020	-0.035	
4-1/2	5	1-1/4	1-1/4	1-1/4	5/8	+0.015	0	-0.020	-0.035	
5	5-1/2	1-1/4	1-1/4	1-1/4	5/8	+0.015	0	-0.025	-0.040	
5-1/2	6	1-1/2	1-1/2	1-1/2	3/4	+0.015	0	-0.025	-0.040	
6	6-1/2	1-1/2	1-1/2	1-1/2	3/4	+0.015	0	-0.025	-0.040	
6-1/2	7	1-3/4	1-1/2	1-3/4	3/4			-0.025	-0.040	
7	7-1/2	1-3/4	1-1/2	1-3/4	3/4			-0.030	-0.050	
7-1/2	8	2	1-1/2	2	3/4			-0.030	-0.050	
8	9	2	1-1/2	2	3/4			-0.035	-0.055	
9	10	2-1/2	1-3/4	2-1/2	7/8			-0.040	-0.060	
10	11	2-1/2	1-3/4	2-1/2	7/8			-0.045	-0.065	
11	12	3	2	3	1			-0.050	-0.070	

Note: ■ Inch bore and keyway tolerances conform to ANSI/AGMA 9002.

Table 4. Bore Tolerances and Keyway Sizes (Metric)

Nominal Shaft Diameter Range		Nominal Key Size		Nominal Keyway Size		Bore Tolerance				Set Screw Size mm
Over	Up to and Including	Width	Depth	Width	Depth	Clearance Fit (H7)		Interference Fit (P7)		
mm	mm	mm	mm	mm	mm	mm	mm	mm	mm	
6	8	2	2	2	1	+0.015	-0.000	-0.009	-0.024	2 @ 120°
8	10	3	3	3	1.4	+0.015	-0.000	-0.009	-0.024	
10	12	4	4	4	1.8	+0.018	-0.000	-0.011	-0.029	
12	17	5	5	5	2.3	+0.018	-0.000	-0.011	-0.029	
17	18	6	6	6	2.8	+0.018	-0.000	-0.011	-0.029	
18	22	6	6	6	2.8	+0.021	-0.000	-0.014	-0.035	
22	30	8	7	8	3.3	+0.021	-0.000	-0.014	-0.035	
30	38	10	8	10	3.3	+0.025	-0.000	-0.017	-0.042	
38	44	12	8	12	3.3	+0.025	-0.000	-0.017	-0.042	
44	50	14	9	14	3.8	+0.025	-0.000	-0.017	-0.042	
50	58	16	10	16	4.3	+0.030	-0.000	-0.021	-0.051	
58	65	18	11	18	4.4	+0.030	-0.000	-0.021	-0.051	
65	75	20	12	20	4.9	+0.030	-0.000	-0.021	-0.051	
75	80	22	14	22	5.4	+0.030	-0.000	-0.021	-0.051	
80	85	22	14	22	5.4	+0.035	-0.000	-0.024	-0.059	
85	95	25	14	25	5.4	+0.035	-0.000	-0.024	-0.059	
95	110	28	16	28	6.4	+0.035	-0.000	-0.024	-0.059	
110	120	32	18	32	7.4	+0.035	-0.000	-0.024	-0.059	
120	130	32	18	32	7.4	+0.040	-0.000	-0.028	-0.068	
130	150	36	20	36	8.4	+0.040	-0.000	-0.028	-0.068	
150	170	40	22	40	9.4	+0.040	-0.000	-0.028	-0.068	
170	180	45	25	45	10.4	+0.040	-0.000	-0.028	-0.068	
180	200	45	25	45	10.4	+0.046	-0.000	-0.033	-0.079	

Note: ■ Metric bore tolerances conform to ISO 286-2 H7 for clearance fit and P7 for interference fit. Metric keyway tolerances conform to ANSI/AGMA 9112 Normal keyway width tolerance.

Torque Calculation – Selecting QUICK FLEX Couplings

QUICK FLEX Coupling Selection Using Inch-Pound Torque Ratings

To select the correct QUICK FLEX coupling for your application, use the formulas below, the torque ratings on pages 11-13 and the maximum bore sizes and speed ratings on pages 35-41. If you need further assistance, please contact your Lovejoy Application engineer or visit www.lovejoy-inc.com.

Design Torque (in-lbs) =
Actual torque (in-lbs) x service factor
(See pages 15-17.)

$$\text{Actual Torque (in-lbs)} = \frac{63025 \times \text{HP}}{\text{RPM}}$$

where:

HP = Drive horsepower

RPM = Drive shaft revolutions per minute

QUICK FLEX Coupling Selection Using Newton Meter Torque Ratings

To select the correct QUICK FLEX coupling for your application, use the formulas below, the torque ratings on page 11-13 and maximum bore sizes and speed ratings on pages 35-41 to determine which QUICK FLEX coupling meets the design torque, maximum shaft size and speed rating of your application. If you need further assistance, please contact your Lovejoy Application engineer or visit www.lovejoy-inc.com.

Design Torque (Nm) =
Actual torque (Nm) x service factor
(See pages 15-17.)

$$\text{Actual Torque (Nm)} = \frac{9550 \times \text{kW}}{\text{RPM}}$$

where:

kW = Drive kilowatts

RPM = Drive shaft revolutions per minute

Helpful Conversion Formulas

(Nm ↔ in-lbs) → 1 Nm = 8.85 in-lbs

(kW ↔ HP) → 1 kW = 1.341 HP

Torque Ratings and Misalignment Tolerances

Table 5. QUICK FLEX Coupling Torque Ratings with High-Speed Cover (Imperial)

Coupling Series	Insert Part No.	Insert Color	Continuous Torque in-lbs	HP Ratings @ Various RPM (Service Factor = 1)									
				50	100	300	600	900	1200	1750	2400	3600	5000
QF5	QF5INSERT	Red	377	0.3	0.6	1.8	3.6	5.4	7.2	10.5	14.4	21.5	29.9
	QF5HINSERT	White	819	0.6	1.3	3.9	7.8	11.7	15.6	22.7	31.2	46.8	65.0
	QF5BINSERT	Blue	819	0.6	1.3	3.9	7.8	11.7	15.6	22.7	31.2	46.8	65.0
QF15	QF15INSERT	Red	1059	0.8	1.7	5.0	10.1	15.1	20.2	29.4	40.3	60.5	84.0
	QF15HINSERT	White	2075	1.6	3.3	9.9	19.8	29.6	39.5	57.6	79.0	118.5	164.6
	QF15BINSERT	Blue	2075	1.6	3.3	9.9	19.8	29.6	39.5	57.6	79.0	118.5	164.6
QF25	QF25INSERT	Red	3426	2.7	5.4	16.3	32.6	48.9	65.2	95.1	130.5	195.7	271.8
	QF25HINSERT	White	6461	5.1	10.3	30.8	61.5	92.3	123.0	179.4	246.0	369.1	512.6
	QF25BINSERT	Blue	6461	5.1	10.3	30.8	61.5	92.3	123.0	179.4	246.0	369.1	512.6
QF50	QF50INSERT	Red	7066	5.6	11.2	33.6	67.3	100.9	134.5	196.2	269.1	403.6	560.6
	QF50HINSERT	White	14002	11.1	22.2	66.6	133.3	199.9	266.6	388.8	533.2	799.8	1110.8
	QF50BINSERT	Blue	14002	11.1	22.2	66.6	133.3	199.9	266.6	388.8	533.2	799.8	1110.8
QF100	QF100INSERT	Red	14178	11.2	22.5	67.5	135.0	202.5	270.0	393.7	539.9	809.9	1124.8
	QF100HINSERT	White	28115	22.3	44.6	133.8	267.7	401.5	535.3	780.7	1070.6	1605.9	2230.5
	QF100BINSERT	Blue	28115	22.3	44.6	133.8	267.7	401.5	535.3	780.7	1070.6	1605.9	2230.5
QF175	QF175INSERT	Red	24602	19.5	39.0	117.1	234.2	351.3	468.4	683.1	936.8	1405.3	1951.8
	QF175HINSERT	White	47123	37.4	74.8	224.3	448.6	672.9	897.2	1308.5	1794.4	2691.7	3738.4
	QF175BINSERT	Blue	47123	37.4	74.8	224.3	448.6	672.9	897.2	1308.5	1794.4	2691.7	3738.4
QF250	QF250INSERT	Red	31091	24.7	49.3	148.0	296.0	444.0	592.0	863.3	1183.9	1775.9	2466.6
	QF250HINSERT	White	61726	49.0	97.9	293.8	587.6	881.5	1175.3	1713.9	2350.5	3525.8	4896.9
	QF250BINSERT	Blue	61726	49.0	97.9	293.8	587.6	881.5	1175.3	1713.9	2350.5	3525.8	4896.9
QF500	QF500INSERT	Red	60091	47.7	95.3	286.0	572.1	858.1	1144.1	1668.5	2288.3	3432.4	4767.2
	QF500HINSERT	White	115497	91.6	183.3	549.8	1099.5	1649.3	2199.1	3207.0	4398.1	6597.2	9162.8
	QF500BINSERT	Blue	115497	91.6	183.3	549.8	1099.5	1649.3	2199.1	3207.0	4398.1	6597.2	9162.8
QF1000	QF1000INSERT	Red	84966	67.4	134.8	404.4	808.9	1213.3	1617.8	2359.2	3235.5	-	-
	QF1000HINSERT	White	162997	129.3	258.6	775.9	1551.7	2327.6	3103.5	4525.9	6206.9	-	-
	QF1000BINSERT	Blue	162997	129.3	258.6	775.9	1551.7	2327.6	3103.5	4525.9	6206.9	-	-
QF1890	QF1890INSERT	Red	95061	75.4	150.8	452.5	905.0	1357.5	1810.0	2639.5	3620.0	-	-
	QF1890HINSERT	White	180639	143.3	286.6	859.8	1719.7	2579.5	3439.4	5015.8	6878.8	-	-
	QF1890BINSERT	Blue	180639	143.3	286.6	859.8	1719.7	2579.5	3439.4	5015.8	6878.8	-	-
QF3150	QF3150INSERT	Red	105135	83.4	166.8	500.4	1000.9	1501.3	2001.8	2919.3	-	-	-
	QF3150HINSERT	White	198252	157.3	314.6	943.7	1887.4	2831.0	3774.7	5504.8	-	-	-
	QF3150BINSERT	Blue	198252	157.3	314.6	943.7	1887.4	2831.0	3774.7	5504.8	-	-	-
QF10260	QF10260INSERT	Red	210173	166.7	333.5	1000.4	2000.9	3001.3	4001.7	-	-	-	-
	QF10260HINSERT	White	395913	314.1	628.2	1884.6	3769.1	5653.7	7538.2	-	-	-	-
	QF10260BINSERT	Blue	395913	314.1	628.2	1884.6	3769.1	5653.7	7538.2	-	-	-	-

Note: ■ QUICK FLEX flexible couplings can sustain momentary peak torque loads up to 200 percent of their continuous torque rating.

Torque Ratings and Misalignment Tolerances

Table 6. QUICK FLEX Coupling Torque Ratings with High-Speed Cover (Metric)

Coupling Series	Insert Part No.	Insert Color	Continuous Torque Nm	kW Ratings @ Various RPM (Service Factor = 1)									
				50	100	300	600	900	1200	1750	2400	3600	5000
QF5	QF5INSERT	Red	43	0.2	0.4	1.3	2.7	4.0	5.4	7.8	10.7	16.1	22.3
	QF5HINSERT	White	93	0.5	1.0	2.9	5.8	8.7	11.6	17.0	23.3	34.9	48.5
	QF5BINSERT	Blue	93	0.5	1.0	2.9	5.8	8.7	11.6	17.0	23.3	34.9	48.5
QF15	QF15INSERT	Red	120	0.6	1.3	3.8	7.5	11.3	15.0	21.9	30.1	45.1	62.6
	QF15HINSERT	White	234	1.2	2.5	7.4	14.7	22.1	29.5	43.0	58.9	88.4	122.8
	QF15BINSERT	Blue	234	1.2	2.5	7.4	14.7	22.1	29.5	43.0	58.9	88.4	122.8
QF25	QF25INSERT	Red	387	2.0	4.1	12.2	24.3	36.5	48.6	70.9	97.3	145.9	202.7
	QF25HINSERT	White	730	3.8	7.6	22.9	45.9	68.8	91.7	133.8	183.5	275.2	382.2
	QF25BINSERT	Blue	730	3.8	7.6	22.9	45.9	68.8	91.7	133.8	183.5	275.2	382.2
QF50	QF50INSERT	Red	798	4.2	8.4	25.1	50.2	75.2	100.3	146.3	200.6	301.0	418.0
	QF50HINSERT	White	1582	8.3	16.6	49.7	99.4	149.1	198.8	289.9	397.6	596.4	828.3
	QF50BINSERT	Blue	1582	8.3	16.6	49.7	99.4	149.1	198.8	289.9	397.6	596.4	828.3
QF100	QF100INSERT	Red	1602	8.4	16.8	50.3	100.7	151.0	201.3	293.6	402.6	603.9	838.8
	QF100HINSERT	White	3177	16.6	33.3	99.8	199.6	299.4	399.2	582.1	798.4	1197.6	1663.3
	QF100BINSERT	Blue	3177	16.6	33.3	99.8	199.6	299.4	399.2	582.1	798.4	1197.6	1663.3
QF175	QF175INSERT	Red	2780	14.6	29.1	87.3	174.7	262.0	349.3	509.4	698.6	1047.9	1455.4
	QF175HINSERT	White	5325	27.9	55.8	167.3	334.5	501.8	669.1	975.7	1338.1	2007.2	2787.8
	QF175BINSERT	Blue	5325	27.9	55.8	167.3	334.5	501.8	669.1	975.7	1338.1	2007.2	2787.8
QF250	QF250INSERT	Red	3513	18.4	36.8	110.4	220.7	331.1	441.4	643.8	882.9	1324.3	1839.3
	QF250HINSERT	White	6975	36.5	73.0	219.1	438.2	657.3	876.4	1278.1	1752.8	2629.2	3651.7
	QF250BINSERT	Blue	6975	36.5	73.0	219.1	438.2	657.3	876.4	1278.1	1752.8	2629.2	3651.7
QF500	QF500INSERT	Red	6790	35.5	71.1	213.3	426.6	639.9	853.2	1244.2	1706.4	2559.6	3554.9
	QF500HINSERT	White	13051	68.3	136.7	410.0	819.9	1229.9	1639.9	2391.5	3279.7	4919.6	6832.7
	QF500BINSERT	Blue	13051	68.3	136.7	410.0	819.9	1229.9	1639.9	2391.5	3279.7	4919.6	6832.7
QF1000	QF1000INSERT	Red	9601	50.3	100.5	301.6	603.2	904.8	1206.4	1759.3	2412.7	-	-
	QF1000HINSERT	White	18418	96.4	192.9	578.6	1157.1	1735.7	2314.3	3375.0	4628.5	-	-
	QF1000BINSERT	Blue	18418	96.4	192.9	578.6	1157.1	1735.7	2314.3	3375.0	4628.5	-	-
QF1890	QF1890INSERT	Red	10740	56.2	112.5	337.4	674.8	1012.2	1349.6	1968.2	2699.2	-	-
	QF1890HINSERT	White	20409	106.9	213.7	641.1	1282.3	1923.4	2564.5	3740.0	5129.1	-	-
	QF1890BINSERT	Blue	20409	106.9	213.7	641.1	1282.3	1923.4	2564.5	3740.0	5129.1	-	-
QF3150	QF3150INSERT	Red	11880	62.2	124.4	373.2	746.4	1119.5	1492.7	2176.9	-	-	-
	QF3150HINSERT	White	22401	117.3	234.6	703.7	1407.4	2111.1	2814.8	4105.0	-	-	-
	QF3150BINSERT	Blue	22401	117.3	234.6	703.7	1407.4	2111.1	2814.8	4105.0	-	-	-
QF10260	QF10260INSERT	Red	23748	124.3	248.7	746.0	1492.0	2238.1	2984.1	-	-	-	-
	QF10260HINSERT	White	44736	234.2	468.4	1405.3	2810.6	4216.0	5621.3	-	-	-	-
	QF10260BINSERT	Blue	44736	234.2	468.4	1405.3	2810.6	4216.0	5621.3	-	-	-	-

Note: ■ QUICK FLEX flexible couplings can sustain momentary peak torque loads up to 200 percent of their continuous torque rating.

Torque Ratings and Misalignment Tolerances

Table 7. QUICK FLEX Coupling Torque Ratings with Split Covers (Imperial)

Coupling Series	Insert Part No.	Insert Color	Continuous Torque in-lbs	HP Ratings @ Various RPM (Service Factor = 1)									
				50	100	300	600	900	1200	1750	2400	3600	5000
QF15	QF15INSERT	Red	1324	1.1	2.1	6.3	12.6	18.9	25.2	36.8	50.4	75.6	105.0
	QF15HINSERT	White	2594	2.1	4.1	12.3	24.7	37.0	49.4	72.0	98.8	148.2	205.8
	QF15BINSERT	Blue	2594	2.1	4.1	12.3	24.7	37.0	49.4	72.0	98.8	148.2	205.8
	QF15TINSERT	Black	4001	3.2	6.3	19.0	38.1	57.1	76.2	111.1	152.4	228.5	317.4
QF25	QF25INSERT	Red	4283	3.4	6.8	20.4	40.8	61.2	81.5	118.9	163.1	244.6	339.8
	QF25HINSERT	White	8077	6.4	12.8	38.4	76.9	115.3	153.8	224.3	307.6	461.4	640.8
	QF25BINSERT	Blue	8077	6.4	12.8	38.4	76.9	115.3	153.8	224.3	307.6	461.4	640.8
	QF25TINSERT	Black	12449	9.9	19.8	59.3	118.5	177.8	237.0	345.7	474.1	711.1	987.6
QF50	QF50INSERT	Red	8833	7.0	14.0	42.0	84.1	126.1	168.2	245.3	336.4	504.5	700.8
	QF50HINSERT	White	17502	13.9	27.8	83.3	166.6	249.9	333.2	486.0	666.5	999.7	1388.5
	QF50BINSERT	Blue	17502	13.9	27.8	83.3	166.6	249.9	333.2	486.0	666.5	999.7	1388.5
	QF50TINSERT	Black	26479	21.0	42.0	126.0	252.1	378.1	504.2	735.2	1008.3	1512.5	2100.7
QF100	QF100INSERT	Red	17723	14.1	28.1	84.4	168.7	253.1	337.4	492.1	674.9	1012.3	1406.0
	QF100HINSERT	White	35144	27.9	55.8	167.3	334.6	501.9	669.1	975.8	1338.3	2007.4	2788.1
	QF100BINSERT	Blue	35144	27.9	55.8	167.3	334.6	501.9	669.1	975.8	1338.3	2007.4	2788.1
	QF100TINSERT	Black	53642	42.6	85.1	255.3	510.7	766.0	1021.3	1489.5	2042.7	3064.0	4255.6
QF175	QF175INSERT	Red	30753	24.4	48.8	146.4	292.8	439.2	585.5	853.9	1171.1	1756.6	2439.7
	QF175HINSERT	White	58903	46.7	93.5	280.4	560.8	841.1	1121.5	1635.5	2243.0	3364.6	4673.0
	QF175BINSERT	Blue	58903	46.7	93.5	280.4	560.8	841.1	1121.5	1635.5	2243.0	3364.6	4673.0
	QF175TINSERT	Black	88257	70.0	140.0	420.1	840.2	1260.3	1680.4	2450.6	3360.8	5041.3	7001.7
QF250	QF250INSERT	Red	38864	30.8	61.7	185.0	370.0	555.0	740.0	1079.1	1479.9	2219.9	3083.2
	QF250HINSERT	White	77158	61.2	122.4	367.3	734.5	1101.8	1469.1	2142.4	2938.2	4407.3	6121.2
	QF250BINSERT	Blue	77158	61.2	122.4	367.3	734.5	1101.8	1469.1	2142.4	2938.2	4407.3	6121.2
	QF250TINSERT	Black	118930	94.4	188.7	566.1	1132.2	1698.3	2264.4	3302.3	4528.9	6793.3	9435.1
QF500	QF500INSERT	Red	75114	59.6	119.2	357.5	715.1	1072.6	1430.2	2085.7	2860.4	4290.5	5959.1
	QF500HINSERT	White	144372	114.5	229.1	687.2	1374.4	2061.6	2748.9	4008.7	5497.7	8246.6	11453.6
	QF500BINSERT	Blue	144372	114.5	229.1	687.2	1374.4	2061.6	2748.9	4008.7	5497.7	8246.6	11453.6
	QF500TINSERT	Black	219429	174.1	348.2	1044.5	2089.0	3133.5	4177.9	6092.8	8355.9	12533.8	17408.1
QF1000	QF1000INSERT	Red	106208	84.3	168.5	505.6	1011.1	1516.7	2022.2	2949.1	4044.4	6066.6	-
	QF1000HINSERT	White	203746	161.6	323.3	969.8	1939.7	2909.5	3879.3	5657.4	7758.7	11638.0	-
	QF1000BINSERT	Blue	203746	161.6	323.3	969.8	1939.7	2909.5	3879.3	5657.4	7758.7	11638.0	-
	QF1000TINSERT	Black	310466	246.3	492.6	1477.8	2955.6	4433.5	5911.3	8620.6	11822.6	17733.9	-
QF1890	QF1890INSERT	Red	175840	139.5	279.0	837.0	1674.0	2511.0	3348.0	4882.5	-	-	-
	QF1890HINSERT	White	344594	273.4	546.8	1640.3	3280.5	4920.8	6561.1	9568.3	-	-	-
	QF1890BINSERT	Blue	344594	273.4	546.8	1640.3	3280.5	4920.8	6561.1	9568.3	-	-	-
	QF1890TINSERT	Black	553982	439.5	879.0	2637.0	5273.9	7910.9	10547.9	15382.3	-	-	-
QF3150	QF3150INSERT	Red	300387	238.3	476.6	1429.8	2859.7	4289.5	5719.4	8340.8	-	-	-
	QF3150HINSERT	White	566434	449.4	898.7	2696.2	5392.5	8088.7	10784.9	15728.0	-	-	-
	QF3150BINSERT	Blue	566434	449.4	898.7	2696.2	5392.5	8088.7	10784.9	15728.0	-	-	-
	QF3150TINSERT	Black	871139	691.1	1382.2	4146.6	8293.3	12439.9	16586.5	24188.7	-	-	-
QF10260	QF10260INSERT	Red	600494	476.4	952.8	2858.4	5716.7	8575.1	11433.4	16673.8	-	-	-
	QF10260HINSERT	White	1131179	897.4	1794.8	5384.4	10768.9	16153.3	21537.7	31409.2	-	-	-
	QF10260BINSERT	Blue	1131179	897.4	1794.8	5384.4	10768.9	16153.3	21537.7	31409.2	-	-	-
	QF10260TINSERT	Black	1670826	1325.5	2651.1	7953.2	15906.3	23859.5	31812.6	46393.4	-	-	-

Note: ■ QUICK FLEX flexible couplings can sustain momentary peak torque loads up to 200 percent of their continuous torque rating.

Torque Ratings and Misalignment Tolerances

Table 8. QUICK FLEX Coupling Torque Ratings with Split Covers (Metric)

Coupling Series	Insert Part No.	Insert Color	Continuous Torque Nm	kW Ratings @ Various RPM (Service Factor = 1)									
				50	100	300	600	900	1200	1750	2400	3600	5000
QF15	QF15INSERT	Red	150	0.8	1.6	4.7	9.4	14.1	18.8	27.4	37.6	56.4	78.3
	QF15HINSERT	White	293	1.5	3.1	9.2	18.4	27.6	36.8	53.7	73.7	110.5	153.5
	QF15BINSERT	Blue	293	1.5	3.1	9.2	18.4	27.6	36.8	53.7	73.7	110.5	153.5
	QF15TINSERT	Black	452	2.4	4.7	14.2	28.4	42.6	56.8	82.8	113.6	170.4	236.7
QF25	QF25INSERT	Red	484	2.5	5.1	15.2	30.4	45.6	60.8	88.7	121.6	182.4	253.4
	QF25HINSERT	White	913	4.8	9.6	28.7	57.3	86.0	114.7	167.2	229.4	344.0	477.8
	QF25BINSERT	Blue	913	4.8	9.6	28.7	57.3	86.0	114.7	167.2	229.4	344.0	477.8
	QF25TINSERT	Black	1407	7.4	14.7	44.2	88.4	132.6	176.8	257.8	353.5	530.3	736.5
QF50	QF50INSERT	Red	998	5.2	10.5	31.4	62.7	94.1	125.4	182.9	250.8	376.2	522.6
	QF50HINSERT	White	1978	10.4	20.7	62.1	124.2	186.4	248.5	362.4	497.0	745.5	1035.4
	QF50BINSERT	Blue	1978	10.4	20.7	62.1	124.2	186.4	248.5	362.4	497.0	745.5	1035.4
	QF50TINSERT	Black	2992	15.7	31.3	94.0	188.0	282.0	376.0	548.3	751.9	1127.9	1566.5
QF100	QF100INSERT	Red	2003	10.5	21.0	62.9	125.8	188.7	251.6	367.0	503.3	754.9	1048.5
	QF100HINSERT	White	3971	20.8	41.6	124.7	249.5	374.2	499.0	727.7	998.0	1496.9	2079.1
	QF100BINSERT	Blue	3971	20.8	41.6	124.7	249.5	374.2	499.0	727.7	998.0	1496.9	2079.1
	QF100TINSERT	Black	6061	31.7	63.5	190.4	380.8	571.2	761.6	1110.7	1523.2	2284.9	3173.4
QF175	QF175INSERT	Red	3475	18.2	36.4	109.2	218.3	327.5	436.6	636.8	873.3	1309.9	1819.3
	QF175HINSERT	White	6656	34.8	69.7	209.1	418.2	627.2	836.3	1219.6	1672.6	2509.0	3484.7
	QF175BINSERT	Blue	6656	34.8	69.7	209.1	418.2	627.2	836.3	1219.6	1672.6	2509.0	3484.7
	QF175TINSERT	Black	9973	52.2	104.4	313.3	626.5	939.8	1253.1	1827.4	2506.2	3759.3	5221.2
QF250	QF250INSERT	Red	4391	23.0	46.0	138.0	275.9	413.9	551.8	804.7	1103.6	1655.4	2299.2
	QF250HINSERT	White	8718	45.6	91.3	273.9	547.8	821.6	1095.5	1597.6	2191.0	3286.5	4564.6
	QF250BINSERT	Blue	8718	45.6	91.3	273.9	547.8	821.6	1095.5	1597.6	2191.0	3286.5	4564.6
	QF250TINSERT	Black	13438	70.4	140.7	422.1	844.3	1266.4	1688.6	2462.5	3377.2	5065.8	7035.8
QF500	QF500INSERT	Red	8487	44.4	88.9	266.6	533.2	799.9	1066.5	1555.3	2133.0	3199.5	4443.7
	QF500HINSERT	White	16313	85.4	170.8	512.5	1024.9	1537.4	2049.8	2989.3	4099.7	6149.5	8541.0
	QF500BINSERT	Blue	16313	85.4	170.8	512.5	1024.9	1537.4	2049.8	2989.3	4099.7	6149.5	8541.0
	QF500TINSERT	Black	24794	129.8	259.6	778.9	1557.8	2336.6	3115.5	4543.4	6231.0	9346.5	12981.3
QF1000	QF1000INSERT	Red	12001	62.8	125.7	377.0	754.0	1131.0	1508.0	2199.1	3015.9	4523.9	-
	QF1000HINSERT	White	23022	120.5	241.1	723.2	1446.4	2169.6	2892.8	4218.7	5785.7	8678.5	-
	QF1000BINSERT	Blue	23022	120.5	241.1	723.2	1446.4	2169.6	2892.8	4218.7	5785.7	8678.5	-
	QF1000TINSERT	Black	35081	183.7	367.3	1102.0	2204.0	3306.1	4408.1	6428.4	8816.1	13224.2	-
QF1890	QF1890INSERT	Red	19869	104.0	208.1	624.2	1248.3	1872.5	2496.6	3640.9	-	-	-
	QF1890HINSERT	White	38937	203.9	407.7	1223.2	2446.3	3669.5	4892.6	7135.1	-	-	-
	QF1890BINSERT	Blue	38937	203.9	407.7	1223.2	2446.3	3669.5	4892.6	7135.1	-	-	-
	QF1890TINSERT	Black	62597	327.7	655.5	1966.4	3932.8	5899.2	7865.6	11470.6	-	-	-
QF3150	QF3150INSERT	Red	33942	177.7	355.4	1066.2	2132.5	3198.7	4265.0	6219.7	-	-	-
	QF3150HINSERT	White	64004	335.1	670.2	2010.6	4021.2	6031.8	8042.4	11728.5	-	-	-
	QF3150BINSERT	Blue	64004	335.1	670.2	2010.6	4021.2	6031.8	8042.4	11728.5	-	-	-
	QF3150TINSERT	Black	98434	515.4	1030.7	3092.2	6184.3	9276.5	12368.6	18037.6	-	-	-
QF10260	QF10260INSERT	Red	67852	355.2	710.5	2131.5	4263.0	6394.5	8526.0	12433.7	-	-	-
	QF10260HINSERT	White	127817	669.2	1338.4	4015.2	8030.4	12045.6	16060.8	23421.9	-	-	-
	QF10260BINSERT	Blue	127817	669.2	1338.4	4015.2	8030.4	12045.6	16060.8	23421.9	-	-	-
	QF10260TINSERT	Black	188794	988.4	1976.9	5930.7	11861.4	17792.1	23722.8	34595.7	-	-	-

Note: ■ QUICK FLEX flexible couplings can sustain momentary peak torque loads up to 200 percent of their continuous torque rating.

Torque Ratings and Misalignment Tolerances

Table 9. QUICK FLEX Coupling Misalignment Tolerances

Coupling Series	Radial Misalignment Tolerance	Axial Misalignment Tolerance	Angular Misalignment Tolerance
	mm in	mm in	
QF5	0.51	1.98	2°
	0.020	0.078	
QF15	0.99	2.95	2°
	0.039	0.116	
QF25	0.99	2.95	2°
	0.039	0.116	
QF50	0.97	2.95	2°
	0.038	0.116	
QF100	1.47	3.96	2°
	0.058	0.156	
QF175	1.47	4.45	1.3°
	0.058	0.175	
QF250	1.47	5.94	1.3°
	0.058	0.234	
QF500	1.47	5.94	1°
	0.058	0.234	
QF1000	1.47	5.94	1°
	0.058	0.234	
QF1890	1.47	7.92	1°
	0.058	0.312	
QF3150	1.98	7.92	1°
	0.078	0.312	
QF10260	1.98	7.92	1°
	0.078	0.312	

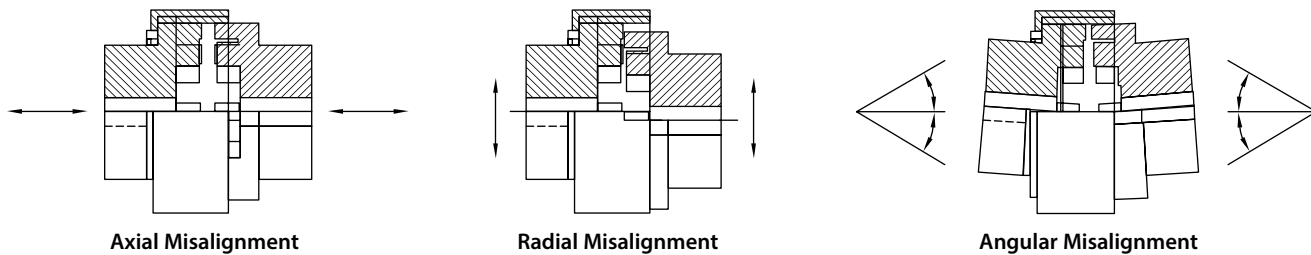

Fig. 4. Types of misalignment.

Engineering

Coupling Service Factors for Applications

Coupling Service Factors for Applications

Suggested service factors listed are typical values based on normal operation of the mechanical power transmission system.

Application	Service Factor
Aerators	2.5
Aggregate Processing, Cement, Mining Kilns	
Direct or on Line Shaft of Reducer	
With Final Drive Machined Spur Gears	2.25
With Single Helical or Herringbone Gears	2.0
Crushers, Ore or Stone	2.75
Dryer, Rotary	2.0
Grizzly	2.25
Hammermill or Hog	2.0
Tumbling Mill or Barrel	2.0
Agitators (also see Mixers)	
Vertical, Horizontal, Screw, Propeller, Paddle	1.25
Barge Haul Puller	1.75
Blowers	
Centrifugal	1.5
Lobe or Vane	1.5
Brewing and Distilling	
Bottle- and Can-Filling Machines	1.5
Brew Kettle	1.25
Cookers, Continuous Duty	1.5
Lauter Tub	1.75
Mash Tub	1.5
Scale Hopper, Frequent Peaks	2.0
Clarifier or Classifier	1.25
Clay-Working Industry	
Brick Press, Briquette Machine, Clay-Working Machine, Pug Mill	2.0
Compressors	
Centrifugal	1.25
Rotary, Lobe or Vane	1.5
Rotary, Screw	1.5
Reciprocating	
Direct Connected	Refer to Equipment OEM
Without Flywheels	Refer to Equipment OEM
With Flywheel and Gear between Compressor and Prime Monitor	
One Cylinder, Single Acting	3.0
One Cylinder, Double Acting	3.0
Two Cylinders, Single Acting	3.0
Two Cylinders, Double Acting	3.0
Three Cylinders, Single Acting	3.0
Three Cylinders, Double Acting	2.0
Four or More Cyl., Single Acting	2.5
Four or More Cyl., Double Acting	2.5

Application	Service Factor
Conveyors	
Apron, Assembly, Belt, Chain, Flight, Screw	1.75
Bucket	1.75
Live Roll, Shaker and Reciprocating	3.0
Bridge, Travel or Trolley	2.50
Dredgers	
Cable Reel	2.0
Conveyors	1.50
Cutter Head, Jig Drive	2.5
Maneuvering Winch	1.75
Pumps (Uniform Load)	1.75
Screen Drive, Stacker	2.0
Utility Winch	2.0
Dynamometer	1.5
Elevators: Bucket, Centrifugal Discharge	1.75
Exciter, Generator	1.5
Extruder, Plastic	1.5
Fans	
Centrifugal	1.25
Cooling Tower	2.0
Forced Draft-Across the Line Start	1.75
Feeders	
Apron, Belt, Disc, Screw	1.25
Reciprocating	2.5
Food Industry	
Beet Slicer	2.0
Bottle- and Can-Filling Machine	1.5
Cereal Cooker	1.5
Dough Mixer, Meat Grinder	2.0
Forced-Draft Motor Driven through Fluid or Electro-Slip Clutch	1.25
Gas Recirculating	1.50
Induced Draft with Damper Control or Blade Cleaner	1.50
Induced Draft without Controls	2.0
Generators	
Even Load	1.25
Hoist or Railway Service	1.75
Welder Load	2.0
Hammermill	1.75
Laundry Washer or Tumbler	2.0
Line Shafts, Any Processing Machinery	1.5

Continued on next page.

Engineering

Coupling Service Factors for Applications

Coupling Service Factors for Applications

Suggested service factors listed are typical values based on normal operation of the mechanical power transmission system.

Application	Service Factor
Lumber	
Band Resaw	2.0
Circular Resaw, Cutoff	2.0
Edger, Head Rig, Hog	2.5
Gang Saw (Reciprocating)	3.0
Log Haul	2.5
Planer	2.0
Rolls, Non-Reversing	1.5
Rolls, Reversing	2.5
Sawdust Conveyor	1.5
Slab Conveyor	2.0
Sorting Table	1.75
Trimmer	2.0
Machine Tools	
Auxiliary and Traverse Drive	1.0
Bending Roll, Notching Press, Punch, Press, Planer, Plate-Reversing	1.75
Main Drive	1.5
Metal Rolling Mills	
Coilers (Up or Down) Cold Mill Only	1.75
Coilers (Up or Down) Hot Mill Only	2.25
Coke Plants	
Pusher Ram Drive	2.75
Door Opener	2.25
Pusher or Larry Car Traction Drive	3.25
Continuous Caster	2.0
Cold Mills	
Strip Mills	Refer to Equipment OEM
Temper Mills	Refer to Equipment OEM
Cooling Beds	1.75
Drawbench	2.25
Feed Rolls: Blooming Mills	3.25
Furnace Pushers	2.25
Hot and Cold Saws	2.25
Hot Mills	
Strip or Sheet Mills	Refer to Equipment OEM
Reversing Blooming	Refer to Equipment OEM
Slabbing Mills	Refer to Equipment OEM
Edger Drives	Refer to Equipment OEM
Ingot Cars	2.25
Manipulators	3.25
Merchant Mills	Refer to Equipment OEM

Application	Service Factor
Mill Tables	
Roughing Breakdown Mills	3.25
Hot Bed or Transfer (Non-Reversing)	1.75
Runout (Reversing)	3.25
Runout (Non-Reversing, Non-Plugging)	2.25
Reel Drives	2.0
Rod Mills	Refer to Equipment OEM
Screwdown	2.25
Seamless-Tube Mills	
Piercer	3.25
Thrust Block	2.25
Tube-Conveyor Rolls	2.25
Reeler	2.25
Kick Out	2.25
Shear, Croppers	Refer to Equipment OEM
Sideguards	3.25
Skelp Mills	Refer to Equipment OEM
Slitters (Steel Mill Only)	2.0
Soaking Pit Cover Drives	
Lift	1.25
Travel	2.25
Straighteners	2.25
Unscramblers (Billet Bundle Busters)	2.25
Wire-Drawing Machinery	2.0
Mixers (also see Agitators)	
Concrete	1.75
Muller	1.5
Oil Industry	
Chiller	1.50
Oilwell Pumping (Not Over 150 Percent Peak Torque)	2.5
Paraffin Filter Press	1.75
Rotary Kiln	2.5
Paper Mills	
Barker, Auxiliary, Hydraulic	2.5
Barker, Mechanical	2.5
Barker, Drum L.S. Shaft of Reducer with Final Drive	
Helical or Herringbone Gear	2.5
Machined Spur Gear	3.0
Cast Tooth Spur Gear	3.0
Beater and Pulper	2.0
Bleachers, Coaters	1.5
Calendar and Super Calendar	2.0
Chipper	3.0
Converting Machine	1.50
Couch	2.00
Cutter, Felt Whipper	2.25

Continued on next page.

Engineering

Coupling Service Factors for Applications

Coupling Service Factors for Applications

Suggested service factors listed are typical values based on normal operation of the mechanical power transmission system.

Application	Service Factor
Cylinder, Dryer	2.00
Felt Stretcher	1.75
Fourdrinier	2.00
Jordan	2.5
Log Haul	2.5
Line Shaft	1.75
Press	2.0
Pulp Grinder	2.0
Reel, Rewinder, Winder	2.0
Stock Chest, Washer, Thickener	1.75
Stock Pumps, Centrifugal	
Constant Speed	1.25
Frequent Speed Changes Under Load	1.5
Suction Roll	2.0
Press, Printing	1.5
Pug Mill	1.75
Pulverizers	
Hammermill and Hog	1.75
Roller	1.5
Pumps: Centrifugal	
Constant Speed	1.0
Frequent Speed Changes Under Load	1.75
Descaling, with Accumulators	1.75
Gear, Rotary or Vane	1.75
Pumps: Reciprocating	
One Cylinder, Single or Double Acting	3.0
Two Cylinder, Single Acting	2.5
Two Cylinder, Double Acting	2.0
Three or More Cylinders	2.0
Rubber Industry	
Calendar	2.25
Cracker, Plasticolour	2.5
Extruder	2.0
Tire and Tube-Press Opener (Peak Torque)	1.5
Warming Mill	
One or Two Mills in Line	2.0
Three or More Mills in Line	2.50
Washer	2.75
Screens	
Air Washing	1.5
Grizzly	2.5
Rotary Coal or Sand	2.0
Vibrating	2.5
Water	1.5
Sewage-Disposal Equipment	
Bar Screen, Chemical Feeders, Collectors, Dewatering Screen, Grit Collector	1.5
Mill Stands, Turbine Driven with all Helical or Herringbone Gears	1.75

Application	Service Factor
Electric-Drive or Steam-Engine Drive with Helical or Herringbone	2.0
Stoker	1.0
Sugar Industry	
Cone Carrier and Leveler	2.25
Cane Knife and Crusher	2.5
Mill Stands, Turbine Driver with all Helical or Herringbone Gears	1.75
Electric-Drive or Steam-Engine Drive with Helical, Herringbone or Spur Gears with any Prime Mover	2.0
Textile Industry	
Batcher	1.5
Calendar, Card Machine	1.75
Cloth-Finishing Machine	1.75
Dry Can, Loom	1.75
Dyeing Machinery	1.5
Knitting Machine	Refer to Equipment OEM
Mangle, Napper, Soaper	1.5
Spinner, Tenter Frame, Winder	1.75
Tumbling Barrel	2.0
Winch, Maneuvering: Dredge, Marine	1.5
Windlass	1.5

Engine Drive Service Factors

Service factors for engine drives are those required for applications where good flywheel regulation prevents torque fluctuation greater than 20 percent. For drives where torque fluctuations are greater or where the operation is near a serious critical or torsional vibration, a mass elastic study is necessary.

To determine an engine drive service factor, first determine the application service factor for motors. Then, use that to find the correct engine service factor in the table below. When the application service factor for motors is greater than 2.0 or where one-, two- or three-cylinder engines are involved, please contact your Lovejoy Application engineer with complete application details for an engineering review.

Table 10. Engine Service Factor

Application Service Factor	Engine Service Factor	
	4 to 5 Cylinders	6+ Cylinders
1.00	2.00	1.50
1.25	2.25	1.75
1.50	2.50	2.00
1.75	2.75	2.25
2.00	3.00	2.50

Engineering

Coupling Insert Chemical Compatibility

A – Little to no effect B – Minor to moderate effect C – Severe effect to destruction N – No data. Test prior to use.	Urethane
Acetaldehyde	C
Acetamide	N
Acetic Acid	C
Acetic Anhydride	C
Acetone	C
Acetyl Bromide	C
Acetyl Chloride	C
Acetylene	C
Adipic Acid	A
Aero Shell Grease	B
Aero Lubriplate	A
Aero Safe 2300	N
Aerozene 50	N
Aluminum Acetate	N
Aluminum Bromide	N
Aluminum Chloride	B
Aluminum Sulfate	B
Ammonia	B
Ammonium Carbonate	B
Ammonium Chloride	N
Ammonium Hydroxide	B
Ammonium Nitrate	B
Ammonium Persulfate	B
Ammonium Sulfate	B
Ammonium Sulfide	B
Ammonium Thiocyanate	B
Amonnium Acetate	C
Amyl Acetate	C
Amyl Alcohol	C
Aniline	C
Aniline Hydrochloride	C
Animal Fats and Oils	B
Antimony Salts	B
Aqua Regia	C
Arsenic Salts	B
ASTM Oil #1	A
ASTM Oil #2	B
ASTM Oil #3	B
ASTM Reference Fuel A	A
ASTM Reference Fuel B	B
Atlantic Oil	A
Barium Carbonate	B
Barium Hydroxide	A
Beer	A
Benzaldehyde	B
Benzene	C
Benzoic Acid	B
Black Sulphate Liquors	N

A – Little to no effect B – Minor to moderate effect C – Severe effect to destruction N – No data. Test prior to use.	Urethane
Bleach Solutions	N
Boric Acid	A
Brake Fluid	N
Bromine	B
Bunker Oil	A
Butane	A
Butyl Acetate	C
Butyl Alcohol	B
Calcium Carbonate	B
Calcium Chloride	A
Calcium Hydroxide	A
Calcium Nitrate	B
Calcium Sulfate	B
Carbon Dioxide	A
Carbon Disulfide	B
Carbon Monoxide	A
Carbon Tetrachloride	C
Chlorine	N
Chloroacetic Acid	C
Chloroform	C
Chromic Acid	C
Chromium Potassium Sulfate	B
Citric Acid	B
Corn Oil	A
Cottonseed Oil	A
Cresol	C
Crude Oil	B
Cupric Chloride	A
Cupric Nitrate	B
Cupric Sulfate	B
Cutting Oil	B
Cyclohexane	B
Cyclohexanone	C
Dibutyl Phthalate	C
Dichlorobenzene	C
Diesel Fuel	B
Diester Oil	B
Dimethyl Acetamide	C
Dimethyl Formamide	C
Dodecyl Mercaptan	B
DTE Oil	B
Dibutyl Ether	B
EP Lubes	A
Esso #90 Lube Oil	A
Ether	B
Ethyl Acetate	C
Ethyl Alcohol (Ethanol)	C
Formic Acid	C

A – Little to no effect B – Minor to moderate effect C – Severe effect to destruction N – No data. Test prior to use.	Urethane
Freon, 12 or 113	A
Fuel Oil	B
Gasoline	B
Glucose	A
Glue	N
Glycerin	A
Heptane	A
Hexane	A
Hydrazine	C
Hydrobromic Acid	B
Hydrocarbon Oil	A
Hydrochloric Acid	B
Hydrofluoric Acid	B
Hydrogen	A
Hydrogen Peroxide	B
Hydrogen Sulfide	C
Hydrologic Acid	B
Iodine	A
Isobutyl Alcohol	N
Isopropyl Chloride	N
Isopropyl Ether	B
Isopropyl Alcohol (Propanol)	B
JP4 Oil	B
JP5 and 6 Oil	C
Kerosene	B
Lactic Acid	B
Lead Acetate	B
Linseed Oil	B
Liquefied Petroleum Gas	A
Lubrication Oil	B
Lye	N
Magnesium Chloride	N
Magnesium Hydroxide	A
Magnesium Salts	B
Malaic Acid	C
Mercury	B
Methyl Alcohol (Methanol)	A
Methyl Ethyl Ketone	C
Methylene Chloride	C
MIL-D-5606 Oil	C
MIL-L-7808 Oil	B
Mineral Oil	A
Mineral Spirits	N
Naphthalene	B
Natural Gas	B
Nickel Salts	C
Oxygen	A

Continued on next page.

Engineering

Coupling Insert Chemical Compatibility

A – Little to no effect B – Minor to moderate effect C – Severe effect to destruction N – No data. Test prior to use.	Urethane
Ozone	A
Paimitic Acid	A
Paint Thinner	B
Peanut Oil	A
Perchloric Acid	C
Perchloroethylene	C
Petroleum	B
Phenol (Carbolic Acid)	C
Phosphoric Acid	C
Potassium Cyanide	A
Potassium Salts	B
Propane	B
Propyl Alcohol	B
Propylene Glycol	B
Pydraul Oil	C
SAE #10 Oil	A
Seawater	A
Silicic Acid	B
Silver Nitrate	B
Skydrol Oil	C
Soap	B
Sodium Acetate	A
Sodium Bicarbonate	B
Sodium Borate	B
Sodium Carbonate	B
Sodium Chloride	B
Sodium Cyanide	B
Sodium Hydrosulfite	B
Sodium Hydroxide	B
Sodium Hypochlorite	C
Sodium Nitrate	B
Sodium Silicate	A
Sodium Sulfate	B
Sodium Sulfide	B
Steam	C
Styrene	B
Sulfur Dioxide	B
Sulfuric Acid	C
Tannic Acid	A
Tartaric Acid	A
Toluene	C
Transformer Oil	B
Turpentine	C
Urea	B
Varnish	B
Water	B

Standard Coupling Installation

Please complete the following steps to install QUICK FLEX couplings.

You should have the following pieces before starting the job:

- Two hubs
- One insert
- One cover with included hardware

Note: It is critical to identify what style cover you are using, as this will change the hardware included, as well as the installation procedure. A mismatch between the coupling and the application may result in less than optimal performance.

There are four types of covers (fig. 5):

- **High-speed cover:** QF5 through QF175 use standard snap ring to secure cover in place. QF250 and larger use eight bolts with lock washers.
- **Low-speed split cover:** This cover is free-floating and is located outside the shoulders of the two hubs. All sizes come with four bolts for securing the two halves together around the insert.
- **High-speed split cover:** QF15 through QF250 use eight bolts around the rim to secure the two halves together, QF500 through QF1890 use 16 bolts, and QF3150 and larger use 20 bolts. QF250 and larger use eight bolts with lock washers to secure the cover to one of the hubs.
- **High-performance split cover:** This cover is free-floating and is located on the insert with an internal radial groove. All sizes come with four socket-head cap screws for securing the two halves together around the insert.

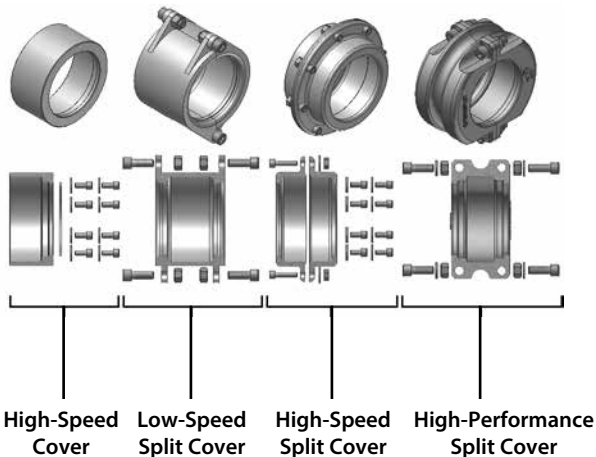

Fig. 5. QUICK FLEX cover types and included hardware.

Installation

1. Check the bore size of the coupling halves and the shafts. Ensure that they are the correct bore size to fit the application.
2. If the coupling does not fit easily, clean and deburr the shafts.
3. Identify cover style:
 - d. **If using a high-speed cover**, it should be placed on the driven shaft. If space does not permit, then it can be mounted on the drive shaft. If cover uses a snap ring, slide the snap ring down the shaft, then slide the cover onto shaft with the larger opening facing the shaft separation.
 - e. **If using a low-speed or high-performance split cover**, leave cover aside and continue to step 4.
 - f. **If using a high-speed split cover**, QF250 and larger, use bolts and washers to secure in place. Slide one half down each shaft before installing hubs. Do not bolt into place until installation is complete.

Note: Standard hubs are supplied with a clearance fit and should slide onto the shaft without excessive force. If the hubs have been ordered with interference fit, then industry standards suggest heating the coupling halves to approximately 300° C (572° F) before installing on shafts. If not heated properly, the couplings will not fit on the hub properly.

⚠ WARNING

Failure to observe the following warnings could create a risk of death or serious injury.

Contact with moving parts and/or rotating shafts poses a risk of serious injury. Proper guards in accordance with OSHA and American Society of Mechanical Engineers standards must be installed on all power transmission equipment. Power transmission equipment should not be started if proper guarding is not in place. Observe all required lock out/tag out procedures when servicing power transmission equipment.

Standard Coupling Installation

4. Install the first hub. It should be mounted so the end of the shaft is flush with surface "A" as shown in fig. 6. It is acceptable for the shaft to extend past "A" as long as it is not past the teeth shown as "B."
5. Install the second hub with the insert in place. This will set the hubs at the minimum hub gap (G_{Min}) dimension, ensuring proper clearance. For specific G_{Min} and G_{Max} dimensions see table 12.
6. Tighten both hubs securely to the shafts.
7. Check coupling for misalignment (table 13) and align as necessary.
8. Install the cover:
 - a. **High-speed cover:** Slide the cover over the hub and insert until fully rested against the shoulder of the hub. QF5 through QF175 use standard snap rings to hold the cover in place. QF250 and larger couplings use eight bolts and washers. Use the included hardware to secure the cover.
 - b. **Low-speed or high-performance split cover:** Place each half over the insert and secure using the four bolt/washer/nut hardware combinations supplied. For the high-performance split cover bolt tightening torque ratings, see table 11.
 - c. **High-speed split cover:** Slide the two cover halves over the hub and insert until faces meet. Install the radial outer bolts used to secure the two halves together. Install the bolts to secure the cover to **one** hub.

Table 11. High-Performance Split Cover Tightening Torque

Coupling Series	Bolts mm	Tightening Torque Nm ft-lbs
QF15HPCOVER	(4) M6 X 25MM	10.8 8
QF25HPCOVER	(4) M10 X 35MM	40.7 30
QF50HPCOVER	(4) M12 X 45MM	101.7 75
QF100HPCOVER	(4) M12 X 60MM	101.7 75
QF175HPCOVER	(4) M16 X 65MM	169.5 125
QF250HPCOVER	(4) M20 X 60MM	203.4 150
QF500HPCOVER	(4) M20 X 60MM	203.4 150

Revolutions Per Minute (RPM) and Balance

The QUICK FLEX coupling is machined on all surfaces and thus its dynamic balance is good. If the coupling is run at a high speed, it is important that the keys used to attach the hubs are the same length as the hub. The set screws should also be changed to full length to fill the hole. Please refer to table 14 for maximum RPM ratings.

Note: Shaft should penetrate to base of teeth and hubs should be set at G_{Min} . Otherwise, the coupling may not deliver maximum torque.

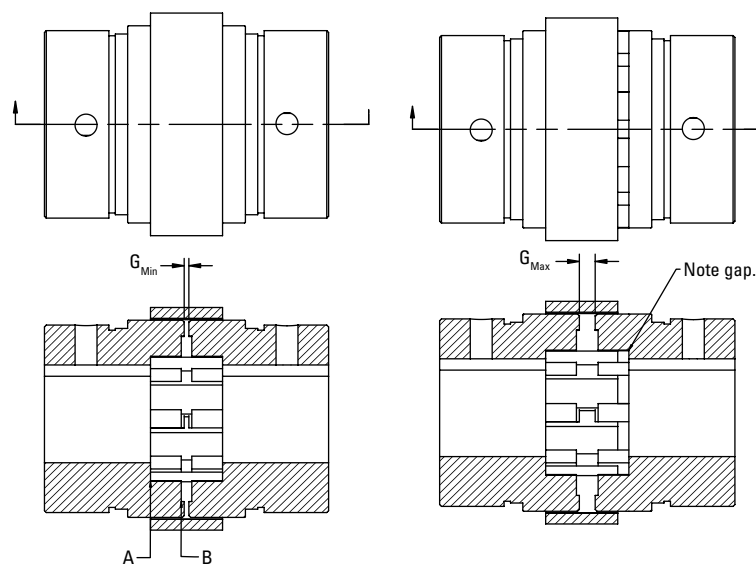

Fig. 6. Proper shaft-to-hub engagement.

Standard Coupling Installation

Table 12. QUICK FLEX Standard Coupling Hub Gap (G) Dimensions

Coupling Series	High-Speed Cover		Low-Speed Split Cover		High-Speed Split Cover		High-Performance Split Cover	
	G _{Min}	G _{Max}	G _{Min}	G _{Max}	G _{Min}	G _{Max}	G _{Min}	G _{Max}
	mm in	mm in	mm in	mm in	mm in	mm in	mm in	mm in
QF5	1.60	2.34	N/A	N/A	N/A	N/A	N/A	N/A
	0.063	0.092						
QF15	2.27	2.64	2.01	2.51	2.27	2.64	2.27	2.64
	0.089	0.104	0.079	0.099	0.089	0.104	0.089	0.104
QF25	2.54	3.30	2.54	2.90	2.54	3.30	2.54	3.30
	0.100	0.130	0.100	0.114	0.100	0.130	0.100	0.130
QF50	2.67	4.60	1.52	2.29	2.67	4.60	2.67	3.56
	0.105	0.181	0.060	0.090	0.105	0.181	0.105	0.140
QF100	4.57	5.36	5.62	8.13	5.62	8.13	5.62	8.13
	0.180	0.211	0.221	0.320	0.221	0.320	0.221	0.320
QF175	6.43	7.44	6.43	7.98	6.43	7.98	6.43	7.98
	0.253	0.293	0.253	0.314	0.253	0.314	0.253	0.314
QF250	4.32	5.31	4.32	5.31	4.32	5.31	4.32	5.31
	0.170	0.209	0.170	0.209	0.170	0.209	0.170	0.209
QF500	4.98	6.35	N/A	N/A	4.98	8.51	4.98	8.51
	0.196	0.250			0.196	0.335	0.196	0.335
QF1000	6.02	8.86	N/A	N/A	6.02	8.86	N/A	N/A
	0.237	0.349			0.237	0.349		
QF1890	6.35	8.81	N/A	N/A	7.32	10.08	N/A	N/A
	0.250	0.347			0.288	0.397		
QF3150	4.24	7.85	N/A	N/A	4.24	7.85	N/A	N/A
	0.167	0.309			0.167	0.309		
QF10260	5.99	10.77	N/A	N/A	5.99	10.77	N/A	N/A
	0.236	0.424			0.236	0.424		

Standard Coupling Installation

Table 13. QUICK FLEX Standard Coupling Misalignment Tolerances

Coupling Series	Radial Misalignment Tolerance	Axial Misalignment Tolerance	Angular Misalignment Tolerance
	mm in	mm in	
QF5	0.51	1.98	2°
	0.020	0.078	
QF15	0.99	2.95	2°
	0.039	0.116	
QF25	0.99	2.95	2°
	0.039	0.116	
QF50	0.97	2.95	2°
	0.038	0.116	
QF100	1.47	3.96	2°
	0.058	0.156	
QF175	1.47	4.45	1.3°
	0.058	0.175	
QF250	1.47	5.94	1.3°
	0.058	0.234	
QF500	1.47	5.94	1°
	0.058	0.234	
QF1000	1.47	5.94	1°
	0.058	0.234	
QF1890	1.47	7.92	1°
	0.058	0.312	
QF3150	1.98	7.92	1°
	0.078	0.312	
QF10260	1.98	7.92	1°
	0.078	0.312	

Table 14. QUICK FLEX Standard Coupling Maximum RPM Ratings

Coupling Series	High-Speed Cover	Low-Speed Split Cover	High-Speed Split Cover	High-Performance Split Cover
	RPM	RPM	RPM	RPM
QF5	12000	N/A	N/A	N/A
QF15	9000	400	9000	9000
QF25	7000	375	7000	7000
QF50	6000	350	6000	6000
QF100	4800	300	4800	4800
QF175	4200	250	4200	4200
QF250	3800	200	3800	3800
QF500	3400	N/A	3400	3400
QF1000	3000	N/A	3000	N/A
QF1890	2400	N/A	2400	N/A
QF3150	2000	N/A	2000	N/A
QF10260	1200	N/A	1200	N/A

Note: ■ Maximum RPM ratings are for off-the-shelf QUICK FLEX couplings. If your application requires higher RPM ratings, the couplings should be dynamically balanced.

Single-Ended Spacer Coupling Installation

Please complete the following steps to install QUICK FLEX single-ended spacer couplings.

You should have the following pieces before starting the job:

- One coupling hub
- One flanged hub
- One spacer body
- One insert
- One cover with included hardware

Note: It is critical to identify what style cover you are using, as this will change the hardware included, as well as the installation procedure. A mismatch between the coupling and the application may result in less than optimal performance.

There are four types of covers (fig. 7):

- **High-speed cover:** QF5 through QF175 use a standard snap ring to secure cover in place. QF250 and larger use eight bolts with lock washers.
- **Low-speed split cover:** This cover is free-floating and is located outside the shoulders of the two hubs. All sizes come with four bolts for securing the two halves together around the insert.
- **High-speed split cover:** This cover will be supplied in four pieces to fit over the spacer body. QF15 through QF250 use eight bolts around the rim to secure the two halves together, QF500 through QF1890 use 16 bolts, and QF3150 and larger use 20 bolts. QF250 and larger use eight bolts with lock washers to secure the cover to the hub.
- **High-performance split cover:** This cover is free-floating and is located on the insert with an internal radial groove. All sizes come with four socket-head cap screws for securing the two halves together around the insert.

Installation

1. The QUICK FLEX single-ended spacer coupling should be oriented with the flanged hub on the drive shaft and the coupling hub with insert on the driven shaft (fig. 8).
2. Check the bore size of the coupling hub and flanged hub to the shafts. Ensure that they are the correct bore size to fit the application.
3. If the coupling does not fit easily, clean and deburr the shafts.
4. Identify cover style:
 - e. **If using a high-speed cover,** it should be placed on one of the shafts. If cover uses a snap ring, slide the snap ring down the shaft, then slide the cover onto shaft with the larger opening facing the shaft separation.
 - f. **If using a low-speed or high-performance split cover,** leave cover aside and continue to step 5.
 - g. **If using a high-speed split cover,** QF250 and larger, use bolts and washers to secure in place. In some instances, one or both vertically split pieces cover halves will also be split horizontally. The horizontally split half should be placed on the spacer body side. If both halves are split then splits should be aligned 90 degrees from each other when bolted together. Do not bolt to coupling hub until installation is complete.
5. Install the coupling hub. It should be mounted so the end of the shaft is flush with surface "A" as shown in fig. 8. It is acceptable for the shaft to extend past "A" as long as it is not past the teeth shown as "B."
6. Install the flanged hub using the spacer body and insert to locate the flanged hub on the drive shaft. This will set the hubs at the minimum hub gap (G_{Min}) dimension when the insert is tight between the coupling hub and spacer body, ensuring proper clearance. For specific G_{Min} and G_{Max} dimensions see table 16.

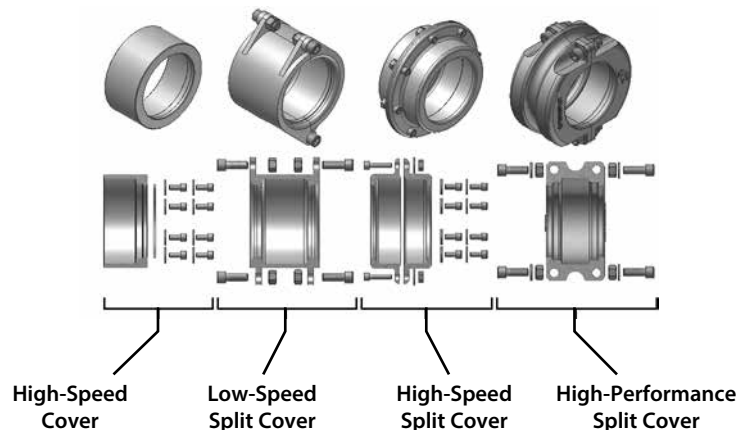

Fig. 7. QUICK FLEX cover types and included hardware.

Single-Ended Spacer Coupling Installation

7. Tighten the flanged hub and coupling hub securely to the shafts using the set screws.
8. Check coupling for misalignment (table 17) and align as necessary.
9. Install the cover:
 - a. **High-speed cover:** Slide the cover over the coupling hub and insert until fully rested against the shoulder of the coupling hub. QF5 through QF175 use standard snap rings to hold the cover in place. QF250 and larger couplings use eight bolts and washers. Use the included hardware to secure the cover.
 - b. **Low-speed or high-performance split cover:** Place each half over the insert and secure using the four bolt/washer/nut hardware combinations supplied. For the high-performance split cover bolt tightening torque ratings, see table 15.
 - c. **High-speed split cover:** Match the four pieces into two complete cover halves using the flange face detail to distinguish the two halves. For QF250 and larger, make sure the cover half with the eight holes for mounting to the coupling hub is on the coupling hub side, not the spacer side. Bolt the four pieces together using the supplied hardware, ensuring the splits in each half are rotated 90 degrees relative to each other. Install the bolts to secure the cover to the coupling hub.
10. Ensure the four spacer body bolts through the flange are tight along with all other bolts and set screws.

Note: Standard hubs are supplied with a clearance fit and should slide onto the shaft without excessive force. If the hubs have been ordered with interference fit, then heat the coupling halves to approximately 300° C (572° F) before installing on shafts. If not heated properly, the couplings will not fit on the hub properly.

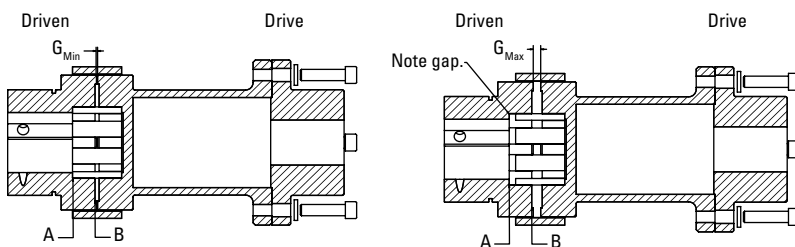

Fig. 8. Proper shaft-to-hub engagement.

Table 15. High-Performance Split Cover tightening torque

Coupling Series	Bolts	Tightening Torque
	mm	Nm ft-lbs
QF15HPCOVER	(4) M6 X 25MM	10.8 8
QF25HPCOVER	(4) M10 X 35MM	40.7 30
QF50HPCOVER	(4) M12 X 45MM	101.7 75
QF100HPCOVER	(4) M12 X 60MM	101.7 75
QF175HPCOVER	(4) M16 X 65MM	169.5 125
QF250HPCOVER	(4) M20 X 60MM	203.4 150
QF500HPCOVER	(4) M20 X 60MM	203.4 150

Revolutions Per Minute (RPM) and Balance

The QUICK FLEX coupling is machined on all surfaces and thus its dynamic balance is good. If the coupling is run at a high speed, it is important that the key used to attach the coupling hubs is the same length as the coupling hub. The set screws should also be changed to full length to fill the hole. Please refer to table 18 for maximum RPM ratings.

⚠ WARNING

Failure to observe the following warnings could create a risk of death or serious injury.

Contact with moving parts and/or rotating shafts poses a risk of serious injury. Proper guards in accordance with OSHA and American Society of Mechanical Engineers standards must be installed on all power transmission equipment. Power transmission equipment should not be started if proper guarding is not in place. Observe all required lock out/tag out procedures when servicing power transmission equipment.

Note: Shaft should penetrate to base of teeth and hubs should be set at G_Min. Otherwise, the coupling may not deliver maximum torque.

Single-Ended Spacer Coupling Installation

Table 16. QUICK FLEX Single-Ended Spacer Coupling Hub Gap (G) Dimensions

Coupling Series	High-Speed Cover		Low-Speed Split Cover		High-Speed Split Cover		High-Performance Split Cover	
	G _{Min}	G _{Max}	G _{Min}	G _{Max}	G _{Min}	G _{Max}	G _{Min}	G _{Max}
	mm in	mm in	mm in	mm in	mm in	mm in	mm in	mm in
QF5	1.60	2.34	N/A	N/A	N/A	N/A	N/A	N/A
	0.063	0.092						
QF15	2.27	2.64	2.01	2.51	2.27	2.64	2.27	2.64
	0.089	0.104	0.079	0.099	0.089	0.104	0.089	0.104
QF25	2.54	3.30	2.54	2.90	2.54	3.30	2.54	3.30
	0.100	0.130	0.100	0.114	0.100	0.130	0.100	0.130
QF50	2.67	4.60	1.52	2.29	2.67	4.60	2.67	3.56
	0.105	0.181	0.060	0.090	0.105	0.181	0.105	0.140
QF100	4.57	5.36	5.62	8.13	5.62	8.13	5.62	8.13
	0.180	0.211	0.221	0.320	0.221	0.320	0.221	0.320
QF175	6.43	7.44	6.43	7.98	6.43	7.98	6.43	7.98
	0.253	0.293	0.253	0.314	0.253	0.314	0.253	0.314
QF250	4.32	5.31	4.32	5.31	4.32	5.31	4.32	5.31
	0.170	0.209	0.170	0.209	0.170	0.209	0.170	0.209
QF500	4.98	6.35	N/A	N/A	4.98	8.51	4.98	8.51
	0.196	0.250			0.196	0.335	0.196	0.335
QF1000	6.02	8.86	N/A	N/A	6.02	8.86	N/A	N/A
	0.237	0.349			0.237	0.349		
QF1890	6.35	8.81	N/A	N/A	7.32	10.08	N/A	N/A
	0.250	0.347			0.288	0.397		
QF3150	4.24	7.85	N/A	N/A	4.24	7.85	N/A	N/A
	0.167	0.309			0.167	0.309		
QF10260	5.99	10.77	N/A	N/A	5.99	10.77	N/A	N/A
	0.236	0.424			0.236	0.424		

Single-Ended Spacer Coupling Installation

Table 17. QUICK FLEX Single-Ended Spacer Coupling Misalignment Tolerances

Coupling Series	Radial Misalignment Tolerance	Axial Misalignment Tolerance	Angular Misalignment Tolerance
	mm in	mm in	
QF5	0.51	1.98	2°
	0.020	0.078	
QF15	0.99	2.95	2°
	0.039	0.116	
QF25	0.99	2.95	2°
	0.039	0.116	
QF50	0.97	2.95	2°
	0.038	0.116	
QF100	1.47	3.96	2°
	0.058	0.156	
QF175	1.47	4.45	1.3°
	0.058	0.175	
QF250	1.47	5.94	1.3°
	0.058	0.234	
QF500	1.47	5.94	1°
	0.058	0.234	
QF1000	1.47	5.94	1°
	0.058	0.234	
QF1890	1.47	7.92	1°
	0.058	0.312	
QF3150	1.98	7.92	1°
	0.078	0.312	
QF10260	1.98	7.92	1°
	0.078	0.312	

Table 18. QUICK FLEX SINGLE-ENDED SPACER COUPLING Maximum RPM Ratings

Coupling Series	High-Speed Cover	Low-Speed Split Cover	High-Speed Split Cover	High-Performance Split Cover
	RPM	RPM	RPM	RPM
QF5	12000	N/A	N/A	N/A
QF15	9000	400	9000	9000
QF25	7000	375	7000	7000
QF50	6000	350	6000	6000
QF100	4800	300	4800	4800
QF175	4200	250	4200	4200
QF250	3800	200	3800	3800
QF500	3400	N/A	3400	3400
QF1000	3000	N/A	3000	3000
QF1890	2400	N/A	2400	2400
QF3150	2000	N/A	2000	2000
QF10260	1200	N/A	1200	1200

Note: ■ Maximum RPM ratings are for off-the-shelf QUICK FLEX couplings. If your application requires higher RPM ratings, the couplings should be dynamically balanced.

Double-Ended Spacer Coupling Installation

Please complete the following steps to install QUICK FLEX double-ended spacer couplings.

You should have the following pieces before starting the job:

- Two hubs
- One spacer body
- Two inserts
- Two covers with included hardware

Note: It is critical to identify what style cover you are using, as this will change the hardware included, as well as the installation procedure. A mismatch between the coupling and the application may result in less than optimal performance.

There are four types of covers (fig. 9):

- **High-speed cover:** QF5 through QF175 use a standard snap ring to secure cover in place. QF250 and larger use eight bolts with lock washers.
- **Low-speed split cover:** This cover is free-floating and is located outside the shoulders of the two hubs. All sizes come with four bolts for securing the two halves together around the insert.
- **High-speed split cover:** This cover will be supplied in four pieces to fit over the spacer body. QF15 through QF250 use eight bolts around the rim to secure the two halves together, QF500 through QF1890 use 16 bolts, and QF3150 and larger use 20 bolts. QF250 and larger use eight bolts with lock washers to secure the cover to each hub.
- **High-performance split cover:** This cover is free-floating and is located on the insert with an internal radial groove. All sizes come with four socket-head cap screws for securing the two halves together around the insert.

Installation

1. Check the bore size of the coupling halves and the shafts. Ensure that they are the correct bore size to fit the application.
2. If the coupling does not fit easily, clean and deburr the shafts.
3. Identify cover style:
 - a. **If using high-speed covers QF5 through QF175,** slide one snap ring down each shaft, then slide one cover onto each shaft with the larger opening facing the shaft separation. For QF250 and larger, slide one cover onto each shaft with the larger opening facing the shaft separation.
 - b. **If using low-speed or high-performance split covers,** leave covers aside and continue to step 4.
 - c. **If using high-speed split covers, QF250 and larger,** use bolts and washers to secure in place. In some instances, one or both vertically split pieces cover halves will also be split horizontally. The horizontally split half should be placed on the spacer body side. If both halves are split, then splits should be aligned 90 degrees from each other when bolted together. Do not bolt to coupling hub until installation is complete.

Note: Standard hubs are supplied with a clearance fit and should slide onto the shaft without excessive force. If the hubs have been ordered with interference fit, then heat the coupling halves to approximately 300° C (572° F) before installing on shafts. If not heated properly, the couplings will not fit on the hub properly.

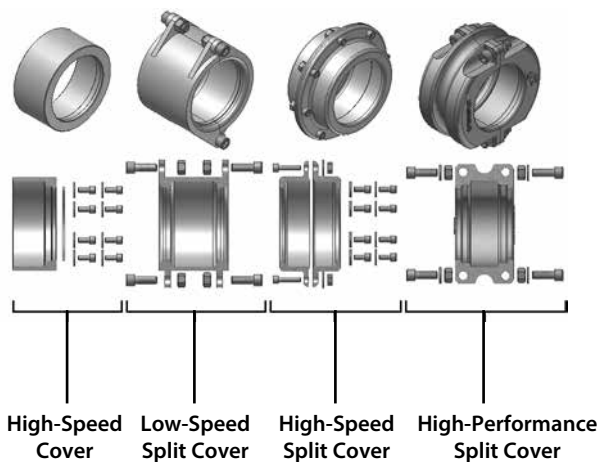

Fig. 9. QUICK FLEX cover types and included hardware.

⚠ WARNING

Failure to observe the following warnings could create a risk of death or serious injury.

Contact with moving parts and/or rotating shafts poses a risk of serious injury. Proper guards in accordance with OSHA and American Society of Mechanical Engineers standards must be installed on all power transmission equipment. Power transmission equipment should not be started if proper guarding is not in place. Observe all required lock out/tag out procedures when servicing power transmission equipment.

Double-Ended Spacer Coupling Installation

4. Install the hubs. They should be mounted so the end of the shaft is flush with surface "A" as shown in fig. 10.
5. Install the spacer body and inserts. Slide all three components (spacer body and two inserts) tight to one side and check the gap from the insert face to hub flange face shown as surface "A" in fig. 10. This should not exceed $[(2 \times G_{Max}) - (2 \times G_{Min})]$ using the appropriate minimum hub gap (G_{Min}) and the maximum hub gap (G_{Max}) from table 20.

If this gap exceeds your calculation, adjust one or both hubs to set within specs, paying attention not to have the shaft end extend past surface "B" as shown in fig. 10.

6. Tighten both hubs securely to the shafts using the set screws.
7. Check coupling for misalignment (table 21) and align as necessary.
8. Install the cover:
 - a. **High-speed cover:** Slide the cover over the coupling hub and insert until fully rested against the shoulder of the coupling hub. Use the included hardware to secure the cover.
 - b. **Low-speed or high-performance split cover:** Place each half over the insert and secure using the four bolt/washer/nut hardware combinations supplied. For the high-performance split cover bolt tightening torque ratings, see table 19.
 - c. **High-speed split cover:** Match the four pieces into two complete cover halves using the flange face detail to distinguish the two halves. For QF250 and larger, make sure the cover half with the eight holes for mounting to the coupling hub is on the coupling hub side, not the spacer side. Bolt the four pieces together using the supplied hardware, ensuring the splits in each half are rotated 90 degrees relative to each other. Install bolts to secure the cover to the coupling hub.

Table 19. High-Performance Split Cover Tightening Torque

Coupling Series	Bolts	Tightening Torque
	mm	Nm ft-lbs
QF15HPCOVER	(4) M6 X 25MM	10.8 8
QF25HPCOVER	(4) M10 X 35MM	40.7 30
QF50HPCOVER	(4) M12 X 45MM	101.7 75
QF100HPCOVER	(4) M12 X 60MM	101.7 75
QF175HPCOVER	(4) M16 X 65MM	169.5 125
QF250HPCOVER	(4) M20 X 60MM	203.4 150
QF500HPCOVER	(4) M20 X 60MM	203.4 150

Revolutions Per Minute (RPM) and Balance

The QUICK FLEX coupling is machined on all surfaces and thus its dynamic balance is good. If the coupling is run at a high speed, it is important that the key used to attach the coupling hubs is the same length as the coupling hub. The set screws should also be changed to full length to fill the hole. Please refer to table 22 for maximum RPM ratings.

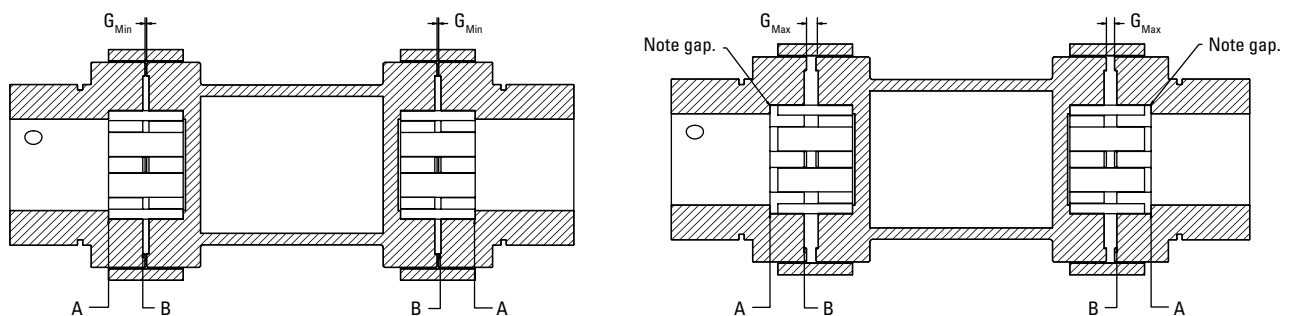

Fig. 10. Proper shaft-to-hub engagement.

Double-Ended Spacer Coupling Installation

Table 20. QUICK FLEX Double-Ended Spacer Coupling Hub Gap (G) Dimensions

Coupling Series	High-Speed Cover		Low-Speed Split Cover		High-Speed Split Cover		High-Performance Split Cover	
	G _{Min}	G _{Max}	G _{Min}	G _{Max}	G _{Min}	G _{Max}	G _{Min}	G _{Max}
	mm in	mm in	mm in	mm in	mm in	mm in	mm in	mm in
QF5	1.60	2.34	N/A	N/A	N/A	N/A	N/A	N/A
	0.063	0.092						
QF15	2.27	2.64	2.01	2.51	2.27	2.64	2.27	2.64
	0.089	0.104	0.079	0.099	0.089	0.104	0.089	0.104
QF25	2.54	3.30	2.54	2.90	2.54	3.30	2.54	3.30
	0.100	0.130	0.100	0.114	0.100	0.130	0.100	0.130
QF50	2.67	4.60	1.52	2.29	2.67	4.60	2.67	3.56
	0.105	0.181	0.060	0.090	0.105	0.181	0.105	0.140
QF100	4.57	5.36	5.62	8.13	5.62	8.13	5.62	8.13
	0.180	0.211	0.221	0.320	0.221	0.320	0.221	0.320
QF175	6.43	7.44	6.43	7.98	6.43	7.98	6.43	7.98
	0.253	0.293	0.253	0.314	0.253	0.314	0.253	0.314
QF250	4.32	5.31	4.32	5.31	4.32	5.31	4.32	5.31
	0.170	0.209	0.170	0.209	0.170	0.209	0.170	0.209
QF500	4.98	6.35	N/A	N/A	4.98	8.51	4.98	8.51
	0.196	0.250			0.196	0.335	0.196	0.335
QF1000	6.02	8.86	N/A	N/A	6.02	8.86	N/A	N/A
	0.237	0.349			0.237	0.349		
QF1890	6.35	8.81	N/A	N/A	7.32	10.08	N/A	N/A
	0.250	0.347			0.288	0.397		
QF3150	4.24	7.85	N/A	N/A	4.24	7.85	N/A	N/A
	0.167	0.309			0.167	0.309		
QF10260	5.99	10.77	N/A	N/A	5.99	10.77	N/A	N/A
	0.236	0.424			0.236	0.424		

Double-Ended Spacer Coupling Installation

Table 21. QUICK FLEX Double-Ended Spacer Coupling Misalignment Tolerances

Coupling Series	Radial Misalignment Tolerance	Axial Misalignment Tolerance	Angular Misalignment Tolerance
	mm in	mm in	
QF5	1.02	3.96	4°
	0.040	0.156	
QF15	1.98	5.89	4°
	0.078	0.232	
QF25	1.98	5.89	4°
	0.078	0.232	
QF50	2.95	5.89	4°
	0.116	0.232	
QF100	2.95	7.93	4°
	0.116	0.312	
QF175	2.95	8.89	2.6°
	0.116	0.350	
QF250	2.95	11.89	2.6°
	0.116	0.468	
QF500	2.95	11.89	2°
	0.116	0.468	
QF1000	2.95	11.89	2°
	0.116	0.468	
QF1890	2.95	15.85	2°
	0.116	0.624	
QF3150	3.96	15.85	2°
	0.156	0.624	
QF10260	3.96	15.85	2°
	0.156	0.624	

Table 22. QUICK FLEX Double-Ended Spacer Maximum RPM Ratings

Coupling Series	High-Speed Cover	Low-Speed Split Cover	High-Speed Split Cover	High-Performance Split Cover
	RPM	RPM	RPM	RPM
QF5	N/A	N/A	N/A	N/A
QF15	4500	400	4500	4500
QF25	4500	375	4500	4500
QF50	4500	350	4500	4500
QF100	4500	300	4500	4500
QF175	3600	250	3600	3600
QF250	3200	200	3200	3200
QF500	3000	N/A	3000	3000
QF1000	2500	N/A	2500	2500
QF1890	2100	N/A	2100	2100
QF3150	1800	N/A	1800	1800
QF10260	1000	N/A	1100	1000

Note: ■ Maximum RPM ratings are for off-the-shelf QUICK FLEX couplings. If your application requires higher RPM ratings, the couplings should be dynamically balanced.

Nomenclature

Standard Couplings

Standard Coupling Nomenclature

A complete standard coupling unit consists of:

- Two hubs.
- One insert (see page 34).
- One cover (see pages 35-37).

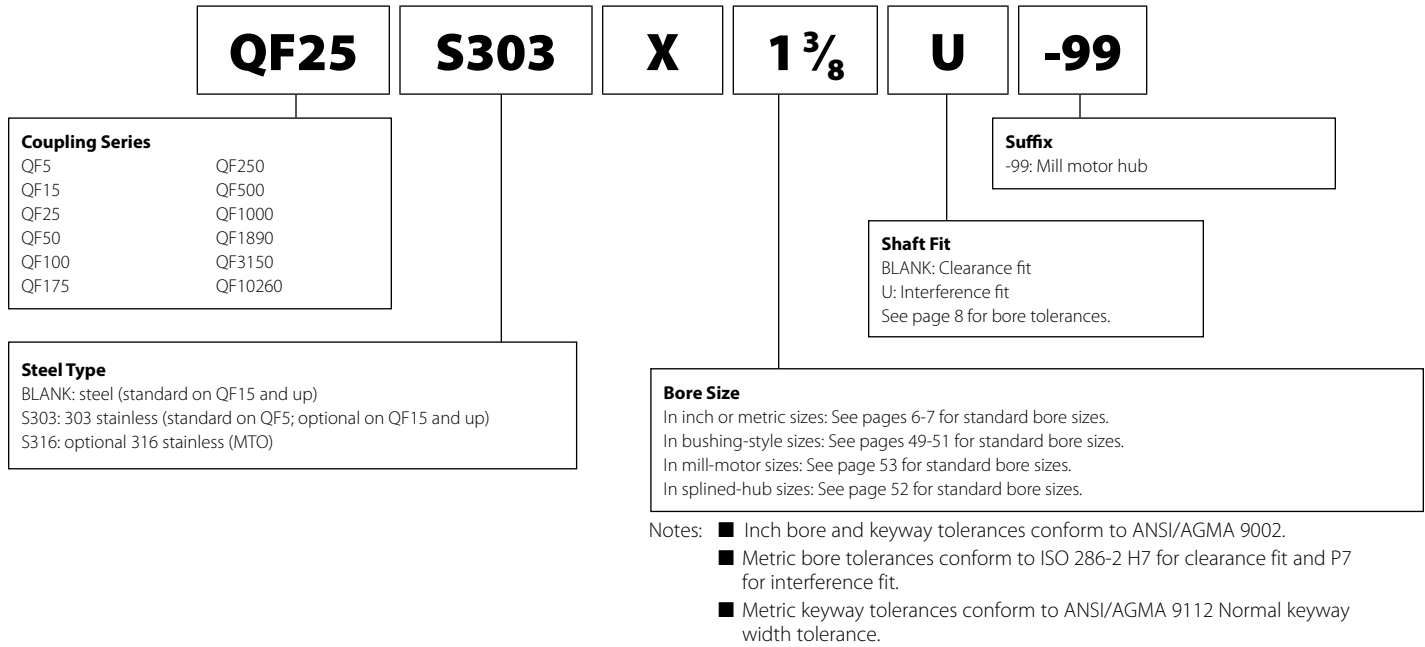

Fig. 11. Hubs.

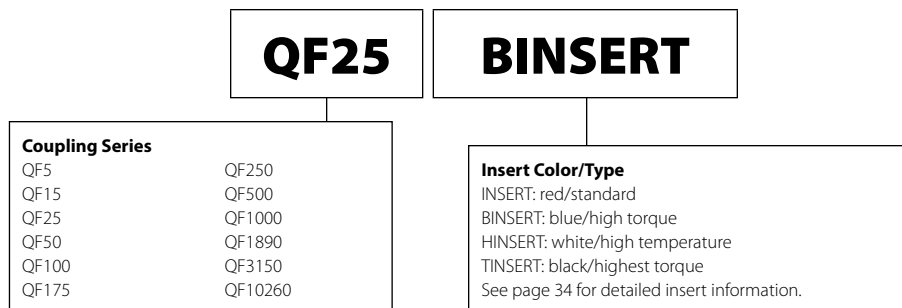

Fig.12. Inserts.

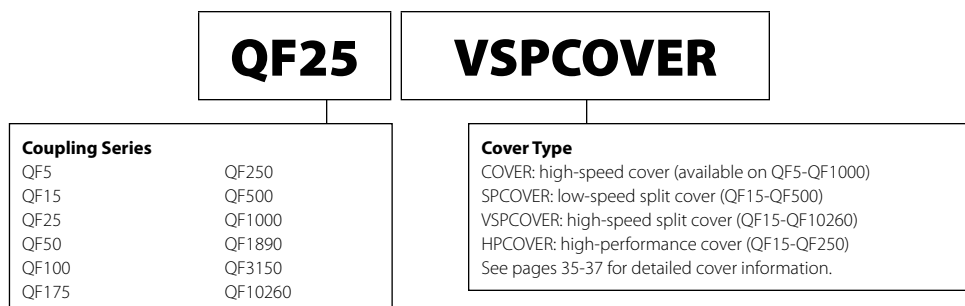

Fig. 13. Covers.

Nomenclature Spacer Couplings

Spacer Coupling Nomenclature

A complete *single-ended* spacer coupling unit consists of:

- One standard hub (see page 32).
- One flanged spacer hub.
- One single-ended spacer body.
- One insert (see page 34).
- One cover (see pages 35-37).

A complete *double-ended* spacer coupling unit consists of:

- Two standard hubs (see page 32).
- One double-ended spacer body.
- Two inserts (see page 34).
- Two covers (see pages 35-37).

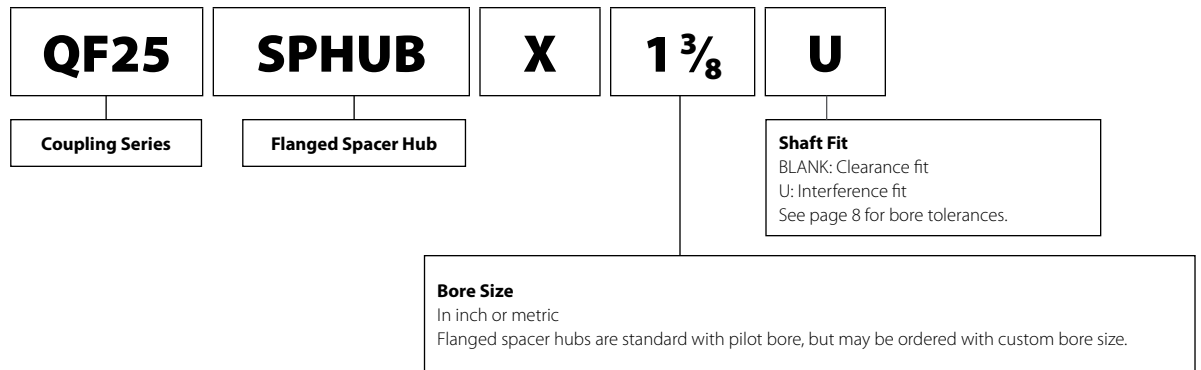

- Notes:
- Inch bore and keyway tolerances conform to ANSI/AGMA 9002.
 - Metric bore tolerances conform to ISO 286-2 H7 for clearance fit and P7 for interference fit.
 - Metric keyway tolerances conform to ANSI/AGMA 9112 Normal keyway width tolerance.

Fig. 14. Flanged spacer hubs.

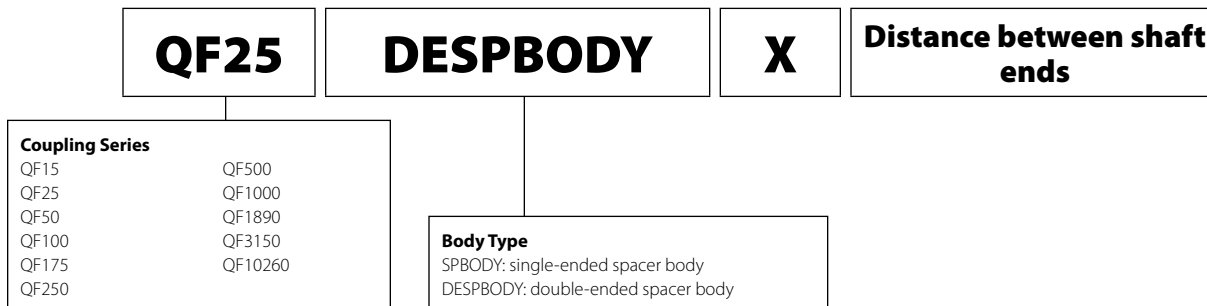

Fig. 15. Flanged spacer bodies.

Inserts and Covers

Coupling Inserts

Inserts and Covers

QUICK FLEX Coupling Inserts

QUICK FLEX flexible urethane coupling inserts are resistant to most chemicals (see page 18-19) and available in four materials for varying temperature and torque needs:

QUICK FLEX red insert (standard)

The standard QUICK FLEX red insert is made from a relatively soft urethane compound. This insert is well suited for a wide range of applications. The standard insert excels in vibration dampening and cushioning of shock loads and is best for reversing applications or applications with quick starting and stopping of high-inertial loads. This insert offers an operational temperature range of -50° C to 100° C (-60° F to 212° F) with a 48D durometer.

QUICK FLEX blue insert (high torque)

The QUICK FLEX blue insert is made from a relatively stiff urethane compound. This insert is well suited for applications with moderate to high torque. QUICK FLEX couplings with the blue insert deliver high torque while maintaining a degree of torsional softness and the ability to dampen vibration. They are excellent replacements for gear, grid or chain-style couplings. This insert offers an operational temperature range of -50° C to 100° C (-60° F to 212° F) with a 60D durometer.

QUICK FLEX black insert (highest torque)

The QUICK FLEX black insert offers the highest torque ratings of any of our inserts. This insert is well suited for very high torque applications, and QUICK FLEX couplings with a black insert are excellent replacements for gear-style couplings. This insert offers an operational temperature range of -50° C to 100° C (-60° F to 212° F) with a 68D durometer. When using a high-speed cover, the use of a black insert is not recommended. In an application where high torque is present, use a split cover option.

QUICK FLEX white insert (high temperature)

The QUICK FLEX white insert is made of a heat-resistant urethane compound for use in applications where heat is a concern. This insert offers an operational temperature range of -50° C to 177° C (-60° F to 350° F) with a 60D durometer.

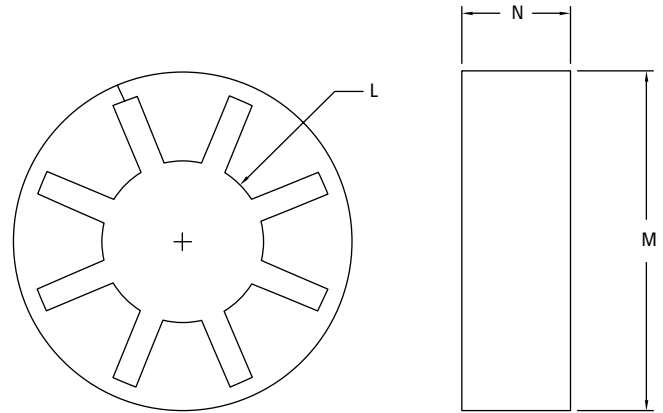

Fig. 16. QUICK FLEX insert.

Table 23. QUICK FLEX Insert Dimensions

Coupling Series	L	M	N	Wt.
	mm in	mm in	mm in	kg lbs
QF5	31.2	56.6	16.0	0.1
	1.23	2.23	0.63	0.2
QF15	42.2	72.6	21.6	0.1
	1.66	2.86	0.85	0.2
QF25	54.9	96.5	31.2	0.1
	2.16	3.80	1.23	0.2
QF50	61.2	128.3	41.7	0.4
	2.41	5.05	1.64	0.9
QF100	77.5	163.6	51.3	0.7
	3.05	6.44	2.02	1.5
QF175	99.1	187.2	59.7	0.9
	3.90	7.37	2.35	2.0
QF250	104.9	208.3	58.9	1.4
	4.13	8.20	2.32	3.0
QF500	114.6	253.5	66.8	2.3
	4.51	9.98	2.63	5.0
QF1000	157.2	287.0	75.2	2.7
	6.19	11.30	2.96	6.0
QF1890	193.0	345.7	82.3	4.1
	7.60	13.61	3.24	9.0
QF3150	232.4	404.6	93.2	5.9
	9.15	15.93	3.67	13.0
QF10260	285.8	483.6	137.9	14.1
	11.25	19.04	5.43	31.1

Inserts and Covers

High-Speed Cover

QUICK FLEX High-Speed Cover

QUICK FLEX high-speed covers are designed for applications where low torque and/or high speed is present.

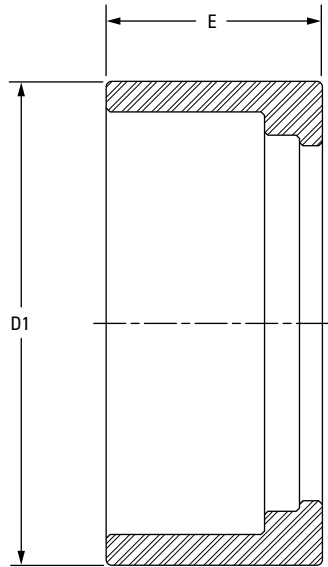

Fig. 17. High-Speed cover.

Table 24. QUICK FLEX High-Speed Cover Dimensions

Cover Part No.	Maximum RPM	D1		E	
		mm	in	mm	in
QF5COVER	12000	63.2	24.1		
		2.49	0.95		
QF15COVER	9000	80.3	34.3		
		3.16	1.35		
QF25COVER	7000	106.9	49.5		
		4.21	1.95		
QF50COVER	6000	139.2	60.5		
		5.48	2.38		
QF100COVER	4800	177.8	75.2		
		7.00	2.96		
QF175COVER	4200	203.2	83.1		
		8.00	3.27		
QF250COVER	3800	225.6	88.9		
		8.88	3.50		
QF500COVER	3400	273.6	102.9		
		10.77	4.05		
QF1000COVER	3000	308.1	124.0		
		12.13	4.88		
QF1890COVER	2400	365.3	127.0		
		14.38	5.00		
QF3150COVER	2000	425.5	139.7		
		16.75	5.50		
QF10260COVER	1800	510.5	201.7		
		20.10	7.94		

Inserts and Covers High-Speed Split Cover

QUICK FLEX High-Speed Split Cover

QUICK FLEX High-Speed split covers are ideal in applications where high torque is combined with higher speeds while minimizing axial loading.

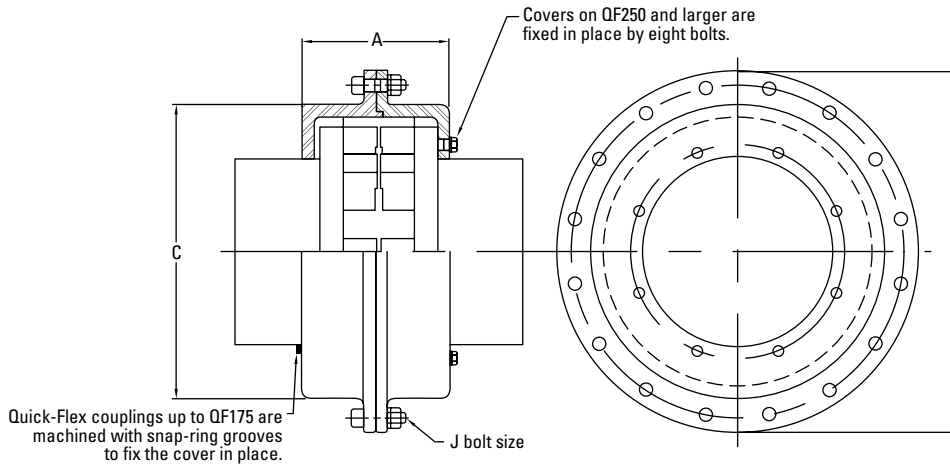

Fig. 18. High-Speed split cover.

Table 25. QUICK FLEX High-Speed Split Cover Dimensions

Cover Part No.	Maximum RPM	A	B	C	J
		mm in	mm in	mm in	mm
QF15VSPCOVER	9000	45.2	119.4	85.9	(8) M6 X 20MM
		1.78	4.70	3.38	
QF25VSPCOVER	7000	63.5	142.7	107.7	(8) M6 X 20MM
		2.50	5.62	4.24	
QF50VSPCOVER	6000	87.9	193.6	141.7	(8) M10 X 20MM
		3.46	7.62	5.58	
QF100VSPCOVER	4800	118.4	227.3	181.9	(8) M10 X 35MM
		4.66	8.95	7.16	
QF175VSPCOVER	4200	124.0	250.2	204.2	(8) M10 X 35MM
		4.88	9.85	8.04	
QF250VSPCOVER	3800	118.6	266.7	225.0	(8) M10 X 35MM & (8) M10 X 35MM
		4.67	10.50	8.86	
QF500VSPCOVER	3400	149.4	342.9	273.1	(12) M12 X 45MM & (8) M10 X 35MM
		5.88	13.50	10.75	
QF1000VSPCOVER	3000	157.7	387.4	314.5	(16) M12 X 45MM & (8) M10 X 35MM
		6.21	15.25	12.38	
QF1890VSPCOVER	2800	185.9	450.9	374.7	(16) M12 X 50MM & (8) M12 X 40MM
		7.32	17.75	14.75	
QF3150VSPCOVER	2000	188.5	497.6	431.3	(20) M12 X 45MM & (8) M20 X 45MM
		7.42	19.59	16.98	
QF10260VSPCOVER	1200	275.6	619.3	523.2	(20) M12 X 65MM & (8) M12 X 40MM
		10.85	24.38	20.60	

Note: ■ Available split horizontally upon request specified as HVSPCOVER.

Inserts and Covers

High-Speed Split Cover

Standard Couplings

QUICK FLEX Aluminum High-Performance (HP) Cover

QUICK FLEX aluminum high-performance covers are designed to minimize axial loading in all applications including high or low torque and high or low speed.

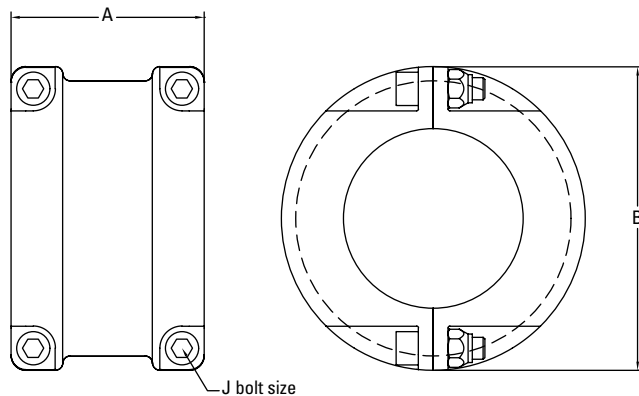

Fig. 19. Aluminum High-Performance cover.

Table 26. QUICK FLEX Aluminum High-Performance (HP) Cover Dimensions

Cover Part No.	Maximum RPM	A	B	J
		mm in	mm in	mm
QF15HPCOVER	9000	49.0	101.3	(4) M6 X 25MM
		1.93	3.99	
QF25HPCOVER	7000	66.3	135.6	(4) M10 X 35MM
		2.61	5.32	
QF50HPCOVER	6000	76.7	185.0	(4) M12 X 45MM
		3.02	7.28	
QF100HPCOVER	4800	151.4	197.1	(4) M12 X 60MM
		5.96	7.76	
QF175HPCOVER	4200	156.7	216.4	(4) M16 X 65MM
		6.17	8.52	
QF250HPCOVER	3800	166.1	261.4	(4) M20 X 60MM
		6.54	10.29	
QF500HPCOVER	3400	201.2	305.3	(4) M20 X 60MM
		7.92	12.02	

QUICK FLEX Low-Speed Split Cover

By minimizing axial loading, QUICK FLEX Low-Speed split covers excel in applications where there is a high amount of torque and low speeds.

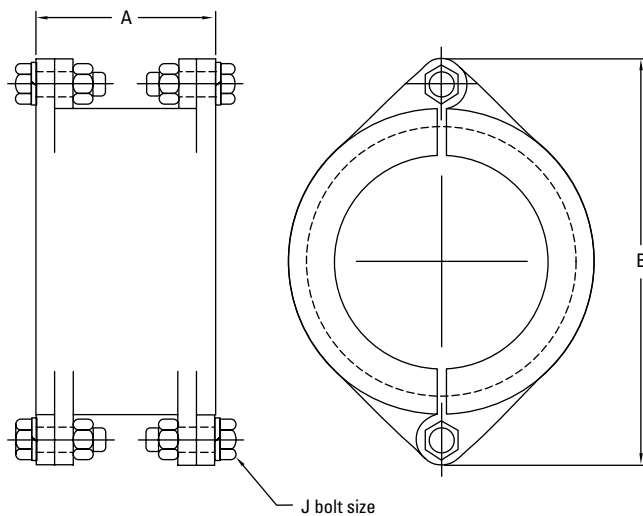

Fig. 20. Low-Speed split cover.

Table 27. QUICK FLEX Low-Speed Split-Cover Dimensions

Cover Part No.	Maximum RPM	A	B	J
		mm in	mm in	mm
QF15SPCOVER	400	50.8	124.2	(4) M8 X 25MM
		2.00	4.89	
QF25SPCOVER	375	78.0	145.0	(4) M10 X 35MM
		3.07	5.71	
QF50SPCOVER	350	87.9	192.5	(4) M12 X 35MM
		3.46	7.58	
QF100SPCOVER	300	118.4	231.9	(4) M12 X 40MM
		4.66	9.13	
QF175SPCOVER	250	124.0	282.4	(4) M16 X 50MM
		4.88	11.12	
QF250SPCOVER	200	130.3	304.8	(4) M20 X 50MM
		5.13	12.00	

Standard Couplings With High-Speed Cover

Standard Coupling with High-Speed Cover

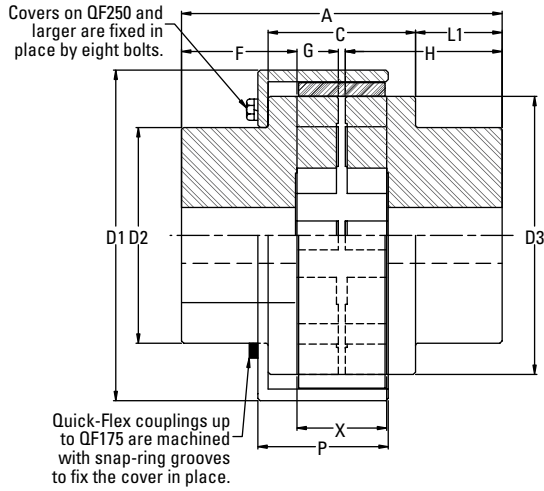

Fig. 21. Standard coupling with high-speed cover.

Table 28. QUICK FLEX Insert Continuous Torque Ratings

Coupling Series	Red	Blue	White	Black ¹
	Nm in-lbs	Nm in-lbs	Nm in-lbs	Nm in-lbs
QF5	43	93	93	N/A
	377	819	819	
QF15	120	234	234	N/A
	1059	2075	2075	
QF25	387	730	730	N/A
	3426	6461	6461	
QF50	798	1582	1582	N/A
	7066	14002	14002	
QF100	1602	3177	3177	N/A
	14178	28115	28115	
QF175	2780	5325	5325	N/A
	24602	47123	47123	
QF250	3513	6975	6975	N/A
	31091	61726	61726	
QF500	6790	13051	13051	N/A
	60091	115497	115497	
QF1000	9601	18418	18418	N/A
	84966	162997	162997	
QF1890	10740	20409	20409	N/A
	95061	180639	180639	
QF3150	11880	22401	22401	N/A
	105135	198252	198252	
QF10260	23748	44736	44736	N/A
	210173	395913	395913	

Note: ■ 1 indicates: When using a high-speed cover, the use of a black insert is not recommended. In an application where high torque is present, use a Split Cover option. Contact your Lovejoy application engineer for maximum shaft distance.

Table 29. QUICK FLEX Standard Coupling with High-Speed Cover Dimensions

Coupling Series	Pilot-Bore Diameter	Maximum Bore Size		Maximum RPM	Continuous Torque ¹	A	C	D1	D2	D3	F	G _{Min}	G _{Max}	H	L1	P	X	Wt. ²
		Square Key	Shallow Key															kg lbs
		in	mm in															mm in
QF5	-	25	-	12000	93	71.1	26.2	63.2	50.8	52.6	27.4	2.47	2.30	34.8	22.4	24.1	16.8	1.8
		1 ¼	-	819	2.80	1.03	2.49	2.00	2.07	1.08	0.097	0.092	1.37	0.88	0.95	0.66	4	
QF15	17/32	40	-	9000	234	89.9	32.5	80.3	58.7	64.5	34.0	1.71	2.80	44.5	29.0	34.3	22.4	2.3
		1 ⅝	-	2075	3.54	1.28	3.16	2.31	2.55	1.34	0.067	0.110	1.75	1.14	1.35	0.88	5	
QF25	5/8	50	-	7000	730	123.4	50.8	106.9	81.0	85.6	46.0	2.83	5.20	60.7	36.1	49.5	30.7	5.0
		2 ⅝	-	6461	4.86	2.00	4.21	3.19	3.37	1.81	0.111	0.205	2.39	1.42	1.95	1.21	11	
QF50	23/32	60	-	6000	1582	151.4	61.5	139.2	89.4	114.0	54.9	1.81	5.30	75.2	45.2	60.5	42.2	6.8
		2 ¾	-	14002	5.96	2.42	5.48	3.52	4.49	2.16	0.071	0.208	2.96	1.78	2.38	1.66	15	
QF100	15/16	75	-	4800	3177	179.6	88.4	177.8	108.0	150.4	62.5	4.35	7.40	86.4	44.7	75.2	55.6	16.8
		3	-	28115	7.07	3.48	7.00	4.25	5.92	2.46	0.171	0.290	3.40	1.76	2.96	2.19	37	
QF175	1	95	-	4200	5325	195.3	93.2	203.2	139.7	171.5	67.8	6.41	5.30	95.3	50.8	83.1	65.2	25.9
		3 ⅝	-	47123	7.69	3.67	8.00	5.50	6.75	2.67	0.253	0.208	3.75	2.00	3.27	2.45	57	
QF250	1 ½	105	-	3800	6975	216.2	100.6	225.6	147.1	190.0	78.7	4.13	5.80	107.1	59.2	88.9	63.2	32.3
		4 ⅝	-	61726	8.51	3.96	8.88	5.79	7.48	3.10	0.163	0.228	4.21	2.33	3.50	2.49	71	
QF500	1 ⅞	115	-	3400	13051	257.3	118.6	273.6	177.8	235.0	95.3	4.89	6.40	127.0	69.9	102.9	69.9	57.3
		4 ½	-	115497	10.13	4.67	10.77	7.00	9.25	3.75	0.193	0.252	5.00	2.75	4.05	2.75	126	
QF1000	1 ⅞	140	-	3000	18418	309.6	126.7	308.1	198.4	266.7	116.8	5.65	9.86	152.4	91.4	124.0	77.2	98.2
		5 ½	6 ⅝	162997	12.19	4.99	12.13	7.81	10.50	4.60	0.223	0.388	6.00	3.60	4.88	3.04	216	
QF1890	2 ½	175	-	2400	20409	373.4	150.1	365.3	241.3	325.1	145.8	6.62	7.06	184.4	113.0	127.0	85.1	181.8
		6 ½	7 ½	180639	14.70	5.91	14.38	9.50	12.80	5.74	0.261	0.278	7.26	4.45	5.00	3.35	400	
QF3150	2 ½	205	-	2000	22401	408.4	159.8	425.5	279.4	383.3	157.0	3.37	7.75	202.7	127.0	139.7	101.3	241.8
		6 ½	9	198252	16.08	6.29	16.75	11.00	15.09	6.18	0.133	0.305	7.98	5.00	5.50	3.99	532	
QF10260	2 ½	280	-	1800	44736	508.3	231.1	510.5	381.0	450.9	183.4	4.64	12.83	251.0	138.4	201.7	144.3	507.3
		6 ½	11 ¼	395913	20.01	9.10	20.10	15.00	17.75	7.22	0.183	0.505	9.88	5.45	7.94	5.68	1116	

Notes: ■ 1 indicates: When used with blue insert. See pages 10-11 for complete torque ratings.

■ 2 indicates: Weights shown are approximate weights of complete coupling assemblies including two pilot-bore hubs, cover and insert.

Standard Couplings With High-Speed Cover

Standard Coupling with High-Speed Split Cover

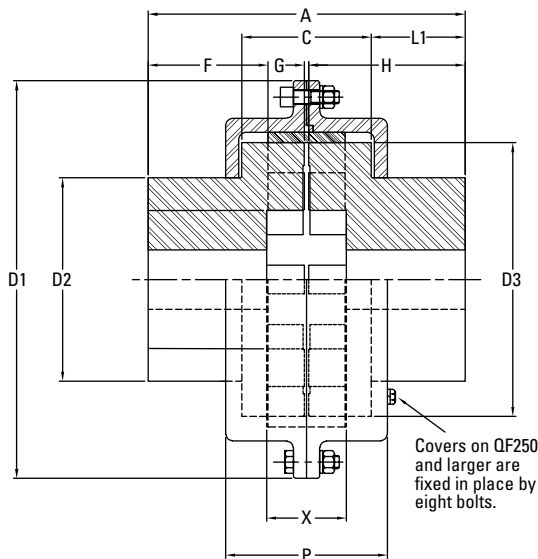

Fig. 22. Standard coupling with high-speed split cover.

Table 30. QUICK FLEX Insert Continuous Torque Ratings

Coupling Series	Red	Blue	White	Black
	Nm in-lbs	Nm in-lbs	Nm in-lbs	Nm in-lbs
QF15	150	293	293	452
	1324	2594	2594	4001
QF25	484	913	913	1407
	4283	8077	8077	12449
QF50	998	1978	1978	2992
	8833	17502	17502	26479
QF100	2003	3971	3971	6061
	17723	35144	35144	53642
QF175	3475	6656	6656	9973
	30753	58903	58903	88257
QF250	4391	8718	8718	13438
	38864	77158	77158	118930
QF500	8487	16313	16313	24794
	75114	144372	144372	219429
QF1000	12001	23022	23022	35081
	106208	203746	203746	310466
QF1890	19869	38937	38937	62597
	175840	344594	344594	553982
QF3150	33942	64004	64004	98434
	300387	566434	566434	871139
QF10260	67852	127817	127817	188794
	600494	1131179	1131179	1670826

Table 31. QUICK FLEX Standard Coupling with High-Speed Split Cover Dimensions

Coupling Series	Pilot-Bore Diameter	Maximum Bore Size		Max. RPM	Continuous Torque ¹	A	C	D1	D2	D3	F	G _{Min}	G _{Max}	H	L1	P	X	Wt. ²
		Square Key	Shallow Key															
		in	mm															
QF15	17/32	40	-	9000	452	89.9	32.5	119.4	58.7	64.8	34.0	1.71	3.20	44.5	29.0	45.2	22.4	3.2
		1 5/8	-		4001	3.54	1.28	4.70	2.31	2.55	1.34	0.067	0.126	1.75	1.14	1.78	0.88	7
QF25	5/8	50	-	7000	1407	123.4	50.8	142.7	81.0	85.6	46.0	2.83	3.60	60.7	36.1	63.5	30.7	5.9
		2 1/8	-		12449	4.86	2.00	5.62	3.19	3.37	1.81	0.111	0.140	2.39	1.42	2.5	1.21	13
QF50	23/32	60	-	6000	2992	151.4	61.5	193.5	89.4	114.0	54.9	1.81	5.60	75.2	45.2	87.9	42.2	9.1
		2 3/8	-		26479	5.96	2.42	7.62	3.52	4.49	2.16	0.071	0.220	2.96	1.78	3.46	1.66	20
QF100	15/16	75	-	4800	6061	179.6	88.4	227.3	108.0	150.4	62.5	4.35	9.70	86.4	44.7	118.4	55.6	21.3
		3	-		53642	7.07	3.48	8.95	4.25	5.92	2.46	0.171	0.380	3.40	1.76	4.66	2.19	47
QF175	1	95	-	4200	9973	195.3	93.2	250.2	139.7	171.5	67.8	6.41	8.80	95.3	50.8	124.0	62.2	29.5
		3 7/8	-		88257	7.69	3.67	9.85	5.50	6.75	2.67	0.253	0.348	3.75	2.00	4.88	2.45	65
QF250	1 1/2	105	-	3800	13438	216.2	100.6	266.7	147.1	190.0	78.7	4.13	6.60	106.9	59.2	118.6	63.2	36.7
		4 1/8	-		118930	8.51	3.96	10.50	5.79	7.48	3.10	0.163	0.258	4.21	2.33	4.67	2.49	80
QF500	1 7/8	115	-	3400	24794	257.3	118.6	342.9	177.8	235.0	95.3	4.89	9.50	127.0	69.9	201.2	69.9	61.8
		4 1/2	-		219429	10.13	4.67	13.50	7.00	9.25	3.75	0.193	0.375	5.00	2.75	7.92	2.75	136
QF1000	1 7/8	140	-	3000	35081	309.6	126.7	387.4	198.4	266.7	116.8	5.65	10.40	152.4	91.4	157.7	77.2	102.5
		5 1/8	6 3/16		310466	12.19	4.99	15.25	7.81	10.50	4.60	0.223	0.410	6.00	3.60	6.21	3.04	226
QF1890	2 1/2	175	-	2400	62597	373.4	150.1	450.9	241.3	325.1	145.8	6.62	11.50	184.4	113.0	185.9	85.1	186.0
		6 1/2	7 1/2		553982	14.70	5.91	17.75	9.50	12.80	5.74	0.261	0.454	7.26	4.45	7.32	3.35	410
QF3150	2 1/2	205	-	2000	98434	408.4	159.8	497.6	279.4	383.3	157.0	3.37	9.652	202.7	127.0	188.5	101.3	245.9
		6 1/2	9		871139	16.08	6.29	19.56	11.00	15.09	6.18	0.133	0.380	7.98	5.00	7.42	3.99	542
QF10260	2 1/2	280	-	1200	188794	508.3	231.1	619.3	381.0	450.9	183.4	4.64	12.50	251.0	138.4	275.6	144.3	515.3
		6 1/2	11 1/4		1670826	20.01	9.10	24.38	15.00	17.75	7.22	0.183	0.492	9.88	5.45	10.85	5.68	1136

Notes: ■ 1 indicates: When used with black insert. See pages 12-13 for complete torque ratings.

■ 2 indicates: Weights shown are approximate weights of complete coupling assemblies including two pilot-bore hubs, cover and insert.

Standard Couplings

With Aluminum High-Performance (HP) Cover

Standard Coupling with Aluminum High-Performance (HP) Cover

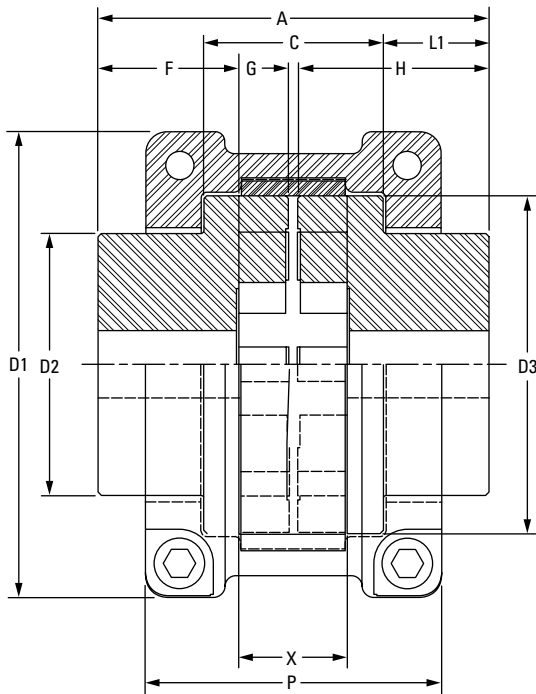

Fig. 23. Standard coupling with aluminum high-performance cover.

Table 32. QUICK FLEX Insert Continuous Torque Ratings

Coupling Series	Red	Blue	White	Black
	Nm in-lbs	Nm in-lbs	Nm in-lbs	Nm in-lbs
QF15	150	293	293	452
	1324	2594	2594	4001
QF25	484	913	913	1407
	4283	8077	8077	12449
QF50	998	1978	1978	2992
	8833	17502	17502	26479
QF100	2003	3971	3971	6061
	17723	35144	35144	53642
QF175	3475	6656	6656	9973
	30753	58903	58903	88257
QF250	4391	8718	8718	13438
	38864	77158	77158	118930
QF500	8487	16313	16313	24794
	75114	144372	144372	219429

Table 33. QUICK FLEX Standard Coupling with Aluminum High-Performance (HP) Cover Dimensions

Coupling Series	Pilot-Bore Diameter	Maximum Bore Size		Max. RPM	Continuous Torque ¹	A	C	D1	D2	D3	F	G _{Min}	G _{Max}	H	L1	P	X	Wt. ²
		Square Key																
		in	mm in															
QF15	1 ⁷ / ₃₂	40	9000	452	89.9	32.5	101.3	58.7	64.8	34.0	1.71	5.60	44.5	29.0	49.0	22.4	2.3	
		1 ⁵ / ₈		4001	3.54	1.28	3.99	2.31	2.55	1.34	0.067	0.220	1.75	1.14	1.93	0.88	5	
QF25	5 ⁵ / ₈	50	7000	1407	123.4	50.8	135.6	81.0	85.6	46.0	2.83	4.10	60.7	36.1	66.3	30.7	5.4	
		2 ¹ / ₈		12449	4.86	2.00	5.34	3.19	3.37	1.81	0.111	0.160	2.39	1.42	2.61	1.21	12	
QF50	2 ³ / ₃₂	60	6000	2992	151.4	61.5	184.9	89.4	114.0	54.9	1.81	4.10	75.2	45.2	76.7	42.2	7.7	
		2 ³ / ₈		26479	5.96	2.42	7.28	3.52	4.49	2.16	0.071	0.160	2.96	1.78	3.02	1.66	17	
QF100	1 ⁵ / ₁₆	75	4800	6061	179.6	88.4	197.1	108.0	150.4	62.5	4.35	9.40	86.4	44.7	151.4	55.6	18.1	
		3		53642	7.07	3.48	7.76	4.25	5.92	2.46	0.171	0.370	3.40	1.76	5.96	2.19	40	
QF175	1	95	4200	9973	195.3	93.2	216.4	139.7	171.5	67.8	6.41	9.30	95.3	50.8	156.7	62.2	26.8	
		3 ⁷ / ₈		88257	7.69	3.67	8.52	5.50	6.75	2.67	0.253	0.368	3.75	2.00	6.17	2.45	59	
QF250	1 ¹ / ₂	105	3800	13438	216.2	100.6	261.4	147.1	190.0	78.7	4.13	8.10	106.9	59.2	166.1	63.2	36.7	
		4 ¹ / ₈		118930	8.51	3.96	10.29	5.79	7.48	3.10	0.163	0.318	4.21	2.33	6.54	2.49	81	
QF500	1 ⁷ / ₈	115	3400	24794	257.3	118.6	305.3	177.8	235.0	95.3	4.89	9.53	127.0	69.9	201.2	69.9	61.8	
		4 ¹ / ₂		219429	10.13	4.67	12.02	7.00	9.25	3.75	0.193	0.375	5.00	2.75	7.92	2.75	136	

Notes: ■ 1 indicates: When used with black insert. See pages 12-13 for complete torque ratings.

■ 2 indicates: Weights shown are approximate weights of complete coupling assemblies including two pilot-bore hubs, cover and insert.

Standard Couplings With Low-Speed Split Cover

Standard Coupling with Low-Speed Split Cover

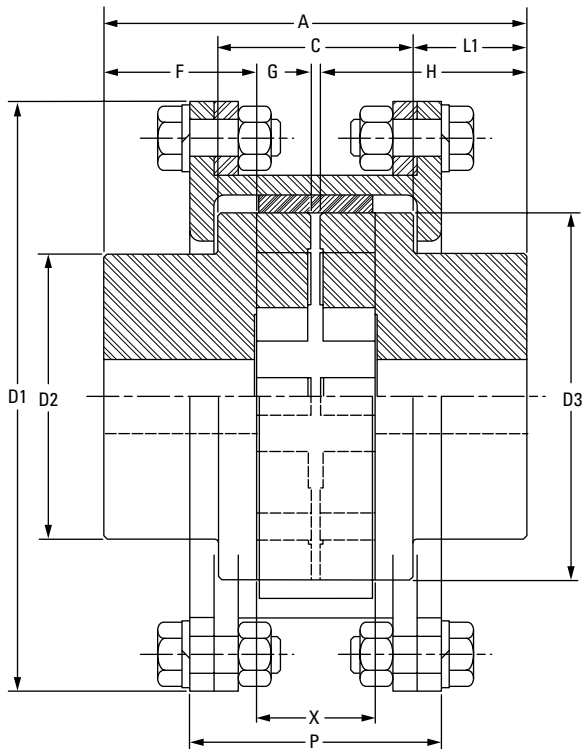

Fig. 24. Standard coupling with low-speed split cover.

Note: When using low-speed split cover, please refer to maximum RPM column in the table at the bottom of this page for allowable speed ratings.

Table 34. QUICK FLEX Insert Continuous Torque Ratings

Coupling Series	Red	Blue	White	Black
	Nm in-lbs	Nm in-lbs	Nm in-lbs	Nm in-lbs
QF15	150	293	293	452
	1324	2594	2594	4001
QF25	484	913	913	1407
	4283	8077	8077	12449
QF50	998	1978	1978	2992
	8833	17502	17502	26479
QF100	2003	3971	3971	6061
	17723	35144	35144	53642
QF175	3475	6656	6656	9973
	30753	58903	58903	88257
QF250	4391	8718	8718	13438
	38864	77158	77158	118930

Table 35. QUICK FLEX Standard Coupling with Low-Speed Split Cover Dimensions

Coupling Series	Pilot-Bore Diameter	Maximum Bore Size	Max. RPM	Continuous Torque ⁽¹⁾	A	C	D1	D2	D3	F	G _{Min}	G _{Max}	H	L1	P	X	Wt. ⁽²⁾
	in	mm in		Nm in-lbs	mm in	mm in	mm in	mm in	mm in	mm in	mm in	mm in	mm in	mm in	mm in	mm in	mm in
QF15	17/32	40	400	452	89.9	32.5	124.2	58.7	64.8	34.0	1.71	2.50	44.5	29.0	50.8	22.4	2.7
		1 5/8		4001	3.54	1.28	4.89	2.31	2.55	1.34	0.067	0.099	1.75	1.14	2.00	0.88	6
QF25	5/8	50	375	1407	123.4	50.8	145.0	81.0	85.6	46.0	2.83	3.40	60.7	36.1	78.0	30.7	5.9
		2 1/8		12449	4.86	2.00	5.71	3.19	3.37	1.81	0.111	0.133	2.39	1.42	3.07	1.21	13
QF50	23/32	60	350	2992	151.4	61.5	192.5	89.4	114.0	54.9	1.81	2.60	75.2	45.2	87.9	42.2	8.6
		2 3/8		26479	5.96	2.42	7.58	3.52	4.49	2.16	0.071	0.101	2.96	1.78	3.46	1.66	19
QF100	15/16	75	300	6061	179.6	88.4	231.9	108.0	150.4	62.5	4.35	9.70	86.4	44.7	118.4	55.6	20.0
		3		53642	7.07	3.48	9.13	4.25	5.92	2.46	0.171	0.380	3.40	1.76	4.66	2.19	44
QF175	1	95	250	9973	195.3	93.2	282.4	139.7	171.5	67.8	6.41	9.50	95.3	50.8	124.0	62.2	32.7
		3 7/8		88257	7.69	3.67	11.12	5.50	6.75	2.67	0.253	0.375	3.75	2.00	4.88	2.45	72
QF250	1 1/2	105	200	13438	216.2	10.6	304.8	147.1	190.0	78.7	4.13	9.30	106.9	59.2	130.3	63.2	39.5
		4 1/8		118930	8.51	3.96	12.00	5.79	7.48	3.10	0.163	0.365	4.21	2.33	5.13	2.49	87

Notes: ■ 1 indicates: When used with black insert. See pages 12-13 for complete torque ratings.
 ■ 2 indicates: Weights shown are approximate weights of complete coupling assemblies including two pilot-bore hubs, cover and insert.

Single-Ended Spacer Couplings

With High-Speed Cover

Single-Ended Spacer Coupling with High-Speed Cover

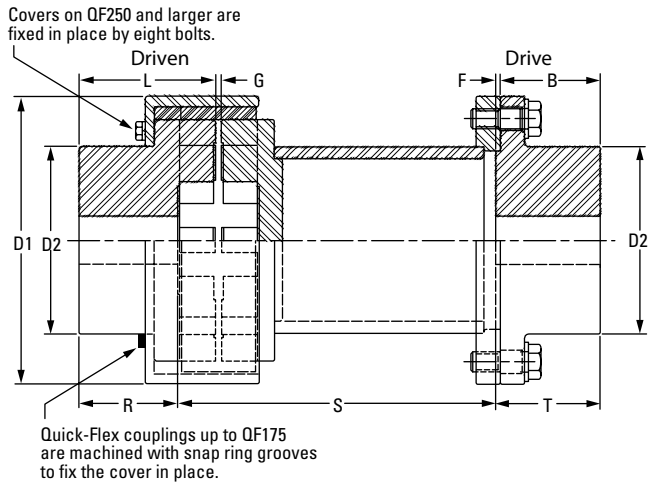

Fig. 25. Single-ended spacer coupling with high-speed cover.

Table 36. QUICK FLEX Insert Continuous Torque Ratings

Coupling Series	Red	Blue	White	Black ¹
	Nm in-lbs	Nm in-lbs	Nm in-lbs	Nm in-lbs
QF5	43	93	93	N/A
	377	819	819	
QF15	120	234	234	N/A
	1059	2075	2075	
QF25	387	730	730	N/A
	3426	6461	6461	
QF50	798	1582	1582	N/A
	7066	14002	14002	
QF100	1602	3177	3177	N/A
	14178	28115	28115	
QF175	2780	5325	5325	N/A
	24602	47123	47123	
QF250	3513	6975	6975	N/A
	31091	61726	61726	
QF500	6790	13051	13051	N/A
	60091	115497	115497	
QF1000	9601	18418	18418	N/A
	84966	162997	162997	
QF1890	10740	20409	20409	N/A
	95061	180639	180639	
QF3150	11880	22401	22401	N/A
	105135	198252	198252	
QF10260	23748	44736	44736	N/A
	210173	395913	395913	

Note: ■ 1 indicates: When using a high-speed cover, the use of a black insert is not recommended. In an application where high torque is present, use a Split Cover option. Contact your Lovejoy application engineer for maximum shaft distance.

Table 37. QUICK FLEX Single-Ended Spacer Coupling with High-Speed Cover Dimensions

Coupling Series	Pilot-Bore Diameter	Maximum Bore Size		Continuous Torque ¹	B	D1	D2	F	G _{Min}	G _{Max}	L	R	S _{Max} ²	T
		Square Key	Shallow Key											
		in	mm in											
QF15	17/32	40	-	234	38.1	80.3	58.7	1.0	1.71	2.80	44.5	34.0	255	39.1
		1 3/8	-	2075	1.50	3.16	2.31	0.04	0.067	0.110	1.75	1.34	10	1.54
QF25	5/8	50	-	730	51.1	106.9	81.0	1.0	2.83	5.20	60.7	46.0	305	52.1
		2 1/8	-	6461	2.01	4.21	3.19	0.04	0.111	0.205	2.39	1.81	12	2.05
QF50	23/32	60	-	1582	61.2	139.2	89.4	1.0	1.81	5.30	75.2	54.9	355	62.2
		2 3/8	-	14002	2.41	5.48	3.52	0.04	0.071	0.208	2.96	2.16	14	2.45
QF100	15/16	75	-	3177	60.5	177.8	108.0	3.8	4.35	7.40	86.4	61.0	405	64.3
		3	-	28115	2.38	7.00	4.25	0.15	0.171	0.290	3.40	2.40	16	2.53
QF175	1	95	-	5325	72.4	203.2	139.7	3.8	6.41	5.30	95.3	66.5	455	76.2
		3 7/8	-	47123	2.85	8.00	5.50	0.15	0.253	0.208	3.75	2.62	18	3.00
QF250	1 1/2	105	-	6975	78.2	225.6	147.1	3.8	4.13	5.80	106.9	77.7	505	82.0
		4 1/8	-	61726	3.08	8.88	5.79	0.15	0.163	0.230	4.21	3.06	20	3.23
QF500	1 7/8	115	-	13051	94.5	273.6	177.8	3.8	4.89	6.40	127.0	94.5	610	94.5
		4 1/2	-	115497	3.72	10.77	7.00	0.15	0.193	0.250	5.00	3.72	24	3.72
QF1000	1 7/8	140	-	18418	116.8	308.1	198.4	3.8	5.65	9.86	152.4	116.8	760	166.8
		5 1/2	6 3/16	162997	4.60	12.13	7.81	0.15	0.223	0.388	6.00	4.60	30	4.60
QF1890	2 1/2	175	-	20409	145.8	365.3	241.3	3.8	6.62	7.06	184.4	145.8	760	145.8
		6 1/2	7 1/2	180639	5.74	14.38	9.50	0.15	0.261	0.278	7.26	5.74	30	5.74
QF3150	2 1/2	205	-	22401	157.0	425.5	279.4	5.1	3.37	7.75	202.7	157.0	915	157.0
		6 1/2	9	198252	6.18	16.75	11.00	0.20	0.133	0.305	7.98	6.18	36	6.18
QF10260	2 1/2	280	-	44736	183.4	510.5	381.0	5.1	4.64	12.83	251.0	183.4	915	183.4
		6 1/2	11 1/4	395913	7.22	20.10	15.00	0.20	0.183	0.505	9.88	7.22	36	7.22

Notes: ■ 1 indicates: When used with blue insert. See pages 10-11 for complete torque ratings.
 ■ 2 indicates: Dimension shown is maximum distance between shafts. Please provide S dimension when ordering.

Single-Ended Spacer Couplings

With High-Speed Split Cover

Single-Ended Spacer Coupling with High-Speed Split Cover

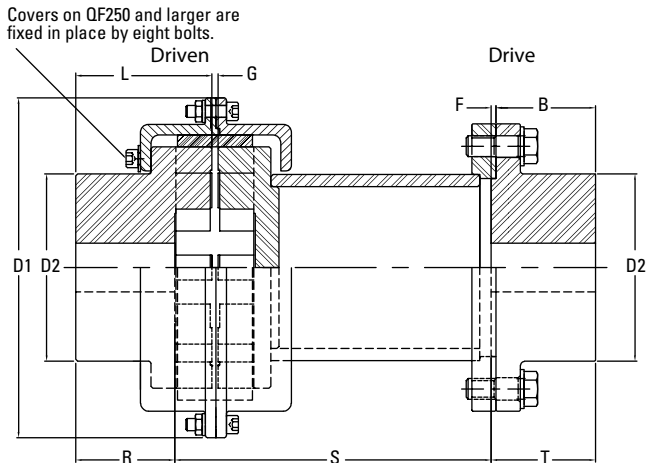

Fig. 26. Single-ended spacer coupling with high-speed split cover.

Table 38. QUICK FLEX Insert Continuous Torque Ratings

Coupling Series	Red	Blue	White	Black
	Nm in-lbs	Nm in-lbs	Nm in-lbs	Nm in-lbs
QF15	150	293	293	452
	1324	2594	2594	4001
QF25	484	913	913	1407
	4283	8077	8077	12449
QF50	998	1978	1978	2992
	8833	17502	17502	26479
QF100	2003	3971	3971	6061
	17723	35144	35144	53642
QF175	3475	6656	6656	9973
	30753	58903	58903	88257
QF250	4391	8718	8718	13438
	38864	77158	77158	118930
QF500	8487	16313	16313	24794
	75114	144372	144372	219429
QF1000	12001	23022	23022	35081
	106208	203746	203746	310466
QF1890	19869	38937	38937	62597
	175840	344594	344594	553982
QF3150	33942	64004	64004	98434
	300387	566434	566434	871139
QF10260	67852	127817	127817	188794
	600494	1131179	1131179	1670826

Table 39. QUICK FLEX Single-Ended Spacer Coupling with High-Speed Split Cover Dimensions

Coupling Series	Pilot-Bore Diameter	Maximum Bore Size		Continuous Torque ¹	B	D1	D2	F	G _{Min}	G _{Max}	L	R	S _{Max} ²	T
		Square Key	Shallow Key											
		in	mm in											
QF15	17/32	40	-	452	38.1	119.4	58.7	1.0	1.71	3.20	44.5	34.0	255	39.1
		1 5/8	-	4001	1.50	4.70	2.31	0.04	0.067	0.126	1.75	1.34	10	1.54
QF25	5/8	50	-	1407	51.1	142.6	81.0	1.0	2.83	3.60	60.7	46.0	305	52.1
		2 1/8	-	12449	2.01	5.62	3.19	0.04	0.111	0.140	2.39	1.81	12	2.05
QF50	23/32	60	-	2992	61.2	193.5	89.4	1.0	1.81	5.60	75.2	54.9	355	62.2
		2 3/8	-	26479	2.41	7.62	3.52	0.04	0.071	0.220	2.96	2.16	14	2.45
QF100	15/16	75	-	6061	60.5	227.3	108.0	3.8	4.35	9.70	86.4	61.0	405	64.3
		3	-	53642	2.38	8.95	4.25	0.15	0.171	0.380	3.40	2.40	16	2.53
QF175	1	95	-	9973	72.4	250.2	139.7	3.8	6.41	8.80	95.3	66.5	455	76.2
		3 7/8	-	88257	2.85	9.85	5.50	0.15	0.253	0.348	3.75	2.62	18	3.00
QF250	1 1/2	105	-	13438	78.2	266.7	147.1	3.8	4.13	6.60	106.9	77.7	505	82.0
		4 1/8	-	118930	3.08	10.50	5.79	0.15	0.163	0.258	4.21	3.06	20	3.23
QF500	1 7/8	115	-	24794	94.5	342.9	177.8	3.8	4.89	9.50	127.0	94.5	610	94.5
		4 1/2	-	219429	3.72	13.50	7.00	0.15	0.193	0.375	5.00	3.72	24	3.72
QF1000	1 7/8	140	-	35081	116.8	387.4	198.4	3.8	5.65	10.40	152.4	116.8	760	166.8
		5 1/2	6 3/16	310466	4.60	15.25	7.81	0.15	0.223	0.410	6.00	4.60	30	4.60
QF1890	2 1/2	175	-	62597	145.8	450.9	241.3	3.8	6.62	11.50	184.4	145.8	760	145.8
		6 1/2	7 1/2	553982	5.74	17.75	9.50	0.15	0.261	0.454	7.26	5.74	30	5.74
QF3150	2 1/2	205	-	98434	157.0	497.6	279.4	5.1	3.37	9.652	202.7	157.0	915	157.0
		6 1/2	9	871139	6.18	19.59	11.00	0.20	0.133	0.380	7.98	6.18	36	6.18
QF10260	2 1/2	280	-	188794	183.4	619.3	381.0	5.1	4.64	12.50	251.0	183.4	915	183.4
		6 1/2	11 1/4	1670826	7.22	24.38	15.00	0.20	0.183	0.492	9.88	7.22	36	7.22

Notes: ■ 1 indicates: When used with black insert. See pages 12-13 for complete torque ratings.
 ■ 2 indicates: Dimension shown is maximum distance between shafts. Please provide S dimension when ordering.
 ■ Spacer bodies ordered with High-Speed Split Covers need to be ordered as HVSPCOVER for fitting purposes.

Single-Ended Spacer Couplings

With Aluminum High-Performance (HP) Cover

Single-Ended Spacer Coupling with Aluminum High-Performance (HP) Cover

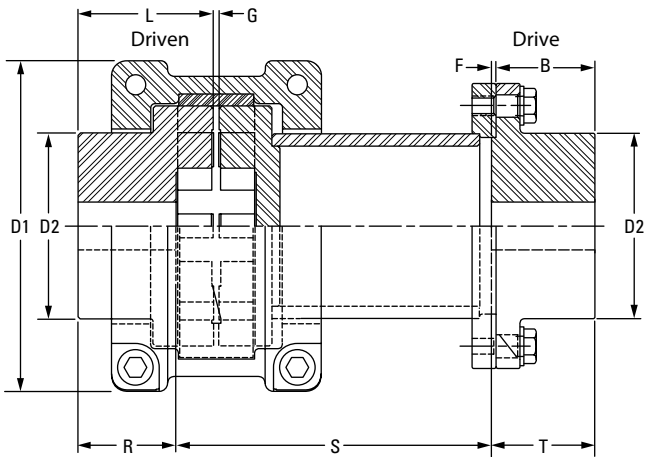

Fig. 27. Single-Ended spacer coupling with aluminum high-performance cover.

Table 40. QUICK FLEX Insert Continuous Torque Ratings

Coupling Series	Red	Blue	White	Black
	Nm in-lbs	Nm in-lbs	Nm in-lbs	Nm in-lbs
QF15	150	293	293	452
	1324	2594	2594	4001
QF25	484	913	913	1407
	4283	8077	8077	12449
QF50	998	1978	1978	2992
	8833	17502	17502	26479
QF100	2003	3971	3971	6061
	17723	35144	35144	53642
QF175	3475	6656	6656	9973
	30753	58903	58903	88257
QF250	4391	8718	8718	13438
	38864	77158	77158	118930
QF500	8487	16313	16313	24794
	75114	144372	144372	219429

Table 41. QUICK FLEX Single-Ended Spacer Coupling with Aluminum High-Performance (HP) Cover Dimensions

Coupling Series	Pilot-Bore Diameter	Maximum Bore Size	Continuous Torque ¹	B	D1	D2	F	G _{Min}	G _{Max}	L	R	S _{Max} ²	T
		Square Key											
	in	mm in	Nm in-lbs	mm in	mm in	mm in	mm in	mm in	mm in	mm in	mm in	mm in	
QF15	17/32	40	452	38.1	101.3	58.7	1.0	1.71	5.60	44.5	34.0	255	39.1
		1 5/8	4001	1.50	3.99	2.31	0.04	0.067	0.220	1.75	1.34	10	1.54
QF25	5/8	50	1407	51.1	135.6	81.0	1.0	2.83	4.10	44.5	46.0	305	52.1
		2 1/8	12449	2.01	5.34	3.19	0.04	0.111	0.160	2.39	1.81	12	2.05
QF50	23/32	60	2992	61.2	184.9	89.4	1.0	1.81	4.10	75.2	54.9	355	62.2
		2 3/8	26479	2.41	7.28	3.52	0.04	0.071	0.160	2.96	2.16	14	2.45
QF100	15/16	75	6061	60.5	197.1	108.0	3.8	4.35	9.40	86.4	61.0	405	64.3
		3	53642	2.38	7.76	4.25	0.15	0.171	0.370	3.4	2.40	16	2.53
QF175	1	95	9973	72.4	216.4	139.7	3.8	6.41	9.30	95.3	66.4	455	76.2
		3 7/8	88257	2.85	8.52	5.50	0.15	0.253	0.368	3.75	2.62	18	3.00
QF250	1 1/2	105	13438	78.2	261.4	147.1	3.8	4.13	8.10	106.9	77.7	510	82.0
		4 1/8	118930	3.08	10.29	5.79	0.15	0.163	0.318	4.21	3.06	20	3.23
QF500	1 7/8	115	24794	94.5	305.3	177.8	3.8	4.89	9.53	127.0	94.5	610	94.5
		4 1/2	219429	3.72	12.02	7.00	0.15	0.193	0.375	5.00	3.72	24	3.72

Notes: ■ 1 indicates: When used with black insert. See pages 12-13 for complete torque ratings.

■ 2 indicates: Dimension shown is maximum distance between shafts. Please provide S dimension when ordering.

Double-Ended Spacer Couplings

With High-Speed Covers

Double-Ended Spacer Coupling with High-Speed Covers

Covers on QF250 and larger are fixed in place by eight bolts.

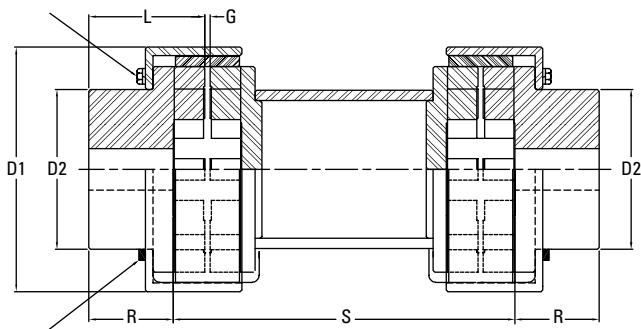

Quick-Flex couplings up to QF175 are machined with snap-ring grooves to fix the cover in place.

Fig. 28. Double-ended spacer coupling with high-speed covers.

Table 42. QUICK FLEX Insert Continuous Torque Ratings

Coupling Series	Red	Blue	White	Black ¹
	Nm in-lbs	Nm in-lbs	Nm in-lbs	Nm in-lbs
QF5	43	93	93	N/A
	377	819	819	
QF15	120	234	234	N/A
	1059	2075	2075	
QF25	387	730	730	N/A
	3426	6461	6461	
QF50	798	1582	1582	N/A
	7066	14002	14002	
QF100	1602	3177	3177	N/A
	14178	28115	28115	
QF175	2780	5325	5325	N/A
	24602	47123	47123	
QF250	3513	6975	6975	N/A
	31091	61726	61726	
QF500	6790	13051	13051	N/A
	60091	115497	115497	
QF1000	9601	18418	18418	N/A
	84966	162997	162997	

Note: ■ 1 indicates: When using a high-speed cover, the use of a black insert is not recommended. In an application where high torque is present, use a Split Cover option. Contact your Lovejoy application engineer for maximum shaft distance.

Table 43. QUICK FLEX Double-Ended Spacer Coupling with High-Speed Covers Dimensions

Coupling Series	Pilot-Bore Diameter	Maximum Bore Size		Continuous Torque ¹	D1	D2	G _{Min}	G _{Max}	L	R	S ²
		Square Key	Shallow Key								
		in	mm in								
QF15	17/32	40	–	234	80.3	58.7	1.71	2.800	44.5	34.0	2
		1 5/8	–	2075	3.16	2.31	0.067	0.110	1.75	1.34	
QF25	5/8	50	–	730	106.9	81.0	2.83	5.200	60.7	46.0	2
		2 1/8	–	6461	4.21	3.19	0.111	0.205	2.39	1.81	
QF50	23/32	60	–	1582	139.2	89.4	1.81	5.300	75.2	54.9	2
		2 3/8	–	14002	5.48	3.52	0.071	0.208	2.96	2.16	
QF100	15/16	75	–	3177	177.8	108.0	4.35	7.400	86.4	61.0	2
		3	–	28115	7.00	4.25	0.171	0.290	3.40	2.40	
QF175	1	95	–	5325	203.2	139.7	6.41	5.300	95.3	66.5	2
		3 7/8	–	47123	8.00	5.50	0.253	0.208	3.75	2.62	
QF250	1 1/2	105	–	6975	225.6	147.1	4.13	5.800	106.9	77.7	2
		4 1/8	–	61726	8.88	5.79	0.163	0.230	4.21	3.06	
QF500	1 7/8	115	–	13051	273.6	177.8	4.89	6.400	127.0	94.5	2
		4 1/2	–	115497	10.77	7.00	0.193	0.250	5.00	3.72	
QF1000	1 7/8	140	–	18418	308.1	198.4	5.65	4.10	9.86	116.8	2
		5 1/2	6 3/16	162997	12.13	7.81	0.223	0.160	0.388	4.60	

Notes: ■ 1 indicates: When used with blue insert. See pages 10-11 for complete torque ratings.
 ■ 2 indicates: Customer to provide S dimension when ordering.

Double-Ended Spacer Couplings With High-Speed Split Covers

Double-Ended Spacer Coupling with High-Speed Split Covers

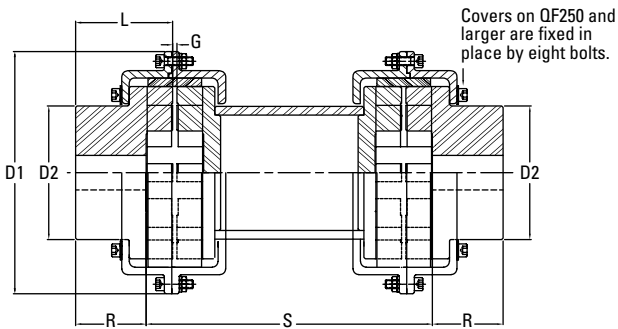

Fig. 29. Double-ended spacer coupling with high-speed split covers.

Table 44. QUICK FLEX Insert Continuous Torque Ratings

Coupling Series	Red	Blue	White	Black
	Nm in-lbs	Nm in-lbs	Nm in-lbs	Nm in-lbs
QF15	150	293	293	452
	1324	2594	2594	4001
QF25	484	913	913	1407
	4283	8077	8077	12449
QF50	998	1978	1978	2992
	8833	17502	17502	26479
QF100	2003	3971	3971	6061
	17723	35144	35144	53642
QF175	3475	6656	6656	9973
	30753	58903	58903	88257
QF250	4391	8718	8718	13438
	38864	77158	77158	118930
QF500	8487	16313	16313	24794
	75114	144372	144372	219429
QF1000	12001	23022	23022	35081
	106208	203746	203746	310466
QF1890	19869	38937	38937	62597
	175840	344594	344594	553982
QF3150	33942	64004	64004	98434
	300387	566434	566434	871139
QF10260	67852	127817	127817	188794
	600494	1131179	1131179	1670826

Table 45. QUICK FLEX Double-Ended Spacer Coupling with High-Speed Split Cover Dimensions

Coupling Series	Pilot-Bore Diameter	Maximum Bore Size		Continuous Torque ¹	D1	D2	G _{Min}	G _{Max}	L	R	S ²
		Square Key	Shallow Key								
		in	mm in								
QF15	17/32	40	–	452	119.4	58.7	1.71	3.20	44.5	34.0	2
		1 5/8	–	4001	4.70	2.31	0.067	0.126	1.75	1.34	
QF25	5/8	50	–	1407	142.7	81.0	2.83	3.60	60.7	46.0	2
		2 1/8	–	12449	5.62	3.19	0.111	0.140	2.39	1.81	
QF50	23/32	60	–	2992	193.5	89.4	1.81	5.60	75.2	54.9	2
		2 3/8	–	26479	7.62	3.52	0.071	0.220	2.96	2.16	
QF100	15/16	75	–	6061	227.3	108.0	4.35	9.70	86.4	61.0	2
		3	–	53642	8.95	4.25	0.171	0.380	3.40	2.40	
QF175	1	95	–	9973	250.2	139.7	6.41	8.80	95.3	66.5	2
		3 7/8	–	88257	9.85	5.50	0.253	0.348	3.75	2.62	
QF250	1 1/2	105	–	13438	266.7	147.1	4.13	6.60	106.9	77.7	2
		4 1/8	–	118930	10.50	5.79	0.163	0.258	4.21	3.06	
QF500	1 7/8	115	–	24794	342.9	177.8	4.89	9.50	127.0	94.5	2
		4 1/2	–	219429	13.5	7.00	0.193	0.375	5.00	3.72	
QF1000	1 7/8	140	–	35081	387.4	198.4	5.65	10.40	152.4	116.8	2
		5 1/2	6 3/16	310466	15.25	7.81	0.223	0.410	6.00	4.60	
QF1890	2 1/2	175	–	62597	450.9	241.3	6.62	11.50	184.4	145.8	2
		6 1/2	7 1/2	553982	17.75	9.50	0.261	0.454	7.26	5.74	
QF3150	2 1/2	205	–	98434	497.6	279.4	3.37	9.652	202.7	157.0	2
		6 1/2	9	871139	19.59	11.00	0.133	0.380	7.98	6.18	
QF10260	2 1/2	280	–	188794	619.3	381.0	4.64	12.50	251.0	183.4	2
		6 1/2	11 1/4	1670826	24.38	15.00	0.183	0.492	9.88	7.22	

Notes: ■ 1 indicates: When used with black insert. See pages 12-13 for complete torque ratings.
 ■ 2 indicates: Customer to provide S dimension when ordering.
 ■ Spacer bodies ordered with High-Speed Split Covers need to be ordered as HVSPCOVER for fitting purposes.

Double-Ended Spacer Couplings

With Aluminum High-Performance (HP) Covers

Double-Ended Spacer Coupling with Aluminum High-Performance (HP) Covers

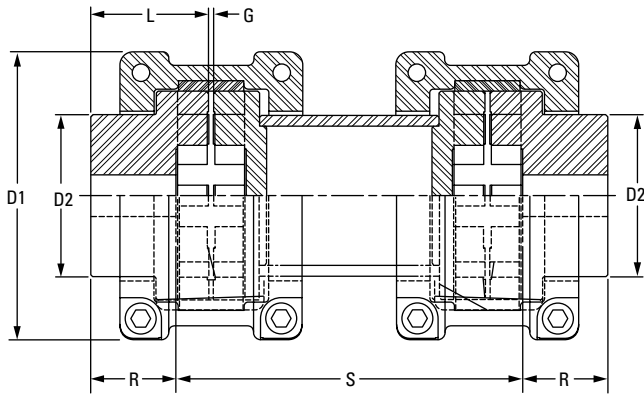

Fig. 30. Double-ended spacer coupling with aluminum high-performance covers.

Table 46. QUICK FLEX Insert Continuous Torque Ratings

Coupling Series	Red	Blue	White	Black
	Nm in-lbs	Nm in-lbs	Nm in-lbs	Nm in-lbs
QF15	150	293	293	452
	1324	2594	2594	4001
QF25	484	913	913	1407
	4283	8077	8077	12449
QF50	998	1978	1978	2992
	8833	17502	17502	26479
QF100	2003	3971	3971	6061
	17723	35144	35144	53642
QF175	3475	6656	6656	9973
	30753	58903	58903	88257
QF250	4391	8718	8718	13438
	38864	77158	77158	118930
QF500	8487	16313	16313	24794
	75114	144372	144372	219429

Table 47. QUICK FLEX Double-Ended Spacer Coupling with Aluminum High-Performance (HP) Cover Dimensions

Coupling Series	Pilot-Bore Diameter	Maximum Bore Size	Continuous Torque ¹	D1	D2	G _{Min}	G _{Max}	L	R	S ²
		Square Key								
	in	mm in	Nm in-lbs	mm in	mm in	mm in	mm in	mm in	mm in	
QF15	17/32	40	452	101.3	58.7	1.71	5.60	44.5	34.0	2
		1 5/8	4001	3.99	2.31	0.067	0.220	1.75	1.34	
QF25	5/8	50	1407	135.6	81.0	2.83	4.00	60.7	46.0	2
		2 1/8	12449	5.34	3.19	0.111	0.160	2.39	1.81	
QF50	23/32	60	2992	184.9	89.4	1.81	4.00	75.2	54.9	2
		2 3/8	26479	7.28	3.52	0.071	0.160	2.96	2.16	
QF100	15/16	75	6061	197.1	108.0	4.35	9.40	86.4	61.0	2
		3	53642	7.76	4.25	0.171	0.370	3.40	2.40	
QF175	1	95	9973	216.4	139.7	6.41	9.30	95.3	66.5	2
		3 7/8	88257	8.52	5.50	0.253	0.368	3.75	2.62	
QF250	1 1/2	105	13438	261.4	147.1	4.13	8.10	106.9	77.7	2
		4 1/8	118930	10.29	5.79	0.163	0.318	4.21	3.06	
QF500	1 7/8	115	24794	305.31	177.8	4.89	9.53	127.0	94.49	2
		4 1/2	219429	12.02	7.00	0.193	0.375	5.00	3.72	

Notes: ■ 1 indicates: When used with black insert. See pages 12-13 for complete torque ratings.
 ■ 2 indicates: Customer to provide S dimension when ordering.

Double-Ended Spacer Flange Couplings

With High-Speed Split Covers

Double-Ended Spacer Flange Coupling with High-Speed Split Covers

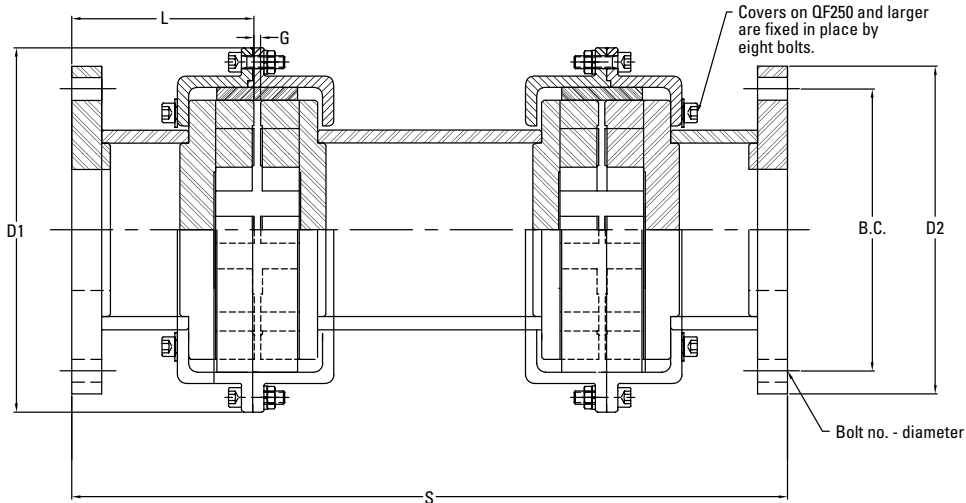

Fig. 31. Double-ended spacer flange coupling with high-speed split covers.

Table 48. QUICK FLEX Double-Ended Spacer Flange Coupling with High-Speed Split Cover Dimensions

Coupling Series	G52 Gear Coupling	Continuous Torque ¹	B.C.	D1	D2	G _{Min}	G _{Max}	L	S ²	S _{Min}
		Nm in-lbs	mm in	mm in	mm in	mm in	mm in	mm in	mm in	mm in
QF25	1010G52	1407	95.3	147.8	115.9	2.83	3.56	59.2	2	198.1
		12449	3.75	5.62	4.56	0.111	0.140	2.33		7.80
QF50	1015G52	2992	122.2	193.5	152.4	1.81	5.59	78.2	2	263.7
		26479	4.81	7.62	6.00	0.071	0.220	3.08		10.38
QF100	1020G52	6061	149.2	227.3	177.8	4.35	9.65	100.1	2	345.4
		53642	5.88	8.95	7.00	0.171	0.380	3.94		13.60
QF175	1025G52	9973	181.0	250.2	212.7	6.41	8.84	112.5	2	374.7
		88257	7.13	9.85	8.38	0.253	0.348	4.43		14.75
QF250	1030G52	13438	206.4	266.7	239.7	4.13	6.55	154.2	2	451.4
		118930	8.13	10.50	9.44	0.163	0.258	6.07		17.77
QF500	1035G52	24794	241.3	342.9	279.4	4.89	9.53	188.2	2	563.9
		219429	9.50	13.50	11.00	0.193	0.375	7.41		22.20
QF500	1040G52	24794	279.4	312.2	317.5	4.89	9.53	188.2	2	563.9
		219429	11.00	12.29	12.50	0.193	0.375	7.41		22.20
QF1000	1045G52	35081	304.8	387.4	346.1	5.65	10.41	192.0	2	580.1
		310466	12.00	15.25	13.63	0.223	0.410	7.56		22.84
QF1890	1050G52	62597	342.9	450.9	389.0	6.62	11.53	219.7	2	673.1
		553982	13.50	17.75	15.31	0.261	0.454	8.65		26.50
QF1890	1055G52	62597	368.3	450.9	425.4	6.62	11.53	219.7	2	673.1
		553982	14.50	17.75	16.75	0.261	0.454	8.65		26.50
QF3150	1060G52	98434	400.1	497.6	457.2	3.37	11.56	209.0	2	644.7
		871138	15.75	19.59	18.00	0.133	0.455	8.23		25.38
QF10260	1070G52	188794	469.9	619.3	527.1	4.64	12.50	258.6	2	850.9
		1670826	18.50	24.38	20.75	0.183	0.492	10.18		33.50
QF10260	1080G52	188794	527.1	619.3	603.3	4.64	12.50	266.5	2	866.1
		1670826	20.75	24.38	23.75	0.183	0.492	10.49		34.10
QF10260	1090G52	188794	590.6	619.3	660.4	4.64	12.50	276.6	2	886.0
		1670826	23.25	24.38	26.00	0.183	0.492	10.89		34.88

Notes: ■ 1 indicates: When used with black insert. See pages 12-13 for complete torque ratings.
 ■ 2 indicates: Customer to provide S dimension when ordering.
 ■ Spacer bodies ordered with High-Speed Split Covers need to be ordered as HVSPCOVER for fitting purposes.

Bushing-Style Interchange Couplings

Browning® Style Hubs

Bushing-Style Interchange Couplings

QUICK FLEX Browning® Style Hubs

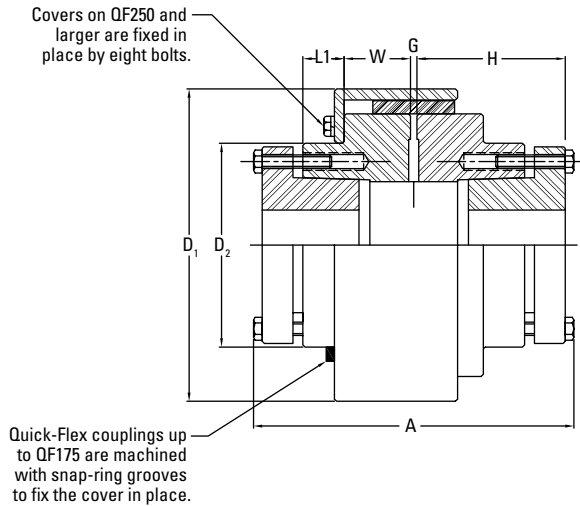

Note: Bushing-style couplings are available with all cover and insert options. Bushings are not supplied with QUICK FLEX bushing-style interchange coupling hubs.

Fig. 32. QUICK FLEX Browning® style hubs.

Table 49. QUICK FLEX Browning® Style Hub Dimensions

Coupling Series	Bushing Part No.	Bushing Torque Ratings	Bore Range	A	D1	D2	G _{Min}	G _{Max}	H	L1	W	Wt.
		Nm in-lbs	mm in	mm in	mm in	mm in	mm in	mm in	mm in	mm in	mm in	kg lbs
QF5	G	203	10 - 25	69.9	63.2	50.8	2.47	2.30	23.1	11.4	12.7	0.9
		1800	½ - 1	2.75	2.49	2.00	0.097	0.092	0.91	0.45	0.50	2
QF15 ¹	H	421	10 - 38	77.7	80.3	58.7	1.71	2.50	33.3	17.8	15.5	2.3
		3730	¾ - 1 ½	3.06	3.16	2.31	0.067	0.099	1.31	0.70	0.61	5
QF25	P1	1069	14 - 42	141.7	106.9	81.0	2.83	5.20	70.1	23.4	24.4	3.6
		9460	½ - 1 ¾	5.58	4.21	3.19	0.111	0.205	2.76	0.92	0.96	8
QF50	P1	1164	14 - 42	153.2	139.7	89.4	1.81	5.30	75.7	23.6	30.0	5.9
		10300	½ - 1 ¾	6.03	5.50	3.52	0.071	0.208	2.98	0.93	1.18	13
QF100	Q1	2316	18 - 65	193.8	108.0	108.0	4.35	7.40	94.5	26.4	41.7	10.9
		20500	¾ - 2 1/16	7.63	4.25	4.25	0.171	0.290	3.72	1.04	1.64	24
QF175	R1	4621	28 - 95	220.0	203.2	139.7	6.41	5.30	100.6	33.8	44.5	15.4
		40900	1 ⅛ - 3 ¾	8.66	8.00	5.50	0.253	0.208	3.96	1.33	1.75	34
QF250	R1	4621	28 - 95	221.5	225.3	147.1	4.13	5.80	108.2	31.0	47.8	20.4
		40900	1 ⅛ - 3 ¾	8.72	8.87	5.79	0.163	0.230	4.26	1.22	1.88	45
QF500	S1	5876	42 - 100	309.4	273.6	177.8	4.89	6.40	152.4	58.7	57.2	43.5
		52000	1 1/16 - 4 ¼	12.18	10.77	7.00	0.193	0.250	6.00	2.31	2.25	96

Notes: ■ 1 indicates: Available with low-speed split cover only.

■ Bushing limits torque rating and speed rating.

■ Lovejoy is not affiliated with EPT®, owner of the Browning® trademark.

Bushing-Style Interchange Couplings

QD® Style Hubs

QUICK FLEX QD® Style Hubs

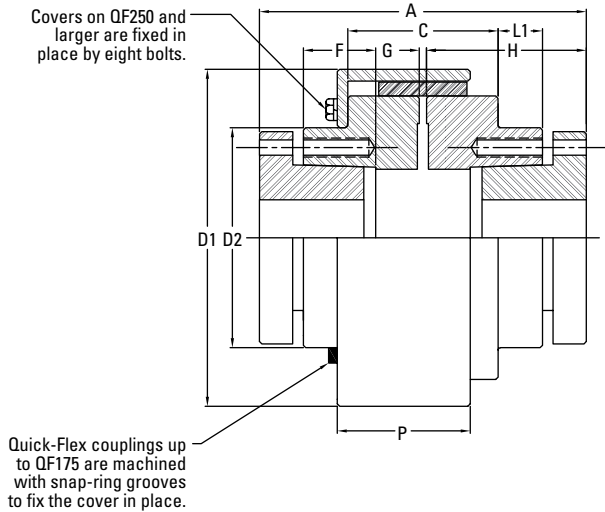

Note: Bushings are not supplied with QUICK FLEX bushing-style interchange coupling hubs. Bushing-style couplings are available with all cover and insert options.

Fig. 33. QUICK FLEX QD® style hubs.

Table 50. QUICK FLEX QD® Style Hub Dimensions

Coupling Series	Bushing Type	Bushing Torque Rating	Bore Range	A	C	D1	D2	F	G _{Min}	G _{Max}	H	L1	P	Wt.
		Nm in-lbs	mm in	mm in	mm in	mm in	mm in	mm in	mm in	mm in	mm in	mm in	mm in	kg lbs
QF15 ¹	JA	113	24 - 28	90.4	32.5	80.3	58.7	21.3	1.71	2.50	44.5	16.3	33.8	2.3
		1000	½ - 1 ¼	3.56	1.28	3.16	2.31	0.84	0.067	0.099	1.75	0.64	1.33	5
QF25	SD	395	24 - 42	122.7	50.5	106.9	81.0	29.2	2.83	5.20	60.7	19.3	49.0	4.1
		3500	½ - 1 ⅞	4.83	1.99	4.21	3.19	1.15	0.111	0.205	2.39	0.76	1.93	9
QF50	SD	565	24 - 42	151.9	61.5	139.7	89.4	38.1	1.81	5.30	75.2	28.4	45.7	6.8
		5000	½ - 2	5.98	2.42	5.50	3.52	1.50	0.071	0.208	2.96	1.12	1.80	15
QF100	SK	791	24 - 55	177.5	88.4	177.8	108.0	42.7	4.35	7.40	86.4	24.6	75.2	11.3
		7000	½ - 2 ⅝	6.99	3.48	7.00	4.25	1.68	0.171	0.290	3.40	0.97	2.96	25
QF175	SF	1243	28 - 60	194.8	93.2	203.2	139.7	46.5	6.41	5.30	95.3	29.5	83.1	15.9
		11000	½ - 2 15/16	7.67	3.67	8.00	5.50	1.83	0.253	0.208	3.75	1.16	3.27	35
QF250	SF	1243	28 - 60	218.7	100.6	225.6	147.1	57.4	4.13	5.80	107.0	37.6	90.0	21.3
		11000	½ - 2 15/16	8.61	3.96	8.88	5.79	2.26	0.163	0.230	4.21	1.48	3.50	47
QF500	F	3390	45 - 90	270.0	119.1	273.6	177.8	66.8	4.89	6.40	132.6	41.4	102.3	44.9
		30000	1 - 4	10.63	4.69	10.77	7.00	2.63	0.193	0.250	5.22	1.63	4.05	99

Notes: ■ 1 indicates: Available with low-speed split cover only.
 ■ Bushing limits torque rating and speed rating.
 ■ Lovejoy is not affiliated with Baldor, owner of the QD® trademark.

Bushing-Style Interchange Couplings

Taper-Lock® Style Hubs

QUICK FLEX TAPER-LOCK® Style Hubs

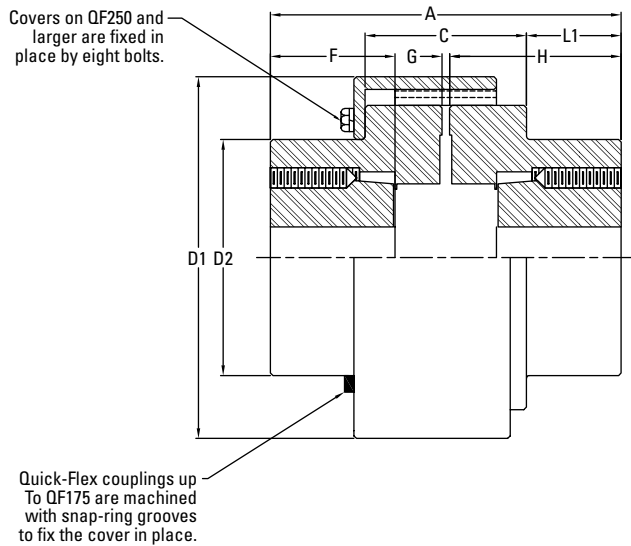

Note: Bushings are not supplied with QUICK FLEX bushing-style interchange coupling hubs. Bushing-style couplings are available with all cover and insert options.

Fig. 34. QUICK FLEX Taper-Lock® style hubs.

Table 51. QUICK FLEX TAPER-LOCK® Style Hub Dimensions

Coupling Series	Bushing Type	Bushing Torque Rating Nm in-lbs	Bore Range mm in	Maximum RPM	A	C	D1	D2	F	G _{Min}	G _{Max}	H	L1	Wt.
					mm in	mm in	mm in	mm in	mm in	mm in	mm in	mm in	mm in	kg lbs
QF5	1108	136	14 - 25	5000	70.9	26.2	63.2	50.8	22.6	2.47	2.30	34.8	17.8	1.8
		1200	½ - 1 ⅛		2.79	1.03	2.49	2.00	0.89	0.097	0.092	1.37	0.70	4
QF25	1610	486	14 - 40	4500	92.5	50.8	106.9	81.0	26.2	2.83	5.20	43.4	18.8	3.6
		4300	½ - 1 ¾		3.64	2.00	4.21	3.19	1.03	0.111	0.205	1.71	0.74	8
QF50	2012	808	14 - 48	4000	108.2	61.5	139.7	89.4	38.4	1.81	5.30	53.3	31.5	6.4
		7150	½ - 1 ⅞		4.26	2.42	5.50	3.52	1.51	0.071	0.208	2.10	1.24	14
QF100	2517	1311	14 - 65	3200	172.2	88.4	177.8	108.0	75.7	4.35	7.40	83.8	41.9	11.3
		11600	¾ - 2 11/16		6.78	3.48	7.00	4.25	2.98	0.171	0.290	3.30	1.65	25
QF175	3020	2712	24 - 75	2800	196.9	93.2	203.2	139.7	79.2	6.41	5.30	96.0	51.8	15.4
		24000	1 ⅛ - 3 ¼		7.75	3.67	8.00	5.50	3.12	0.253	0.208	3.78	2.04	34
QF250	3020	2712	24 - 75	2500	202.9	100.6	225.3	147.1	83.6	4.13	5.80	99.1	53.3	20.9
		24000	1 ⅛ - 3 ¼		7.99	3.96	8.87	5.79	3.29	0.163	0.230	3.90	2.10	46

Notes: ■ Bushing limits torque rating and speed rating.
 ■ Lovejoy is not affiliated with Reliance Electric Industrial Company, owner of the TAPER-LOCK® trademark.

Splined-Hub Couplings

Splined Hubs

QUICK FLEX Splined Hubs

All of our splined-hub couplings come standard with blind set screws. Since the set screws never touch the shaft, there is never any damage to the splined shaft, all the while spreading the pressure over a larger area for a tighter compression.

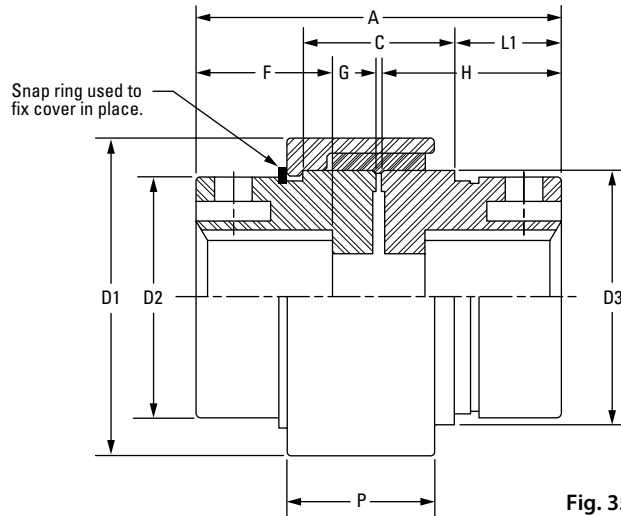

Note: Splined-hub couplings are available with all cover and insert options.

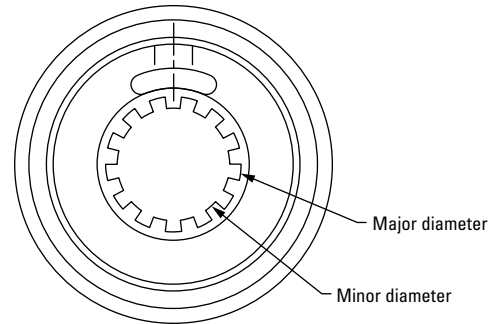

Fig. 35. QUICK FLEX splined hubs.

Table 52. QUICK FLEX Splined-Hub Dimensions

Part Number	Coupling Series	Spline Form				
		No. of Teeth	Pitch	Pitch Diameter	Major Diameter	Minor Diameter
			in	in	in	in
QF25SPL13T16/32	QF25	13	$\frac{16}{32}$	0.813	0.897	0.750
QF25SPL13T8/16	QF25	13	$\frac{8}{16}$	1.625	1.794	1.500
QF25SPL14T12/24	QF25	14	$\frac{12}{24}$	1.167	1.283	1.087
QF50SPL13T16/32	QF50	13	$\frac{16}{32}$	0.813	0.897	0.750
QF50SPL13T8/16	QF50	13	$\frac{8}{16}$	1.625	1.794	1.500
QF50SPL14T12/24	QF50	14	$\frac{12}{24}$	1.167	1.283	1.087

Table 52. QUICK FLEX Splined-Hub Dimensions, Continued

Coupling Series	A	C	D1	D2	D3	F	G _{Min}	G _{Max}	H	L1	P	Wt.
	mm in	mm in	mm in	mm in	mm in	mm in	mm in	mm in	mm in	mm in	mm in	kg lbs
QF25	123.4	50.8	106.9	81.0	85.6	46.0	2.83	5.30	60.7	36.1	49.5	4.5
	4.86	2.00	4.21	3.19	3.37	1.81	0.111	0.210	2.39	1.42	1.95	10
QF25	123.4	50.8	106.9	81.0	85.6	46.0	2.83	5.30	60.7	36.1	49.5	4.5
	4.86	2.00	4.21	3.19	3.37	1.81	0.111	0.210	2.39	1.42	1.95	10
QF25	123.4	50.8	106.9	81.0	85.6	46.0	2.83	5.30	60.7	36.1	49.5	4.5
	4.86	2.00	4.21	3.19	3.37	1.81	0.111	0.210	2.39	1.42	1.95	10
QF25	151.4	61.5	139.2	89.4	114.0	54.9	1.81	5.30	75.2	45.2	60.5	7.7
	5.96	2.42	5.48	3.52	4.49	2.16	0.071	0.210	2.96	1.78	2.38	17
QF50	151.4	61.5	139.2	89.4	114.0	54.9	1.81	5.30	75.2	45.2	60.5	7.7
	5.96	2.42	5.48	3.52	4.49	2.16	0.071	0.210	2.96	1.78	2.38	17
QF50	151.4	61.5	139.2	89.4	114.0	54.9	1.81	5.30	75.2	45.2	60.5	7.7
	5.96	2.42	5.48	3.52	4.49	2.16	0.071	0.210	2.96	1.78	2.38	17

Mill-Motor Couplings

Mill-Motor Style Hubs

QUICK FLEX Mill-Motor Style Hubs

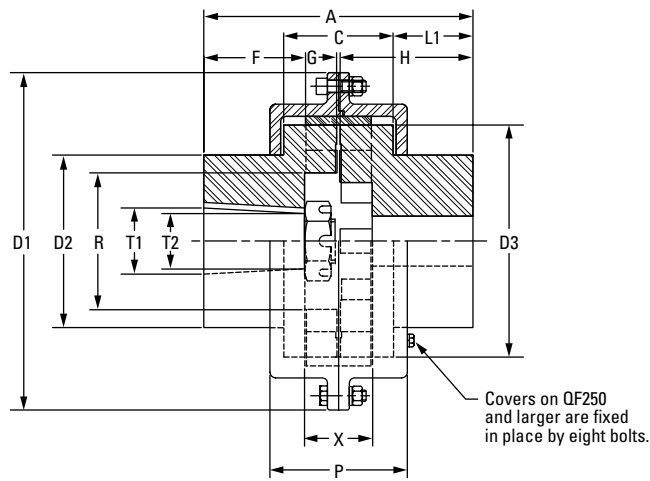

Note: Mill-motor style couplings are available with all cover and insert options.

Fig. 36. QUICK FLEX mill-motor style hubs.

Table 53. QUICK FLEX Mill-Motor Hub Dimensions

Motor Frame Sizes			Coupling	A	C	D1	D2	D3	F	G _{Min}	G _{Max}	H	L1	P	R	T1 ¹	T2 ¹	X	Wt.	
600 Series	800 Series	AC Series		mm	mm	mm	mm	mm	mm	mm	mm	mm	mm	mm	mm	mm	mm	mm	mm	kg
2 602	802 A, B, C	AC 1, 2, 4	QF100 ²	179.6	88.4	227.3	108.0	150.4	62.5	4.35	9.70	86.4	44.7	118.4	77.5	43.00	36.50	55.6	21.3	
				7.07	3.48	8.95	4.25	5.92	2.46	0.171	0.380	3.40	1.76	4.66	3.05	1.694	1.438	2.19	47	
			QF250	213.6	100.6	266.7	147.1	190.0	76.2	4.13	6.60	106.9	59.2	118.6	104.9	44.50	36.50	63.2	36.7	
				8.41	3.96	10.50	5.79	7.48	3.00	0.163	0.258	4.21	2.33	4.67	4.13	1.751	1.438	2.49	81	
603 604	803 804		QF250	216.2	100.6	266.7	147.1	190.0	78.7	4.13	6.60	106.9	59.2	118.6	104.9	49.70	41.50	63.2	36.7	
				8.51	3.96	10.50	5.79	7.48	3.10	0.163	0.258	4.21	2.33	4.67	4.13	1.958	1.635	2.49	81	
			QF500	251.0	118.6	342.9	177.8	235.0	88.9	4.89	9.50	127.0	69.9	149.4	110.2	50.80	41.50	69.9	67.6	
				9.88	4.67	13.50	7.00	9.25	3.50	0.193	0.375	5.00	2.75	5.88	4.34	2.000	1.635	2.75	149	
606	806	AC 8,12	QF250 ²	216.2	100.6	266.7	147.1	190.0	78.7	4.13	6.60	106.9	59.2	118.6	104.9	61.10	52.90	63.2	36.7	
				8.51	3.96	10.50	5.79	7.48	3.10	0.163	0.258	4.21	2.33	4.67	4.13	2.406	2.083	2.49	81	
			QF500	257.3	118.6	342.9	177.8	235.0	95.3	4.89	9.50	127.0	69.9	149.4	110.2	62.80	52.90	69.9	67.6	
				10.13	4.67	13.50	7.00	9.25	3.75	0.193	0.375	5.00	2.75	5.88	4.34	2.474	2.083	2.75	149	
			QF1000	294.4	126.7	387.4	198.4	266.7	101.6	5.65	10.40	152.4	91.4	157.7	157.2	63.50	52.90	77.2	102.5	
				11.59	4.99	15.25	7.81	10.50	4.00	0.223	0.410	6.00	3.60	6.21	6.19	2.500	2.083	3.04	226	
608	808	-	QF500 ²	257.3	118.6	342.9	177.8	235.0	95.3	4.89	9.50	127.0	69.9	149.4	110.2	74.20	64.30	69.9	67.6	
				10.13	4.67	13.50	7.00	9.25	3.75	0.193	0.375	5.00	2.75	5.88	4.34	2.922	2.531	2.75	149	
			QF1000	307.10	126.7	387.4	198.4	266.7	114.3	5.65	10.40	152.4	91.4	157.7	157.2	76.20	64.30	77.2	102.5	
				12.09	4.99	15.25	7.81	10.50	4.50	0.223	0.410	6.00	3.60	6.21	6.19	3.000	2.531	3.04	226	
			QF1890	341.9	150.1	450.9	241.3	325.1	114.3	6.62	11.50	184.4	113.0	185.9	193.0	76.20	64.30	85.1	186.0	
				13.46	5.91	17.75	9.50	12.80	4.50	0.261	0.454	7.26	4.45	7.32	7.60	3.000	2.531	3.35	410	
610	810	AC 18	QF1000	307.1	126.7	387.4	198.4	266.7	114.3	5.65	10.40	152.4	91.4	157.7	155.4	82.60	70.60	77.2	102.5	
				12.09	4.99	15.25	7.81	10.50	4.50	0.223	0.410	6.00	3.60	6.21	6.12	3.250	2.781	3.04	226	
			QF1890	341.9	150.1	450.9	241.3	325.1	114.3	6.62	11.53	184.4	113.0	185.9	193.0	82.60	70.60	85.1	186.0	
				13.46	5.91	17.75	9.50	12.80	4.50	0.261	0.454	7.26	4.45	7.32	7.60	3.250	2.781	3.35	410	
612	812	AC 25,30	QF1000	309.6	126.7	387.4	198.4	266.7	116.8	5.65	10.41	152.4	91.4	157.7	157.2	91.00	78.80	77.2	102.5	
				12.19	4.99	15.25	7.81	10.50	4.60	0.223	0.410	6.00	3.60	6.21	6.19	3.583	3.104	3.04	226	
			QF1890	354.6	150.1	450.9	241.3	325.1	127.0	6.62	11.53	184.4	113.0	185.9	193.0	92.10	78.80	85.1	186.0	
				13.96	5.91	17.75	9.50	12.80	5.00	0.261	0.454	7.26	4.45	7.32	7.60	3.625	3.104	3.35	410	
614	814	AC 40,50	QF1890	354.6	150.1	450.9	241.3	325.1	127.0	6.62	11.53	184.4	113.0	185.9	193.0	108.00	94.70	85.1	186.0	
				13.96	5.91	17.75	9.50	12.80	5.00	0.261	0.454	7.26	4.45	7.32	7.60	4.250	3.729	3.35	410	

Notes: ■ 1 indicates: Standard mill-motor taper (1.25 in per foot on diameter).
 ■ 2 indicates: May need to use standard socket to tighten mill motor nut. Impact socket may not fit.

Notes

Storage of Components

Storage of Components

Lovejoy suggests the following storage guidelines for its coupling components (hereinafter referred to as “products”):

- Unless directed otherwise by Lovejoy, products should be kept in their original packaging until they are ready to be placed into service.
- Do not remove or alter any labels or stencil markings on the packaging.
- Products should be stored in such a way that the packaging is not pierced, crushed or otherwise damaged.
- After a product is removed from its packaging, it should be placed into service as soon as possible.
- When removing a product that is not individually packaged from a bulk pack container, the container should be resealed immediately after the product is removed.
- The relative humidity should be maintained below 60 percent and the surfaces should be dry.
- The storage area should be kept free from airborne contaminants such as, but not limited to, dust, dirt, harmful vapors, etc.
- Extreme conditions of any kind should be avoided.

Inasmuch as Lovejoy is not familiar with a customer’s particular storage conditions, these guidelines are strongly suggested. However, the customer may very well be required by circumstance or applicable government requirements to adhere to stricter storage requirements.

Upon receipt of a product shipment, ensure that the product is not removed from its packaging until it is ready for mounting so that it does not become corroded or contaminated. Product should be stored in an appropriate atmosphere in order that it remains protected for the intended period.

Any questions concerning storage should be directed to your local sales office.

QUICK FLEX® Couplings

Easy-to-install elastomeric couplings designed to withstand harsh conditions.



Better Performance. Less Maintenance.



Lovejoy
2655 Wisconsin Avenue
Downers Grove, IL 60515

630-852-0500
630-852-2120 fax
info@lovejoy-inc.com

www.lovejoy-inc.com

ISO 9001 Certified

Lovejoy® is a registered trademark of Lovejoy.
QUICK FLEX® is a registered trademark of The Timken Company.