

RADIAL AIR BEARING PRODUCT SPECIFICATIONS

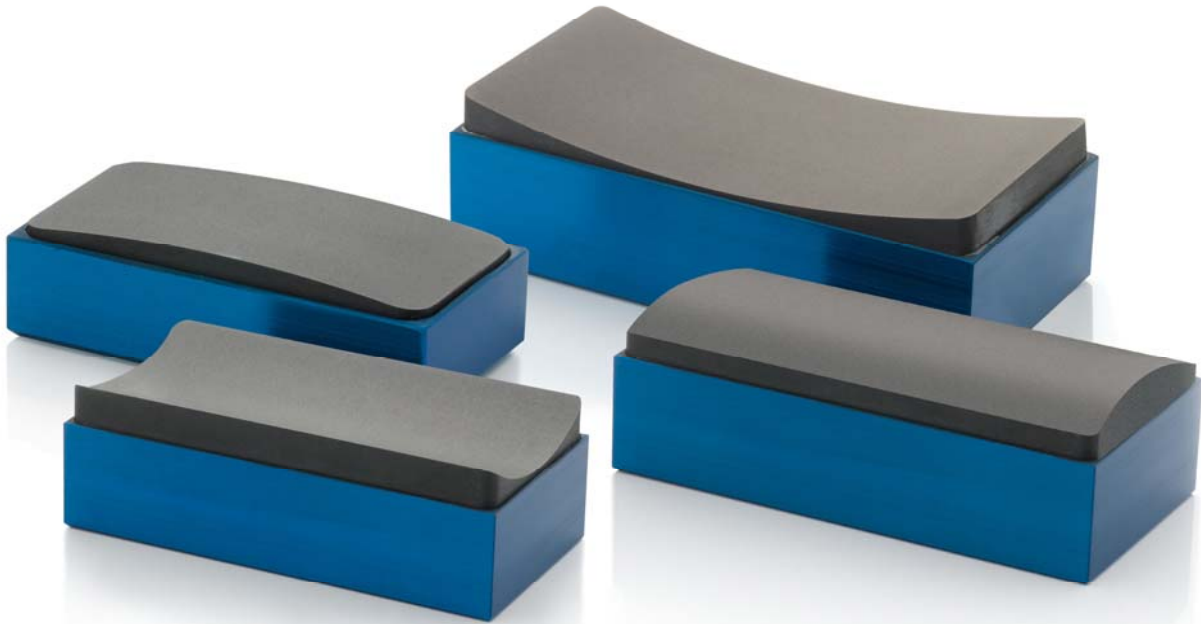

**SPECIFICATIONS AND TOLERANCING INFORMATION
FOR CONCAVE AND CONVEX CONFIGURATIONS**

NEWWAY[®]
air bearings
Frictionless Motion[™]

TABLE OF CONTENTS

RADIAL AIR BEARING LINE INFORMATION

Line Sheet 3

CONCAVE RADIAL AIR BEARING LINE INFORMATION

Dimensions 5
 Specifications 6
 Recommended Width Radius Tolerancing 7
 Recommended Length Radius Tolerancing 8
 Bearing to Shaft Ratio 9
 Effects of Tolerancing Factor Changes 10
 Tolerancing Factor 0.00035 11

CONVEX RADIAL AIR BEARING LINE INFORMATION

Dimensions 12
 Specifications 13
 Recommended Width Radius Tolerancing 14
 Recommended Length Radius Tolerancing 15
 Bearing to Shaft Ratio 16
 Effects of Tolerancing Factor Changes 17
 Tolerancing Factor 0.00035 18

USES AND APPLICATION ILLUSTRATIONS WITH DETAILED DESCRIPTIONS

Rings 19
 Shafts 22
 Large Shafts, Cylinders, Drums 26
 Discs 27



NEWWAY[®]
 air bearings

NEW WAY AIR BEARINGS

POROUS MEDIA AIR BEARING SOLUTIONS™

RADIAL AIR BEARING LINE

patent pending

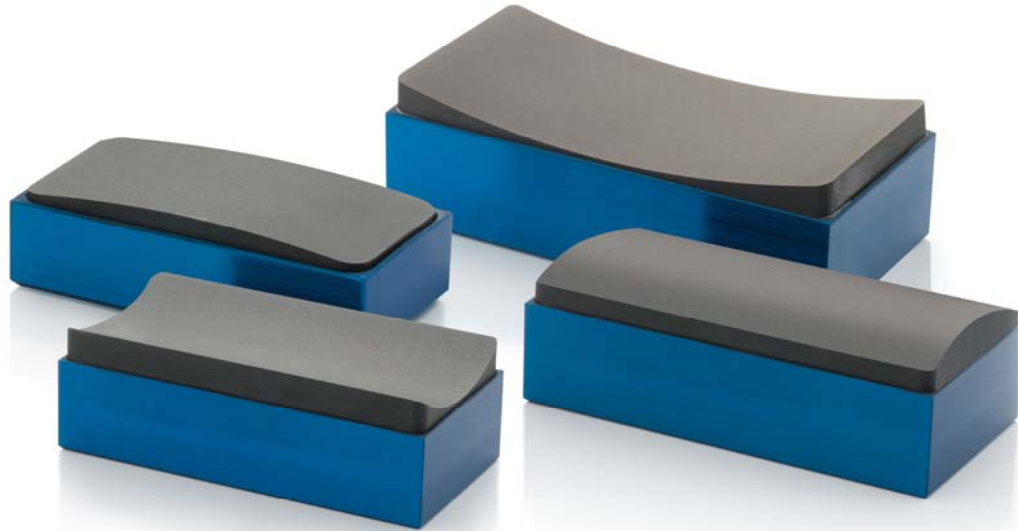

Precision Rotary Motion for Critical Applications

New Way introduces Radial Bearings to its range of Air Bearing products. In either concave or convex configurations, New Way Radial Air Bearings are ideal for rotary applications, giving you all the differential advantages of air bearings that you require: high speed, high precision, no friction, no wear, no need for lubrication, excellent velocity control, and no noise. These porous media air bearings ideal for a wide range of high-performance applications including inspection, imaging, wind power, turbo machinery, powder processing, centrifuge and many others.

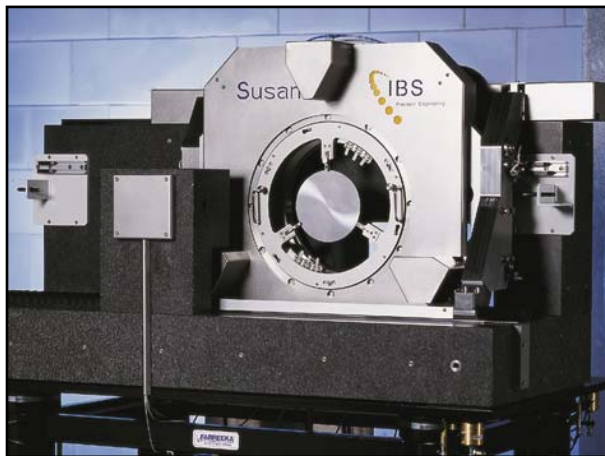

IBS Precision Engineering's Susan Wafer Inspection Machine

Photograph courtesy of IBS Precision Engineering

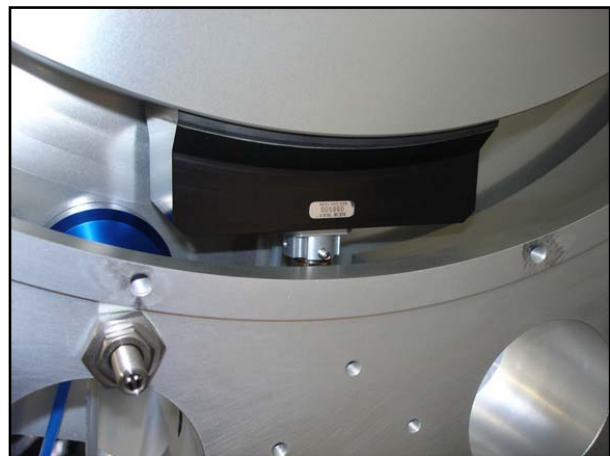

Uses New Way Concave Radial Air Bearings

Photograph courtesy of IBS Precision Engineering

NEWWAY®
air bearings

RADIAL AIR BEARING LINE

Precision Rotary Motion for Critical Applications



Concave Radial Air Bearing Line



Convex Radial Air Bearing Line

Concave Radial Air Bearing Line

Ideal for rotary motion, New Way Concave Porous Media™ Radial Air Bearings are designed to maximize open-ID aperture by enabling you to engineer a supporting structure outside the rotating body.

Convex Radial Air Bearing Line

Ideal for rotary motion, New Way Convex Porous Media™ Radial Air Bearings are designed to minimize the OD circumference, enabling you to engineer a supporting structure inside the rotating body.

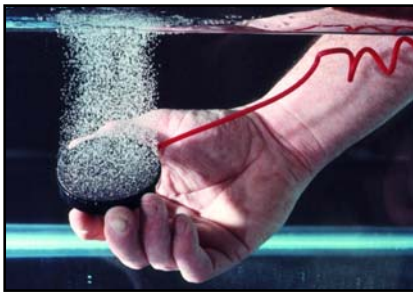

New Way Porous Media™ Technology

The Advantages of Porous Media

Unlike conventional orifice compensation, New Way Porous Media Air Bearings control the airflow across the entire bearing surface. Millions of holes in the porous carbon material produce an ideal supply of uniform air pressure, while simultaneously restricting and damping the air flow. The carbon surface also provides greater bearing protection if there is an air supply failure, and allows the bearings to be moved during air failure without damaging the support surface.

Benefits of New Way Radial Air Bearings

- Large-scale rotary motion
- No contact
- No wear
- No noise
- No touchdown damage
- No need for lubrication
- High speed
- High stiffness
- Averaging of guide surface errors
- Infinite resolution
- Sub-nanometer repeatability
- Excellent velocity control
- No vibration
- Robust
- Inexpensive
- Lower operation cost

NEWWAY[®]
air bearings

50 McDonald Blvd., Aston, PA 19014 USA Phone: 610-494-6700 Fax: 610-494-0911
www.newwayairbearings.com info@newwayairbearings.com

CONCAVE RADIAL AIR BEARINGS

PRODUCT LINE DIMENSIONS

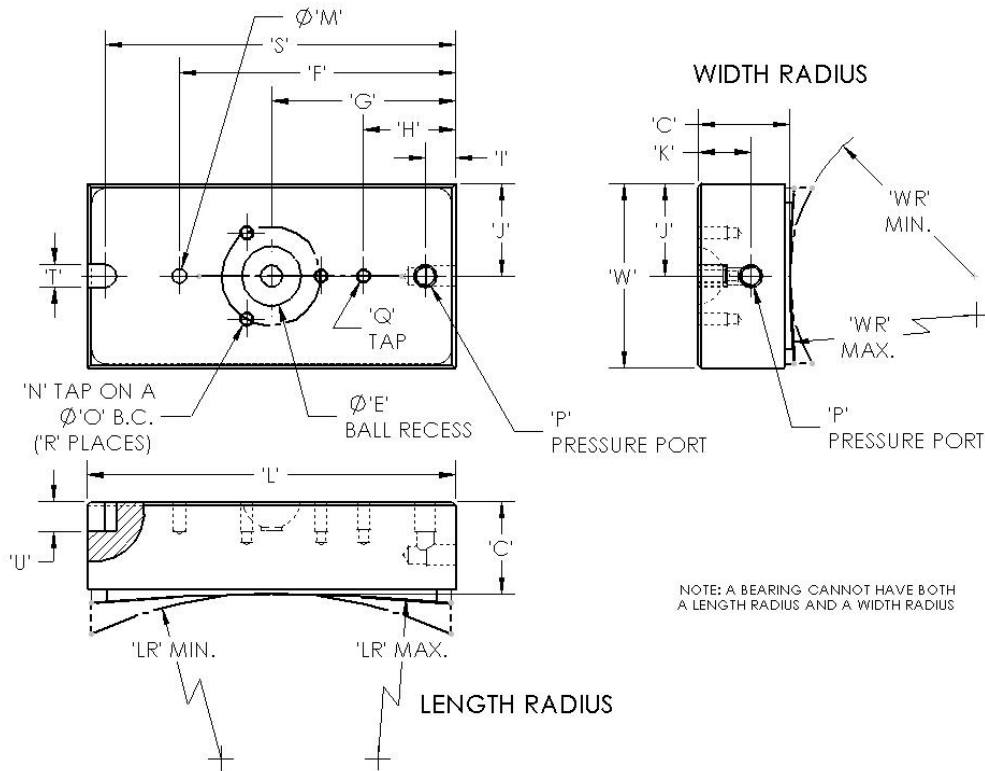

PART NUMBER		DIMENSIONS										
WIDTH RADIUS	LENGTH RADIUS	'W'	'L'	'WR' MIN.	'WR' MAX.	'LR' MIN	'LR' MAX.	'C'	'E'	'F'	'G'	'H'
S3212W***	S3212L***	12	24	12	60	24	120	10	6	N/A	12	N/A
S3215W***	S3215L***	15	30	15	75	30	150	10			15	
S3220W***	S3220L***	20	40	20	100	40	200	13			20	
S3225W***	S3225L***	25	50	25	125	50	250	17	13	59.94	40	20
S3240W***	S3240L***	40	80	40	200	80	400	20			25	
S3250W***	S3250L***	50	100	50	250	100	500	25	25	75	50	25
S3275W***	S3275L***	75	150	75	375	150	750	50		125	75	25
S32100W***	S32100L***	100	200	100	500	200	1000	70		175	100	N/A
S32125W***	S32125L***	125	250	125	625	250	1250	85	225	125		
S32150W***	S32150L***	150	300	150	750	300	1500	100	275	150		

PART NUMBER		DIMENSIONS											
WIDTH RADIUS	LENGTH RADIUS	'I'	'J'	'K'	'M'	'N' TAP	'O'	'P' TAP	'Q' TAP	'R'	'S'	'T'	'U'
S3212W***	S3212L***	N/A	6.0	3.3	N/A	M1.6 X 0.35	10.75	M3 X 0.5	N/A	2	22	2.5	2.5
S3215W***	S3215L***		7.5								28	2.5	2.5
S3220W***	S3220L***		7				10.0	6.3	18.00	37	4.0	4.0	
S3225W***	S3225L***	8	12.5	10.3	3.18	M3 X 0.5	21.59	M5 X 0.8	3	N/A	N/A	N/A	
S3240W***	S3240L***	7.62	20.0	11.5									
S3250W***	S3250L***	8.69	25.0	15.8									
S3275W***	S3275L***	N/A	37.5	36	6.35	M3 X 0.5	38.10	M5 X 0.8	3	N/A	N/A	N/A	
S32100W***	S32100L***	50.0											
S32125W***	S32125L***	25	62.5										
S32150W***	S32150L***	75.0											

NOTES: -*** IN PART NUMBER IS BEARING RADIUS
 -TAP HOLES 'N' QUANTITY OR ORIENTATION MAY NOT BE AS SHOWN ILLUSTRATION

CONCAVE RADIAL AIR BEARINGS

PRODUCT LINE SPECIFICATIONS

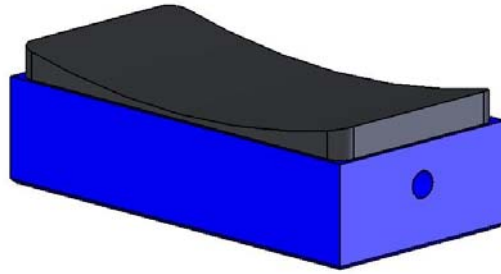

SIZE (MM)	LOAD @ 5 UM FLY HEIGHT (N)	STIFFNESS (N/UM)	FLOW (NLPM)	BALL SOCKET (MM)	BEARING HEIGHT (MM)	BEARING WEIGHT (GM)
12 X 24	22	5	0.40	6	10	6
15 X 30	44	7	1.18	6	10	8
20 X 40	89	14	1.89	6	13	24
25 X 50	156	22	2.36	6	17	48
40 X 80	445	58	4.25	13	20	145
50 X 100	801	110	4.72	13	25	295
75 X 150	1868	250	4.25	25	50	1372
100 X 200	4003	665	4.25	25	70	3628
125 X 250	6672	1009	4.96	25	75	6937
150 X 300	10453	1645	5.19	25	100	11822

NEWWAY[®]
air bearings

50 McDonald Blvd., Aston, PA 19014 USA
www.newwayairbearings.com

Phone: 610.494.6700 Fax: 610.494.0911
info@newwayairbearings.com

CONCAVE RADIAL AIR BEARINGS

RECOMMENDED WIDTH RADIUS TOLERANCING

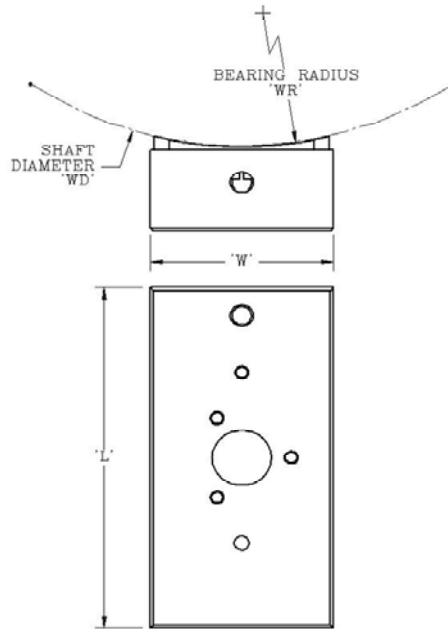

BEARING SIZE		MINIMUM RECOMMENDED SIZE		MAXIMUM RECOMMENDED SIZE	
'W'	'L'	SHAFT DIAMETER	BEARING RADIUS	SHAFT DIAMETER	BEARING RADIUS
		('WD' MIN.= 'W' X 2)	('WR' MIN.= 'W' X 1)	('WD' MAX.= 'W' X 10)	('WR' MAX.= 'W' X 5)
		'WD' MIN.	'WR' MIN.	'WD' MAX.	'WR' MAX.
12	24	24 + 0.0000 - 0.0084	12 + 0.0042 - 0.0000	120 + 0.0000 - 0.0420	60 + 0.0210 - 0.0000
15	30	30 + 0.0000 - 0.0105	15 + 0.0053 - 0.0000	150 + 0.0000 - 0.0525	75 + 0.0263 - 0.0000
20	40	40 + 0.0000 - 0.0140	20 + 0.0070 - 0.0000	200 + 0.0000 - 0.0700	100 + 0.0350 - 0.0000
25	50	50 + 0.0000 - 0.0175	25 + 0.0088 - 0.0000	250 + 0.0000 - 0.0875	125 + 0.0438 - 0.0000
40	80	80 + 0.0000 - 0.0280	40 + 0.0140 - 0.0000	400 + 0.0000 - 0.1400	200 + 0.0700 - 0.0000
50	100	100 + 0.0000 - 0.0350	50 + 0.0175 - 0.0000	500 + 0.0000 - 0.1750	250 + 0.0875 - 0.0000
75	150	150 + 0.0000 - 0.0525	75 + 0.0263 - 0.0000	750 + 0.0000 - 0.2625	375 + 0.1313 - 0.0000
100	200	200 + 0.0000 - 0.0700	100 + 0.0350 - 0.0000	1000 + 0.0000 - 0.3500	500 + 0.1750 - 0.0000
125	250	250 + 0.0000 - 0.0875	125 + 0.0438 - 0.0000	1250 + 0.0000 - 0.4375	625 + 0.2188 - 0.0000
150	300	300 + 0.0000 - 0.1050	150 + 0.0525 - 0.0000	1500 + 0.0000 - 0.5250	750 + 0.2625 - 0.0000

NOTES: -ALL DIMENSIONS ARE IN MILLIMETERS

-RECOMMENDED TOLERANCING FACTOR ('TF'): 0.00035

-TO CALCULATE TOLERANCE FOR SPECIFIC SHAFT SIZE ('WD'):

$$\text{SHAFT DIAMETER TOLERANCE} = \frac{+ 0.0000}{- 'WD' \times 'TF'}$$

$$\text{BEARING RADIUS TOLERANCE} = \frac{+ ('WD' / 2) \times 'TF'}{- 0.0000}$$

-THE TOLERANCING FACTOR MAY BE INCREASED OR DECREASED AS REQUIRED. CONSULT FACTORY FOR MORE INFORMATION

50 McDonald Blvd., Aston, PA 19014 USA
www.newwayairbearings.com

NEWWAY[®]
air bearings

Phone: 610.494.6700 Fax: 610.494.0911
info@newwayairbearings.com

CONCAVE RADIAL AIR BEARINGS

RECOMMENDED LENGTH RADIUS TOLERANCING

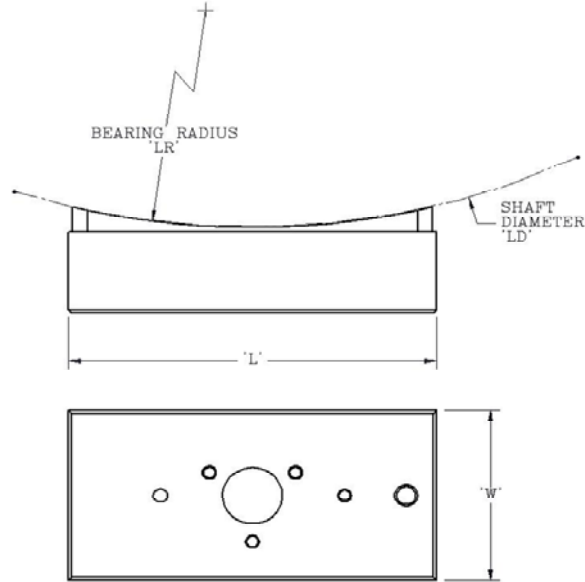

NEWWAY air bearings		MINIMUM RECOMMENDED SIZE ('L' X 1)		MAXIMUM RECOMMENDED SIZE ('L' X 5)	
BEARING SIZE		SHAFT DIAMETER		SHAFT DIAMETER	
'W'	'L'	('LD' MIN.= 'L' X 2)		('LD' MAX.= 'L' X 10)	
		'LD' MIN.	'LR' MIN.	'LD' MAX.	'LR' MAX.
12	24	48 + 0.0000 - 0.0168	24 + 0.0084 - 0.0000	240 + 0.0000 - 0.0840	120 + 0.0420 - 0.0000
15	30	60 + 0.0000 - 0.0210	30 + 0.0105 - 0.0000	300 + 0.0000 - 0.1050	150 + 0.0525 - 0.0000
20	40	80 + 0.0000 - 0.0280	40 + 0.0140 - 0.0000	400 + 0.0000 - 0.1400	200 + 0.0700 - 0.0000
25	50	100 + 0.0000 - 0.0350	50 + 0.0175 - 0.0000	500 + 0.0000 - 0.1750	250 + 0.0875 - 0.0000
40	80	160 + 0.0000 - 0.0560	80 + 0.0280 - 0.0000	800 + 0.0000 - 0.2800	400 + 0.1400 - 0.0000
50	100	200 + 0.0000 - 0.0700	100 + 0.0350 - 0.0000	1000 + 0.0000 - 0.3500	500 + 0.1750 - 0.0000
75	150	300 + 0.0000 - 0.1050	150 + 0.0525 - 0.0000	1500 + 0.0000 - 0.5250	750 + 0.2625 - 0.0000
100	200	400 + 0.0000 - 0.1400	200 + 0.0700 - 0.0000	2000 + 0.0000 - 0.7000	1000 + 0.3500 - 0.0000
125	250	500 + 0.0000 - 0.1750	250 + 0.0875 - 0.0000	2500 + 0.0000 - 0.8750	1250 + 0.4375 - 0.0000
150	300	600 + 0.0000 - 0.2100	300 + 0.1050 - 0.0000	3000 + 0.0000 - 1.0500	1500 + 0.5250 - 0.0000

NOTES: -ALL DIMENSIONS ARE IN MILLIMETERS

-RECOMMENDED TOLERANCING FACTOR ('TF'): 0.00035

-TO CALCULATE TOLERANCE FOR SPECIFIC SHAFT SIZE ('LD'):

$$\text{SHAFT DIAMETER TOLERANCE} = \frac{+ 0.0000}{- 'LD' \times 'TF'}$$

$$\text{BEARING RADIUS TOLERANCE} = \frac{+ ('LD' / 2) \times 'TF'}{- 0.0000}$$

-THE TOLERANCING FACTOR MAY BE INCREASED OR DECREASED AS REQUIRED. CONSULT FACTORY FOR MORE INFORMATION

NEWWAY[®]
air bearings

50 McDonald Blvd., Aston, PA 19014 USA
www.newwayairbearings.com

Phone: 610.494.6700 Fax: 610.494.0911
info@newwayairbearings.com

CONCAVE RADIAL AIR BEARINGS

BEARING TO SHAFT RATIO

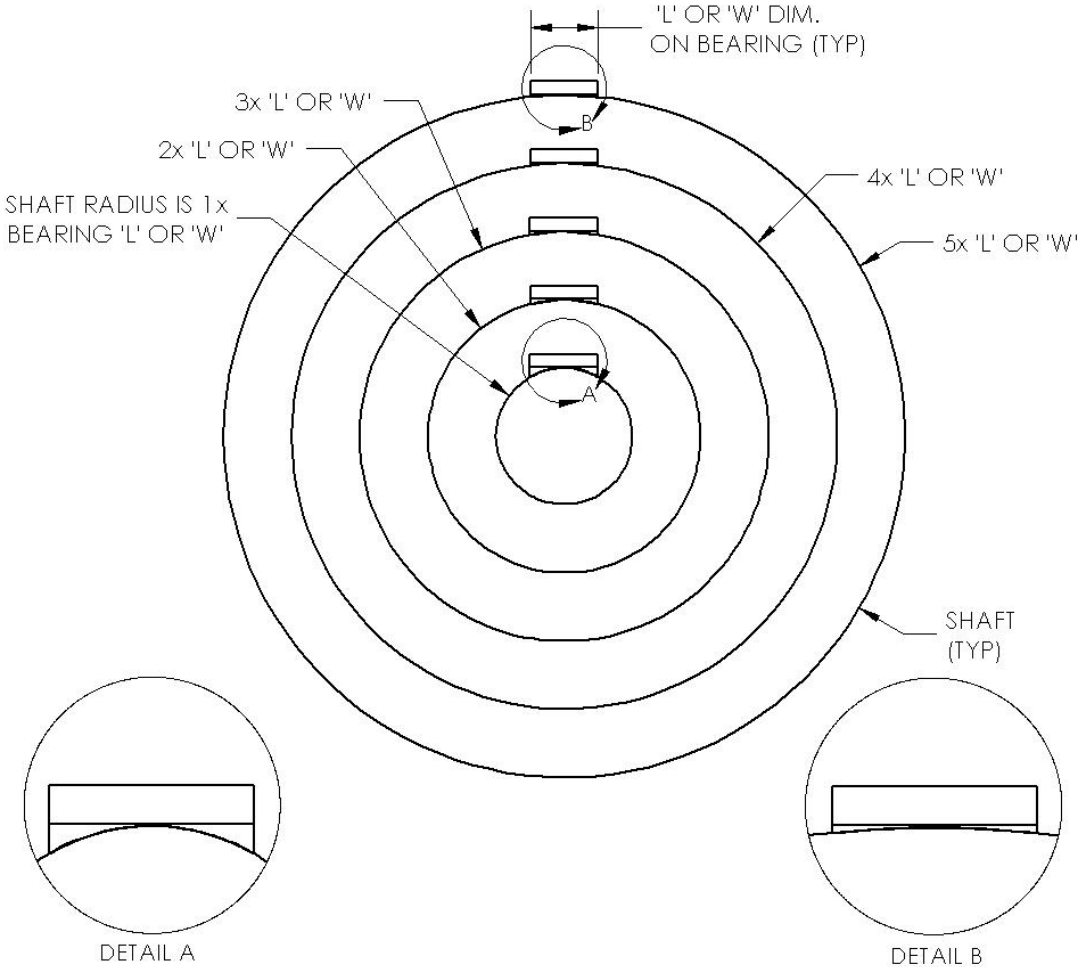

CONCAVE RADIAL AIR BEARINGS

EFFECTS OF TOLERANCING FACTOR CHANGES

The Tolerancing Factor is used to generate the manufacturing tolerances for the shaft diameter and bearing radius. The table below illustrates the effect of changes in the tolerancing factor to the gaps at the ends of the radial bearing under worst-case conditions.

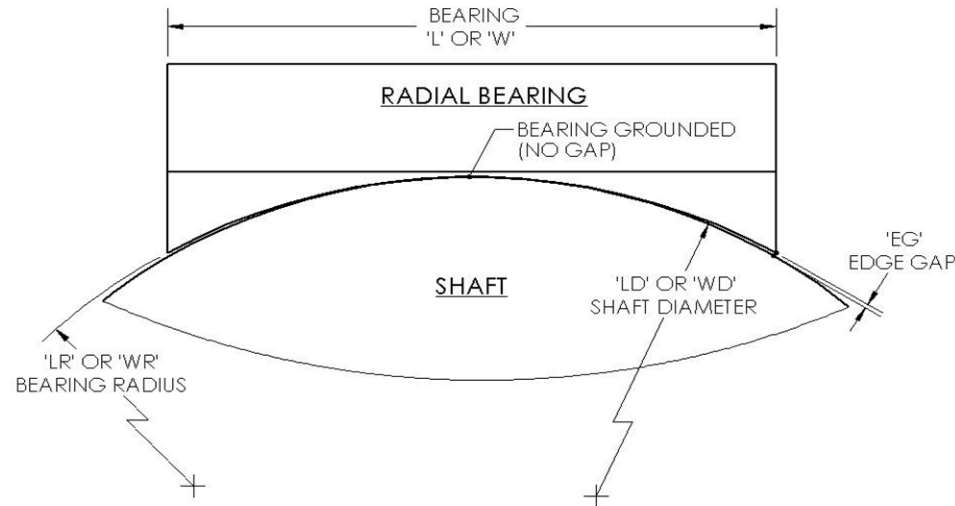

SMALLEST BEARING SIZE

TOLERANCING FACTOR	BEARING WIDTH	SHAFT DIAMETER	BEARING RADIUS	EDGE GAP
'TF'	'W'	'WD'	'WR'	'EG'
0.00010	12	23.9976	12.0012	0.00032
0.00015		23.9964	12.0018	0.00048
0.00020		23.9952	12.0024	0.00064
0.00025		23.9940	12.0030	0.00080
0.00030		23.9928	12.0036	0.00096
0.00035		23.9916	12.0042	0.00113
0.00040		23.9904	12.0048	0.00129
0.00045		23.9892	12.0054	0.00145
0.00050		23.9880	12.0060	0.00161

LARGEST BEARING SIZE

TOLERANCING FACTOR	BEARING LENGTH	SHAFT DIAMETER	BEARING RADIUS	EDGE GAP
'TF'	'L'	'LD'	'LR'	'EG'
0.00010	300	599.9400	300.0300	0.00804
0.00015		599.9100	300.0450	0.01206
0.00020		599.8800	300.0600	0.01608
0.00025		599.8500	300.0750	0.02009
0.00030		599.8200	300.0900	0.02411
0.00035		599.7900	300.1050	0.02813
0.00040		599.7600	300.1200	0.03215
0.00045		599.7300	300.1350	0.03617
0.00050		599.7000	300.1500	0.04019

NOTES: -ALL DIMENSIONS ARE IN MILLIMETERS

-FOR ANY GIVEN BEARING SIZE AND TOLERANCING FACTOR, THE EDGE GAP ('EG') DIMENSION WILL INCREASE AS THE SHAFT DIAMETER DECREASES. IN THE TABLE ABOVE THE NOMINAL SHAFT DIAMETER IS THE MINIMUM DIAMETER RECOMMENDED FOR USE WITH THE CHOSEN BEARING SIZE.

-SHAFT DIAMETERS 'WD' AND 'LD' ARE THE MINIMUM SIZE ALLOWED FOR EACH GIVEN TOLERANCING FACTOR

-BEARING RADIUS 'WR' AND 'LR' ARE THE MAXIMUM SIZE ALLOWED FOR EACH GIVEN TOLERANCING FACTOR

50 McDonald Blvd., Aston, PA 19014 USA
www.newwayairbearings.com

NEWWAY[®]
air bearings

Phone: 610.494.6700 Fax: 610.494.0911
info@newwayairbearings.com

CONCAVE RADIAL AIR BEARINGS

TOLERANCING FACTOR = 0.00035

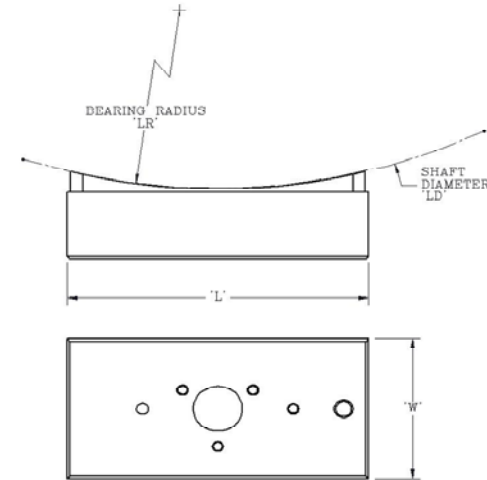
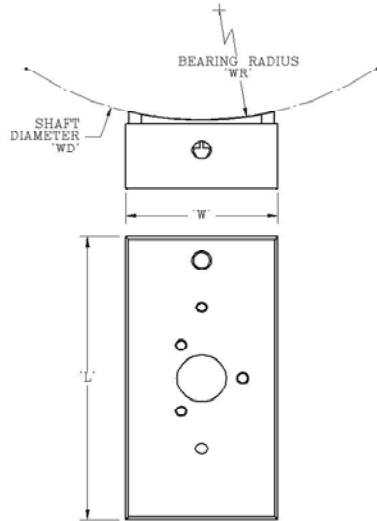

BEARING SIZE		MINIMUM RECOMMENDED SIZE		MAXIMUM RECOMMENDED SIZE	
'W'	'L'	SHAFT DIAMETER	BEARING RADIUS	SHAFT DIAMETER	BEARING RADIUS
		('WD' MIN.= 'W' X 2)	(WR MIN.= 'W' X 1)	('WD' MAX.= 'W' X 10)	('WR' MAX.= 'W' X 5)
		'WD' MIN.	'WR' MIN.	'WD' MAX.	'WR' MAX.
12	24	24 +0.0000 -0.0084	12 +0.0042 -0.0000	120 +0.0000 -0.0420	60 +0.0210 -0.0000
15	30	30 +0.0000 -0.0105	15 +0.0053 -0.0000	150 +0.0000 -0.0525	75 +0.0263 -0.0000
20	40	40 +0.0000 -0.0140	20 +0.0070 -0.0000	200 +0.0000 -0.0700	100 +0.0350 -0.0000
25	50	50 +0.0000 -0.0175	25 +0.0088 -0.0000	250 +0.0000 -0.0875	125 +0.0438 -0.0000
40	80	80 +0.0000 -0.0280	40 +0.0140 -0.0000	400 +0.0000 -0.1400	200 +0.0700 -0.0000
50	100	100 +0.0000 -0.0350	50 +0.0175 -0.0000	500 +0.0000 -0.1750	250 +0.0875 -0.0000
75	150	150 +0.0000 -0.0525	75 +0.0263 -0.0000	750 +0.0000 -0.2625	375 +0.1313 -0.0000
100	200	200 +0.0000 -0.0700	100 +0.0350 -0.0000	1000 +0.0000 -0.3500	500 +0.1750 -0.0000
125	250	250 +0.0000 -0.0875	125 +0.0438 -0.0000	1250 +0.0000 -0.4375	625 +0.2188 -0.0000
150	300	300 +0.0000 -0.1050	150 +0.0525 -0.0000	1500 +0.0000 -0.5250	750 +0.2625 -0.0000

NOTES: -ALL DIMENSIONS ARE IN MILLIMETERS
-TOLERANCING FACTOR ('TF'): 0.00035

BEARING SIZE		MINIMUM RECOMMENDED SIZE ('L' X 1)		MAXIMUM RECOMMENDED SIZE ('L' X 5)	
'W'	'L'	SHAFT DIAMETER	BEARING RADIUS	SHAFT DIAMETER	BEARING RADIUS
		('LD' MIN.= 'L' X 2)	(LR MIN.= 'L' X 1)	('LD' MAX.= 'L' X 10)	('LR' MAX.= 'L' X 5)
		'LD' MIN.	'LR' MIN.	'LD' MAX.	'LR' MAX.
12	24	48 +0.0000 -0.0168	24 +0.0084 -0.0000	240 +0.0000 -0.0840	120 +0.0420 -0.0000
15	30	60 +0.0000 -0.0210	30 +0.0105 -0.0000	300 +0.0000 -0.1050	150 +0.0525 -0.0000
20	40	80 +0.0000 -0.0280	40 +0.0140 -0.0000	400 +0.0000 -0.1400	200 +0.0700 -0.0000
25	50	100 +0.0000 -0.0350	50 +0.0175 -0.0000	500 +0.0000 -0.1750	250 +0.0875 -0.0000
40	80	160 +0.0000 -0.0560	80 +0.0280 -0.0000	800 +0.0000 -0.2800	400 +0.1400 -0.0000
50	100	200 +0.0000 -0.0700	100 +0.0350 -0.0000	1000 +0.0000 -0.3500	500 +0.1750 -0.0000
75	150	300 +0.0000 -0.1050	150 +0.0525 -0.0000	1500 +0.0000 -0.5250	750 +0.2625 -0.0000
100	200	400 +0.0000 -0.1400	200 +0.0700 -0.0000	2000 +0.0000 -0.7000	1000 +0.3500 -0.0000
125	250	500 +0.0000 -0.1750	250 +0.0875 -0.0000	2500 +0.0000 -0.8750	1250 +0.4375 -0.0000
150	300	600 +0.0000 -0.2100	300 +0.1050 -0.0000	3000 +0.0000 -1.0500	1500 +0.5250 -0.0000

NOTES: -ALL DIMENSIONS ARE IN MILLIMETERS
-TOLERANCING FACTOR ('TF'): 0.00035

50 McDonald Blvd., Aston, PA 19014 USA
www.newwayairbearings.com



Phone: 610.494.6700 Fax: 610.494.0911
info@newwayairbearings.com

CONVEX RADIAL AIR BEARINGS

PRODUCT LINE DIMENSIONS

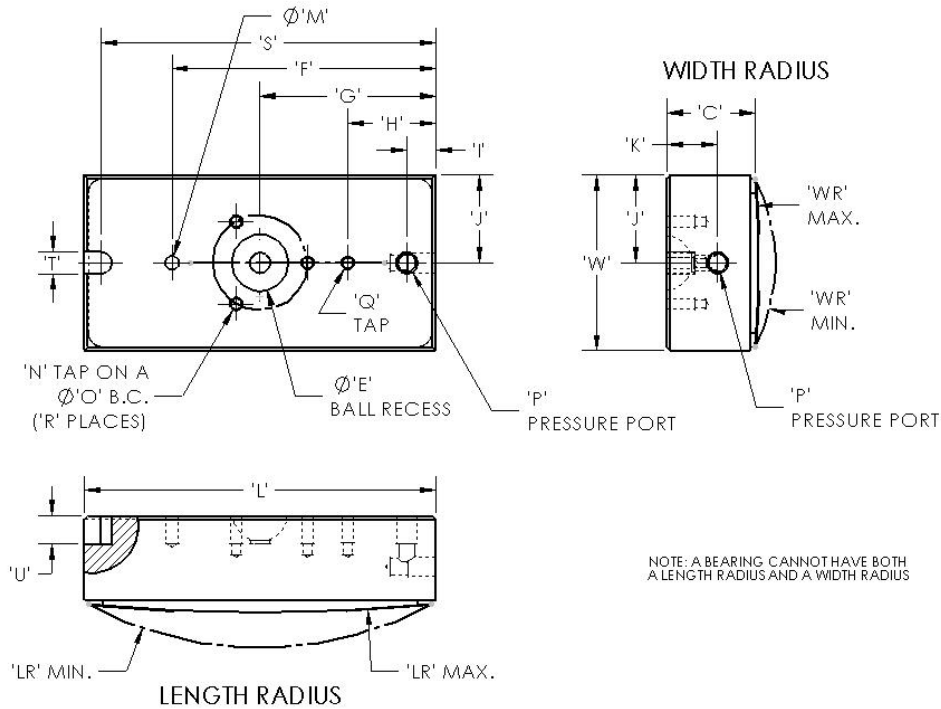

NOTE: A BEARING CANNOT HAVE BOTH A LENGTH RADIUS AND A WIDTH RADIUS

PART NUMBER		DIMENSIONS											
WIDTH RADIUS	LENGTH RADIUS	'W'	'L'	'WR' MIN.	'WR' MAX.	'LR' MIN	'LR' MAX.	'C'	'E'	'F'	'G'	'H'	
S3312W***	S3312L***	12	24	12	60	24	120	10	6	N/A	12	N/A	
S3315W***	S3315L***	15	30	15	75	30	150	10			15		
S3320W***	S3320L***	20	40	20	100	40	200	13			20		
S3325W***	S3325L***	25	50	25	125	50	250	17	13	25	20		
S3340W***	S3340L***	40	80	40	200	80	400	20		59.94		40	
S3350W***	S3350L***	50	100	50	250	100	500	25		75		50	25
S3375W***	S3375L***	75	150	75	375	150	750	50	25	125	75	25	
S33100W***	S33100L***	100	200	100	500	200	1000	70		175	100		
S33125W***	S33125L***	125	250	125	625	250	1250	85		225	125	N/A	
S33150W***	S33150L***	150	300	150	750	300	1500	100	275	150	N/A		

PART NUMBER		DIMENSIONS											
WIDTH RADIUS	LENGTH RADIUS	'I'	'J'	'K'	'M'	'N' TAP	'O'	'P' TAP	'Q' TAP	'R'	'S'	'T'	'U'
S3312W***	S3312L***	N/A	6.0	3.3	N/A	M1.6 X 0.35	10.75	M3 X 0.5	N/A	2	22	2.5	2.5
S3315W***	S3315L***		7.5	3.3			18.00				28	2.5	2.5
S3320W***	S3320L***		7	10.0			6.3				37	4.0	4.0
S3325W***	S3325L***	8	12.5	10.3	3.175	M3 X 0.5	21.59	M3 X 0.5	4	47	4.0	4.0	
S3340W***	S3340L***	7.62	20.0	11.5									
S3350W***	S3350L***	8.69	25.0	15.8									
S3375W***	S3375L***	N/A	37.5	3.175	6.35	M3 X 0.5	38.10	M5 X 0.8	3	N/A	N/A	N/A	
S33100W***	S33100L***	50.0											
S33125W***	S33125L***	62.5											
S33150W***	S33150L***	75.0											

NOTES: -*** IN PART NUMBER IS BEARING RADIUS

-TAP HOLES 'N' QUANTITY OR ORIENTATION MAY NOT BE AS SHOWN ILLUSTRATION

NEWWAY[®]
air bearings

50 McDonald Blvd., Aston, PA 19014 USA
www.newwayairbearings.com

Phone: 610.494.6700 Fax: 610.494.0911
info@newwayairbearings.com

CONVEX RADIAL AIR BEARINGS

PRODUCT LINE SPECIFICATIONS

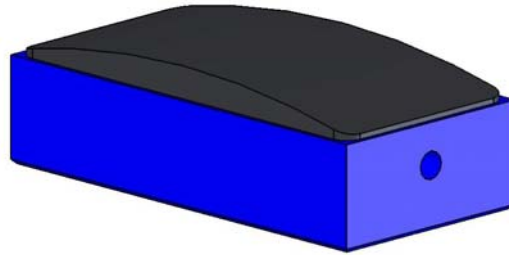

SIZE (MM)	LOAD @ 5 UM FLY HEIGHT (N)	STIFFNESS (N/UM)	FLOW (NLPM)	BALL SOCKET (MM)	BEARING HEIGHT (MM)	BEARING WEIGHT (GM)
12 X 24	22	5	0.40	6	10	6
15 X 30	44	7	1.18	6	10	8
20 X 40	89	14	1.89	6	13	24
25 X 50	156	22	2.36	6	17	48
40 X 80	445	58	4.25	13	20	145
50 X 100	801	110	4.72	13	25	295
75 X 150	1868	250	4.25	25	50	1372
100 X 200	4003	665	4.25	25	70	3628
125 X 250	6672	1009	4.96	25	75	6937
150 X 300	10453	1645	5.19	25	100	11822

50 McDonald Blvd., Aston, PA 19014 USA
www.newwayairbearings.com

NEWWAY[®]
 air bearings

Phone: 610.494.6700 Fax: 610.494.0911
info@newwayairbearings.com

CONVEX RADIAL AIR BEARINGS

RECOMMENDED WIDTH RADIUS TOLERANCING

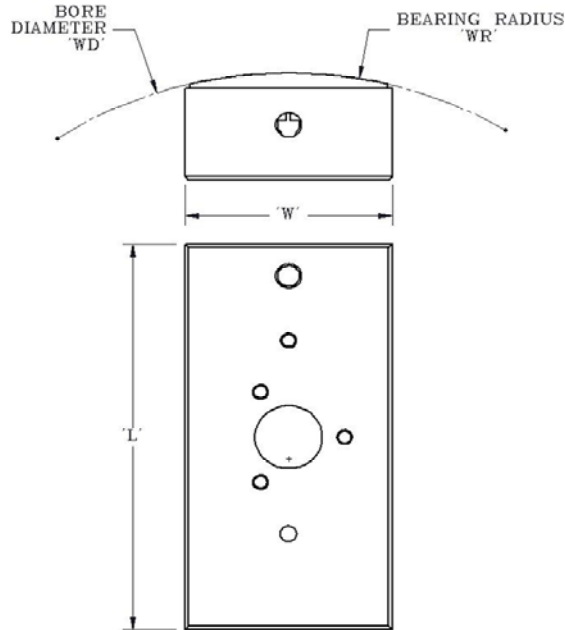

NEWWAY [®] air bearings		MINIMUM RECOMMENDED SIZE		MAXIMUM RECOMMENDED SIZE	
'W'	'L'	BORE DIAMETER		BEARING RADIUS	
		('WD' MIN. = 'W' X 2)		(WR MIN. = 'W' X 1)	
		'WD' MIN.	'WR' MIN.	'WD' MAX.	'WR' MAX.
12	24	24 + 0.0084 - 0.0000	12 + 0.0000 - 0.0042	120 + 0.0420 - 0.0000	60 + 0.0000 - 0.0210
15	30	30 + 0.0105 - 0.0000	15 + 0.0000 - 0.0053	150 + 0.0525 - 0.0000	75 + 0.0000 - 0.0263
20	40	40 + 0.0140 - 0.0000	20 + 0.0000 - 0.0070	200 + 0.0700 - 0.0000	100 + 0.0000 - 0.0350
25	50	50 + 0.0175 - 0.0000	25 + 0.0000 - 0.0088	250 + 0.0875 - 0.0000	125 + 0.0000 - 0.0438
40	80	80 + 0.0280 - 0.0000	40 + 0.0000 - 0.0140	400 + 0.1400 - 0.0000	200 + 0.0000 - 0.0700
50	100	100 + 0.0350 - 0.0000	50 + 0.0000 - 0.0175	500 + 0.1750 - 0.0000	250 + 0.0000 - 0.0875
75	150	150 + 0.0525 - 0.0000	75 + 0.0000 - 0.0263	750 + 0.2625 - 0.0000	375 + 0.0000 - 0.1313
100	200	200 + 0.0700 - 0.0000	100 + 0.0000 - 0.0350	1000 + 0.3500 - 0.0000	500 + 0.0000 - 0.1750
125	250	250 + 0.0875 - 0.0000	125 + 0.0000 - 0.0438	1250 + 0.4375 - 0.0000	625 + 0.0000 - 0.2188
150	300	300 + 0.1050 - 0.0000	150 + 0.0000 - 0.0525	1500 + 0.5250 - 0.0000	750 + 0.0000 - 0.2625

NOTES: -ALL DIMENSIONS ARE IN MILLIMETERS

-RECOMMENDED TOLERANCING FACTOR ('TF'): 0.00035

-TO CALCULATE TOLERANCE FOR SPECIFIC BORE SIZE ('WD'):

$$\text{BORE DIAMETER TOLERANCE} = \frac{+ 'WD' \times 'TF'}{- 0.0000}$$

$$\text{BEARING RADIUS TOLERANCE} = \frac{+ 0.0000}{- ('WD' / 2) \times 'TF'}$$

-THE TOLERANCING FACTOR MAY BE INCREASED OR DECREASED AS REQUIRED. CONSULT FACTORY FOR MORE INFORMATION

CONVEX RADIAL AIR BEARINGS

RECOMMENDED LENGTH RADIUS TOLERANCING

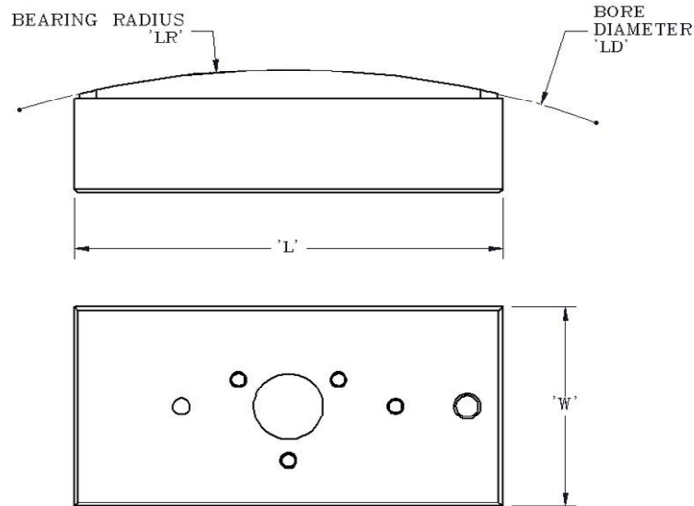

NEWWAY air bearings		MINIMUM RECOMMENDED SIZE ('L' X 1)		MAXIMUM RECOMMENDED SIZE ('L' X 5)	
BEARING SIZE		BORE DIAMETER		BORE DIAMETER	
		('LD' MIN.= 'L' X 2)		('LD' MAX.= 'L' X 10)	
'W'	'L'	'LD' MIN.	'LR' MIN.	'LD' MAX.	'LR' MAX.
12	24	48 + 0.0168 - 0.0000	24 + 0.0000 - 0.0084	240 + 0.0840 - 0.0000	120 + 0.0000 - 0.0420
15	30	60 + 0.0210 - 0.0000	30 + 0.0000 - 0.0105	300 + 0.1050 - 0.0000	150 + 0.0000 - 0.0525
20	40	80 + 0.0280 - 0.0000	40 + 0.0000 - 0.0140	400 + 0.1400 - 0.0000	200 + 0.0000 - 0.0700
25	50	100 + 0.0350 - 0.0000	50 + 0.0000 - 0.0175	500 + 0.1750 - 0.0000	250 + 0.0000 - 0.0875
40	80	160 + 0.0560 - 0.0000	80 + 0.0000 - 0.0280	800 + 0.2800 - 0.0000	400 + 0.0000 - 0.1400
50	100	200 + 0.0700 - 0.0000	100 + 0.0000 - 0.0350	1000 + 0.3500 - 0.0000	500 + 0.0000 - 0.1750
75	150	300 + 0.1050 - 0.0000	150 + 0.0000 - 0.0525	1500 + 0.5250 - 0.0000	750 + 0.0000 - 0.2625
100	200	400 + 0.1400 - 0.0000	200 + 0.0000 - 0.0700	2000 + 0.7000 - 0.0000	1000 + 0.0000 - 0.3500
125	250	500 + 0.1750 - 0.0000	250 + 0.0000 - 0.0875	2500 + 0.8750 - 0.0000	1250 + 0.0000 - 0.4375
150	300	600 + 0.2100 - 0.0000	300 + 0.0000 - 0.1050	3000 + 1.0500 - 0.0000	1500 + 0.0000 - 0.5250

NOTES: -ALL DIMENSIONS ARE IN MILLIMETERS

-RECOMMENDED TOLERANCING FACTOR ('TF'): 0.00035

-TO CALCULATE TOLERANCE FOR SPECIFIC BORE SIZE ('LD'):

$$\text{BORE DIAMETER TOLERANCE} = \frac{+ 0.0000}{- 'LD' \times 'TF'}$$

$$\text{BEARING RADIUS TOLERANCE} = \frac{+ ('LD' / 2) \times 'TF'}{- 0.0000}$$

-THE TOLERANCING FACTOR MAY BE INCREASED OR DECREASED AS REQUIRED. CONSULT FACTORY FOR MORE INFORMATION

NEWWAY[®]
air bearings

50 McDonald Blvd., Aston, PA 19014 USA
www.newwayairbearings.com

Phone: 610.494.6700 Fax: 610.494.0911
info@newwayairbearings.com

CONVEX RADIAL AIR BEARINGS

BEARING TO BORE RATIO

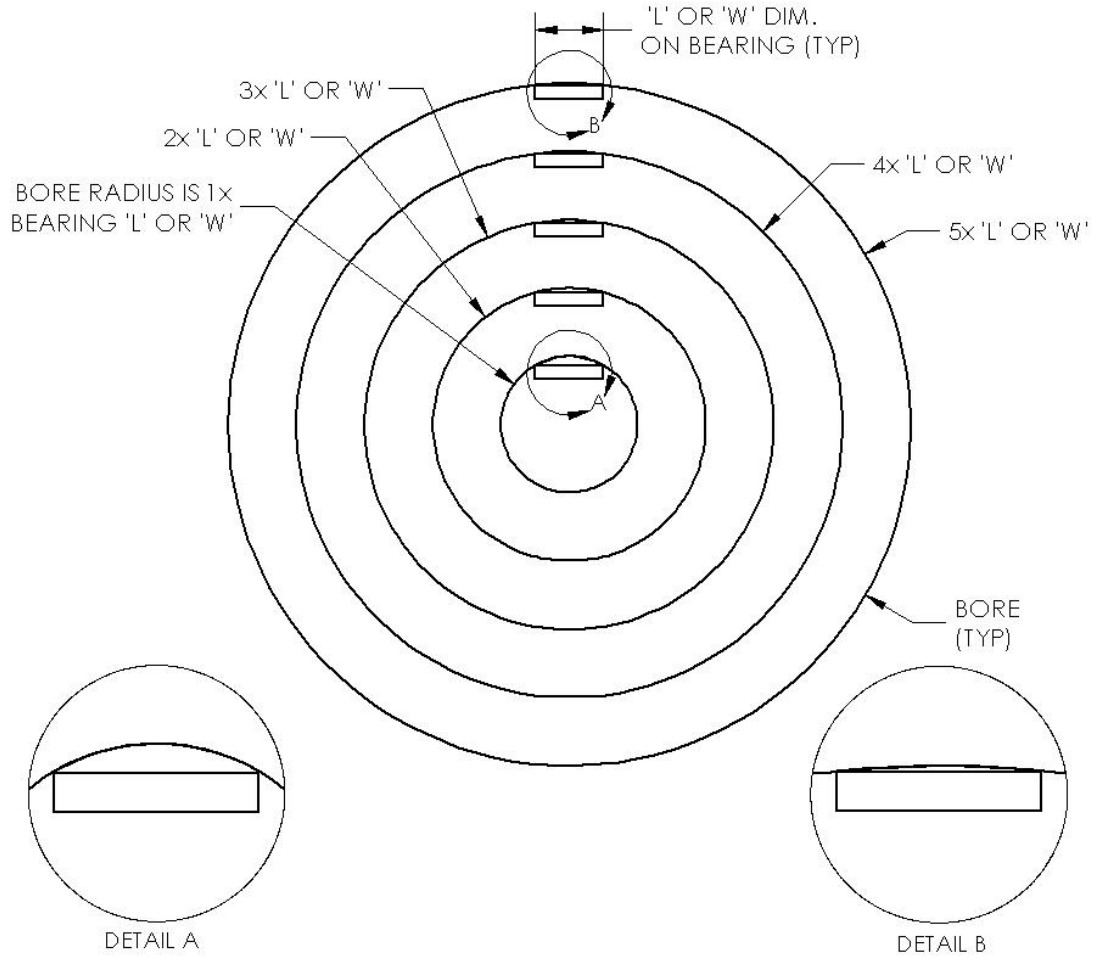

CONVEX RADIAL AIR BEARINGS

EFFECTS OF TOLERANCING FACTOR CHANGES

The Tolerancing Factor is used to generate the manufacturing tolerances for the bore diameter and bearing radius. The table below illustrates the effect of changes in the tolerancing factor to the gaps at the ends of the radial bearing under worst-case conditions.

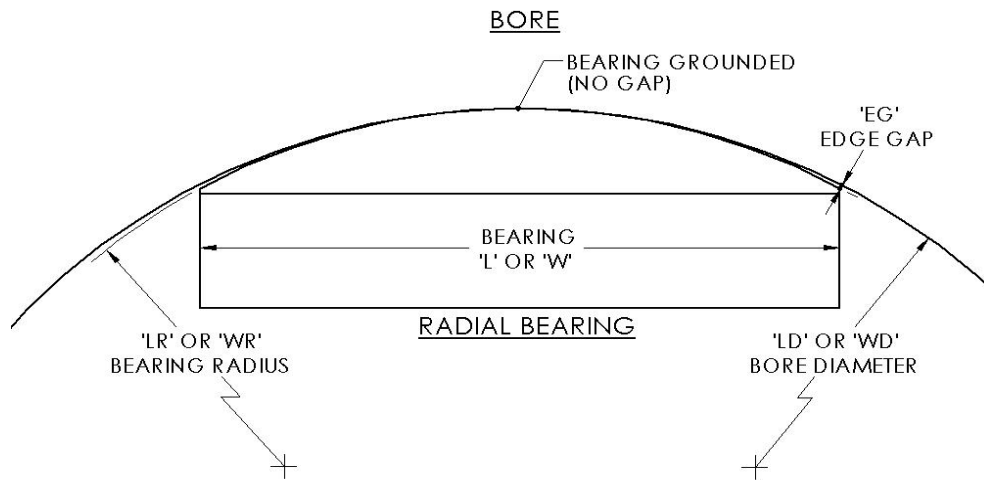

SMALLEST BEARING SIZE

TOLERANCING FACTOR	BEARING WIDTH	BORE DIAMETER	BEARING RADIUS	EDGE GAP
'TF'	'W'	'WD'	'WR'	'EG'
0.00010	12	24.0024	11.9988	0.00032
0.00015		24.0036	11.9982	0.00048
0.00020		24.0048	11.9976	0.00064
0.00025		24.0060	11.9970	0.00080
0.00030		24.0072	11.9964	0.00096
0.00035		24.0084	11.9958	0.00113
0.00040		24.0096	11.9952	0.00129
0.00045		24.0108	11.9946	0.00145
0.00050		24.0120	11.9940	0.00161

LARGEST BEARING SIZE

TOLERANCING FACTOR	BEARING LENGTH	BORE DIAMETER	BEARING RADIUS	EDGE GAP
'TF'	'L'	'LD'	'LR'	'EG'
0.00010	300	600.0600	299.9700	0.00804
0.00015		600.0900	299.9550	0.01206
0.00020		600.1200	299.9400	0.01608
0.00025		600.1500	299.9250	0.02009
0.00030		600.1800	299.9100	0.02411
0.00035		600.2100	299.8950	0.02813
0.00040		600.2400	299.8800	0.03215
0.00045		600.2700	299.8650	0.03617
0.00050		600.3000	299.8500	0.04019

NOTES: -ALL DIMENSIONS ARE IN MILLIMETERS

-FOR ANY GIVEN BEARING SIZE AND TOLERANCING FACTOR, THE EDGE GAP ('EG') DIMENSION WILL INCREASE AS THE BORE DIAMETER DECREASES. IN THE TABLE ABOVE THE NOMINAL BORE DIAMETER IS THE MINIMUM DIAMETER RECOMMENDED FOR USE WITH THE CHOSEN BEARING SIZE.

-BORE DIAMETERS 'WD' AND 'LD' ARE THE MAXIMUM SIZE ALLOWED FOR EACH GIVEN TOLERANCING FACTOR

-BEARING RADIUS 'WR' AND 'LR' ARE THE MINIMUM SIZE ALLOWED FOR EACH GIVEN TOLERANCING FACTOR

CONVEX RADIAL AIR BEARINGS

TOLERANCING FACTOR = 0.00035

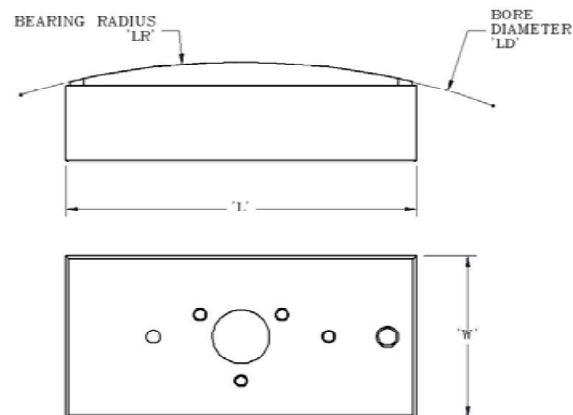
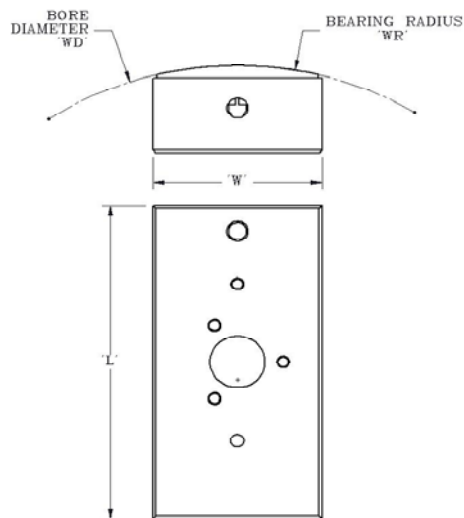

BEARING SIZE		MINIMUM RECOMMENDED SIZE		MAXIMUM RECOMMENDED SIZE	
'W'	'L'	BORE DIAMETER	BEARING RADIUS	BORE DIAMETER	BEARING RADIUS
		('WD' MIN.= 'W' X 2)	('WR' MIN.= 'W' X 1)	('WD' MAX.= 'W' X 10)	('WR' MAX.= 'W' X 5)
		'WD' MIN.	'WR' MIN.	'WD' MAX.	'WR' MAX.
12	24	24 +0.0084 -0.0000	12 +0.0000 -0.0042	120 +0.0420 -0.0000	60 +0.0000 -0.0210
15	30	30 +0.0105 -0.0000	15 +0.0000 -0.0053	150 +0.0525 -0.0000	75 +0.0000 -0.0263
20	40	40 +0.0140 -0.0000	20 +0.0000 -0.0070	200 +0.0700 -0.0000	100 +0.0000 -0.0350
25	50	50 +0.0175 -0.0000	25 +0.0000 -0.0088	250 +0.0875 -0.0000	125 +0.0000 -0.0438
40	80	80 +0.0280 -0.0000	40 +0.0000 -0.0140	400 +0.1400 -0.0000	200 +0.0000 -0.0700
50	100	100 +0.0350 -0.0000	50 +0.0000 -0.0175	500 +0.1750 -0.0000	250 +0.0000 -0.0875
75	150	150 +0.0525 -0.0000	75 +0.0000 -0.0263	750 +0.2625 -0.0000	375 +0.0000 -0.1313
100	200	200 +0.0700 -0.0000	100 +0.0000 -0.0350	1000 +0.3500 -0.0000	500 +0.0000 -0.1750
125	250	250 +0.0875 -0.0000	125 +0.0000 -0.0438	1250 +0.4375 -0.0000	625 +0.0000 -0.2188
150	300	300 +0.1050 -0.0000	150 +0.0000 -0.0525	1500 +0.5250 -0.0000	750 +0.0000 -0.2625

NOTES: -ALL DIMENSIONS ARE IN MILLIMETERS
-TOLERANCING FACTOR ('TF') 0.00035

BEARING SIZE		MINIMUM RECOMMENDED SIZE ('L' X 1)		MAXIMUM RECOMMENDED SIZE ('L' X 5)	
'W'	'L'	BORE DIAMETER	BEARING RADIUS	BORE DIAMETER	BEARING RADIUS
		('LD' MIN.= 'L' X 2)	('LR' MIN.= 'L' X 1)	('LD' MAX.= 'L' X 10)	('LR' MAX.= 'L' X 5)
		'LD' MIN.	'LR' MIN.	'LD' MAX.	'LR' MAX.
12	24	48 +0.0168 -0.0000	24 +0.0000 -0.0084	240 +0.0840 -0.0000	120 +0.0000 -0.0420
15	30	60 +0.0210 -0.0000	30 +0.0000 -0.0105	300 +0.1050 -0.0000	150 +0.0000 -0.0525
20	40	80 +0.0280 -0.0000	40 +0.0000 -0.0140	400 +0.1400 -0.0000	200 +0.0000 -0.0700
25	50	100 +0.0350 -0.0000	50 +0.0000 -0.0175	500 +0.1750 -0.0000	250 +0.0000 -0.0875
40	80	160 +0.0560 -0.0000	80 +0.0000 -0.0280	800 +0.2800 -0.0000	400 +0.0000 -0.1400
50	100	200 +0.0700 -0.0000	100 +0.0000 -0.0350	1000 +0.3500 -0.0000	500 +0.0000 -0.1750
75	150	300 +0.1050 -0.0000	150 +0.0000 -0.0525	1500 +0.5250 -0.0000	750 +0.0000 -0.2625
100	200	400 +0.1400 -0.0000	200 +0.0000 -0.0700	2000 +0.7000 -0.0000	1000 +0.0000 -0.3500
125	250	500 +0.1750 -0.0000	250 +0.0000 -0.0875	2500 +0.8750 -0.0000	1250 +0.0000 -0.4375
150	300	600 +0.2100 -0.0000	300 +0.0000 -0.1050	3000 +1.0500 -0.0000	1500 +0.0000 -0.5250

NOTES: -ALL DIMENSIONS ARE IN MILLIMETERS
-TOLERANCING FACTOR ('TF') 0.00035

50 McDonald Blvd., Aston, PA 19014 USA
www.newwayairbearings.com

NEWWAY[®]
air bearings

Phone: 610.494.6700 Fax: 610.494.0911
info@newwayairbearings.com

RADIAL AIR BEARINGS

USES AND APPLICATION ILLUSTRATIONS WITH DETAILED DESCRIPTIONS

Radial bearings have many potential applications. By ganging bearings together, any number of goals can be achieved through the use of New Way's radial concave and convex bearings. This paper seeks to show some of the iterations possible through illustration. However, there is probably no end to the types and number of application configurations possible.

Rings often have relatively large spinning diameters, resulting in large centrifugal forces and loads to bearing mounts on the ring, especially loads that are not evenly distributed around the circumference. These centrifugal forces can change the shape of the ring. Even balanced loads that are not uniform can change the shape of the ring. Care should be given in the design of the spinning artifact constraint system in anticipation of this.

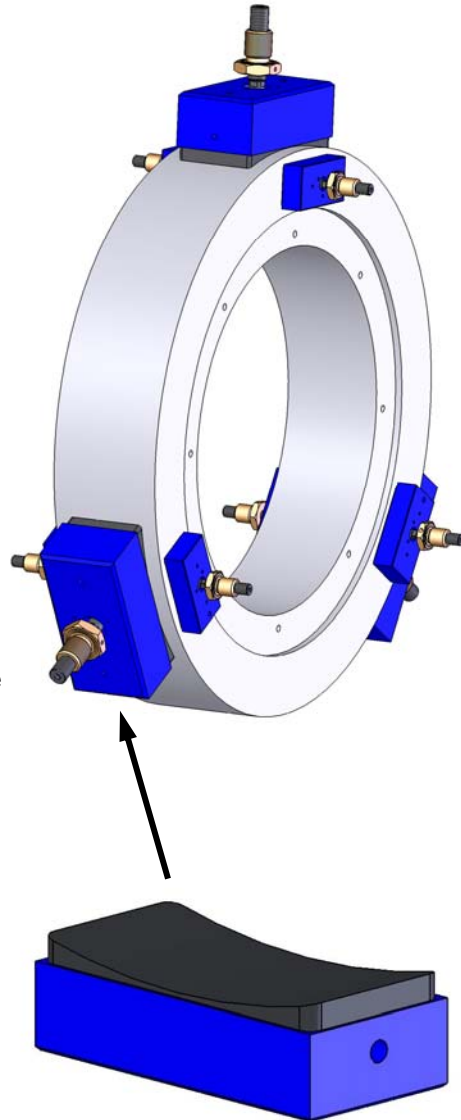

Concave bearings can be used when there is a desire to run on the Outer Diameter of a ring, or other artifact. The curve cut onto the bearing can be lengthwise (Shown) or across the width of the bearing. (Not shown)

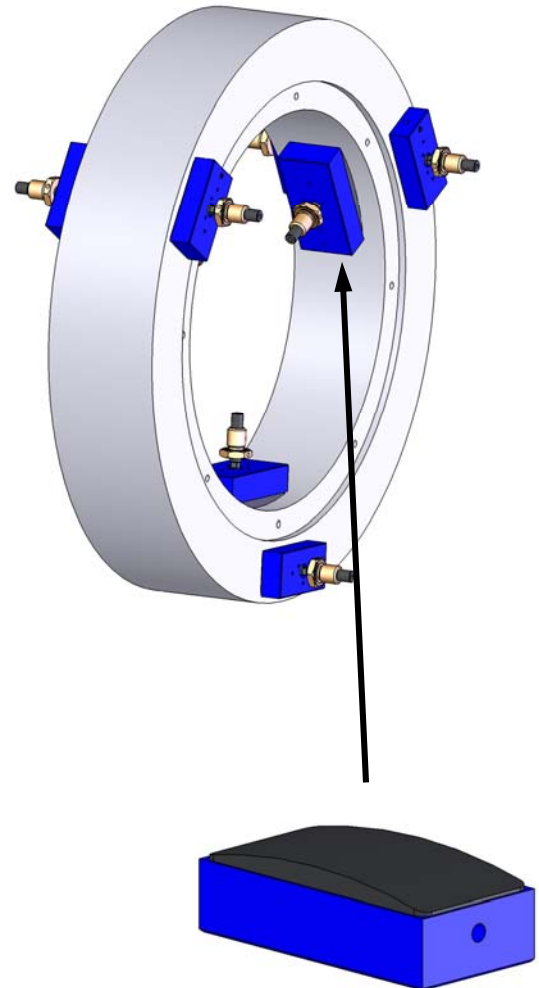

Convex bearings can be used when there is a desire to run on the Inner Diameter of a ring. (not shown in diagram)

RADIAL AIR BEARINGS

USES AND APPLICATION ILLUSTRATIONS WITH DETAILED DESCRIPTIONS

$$\text{BEARING LENGTH} \times \text{BEARING WIDTH} \times \text{NO. OF BEARINGS} \times \text{INPUT PRESSURE} \times .4 = \text{IDEAL LOAD}$$

For these reasons, care should be taken in calculating the load bearing capacity of the radial bearings.

The load is calculated based on the projected area of the bearing face.

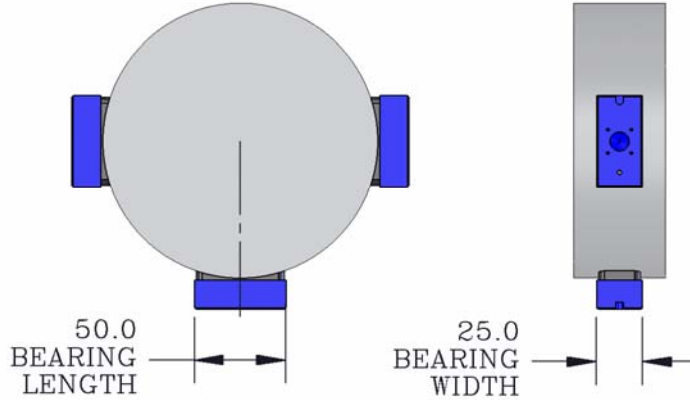

$$50\text{MM} \times 25\text{MM} \times 1 \times .41 \text{ MPA} \times .4 = 205 \text{ NEWTONS IDEAL LOAD}$$

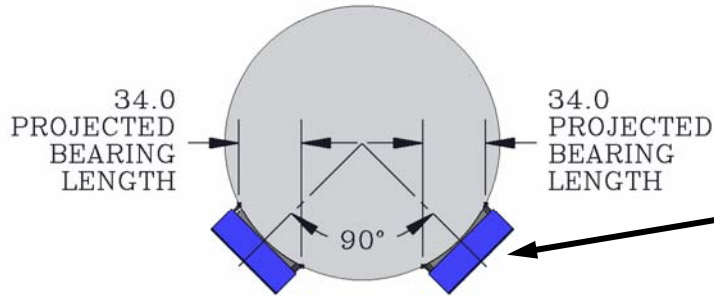

$$34\text{MM} \times 25\text{MM} \times 2 \times .41 \text{ MPA} \times .4 = 279 \text{ NEWTONS IDEAL LOAD}$$

These bearings have a higher load capacity than the bearings in the bottom illustration.

The load bearing capacity of the bearings will vary depending on the orientation to the load and the tolerances of the bearing and artifact. See page 27 for a note on Tolerances.

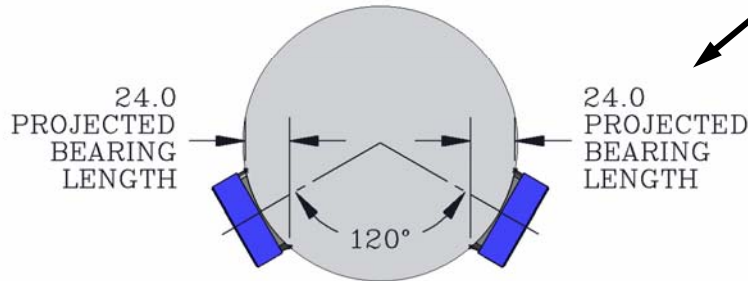

$$24\text{MM} \times 25\text{MM} \times 2 \times .41 \text{ MPA} \times .4 = 197 \text{ NEWTONS IDEAL LOAD}$$

NEWWAY[®]
air bearings

50 McDonald Blvd., Aston, PA 19014 USA
www.newwayairbearings.com

Phone: 610.494.6700 Fax: 610.494.0911
info@newwayairbearings.com

RADIAL AIR BEARINGS

USES AND APPLICATION ILLUSTRATIONS WITH DETAILED DESCRIPTIONS

BEARING LENGTH X BEARING WIDTH X NO. OF BEARINGS X INPUT PRESSURE X .4 = IDEAL LOAD

For these reasons, care should be taken in calculating the load bearing capacity of the radial bearings.

The load is calculated based on the projected area of the bearing face.

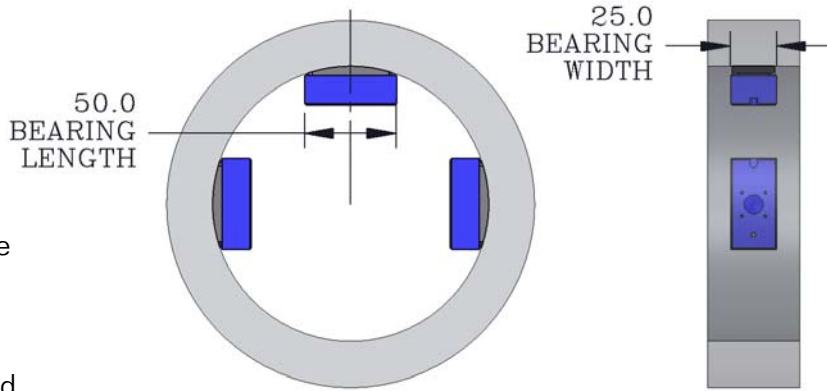

50MM X 25MM X 1 X .41 MPA X .4 = 205 NEWTONS IDEAL LOAD

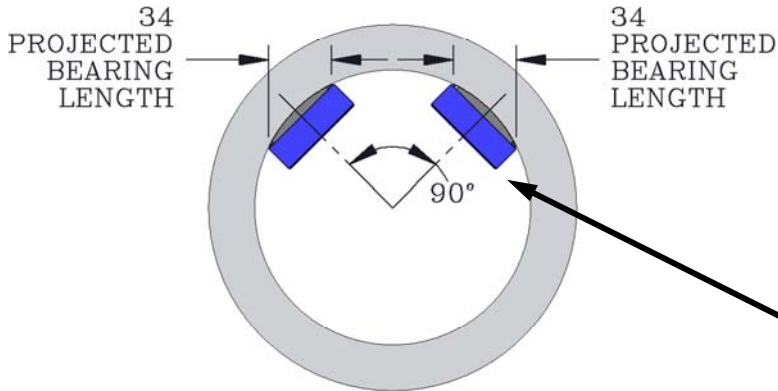

34MM X 25MM X 2 X .41 MPA X .4 = 279 NEWTONS IDEAL LOAD

These bearings have a higher load capacity than the bearings in the bottom illustration.

The load bearing capacity of the bearings will vary depending on the orientation to the load and the tolerances of the bearing and artifact. See page 27 for a note on Tolerances.

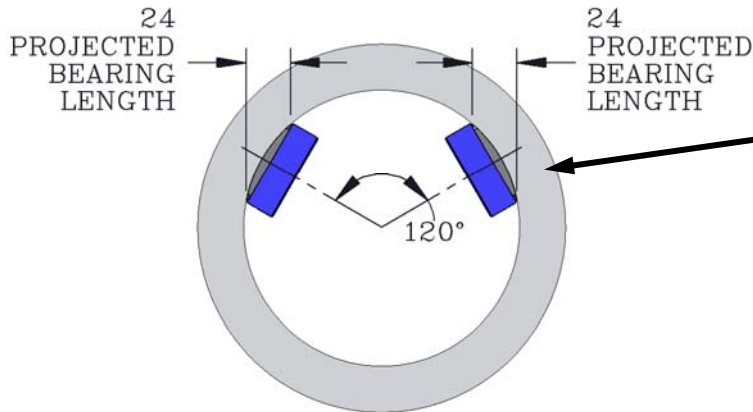

24MM X 25MM X 2 X .41 MPA X .4 = 197 NEWTONS IDEAL LOAD

NEWWAY[®]
air bearings

RADIAL AIR BEARINGS

USES AND APPLICATION ILLUSTRATIONS WITH DETAILED DESCRIPTIONS

By utilizing the concave detail *lengthwise* on the bearing, numerous applications and shaft options are available.

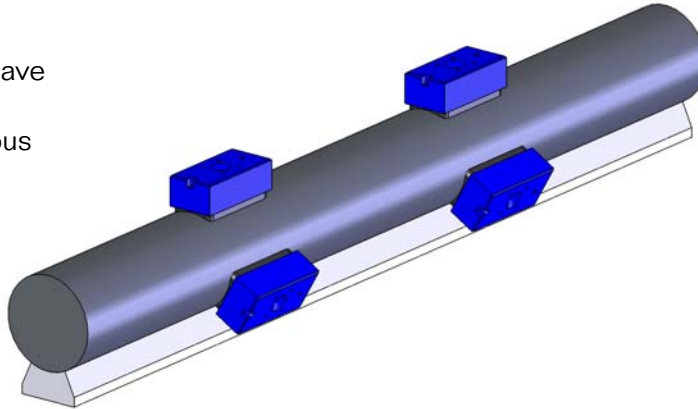

Here the shaft is able to slide axially, as well as rotate – all without friction. This is a demonstration unit that New Way has constructed to show the benefits of Radial Air Bearing technology. Please call New Way for more information and details.

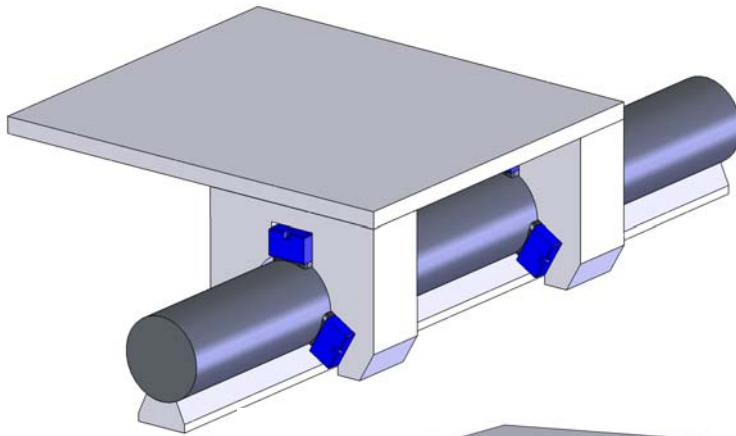
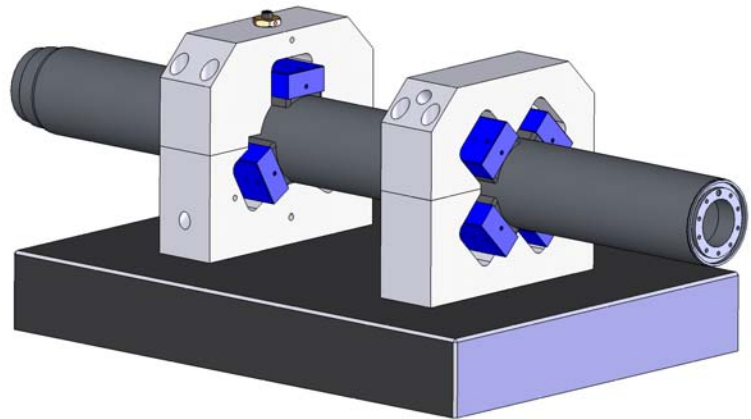

Through the use of commonly available $\frac{3}{4}$ shafting, simple and cost effect linear motion slides and ways can be fabricated.

The two views shown at left illustrate the use of an air bearing on the top of the shaft, which would deliver the greatest amount of load bearing capacity.

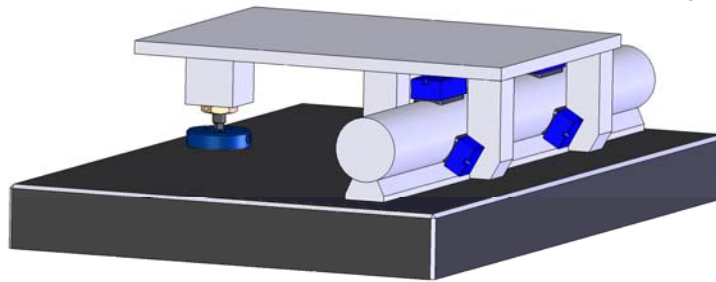

RADIAL AIR BEARINGS

USES AND APPLICATION ILLUSTRATIONS WITH DETAILED DESCRIPTIONS

By incorporating a magnet, a preload condition can be created on the *lengthwise* radial bearings.

This would be beneficial in applications involving the need for precise fly height of the table, relative to the shafting. Something to keep in mind; The magnet should be long enough to span any bolt holes that might be in the top of $\frac{3}{4}$ shafting.

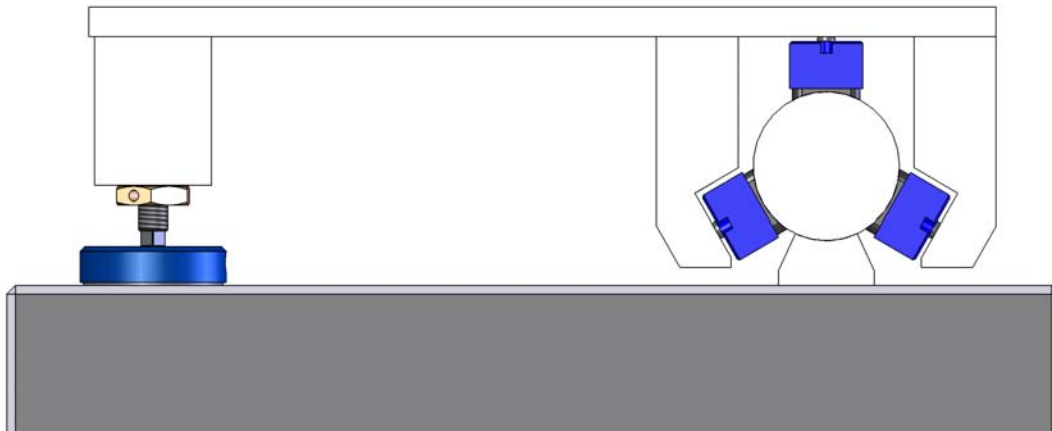
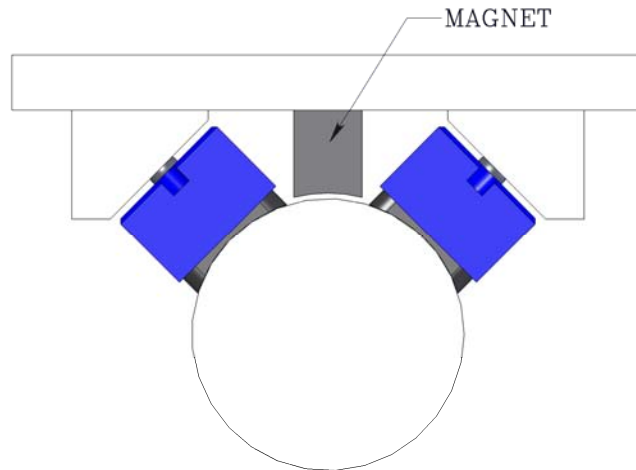

A further embodiment shows a bearing on the top of the rail, and a Puck type air bearing, which New Way pioneered – coupled together to create a kinematically designed linear way table. One would not want to use two rails in parallel, because the unit would be over constrained, where one rail would be fighting the other rail – since creating parallel artifacts in space is difficult.

Shown at left, the system illustrated does not need to be mounted on a granite block, merely a surface flat enough for the Puck type air bearing to ride upon, say $> 5\mu\text{m}$.

RADIAL AIR BEARINGS

USES AND APPLICATION ILLUSTRATIONS WITH DETAILED DESCRIPTIONS

By incorporating *Lengthwise* bearings on the shafting of drums, a non-contact zero friction drum assembly is possible. Using *Puck* type bearings at the ends of the shafts, constrains the drum axially.

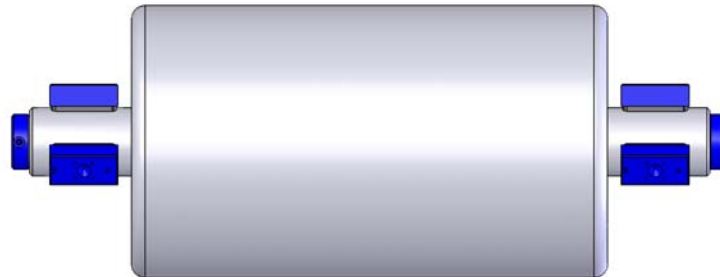

CENTERED ON END OF SHAFT

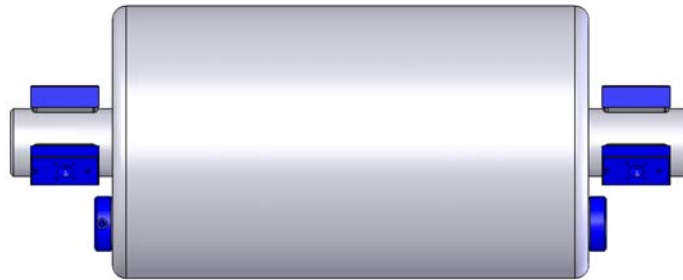

END FACE OF ROLL

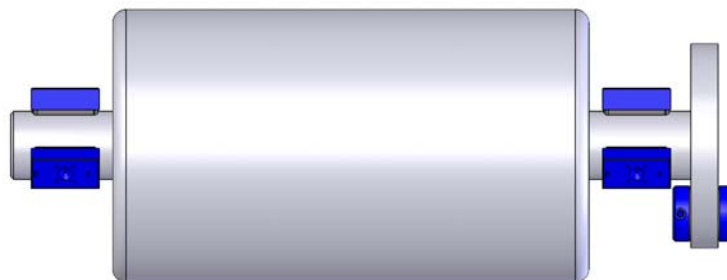

THRUST PLATE ON JOURNAL END

The above embodiments make possible the deflection of the drum and shafting, without affecting the orientation or relationship of the air bearings to the surface of the artifact. Since the bearings are mounted with ball type fixture mounts, they are able to articulate and self-align to the deflecting shaft. This could be of particular importance in critical applications.

RADIAL AIR BEARINGS

USES AND APPLICATION ILLUSTRATIONS WITH DETAILED DESCRIPTIONS

When spinning *discs* or shafts, a bearing on the top of the artifact can act as a pre-load, to the bottom load carrying bearings.

Care should be exercised when using *more than one* bearing as a pre-load, so as not to over constrain the assembly. By using a spring loading mechanism, or a pneumatic cylinder as a mounting support, this can be avoided.

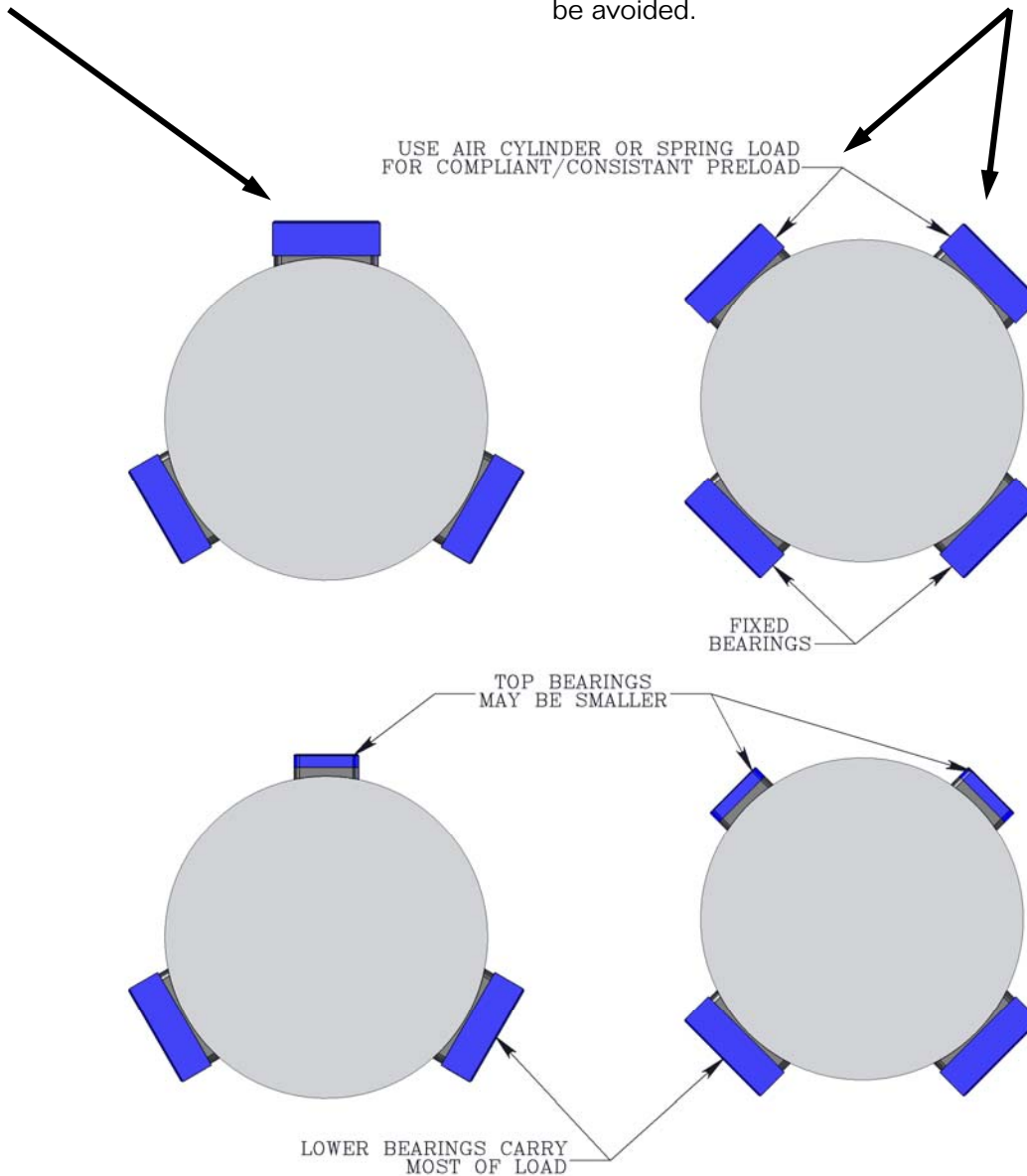

Often, the weight of the artifact can act as a proper amount of pre-load. This helps to save on the number of bearings, and increases the simplicity of the embodiment.

RADIAL AIR BEARINGS

USES AND APPLICATION ILLUSTRATIONS WITH DETAILED DESCRIPTIONS

Very large shafts or cylinders can be easily rotated through the use of air bearings.

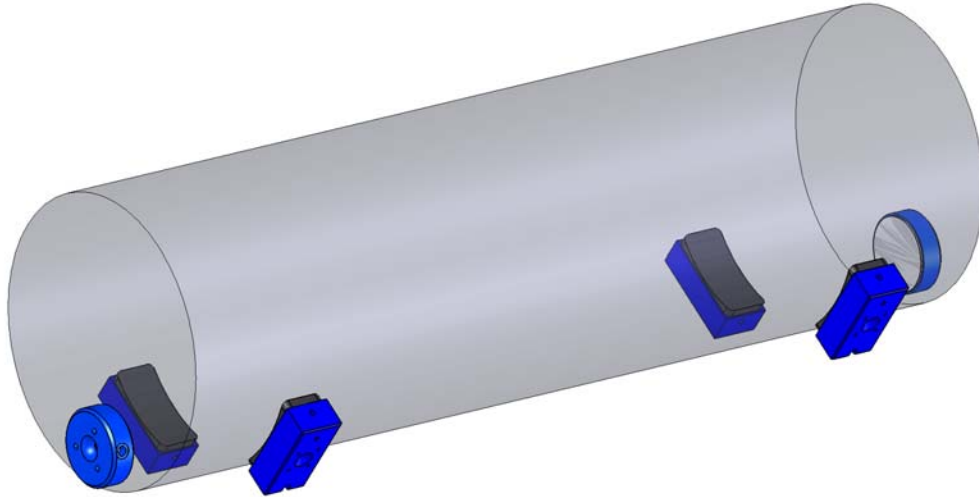

Very large drums or molds can be precisely rotated off of their ID or OD surfaces.

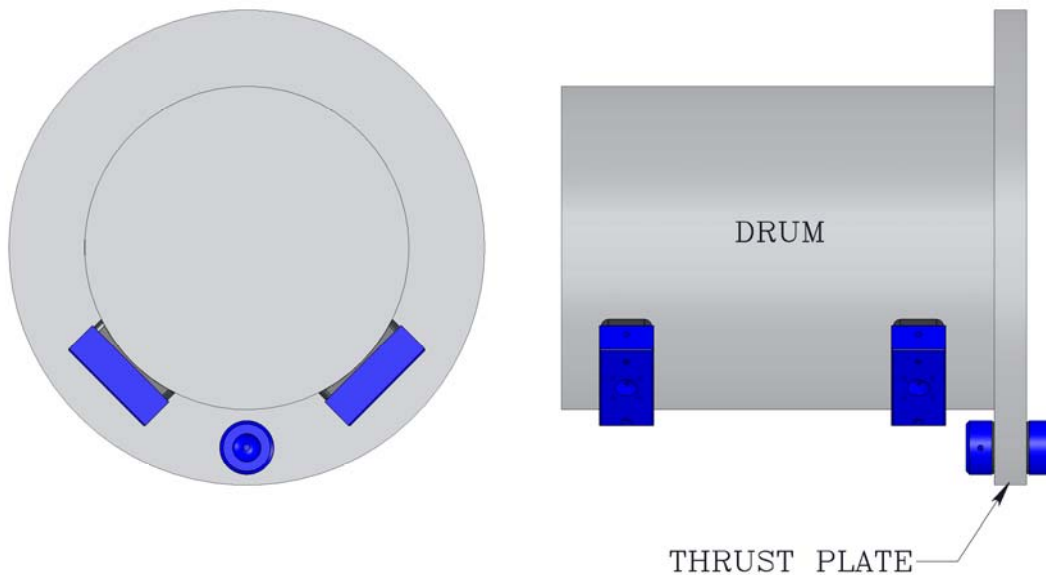

RADIAL AIR BEARINGS

USES AND APPLICATION ILLUSTRATIONS WITH DETAILED DESCRIPTIONS

When spinning *discs* a plane can be defined through the use of three bearings, in keeping with the exact constraint theory.

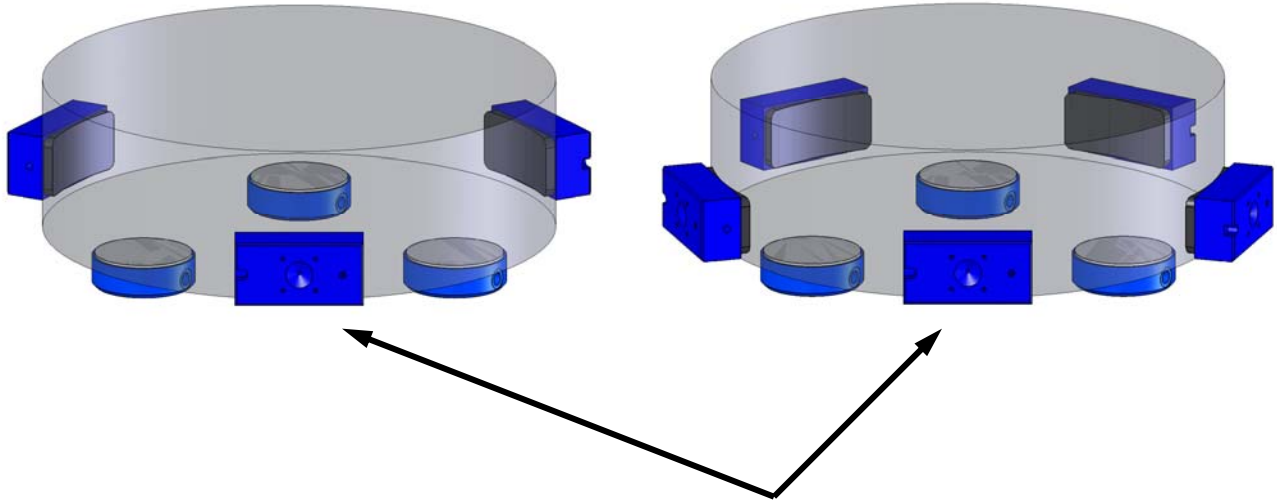

The use of five radial concave bearings on the outer diameter of these spinning discs is *more* accurate than the use of three bearings. The reason for this is that an odd number of bearings will improve the error motion of the disc – the more used average out any roundness defects in the artifact, for a more accurate rotation.

NOTE ON TOLERANCES

The tolerances on the bearings are relative to the tolerance on the shafting, or curved surface the bearing is being used on. The more the curved surface deviates from a round shape, the greater the gap that is formed between the curved bearing surface, and the surface of the artifact. When this gap enlarges, there is a greater opening for the air between the air bearing and the artifact to escape. When this happens, the bearing has a lower load bearing capacity, and will ride closer to the artifact. New Way has developed tolerance guidelines to account for this variation. By looking at the different bearing permutations, a suitable factor can be utilized, to insure that you are able to achieve the level of precision desired or necessary for the intended application.

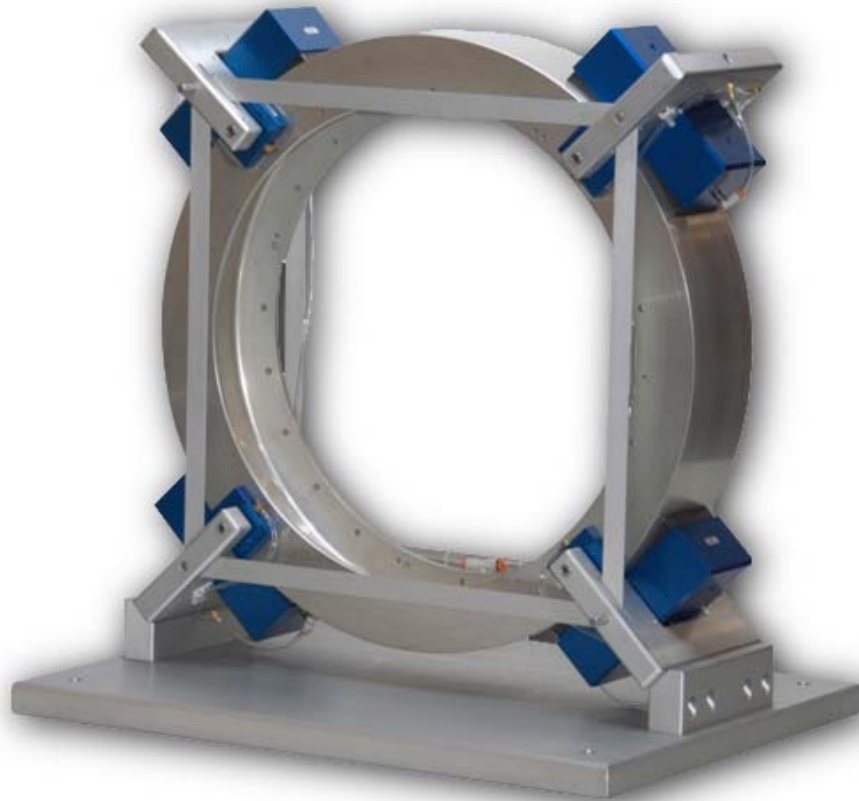

NEWWAY[®]
air bearings

50 McDonald Blvd., Aston, PA 19014 USA Phone: 610.494.6700 Fax: 610.494.0911
www.newwayairbearings.com info@newwayairbearings.com