

**2 YEAR**  
WARRANTY

MADE IN  
**USA**

CE

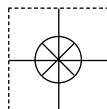

# User's Guide



*Shop online at*

**omega.com<sup>®</sup>**

Ω OMEGA<sup>®</sup>

*www.omega.com*

*e-mail: info@omega.com*

**ISO 9001**  
CERTIFIED  
CORPORATE QUALITY

STAMFORD, CT

**ISO 9002**  
CERTIFIED  
CORPORATE QUALITY

MANCHESTER, UK

*For latest product manuals:  
omegamanual.info*

# RD8800 Recorder



**OMEGAnet® Online Service**  
**www.omega.com**

**Internet e-mail**  
**info@omega.com**

### **Servicing North America:**

**USA:**  
ISO 9001 Certified

One Omega Drive, P.O. Box 4047  
Stamford CT 06907-0047  
TEL: (203) 359-1660 FAX: (203) 359-7700  
e-mail: info@omega.com

**Canada:**

976 Bergar  
Laval (Quebec) H7L 5A1, Canada  
TEL: (514) 856-6928 FAX: (514) 856-6886  
e-mail: info@omega.ca

### **For immediate technical or application assistance:**

**USA and Canada:** Sales Service: 1-800-826-6342 / 1-800-TC-OMEGA®  
Customer Service: 1-800-622-2378 / 1-800-622-BEST®  
Engineering Service: 1-800-872-9436 / 1-800-USA-WHEN®  
TELEX: 996404 EASYLINK: 62968934 CABLE: OMEGA

**Mexico:**

En Español: (001) 203-359-7803 e-mail: espanol@omega.com  
FAX: (001) 203-359-7807 info@omega.com.mx

### **Servicing Europe:**

**Benelux:**

Postbus 8034, 1180 LA Amstelveen, The Netherlands  
TEL: +31 (0)20 3472121 FAX: +31 (0)20 6434643  
Toll Free in Benelux: 0800 0993344  
e-mail: sales@omegaeng.nl

**Czech Republic:**

Frystatska 184, 733 01 Karviná, Czech Republic  
TEL: +420 (0)59 6311899 FAX: +420 (0)59 6311114  
Toll Free: 0800-1-66342 e-mail: info@omegashop.cz

**France:**

11, rue Jacques Cartier, 78280 Guyancourt, France  
TEL: +33 (0)1 61 37 2900 FAX: +33 (0)1 30 57 5427  
Toll Free in France: 0800 466 342  
e-mail: sales@omega.fr

**Germany/Austria:**

Daimlerstrasse 26, D-75392 Deckenpfronn, Germany  
TEL: +49 (0)7056 9398-0 FAX: +49 (0)7056 9398-29  
Toll Free in Germany: 0800 639 7678  
e-mail: info@omega.de

**United Kingdom:**

ISO 9002 Certified

One Omega Drive, River Bend Technology Centre  
Northbank, Irlam, Manchester  
M44 5BD United Kingdom  
TEL: +44 (0)161 777 6611 FAX: +44 (0)161 777 6622  
Toll Free in United Kingdom: 0800-488-488  
e-mail: sales@omega.co.uk

---

It is the policy of OMEGA to comply with all worldwide safety and EMC/EMI regulations that apply. OMEGA is constantly pursuing certification of its products to the European New Approach Directives. OMEGA will add the CE mark to every appropriate device upon certification.

The information contained in this document is believed to be correct, but OMEGA Engineering, Inc. accepts no liability for any errors it contains, and reserves the right to alter specifications without notice.

**WARNING:** These products are not designed for use in, and should not be used for, human applications.

# RD8800 Manual

## Overview

Chapter 1 .....	General Information
Chapter 2 .....	Installation and Wiring
Chapter 3 .....	Getting Started
Chapter 4 .....	Operation
Chapter 5 .....	Programming
Chapter 6 .....	Calibration
Chapter 7 .....	Get Data Software
Appendix A .....	Configuring a 1-5 Vdc input for a 0-250 psig pressure transducer
Appendix B .....	Configuring a 4-20 mA input to equal 0 to 150 gpm
Appendix C .....	Configuring a J type T/C input for a 100-750° C range
Appendix D .....	Configuring the Totalizer
Appendix E .....	Setting the Jumpers for the 3 or 6 Channel Mechanical or Solid State Relay
Warranty/Disclaimer and Return Requests/Inquires	

## SAFETY NOTICE

This Safety Notice has been included to emphasize the **DANGER OF HAZARDOUS VOLTAGES** on the **REAR TERMINAL PANEL** of your instrument. **USE EXTREME CAUTION WHEN INSTALLING OR SERVICING** your instrument. Please read the entire contents of the Installation and Wiring Chapter of this manual before attempting to install or service your instrument.

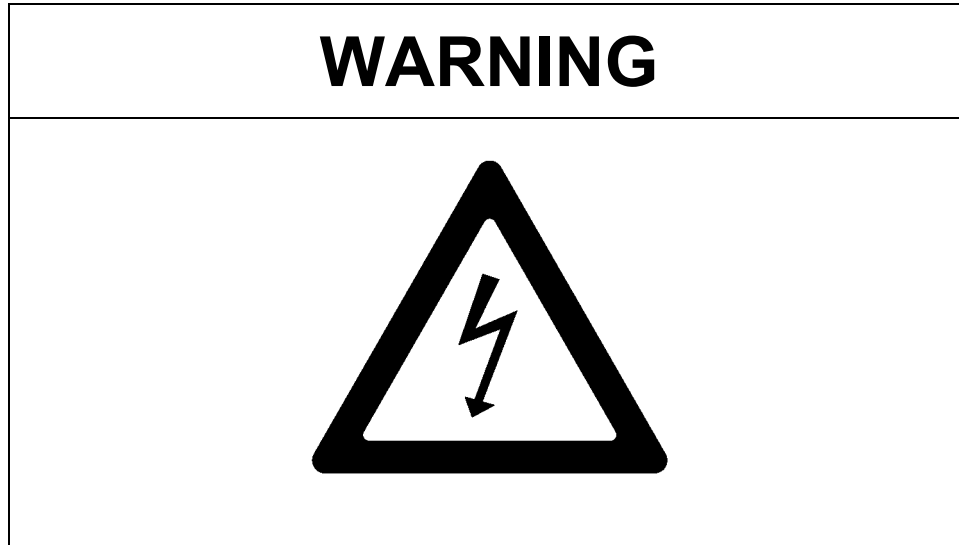

**Use Extreme caution when servicing the rear terminal of your instrument.**

## WEEE NOTICE



**In order to comply with EU Directive 2002/96/EC on Waste Electrical and Electronic Equipment (WEEE):**

This product may contain material which could be hazardous to human health and the environment. DO NOT DISPOSE of this product as unsorted municipal waste. This product needs to be RECYCLED in accordance with local regulations, contact your local authorities for more information. This product may be returnable to your distributor for recycling - contact the distributor for details.

**Para obedecer con EU Directiva 2002/96/EC en el Desecho el Equipo Eléctrico y Electrónico (WEEE):**

Este producto puede contener la materia que podría ser la salud humana perjudicial para y el ambiente. NO se DESHAGA de este producto el desecho municipal como no clasificado. Estas necesidades del producto para SER RECICLADAS de acuerdo con las regulaciones locales, contactan su administración local para más información. Este producto puede ser retornable a su distribuidor para reciclar - contacta el distribuidor para detalles.

**Afin de respecter la directive européenne 2002/96/EC sur l'Équipement Electronique et les Déchets Electriques :**

Ce produit pourrait contenir des matières qui peuvent être dangereuses pour la santé de l'homme et de l'environnement. Ne pas jeter ce produit dans un container municipal inapproprié. Ce produit doit être recyclé en accord avec les arrêtés locaux; contacter les autorités locales pour plus de renseignements. Ce produit peut être renvoyé au distributeur pour recyclage - Contacter votre distributeur pour plus de details.

**Um den Vorschriften der EU-Direktive 2002/96/EC bezüglich elektrischer und elektronischer Abfallstoffe (WEEE) nachzukommen:**

Dieses Produkt kann Materialien enthalten, welche gesundheitsgefahrend und umweltschädlich sind. Dieses Produkt DARF NICHT wie unsortierter Hausmuell entsorgt werden. Dieses Produkt muss gemaess den oertlichen Bestimmungen recycled werden, bitte kontaktieren Sie die lokalen Behoerden fuer weitere Informationen. Sie koennen dieses Produkt zum Recycling an Ihren Haendler zurueckgeben, bitte kontaktieren Sie den Haendler fuer weitere Details.

# Chapter 1 General Description

- Introduction ..... 1-1
  
- 1.1 Recorder Description ..... 1-2
  - 1.1.1 Inputs ..... 1-2
  - 1.1.2 Instrument Size ..... 1-2
  - 1.1.3 Menus ..... 1-2
    - 1.1.3.1 Display Menu ..... 1-3
    - 1.1.3.2 Program Menu ..... 1-3
    - 1.1.3.3 Function Menu ..... 1-3
    - 1.1.3.4 Hidden Menu ..... 1-3
  - 1.1.4 Memory ..... 1-3
  - 1.1.5 Clock ..... 1-3
  - 1.1.6 Recorder Construction ..... 1-3
  
- 1.2 Recording Options ..... 1-4
  - 1.2.1 Floppy Disk Drive ..... 1-4
  - 1.2.2 CompactFlash™ Drive ..... 1-4
  
- 1.3 Recorder Options ..... 1-4
  - 1.3.1 Digital Input and Output ..... 1-4
  - 1.3.2 Communications Interface ..... 1-4
  
- 1.4 Specifications ..... 1-5

# CHAPTER 1

---

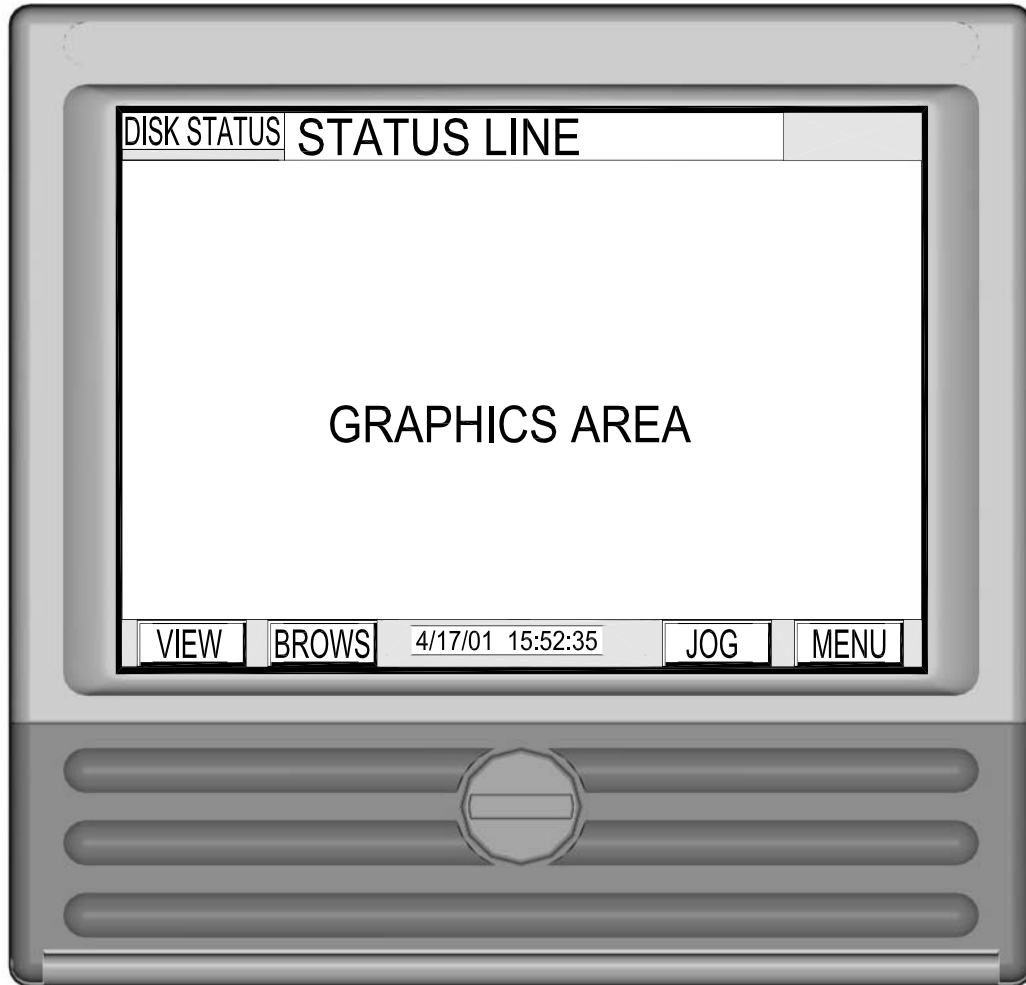

Figure 1-1 Solid State Data Recorder

This manual is a user reference guide for the Solid State Paperless Data Recorder (Figure 1-1). The manual provides detailed instruction for installation, operation, programming, calibration and maintenance of the instrument.

The recorder is a sophisticated piece of equipment that requires some level of programming before use. The user is advised to read this manual in its entirety before proceeding with the installation and programming. Refer to Chapter 3, Getting Started for minimum configuration. Step by step instructions for a few sample applications are included in Appedixes A-D.

## 1.1 Recorder Description

The Solid State Data Recorder is a Paperless Recording instrument. Data is stored on either an internal floppy disk or a CompactFlash™ card.

All data is stored in MSDOS format and may be archived or analyzed on any IBM compatible PC running Microsoft Windows 3.1, Windows 95/98 or Windows NT/2000/XP using the available *Companion Software*. The instrument retains all the features of a traditional Paper Chart Recorder by virtue of its large STN monochrome or TFT color Liquid Crystal Display (LCD) which presents the data in the traditional chart mode as well as in bar graph or digital numeric form.

The unit has many features and functions which are unique and cannot be performed on traditional paper recorders, such as data compression and historic data browsing. The recorder is programmed via a touch screen keypad on the display.

The Recorder will measure and process up to twelve direct inputs, calculated, conditional, or external points for logging, trending, or data manipulation.

If direct inputs are not desired, the Data Recorder will accept up to fifteen points from a combination of calculated, conditional, or external point types.

### 1.1.1 Inputs

Direct input sources may come from voltage, current, dry contacts, thermocouple, or RTD sources. The voltage and current ranges accepted by the instrument include:  $\pm 150$  mV,  $\pm 1.25$  V,  $\pm 2.5$  V,  $\pm 12.5$  V, and  $\pm 25$  V; 4 to 20 mA, 0 to 20 mA and 10 to 50 mA current. Thermocouple inputs include Type J,K,T,E,R,S,B,C, N (Nicro), L and Ninimo. RTD inputs accepted include 10 ohm Cu, 100 ohm Platinum, 200 ohm Platinum, 120 ohm Nickel, 100 ohm Nickel and 1000 ohm Nickel.

### 1.1.2 Instrument Size

The instrument is sized to fit in a DIN standard panel cutout of 5.43 inches x 5.43 inches [138 mm x 138 mm] and requires 7.41 inches [188.2 mm] behind panel depth, not including power and input source cable space needed. Actual dimensions of the instrument are shown in Figure 2-1 Recorder Dimensions in Chapter 2 of this manual.

### 1.1.3 Menus

The instrument's features are accessed through a series of menus. Press the **MENU** button displayed in the bottom right hand corner of the LCD screen. The STATUS bar along the top of the screen displays the various Recorder parameters. (Refer to Section 3.1). The Command Button Bar contains three user programming option buttons - **DISPL**ay, **PROG**ram, and **FUNC**tion (see Figure 1-2 below). Each menu level features easy-to-follow prompts that simplify operation.



Figure 1-2 The Command Button Bar

### **1.1.3.1 Display Menu**

The Display Menu is accessed by pressing the Display button (**DISPL**) on the Command Button Bar. This menu allows you to display any programmed point or series of points, or any current alarm or series of alarms on the Status Line along the top of the display. The version of operating software can also be shown in a pop up window.

### **1.1.3.2 Program Menu**

The Program Menu is accessed by pressing the Program button (**PROG**) on the Command Button Bar. This Menu item may be passcode protected. The Program Menu allows you to define the system operating parameters. Menu driven prompts, answered by yes, no or by entering the desired value, enable you to customize the instrument to meet your application requirements. Refer to Chapter 5 for detailed instructions on programming.

### **1.1.3.3 Function Menu**

The Function Menu is accessed by pressing the Function button (**FUNC**) on the Command Button Bar. This Menu item may be passcode protected. The Function Menu allows you to Activate, Bypass, and/or Reset a point. This menu also allows you to change between High and Low Display Chart Speed or Record Speed, turn Alarm Check On or Off, and choose Scale Set 1 or 2.

### **1.1.3.4 Hidden Menu**

The Hidden Menu can only be accessed by pressing a certain combination of buttons and may be passcode protected (in conjunction with the Program Menu). This Menu allows you to Initialize the Recorder, set Passcodes, perform Calibrations and perform Diagnostics on the Recorder. Refer to Chapter 4 for detailed information.

## **1.1.4 Memory**

All the Random Access Memory (RAM) in the Recorder is battery backed. This enables the unit to recover in the event of a mains failure with minor data loss. Any programming will be protected in the event of power removal and past browse data is maintained in the off state. The battery is a Non-rechargeable lithium and will keep memory intact for at least 12 months.

## **1.1.5 Clock**

A real time clock monitors the time and date in the event of a power loss. It uses the same battery as the Random Access Memory.

## **1.1.6 Recorder Construction**

The Data Recorder features modular construction. Power Supply and Analog conditioning modules are conveniently accessible for fast and simple troubleshooting and/or removal. The floppy disk or CompactFlash™ drive can be accessed through the front of the unit.



## 1.2 Recording Options

The Recorder can be ordered with one of two storage mediums: a standard PC compatible Floppy disk drive or a CompactFlash™ drive. The optional *Companion Software* supports both media types.

### 1.2.1 Floppy Disk Drive

The Floppy disk drive uses PC compatible 3½ inch (89mm) floppy disks. These disks store 1.44 Megabytes of data which translates to approximately 700,000 data samples (each sample is 16 bits). The disks are magnetic media and the drives are mechanical. This limits their use in harsh environments where vibration or temperature is a problem, but they are convenient as they are very inexpensive and can simply be plugged into any IBM compatible PC.

**IMPORTANT:** Please format all floppy disks in the Recorder prior to use. Because floppy disks are volatile, do not use disks for more than 2-3 months. Also, use a floppy cleaning disk every 4 months to clean the heads.

### 1.2.2 CompactFlash™ Drive

The CompactFlash™ card is a small solid state memory card containing Flash memory. The Recorder supports memory cards up to 512 Megabytes. The cards require an adapter for use with your PC. Typical adapters use the USB port and are inexpensive. The use of Sandisk Industrial CompactFlash™ cards is recommended and is fully supported.

## 1.3 Recorder Options

Additional functions and capabilities can be added to the Recorder and are described in the following sections.

### 1.3.1 Digital Input and Output

This option provides three or six mechanical form C (Normally Open, Common, Normally Closed contacts) relay outputs capable of switching 250 Vac as well as three isolated digital control inputs, or three or six solid state open collector type contacts able to switch 30 Vdc at 0.5 Amps. The relay outputs can be programmed to respond to alarm events while the digital inputs can be used to trigger events such as changing recording speeds or stopping and starting recording.

### 1.3.2 Communications Interface

There are two communications options available:

1. An isolated RS232/RS485 interface using the Modbus protocol with the Recorder acting as a slave device in a Modbus RTU or Modbus ASCII environment.
2. An 802.3 compatible Ethernet option with RJ45 four wire connection.

## 1.4 Specifications

### OPERATING

**Input Signals:** DC Voltage: Linear, Industrial Square Root, Logarithmic  
 Full Scale Ranges:  $\pm 150$  mV,  $\pm 1.25$  V,  $\pm 2.5$  V **Accuracy**  $\pm 0.06\%$   
 $\pm 12.5$  V and  $\pm 25$  V **Accuracy**  $\pm 0.1\%$   
 DC Current: 4 to 20 mA, 0 to 20 mA and 10 to 50 mA  
**Accuracy**  $\pm 0.15\%$  using external 50 ohm 0.1% shunt

**Thermocouple:** Resolution 0.1 °C

Type	Range (°C)	Accuracy (°C)	Range (°F)	Accuracy (°F)
J	-210 to -100 °C	$\pm 2.5$ °C	-340 to -150 °F	$\pm 5$ °F
	-100 to 1200 °C	$\pm 1.5$ °C	-150 to 2190 °F	$\pm 3$ °F
K	-270 to -100 °C	$\pm 2.5$ °C	-450 to -150 °F	$\pm 5$ °F
	-100 to 1372 °C	$\pm 1.5$ °C	-150 to 2500 °F	$\pm 3$ °F
T	-270 to -100 °C	$\pm 2.5$ °C	-450 to -150 °F	$\pm 5$ °F
	-100 to 400 °C	$\pm 1.5$ °C	-150 to 750 °F	$\pm 3$ °F
E	-270 to -100 °C	$\pm 2.5$ °C	-450 to -150 °F	$\pm 5$ °F
	-100 to 1000 °C	$\pm 1.5$ °C	-150 to 1832 °F	$\pm 3$ °F
R	-50 to 1768 °C	$\pm 3$ °C	-58 to 3200 °F	$\pm 6$ °F
S	-50 to 1768 °C	$\pm 3$ °C	-58 to 3200 °F	$\pm 6$ °F
B	0 to 1820 °C	$\pm 4$ °C	32 to 3300 °F	$\pm 7$ °F
C	0 to 2400 °C	$\pm 3$ °C	32 to 4350 °F	$\pm 6$ °F
N	-270 to -100 °C	$\pm 2.5$ °C	-450 to -150 °F	$\pm 5$ °F
	-100 to 1300 °C	$\pm 1.5$ °C	-150 to 2372 °F	$\pm 3$ °F

Reference junction compensation accuracy  $\pm 0.5$ °C (0 °C to 50 °C)  
 Thermocouple burnout detection - internal

**RTD:** Base accuracy 0.2% or 0.5 °C (1 °F). Resolution 0.1 °C.  
 2, 3 or 4 wire connection. Cable compensation to +50 Ohm  
 Open and short circuit detection.

10ohm Cu	-70 to 170 °C	-94 to 338 °F
100 ohm Pt 385	-220 to 850 °C	-364 to 1560 °F
100 ohm Pt 392	-180 to 820 °C	-292 to 1500 °F
200 ohm Pt 385	-220 to 400 °C	-364 to 750 °F
200 ohm Pt 392	-180 to 400 °C	-292 to 750 °F
120 ohm Ni	-70 to 300 °C	-94 to 570 °F
1000 ohm Ni	-60 to 209 °C	-76 to 408 °F

**Input Resolution** 0.0015% of full scale, 16 bit unless otherwise stated  
**Input Impedance** >10 megohms on 150 mV, 1.25 V and 2.5 V Ranges, >100 K on 12.5 V, and 25 ranges  
**Input Channels** 2, 4, 6 or 12 direct  
**Maximum Input Isolation** 50 Vdc  
 250 Vdc or peak AC channel to channel, 300 Vdc or peak AC to Chassis  
**Measurement Rate** 8 times per second on all direct input channels  
**Common Mode Noise Rejection** >100 dB, 50/60 Hz  
**Normal Mode Noise Rejection** >50 dB at 50/60 Hz  
**Math Functions** +, -, x, /, logarithms, totalization, powers, averages, and timers

### RECORDING

**Recording Rates** User programmable from 8 samples per second to 1 sample every 600 seconds (10Minutes).  
 Channels independently programmed.

**Data Format** Proprietary binary format. User File naming.

**Data Storage Capacity** Data stored in non-volatile RAM and recorded automatically to on board removable media

**Removable Media Types** 3 ½ inch (89mm) Floppy disk - approximately 700,000 samples for a 1.44 Megabyte Disk  
 CompactFlash™ cards - approximately 256,000,000 samples for 512 Megabyte Card

**Internal Media** One Megabyte RAM (Non-Volatile)  
 Two Megabyte RAM (Non-Volatile) - optional

**File types** Data Files, Alarm and Event files, Configuration files, Language Files, Multiple files of different names on a single disk.

## Chapter 1 General Description

### DISPLAY

<b>Display Type Mono</b>	CCFL backlit STN Liquid Crystal Display (5.0 inch) with touchscreen control
<b>Resolution Mono</b>	240 (H) X 128 (V) pixels
<b>Display Type Color</b>	CCFL backlit Active Matrix TFT Liquid Crystal Display (5.6 inch) with touchscreen control
<b>Resolution Color</b>	320 (H) X 240 (V) pixels
<b>Display Modes</b>	Graphics (Trending vertical or horizontal), Bar Graphs (vertical or Horizontal), Digital Meter, Alphanumeric Alarm and Event data or combinations on a split screen. Review trended data.
<b>Virtual Chart Speed</b>	Programmable: 0.5 in/hr to 600 in/hr (10 mm/hr to 15,000 mm/hr)
<b>Virtual Chart Scales</b>	2 sets of 8 scales
<b>Display Windows</b>	Time/Date, Graphics (Bars, Large Digital, Trends), Disk Status, System Status, Menu Button Bar, Unit Identification, Alarms/Events.

### OTHER



<b>Power Requirements</b>	100 to 240 Vac, 50/60 Hz. 35 VA max. Optional 24 Vdc $\pm$ 15%
<b>Power Fail Protection</b>	Programmed parameters stored in non-volatile memory. Clock battery backed. Data retention time without power > 12 months.
<b>Operating Range</b>	-10 °C to 50 °C (5 °C to 40 °C for floppy media), Maximum relative humidity 80% for temperatures up to 31 °C decreasing linearly to 50% relative humidity at 40 °C.
<b>Safety</b>	Meets the requirements of UL-3111-1 and EN61010-1:2001 when installed in accordance with the instructions in this manual.
<b>EMC</b>	Meets the requirements of EN61326:1998 and CE directive 89/336/EEC when installed in accordance with the instructions in this manual.
<b>Input Voltage</b>	100 to 240 Vac, 50/60 Hz or 125 Vdc @ 35VA max.
<b>Weight</b>	Approx. 7 lbs (3.2 kg) - weight will vary depending on options installed

## SAFETY NOTICE

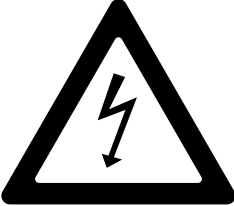
This Safety Notice has been included to emphasize the danger of hazardous voltages on the **REAR TERMINAL PANEL** of your instrument. **USE EXTREME CAUTION WHEN INSTALLING OR SERVICING** your instrument. Please read the entire contents of the Installation and Wiring Chapter before attempting to install or service your instrument.

<p style="text-align: center;"><b>WARNING</b></p> 	<p>ELECTRIC SHOCK HAZARD MAY CAUSE INJURY OR DEATH. USE EXTREME CAUTION WHEN INSTALLING OR SERVICING REAR TERMINAL PANEL. FOLLOW INSTRUCTIONS BELOW.</p>
---	--

### POWER INPUTS WARNING

When connecting power to the Rear Terminal Panel of your instrument, it is important to ensure that the AC mains cable has an effective ground and provide a low impedance earth ground connection (Safety Ground) to the screw terminal on the rear panel labeled “” or “GND” to prevent the possibility of electrical shock. Power may be exposed on the Rear Terminal Panel and is exposed inside the instrument case. When wiring, use the supplied AC mains cable or recommended plug, make sure the HOT wire, or Line 1 is connected to L/H. Make sure the NEUTRAL wire, or Line 2, is connected to N, and make sure a low impedance SAFETY GROUND wire is connected to “” or “GND”.

### SIGNAL INPUTS WARNING

Use extreme caution when wiring signal input connections. Hazardous potentials may exist on signal input terminals, which are floating, with respect to instrument ground. These hazardous potentials may be exposed inside the instrument case and on the Rear Terminal Panel of your instrument. Any voltage potential at the signal source will exist on the instrument’s respective signal input terminal: e.g. power generator stator winding temperature-monitoring thermocouples.

### CONTACT OUTPUT TERMINALS WARNING

Use extreme caution when wiring contact output connections. Hazardous potentials may exist on contact output terminals, which are floating, with respect to instrument ground. These hazardous potentials may be exposed inside the instrument case and on the Rear Terminal Panel of your instrument. Any voltage potentials at the contact circuit will exist on the instrument’s respective contact output terminals: e.g. line-powered circuits.

# Chapter 2 Installation/Wiring

2.1 Equipment Handling .....	2-1
2.1.1 Initial Inspection .....	2-1
2.1.2 Unpacking Procedure .....	2-1
2.1.3 Detected Damage .....	2-1
2.1.4 Equipment Return .....	2-1
2.1.5 Storage .....	2-1
2.2 Installation .....	2-2
2.2.1 Panel Mounting .....	2-3
2.3 Wiring Specifications and Procedures .....	2-5
2.3.1 Power Requirements .....	2-5
2.3.2 Power Connections .....	2-5
2.3.3 Signal Input Wiring .....	2-6
2.3.3.1 Thermocouple Inputs .....	2-7
2.3.3.2 Resistance Temperature Detector (RTD) Inputs .....	2-7
2.3.3.3 Linear Inputs .....	2-7
2.3.4 Relay Output, Contact Input .....	2-8
2.3.4.1 Mechanical Relay Option .....	2-8
2.3.4.2 Solid State Relay Option .....	2-8
2.3.4.3 Opto-isolated Inputs/Outputs .....	2-8
2.4 Serial Interface Option .....	2-9
2.5 Ethernet Option .....	2-10
2.6 Cleaning .....	2-10
2.7 Contrast Adjust (Monochrome Only) .....	2-10

## CHAPTER 2

---

This chapter provides information and procedures on installing and wiring the Recorder. Included are handling procedures, installation and wiring specifications, and instructions for both standard and optional equipment.

### 2.1 Equipment Handling

#### 2.1.1 Initial Inspection

Exercise care when unpacking the instrument from the shipping carton. The instrument is packed in a shock-proof foam retainer to prevent damage during normal transit. If damage to the shipping carton is evident, ask the carrier's representative to be present when the instrument is unpacked.

#### 2.1.2 Unpacking Procedure

To unpack your Recorder, first remove the foam retainer and instrument from the shipping carton. Then, carefully remove the instrument from the foam retainer.

#### 2.1.3 Detected Damage

If damage is detected after unpacking the instrument, re-pack the instrument and return it to the factory as described in the following section.

#### 2.1.4 Equipment Return

Before returning a damaged or malfunctioning instrument to the factory for repairs, contact Customer Service at Omega Engineering. A Return Merchandise Authorization number must be obtained from the factory before returning an instrument for any reason.

#### 2.1.5 Storage

For prolonged storage before installation, re-pack the Recorder in the shipping container. Cushion the Recorder with foam molding or an equivalent and store in a cool, dry area. We do not recommend storage of the Recorder for more than one year. If longer storage time is required, contact the factory for additional storage information.

## 2.2 Installation

The instrument is intended to operate in the following environment:

<b>Indoor Use Only</b>	
<b>Installation Category II</b>	per IEC 664
<b>Pollution Degree Level II</b>	per UL3111-1 / IEC61010-1
<b>Altitude</b>	up to 2,000 m
<b>Temperature</b>	-10 °C to 50 °C (5 °C to 40 °C for floppy media) operating per UL3111-1 / IEC61010-1
<b>Humidity</b>	Maximum relative humidity 80% for temperatures up to 31 °C decreasing linearly to 50% relative humidity at 40 °C
<b>AC Mains Supply</b>	100 - 240 Vac ~ 50/60 Hz 35 Vac ±10%

**NOTE:** The recorder is designed to be panel mounted and as such should be considered as permanently connected. Disconnection from the supply must be possible via a customer supplied switch or circuit breaker. This disconnection device must be included in the panel installation and should be clearly marked, in close proximity to the Recorder and easily accessible to the operator.

The Recorder is sized to fit in a standard DIN panel cutout of 5.43" x 5.43" [138 mm x 138 mm] and requires 7.41" [188.2 mm] behind panel depth not including power and input source cable space needed. Actual dimensions are shown in Figure 2-1.

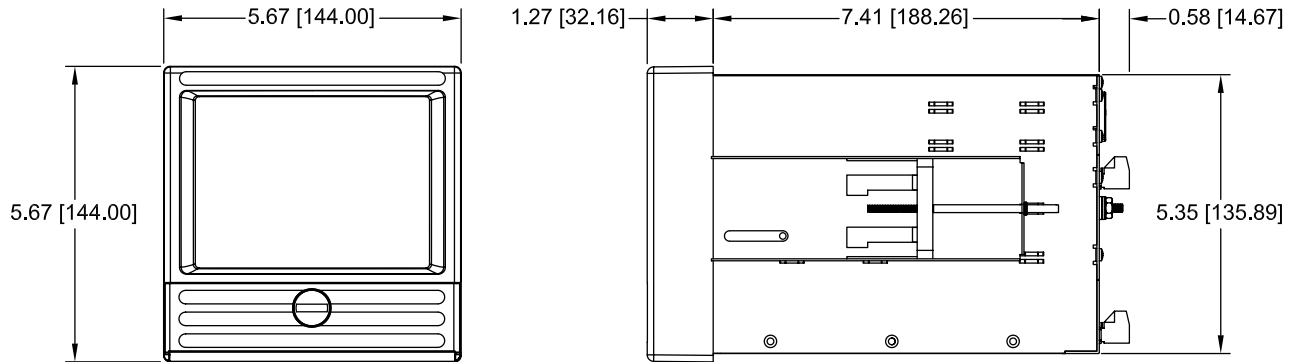

Figure 2-1 Recorder Dimensions in Inches [mm]

**WARNING:** Do not use this instrument in any manner inconsistent with these operating instructions or under any conditions that exceed the environmental specifications stated.

## 2.2.1 Panel Mounting

The Recorder should be mounted in a vertical panel to ensure proper operation. Ensure you have the proper clearances and proceed as follows:

- 2.2.1.1 Cut a panel opening 5.43" x 5.43" [138 mm x 138 mm].
- 2.2.1.2 Remove any packaging material from the Recorder. Always handle the unit carefully to avoid damaging the LCD display or scratching the display surface.
- 2.2.1.3 Remove the locking bars from the Recorder enclosure and ensure the gasket is not twisted on the enclosure.
- 2.2.1.4 Insert the Recorder **rear end first**, into the panel opening from the front of the panel as shown in Figure 2-2. Ensure that the gasket is between the front bezel of the Recorder and the front panel.

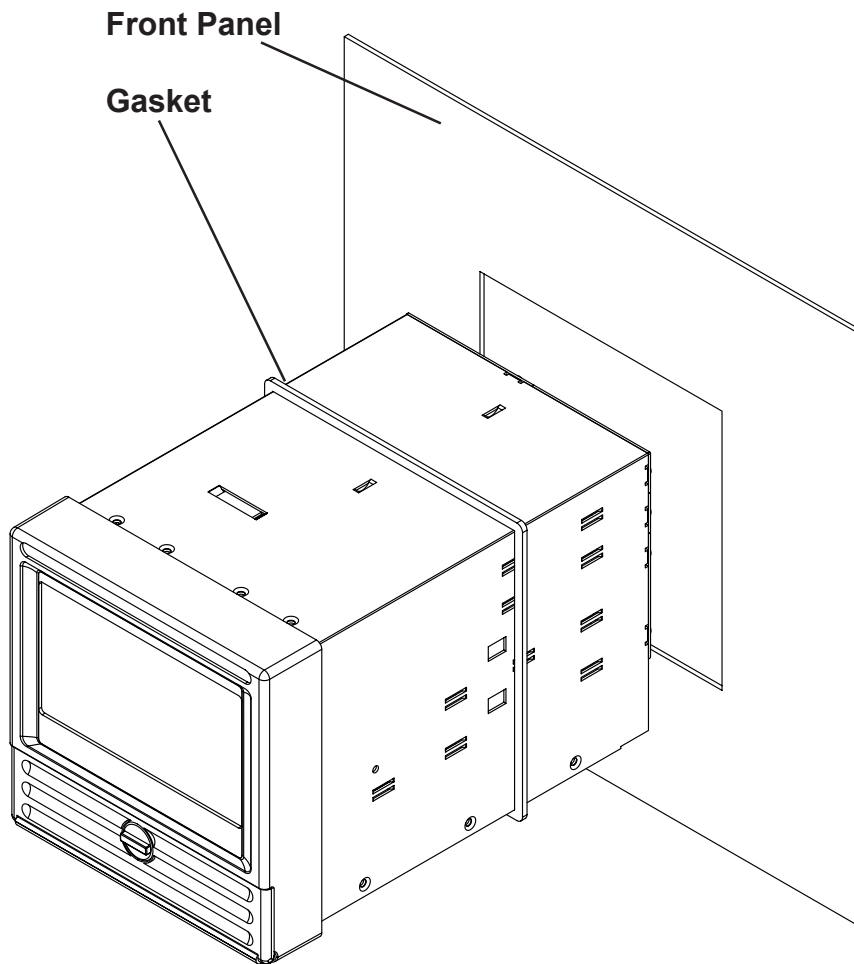
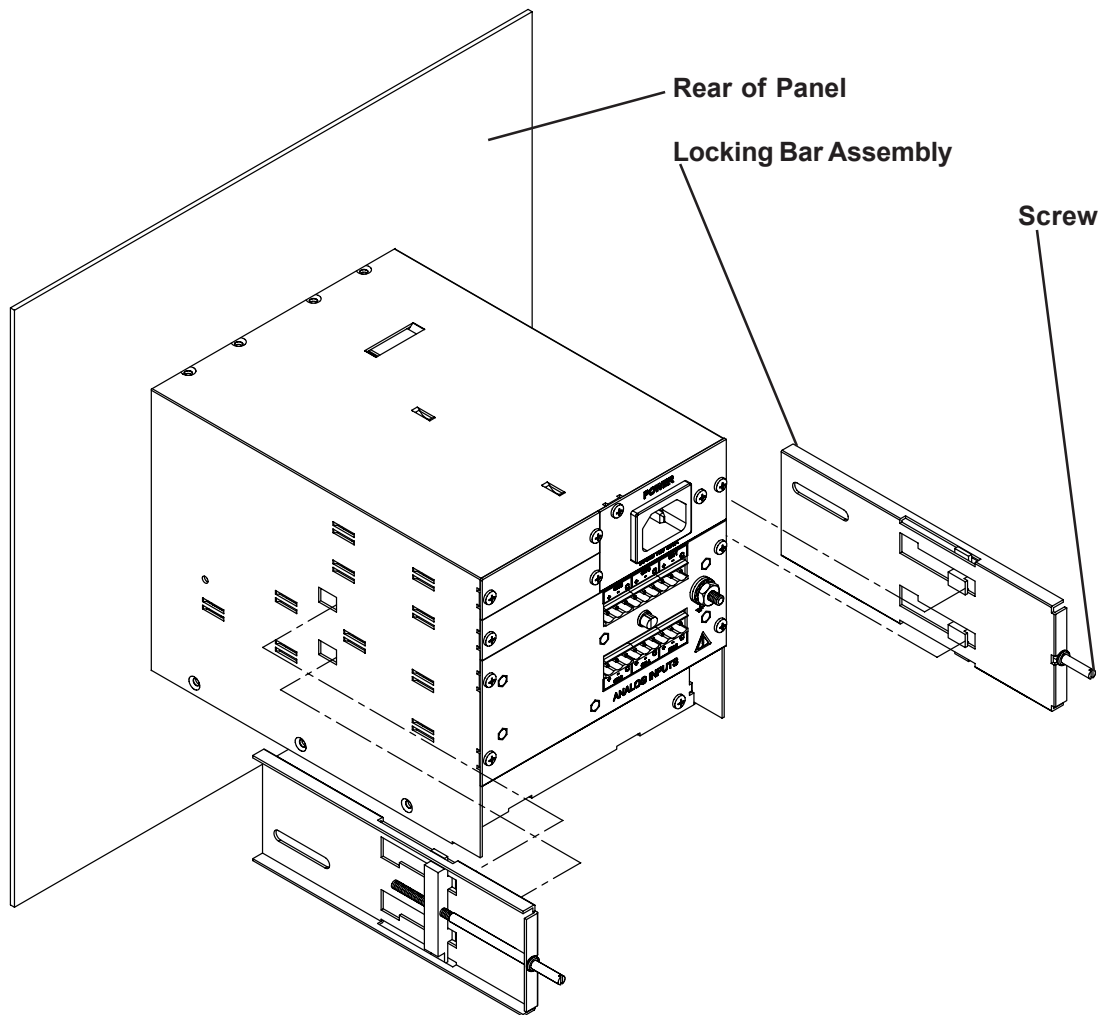

Figure 2-2 Front Panel Insertion



**2.2.1.5** With the Recorder held firmly in place against the panel, install one of the locking bar assemblies by sliding the locking bar notch into the slot on the side of the Recorder enclosure as shown in Figure 2-3.



**Figure 2-3 Rear View Panel Installation**

**2.2.1.6** Using a slotted screwdriver, tighten the screw until the locking bar is just pressing against the panel.

**2.2.1.7** Install the other locking bar assembly into the slot on the opposite side of the Recorder enclosure and tighten as before.

**2.2.1.8** Using the screwdriver, tighten both screws so that the Recorder is held firmly in place. **Do not over tighten.**

## 2.3 Wiring Specifications and Procedures

### 2.3.1 Power Requirements

The Recorder operates on any voltage from **100 to 240 Vac +10%, 50/60 Hz** enabling it to be used in most countries. The maximum apparent power required by the unit is 35 VA.

### 2.3.2 Power Connections

**NOTE:** The Recorder is designed to be panel mounted and as such should be considered as permanently connected. Disconnection from the supply must be possible via a customer supplied switch or circuit breaker. This disconnection device must be included in the panel installation and should be clearly marked, in close proximity to the Recorder and easily accessible to the operator.

All connections to the Recorder are made to the Rear Terminal Panel. Any wiring carrying hazardous voltages must conform to all applicable local and national safety codes. AC Mains connection is via an internationally accepted IEC 320 AC mains connector or screw terminal (Figure 2-4 and Figure 2-5).

## WARNING



Ensure all mains power is turned off before proceeding with installation. This unit is provided with a mating connector for the ac power socket or with a compatible three wire grounded cable which may be terminated with a plug. Always ensure the ground wire (green or green and yellow) or ground pin of the plug, is connected to a low impedance safety ground (earth) within the ac power distribution system you are using. Always use the recommended mating connector and an approved three wire cable to connect this unit to the ac mains. Always provide a low impedance safety ground wire to the ground lug on the rear panel marked .

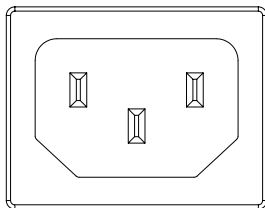

**Figure 2-4**  
AC Connector

Figure 2-4 shows the IEC 320 AC mains connector on the rear of the Recorder. The center pin is the ground termination. If a mating plug is provided, it will be marked with the Ground, LINE (L) or hot, and NEUTRAL (N) or return. In the United States, an approved cable with integral plug (NEMA 5-15 P) is provided. In some instances, a cable with no plug may be provided. In this instance, the user must connect an approved plug to the cable prior to connecting to the AC source.

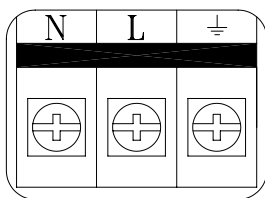

**Figure 2-5**  
Screw Terminal

Figure 2-5 shows the screw terminal power connections on the rear of the Recorder. The right terminal is ground, the center terminal is LINE (L) or hot and the left terminal is NEUTRAL (N) or return. The wire color codes are as follows:

COUNTRY	NEUTRAL (RET)	LINE (HOT)	GROUND
USA	White	Black	Green
EEC	Blue	Brown	Green/Yellow

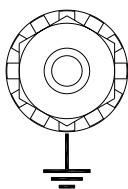

**Figure 2-5a**  
Ground Lug

Figure 2-5a shows the ground lug on the rear panel. This screw terminal must be connected to an earth wire which in turn is connected to the ground or earth of the AC power distribution system.

This unit is equipped with an AC mains fuse internally. If this fuse should blow, it generally indicates a serious problem with the Recorder. **THE FUSE SHOULD NOT BE REPLACED BY AN OPERATOR.** The fuse is a quick acting 5 x 20mm type rated at 2.0 Amps 250 VAC (~).

An optional AC mains plug retention clip is available - contact the factory.

### 2.3.3 Signal Input Wiring



**Signal input connections. Hazardous potentials may exist on signal input terminals which are floating with respect to case ground. These hazardous potentials may be on the rear terminal panel of your instrument. Any voltage potential at the signal source will exist on the instrument's respective signal input terminal (i.e. power generator stator winding).**

The Recorder accepts up to twelve direct inputs. Input connection is via plug in screw terminal connectors on the rear panel. Inputs can be mixed in any combination of thermocouple, RTD, milliamps, millivolts, volts or contact inputs. There is a common ground lug marked with a  $\perp$  for connection of signal cable shields or screens.

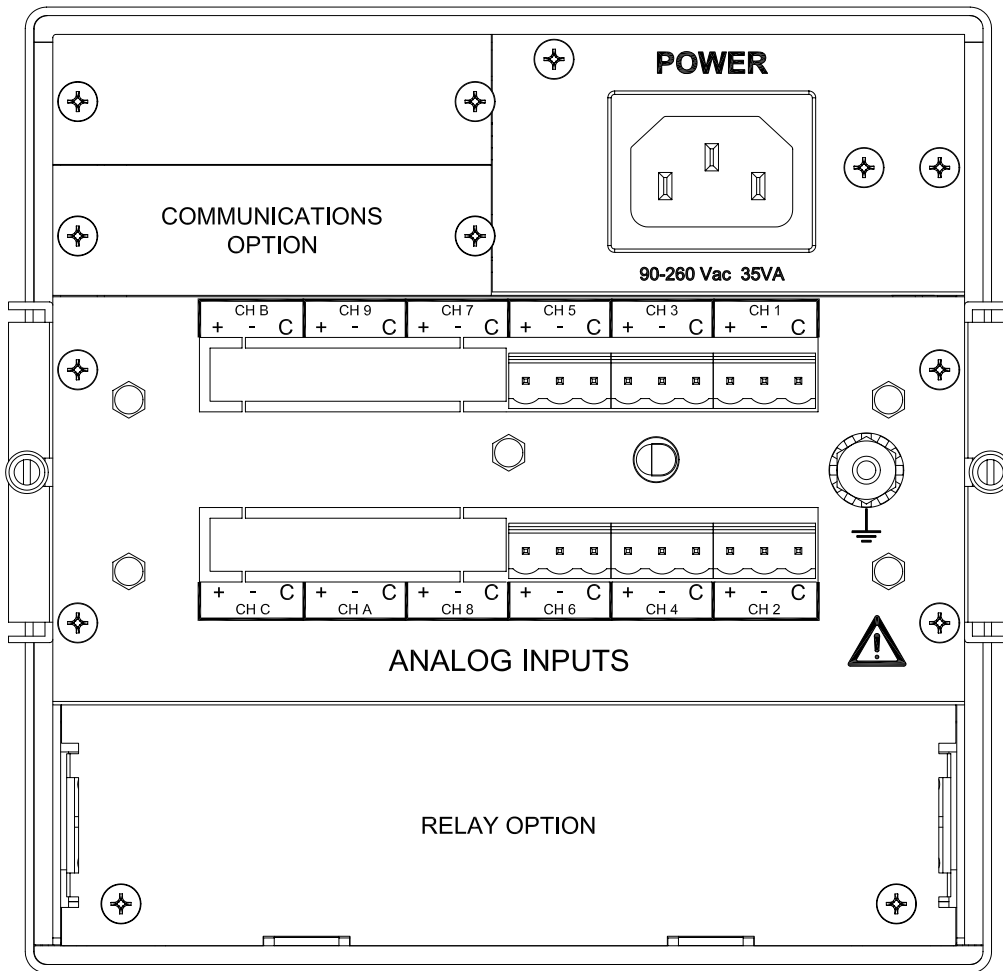

Figure 2-6 DC2000 Rear Panel Connections (12 Channel)

Read the following procedures prior to connecting inputs to the terminals.

**WARNING: Ensure the power is off before connecting signal inputs to the unit.**

The plug in screw terminal connectors are of the clamping screw variety, putting even pressure on the signal wire. It is therefore not necessary to terminate the wires with lugs, however you may do so if you wish. The maximum gauge wire that can be accommodated is 14 AWG or 2.5 mm<sup>2</sup>. You will need a small screwdriver and a pair of wire cutters and strippers. The use of shielded twisted lead wire is recommended to minimize electro-magnetically induced noise.

**WARNING: All unused inputs must have all contacts commoned together.**

**CAUTION: Never run signal and power or control wiring together in the same conduit. This is to prevent possible recording error due to induced signals between lines. Route signal wires away from power wires at the rear panel.**

**NOTE: Ground cable shields at one end only to eliminate the possibility of interference due to ground loop currents. When grounded transducers are used, the shield should be grounded at the sensor end only.**

### 2.3.3.1 Thermocouple Inputs

Thermocouple input connections are made as shown in Figure 2-7 T/Cs. Note that a link must be installed between the “-” terminal and “C” terminal.

### 2.3.3.2 Resistance Temperature Detector (RTD) Inputs

Two, three or four wire RTDs may be used for connection with cable compensation of  $\pm 50$  ohms. Refer to Figure 2-7 RTDs and manufacturing specifications.

### 2.3.3.3 Linear Inputs

Current inputs: 4-20 milliamps, 0-20 milliamps and 10-50 milliamps, using an external 50 ohm shunt. Voltage inputs:  $\pm 150$  millivolts,  $\pm 1.25$  volts,  $\pm 2.5$  volts,  $\pm 12.5$  volts,  $\pm 25$  volts and normally open/closed contact inputs. Note that a link must be installed between the “-” terminal and “C” terminal. Refer to Figure 2-7 Volts or mA for details.

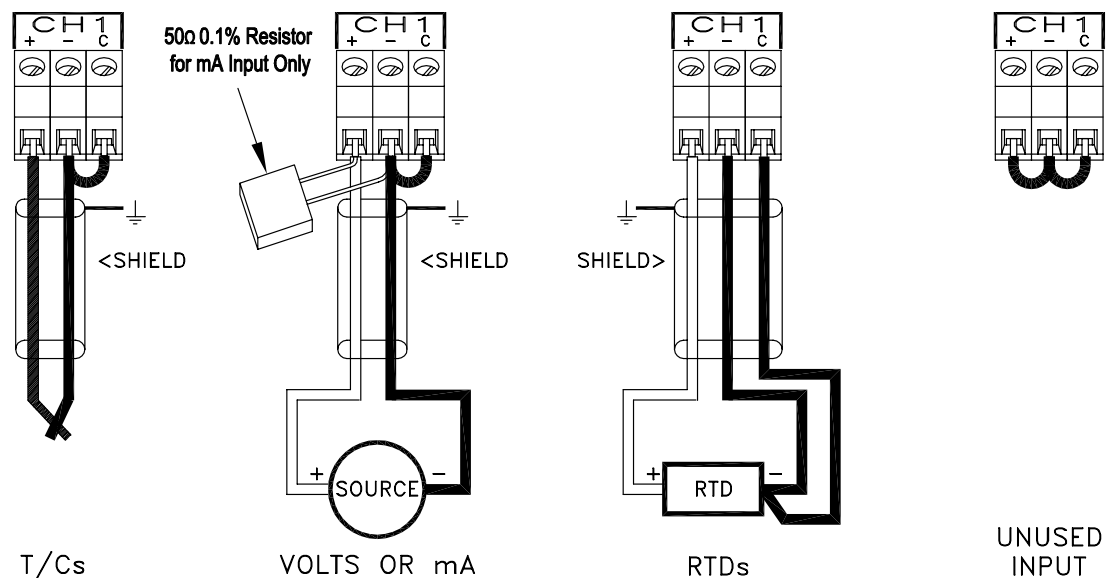

Figure 2-7 Thermocouple, RTD and Linear Inputs Wiring Detail

### 2.3.4 Relay Output, Contact Input

#### WARNING



To prevent the possibility of electrical shock, use extreme caution when wiring contact output connections. Hazardous potentials may exist on contact output terminals which are floating with respect to instrument ground. These hazardous potentials may be exposed on the rear terminal panel of your instrument. Any voltage potentials at the contact circuit will exist on the instrument's respective contact output terminals (i.e. line-powered circuits).

#### 2.3.4.1 Mechanical Relay Option

The Recorder may be equipped with an optional Digital Input Output Board which has three or six potential free Form C relay contacts and three opto-isolated digital inputs. A terminal block as shown in Figure 2-8 below is provided for the three alarm output Potential Free Form C connections: Normally Open (NO), Common (C), and Normally Closed (NC), and the three digital inputs which share a common. The relay contacts are capable of switching 125 Vac ~ at 0.5 Amp or 30 Vdc at 0.5 Amp. The potential free relay contacts are protected internally with 300 volt Metal Oxide Varistors (MOVs) to prevent contact arcing.

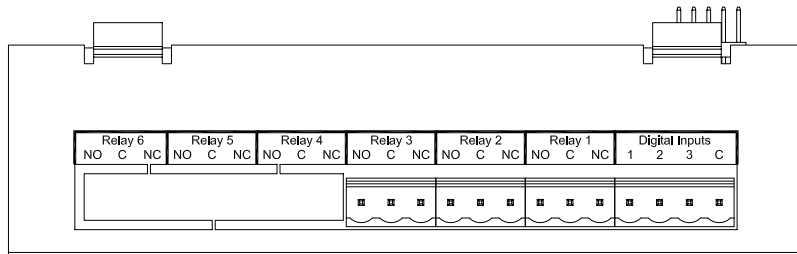

Figure 2-8 Mechanical Relay Connections (3 Channel Shown)

#### 2.3.4.2 Solid State Relay Option

The Recorder may be equipped with an optional Digital Input Output Board which has three or six solid state open collector outputs and three opto-isolated digital inputs. A terminal block as shown in Figure 2-9 below is provided for the alarm output connections. The output connections are polarized and are intended for DC operation only. Reverse polarity protection is provided and each output is fused at 1 Amp. The fuse is solid state and will reverse once the load is removed. The outputs are rated at 30 VDC at 0.5 Amp and are optically isolated from the Recorder.

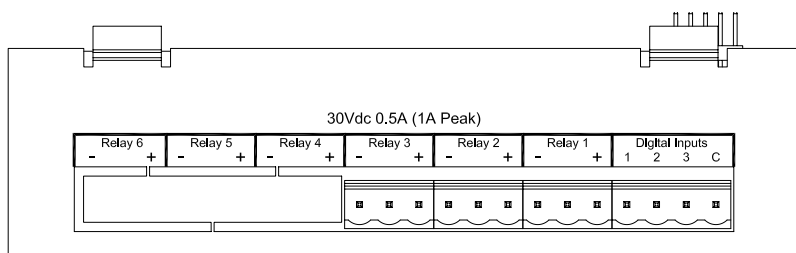

Figure 2-9 Solid State Relay Connections (3 Channel Shown)

#### 2.3.4.3 Opto-isolated Inputs/Outputs

The opto-isolated inputs require an external potential of 5 to 12 volts DC @ 10 milliAmps. The three inputs are isolated from the unit, but not from each other as they share a common. The positive voltage connects to the terminals marked 1, 2 or 3 and the common connects to the terminal marked C. It is possible to use potential free contacts to operate the digital inputs. This requires opening the unit and setting jumpers on the relay board. Refer to Appendix E - Setting the Jumpers for the 3 or 6 Channel Mechanical or Solid State Relay for details.

## 2.4 Serial Interface Option

Data can be accessed to download Configuration files or Data files using the RS232C option and a modem. The RS485 option allows the Recorder to be installed into an existing Modbus network or it can be used to connect up to thirty-one Recorders in series. A standard DB9 Female connector is required for the RS232 to connect to an IBM PC compatible computer using a null modem cable and the RS232 can support cable runs up to 50 feet [16 m]. The RS485 connection is via two wire (twisted pair) cable (a DB9 Female connector is required) and can support cable runs up to 4000 feet [1300 m].

The Serial Interface contains an isolated switching unit for RS232 and RS485 access with a standard DB9 Female connector. When switch 2 is in the ON position, RS485 is enabled. When switch 2 is in the OFF position, RS232 is enabled.

When more than one Recorder are connected in a series, it is necessary to apply a termination resistor on the last Recorder. Switch 1 in the ON position applies this necessary termination resistor and should be switched to the ON position only on the last Recorder in series.

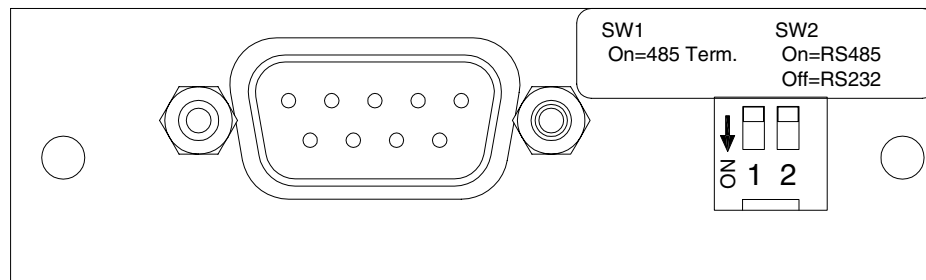

**Figure 2-10 RS232/RS485 Modbus**

All Serial Interface connections are made through the DB9 female connector.

The RS232 Connection to the DB9 female connector are as follows:

DB9 PIN	CONNECTION	DIRECTION
2	RxD Receive Data	In
3	TxD Transmit Data	Out
4	DTR Data Terminal Ready	Out
5	Common	N/A
7	RTS Request To Send	Out
8	CTS Clear to Send	In

The RS485 (Half Duplex Mode) Connection to the DB9 female connector are as follows:

DB9 PIN	CONNECTION	DIRECTION
6	B+ Positive	Input/Output
9	A- Negative	Input/Output

## 2.5 Ethernet Option

The 10BaseT Ethernet option allows direct connection to a LAN or WAN and the standard TCP/IP protocol enables the transfer of data over the Internet.

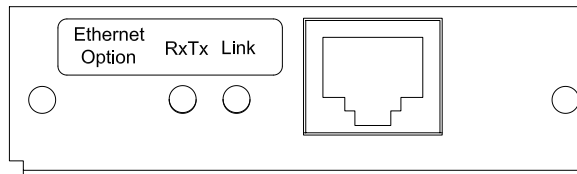

Figure 2-11 Ethernet Option

The RJ45 Connection for the Ethernet are as follows:

Receive	Differential Pair
3	RX-
6	RX+
Transmit	Differential Pair
7	TX-
8	TX+

Two LEDs on the rear panel show Ethernet activity. The Link LED indicates a good connection and the RxTx LED indicates communication activity.

## 2.6 Cleaning

The unit may be cleaned by wiping with a soft cloth. The front panel and display / keypad may be wiped with a slightly damp soft cloth containing soapy solution or a mild detergent. **Do not use any lemon based (citric acid) product to clean the display / keypad.**

## 2.7 Contrast Adjust (Monochrome Only)

The contrast or viewing angle of the monochrome LCD display can be adjusted from the side panel. If not adjusted correctly, the display may look dim, dirty, completely black, washed out or blank. Insert a small star or Phillip type screwdriver into the hole in the side panel as shown in Figure 2-12 and turn to adjust the display contrast. The adjustment potentiometer has a 270° rotation. **Do not apply excess pressure or attempt to turn it beyond the end stops.**

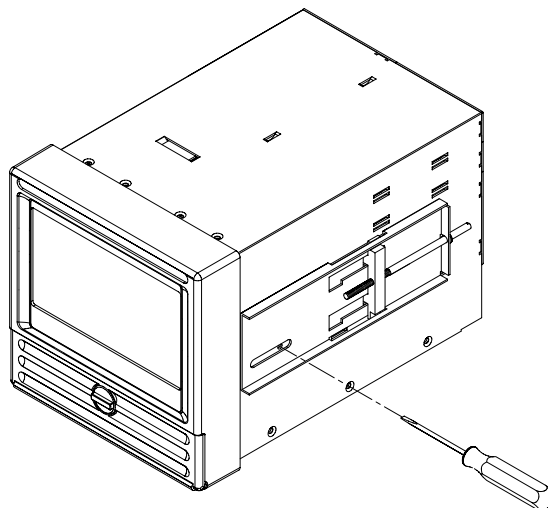

Figure 2-12 Contrast Adjust

# Chapter 3 Getting Started

3.1 Moving About the Screen .....	3-1
3.1.1 Status Bar .....	3-1
3.1.1.1 Disk Status .....	3-2
3.1.1.2 Status Line .....	3-2
3.1.1.3 Alarm Acknowledgment .....	3-2
3.1.2 Button Bar .....	3-3
3.1.2.1 VIEW Button .....	3-3
3.1.2.2 BROWSE Button .....	3-3
3.1.2.3 JOG Button .....	3-3
3.1.2.4 MENU Button .....	3-3
3.1.3 Graphics Area .....	3-4
3.1.3.1 Bar Charts .....	3-4
3.1.3.2 Digital Windows .....	3-4
3.1.3.3 Alarm/Event Data Window .....	3-5
3.1.3.4 Trend Chart Windows .....	3-5
3.1.3.5 Pop Up Windows .....	3-6
3.2 Getting to the Points .....	3-7
3.3 Using Chart Scales .....	3-8
3.4 Programming .....	3-9
3.5 Programming Time and Date .....	3-9
3.6 Programming Points .....	3-10
3.6.1 Point tag .....	3-10
3.6.2 Input Scale .....	3-11
3.6.3 Output Scale .....	3-11
3.6.4 Engineering Units .....	3-11
3.6.5 Chart Scale .....	3-11
3.7 Programming Point Scales .....	3-12
3.7.1 Scale Type .....	3-12
3.7.2 Scale Ends .....	3-12
3.7.3 Scale Units .....	3-12
3.8 Recording Data .....	3-13
3.8.1 Using the Recorder to format a floppy disk or CompactFlash™ card. ....	3-13
3.8.2 Programming the unit for recording .....	3-14
3.8.2.1 Setting Which Points to Record .....	3-14
3.8.2.2 Setting the Record Rate .....	3-14
3.8.2.3 Setting the Fill Mode .....	3-14
3.8.2.4 Setting the Data Mode .....	3-15
3.8.2.5 Arming Record Data on/off .....	3-15
3.8.3 Starting Recording .....	3-15
3.8.4 Stopping Recording .....	3-16
3.9 Hot-Swap .....	3-16
3.10 Changing File Names .....	3-16



3.11 Setting the Disk Full Alarm .....	3-17
3.12 Saving and Loading Configuration Files .....	3-17
3.13 Browsing, Searching, Compressing and Expanding Data .....	3-18
3.13.1 File Browsing .....	3-19
3.13.2 Searching Data By Value .....	3-19
3.13.3 Searching Data By Time .....	3-20
3.13.4 Interactive Browse Mode .....	3-20
3.13.5 Compressing and Expanding Data .....	3-21

# CHAPTER 3

---

The Instrument is an extremely versatile solid state data recorder. It has a liquid crystal display capable of complex graphical representation and either a floppy disk drive or CompactFlash™ card drive for data storage. The unit is easily programmable, and the average user will probably never need to use most of the features or functions available in the Recorder. This chapter will give the user a brief system overview and guide the first-time user in a simplified setup which will enable you to begin recording with the least amount of effort.

## 3.1 Moving About the Screen

The Recorder has an LCD graphics screen that also acts as a touch keypad. Areas of the screen are active as push buttons. The exact areas that are sensitive depends on what is currently being displayed. The user has only to lightly touch the screen area depicting the button to activate a particular function. If the Beeper is turned on, the unit will provide audible feedback, as a short beep, each time a “button” press is registered. The default display is shown in Figure 3-1 below.

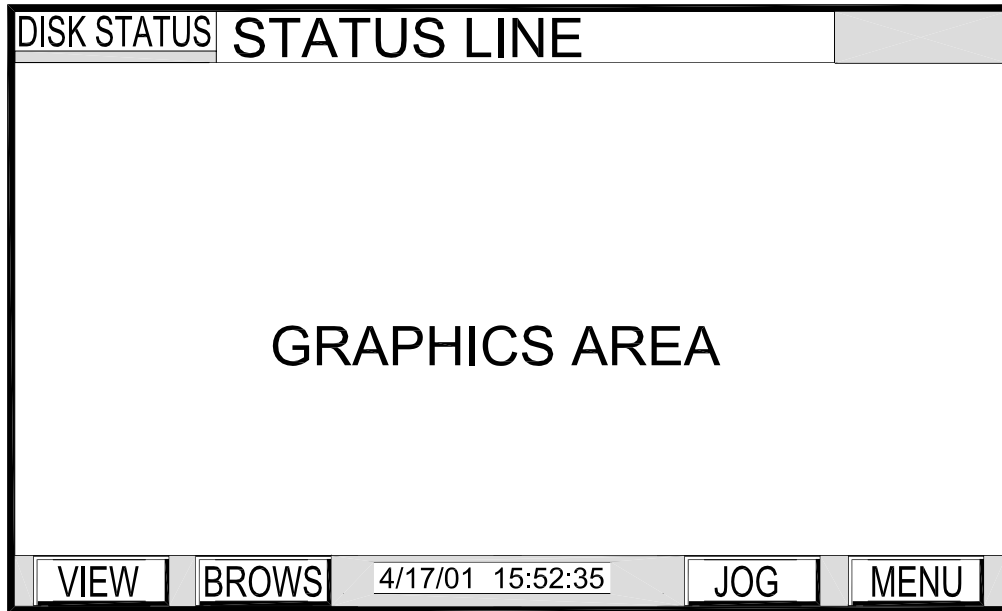

Figure 3-1 Recorder Screen

The screen is divided into three distinct areas: the **Status Bar**, across the top of the screen; the **Button Bar**, along the bottom of the screen (containing the time / date stamp); and the **Graphics Area** between them.

### 3.1.1 Status Bar

The **Status Bar** (see Figure 3-2) consists of two sections: **Disk Status** and **Status Line**. Also, an Alarm **ACK**nowledgment button (not shown) will flash on top of the **Disk Status** section when there is an alarm condition.



Figure 3-2 Status Bar

### 3.1.1.1 Disk Status

On the left hand side of the **Status Bar** is the **Disk Status** information (disk info). This displays the current condition of the disk/card that is currently being used to save data. When the unit is not recording, this area shows **REC OFF**. When the Recorder is recording, it displays **REC↑** for fast rate recording or **REC↓** for slow rate recording, as well as **XX%** used, where **XX** is the amount of disk space already recorded.

The following messages may appear in the **Disk Status** area:

<b>OFF 15%</b>	Unit is not recording to disk/card, Record Mode is OFF - Disk/card is 15% full
<b>REC↑ 15%</b>	Unit is recording to disk/card in HIGH speed mode - Disk/card is 15% full
<b>REC↓ 75%</b>	Unit is recording to disk/card in LOW speed mode - Disk/card is 75% full
<b>FORMAT</b>	Disk/card is being Formatted
<b>SAVE CFG</b>	Saving Configuration to disk/card
<b>LOAD CFG</b>	Loading Configuration from disk/card
<b>TRIG 75%</b>	Unit is waiting for an Event or Alarm to turn the Record Mode on - Disk/card is 75% full

### 3.1.1.2 Status Line

The middle section of the **Status Bar** is the **Status Line** which displays the Point information, Alarm information, rear terminal Junction Temperature or Unit Tag. The user can change the **Status Line** to display the Points, Alarms or Junction Temperature using the **DISPL** (Display) **Menu** (see Section 4.2.1). By default, when the unit is powered up, the **Status Line** will show the Unit Tag (identification) information. The powerup default can be changed to Unit Tag, Auto Jog, Point, Alarms or Junction Temp using the **Powerup disp** option under the **PROG** (Program) **Menu** (see Section 5.4.3).

The following examples show how information is displayed in the **Status Line**:

Point information:

Point No.	Value	Units
1	0.496	VOLTS

Alarm information:

Point No.	Value	Alarm Type/Number
1	0.496	H1

There are 5 possible alarms per channel and 3 types of alarms: H = High, L = Low and R = Rate. Therefore, H1 = High Alarm #1. If more than one alarm is active they will cycle through on the **Status Line**. If there are no alarms active, the **Status Line** will display "NO ALARMS". If the Alarm check option is turned off, the **Status Line** will display "ALM CHKS OFF".

Junction Temp:

Temp	24.8 °F
------	---------

Unit Tag:

This is a UNIT TAG
--------------------

A Unit Tag can be up to 20 characters long and will display in the **Status Line** as entered by the user. To enter a Unit Tag refer to Section 5.4.3.1.

### 3.1.1.3 Alarm Acknowledgment

The **ACK** button will appear on top of the **Disk Status** section on the left side of the **Status Bar** when there is an alarm condition. The **ACK** button is only present when there is an alarm condition, at which time it blinks until the user presses it to acknowledge the alarm condition. Pressing the **ACK** button will also reset any output relays if this option is installed and programmed. The **ACK** button will always be the top most button, always rising to the surface when covered by other items such as menus. This allows the user to acknowledge an alarm at any time, even while in the programming mode.

### 3.1.2 Button Bar

The **Button Bar**, located on the bottom of the screen, contains “buttons” used to operate the unit. When the unit is powered up, the **Main Button Bar** is shown (see Figure 3-3). The **Main Button Bar** has four buttons: **VIEW**, **BROWS**, **JOG** and **MENU**. The date and time are continuously displayed in the middle of the **Main Button Bar**. The date is shown numerically in either American (Month/Day/Year) or (European Day/Month/Year) format. Refer to Section 5.4.2 to program the date format.

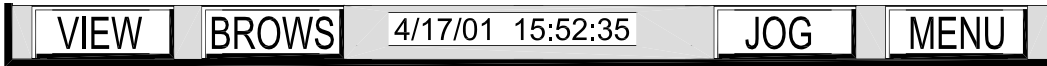

Figure 3-3 Main Button Bar

#### 3.1.2.1 VIEW Button

The **VIEW** button enables the user to scroll through the selectable display options in the **Graphics Area** of the screen (see Section 5.4.7). These views might be charts, bar graphs, digital windows, alarm/event information or combinations of these. Each time the **VIEW** button is pressed, the next view is presented.

#### 3.1.2.2 BROWSE Button

The **BROWSe** button is only displayed on screen views that can actually be browsed, which are the full screen Trend Chart Window and the full screen Alarm/Event Data Window. The user can choose to browse **RAM** (Random Access Memory) which is the screen trace data, or **FILE**, in which case a file menu will be presented so that the user can choose a file from the disk/card. The **BROWSe** button also allows the user to **SEARCH** historic data by **VALUE** or **TIME**, as well as **COMPRESS** data in time.

Pressing the **BROWSe** button puts a freeze on the real time display and allows the user to scroll back in time to browse through historical data that has passed off the screen or has been recorded previously, even on another machine. The actual Chart screen browse buffer is dependent on the memory options installed, the number of traces being displayed and the effective Chart speed. With the standard buffer, a Chart speed of one inch per hour with four traces active, it is possible to browse back approximately 140 hours (5½ days). The user may choose to browse files on the disk/card rather than the current memory buffer even though the unit is currently recording. The user can then browse files that had been recorded earlier, or may even browse the file that is currently being recorded. Once the data has been recorded to disk/card, it is possible to use the file browser or the PC and the optional *Companion Software* to view data as far back as the start of recording, irrespective of how long that may be, within the constraints of disk/card capacity.

#### 3.1.2.3 JOG Button

The **JOG** button is used to switch between channel data. At any time the user can press the **JOG** button to display point data in the **Status Line**. Each time the **JOG** button is pressed the next point data is displayed.

#### 3.1.2.4 MENU Button

When the **MENU** Button is pressed, the **Command Menu Button Bar** appears (see Figure 3-4) allowing the user to change **DISPL**ay features, **PROG**ram the unit and set **FUNC**tions. Refer to Chapters 4 and 5 for details.



Figure 3-4 The Command Menu Button Bar

The **Button Bar** will change depending on the mode and the buttons pressed. Certain key buttons will always be displayed in the same place, such as the **ENTER** Button on the left and the **EXIT** button on the right, allowing rapid movement through menus.

### 3.1.3 Graphics Area

The **Graphics Area** is used to display various information in different formats including Bar Charts, Digital Windows, Alarm/Event Data or Trend Charts. The **Graphics Area** view is changed by pressing the **VIEW** button on the **Main Menu Button Bar**. The user can also choose whether certain views are horizontally or vertically oriented (see Section 5.5.4 for details).

#### 3.1.3.1 Bar Charts

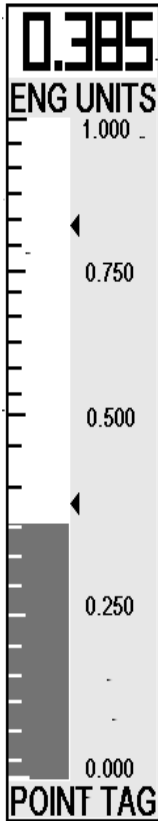

**Bar Charts** can be displayed on their own or combined with other windows on a split screen. Up to twelve **Bar Charts** can be displayed at a time. The user can select to display bar graphs either horizontally or vertically. The format of the vertical bar graph is shown opposite in Figure 3-5. The very top of the bar has the actual/real time digital value of the point, in this case 0.385. Immediately below this are the Engineering Units (i.e. SECS) which can be a maximum of five characters. At the very bottom of the bar graph is the Point Tag which is a ten character description of the point.

**NOTE:** Not all characters can be displayed on the **Bar Chart**.

Between the ENG UNITS and POINT TAG is a bar that represents the actual value as a function of the full scale value. To the right of the bar are scale values. The alarm setpoints, if any are set, are indicated on the bar by a “◀” in the text area. If any alarm is active, the bar will be blinking. Refer to Chapter 5, Section 5.6 for programming of the Engineering Units, Point Tag, Alarm setpoints and scaling.

**NOTE:** If the bar chart is horizontal, the full scale is sideways with the scale values along the top and the Engineering Units to the right of the scale bar. The actual value is in the top right corner and any alarm setpoints are indicated on the bar by a ↓ in the text area.

Figure 3-5 Bar Chart

#### 3.1.3.2 Digital Windows



Figure 3-6 Digital Window

**Digital Windows** can be displayed on their own or combined with other windows on a split screen. Up to twelve **Digital Windows** can be displayed at a time. The format of the Digital Window is shown opposite in Figure 3-6. The large numbers in the center of the window are the real time point value. Above this point value is the Point Tag shown as POINT TAG which is a ten character description of the point. Below the point value is the Engineering Units (i.e. SECS) which can be a maximum of five characters. Refer to Chapter 5, Section 5.6 for programming of the Engineering Units, Point Tag and scaling of the digital value.

**3.1.3.3 Alarm/Event Data Window**

Alarms/Events Data Log				
Alarm Check On				
<i>Date</i>	<i>Time</i>	<i>Point</i>	<i>Status</i>	<i>Value</i>
1/07/03	14:51:33	P5	FALSE	0.000
1/07/03	14:48:15	P1	*	0.504
1/07/03	14:45:00	P6 HI	Reset	17.427
1/07/03	14:35:27	P6 HI	Peak	23.568
1/07/03	14:20:15	P1	HIGH 1	0.892
1/07/03	13:22:56	S3	CLOSED	
1/07/03	13:22:56	S2	CLOSED	
1/07/03	13:22:56	S1	CLOSED	
1/07/03	13:22:56		POWER UP	
1/06/03	07:34:28		POWER DOWN	

**Figure 3-7 Alarm/Event Window**

The **Alarm/Event Window** is used to display Alarms, Events and Reset information. The format of the **Alarm/Event Window** is shown opposite in Figure 3-7.

The first line is the title bar followed by the Alarm checking status on the second line. If Alarm checking is enabled the second line will indicate "Alarm Check On". Otherwise, it will indicate "Alarm Check Off" in which case no alarms will occur. Refer to Section 4.2.3.7 to change the Alarm checking status.

The format for any entry in the Alarm/Event file is - *Date, Time, Point, Status, Value*. The *Date* is shown as Month/Day/Year, the *Time* is shown as Hours:Minutes:Seconds, and the *Point* value is shown as Px, where x is the Point number.

The *Status* information or message depends on the type of Alarm/Event. For linear inputs, the Alarm/Event Status can be HIGH 1 or LOW 2, where the number is the alarm count up to a maximum of 5. For conditional inputs, the Alarm/Event Status can be OPEN, CLOSED, TRUE or FALSE where the value is the actual value at the time the alarm was registered. An Alarm/Event Status of "\*" is an Alarm returned to normal condition at the time the point came out of alarm. Resettable points, such as totalizers, will show the Status as RESET with the actual value at the time of reset. Some Resettable point types will have two entries (see P6 above). The first entry is the date and time that the high peak occurred and the peak value. The second entry, above it, is the actual time the reset occurred and the value at that time.

**NOTE:** Resettable points will not print unless the Reset Print option is turned on. See Section 5.6.5.13.3.

The *Value* shown is dependent on the Event. The Event can be an Alarm, an input contact closure (Event) or a Reset, either automatic or manual.

For external events via the digital inputs, the user can define separate Status messages, up to ten characters long, for each of the three inputs, one for input activated (Close) and one for input deactivated (Open). These user defined Event messages will appear in the **Alarm/Event Window** log as - *Date, Time, Switch number (Sx), Status* (Event message). Default Event messages are CLOSED and OPEN as seen in the data log example above. Refer to Section 5.9.3 to program Event messages.

**3.1.3.4 Trend Chart Windows**

The **Trend Chart Window** looks like a traditional "paper" recorder on the screen. It has traces or pens and emulates the paper chart, moving the "paper" across the screen. There may be as many as twelve pens on the chart at a given time. Refer to Section 5.5.3 to assign pens to the chart. The trending direction can be changed to move horizontally (right to left) or vertically (top to bottom). Refer to Section 5.5.4 to change the trending direction. Figure 3-8 on the next page shows a **Trend Chart Window** in the vertical mode.

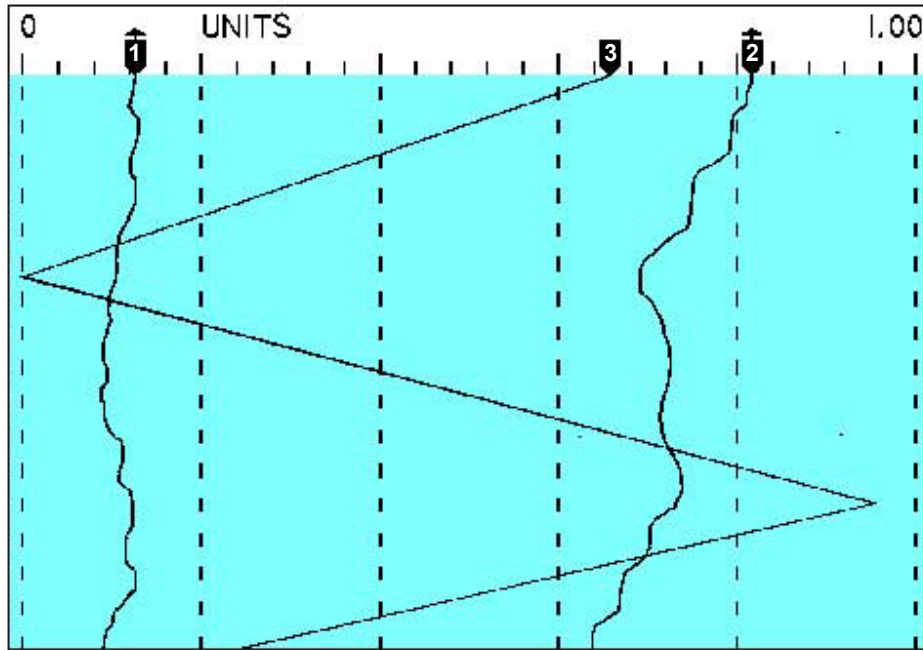

Figure 3-8 Vertical Trend Window

The vertical trend chart has the scale UNITS and scale value end points across the top. In the example above, the 0 and 1.00 scale value end points indicate that the trace has a value of zero when it is hard to the left and 1.00 when it is hard to the right. Below the scale units and end points are the pen pointers with one pointer for each pen that is on. These track the real time value of the points and identify the origin of the trace. There is a marker on the top of the pen pointer when the pen refers to the current scale (pens 1 and 2). When the scale changes, so will the markers on the pen pointers.

Below the pen pointers are grid lines, both horizontal and vertical. In the above example, the vertical grid spacing is a function of the divisions on the chart scales. The horizontal grid lines indicate the scales for the chart. If there is more than one scale set, they will alternate and can be manually toggled through by pressing the middle of the scale (top center of the display).

### 3.1.3.5 Pop Up Windows

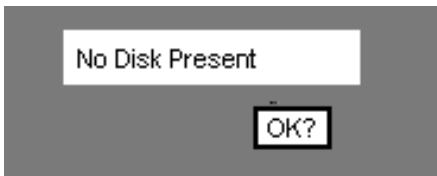

Figure 3-9 Pop Up Window

**Pop Up Windows** are windows that appear momentarily over any existing window to inform the user of a problem or of a background task being completed. They require a user response, normally pressing the “OK?” button, to acknowledge the message.

### 3.2 Getting to the Points

The Instrument is a 15 point Recorder of which up to twelve channels may be direct or real world inputs. These are typically voltages or currents. Any channel not being used to record or display live inputs may be used as a computational channel. Inputs can be conditioned or scaled to display any range of engineering units. Refer to Figure 3-10 below.

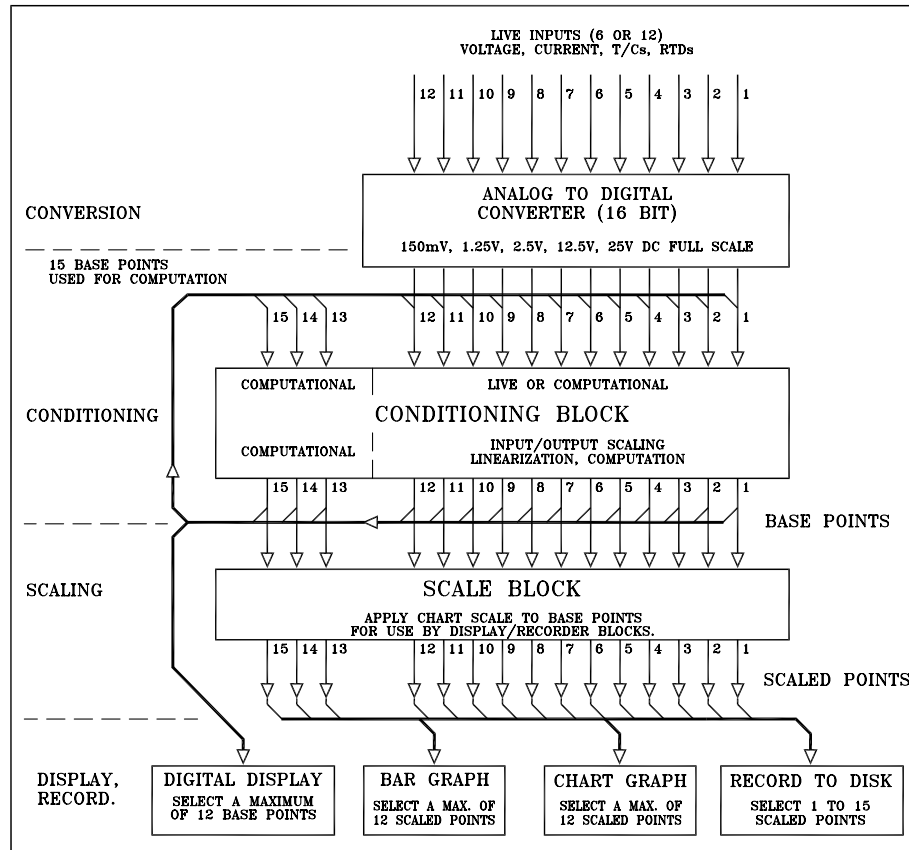

Figure 3-10 Data Flow

There are four distinct levels of data handling, namely conversion, conditioning, scaling and display/record. Conversion applies only to live inputs and is the process of converting real world analog signals into a 16-bit digital value that can be used by the Recorder. There are five full-scale ranges for all conversions 150 mV, 1.25 V, 2.5 V, 12.5 V and 25 V DC. The converted values pass to a conditioning block which converts the binary value, which is effectively a percentage of full scale, into a value useful to the user. Conditioning includes converting the binary value into a representative voltage, conditioning and linearizing this voltage to represent for example, a real world temperature as might be input by a thermocouple or RTD, and applying any other computation as required. The conditioning block handles 15 channels. The outputs from the conditioning block are referred to as **base points** and may be fed back to the inputs of the conditioning block to form the basis (base point) for other base point computations. This includes tracking peak or valley values, doing moving averages, timed averages, difference, totalization or any other user-entered equation.

The input to any channel in the conditioning block can be any one of the base points, or it can be the live inputs. Live inputs can have input and output scaling applied in the conditioning block unless this is predefined by the nature of the input (i.e. thermocouples). An example of input/output scaling is given in section 3.3.



The outputs of the conditioning block are the values represented in the Digital Windows and are real-world engineering values. The outputs of the conditioning block are also fed through to a **scale block** where a **chart scale** is applied to each point. The chart scales determine what part of the full scale range will be used by the display/record block. There are two sets of 8 scales available to the user. The second set is an alternate set which can be applied to the base points in place of the normal set when triggered by an external event. Each chart scale may be applied to any one or more of the base points to provide an output **scaled point**. These scale points are then applied to the display/record block which consist of the visual information or recorded information that the user requires. Up to twelve scaled points are applied to the bar graph display. Up to twelve may be displayed on the chart and up to fifteen may be recorded to disk/card. Note that points recorded to disk/card need not be the same as points displayed on the bar graph or the chart, however, in the case of the chart, any point which is not recorded to disk/card will have limited browse capability. The user should also be aware that applying scaling other than full scale output to recorded data limits the data to the range between scale end points. It is possible to store the base point with different scaling than is used to display it on the chart using one of the computational channels.

### 3.3 Using Chart Scales

To better understand the use of input and output scaling, and how scaling base points affects the data, consider the following example, highlighted by Figure 3-11.

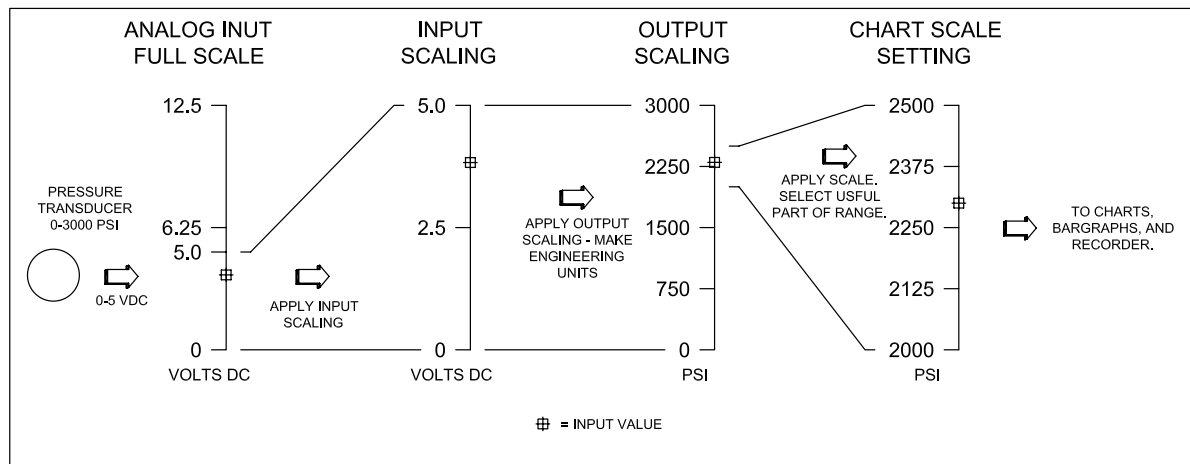

Figure 3-11 Scaling Example

Assume the user wants to record the output from a pressure transducer which gives a 0 to 5 Vdc output signal. This coincides to a pressure of 0 to 3000 pounds per square inch (PSI). The process being monitored typically runs at 2200 PSI  $\pm 10\%$ ; this is the area of interest. The output of the transducer which peaks at 5 V is connected to live input channel 1 and the 12.5 Vdc full-scale range is selected to cover this range. Since the maximum input voltage will be only 5 V on a 12.5 Vdc range, use the **input scale** option to set the low end at 0.0 Vdc, and the high end at 5.0 Vdc. To convert this directly to PSI, the **output scale** is set at low point 0.0 and high point 3000.0. The **base point** now becomes 0 to 3000 for an input of 0 to 5 Vdc, scaled linearly across the range. The engineering units can be set to PSI and the point tag can be set to any label that identifies the process. For more details refer to Section 5.6. Apply scale A to the base point; this too is explained in Section 5.6.

It is then necessary to define **chart scale A** to suit the requirement (see Section 5.5.2). In order to maximize the display resolution, the user is interested in pressure ranges from 2000 to 2500 only. Scale A is thus set for a low end of 2000, a mid-range of 2250 and a high end of 2500. This scale point is now assigned to the bar graph and the chart graph. The chart will thus display from 2000 to 2500 as will the bars, maximizing the display resolution for the value of interest. The user can choose to record this particular value, in other words, what you see on the chart is what is recorded to disk/card, values from 2000 to 2500. Or, if so desired, the user can choose to record a second point which will show pressures from 0 to 3000. To do this, use the channel 1 as a base point for a computational channel and multiply this value by 1 which is then recorded to disk/card.

## 3.4 Programming

While the unit may be programmed remotely, the exercises in the following sections deal with manually programming the unit from the front panel using the display and the touch screen keypad. Various buttons and keys will be presented on the display. The user simply makes a choice by pressing the appropriate key or button. In some instances, direct selection is not possible but rather a series of choices is made by using an **UP (↑)** or **DOWN (↓)** button and pressing the **ENTER** or **EXIT button**. Once programming is complete, the unit automatically “learns” the current setup which is stored in nonvolatile memory and remembered indefinitely.

When powering up the unit for the first time, or if the data in the nonvolatile memory should become corrupt, the user will be asked to perform a Smart Initialize; select **No**. The user will then be requested to perform a full initialization. Select **Yes** at this stage to reset all values to the default.

There are many parameters that can be programmed including: time and date, the display, the virtual chart and pens, the points, the recording capability, the alarms, the digital outputs and the communication port.

## 3.5 Programming Time and Date

To program the Time and Date:

1. Press the **MENU** button on the **Main Button Bar** to bring up the **Command Button Bar**.
2. Press the **PROG** button to enter the program mode, which will bring up the Program menu along the left of the screen.
3. Press the **UP (↑)** or **DOWN (↓)** button until **Time & Date** is highlighted.
4. Press the **ENTER** button which will display the current time in 24 hour format in the top right of the screen.
5. If the time is correct, press the **ENTER** or **YES** button and skip to step 11.
6. To change the time press the **NO** button and a numeric keypad will appear enabling you to enter the current time in hours.
7. Use the **NUMERIC** buttons to enter the hours. The **SPC** (Space) button will clear any digit and the **LEFT** or **RIGHT** buttons will move the cursor to the left or right digit. Once you have selected the correct number of hours, press the **ENTER** button. If an illegal value is entered, a window will appear with the message “OUT OF LIMIT” and you must press the **OK?** button and enter a different value.
8. Enter the number of minutes and press the **ENTER** button.
9. Enter the number of seconds and press the **ENTER** button.
10. The new current time will display. If the time is correct, press the **ENTER** or **YES** button.
11. The current date will display.
12. If the date is correct, press the **ENTER** or **YES** button.
13. To change the date press the **NO** button and a numeric keypad will appear enabling you to enter the current month.
14. Enter the current month and press the **ENTER** button.
15. Enter the current date and press the **ENTER** button.
16. Enter the last two digits of the current year and press the **ENTER** button.
17. The new current date will display. If the date is correct, press the **ENTER** or **YES** button to return to the Program menu. To change the date, go back to step 13.
18. Press the **EXIT** button twice to return to the default display.

## 3.6 Programming Points

The **points** are the input or calculated channels that are assigned to the display or are recorded. It is recommended to clear all points before reassigning them in case there is any incorrect point data stored.

To clear all points:

1. From the **Main Button Bar** press the **MENU** button and then the **Upper right corner** to get the **Hidden** menu.
2. Use the **UP (↑)** or **DOWN (↓)** button to highlight **Initialize** and then press the **ENTER** button.
3. Use the **UP (↑)** or **DOWN (↓)** button to highlight **Clear points** and then press the **ENTER** button.
4. You will then be asked whether or not you wish to “clear?” the points. Press the **ENTER** or **YES** button.
5. Press the **EXIT** button twice to return to the **Command Menu Button Bar**.

To program a point:

1. From the **Command Menu Button Bar** press the **PROG** button.
2. Use the **UP (↑)** or **DOWN (↓)** button to highlight **Points** and then press the **ENTER** button.
3. Use the **UP (↑)** or **DOWN (↓)** button to highlight **Prog point** and then press the **ENTER** button.
4. You will then be presented with an alphanumeric keypad and asked which “point?” you wish to program (1-9 or A-F). For this example, press the **1** button and then press the **ENTER** button.
5. Use the **UP (↑)** or **DOWN (↓)** button to highlight **Setup pt** and then press the **ENTER** button.
6. You now have a selection of various ways in which this point can be programmed. These include **Linear**, **Industrial square root (Ind sqrt)**, **Log linear**, **thermocouple (T/c)**, **Rtd**, **Calculated**, **Conditional**, or **External**. To program a **Linear** point in this example, use the **UP (↑)** or **DOWN (↓)** button to highlight **Linear** and then press the **ENTER** button.
7. You now have to choose the full scale input range for this point. Program this point for one volt full scale input by using the **UP (↑)** or **DOWN (↓)** button to highlight **1.25V** and then pressing the **ENTER** button.
8. You will now be presented with the **Point Setup** menu that enables programming of various options pertaining to this particular point in the one volt full scale mode. These include the **Point tag**, **Input scale**, **Output scale**, **Exc. Currents**, **Filter**, **Engineering units**, **Alarms**, **Chart scale**, and **Output mode**. Refer to Chapter 5 for detailed information on the items not covered below.

### 3.6.1 Point Tag

The **Point tag** is an alphanumeric indication of what the point represents and is generally located or displayed at the bottom of the bar graph or on the chart itself. This information is also stored to disk/card to uniquely identify the point.

To add a **Point tag**:

1. From the **Point Setup** menu use the **UP (↑)** or **DOWN (↓)** button to highlight **Point tag** and then press the **ENTER** button.
2. You will be presented with the first page of an alphanumeric keypad. There are four pages available which include all the upper and lower case alphabet characters, numerics and various signs and symbols for programming engineering units. Up to ten characters for the point tag may be entered (only eight will be displayed on the screen). To access characters on another page, simply press the **PAGE** button. The space button is “**SPC**”, the **LEFT (←)** and **RIGHT (→)** buttons move the cursor to the position you wish to edit or enter.
3. Use the letter/symbol buttons to program the **Point tag** as “**EXAMPLE**” and then press the **ENTER** button to return back one menu. To exit without programming a tag, press the **EXIT** button to return to the **Point Setup** menu.

The way data is displayed on the chart or recorded to disk/card is a function of three things: the input scale, the output scale and the chart scale. These may be programmed independently to provide a full scale output of any range of the input.

### 3.6.2 Input Scale

To set the **Input scale**:

1. From the **Point Setup** menu use the **UP (↑)** or **DOWN (↓)** button to highlight **Input scale** and then press the **ENTER** button.
2. You will be presented with a character keypad and asked for the value to represent the **low** or bottom end of the input scale and for this range; it will default to 0.0000. Up to thirteen characters can be entered. For our programming example, press the **ENTER** button to accept **0.0000** as the low end value.
3. You will then be asked for the value to represent the **high** end of the input scale. This value will default to 1.2500. For the sake of this exercise, use the character buttons to enter **1.0** and then press the **ENTER** button which will return you back to the **Point Setup** menu.

### 3.6.3 Output Scale

The Output scale is the value that will be reflected on the display or recorded to the units and will once again be scaled by using the Chart scale programmed at a later time.

To set the **Output scale**:

1. From the **Point Setup** menu use the **UP (↑)** or **DOWN (↓)** button to highlight **Output scale** and then press the **ENTER** button.
2. You will be asked to specify the number of decimal **places?** (0-5). For this example, use the **UP (↑)** or **DOWN (↓)** button to select **3** decimal places and then press the **ENTER** button.
3. You will be presented with the value for the **low** end of the output scale which defaults to 0. Press the **ENTER** button to accept **0**.
4. You will be presented with the **high** value which defaults to 1. Use the character buttons to enter **100.0** and then press the **ENTER** button which will return you back to the **Point Setup** menu.

You have now effectively programmed the Output scale to represent 100 times the Input scale.

### 3.6.4 Engineering Units

To set the **Engineering Units**:

1. From the **Point Setup** menu use the **UP (↑)** or **DOWN (↓)** button to highlight **Eng Units** and then press the **ENTER** button.
2. You may enter up to five characters representing the **Engineering units** using the alphanumeric keypad in the page mode as done for the **Point tag**. For this example, press the **PAGE** button until you see the percent sign (%) button.
3. Press the % button and then press the **ENTER** button which will return you back to the **Point Setup** menu.

You have now programmed the **Engineering units** to percent (%).

### 3.6.5 Chart Scale

To finalize the display scaling, we need to set the **Chart scale**. The actual Chart scale values are programmed elsewhere and are covered in section 3.7.

To set the **Chart scale**:

1. From the **Point Setup** menu use the **UP (↑)** or **DOWN (↓)** button to highlight **Chart scale** and then press the **ENTER** button.
2. You must choose one of eight scales (A-H). The default is **chart scl= A**. For the sake of this example, use the **UP (↑)** or **DOWN (↓)** button to specify **chart scl= B** and then press the **ENTER** button which will return you back to the **Point Setup** menu.

You have now successfully programmed a point. To save your programming, press the **EXIT** button. You will be asked if you want to **keep setup?**. Press the **ENTER** or **YES** button to save your programming. Then press the **EXIT** button twice to return to the default display.

## 3.7 Programming Point Scales

The next exercise is to program the **Chart scale** assigned to Point 1 in section 3.6.5.

To program the **Chart scale**:

1. From the **Command Button Bar** press the **PROG** button.
2. Use the **UP** (↑) or **DOWN** (↓) button to highlight **Chart/Pens** and then press the **ENTER** button.
3. Use the **UP** (↑) or **DOWN** (↓) button to highlight **Scales** and then press the **ENTER** button.
4. You will be asked which **scale?** to program. Two sets of eight scales are available: set '1' labeled A - H and set '2' labeled A - H. For this example, Use the **UP** (↑) or **DOWN** (↓) button to specify the scale **1B** then press the **ENTER** button. You are now presented with the **Scales** menu which enables you to program the scales. These options include: **Scale type**, **Scale ends**, **Scale grid**, and **Scale units**. The following sections cover some of these options. Refer to Section 5.5.2 for more detailed information.

### 3.7.1 Scale Type

The **Scale type** can be programmed linear (LIN) or logarithmic (LOG).

To set the **Scale type**:

1. From the **Scales** menu use the **UP** (↑) or **DOWN** (↓) button to highlight **Scale type** and press the **ENTER** button.
2. For this example, use the **UP** (↑) or **DOWN** (↓) button to highlight **type= LIN** to select linear and press the **ENTER** button.
3. Press the **EXIT** button to return back to the **Scales** menu.

### 3.7.2 Scale Ends

To set the **Scale ends**:

1. From the **Scales** menu use the **UP** (↑) or **DOWN** (↓) button to highlight **Scale ends** and press the **ENTER** button.
2. You be asked for the number decimal **places?** (0-5). For this example, use the **UP** (↑) or **DOWN** (↓) button to specify **2** and press the **ENTER** button.
3. You will be presented with a character keypad and asked for the **low** scale end value. Assume that you wish to present the percentage scale from 40 to 80 percent only across the screen effectively expanding the resolution that you can see. Use the character keypad buttons to enter a **low** value of **40** and then press the **ENTER** button.
4. You will then be asked for a **mid**-scale value. To keep things linear, use the character keypad buttons to enter a **midpoint** value of **60**, which is halfway between the 40 and 80 end points chosen to select, then press the **ENTER** button.
5. You will then be asked for the **high** end value. Use the character keypad buttons to enter **80** and then press the **ENTER** button to return back to the **Scales** menu.

### 3.7.3 Scale Units

The **Scale units** can be programmed in percent (%) to match the **Engineering units** programmed in Section 3.6.4.

To set the **Scale units**:

1. From the **Scales** menu use the **UP** (↑) or **DOWN** (↓) button to highlight **Scale units** and press the **ENTER** button.
2. The first page of a multi-page keypad will appear. Press the **PAGE** button until you see the percent sign (%) button.
3. Press the % button and then press the **ENTER** button to return to the **Scales** menu.
4. Press the **EXIT** button four times to return to the default display.

You have just programmed Point 1 to be a live input of 0 - 1 volts which will be scaled to an output of 0 - 100% and you have chosen to display between 40 and 80% full scale on the display, and this is what will be recorded to disk/ card. You can now program the other points in a similar fashion. It is suggested that you fully read the rest of the chapters of this manual to become familiar with the functions of the various menu options.

## 3.8 Recording Data

The Recorder saves data, on command, to either a 3½ inch floppy disk or CompactFlash™ card depending on which option is installed. The disks/cards are MSDOS™ compatible and can be read on any IBM PC compatible with a 3½ inch floppy drive or CompactFlash™ drive. Data is stored on the disks/cards as individual pen files with additional files for configuration and alarm/event logging. Any DOS or Windows File Manager can be used to move, rename, erase or archive the files. Recording may be started or stopped manually, by an external event or an internal alarm.

Each of the 15 points may be recorded at different sample rates, or the user can choose to record all points at the same rate. This enables slowly changing parameters to be recorded at a slower rate than faster changing signals. The user can also choose in which mode to store the data, including: Instantaneous, Average, Peak and Valley. The amount of data that can be saved depends on the number of channels and the sampling rate; both parameters can be set by the user. A 3½ inch 1.44 Megabyte floppy disk holds approximately 700,000 16-bit samples and a CompactFlash™ Card holds approximately 64,000,000 samples for a 128 Megabyte Card.

These numbers must be divided by the number of channels and the sampling rate to determine the total storage time for the disk/card. For example, using a 3½ inch 1.44 Megabyte floppy disk, recording four channels at 1 sample per second, the total recording time is: 700,000 divided by 4 (channels) multiplied by 1 (second) = 175,000 seconds or 48 hours. If the sampling rate were changed to 60 seconds, or 1 sample per channel every 1 minute, the recording time becomes 120 days.

The user can also store other types of data on the disk/card, including Configuration files that contain information about how the Recorder is set up and Alarm/Event log files that record all Alarm and/or Events to disk/card. Configuration files use the space of around 4,000 samples, while each Alarm or Event uses the space of 6 samples. The amount of data that can be stored on a disk/card is dependent on circumstances (how many alarms occur) and what has been selected for recording.

**NOTE:** Before a disk/card can be used for recording it must be **FORMATTED**. For best results, format the disk / card inside the Recorder.

### 3.8.1 Using the Recorder to format a floppy disk or CompactFlash™ card

To format a floppy disk or CompactFlash™ card using the Recorder:

1. Turn the unit on.
2. If you are using a floppy disk, ensure the disk is not write protected. The plastic slide in one corner of the floppy disk must be in a position such that it exposes the hole in the plastic cover.
3. Open the door below the LCD screen and insert the disk/card, label side up, into the drive.
4. From the **Main Button Bar** press the **MENU** button to bring up the **Command Menu Button Bar**.
5. Press the **PROG** button to bring up the Programming menu.
6. Use the **UP** (↑) or **DOWN** (↓) button to highlight **Record Setup** and then press the **ENTER** button.
7. Use the **UP** (↑) or **DOWN** (↓) button to highlight **Format Disk** and then press the **ENTER** button.
8. The display will read **format=NO\***. Press the **YES** button to change the display to read **format=YES?**.
9. Press the **ENTER** button to begin formatting. Once the disk/card is formatted, the unit will verify the disk/card. For large disks/cards this process may take a while. For disks/cards larger than 20 Meg, an **ABORT** button will be available in the lower right corner, and the process of verifying the disk/card can be aborted at any time. The light on the drive will come on until the format and verification is complete and then **Format Complete** will be displayed.
10. Press the **OK?** button to end the format. The disk/card is now formatted and ready for use.



### 3.8.2 Programming the unit for recording

There are a number of parameters that need to be set up before actual recording can take place. These are: which channels or points to record, at what rate to record them, and how to record them (Fill Mode and Data Mode). You must also arm the unit to record the actual data.

#### 3.8.2.1 Setting Which Points to Record

To set which points you wish to record:

1. From the Program menu, use the **UP** (↑) or **DOWN** (↓) button to highlight **Record Setup** and then press the **ENTER** button. This will bring up the Record Setup menu as shown in Figure 3-12.
2. From the **Record Setup** menu, use the **UP** (↑) or **DOWN** (↓) button to highlight **Points** and then press the **ENTER** button.
3. A window pops up and displays **point 1=no** or **point 1=yes**. To record this point press the **YES** button or to exclude this point press the **NO** button. You will automatically move to the next point. You can exit this menu at any time by pressing the **EXIT** button, or accept any entry by pressing then **ENTER** button.
4. There are fifteen possible points: 1-9 and A-F. For this example, set points 1,2,3 and 4 to **YES**.
5. Once you are done setting which points to record, press the **EXIT** button to return back to the **Record Setup** menu.

<b>Data on/off</b>
<b>Alarm on/off</b>
<b>Record Modes</b>
<b>Points</b>
<b>Points (Trigger)</b>
<b>Record rate</b>
<b>Disk Full Alarm</b>
<b>Format Disk</b>
<b>Save CFG File</b>
<b>Load CFG File</b>
<b>Filename</b>

Figure 3-12  
Record Setup Menu

#### 3.8.2.2 Setting the Record Rate

The **Record Rate** is the rate at which data is recorded to disk. It may be set independently for each channel or for all channels together. It may be set from a fastest time of eight times per second by setting the record rate to 0 seconds, or the slowest rate of once every 600 seconds (ten minutes).

To set the **Record Rate**:

1. From the **Record Setup** menu use the **UP** (↑) or **DOWN** (↓) button to highlight **Record Rate** and then press the **ENTER** button.
2. Use the **UP** (↑) or **DOWN** (↓) button to highlight **All Rates**, ignoring Individual Rate and Autorate for now, and then press the **ENTER** button. This will set the Record Rate for all channels simultaneously.
3. A numeric keypad will appear and the display will show **secs(lo)→1 ←** for **seconds low**. Use the numeric keypad to enter the Record Rate **5** (5 seconds between samples, 0=8 samples/sec) and press the **ENTER** button.
4. The display will then show **secs(hi)→0 ←**.for **seconds high**. Use the numeric keypad to enter the Record Rate **5** and press the **ENTER** button.
5. Press the **EXIT** button to return to the **Record Setup** menu.

**NOTE:** For this example, both the high and low Record Rates are set the same. The Record Rate can be changed by an external event if the Digital I/O option is fitted or by an alarm event.

#### 3.8.2.3 Setting the Fill Mode

There are basically two record **Fill Modes**: **Fill to End** or **Cycle Data** (Cyclic). The **Fill to End** mode records data on the disk/card until the disk/card is full and then the recording stops. The Disk Status area on the Status Bar of the display shows the percentage of disk/card space used. The **Cyclic** mode records data on the disk/card in blocks and once the disk/card becomes full, the first block of data recorded is overwritten by the most current block of data. A block contains approximately 500 samples, thus the 500 oldest samples are replaced with 500 newest samples. This continues to happen until the recording is stopped by the user. The Recorder recycles the space on the disk/card and can record indefinitely. The oldest data is always replaced with newest data and you will have a record of the most current data. The amount of data that will be on the disk/card is calculated as described earlier in Section 3.8.

To set the **Fill Mode**:

1. From the **Record Setup** menu use the **UP (↑)** or **DOWN (↓)** button to highlight **Record Modes** and then press the **ENTER** button.
2. Use the **UP (↑)** or **DOWN (↓)** button to highlight **Fill Mode** and press the **ENTER** button.
3. Use the **UP (↑)** or **DOWN (↓)** button to highlight **Fill to End** or **Cycle Data** and press the **ENTER** button.
4. Press the **EXIT** button twice to return to the **Record Setup** menu.

#### 3.8.2.4 Setting the Data Mode

There are four methods of storing data to the disk/card: **Instantaneous**, **Average**, **Peak** and **Valley**. The **Instantaneous** mode stores only the latest sample to the disk/card and is used if you have one of the special functions enabled, such as peak reading or moving average that does not need to be averaged. The **Average** mode will average all input data sampled at 8 times per second to the Record Rate being recorded. Thus, if data is being stored to disk/card once every minute (60 seconds), 480 samples will be averaged. The **Peak** mode will record the peak or maximum value within the selected Record Rate. The **Valley** mode will record the valley or minimum value within the selected Record Rate.

To set the **Data Mode**:

1. From the **Record Setup** menu use the **UP (↑)** or **DOWN (↓)** button to highlight **Record Modes** and then press the **ENTER** button.
2. Use the **UP (↑)** or **DOWN (↓)** button to highlight **Data Mode All** to set the record method for all channels at once (as opposed to **Data Mode Indiv.** which sets the record method for each channel individually) and then press the **ENTER** button.
3. Use the **UP (↑)** or **DOWN (↓)** button to highlight **Instantaneous**, **Average**, **Peak** or **Valley** and press the **ENTER** button.
4. Press the **EXIT** button twice to return to the **Record Setup** menu.

#### 3.8.2.5 Arming Record Data on/off

To **Arm the unit to record** the actual data:

1. From the **Record Setup** menu use the **UP (↑)** or **DOWN (↓)** button to highlight **Data on/off** and then press the **ENTER** button.
2. The current record status will be shown as **record data=YES\*** or **record data=NO?**. Press the **YES** button and then the **ENTER** button to activate recording of data. Selecting **record data=NO?** and press the **ENTER** button will inhibit data recording.

### 3.8.3 Starting Recording

To **start the unit to record** the actual data:

1. Press the **MENU** button or the **EXIT** button until you get to the **Command Menu Button Bar** (with DISP, PROG, FUNC and EXIT).
2. Press the **FUNCTION** button to bring up the **Function** menu.
3. Use the **UP (↑)** or **DOWN (↓)** button to highlight **Record On/Off** and then press the **ENTER** button.
4. You will have three choices: **Record Off** (to stop recording), **Record On** (to start recording) and **Trigger** (to enable automatic stop and start recording based on internal or external events that have been initiated). Ensure there is a formatted disk/card in the drive and then use the **UP (↑)** or **DOWN (↓)** button to highlight **Record On** and press the **ENTER** button.
5. A pop up window will appear asking **record on?**. Press the **YES** button and then the **ENTER** button to begin recording. Once a recording is started the drive light comes on periodically as data is stored to the disk/card. Also, the **Disk Status** area in the top right of the screen will indicate the percentage of the disk/card used.
6. Press the **EXIT** button three times to return to the default display.

**WARNING: Never remove a disk/card from the drive while the drive light is on.**



### 3.8.4 Stopping Recording

To **stop the unit from recording**:

1. Follow steps 1 through 3 from Section 3.8.3.
2. Use the **UP (↑)** or **DOWN (↓)** button to highlight **Record Off** and press the **ENTER** button.
3. A pop up window will appear asking **record off?**. Press the **YES** button and then the **ENTER** button to stop recording.
4. Wait for the disk light to go out and the **Disk Status** area to say **OFF x%** before removing the disk/card.
5. Press the **EXIT** button three times to return to the default display.

## 3.9 Hot-Swap

**Hot-Swap** is the ability to “Swap” disks/cards without turning off the record status so there is no data loss. As soon as a disk/card is removed a window will appear (see Figure 3-13) displaying the amount of time left before data is lost. For the fastest Record Rate of 8 times per second, you will have approximately 2.5 minutes (see chart below figure). Each pen has its own buffer so the approximate times listed are for any number of pens. The time in the window will count down in two second intervals for sample rates faster than 2 samples per second. The window will count down in intervals equivalent to the sample rate for rates faster than 2 samples per second. If there are different Record Rates, the buffer time displayed will be for the fastest Record Rate.

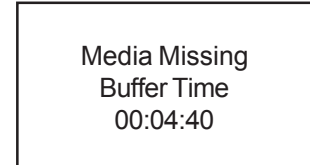

**Figure 3-13**  
**Buffer Time Window**

**WARNING:** Do not remove the disk/card while the green light is on.

To **Hot-Swap**:

1. Wait until the green light is not on and take the disk/card out of the drive.
2. When the disk/card is pulled out, the **Disk Status** area will indicate **NO MEDIA** and the **Media Missing Buffer Time** window will appear displaying the time left before data is lost.
3. Insert a new **formatted** disk/card into the drive, and the unit will continue recording.

Sample Rate	Buffer Time
8 Seconds/Sec	2.5 Min
1 Sample/Sec	20 Min
10 Sec/Sample	3 Hrs
1 Min/Sample	20 Hrs

**WARNING:** If the disk/card is not replaced within the time frame displayed, **data will be lost**.

## 3.10 Changing File Names

The user can name files to help identify the process being measured. The system uses a single filename for all types of files, pens, alarm, and configuration. The filename can be any DOS compatible name. Filenames can be changed as often as needed and multiple file sets can be recorded onto the same disk/card. Multiple configuration files may also reside on a single disk/card.

To change the **Filename**:

1. From the **Record Setup** menu use the **UP (↑)** or **DOWN (↓)** button to highlight **Filename** and press the **ENTER** button.
2. An alphanumeric keypad will appear and the current filename will be displayed. Use the alphanumeric keypad to enter up to eight characters for the new filename. Do not enter any file extension or “.”.
3. Once you have entered the filename you want, press the **ENTER** button.

## 3.11 Setting the Disk Full Alarm

It is possible to set a threshold to indicate when the disk is full. The indication is via a pop up window on the screen, or if the relay option is fitted, via a contact closure. The threshold limit may be set by the user to any value between 1 and 100 percent.

To set the **Disk Full Alarm** value:

1. From the **Record Setup** menu use the **UP (↑)** or **DOWN (↓)** button to highlight **Disk Full Alarm** and press the **ENTER** button.
2. There are three menu options: **Full setpoint**, **Full contact #** and **Rec. Contact #**. Use the **UP (↑)** or **DOWN (↓)** button to highlight **Full setpoint** and press the **ENTER** button.
3. An alphanumeric keypad will appear and you will be asked for the **setpoint?** at which the disk/card will indicate nearly full (0 to 100 percent, where 0 implies do not indicate disk full). Use the alphanumeric keypad to enter the **setpoint** percentage and then press the **ENTER** button.
4. If the relay option is fitted, use the **UP (↑)** or **DOWN (↓)** button to highlight **Full contact #** and press the **ENTER** button. A window will appear asking for the **Full contact #?**. Use the **UP (↑)** or **DOWN (↓)** button to choose a relay contact number (1 through 6, or 0 for no contact closure) and then press the **ENTER** button.
6. Press the **EXIT** button to return to the **Record Setup** menu.

A message will pop up on the display when the disk/card usage equals the percentage value entered above and the corresponding relay contact will close. Note that in all cases a message will pop up on the display and the relay contact will close when the disk/card is full.

## 3.12 Saving and Loading Configuration Files

Once all the points have been set up and all other data has been programmed, it is advisable to save the configuration to disk/card. Thus if the user needs to change any parameters for a different recording session, the prior settings can be recovered by loading a previously saved configuration file.

To **Save the Configuration**:

1. From the default display, press the **MENU** button to get the **Command Menu Button Bar**.
2. Press the **PROGRAM** button to get the Program menu.
3. Use the **UP (↑)** or **DOWN (↓)** button to highlight **Record Setup** and then press the **ENTER** button.
4. Use the **UP (↑)** or **DOWN (↓)** button to highlight **Save CFG File (Save ConFiGuration)** and press the **ENTER** button.
5. A pop up window will display **save config=NO\***. Press the **YES** button to change the message to **save config=YES?** and then press the **ENTER** button to save the configuration with the current filename to the disk. **SAVE CFG** will show in the **Disk Status** area and then a window will pop up indicating **Configuration Saved**.
6. Press the **OK?** button and then press the **EXIT** button three times to return to the default display.

**To Load an existing Configuration:**

1. From the default display, press the **MENU** button to get the **Command Menu Button Bar**.
2. Press the **PROGRAM** button to get the Program menu.
3. Use the **UP (↑)** or **DOWN (↓)** button to highlight **Record Setup** and then press the **ENTER** button.
4. Use the **UP (↑)** or **DOWN (↓)** button to highlight **Load CFG File (Load ConFiGuration)** and press the **ENTER** button.
5. A pop up window will display **load config=NO\***. Press the **YES** button to change the message to **load config=YES?** and then press the **ENTER** button. The unit will look on the disk/card for any configuration files and the File Directory will display any files found (see example below).

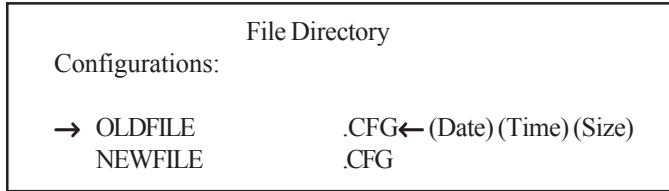

6. Use the **UP (↑)** or **DOWN (↓)** button to move the arrows next to the configuration file you want to load and then press the **ENTER** button. The unit will load the selected configuration file from the disk/card, and a window will pop up indicating **Configuration Loaded**.
7. Press the **OK?** button. The Recorder will then restart itself to recognize the new settings.

### 3.13 Browsing, Searching, Compressing and Expanding Data

If the **Graphics Area** is displaying the full screen Trend Chart or the full screen Alarm/Events Data Window, the **BROWS** button appears in the **Main Button Bar**. The **BROWS** button allows the user to browse, search or compress either data from the disk/card (including the file currently being recorded to disk/card) or immediate past data which is buffered to memory (RAM). The operation of browsing is the same whether the user is browsing memory or file data. When using the Trend Chart, browsing allows the user to view historic data of the pens currently trending on the display or saved on the disk/card, without affecting any real time data acquisition. Alarm data can also be browsed from memory when using the Alarm/Events Data Window.

When on the full screen Trend Chart, the **BROWS** button on the Main Button Bar brings up the **Browse Source Button Bar** with three buttons: FILE , RAM and EXIT, as shown in Figure 3-14 below.

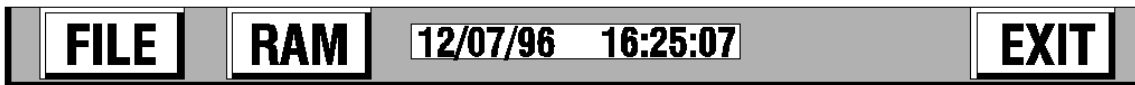

Figure 3-14 The Browse Source Button Bar

Press the **FILE** button to browse prerecorded files on the disk/card. Press the **RAM** button to browse Trend data from memory. Press the **EXIT** button to return to the real time view.

### 3.13.1 File Browsing

File browsing can be done at any time, even when still recording. However, if you are browsing from disk/card while recording, there may be delays in retrieving data from the disk/card as writing to the disk/card has priority over reading from the disk/card.

**To Browse a File:**

From the Browse Source Button Bar (Figure 3-14), press the **FILE** button. The unit will check the disk/card and then bring up the File Directory window (see below) allowing the user to choose which file to browse.

File Directory	
Point 1:	
→ BATCH1	.DT1 ← (Date) (Time) (Size)
BATCH2	.DT1
BATCH3	.DT1

The File Directory will list the file(s) for each Point, starting with Point 1. The filenames are specified by the user at the time of recording and have an extension of DTx where x is the Point number. The filename list will scroll if it is longer than what will fit on the screen. If no files are available for a particular point, the directory will indicate “No Files Found”.

**NOTE:** Ensure that a disk/card is present and that it has suitable files or you will get an error message.

Use the **UP** (↓) or **DOWN** (↑) button to move the arrows to the file you want to browse and then press the **ENTER** button. You will enter Browse Mode and the **Browse Mode Button Bar** will appear as shown in Figure 3-15 below.



Figure 3-15 The Browse Mode Button Bar

The **FINDV** button allows the user to **FIND** by **Value**, while the **FINDT** button allows the user to **FIND** by **Time**. The **BROWS** button enters the Interactive Browse feature (see Section 3.13.4). The “→←” and “←→” buttons are used to **COMPRESS** and **EXPAND** data respectively, and the **EXIT** button returns you back to the File Directory window.

### 3.13.2 Searching Data By Value

To Search the historic data by Value:

From the Browse Mode Button Bar, press the **FINDV** (FIND Value) button. This will bring up the **Search Value Button Bar** as shown in Figure 3-16 below.



Figure 3-16 The Search Value Button Bar

To set up the actual Value to search for, press the **VALUE** button. Use the numeric keypad to enter the Value to search for. You cannot search for an exact match; you will be looking for a Value immediately greater than or less than the Value you enter. Once you have entered the Value you want, press the **ENTER** button.

Before searching for the Value you set, you have to decide which **PEN** or point to use as the search reference and in which direction to search.

Use the **PEN** button to select the pen trace to search. Each time this button is pressed, the next pen is selected. The current pen is shown in the Status Line at the top of the screen, together with the value of the trace under the cursor and its actual time and date stamp.

The search direction is determined by the button to the left of the **PEN** button. This button toggles between **BACK** and **FRWD**. **BACK** will search BACKWARDS in time from the current cursor position (into older data), while **FRWD** will search FORWARDS in time from the current cursor position (into newer data).

To initiate a search press either the **FIND>** button to find the first point GREATER than the search value, or the **FIND<** button to find the first point LESS than the current search value. Each time either button is pressed, the next point that meets the search criteria is found. Once a point is found, the next point to be found will be the one that is after the first point that does not meet the criteria. The search “hops” across all other values so that you are not bogged down finding useless information. Therefore if you are searching for a point on a sine wave, for example, you will find the same point on the same phase of the wave (360° apart). Otherwise you would find every point less than or greater than the search point which could be every point in the trend.

The point that meets the search criteria will be placed under the cursor near the center of the screen. The search may take some time, especially if searching a large disk file. If no point is found, the unit will display “No Point Found”. The user can continue to search for other points in the same direction or change direction and search again. Once an acceptable point is found, the user can enter the Interactive Browse Mode by first pressing the **EXIT** button to return to the **Browse Mode Button Bar** and then pressing the **BROWS** button.

### 3.13.3 Searching Data By Time

To Search the historic data by Time:

From the Browse Mode Button Bar, press the **FINDT** (FIND Time) button. This will bring up a pop up window showing the Time to be searched. If the displayed Time is correct, press the **ENTER** button. Otherwise, press the **NO** button to bring up a series of windows enabling the desired Time to be entered. Press the **ENTER** button until the desired Time is displayed and then press the **ENTER** button again to display the Date. Press the **ENTER** button to accept the Date or the **NO** button to change the Date. A series of windows will be displayed to change the Date. Press the **ENTER** button until the desired Date is displayed and then press the **ENTER** button again to search the data. The sample corresponding to the desired Time and Date will be placed under the cursor near the center of the screen. The search may take some time, especially if searching a large disk file. If no point is found, the unit will display “No Point Found”. Once an acceptable point is found, the user can enter the Interactive Browse Mode by pressing the **BROWS** button.

### 3.13.4 Interactive Browse Mode

The Interactive Browse Mode enables the user to uniquely identify points on the screen by Time, Date and Value and move around in time. Once the browse source has been selected (from File or RAM), pressing the **BROWS** button again, immediately or after a search or compress operation, will enter the Interactive Browse Mode and the **Interactive Browse Button Bar** shown in Figure 3-17 below will appear.



Figure 3-17 The Interactive Browse Button Bar

The cursor appears near the center of the screen. It can be moved with the **UP** (↑) or **DOWN** (↓) button (shown above) in the Vertical mode, or with the **LEFT** (←) or **RIGHT** (→) button in the Horizontal mode. Pressing these buttons a single time moves the cursor one sample at a time, while holding these buttons will cause the cursor to move in 10 sample increments. As the cursor moves, the Time and Date information is updated in the Status Line at the top of the screen. To move about in larger increments, the **PAGE-** and **PAGE+** buttons move the data forward or backward an entire screen at a time.

When browsing graphics, the **Status Bar** at the top of the screen shows the Date and Time stamp and actual value for the trace data directly under the cursor. If you are browsing Memory, there will be an "M" in the right hand corner of this line. If browsing Files, there will be an "F" (see example below).

07/27/96 17:03:06 point 1: 0.318 Volts F
--

To see the actual pen data value press the **PEN** button to toggle the data through each trace if more than one trace is displayed. As the data is toggled, the traces for all pens but the selected one disappear.

Press the **EXIT** button to return to real time viewing from the RAM browser or to the File Directory from the FILE browser.

### 3.13.5 Compressing and Expanding Data

The data on the screen may be compressed up to 32 times the normal view which enables long term trends to be seen on a single screen. Each time the "→←" (Compress) button is pressed the data is compressed by a factor of 2. Allow a period of time for the Recorder to process the data. Pressing the "→←" (Compress) button five times will give the maximum of 32 times compression.

The user can enter the Interactive Browse Mode with any level of compression by simply pressing the **BROWS** button. The data may be expanded back by pressing the "←→" (Expand) button.

# Chapter 4 Operation

4.1 Instrument Power-up .....	4-1
4.1.1 Start-up Tests .....	4-1
4.1.1.1 Memory Test (RAM) .....	4-1
4.1.1.2 ROM Test .....	4-1
4.1.2 Load Database (user configuration) .....	4-1
4.1.3 Initialize Database .....	4-2
4.1.3.1 Smart Init .....	4-2
4.1.3.2 Full Init .....	4-2
4.1.3.3 Erase Config .....	4-2
4.1.3.4 Init Defaults .....	4-2
4.2 Menus .....	4-4
4.2.1 DISPL (Display) Menu .....	4-4
4.2.1.1 Point .....	4-4
4.2.1.2 Alarms .....	4-5
4.2.1.3 Junction Temp .....	4-5
4.2.1.4 Version .....	4-5
4.2.1.5 Media Status .....	4-5
4.2.2 PROG (Program) Menu .....	4-5
4.2.3 FUNC (Function) Menu .....	4-6
4.2.3.1 Record On/Off .....	4-6
4.2.3.2 Activate point .....	4-7
4.2.3.3 Bypass point .....	4-7
4.2.3.4 Reset point .....	4-7
4.2.3.5 Chart speed .....	4-7
4.2.3.6 Record speed .....	4-8
4.2.3.7 Alarm check .....	4-8
4.2.3.8 Scale set .....	4-8
4.2.3.9 Trnd message .....	4-8
4.2.4 Hidden Menu .....	4-9
4.2.4.1 Initialize .....	4-9
4.2.4.2 ADC Control .....	4-9
4.2.4.3 T/C comps cal. ....	4-9
4.2.4.4 Diagnostics .....	4-10
4.2.4.5 Clear buffers .....	4-10
4.2.4.6 Menu inact. T/O .....	4-11
4.2.4.7 File maintenance .....	4-11
4.2.4.8 Flush interval .....	4-11

## 4.1 Instrument Power-up

The Recorder executes multiple tests at initial start-up. These tests are referred to as Start-up Tests. While these tests are being performed, the recorder displays “Wait” on the status line. If the system fails any test, an error message will display and an error beep will sound. Be aware, however, that certain test failures are considered non-recoverable and will result in a complete shut-down of the system. These failures require immediate repair before the Recorder can continue to power-up.

### 4.1.1 Start-up Tests

The following paragraphs explain each test performed at initial start-up along with any possible error messages and recommended operator actions.

#### 4.1.1.1 Memory Test (RAM)

This routine tests all memory (RAM). If this test fails, the unit will halt, indicating the error, and must be repaired before further operation is allowed.

#### 4.1.1.2 ROM Test

A test is performed to verify the integrity of the system software by computing a 32-bit cyclic redundancy code (CRC) and comparing this code with a code stored in EPROM. If this test fails, the operator is given a choice to accept the fault and allow power-up to continue or not accept and power down the unit. If not accepted, the unit will halt and must be repaired. **The only time this fault should be accepted is after installing a software upgrade to the instrument.**

### 4.1.2 Load Database (user configuration)

The user configuration for the unit is stored in non-volatile battery backed memory. This memory consists of two main sections, Profile and Data Point Registers (DPR). The database is transferred from working memory areas to holding memory areas. The unit transfers this database back from the holding memory area to the working memory area during the power-up sequence. If no errors are detected, this transfer is practically instantaneous, no messages are displayed, and the recorder continues to power-up normally.

The unit's User Profile Database is grouped into blocks. Each block contains setup parameters related to a particular instrument function (i.e. display, chart, scan, etc.) and is protected by a checksum. The DPR database is also composed of discreet blocks, each block containing all the set-up information of a particular programmed Point. Each point DPR is protected by a checksum. During the automatic Learning operation, the Profile blocks and Point DPRs along with their checksums are transferred to the holding memory area.

*If the Recorder finds a bad checksum in any Profile block during the power-up load database sequence, it will halt.* The user is given a choice to ignore the problem or perform a Smart or Full Initialization. (See Section 4.1.3 Initialize Database.)

Answering NO to both “Smart” and “Full” initialization queries forces the Recorder to continue to power-up with corrupt parameters in the User Profile Database. This may be successful or the Recorder may “hang-up” or periodically reset.

Failures in the Profile Database should not occur. If this error occurs, a Smart initialization will have the least affect on the User Profile Database and allow completion of the power-up sequence.

If the Recorder finds a bad checksum in any Point DPR during the power-up load sequence, it will not issue any error message. Bad DPR's are flagged as “CORRUPT”. A corrupt DPR may only be corrected by reviewing the associated point.



### 4.1.3 Initialize Database

Three forms of initialization (init) may be performed on the Unit's Profile database: Smart Init, Full Init and Erase Configuration. The user will not typically see these options unless the unit is being powered up for the first time, or the unit finds an error in the database. These conditions may be manually invoked using the Hidden menu option.

#### 4.1.3.1 Smart Init

Smart Initialization verifies that each Profile database block has a correct checksum and (if incorrect) each parameter in the corrupt block(s) is verified to be within allowable boundaries. Only those parameters in corrupt blocks found to be outside these boundaries are changed. Bad parameters are always replaced with pre-defined defaults.

#### 4.1.3.2 Full Init

If the user answers no to "Smart init?", a choice is presented to force the Recorder to do a "Full init?". Full initialization will completely clear all user-defined parameters, setting them to pre-defined defaults.

#### 4.1.3.3 Erase Config

This option is used on first time power up and will not normally be seen by the user unless the database has been corrupted or this option is called from the SYSTEM menu. This option will clear all variables to zero, and should be used to clear memory before programming for the first time, or after upgrading the firmware. This operation is usually performed at the factory.

#### 4.1.3.4 Init Defaults

The listing below gives the default parameters that are used by both Smart and Full initialization:

##### Display Block

Power-up Display Mode =	Unit Tag
Display Rate =	1 second
Time Format =	American
Language =	English

##### Scan Block

Alarm Contact Outputs =	Open on Clear, No Reflash, Failsafe off, Open on ACK
Alarm Checks =	Enabled
TCBO Test Interval =	300 seconds (5 minutes)
Serial Port	
Serial Port =	Set to Modbus RTU, 9600, 8bits, parity off, 2 stop bits

##### Chart Scales Block

For Each Scale . . .

Scale Type =	Linear
Origin =	Left
Decimal Fix =	3 places
Scale =	Low = 0.0 Mid = 50.0 High = 100.0
Engineering Units =	Set to all spaces (cleared)
Active Scaleset =	Set to scaleset 1

## Chapter 4 Operation

Bargraph/Pens Block	
Pen Assignments =	Set to Pen 1 = point 1, Pen 2 = point 2, Pen 3 = point 3, Pen 4 = point 4, Pen 5 = point 5, Pen 6 = point 6, Pen 7 = point 7, Pen 8 = point 8, Pen 9 = point 9, Pen A = point A, Pen B = point B, Pen C = point C
Bar Assignments =	Set to Bar 1 = point 1, Bar 2 = point 2, Bar 3 = point 3, Bar 4 = point 4, Bar 5 = point 5, Bar 6 = point 6, Bar 7 = point 7, Bar 8 = point 8, Bar 9 = point 9, Bar A = point A, Bar B = point B, Bar C = point C
Digital Assignments =	Set to Digital 1 = point 1, Digital 2 = point 2, Digital 3 = point 3, Digital 4 = point 4, Digital 5 = point 5, Digital 6 = point 6, Digital 7 = point 7, Digital 8 = point 8, Digital 9 = point 9, Digital A = point A, Digital B = point B, Digital C = point C
Display Chart Speed Block	
Unit Tag =	Set to "Unit Tag"
Chart Speed =	Standard. High Speed, No AutoSpeed change on alarm
Lo Chart Speed =	60"/hr
Hi Chart Speed =	60"/hr
Passcode Protection Block	
Program Key Passcode =	Set to None
Function Key Passcode =	Set to None
Digital Inputs (External Switches)	
All 3 inputs =	Set to Events mode
All Event Messages =	Set to spaces (cleared)
Recorder	
Record =	Off
Record Speed =	8 samples/second
Record Mode =	Fill to End
Pens =	None
Record Data, Alarms =	Off
File Name	
Filename =	SWRevNo (Software Revision Number)

## 4.2 Menus

Additional menus are available for changing the Display, Programming the unit and setting Functions. When the **MENU** Button (located at the right of the Main button bar at the bottom of the display) is pressed, the **Command Menu Button Bar** appears as shown in Figure 4-1. The **Command Menu Button Bar** has entry points to the **DISPL**ay, **PROG**ram, and **FUN**Ction menus. Both the **PROG**ram menu and the **FUN**Ction menu can be password protected, each with its own password (Refer to Section 5.11.2). The **PROG**ram menu is covered fully in Chapter 5, "Programming".



Figure 4-1 The Command Menu Button Bar

### 4.2.1 DISPL (Display) Menu

The **DISPL**ay Menu allows the user to program what information is displayed transiently in the STATUS line along the top of the display screen (See Fig 1-1 for location of the Status Line). This display can be used to show point data, alarm information, junction temperature, the firmware version and media status. Note that the default display is the Unit tag, which is programmed in the **PROG**ram, **Displays**, **Powerup disp**, **Unit tag** menu option (see Section 5.4.3).

When the **DISPL**ay Button is pressed, the Display menu is displayed as shown in Figure 4-2.

#### 4.2.1.1 Point

To display a Point value on the Status Line:

From the Display menu use the **UP** (↑) or **DOWN** (↓) button to highlight **Point** and then press the **ENTER** button. You will be prompted with "point? X". Use the numeric keypad to select the point number you wish to display and press the **ENTER** button. Listed below are parameters or responses that may be displayed:

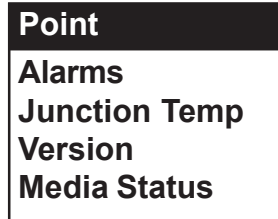

Figure 4-2 Display Menu

Point No.	Value	Eng Units
1	0.496	VOLTS

Point No.	Status / Message
1	BYPASS

Point number requested has been set to be bypassed.

1	TCBO
---	------

Thermocouple Burnout

1	INVALID
---	---------

ADC is overrange for direct inputs

1	OVRNG
---	-------

Point measurement exceeds the limit of the table.

1	OVRFLW
---	--------

Data of calculated points exceeds the limit of the floating point math function.

**NOTE:** To have the point information come up automatically at power up and be the default display, use the **PROG**ram, **Displays**, **Powerup disp** option to set **Point** as the **Powerup display** default. You can also set the **Powerup display** default to **Autojog** which will cycle through all points. Refer to Section 5.4.3.

### 4.2.1.2 Alarms

To display an Alarm status:

From the Display menu use the **UP** (↑) or **DOWN** (↓) button to highlight **Alarms** and press the **ENTER** button. The display will show the status of the alarms. If no alarms are present, the display will show "NO ALARMS". If more than one alarm is active, the display will cycle through all active alarms. If the Alarm check option is turned off, this will be indicated on the display as "ALM CHKS OFF".

**NOTE:** To have the Alarm information come up automatically at power up and be the default display, use the PROGram, Displays, Powerup disp option to set **Alarms** as the Powerup display default. Refer to Section 5.4.3.

### 4.2.1.3 Junction Temp

To display Cold Reference Junction Temperature:

From the Display menu use the **UP** (↑) or **DOWN** (↓) button to highlight **Junction Temp** and press the **ENTER** button. The display will show the cold reference junction temperature in degrees Fahrenheit (°F) (degrees Celsius [°C] if the time format is set to European).

**NOTE:** To have the Junction Temperature information come up automatically at power up and be the default display, use the PROGram, Displays, Powerup disp option to set **Junction Temp** as the Powerup display default. Refer to Section 5.4.3.

### 4.2.1.4 Version

This option displays the software version number in a pop-up window.

To display the version of software in your unit:

From the Display menu use the **UP** (↑) or **DOWN** (↓) button to highlight **Version** and press the **ENTER** button. The version of software in your unit will be displayed. Press the **OK?** button to return to the Display menu.

### 4.2.1.5 Media Status

This option displays the status of a disk/card in the Media Status Window as shown in Figure 4-3.

To display the Media Status Window:

From the Display menu use the **UP** (↑) or **DOWN** (↓) button to highlight **Media Status** and press the **ENTER** button. A window will be displayed (similar to Figure 4-3) showing the total size of the disk, the amount of free space available on the disk, the write protected status, the status of the format, battery information and memory.

Total Size:	1,423 K
Free:	1,141 K
Write Prot:	NO
Format:	OK
Battery:	N/A
Memory:	1,024K

**Figure 4-3**  
**Media Status Window**

To remove the Media Status Window:

From the Display menu use the **UP** (↑) or **DOWN** (↓) button to highlight **Media Status** and then press the **ENTER** button and the window will clear.

## 4.2.2 PROG (Program) Menu

The Program Menu allows the user to program inputs and associated parameters into the Recorder. Refer to Chapter 5 of this Manual for complete programming details.

### 4.2.3 FUNC (Function) Menu

The **FUNCTION** Menu allows the user to program the unit for numerous functions. The **FUNCTION** menu may be password protected in which case you will be required to enter the password before proceeding. Refer to Section 5.11.2.

When the **FUNCTION** Button is pressed, the Function menu is displayed as shown in Figure 4-4.

#### Record On/Off

Activate pt  
Bypass pt  
Reset pt  
Chart speed  
Record speed  
Alarm check  
Scale set  
Trnd message

#### 4.2.3.1 Record On/Off

The Record On/Off option allows the user to stop or start recording to disk/card.

To set the Record On/Off:

From the Function menu use the **UP** (↑) or **DOWN** (↓) button to highlight **Record On/Off** and then press the **ENTER** button. The Record On/Off menu will be displayed with three options: **Record Off**, **Record On** and **Trigger**. These options are described in the following sections.

Figure 4-4  
Function Menu

##### 4.2.3.1.1 Record Off

The Record Off function enables the user to stop the recording to disk/card irrespective of the state of any record triggers.

To stop a current record session:

Use the **UP** (↑) or **DOWN** (↓) button to highlight **Record Off** and then press the **ENTER** button. A pop up window will ask to confirm the selection **record off?**. Press the **YES** button to proceed or the **NO** button to exit. Press the **EXIT** button to return to the Function menu.

##### 4.2.3.1.2 Record On

Before recording data, the user must set up the record information as detailed in Chapter 5, Section 5.7 Record Setup. Parameters which need to be set include filename; whether to record data, alarms or both; the record speed; which channels to record and the record mode. Refer to Chapter 3 for quick setup information.

The Record On function will start recording to disk irrespective of the state of the record triggers provided the Record Setup has been done correctly.

To begin recording:

Make sure that there is a disk/card in the drive. Use the **UP** (↑) or **DOWN** (↓) button to highlight **Record On** and then press the **ENTER** button. A pop up window will ask to confirm the selection **record on?**. Press the **YES** button to proceed or the **NO** button to exit. Press the **EXIT** button to return to the Function menu.

##### 4.2.3.1.3 Trigger

Selecting the Trigger option will enable the unit to record from an external event or internal alarm. Internal record on alarm triggers are set in the Record Setup menu (section 5.7.5) while external event triggers are set in the Digital Input/Output Setup menu (section 5.9.2). If the Recorder is set in the record Trigger mode, either of these event triggers will control the Record On or Record Off function depending on whether the events are active or inactive.

To set the Recorder to record from an external event or internal alarm:

Make sure that there is a disk/card in the drive. Use the **UP** (↑) or **DOWN** (↓) button to highlight **Trigger** and then press the **ENTER** button. A pop up window will ask to confirm the selection **trigger on?**. Press the **YES** button to proceed or the **NO** button to exit. Press the **EXIT** button to return to the Function menu.

The current record status is shown in the Disk Status section in the top left corner of the screen. If the unit is not recording, **OFF X%** will be displayed where X is the percentage of the disk/card used. If the unit is recording data, **RECORD X%** will be displayed if the unit is set to record manually or **TRIG'D X%** will be displayed if the unit is triggered to record from an internal alarm or external event. Any disk error will be shown in a pop-up window.

#### 4.2.3.2 Activate point

This menu item returns temporarily bypassed points to the measurement cycle for measuring inputs and displaying information.

To Activate a point or points:

From the Function menu use the **UP (↑)** or **DOWN (↓)** button to highlight **Activate pt** and then press the **ENTER** button. Use the numeric keypad to enter the point number to activate and press the **ENTER** button. The next point is then displayed. Continue to enter the point numbers to activate and then when point activation is finished, press the **EXIT** button to return to the Function menu.

#### 4.2.3.3 Bypass point

This menu item removes active points from the measurement cycle. A bypassed point will still be in the database and the message "BYPASSED" will be displayed when the bypassed point appears on the display or is printed.

To Bypass a point or points:

From the Function menu use the **UP (↑)** or **DOWN (↓)** button to highlight **Bypass pt** and then press the **ENTER** button. Use the numeric keypad to enter the point to bypass and press the **ENTER** button. The next point is then displayed. Continue to enter the point numbers to bypass and then when finished, press the **EXIT** button to return to the Function menu.

#### 4.2.3.4 Reset Point

This function allows certain point values to be reset without reprogramming each parameter. The value of the following types of calculated points may be reset:

Moving average	Resets data to the current value of the Basepoint
High peak	Resets data to the current value of the Basepoint
Low peak	Resets data to the current value of the Basepoint
Totalize	Resets to zero

Only the above listed point types will be prompted in this menu item.

To Reset a point or points:

From the Function menu use the **UP (↑)** or **DOWN (↓)** button to highlight **Reset pt** and then press the **ENTER** button. Use the numeric keypad to enter the point to reset and press the **ENTER** button. The next point is then displayed. Continue to enter the point numbers to reset and then when finished, press the **EXIT** button to return to the Function menu.

#### 4.2.3.5 Chart speed

This menu option selects between the Low or High Chart speed. The actual Chart speed is selected in the PROGram, Chart/Pens, Speed menu option (see section 5.5.1). The default setting for both the Low and High Chart speed settings is 60 inches per hour.

To select the Chart speed:

From the Function menu use the **UP (↑)** or **DOWN (↓)** button to highlight **Chart speed** and then press the **ENTER** button. Use the **UP (↑)** or **DOWN (↓)** button to highlight **speed= LO** or **speed= HI** and then press the **ENTER** button. Press the **EXIT** button to return to the Function menu.

#### 4.2.3.6 Record speed

The Record speed is the rate at which data is stored to disk/card irrespective to the rate at which it is displayed on the chart. There are two Record speeds for each channel or point: Low or High. The actual Low and High Record speed values are set in the PROGram, Record Setup, Record Rate menu option (Section 5.7.6). These rates can also be changed via an external event (Section 5.9.2.6).

To change the Record speed:

From the Function menu use the **UP (↑)** or **DOWN (↓)** button to highlight **Record speed** and then press the **ENTER** button. Use the **UP (↑)** or **DOWN (↓)** button to highlight **speed= LO** or **speed= HI** and then press the **ENTER** button. Press the **EXIT** button to return to the Function menu.

#### 4.2.3.7 Alarm check

The Alarm check function controls whether or not the unit checks for Alarms. When checking for Alarms, the unit will compare a point's value to the programmed low or high Alarm setpoint values (see Section 5.6.5.10). The Alarm/Event Data Window shows the current Alarm check status. If the Alarm checking is set to **YES**, the **ACK**nowledgment button will flash in the upper left corner until the user acknowledges the Alarm. **Alarms will not be checked unless the Alarm Check option is set to YES.**

To change the Alarm check status:

From the Function menu use the **UP (↑)** or **DOWN (↓)** button to highlight **Alarm check** and then press the **ENTER** button. The current Alarm status will be displayed as either **almchk=YES\*** or **almchk=NO\***. Press the **YES** or **NO** button to change the status to the desired option and then press the **ENTER** button to return to the Function menu.

#### 4.2.3.8 Scale set

Two sets of 8 scales (A-H) can be programmed (see Section 5.5.2), but only one of the two sets can be active at any given time. The Scale set menu option is used to select the active Scale set as 1 or 2.

To select a Scale set:

From the Function menu use the **UP (↑)** or **DOWN (↓)** button to highlight **Scale set** and then press the **ENTER** button. Use the **UP (↑)** or **DOWN (↓)** button to highlight **scaleset= 1** or **scaleset= 2** and then press the **ENTER** button. Press the **EXIT** button to return to the Function menu.

#### 4.2.3.9 Trnd message

This menu option is used to manually print one of the six pre-programmed Event messages (see Section 5.9.3) to the Alarm/Events Window and Alarm file.

To select an Event Message:

From the Function menu use the **UP (↑)** or **DOWN (↓)** button to highlight **Trnd message** and then press the **ENTER** button. Use the **UP (↑)** or **DOWN (↓)** button to display the desired Event message and then press the **ENTER** button to return to the Function menu.

## 4.2.4 Hidden Menu

The Recorder has a Hidden menu that allows the user to Initialize data, calibrate the Analog-to-Digital Converter (ADC Control), adjust the Ambient Temperature sensor reading (T/C comps cal.), perform various Diagnostics, Clear buffers, set the menu inactivity timeout (Menu inact. T/O), perform File maintenance, and set the Flush interval.

To access the Hidden menu:

Press the **MENU** button and then immediately press the **upper right-hand corner** of the display. The Hidden menu will be displayed as shown in Figure 4-5.

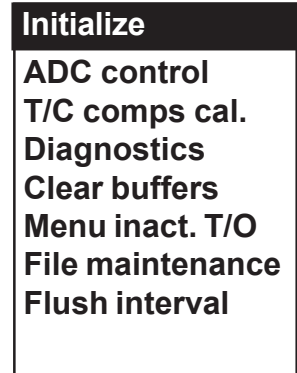

**Figure 4-5**  
Hidden Menu

### 4.2.4.1 Initialize

**CAUTION: Use of these menu items will adversely affect the system configuration. Refer to Section 4.1.3 for an explanation of the Initialize menu options.**

To Initialize the unit:

From the Hidden menu use the **UP (↑)** or **DOWN (↓)** button to highlight **Initialize** and then press the **ENTER** button. There are three choices:

- Init Profile**            Perform a Smart or Full Initialization. Refer to Section 4.1.3 for detail.
- Clear Points**        Restore all points to the unprogrammed state. This will clear any invalid setup data. Note that any cleared point can be restored in the Point setup menu.
- Erase Config**        Set all data to zero, clear all memory. **USE WITH CAUTION!** Will cause the unit to RESET.

Use the **UP (↑)** or **DOWN (↓)** button to highlight the desired option and then press the **ENTER** button. Proceed with caution - Press the **YES** and/or **ENTER** button to perform the desired function. Press the **NO** or **EXIT** button to return to the three Initialize options. Press the **EXIT** button to return to the Hidden menu.

### 4.2.4.2 ADC Control

This menu option allows the user to calibrate the Analog-to-Digital Converter through the use of submenu options. If the ADC is not calibrated properly, the value of the inputs may not be correct.

Refer to Chapter 6 of this Manual for complete Calibration details.

**CAUTION: DO NOT ATTEMPT TO CALIBRATE THE RECORDER UNLESS YOU HAVE THE CORRECT EQUIPMENT AVAILABLE.**

### 4.2.4.3 T/C comps cal.

This menu option allows the user to adjust the Ambient Temperature sensor reading for varying conditions. The value is set in 10ths of a degree (i.e. -15 is equivalent to -1.5 °C).

To change the temperature value:

From the Hidden menu use the **UP (↑)** or **DOWN (↓)** button to highlight **T/C comps cal.** and then press the **ENTER** button. You will be prompted with "10ths deg C → -15 ←". Change the value using the numeric keypad and then press the **ENTER** button to return to the Hidden menu.



#### 4.2.4.4 Diagnostics

The Diagnostics menu option allows the user to perform diagnostics checks on parts of the Recorder and media. **This menu option is for use by qualified service technicians only.** If additional diagnostics are needed, please contact the factory.

To perform diagnostics:

From the Hidden menu use the **UP (↑)** or **DOWN (↓)** button to highlight **Diagnostics** and then press the **ENTER** button. Use the **UP (↑)** or **DOWN (↓)** button to highlight one of the following: **Ram Test, Ram Test Full, Rom Test, Keyboard Test** and **Display Test** and press the **ENTER** button.

##### 4.2.4.4.1 Ram Test

This test verifies the integrity of the most oftenly used Random Access Memory or working storage based on a predetermined pattern. Follow the on-screen instructions to run the test. This test is also done when the Recorder is powered on.

##### 4.2.4.4.2 Ram Test Full

This test verifies the integrity of the complete Random Access Memory or working storage based on a predetermined pattern. Follow the on-screen instructions to run the test. **NOTE: This is a destructive test. Save your configuration to disk/card before running this test.**

##### 4.2.4.4.3 Rom Test

This test verifies the integrity on the system software by computing a 32-bit cyclic redundancy code (CRC) and comparing this code with a code stored in EPROM. A window showing "Test Passed" will be displayed when the test has passed. Press the **OK?** button.

##### 4.2.4.4.4 Serial Test

This test verifies the RS232 port is working properly. **NOTE: A loop back test connector is needed to perform this test.** Follow the on-screen instructions to run the test.

##### 4.2.4.4.5 Keyboard Test

This test verifies that all touchscreen keys are working properly. The left half of the screen will display 15 buttons with "?" on them. Press each button to make them disappear. Once the left side buttons are cleared away, 15 more buttons will appear on the right side of the display. A window showing "Test Passed" will be displayed when all of the buttons are cleared. Press the **OK?** button.

##### 4.2.4.4.6 Display Test

This test verifies that all the pixels on the display are working. Continue to touch the display anywhere to go through a block pattern which will turn on all pixels.

When all diagnostics have been performed, press the **EXIT** button to return to the Hidden menu.

#### 4.2.4.5 Clear buffers

The Clear buffers option allows the user to erase the Alarms and File data.

To Clear the buffers:

From the Hidden menu use the **UP (↑)** or **DOWN (↓)** button to highlight **Clear buffers** and then press the **ENTER** button. Once the buffers are erased, data will begin collecting for future browsing.

#### 4.2.4.6 Menu inact. T/O

The Menu inactivity timeout sets the amount of time before any menus are collapsed and the default graphic screen is displayed. Values are 1 (default) to 255 minutes. A value of zero (0) will disable this feature.

To change the timeout value:

From the Hidden menu use the **UP (↑)** or **DOWN (↓)** button to highlight **Menu inact. T/O** and then press the **ENTER** button. Use the numeric keypad to change the value and then press the **ENTER** button.

#### 4.2.4.7 File maintenance

This option allows the user to erase or write-protect files.

To perform File maintenance:

From the Hidden menu use the **UP (↑)** or **DOWN (↓)** button to highlight **File maintenance** and then press the **ENTER** button. Use the **UP (↑)** or **DOWN (↓)** button to select a file from the File Directory and then press the **ERASE** button to erase the file or the **PROT** button to write-protect the file. An asterisk (\*) after the file size indicates that a file is write-protected. Press the **EXIT** button to return to the Hidden menu.

#### 4.2.4.8 Flush interval

This option sets the amount of time between flushes to disk. Values are 1 to 255 minutes. Default is 15 minutes. The higher the value, the less wear there will be on the media; however, there is an exposure in that a power failure may cause the loss of data in the buffer since the last flush to media.

To change the Flush interval value:

From the Hidden menu use the **UP (↑)** or **DOWN (↓)** button to highlight **Flush interval** and then press the **ENTER** button. Use the numeric keypad to change the value and then press the **ENTER** button.

# Chapter 5 Programming

5.1 Introduction .....	5-1
5.1.1 Arrow and ENTER Buttons .....	5-1
5.1.2 EXIT Button Uses .....	5-1
5.2 Program Menu .....	5-1
5.2.1 Invoking the Program Menu .....	5-1
5.2.2 Passcode Protection .....	5-2
5.2.3 Program Menu Selections .....	5-2
5.3 Time and Date .....	5-2
5.3.1 Time .....	5-2
5.3.2 Date .....	5-2
5.4 Displays .....	5-3
5.4.1 Display rate .....	5-3
5.4.2 Time format .....	5-3
5.4.3 Powerup display (Powerup disp) .....	5-3
5.4.3.1 Unit tag .....	5-4
5.4.3.2 Auto jog .....	5-4
5.4.3.3 Point .....	5-4
5.4.3.4 Alarms .....	5-4
5.4.3.5 Junction Temp .....	5-4
5.4.4 Bar assign .....	5-5
5.4.5 Digital assign .....	5-5
5.4.6 Display Colors (Color Units ONLY) .....	5-5
5.4.7 Pick Views .....	5-5
5.4.8 Rotate Scales .....	5-6
5.4.9 Screen Dimmer .....	5-6
5.5 Chart/Pens .....	5-6
5.5.1 Speed .....	5-6
5.5.1.1 Set speeds .....	5-7
5.5.1.2 Autospeed .....	5-7
5.5.2 Scales .....	5-7
5.5.2.1 Scale type .....	5-7
5.5.2.2 Scale ends .....	5-7
5.5.2.3 Scale grid .....	5-8
5.5.2.4 Scale units .....	5-8
5.5.3 Pens .....	5-9
5.5.3.1 Pens assign .....	5-9
5.5.3.2 Abnorm. Pen .....	5-9
5.5.3.3 Trace Width .....	5-9
5.5.4 Direction .....	5-9
5.6 Points .....	5-10
5.6.1 Constants .....	5-10
5.6.2 Programming Points .....	5-10
5.6.3 Point Programming Options .....	5-10
5.6.3.1 Setup an Unprogrammed Point (Setup pt) .....	5-10
5.6.3.1 Setup a Point by Copying (Copy pt) .....	5-11
5.6.3.2 Setup a Point by Restoring (Restore pt) .....	5-11

5.6.3.3	Modify an Existing Point (Modify pt)	5-11
5.6.3.4	Delete an Existing Point (Delete pt)	5-11
5.6.4	Programming Point Types	5-11
5.6.5	Programming Parameters	5-11
5.6.5.1	Point tag	5-11
5.6.5.2	Input scale	5-12
5.6.5.3	Output scale	5-12
5.6.5.4	Exc. Currents	5-12
5.6.5.5	Decimal fix	5-13
5.6.5.6	Filter	5-13
5.6.5.7	Compensation	5-13
5.6.5.8	Span/offset	5-14
5.6.5.9	Engineering (Eng) units	5-14
5.6.5.10	Alarms	5-14
5.6.5.11	Chart scale	5-17
5.6.5.12	Output mode	5-18
5.6.5.13	Set equation	5-19
5.6.5.14	Basepoint	5-19
5.6.5.15	Reset control	5-19
5.6.5.16	Time period	5-22
5.6.5.17	Gate control	5-22
5.6.5.18	Flowrate	5-22
5.6.5.19	Low cutoff	5-23
5.6.5.20	Set cndtionl	5-23
5.6.5.21	Timeout	5-23
5.6.6	Linear Current/Voltage Point Types	5-24
5.6.7	Dry Contact Point Type	5-24
5.6.8	Industrial Square Root Current/Voltage Point Types	5-25
5.6.9	Logarithmic Linear Point Types	5-25
5.6.10	Thermocouple (T/C) Point Types	5-26
5.6.11	Resistance Temperature Detector (RTD) Point Types	5-26
5.6.12	Calculated Point Types	5-26
5.6.12.1	Equation	5-27
5.6.12.2	High (Hi) Peak	5-27
5.6.12.3	Low (Lo) Peak	5-28
5.6.12.4	High/Low Difference (Hilo diff)	5-28
5.6.12.5	Moving average (avg)	5-28
5.6.12.6	Time average (avg)	5-29
5.6.12.7	Gated timer	5-29
5.6.12.8	Totalize	5-29
5.6.13	Conditional Point Types	5-30
5.6.14	External Point Types	5-30
5.7	Record Setup	5-31
5.7.1	Data on/off	5-31
5.7.2	Alarm on/off	5-32
5.7.3	Record Modes	5-32
5.7.3.1	Fill Mode	5-32
5.7.3.2	Data Mode All	5-33
5.7.3.3	Data Mode Individ.	5-33
5.7.4	Points	5-33
5.7.5	Points (Trigger)	5-34
5.7.6	Record Rate	5-34
5.7.6.1	All Rates	5-34
5.7.6.2	Individual Rates	5-35
5.7.6.3	Autorate	5-35

5.7.7 Disk Full Alarm .....	5-35
5.7.7.1 Disk Full Setpoint (Full setpoint) .....	5-35
5.7.7.2 Disk Full Alarm Output (Full contact #) .....	5-36
5.7.7.3 Record Mode Alarm Output (Rec. contact #) .....	5-36
5.7.8 Format Disk .....	5-36
5.7.9 Save Configuration (CFG) File .....	5-36
5.7.10 Load Configuration (CFG) File .....	5-37
5.7.11 Filename .....	5-37
5.8 Measurement .....	5-38
5.8.1 Span & Offset .....	5-38
5.8.2 Demo Mode .....	5-38
5.9 Digital I/O .....	5-39
5.9.1 Contact outs .....	5-39
5.9.1.1 Alarms clear .....	5-39
5.9.1.2 ACK key .....	5-39
5.9.1.3 Failsafe .....	5-39
5.9.1.4 Reflash .....	5-40
5.9.2 Switches in .....	5-40
5.9.2.1 Event .....	5-40
5.9.2.2 Chart speed .....	5-40
5.9.2.3 Record on/off .....	5-41
5.9.2.4 Alarm Acknowledge (ack) .....	5-41
5.9.2.5 Scale set .....	5-41
5.9.2.6 Record Rate .....	5-41
5.9.3 Event messages .....	5-41
5.10 Com Ports .....	5-42
5.10.1 Com Port .....	5-42
5.10.1.1 Protocol .....	5-42
5.10.1.2 Port setup .....	5-43
5.10.1.3 Network ID .....	5-44
5.10.1.4 Modem Setup .....	5-44
5.10.1.5 Ethernet .....	5-44
5.10.2 Network ID .....	5-45
5.10.3 Modem Setup .....	5-46
5.10.3.1 Modem Enable .....	5-46
5.10.3.2 Modem String .....	5-46
5.11 System .....	5-47
5.11.1 Beeper .....	5-47
5.11.2 Passcodes .....	5-47
5.11.3 Alternate (Alt.) Language .....	5-48
5.11.3.1 Select Language (Lang.) .....	5-48
5.11.3.2 Load Alternate Language (Alt. Lang.) .....	5-48
5.11.3.3 Save English .....	5-49
5.11.3.4 Save Alternate Language (Alt. Lang.) .....	5-49
5.11.4 Printer out .....	5-49
5.11.4.1 Data .....	5-49
5.11.4.2 Events .....	5-49
5.11.4.3 Data Interval .....	5-50
5.11.4.4 Characters/Line .....	5-50
5.11.4.5 Data Lines .....	5-50

## 5.1 Introduction

This chapter provides information for programming the Recorder. Custom programming is required to define functions and allows you to personalize features for performing specific applications and tasks. Programming is simplified with menu-driven prompts which minimize the amount of time required for programming. The programmed information is stored in nonvolatile memory until modified by the user. The user has to program the points or data channels for scaling, displaying and logging or recording. Other options allow the user to program the display, alarms and event monitoring as well as overall unit operation.

**NOTE:** Programming will be easier with a full understanding of the programming structure. For this reason, it is recommended that you read this entire chapter before attempting to program your Recorder.

### 5.1.1 Arrow and ENTER Buttons

Use the UP (↑) and DOWN (↓) buttons to scroll through the PROGram Menu. A variety of selectable menu items and applications are available. When the function to be programmed is displayed in inverse video (highlighted), press the **ENTER** button and follow the prompts. The system prompts you for various parameters as you go through the programming task. On some menu items the LEFT (←) and RIGHT (→) buttons allow you to move within the current entry parameter to edit a single character.

**NOTE:** If the cursor is against the left end of the data string (first character) and the LEFT (←) Arrow Key is pressed three times, the entire data string will be erased.

### 5.1.2 EXIT Button Uses

To exit the PROGram Menu or any sub menu, press the **EXIT** button once to return to the previous menu prompt, twice to return to the menu prompt before the last one and so on until the Main Button Bar is displayed.

**NOTE:** If you exit a programming sequence early, the system will not register any programming values previously done within that sequence. As you leave a menu, if any changes are made in that menu, the Recorder will prompt "Keep Setup?". Simply answer YES to save the changed parameters or NO to exit the menu and not save the changed parameters.

## 5.2 Program Menu

The **PRO**Gram Menu allows the user to program point inputs and operating parameters for a variety of selectable functions and applications. The **PRO**Gram menu may be password protected in which case you will be required to enter the password before proceeding. Within the **PRO**Gram menu use the **UP** (↑) or **DOWN** (↓) button to display the desired programming function in inverse video (highlighted), press the **ENTER** button and follow any prompts. The system prompts you for various parameters as you go through the programming task.

### 5.2.1 Invoking the Program Menu

To enter the **PRO**Gram Menu:

Press the **MENU** button to the far right of the Main Button Bar at the bottom of the screen. This will bring up the **Command Button Bar** as shown in Figure 5-1 below.



Figure 5-1 The Command Button Bar

Press the **PROG** (for PROGram) button to bring up the **PRO**Gram Menu as shown in Figure 5-2.

### 5.2.2 Passcode Protection

It is possible to protect the programming menu with a Passcode to prevent unauthorized tampering with the unit setup. Once a Passcode is set, any attempt to enter the programming menu by pressing the **PROG** button will bring up a numeric keypad and the user will be prompted for the code. Use the numeric keypad to enter the Passcode and press the **ENTER** button to gain access to the programming menu. To set a Passcode or change a Passcode, refer to Section 5.11.2.

**CAUTION: KEEP YOUR PASSCODE SAFE. IF YOU LOSE IT, THERE IS NO WAY TO CLEAR OR RESET IT.**

### 5.2.3 Program Menu Selections

Once the **PROG** button is pressed, the Program Menu is displayed as shown in Figure 5-2. One of the entries will be highlighted. This is the program option that will be activated when you press the **ENTER** button and is the last menu option used. Use the **UP** (-) or **DOWN** (⏏) button to scroll through the menu options available in the Program Menu then press the **ENTER** button to proceed or the **EXIT** button to return to the Command Button Bar.

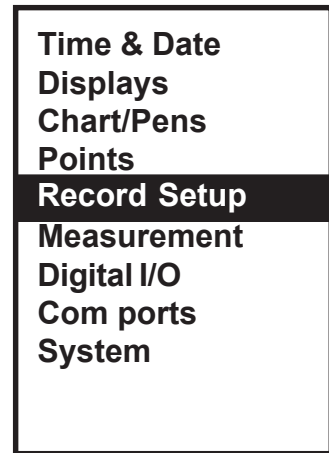

**Figure 5-2  
Program Menu**

## 5.3 Time and Date

The Time and Date menu option sets the Recorder’s internal clock for time and date dependent features such as recording to disk, alarm annotation and records documentation. The time is programmed and displayed in **24-hour format**. The date is programmed and displayed in a Month, Day, Year format. It is recommended that you set the time and date upon system start-up. Time and date are stored in the battery backed up real time clock.

To change the Time or Date:

From the Program menu use the **UP** (↑) or **DOWN** (↓) button to highlight **Time & Date** and then press the **ENTER** button. Follow the prompts are described in the sections below.

### 5.3.1 Time

The display will show the time such as “12:30:25”. If the time is correct, press the **ENTER** or **YES** button to display the date or press the **EXIT** button to return to the Program menu. If the time is incorrect, press the **NO** button and the display will prompt for “hours? →XX←”. Use the **LEFT** (←) or **RIGHT** (→) button to select the digit to be changed, and then use the numeric keypad to enter the current hour (23 is maximum). When the correct hour is displayed, press the **ENTER** button to move on to the minutes (59 is maximum) and then seconds (59 is maximum). Use the same procedure used in programming hours to program the correct minutes and then seconds. Once the time is correct, press the **ENTER** or **YES** button to display the date.

### 5.3.2 Date

Once the time has been accepted, the display will show the date such as “01/01/95”. If the date is correct, press the **ENTER**, **YES** or **EXIT** button to return to the Program menu. If the date is incorrect, press the **NO** button and the display will prompt for “month? →XX←”. Use the **LEFT** (←) or **RIGHT** (→) button to select the digit to be changed, and then use the numeric keypad to enter the current month (12 is maximum). When the correct month is displayed, press the **ENTER** button to move on to the day (31 is maximum) and then year (no maximum). Use the same procedure used in programming the month to program the correct day and year. Once the date is correct, press the **ENTER** or **YES** button to return to the Program menu.

## 5.4 Displays

The Display menu option allows the user to program several items dealing with the way data is displayed on the screen.

To program the Display options:

From the Program menu use the **UP (↑)** or **DOWN (↓)** button to highlight **Displays** and then press the **ENTER** button. The Display menu will be displayed as shown in Figure 5-3. Use the **UP (↑)** or **DOWN (↓)** button to select the option you wish to program and then press the **ENTER** button. The options are described in the following sections.

<b>Display rate</b>
<b>Time format</b>
<b>Powerup disp</b>
<b>Bar assign</b>
<b>Digital assign</b>
<b>Display Colors</b>
<b>Pick Views</b>
<b>Rotate Scales</b>
<b>Screen Dimmer</b>

### 5.4.1 Display rate

The Display rate determines the time lapse between consecutive display updates in the Status Line area when you have chosen to display information other than time and date, such as point or alarm information. The Display rate controls the Auto jog function jog rate, and the display update of a single point or alarm being displayed. The Display rate is programmable from 1 to 60 seconds in one second intervals. The factory default Display rate is one second.

To change the Display rate:

From the Display menu use the **UP (↑)** or **DOWN (↓)** button to highlight **Display rate** and then press the **ENTER** button. The current Display rate will be displayed such as “seconds →10←”. If the Display rate is correct, press the **ENTER** button to return to the Display menu. If you wish to change the Display rate, use the numeric keypad to change the update time and then press the **ENTER** button to accept the programmed Display rate and return to the Display menu.

**Figure 5-3**  
**Display Menu**

### 5.4.2 Time format

The Time format menu option allows the user to program either American or European time format for the display. The difference is in the way the date is displayed; American format is Month/Day/Year while European format is Day/Month/Year.

To change the Time format:

From the Display menu use the **UP (↑)** or **DOWN (↓)** button to highlight **Time format** and then press the **ENTER** button. The current selection will be shown highlighted. Use the **UP (↑)** or **DOWN (↓)** button to select either **American** or **European** and press the **ENTER** button to accept the selection. Then press the **EXIT** button to return to the Display menu.

### 5.4.3 Powerup display (Powerup disp)

The Powerup display menu option allows the user to change what is displayed when the unit is powered up. The options are: Unit tag, Auto jog, Point, Alarms or Junction Temp.

To change the Powerup display:

From the Display menu use the **UP (↑)** or **DOWN (↓)** button to highlight **Powerup disp** and then press the **ENTER** button. You will have five choices: **Unit tag**, **Auto jog**, **Point**, **Alarms** or **Junction Temp**. These options are mutually exclusive, and the current setting will be highlighted. The Powerup display options are described in the following sections.



### 5.4.3.1 Unit tag

The Unit tag is the default display that shows in the Status Line at the top of the display. It may be used to identify a place or process being monitored by the Recorder. The Unit tag can be any number or alpha character string of up to 20 characters.

To select Unit tag as the Powerup display:

Use the **UP** (↑) or **DOWN** (↓) button to highlight **Unit tag** and then press the **ENTER** button. You will be provided with an alphanumeric keypad. Use the **LEFT** (←) or **RIGHT** (→) button to move the cursor to the edit position and then use the alphanumeric keypad to enter the Unit tag you wish to display. The **PAGE** button selects the next page of characters, the **PAGBK** button returns to the previous page of characters, the **SHIFT** button toggles between upper and lower case letters, and the **SPC** button enters a space. When you are done, press the **ENTER** button and then the **EXIT** button to return to the Display menu. You can press the **EXIT** button to cancel at any time without changing the current setting.

### 5.4.3.2 Auto jog

The Auto jog Powerup display jogs (or scrolls) through each programmed point with the point status and value at the programmed Display rate. The programmed Display rate can be 1 to 60 second intervals, programmed under PROGram, Displays, Display rate (see Section 5.4.1).

To select Auto jog as the Powerup display:

Use the **UP** (↑) or **DOWN** (↓) button to highlight **Auto jog** and then press the **ENTER** button. Press the **EXIT** button to return to the Display menu.

### 5.4.3.3 Point

The Point Powerup display allows a programmed point to be displayed as the default Status Window value or the unit prompt. The point number programmed, the current value of that point, and the engineering units will be displayed as the unit Powerup prompt in the Status Line.

To program a programmed point to act as the Powerup display:

Use the **UP** (↑) or **DOWN** (↓) button to highlight **Point** and then press the **ENTER** button. You will be provided with a keypad to select the point you wish to use, 1-9 or A-F. Select the point you want and press the **ENTER** button or press the **EXIT** button to return without changing the point. Press the **EXIT** button again to return to the Display menu.

### 5.4.3.4 Alarms

The Alarms Powerup display will jog (or scroll) through all points in Alarm at the programmed Display rate. If all points are in Alarm, each point will be displayed at the Display rate in the Status Line. If no points are in Alarm, the unit Powerup display will show "NO ALARMS".

To select Alarms as the Powerup display:

Use the **UP** (↑) or **DOWN** (↓) button to highlight **Alarms** and then press the **ENTER** button. Press the **EXIT** button to return to the Display menu.

### 5.4.3.5 Junction Temp

The Junction Temp Powerup display will display the temperature in Degrees F [°F] (Degrees C [°C] with European Time format selected) of the cold junction reference compensator in the Status Line.

To select Junction Temp as the Powerup display:

Use the **UP** (↑) or **DOWN** (↓) button to highlight **Junction Temp** and then press the **ENTER** button. Press the **EXIT** button to return to the Display menu.

### 5.4.4 Bar assign

The Bar assign menu option allows the user to assign specific points to the individual bars in the bar graph display.

To assign points to specific Bars:

From the Display menu use the **UP (↑)** or **DOWN (↓)** button to highlight **Bar assign** and then press the **ENTER** button. You will be prompted with “bar 1 = pt X”. Use the **UP (↑)** or **DOWN (↓)** button to select the point to be assigned to Bar 1 and press the **ENTER** button or press the **EXIT** button to return to the Display menu without affecting the bar. Do the same for Bars 2 - C. Note that selecting “bar X = pt 0” effectively turns the bar off but does not remove it from the display, and the top of Bar X will be blank. Once all Bars have been assigned, press the **EXIT** button to return to the Display menu.

### 5.4.5 Digital assign

The Digital assign menu option allows the user to assign specific points to the individual Digital Displays (Total of 6) in the Digital Window display. The Digital Windows are displayed as two rows of three displays, numbered 1 to 3 across the top and 4 to 6 across the bottom or four rows of 3 for twelve channels.

To assign points to specific Digital Windows:

From the Display menu use the **UP (↑)** or **DOWN (↓)** button to highlight **Digital assign** and then press the **ENTER** button. You will be prompted with “digital 1 = pt X”. Use the **UP (↑)** or **DOWN (↓)** button to select the point to be assigned to Digital Window 1 and press the **ENTER** button or press the **EXIT** button to return to the Display menu without affecting the display. Do the same for Windows 2 - C. Note that selecting “digital X = pt 0” effectively turns the Digital display off but does not remove it from the display, and the top of Digital Window X will be blank. Once all Digital Windows have been assigned, press the **EXIT** button to return to the Display menu.

### 5.4.6 Display Colors (Color Units ONLY)

The Display Colors menu option allows the user to customize the color of specific items on the Trend (or graph view), the Bar Charts and the Digital Windows.

To change the Display Colors:

From the Display menu use the **UP (↑)** or **DOWN (↓)** button to highlight **Display Colors** and then press the **ENTER** button. Use the **UP (↑)** or **DOWN (↓)** button to select the display option to customize. If you choose the Trend Chart Pen or Bargraph Bars, use the **UP (↑)** or **DOWN (↓)** button to select which Pen # or Bargraph # to change and then press the **ENTER** button. A window will appear with a color band. Use the **UP (↑)** or **DOWN (↓)** button to select a color and press the **ENTER** button or the **EXIT** button to return without affecting the display. Do the same for the other Display Color options. Once all colors have been modified, press the **EXIT** button to return to the Display menu.

### 5.4.7 Pick Views

The Pick Views menu option allows the user to select the desired screen views available when the VIEW button is pressed. The Trend View and the Alarm Window are always active.

To Pick Views:

From the Display menu use the **UP (↑)** or **DOWN (↓)** button to highlight **Pick Views** and then press the **ENTER** button. For each view press the **YES** button if you want to see the current view when toggling, or press the **NO** button if you do not want see the current view when toggling. Once you go through all the views, you will be returned to the Display menu.

### 5.4.8 Rotate Scales

The Rotate Scales menu option allows the user to select whether or not the different scales rotate on the graph automatically or manually. In the Auto mode, all programmed scales will rotate at a set interval automatically. In the Manual mode, the displayed scale will not change until the center of the scale is pressed, which will rotate through all programmed scales. NOTE: At any time, the center of the scale can be pressed to rotate to the next programmed scale.

To set the Rotate Scales option:

From the Display menu use the **UP (↑)** or **DOWN (↓)** button to highlight **Rotate Scales** and then press the **ENTER** button. Use the **UP (↑)** or **DOWN (↓)** button to select either **Auto Rotate** or **Manual Rotate** and press the **ENTER** button. Press the **EXIT** button to return to the Display menu.

### 5.4.9 Screen Dimmer

The Screen Dimmer menu option sets the screen brightness and the setting at which the unit will dim or turn off the backlight after a user specified time. The timeout of the four levels (3,2,1 or off) is programmable from 0 to 720 minutes in one minute intervals.

The screen will be at the “Bright Level” when the ACK button is flashing or when the touch screen is pressed. After the dimmer timeout value is reached, the backlight will reduce in intensity to the “Dim Level”. If an Alarm regularly goes off within the Screen Dimmer timeout interval, the display will never go to the “Dim Level”.

To set the Screen Dimmer options:

From the Display menu use the **UP (↑)** or **DOWN (↓)** button to highlight **Screen Dimmer** and then press the **ENTER** button. A window will pop up prompting for the BRIGHT LEVEL. Use the **UP (↑)** or **DOWN (↓)** button to select one of the three Brightness Levels (3, 2, or 1) and press the **ENTER** button. A window will then pop up prompting for the DIM LEVEL value. Use the **UP (↑)** or **DOWN (↓)** button to select a Dim Level and press the **ENTER** button. The Dim Level selection(s) will be one level less than the Brightness Level you set. For example, if you select “2” as the Bright Level, you will be given the choice of “1” or “OFF” for the Dim Level. Next, use the numeric keypad to enter the timeout interval in minutes (0 to 720) and press the **ENTER** button. Setting the timeout value to 0 never dims the backlight.

## 5.5 Chart/Pens

The Chart/Pens menu option allows the user to program parameters directly affecting Charts or Pens.

To program the Chart/Pens options:

From the Program menu use the **UP (↑)** or **DOWN (↓)** button to highlight **Chart/Pens** and then press the **ENTER** button. The Chart/Pens menu will be displayed as shown in Figure 5-4. Use the **UP (↑)** or **DOWN (↓)** button to select the option you wish to program and then press the **ENTER** button. The options are described in the following sections.

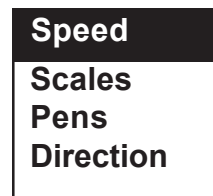

**Figure 5-4**  
**Chart/Pens**  
**Menu**

#### 5.5.1 Speed

The Speed menu option establishes the virtual chart Speed and units (Standard: Inches/Hour or Metric: Millimeters/Hour) at which the virtual chart paper will advance. The display update rate or virtual chart Speed may be set to Autospeed which enables chart Speed to be changed via Alarm condition or external input, or the user can choose Set speeds to set the virtual chart Speed within the following limits:

**Standard** (0.5 in/hr to 600 in/hr)  
 increments of 0.5 from 0.5-10  
 increments of 5 from 10-100  
 increments of 50 from 100-600

**Metric** (10 mm/hr to 15,000 mm/hr)  
 increments of 5 from 10-100  
 increments of 50 from 100-1000  
 increments of 500 from 1000-10,000  
 increments of 1000 from 10,000-15,000

To program the virtual chart Speed options:

From the Chart/Pens menu use the **UP (↑)** or **DOWN (↓)** button to highlight **Speed** and then press the **ENTER** button. Use the **UP (↑)** or **DOWN (↓)** button to highlight **Set speeds** or **Autospeed** and press the **ENTER** button.

#### 5.5.1.1 Set speeds

If **Set speeds** is selected, you will be prompted with either **standard\*** or **metric\***. Press the **ENTER** or **YES** button to accept the current setting or the **NO** button and then **ENTER** or **YES** button to select the other option. You will be prompted with "low speed= XX". Use the **UP (↑)** or **DOWN (↓)** button to select the desired low chart speed and then press the **ENTER** button. You will be prompted with "high speed= XX". Use the **UP (↑)** or **DOWN (↓)** button to select the desired high chart speed and then press the **ENTER** button. Press the **EXIT** button to return to the Chart/Pens menu.

#### 5.5.1.2 Autospeed

If **Autospeed** is selected, use the **YES** or **NO** button to change the display to read **autospd=NO** or **autospd=YES**. When the desired Autospeed option is displayed, press the **ENTER** button. Press the **EXIT** button to return to the Chart/Pens menu.

### 5.5.2 Scales

Scales are used to display and record all or part of the preselected Output scale. The user can effectively zoom all or part of the available range. The user can also configure the grids printed on the display. Two sets of 8 scales A through H can be programmed. Only one of the two sets is active at any given time. The active set can be selected via remote switches or from the front panel using the **FUNCTION**, **Scale set** option.

Each bar graph and/or pen is driven by a point. Any point in the system can be assigned to one or more of the bar graphs and/or pens. A scale from A through H is selected for each point during point programming. Since more than one point can be assigned to each scale, programming of the scale parameters is done separately in the Scales menu. The point assignment connects the bar graphs, pens and display grids with the corresponding scale.

To program a Scale:

From the Chart/Pens menu use the **UP (↑)** or **DOWN (↓)** button to highlight **Scales** and then press the **ENTER** button. You will be prompted with "scale? XX". Use the **UP (↑)** or **DOWN (↓)** button to select the scale to program, 1A through 1H or 2A through 2H, and then press the **ENTER** button. The Scales menu will be displayed with four options: **Scale type**, **Scale ends**, **Scale grid**, **Scale units**. These options are described in the following sections.

#### 5.5.2.1 Scale type

The scale type can be Linear (LIN) or Logarithmic (LOG). For Linear scales, the point data is interpolated linearly across the defined segments. For Log scales, the log 10 of the data is used in the interpolation.

To set the Scale type:

From the Scales menu use the **UP (↑)** or **DOWN (↓)** button to highlight **Scale type** and then press the **ENTER** button. Use the **UP (↑)** or **DOWN (↓)** button to select **type= LIN** for Linear or **type= LOG** for Logarithmic and press the **ENTER** button. Press the **EXIT** button to return to the Scales menu.

#### 5.5.2.2 Scale ends

A low, mid and high end point is programmed for each scale. The low and high end points indicate the values at the left and right margins of the chart and the bottom-most and top-most segments of the bar graph display. The mid point defines the center of the chart and need not be halfway between the low and high values of the scale. If the point data is outside the range between the low and high end-points, the pen is positioned in one of the chart ends and the bar-graph is all-on or all-off. In the case of LOG scales, these

end points are programmed in exponents with an implicit base 10 in the range  $10^{-25}$  to  $10^{25}$ . The graph will be linear between the low and mid points and the mid and high points, and the mid point need not be midway between the low and high points. The graph can thus be made to amplify data by offsetting the midpoint. For example, if the full scale is zero to 10, and low = 0, high = 10 and mid = 8, half the display will show 0 to 8 and the other half will show 8 to 10. Thus the upper half of the display represents only 20% of the chart and will have four times the resolution of the lower half of the display as shown below:

Scale: 0|\_|\_|2\_|\_|4\_|\_|6\_|\_|8\_|\_|9\_|\_|\_|10  
 0 — 1 per division — 50 — 0.25 per division — 100%

To set the Scale ends:

From the Scales menu use the **UP (↑)** or **DOWN (↓)** button to highlight **Scale ends** and then press the **ENTER** button. You will be prompted with “places? X”. Use the **UP (↑)** or **DOWN (↓)** button to select the desired number of decimal places and press the **ENTER** button. You will be prompted with “lo→XXX←”. Use the numeric keypad to set the low scale value and press the **ENTER** button. You will be prompted with “mid→XXX←”. Use the numeric keypad to set the midpoint scale value and press the **ENTER** button. You will be prompted with “hi→XXX←”. Use the numeric keypad to set the high scale value and press the **ENTER** button. The display will return to the Scale menu.

**NOTE:** If the point data falls outside the programmed range of a selected scale, the information recorded will only reflect the upper or lower most value on the scale.

### 5.5.2.3 Scale grid

The scales are shown on top of the chart with the major and minor divisions. The grid printed on the chart is the vertical continuation of the major divisions. For the Log scales, the major and minor divisions are fixed with nine minor and one major division for each decade.

**NOTE:** If the number of decades between the ends and the midpoint of the scale is greater than eight, the minor and major divisions are not printed. If the grids are too fine they may appear as a solid line on the display which may not be able to resolve them.

To program the Scale grid:

From the Scales menu use the **UP (↑)** or **DOWN (↓)** button to highlight **Scale grid** and then press the **ENTER** button. You will be prompted with “lo major→XX←” which is the number of vertical grids that will be printed on the screen. Use the numeric keypad to enter the desired number of major grids and press the **ENTER** button. You will be prompted with “lo minor→XX←” which is the number of vertical stripes that will be printed between the major grids on the screen. Use the numeric keypad to enter the desired number of minor grids and press the **ENTER** button. Repeat for “hi major→XX←” and “hi minor→XX←”.

### 5.5.2.4 Scale units

A five character Engineering units field can be programmed for each scale, which is shown at the top of the graph. This Scale unit along with the Engineering units is also recorded to disk. The same line also identifies the pens trending in the scale with the point number associated to each pen.

To program the Scale units:

From the Scales menu use the **UP (↑)** or **DOWN (↓)** button to highlight **Scale units** and then press the **ENTER** button. You will be prompted with “units→XXXXX←”. Use the alphanumeric keypad to enter the desired Scale units and press the **ENTER** button to return to the Scale menu.

### 5.5.3 Pens

Using the Pens menu, any point programmed into the Recorder can be assigned to any of the pens. The pens draw the actual traces on the display and are not necessarily the points recorded to disk. You also have the option to assign any abnormal pen condition (Overrange, TCBO, etc.) to go high or go low and to select the width of the pen being displayed on the graph.

To program the Pens:

From the Chart/Pens menu use the **UP (↑)** or **DOWN (↓)** button to highlight **Pens** and then press the **ENTER** button. You will have three choices: **Pens assign**, **Abnorm. pen**, **Trace Width**. The options are described in the following sections.

#### 5.5.3.1 Pens assign

To assign a point to a Pen:

Use the **UP (↑)** or **DOWN (↓)** button to highlight **Pens assign** and press the **ENTER** button. The display will read "pen 1 = pt X". Use the **UP (↑)** or **DOWN (↓)** button to select the point to assign to pen 1 and press the **ENTER** button. Repeat to assign points to pens 2-C. You need not program all pens. Any pen programmed to point 0 will be turned off. At any time you may press the **EXIT** button to cancel any changes.

#### 5.5.3.2 Abnorm. Pen

Any time a pen goes into an abnormal condition (Overrange, TCBO, etc.), the pen can go full scale if high is selected or low scale if low is selected.

To set the Abnormal Pen condition:

Use the **UP (↑)** or **DOWN (↓)** button to highlight **Abnorm. pen** and press the **ENTER** button. Use the **UP (↑)** or **DOWN (↓)** button to select **abnorm. pen high** or **abnorm. pen low** and press the **ENTER** button. Press the **EXIT** button to return to the Pens menu.

#### 5.5.3.3 Trace Width

The pen trace widths can be changed from 1 to 7 pixels wide. This value changes all pens displayed.

To change the pen Trace Width:

Use the **UP (↑)** or **DOWN (↓)** button to highlight **Trace Width** and press the **ENTER** button. Use the **UP (↑)** or **DOWN (↓)** button to select a width value (in pixels) and press the **ENTER** button or press the **EXIT** button to cancel any changes.

### 5.5.4 Direction

Direction determines whether the traces on the Trend View move in a vertical or horizontal direction. The direction may be changed at any time without affecting the recording or the browse buffer.

To change the direction of the chart:

From the Chart/Pens menu, use the **UP (↑)** or **DOWN (↓)** button to highlight **Direction** and press the **ENTER** button. Use the **UP (↑)** or **DOWN (↓)** button to select either **vertical** or **horizontal** and press the **ENTER** button. The chart will change direction immediately, clearing the screen and beginning a new trace. Press the **EXIT** button to return to the Chart/Pens menu.



## 5.6 Points

The Points menu option allows the user to program parameters directly affecting Points. The Points are the actual channels in the Recorder and may be direct inputs, conditioned direct inputs (scaled or adjusted), computational channels or external (serial) inputs for a total of 15.

To program Points:

From the Program menu use the **UP** (↑) or **DOWN** (↓) button to highlight **Points** and then press the **ENTER** button. The Points menu will be displayed as shown in Figure 5-5. Use the **UP** (↑) or **DOWN** (↓) button to select the option you wish to program and then press the **ENTER** button. The options are described in the following sections.



The image shows a rectangular menu box with a black background and white text. The text is arranged in two lines: "Prog point" on the top line and "Constants" on the bottom line. The box has a thin white border.

**Figure 5-5**  
Points Menu

### 5.6.1 Constants

The Constants menu option allows the user to program up to fifteen different constants for use in equations for point programming. These Constants, referred to as K<sub>x</sub> (where x = 1 to 9, A to F), are substituted into equations instead of writing the Constant value. This simplifies programming an equation.

To program Constants:

From the Points menu use the **UP** (↑) or **DOWN** (↓) button to highlight **Constants** and press the **ENTER** button. A keypad with the Constants 1 to 9 and A to F will be displayed. Press the desired Constant number and press the **ENTER** button. Use the numeric keypad to program the desired Constant value for the selected Constant number. Only a total of 13 characters including decimal points are available and will show on display. The Constants are entered in decimal (0.002345) or exponential (2.345E-3) format and may be positive or negative. When the desired value for the Constant is programmed, press the **ENTER** button or press the **EXIT** button to cancel. Repeat for each Constant. Once all Constants are programmed, press the **EXIT** button to return to the Points menu.

### 5.6.2 Programming Points

The Prog point menu option allows the user to setup, copy, restore, modify, or delete a point's parameters. The programming sequence follows a general order for custom programming and the system prompts you to submit various parameters.

To Program a Point:

From the Points menu use the **UP** (↑) or **DOWN** (↓) button to highlight **Prog point** and press the **ENTER** button. You will be prompted with "point? x". Use the numeric keypad (1 - 9, A - F) to enter the point to be programmed or modified and press the **ENTER** button. For unprogrammed points you will have three Point programming options: **Setup pt**, **Copy pt** and **Restore pt**. If the point has already been setup, you will have two Point programming options: **Modify pt** and **Delete pt**. See the following sections for more details.

**NOTE:** If at any point you exit the Points programming menu after having made any changes, (repeatedly pressing exit) you will be prompted with the message "keep setup?". If you select **NO** at this time, any changes you have just made will be lost. If you choose **YES**, the changes you made will be applied to the point.

### 5.6.3 Point Programming Options

After a point number is chosen, if the point is a new point to program, the point can be setup from scratch, copied from another point already setup, or restored if the point had been setup previously and then deleted. If the point chosen has already been setup, the point parameters may be modified or the point may be deleted.

#### 5.6.3.1 Setup an Unprogrammed Point (Setup pt)

After selecting which point to program, use the **UP** (↑) or **DOWN** (↓) button to highlight **Setup pt** and press the **ENTER** button. The first step in programming a point is to set the Point Type (see Section 5.6.4).

### 5.6.3.2 Setup a Point by Copying (Copy pt)

After selecting the point you wish to copy to, use the **UP** (↑) or **DOWN** (↓) button to highlight **Copy pt** and press the **ENTER** button. You will be prompted with “from pt? X”. Use the **UP** (↑) or **DOWN** (↓) button to select the desired point number, 1 - 9 or A - F, from which to copy the point parameters, and then press the **ENTER** button. You may continue programming to change the point parameters as needed.

### 5.6.3.3 Setup a Point by Restoring (Restore pt)

After selecting the point you wish to restore, use the **UP** (↑) or **DOWN** (↓) button to highlight **Restore pt** and press the **ENTER** button. You may continue programming to change the point parameters as needed.

**NOTE:** To restore a point, that point must have been previously programmed and still be in the system memory. If the point was not previously programmed you will get a “PT NEVER SET” message.

### 5.6.3.4 Modify an Existing Point (Modify pt)

After selecting the point you wish to modify, use the **UP** (↑) or **DOWN** (↓) button to highlight **Modify pt** and press the **ENTER** button. You may continue programming to change the point parameters as needed.

### 5.6.3.5 Delete an Existing Point (Delete pt)

After selecting the point you wish to delete, use the **UP** (↑) or **DOWN** (↓) button to highlight **Delete pt** and press the **ENTER** button. You will be prompted with “confirm del?”. Press the **ENTER** or **YES** button to delete the point. Press the **NO** or **EXIT** button to cancel deleting the point.

## 5.6.4 Programming Point Types

There are various Point Types that can be selected from simple Linear to complex equations. Once a point has been selected to Setup or Modify, the Point Type menu will be displayed as shown in Figure 5-6. Use the **UP** (↑) or **DOWN** (↓) button to select the desired Point Type and then press the **ENTER** button. Some Point Types will display a sub-menu with more specific options. Again, use the **UP** (↑) or **DOWN** (↓) button to select the specific Point Type and then press the **ENTER** button. The Point Types available are:

- Linear** - Basic voltage and current input with linear scaling or dry contacts
- Industrial Square Root (Ind sqrt)** - Performs square root extraction on input
- Log linear** - Performs inverse logarithm on input
- Rtd** - Resistance Temperature Devices as defined
- Calculated** - Derived channels from user entered algorithms
- Conditional** - Boolean logic channels
- External** - Input channel via comm port

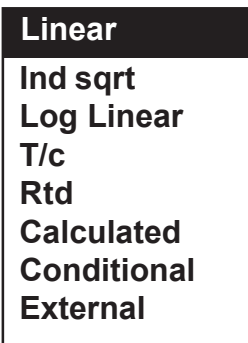

Figure 5-6  
Point Type Menu

## 5.6.5 Programming Parameters

Depending on the Point Type selected, various programming parameters will be available in the Point Setup Menu. Each of the possible parameters are described in the following sections.

### 5.6.5.1 Point tag

A Point tag is a name used to identify the point on the display or recorded file. It may be up to ten characters long of which only eight will display on the screen. The Point tag appears on the bar graphs and digital displays.



To program a Point tag:

From the Point Setup menu use the **UP** (↑) or **DOWN** (↓) button to highlight **Point tag** and press the **ENTER** button. The display will show the existing Point tag, if any, as “→POINT TAG ←”. Use the alphanumeric keypad to enter up to ten characters for your desired Point tag and then press the **ENTER** button to return to the Point Setup menu.

### 5.6.5.2 Input scale

The low and high Input scale is used for configuring the Recorder for the actual input provided by the transducer. If the input range full scale, e.g. 12.5V, exceeds the actual input signal, say 5V, only half the input range is actually used. By adjusting the Input scale setting to be 0 to 5V, the entire input range is used for 5V. Note that the resolution is halved. Only voltage inputs require setting low and high input range values.

**NOTE:** During point programming, input range voltages are programmed in the same engineering units as the voltage range selected, i.e. mV or Volts.

To program the point Input scale:

From the Point Setup menu use the **UP** (↑) or **DOWN** (↓) button to highlight **Input scale** and press the **ENTER** button. You will be prompted with “lo→XXXXXXXXXXXXX←” (13 places possible). Use the numeric keypad to enter the low end scale value (the default is zero) and then press the **ENTER** button. You will be prompted with “hi→XXXXXXXXXXXXX←”. Use the numeric keypad to enter the high end scale value (the default is the full scale value of the range selected) and then press the **ENTER** button to return to the Point Setup menu.

### 5.6.5.3 Output scale

All linear current and voltage inputs must be assigned low and high Output scale endpoints. The Output scale is used to linearly map the input range (set with the Input scale option) to an output range set with the Output scale option. For example, if a transducer has a 1 volt output equivalent to 5000 PSI, use the 1.25V input range with an input range setting of 0 to 1.00 V and program the output range to be 0 to 5000. The actual readings on the display will then be in PSI.

To program the point Output scale:

From the Point Setup menu use the **UP** (↑) or **DOWN** (↓) button to highlight **Output scale** and press the **ENTER** button. You will be prompted with “places? X”. Use the **UP** (↑) or **DOWN** (↓) button to set the desired number of decimal places (up to a maximum of 4, NOTE: 5 = E notation) and press the **ENTER** button. You will be prompted with “lo→XXXXXXXXXXXXX←” (13 places possible). Use the numeric keypad to enter the low end scale value (the default is zero) and then press the **ENTER** button. You will be prompted with “hi→XXXXXXXXXXXXX←”. Use the numeric keypad to enter the high end scale value (the default is the full scale value of the range selected, which is a direct linear mapping or a scaling of 1) and then press the **ENTER** button to return to the Point Setup menu.

### 5.6.5.4 Exc. Currents

Currents are used to measure a resistance input on the back of the Recorder. If a resistance other than an RTD is plugged into an input, Exc. Currents must be enabled. The Current is typically 1.00mA.

To enable or disable Exc. Currents:

From the Point Setup menu use the **UP** (↑) or **DOWN** (↓) button to highlight **Exc. Currents** and press the **ENTER** button. Press the **YES** or **NO** button to select the desired state of Exc. Currents to either **currents=YES** or **currents=NO** and then press the **ENTER** button to return to the Point Setup menu.

### 5.6.5.5 Decimal fix

Certain points must be assigned a decimal place of up to four places or scientific notation. The choices are:

- 0 = X (no decimal places)
- 1 = X.X
- 2 = X.XX
- 3 = X.XXX
- 4 = X.XXXX
- 5 = Scientific Notation (Decimal places affect displayed point data values only)

To program the Decimal fix:

From the Point Setup menu use the **UP (↑)** or **DOWN (↓)** button to highlight **Decimal fix** and press the **ENTER** button. You will be prompted with “places? X”. Use the **UP (↑)** or **DOWN (↓)** button to set the desired number of decimal places and press the **ENTER** button to return to the Point Setup menu.

**NOTE:** Thermocouple (T/C) points must be assigned a decimal place of either 1 or 0. This enables temperature to be displayed with a resolution of either 1 degree (0) or 0.1 degree (1).

### 5.6.5.6 Filter

The digital Filter smooths noisy or erratic signals by attenuating the effects of sudden transitions. The digital Filter is programmable from 0 to 30 seconds in one second increments (nominal).

To program the digital Filter:

From the Point Setup menu use the **UP (↑)** or **DOWN (↓)** button to highlight **Filter** and press the **ENTER** button. You will be prompted with “seconds→XX←”. Use the numeric keypad to enter the required number of seconds (maximum 30) and then press the **ENTER** button to return to the Point Setup menu.

### 5.6.5.7 Compensation

Thermocouple Compensation can be Local, from the cold reference junction temperature sensor built into the Recorder, or External through a direct input. When thermocouples are compensated Locally, the temperature sensor (located on the rear terminal panel of the Recorder) measures the ambient temperature of the cold junction. For remote compensation, a single Thermocouple or RTD can be used to measure the ambient temperature of the remote junction box. This method allows several thermocouple points to be measured without using thermocouple extension wire for each input. The point used as the measurement source of the remote cold junction source is referred to as the compensation channel. The point used as the compensation channel must be programmed **before** the Thermocouple or RTD input is assigned to it.

To program the Compensation:

From the Point Setup menu use the **UP (↑)** or **DOWN (↓)** button to highlight **Compensation** and press the **ENTER** button. Use the **UP (↑)** or **DOWN (↓)** button to select either **Local comp** or **Ext comp** and press the **ENTER** button. If **Local comp** is chosen, just press the **EXIT** button to return to the Point Setup menu. If **Ext comp** is chosen, you will be prompted with “ext point? X”. Use the **UP (↑)** or **DOWN (↓)** button to scroll through the point numbers to choose the input where the external compensation is input. When the desired point number is displayed, press the **ENTER** button. Then press the **EXIT** button to return to the Point Setup menu.

### 5.6.5.8 Span/offset

In order for the Span/offset menu option to be available, the user must turn this feature on in the PROGRAM, Measurement, Span&offset menu option (see Section 5.8.2). Once this option has been turned on, the user can use Span and Offset to compensate for long thermocouple cable runs or thermocouple inaccuracies. The default value for Span is 1 and the default value for Offset is 0. The Span is a multiplier of the absolute thermocouple range. The Offset is a value of absolute degrees which is added or subtracted to the thermocouple reading. Once Span and Offset have been entered, the new adjusted range will be:

$$\text{New T/C Range} = (\text{Full Scale} * \text{SPAN}) + \text{OFFSET}$$

Note that Span is a multiplier while Offset is an additive.

To adjust the Span and Offset:

Make sure the Span&offset option has been turned on. From the Point Setup menu use the **UP (↑)** or **DOWN (↓)** button to highlight **Span/offset** and press the **ENTER** button. You will be prompted with “ofs → 0.0000←”. Use the numeric keys to enter a value for the offset which will be added or subtracted to the thermocouple value and then press the **ENTER** button. Note that offset is typically measured around the ice point which should be 0 °C or 32 °F. The offset would typically be the difference between the thermocouple reading at this point and the true ice point value. You will then be prompted with “spn → 1.00000←”. Use the numeric keypad to enter the new span value and then press the **ENTER** button. The span should typically be measured near the full scale value of the thermocouple using a known temperature or reference. The span would be the absolute value of the reference divided by the reading of the thermocouple. You will be returned to the Point Setup menu.

### 5.6.5.9 Engineering (Eng) units

An Engineering units message with a maximum of five alphanumeric characters may be assigned for voltage and current inputs to identify the point, e.g. PSI or mA.

To program Engineering units:

From the Point Setup menu use the **UP (↑)** or **DOWN (↓)** button to highlight **Eng units** and press the **ENTER** button. You will be prompted with “units→XXXXX←”. Use the alphanumeric keypad to enter up to five characters for your desired Engineering units and then press the **ENTER** button to return to the Point Setup menu.

### 5.6.5.10 Alarms

A total of five Alarms can be set for each point programmed. These five Alarms can be any combination of numerous Alarm types (limits). The Alarm deadband (also known as hysteresis) and Alarm delay can also be programmed for each Alarm set.

To program Alarms:

From the Point Setup menu use the **UP (↑)** or **DOWN (↓)** button to highlight **Alarms** and press the **ENTER** button. The Alarm Setup menu will display up to three choices: **Alm limits**, **Alm deadband**, and **Alm delay**. Each option is described in the following sections.

### 5.6.5.10.1 Alarm limits (types)

For all inputs other than Linear Dry Contact or Conditional, the Alarm types are: None, High, Low, Rate, or Abnormal. For Linear Dry Contacts the Alarm types are: None, Open, Close or Abnormal. For Conditional Inputs, the Alarm types are: None, True, False or Abnormal. The Alarm types are described below:

<b>None</b>	No alarm set
<b>High</b>	Set High alarms (up to five). Alarm will occur if input is greater than the Alarm set point.
<b>Low</b>	Set Low alarms (up to five). Alarm will occurs if input is less than the Alarm set point.
<b>Rate</b>	Set Rate alarms (up to five). Alarm will occur if the input changes by more than the set point value in the specified time.
<b>Abnormal</b>	Set alarms for Abnormal conditions (TCBO, Overflow, invalid etc.)
<b>Open</b>	Set alarm on Open contact (Linear Dry Contact inputs ONLY)
<b>Close</b>	Set alarm on Closed contact (Linear Dry Contact inputs ONLY)
<b>True</b>	Set alarm if condition is True as defined (Conditional inputs ONLY)
<b>False</b>	Set alarm if condition is False as defined (Conditional inputs ONLY)

If you try to program an alarm with an illegal condition, for example, setting a Linear Voltage input alarm to “Type=close”, you will get an ILLOGICAL error.

To set an Alarm limit (type):

From the Point Setup menu use the **UP (↑)** or **DOWN (↓)** button to highlight **Alm limits** and press the **ENTER** button. You will be prompted with “alarm #? X”. Use the **UP (↑)** or **DOWN (↓)** button to select which Alarm number (1 through 5) you want to set and then press the **ENTER** button. The Alarm Type menu will be displayed as shown in Figure 5-7 with the current setting highlighted. Note that the Alarm Type menu displays all Alarm types, but not all types are valid for all Point Types.

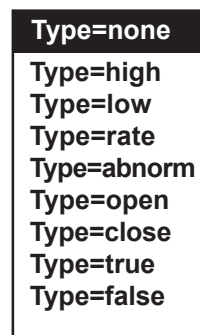

**Figure 5-7  
Alarm Type  
Menu**

#### a. Type=None

If the Alarm type is set to none, the alarm function will be disabled. Use the **UP (↑)** or **DOWN (↓)** button to highlight **Type=none** and press the **ENTER** button. Press the **EXIT** button to return to the Alarm Setup menu.

#### b. High Alarm Type

High Alarms become active when the input exceeds (is greater than) the set point.

To set the Alarm Type as High:

Use the **UP (↑)** or **DOWN (↓)** button to highlight **Type=high** and press the **ENTER** button. You will be prompted with “high→XX.XX←”. Use the numeric keypad to enter the High Alarm value and press the **ENTER** button. You will be prompted with “contact #? X”. This is the contact output that will respond to this alarm provided the relay option is fitted. If no contact output is required, select contact # 0. Use the **UP (↑)** or **DOWN (↓)** button to select the desired contact number (0 to 6) and press the **ENTER** button. The display will return to the Alarm Type menu. Press the **EXIT** button to return to the Alarms Setup menu.

### c. Low Alarm Type

Low Alarms become active when the input is lower than the set point.

To set the Alarm Type as Low:

Use the **UP** (↑) or **DOWN** (↓) button to highlight **Type=low** and press the **ENTER** button. You will be prompted with “low→XX.XX←”. Use the numeric keypad to enter the Low Alarm value and press the **ENTER** button. You will be prompted with “contact #? X”. This is the contact output that will respond to this alarm provided the relay option is fitted. If no contact output is required, select contact # 0. Use the **UP** (↑) or **DOWN** (↓) button to select the desired contact number (0 to 6) and press the **ENTER** button. The display will return to the Alarm Type menu. Press the **EXIT** button to return to the Alarms Setup menu.

### d. Rate Alarm Type

Rate Alarms become active when the input changes more than the set amount within the set time frame. In other words, the rate of change of the input exceeds the set point. The Rate Alarm requires the user to enter a value and a time.

To set the Alarm Type to Rate:

Use the **UP** (↑) or **DOWN** (↓) button to highlight **Type=rate** and press the **ENTER** button. You will be prompted with “rate→XX.XX←”. This is the value of change per time. Use the numeric keypad to enter the Rate Alarm value and press the **ENTER** button. You will be prompted with “seconds→XX←” where XX is 1 by default for a new alarm. Use the numeric keypad to enter the time period for evaluating the rate change, up to a maximum of 600 seconds (ten minutes), and press the **ENTER** button. You will be prompted with “contact #? X”. This is the contact output that will respond to this alarm provided the relay option is fitted. If no contact output is required, select contact # 0. Use the **UP** (↑) or **DOWN** (↓) button to select the desired contact number (0 to 6) and press the **ENTER** button. The display will return to the Alarm Type menu. Press the **EXIT** button to return to the Alarms Setup menu.

### e. Abnormal Alarm Type

An Abnormal Alarm is a condition that exceeds any of the bounds of normal operation. This includes overflow and underflow errors, invalid data and TCBO (ThermoCouple Burn Out).

To set an Abnormal Alarm:

Use the **UP** (↑) or **DOWN** (↓) button to highlight **Type=abnorm** and press the **ENTER** button. You will be prompted with “contact #? X”. This is the contact output that will respond to this alarm provided the relay option is fitted. If no contact output is required, select contact # 0. Use the **UP** (↑) or **DOWN** (↓) button to select the desired contact number (0 to 6) and press the **ENTER** button. The display will return to the Alarm Type menu. Press the **EXIT** button to return to the Alarms Setup menu.

### f. Open or Closed Alarm Types

**NOTE:** Open and Close Alarm Types are available for the Linear, Dry Contact Point type ONLY.

Open and Closed Alarms become active when an input is Open or Closed respectively. No set point is required.

To set an Open or Closed Alarm Type:

Use the **UP** (↑) or **DOWN** (↓) button to highlight **Type=open** or **Type=closed** as desired and press the **ENTER** button. You will be prompted with “contact #? X”. This is the contact output that will respond to this alarm provided the relay option is fitted. If no contact output is required, select contact # 0. Use the **UP** (↑) or **DOWN** (↓) button to select the desired contact number (0 to 6) and press the **ENTER** button. The display will return to the Alarm Type menu. Press the **EXIT** button to return to the Alarms Setup menu.

### g. True or False Alarm Types

**NOTE:** True and False Alarm Types are available for Conditional Point types ONLY.

True and False Alarm conditions become active when a Boolean expression is True or False respectively. No set point is required.

To set a True or False Alarm Type:

Use the **UP** (↑) or **DOWN** (↓) button to highlight **Type=true** or **Type=false** as desired and press the **ENTER** button. You will be prompted with “contact #? X”. This is the contact output that will respond to this alarm provided the relay option is fitted. If no contact output is required, select contact # 0. Use the **UP** (↑) or **DOWN** (↓) button to select the desired contact number (0 to 6) and press the **ENTER** button. The display will return to the Alarm Type menu. Press the **EXIT** button to return to the Alarms Setup menu.

#### 5.6.5.10.2 Alarm deadband

An Alarm deadband can be set for each alarm set. The Alarm deadband is also called hysteresis and is an amount added or subtracted (depending whether the Alarm is Low or High) to the actual set point to determine the reset point. It is primarily intended to reject noise about a set point. For example, if a High Alarm set point is at 50 and the deadband is set at 5, the Alarm will trigger when the input exceeds 50 but will not clear (reset) until the input reaches 45 (set point minus hysteresis).

To set the Alarm deadband (hysteresis):

From the Alarms Setup menu use the **UP** (↑) or **DOWN** (↓) button to highlight **Alm deadband** and press the **ENTER** button. You will be prompted with “db→X.XXX←”. Use the numeric keypad to enter the desired deadband value in absolute Engineering units and press the **ENTER** button. The display will return to the Alarms Setup menu.

#### 5.6.5.10.3 Alarm delay

An Alarm delay can be set for each alarm set. This delay prevents the Alarms from activating until the set time has elapsed from an Alarm active condition. If the Alarm condition goes away before the delay is up, the Alarm will not respond. The delay retriggers. If the Alarm condition goes away before the delay is up and then returns, the delay is reset and the full delay period will expire before the Alarm becomes active. This feature can be used to overcome spurious or transient Alarm conditions.

To set the Alarm delay:

From the Alarms Setup menu use the **UP** (↑) or **DOWN** (↓) button to highlight **Alm delay** and press the **ENTER** button. You will be prompted with “seconds→XXXX←”. Use the numeric keypad to enter the desired delay, up to a maximum of 600 seconds (ten minutes), and press the **ENTER** button. The display will return to the Alarms Setup Menu.

#### 5.6.5.11 Chart scale

Each point must be assigned to a Chart scale. The Chart scale is used to control the display of the output signal and can be used to display or record only part of the output, the area of interest, or across the entire range. There are two sets of eight Chart scales available. A Chart scale can be assigned to multiple points.

To set the Chart scale:

From the Point Setup menu use the **UP** (↑) or **DOWN** (↓) button to highlight **Chart scale** and press the **ENTER** button. You will be prompted with “chart scl= X”. Use the **UP** (↑) or **DOWN** (↓) button to select the desired Chart scale numeral (A through H) and press the **ENTER** button. The display will return to the Point Setup menu.



### 5.6.5.12 Output mode

The Output mode option allows the user to program a point to display the Time Period Average or Rate of Change.

To program the Output mode:

From the Point Setup menu use the **UP (↑)** or **DOWN (↓)** button to highlight **Output mode** and press the **ENTER** button. The Output mode Setup menu will be displayed with five choices: **Normal** (Time Period Average) and **Rate of chg/sec**, **Rate of chg/min**, **Rate of chg/hr** or **Rate of chg/day** (Rate of Change-ROC). These options are mutually exclusive, and the highlighted option is the one that is active. The options are described in the following sections.

#### 5.6.5.12.1 Time Period Average (Normal)

Using Time Period Averaging the Recorder is set up to acquire input data and display the values of the average over a selectable time period (0-3600 seconds). For a time period window of less than or equal to 60 seconds, data points are averaged over 1 second periods. The averages of the short 1 second periods for the selected time periods are then averaged to get a composite average. The recording and display are then updated every 1 second.

For time periods greater than 60 seconds, data points are averaged over a proportionately greater period than 1 second. These averages are then averaged as a composite average. When the maximum setting of 3600 seconds (1 hour) is used, the recording and display update rate is 1 minute.

To set up a point to Time Period Average:

From the Output mode Setup menu use the **UP (↑)** or **DOWN (↓)** button to select **Normal** and press the **ENTER** button. You will be prompted with "seconds→XXXX←". Use the numeric keypad to enter a Time Period value and press the **ENTER** button to return to the Output mode Setup menu. If the Time Period is set to 0, live data readings are recorded without averages.

**NOTE:** Changing between Point Types or to a Point Type that does not support the Time Period Average function resets any previous setting back to the default state.

#### 5.6.5.12.2 Rate of Change (ROC)

The Rate of Change function takes the difference between the current input value and the last Time Period Averaged point or the last real value (if the time period is set to 0). The difference is then scaled to per second, minute, hour or day depending on menu selection. This gives a  $\Delta\text{Value} / \Delta\text{time}$  plot.

To set up a point to display the Rate of Change (ROC):

From the Output mode Setup menu use the **UP (↑)** or **DOWN (↓)** button to select **Rate of chg/sec**, **Rate of chg/min**, **Rate of chg/hr**, or **Rate of chg/day** depending on the scaling preference and press the **ENTER** button. Use the numeric keypad to enter a Time Period value and press the **ENTER** button to return to the Output mode Setup menu. If the Time Period is set to anything other than 0, the Rate of Change (ROC) will be based on the Time Period Averaged point. If the Time Period is set to 0, the Rate of Change (ROC) will be based on the last real value.

### 5.6.5.13 Set equation

The Set equation option is only available for Calculated-Equation points. The user can program equations using the following symbols:

P1 to PF	are used to represent Points (must be previously programmed)
K1 to KF	are used to represent Constants (must be previously programmed)
)	is a RIGHT Parenthesis
+	is Add
-	is Subtract
*	is Multiply
/	is Divide
^	is Fractional
**	is Raise to the Power ( $X^Y$ )
Sq	is Square Root
Ln	is Natural Logarithm
Lg	is Base Ten Logarithm
Ex	is Exponentiation ( $e^x$ )
(	is a LEFT Parenthesis

To Set an equation:

From the Point Setup menu use the **UP** (↑) or **DOWN** (↓) button to highlight **Set equation** and press the **ENTER** button. Use the **UP** (↑) or **DOWN** (↓) button to scroll through the equation symbols until you reach the desired symbol. Then use the **RIGHT** (→) button to move the cursor to the next position. Continue using the **UP** (↑) or **DOWN** (↓) button to select the symbols and the **LEFT** (←) or **RIGHT** (→) button to move the cursor until the equation is complete. Forty (40) positions are available for equation operators, and the display will scroll to the left or right to allow entry. Any equation entered is parsed from left to right. That part of the equation between any parenthesis is calculated first, then the basic rules of mathematics are obeyed. When the desired equation is displayed, press the **ENTER** button to return to the Point Setup menu.

### 5.6.5.14 Basepoint

A Basepoint must be established on which to perform the Hi peak, Lo peak or Time average calculations.

To establish a Basepoint:

From the Point Setup menu use the **UP** (↑) or **DOWN** (↓) button to highlight **Basepoint** and press the **ENTER** button. You will be prompted with "base pt? X". Use the **UP** (↑) or **DOWN** (↓) button to select the desired point to be the Basepoint and press the **ENTER** button. The display will return to the Point Setup menu.

### 5.6.5.15 Reset control

Reset control applies only to Calculated Point Types of the following Point ranges: Hi peak, Lo peak, Time average, Gated timer, and Totalize. The Reset control menu options allow the user to set the Auto reset time intervals, program an Event reset, or print the Reset data. For example, the user can choose to have a Totalizer automatically reset to zero every hour or have it reset only by means of an external Event (digital input).

To program the Reset control options:

From the Point Setup menu use the **UP** (↑) or **DOWN** (↓) button to highlight **Reset contrl** and press the **ENTER** button. The Reset control menu will be displayed with three options: **Auto reset**, **Event reset**, and **Reset print**. Each option is described in the following sections.



**5.6.5.15.1 Auto reset**

When programming High peak, Low peak, Time average, Gated timer and Totalize points, the system allows an Auto reset function. If Auto reset is disabled, resettable points may only be reset manually. If Auto reset is set up, the point being programmed will reset at programmed intervals, from once a minute to once a month.

**NOTE:** High peak, Low peak and Moving average points reset to the current value of the Basepoint. Totalize points reset to zero.

To set the Auto reset function:

From the Reset control menu use the **UP (↑)** or **DOWN (↓)** button to highlight **Auto reset** and press the **ENTER** button. The Auto reset Setup menu will be displayed with the following options: **Auto off**, **Daily**, **Weekly**, or **Monthly**.

**a. Auto off**

If the Auto reset is set to off, automatic reset of the programmed point will be disabled. Use the **UP (↑)** or **DOWN (↓)** button to highlight **Auto off** and press the **ENTER** button. Press the **EXIT** button to return to the Reset control menu.

**b. Daily**

When programming the Auto reset to Daily, the system will prompt for the start time and interval for which that point will reset. The programmable start time is not necessarily the time at which the first reset will occur. However, a reset will always occur at the start time every day. The actual first reset depends upon the current time and the programmed interval. The Recorder calculates the first reset by repeatedly adding the interval to the start time until the current time is met or exceeded. See the example below:

**Current Time:** 07:30  
**Start Time:** 09:15  
**Timed Interval:** 1 Hour

09:15	Programmed Start Time
10:15	
11:15	
12:15	Note: The Interval (1 hour) added to the Start Time yields reset times.
.	
23:15	
00:15	
01:15	
.	
07:15	07:30 (Current Time)
08:15	Time of the first reset for this example

To reset a point Daily:

Use the **UP (↑)** or **DOWN (↓)** button to highlight **Daily** and press the **ENTER** button. You will be prompted with “start XX:XX:XX” The start time is entered in a 24-hour clock format in Hours (00 through 23), Minutes (00 through 59) and Seconds (00 through 59). This is the time the first reset will begin. After the start time the point will reset at the interval rate.

If the start time is correct, press the **ENTER** or **YES** button to proceed to the interval. If the start time is not correct, press the **NO** button. You will be prompted with “start hrs→XX←”. Use the numeric keypad to enter the desired start hours (00 to 23) and press the **ENTER** button. You will be prompted with “start mins→XX←”. Use the numeric keypad to enter the desired start minutes (00 to 59) and press the **ENTER** button. You will be prompted with “start secs→XX←”. Use the

numeric keypad to enter the desired start seconds (00 to 59) and press the **ENTER** button. The programmed start time will be displayed. If the start time displayed is correct, press the **ENTER** or **YES** button to proceed to the interval.

After the start time is set, you will be prompted with "intrvl XX:XX:XX". If the displayed interval time is correct, press the **ENTER** or **YES** button to return to the Auto reset setup menu. If the interval time is not correct, press the **NO** button. You will be prompted with "intrvl hrs→XX←". Use the numeric keypad to enter the desired interval hours (00 to 23) and press the **ENTER** button. You will be prompted with "intrvl mins→XX←". Use the numeric keypad to enter the desired interval minutes (00 to 59) and press the **ENTER** button. You will be prompted with "intrvl secs→XX←". Use the numeric keypad to enter the desired interval seconds (00 to 59) and press the **ENTER** button. The programmed interval time will be displayed. If the interval time displayed is correct, press the **ENTER** or **YES** button to return to the Auto reset setup menu. Press the **EXIT** button to return to the Reset control menu.

**NOTE:** When programming a Totalize Point, the interval represents the frequency of which the Totalization value will be reset to zero. The Totalization value will be logged on the Alarm/Event data log before the value is reset if the Reset print option is enabled.

**NOTE:** When programming a High peak or Low peak Point, the interval represents the frequency the High or Low peak value will be reset to the value of the Basepoint. The High or Low peak value will be logged on the Alarm/Event data log before the value is reset if the Reset print option is enabled.

### c. Weekly

To reset a point Weekly:

Use the **UP** (↑) or **DOWN** (↓) button to highlight **Weekly** and press the **ENTER** button. Use the **UP** (↑) or **DOWN** (↓) button to select **Monday, Tuesday, Wednesday, Thursday, Friday, Saturday, or Sunday** and press the **ENTER** button. You will be prompted with "start XX:XX:XX".

If the start time displayed is correct, press the **ENTER** or **YES** button to return to the days of the week. If the start time is not correct, press the **NO** button. You will be prompted with "start hrs→XX←". Use the numeric keypad to enter the desired start hours (00 to 23) and press the **ENTER** button. You will be prompted with "start mins→XX←". Use the numeric keypad to enter the desired start minutes (00 to 59) and press the **ENTER** button. You will be prompted with "start secs→XX←". Use the numeric keypad to enter the desired start seconds (00 to 59) and press the **ENTER** button. The programmed start time will be displayed. If the start time displayed is correct, press the **ENTER** or **YES** button to return to the days of the week. Press the **EXIT** button twice to return to the Reset control menu.

### d. Monthly

To reset a point once a Month:

Use the **UP** (↑) or **DOWN** (↓) button to highlight **Monthly** and press the **ENTER** button. You will be prompted with "rst day →XX←". Use the numeric keypad to enter the desired day of the month on which to reset (00 to 31) and press the **ENTER** button. You will be prompted with "start XX:XX:XX".

If the start time displayed is correct, press the **ENTER** or **YES** button to return to the Auto reset setup menu. If the start time is not correct, press the **NO** button. You will be prompted with "start hrs→XX←". Use the numeric keypad to enter the desired start hours (00 to 23) and press the **ENTER** button. You will be prompted with "start mins→XX←". Use the numeric keypad to enter the desired start minutes (00 to 59) and press the **ENTER** button. You will be prompted with "start secs→XX←". Use the numeric keypad to enter the desired start seconds (00 to 59) and press the **ENTER** button. The programmed start time will be displayed. If the start time displayed is correct, press the **ENTER** or **YES** button to return to the Auto reset setup menu. Press the **EXIT** button to return to the Reset control menu.

#### 5.6.5.15.2 Event reset

The Event reset option allows Calculated Points to be programmed to reset upon some external Event via the optional digital inputs on the rear panel. When programming the Event reset, the Event number is the digital input number for that external Event (1, 2 or 3). Selecting 0 disables the Event reset.

To set the Event reset function:

From the Reset control menu use the **UP (↑)** or **DOWN (↓)** button to highlight **Event reset** and press the **ENTER** button. You will be prompted with “event? X”. Use the **UP (↑)** or **DOWN (↓)** button to select the desired Event input number (0, 1, 2 or 3) and press the **ENTER** button to return to the Reset control menu.

#### 5.6.5.15.3 Reset print

Printing the point reset data to the Alarm/Event data log at the time of the reset, or if enabled, to disk (see Section 5.7.2) can be toggled On (Yes) or Off (No) for each resettable point using the Reset print option.

To set the Reset print to Yes or No:

From the Reset control menu use the **UP (↑)** or **DOWN (↓)** button to highlight **Reset print** and press the **ENTER** button. Press the **YES** or **NO** button to select either **print=YES** (to activate Reset print) or **print=NO** (to disable Reset print) and then press the **ENTER** button to return to the Reset control menu.

#### 5.6.5.16 Time period

The Time period is the time base used to set the duration (time) of the moving window. The point average is set for this period of time (a maximum 1440 minutes of time is possible) and then the first scan is dropped off and a new scan is averaged in.

To program the Time period:

From the Point Setup menu use the **UP (↑)** or **DOWN (↓)** button to highlight **Time period** and press the **ENTER** button. You will be prompted with “minutes→XXXX←”. Use the numeric keypad to enter the desired time period (up to 1440 minutes, 24 hours) and press the **ENTER** button to return to the Point Setup menu.

#### 5.6.5.17 Gate control

The Gate control option can be turned On (Yes) or Off (No). If Gate control is turned On, a basepoint must be established. If Gate control is turned Off, this Point range can be used as a timer for calculations, etc.

To enable or disable Gate control:

From the Point Setup menu use the **UP (↑)** or **DOWN (↓)** button to highlight **Gate control** and press the **ENTER** button. Press the **YES** or **NO** button to select either **gate=YES** (to enable Gate control) or **gate=NO** (to disable Gate control) and then press the **ENTER** button. If “gate=NO” is selected, the display will return to the Point Setup menu. If “gate=YES” is selected, you will be prompted “base pt? X”. Use the **UP (↑)** or **DOWN (↓)** button to select the desired point character and then press the **ENTER** button to return to the Point Setup menu.

#### 5.6.5.18 Flowrate

This function allows different Flowrates to be set which can affect accuracy of the totals.

To set the Flowrate:

From the Point Setup menu use the **UP (↑)** or **DOWN (↓)** button to highlight **Flowrate** and press the **ENTER** button. Use the **UP (↑)** or **DOWN (↓)** button to select the desired flowrate: **flow= /sec**, **flow= /min**, **flow= /hr**, or **flow= /day** and press the **ENTER** button. Press the **EXIT** button to return to the Point Setup menu.

### 5.6.5.19 Low cutoff

This function allows the user to program a Low flow cutoff. If Totalization is not wanted below a predetermined flowrate, the Low cutoff can be set at that rate and Totalization will be shut off if the point level falls below the preset value.

To set the Low cutoff:

From the Point Setup menu use the **UP** (↑) or **DOWN** (↓) button to highlight **Low cutoff** and press the **ENTER** button. You will be prompted with “cut→XXX.XX←”. Use the numeric keypad to enter the desired Low cutoff value and press the **ENTER** button to return to the Point Setup menu.

### 5.6.5.20 Set cndtionl

The Set conditional option allows the user to program a set of conditions for a point. Up to 40 operators can be programmed in any one conditional statement. The available conditional operators are:

P1 to PF	are used to represent Points (Must be pre programmed)
K1 to KF	are used to represent Constants (Must be pre programmed)
)	RIGHT Parenthesis
	OR
&	AND
<	Less than
>	Greater than
=	Equal to
!=	Not equal to
<=	Less than or equal to
>=	Greater than or equal to
!	NOT
(	LEFT Parenthesis

To Set a conditional statement:

From the Point Setup menu use the **UP** (↑) or **DOWN** (↓) button to highlight **Set cndtionl** and press the **ENTER** button. Use the **UP** (↑) or **DOWN** (↓) button to scroll through the conditional operators until you reach the desired operator. Then use the **RIGHT** (→) button to move the cursor to the next position. Continue using the **UP** (↑) or **DOWN** (↓) button to select the operators and the **LEFT** (←) or **RIGHT** (→) button to move the cursor until the conditional statement is complete. Forty (40) positions are available for conditional operators, and the display will scroll to the left or right to allow entry. When the desired conditional statement is displayed, press the **ENTER** button to return to the Point Setup menu. The conditional statement is evaluated from left to right. Use parenthesis to change the order of evaluation. The result of any conditional statement evaluation is either TRUE or FALSE.

### 5.6.5.21 Timeout

The Timeout option sets a maximum time period between signal updates from the external source before flagging the point as invalid. The point is flagged invalid if no update is received within the specified timeout period. If the Timeout value is set to 0, the Timeout option is disabled.

To set a Timeout value:

From the Point Setup menu use the **UP** (↑) or **DOWN** (↓) button to highlight **Timeout** and press the **ENTER** button. You will be prompted with “seconds→XXXX←”. Use the numeric keypad to enter the desired Timeout value (up to 3600 seconds, 1 hour) and press the **ENTER** button to return to the Point Setup menu.

### 5.6.6 Linear Current/Voltage Point Types

The Recorder accepts five types of voltage linear inputs: 150mV, 1.25V, 2.5V, 12.5V and 25V and three types of linear current inputs: 4 to 20mA, 0 to 20mA and 10 to 50mA.

**NOTE:** The Dry contact Point Type is described in Section 5.6.7.

**Deciding Which Voltage Range to Use** - In deciding which of the voltage ranges to use, select the smallest range that will accommodate the full span of the input signal for the best resolution and accuracy of the Analog-to-Digital Converter (ADC).

**Current Inputs Voltage Shunt** - Current inputs are converted to voltage by means of an external 50 ohm shunt resistor supplied by the user. The following formula is used to determine the appropriate low and high end input voltage for non-standard current inputs:

**Ohms Law:**  $E = I * R$   
 E = Equivalent voltage inputs  
 I = Current in milliamps  
 R = Precision shunt resistance value

**Shunt Resistor Example** - The following example shows a low and high end input voltage for a 0 to 1mA input with a precision shunt resistance of 1000 ohms with the measurement done on the 1.25V range.

$E = 0 \times 1000 = 0\text{mV} = 0 \text{ V}$  (Low input)  
 $E = 1 \times 1000 = 1000\text{mV} = 1 \text{ V}$  (High input)

Using the Input and Output scaling, the user can program full scale ranges for the above input.

**Programming Parameters** - Once a point has been programmed as Linear and a voltage or current mode is selected, the user is presented with the following parameters:

Point tag	Section 5.6.5.1
Input scale	Section 5.6.5.2
Output scale	Section 5.6.5.3
Exc. Currents	Section 5.6.5.4
Filter	Section 5.6.5.6
Eng units	Section 5.6.5.9
Alarms	Section 5.6.5.10
Chart scale	Section 5.6.5.11
Output mode	Section 5.6.5.12

**NOTE:** Not all the above options will be available. It depends on the choice of input range.

### 5.6.7 Dry Contact Point Type

The Dry contact Point Type allows a point to be programmed to act like an open or closed contact. The input can be a set of potential free contacts. Logically an open contact is equal to 0 (zero) and a closed contact is equal to 1.

Once a point has been programmed as Linear-Dry contact the user is presented with the following parameters:

Point tag	Section 5.6.5.1
Eng units	Section 5.6.5.9
Alarms	Section 5.6.5.10
Chart scale	Section 5.6.5.11

### 5.6.8 Industrial Square Root Current/Voltage Point Types

The Recorder accepts five voltage square root extraction ranges: 150mV sqrt, 1.25 Volt sqrt, 2.5 Volt sqrt, 12.5 and 25 Volt sqrt and three types of linear current square root extraction ranges: 4 to 20mA sqrt, 0 to 20mA sqrt and 10 to 50mA sqrt.

This function is used for inputs which require the Industrial Square Root of the input signal (i.e. flow measurement). The system calculates the square root of the percentage of input scale and multiplies this value by the high end scale to produce the value of the point displayed.

In the following example, the input is 4 to 20mA and the scaling is such that 0 = Low End of Scale and 1000 = High End of Scale.

High End Scale = 1000 gallons per minute

Input Signal = 12mA or 50% of scale which is equal to 0.5

Square Root of 0.5 = 0.707

Actual value displayed is  $0.707 \times 1000 = 707$  GPM (with Decimal fix of 0)

Current input signals require that the user provide an external resistor.

**Programming Parameters** - Once a point has been programmed as Industrial Square Root and a voltage or current mode is selected, the user is presented with the following parameters:

Point tag	Section 5.6.5.1
Input scale	Section 5.6.5.2
Output scale	Section 5.6.5.3
Exc. Currents	Section 5.6.5.4
Filter	Section 5.6.5.6
Eng units	Section 5.6.5.9
Alarms	Section 5.6.5.10
Chart scale	Section 5.6.5.11
Output mode	Section 5.6.5.12

### 5.6.9 Logarithmic Linear Point Types

The Recorder accepts five types of linear voltage logarithmic ranges: 150mV log, 1.25 Volt log, 2.5 Volt log, 12.5 Volt log and 25 Volt log and three types of linear current logarithmic ranges: 4 to 20mA log, 0 to 20mA log and 10 to 50mA log.

**Programming Parameters** - Once a point has been programmed as Log linear and a voltage or current mode is selected, the user is presented with the following parameters:

Point tag	Section 5.6.5.1
Input scale	Section 5.6.5.2
Output scale	Section 5.6.5.3 (requires entry of low and high exponents)
Exc. Currents	Section 5.6.5.4
Filter	Section 5.6.5.6
Eng units	Section 5.6.5.9
Alarms	Section 5.6.5.10
Chart scale	Section 5.6.5.11
Output mode	Section 5.6.5.12

**Output Scale** - All Logarithmic linear current and voltage inputs must be assigned low and high output scale endpoints. The endpoints are the exponent values (the x in  $10^x$ ) between +25 to -25. When programming the Output scale, after selecting the desired number of places, you will be prompted with "lo exp→XXXX←". Use the numeric keypad to enter the desired low exponent value and press the **ENTER** button. You will be prompted with "hi exp→XXXX←". Use the numeric keypad to enter the desired high exponent value and press the **ENTER** button.

### 5.6.10 Thermocouple (T/C) Point Types

Several Thermocouple type points are available for selection. The choices are: J, K, T, E, R, S, B, C, N (Nicro), L and Ninimo.

**Programming Parameters** - Once a point has been programmed as a specific Thermocouple point type, the user is presented with the following parameters:

Point tag	Section 5.6.5.1
Decimal fix	Section 5.6.5.5
Filter	Section 5.6.5.6
Compensation	Section 5.6.5.7
Span/offset	Section 5.6.5.8
Eng units	Section 5.6.5.9
Alarms	Section 5.6.5.10
Chart scale	Section 5.6.5.11
Output mode	Section 5.6.5.12

### 5.6.11 Resistance Temperature Detector (RTD) Point Types

Several types of RTDs are available for selection. The choices are: 10Ω Cu, 100Ω PT 385, 100Ω PT 392, 200Ω PT 385, 200Ω PT 392, 120Ω ni, 100Ω ni or 1000Ω ni.

**Programming Parameters** - Once a point has been programmed as a specific RTD point type, the user is presented with the following parameters:

Point tag	Section 5.6.5.1
Decimal fix	Section 5.6.5.5
Filter	Section 5.6.5.6
Span/offset	Section 5.6.5.8
Eng units	Section 5.6.5.9
Alarms	Section 5.6.5.10
Chart scale	Section 5.6.5.11
Output mode	Section 5.6.5.12

### 5.6.12 Calculated Point Types

When programming Calculated Point Types, the Calculated Point Type menu will be displayed with the following options:

- Equation
- High peak
- Low peak
- High/Low difference
- Moving average
- Time average
- Gated timer
- Totalize



Calculations can be performed on current point values of a single point or a group of points if set in Equations. The calculations are performed after each scan of all measured points and the results are stored until the next point scan.

**NOTE:** Moving average can be set on channels A, B, C, D E, and F.

### 5.6.12.1 Equation

The Equation Calculated Point Type allows the user to program an equation to calculate a value of one or more points and/or constants.

**Operators Used for Equations** - Forty operators are allowed in any one equation programmed. If the equation does not compute, the display will read "bad operand". The following operators are available:

P1 to PF	are used to represent Points
K1 to KF	are used to represent Constants
)	is a RIGHT Parenthesis
+	is Add
-	is Subtract
*	is Multiply
/	is Divide
^	is Fractional
**	is Raise to the Power ( $X^y$ )
Sq	is Square Root
Ln	is Natural Logarithm
Lg	is Base Ten Logarithm
Ex	is Exponentiation ( $e^x$ )
(	is a LEFT Parenthesis

**Programming Parameters** - Once a point has been programmed as a Calculated-Equation Point Type, the user is presented with the following parameters:

Point tag	Section 5.6.5.1
Decimal fix	Section 5.6.5.5
Set equation	Section 5.6.5.13
Eng units	Section 5.6.5.9
Alarms	Section 5.6.5.10
Chart scale	Section 5.6.5.11
Output mode	Section 5.6.5.12

### 5.6.12.2 High (Hi) peak

Hi peak Calculated Point Types keep track of the highest data of a given point. This data is stored until some form of reset occurs. When the data is reset, the Hi peak point data is printed on the chart / Alarm log along with the current time and the time the peak value occurred if the Reset print option is enabled.

**Programming Parameters** - Once a point has been programmed as a Calculated-Hi peak Point Type, the user is presented with the following parameters:

Point tag	Section 5.6.5.1
Decimal fix	Section 5.6.5.5
Basepoint	Section 5.6.5.14
Eng units	Section 5.6.5.9
Reset contrl	Section 5.6.5.15
Alarms	Section 5.6.5.10
Chart scale	Section 5.6.5.11



**NOTE:** When Hi peak, Lo peak or Time average Calculated point types are reset, the new value will be the current Basepoint value at the time of reset.

### 5.6.12.3 Low (Lo) peak

Lo peak Calculated Point Types keep track of the lowest data of a given point. This data is stored until some form of reset occurs. When the data is reset, the Lo peak point data is printed on the chart / Alarm log along with the current time and the time the peak value occurred if the Reset print option is enabled.

**Programming Parameters** - Once a point has been programmed as a Calculated-Lo peak Point Type, the user is presented with the following parameters:

Point tag	Section 5.6.5.1
Decimal fix	Section 5.6.5.5
Basepoint	Section 5.6.5.14
Eng units	Section 5.6.5.9
Reset contrl	Section 5.6.5.15
Alarms	Section 5.6.5.10
Chart scale	Section 5.6.5.11

### 5.6.12.4 High/Low Difference (Hilo diff)

This Calculated Point Type takes the difference between the lowest and highest values in a group of points. A First point number is assigned and a Last point number is assigned. The difference is taken from those points inclusive. This point must be outside of the group of points.

**Programming Parameters** - Once a point has been programmed as a Calculated-Hilo difference Point Type, the user is presented with the following parameters:

Point Tag	Section 5.6.5.1
Decimal fix	Section 5.6.5.5
Basepoints	Section 5.6.5.14 (Pick First and Last Basepoints)
Eng units	Section 5.6.5.9
Alarms	Section 5.6.5.10
Chart ccale	Section 5.6.5.11

### 5.6.12.5 Moving average (avg)

A Calculated Moving average point calculates the continuous average of the measured or processed value of a selected point based on the Time period of the moving window. The result is the weighted average of the present reading and the previous average value. Therefore, this type of point can be used to smooth out noisy or erratic signals and to attenuate the effects of sudden transitions. **Calculated Moving average points are only programmable for point numbers A through F.**

**Programming Parameters** - Once a point has been programmed as a Calculated-Moving average point type, the user is presented with the following parameters:

Point tag	Section 5.6.5.1
Decimal fix	Section 5.6.5.5
Basepoint	Section 5.6.5.14
Time period	Section 5.6.5.16
Eng units	Section 5.6.5.9
Alarms	Section 5.6.5.10
Chart scale	Section 5.6.5.11

### 5.6.12.6 Time Average (avg)

A Calculated Time average point calculates the continuous average of the measured or processed value of a selected point. The result is the weighted average of the present reading and the previous average value. Therefore, this type of point can be used to smooth out noisy or erratic signals and to attenuate the effects of sudden transitions.

**Programming Parameters** - Once a point has been programmed as a Calculated-Time average Point Type, the user is presented with the following parameters:

Point tag	Section 5.6.5.1
Decimal fix	Section 5.6.5.5
Basepoint	Section 5.6.5.14
Eng units	Section 5.6.5.9
Reset contrl	Section 5.6.5.15
Alarms	Section 5.6.5.10
Chart scale	Section 5.6.5.11

### 5.6.12.7 Gated timer

The Gated timer Calculated point type allows a timer (measuring in seconds) to be controlled by a 'gate' from a logic point. For example, if a point is measuring temperature and you wanted to know the total amount of time the temperature measured by this point is above or below a certain level, a Conditional point can be programmed to be TRUE only when the temperature is above or below a set level. A Gated timer point can then be programmed to be turned ON only when the Conditional point is in the TRUE state. The Gated timer point will then only be timing when the temperature is above or below a set level. The timer will continue to accumulate time (in seconds) each time it is turned on. The Gated timer point can be reset at programmable time intervals and alarms can be set to alarm if the timer total goes above a programmed time interval in seconds.

**Programming Parameters** - Once a point has been programmed as a Calculated-Gated timer Point Type, the user is presented with the following parameters:

Point tag	Section 5.6.5.1
Gate control	Section 5.6.5.17
Eng units	Section 5.6.5.9
Reset contrl	Section 5.6.5.15
Alarms	Section 5.6.5.10
Chart scale	Section 5.6.5.11

### 5.6.12.8 Totalize

The Totalize calculation keeps a running total of the value of a point sampled at a programmed rate. This will continue until the programmed reset interval time is reached at which time the value is logged on the Alarm/Event log window (if Reset print is enabled), is reset to zero, and the totalization calculation begins again. However, a Low flow cutoff provision prevents totalization on flowrates that meet or fall below the cutoff point. The data will also be recorded to disk if Alarm/Event logging is enabled. **The Totals are non-volatile for channels A through C unless the Auto reset option is active.**

**Programming Parameters** - Once a point has been programmed as a Calculated-Totalize Point Type, the user is presented with the following parameters:

Point tag	Section 5.6.5.1
Decimal fix	Section 5.6.5.5
Basepoint	Section 5.6.5.14
Flowrate	Section 5.6.5.18
Eng units	Section 5.6.5.9
Reset contrl	Section 5.6.5.15
Low cutoff	Section 5.6.5.19
Alarms	Section 5.6.5.10
Chart scale	Section 5.6.5.11

### 5.6.13 Conditional Point Types

Conditional Point Types are used when the user needs to set a list of operating conditions for a point.

**Operators Used for Setting Conditions** - Forty operators are allowed in any one formula programmed. If the conditions equation does not compute, the display will read "bad operand". The following operators are available:

P1 to PF	are used to represent Points (Must be pre programmed)
K1 to KF	are used to represent Constants (Must be pre programmed)
)	RIGHT Parenthesis
	OR
&	AND
<	Less than
>	Greater than
=	Equal to
!=	Not equal to
<=	Less than or equal to
>=	Greater than or equal to
!	NOT
(	LEFT Parenthesis

**Programming Parameters** - Once a point has been programmed as a Conditional Point Type, the user is presented with the following parameters:

Point tag	Section 5.6.5.1
Set cndtionl	Section 5.6.5.20
Eng units	Section 5.6.5.9
Alarms	Section 5.6.5.10
Chart scale	Section 5.6.5.11

### 5.6.14 External Point Types

External point types use data sent via the Com port to the Recorder for trending or other uses.

**Programming Parameters** - Once a point has been programmed as an External point type, the user is presented with the following parameters:

Point tag	Section 5.6.5.1
Input scale	Section 5.6.5.2
Output scale	Section 5.6.5.3
Timeout	Section 5.6.5.21
Eng units	Section 5.6.5.9
Alarms	Section 5.6.5.10
Chart scale	Section 5.6.5.11

## 5.7 Record Setup

The Record Setup menu option allows the user to program several items dealing with the recording of data to either a floppy disk or CompactFlash™ card. Some of the options include: choosing what to record, how it's recorded, and the filename it will be saved to; setting up alarm points to stop or start recording; and setting the full threshold to alarm the fact that the disk/card is getting full. Disks/cards can be formatted and configuration files can be saved or loaded from the Record Setup menu.

To program the Record Setup options:

From the Program menu use the **UP (↑)** or **DOWN (↓)** button to highlight **Record Setup** and then press the **ENTER** button. The Record Setup menu will be displayed as shown in Figure 5-8. Use the **UP (↑)** or **DOWN (↓)** button to select the option you wish to program and then press the **ENTER** button. The options are described in the following sections.

**NOTE:** The Record Setup Menu options **CANNOT** be accessed while the unit is recording. **Use the Record On/Off option in the FUNCTION Menu to stop the unit recording prior to attempting to access this menu.**

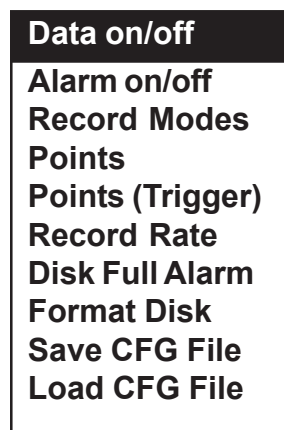

**Figure 5-8**  
**Record Setup Menu**

### 5.7.1 Data on/off

This option enables the user to enable or disable the recording of point data to disk/card.

To enable or disable point data recording:

From the Record Setup menu use the **UP (↑)** or **DOWN (↓)** button to highlight **Data on/off** and press the **ENTER** button. Press the **YES** or **NO** button to select either **record data=YES** (to enable data recording) or **record data=NO** (to disable data recording) and then press the **ENTER** button to return to the Record Setup menu. If you enable recording data and no points are turned on, you will get an error message.

**NOTE:** **The actual recording is turned on or off in the FUNCTION menu (accessed from the Main Button Bar) under the Record On/Off menu option. Refer to Section 4.2.3.1.**

**NOTE:** Floppy Disk models - Use only formatted 1.44 Meg Floppy disks (High Density) and ensure they are not write protected. The disks can be formatted using the Format Disk menu option (see Section 5.7.8).

## 5.7.2 Alarm on/off

This option enables the user to enable or disable the recording of Alarm and Event information to disk/card.

To enable or disable the recording of Alarm/Event information:

From the Record Setup menu use the **UP** (↑) or **DOWN** (↓) button to highlight **Alarm on/off** and press the **ENTER** button. Press the **YES** or **NO** button to select either **record alarms=YES** (to enable Alarm/Event recording) or **record alarms=NO** (to disable Alarm/Event recording) and then press the **ENTER** button to return to the Record Setup menu. No data will actually be stored until the Recorder is set to Record On under the Record On/Off menu option in the FUNCtion Menu.

## 5.7.3 Record Modes

There are two Record Modes that can be set: Fill Mode and Data Mode. The Fill Mode determines whether files are to be recorded to fill the disk and stop, or recycle, deleting the oldest data and replacing it with new. The Data Mode options determine whether data will be averaged over the record interval or whether the latest data, peak value or valley value is stored. If you are using one of the intrinsic functions of the unit, for example peak values, you must set the sample mode to instantaneous or you will average your peaks if you have a slow sample storage rate.

To set the Record Modes:

From the Record Setup menu, use the **UP** (↑) or **DOWN** (↓) button to highlight **Record Modes** and press the **ENTER** button. The Record Modes Setup menu will display three options: **Fill Mode**, **Data Mode All** and **Data Mode Indiv**. These options are described in the following sections.

### 5.7.3.1 Fill Mode

The Fill Mode determines how the data fills the disk/card. There are two Fill Mode options available: Fill to End and Cycle Data.

To set the Fill Mode:

From the Record Modes Setup menu use the **UP** (↑) or **DOWN** (↓) button to highlight **Fill Mode** and press **ENTER**. The current mode will appear highlighted. Use the **UP** (↑) or **DOWN** (↓) button to select either **Fill to End** or **Cycle Data** as desired and press the **ENTER** button to activate. Press the **EXIT** button to return to the Record Modes Setup menu.

#### 5.7.3.1.1 Fill to End

The Fill to End option sets the unit to record to disk/card until the disk/card is full and then it will shut the recording off.

#### 5.7.3.1.2 Cycle Data

The Cycle Data option sets the unit to continue recording to disk/card until the disk/card is almost full and then it will start to write over the earliest data a block at a time (about 500 samples at a time). The disk/card will always contain the most current data, and the oldest data will be lost. All points respect the integrity of data for other points, each point will only replace it's own data.

**NOTE:** Set the Disk Full Alarm threshold to 100% when running in the cyclic mode to prevent the Disk Full Alarm from activating (see Section 5.7.7.1).

### 5.7.3.2 Data Mode All

There are four Data Modes to choose from: Instantaneous, Average, Peak, and Valley. The Data Mode can be applied to all points simultaneously (Data Mode All) or it can be set independently for each individual point (Data Mode Indiv.).

To program a Data Mode for all points:

From the Record Modes Setup menu use the **UP (↑)** or **DOWN (↓)** button to highlight **Data Mode All** and press the **ENTER** button. The current Data Mode will appear highlighted. To change the Data Mode, use the **UP (↑)** or **DOWN (↓)** button to select **Instantaneous**, **Average**, **Peak**, or **Valley** as desired and press the **ENTER** button to activate. Press the **EXIT** button to return to the Record Modes Setup menu.

#### 5.7.3.2.1 Instantaneous

The Instantaneous mode stores only the latest sample to the disk/card and is used if you have one of the special functions enabled, such as peak reading or moving average that does not need to be averaged.

#### 5.7.3.2.2 Average

The Average mode will average all input data sampled at 8 times per second to the Record rate being recorded. Thus, if data is being stored to disk/card once every minute (60 seconds), 480 samples will be averaged.

#### 5.7.3.2.3 Peak

Peak mode will record the peak or maximum value within the selected Record rate.

#### 5.7.3.2.4 Valley

Valley mode will record the valley or minimum value within the selected Record rate.

### 5.7.3.3 Data Mode Indiv.

The user has the option to set the Data Mode for each channel individually.

To program a Data Mode individually for each point:

From the Record Modes Setup menu use the **UP (↑)** or **DOWN (↓)** button to highlight **Data Mode Indiv.** and press the **ENTER** button. You will be prompted with "point? X". Use the keypad to select relevant point and press the **ENTER** button. The current Data Mode will appear highlighted. To change the Data Mode, use the **UP (↑)** or **DOWN (↓)** button to select **Instantaneous**, **Average**, **Peak**, or **Valley** as desired and press the **ENTER** button to activate. Press the **EXIT** button to return to the Record Modes Setup menu. Repeat this process for each point you want to set.

## 5.7.4 Points

The user may select which of the fifteen available points are to be recorded to disk/card. Any or all points may be recorded, however the recording time available on the disk is divided among the number of points being recorded. Ensure that points you do not wish to record, or that have no data attached, are not turned on to record.

To turn the points on or off:

From the Record Setup menu, use the **UP (↑)** or **DOWN (↓)** button to highlight **Points** press the **ENTER** button. The display will read "point 1=yes" or "point 1=no". Use the **UP (↑)** or **DOWN (↓)** button to select the point you wish to turn on or off. Press the **YES** button to record the point or the **NO** button to turn the point off and not record. The next point will then be displayed. Once all points have been set to yes or no, press the **ENTER** button to return to the Record Setup menu.

### 5.7.5 Points (Trigger)

The user may select which of the fifteen available points are to be used to trigger the Record Mode on or off. Any or all points may be used to trigger recording. When activated, any alarm condition for the point in question will start the unit recording, provided the unit is armed to trigger. Refer to Section 4.2.3.1.3. The unit will record as long as the Alarm is True.

To enable points to trigger recording:

From the Record Setup menu, use the **UP (↑)** or **DOWN (↓)** button to highlight **Points (Trigger)** press the **ENTER** button. The display will read “point 1=yes” or “point 1=no”. Use the **UP (↑)** or **DOWN (↓)** button to select the point you wish to turn on or off. Press the **YES** button to activate the point to trigger recording or the **NO** button to disable the point from triggering recording. The next point will be displayed. Once all points have been set to yes or no, press the **ENTER** button to return to the Record Setup menu.

### 5.7.6 Record Rate

The user can select the rate at which data is stored to disk independently to the rate at which it is displayed on the chart. The Record Rate can be set for all channels at once (All Rates) or it can be set for each channel individually (Individual Rate). The Record Rate can be set from the fastest rate of 8 times per second to the slowest rate of once every 600 seconds or once every ten minutes. The rate you choose is dependent on how dynamic the process that you are measuring is. If you are recording temperature which varies slowly, you can maximize the amount of data that is stored on the disk by keeping the Record Rate slow. If you are measuring variables that change rapidly, you may need to set the Record Rate at once per second. Thus if you have one channel that is recording a rapidly changing input and one that is recording an input that changes slowly, you can optimize the Record Rate for each.

There are two Record Rate options for each channel or point: a low rate and a high rate. The default rate is set in the **FUNCTION** menu under the Record speed option. The Record Rate can also be changed by an external event if the digital I/O option is fitted. Refer to Section 5.9.2. External speed change is enabled using the Autorate option.

To set the Record Rate:

From the Record Setup menu, use the **UP (↑)** or **DOWN (↓)** button to highlight **Record Rate** and press the **ENTER** button. The Record Rate menu will be displayed with three options: **All Rates**, **Individual Rate**, and **Autorate**. These options are described in the following sections.

#### 5.7.6.1 All Rates

To set the Record Rates for all channels at once:

From the Record Rate menu use the **UP (↑)** or **DOWN (↓)** button to highlight **All Rates** and press the **ENTER** button. You will be prompted with “secs(lo)→XXX←” where XXX is the current Low Record Rate in seconds. Use the numeric keypad to enter the desired Low Record Rate from 0 to a maximum of 600 seconds, and then press the **ENTER** button. You will be prompted with “secs(hi)→XXX←” where XXX is the current High Record Rate in seconds. Use the numeric keypad to enter the desired High Record Rate from 0 to a maximum of 600 seconds, and then press the **ENTER** button to return to the Record Rate menu. Press the **EXIT** button at any time to return to the Record Rate menu without altering the settings.

**NOTE:** To set the Record Rate to 8 times per second, set the rate to **0** seconds.

**NOTE:** Although the Record Rates are shown as Low and High, the Low rate can be set to be faster than the High rate. The Low and High rates are mutually exclusive and are set in the **FUNCTION**, Record speed menu option. The current Record Rate (Low or High) is indicated in the Disk Status Window: the Low rate is indicated by **REC ↓** and the High rate is indicated by **REC ↑**. If you do not plan to use the change Record Rate option, set both Record Rates to the same value.



### 5.7.6.2 Individual Rates

To set the individual Record Rates per channel:

From the Record Rate menu use the **UP** (↑) or **DOWN** (↓) button to highlight **Individual Rate** and press the **ENTER** button. You will be presented with a point selection keypad that enables the selection of the specific point to be programmed. Use the keypad to enter the desired point number and press the **ENTER** button. You will be prompted with “secs(lo)→XXX←” where XXX is the current low sampling rate in seconds. Use the numeric keypad to enter the desired Record Rate (from 0 to a maximum of 600 seconds) and then press the **ENTER** button. You will be prompted with “secs(hi)→XXX←” where XXX is the current high sampling rate in seconds. Use the numeric keypad to enter the desired Record Rate (from 0 to a maximum of 600 seconds) and then press the **ENTER** button to return to the Record Rate menu. Repeat the above procedure for each point to be programmed. Press the **EXIT** button at any time to return to the Record Rate menu without altering the settings.

### 5.7.6.3 Autorate

The Autorate option enables the Record Rate to be changed on an Alarm event. If the digital I/O option is fitted, the switch inputs can be set to change the Record speed. An active input selects the High speed, and an inactive input selects the Low speed. The inputs can be overridden in the FUNcTION menu until a change of input state takes place.

The logic for external Record Rate change is as follows:

SWITCH	RECORD RATE
lo to hi	high
hi to lo	low

To enable Autorate change:

From the Record Rate menu use the **UP** (↑) or **DOWN** (↓) button to highlight **Autorate** and press the **ENTER** button. The display will read “autorate=NO” or “autorate=YES”. Press the **YES** button to enable or the **NO** button to disable the Autorate change on Alarm option and then press the **ENTER** button to return to the Record Rate menu.

## 5.7.7 Disk Full Alarm

The Disk Full Alarm option allows the user to set a threshold to indicate when the disk/card is full. The indication is via a pop-up window on the screen, or if the relay option is fitted, via a contact closure. The threshold limit may be set by the user to any value between 1 and 100 percent. Setting the limit to 100% prevents the Disk Full Alarm from activating.

To set the Disk Full Alarm options:

From the Record Setup menu, use the **UP** (↑) or **DOWN** (↓) button to highlight **Disk Full Alarm** and press the **ENTER** button. The Disk Full Alarm Setup menu will be displayed with three options: **Full setpoint**, **Full contact #**, and **Rec. contact #**.

### 5.7.7.1 Disk Full Setpoint (Full setpoint)

The Full setpoint option sets the Disk Full Alarm threshold.

To change the Disk Full Alarm threshold:

From the Disk Full Alarm Setup menu use the **UP** (↑) or **DOWN** (↓) button to highlight **Full setpoint** and press the **ENTER** button. Use the numeric keypad to enter the percentage point (1 to 100 percent) at which the disk/card will indicate nearly full and press the **ENTER** button to return to the Disk Full Alarm Setup menu.



### 5.7.7.2 Disk Full Alarm Output (Full contact #)

If the relay option is fitted, the Disk Full Alarm can trigger a contact closure.

To set the Disk Full Alarm to trigger a contact closure:

From the Disk Full Alarm Setup menu use the **UP (↑)** or **DOWN (↓)** button to highlight **Full contact #** and press the **ENTER** button. You will be prompted with "Full contact #? X". Use the **UP (↑)** or **DOWN (↓)** button to select a relay contact number, 1 through 6, or 0 for no contact closure. Then press the **ENTER** button to return to the Disk Full Alarm Setup menu.

**NOTE:** If the relay output option is installed, the contact selected will close when the Disk Full Alarm threshold is reached. Once a contact has been selected, all disk errors (e.g. Read/write, File not found etc.) will also cause the same contact to close.

### 5.7.7.3 Record Status Alarm Output (Rec. contact #)

If the relay option is fitted, it is possible to monitor the record status via a contact closure. When the unit is recording, it closes the selected contact. When the unit is not recording, the selected contact is open.

To monitor the record status via a contact closure:

From the Disk Full Alarm Setup menu use the **UP (↑)** or **DOWN (↓)** button to highlight **Rec. contact #** and press the **ENTER** button. You will be prompted with "Rec. contact #? X". Use the **UP (↑)** or **DOWN (↓)** button to select a relay contact number, 1 through 6, or 0 for no contact closure. Then press the **ENTER** button to return to the Disk Full Alarm Setup menu.

## 5.7.8 Format Disk

The floppy disk or CompactFlash™ card must first be formatted before being used. This can be done in the unit, or on any IBM compatible PC running MSDOS. The disks are formatted in MSDOS compatible format. Note that only 1.44 Meg (High Density) 3½ inch floppy disks can be used.

To format a disk/card:

First ensure that the disk/card is not write protected. The plastic slide in one corner of the floppy disk must be in a position such that it exposes the hole in the plastic cover. The CompactFlash™ card may have a tiny slide switch on the back end which will be marked as to which way is write protected. Open the door below the LCD screen to expose the drive. Insert a floppy disk, label side up with the metal toward the drive opening. Insert a CompactFlash™ card with the arrow facing up and towards the drive opening. Insure the disk/card is pushed fully into the drive; it will be pulled in and down.

Once the disk/card has been inserted into the drive, from the Record Setup menu use the **UP (↑)** or **DOWN (↓)** button to highlight **Format Disk** and press the **ENTER** button. A pop up window will display "format=NO\*". Press the **YES** button to change the display to read "format=YES?" and then press the **ENTER** button to start formatting. The light on the drive will come on while the disk/card is being formatted. The Disk Status Window will indicate **FORMAT** while the disk/card is formatting. Once formatting has been completed a window will pop up to announce "Format Complete" or it will indicate any error if the disk could not be formatted. Press the **OK?** button to accept. You will be returned to the Record Setup menu.

## 5.7.9 Save Configuration (CFG) File

This function allows the user to save the unit configuration to the disk/card for later retrieval or archiving. This saves the entire user configuration database, which is usually stored in nonvolatile memory. It is recommended that the user perform this function after fully setting up the unit for the first time. This allows the user to return at any stage to a known, good configuration setup or may be used to transfer this setup to other machines. The file will be saved with the current filename as set by the user (see Section 5.7.11). Any existing configuration file on the disk with the same name will be overwritten.

To save the configuration file:

Ensure that a formatted disk/card is in the drive. From the Record Setup menu, use the **UP (↑)** or **DOWN (↓)** button to highlight **Save CFG File** press the **ENTER** button. A pop up window will display “save config=NO\*”. Press the **YES** button to change the display to read “save config=YES?” and then press the **ENTER** button to save the configuration with the current filename to the disk/card. The Disk Status Window will show “SAVE CFG” and a window will pop up when the configuration has been saved to indicate “Configuration Saved”. Press the **OK?** button to return to the Record Setup menu.

### 5.7.10 Load Configuration (CFG) File

It is possible to load a previously saved configuration file or a configuration file that has been generated at a remote PC, to automatically setup the unit. There may be more than one named configuration file on the disk enabling the user to quickly customize set up for various applications.

To load an existing configuration:

From the Record Setup menu, use the **UP (↑)** or **DOWN (↓)** button to highlight **Load CFG File** and press the **ENTER** button. A pop up window will display “load config=NO\*”. Press the **YES** button to change the display to read “load config=YES?” and then press the **ENTER** button. The unit will look on the disk/card for any configuration files which will be displayed in the File Directory. If more than one file exists on the disk, the directory will list them one above the other, with the current file to be loaded indicated by the arrows alongside it as shown below. If no configuration file is found the unit will indicate “No Files Found”.

File Directory	
Configurations:	
→ OLDFILE	.CFG←(Date)(Time)(Size)
NEWFILE	.CFG

If more than one configuration file exists, use the **UP (↑)** or **DOWN (↓)** button to select the desired file and press the **ENTER** button. If there are more files on the disk/card than what will show on the screen, the list will scroll down with the arrows. The unit will load the selected configuration file from the disk/card and the Disk Status Window will show “LOAD CFG”. If the load is successful, a window will pop up indicating “Configuration Loaded”. Press the **OK?** button. At this point the unit will automatically reset and begin with the newly loaded parameters.

**Note:** Once the configuration load has been initiated, the unit will automatically load and restart. Be sure you select the correct configuration file. It is advisable to save your current configuration before loading a new one. Use a new disk/card or different filename to save the old configuration.

 **The passcodes and calibration constants are NOT loaded from the configuration file to maintain access and calibration integrity.**

### 5.7.11 Filename

The user can enter a filename to uniquely identify the recordings being made. The filename can be any valid DOS filename up to a maximum of 8 characters, e.g. BATCH1 or SAMPLE5. This filename is applied to all pen files, the alarm file and the configuration file. Thus if the name “BATCH1” is entered, the file for pen 1 will be saved as BATCH1.DT1, the file for pen 2 will be saved as BATCH1.DT2 and so on. The alarm file will be saved as BATCH1.ALM and the configuration file will be saved as BATCH1.CFG. A disk/card can hold several files with different names. For example, you may run three batches and name the files for each batch (e.g. BATCH1, BATCH2 and BATCH3) all on the same disc.

To enter a Filename:

From the Record Setup menu, use the **UP (↑)** or **DOWN (↓)** button to highlight **Filename** and press the **ENTER** button. You will be presented with a display that shows "→FILENAME←" where FILENAME is the current filename. Use the alphanumeric keypad to enter up to 8 characters for a new filename. Note that the filename cannot contain spaces and must consist of the letters A through Z, the numbers 0 through 9 or the characters #, %, &, (, ), @. Do not try to type DOS extensions. Once you have entered the filename you want, press the **ENTER** button to save it and return to the Record Setup menu.

**NOTE:** The default filename is the version with an "@" sign used as a decimal point, e.g. VM2@1A for Version 2.1a.

## 5.8 Measurement

The Measurement menu option allows the user to program items directly affecting the measurement of Inputs.

To program the Measurement options:

From the Program menu use the **UP (↑)** or **DOWN (↓)** button to highlight **Measurement** and then press the **ENTER** button. The Measurement menu will be displayed with two options: **Span&offset** and **Demo Mode**. Use the **UP (↑)** or **DOWN (↓)** button to select the option you wish to program and then press the **ENTER** button. The options are described in the following sections.

### 5.8.1 Span & Offset

The Span & Offset option allows the user to turn Span and Offset On or Off for RTD and Thermocouple point types. This function enables Span and Offset compensation to allow for correction of known inaccuracies in RTDs and Thermocouples.

To enable or disable Span & Offset:

From the Measurement menu, use the **UP (↑)** or **DOWN (↓)** button to highlight **Span&offset** and press the **ENTER** button. The display will read "spnofs=YES\*" or "spnofs=NO\*". Press the **YES** button to enable Span & Offset or the **NO** button to disable Span & Offset and then press the **ENTER** button to return to the Measurement menu.

If enabled, a Span&offset menu option will be displayed in the Point setup menu to adjust the Span and Offset compensation values for Thermocouple and RTD point types.

### 5.8.2 Demo Mode

The Demo Mode option allows the user to put the Recorder in the Demo Mode of operation. In the Demo Mode, direct inputs are ignored and calculated points use internally generated waveforms.

The Demo Mode is suited to the 1 volt scale. It is advisable to set up a sample Demo Mode and save the configuration to disk/card. Then this configuration can be loaded anytime the Demo Mode is required.

To turn the Demo Mode On or Off:

From the Measurement menu, use the **UP (↑)** or **DOWN (↓)** button to highlight **Demo Mode** and press the **ENTER** button. The display will read "Demo mode=YES\*" or "Demo mode=NO\*". Press the **YES** button to turn the Demo Mode On or the **NO** button to turn the Demo Mode Off and then press the **ENTER** button to return to the Measurement menu.

**NOTE:** In the Demo Mode of operation, the Recorder ignores all direct inputs and uses an internal generator for external or calculated points. Powering the unit off loses the Demo Mode.

## 5.9 Digital I/O

The Digital I/O (Optocoupled Inputs, Relay Outputs) option must be fitted in order for the options in this section to work. If you do not have the option fitted you should ensure that all inputs are programmed off.

The Digital I/O menu option allows the user to select what type of signal opens the output contacts and what function the input signals will perform. The user can also program custom event messages.

To program the Digital I/O options:

From the Program menu use the **UP (↑)** or **DOWN (↓)** button to highlight **Digital I/O** and then press the **ENTER** button. The Digital I/O menu will be displayed with three options: **Contact outs**, **Switches in**, and **Event msgs**. Use the **UP (↑)** or **DOWN (↓)** button to select the option you wish to program and then press the **ENTER** button. The options are described in the following sections.

### 5.9.1 Contact outs

The Contact outs option allows the user to select what type of signal controls the Contact Out relays.

To set the Contact Out options:

From the Digital I/O menu, use the **UP (↑)** or **DOWN (↓)** button to highlight **Contact outs** and press the **ENTER** button. The Contact outs menu will be displayed with four menu options: **Alarms clear**, **ACK key**, **Failsafe**, and **Reflash**. These options are described in the following sections.

#### 5.9.1.1 Alarms clear

The Alarms clear option opens the Contacts Out when the Alarms are cleared (default), else they remain latched.

To turn the Alarms clear option on or off:

From the Contact outs menu use the **UP (↑)** or **DOWN (↓)** button to highlight **Alarms clear** and press the **ENTER** button. The display will read either "opn clr=YES\*" (default) or "opn clr=NO\*". Press the **YES** button to select whether the Contact outs should open when the Alarms are cleared or the **NO** button to not open. When the desired selection is displayed, press the **ENTER** button to return to the Contact outs menu.

**NOTE:** To make the outputs latching, set Alarms clear to NO and ACK key to YES.

#### 5.9.1.2 ACK key

The ACK key option opens the Contacts Out when the ACKnowledge key is pressed.

To turn the ACK key option on or off:

From the Contact outs menu use the **UP (↑)** or **DOWN (↓)** button to highlight **ACK key** and press the **ENTER** button. The display will read either "opn ack=YES\*" or "opn ack=NO\*". Press the **YES** button to select whether the Contact outs should open when the ACK key is pressed or the **NO** button to not open. When the desired selection is displayed, press the **ENTER** button to return to the Contact outs menu.

**NOTE:** The ACK button position, top left corner of the screen is always active, so even though the ACK button is not blinking, the contacts can still be reset by pressing this area of the screen.

#### 5.9.1.3 Failsafe

The Failsafe option allows the Contacts Out to function as Failsafe Contacts. This reverses the logic so a contact which is normally OPEN will be energized. The Failsafe will drop out in the event of a power failure and indicate an alarm.

To turn the Failsafe option on or off:

From the Contact outs menu use the **UP (↑)** or **DOWN (↓)** button to highlight **Failsafe** and press the **ENTER** button. The display will read either "flsafe=YES\*" or "flsafe=NO\*". Press the **YES** button to select whether the Contact outs should Failsafe or the **NO** button to not Failsafe. When the desired selection is displayed, press the **ENTER** button to return to the Contact outs menu.

#### 5.9.1.4 Reflash

The Reflash option programs the Contacts Out to momentarily open and reclose each time an additional alarm is acquired, which is programmed to close the contacts.

To turn the Reflash option on or off:

From the Contact outs menu use the **UP (↑)** or **DOWN (↓)** button to highlight **Reflash** and press the **ENTER** button. The display will read either "reflash=YES\*" or "reflash=NO\*". Press the **YES** button to enable the Reflash option or the **NO** button to disable the Reflash option. When the desired selection is displayed, press the **ENTER** button to return to the Contact outs menu.

### 5.9.2 Switches in

The Switches in option allows the user to select a function for each of the three switches to activate. Any one of the following functions may be assigned to each switch: Event, Chart speed, Record on/off, Alarm acknowledgment, Scale set or Record Rate.

To set the Switch input options:

From the Digital I/O menu, use the **UP (↑)** or **DOWN (↓)** button to highlight **Switches in** and press the **ENTER** button. Use the **UP (↑)** or **DOWN (↓)** button to select the switch number (1, 2 or 3) to be programmed and then press the **ENTER** button. The Switches in menu will be displayed with four six options: **Event**, **Chart speed**, **Rec on/off**, **Alarm ack**, **Scale set** and **Rec Rate**. These options are mutually exclusive, and the highlighted option is active. The options are described in the following sections.

#### 5.9.2.1 Event

The Event option allows external inputs to be used to trigger an Event or reset a resettable point type. An input switch to be used to log an Event to the Alarm/Event data log, or if enabled in the FUNCtion-Record On/Off-Trigger menu option, to the disk/card.

The user can program Event messages for switch open (inactive) and switch closed (active). The Event messages are printed on the Alarm screen and if enabled, are recorded to disk/card. Refer to Section 5.9.3.

To set Switch input option to Event:

From the Switch in menu use the **UP (↑)** or **DOWN (↓)** button to select **Event** and press the **ENTER** button. Press the **EXIT** button to return to the Switch selection menu.

#### 5.9.2.2 Chart speed

The Chart speed option allows external inputs to be used to alter the Chart speed (on the graphics screen). The Chart speeds are set in the Chart/Pens, Speed menu.

There are two speed settings: High and Low. If the switch is open (inactive), the Low speed setting is selected. If the switch is closed (active), the High speed setting is active. This option works in conjunction with the selection in the FUNCtion, Chart speed menu option.

To set Switch input option to Chart speed:

From the Switch in menu use the **UP (↑)** or **DOWN (↓)** button to select **Chart speed** and press the **ENTER** button. Press the **EXIT** button to return to the Switch selection menu.

### 5.9.2.3 Record on/off

The Record on/off option allows the external inputs to be used to stop and start the recording to disk/card. If the switch is open (inactive), the recording is stopped. If the switch is closed (active), the recording is started. This option works in conjunction with the FUNcTion-Record On/Off menu options to start or stop recording. The last operation is current - that is if an external event started the recording, then the user used the menu to stop recording. The recording remains stopped until the external event is reasserted (in this case inactive then active again to restart).

To set Switch input option to Record on/off:

From the Switches in menu use the **UP (↑)** or **DOWN (↓)** button to select **Rec on/off** and press the **ENTER** button. Press the **EXIT** button to return to the Switch selection menu.

### 5.9.2.4 Alarm Acknowledge (ack)

The Alarm acknowledge option allows the external event to be used to acknowledge alarms. This has the same effect as pushing the ACK button on the display. Input closed (active) acknowledges an Alarm.

To set Switch input option to Alarm Acknowledge:

From the Switches in menu use the **UP (↑)** or **DOWN (↓)** button to select **Alarm ack** and press the **ENTER** button. Press the **EXIT** button to return to the Switch selection menu.

### 5.9.2.5 Scale set

The Scale set option allows the external event to be used to select which Chart scale to use, Scale set 1 or Scale set 2. The Scales are programmed in the Chart/Pens, Scales menu. This option works in conjunction with the FUNcTion-Scale set menu option. For example, Scale set 2 can be used to expand the scale values in Scale set 1.

To set Switch input option to Scale set:

From the Switches in menu use the **UP (↑)** or **DOWN (↓)** button to select **Scale set** and press the **ENTER** button. Press the **EXIT** button to return to the Switch selection menu.

### 5.9.2.6 Record Rate

The Record Rate option allows the external event to be used to change the record sampling rate. The Record Rate is set in Record Setup, Record Rate menu option. If the switch is open (inactive), the recording will be at the Low Record Rate. If the switch is closed (active), the recording will be at the High Record Rate. This option works in conjunction with the FUNcTion-Record speed menu option. The last operation is current - that is if an external event set the high speed, then the user used the menu to set the low speed. The recording remains at the low speed until the external event is reasserted (in this case inactive then active again to change back to high speed).

To set Switch input option to Record Rate:

From the Switches in menu use the **UP (↑)** or **DOWN (↓)** button to select **Rec Rate** and press the **ENTER** button. Press the **EXIT** button to return to the Switch selection menu.

Repeat these procedures for the other Switches.

## 5.9.3 Event messages

The Event messages option allows the user to enter custom messages for Events. The Recorder has three switch inputs that can trigger an Event each time the switch Opens or Closes. Each time an Event occurs a message will be printed on the Alarm/Event data log and if enabled, is logged in the Event file on the disk/card. Each message may be 10 characters in length. An Event message can be programmed for each switch



opening and for each switch closing. The default messages are OPEN and CLOSE. To turn Event messages off set the message to "" (null) and it will not be displayed or logged.

**NOTE:** If the Event messages are changed after an Event file has been opened on the disk, it is necessary to rename the Alarm file or use a new disk/card in order to reflect the new Event message in the file.

To program Event messages:

From the Digital I/O menu, use the **UP (↑)** or **DOWN (↓)** button to highlight **Event msgs** and press the **ENTER** button. Use the **UP (↑)** or **DOWN (↓)** button to select the Event number (1, 2 or 3) and status (open or closed) to be programmed and then press the **ENTER** button. You will be prompted with "→XXXXXXXXXX←". Use the alphanumeric keypad to enter your Event message and then press the **ENTER** button. The display will return to the list of Event numbers/statuses. Repeat this process for each Event number/status that you want to program. Once all Event numbers/statuses have been programmed, press the **EXIT** button to return to the Digital I/O menu.

## 5.10 Com ports

The Com ports menu option allows the user to configure the serial port, set the Recorder Network ID, and setup the modem attached to the RS232 port. The menu options are identical for any type of communication option, if any, fitted to the Recorder. There are three choices of communication options: RS232, RS485 or Ethernet. Note that the modem will only function with the RS232 option.

To program the Com ports options:

From the Program menu use the **UP (↑)** or **DOWN (↓)** button to highlight **Com ports** and then press the **ENTER** button. The Com ports menu will be displayed with three options: **Com Port**, **Network ID**, and **Modem Setup**. Use the **UP (↑)** or **DOWN (↓)** button to select the option you wish to program and then press the **ENTER** button. The options are described in the following sections.

### 5.10.1 Com Port

The Com Port option allows the user to configure the serial port.

To program the Com Port:

From the Com ports menu, use the **UP (↑)** or **DOWN (↓)** button to highlight **Com Port** and press the **ENTER** button. The Com Port Setup menu will have the following options: **Protocol**, **Port setup**, **Network ID**, **Modem Setup**, and **Ethernet**. These options are described in the following sections.

#### 5.10.1.1 Protocol

The Protocol option allows the user to assign the Protocol as Modbus RTU, Modbus ASCII, or Demand Data.

To set the Protocol option:

From the Com Port Setup menu use the **UP (↑)** or **DOWN (↓)** button to highlight **Protocol** and press the **ENTER** button. The Protocol menu will be displayed with three options: **Modbus rtu**, **Modbus asc** and **Demand data**. These options are mutually exclusive, and the highlighted option is active. The options are described in the following sections.

##### 5.10.1.1.1 Modbus RTU

Modbus RTU is a binary encoded output.

To select Modbus RTU:

From the Protocol menu use the **UP (↑)** or **DOWN (↓)** button to select **Modbus rtu** and press the **ENTER** button to activate. Press the **EXIT** button to return to the Com Port Setup menu.

### 5.10.1.1.2 Modbus ASCII

Modbus ASCII is an ASCII output.

To select Modbus ASCII:

From the Protocol menu use the **UP (↑)** or **DOWN (↓)** button to select **Modbus asc** and press the **ENTER** button to activate. Press the **EXIT** button to return to the Com Port Setup menu.

### 5.10.1.1.3 Demand Data

This option allows the user to configure the unit to send a time stamp and the current value of any selected data points to an ASCII serial printer. The data is sent when a selected event occurs. No header is printed, and each event will have a separate line with the time stamp and each channel separated with a semi-colon (;). For example, with channels 1 through 4 turned on to print, when 4 separate events occur, you will get an output similar to the following:

```
::10:55:39;00001;00006;00011;00016  
::10:56:01;00001;00006;00011;00016  
::10:56:05;00006;00011;00016;00021  
::10:56:07;00007;00012;00017;00022
```

To set up Demand Data:

From the Protocol menu use the **UP (↑)** or **DOWN (↓)** button to highlight **Demand data** and press the **ENTER** button. The Demand data menu will be displayed with two options: **Points** and **Demand evnt #**.

#### a. Points

The user may select which of the fifteen available points are to be sent to the printer. Ensure that points you do not wish to send to the printer, or that have no data attached, are not turned on to send.

To turn the points on or off:

From the Demand data menu use the **UP (↑)** or **DOWN (↓)** button to highlight **Points** and press the **ENTER** button. A pop up window will display “point 1=yes” or “point 1=no”. Use the **UP (↑)** or **DOWN (↓)** button to select the point you wish to turn on or off, and then press the **YES** button to turn it on or the **NO** button to turn it off. The next point number will be displayed. Repeat until all points have been set as desired and then press the **ENTER** button to return to the Demand data menu.

#### b. Demand Event (evnt) #

Demand Event allows the user to select which Event will trigger the unit to print. The Event number is the digital input number for the external event (1, 2, or 3). Selecting 0 disables the Demand Event option.

To program Demand Event:

From the Demand data menu use the **UP (↑)** or **DOWN (↓)** button to highlight **Demand evnt #** and press the **ENTER** button. You will be prompted with “Demand evnt #? X”. Use the **UP (↑)** or **DOWN (↓)** button to select the desired Demand Event input number and press the **ENTER** button.

### 5.10.1.2 Port setup

The Port setup option allows the user to select a baud rate of 300, 1200, 2400, 4800, 9600, 19200, 38400, 57600 or 115200 and assign the bits per character, parity, and stop bits.



To setup the Port:

From the Com Port Setup menu use the **UP** (↑) or **DOWN** (↓) button to highlight **Port setup** and press the **ENTER** button. The Baud Rate menu will display a list of nine options: **300 baud**, **1200 baud**, **2400 baud**, **4800 baud**, **9600 baud**, **19200 baud**, **38400 baud**, **57600 baud** and **115200 baud**. Use the **UP** (↑) or **DOWN** (↓) button to select the desired baud rate and press the **ENTER** button.

You will be prompted with “bits/chr? X”. By default the Com Port uses 8 bits of data for the character size. Use the **UP** (↑) or **DOWN** (↓) button to set the desired bits per character and press the **ENTER** button.

You will be prompted with “parity? N”. Use the **UP** (↑) or **DOWN** (↓) button to select either **N** (None), **E** (Even) or **O** (Odd) to match your communications device, and then press the **ENTER** button.

You will be prompted with “stop bits? X”. Use the **UP** (↑) or **DOWN** (↓) button to select either **1** or **2** to match your communications device, and then press the **ENTER** button. Press the **EXIT** button to return to the Com Port Setup menu.

### 5.10.1.3 Network ID

This is a duplicate menu item. Refer to section 5.10.2.

### 5.10.1.4 Modem Setup

This is a duplicate menu item. Refer to section 5.10.3.

### 5.10.1.5 Ethernet

This option allows the user to configure the unit for Ethernet connection.

To set up the Ethernet option:

From the Com Port Setup menu use the **UP** (↑) or **DOWN** (↓) button to highlight **Ethernet** and press the **ENTER** button. The Ethernet menu will be displayed with three options: **IP addr**, **Subnet mask**, and **Server addr**. These options are described in the following sections.

#### 5.10.1.5.1 IP address (addr)

The IP address is a unique address used by the network to get messages to or from the Recorder. See your network administrator to obtain a valid IP address.

To set the IP address:

From the Ethernet menu use the **UP** (↑) or **DOWN** (↓) button to highlight **IP addr** and press the **ENTER** button. Use the multi-page alphanumeric keypad to enter a valid IP address and then press the **ENTER** button to return to the Ethernet menu.

#### 5.10.1.5.2 Subnet mask

The Subnet mask determines what IP addresses are considered to be on the same Subnet. A typical value for a Subnet mask is 255.255.255.0.

To set the Subnet mask:

From the Ethernet menu use the **UP (↑)** or **DOWN (↓)** button to highlight **Subnet mask** and press the **ENTER** button. Use the multi-page alphanumeric keypad to enter a Subnet mask and then press the **ENTER** button to return to the Ethernet menu.

#### 5.10.1.5.3 Server address (addr)

This option is used to set the IP address of the PC running the name Server used in the *Guardian Software* package. If you don't have this software, this address may be left blank.

To set the name Server address:

From the Ethernet menu use the **UP (↑)** or **DOWN (↓)** button to highlight **Server addr** and press the **ENTER** button. Use the multi-page alphanumeric keypad to enter the IP address of the PC running the name Server and then press the **ENTER** button to return to the Ethernet menu.

**NOTE:** Whenever any of the above options are changed, the Recorder must be restarted before the changes will take effect.

When using the optional *Companion Software*, you must first make a connection using the E-Bridge program before using the Ethernet to connect to a Recorder. Double click on the E-Bridge icon. Double click on its icon on the system tray (or right click then select enable) to open the window. If the Recorder you want is not in the list, add its IP address and a description then press the save list button so the information will be remembered next time. Select the IP address you want to connect and then press the connect button. The Connect column should change from No to Yes.

**NOTE:** Only one Recorder can be connected at a time.

The Number of Retries and Ethernet timeout are the only other settings in this dialog box that have any effect on the Ethernet connection. Once a connection is made, the communications are the same as for a serial port. If communications stop, you may have to reset the connection by right clicking on the E-Bridge icon on the system tray and selecting Reset.

### 5.10.2 Network ID

The Network ID, or unit address, assigns a user programmed Recorder ID number for use in multidrop Modbus environments.

To program the Network ID:

From the Com Ports menu use the **UP (↑)** or **DOWN (↓)** button to highlight **Network ID** and then press the **ENTER** button. You will be prompted with "net id→XXX←". Use the numeric keypad to enter a Network ID between 1 (default) and 255. When the correct Network ID is displayed, press the **ENTER** button to return to the Com Ports menu.

**NOTE:** Even if you are not using the unit in a Modbus environment a Network ID is still required to communicate with the *Companion Software*.

### 5.10.3 Modem Setup

This menu option allows the user to enable and set up a modem string for a modem connected to the RS232 port. A modem is not supported on the RS485 port. If enabled, the start up string is sent to the modem to set it in the following mode:

- Use factory defaults
- Assume DTR is always on
- Disable ALL responses to the com port
- Auto answer on the first ring
- Connect at 9600 baud
- Use memory profile 0
- Store setup in memory profile zero

Not all modems obey the same instructions. The user can edit the default initialization string to work with any "Hayes Extended Mode compatible" modem which may not be that compatible.

To set up the modem:

From the Com ports menu use the **UP (↑)** or **DOWN (↓)** button to highlight **Modem Setup** and then press the **ENTER** button. The Modem Setup menu will display two options: **Modem Enable** and **Modem String**. These options are described in the following sections.

#### 5.10.3.1 Modem Enable

The Modem Enable option allows the user to enable or disable modem support.

To enable or disable modem support:

From the Modem Setup menu use the **UP (↑)** or **DOWN (↓)** button to highlight **Modem Enable** and then press the **ENTER** button. The display will read "modem=YES\*" if the modem is enabled or "modem=NO\*" if the modem is disabled. Press the **YES** or **NO** button to enable or disable the modem and then press the **ENTER** button to return to the Modem Setup menu.

#### 5.10.3.2 Modem String

The Modem String option allows the user to edit the initialization string sent to the modem.

To change the Modem String:

From the Modem Setup menu, use the **UP (↑)** or **DOWN (↓)** button to highlight **Modem String** and the press the **ENTER** button. You will be prompted with "→XXXXXXXXXX←". Use the multi-page alphanumeric keypad to enter the initialization string for the modem and press the **ENTER** button to return to the Modem Setup menu. A maximum of 30 characters may be entered.

The following is a listing of modems, baud rates and modem strings:

Modem String for 9600 baud for Zoom, Rockwell, Boca, Best Data, Viking, Comstar, or Practical Peripherals Modems:

```
AT&F&D0Q1S0=1S37=9%C0&Y0&W0
```

Modem String for 9600 baud for US Robotics (3COM), Cardinal, or Phoebe Modem:

```
AT&F&D0Q1S0=1&U6&N6&K0&M0Y0&W0
```

Modem String for 19,200 or 38,400 baud for Zoom, Rockwell, Boca, Best Data, Viking, Comstar, or Practical Peripherals Modems supporting V.34:

```
AT&F&D0Q1S0=1%C0+MS=11,0,19200
```

US Robotics (3COM), Cardinal and Phoebe modems do not work at 19,200 or 38,400 baud rates. NewCom modems are not supported.

Refer to the modem manual for other modems. The modem needs to be set up as follows.

Operation	Rockwell etc.	US Robotics, etc
Modem Attention call	AT	AT
Load factory defaults	&F	&F
Ignore DTR line	&D0	&D0
Quiet, no response to DTE	Q1	Q1
Auto answer on the first ring	S0=1	S0=1
Set 9600 baud	S37=9	&U6&N6
No compression	%C0	&K0
No ARQ	n/a	&M0
Use profile 0 on wake up	&Y0	Y0
Store settings into profile 0	&W0	&W0
Set V.34 modulation, no automode, 19200 bps	+MS=11,0,19200	n/a
Set 19200 baud	n/a	&n10

The entire string may not fit in the display window. Use the **LEFT** (←) or **RIGHT** (→) button to navigate through the string. The modem string is then sent once you return to the Program menu or whenever power is applied to the Recorder. Refer to Chapter 2.4 for modem connection.

## 5.11 System

The System menu option allows the user control the Beeper, set Passcodes or Alternate Languages, and configure the Parallel Printer Port.

To modify this System parameters:

From the Program menu use the **UP** (↑) or **DOWN** (↓) button to highlight **System** and then press the **ENTER** button. The System menu will be displayed as shown in Figure 5-9. Use the **UP** (↑) or **DOWN** (↓) button to select the option you wish to program and then press the **ENTER** button. The options are described in the following sections.



**Figure 5-4**  
**System Menu**

### 5.11.1 Beeper

The Beeper menu option allows the user to turn the Beeper On or Off. If On, the Beeper provides audible feedback to button/key presses, indicates errors and beeps on alarm condition.

To turn the Beeper On or Off:

From the System menu use the **UP** (↑) or **DOWN** (↓) button to highlight **Beeper** and then press the **ENTER** button. The current Beeper status will be displayed as "Beeper=YES\*" or "Beeper=NO\*". Press the **YES** button to turn the Beeper On, or the **NO** button to turn the Beeper Off and the press the **ENTER** to return to the System menu.

### 5.11.2 Passcodes

The Passcodes menu option allows the user to program a Passcode to protect the FUNCTION menu and/or the PROGRAM and Hidden menus from unauthorized changes. Once a Passcode is set, it must be entered to gain access to the respective menu. Separate Passcodes can be set for either. Note that if a Passcode is forgotten, you will not be able to change the configuration of the unit. The only way to change or delete a Passcode is to know the present Passcode. **Treat Passcodes with respect.**

To enter or change a Passcode:

From the System menu use the **UP (↑)** or **DOWN (↓)** button to highlight **Passcodes** and then press the **ENTER** button. The Passcodes menu will be displayed with two options: **Function key** (to protect the FUNCtion menu) and **Program key** (to protect the PROGram and Hidden menus).

Use the **UP (↑)** or **DOWN (↓)** button to select **Function key** (to protect the FUNCtion menu) or **Program key** (to protect both the PROGram and Hidden menus) and then press the **ENTER** button. You will be prompted with a blank Passcode, and if you press the **ENTER** button at this point you will effectly clear the Passcode for that key. Entering a passcode of 000000 or all spaces is equivalent to setting NO Passcode. Use the numeric keypad to enter a Passcode from 1 to 6 characters in length. You will not be asked to verify the Passcode, but the Passcode will be displayed as you enter it so that you can check it for accuracy. **WRITE THE PASSCODE DOWN AND KEEP IT SOMEPLACE SAFE.** Once the Passcode is entered as desired, press the **ENTER** button to return to the Passcode menu. Repeat the same process for the other menu option. The Passcodes for each key may be the same or different, or may be disabled.

Once a passcode is entered, you will be prompted for it the next time you try to enter the respective menu. If you do not enter it correctly, you will be denied access to the menu.

### 5.11.3 Alternate (Alt.) Language

The Alternate Language menu option allows the user to select, load and save alternative language files.

To program the Alternate Language options:

From the System menu use the **UP (↑)** or **DOWN (↓)** button to highlight **Alt. Language** and then press the **ENTER** button. The Alternate Language menu will display four options: **Select Lang.**, **Load Alt. Lang.**, **Save English** and **Save Alt. Lang.** These options are described in the following sections.

#### 5.11.3.1 Select Language (Lang.)

The Select Lang. option allows the user to toggle between the English Language and an Alternate Language.

To Select a Language:

From the Alternate Language menu use the **UP (↑)** or **DOWN (↓)** button to highlight **Select Lang.** and then press the **ENTER** button. This will toggle between English and any loaded Alternate Language. If an Alternate Language is not loaded, the error message “No Other Language” will be displayed. Press the **OK?** button to clear the error message.

#### 5.11.3.2 Load Alternate Language (Alt. Lang.)

The Load Alt. Lang. option allows the user to load an Alternate Language from the file.

To Load an existing Language file:

From the Alternate Language menu use the **UP (↑)** or **DOWN (↓)** button to highlight **Load Alt. Lang.** and then press the **ENTER** button. A pop up window will display “load language=NO\*”. Press the **YES** button to change the display to read “load language=YES?” and then press the **ENTER** button. The unit will look on the disk/card for any Language files which will be displayed in the File Directory. If more than one Language file exists, the directory will list them one above the other, with the current file to be loaded indicated by the arros alongside it. Use the **UP (↑)** or **DOWN (↓)** button to select desired Language file and then press the **ENTER** button. The unit will load the selected Language file from the disk/card.

### 5.11.3.3 Save English

The Save English menu option allows the user to save the English Language file to disk/card for editing.

To Save the English Language file to disk/card:

From the Alternate Language menu use the **UP (↑)** or **DOWN (↓)** button to highlight **Save English** and then press the **ENTER** button. The Disk Status Window will show "SAVE LANG" and a window will pop up when the Language file has been saved to indicate "Language Saved". Press the **OK?** button to return to the Alternate Language menu.

### 5.11.3.4 Save Alternate Language (Alt. Lang.)

The Save Alt. Lang. menu option allows the user to save the Alternate Language file to disk/card.

To Save the Alternate Language file to disk:

From the Alternate Language menu use the **UP (↑)** or **DOWN (↓)** button to highlight **Save Alt. Lang.** and then press the **ENTER** button. The Disk Status Window will show "SAVE LANG" and a window will pop up when the Language file has been saved to indicate "Language Saved". Press the **OK?** button to return to the Alternate Language menu.

## 5.11.4 Printer out

The Printer out menu option allows the user to configure the Parallel Printer Port to print point data and/or events at a specific interval.

To set the Printer out options:

From the System menu use the **UP (↑)** or **DOWN (↓)** button to highlight **Printer out** and then press the **ENTER** button. The Printer out menu will be displayed with five options: **Data**, **Events**, **Data Interval**, **Characters/Line** and **Data Lines**. These options are described in the following sections.

### 5.11.4.1 Data

The Data option allows the user to enable or disable the printing of point data to the printer.

To enable or disable the printing of point data:

From the Printer out menu use the **UP (↑)** or **DOWN (↓)** button to highlight **Data** and then press the **ENTER** button. A window will pop up showing the current status as "print data=NO\*" (if the unit will not print data) or "print data=YES\*" (if the unit is to print data). Press the **YES** button (to enable Data printing) or the **NO** button (to disable Data printing). If you select **YES**, you will be prompted with "point X=YES\*" or "point X=NO\*". Use the **UP (↑)** or **DOWN (↓)** button to select the point you wish to turn on or off and press the **YES** button (to turn it on) or the **NO** button (to turn it off) and automatically advance to the next point. Then press the **ENTER** button to return to the Printer out Menu.

### 5.11.4.2 Events

The Events option allows the user to enable or disable the printing of Events to the printer.

To enable or disable the printing of Events:

From the Printer out menu use the **UP (↑)** or **DOWN (↓)** button to highlight **Events** and then press the **ENTER** button. A window will pop up showing the current status as "print events=NO\*" (if the unit will not print events) or "print events=YES\*" (if the unit is to print events). Press the **YES** button (to enable Event printing) or the **NO** button (to disable Event printing). Press the **ENTER** button to return to the Printer out Menu.

**NOTE:** If Data and/or Events are set to "YES" and there is a problem with the printer (i.e. turned off, off line, etc.), the error message "Printer Problem" will appear. Set Data and/or Events to "NO" to prevent this error message from displaying until the problem has been fixed.

### 5.11.4.3 Data Interval

The Data Interval option allows the user to set the time interval (in minutes) at which Data or Events are sent to the printer.

To set the Data Interval:

From the Printer out menu use the **UP (↑)** or **DOWN (↓)** button to highlight **Data Interval** and then press the **ENTER** button. You will be prompted with “minutes→XXXX←”. Use the keypad to enter the time interval and press the **ENTER** button to return to the Printer out menu. A maximum of 1440 minutes (24 hours) may be entered. Setting the Data Interval to 0 will have the unit send Data every 15 seconds. Events print out as they occur.

### 5.11.4.4 Characters/Line

The Characters/Line option allows the user to set the number of Characters per Line (40 to 80).

To set the Characters/Line value:

From the Printer out menu use the **UP (↑)** or **DOWN (↓)** button to highlight **Characters/Line** and then press the **ENTER** button. You will be prompted with “characters/line→XX←”. Use the keypad to enter the number of Characters per Line and press the **ENTER** button to return to the Printer out menu.

**NOTE:** When printing, the Unit tag and data groupings will not split. Both will wrap around to the next line together.

### 5.11.4.5 Data Lines

The Data Lines option allows the user to set the number of Data Lines printed between headers (0 to 255).

To set the Data Lines value:

From the Printer out menu use the **UP (↑)** or **DOWN (↓)** button to highlight **Data Lines** and then press the **ENTER** button. You will be prompted with “data lines→XXX←”. Use the keypad to enter the number of Data Lines to be printed per page and press the **ENTER** button to return to the Printer out menu. Setting the Data Line value to 0 will have the unit print the header every time Data or Events are sent to the printer.

An example of the Printer out option is shown below:

Printer out menu option	Setting
<b>Data</b>	print data=YES
<b>Events</b>	print events=YES
<b>Data Interval</b>	minutes→0←
<b>Characters/Line</b>	characters/line→40←
<b>Data Lines</b>	data lines→20←

  

10/15/01	Unit Tag	
11:30:00	CH 1	0 SECS
	CH 2	5 Secs
	CH 3	10 Secs
	CH 4	15 Secs
	CH 5	20 Secs
	CH 6	25 Secs
11:30:15	CH 1	15 SECS
	CH 2	20 Secs
	CH 3	25 Secs
	CH 4	30 Secs
	CH 5	35 Secs
	CH 6	40 Secs
11:30:20	P1 HIGH 1	20
11:30:30	CH 1	30 SECS
	CH 2	35 Secs
	CH 3	40 Secs
	CH 4	45 Secs
	CH 5	50 Secs
	CH 6	55 Secs



## SAFETY NOTICE

This Safety Notice has been included to emphasize the **DANGER OF HAZARDOUS VOLTAGES** on the **REAR TERMINAL PANEL** of your instrument. **USE EXTREME CAUTION WHEN INSTALLING OR SERVICING** your instrument. Please read the entire contents of the Installation and Wiring Chapter of this manual before attempting to install or service your instrument.

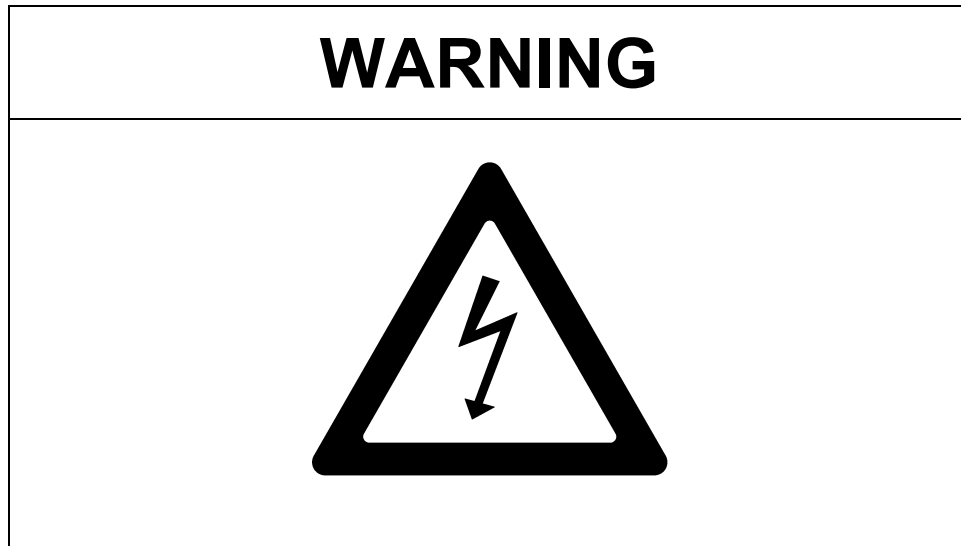

**Use Extreme caution when servicing the rear terminal of your instrument.**

# Chapter 6 Calibration

6.1 Introduction .....	6-1
6.1.1 Routine Calibration .....	6-1
6.1.2 Calibration Equipment .....	6-1
6.2 Zero Calibration .....	6-1
6.3 Scale Calibration .....	6-2
6.3.1 Calibration Scales .....	6-2
6.3.1.1 Connecting Voltage Source .....	6-2
6.3.1.2 Programming Calibration Scales .....	6-2
6.3.1.3 Calibrating the Voltage Ranges .....	6-2
6.4 RTD Current Calibration .....	6-3
6.4.1 Calibrating the RTD Current .....	6-3
6.4.1.1 Connecting Resistance .....	6-3
6.4.1.2 Calibrating the RTD Current .....	6-3
6.5 Calibration Recall .....	6-3
6.6 Factory Set .....	6-3

## 6.1 Introduction

This chapter includes the procedures to calibrate the Analog-to-Digital Converter (ADC) circuit board and the RTD current source. The actual calibration constants are automatically stored in Flash Memory on the Analog-to-Digital Converter boards.

**WARNING:** Do not attempt to perform calibration unless you are fully prepared to do so. Incorrect procedures can destroy factory calibration. Read this entire chapter before attempting to calibrate the unit.

**NOTE:** Allow the Recorder to warm up and stabilize before attempting calibration. A warm up time of 15 minutes at room temperature is recommended.

### 6.1.1 Routine Calibration

Routine calibration should be performed to maintain the accuracy of the instrument. The following items must be performed for a routine calibration:

- Zero Calibrate all channels
- Calibrate the ADC Scales
- RTD Current

### 6.1.2 Calibration Equipment

The following equipment items are necessary to calibrate the instrument:

- One precision voltage source (accurate to  $\pm 5$  microvolts) adjustable from 10 microvolts to 25 Volts
- One precision resistor 250 ohms 0.05% - Required for calibrating RTD

## 6.2 Zero Calibration

Before the Scales or RTD current are calibrated, a Zero Calibration must be done. A Zero Calibration must be done when new channels are installed into the ADC board.

To perform a Zero Calibration:

Insert a jumper onto all channels (see the Unused Input diagram in Figure 2-7). From the Hidden menu use the **UP** ( $\uparrow$ ) or **DOWN** ( $\downarrow$ ) button to highlight **ADC Control** and then press the **ENTER** button. The only available option is **Cal Adc** so just press the **ENTER** button. Use the **UP** ( $\uparrow$ ) or **DOWN** ( $\downarrow$ ) button to highlight **Cal scales** and press the **ENTER** button. Use the **UP** ( $\uparrow$ ) or **DOWN** ( $\downarrow$ ) button to select **Zero cal.** and press the **ENTER** button. A pop window with "SHORT ALL INPUTS". Press the **OK?** button. A pop window will show the readings from channel 1. Press the **CAL.** button. You will be prompted with "Are You Sure?". Press the **CAL.** button again to calibrate the channel or the press the **NO** button to cancel.

**NOTE:** Zero calibration must be done to all channels. Only the readings from channel 1 will be shown.

Once the Zero Calibration is done, remove the jumpers and press the **EXIT** button three times to get back to the Hidden menu.

## 6.3 Scale Calibration

The Recorder menu supports full calibration for the voltage and current input ranges of the instrument. Each range requires a unique calibration constant, which is automatically calculated during the calibration of each range.

### 6.3.1 Calibration Scales

Follow the procedures below to Calibrate Scales.

#### 6.3.1.1 Connecting Voltage Source

Connect the precision voltage source to any available direct input at the rear upper (lower) analog Input terminals (See Figure 2-6). Select any channel and connect the voltage source to the + and - inputs ensuring the correct polarity. Turn on the Voltage Source and allow 10 minutes for it to warm up and stabilize.

#### 6.3.1.2 Programming Calibration Scales

From the Hidden menu use the **UP (↑)** or **DOWN (↓)** button to select **ADC control** and then press the **ENTER** button. The only available option is **Cal Adc** so just press the **ENTER** button. Use the **UP (↑)** or **DOWN (↓)** button to highlight **Cal scales** and press the **ENTER** button. The Calibration Scale options will be displayed.

#### 6.3.1.3 Calibrating the Voltage Ranges

To calibrate any of the voltage ranges, a known good input must be supplied to the Recorder as shown in the table below:

Range to Calibrate	Voltage Source
150 mV	150 mV
1.25 V	1.25 V
2.5 V	2.5 V
12.5 V	12.5 V
25 V	25 V

Set the precision Voltage Source for the appropriate range. Then use the **UP (↑)** or **DOWN (↓)** button to select the range in need of calibration and press the **ENTER** button. You will be prompted with “cal input? X”. Use the **UP (↑)** or **DOWN (↓)** button to select the channel input number (1, 2, 3, 4, 5 or 6) to which the Voltage Source is connected and press the **ENTER** button. You will be prompted with “APPLY [range selected]”. With the Voltage Source connected and turned on, press the **OK?** button. A window will appear showing the reading of the Voltage Source connected.

**NOTE:** If the calibration is not correct, the value shown in the window will not be correct.

Press the **CAL.** button. You will then be prompted with “Are You Sure?”. Press the **CAL.** button to continue the calibration or the **NO** button to abort. If the **CAL.** button is pressed, the Recorder calibrates the selected range. Repeat for the remaining voltage ranges.

## 6.4 RTD Current Calibration

The ADC current source is used for RTD measurements and needs calibration for the RTD's.

### 6.4.1 Calibrating the RTD Current

The following procedure contains step-by-step instructions on Calibrating the Current source. A  $250\Omega \pm 0.05\%$  resistor must be connected across the + and - terminals of a free input and the current source return path **C** must be connected to the - input terminal. The Recorder then applies 1mA of Current through the resistance to Calibrate Current. These programming steps are discussed in menu order.

**NOTE:** Before Calibrating Currents, ensure that the Zero Calibration and 1.25 Volt Scale range has been calibrated per the previous sections as this will affect the accuracy of Current Calibration.

#### 6.4.1.1 Connecting Resistance

Select a free set of input terminals on the rear of the unit, or remove any connections from the set of terminals to be used. Connect the  $250\Omega \pm 0.05\%$  resistor across the + and - terminals of this input and connect the Current source return path **C** to the - input terminal (see Figure 6-1).

#### 6.4.1.2 Calibrating the RTD Current

To Calibrate the RTD Current:

From the Hidden Menu use the **UP** (↑) or **DOWN** (↓) button to select **ADC control** and then press the **ENTER** button. The only available option is **Cal Adc** so just press the **ENTER** button. Use the **UP** (↑) or **DOWN** (↓) button to highlight **Cal currents** and press the **ENTER** button. You will be prompted with “cal input? X”. Use the **UP** (↑) or **DOWN** (↓) button to select the channel input number (1, 2, 3, 4, 5 or 6) to which the resistor is connected and press the **ENTER** button. You will be prompted with “APPLY [resistor value]”. To allow the Recorder to detect the actual value of the Current, press the **OK?** button. A window will appear showing the reading of the Current connected. Press the **CAL.** button. You will then be prompted with “Are You Sure?”. Press the **CAL.** button to continue the calibration or the **NO** button to abort. If the **CAL.** button is pressed, the Recorder program will store the adjusted value from a nominal 1mA of Current. Calibration of Currents is complete.

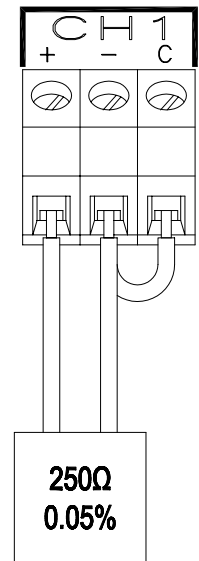

**Figure 6-1**  
Calibration  
Resistor  
Connection

## 6.5 Calibration Recall

If the calibration equipment listed above is not available, the factory Calibration for the Zero Calibration and Scales (sections 6.2 and 6.3) can be recalled. **All channels will be recalled.**

To Recall the factory Calibration:

From the Hidden Menu use the **UP** (↑) or **DOWN** (↓) button to select **ADC control** and then press the **ENTER** button. The only available option is **Cal Adc** so just press the **ENTER** button. Use the **UP** (↑) or **DOWN** (↓) button to highlight **Cal recall** and press the **ENTER** button. You will be prompted with “Are You Sure?”. Press the **YES** button to retrieve the factory Calibration settings or the **NO** button to abort.

## 6.6 Factory Set

This option is for factory use only and overwrites the default factory Calibration constants with the current ones in the analog board. This makes the Current Calibration constants the default, and it is these values that will be recalled when attempting to restore factory Calibration.

# Chapter 7 Get Data Software

7.1 Overview .....	7-1
7.2 Microsoft Windows™ Installation .....	7-1
7.3 The Menu .....	7-1
7.3.1 Export .....	7-1
7.3.1.1 Exported File Format – Graph Data .....	7-1
7.3.1.2 Export Dialog Box .....	7-1
7.3.1.2.1 Start Time and Date .....	7-2
7.3.1.2.2 End Time and Date .....	7-2
7.3.1.2.3 Time Format .....	7-2
7.3.1.2.4 Date Format .....	7-2
7.3.1.2.5 Intervals .....	7-2
7.3.1.3 Exported File Format - Alarms/Events .....	7-2
7.3.2 Help .....	7-3
7.3.2.1 About .....	7-3
7.3.2.2 Contents .....	7-3
7.4 Tutorial .....	7-3
7.4.1 Scroll bars .....	7-3
7.4.2 Using Dialog Boxes .....	7-3
7.5 Appendix .....	7-4
7.5.1 File Types .....	7-4
7.5.2 Supplementary Documentation .....	7-4

## **COPYRIGHT NOTICE, LICENSE AND WARRANTY**

All product names and services identified throughout this document are trademarks or registered trademarks of their respective companies.

This software may not be duplicated (other than ONE copy for personal archival purposes) or redistributed without the written consent.

The user has the right to use one copy of the enclosed software on a single computer (CPU).

Except for the limited warranty covering the physical disk(s), the material and information contained within this package are provided “as is” without warranty of any kind, expressed or implied, including without limitation any warranty concerning the accuracy, adequacy, or completeness of such information or the results to be obtained from using such information or material. Neither the software provider nor the author shall be responsible for any claims attributable to errors, omissions or other inaccuracies in either the software or the manual, and in no event shall the software provider or the author be liable for direct, indirect, special, incidental, or consequential damages arising out of the use of such information and material. By using this product you agree to the terms of the copyright and warranty.

## 7.1 Overview

The Get Data Software is a 16 bit software package that runs under the Microsoft Windows™ 95/ 98/ ME/ NT/ XP Operating Systems and enables the user to export files to spreadsheets such as Excel™ and Quattro™. The data produced by the Recorder are in a proprietary format and must be read with our software.

## 7.2 Microsoft Windows™ Installation

Exit from any open applications. Place the supplied 3½” disk into your floppy drive. Select **Start, Run**. Type in **A:\SETUP** or **B:\SETUP** depending on which drive you inserted the floppy disk into. Press the **OK** button. This will run the setup program which will automatically install your software. You will be asked to enter the destination drive and directory where you wish to have the software installed. If you do not wish to accept the default, type in the destination you want and press Enter or click the “OK” button. Follow the instructions.

To run the program, double-click on the icon on your desktop or use the Start button and select it from the Programs list.

## 7.3 The Menu

The menu bar displays the primary selections available and each selection controls a specific portion of the program. In this case the only available menus are **Export, Exit, and Help**.

The simplest method of accessing the menu is with the mouse. Simply position the mouse pointer on the menu selection required and press the left mouse button. Alternatively, you can use the keyboard by pressing and holding the ‘Alt’ key and then pressing the highlighted (underlined) letter of the top menu option. To make selections from the sub menus, just type in the underlined letter of the desired selection. A third method is to press and release the ‘Alt key; then use the arrow keys to move around through the menus.

The menu items are as follows:

### 7.3.1 Export

This menu item takes the information from the file created by the Recorder and creates a file that can be read by other programs. Graph or Alarm/Event data can be exported in comma separated variables format (CSV), which can be read by word processing and spreadsheet programs.

#### 7.3.1.1 Exported File Format – Graph Data

To export graph data, select File, Export. From the first dialog box, select the disk filename(s) that has(have) the source data that you want to be exported. The file will have a \*.DT\* extension. Then the Export Dialog window will be presented as shown in Figure 7-1. The Export Dialog Box is explained in the next section.

#### 7.3.1.2 Export Dialog Box

The Export Dialog Box allows the user to select the start and end times, the format for the time and date, and optionally break the data up into smaller files based on a time interval.

The data is stored in engineering units as setup on the Recorder (e.g. degrees C, Volts, pressure, etc.). Temperature, for example, is exported in actual degrees.

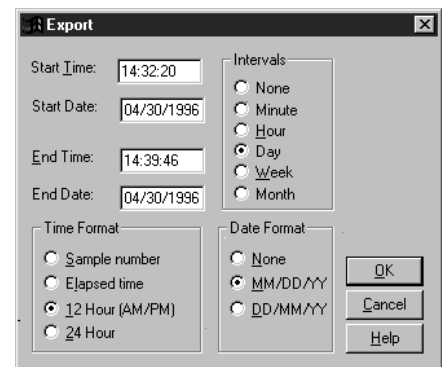

Figure 7-1 Export Dialog Box

#### 7.3.1.2.1 Start Time and Date

Select the time and date to start exporting data, thus allowing part of the file to be exported.

#### 7.3.1.2.2 End Time and Date

Select the time and date to stop exporting data.

#### 7.3.1.2.3 Time Format

Select the time format either as Sample number, where each value output will be numbered; Elapsed time, where the first sample is time 0:00:00 and each sample is then time incremented; or select an absolute time format, 12 or 24 hour.

#### 7.3.1.2.4 Date Format

Select either month day MM/DD/YYYY (American) or day month representation DD/MM/YYYY (European) or None to suppress the date.

#### 7.3.1.2.5 Intervals

The Intervals option allows the user to export “Blocks” of data rather than the whole file which may be too large for certain spreadsheets. The block may be selected as intervals of one Minute, one Hour, one Day, one Week or one Month. An interval of None exports the entire file. Select the desired option.

Once the export options have been selected, click on the OK button or press [Enter]. A dialog box will appear to select or enter the filename (make sure to add a .CSV extension for use with Microsoft Excel) and location of the export file. When a filename has been selected/entered, click on the Save button and the data will be exported into that file.

**Note:** When exporting data using any interval (other than None), the filename must be less than 8 characters to allow for a sequential number for multiple files.

#### 7.3.1.3 Exported File Format - Alarms/Events

To export Alarm/Event data, select File, Export. A dialog box will appear to select or enter the filename (make sure to add a .CSV extension for use with Microsoft Excel) and location of the export file. When a filename has been selected/entered, click on the Save button and the data will be exported into that file.

The exported file for an Alarm/Event has a header as follows: “Date”, “Time”, “Point/Event”, “Type”, “Value”. Each line afterwards has a line of data that corresponds to each line in the Alarms/Events window that is being exported. The data on each line follows the format indicated by the labels above.

Alarm Event Exported File Format Example:

```
“Date”,“Time”,“Point/Event”,“Type”,“Value”  
04/30/1996,02:32:30 pm,3,“High Peak:”, 51.970  
04/30/1996,02:33:01 pm,3,“Peak Reset:”, 51.970  
04/30/1996,02:32:52 pm,4,“Low Peak:”, -95.336
```



## 7.3.2 Help

### 7.3.2.1 About

Opens a window that gives the title of the program, version number, and company information.

### 7.3.2.2 Contents

Shows the “Contents” page of the help file.

## 7.4 Tutorial

### 7.4.1 Scroll bars

A scroll bar is used to move the object in the associated window (lists, etc). There are two types of scroll bars, vertical and horizontal. The vertical scroll bar will be described, but the horizontal scroll bar is analogous.

The scroll bar has five parts to it (see Figure 7-2). An up arrow (A), a top region (B - not completely shown in Figure 7-2), a thumb button/bar (C), a bottom region (D), and a down arrow (E). The up arrow moves the associated object in the windows up one unit. The down arrow moves the object down one unit. The ‘unit’ may be a single line of text or a segment of the graph. To move the object by this single increment, place the cursor (using the mouse) over either button and press the **left** button once.

The thumb button shows where the visible part of the object is relative to the beginning and end. Every time the object is moved, the thumb button reflects its new position. The thumb button may be held and dragged by putting the cursor (using the mouse) on it and then pressing and holding the **left** mouse button while dragging the mouse and consequently the thumb button up or down. The object will be moved accordingly.

Pressing the left mouse button when the mouse cursor is pointing to the top region (the area on the scroll bar between the up arrow and the thumb button), the object will move up by one “page”. The object will move down one “page” when this is done on the bottom region.

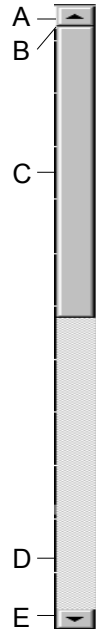

Figure 7-2  
Scroll Bar

### 7.4.2 Using Dialog Boxes

A dialog box is a special window where several selections can be made, or different types of data can be displayed or entered. Although dialog boxes may all appear very different, they all have some common functions.

To edit any selection in an area of a dialog box, that area must be made current (highlighted). This can be done by pointing to that area of the dialog box (e.g. a list of radio buttons) with the mouse cursor and pressing the left mouse button, or keep pressing the [TAB] key until that part is current (highlighted), or press and hold [ALT] and the underlined letter in the label for that section. All keyboard entries are directed to the current section of the current window. Therefore, what a key does depends on which area is currently active.

## 7.5 Appendix

### 7.5.1 File Types

The software works with various file types, both on the data card and from the computer disk. Some of the file types are PC specific, while others are used both by the computer and the Recorder. The files may have any name up to a maximum of eight characters. It is the last three characters appended to the filename that define the file types, and these are preset by the system. The following are the file types that are used:

wgetdata.INI	Text file use by this software only. Contains initialization data.
*.DT*	Data files from the Recorder. Use the export command to translate the file.
*.DAT, *.CSV	Exported data file. Created by this software when you export data.

**NOTE:** If the filename is unimportant, it is indicated with an asterisk (\*) and may be user defined.

### 7.5.2 Supplementary Documentation

The following documentation may be helpful in setting up or understanding this software:

- Recorder User's Manual
- Microsoft DOS Manual
- Microsoft Windows Manual

# Appendix A

## Configuring a 1-5 Vdc input for a 0-250 psig pressure transducer

1. Begin configuration by touching the **MENU** button in the lower right hand corner of the screen. This will bring up the Command button bar. Touch the **PROG** button to enter into the main program menu.

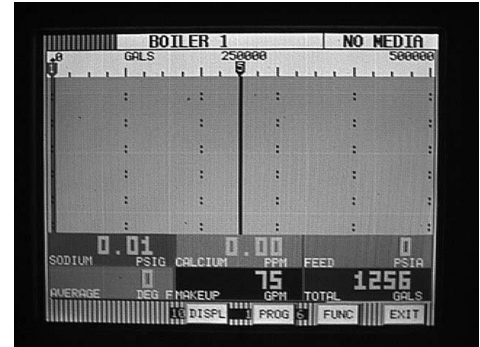

2. Once in the main program menu use the up/down arrow keys to select **Points**, then touch **ENTER**.

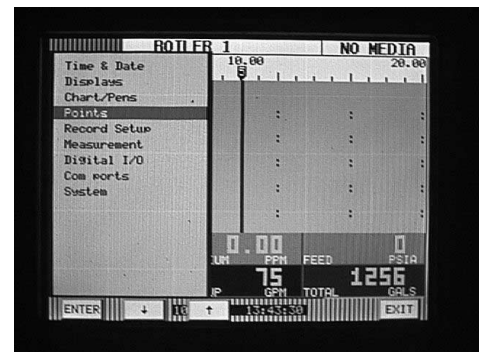

3. **Prog point** and **Constants** will appear. Using the up/down arrow keys select **Prog point** and touch **ENTER**.

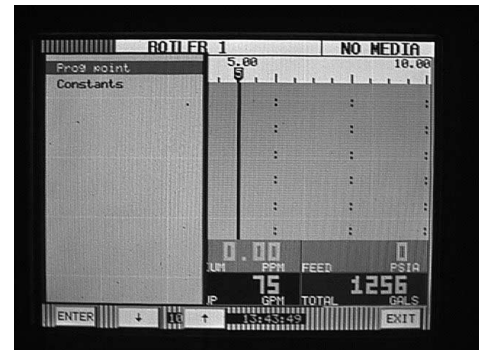

4. The numbers **1-9** and letters **A-F** represent the 15 channels that can be set up. Touch the number or letter that represents the input or channel you wish to configure. For this example use number **1** and touch **ENTER**.

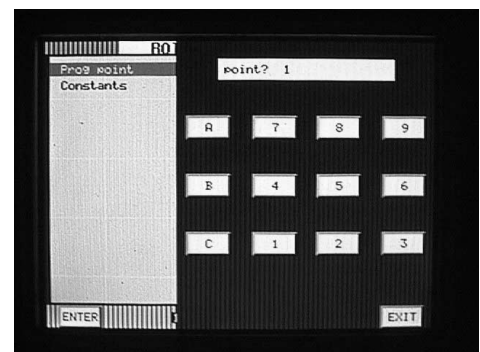

Appendix A – Configuring a 1-5 Vdc input for a 0-250 psig pressure transducer

- If you are configuring the Recorder for the first time, a menu having **Setup pt**, **Copy pt** and **Restore pt** will appear. If you are changing a point that you have already configured, the menu will have **Modify pt** and **Delete pt**. Depending on which menu appears, use the up/down arrow keys to select **Setup pt** or **Modify pt** and then touch **ENTER**.

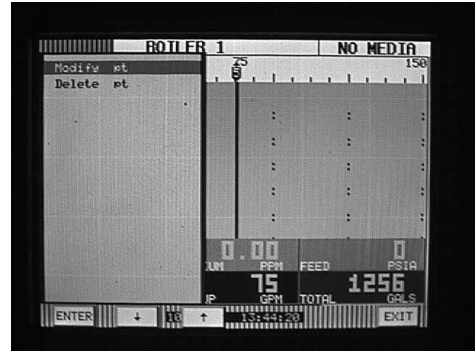

- The menu containing types of inputs should now be displayed. Use the up/down arrow keys to select **Linear** and then touch **ENTER**.

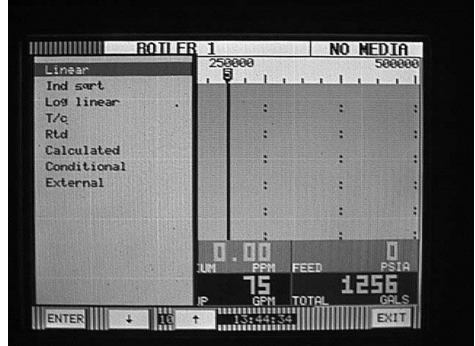

- The menu displaying types of linear inputs should now appear. (Selections may appear different from the screen example to the left.) For this example use the up/down arrow keys to select the **12.5V** (for 12.5 Volt) range then touch **ENTER**.

The menu starting with **Point tag** will appear. Using the up/down arrow keys select **Point tag** and touch **ENTER**.

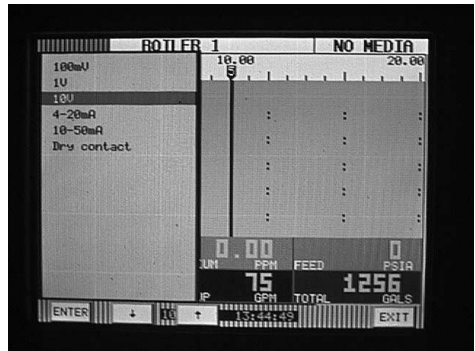

- An alphanumeric keypad will be displayed. This is where you enter a word or phrase (up to 10 characters\*) that describes this particular point. There are multiple pages of letters, numbers and symbols that can be used. Use the **PAGE**, **PAGEBK** and **SHIFT** keys to access different characters. For this example enter the word **INLET** and touch **ENTER**.

\* Only 8 characters will be displayed on the screen although all ten will be recorded and can be displayed using the *Companion Software*.

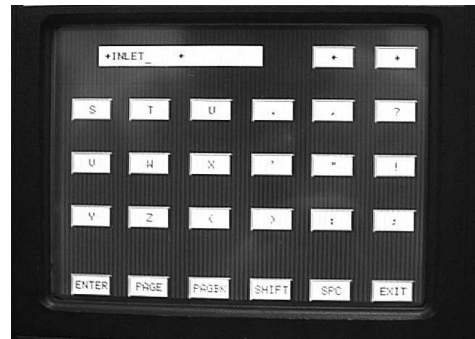

- The menu starting with **Point tag** will appear again. Using the up/down arrow keys select **Input scale** and touch **ENTER**. A numeric keypad will appear with **10→ ←** displayed. This is the point that you enter the low range of your input signal. For this example (1-5 Volts DC) enter **1.00** as the low range and touch **ENTER**.

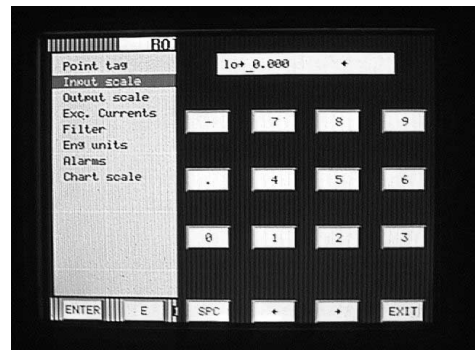

Appendix A – Configuring a 1-5 Vdc input for a 0-250 psig pressure transducer

10. The numeric keypad will now prompt you for the **hi** end of your input signal. For this example enter **5.00** and touch **ENTER**.

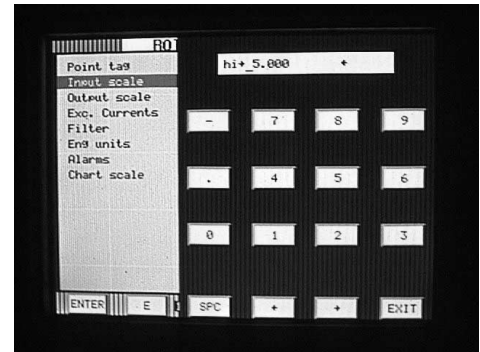

11. Using the up/down arrow keys select **Output scale** and touch **ENTER**.

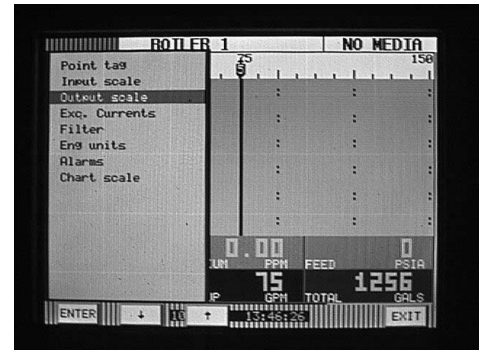

12. You will now be prompted for the number of decimal places that you would like to display and record. Using the up/down arrow keys you can select 0, 1, 2, 3, 4, or 5 decimal places. For this example select 2 and touch **ENTER**.

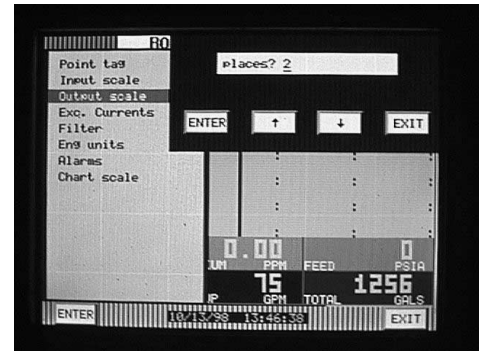

13. Another numeric keypad will appear prompting you for the **lo** end of your output scale. For this example (0-250 psig) enter **0.00** and touch **ENTER**.

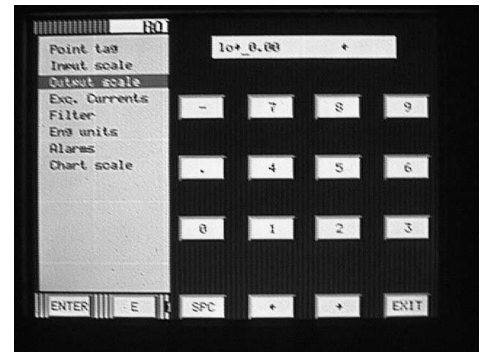

14. You will now be prompted for the **hi** end of your output scale. You should enter **250.00** and touch **ENTER**.

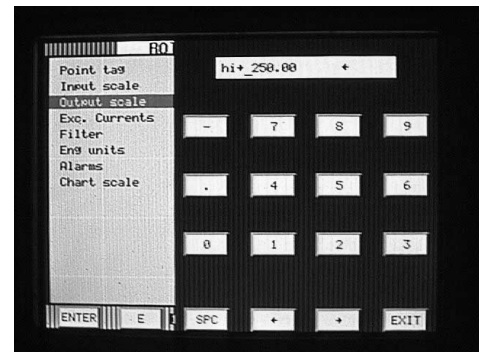

Appendix A – Configuring a 1-5 Vdc input for a 0-250 psig pressure transducer

- Using the up/down arrow keys select **Eng units** and touch **ENTER**. The alpha-numeric keypad will now be displayed allowing you to enter up to five characters to describe the engineering units for this particular point. There are multiple pages of text and symbols that can be used. Use the **PAGE**, **PAGEBK** and **SHIFT** keys to access different characters. For this example (0-250 psig) enter **PSIG** and touch **ENTER**.

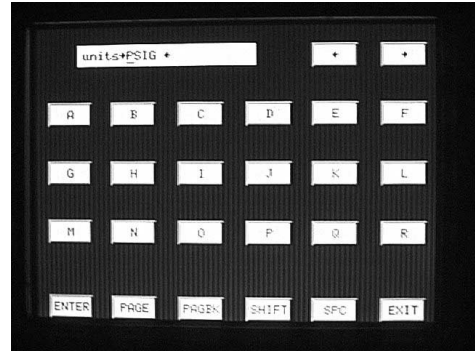

- Using the up/down arrow keys select **Chart scale** and touch **ENTER**. A menu prompting you to choose a chart scale will appear (**chart scl=**). Using the up/down arrow keys you can select letters **A-H** for a total of 8 different scales. For this example select chart scale **A** and touch **ENTER**. Then touch **EXIT**.



- You will now be prompted with **keep setup?** Touch **YES** and you will be returned to the main program window.

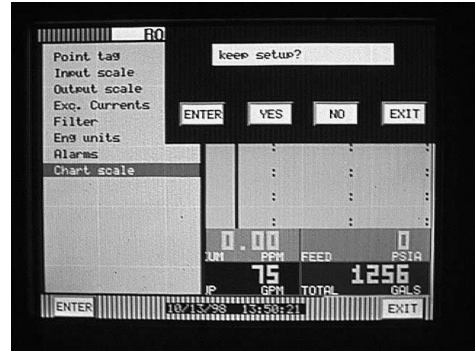

- Use the up/down arrow keys to select **Chart/Pens** and touch **ENTER**.

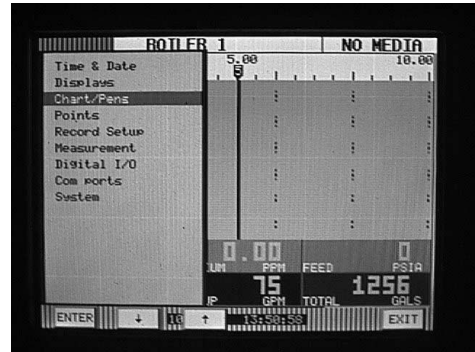

- The Chart/Pens menu will be displayed. Using the up/down arrow keys select **Scales** and touch **ENTER**.

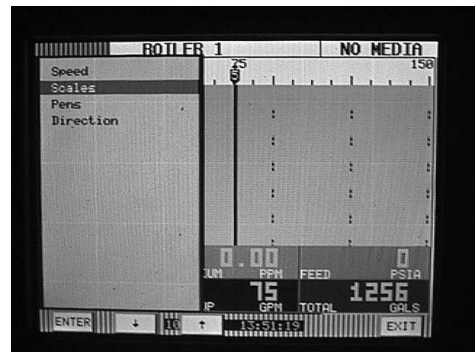

Appendix A – Configuring a 1-5 Vdc input for a 0-250 psig pressure transducer

20. You will be prompted with **scale?** (1A-2H will also be displayed) Use the up/down arrow keys to scroll through the different scales until **1A** is displayed and then touch **ENTER**.

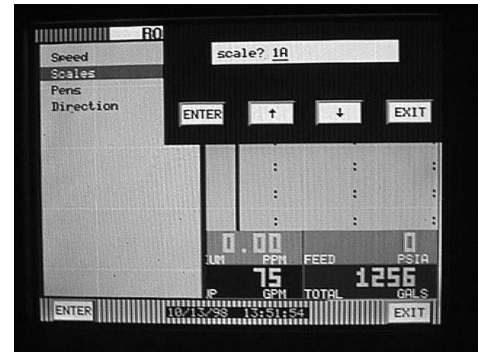

21. The scale setup menu will be displayed. Use the up/down arrow keys to select **Scale ends** and touch **ENTER**.

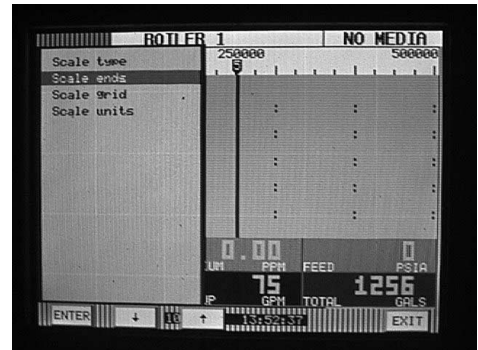

22. You will now be prompted with **places?** (0-5 will also be displayed). Use the up/down arrow keys to select 2 and touch **ENTER**. This selects the number of decimal places that will be displayed in trend view only.

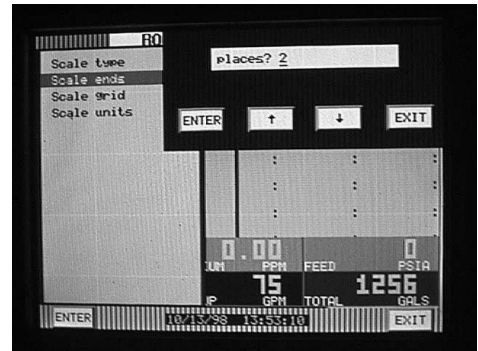

23. You will now be prompted with **lo→** (some #). Enter the low end of your scale. For this example (0-250 psig) enter **0.00** and touch **ENTER**.

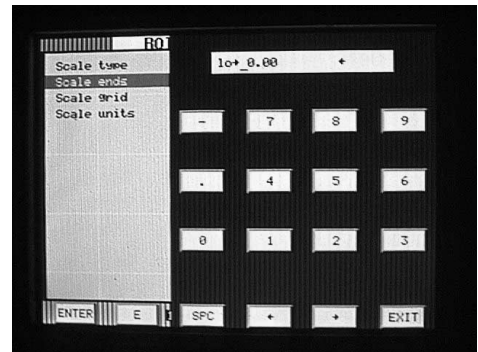

24. You will now be prompted with **mid→** (some #). Here you can enter the mid point of your scales range. For this example (0-250 psig) enter **125.00** and touch **ENTER**.



Appendix A – Configuring a 1-5 Vdc input for a 0-250 psig pressure transducer

25. You will now be prompted with **hi→** (some #). Enter the high range of your scale range. For this example (0-250 psig) enter **250.00** and touch **ENTER**.



26. You will now be back at the scale setup menu. Use the up/down arrow keys to select **Scale units** and touch **ENTER**. The alphanumeric keypad will be displayed. This is what will be displayed as engineering units in the trend mode only. For this example enter **PSIG** and touch **ENTER**.

Touch **EXIT** several times until you are completely out of all menus.

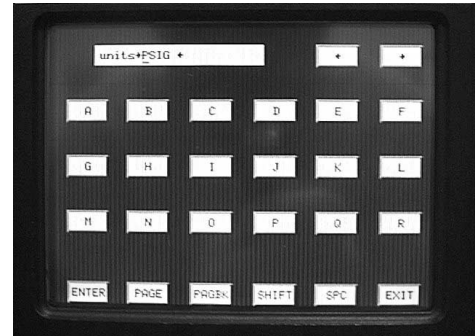

The 0-250 scale complete with **INLET** and **PSIG** should be displayed on the recorder. Use the **VIEW** button to select a particular display to verify your work.

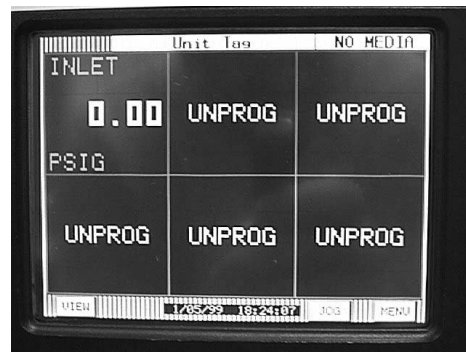
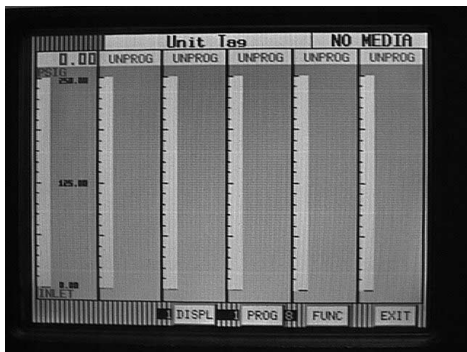



# Appendix B

## Configuring a 4-20 mA input to equal 0 to 150 gpm

1. Begin configuration by touching the **MENU** button in the lower right hand corner of the screen. This will bring up the Command button bar. Touch the **PROG** button to enter into the main program menu.

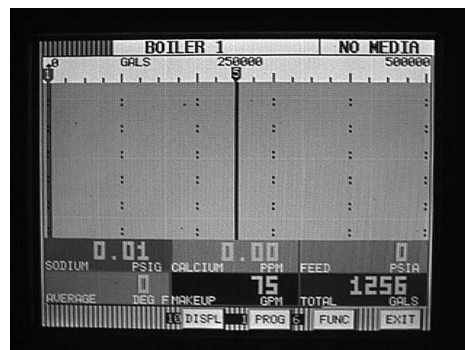

2. Once in the main program menu use the up/down arrow keys to select **Points** and then touch **ENTER**.

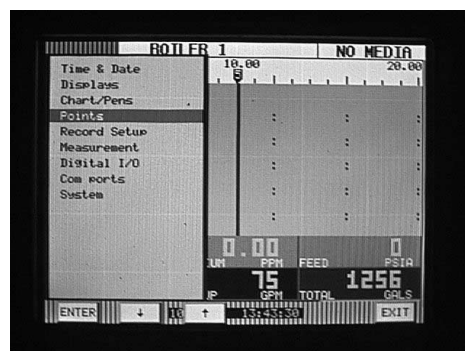

3. **Prog point** and **Constants** will appear. Using the up/down arrow keys select **Prog point** and touch **ENTER**.

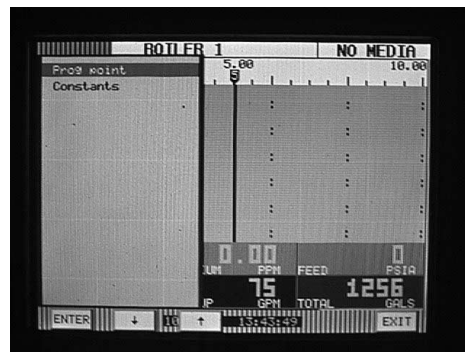

4. The numbers **1-9** and letters **A-F** represent the 15 channels that can be set up. Touch the number or letter that represents the input or channel you wish to configure. For this example use number **1** and touch **ENTER**.

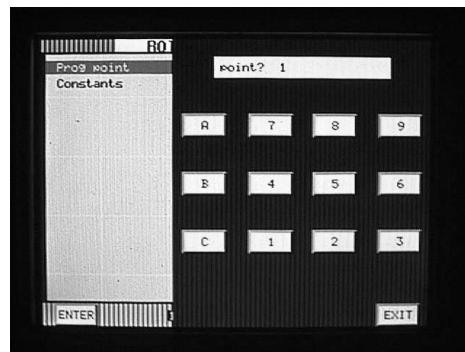

Appendix B – Configuring a 4-20 mA input to equal 0 to 150 gpm

5. If you are configuring the Recorder for the first time, a menu having **Setup pt**, **Copy pt** and **Restore pt** will appear. If you are changing a point that you have already configured, the menu will have **Modify pt** and **Delete pt**. Depending on which menu appears, use the up/down arrow keys to select **Setup pt** or **Modify pt** and then touch **ENTER**.

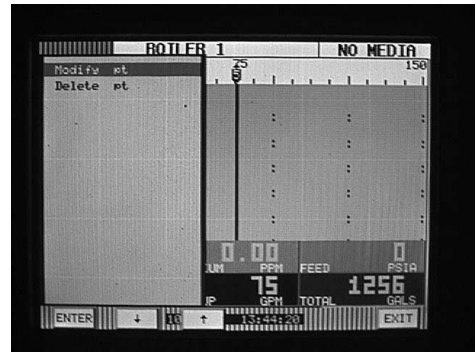

6. The menu containing types of inputs should now be displayed. Use the up/down arrow keys to select **Linear** then touch **ENTER**.

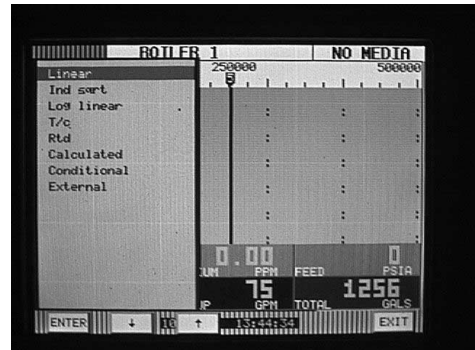

7. The menu displaying types of linear inputs should now appear. For this example use the up/down arrow keys to select **4-20 mA** and touch **ENTER**.

The menu starting with **Point tag** will appear. Using the up/down arrow keys select **Point tag** and touch **ENTER**.

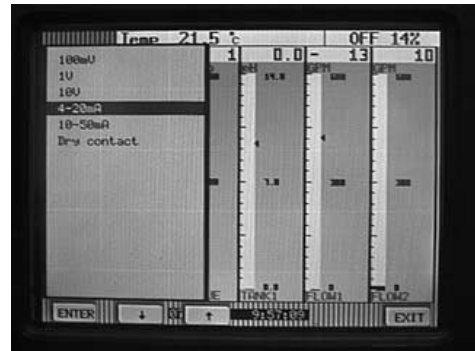

8. An alphanumeric keypad will be displayed. This is where you enter a word or phrase (up to 10 characters\*) that describes this particular point. There are multiple pages of letters, numbers and symbols that can be used. Use the **PAGE**, **PAGEBK** and **SHIFT** keys to access the different characters. For this example enter the word **EFFLUENT** and touch **ENTER**.

\* Only 8 characters will be displayed on the screen although all ten will be recorded and can be displayed using the *Companion Software*.

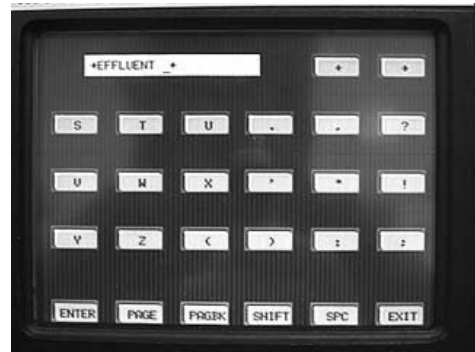

9. The menu starting with **Point tag** will appear again. Using the up/down arrow keys select **Output scale** and touch **ENTER**.

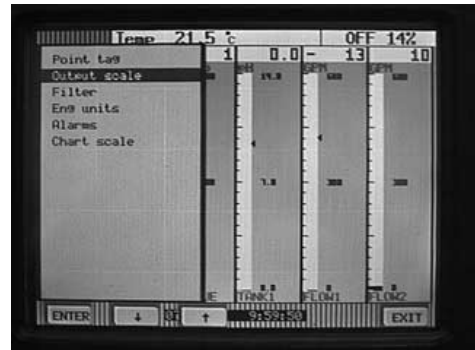

Appendix B – Configuring a 4-20 mA input to equal 0 to 150 gpm

10. A menu prompting you **places?** will appear. Use the up/down arrow keys to select the number of decimal places you wish to be displayed and recorded. For this example select **0** and touch **ENTER**.

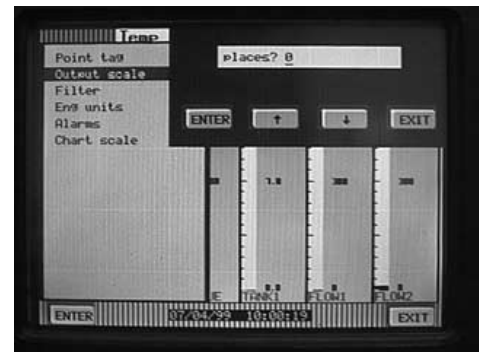

11. A numeric keypad will now be displayed prompting you with **lo→ ←**. This is where you enter the low end of your range or the equivalent value for 4 mA. For this example (0 to 150 gpm) select **0** and touch **ENTER**.



12. You will now be prompted with **hi→ ←**. This is where you enter the high end of your range of the equivalent value for 20 mA. For this example select **150** and touch **ENTER**.

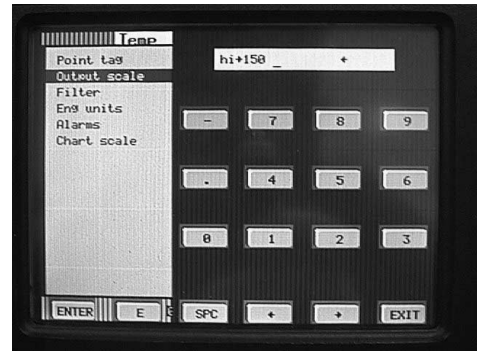

13. Using the up/down arrow keys select **Eng units** and touch **ENTER**. An alpha-numeric keypad will appear prompting you **units→ ←**. You can enter up to 5 characters. Using the **PAGE**, **PAGBK** and **SHIFT** keys, if needed, enter the desired engineering units. For this application enter **GPM** and touch **ENTER**.

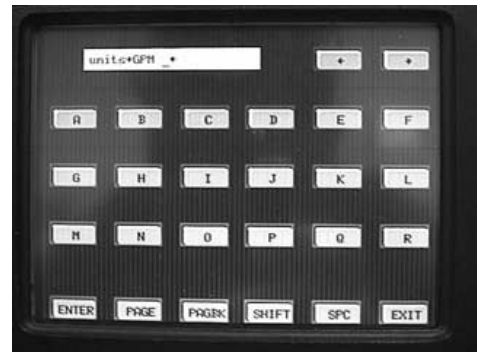

14. You will now be back at the menu beginning with **Point tag**. Using the up/down arrow keys select **Alarms** and touch **ENTER**.

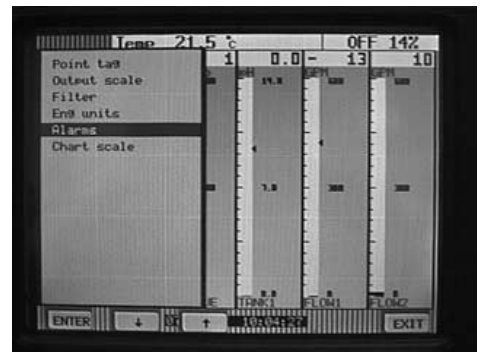

Appendix B – Configuring a 4-20 mA input to equal 0 to 150 gpm

- Using the up/down arrow keys select **Alm limits** and touch **ENTER**.

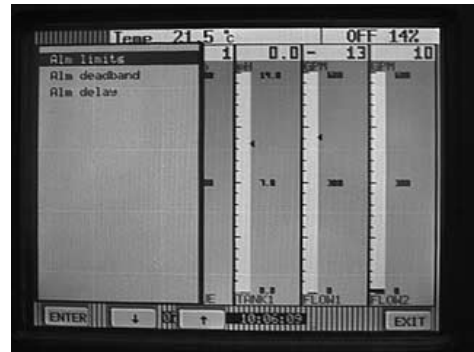

- You will be prompted with **alarm #?**. Each point has 5 internal alarm set points. You can use the up/down arrow keys to scroll through 1, 2, 3, 4, or 5. Since this is the first alarm set point for channel one, select **1** and touch **ENTER**.

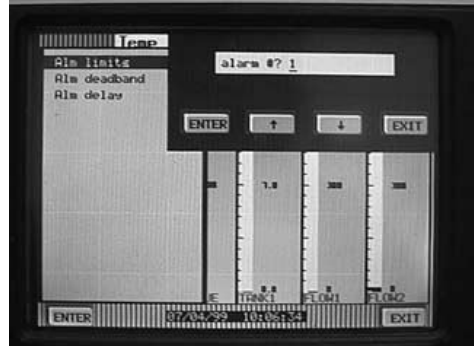

- The alarm types menu will now be displayed. Using the up/down arrow keys you can select the type of alarm you wish to configure. For this example we want to know when the flow exceeds 120 gpm. Select **Type=high** and touch **ENTER**.

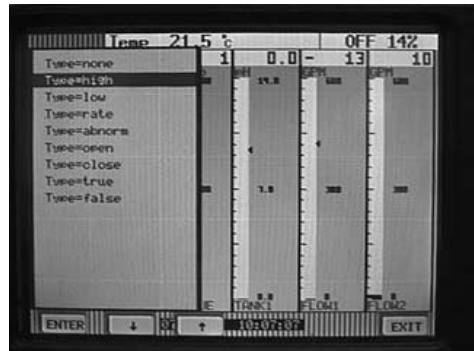

- A numeric keypad will now be displayed prompting you with **high→ ←**. Enter **120** and touch **ENTER**.



- You will next be prompted **contact #?**. If your recorder is fitted with alarm contact outputs, you can select which contact will change state when the internal high alarm activates. Using the up/down arrows you can select 0, 1, 2, 3, 4, 5 or 6. For this example select **2** and touch **ENTER**.

**Note:** If you do not have relays or do not wish to activate a relay, select **0** (0 is the default setting) and touch **ENTER**.

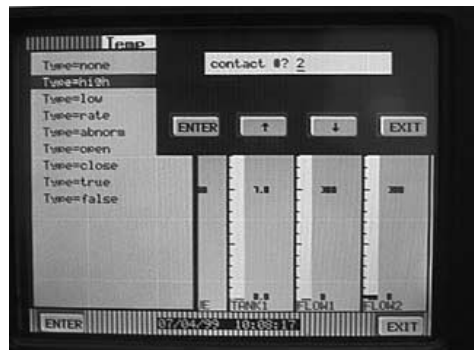

Appendix B – Configuring a 4-20 mA input to equal 0 to 150 gpm

20 Touch **EXIT** twice to get back to the menu beginning with **Point tag**. Using the up/down arrow keys select **Chart scale** and touch **ENTER**. Using the up/down arrows you can select A, B, C, D, E, F, G or H. For this example select **A** and touch **ENTER**.

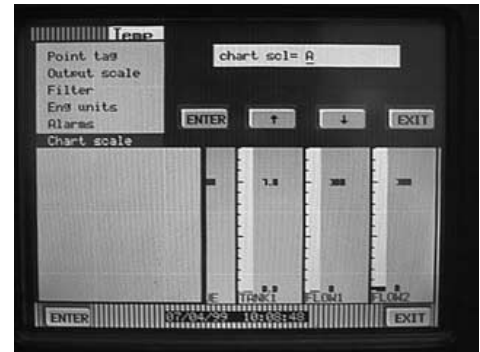

21. Touch **EXIT** to complete configuration of this point and you will be prompted with **keep setup?**. Touch **YES** to permanently save your changes.

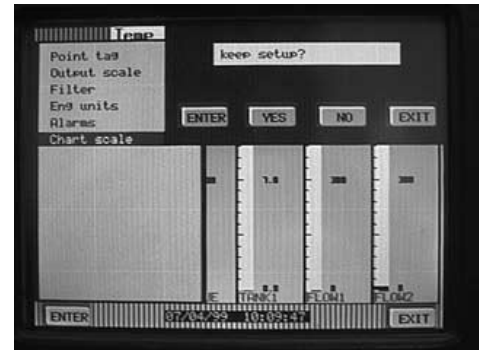

22 You will be back at the main program menu. Using the up/down arrow keys select **Chart/Pens** and touch **ENTER**.



23 You will now be in the Chart/Pens menu beginning with **Speed**. Using the up/down arrow keys select **Scales** and touch **Enter**.

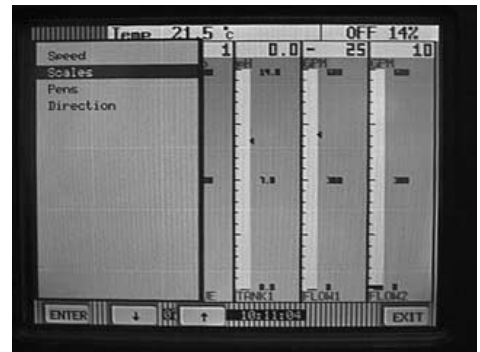

24 You will now be prompted with **Scale?**. Using the up/down arrow keys you can select scales **1A** through **2H**. For this example select **1A** and touch **ENTER**.

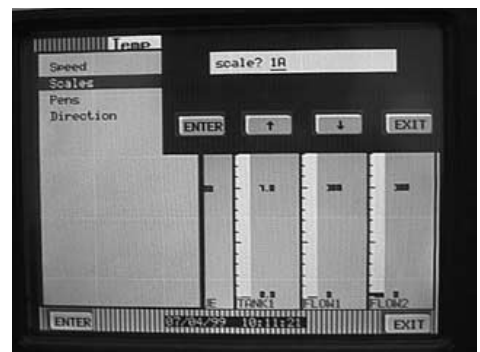

Appendix B – Configuring a 4-20 mA input to equal 0 to 150 gpm

25. Use the up/down arrow keys to select **Scale ends** and touch **ENTER**. You will now be prompted with **places?**. Here you can select the number of decimal places that will be displayed on the virtual chart display. For this example use the up/down arrow keys to select **0** and touch **ENTER**.

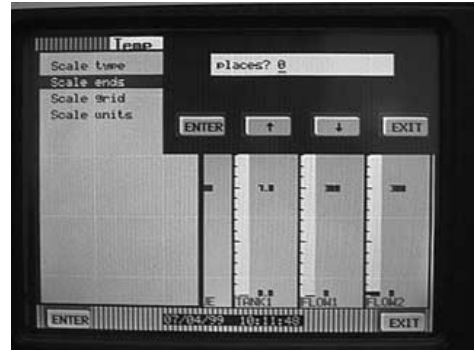

26. You will be prompted with **lo** → ←. Enter the low value of your scale. For this example (0 to 150 gpm) select **0** and touch **ENTER**.

**NOTE:** You do not necessarily have to use the same scale values that you selected in the point setup (0 to 150) you could display/record a smaller portion of your full span, 90 to 150, for instance.



27. You will now be prompted with **mid** → ←. Here you can select the value that will be displayed at 50% of your span. For this example select **75** (which is 50% of our full span, 150) and touch **ENTER**.

**NOTE:** You do not necessarily have to enter the exact half way point of your span. You could enter 30 for instance, where 30 would be exactly half way between 0 and 150. This would give you a high resolution side (0 to 30 gpm) and a lower resolution side (30 to 150 gpm).



28. Finally, you will be prompted with **hi** → ←. Here you enter the high end of your span. For this example select **150** and touch **ENTER**. Then touch **EXIT** several times until you are completely out of all menus.

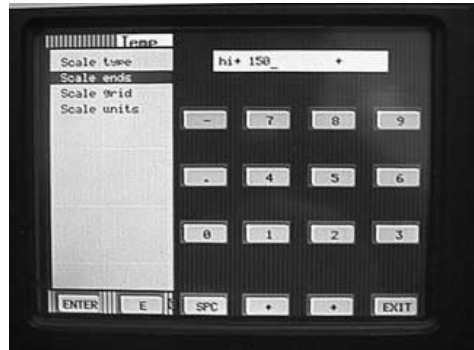

29. The 0-150 scale complete with EFFLUENT and GPM should be displayed on the Recorder. Use the VIEW button to select a particular display to verify your work. You will also notice that your high alarm set point is marked at 120 with an arrow.

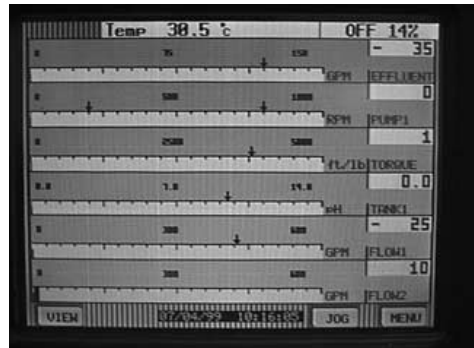

Appendix B – Configuring a 4-20 mA input to equal 0 to 150 gpm

30. The photo below shows the proper connectivity for a 4-20 mA signal. To reduce ambient noise, a properly shielded cable should be used. A 50 ohm precision resistor must be placed across the + and – terminals in parallel with the input signal wires. Also, a jumper must be made between the – and C terminals (refer to Figure 2-7 in Chapter 2).

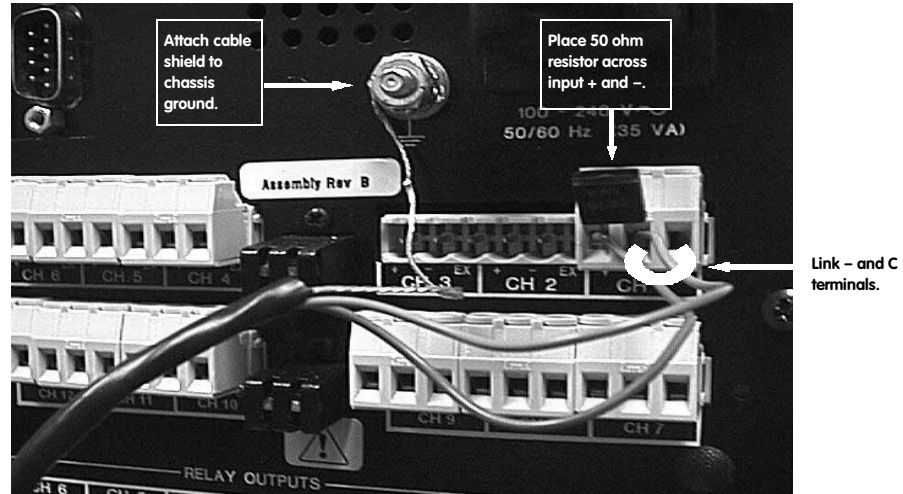

# Appendix C

## Configuring a J type T/C input for a 100 – 750 °C range

1. Begin configuration by touching the **MENU** button in the lower right hand corner of the screen. This will bring up the Command button bar. Touch the **PROG** button to enter into the main program menu.

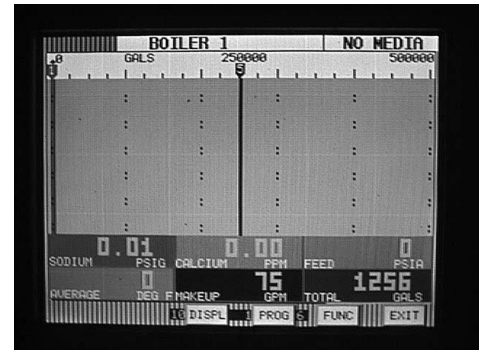

2. Once in the main program menu, use the up/down arrow keys to select **Points**, and then touch **ENTER**.

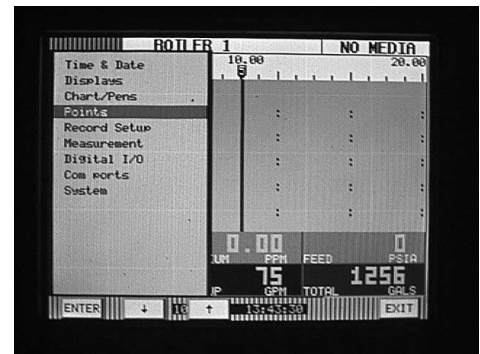

3. **Prog point** and **Constants** will appear. Using the up/down arrow keys select **Prog point** and touch **ENTER**.

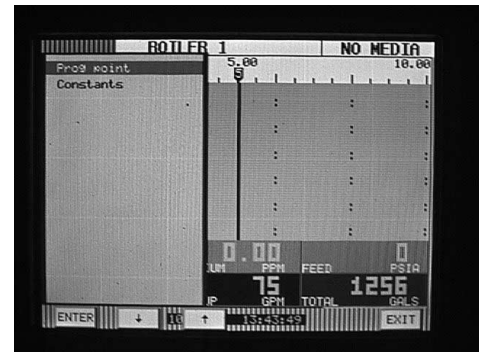

4. The numbers **1-9** and letters **A-F** represent the 15 channels that can be set up. Touch the number or letter that represents the input or channel you wish to configure. For this example use number **1** and touch **ENTER**.

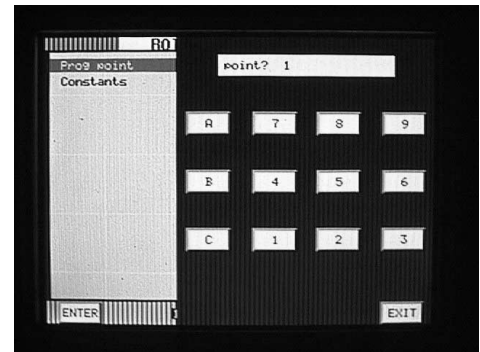



Appendix C – Configuring a J type T/C input for a 100 - 750°C range

5. If you are configuring the Recorder for the first time, a menu having **Setup pt**, **Copy pt** and **Restore pt** will appear. If you are changing a point that you have already configured, the menu will have **Modify pt** and **Delete pt**. Depending on which menu appears, use the up/down arrow keys to select **Setup pt** or **Modify pt** and then touch **ENTER**.

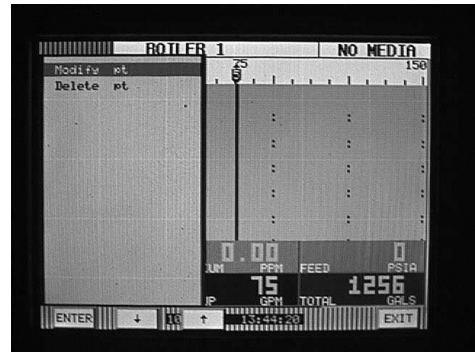

6. The menu containing types of inputs should now be displayed. Use the up/down arrow keys to select **T/c** and then touch **ENTER**.

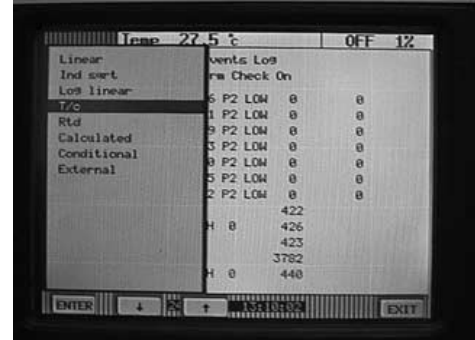

7. The menu displaying thermocouple types should now appear. For this example use the up/down arrow keys to select **J t/c** and then touch **ENTER**.



8. The menu starting with **Point tag** will appear. Using the up/down arrow keys select **Point tag** and touch **ENTER**.

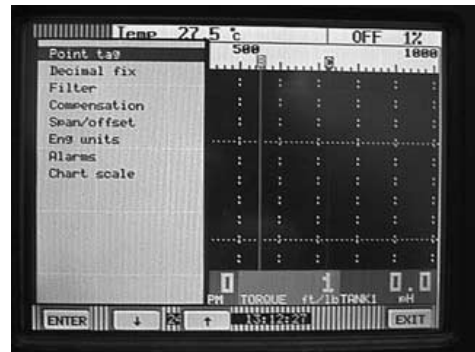

9. An alphanumeric keypad will be displayed. This is where you enter a word or phrase (up to 10 characters\*) that describes this particular point. There are multiple pages of letter, numbers and symbols that can be used. Use the **PAGE**, **PAGEBK** and **SHIFT** keys to access the different characters. For this example enter **J t/c** and touch **ENTER**.

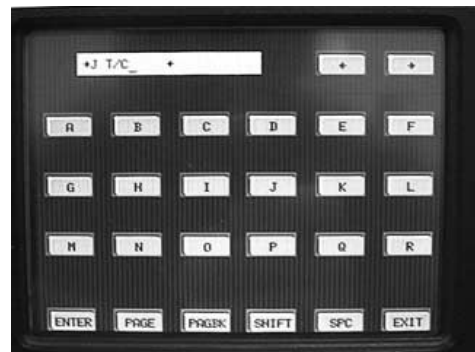

\* Only 8 characters will be displayed on the screen although all ten will be recorded and can be displayed using the *Companion Software*.

Appendix C – Configuring a J type T/C input for a 100 - 750°C range

- The menu starting with **Point tag** will again be displayed. Use the up/down arrow keys to select **Decimal fix** and touch **ENTER**. You will be prompted with **places>?** (0 or 1). Use the up/down arrows to select zero or one decimal place for thermocouples. For this example select **1** and touch **ENTER**.

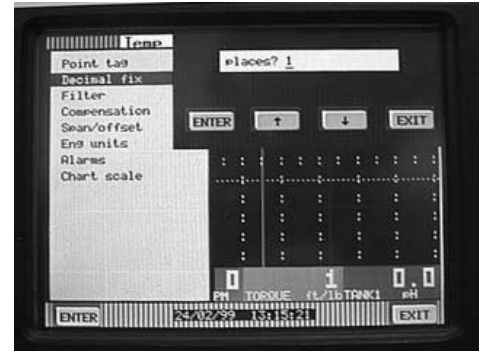

- You will now be back at the menu starting with **Point tag**. Use the up/down arrow keys to select **Compensation** and touch **ENTER**. Use the up/down arrow keys to select **Local comp** and touch **ENTER**. The Recorder will now use a temperature sensor located at the rear of the recorder to correct for cold junction error. You must touch **EXIT** to leave this menu.

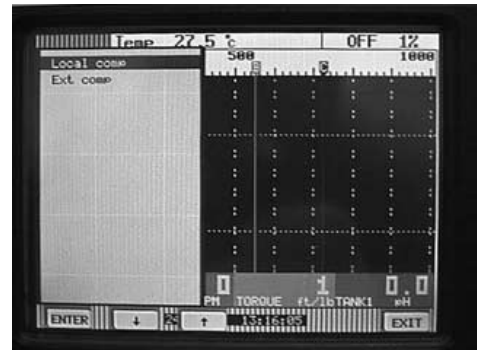

- You should now be back at the **Point tag** menu. Use the up/down arrow keys to select **Eng units** and touch **ENTER**. You will be prompted with **units** (°C or °F). For this example use the up/down arrow keys to select **°C** and touch **ENTER**.

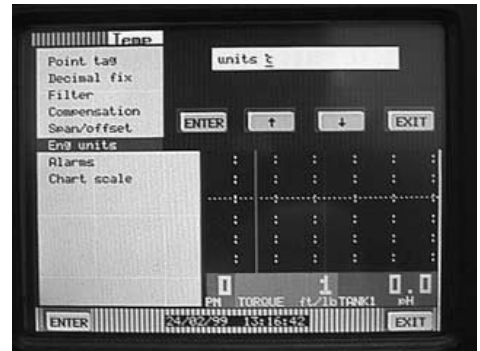

- You will again be in the **Point tag** menu. Use the up/down arrow keys to select **Chart scale** and touch **ENTER**. You will be prompted with **chart scl=**. Use the up/down arrow keys to select **A** and touch **ENTER**. Now touch **EXIT**. You will be prompted with **keep setup?**. Touch **YES** and you will be returned to the main programming menu.

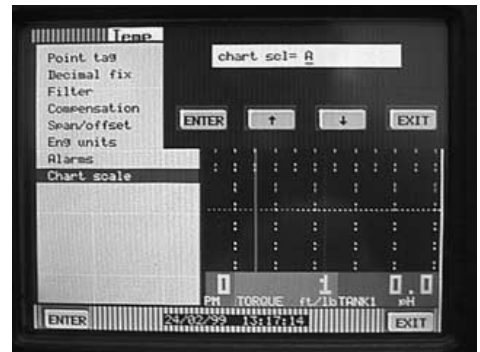

- Use the up/down arrow keys to select **Chart/Pens** and touch **ENTER**.

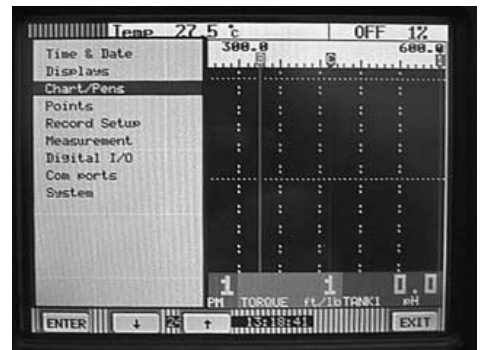

Appendix C – Configuring a J type T/C input for a 100 - 750°C range

- Use the up/down arrow keys to select **Scales** and touch **ENTER**. You will be prompted **scale?**. Use the up/down arrow keys to select **1A** and touch **ENTER**.

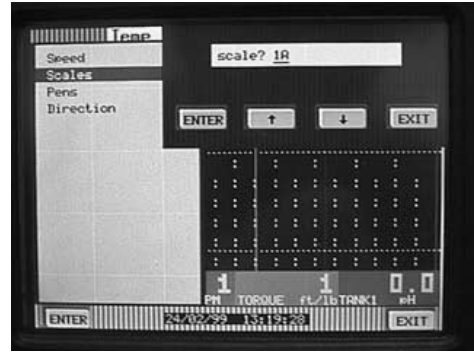

- You will now be in the scale menu. Use the up/down arrow keys to select **Scale ends** and touch **ENTER**. You will be prompted with **places?** (for decimal places). Using the up/down arrow keys you can select 0, 1, 2, 3, 4 or 5. For thermocouples you would only select 0 or 1. For this example select **1** and touch **ENTER**.



- You will be prompted with **lo** → ←. For this example (100 to 750 °C) enter **100** for the low range of your scale and touch **ENTER**.



- You will now be prompted with **mid** → ←. To illustrate one of the features of the Recorder we will enter a value that is not 50% of the desired range. For this example, enter **200** and touch **ENTER**. The result will be two linear ranges. One will have high resolution and the other will have low resolution.

**Note:** If you wanted the scale to be linear you would simply enter the exact middle of your range at this point.



- The next prompt will be **hi** → ←. For this example enter **750** and touch **ENTER**. You will now be back in the main scale menu. Use the up/down arrow keys to select **Scale units** and touch **ENTER**.



Appendix C – Configuring a J type T/C input for a 100 - 750°C range

- 20 An alphanumeric screen will appear and you can enter **C** or **DEG C**. What you choose to enter in this screen will be displayed as the engineering units in the trend view only. After entering your selection touch **ENTER**. Touch **EXIT** several times until you are completely out of all menus.



21. You have now successfully configured your thermocouple input with a non linear scale. The display will read as shown on the right. TCBO (thermocouple burnout) will be displayed until your thermocouple is connected to the rear of the unit.



# Appendix D

## Configuring the Totalizer

1. Before setting up a math channel for totalization, you must first have a "base" channel configured from which the totalizer gets its information (i.e. a channel receiving a signal from a flow meter that is proportional to flow rate).

For this example we will configure math channel A to be the totalizer. Channel 1 is already configured as the flow rate channel receiving a 4-20 mA signal from an open channel flow meter (see Appendix B for setting up a 4-20 mA input). The flow rate is 0 to 50 MGD (million gallons/day).

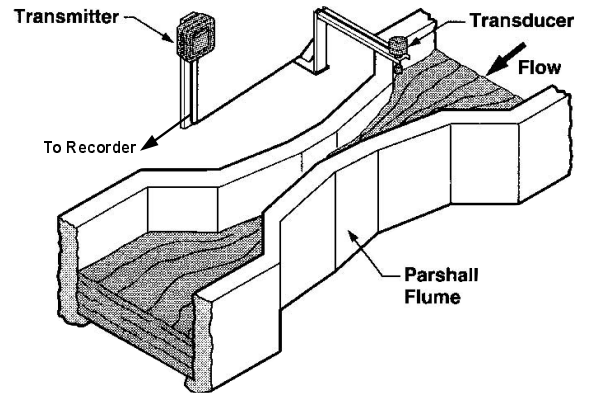

2. Once in the main program menu use the up/down arrow keys to select **Points**, then touch **ENTER**.

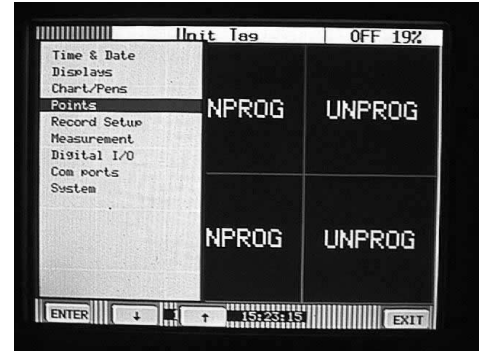

3. **Prog point** and **Constants** will appear. Using the up/down arrow keys select **Prog point** and touch **ENTER**.

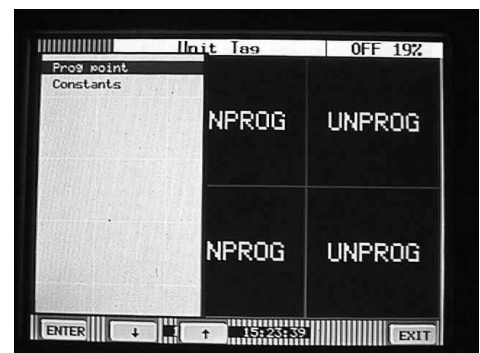

4. The numbers **1-9** and letters **A-F** will be displayed. **Channel A-F must be used for totalization channels** as these channels will hold the total value in the event of a power outage. (Channels 1-9 will not; they will reset.) For this example select **A** and touch **ENTER**.

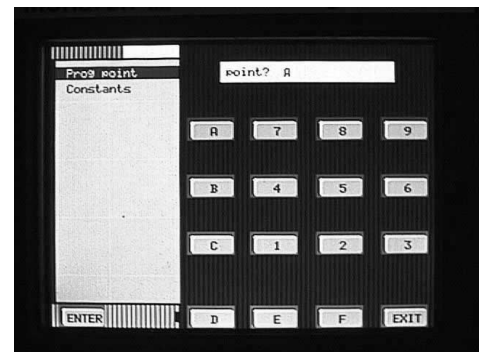

Appendix D – Configuring the Totalizer

- If you are configuring the Recorder for the first time, a menu having **Setup pt**, **Copy pt** and **Restore pt** will appear. If you are changing a point that you have already configured, the menu will have **Modify pt** and **Delete pt**. Depending on which menu appears, use the up/down arrow keys to select **Setup pt** or **Modify pt** and then touch **ENTER**.

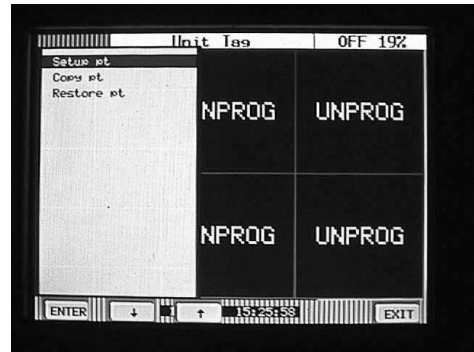

- The menu containing types of inputs should now be displayed. Use the up/down arrow keys to select **Calculated** and then touch **ENTER**.

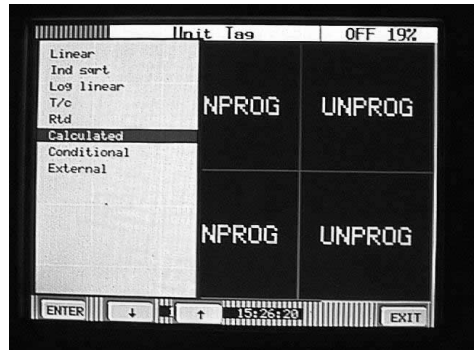

- The menu displaying the various calculated channel types should now appear. For this example use the up/down arrow keys to select **Totalize** and then touch **ENTER**.

The menu starting with **Point tag** will appear. Using the up/down arrow keys select **Point tag** and touch **ENTER**.

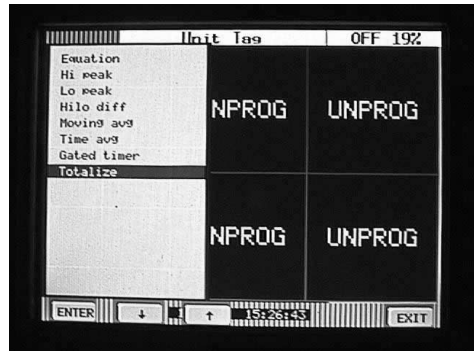

- An alphanumeric keypad will be displayed. This is where you enter a word or phrase (up to 10 characters\*) that describes this particular point. There are multiple pages of letters, numbers and symbols that can be used. Use the **PAGE**, **PAGEBK** and **SHIFT** keys to access the different characters. For this example enter the word **TOTAL** and touch **ENTER**.

\* Only 8 characters will be displayed on the screen although all ten will be recorded and can be displayed using the *Companion Software*.

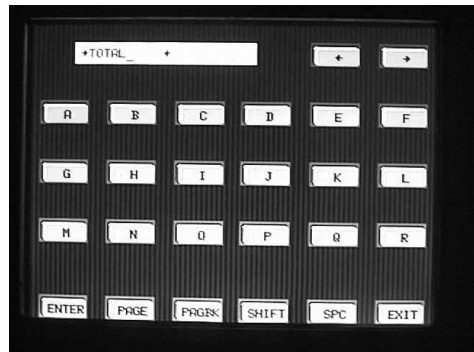

- The menu starting with **Point tag** will again be displayed. Use the up/down arrow keys to select **Decimal fix** and touch **ENTER**.

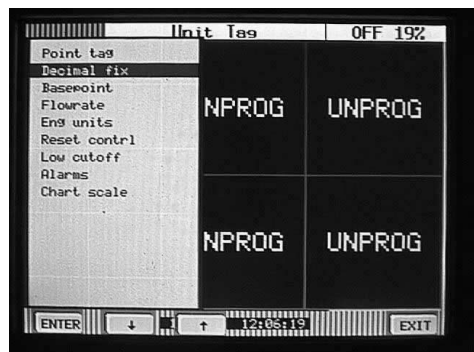

Appendix D – Configuring the Totalizer

- You will be prompted with **places>?** (0, 1, 2, 3, 4 or 5). Using the up/down arrows you may select the appropriate number of decimal places. For this example select **1** and touch **ENTER**.

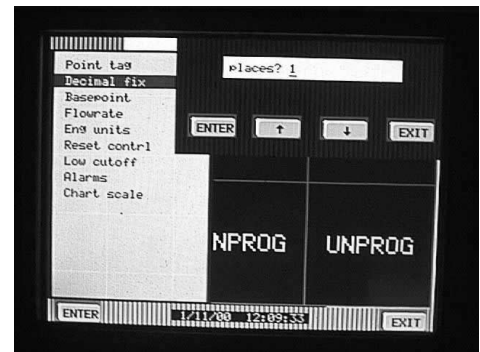

- You will now be back at the menu starting with **Point tag**. Use the up/down arrow keys to select **Basepoint** and touch **ENTER**. You will be prompted with **base pt?**. Use the up/down arrow keys to select the channel from which the totalizer will derive its information. For this example, select channel **1** and touch **ENTER**.

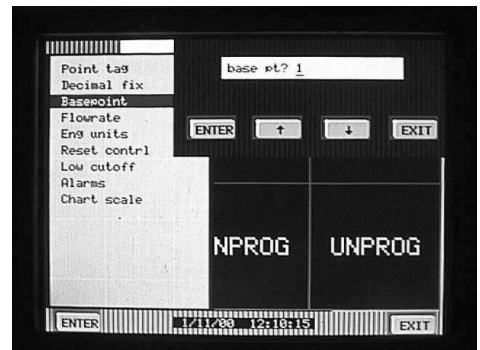

- You should now be back at the **Point tag** menu. Use the up/down arrow keys to select **Flowrate** and touch **ENTER**.

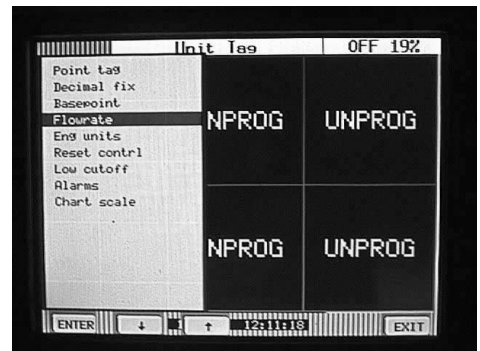

- The menu displaying the various flow rates should appear. Use the up/down arrow keys to select the rate that matches that of your flow meter. In this example our flow meter on channel one measures millions of gallons per day, so select **flow= /day** and touch **ENTER**. You will have to touch **EXIT** to leave this menu.

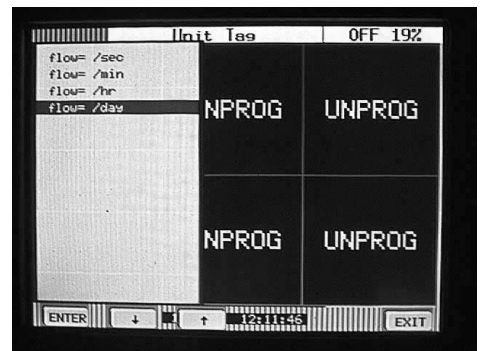

- You will again be back at the **Point tag** menu. Use the up/down arrow keys to select **Eng units** and touch **ENTER**.

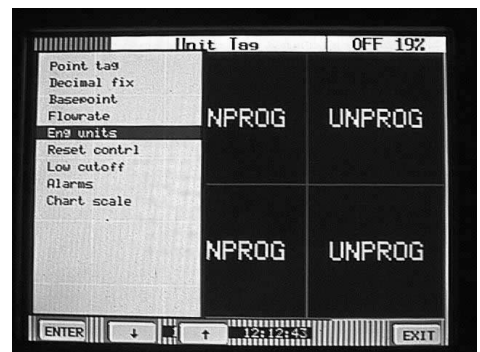

Appendix D – Configuring the Totalizer

- The alphanumeric keypad should now appear allowing you to enter up to 5 characters to describe the engineering units for this particular point. There are multiple pages of letters, numbers and symbols that can be used. Use the **PAGE**, **PAGEBK** and **SHIFT** keys to access different characters. For this example enter **MG** (for million gallons) and touch **ENTER**.

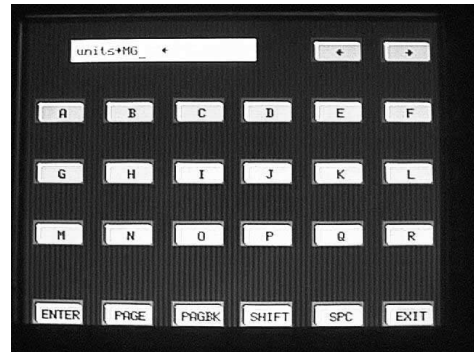

- You will now be back at the Point tag menu. Use the up/down arrow keys to select **Reset contrl** and touch **ENTER**.

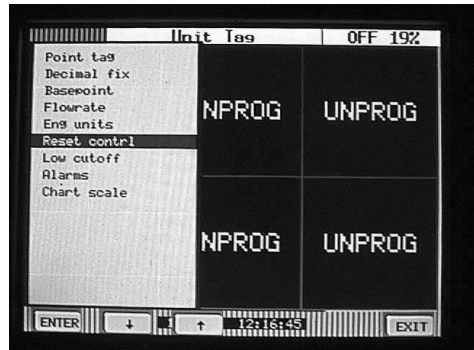

- You will now be in the Reset Control menu. Use the up/down arrow keys to select **Auto reset** and touch **ENTER**.

The menu containing Auto reset options will appear. For this example we would like daily totals, so use the up/down arrow keys to select **Daily** and touch **ENTER**.

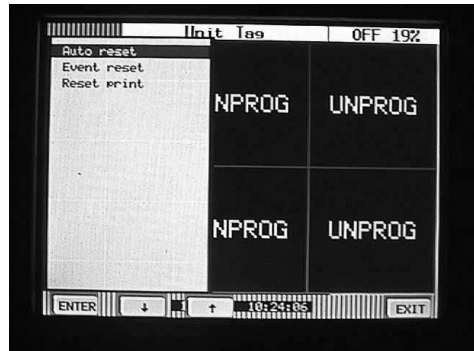

- You will now be prompted with **start 00:00**. This is the time (24 hour format) that you would like the totalizer to begin. Leave the number at **00:00** to signify that you would like to start totalizing at 12:00 am by just touching **ENTER**.

**Note:** The Auto reset menu allows you to program the Recorder to reset the totalizer automatically at a desired time interval. If you choose Auto off, the totalizer will not reset unless done so manually.

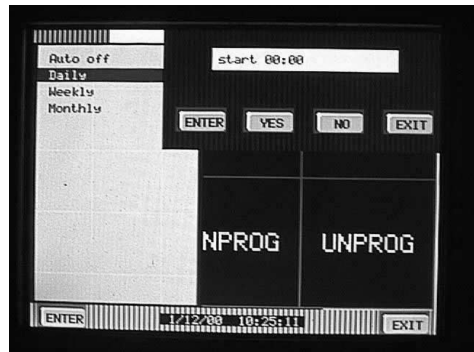

- You will now be prompted with **intrvl 01:00**. This is the time interval you would like to have the totalizer reset. You can choose from one minute to 24 hours. Touch **NO**. You will be prompted **int hrs →1 ←**. Using the numeric keypad, enter **24** and touch **ENTER**. Then touch **EXIT**.

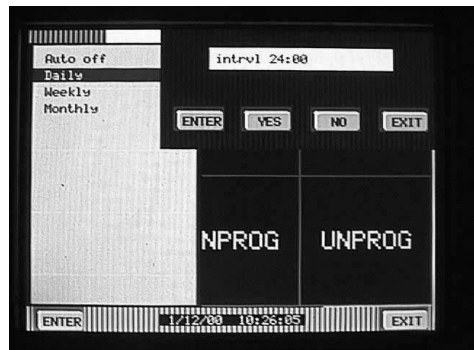



Appendix D – Configuring the Totalizer

20. You will now be back at the Reset Control menu. Use the up/down arrow keys to select **Reset print** and touch **ENTER**. You will be prompted with **print=NO\***. Touch the **YES** key then touch **ENTER**. This enables the Recorder to post the totalizer reset information to the alarm/event page which is where you would view your daily totals.

Touch **EXIT** to get back to the menu beginning with **Point tag**.

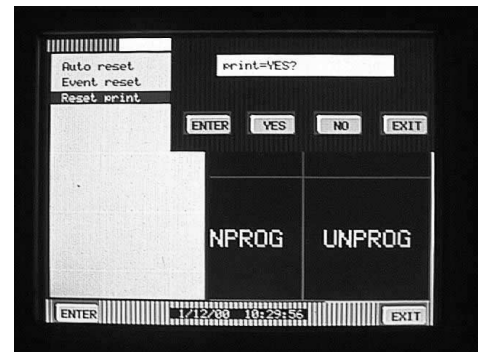

21. Use the up/down arrow keys to select **Low cutoff** and touch **ENTER**. You will be prompted with **cut→ 0.0 ←**. This feature allows you to enter a minimum flow rate at which the totalizer should cut out and stop totalizing. This is for transmitters that become very inaccurate at low flow rates. Since ours is an open channel meter, we will not program a low cutoff. Leave it set at **0.0** and touch **ENTER**.

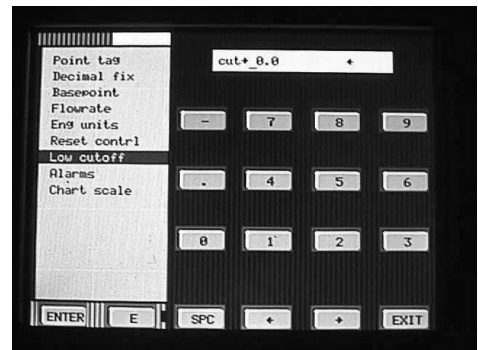

22. You should now be back in the menu beginning with **Point tag**. Use the up/down arrow keys to select **Chart scale** and touch **ENTER**. You will be prompted with **chart scl= A**. Use the up/down arrow keys to select **A** and touch **ENTER**.

**Note:** Since the range of the flow meter is 0-50 MGD and we will only be totalizing for a maximum of one day, the totalizer will not exceed 50 so we can use the same scale. If we were totalizing over long periods of time, we would have to put in an appropriate scale for the totalizer channel.



23. Touch **EXIT**. You will be prompted **keep setup?**. Touch **YES** and you will be returned to the main program menu. Touch **EXIT** several times until you are completely out of all menus.

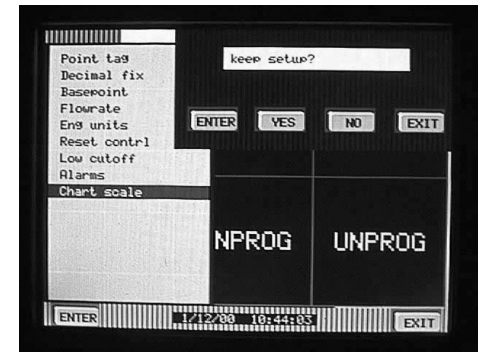

24. You have now successfully configured a totalization channel! Use the **VIEW** button to select a particular display to verify your work.

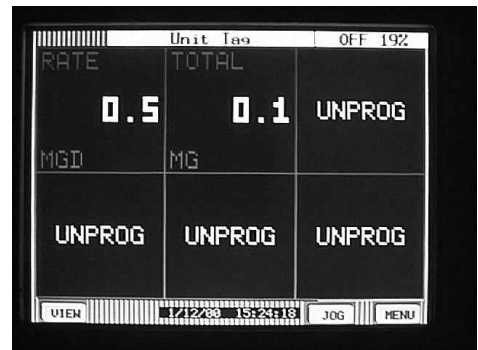

# Appendix E

## Setting the Jumpers for the 3 or 6 Channel Mechanical or Solid State Relay

**WARNING:** Due to hazardous voltages on the Rear Terminal Panel, use extreme caution when installing or servicing your instrument. Please read the entire contents of the Installation and Wiring Chapter before attempting to install or service your instrument.

**WARNING:** Before attempting to remove the unit from the panel, opening the front or working on the back of the instrument, ensure that the AC mains to the unit is **SWITCHED OFF** and **REMOVE THE POWER CORD** from the socket on the rear panel. Ensure that all live connections to the rear panel terminals are **ISOLATED** before removing the wiring.



### Set Jumpers

The opto-isolated inputs require an external potential of 5 to 12 Volts DC @ 10mAmps by default. To activate the inputs via potential free contacts (contact closure), jumpers need to be set as described below:

1. Remove the circuit board from the rear panel (See Figure 1).

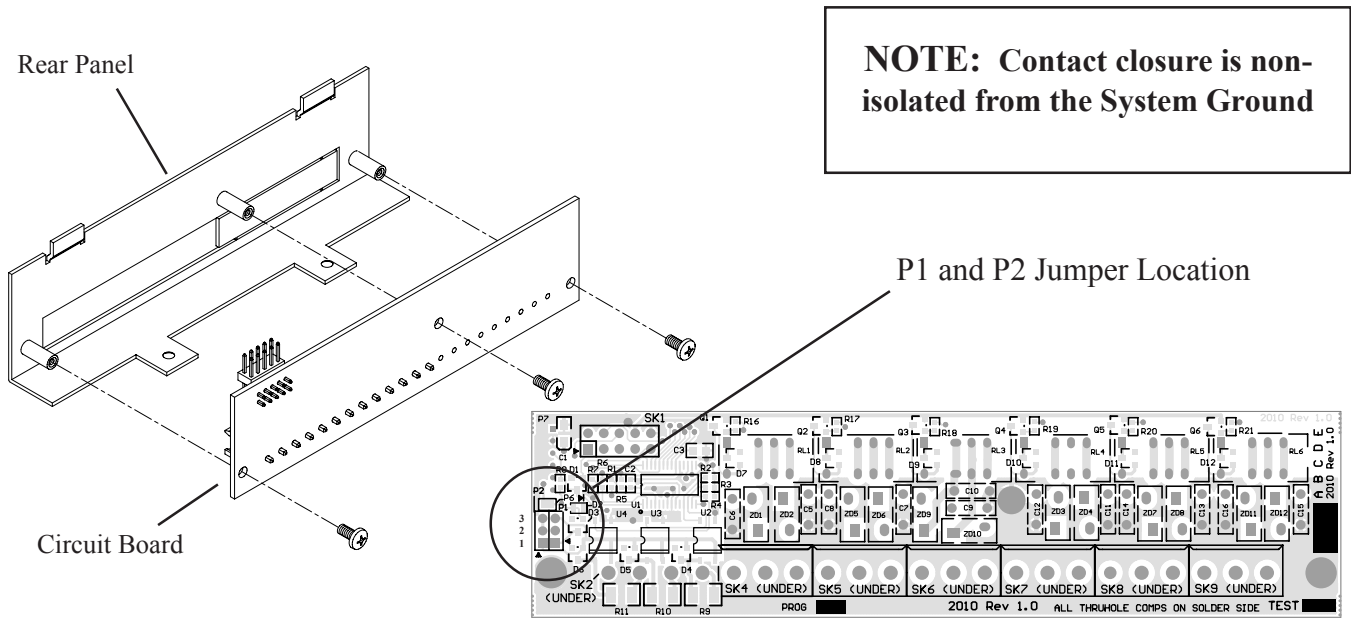

**Figure 1 Jumper Location (Mechanical Relay shown - The jumpers for the Solid State Relay are in the same location.)**

2. Set the jumpers according to Table 1:

	Mechanical Relay (2010 Rev 1.0 and higher)		Solid State Relay (2011 Rev 1.2 and higher)	
	P1	P2	P1	P2
Isolated Input 0-5 Vdc (Default)	Link 2 - 3	Link 2 - 3	Link 1 - 2	No Link
Non-Isolated Contact Closure	Link 1 - 2	Link 1 - 2	Link 2 - 3	Link 1 - 2

**Table 1 Jumper Positions**

3. Screw the circuit board back onto the rear panel.

## Install Relay Option

To install the 3 or 6 Channel Mechanical or Solid State Relay Option into the DIN Standard [144 mm x 144 mm] Data Recorder:

1. Unplug the recorder.
2. Plug the connector and metal tabs of the Relay option into the recorder case as shown in Figure 2.
3. Install two #4-40 x 1/4 flat head screws as shown below to secure the Relay option.
4. Plug the recorder in. The unit will automatically recognize the addition of the Relay option.

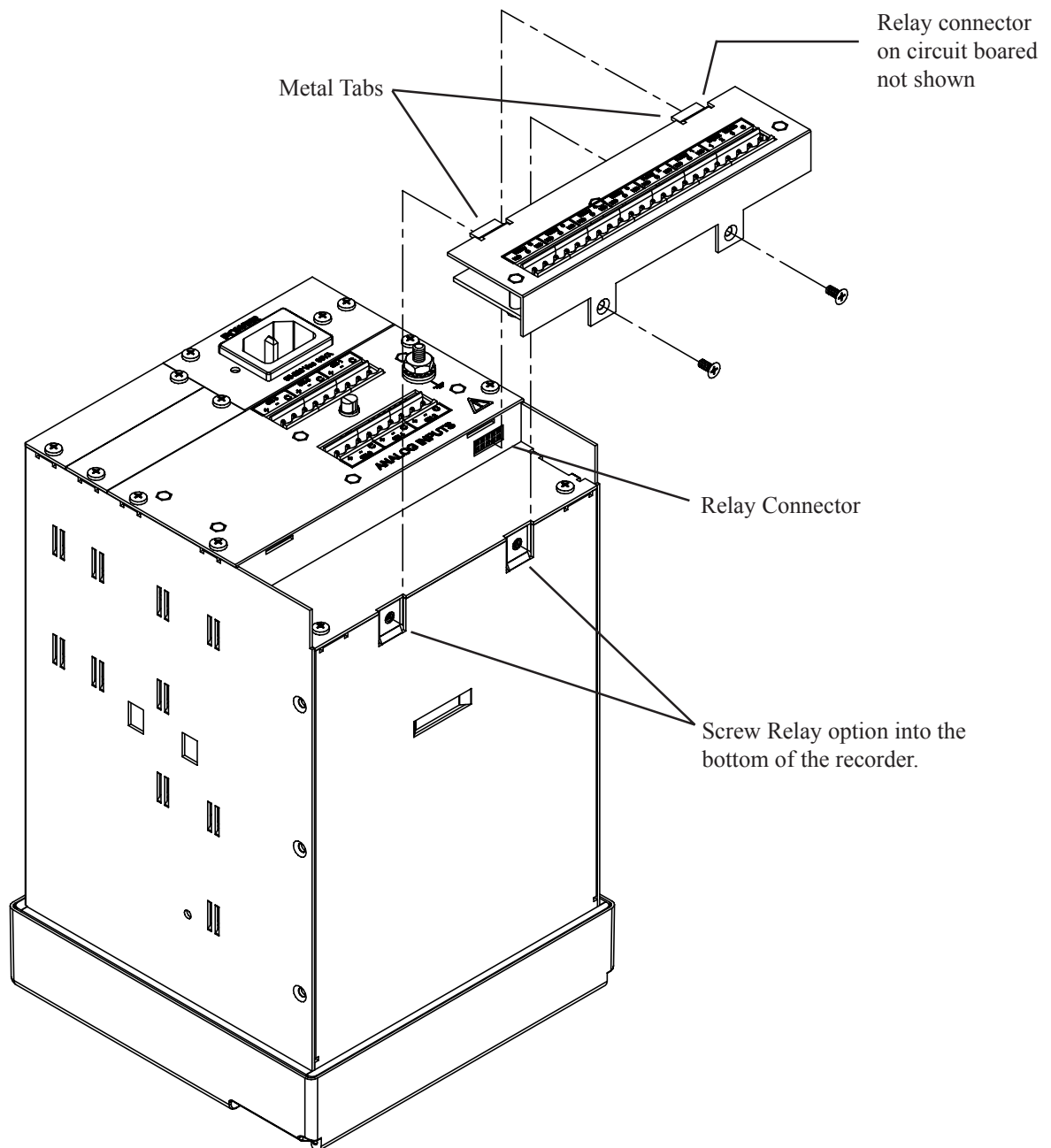

Figure 2 Relay Board Installation



## WARRANTY/DISCLAIMER

OMEGA ENGINEERING, INC. warrants this unit to be free of defects in materials and workmanship for a period of **25 months** from date of purchase. OMEGA's WARRANTY adds an additional one (1) month grace period to the normal **two (2) year product warranty** to cover handling and shipping time. This ensures that OMEGA's customers receive maximum coverage on each product.

If the unit malfunctions, it must be returned to the factory for evaluation. OMEGA's Customer Service Department will issue an Authorized Return (AR) number immediately upon phone or written request. Upon examination by OMEGA, if the unit is found to be defective, it will be repaired or replaced at no charge. OMEGA's WARRANTY does not apply to defects resulting from any action of the purchaser, including but not limited to mishandling, improper interfacing, operation outside of design limits, improper repair, or unauthorized modification. This WARRANTY is VOID if the unit shows evidence of having been tampered with or shows evidence of having been damaged as a result of excessive corrosion; or current, heat, moisture or vibration; improper specification; misapplication; misuse or other operating conditions outside of OMEGA's control. Components which wear are not warranted, including but not limited to contact points, fuses, and triacs.

**OMEGA is pleased to offer suggestions on the use of its various products. However, OMEGA neither assumes responsibility for any omissions or errors nor assumes liability for any damages that result from the use of its products in accordance with information provided by OMEGA, either verbal or written. OMEGA warrants only that the parts manufactured by it will be as specified and free of defects. OMEGA MAKES NO OTHER WARRANTIES OR REPRESENTATIONS OF ANY KIND WHATSOEVER, EXPRESS OR IMPLIED, EXCEPT THAT OF TITLE, AND ALL IMPLIED WARRANTIES INCLUDING ANY WARRANTY OF MERCHANTABILITY AND FITNESS FOR A PARTICULAR PURPOSE ARE HEREBY DISCLAIMED. LIMITATION OF LIABILITY: The remedies of purchaser set forth herein are exclusive, and the total liability of OMEGA with respect to this order, whether based on contract, warranty, negligence, indemnification, strict liability or otherwise, shall not exceed the purchase price of the component upon which liability is based. In no event shall OMEGA be liable for consequential, incidental or special damages.**

CONDITIONS: Equipment sold by OMEGA is not intended to be used, nor shall it be used: (1) as a "Basic Component" under 10 CFR 21 (NRC), used in or with any nuclear installation or activity; or (2) in medical applications or used on humans. Should any Product(s) be used in or with any nuclear installation or activity, medical application, used on humans, or misused in any way, OMEGA assumes no responsibility as set forth in our basic WARRANTY/DISCLAIMER language, and, additionally, purchaser will indemnify OMEGA and hold OMEGA harmless from any liability or damage whatsoever arising out of the use of the Product(s) in such a manner.

## RETURN REQUESTS/INQUIRIES

Direct all warranty and repair requests/inquiries to the OMEGA Customer Service Department. BEFORE RETURNING ANY PRODUCT(S) TO OMEGA, PURCHASER MUST OBTAIN AN AUTHORIZED RETURN (AR) NUMBER FROM OMEGA'S CUSTOMER SERVICE DEPARTMENT (IN ORDER TO AVOID PROCESSING DELAYS). The assigned AR number should then be marked on the outside of the return package and on any correspondence.

The purchaser is responsible for shipping charges, freight, insurance and proper packaging to prevent breakage in transit.

FOR **WARRANTY** RETURNS, please have the following information available BEFORE contacting OMEGA:

1. Purchase Order number under which the product was PURCHASED,
2. Model and serial number of the product under warranty, and
3. Repair instructions and/or specific problems relative to the product.

FOR **NON-WARRANTY** REPAIRS, consult OMEGA for current repair charges. Have the following information available BEFORE contacting OMEGA:

1. Purchase Order number to cover the COST of the repair,
2. Model and serial number of the product, and
3. Repair instructions and/or specific problems relative to the product.

OMEGA's policy is to make running changes, not model changes, whenever an improvement is possible. This affords our customers the latest in technology and engineering.

OMEGA is a registered trademark of OMEGA ENGINEERING, INC.

© Copyright 2003 OMEGA ENGINEERING, INC. All rights reserved. This document may not be copied, photocopied, reproduced, translated, or reduced to any electronic medium or machine-readable form, in whole or in part, without the prior written consent of OMEGA ENGINEERING, INC.

# Where Do I Find Everything I Need for Process Measurement and Control? **OMEGA...Of Course!**

*Shop online at [www.omega.com](http://www.omega.com)*

## **TEMPERATURE**

- ☑ Thermocouple, RTD & Thermistor Probes, Connectors, Panels & Assemblies
- ☑ Wire: Thermocouple, RTD & Thermistor
- ☑ Calibrators & Ice Point References
- ☑ Recorders, Controllers & Process Monitors
- ☑ Infrared Pyrometers

## **PRESSURE, STRAIN AND FORCE**

- ☑ Transducers & Strain Gages
- ☑ Load Cells & Pressure Gages
- ☑ Displacement Transducers
- ☑ Instrumentation & Accessories

## **FLOW/LEVEL**

- ☑ Rotameters, Gas Mass Flowmeters & Flow Computers
- ☑ Air Velocity Indicators
- ☑ Turbine/Paddlewheel Systems
- ☑ Totalizers & Batch Controllers

## **pH/CONDUCTIVITY**

- ☑ pH Electrodes, Testers & Accessories
- ☑ Benchtop/Laboratory Meters
- ☑ Controllers, Calibrators, Simulators & Pumps
- ☑ Industrial pH & Conductivity Equipment

## **DATA ACQUISITION**

- ☑ Data Acquisition & Engineering Software
- ☑ Communications-Based Acquisition Systems
- ☑ Plug-in Cards for Apple, IBM & Compatibles
- ☑ Datalogging Systems
- ☑ Recorders, Printers & Plotters

## **HEATERS**

- ☑ Heating Cable
- ☑ Cartridge & Strip Heaters
- ☑ Immersion & Band Heaters
- ☑ Flexible Heaters
- ☑ Laboratory Heaters

## **ENVIRONMENTAL MONITORING AND CONTROL**

- ☑ Metering & Control Instrumentation
- ☑ Refractometers
- ☑ Pumps & Tubing
- ☑ Air, Soil & Water Monitors
- ☑ Industrial Water & Wastewater Treatment
- ☑ pH, Conductivity & Dissolved Oxygen Instruments