

# **READ ME FIRST**

**TECHNICAL SUPPORT  
1-800-FORD-KEY  
CANADIAN DEALERS  
BILINGUAL FRENCH/ENGLISH  
TECHNICAL SUPPORT  
(514)973-2846**

For convenience this document uses short names when referring to a particular system or kit. The list below identifies the short names used herein:  
Remote Start System —> **RMST**

Navigating this document can be accomplished by: 1) using the buttons in the Acrobat toolbar or 2) clicking on the bookmark links in the bookmark pane to the left. (Clicking on the (+) symbols next to a bookmark will expand that bookmark, revealing additional selections).

This installation instruction covers the installation of all Remote Start Kits.

**Vehicle wiring is subject to change. All possible efforts have been taken to ensure that the information contained herein is accurate as of the revision dates indicated. As such, it is critical that vehicle circuits are tested prior to making any connections, to ensure that the proper vehicle circuit has been located.**

Prior to beginning this installation it is recommended that you lower the driver's door window to prevent locking the keys in the vehicle.

Prior to beginning your first installation of this product it is recommended that you:

- 1 Thoroughly review and print out the instructions;
- 2 Review the reference section to become acquainted with the additional information that is available.
- 3 Go through the vehicle specific wiring and use as a reference during the installation.
- 4 Review the installation video on the Ford Genuine Accessory website that is located with the RMST Installation Instructions.

## Ford Accessory Vehicle Security, Keyless Entry and Remote Start Warranty Return Procedures

### **DO NOT CLAIM PARTS WARRANTY ON FORM 1863**

#### Parts Warranty Processing:

Lifetime limited coverage to original purchaser on all components against defects and workmanship. (For complete Warranty details, please refer to the warranty section found at the rear of each Security or Remote Start systems Owners Manual) Contact the warrantor, Code Systems for return authorization/replacement approval for failed components at no charge by the manufacturer. Return of Components to Code Systems requires the following:

1. Dealer/FAD representative must call the Ford Vehicle Security System Dealer Warranty Department at 1-800-FORDKEY (1-800-367-3539) to obtain generic claim form.
2. Fill out claim form and identify the defective component, **not the entire kit**, and fax to 1-631-231-5785.
3. Dealer/FAD will receive via fax the claim form with RA number authorizing the return of defective components.
4. Dealer/FAD is to box the defective component (including a copy of the claim form) with the claim number clearly written on the package(s) and ship them freight pre-paid to:

Ford Service Parts  
180 Marcus Blvd.  
Hauppauge, NY 11788









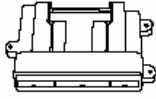

**Note:** If the package is sent without a claim number/claim number visible on the outside of the package, the shipment will be refused and returned at sender's expense.

5. Once a tracking number for the returning component has been issued to Code Systems, replacement components will be shipped within 24 hours via regular UPS ground transportation.
6. Dealer/FAD is responsible for service parts not returned/received by the Warranty Service Center within 30 days of the original claim date. Post the 60 days; the Dealer/FAD will be liable for all non-returned components at service part pricing.

Removal and reinstallation labor may be reimbursable under the New Vehicle Limited Warranty or 12-month/12,000 mile warranty (which ever is greater) and must be submitted by filling a warranty claim through ACES II.





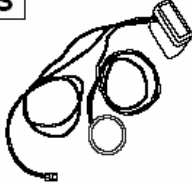
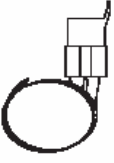







# REFERENCE SECTION

## KIT CONTENTS

<p><b>A</b></p>  <p>PC-14 - 7L2J-19G367-AA PC-34 - 7L3J-19G367-AA</p>	<p><b>B</b></p>  <p>RKEVSSRMST - 7L3J-19A498-AA RMST - 7L2J-19A498-AA VSS - 7L3J-19A498-BA</p>	<p><b>C</b></p>  <p>7L2J-15K601-AA</p>	<p><b>E</b></p>  <p>TYPE "A" 7L2J-14B504-AA</p>
<p><b>F</b></p>  <p>TYPE "B" 7L5J-14B504-AA</p>	<p><b>G</b></p>  <p>TYPE "C" 7W3J-14B504-AA</p>	<p><b>M</b></p>  <p>2W7J-19G366-AA</p>	<p><b>N</b></p>  <p>2W7J15603-AA</p>
<p><b>P</b></p> 	<p><b>Q</b></p> 	<p><b>R</b></p> 	<p><b>S</b></p>  <p>7L2Z-19G365-AA</p>
<p><b>T</b></p>  <p>YL3Z-19G390-AA</p>			

## PARTS BAG CONTENTS

NOTE: Part bag contents are not available as service items

<p><b>T</b></p> <p>750 OHM</p>  <p>1X</p>	<p><b>U</b></p> <p>1800 OHM</p>  <p>1X</p>	<p><b>V</b></p>  <p>2X</p>	<p><b>W</b></p>  <p>6X</p>
<p><b>X</b></p>  <p>2X</p>	<p><b>Y</b></p>  <p>5X</p>	<p><b>Z</b></p>  <p>10X</p>	<p><b>AA</b></p>  <p>1X</p>
<p><b>BB</b></p>  <p>2X</p>	<p><b>CC</b></p>  <p>7X</p>	<p><b>DD</b> FUSE BAG CONTENTS</p> <p>5A</p>  <p>1X</p>	<p><b>EE</b></p> <p>15A</p>  <p>PC-14 - 4X PC-34 - 7X</p>

**Remote Start System Kit (RMST) - TYPE "A"**

<b>REF</b>	<b>DESCRIPTION</b>	<b>QTY</b>
A	PC-14 MODULE ASSEMBLY	1
B	RMST DNA ASSEMBLY	1
C	1 BUTTON POWERCODE TRANSMITTER	2
E	TYPE "A" CUSTOM WIRING HARNESS	1
N	DIPOLE ANTENNA	1
M	HOOD SAFETY SWITCH ASSEMBLY	1
T - CC	INSTALLATION PARTS BAG	1
DD, EE	FUSE PARTS BAG	1
R	OPERATORS INSTRUCTION	1
Q	OPERATORS QUICK REFERENCE WALLET CARD	1
P	UNDERHOOD WARNING LABEL	1
S	PIK-4 PATS INTERFACE KIT	1
T	RELAY (7L2J-19G364-CA KIT ONLY)	2

**Remote Start System Kit (RMST) - TYPE "B"**

<b>REF</b>	<b>DESCRIPTION</b>	<b>QTY</b>
A	PC-34 MODULE ASSEMBLY	1
B	RMST DNA ASSEMBLY	1
C	1 BUTTON POWERCODE TRANSMITTER	2
F	TYPE "B" CUSTOM WIRING HARNESS	1
N	DIPOLE ANTENNA	1
M	HOOD SAFETY SWITCH ASSEMBLY	1
T - CC	INSTALLATION PARTS BAG	1
DD, EE	FUSE PARTS BAG	1
R	OPERATORS INSTRUCTION	1
Q	OPERATORS QUICK REFERENCE WALLET CARD	1
P	UNDERHOOD WARNING LABEL	1
T	RELAY	2
S	PIK-4 PATS INTERFACE KIT	1

**Remote Start System Kit (RMST) - TYPE "C"**

<b>REF</b>	<b>DESCRIPTION</b>	<b>QTY</b>
A	PC-34 MODULE ASSEMBLY	1
B	RMST DNA ASSEMBLY	1
C	1 BUTTON POWERCODE TRANSMITTER	2
G	TYPE "C" CUSTOM WIRING HARNESS	1
N	DIPOLE ANTENNA	1
M	HOOD SAFETY SWITCH ASSEMBLY	1
T - CC	INSTALLATION PARTS BAG	1
DD, EE	FUSE PARTS BAG	1
R	OPERATORS INSTRUCTION	1
Q	OPERATORS QUICK REFERENCE WALLET CARD	1
P	UNDERHOOD WARNING LABEL	1
T	RELAY	2
S	PIK-4 PATS INTERFACE KIT	1

## GENERAL PROCEDURES

### Proper Splicing Techniques

**NOTE:** Follow this procedure when a wire can be spliced without cutting the wire in half.

1. Strip approximately two inches of insulation from the wire to be installed in the vehicle.

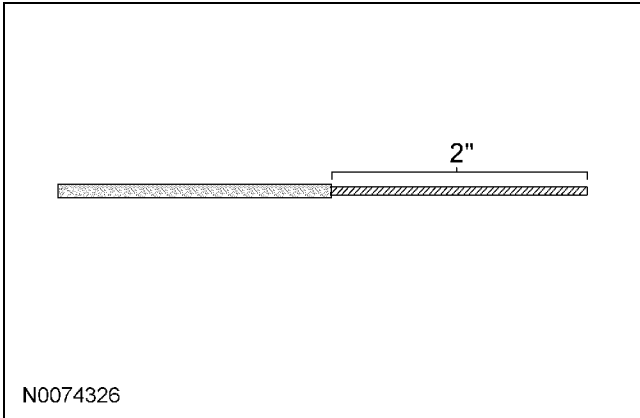

2. On the vehicle wire to be spliced into, strip one inch of insulation from the wire.

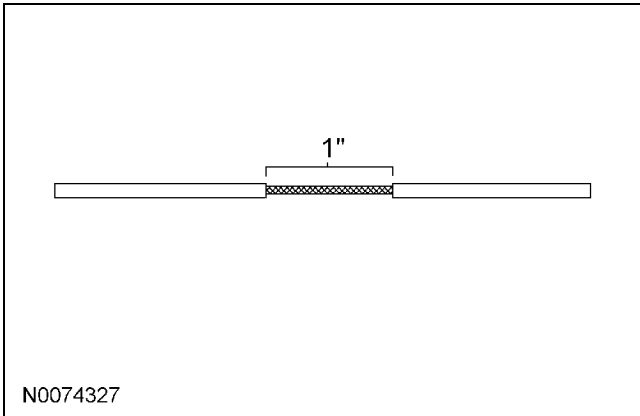

3. On the vehicle wire to be spliced into, separate the strands to allow the new wire to be placed between the parted strands of wire.

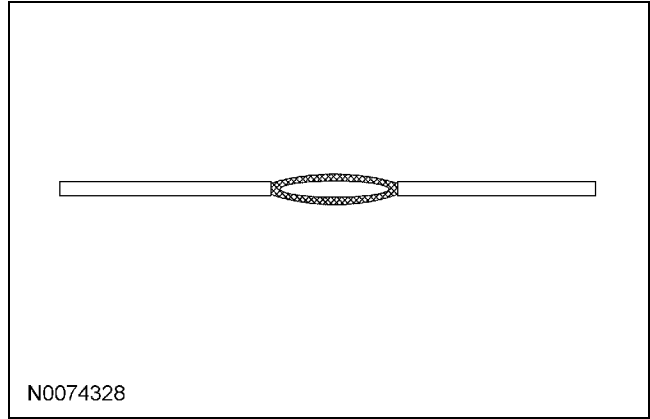

4. Insert the new wire between the parted strands. If more than one wire is being spliced, wrap them in opposite directions.

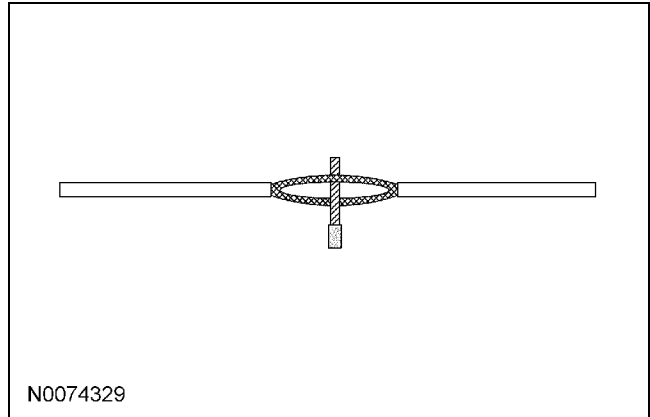

**NOTE:** Use Rosin Core Mildly-Activated (RMA) Solder. Do not use Acid Core Solder.

5. Wrap the new wire around one side of the split strands, then wrap it around the other side.
  - Solder the connection.

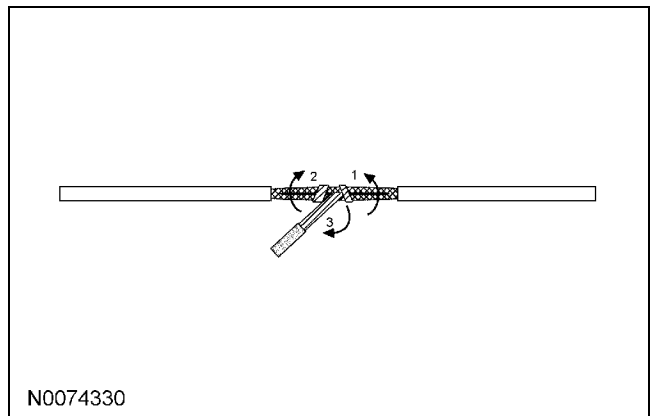

**GENERAL PROCEDURES (Continued)**

6. Wrap the connection with electrical tape so the tape covers the wires approximately two inches on either side of the connection.
  - Tape the wires together as shown in the illustration.

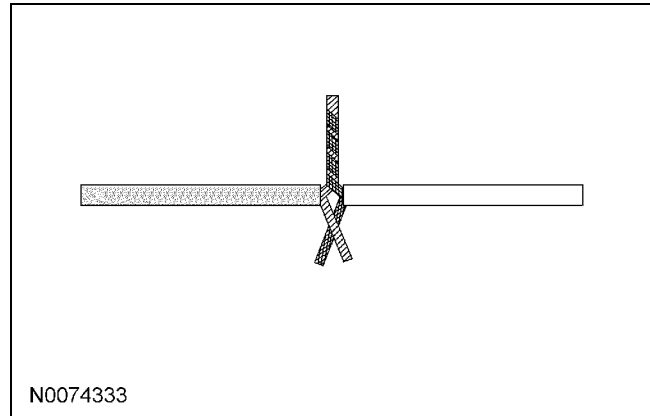
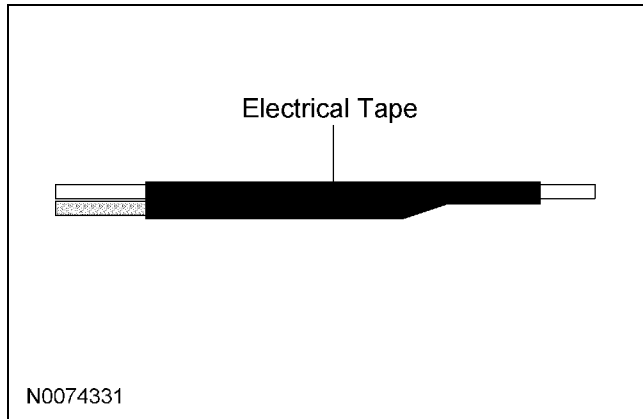

**NOTE:** Use Rosin Core Mildly-Activated (RMA) Solder. Do not use Acid Core Solder.

3. Lay the upper strand of wire to one side, then lay the lower strand of wire to the other side as shown in the illustration.
  - Solder the wires together.

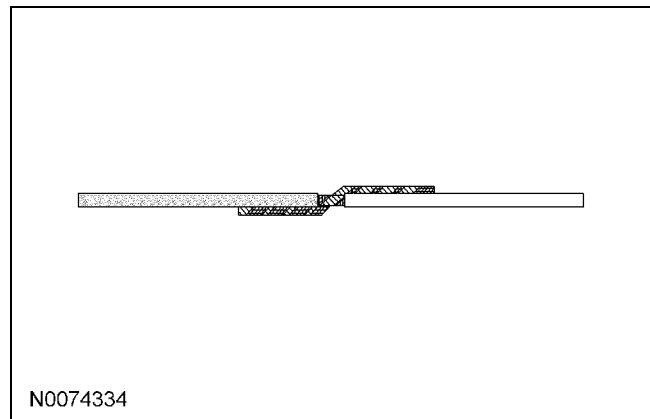

**Splicing End to End Connections**

**NOTE:** When both ends of the wire are cut, use the end to end wire splicing procedure.

**NOTE:** Follow the steps below for end to end wire splicing.

1. To make an end to end connection, start by stripping one inch of insulation from each of the wires. Part each wire into equal strands as shown in the illustration.

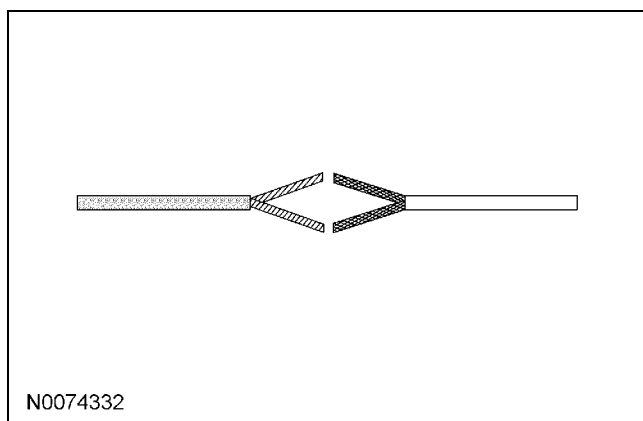

4. Wrap the connection with electrical tape so the tape covers the wires approximately two inches on either side of the connection.

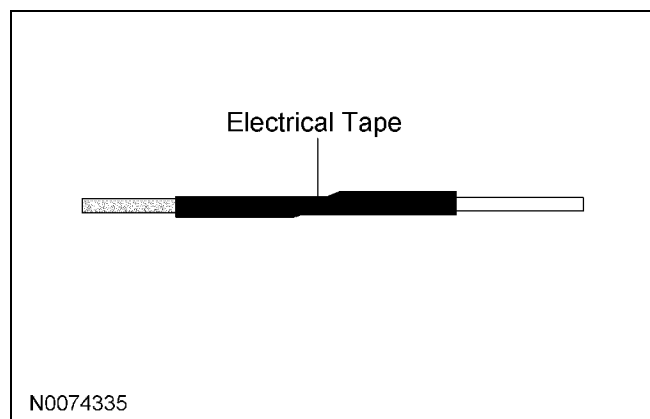

2. Place the wires next to each other and twist the upper and lower strands together as shown.

# REMOTE START SYSTEM INSTALLATION

## CONTENTS

### INSTALLATION

[Remote Start](#)

### GENERAL PROCEDURES

[Proper Splicing Techniques](#)

[Programming - Standard Remote Start](#)

[Functional Test - Standard Remote Start](#)

[Programming - Bidirectional Remote Start](#)

[Functional Test - Bidirectional Remote Start](#)

[Troubleshooting](#)

### WIRING DIAGRAMS

[Vehicle Specific Wiring Diagrams](#)

# INSTALLATION

## Remote Start

### Remote Start System RMST Components

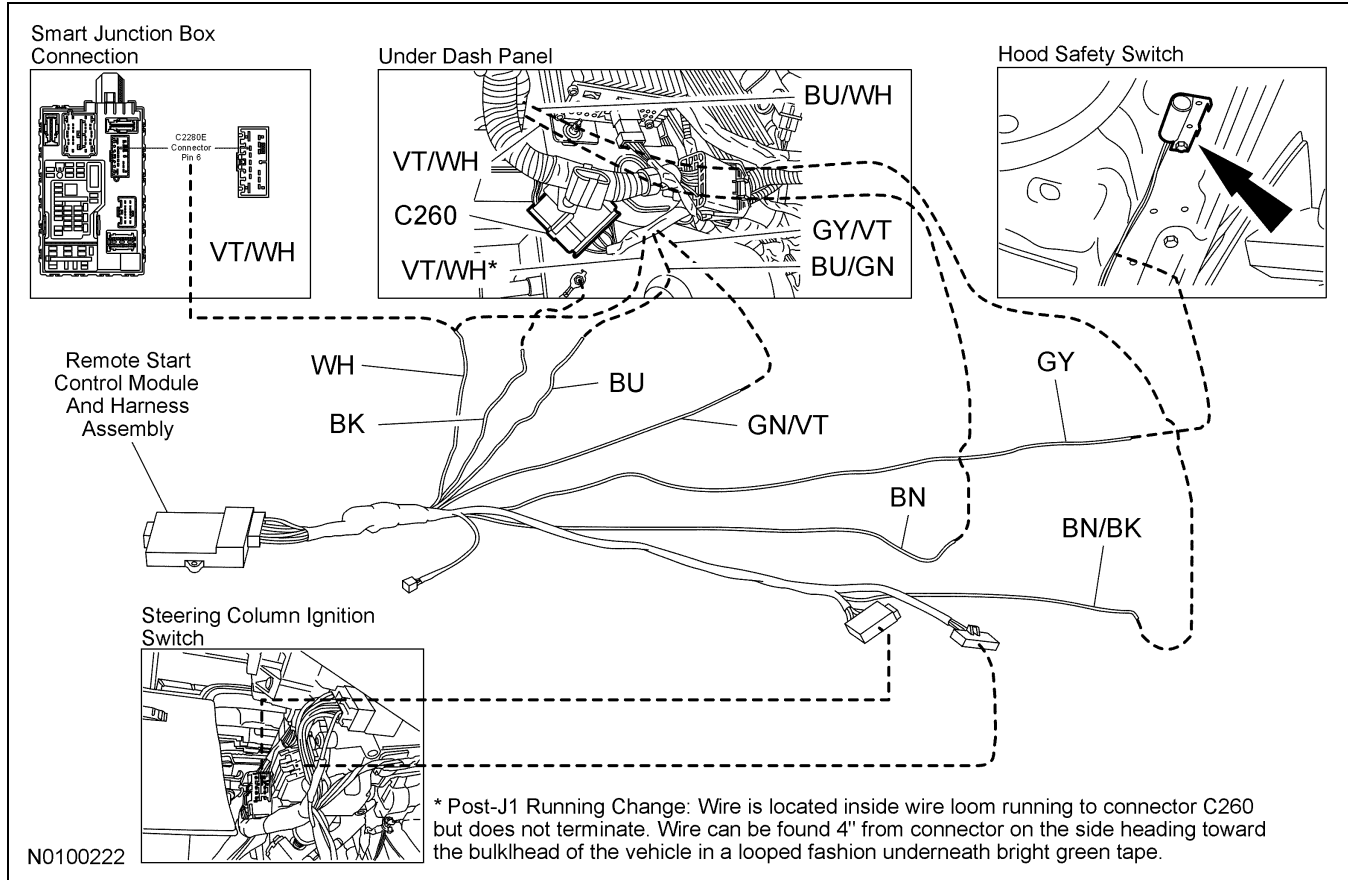

## Mustang

**NOTICE:** Remote start systems are only applicable to vehicles with automatic transmissions.

**NOTE:** Both original keys are required for all remote start systems on vehicles equipped with SECURILOCK.

1. Verify correct kit number.



**INSTALLATION (Continued)****Review Remote Start Installation Kit Contents**

**NOTE:** Use kit number 7L2J-19G364-AA (FIA), 8G1J-19G364-AA (FIA) or 7L2Z-19G364-AA (GFA) REMOTE START SYSTEM.

9G1Z-19G364-A (GFA) BIDIRECTIONAL REMOTE START SYSTEM.

**NOTE:** Kits are vehicle specific and are not interchangeable.

- Review the RMST kit contents.

**Remote Start System Standard Kit (RMST) Type - "A"**

QUANTITY	DESCRIPTION
1	TYPE - "A" MODULE ASSEMBLY
1	RMST SOFTWARE CARTRIDGE ASSEMBLY
2	1 BUTTON POWERCODE TRANSMITTER
1	TYPE - "A" CUSTOM WIRING HARNESS
1	ANTENNA
1	HOOD SAFETY SWITCH ASSEMBLY
1	INSTALLATION PARTS BAG
1	FUSE PARTS BAG
1	OPERATORS INSTRUCTIONS
1	OPERATORS QUICK REFERENCE WALLET CARD
1	UNDERHOOD WARNING LABEL
1	SECURILOCK INTERFACE KIT

- Review the RMST bidirectional kit contents.

**Remote Start System Bidirectional Kit (RMST) Type - "A"**

QUANTITY	DESCRIPTION
1	TYPE - "A" MODULE ASSEMBLY
1	RMST SOFTWARE CARTRIDGE ASSEMBLY
1	2 BUTTON POWERCODE TRANSMITTER
1	TYPE - "A" CUSTOM WIRING HARNESS
1	ANTENNA
1	ANTENNA HARNESS
1	HOOD SAFETY SWITCH ASSEMBLY
1	INSTALLATION PARTS BAG
1	FUSE PARTS BAG
1	OPERATORS INSTRUCTIONS
1	OPERATORS QUICK REFERENCE WALLET CARD
1	UNDERHOOD WARNING LABEL
1	SECURILOCK INTERFACE KIT

**Module Preparation**

- Place the supplied fuses into the power distribution block on the remote start control module.
  - Move the polarity jumpers to their proper locations on the control module, see illustration.

**INSTALLATION (Continued)**

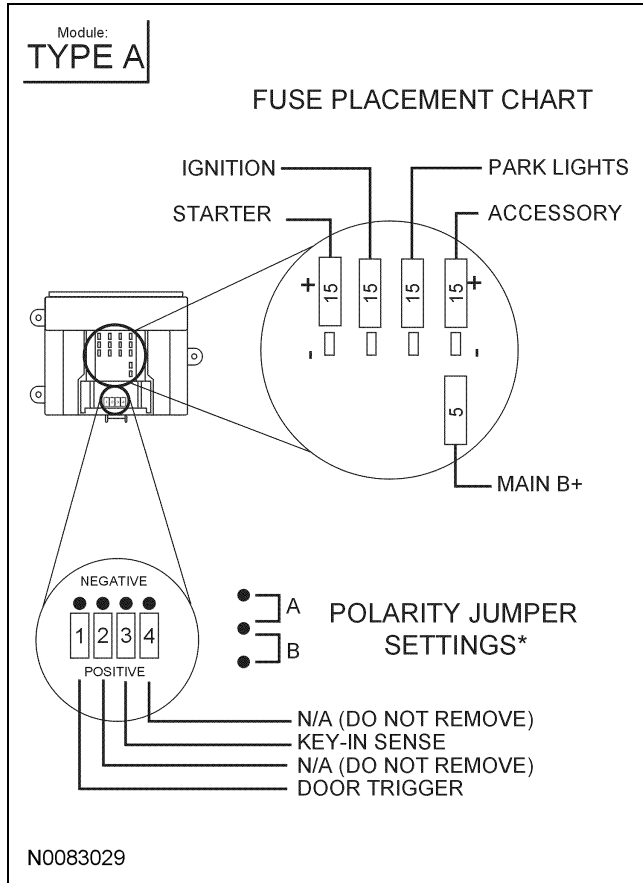

- Place the software cartridge onto the RMST control module.

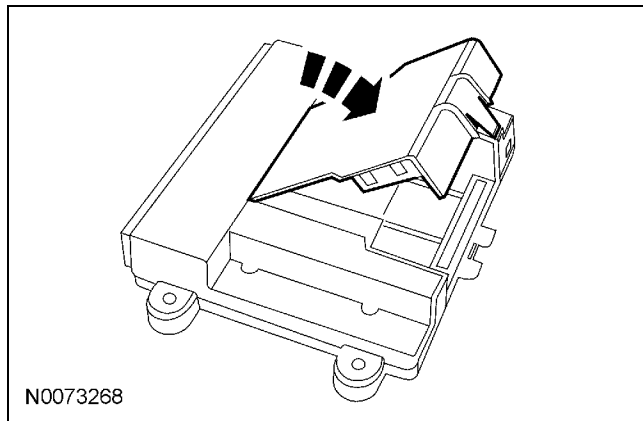

- Plug the wiring harness(es) into the module.
  - A - Harness: 24-way, used on all systems.
  - B - Harness: 10-way, used on all systems with RMST.

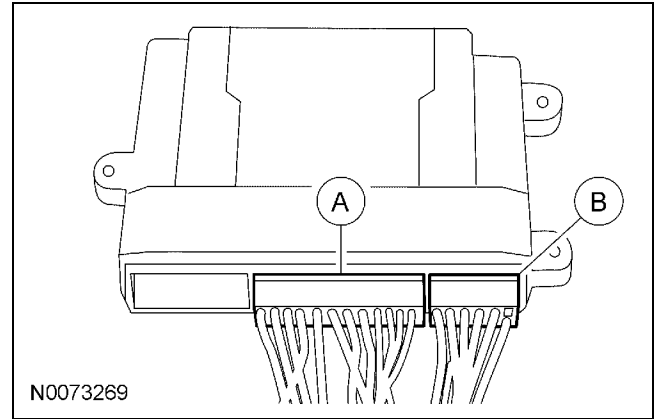

- NOTE:** Do not cut the override programming button off of the harness, it is used for all installations.

**NOTE:** For vehicle specific wiring diagram(s) click [here](#).

Referring to the vehicle specific wiring section for the system being installed, gather all individual wires that will be routed to the same areas of the vehicle into groups. Cover each wire group with electrical tape for approximately 18". Depending on the vehicle, there will be 2 to 5 different wire groups.

Trim the unused wires approximately 6 - 8" from the module.

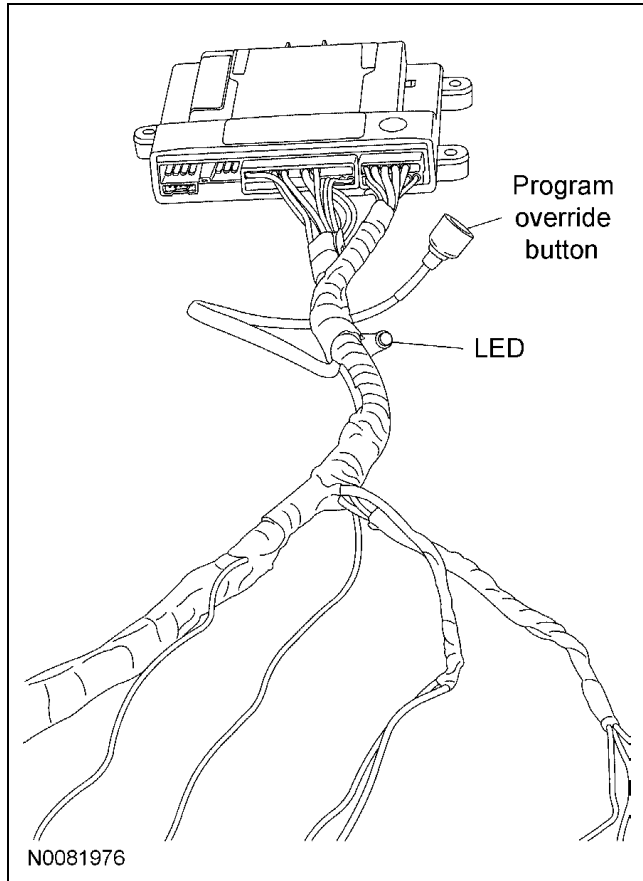
**INSTALLATION (Continued)**

8. Tape the harness sections together, making sure to cover all of the unused wires.

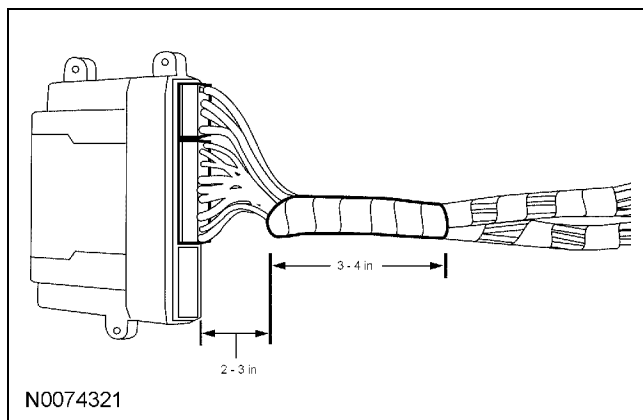
**Vehicle Preparation**

9. Remove the left hand scuff plate and cowl trim panel.

10. Remove the 2 lower instrument panel steering column cover screws and the cover.
11. Remove the 4 bolts and the steering column opening trim panel reinforcement.
12. **NOTE:** Release the upper steering column shroud by carefully pressing the sides inward. Remove the 3 lower steering column shroud screws, then separate the upper and lower shrouds.
13. Remove the right hand scuff plate, cowl trim panel and fuse door panel.

**Antenna Mounting**

**NOTE:** For good range of operation, the antenna must be installed correctly.

**NOTE:** Keep these points in mind when selecting a location and mounting the antenna.

- Do not mount the antenna behind or on any metal film or window tinting on the windshield.
- Do not mount the antenna so that one of the antenna elements touches or crosses any vehicle wiring and/or metal.
- On vehicles without metal film in the windshield around the rear view mirror, mount the antenna between the headliner and the rear view mirror.
- On vehicles equipped with an electronic mirror, or on vehicles with metal film around the rearview mirror, mount the antenna approximately 3 inches below the mirror attachment point to the windshield and/or mirror electronics.

14. Choose a suitable mounting location following the guidelines above.

**Install The Antenna**

15. Clean the mounting surface using an alcohol base solution and a clean cloth.

**INSTALLATION (Continued)**

16. **NOTE:** Do not touch the adhesive, reduced adhesion may result.

**NOTE:** Make sure that the long wire on the antenna is pointing towards the top of the windshield since this wire will be routed along the headliner.

**NOTE:** The wire will be attached to the control module later in this procedure.

Remove the protective backing from the adhesive on the antenna and firmly press the body of the antenna to the windshield.

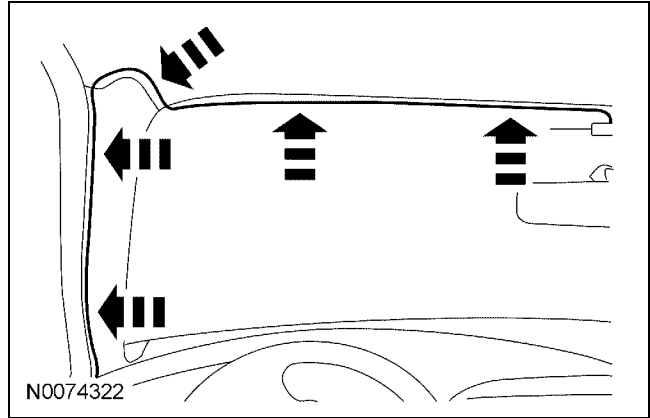

19. Reposition the A pillar trim panel.

**Install The Securilock Interface Kit**

20. Route the ring of the SECURILOCK interface antenna lead up along the steering column to the PATS transceiver location.

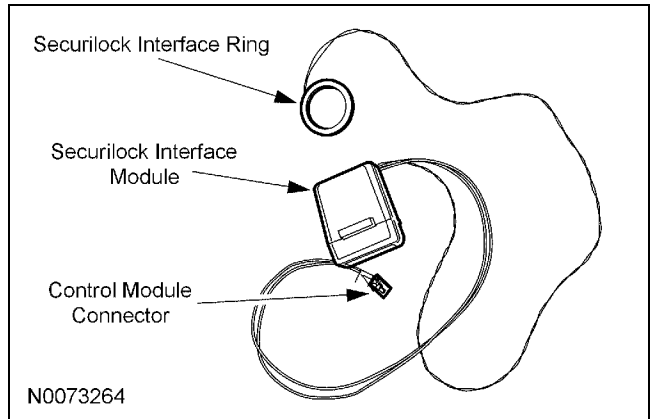
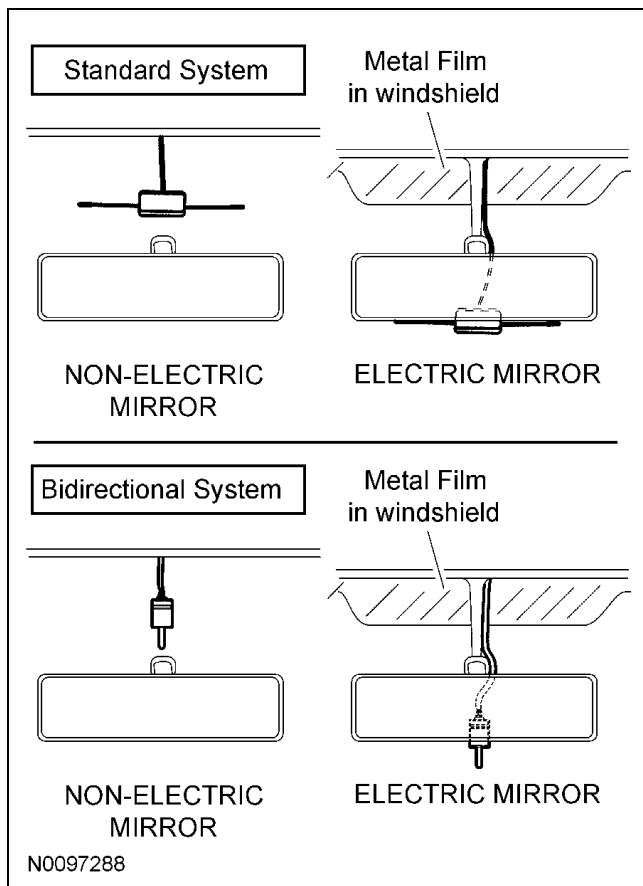

21. Following the directions on the supplied tube of adhesive primer, apply a thin coating around the transceiver antenna coil and allow to dry for approximately 5 minutes.

17. If necessary, position the A pillar trim slightly outward to provide access to route the antenna wire.

**NOTE:** Do not route the antenna wire over the top of the air bag.

18. Route the antenna cable along the headliner and down the A pillar towards the floor.

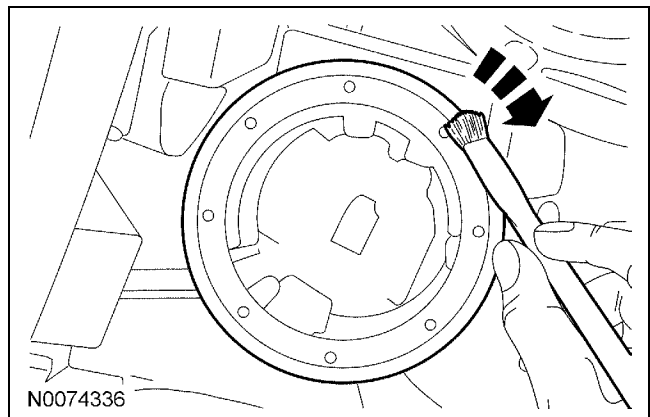

## INSTALLATION (Continued)

22. **NOTICE:** Do not damage the transceiver ring during installation or while installing the steering column shroud.

A damaged transceiver ring will result in an inoperable remote start system.

Remove the protective backing from the SECURILOCK antenna ring. Place the SECURILOCK ring over the PATS transceiver and press firmly in place.

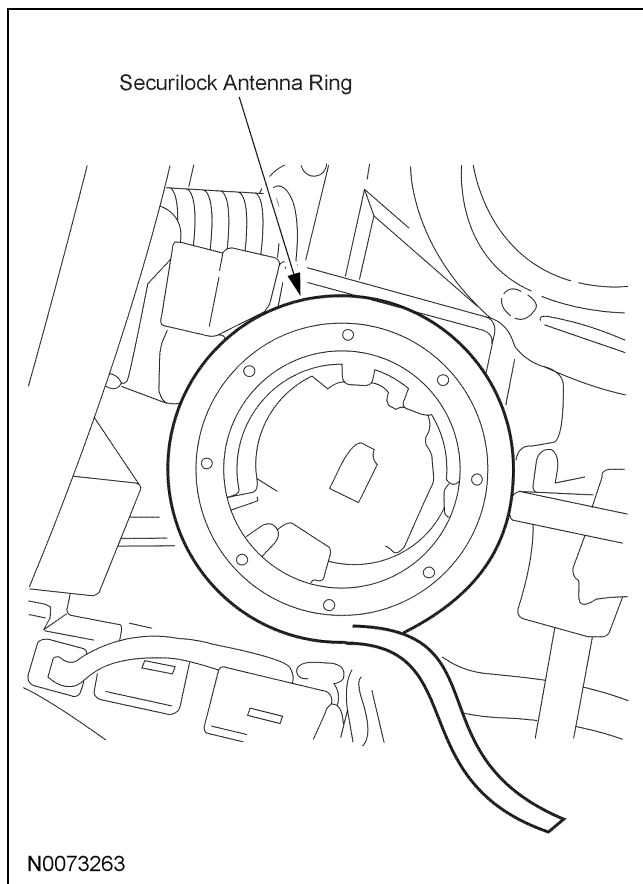

### Install The Securilock Interface Module

23. **NOTE:** Do Not mount the SECURILOCK Interface Module to or within 3" of a metal surface, including any underdash brackets, or in the knee bolster area.

Mount the SECURILOCK Interface Module to an underdash wiring harness using one of the supplied long tie wraps.

24. **NOTICE:** Do not attach the harness to the steering column.

Route the harness and connector the to module mounting location.

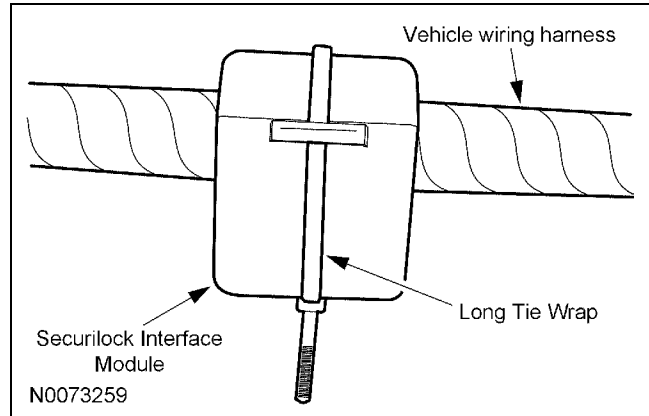

### Install the Remote Start Control Module and Harness Assembly

25. Place the remote start module and harness assembly on the floor of the vehicle.

### Identify Circuit Wires For Connections

**NOTE:** For vehicle specific wiring diagram(s) click [here](#).

**NOTE:** For proper wire splicing techniques click [here](#).

26. Connect the Black ground wire from the remote start module harness to the chassis ground point at the driver kick panel.

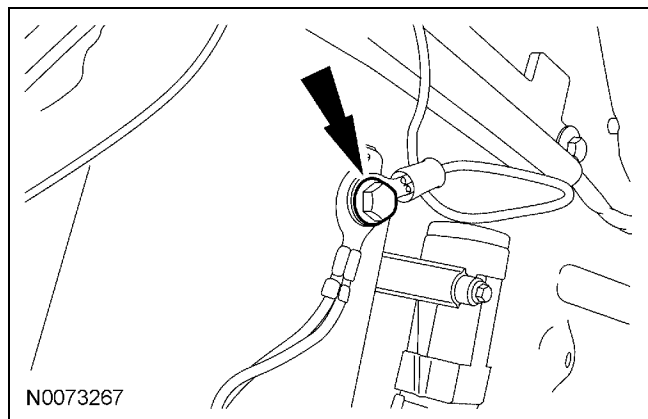

27. Disconnect the ignition switch electrical connector.
28. Connect the remote start harness hard shell connectors to the ignition switch and ignition switch connector

**INSTALLATION (Continued)**

29. **NOTE:** A DVOM connected to the correct wire will show 12V, then show 0V when the horn button is held.
- A logic probe will show power on the correct wire, then show ground when the horn button is held.
- NOTE:** Wire is located inside wire convolute running to connector C260 but does not terminate. Wire can be found within 2-6'' from connector on the side heading into main IP harness in a looped fashion underneath bright green tape.
- Identify the Blue/White horn circuit wire under dash panel.
30. Connect the Brown/Black wire from the remote start module harness to the Blue/White horn circuit wire under dash panel.
31. **NOTE:** A DVOM connected to the correct wire will show 12V, then show 0V when the door lock switch is pressed.
- A logic probe will show power on the correct wire, then show ground when the door lock switch is pressed.
- NOTE:** Wire is located inside wire loom running to connector C260 but does not terminate. Wire can be found 4'' from connector on the side heading toward the bulkhead of the vehicle in a looped fashion underneath bright green tape.
- Identify the Blue/Green power door lock circuit wire under dash panel.
32. Connect the Blue wire from the remote start module harness to the Blue/Green wire under dash panel.
33. **NOTE:** A DVOM connected to the correct wire will show 12V with the vehicle door(s) open and the dome light on, then show 0V with the vehicle door(s) closed and the dome light off.
- NOTE:** A logic probe connected to the correct wire will show power with the vehicle door(s) open and the dome light on, then show ground with the vehicle door(s) closed and the dome light off.
- NOTE:** Wire is located inside wire loom running to connector C260 but does not terminate. Wire can be found 4'' from connector on the side heading toward the bulkhead of the vehicle in a looped fashion underneath bright green tape.
- NOTE:** Be sure that the dome light has timed out and is off before performing the door closed test.
- Be sure that the dome lamp is illuminated before performing the door open test.
- Identify the Grey/Violet dome light circuit wire under dash panel.
34. Connect the Green/Violet wire from the remote start module harness to the Grey/Violet dome light circuit wire under dash panel.
35. **NOTE:** A DVOM connected to the correct wire will show 0V, then show 12V while depressing the brake pedal.
- A logic probe will show ground when on the correct wire, then show power while depressing the brake pedal.
- NOTE:** Wire is located inside wire convolute running to connector C260 but does not terminate. Wire can be found within 2-6'' from connector on the side heading into the main IP harness in a looped fashion underneath bright green tape.
- Identify the Violet/White brake switch circuit wire under dash panel.
36. Connect the Brown wire from the remote start module harness to the Violet/White brake switch circuit wire under dash panel.

**INSTALLATION (Continued)**

37. **NOTE:** A DVOM connected to the correct wire will show 12V, when the headlight switch is ON, then show 0V when the headlight switch is OFF.

A logic probe will show power on the correct wire when the headlight switch is ON, then show ground when the headlight switch is OFF.

**NOTE:** Do NOT splice into any circuits leading to the back of the headlight switch. Doing so may lead to headlight switch failure.

**NOTE:** Post J1 Running Change: Wire is located inside wire loom running to connector C260 but does not terminate. Wire can be found 4' from connector on the side heading toward the bulkhead of the vehicle in a looped fashion underneath bright green tape.

Identify the Violet/White parking light circuit wire at the Smart Junction Box (SJB) connector C2280E Pin 6.

38. Connect the White wire from the remote start module harness to the Violet/White parking light circuit wire at the SJB connector C2280E Pin 6.

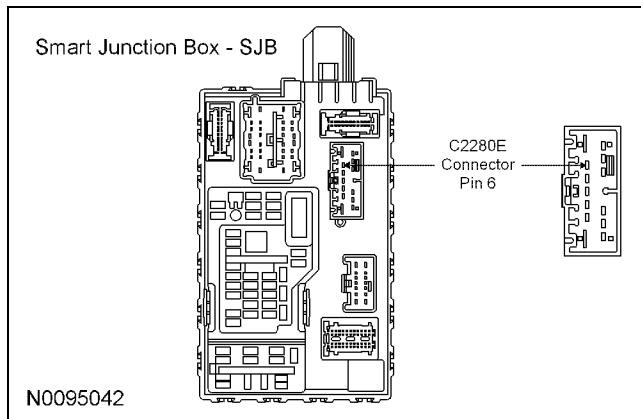
**Install The Hood Safety Switch**

39. **NOTE:** Route the hood safety switch wire carefully avoiding any moving parts or components that can produce excessive heat.

**NOTE:** Using a piece of convolute adds in the appearance of the installation.

**NOTE:** The switch should be positioned about 30 degrees below parallel to the ground to accommodate for parking on inclines.

Failure to position the switch properly could result in one of the following:

- False alarm trips
- Non-Remote Start events
- Inadvertent shutdown during Remote Start

Locate an easy to access area near the driver side hood hinge and install the hood safety switch using the supplied metal screws.

40. Apply rustproofing compound (PM-13-A) to the drilled hole and torque the screw to 1.00 Nm (10 lb-in).

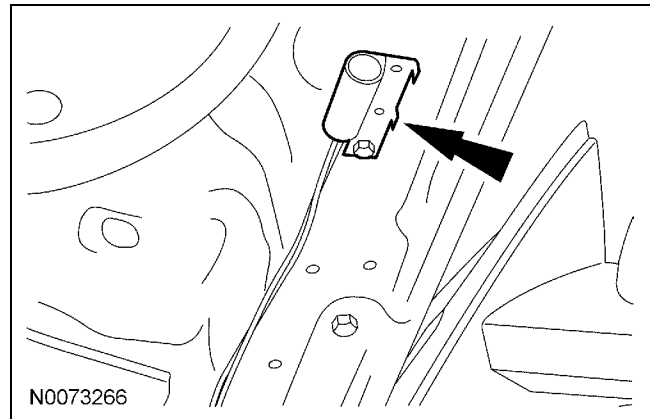

**INSTALLATION (Continued)**

41. Connect hood switch ground wire to a suitable location on the bulkhead.

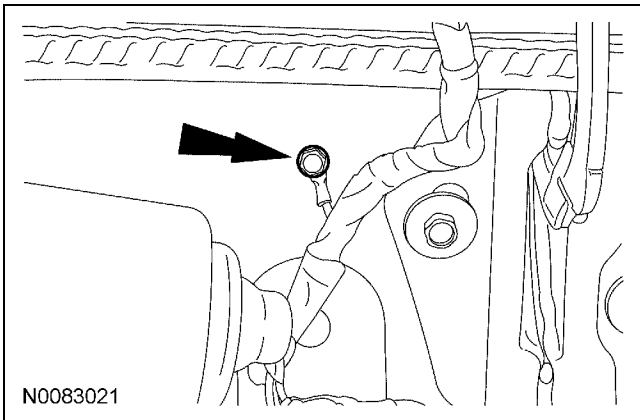

42. **NOTE:** Place the label on the radiator fan shroud or similar area.

Install the underhood warning label

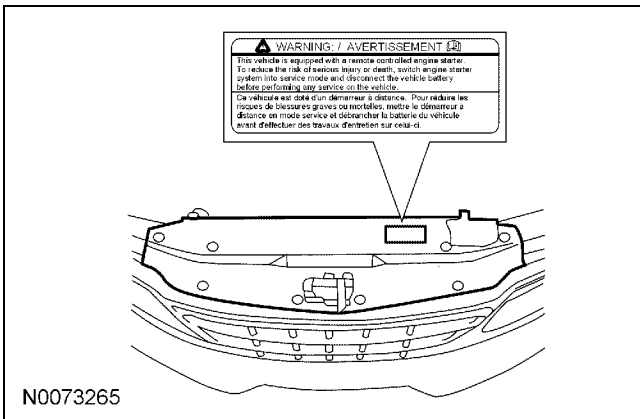

43. Route the Gray hood safety switch wire through the bulkhead into the engine compartment and attach to the hood safety switch.
44. Connect the antenna to the RMST control module.

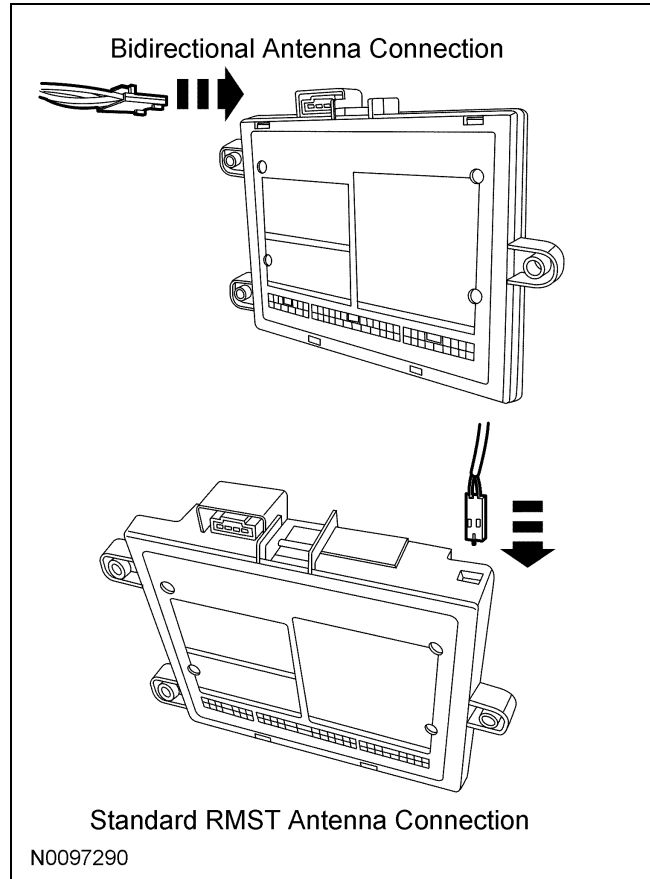

45. Connect the SECURILOCK interface module to the RMST control module.

**Program The RMST System**

46. Refer to the RMST programming section for this vehicle [click here](#).

**Secure RMST Harness and Control Module**

47. Use the supplied tie wraps to secure the RMST harness wires.
48. **NOTE:** Do not mount the control module in the knee bolster area.
- Secure the control module at three points to the vehicle.
- Use the supplied long tie wraps to mount the RMST control module to the underdash wiring harness.

**Install Trim**

49. Install the right hand scuff plate, cowl trim panel and fuse door panel.



---

**INSTALLATION (Continued)**

- |   |  |
|---|--|
| 50. Assemble the upper and lower steering column shrouds, and install the 3 lower shroud screws.  | 52. Install the lower instrument panel steering column cover and screws. |
| 51. Install the steering column opening trim panel reinforcement.<br>Install the 4 bolts. <ul style="list-style-type: none"><li>• Tighten to 9 Nm (80 lb-in).</li></ul> | 53. Install the left hand scuff plate and cowl trim panel.               |
-

## GENERAL PROCEDURES

### Programming - Standard Remote Start

#### Programming the Module

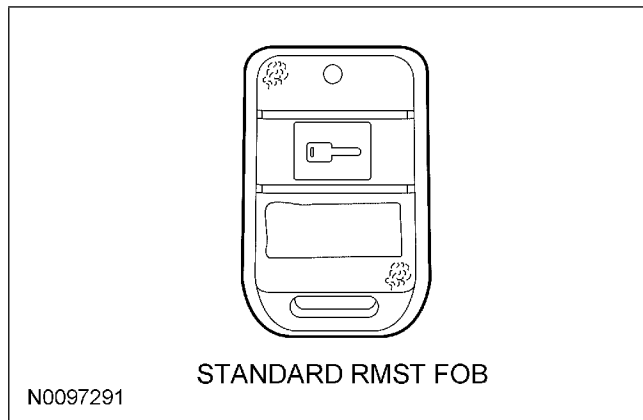

- NOTE:** If the remote start options (Key-in sense polarity, door ajar polarity, or tach mode) are not programmed correctly, vehicle will not remote start or operate properly.

**NOTE:** Make sure that the hood and doors are closed before proceeding.

**NOTE:** The LED on the remote start harness must be visible to complete module programming.

**NOTE:** The remote start override button must be accessible.

#### Programming Options: Entering Programming Mode

- See chart below for programming information.

##### Program Bank 2 Chart (5 Honks)

BANK	OPTIONS	DESCR	LED
2	1	TACHLESS MODE	ON

- Press and hold the brake pedal.
- Turn the ignition key to the RUN position.  
The dome light will turn off.

- Press and hold the remote start system override button for at least 10 seconds.

After 10 seconds the horn will honk 3 times, indicating the system is now in the learn mode.

Release the brake pedal and the RMST override button.

- Press and release the override button. The horn will honk 4 times indicating the system has entered the first program bank.

If not, please check the following:

- Brake pedal switch wire solder connection.
- Hood closed and Grey hood safety switch wire solder connection.
- All doors closed and dome light circuit wire solder connections.
- The key is in the RUN position.
- The software cartridge is firmly seated in the RMST module.
- The RMST harness connections are firmly seated in the RMST module.

**NOTE:** If you require additional assistance: CALL 1-800-FORD KEY.

- Press and release the override button again. The horn will honk 5 times indicating the system has entered the second program bank.
- Press and release the brake pedal.  
The horn will honk 1 time indicating the system has entered the option 1 of the second program bank.

**NOTICE:** When turning LED on or off using remote start fob button quickly press and immediately release the remote start button.

**Failure to quickly release the remote start fob button will result in system defaulting to the factory options.**

- The LED must be on for option 1. If the LED is illuminated no action is required. If the LED is not illuminated press the remote start fob button and verify the LED illuminates.

**GENERAL PROCEDURES (Continued)**

**NOTE:** If the remote start fob button is held for more than 3 seconds the system will chirp the horn 4 times, indicating the system has returned to factory default settings. If this occurs return to step 1 of the programming section and reprogram the remote start module.

**NOTE:** The remote start module is now programmed.

10. Remove the ignition key.

**Programming the SECURILOCK**

**NOTE:** Two PATS keys are required to program the SECURILOCK.

**NOTE: IMPORTANT:** Each of the following steps should be completed with no more than 5 seconds delay between steps.

11. Insert the first ignition key and turn to the run position.

Watch for the PATS light to turn off. Remove the first key.

12. Insert the second ignition key and turn to the run position.

Watch for the PATS light to turn off. Remove the second key.

13. Press and hold the remote start button



for 3 seconds.  
The PATS light should stay on for 3-5 seconds before turning off, which means that the SECURILOCK was successfully programmed.

**NOTE:** If the PATS light blinks rapidly, repeat steps 1-3 to retry programming the SECURILOCK.

**NOTE:** The engine will start if the Remote Start kit has been installed correctly, the brake is not depressed, and the hood and doors are closed.

## GENERAL PROCEDURES

### Functional Test - Standard Remote Start

**NOTE:** If during any of the steps of the functional test, the remote start system or vehicle doesn't react or perform accordingly, please refer to the remote start troubleshooting guide.

**NOTE:** For remote start troubleshooting guide click [here](#).

1. Make sure all doors are closed but hood is open and windows are down (doors will be locking).
2. Press and hold the Start button on the remote control key fob for 2-3 seconds - Horn should honk once indicating receipt of the start request.
3. The remote start systems should turn on the ignition, but then honk the horn twice and shut down indicating the hood is open.
4. Close the hood, and insert a key into the ignition switch.
5. Attempt to re-start the vehicle again using the key fob.
6. The remote start systems should turn on the ignition, but then honk the horn five times and shut down indicating a key is in the ignition switch.
7. Remove the key and open a door.
8. Attempt to re-start the vehicle again using the key fob.
9. The remote start systems should turn on the ignition, but then honk the horn three times and shut down indicating a door is open.
10. Close the door.
11. Attempt to re-start the vehicle again using the key fob.

12. Once the vehicle starts, verify that all heat and A/C functions operate normally and that the doors have locked.
13. On vehicles equipped with power window interrupt, Attempt to close windows to check power window interrupt function.
14. Once all systems have been checked, open the door\*, or press the brake pedal - the remote start systems should shut down.

**NOTE:** \*MyKey vehicle remote start systems will shut down upon vehicle entry. Please see vehicle owner's guide or remote start owner's manual for more information.

### Troubleshooting

15. **NOTE:** When attempting to remote start your vehicle, the system has several safety checks that it performs. If any of these inputs are present that should not be, the system will respond back to you with several horn "chirps" to help you identify which input is present. These "chirps" will occur after initiating a start sequence with the transmitter, the system will turn on the ignition, but then respond back with several horn "chirps" and abort the starting process.

**Example:** Depress the remote start fob button for 3 seconds and then release. The vehicle horn will "chirp" one time to indicate that RMST signal was received. If the vehicle doesn't start and the horn "chirps" 3 times, there is a fault - "Vehicle Door is Open"

CHIRPS	PROBLEM
1 Chirp	SECURILOCK not programmed correctly, or the SECURILOCK antenna ring is damaged.
2 Chirps	BRAKE is being pressed, or the HOOD is open.
3 Chirps	One of the vehicles DOORS are open.
4 Chirps	TACH not programmed.

**GENERAL PROCEDURES (Continued)**

---

<b>CHIRPS</b>	<b>PROBLEM</b>
5 Chirps	The KEY is in the ignition.
6 Chirps	The remote start system is in SERVICE/VALET mode.

---

## GENERAL PROCEDURES

### Programming - Bidirectional Remote Start

#### Programming the Module

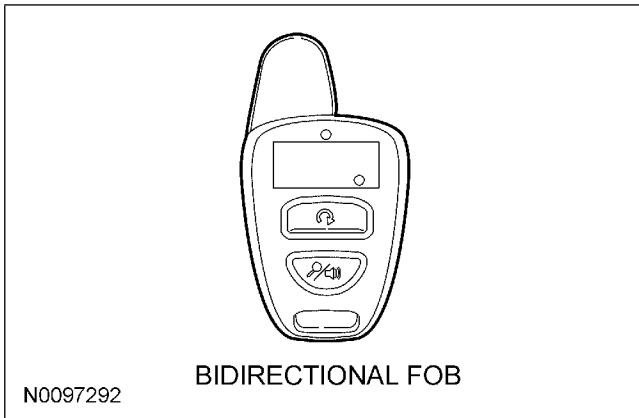

- NOTE:** If the remote start options (Key-in sense polarity, door ajar polarity, or tach mode) are not programmed correctly, vehicle will not remote start or operate properly.

**NOTE:** Make sure that the hood and doors are closed before proceeding.

**NOTE:** The LED on the remote start harness must be visible to complete module programming.

**NOTE:** The remote start override button must be accessible.

#### Programming Options: Entering Programming Mode

- See chart below for programming information.

#### Program Bank 2 Chart (5 Honks)

BANK	OPTIONS	DESCR	LED
2	1	TACHLESS MODE	ON

- Press and hold the brake pedal.
- Turn the ignition key to the RUN position.  
The dome light will turn off.

- Press and hold the remote start system override button for at least 10 seconds.

After 10 seconds the horn will honk 3 times, indicating the system is now in the learn mode.

Release the brake pedal and the RMST override button.

- Press and release the override button. The horn will honk 4 times indicating the system has entered the first program bank.

If not, please check the following:

- Brake pedal switch wire solder connection.
- Hood closed and Grey hood safety switch wire solder connection.
- All doors closed and dome light circuit wire solder connections.
- The key is in the RUN position.
- The software cartridge is firmly seated in the RMST module.
- The RMST harness connections are firmly seated in the RMST module.

**NOTE:** If you require additional assistance: CALL 1-800-FORD KEY.

- Press and release the override button again. The horn will honk 5 times indicating the system has entered the second program bank.
- Press and release the brake pedal.  
The horn will honk 1 time indicating the system has entered the option 1 of the second program bank.

**NOTICE:** When turning LED on or off using remote start fob button quickly press and immediately release the remote start button.

**Failure to quickly release the remote start fob button will result in system defaulting to the factory options.**

- The LED must be on for option 1. If the LED is illuminated no action is required. If the LED is not illuminated press the remote start fob button and verify the LED illuminates.

**GENERAL PROCEDURES (Continued)**

**NOTE:** If the remote start fob button is held for more than 3 seconds the system will chirp the horn 4 times, indicating the system has returned to factory default settings. If this occurs return to step 1 of the programming section and reprogram the remote start module.

**NOTE:** The remote start module is now programmed.

10. Remove the ignition key.

**Programming the SECURILOCK**

**NOTE:** Two PATS keys are required to program the SECURILOCK.

**NOTE: IMPORTANT:** Each of the following steps should be completed with no more than 5 seconds delay between steps.

11. Insert the first ignition key and turn to the run position.

Watch for the PATS light to turn off. Remove the first key.

12. Insert the second ignition key and turn to the run position.

Watch for the PATS light to turn off. Remove the second key.

13. Press the remote start button  twice within 3 seconds.

The PATS light should stay on for 3-5 seconds before turning off, which means that the SECURILOCK was successfully programmed.

**NOTE:** If the PATS light blinks rapidly, repeat steps 1-3 to retry programming the SECURILOCK.

**NOTE:** The engine will start if the Remote Start kit has been installed correctly, the brake is not depressed, and the hood and doors are closed.

## GENERAL PROCEDURES

### Functional Test - Bidirectional Remote Start

**NOTE:** If during any of the steps of the functional test, the remote start system or vehicle doesn't react or perform accordingly, please refer to the remote start troubleshooting guide.

**NOTE:** For remote start troubleshooting guide click [here](#).

1. Make sure all doors are closed but hood is open and windows are down (doors will be locking).
2. Press the Start button on the remote control key fob twice within 3 seconds - Horn should honk once indicating receipt of the start request.
3. The remote start systems should turn on the ignition, but then honk the horn twice and shut down indicating the hood is open.
4. Close the hood, and insert a key into the ignition switch.
5. Attempt to re-start the vehicle again using the key fob.
6. The remote start systems should turn on the ignition, but then honk the horn five times and shut down indicating a key is in the ignition switch.
7. Remove the key and open a door.
8. Attempt to re-start the vehicle again using the key fob.
9. The remote start systems should turn on the ignition, but then honk the horn three times and shut down indicating a door is open.
10. Close the door.
11. Attempt to re-start the vehicle again using the key fob.

12. Once the vehicle starts, verify that all heat and A/C functions operate normally and that the doors have locked.
13. On vehicles equipped with power window interrupt, Attempt to close windows to check power window interrupt function.
14. Once all systems have been checked, open the door\*, or press the brake pedal - the remote start systems should shut down.

**NOTE:** \*MyKey vehicle remote start systems will shut down upon vehicle entry. Please see vehicle owner's guide or remote start owner's manual for more information.

### Troubleshooting

15. **NOTE:** When attempting to remote start your vehicle, the system has several safety checks that it performs. If any of these inputs are present that should not be, the system will respond back to you with several horn "chirps" to help you identify which input is present. These "chirps" will occur after initiating a start sequence with the transmitter, the system will turn on the ignition, but then respond back with several horn "chirps" and abort the starting process.

**Example:** Depress the remote start fob button for 3 seconds and then release. The vehicle horn will "chirp" one time to indicate that RMST signal was received. If the vehicle doesn't start and the horn "chirps" 3 times, there is a fault - "Vehicle Door is Open"

CHIRPS	PROBLEM
1 Chirp	SECURILOCK not programmed correctly, or the SECURILOCK antenna ring is damaged.
2 Chirps	BRAKE is being pressed, or the HOOD is open.
3 Chirps	One of the vehicles DOORS are open.
4 Chirps	TACH not programmed.



TYPE "A" CUSTOM WIRE HARNESS

RMST MODULE WIRE HARNESS

STEERING COLUMN HARNESS

	Color	Function
A-3	PINK	Ignition Input/Output
A-2	ORANGE	HVAC Output
A-13	VIOLET	Starter Output
B-8	BLACK/WHITE	Key-in-sense Input
A-4	RED	Battery

	Color	Function
A-21	BROWN/BLACK	Horn Relay Output

DRIVER'S KICK PANEL HARNESS

	Color	Function
A-5	BLACK	Ground
A-24	BLUE	Door Lock Output
A-2	GREEN/VIOLET	Door Ajar Switch Input
B-7	BROWN	Brake Input

HEADLAMP SWITCH HARNESS

	Color	Function
A-1	WHITE	Parking Light Output

UNDER HOOD HARNESS

	Color	Function
A-19	GRAY	Hood Open Switch Input

VEHICLE HARNESS

IGNITION SWITCH

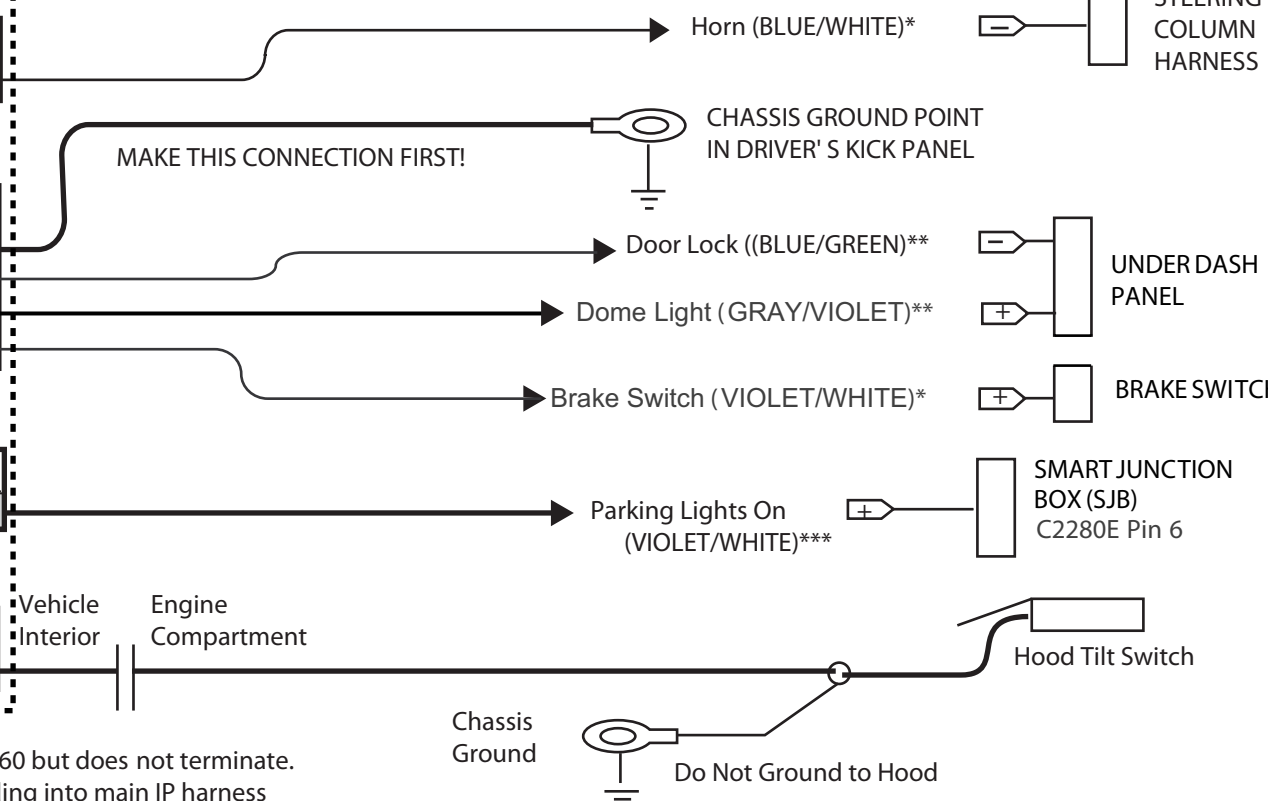

\*Wire is located inside wire convolute running to connector C260 but does not terminate. Wire can be found within 2-6" from connector on the side heading into main IP harness in a looped fashion underneath bright green tape.

\*\*Wire is located inside wire loom running to connector C260 but does not terminate. Wire can be found 4" from connector on the side heading toward the bulkhead of the vehicle in a looped fashion underneath bright green tape.

\*\*\* Post-J1 Running Change: Wire is located inside wire loom running to connector C260 but does not terminate. Wire can be found 4" from connector on the side heading toward the bulkhead of the vehicle in a looped fashion underneath bright green tape.

[Manual Table of Contents](#)

# REMOTE START SYSTEM INSTALLATION - NON PEPS EQUIPPED VEHICLES

## CONTENTS

### INSTALLATION

[Remote Start](#)

### GENERAL PROCEDURES

[Proper Splicing Techniques](#)

[Programming - Standard Remote Start](#)

[Functional Test - Standard Remote Start](#)

[Programming - Bidirectional Remote Start](#)

[Functional Test - Bidirectional Remote Start](#)

[Troubleshooting](#)

### WIRING DIAGRAMS

[Vehicle Specific Wiring Diagrams](#)

# INSTALLATION

## Remote Start

### Remote Start System RMST Components

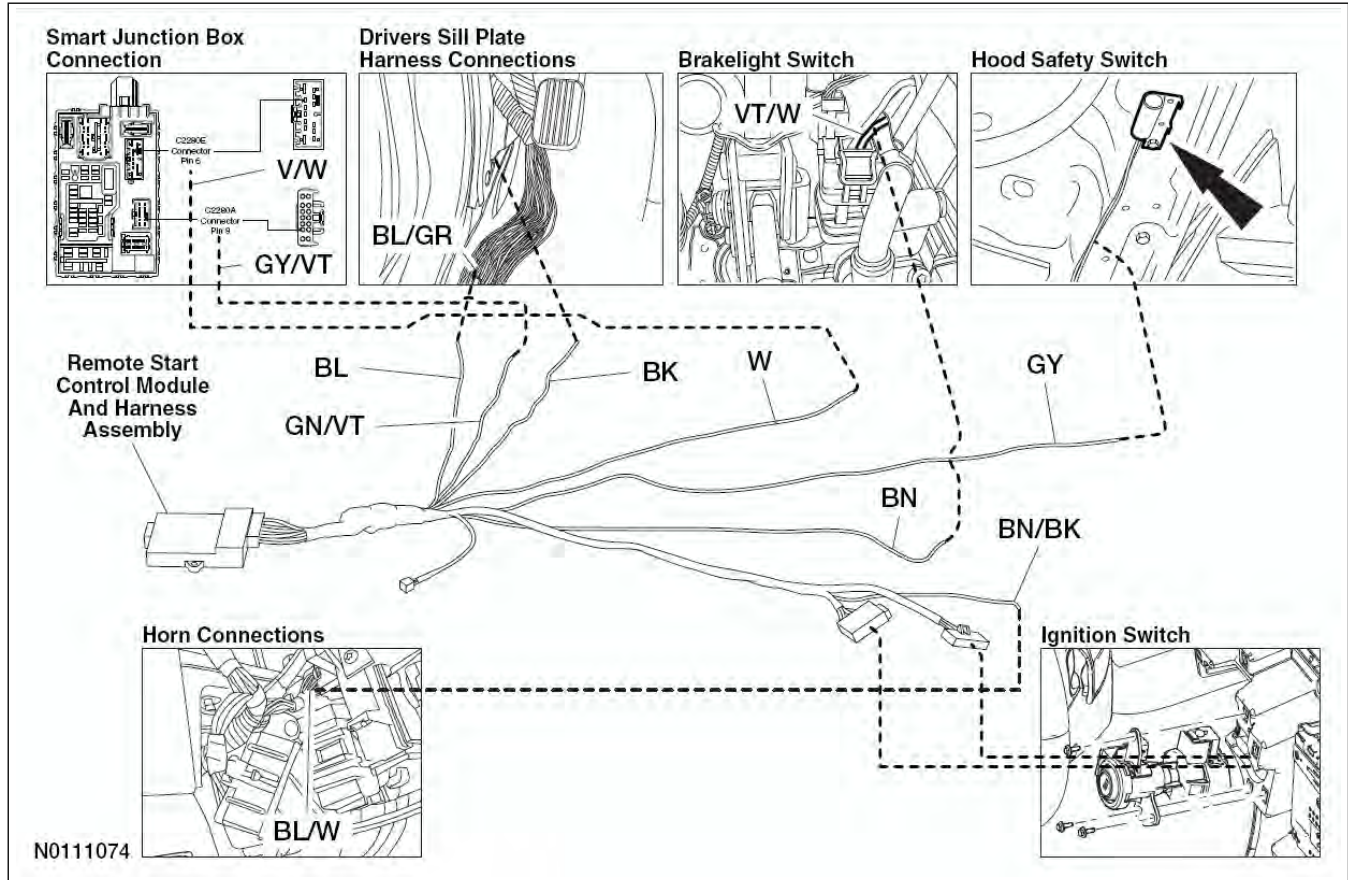

### Taurus - Non PEPS Only

**NOTICE:** Remote start systems are only applicable to vehicles with automatic transmissions.

**NOTE:** Both original keys are required for all remote start systems on vehicles equipped with SECURILOCK.

1. Verify correct kit number.

**INSTALLATION (Continued)**

**Review Remote Start Installation Kit Contents**

**NOTE:** Kits are vehicle specific and are not interchangeable.

2. Review the RMST kit contents.

**Remote Start System Standard Kit (RMST) Type - "A"**

QUANTITY	DESCRIPTION
1	TYPE - "A" MODULE ASSEMBLY
1	RMST SOFTWARE CARTRIDGE ASSEMBLY
2	1 BUTTON POWERCODE TRANSMITTER
1	TYPE - "A" CUSTOM WIRING HARNESS
1	ANTENNA
1	HOOD SAFETY SWITCH ASSEMBLY
1	INSTALLATION PARTS BAG
1	FUSE PARTS BAG
1	OPERATORS INSTRUCTIONS
1	OPERATORS QUICK REFERENCE WALLET CARD
1	UNDERHOOD WARNING LABEL
1	SECURILOCK INTERFACE KIT

3. Review the RMST bidirectional kit contents.

**Remote Start System Bidirectional Kit (RMST) Type - "A"**

QUANTITY	DESCRIPTION
1	TYPE - "A" MODULE ASSEMBLY
1	RMST SOFTWARE CARTRIDGE ASSEMBLY

**Remote Start System Bidirectional Kit (RMST) Type - "A" (Continued)**

QUANTITY	DESCRIPTION
1	2 BUTTON POWERCODE TRANSMITTER
1	TYPE - "A" CUSTOM WIRING HARNESS
1	ANTENNA
1	ANTENNA HARNESS
1	HOOD SAFETY SWITCH ASSEMBLY
1	INSTALLATION PARTS BAG
1	FUSE PARTS BAG
1	OPERATORS INSTRUCTIONS
1	OPERATORS QUICK REFERENCE WALLET CARD
1	UNDERHOOD WARNING LABEL
1	SECURILOCK INTERFACE KIT

**Module Preparation**

- Place the supplied fuses into the power distribution block on the remote start control module.
  - Move the polarity jumpers to their proper locations on the control module, see illustration.

**INSTALLATION (Continued)**

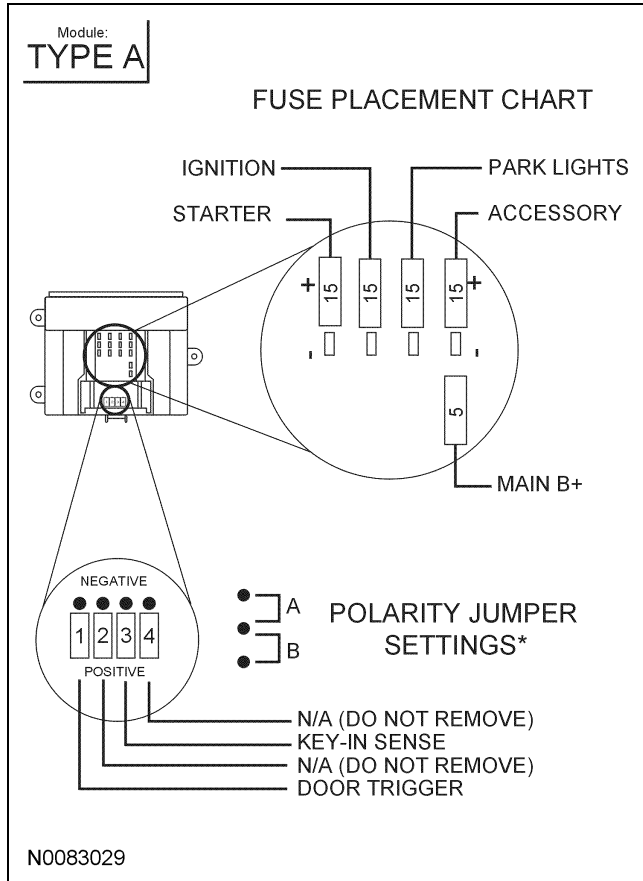

- Place the software cartridge onto the RMST control module.

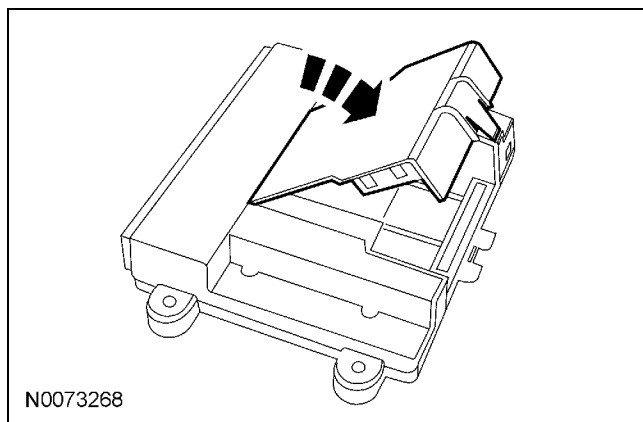

- Plug the wiring harness(es) into the module.
  - A - Harness: 24-way, used on all systems.
  - B - Harness: 10-way, used on all systems with RMST.

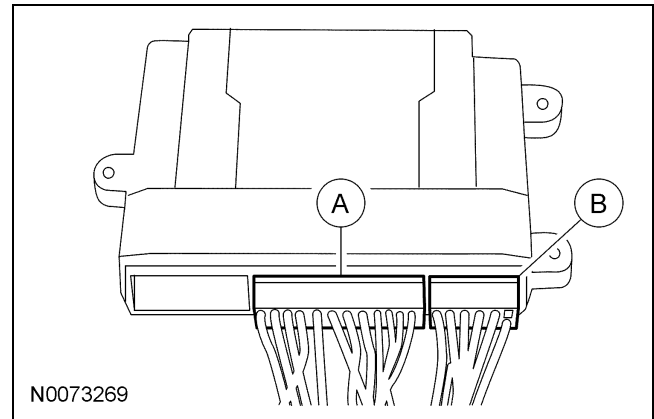

- NOTE:** Do not cut the override programming button off of the harness, it is used for all installations.

**NOTE:** For vehicle specific wiring diagram(s) [click here](#).

Referring to the vehicle specific wiring section for the system being installed, gather all individual wires that will be routed to the same areas of the vehicle into groups. Cover each wire group with electrical tape for approximately 18". Depending on the vehicle, there will be 2 to 5 different wire groups.

Trim the unused wires approximately 6 - 8" from the module.

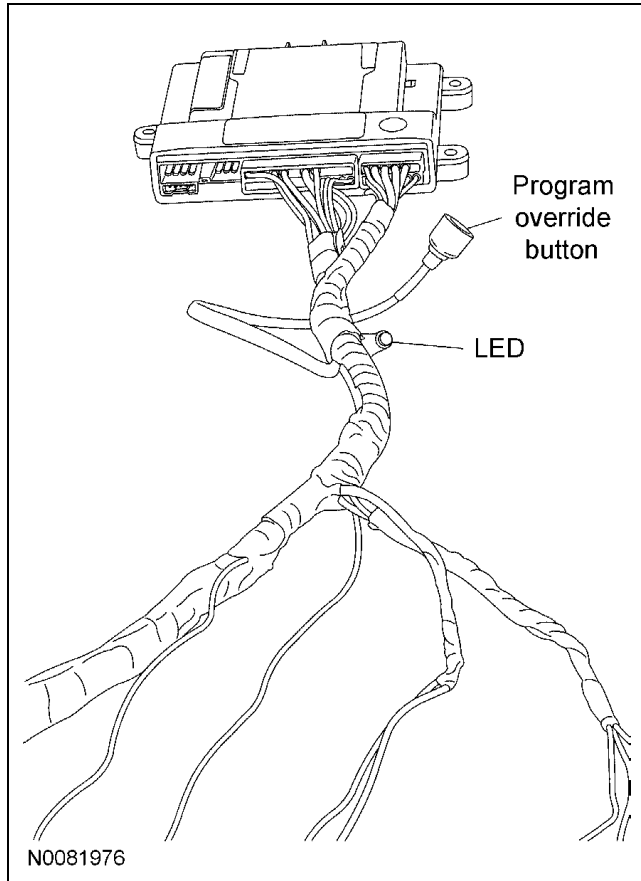
**INSTALLATION (Continued)**

8. Tape the harness sections together, making sure to cover all of the unused wires.

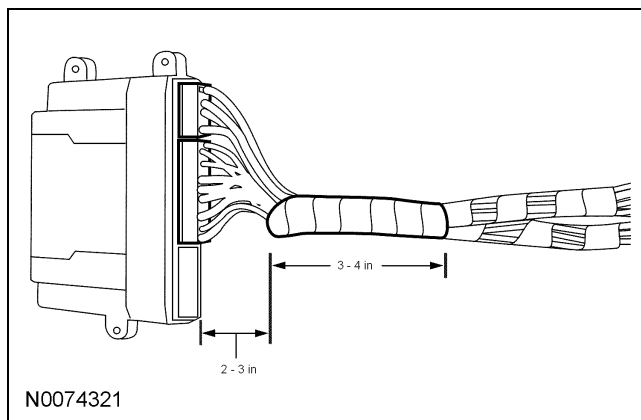
**Vehicle Preparation**

9. Remove the 2 lower instrument panel steering column cover screws and the cover.

10. Remove the 3 screws and the upper and lower steering column shrouds.
11. Remove the left hand scuff plate and cowl trim panel.
12. Remove the center stack, cupholders, and shifter trim panels.
13. Remove the instrument cluster trim and passenger instrument panel trim plate.
14. Remove the center console side trim pieces.

**Antenna Mounting**

**NOTE:** For good range of operation, the antenna must be installed correctly.

**NOTE:** Keep these points in mind when selecting a location and mounting the antenna.

- Do not mount the antenna behind or on any metal film or window tinting on the windshield.
  - Do not mount the antenna so that one of the antenna elements touches or crosses any vehicle wiring and/or metal.
  - On vehicles without metal film in the windshield around the rear view mirror, mount the antenna between the headliner and the rear view mirror.
  - On vehicles equipped with an electronic mirror, or on vehicles with metal film around the rearview mirror, mount the antenna approximately 3 inches below the mirror attachment point to the windshield and/or mirror electronics.
15. Choose a suitable mounting location following the guidelines above.

**Install The Antenna**

16. Clean the mounting surface using an alcohol base solution and a clean cloth.

**INSTALLATION (Continued)**

17. **NOTE:** Do not touch the adhesive, reduced adhesion may result.

**NOTE:** Make sure that the long wire on the antenna is pointing towards the top of the windshield since this wire will be routed along the headliner.

**NOTE:** The wire will be attached to the control module later in this procedure.

Remove the protective backing from the adhesive on the antenna and firmly press the body of the antenna to the windshield.

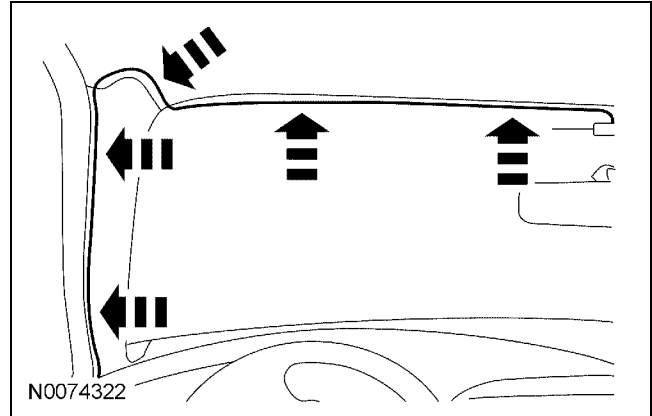

20. Reposition the A pillar trim panel.

**Install The Securilock Interface Kit**

21. Route the ring of the SECURILOCK interface antenna lead up along the steering column to the PATS transceiver location.

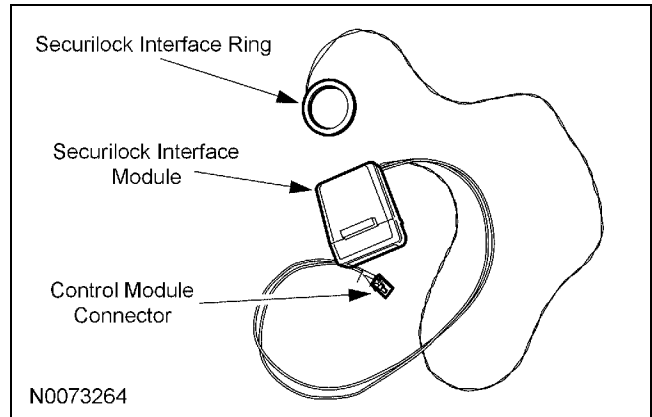
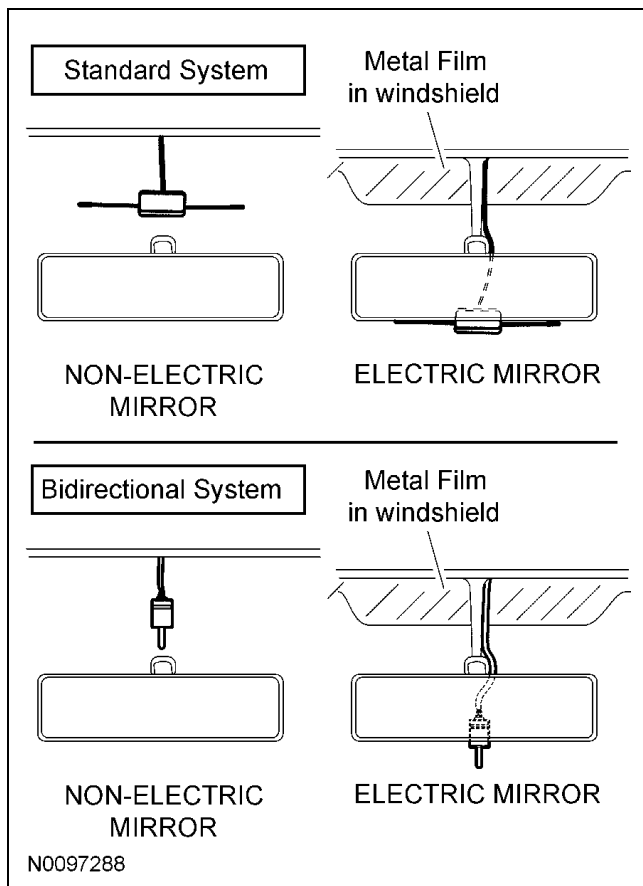

22. Following the directions on the supplied tube of adhesive primer, apply a thin coating around the transceiver antenna coil and allow to dry for approximately 5 minutes.

18. If necessary, position the A pillar trim slightly outward to provide access to route the antenna wire.

**NOTE:** Do not route the antenna wire over the top of the air bag.

19. Route the antenna cable along the headliner and down the A pillar towards the floor.

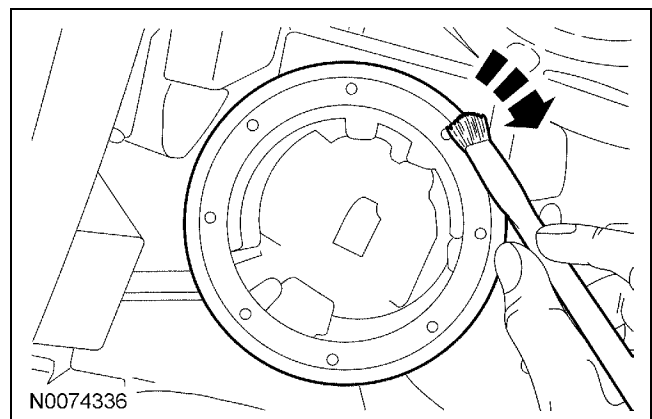

**INSTALLATION (Continued)**

23. **NOTICE:** Do not damage the transceiver ring during installation or while installing the steering column shroud.

A damaged transceiver ring will result in an inoperable remote start system.

Remove the protective backing from the SECURILOCK antenna ring. Place the SECURILOCK ring over the PATS transceiver and press firmly in place.

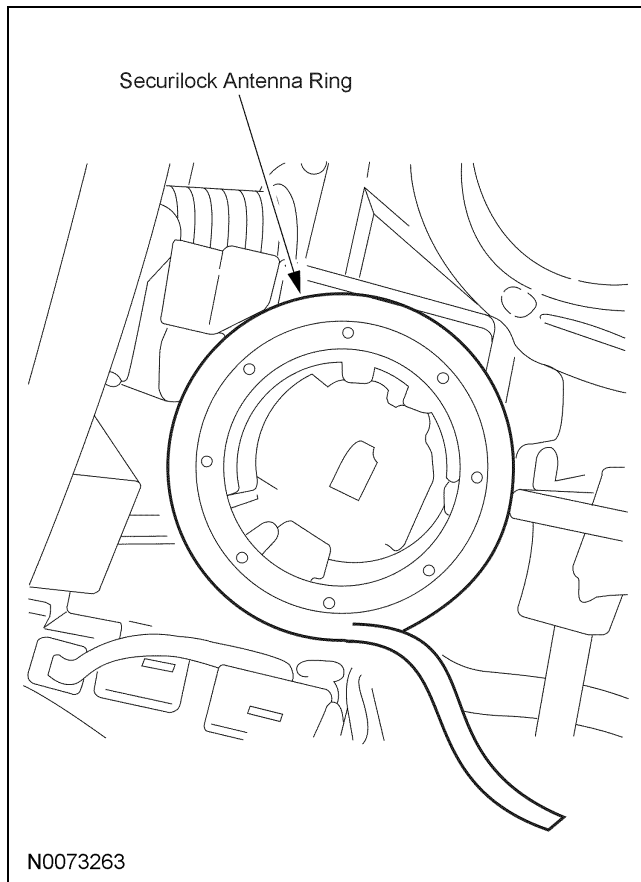
**Install The Securilock Interface Module**

24. **NOTE:** Do Not mount the SECURILOCK Interface Module to or within 3" of a metal surface, including any underdash brackets, or in the knee bolster area.

Mount the SECURILOCK Interface Module to an underdash wiring harness using one of the supplied long tie wraps.

25. **NOTICE:** Do not attach the harness to the steering column.

Route the harness and connector the to module mounting location.

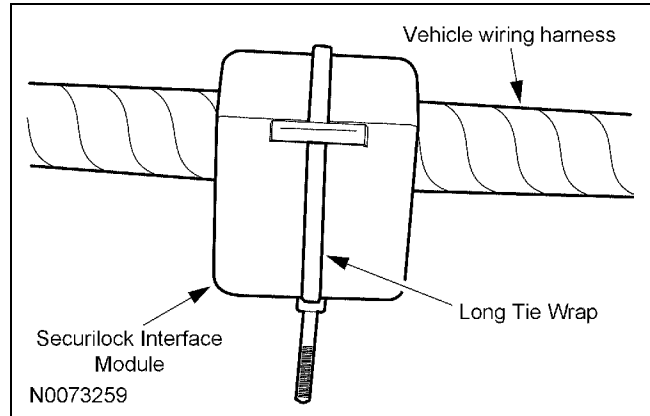
**Install the Remote Start Control Module and Harness Assembly**

26. Place the remote start module and harness assembly on the floor of the vehicle.

**Identify Circuit Wires For Connections**

**NOTE:** For vehicle specific wiring diagram(s) click [here](#).

**NOTE:** For proper wire splicing techniques click [here](#).

27. Connect the Black ground wire from the remote start module harness to the chassis ground point at the driver kick panel.

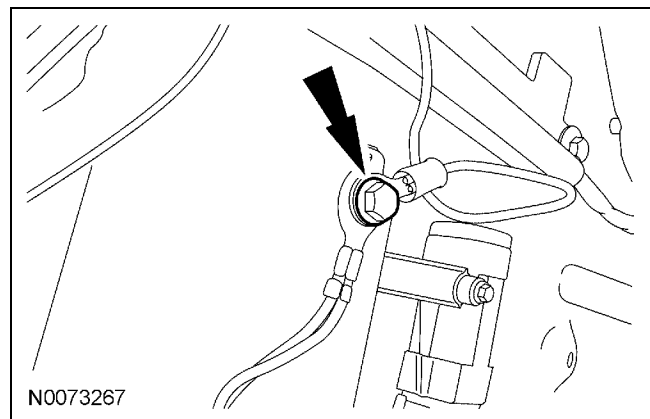

28. Disconnect the ignition switch electrical connector.
29. Connect the remote start harness hard shell connectors to the ignition switch and ignition switch connector



**INSTALLATION (Continued)**

30. **NOTE:** A DVOM connected to the correct wire will show 12V, then show 0V when the horn button is held.

A logic probe will show power on the correct wire, then show ground when the horn button is held.

Identify the Blue/White horn circuit wire in the steering column harness.

31. Connect the Brown/Black wire from the remote start module harness to the Blue/White horn circuit wire in the steering column harness.

32. **NOTE:** This connection is not required for vehicles equipped with memory seats.

**NOTE:** A DVOM connected to the correct wire will show 12V, then show 0V when the door lock switch is pressed.

A logic probe will show power on the correct wire, then show ground when the door lock switch is pressed.

Identify the Blue/Green power door lock circuit wire at the driver kick panel harness.

33. **NOTE:** This connection is not required for vehicles equipped with memory seats.

Connect the Blue wire from the remote start module harness to the Blue/Green wire at the driver kick panel harness.

34. **NOTE:** A DVOM connected to the correct wire will show 12V with the vehicle door(s) open and the dome light on, then show 0V with the vehicle door(s) closed and the dome light off.

**NOTE:** A logic probe connected to the correct wire will show power with the vehicle door(s) open and the dome light on, then show ground with the vehicle door(s) closed and the dome light off.

**NOTE:** Be sure that the dome light has timed out and is off before performing the door closed test.

Be sure that the dome lamp is illuminated before performing the door open test.

Identify the Grey/Violet dome light circuit wire at the Smart Junction Box SJB C2280A Connector Pin 9.

35. Connect the Green/Violet wire from the remote start module harness to the Grey/Violet dome light circuit wire at the SJB C2280A Connector Pin 9.

36. **NOTE:** A DVOM connected to the correct wire will show 0V, then show 12V while depressing the brake pedal.

A logic probe will show ground when on the correct wire, then show power while depressing the brake pedal.

Identify the Violet/White brake switch circuit wire at the brake switch.

37. Connect the Brown wire from the remote start module harness to the Violet/White brake switch circuit wire at the brake switch.

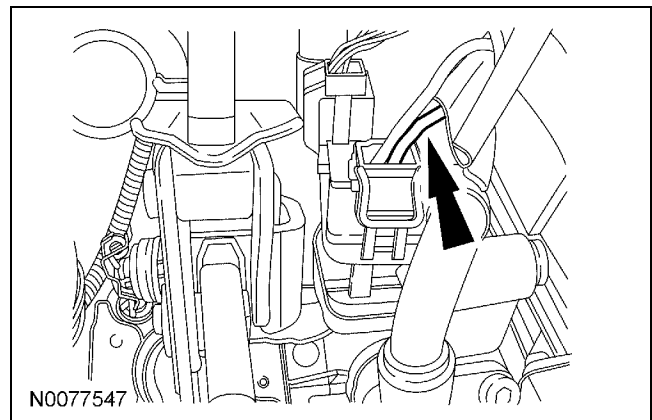

38. **NOTE:** A DVOM connected to the correct wire will show 12V, when the headlight switch is ON, then show 0V when the headlight switch is OFF.

A logic probe will show power on the correct wire when the headlight switch is ON, then show ground when the headlight switch is OFF.

Identify the Violet/White parking light circuit wire at the SJB C2280E Connector Pin 6.

39. Connect the White wire from the remote start module harness to the Violet/White parking light circuit wire at the SJB C2280E Connector Pin 6.

**INSTALLATION (Continued)**

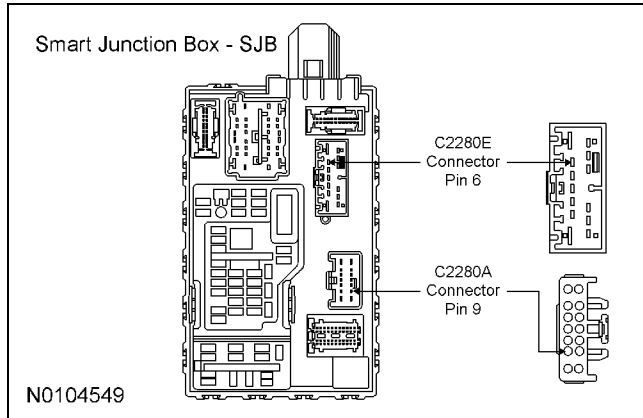

**Install The Hood Safety Switch**

40. **NOTE:** Route the hood safety switch wire carefully avoiding any moving parts or components that can produce excessive heat.
- NOTE:** Using a piece of convolute adds in the appearance of the installation.
- NOTE:** The switch should be positioned about 30 degrees below parallel to the ground to accommodate for parking on inclines.
- Failure to position the switch properly could result in one of the following:

- False alarm trips
- Non-Remote Start events
- Inadvertent shutdown during Remote Start

Locate an easy to access area near the driver side hood hinge and install the hood safety switch using the supplied metal screws.

41. Apply rustproofing compound (PM-13-A) to the drilled hole and torque the screw to 1.00 Nm (10 lb-in).

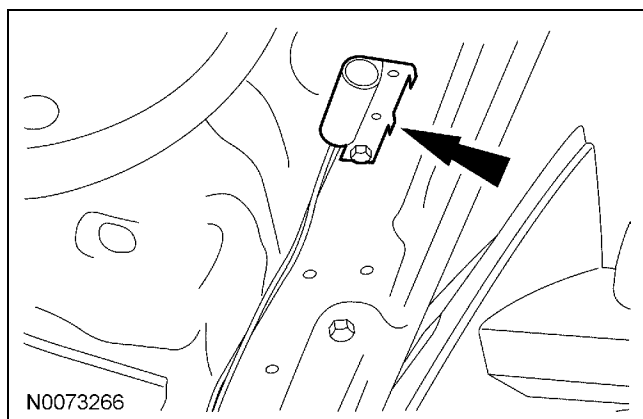

42. Connect hood switch ground wire to a suitable location on the bulkhead.

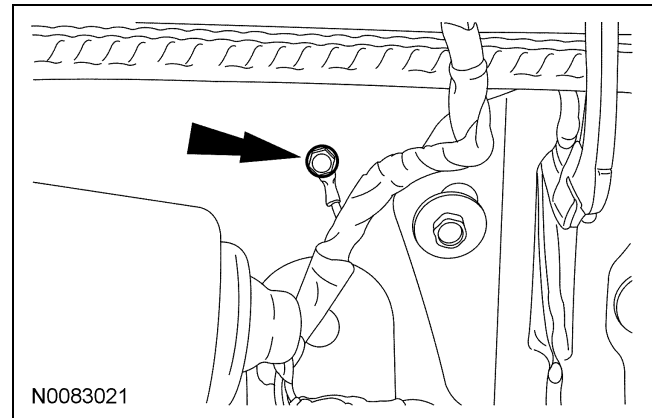

43. **NOTE:** Place the label on the radiator fan shroud or similar area.

Install the underhood warning label

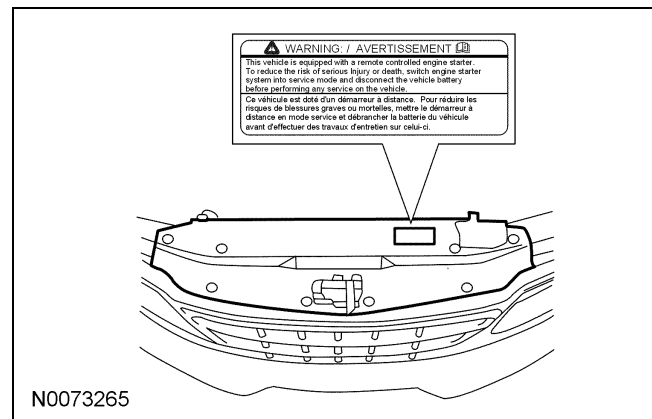

44. Route the Gray hood safety switch wire through the bulkhead into the engine compartment and attach to the hood safety switch.

45. Connect the antenna to the RMST control module.

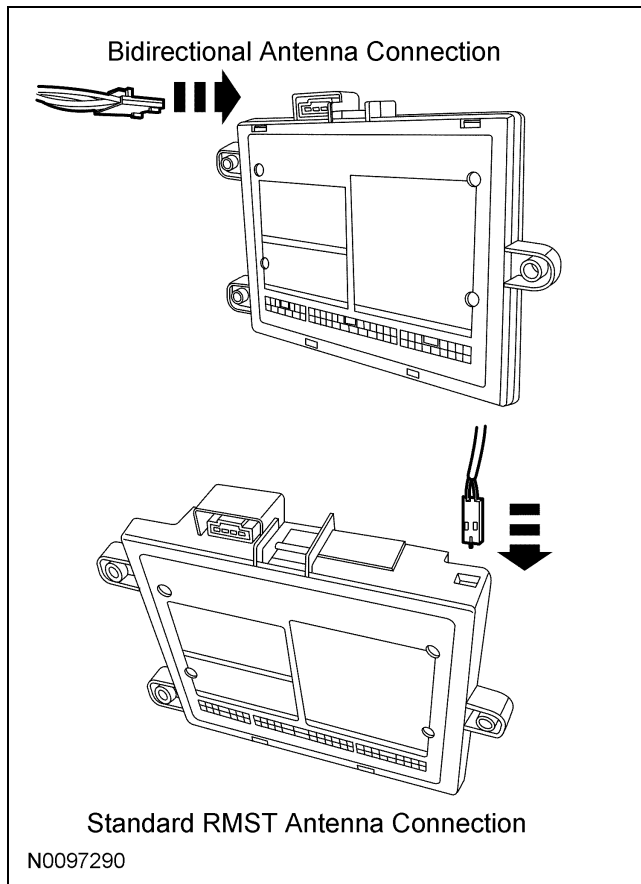
**INSTALLATION (Continued)**

46. Connect the SECURILOCK interface module to the RMST control module.

**Program The RMST System**

47. [Refer to the RMST programming section for this vehicle click here.](#)

**Secure RMST Harness and Control Module**

48. Use the supplied tie wraps to secure the RMST harness wires.

49. **NOTE:** Do not mount the control module in the knee bolster area.

Secure the control module at three points to the vehicle.

Use the supplied long tie wraps to mount the RMST control module to the underdash wiring harness.

**Install Trim**

50. Install the center console side trim pieces.
51. Install the instrument cluster trim and passenger instrument panel trim plate.
52. Install the center stack, cupholders, and shifter trim panels.
53. Install the left hand scuff plate and cowl trim panel.
54. Install the upper and lower steering column shrouds.  
Install the 3 screws.
55. Install the lower steering column opening cover.  
Install the 2 screws.
- Tighten to 9 Nm (80 lb-in).

## GENERAL PROCEDURES

### Programming - Standard Remote Start

#### Programming the Module

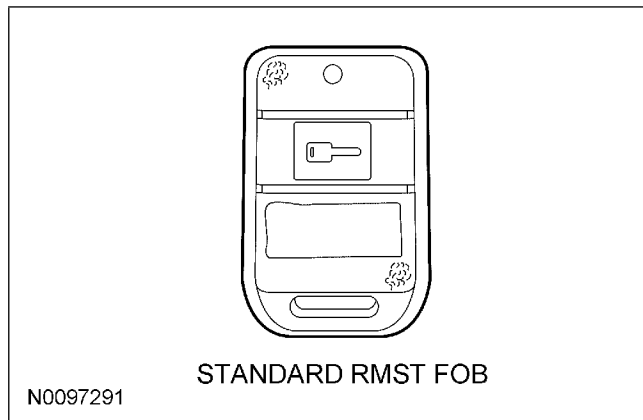

- NOTE:** If the remote start options (Key-in sense polarity, door ajar polarity, or tach mode) are not programmed correctly, vehicle will not remote start or operate properly.

**NOTE:** Make sure that the hood and doors are closed before proceeding.

**NOTE:** The LED on the remote start harness must be visible to complete module programming.

**NOTE:** The remote start override button must be accessible.

#### Programming Options: Entering Programming Mode

- See chart below for programming information.

#### Program Bank 2 Chart (5 Honks)

BANK	OPTIONS	DESCR	LED
2	1	TACHLESS MODE	ON

- Press and hold the brake pedal.
- Turn the ignition key to the RUN position.  
The dome light will turn off.

- Press and hold the remote start system override button for at least 10 seconds.

After 10 seconds the horn will honk 3 times, indicating the system is now in the learn mode.

Release the brake pedal and the RMST override button.

- Press and release the override button. The horn will honk 4 times indicating the system has entered the first program bank.

If not, please check the following:

- Brake pedal switch wire solder connection.
- Hood closed and Grey hood safety switch wire solder connection.
- All doors closed and dome light circuit wire solder connections.
- The key is in the RUN position.
- The software cartridge is firmly seated in the RMST module.
- The RMST harness connections are firmly seated in the RMST module.

**NOTE:** If you require additional assistance: CALL 1-800-FORD KEY.

- Press and release the override button again. The horn will honk 5 times indicating the system has entered the second program bank.
- Press and release the brake pedal.  
The horn will honk 1 time indicating the system has entered the option 1 of the second program bank.

**NOTICE:** When turning LED on or off using remote start fob button quickly press and immediately release the remote start button.

**Failure to quickly release the remote start fob button will result in system defaulting to the factory options.**

- The LED must be on for option 1. If the LED is illuminated no action is required. If the LED is not illuminated press the remote start fob button and verify the LED illuminates.

**GENERAL PROCEDURES (Continued)**

**NOTE:** If the remote start fob button is held for more than 3 seconds the system will chirp the horn 4 times, indicating the system has returned to factory default settings. If this occurs return to step 1 of the programming section and reprogram the remote start module.

**NOTE:** The remote start module is now programmed.

10. Remove the ignition key.

**Programming the SECURILOCK**

**NOTE:** Two PATS keys are required to program the SECURILOCK.

**NOTE: IMPORTANT:** Each of the following steps should be completed with no more than 5 seconds delay between steps.

11. Insert the first ignition key and turn to the run position.

Watch for the PATS light to turn off. Remove the first key.

12. Insert the second ignition key and turn to the run position.

Watch for the PATS light to turn off. Remove the second key.

13. Press and hold the remote start button



for 3 seconds.  
The PATS light should stay on for 3-5 seconds before turning off, which means that the SECURILOCK was successfully programmed.

**NOTE:** If the PATS light blinks rapidly, repeat steps 1-3 to retry programming the SECURILOCK.

**NOTE:** The engine will start if the Remote Start kit has been installed correctly, the brake is not depressed, and the hood and doors are closed.

## GENERAL PROCEDURES

### Functional Test - Standard Remote Start

**NOTE:** If during any of the steps of the functional test, the remote start system or vehicle doesn't react or perform accordingly, please refer to the remote start troubleshooting guide.

**NOTE:** For remote start troubleshooting guide click [here](#).

1. Make sure all doors are closed but hood is open and windows are down (doors will be locking).
2. Press and hold the Start button on the remote control key fob for 2-3 seconds - Horn should honk once indicating receipt of the start request.
3. The remote start systems should turn on the ignition, but then honk the horn twice and shut down indicating the hood is open.
4. Close the hood, and insert a key into the ignition switch.
5. Attempt to re-start the vehicle again using the key fob.
6. The remote start systems should turn on the ignition, but then honk the horn five times and shut down indicating a key is in the ignition switch.
7. Remove the key and open a door.
8. Attempt to re-start the vehicle again using the key fob.
9. The remote start systems should turn on the ignition, but then honk the horn three times and shut down indicating a door is open.
10. Close the door.
11. Attempt to re-start the vehicle again using the key fob.

12. Once the vehicle starts, verify that all heat and A/C functions operate normally and that the doors have locked.
13. On vehicles equipped with power window interrupt, Attempt to close windows to check power window interrupt function.
14. Once all systems have been checked, open the door\*, or press the brake pedal - the remote start systems should shut down.

**NOTE:** \*MyKey vehicle remote start systems will shut down upon vehicle entry. Please see vehicle owner's guide or remote start owner's manual for more information.

### Troubleshooting

15. **NOTE:** When attempting to remote start your vehicle, the system has several safety checks that it performs. If any of these inputs are present that should not be, the system will respond back to you with several horn "chirps" to help you identify which input is present. These "chirps" will occur after initiating a start sequence with the transmitter, the system will turn on the ignition, but then respond back with several horn "chirps" and abort the starting process.

**Example:** Depress the remote start fob button for 3 seconds and then release. The vehicle horn will "chirp" one time to indicate that RMST signal was received. If the vehicle doesn't start and the horn "chirps" 3 times, there is a fault - "Vehicle Door is Open"

CHIRPS	PROBLEM
1 Chirp	SECURILOCK not programmed correctly, or the SECURILOCK antenna ring is damaged.
2 Chirps	BRAKE is being pressed, or the HOOD is open.
3 Chirps	One of the vehicles DOORS are open.
4 Chirps	TACH not programmed.

**GENERAL PROCEDURES (Continued)**

---

<b>CHIRPS</b>	<b>PROBLEM</b>
5 Chirps	The KEY is in the ignition.
6 Chirps	The remote start system is in SERVICE/VALET mode.

---

## GENERAL PROCEDURES

### Programming - Bidirectional Remote Start

#### Programming the Module

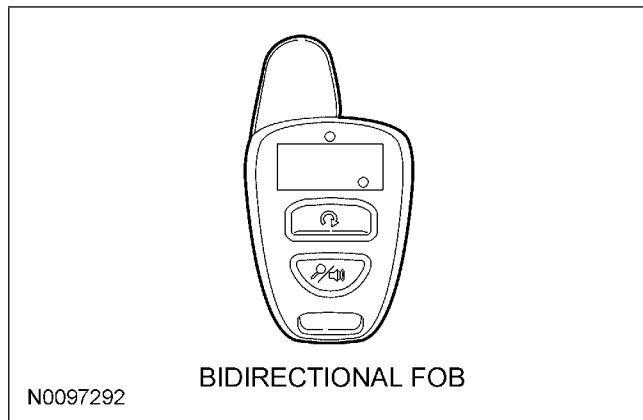

- NOTE:** If the remote start options (Key-in sense polarity, door ajar polarity, or tach mode) are not programmed correctly, vehicle will not remote start or operate properly.

**NOTE:** Make sure that the hood and doors are closed before proceeding.

**NOTE:** The LED on the remote start harness must be visible to complete module programming.

**NOTE:** The remote start override button must be accessible.

#### Programming Options: Entering Programming Mode

- See chart below for programming information.

#### Program Bank 2 Chart (5 Honks)

BANK	OPTIONS	DESCR	LED
2	1	TACHLESS MODE	ON

- Press and hold the brake pedal.
- Turn the ignition key to the RUN position.  
The dome light will turn off.

- Press and hold the remote start system override button for at least 10 seconds.

After 10 seconds the horn will honk 3 times, indicating the system is now in the learn mode.

Release the brake pedal and the RMST override button.

- Press and release the override button. The horn will honk 4 times indicating the system has entered the first program bank.

If not, please check the following:

- Brake pedal switch wire solder connection.
- Hood closed and Grey hood safety switch wire solder connection.
- All doors closed and dome light circuit wire solder connections.
- The key is in the RUN position.
- The software cartridge is firmly seated in the RMST module.
- The RMST harness connections are firmly seated in the RMST module.

**NOTE:** If you require additional assistance: CALL 1-800-FORD KEY.

- Press and release the override button again. The horn will honk 5 times indicating the system has entered the second program bank.

- Press and release the brake pedal.  
The horn will honk 1 time indicating the system has entered the option 1 of the second program bank.

**NOTICE:** When turning LED on or off using remote start fob button quickly press and immediately release the remote start button.

**Failure to quickly release the remote start fob button will result in system defaulting to the factory options.**

- The LED must be on for option 1. If the LED is illuminated no action is required. If the LED is not illuminated press the remote start fob button and verify the LED illuminates.



**GENERAL PROCEDURES (Continued)**

**NOTE:** If the remote start fob button is held for more than 3 seconds the system will chirp the horn 4 times, indicating the system has returned to factory default settings. If this occurs return to step 1 of the programming section and reprogram the remote start module.

**NOTE:** The remote start module is now programmed.

10. Remove the ignition key.

**Programming the SECURILOCK**

**NOTE:** Two PATS keys are required to program the SECURILOCK.

**NOTE: IMPORTANT:** Each of the following steps should be completed with no more than 5 seconds delay between steps.

11. Insert the first ignition key and turn to the run position.

Watch for the PATS light to turn off. Remove the first key.

12. Insert the second ignition key and turn to the run position.

Watch for the PATS light to turn off. Remove the second key.

13. Press the remote start button  twice within 3 seconds.

The PATS light should stay on for 3-5 seconds before turning off, which means that the SECURILOCK was successfully programmed.

**NOTE:** If the PATS light blinks rapidly, repeat steps 1-3 to retry programming the SECURILOCK.

**NOTE:** The engine will start if the Remote Start kit has been installed correctly, the brake is not depressed, and the hood and doors are closed.

## GENERAL PROCEDURES

### Functional Test - Bidirectional Remote Start

**NOTE:** If during any of the steps of the functional test, the remote start system or vehicle doesn't react or perform accordingly, please refer to the remote start troubleshooting guide.

**NOTE:** For remote start troubleshooting guide click [here](#).

1. Make sure all doors are closed but hood is open and windows are down (doors will be locking).
2. Press the Start button on the remote control key fob twice within 3 seconds - Horn should honk once indicating receipt of the start request.
3. The remote start systems should turn on the ignition, but then honk the horn twice and shut down indicating the hood is open.
4. Close the hood, and insert a key into the ignition switch.
5. Attempt to re-start the vehicle again using the key fob.
6. The remote start systems should turn on the ignition, but then honk the horn five times and shut down indicating a key is in the ignition switch.
7. Remove the key and open a door.
8. Attempt to re-start the vehicle again using the key fob.
9. The remote start systems should turn on the ignition, but then honk the horn three times and shut down indicating a door is open.
10. Close the door.
11. Attempt to re-start the vehicle again using the key fob.

12. Once the vehicle starts, verify that all heat and A/C functions operate normally and that the doors have locked.
13. On vehicles equipped with power window interrupt, Attempt to close windows to check power window interrupt function.
14. Once all systems have been checked, open the door\*, or press the brake pedal - the remote start systems should shut down.

**NOTE:** \*MyKey vehicle remote start systems will shut down upon vehicle entry. Please see vehicle owner's guide or remote start owner's manual for more information.

### Troubleshooting

15. **NOTE:** When attempting to remote start your vehicle, the system has several safety checks that it performs. If any of these inputs are present that should not be, the system will respond back to you with several horn "chirps" to help you identify which input is present. These "chirps" will occur after initiating a start sequence with the transmitter, the system will turn on the ignition, but then respond back with several horn "chirps" and abort the starting process.

**Example:** Depress the remote start fob button for 3 seconds and then release. The vehicle horn will "chirp" one time to indicate that RMST signal was received. If the vehicle doesn't start and the horn "chirps" 3 times, there is a fault - "Vehicle Door is Open"

CHIRPS	PROBLEM
1 Chirp	SECURILOCK not programmed correctly, or the SECURILOCK antenna ring is damaged.
2 Chirps	BRAKE is being pressed, or the HOOD is open.
3 Chirps	One of the vehicles DOORS are open.
4 Chirps	TACH not programmed.

# '11 Taurus - Key Start

TYPE "A" CUSTOM WIRE HARNESS

RMST MODULE WIRE HARNESS

VEHICLE HARNESS

IGNITION SWITCH

## STEERING COLUMN HARNESS

	Color	Function
A-3	PINK	Ignition Input/Output
A-2	ORANGE	HVAC Output
A-13	VIOLET	Starter Output
B-8	BLACK/WHITE	Key-in-sense Input
A-4	RED	Battery

	Color	Function
A-21	BROWN/BLACK	Horn Relay Output

## DRIVER'S KICK PANEL HARNESS

	Color	Function
A-5	BLACK	Ground
A-24	BLUE	Door Lock Output
B-7	BROWN	Brake Input
A-20	GREEN/VIOLET	Door Ajar Switch Input

## HEADLAMP SWITCH HARNESS

	Color	Function
A-1	WHITE	Parking Light Output

## UNDER HOOD HARNESS

	Color	Function
A-19	GRAY	Hood Open Switch Input

Vehicle Interior

Engine Compartment

Chassis Ground



Do Not Ground to Hood

Hood Tilt Switch

Horn (BLUE/WHITE)

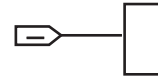

STEERING COLUMN HARNESS

MAKE THIS CONNECTION FIRST!

CHASSIS GROUND POINT IN DRIVER'S KICK PANEL



Door Lock\* ((BLUE/GREEN)

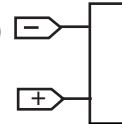

DRIVERS KICK PANEL

Brake Switch (VIOLET/WHITE)



SJB C2280A PIN 9

Dome Light (GRAY/VIOLET)



Parking Lights On (VIOLET/WHITE)



SJB C2280E PIN 6

\* Not Applicable on vehicles with memory seats

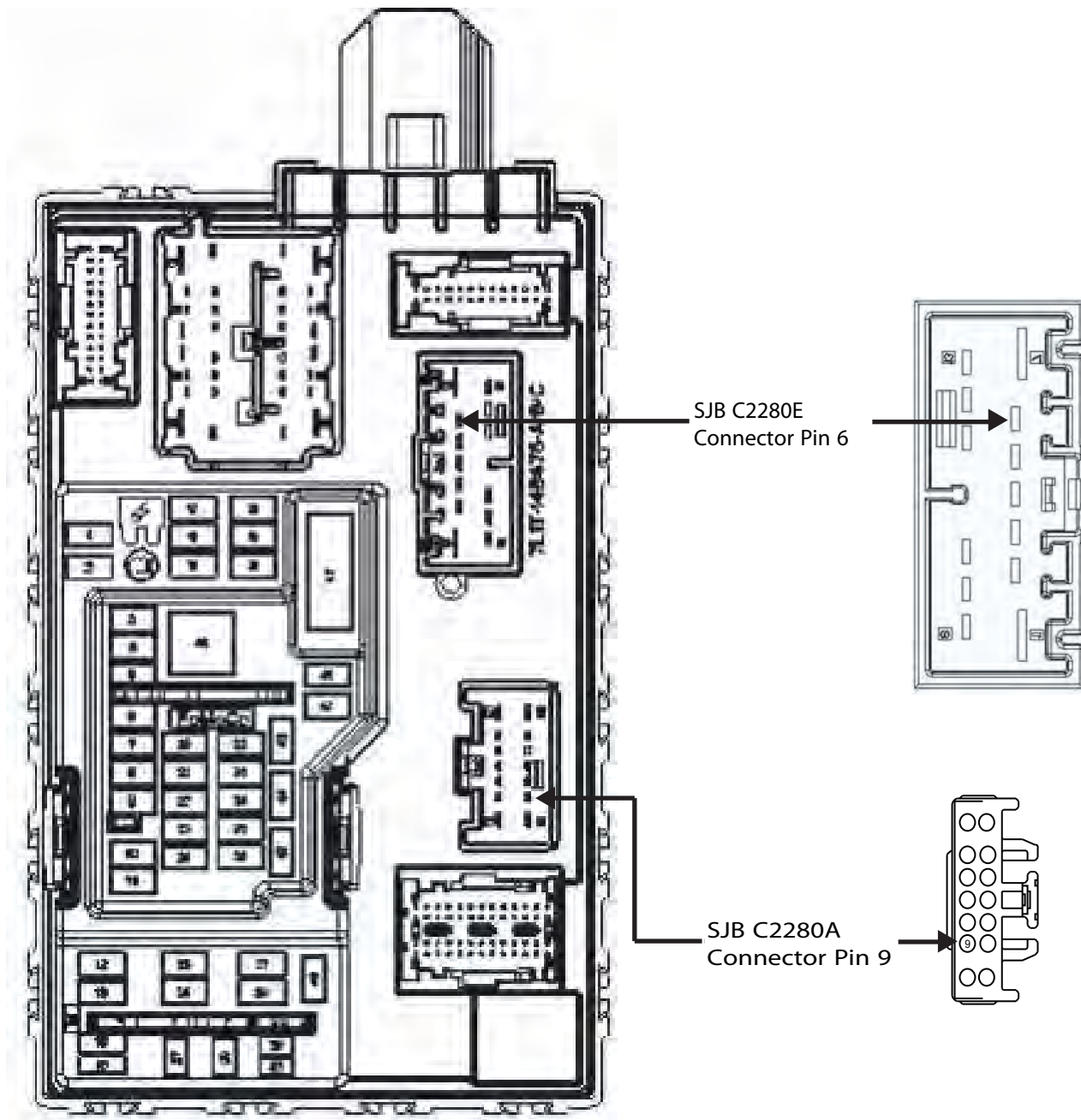

# REMOTE START SYSTEM INSTALLATION

## CONTENTS

### INSTALLATION

[Remote Start](#)

[Programming - Spare Intelligent Access \(IA\)Keys](#)

### GENERAL PROCEDURES

[Proper Splicing Techniques](#)

[Functional Test](#)

[Troubleshooting](#)

### WIRING DIAGRAMS

[Vehicle Specific Wiring Diagrams](#)

# INSTALLATION

## Remote Start — MKS

### Remote Start System RMST Components

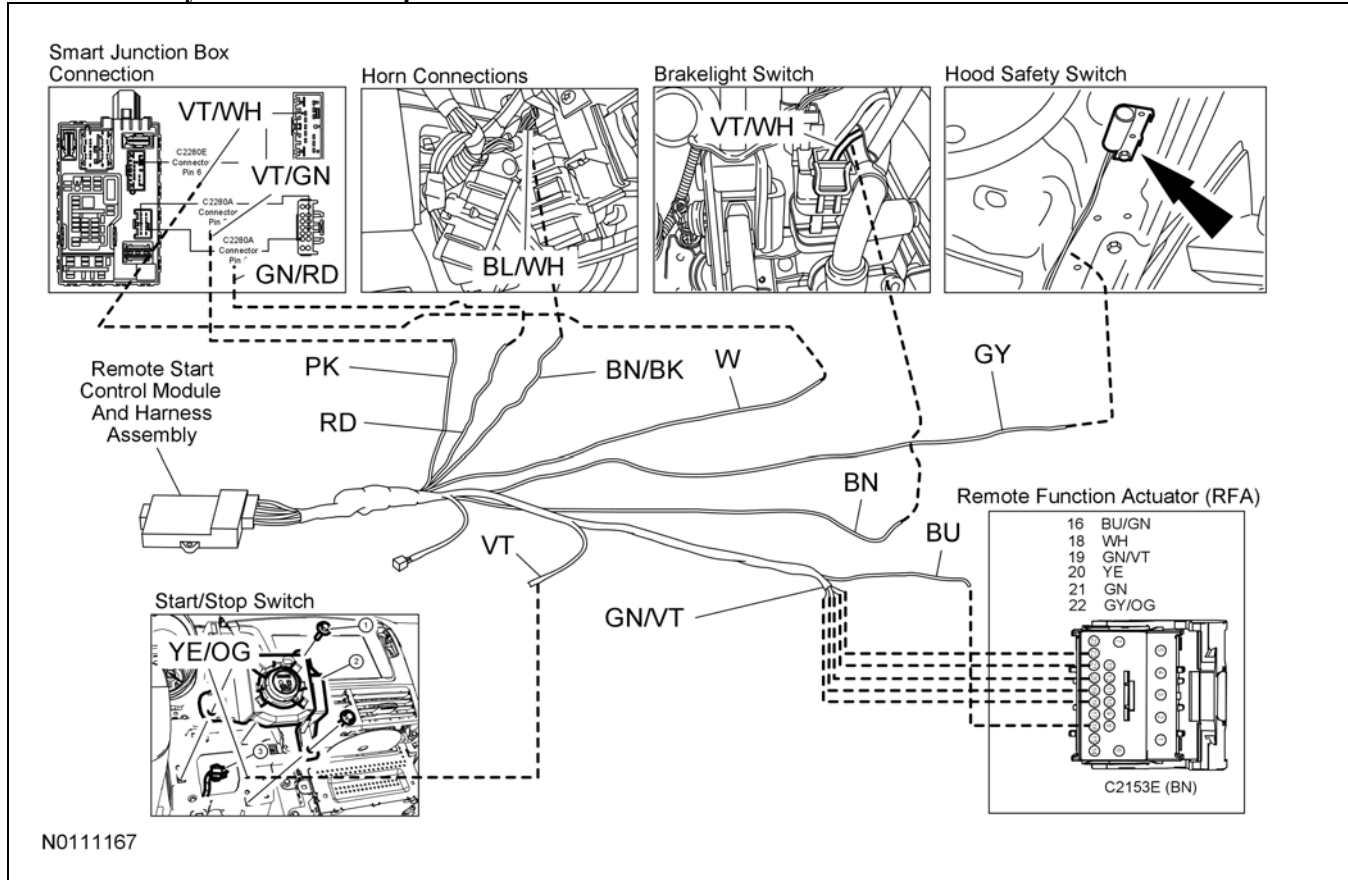

## MKS

**NOTICE:** Remote start systems are only applicable to vehicles with automatic transmissions.

**NOTE:** Both original keys are required for all remote start systems.

1. Verify correct kit number.

**INSTALLATION (Continued)**

**Review Remote Start Installation Kit Contents**

**NOTE:** Kits are vehicle specific and are not interchangeable.

2. Review the RMST kit contents.

**Remote Start System Standard Kit (RMST) Type - "A"**

QUANTITY	DESCRIPTION
1	TYPE - "A" MODULE ASSEMBLY
1	RMST SOFTWARE CARTRIDGE ASSEMBLY
2	1 BUTTON POWERCODE TRANSMITTER
1	TYPE - "A" CUSTOM WIRING HARNESS
1	ANTENNA
1	HOOD SAFETY SWITCH ASSEMBLY
1	INSTALLATION PARTS BAG
1	FUSE PARTS BAG
1	OPERATORS INSTRUCTIONS
1	OPERATORS QUICK REFERENCE WALLET CARD
1	UNDERHOOD WARNING LABEL
1	PEPS INTERFACE MODULE

3. Review the RMST bidirectional kit contents.

**Remote Start System Bidirectional Kit (RMST) Type - "A"**

QUANTITY	DESCRIPTION
1	TYPE - "A" MODULE ASSEMBLY
1	RMST SOFTWARE CARTRIDGE ASSEMBLY

**Remote Start System Bidirectional Kit (RMST) Type - "A" (Continued)**

QUANTITY	DESCRIPTION
1	2 BUTTON POWERCODE TRANSMITTER
1	TYPE - "A" CUSTOM WIRING HARNESS
1	ANTENNA
1	ANTENNA HARNESS
1	HOOD SAFETY SWITCH ASSEMBLY
1	INSTALLATION PARTS BAG
1	FUSE PARTS BAG
1	OPERATORS INSTRUCTIONS
1	OPERATORS QUICK REFERENCE WALLET CARD
1	UNDERHOOD WARNING LABEL
1	PEPS INTERFACE MODULE

**Module Preparation**

4. Place the supplied fuses into the power distribution block on the remote start control module.
  - Move the polarity jumpers to their proper locations on the control module, see illustration.

**INSTALLATION (Continued)**

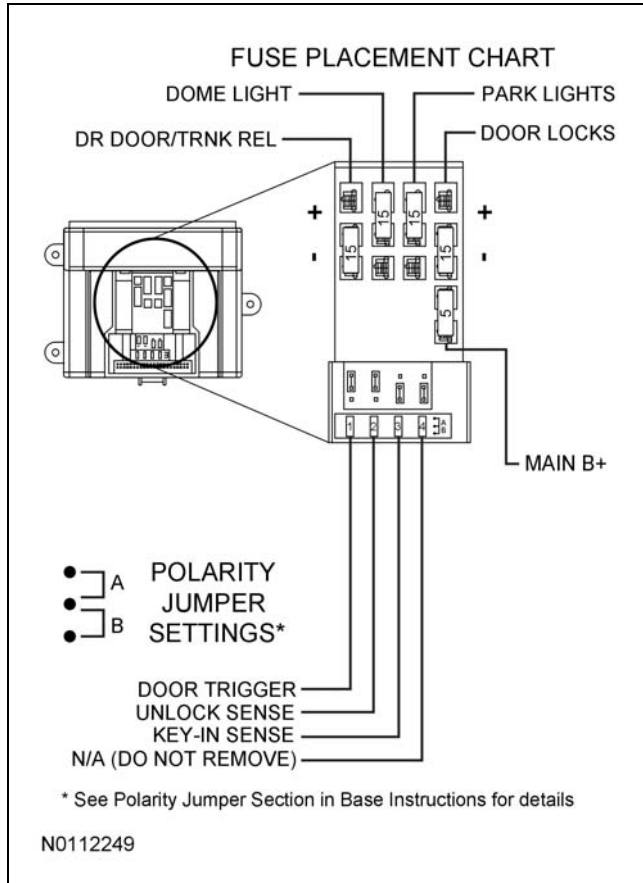

- Place the software cartridge onto the RMST control module.

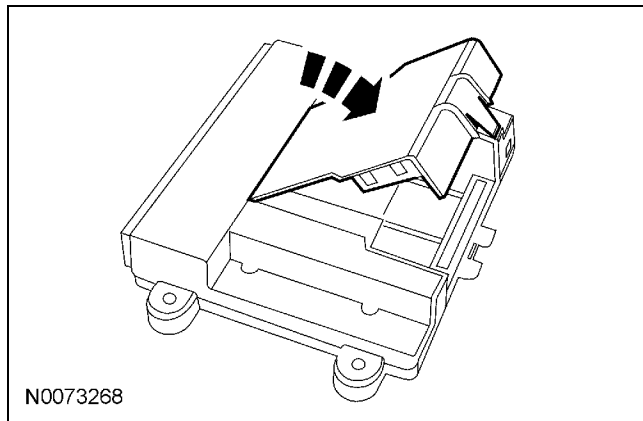

- Plug the wiring harness(es) into the module.
  - A - Harness: 24-way, used on all systems.
  - B - Harness: 10-way, used on all systems with RMST.

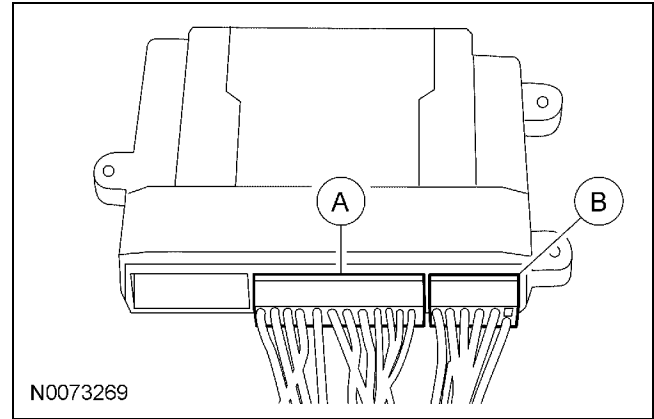

- NOTE:** Do not cut the override programming button off of the harness, it is used for all installations.

**NOTE:** For vehicle specific wiring diagram(s) click [here](#).

Referring to the vehicle specific wiring section for the system being installed, gather all individual wires that will be routed to the same areas of the vehicle into groups. Cover each wire group with electrical tape for approximately 18". Depending on the vehicle, there will be 2 to 5 different wire groups.

Trim the unused wires approximately 6 - 8" from the module.



## INSTALLATION (Continued)

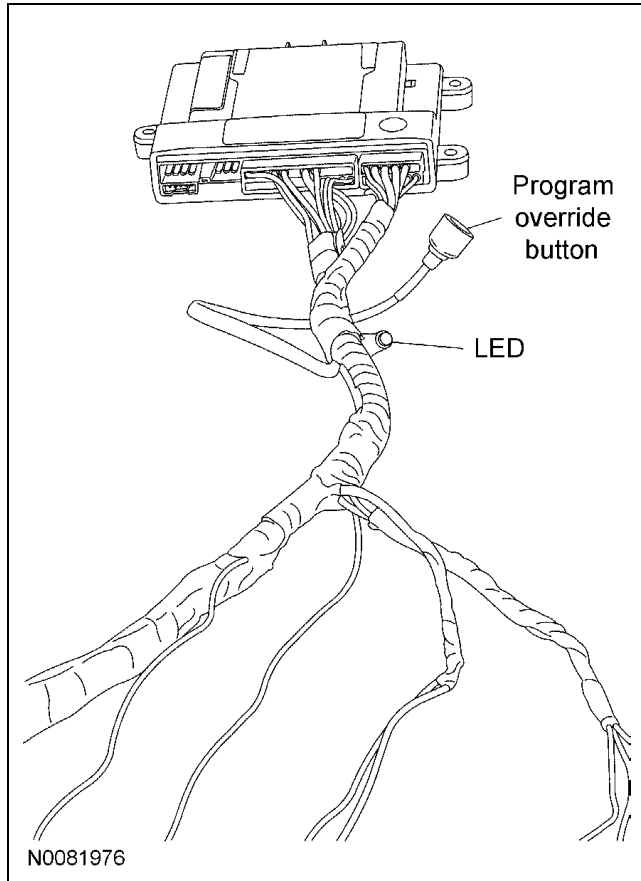

8. Tape the harness sections together, making sure to cover all of the unused wires.

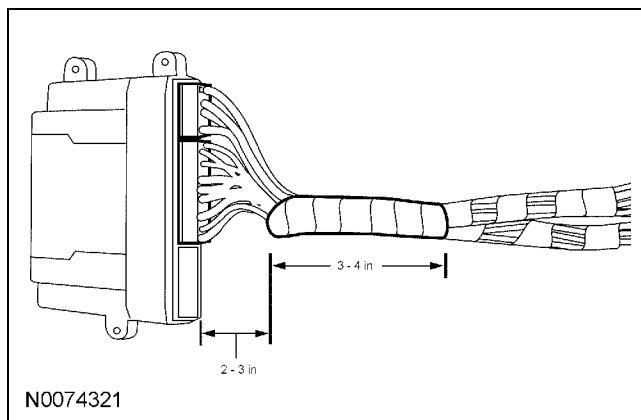

### Vehicle Preparation

9. Remove the LH instrument panel side finish panel.
- 1 Pull straight outward to release the retaining clips.

10. **NOTICE:** When removing scuff plate trim panels with Lincoln ambient lighting, care must be taken not to damage the aluminum insert.

Remove the scuff plate trim panel.

- 1 Using a flat trim tool, lift upward on the scuff plate trim panel to release the retainer clips.
  - 2 If equipped, disconnect the ambient light electrical connector.
11. Remove the steering column opening trim panel in the following sequence.
- 1 Remove the 2 screws.
  - 2 Pull the panel toward the rear of the vehicle releasing the retaining clips.
12. Remove the steering column shroud.
- 1 Remove the 3 screws and separate the lower from the upper steering column shroud.
  - 2 Disconnect the steering column control switch electrical connector and remove the steering column shrouds.
13. Remove the glove compartment.
14. Remove the 3 RH lower instrument panel insulator screws and remove the insulator.
15. Remove the LH and RH floor console lower trim panels.

### Antenna Mounting

**NOTE:** For good range of operation, the antenna must be installed correctly.

**NOTE:** Keep these points in mind when selecting a location and mounting the antenna.

- Do not mount the antenna behind or on any metal film or window tinting on the windshield.
- Do not mount the antenna so that one of the antenna elements touches or crosses any vehicle wiring and/or metal.
- On vehicles without metal film in the windshield around the rear view mirror, mount the antenna between the headliner and the rear view mirror.

**INSTALLATION (Continued)**

- On vehicles equipped with an electronic mirror, or on vehicles with metal film around the rearview mirror, mount the antenna approximately 3 inches below the mirror attachment point to the windshield and/or mirror electronics.

16. Choose a suitable mounting location following the guidelines above.

**Install The Antenna**

17. Clean the mounting surface using an alcohol base solution and a clean cloth.

18. **NOTE:** Do not touch the adhesive, reduced adhesion may result.

**NOTE:** Make sure that the long wire on the antenna is pointing towards the top of the windshield since this wire will be routed along the headliner.

**NOTE:** The wire will be attached to the control module later in this procedure.

Remove the protective backing from the adhesive on the antenna and firmly press the body of the antenna to the windshield.

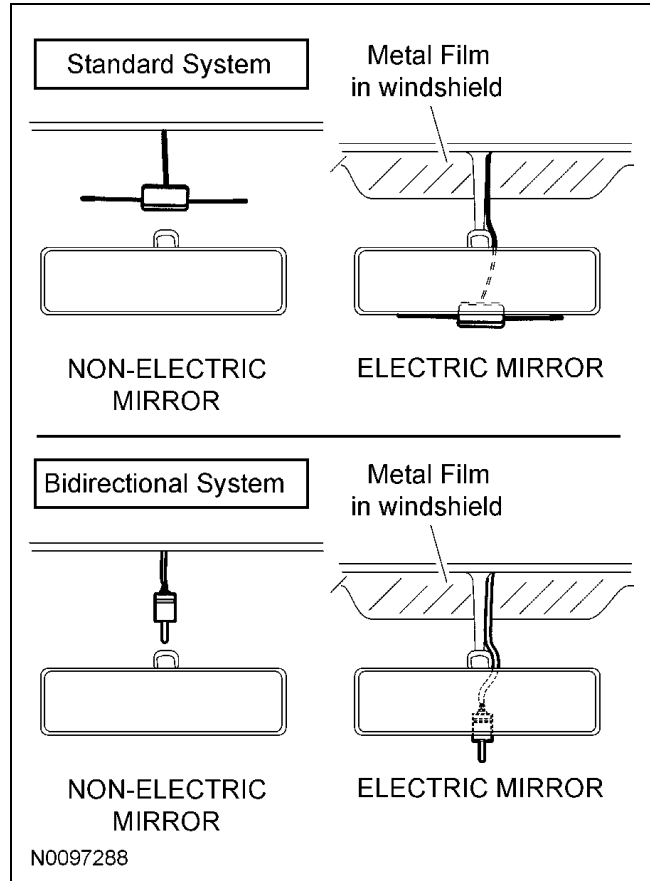

19. If necessary, position the A pillar trim slightly outward to provide access to route the antenna wire.

**NOTE:** Do not route the antenna wire over the top of the air bag.

20. Route the antenna cable along the headliner and down the A pillar towards the floor.

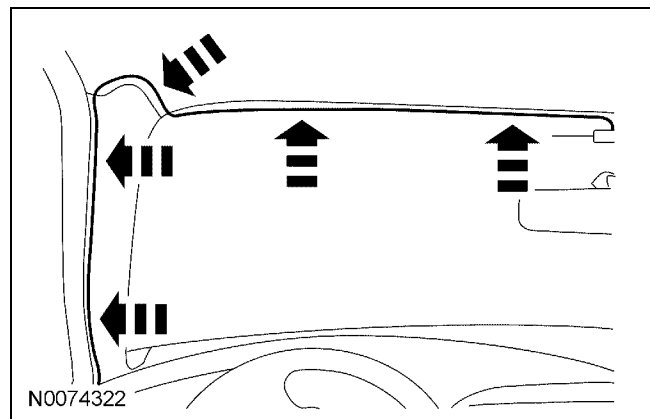

21. Reposition the A pillar trim panel.

**INSTALLATION (Continued)****Programming spare Intelligent Access (IA) Keys**

22. You must have two previously programmed Intelligent Access Keys inside the vehicle and the new unprogrammed Intelligent Access Keys readily accessible. If two previously programmed keys are not available, you must take your vehicle to your authorized dealer to have the spare key(s) programmed.

**NOTE:** A maximum of four Intelligent Access Keys can be programmed to your vehicle. If you would like to replace a previously programmed access key with a new access key, or if you already have four access keys programmed to your vehicle, you must take your vehicle and all access keys to your authorized dealer to be erased and reprogrammed.

**NOTE:** Ensure that the vehicle is off before beginning this procedure. Ensure that all doors are closed before beginning this procedure and that all doors remain closed throughout the procedure. Perform this procedure exactly as described below, and perform all steps within 30 seconds of starting the sequence. If any steps are performed out of sequence, stop and wait for at least one minute before starting again.

23. Please read and understand the entire procedure before you begin.
  - 1 Place the new unprogrammed Intelligent Access Key in the pocket inside the center console utility compartment.
  - 2 Press the driver or passenger power door unlock control three times.
  - 3 Press and release the brake pedal one time.
  - 4 Press the driver or passenger power door lock control three times.
  - 5 Press and release the brake pedal one time. The indicator on the Start/Stop button should begin to rapidly flash, indicating that programming mode has been entered and two programmed Intelligent Access Keys have been detected in the vehicle.
  - 6 Within one minute, press the start/stop button. A message will be displayed on the message center indicating that the new Intelligent Access Key was programmed. If four Intelligent Access Keys have already been programmed to your vehicle, you cannot program anymore and the message MAX # OF KEYS LEARNED will be displayed on the message center.
  - 7 Remove Intelligent Access Key from utility compartment pocket and press the unlock or lock control on the newly programmed Intelligent Access Keys to exit programming mode.
  - 8 Verify that the remote entry functions operate (lock, unlock) and that the vehicle starts with new Intelligent Access Key.
24. If the Intelligent Access Key has been successfully programmed, it can be used to activate the Intelligent Access with Push Button Start feature and can be used to start your vehicle.

**Install The Programmed IA Key In The PEPS Interface Module**

25. Remove the back cover from the PEPS Interface Module.
26. Remove the circuit board from the PEPS interface Module.

## INSTALLATION (Continued)

27. Open the programmed IA Key and remove the battery.

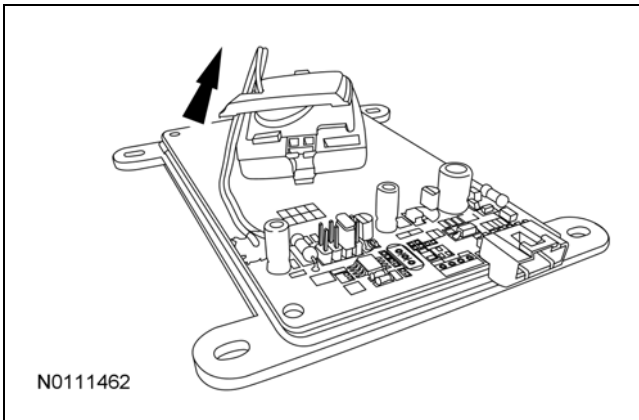

28. Install the slug attached to the circuit board, into the IA Key.
- Use the supplied key back to reassemble the key.
  - Loop the wire through the tab in the key back to make sure there is slack in the wire.
29. Using the foam insert to prevent rattling, secure the IA Key to the circuit board.
30. Reassemble the PEPS Interface Module.
- 1 Install the circuit board in to the module.
  - 2 Install the back cover to the PEPS Interface Module.
    - Install the 4 screws.

### Install The PEPS Interface Module

31. Mount the PEPS Interface Module in the front of the center console, under the dash.
32. **NOTICE: Do not attach the harness to the steering column.**  
Route the harness and connector the to module mounting location.

### Install the Remote Start Control Module and Harness Assembly

33. Place the remote start module and harness assembly on the floor of the vehicle.

### Identify Circuit Wires For Connections

**NOTE:** For vehicle specific wiring diagram(s) click [here](#).

**NOTE:** For proper wire splicing techniques click [here](#).

34. Connect the Black ground wire from the remote start module harness to the chassis ground point at the driver kick panel.

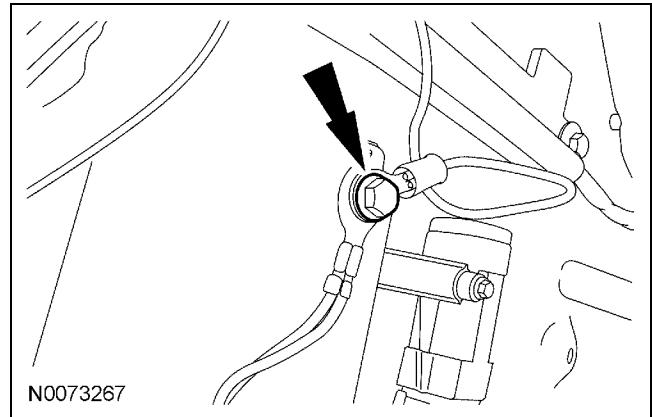

35. **NOTE:** A DVOM connected to the correct wire will show 12V, then show 0V when the horn button is held.

A logic probe will show power on the correct wire, then show ground when the horn button is held.

Identify the Blue/White horn circuit wire in the steering column harness.

36. Connect the Brown/Black wire from the remote start module harness to the Blue/White horn circuit wire in the steering column harness.

37. **NOTE:** A DVOM connected to the correct wire will show 0V, then show 12V when depressing the brake pedal.

A logic probe will show ground on the correct wire, then show power when depressing the brake pedal.

Identify the Violet/White brake input circuit wire at the Brake Pedal Switch.

38. Connect the Brown wire from the remote start module harness to the Violet/White brake input circuit wire at the Brake Pedal Switch.

**INSTALLATION (Continued)**

39. **NOTE:** A DVOM connected to the correct wire will show 12V, then show 0V when the start button is pressed.  
A logic probe will show power on the correct wire, then show ground when the start button is pressed.  
Identify the Yellow/Orange push button start circuit wire at the Start/Stop Switch.
40. Connect the Violet wire from the remote start module harness to the Yellow/Orange push button start circuit wire at the Start/Stop Switch.
41. **NOTE:** A DVOM connected to the correct wire will show 12V, then show 0V when the door lock switch is pressed.  
A logic probe will show power on the correct wire, then show ground when the door lock switch is pressed.  
**NOTE:** The Remote Function Actuator (RFA) Module is located behind the glove box opening.  
C2153E is the Brown connector.  
Identify the Blue/Green power door lock circuit wire at the Remote Function Actuator (RFA) Module C2153E Pin 16.
42. Connect the Blue wire from the remote start module harness to the Blue/Green wire at the RFA Module C2153E Pin 16.
43. **NOTE:** A DVOM connected to the correct wire will show 0V, then show open when the LF door is open.  
A logic probe will show power on the correct wire, then show ground when the LF door is open.  
**NOTE:** The Remote Function Actuator (RFA) Module is located behind the glove box opening.  
C2153E is the Brown connector.  
Identify the Green/Violet LF door ajar circuit wire at the RFA Module C2153E Pin 19.
44. Connect one of the Green/Violet wires from the remote start module harness to the Green/Violet LF door ajar circuit wire at the RFA Module C2153E Pin 19.
45. **NOTE:** A DVOM connected to the correct wire will show 0V, then show open when the LR door is open.  
A logic probe will show power on the correct wire, then show ground when the LR door is open.  
**NOTE:** The Remote Function Actuator (RFA) Module is located behind the glove box opening.  
C2153E is the Brown connector.  
Identify the Green LR door ajar circuit wire at the RFA Module C2153E Pin 21.
46. Connect one of the Green/Violet wires from the remote start module harness to the Green LR door ajar circuit wire at the RFA Module C2153E Pin 21.
47. **NOTE:** A DVOM connected to the correct wire will show 0V, then show open when the RF door is open.  
A logic probe will show power on the correct wire, then show ground when the RF door is open.  
**NOTE:** The Remote Function Actuator (RFA) Module is located behind the glove box opening.  
C2153E is the Brown connector.  
Identify the White RF door ajar circuit wire at the RFA Module C2153E Pin 18.
48. Connect one of the Green/Violet wires from the remote start module harness to the White RF door ajar circuit wire at the RFA Module C2153E Pin 18.
49. **NOTE:** A DVOM connected to the correct wire will show 0V, then show open when the RR door is open.  
A logic probe will show power on the correct wire, then show ground when the RR door is open.  
**NOTE:** The Remote Function Actuator (RFA) Module is located behind the glove box opening.  
C2153E is the Brown connector.  
Identify the Yellow RR door ajar circuit wire at the RFA Module C2153E Pin 20.

**INSTALLATION (Continued)**

50. Connect one of the Green/Violet wires from the remote start module harness to the Yellow RR door ajar circuit wire at the RFA Module C2153E Pin 20.

51. **NOTE:** A DVOM connected to the correct wire will show 0V, then show open when the liftgate is open.

A logic probe will show power on the correct wire, then show ground when the liftgate is open.

**NOTE:** The Remote Function Actuator (RFA) Module is located behind the glove box opening.

C2153E is the Brown connector.

Identify the Gray/Orange liftgate ajar circuit wire at the RFA Module C2153E Pin 22.

52. Connect one of the Green/Violet wires from the remote start module harness to the Gray/Orange liftgate ajar circuit wire at the RFA Module C2153E Pin 22.

53. **NOTE:** A DVOM connected to the correct wire will show 12V, when the headlight switch is ON, then show 0V when the headlight switch is OFF.

A logic probe will show power on the correct wire when the headlight switch is ON, then show ground when the headlight switch is OFF.

Identify the Violet/White parking light circuit wire at the SJB C2280E Pin 6.

54. Connect the White wire from the remote start module harness to the Violet/White parking light circuit wire at the SJB C2280E Pin 6.

55. **NOTE:** A DVOM connected to the correct wire will show 12V in RUN/ACC.

A logic probe will show power in RUN/ACC on the correct wire.

Identify the Violet/Green ignition circuit wire at the SJB C2280A Connector Pin 3.

56. Connect the Pink wire from the remote start module harness to the Violet/Green ignition circuit wire at the SJB C2280A Connector Pin 3.

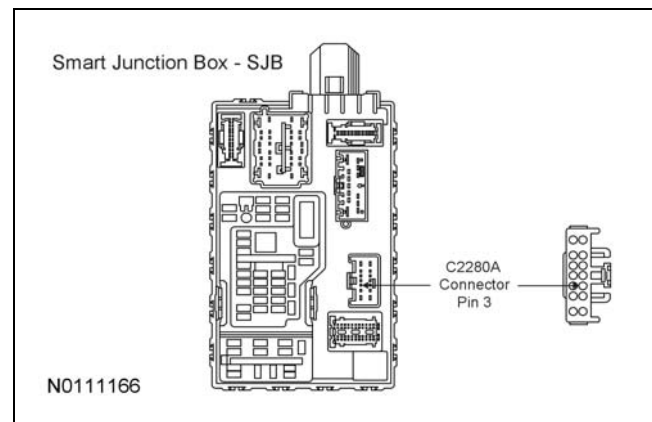
**Install The Hood Safety Switch**

57. **NOTE:** Route the hood safety switch wire carefully avoiding any moving parts or components that can produce excessive heat.

**NOTE:** Using a piece of convolute adds in the appearance of the installation.

**NOTE:** The switch should be positioned about 30 degrees below parallel to the ground to accommodate for parking on inclines.

Failure to position the switch properly could result in one of the following:

- False alarm trips
- Non-Remote Start events
- Inadvertent shutdown during Remote Start

Locate an easy to access area near the driver side hood hinge and install the hood safety switch using the supplied metal screws.

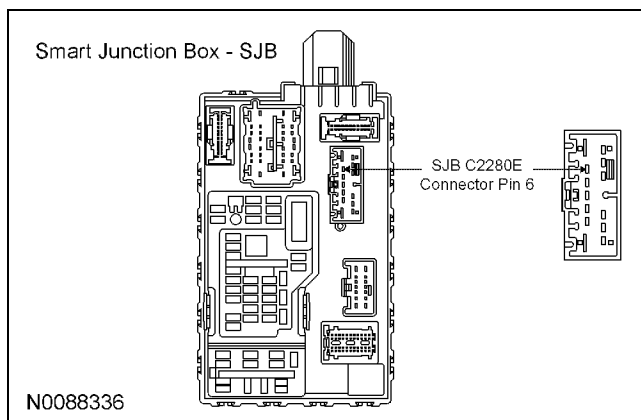

**INSTALLATION (Continued)**

- 58. Apply rustproofing compound (PM-13-A) to the drilled hole and torque the screw to 1.00 Nm (10 lb-in).

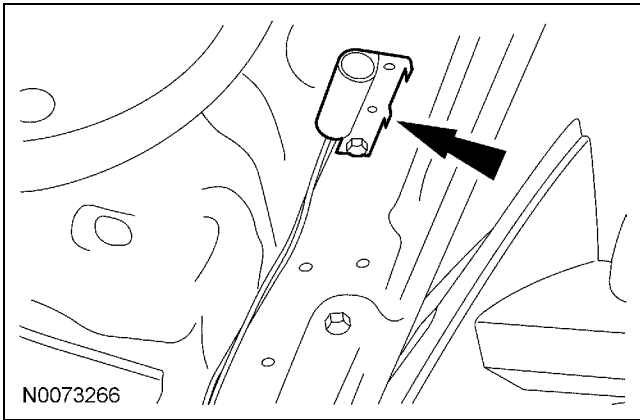

- 59. Connect hood switch ground wire to a suitable location on the bulkhead.

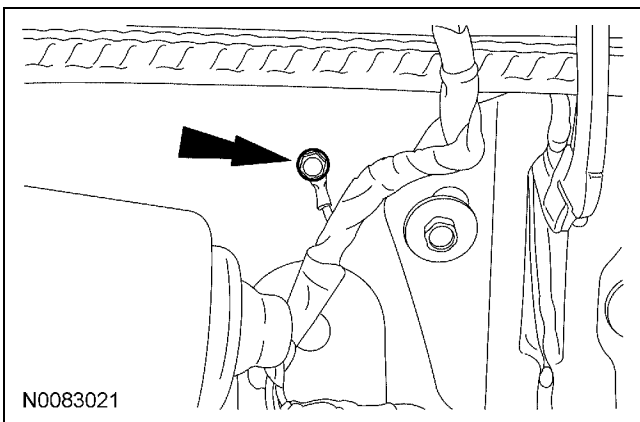

- 60. **NOTE:** Place the label on the radiator fan shroud or similar area. Install the underhood warning label.

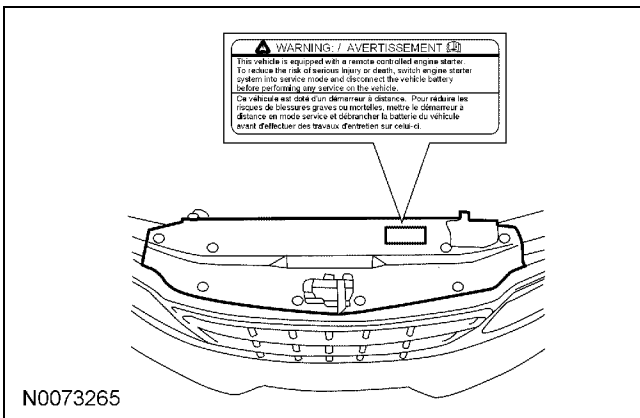

- 61. Route the Gray hood safety switch wire through the bulkhead into the engine compartment and attach to the hood safety switch.
- 62. Connect the antenna to the RMST control module.

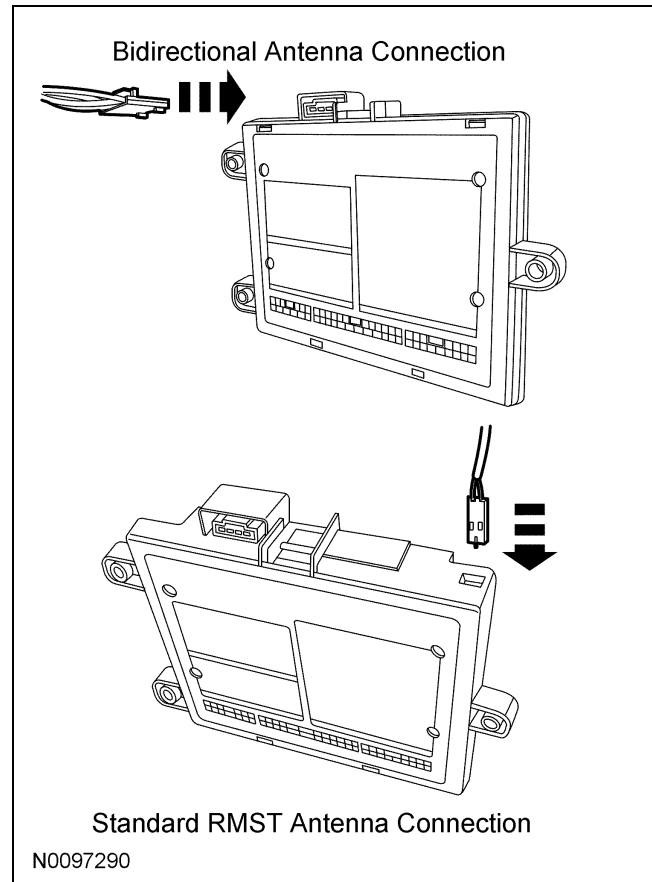

- 63. Connect the PEPS interface module to the RMST control module.

**Power Connection**

- 64. **NOTE:** A DVOM connected to the correct wire will show 12V at all times. A logic probe will show power at all times on the correct wire. Identify the Green/Red B+ circuit wire at the SJB C2280A Pin 10.
- 65. Connect the Red wire from the remote start module harness to the Green/Red B+ circuit wire at the SJB C2280A Pin 10.

## INSTALLATION (Continued)

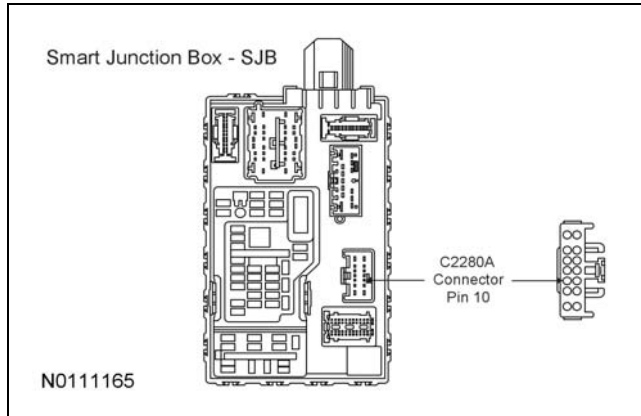

### Program The RMST System

66. [Refer to the RMST programming section for this vehicle click here.](#)

### Secure RMST Harness and Control Module

67. Use the supplied tie wraps to secure the RMST harness wires.

68. **NOTE:** Do not mount the control module in the knee bolster area.

Secure the control module at three points to the vehicle.

Use the supplied long tie wraps to mount the RMST control module to the underdash wiring harness.

### Install Trim

69. Install the LH and RH floor console front side trim panels.
70. Install the RH lower instrument panel insulator.
- Install the 3 screws.
71. Install the glove compartment.
72. Install the upper and lower steering column shrouds.
- Connect the steering column control switch electrical connector.
  - Install the 3 screws to the lower steering column shroud.
73. Install the steering column opening trim panel.
- 1 Install the 2 screws.
74. **NOTICE: To avoid damage to the scuff plate trim panel, remove any retaining clips from the body and attach them to the scuff plate trim panel before installing.**
- Install the scuff plate trim panel.
- If equipped, disconnect the ambient scuff plate trim panel electrical connector.
75. Install the LH instrument panel side finish panel.



## GENERAL PROCEDURES

### Programming

#### Functional Test

**NOTE:** If during any of the steps of the functional test, the remote start system or vehicle doesn't react or perform accordingly, please refer to the remote start troubleshooting guide.

**NOTE:** For remote start troubleshooting guide click [here](#).

1. Make sure all doors are closed but hood is open and windows are down (doors will be locking).
  2. Verify the module receives the start request from the remote control key fob.
    - For Standard Remote Start, press and hold the start button on the remote control key fob for 2-3 seconds - Horn should honk once indicating receipt of the start request.
    - For Bidirectional Remote Start, press the start button on the remote control key fob twice within 3 seconds - Horn should honk once indicating receipt of the start request.
  3. The remote start systems should turn on the ignition, but then honk the horn twice and shut down indicating the hood is open.
  4. Close the hood, and open a door.
  5. Attempt to re-start the vehicle again using the key fob.
  6. The remote start systems should turn on the ignition, but then honk the horn three times and shut down indicating a door is open.
  7. Close the door.
  8. Attempt to re-start the vehicle again using the key fob.
9. Once the vehicle starts, verify that all heat and A/C functions operate normally and that the doors have locked.
  10. On vehicles equipped with power window interrupt, Attempt to close windows to check power window interrupt function.
  11. Once all systems have been checked, press the brake pedal - the remote start systems should shut down.

#### Troubleshooting

12. **NOTE:** When attempting to remote start your vehicle, the system has several safety checks that it performs. If any of these inputs are present that should not be, the system will respond back to you with several horn "chirps" to help you identify which input is present. These "chirps" will occur after initiating a start sequence with the transmitter, the system will turn on the ignition, but then respond back with several horn "chirps" and abort the starting process.

**Example:** Depress the remote start fob button for 3 seconds and then release. The vehicle horn will "chirp" one time to indicate that RMST signal was received. If the vehicle doesn't start and the horn "chirps" 3 times, there is a fault - "Vehicle Door is Open"

CHIRPS	PROBLEM
1 Chirp	Intelligent Access (IA) key not programmed correctly, or the PEPS Interface Module is damaged.
2 Chirps	BRAKE is being pressed, or the HOOD is open.
3 Chirps	One of the vehicles DOORS are open.
4 Chirps	TACH not programmed.
6 Chirps	The remote start system is in SERVICE/VALET mode.

**RMSTMODULE WIRE HARNESS**

**DRIVER'S KICK PANEL HARNESS**

	Color	Function
A-5	BLACK	Ground
A-11	PINK	Ignition Input/Output
A-1	WHITE	Parking Light Output
A-4	RED	Battery

**MAKE THIS CONNECTION FIRST!**



CHASSIS GROUND POINT  
IN DRIVER'S KICK PANEL

SMART  
JUNCTION  
BOX

Ignition (VIOLET/GREEN)



SJBC2280A  
PIN3

Parking Lights (VIOLET/WHITE)



SJBC2280E  
PIN6

Battery (GREEN/RED)



SJBC2280A  
PIN10

**MAKE THIS CONNECTION LAST!**

**STEERING COLUMN HARNESS**

	Color	Function
A-21	BROWN/BLACK	Horn Relay Output

Horn (BLUE/WHITE)



STEERING  
COLUMN  
HARNESS

**BRAKE PEDAL HARNESS**

	Color	Function
A-7	BROWN	Brake Input

Brake (VIOLET/WHITE)



BRAKE  
PEDAL  
SWITCH

**START/ STOP SWITCH HARNESS**

	Color	Function
A-13	VIOLET	Starter Output

Push Button Start (YELLOW/ORANGE)



START/STOP  
SWITCH  
HARNESS

**UNDER HOOD HARNESS**

	Color	Function
A-19	GRAY	Hood Open Switch Input

Vehicle  
Interior

Engine  
Compartment

Hood Tilt Switch

Chassis  
Ground



Do Not Ground to Hood

RMST MODULE WIRE HARNESS

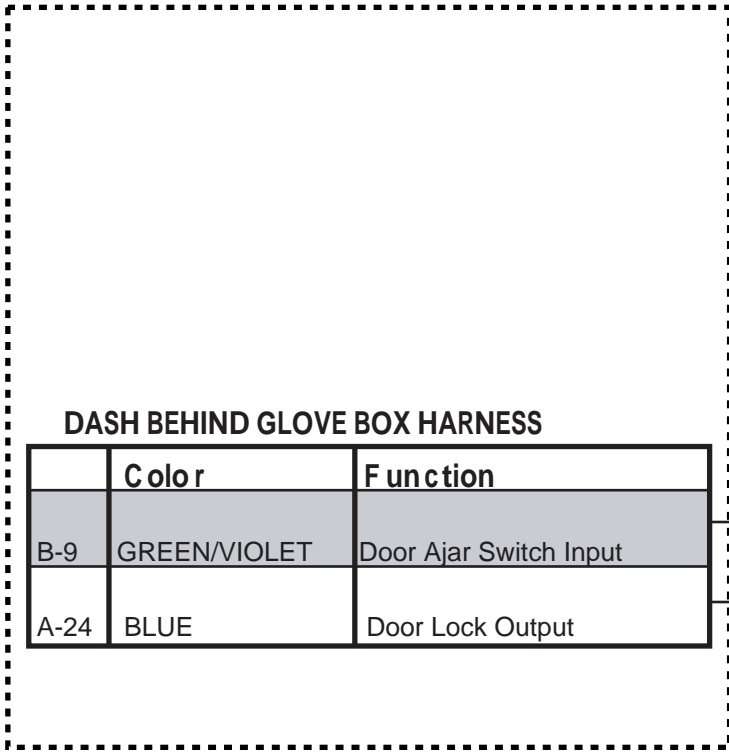

DASH BEHIND GLOVE BOX HARNESS

	Color	Function
B-9	GREEN/VIOLET	Door Ajar Switch Input
A-24	BLUE	Door Lock Output

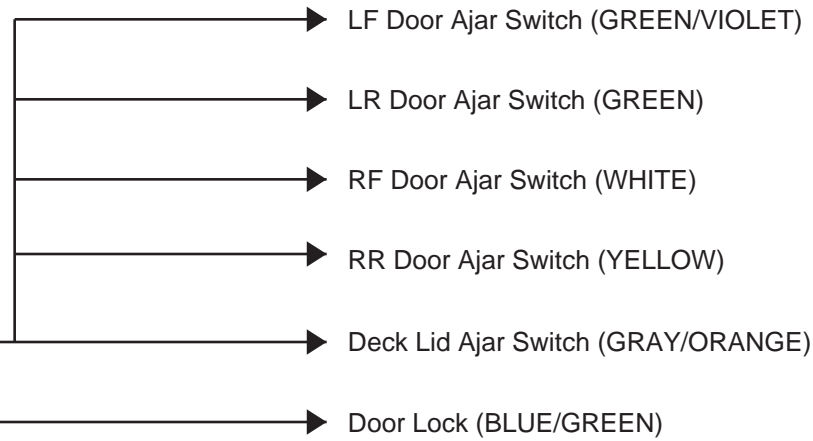

REMOTE FUNCTION ACTUATOR (RFA) MODULE

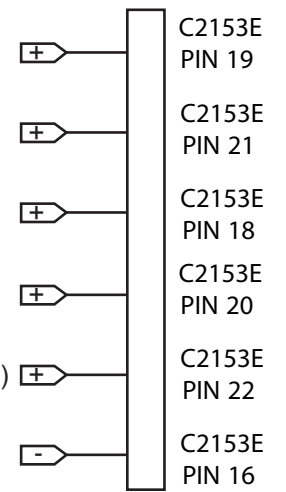

Smart Junction Box (SJB)

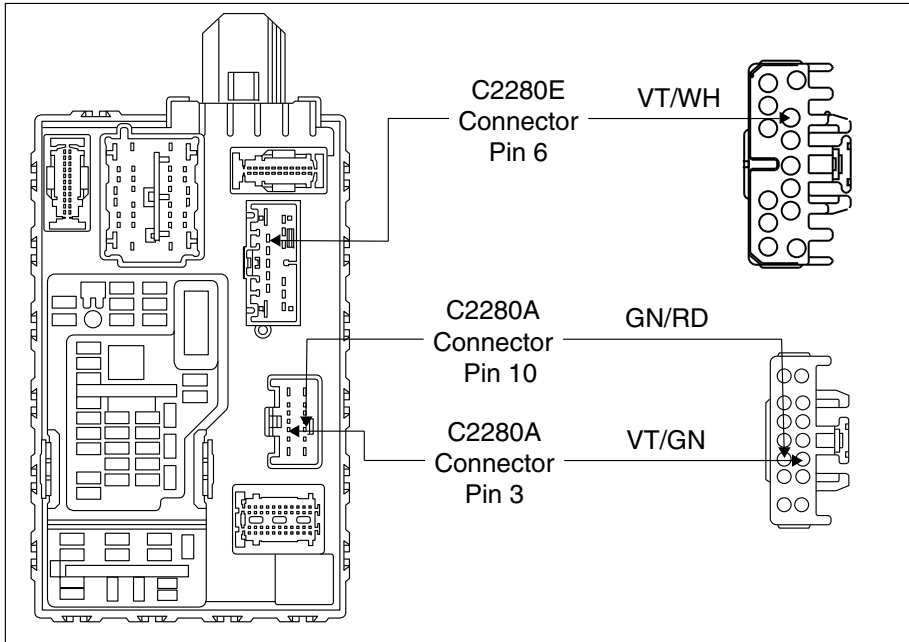

Remote function Actuator (RFA)

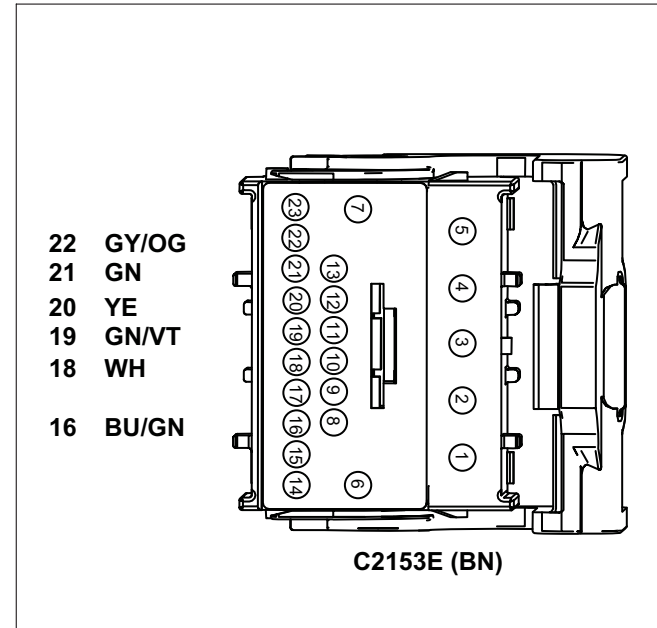

[Manual Table of Contents](#)

# REMOTE START SYSTEM INSTALLATION - PUSH-BUTTON START EQUIPPED VEHICLES

## CONTENTS

### INSTALLATION

[Remote Start](#)

[Programming - Spare Intelligent Access \(IA\)Keys](#)

### GENERAL PROCEDURES

[Proper Splicing Techniques](#)

[Functional Test](#)

[Troubleshooting](#)

### WIRING DIAGRAMS

[Vehicle Specific Wiring Diagrams](#)

# INSTALLATION

## Remote Start — Taurus

### Remote Start System RMST Components

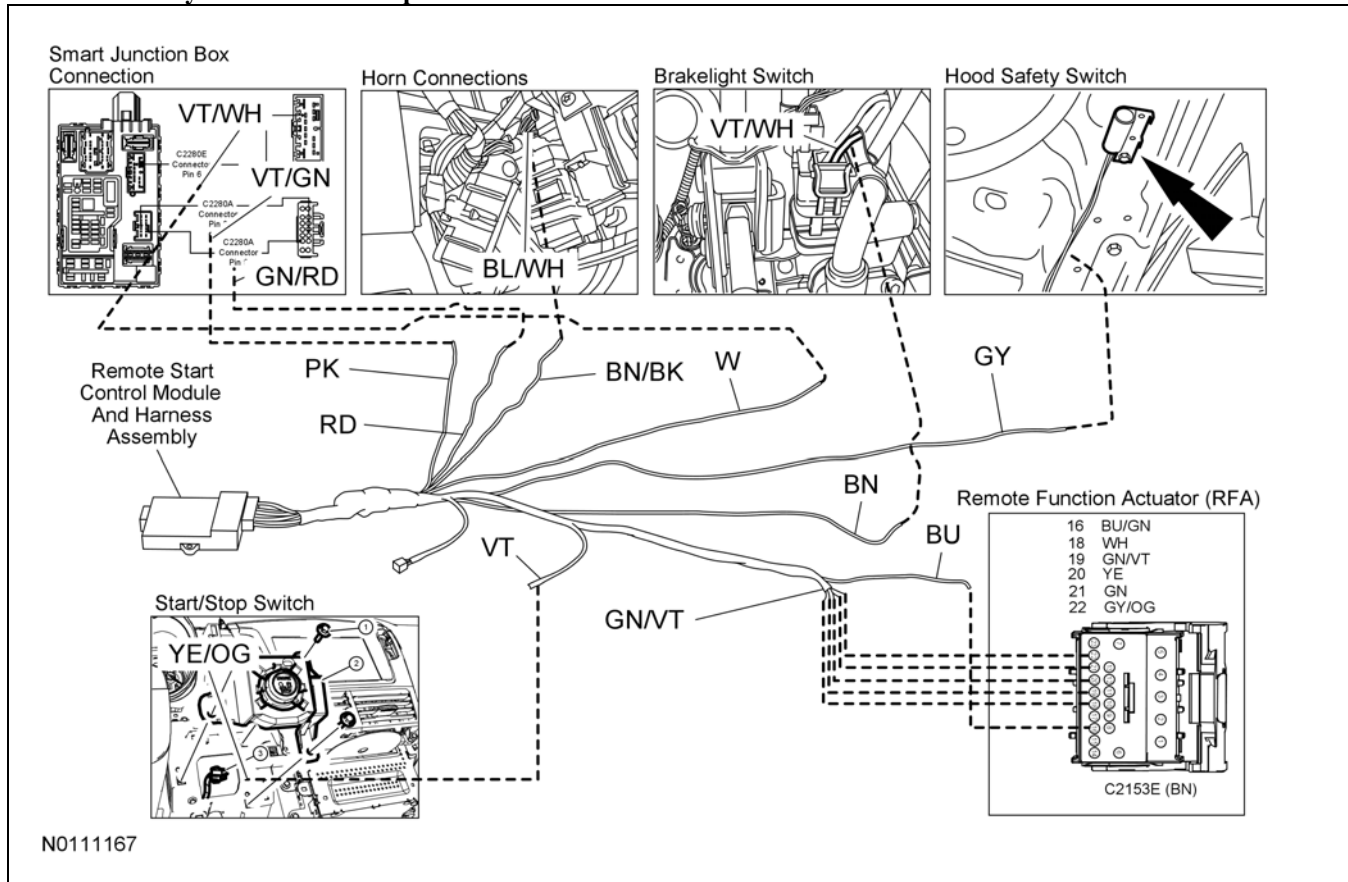

### Taurus

**NOTICE:** Remote start systems are only applicable to vehicles with automatic transmissions.

**NOTE:** Both original keys are required for all remote start systems.

1. Verify correct kit number.

**INSTALLATION (Continued)**

**Review Remote Start Installation Kit Contents**

**NOTE:** Kits are vehicle specific and are not interchangeable.

2. Review the RMST kit contents.

**Remote Start System Standard Kit (RMST) Type - "A"**

QUANTITY	DESCRIPTION
1	TYPE - "A" MODULE ASSEMBLY
1	RMST SOFTWARE CARTRIDGE ASSEMBLY
2	1 BUTTON POWERCODE TRANSMITTER
1	TYPE - "A" CUSTOM WIRING HARNESS
1	ANTENNA
1	HOOD SAFETY SWITCH ASSEMBLY
1	INSTALLATION PARTS BAG
1	FUSE PARTS BAG
1	OPERATORS INSTRUCTIONS
1	OPERATORS QUICK REFERENCE WALLET CARD
1	UNDERHOOD WARNING LABEL
1	PEPS INTERFACE MODULE

3. Review the RMST bidirectional kit contents.

**Remote Start System Bidirectional Kit (RMST) Type - "A"**

QUANTITY	DESCRIPTION
1	TYPE - "A" MODULE ASSEMBLY
1	RMST SOFTWARE CARTRIDGE ASSEMBLY

**Remote Start System Bidirectional Kit (RMST) Type - "A" (Continued)**

QUANTITY	DESCRIPTION
1	2 BUTTON POWERCODE TRANSMITTER
1	TYPE - "A" CUSTOM WIRING HARNESS
1	ANTENNA
1	ANTENNA HARNESS
1	HOOD SAFETY SWITCH ASSEMBLY
1	INSTALLATION PARTS BAG
1	FUSE PARTS BAG
1	OPERATORS INSTRUCTIONS
1	OPERATORS QUICK REFERENCE WALLET CARD
1	UNDERHOOD WARNING LABEL
1	PEPS INTERFACE MODULE

**Module Preparation**

- Place the supplied fuses into the power distribution block on the remote start control module.
  - Move the polarity jumpers to their proper locations on the control module, see illustration.

INSTALLATION (Continued)

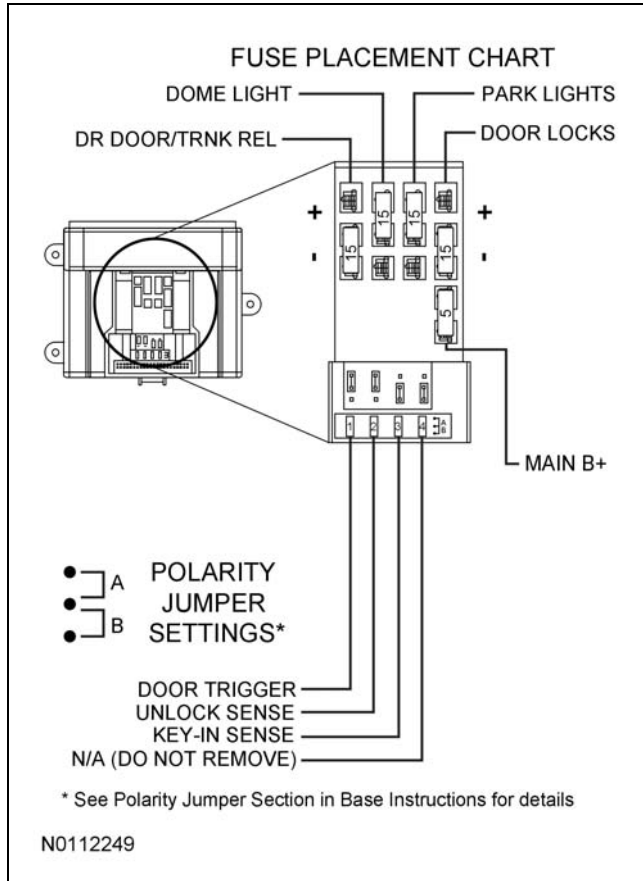

- Place the software cartridge onto the RMST control module.

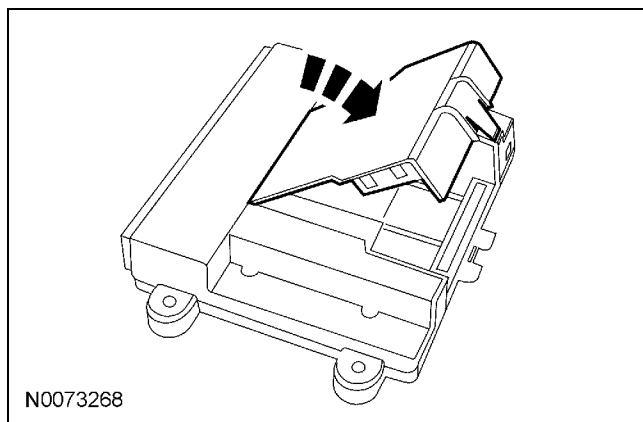

- Plug the wiring harness(es) into the module.
  - A - Harness: 24-way, used on all systems.
  - B - Harness: 10-way, used on all systems with RMST.

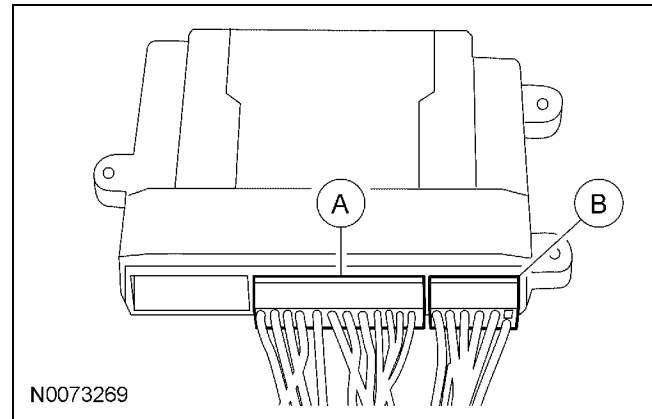

- NOTE:** Do not cut the override programming button off of the harness, it is used for all installations.

**NOTE:** For vehicle specific wiring diagram(s) click [here](#).

Referring to the vehicle specific wiring section for the system being installed, gather all individual wires that will be routed to the same areas of the vehicle into groups. Cover each wire group with electrical tape for approximately 18". Depending on the vehicle, there will be 2 to 5 different wire groups.

Trim the unused wires approximately 6 - 8" from the module.

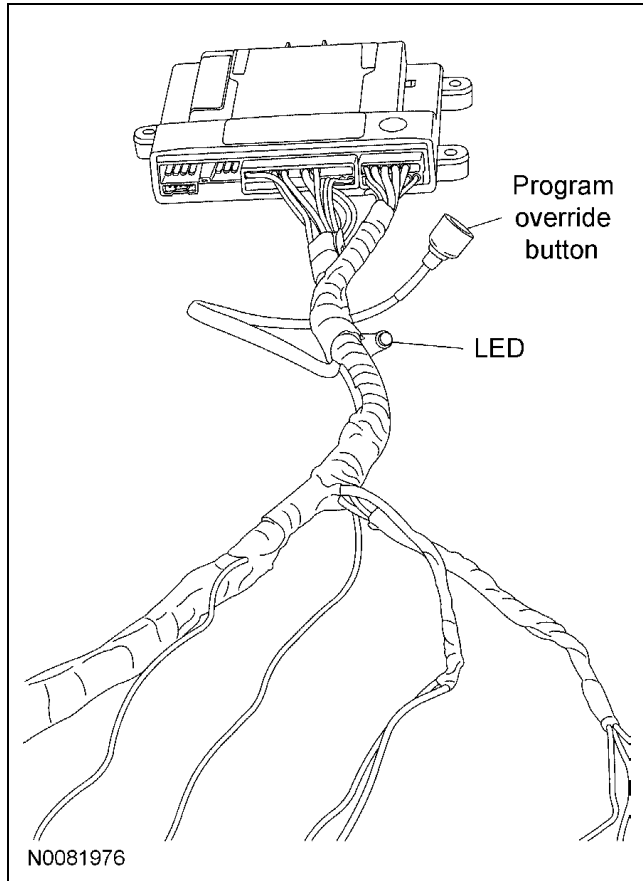

**INSTALLATION (Continued)**

8. Tape the harness sections together, making sure to cover all of the unused wires.

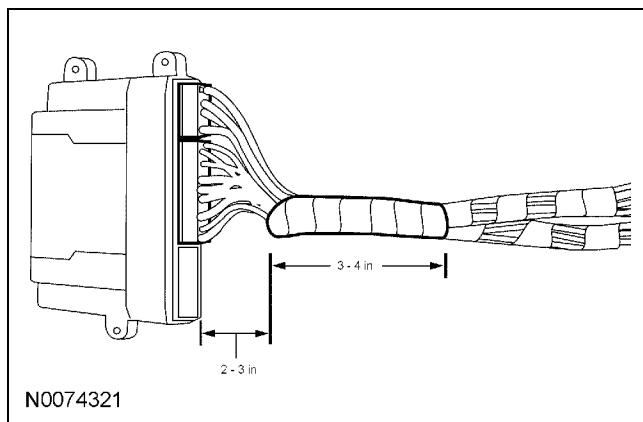
**Vehicle Preparation**

9. Remove the 2 lower instrument panel steering column cover screws and the cover.
10. Remove the LH instrument panel side finish panel.

11. Remove the 3 screws and the upper and lower steering column shrouds.
12. Remove the left hand scuff plate and cowl trim panel.
13. Remove the floor console LH finish moulding, and disconnect the Start/ Stop Switch.
14. Remove the glove compartment.
15. Remove the RH lower instrument panel insulator.
16. Remove the LH and RH floor console lower trim panels.

**Antenna Mounting**

**NOTE:** For good range of operation, the antenna must be installed correctly.

**NOTE:** Keep these points in mind when selecting a location and mounting the antenna.

- Do not mount the antenna behind or on any metal film or window tinting on the windshield.
- Do not mount the antenna so that one of the antenna elements touches or crosses any vehicle wiring and/or metal.
- On vehicles without metal film in the windshield around the rear view mirror, mount the antenna between the headliner and the rear view mirror.
- On vehicles equipped with an electronic mirror, or on vehicles with metal film around the rearview mirror, mount the antenna approximately 3 inches below the mirror attachment point to the windshield and/or mirror electronics.

17. Choose a suitable mounting location following the guidelines above.

**Install The Antenna**

18. Clean the mounting surface using an alcohol base solution and a clean cloth.

**INSTALLATION (Continued)**

19. **NOTE:** Do not touch the adhesive, reduced adhesion may result.

**NOTE:** Make sure that the long wire on the antenna is pointing towards the top of the windshield since this wire will be routed along the headliner.

**NOTE:** The wire will be attached to the control module later in this procedure.

Remove the protective backing from the adhesive on the antenna and firmly press the body of the antenna to the windshield.

20. If necessary, position the A pillar trim slightly outward to provide access to route the antenna wire.

**NOTE:** Do not route the antenna wire over the top of the air bag.

21. Route the antenna cable along the headliner and down the A pillar towards the floor.

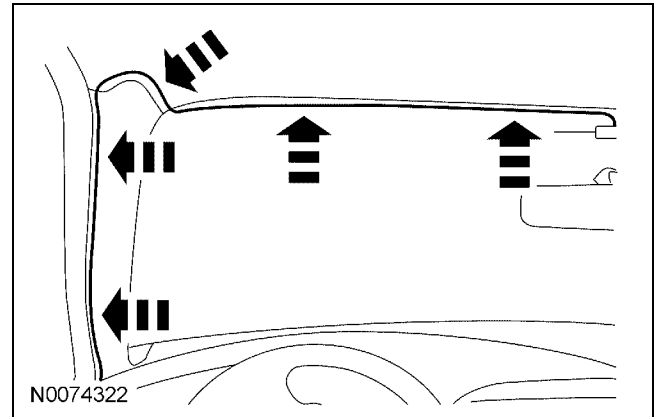
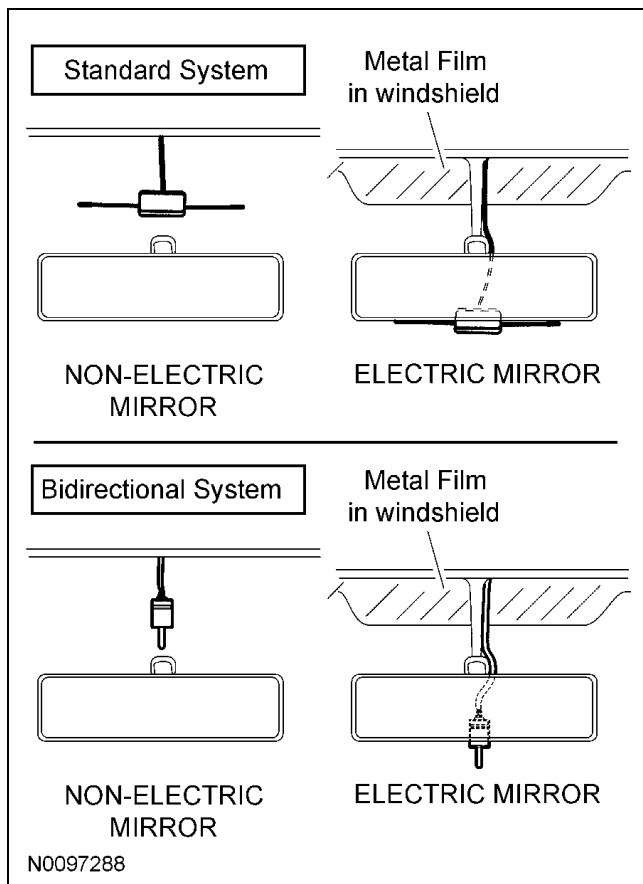

22. Reposition the A pillar trim panel.

**Programming spare Intelligent Access (IA) Keys**

23. You must have two previously programmed Intelligent Access Keys inside the vehicle and the new unprogrammed Intelligent Access Keys readily accessible. If two previously programmed keys are not available, you must take your vehicle to your authorized dealer to have the spare key(s) programmed.

**INSTALLATION (Continued)**

**NOTE:** A maximum of four Intelligent Access Keys can be programmed to your vehicle. If you would like to replace a previously programmed access key with a new access key, or if you already have four access keys programmed to your vehicle, you must take your vehicle and all access keys to your authorized dealer to be erased and reprogrammed.

**NOTE:** Ensure that the vehicle is off before beginning this procedure. Ensure that all doors are closed before beginning this procedure and that all doors remain closed throughout the procedure. Perform this procedure exactly as described below, and perform all steps within 30 seconds of starting the sequence. If any steps are performed out of sequence, stop and wait for at least one minute before starting again.

24. Please read and understand the entire procedure before you begin.
  - 1 Place the new unprogrammed Intelligent Access Key in the pocket inside the center console utility compartment.
  - 2 Press the driver or passenger power door unlock control three times.
  - 3 Press and release the brake pedal one time.
  - 4 Press the driver or passenger power door lock control three times.
  - 5 Press and release the brake pedal one time. The indicator on the Start/Stop button should begin to rapidly flash, indicating that programming mode has been entered and two programmed Intelligent Access Keys have been detected in the vehicle.
  - 6 Within one minute, press the start/stop button. A message will be displayed on the message center indicating that the new Intelligent Access Key was programmed. If four Intelligent Access Keys have already been programmed to your vehicle, you cannot program anymore and the message MAX # OF KEYS LEARNED will be displayed on the message center.
  - 7 Remove Intelligent Access Key from utility compartment pocket and press the unlock or lock control on the newly programmed Intelligent Access Keys to exit programming mode.
  - 8 Verify that the remote entry functions operate (lock, unlock) and that the vehicle starts with new Intelligent Access Key.
25. If the Intelligent Access Key has been successfully programmed, it can be used to activate the Intelligent Access with Push Button Start feature and can be used to start your vehicle.

**Install The Programmed IA Key In The PEPS Interface Module**

26. Remove the back cover from the PEPS Interface Module.
27. Remove the circuit board from the PEPS interface Module.

**INSTALLATION (Continued)**

28. Open the programmed IA Key and remove the battery.

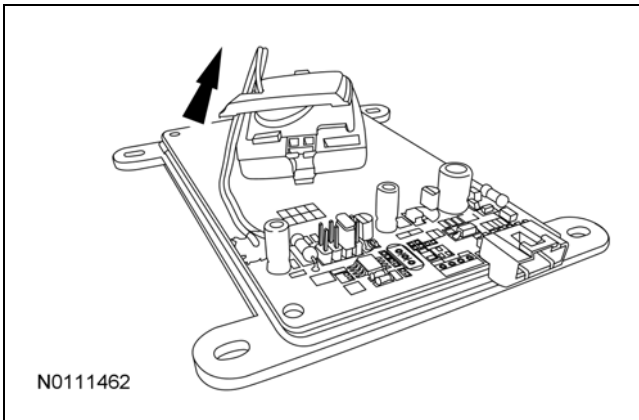

29. Install the slug attached to the circuit board, into the IA Key.
- Use the supplied key back to reassemble the key.
  - Loop the wire through the tab in the key back to make sure there is slack in the wire.
30. Using the foam insert to prevent rattling, secure the IA Key to the circuit board.
31. Reassemble the PEPS Interface Module.
- 1 Install the circuit board in to the module.
  - 2 Install the back cover to the PEPS Interface Module.
    - Install the 4 screws.

**Install The PEPS Interface Module**

32. Mount the PEPS Interface Module in the front of the center console, under the dash.
33. **NOTICE: Do not attach the harness to the steering column.**  
Route the harness and connector the to module mounting location.

**Install the Remote Start Control Module and Harness Assembly**

34. Place the remote start module and harness assembly on the floor of the vehicle.

**Identify Circuit Wires For Connections**

**NOTE:** For vehicle specific wiring diagram(s) click [here](#).

**NOTE:** For proper wire splicing techniques click [here](#).

35. Connect the Black ground wire from the remote start module harness to the chassis ground point at the driver kick panel.

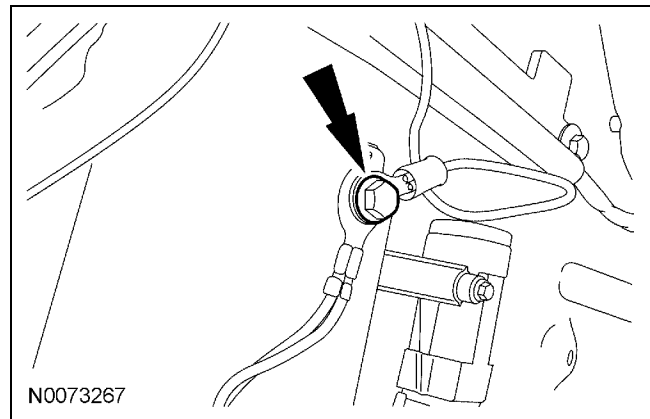

36. **NOTE:** A DVOM connected to the correct wire will show 12V, then show 0V when the horn button is held.

A logic probe will show power on the correct wire, then show ground when the horn button is held.

Identify the Blue/White horn circuit wire in the steering column harness.

37. Connect the Brown/Black wire from the remote start module harness to the Blue/White horn circuit wire in the steering column harness.

38. **NOTE:** A DVOM connected to the correct wire will show 0V, then show 12V when depressing the brake pedal.

A logic probe will show ground on the correct wire, then show power when depressing the brake pedal.

Identify the Violet/White brake input circuit wire at the Brake Pedal Switch.

39. Connect the Brown wire from the remote start module harness to the Violet/White brake input circuit wire at the Brake Pedal Switch.

**INSTALLATION (Continued)**

40. **NOTE:** A DVOM connected to the correct wire will show 12V, then show 0V when the start button is pressed.  
A logic probe will show power on the correct wire, then show ground when the start button is pressed.  
Identify the Yellow/Orange push button start circuit wire at the Start/Stop Switch.
41. Connect the Violet wire from the remote start module harness to the Yellow/Orange push button start circuit wire at the Start/Stop Switch.
42. **NOTE:** A DVOM connected to the correct wire will show 12V, then show 0V when the door lock switch is pressed.  
A logic probe will show power on the correct wire, then show ground when the door lock switch is pressed.  
**NOTE:** The Remote Function Actuator (RFA) Module is located behind the glove box opening.  
C2153E is the Brown connector.  
Identify the Blue/Green power door lock circuit wire at the Remote Function Actuator (RFA) Module C2153E Pin 16.
43. Connect the Blue wire from the remote start module harness to the Blue/Green wire at the RFA Module C2153E Pin 16.
44. **NOTE:** A DVOM connected to the correct wire will show 0V, then show open when the LF door is open.  
A logic probe will show power on the correct wire, then show ground when the LF door is open.  
**NOTE:** The Remote Function Actuator (RFA) Module is located behind the glove box opening.  
C2153E is the Brown connector.  
Identify the Green/Violet LF door ajar circuit wire at the RFA Module C2153E Pin 19.
45. Connect one of the Green/Violet wires from the remote start module harness to the Green/Violet LF door ajar circuit wire at the RFA Module C2153E Pin 19.
46. **NOTE:** A DVOM connected to the correct wire will show 0V, then show open when the LR door is open.  
A logic probe will show power on the correct wire, then show ground when the LR door is open.  
**NOTE:** The Remote Function Actuator (RFA) Module is located behind the glove box opening.  
C2153E is the Brown connector.  
Identify the Green LR door ajar circuit wire at the RFA Module C2153E Pin 21.
47. Connect one of the Green/Violet wires from the remote start module harness to the Green LR door ajar circuit wire at the RFA Module C2153E Pin 21.
48. **NOTE:** A DVOM connected to the correct wire will show 0V, then show open when the RF door is open.  
A logic probe will show power on the correct wire, then show ground when the RF door is open.  
**NOTE:** The Remote Function Actuator (RFA) Module is located behind the glove box opening.  
C2153E is the Brown connector.  
Identify the White RF door ajar circuit wire at the RFA Module C2153E Pin 18.
49. Connect one of the Green/Violet wires from the remote start module harness to the White RF door ajar circuit wire at the RFA Module C2153E Pin 18.
50. **NOTE:** A DVOM connected to the correct wire will show 0V, then show open when the RR door is open.  
A logic probe will show power on the correct wire, then show ground when the RR door is open.  
**NOTE:** The Remote Function Actuator (RFA) Module is located behind the glove box opening.  
C2153E is the Brown connector.  
Identify the Yellow RR door ajar circuit wire at the RFA Module C2153E Pin 20.

**INSTALLATION (Continued)**

51. Connect one of the Green/Violet wires from the remote start module harness to the Yellow RR door ajar circuit wire at the RFA Module C2153E Pin 20.

52. **NOTE:** A DVOM connected to the correct wire will show 0V, then show open when the liftgate is open.

A logic probe will show power on the correct wire, then show ground when the liftgate is open.

**NOTE:** The Remote Function Actuator (RFA) Module is located behind the glove box opening.

C2153E is the Brown connector.

Identify the Gray/Orange liftgate ajar circuit wire at the RFA Module C2153E Pin 22.

53. Connect one of the Green/Violet wires from the remote start module harness to the Gray/Orange liftgate ajar circuit wire at the RFA Module C2153E Pin 22.

54. **NOTE:** A DVOM connected to the correct wire will show 12V, when the headlight switch is ON, then show 0V when the headlight switch is OFF.

A logic probe will show power on the correct wire when the headlight switch is ON, then show ground when the headlight switch is OFF.

Identify the Violet/White parking light circuit wire at the SJB C2280E Pin 6.

55. Connect the White wire from the remote start module harness to the Violet/White parking light circuit wire at the SJB C2280E Pin 6.

56. **NOTE:** A DVOM connected to the correct wire will show 12V in RUN/ACC.

A logic probe will show power in RUN/ACC on the correct wire.

Identify the Violet/Green ignition circuit wire at the SJB C2280A Connector Pin 3.

57. Connect the Pink wire from the remote start module harness to the Violet/Green ignition circuit wire at the SJB C2280A Connector Pin 3.

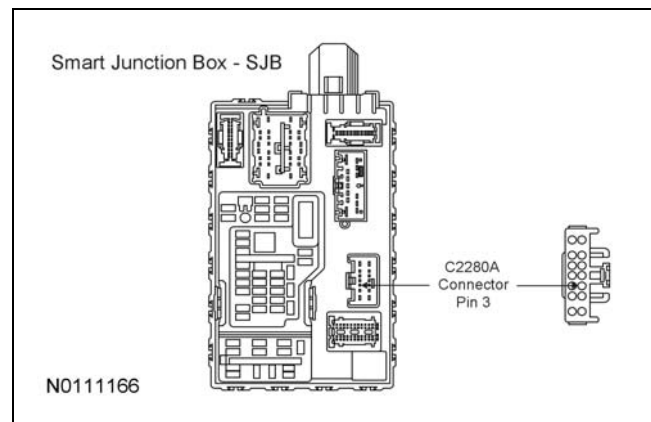
**Install The Hood Safety Switch**

58. **NOTE:** Route the hood safety switch wire carefully avoiding any moving parts or components that can produce excessive heat.

**NOTE:** Using a piece of convolute adds in the appearance of the installation.

**NOTE:** The switch should be positioned about 30 degrees below parallel to the ground to accommodate for parking on inclines.

Failure to position the switch properly could result in one of the following:

- False alarm trips
- Non-Remote Start events
- Inadvertent shutdown during Remote Start

Locate an easy to access area near the driver side hood hinge and install the hood safety switch using the supplied metal screws.

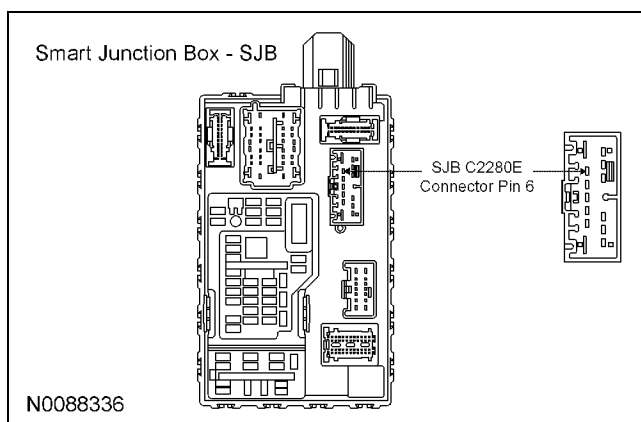

**INSTALLATION (Continued)**

- 59. Apply rustproofing compound (PM-13-A) to the drilled hole and torque the screw to 1.00 Nm (10 lb-in).

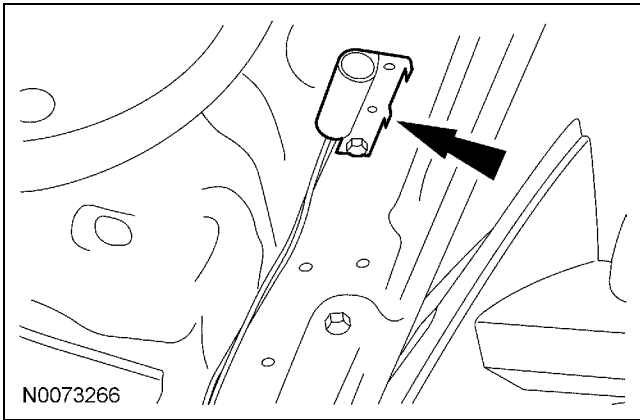

- 60. Connect hood switch ground wire to a suitable location on the bulkhead.

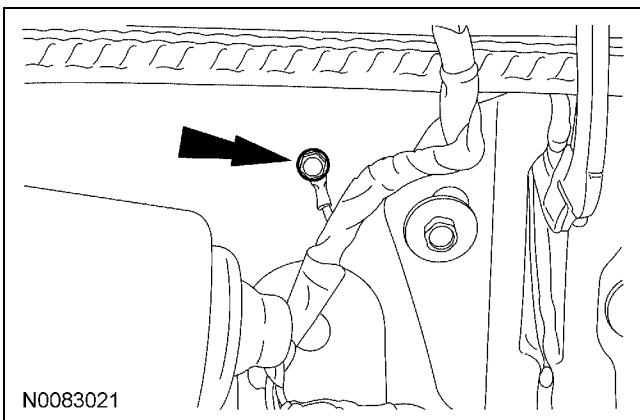

- 61. **NOTE:** Place the label on the radiator fan shroud or similar area. Install the underhood warning label.

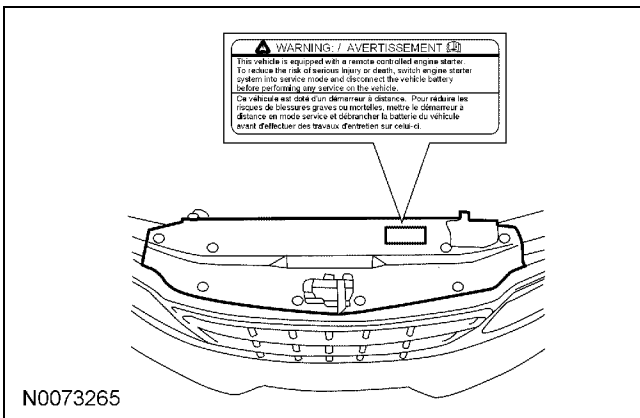

- 62. Route the Gray hood safety switch wire through the bulkhead into the engine compartment and attach to the hood safety switch.
- 63. Connect the antenna to the RMST control module.

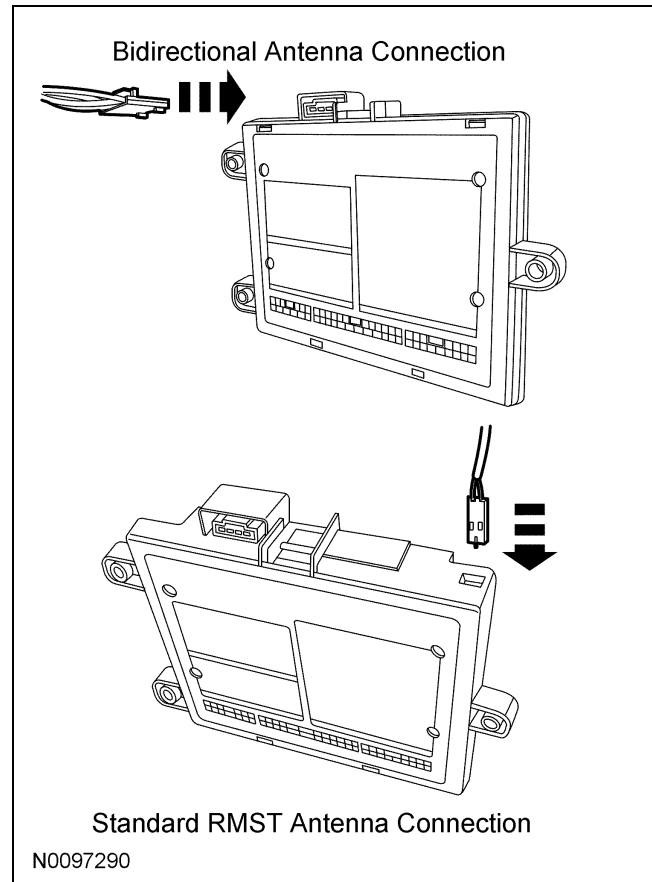

- 64. Connect the PEPS interface module to the RMST control module.

**Power Connection**

- 65. **NOTE:** A DVOM connected to the correct wire will show 12V at all times.

A logic probe will show power at all times on the correct wire.

Identify the Green/Red B+ circuit wire at the SJB C2280A Pin 10.

- 66. Connect the Red wire from the remote start module harness to the Green/Red B+ circuit wire at the SJB C2280A Pin 10.

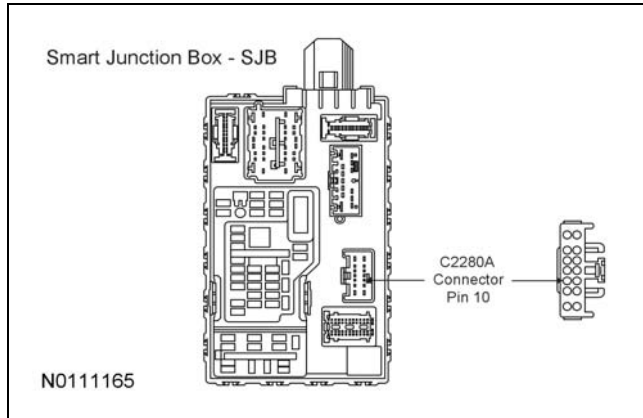
**INSTALLATION (Continued)****Program The RMST System**

67. [Refer to the RMST programming section for this vehicle click here.](#)

**Secure RMST Harness and Control Module**

68. Use the supplied tie wraps to secure the RMST harness wires.
69. **NOTE:** Do not mount the control module in the knee bolster area.

Secure the control module at three points to the vehicle.

Use the supplied long tie wraps to mount the RMST control module to the underdash wiring harness.

**Install Trim**

70. Install the LH and RH floor console lower trim panels.
71. Install the RH lower instrument panel insulator.
72. Install the glove compartment.
73. Connect the Start/ Stop Switch, and install the floor console LH finish moulding.
74. Install the upper and lower steering column shrouds.
  - Install the 3 screws to the lower steering column shroud.
75. Install the steering column opening trim panel.
  - Install the 2 screws.
76. Install the left hand scuff plate and cowl trim panel.
77. Install the LH instrument panel side finish panel.



## GENERAL PROCEDURES

### Programming

#### Functional Test

**NOTE:** If during any of the steps of the functional test, the remote start system or vehicle doesn't react or perform accordingly, please refer to the remote start troubleshooting guide.

**NOTE:** For remote start troubleshooting guide click [here](#).

1. Make sure all doors are closed but hood is open and windows are down (doors will be locking).
2. Verify the module receives the start request from the remote control key fob.
  - For Standard Remote Start, press and hold the start button on the remote control key fob for 2-3 seconds - Horn should honk once indicating receipt of the start request.
  - For Bidirectional Remote Start, press the start button on the remote control key fob twice within 3 seconds - Horn should honk once indicating receipt of the start request.
3. The remote start systems should turn on the ignition, but then honk the horn twice and shut down indicating the hood is open.
4. Close the hood, and open a door.
5. Attempt to re-start the vehicle again using the key fob.
6. The remote start systems should turn on the ignition, but then honk the horn three times and shut down indicating a door is open.
7. Close the door.
8. Attempt to re-start the vehicle again using the key fob.

9. Once the vehicle starts, verify that all heat and A/C functions operate normally and that the doors have locked.
10. On vehicles equipped with power window interrupt, Attempt to close windows to check power window interrupt function.
11. Once all systems have been checked, press the brake pedal - the remote start systems should shut down.

#### Troubleshooting

12. **NOTE:** When attempting to remote start your vehicle, the system has several safety checks that it performs. If any of these inputs are present that should not be, the system will respond back to you with several horn "chirps" to help you identify which input is present. These "chirps" will occur after initiating a start sequence with the transmitter, the system will turn on the ignition, but then respond back with several horn "chirps" and abort the starting process.

**Example:** Depress the remote start fob button for 3 seconds and then release. The vehicle horn will "chirp" one time to indicate that RMST signal was received. If the vehicle doesn't start and the horn "chirps" 3 times, there is a fault - "Vehicle Door is Open"

CHIRPS	PROBLEM
1 Chirp	Intelligent Access (IA) key not programmed correctly, or the PEPS Interface Module is damaged.
2 Chirps	BRAKE is being pressed, or the HOOD is open.
3 Chirps	One of the vehicles DOORS are open.
4 Chirps	TACH not programmed.
6 Chirps	The remote start system is in SERVICE/VALET mode.

# '11 Taurus - Push-Button Start

## TYPE "A" CUSTOM WIRE HARNESS

### RMST MODULE WIRE HARNESS

#### DRIVER'S KICK PANEL HARNESS

	Color	Function
A-5	BLACK	Ground
A-11	PINK	Ignition Input/Output
A-1	WHITE	Parking Light Output
A-4	RED	Battery

MAKE THIS CONNECTION FIRST!



CHASSIS GROUND POINT IN DRIVER'S KICK PANEL

SMART JUNCTION BOX

Ignition (VIOLET/GREEN)

Parking Lights (VIOLET/WHITE)

Battery (GREEN/RED)

SJB C2280A PIN 3

SJB C2280E PIN 6

SJB C2280A PIN 10

MAKE THIS CONNECTION LAST!

#### STEERING COLUMN HARNESS

	Color	Function
A-21	BROWN/BLACK	Horn Relay Output

Horn (BLUE/WHITE)

STEERING COLUMN HARNESS

#### BRAKE PEDAL HARNESS

	Color	Function
A-7	BROWN	Brake Input

Brake (VIOLET/WHITE)

BRAKE PEDAL SWITCH

#### START/ STOP SWITCH HARNESS

	Color	Function
A-13	VIOLET	Starter Output

Push Button Start (YELLOW/ORANGE)

START/STOP SWITCH HARNESS

#### UNDER HOOD HARNESS

	Color	Function
A-19	GRAY	Hood Open Switch Input

Vehicle Interior

Engine Compartment

Hood Tilt Switch

Chassis Ground

Do Not Ground to Hood

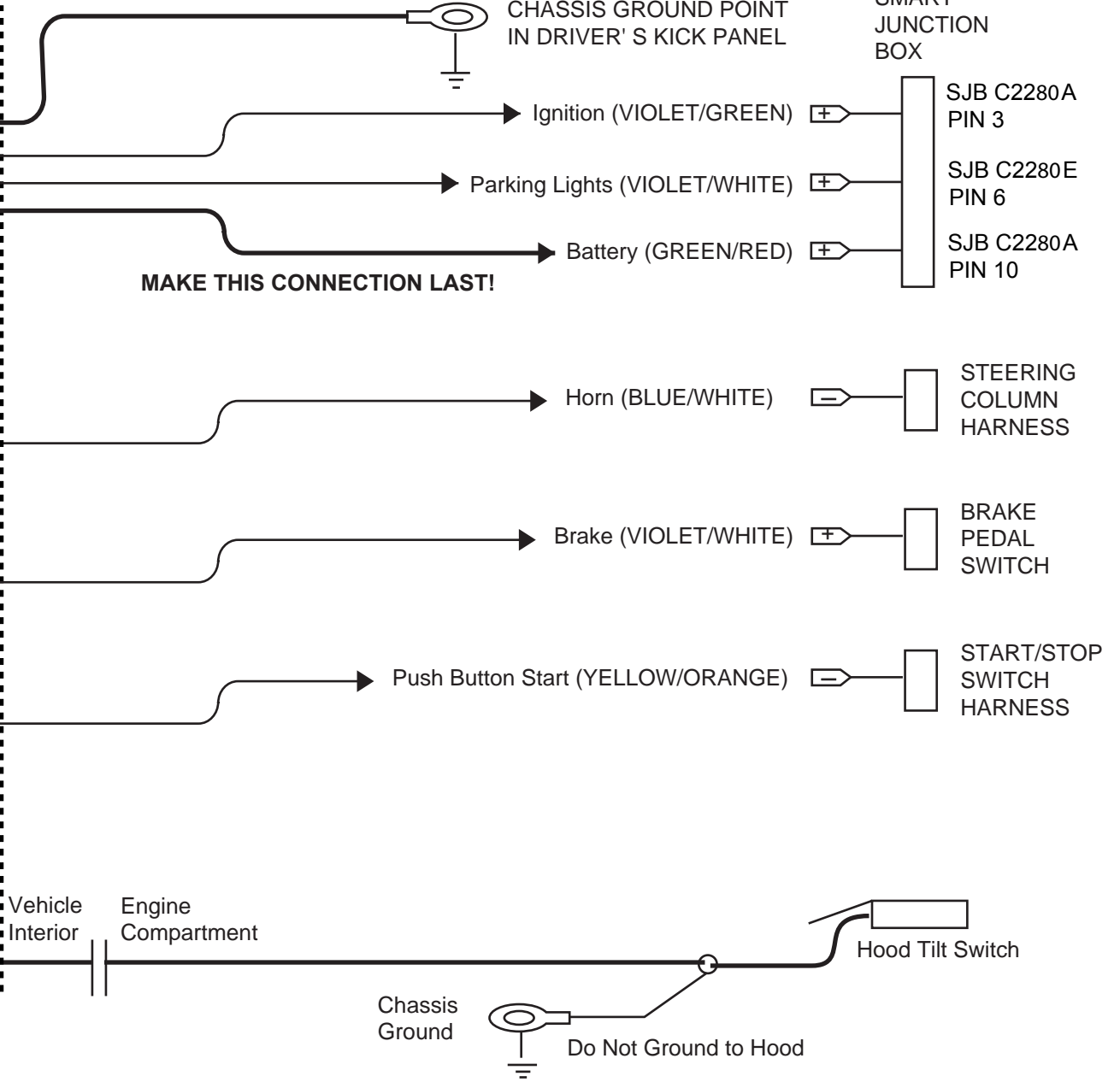
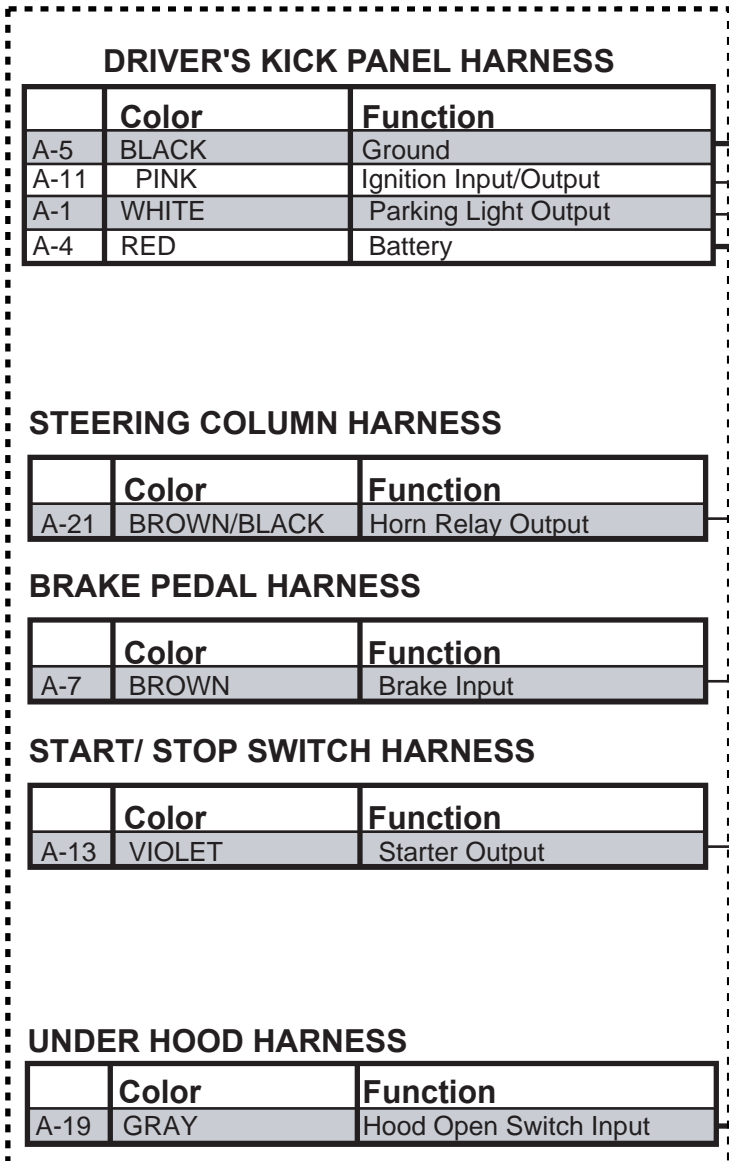

# '11 Taurus - Push-Button Start

## TYPE "A" CUSTOM WIRE HARNESS

### RMST MODULE WIRE HARNESS

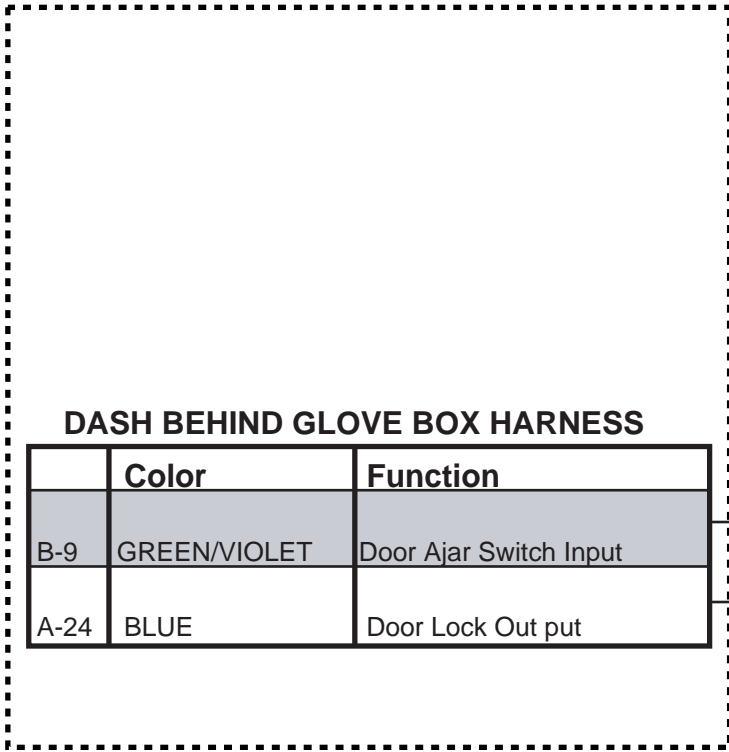

#### DASH BEHIND GLOVE BOX HARNESS

	Color	Function
B-9	GREEN/VIOLET	Door Ajar Switch Input
A-24	BLUE	Door Lock Out put

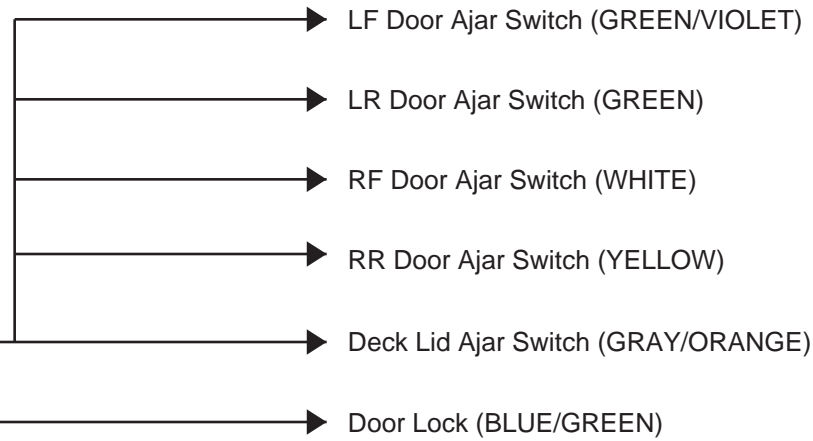

#### REMOTE FUNCTION ACTUATOR (RFA) MODULE

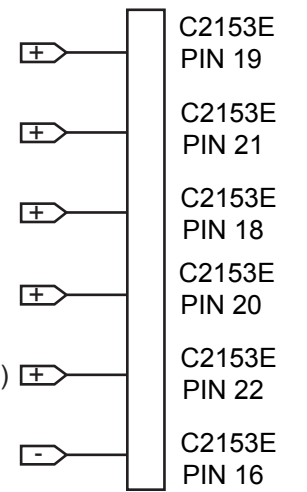

# '11 Taurus - Push-Button Start

Smart Junction Box (SJB)

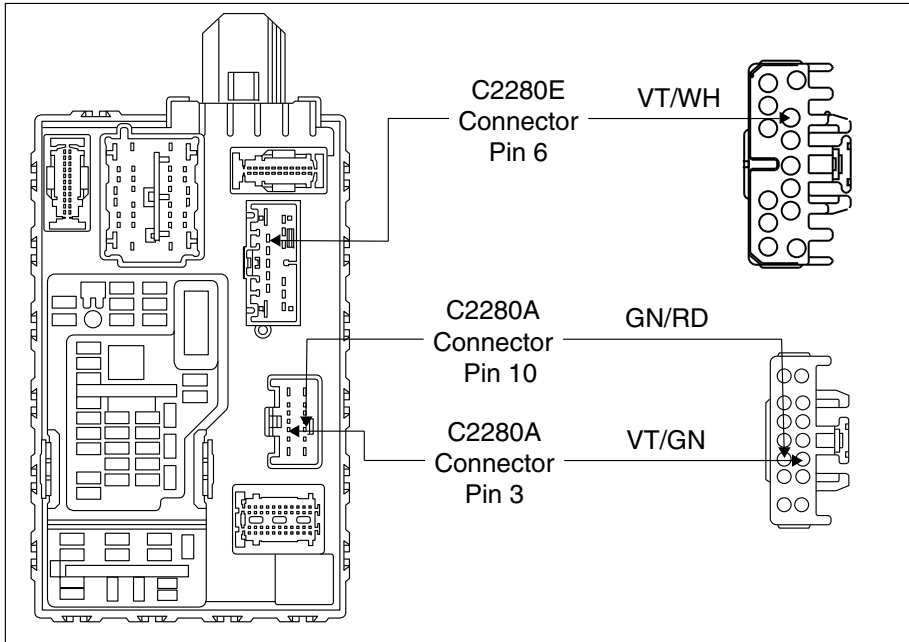

Remote function Actuator (RFA)

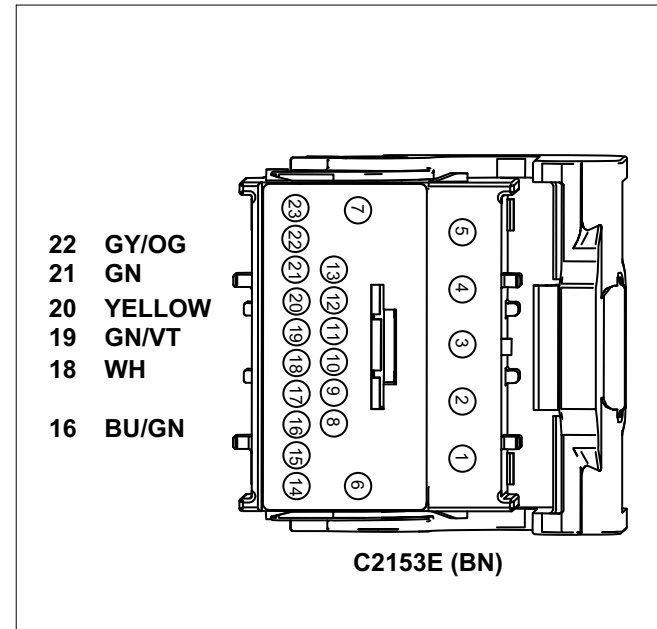

# REMOTE START SYSTEM INSTALLATION

## CONTENTS

### INSTALLATION

[Remote Start](#)

### GENERAL PROCEDURES

[Proper Splicing Techniques](#)

[Programming - Standard Remote Start](#)

[Functional Test - Standard Remote Start](#)

[Programming - Bidirectional Remote Start](#)

[Functional Test - Bidirectional Remote Start](#)

[Troubleshooting](#)

### WIRING DIAGRAMS

[Vehicle Specific Wiring Diagrams](#)

# INSTALLATION

## Remote Start

### Remote Start System RMST Components

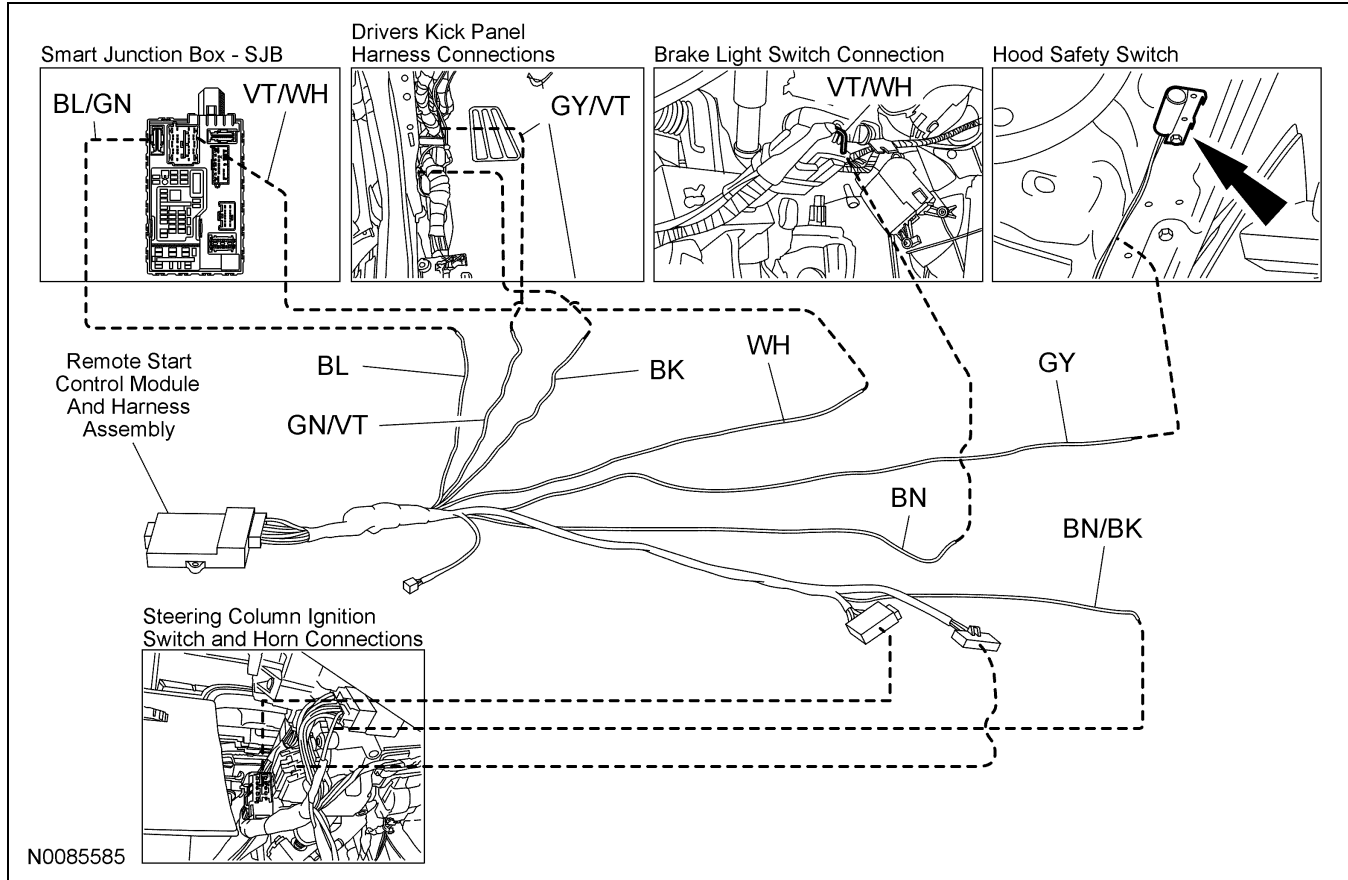

### Focus

**NOTICE:** Remote start systems are only applicable to vehicles with automatic transmissions.

**NOTE:** Both original keys are required for all remote start systems on vehicles equipped with SECURILOCK.

1. Verify correct kit number.

**INSTALLATION (Continued)****Review Remote Start Installation Kit Contents**

**NOTE:** Kits are vehicle specific and are not interchangeable.

- Review the RMST kit contents.

**Remote Start System Standard Kit (RMST) Type - "A"**

QUANTITY	DESCRIPTION
1	TYPE - "A" MODULE ASSEMBLY
1	RMST SOFTWARE CARTRIDGE ASSEMBLY
2	1 BUTTON POWERCODE TRANSMITTER
1	TYPE - "A" CUSTOM WIRING HARNESS
1	ANTENNA
1	HOOD SAFETY SWITCH ASSEMBLY
1	INSTALLATION PARTS BAG
1	FUSE PARTS BAG
1	OPERATORS INSTRUCTIONS
1	OPERATORS QUICK REFERENCE WALLET CARD
1	UNDERHOOD WARNING LABEL
1	SECURILOCK INTERFACE KIT (SOLD SEPARATELY AND REQUIRED FOR VEHICLES W/PATS)

- Review the RMST bidirectional kit contents.

**Remote Start System Bidirectional Kit (RMST) Type - "A"**

QUANTITY	DESCRIPTION
1	TYPE - "A" MODULE ASSEMBLY
1	RMST SOFTWARE CARTRIDGE ASSEMBLY

**Remote Start System Bidirectional Kit (RMST) Type - "A" (Continued)**

QUANTITY	DESCRIPTION
1	2 BUTTON POWERCODE TRANSMITTER
1	TYPE - "A" CUSTOM WIRING HARNESS
1	ANTENNA
1	ANTENNA HARNESS
1	HOOD SAFETY SWITCH ASSEMBLY
1	INSTALLATION PARTS BAG
1	FUSE PARTS BAG
1	OPERATORS INSTRUCTIONS
1	OPERATORS QUICK REFERENCE WALLET CARD
1	UNDERHOOD WARNING LABEL
1	SECURILOCK INTERFACE KIT (SOLD SEPARATELY AND REQUIRED FOR VEHICLES W/PATS)

**Module Preparation**

- Place the supplied fuses into the power distribution block on the remote start control module.
  - Move the polarity jumpers to their proper locations on the control module, see illustration.

INSTALLATION (Continued)

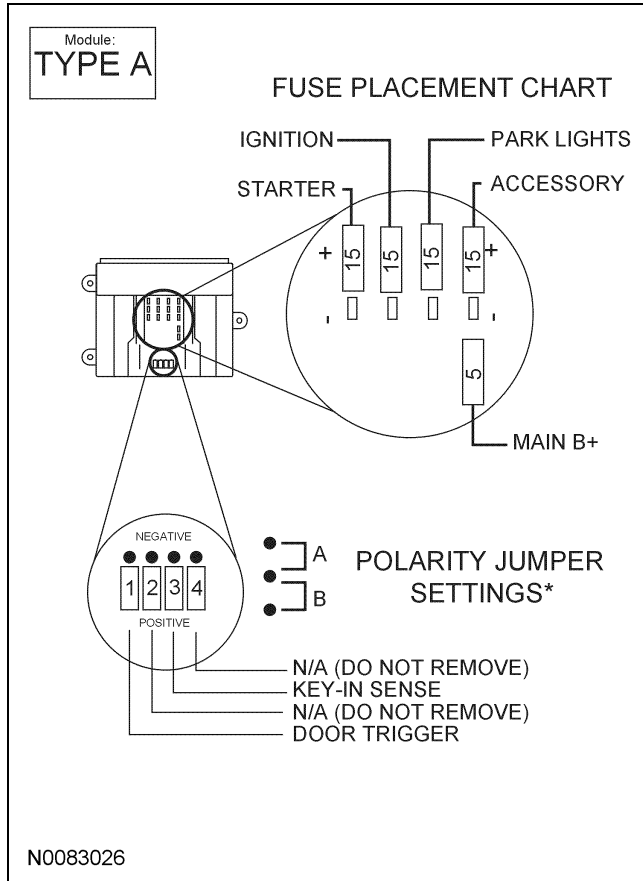

- Place the software cartridge onto the RMST control module.

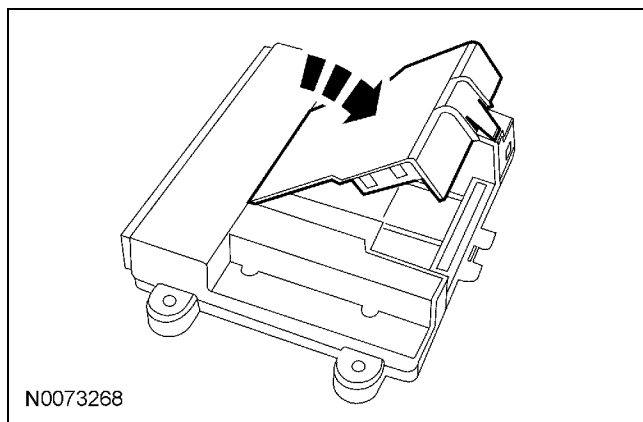

- Plug the wiring harness(es) into the module.
  - A - Harness: 24-way, used on all systems.
  - B - Harness: 10-way, used on all systems with RMST.

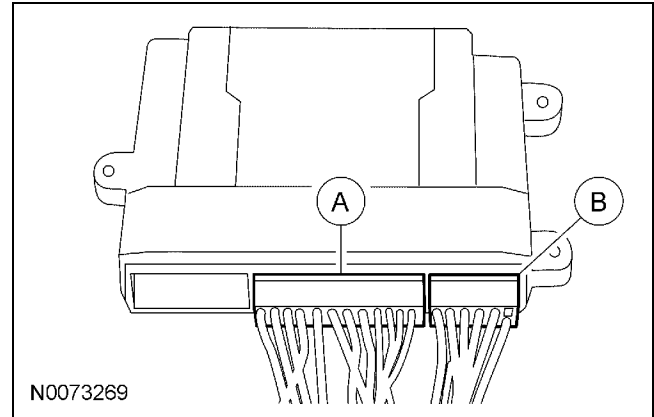

- NOTE:** Do not cut the override programming button off of the harness, it is used for all installations.

**NOTE:** For vehicle specific wiring diagram(s) [click here](#).

Referring to the vehicle specific wiring section for the system being installed, gather all individual wires that will be routed to the same areas of the vehicle into groups. Cover each wire group with electrical tape for approximately 18". Depending on the vehicle, there will be 2 to 5 different wire groups.

Trim the unused wires approximately 6 - 8" from the module.

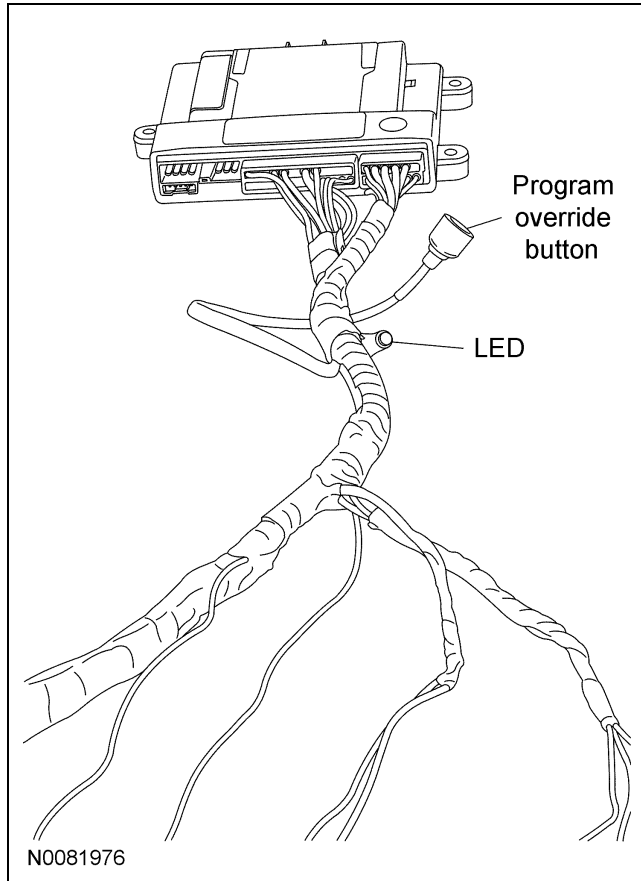

**INSTALLATION (Continued)**

8. Tape the harness sections together, making sure to cover all of the unused wires.

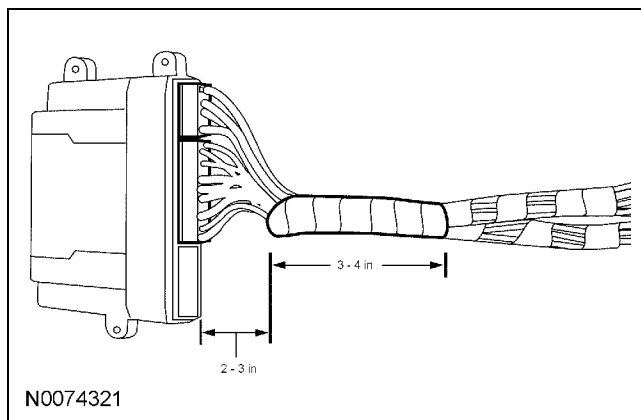
**Vehicle Preparation - All Vehicles**

9. Remove the 3 screws, pull out to release the top retaining clips and remove the lower steering column opening cover.

10. Remove the 3 screws and the upper and lower steering column shrouds.
11. Remove the left hand scuff plate and cowl trim panel.

**Antenna Mounting**

**NOTE:** For good range of operation, the antenna must be installed correctly.

**NOTE:** Keep these points in mind when selecting a location and mounting the antenna.

- Do not mount the antenna behind or on any metal film or window tinting on the windshield.
- Do not mount the antenna so that one of the antenna elements touches or crosses any vehicle wiring and/or metal.
- On vehicles without metal film in the windshield around the rear view mirror, mount the antenna between the headliner and the rear view mirror.
- On vehicles equipped with an electronic mirror, or on vehicles with metal film around the rearview mirror, mount the antenna approximately 3 inches below the mirror attachment point to the windshield and/or mirror electronics.

12. Choose a suitable mounting location following the guidelines above.

**Install The Antenna**

13. Clean the mounting surface using an alcohol base solution and a clean cloth.

14. **NOTE:** Do not touch the adhesive, reduced adhesion may result.

**NOTE:** Make sure that the long wire on the antenna is pointing towards the top of the windshield since this wire will be routed along the headliner.

**NOTE:** The wire will be attached to the control module later in this procedure.

Remove the protective backing from the adhesive on the antenna and firmly press the body of the antenna to the windshield.

**INSTALLATION (Continued)**

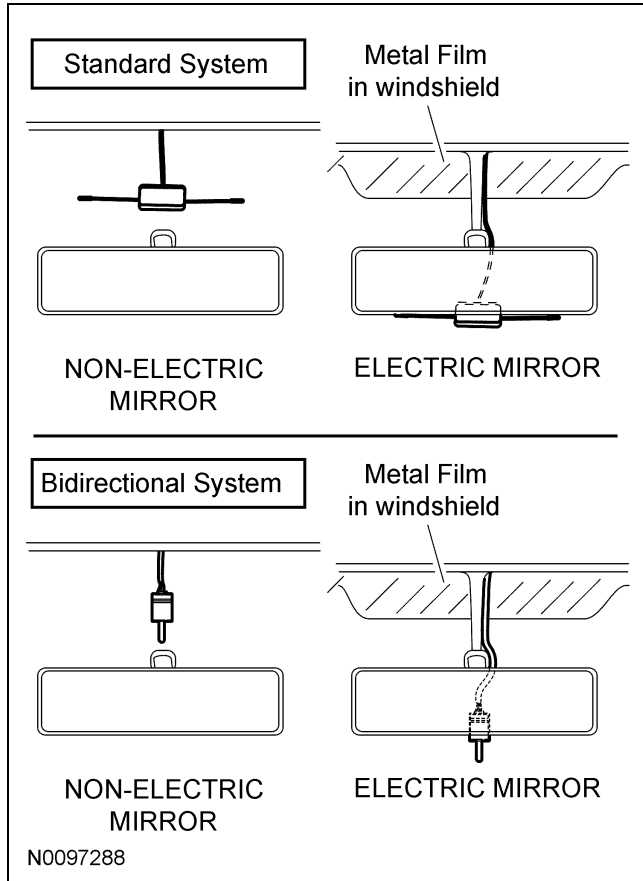

**Install The Securilock Interface Kit**

18. Route the ring of the SECURILOCK interface antenna lead up along the steering column to the PATS transceiver location.

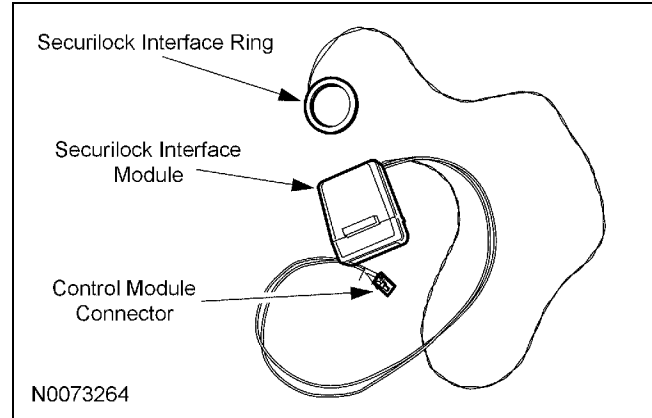

19. Following the directions on the supplied tube of adhesive primer, apply a thin coating around the transceiver antenna coil and allow to dry for approximately 5 minutes.

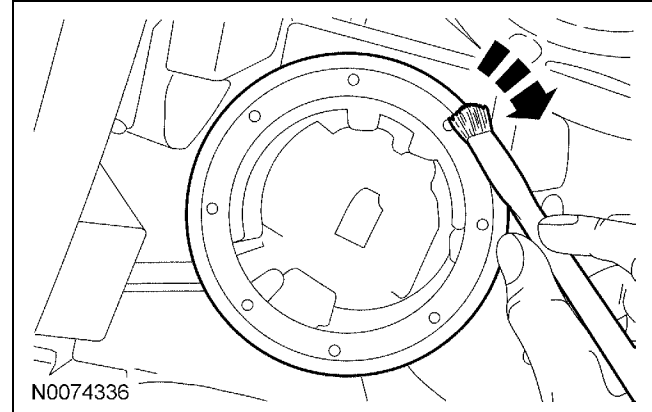

15. If necessary, position the A pillar trim slightly outward to provide access to route the antenna wire.

**NOTE:** Do not route the antenna wire over the top of the air bag.

16. Route the antenna cable along the headliner and down the A pillar towards the floor.

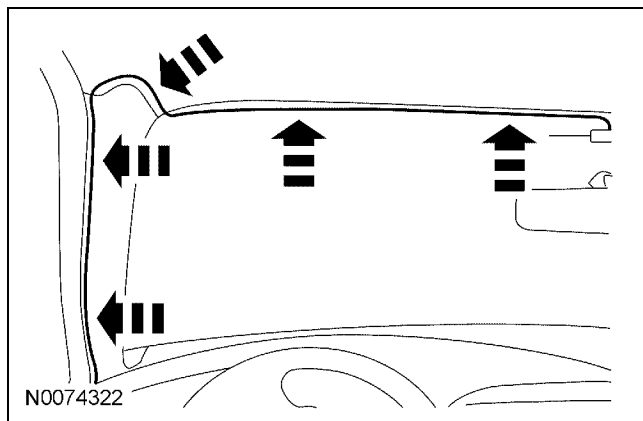

20. **NOTICE:** Do not damage the transceiver ring during installation or while installing the steering column shroud.

**A damaged transceiver ring will result in an inoperable remote start system.**

Remove the protective backing from the SECURILOCK antenna ring. Place the SECURILOCK ring over the PATS transceiver and press firmly in place.

17. Reposition the A pillar trim panel.

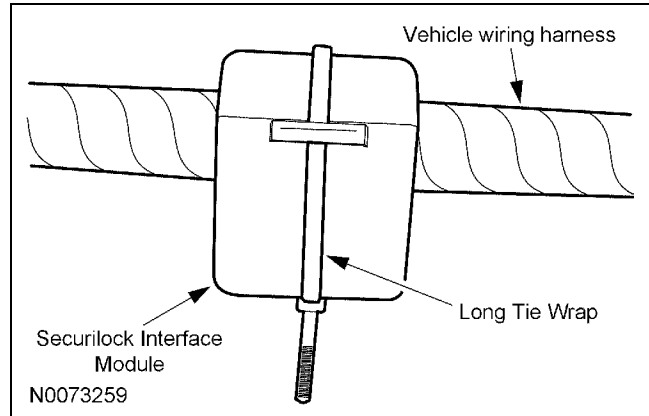
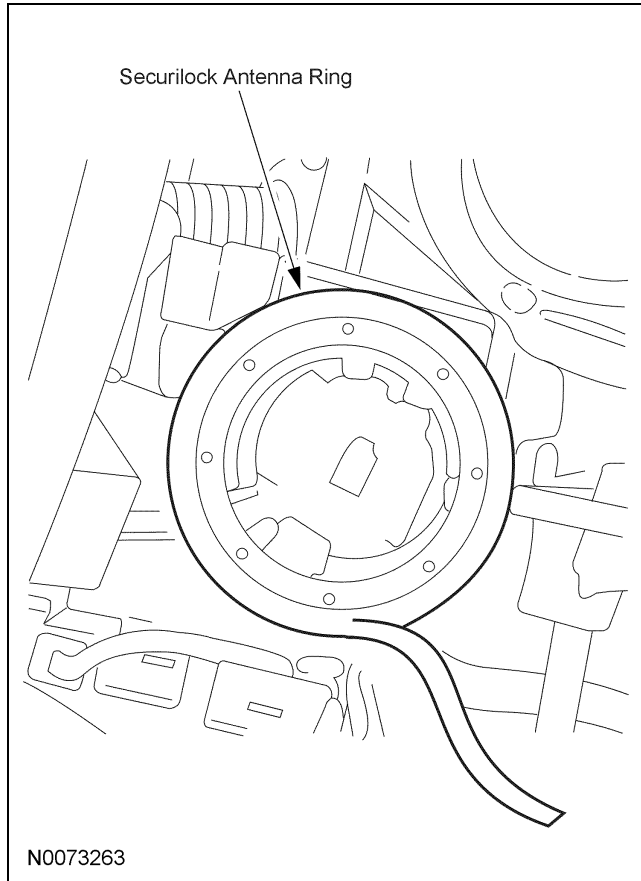
**INSTALLATION (Continued)****Install the Remote Start Control Module and Harness Assembly**

23. Place the remote start module and harness assembly on the floor of the vehicle.

**Identify Circuit Wires For Connections**

**NOTE:** For vehicle specific wiring diagram(s) [click here](#).

**NOTE:** For proper wire splicing techniques [click here](#).

24. Connect the Black ground wire from the remote start module harness to the chassis ground point at the driver kick panel.

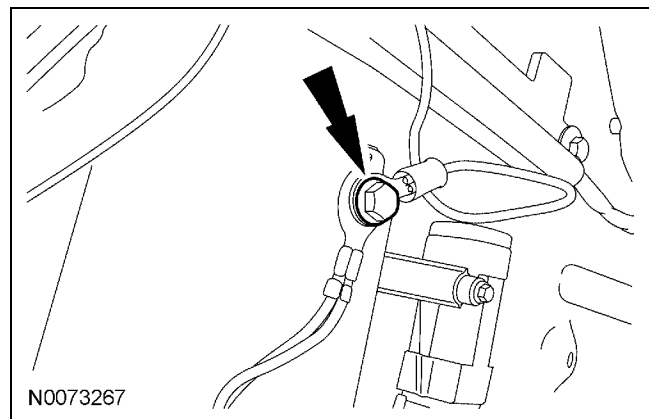
**Install The Securilock Interface Module**

21. **NOTE:** Do Not mount the SECURILOCK Interface Module to or within 3'' of a metal surface, including any underdash brackets, or in the knee bolster area.

Mount the SECURILOCK Interface Module to an underdash wiring harness using one of the supplied long tie wraps.

22. **NOTICE:** Do not attach the harness to the steering column.

Route the harness and connector to the module mounting location.

25. Disconnect the ignition switch electrical connector.
26. Connect the remote start harness hard shell connectors to the ignition switch and ignition switch connector.

**INSTALLATION (Continued)**

27. **NOTE:** A DVOM connected to the correct wire will show 12V, then show 0V when the horn button is held.

A logic probe will show power on the correct wire, then show ground when the horn button is held.

Identify the Blue/White horn circuit wire in the steering column harness.

28. Connect the Brown/Black wire from the remote start module harness to the Blue/White horn circuit wire in the steering column harness.

29. **NOTE:** A DVOM connected to the correct wire will show 12V, then show 0V when the door lock switch is pressed.

A logic probe will show power on the correct wire, then show ground when the door lock switch is pressed.

Identify the Blue/Green power door lock circuit wire at the Smart Junction Box (SJB) connector C2280C pin 17.

30. Connect the Blue wire from the remote start module harness to the Blue/Green power door lock circuit at the SJB connector C2280C pin 17.

31. **NOTE:** A DVOM connected to the correct wire will show 0V, then show 12V while depressing the brake pedal.

A logic probe will show ground on the correct wire, then show power while depressing the brake pedal.

Identify the Violet/White brake switch circuit wire at the brake switch.

32. Connect the Brown wire from the remote start module harness to the Violet/White brake switch circuit wire at the brake switch.

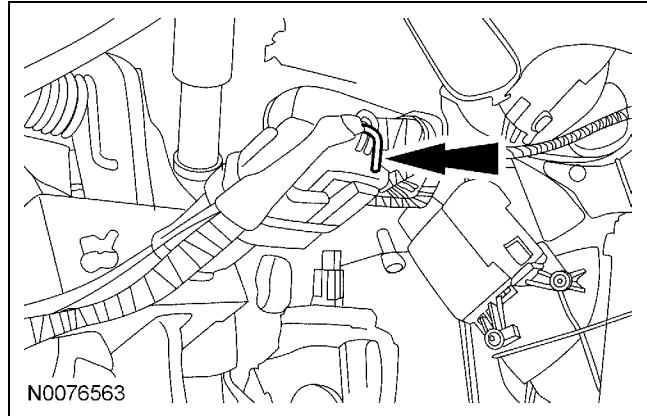

33. **NOTE:** A DVOM connected to the correct wire will show 12V with the vehicle door(s) open and the dome light ON, then show 0V with the vehicle door(s) closed and the dome light OFF.

**NOTE:** A logic probe connected to the correct wire will show power with the vehicle door(s) open and the dome light ON, then show ground with the vehicle door(s) closed and the dome light OFF.

**NOTE:** Be sure that the dome light has timed out and is OFF before performing the door closed test.

Be sure that the dome lamp is illuminated before performing the door open test.

Identify the Grey/Violet dome light circuit wire at the driver kick panel connector C214A pin 7.

34. Connect the Green/Violet wire from the remote start module harness to the Grey/Violet dome light circuit wire at the driver kick panel connector C214A pin 7.

35. **NOTE:** A DVOM connected to the correct wire will show 0V with the head lamps switch in the OFF position, then show 12V with the head lamp switch in the parking lights ON position.

**NOTE:** A logic probe will show ground with the head lamp switch in the OFF position and power with the switch in the parking lamps ON position.

Identify the Violet/White parking lights circuit wire at the SJB connector C2280E pin 6.

36. Connect the White wire from the remote start module harness to the Violet/White parking lights circuit wire at the SJB connector C2280E pin 6.

**INSTALLATION (Continued)****Install The Hood Safety Switch**

37. **NOTE:** Route the hood safety switch wire carefully avoiding any moving parts or components that can produce excessive heat.

**NOTE:** Using a piece of convolute adds in the appearance of the installation.

**NOTE:** The switch should be positioned about 30 degrees below parallel to the ground to accommodate for parking on inclines.

Failure to position the switch properly could result in one of the following:

- False alarm trips
- Non-Remote Start events
- Inadvertent shutdown during Remote Start

Locate an easy to access area near the driver side hood hinge and install the hood safety switch using the supplied metal screws.

38. Apply rustproofing compound (PM-13-A) to the drilled hole and torque the screw to 1.00 Nm (10 lb-in).

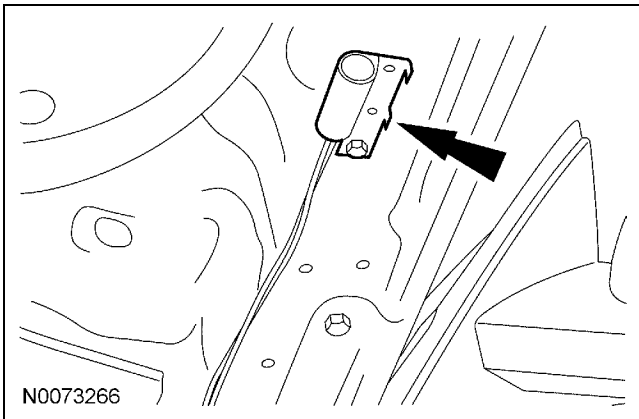

39. Connect hood switch ground wire to a suitable location on the bulkhead.

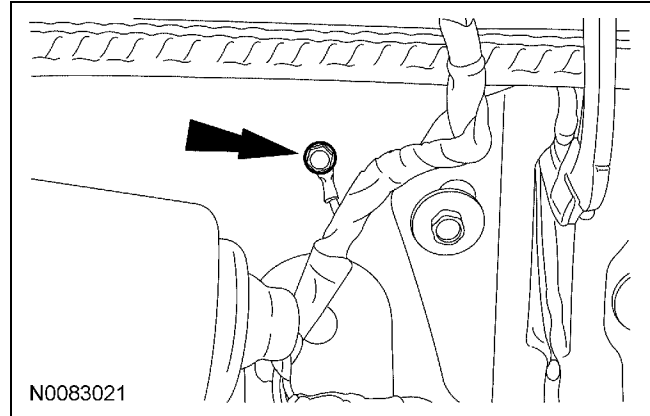

40. **NOTE:** Place the label on the radiator fan shroud or similar area.

Install the underhood warning label

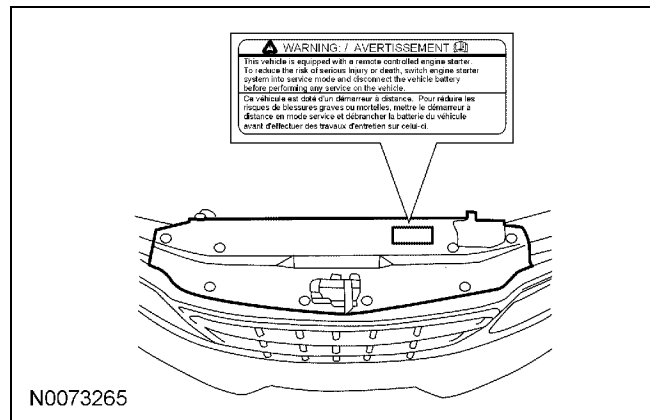

41. Route the Gray hood safety switch wire through the bulkhead into the engine compartment and attach to the hood safety switch.

42. Connect the antenna to the RMST control module.

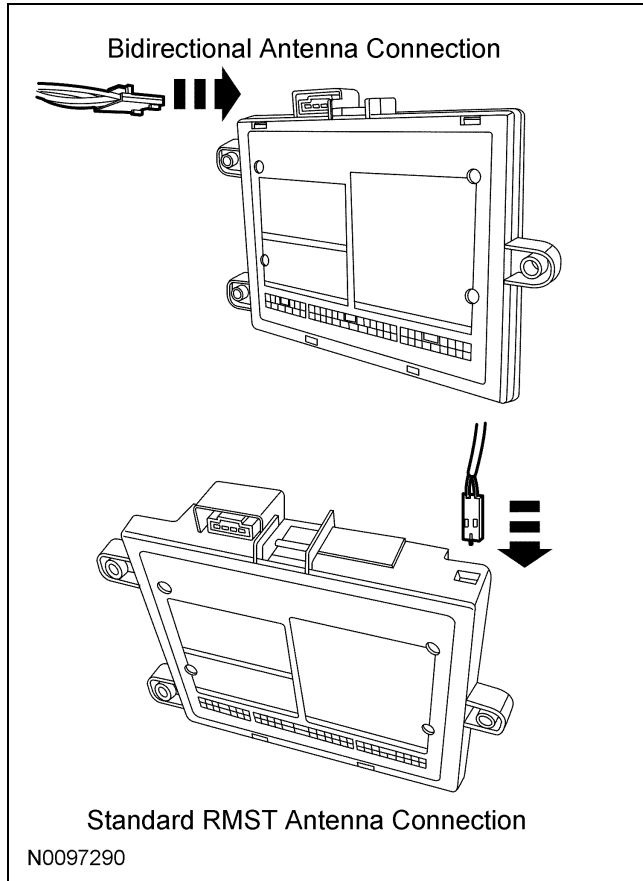
**INSTALLATION (Continued)**

43. Connect the SECURILOCK interface module to the RMST control module.

**Program The RMST System**

44. Refer to the RMST programming section for this vehicle [click here](#).

**Secure RMST Harness and Control Module**

45. Use the supplied tie wraps to secure the RMST harness wires.
46. **NOTE:** Do not mount the control module in the knee bolster area.
- Secure the control module at three points to the vehicle.
- Use the supplied long tie wraps to mount the RMST control module to the underdash wiring harness.

**All Vehicles**

47. Install the left hand scuff plate and cowl trim panel.
48. Install the upper and lower steering column shrouds.
- Install the 3 screws.

## GENERAL PROCEDURES

### Programming - Standard Remote Start

#### Programming the Module

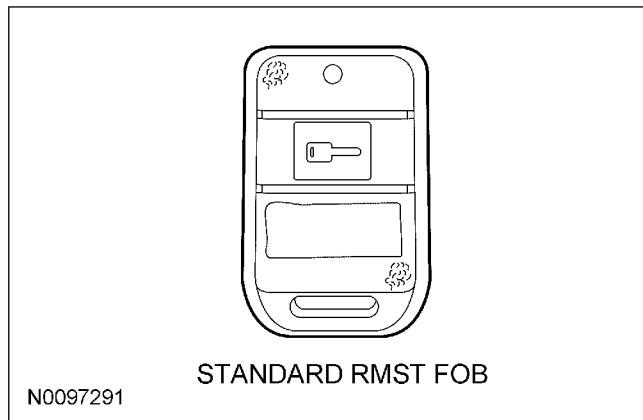

- NOTE:** If the remote start options (Key-in sense polarity, door ajar polarity, or tach mode) are not programmed correctly, vehicle will not remote start or operate properly.

**NOTE:** Make sure that the hood and doors are closed before proceeding.

**NOTE:** The LED on the remote start harness must be visible to complete module programming.

**NOTE:** The remote start override button must be accessible.

#### Programming Options: Entering Programming Mode

- See chart below for programming information.

#### Program Bank 2 Chart (5 Honks)

BANK	OPTIONS	DESCR	LED
2	1	TACHLESS MODE	ON

- Press and hold the brake pedal.
- Turn the ignition key to the RUN position.  
The dome light will turn off.

- Press and hold the remote start system override button for at least 10 seconds.

After 10 seconds the horn will honk 3 times, indicating the system is now in the learn mode.

Release the brake pedal and the RMST override button.

- Press and release the override button. The horn will honk 4 times indicating the system has entered the first program bank.

If not, please check the following:

- Brake pedal switch wire solder connection.
- Hood closed and Grey hood safety switch wire solder connection.
- All doors closed and dome light circuit wire solder connections.
- The key is in the RUN position.
- The software cartridge is firmly seated in the RMST module.
- The RMST harness connections are firmly seated in the RMST module.

**NOTE:** If you require additional assistance: CALL 1-800-FORD KEY.

- Press and release the override button again. The horn will honk 5 times indicating the system has entered the second program bank.
- Press and release the brake pedal.  
The horn will honk 1 time indicating the system has entered the option 1 of the second program bank.

**NOTICE:** When turning LED on or off using remote start fob button quickly press and immediately release the remote start button.

**Failure to quickly release the remote start fob button will result in system defaulting to the factory options.**

- The LED must be on for option 1. If the LED is illuminated no action is required. If the LED is not illuminated press the remote start fob button and verify the LED illuminates.

**GENERAL PROCEDURES (Continued)**

**NOTE:** If the remote start fob button is held for more than 3 seconds the system will chirp the horn 4 times, indicating the system has returned to factory default settings. If this occurs return to step 1 of the programming section and reprogram the remote start module.

**NOTE:** The remote start module is now programmed.

10. Remove the ignition key.

**Programming the SECURILOCK**

**NOTE:** Two PATS keys are required to program the SECURILOCK.

**NOTE: IMPORTANT:** Each of the following steps should be completed with no more than 5 seconds delay between steps.

11. Insert the first ignition key and turn to the run position.

Watch for the PATS light to turn off. Remove the first key.

12. Insert the second ignition key and turn to the run position.

Watch for the PATS light to turn off. Remove the second key.

13. Press and hold the remote start button



for 3 seconds.  
The PATS light should stay on for 3-5 seconds before turning off, which means that the SECURILOCK was successfully programmed.

**NOTE:** If the PATS light blinks rapidly, repeat steps 1-3 to retry programming the SECURILOCK.

**NOTE:** The engine will start if the Remote Start kit has been installed correctly, the brake is not depressed, and the hood and doors are closed.



## GENERAL PROCEDURES

### Functional Test - Standard Remote Start

**NOTE:** If during any of the steps of the functional test, the remote start system or vehicle doesn't react or perform accordingly, please refer to the remote start troubleshooting guide.

**NOTE:** For remote start troubleshooting guide click [here](#).

1. Make sure all doors are closed but hood is open and windows are down (doors will be locking).
2. Press and hold the Start button on the remote control key fob for 2-3 seconds - Horn should honk once indicating receipt of the start request.
3. The remote start systems should turn on the ignition, but then honk the horn twice and shut down indicating the hood is open.
4. Close the hood, and insert a key into the ignition switch.
5. Attempt to re-start the vehicle again using the key fob.
6. The remote start systems should turn on the ignition, but then honk the horn five times and shut down indicating a key is in the ignition switch.
7. Remove the key and open a door.
8. Attempt to re-start the vehicle again using the key fob.
9. The remote start systems should turn on the ignition, but then honk the horn three times and shut down indicating a door is open.
10. Close the door.
11. Attempt to re-start the vehicle again using the key fob.

12. Once the vehicle starts, verify that all heat and A/C functions operate normally and that the doors have locked.
13. On vehicles equipped with power window interrupt, Attempt to close windows to check power window interrupt function.
14. Once all systems have been checked, open the door\*, or press the brake pedal - the remote start systems should shut down.

**NOTE:** \*MyKey vehicle remote start systems will shut down upon vehicle entry. Please see vehicle owner's guide or remote start owner's manual for more information.

### Troubleshooting

15. **NOTE:** When attempting to remote start your vehicle, the system has several safety checks that it performs. If any of these inputs are present that should not be, the system will respond back to you with several horn "chirps" to help you identify which input is present. These "chirps" will occur after initiating a start sequence with the transmitter, the system will turn on the ignition, but then respond back with several horn "chirps" and abort the starting process.

**Example:** Depress the remote start fob button for 3 seconds and then release. The vehicle horn will "chirp" one time to indicate that RMST signal was received. If the vehicle doesn't start and the horn "chirps" 3 times, there is a fault - "Vehicle Door is Open"

CHIRPS	PROBLEM
1 Chirp	SECURILOCK not programmed correctly, or the SECURILOCK antenna ring is damaged.
2 Chirps	BRAKE is being pressed, or the HOOD is open.
3 Chirps	One of the vehicles DOORS are open.
4 Chirps	TACH not programmed.

---

**GENERAL PROCEDURES (Continued)**

<b>CHIRPS</b>	<b>PROBLEM</b>
5 Chirps	The KEY is in the ignition.
6 Chirps	The remote start system is in SERVICE/VALET mode.

---

## GENERAL PROCEDURES

### Programming - Bidirectional Remote Start

#### Programming the Module

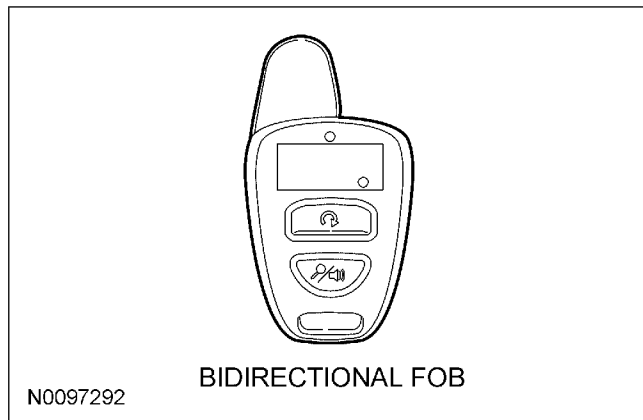

- NOTE:** If the remote start options (Key-in sense polarity, door ajar polarity, or tach mode) are not programmed correctly, vehicle will not remote start or operate properly.

**NOTE:** Make sure that the hood and doors are closed before proceeding.

**NOTE:** The LED on the remote start harness must be visible to complete module programming.

**NOTE:** The remote start override button must be accessible.

#### Programming Options: Entering Programming Mode

- See chart below for programming information.

#### Program Bank 2 Chart (5 Honks)

BANK	OPTIONS	DESCR	LED
2	1	TACHLESS MODE	ON

- Press and hold the brake pedal.
- Turn the ignition key to the RUN position.  
The dome light will turn off.

- Press and hold the remote start system override button for at least 10 seconds.

After 10 seconds the horn will honk 3 times, indicating the system is now in the learn mode.

Release the brake pedal and the RMST override button.

- Press and release the override button. The horn will honk 4 times indicating the system has entered the first program bank.

If not, please check the following:

- Brake pedal switch wire solder connection.
- Hood closed and Grey hood safety switch wire solder connection.
- All doors closed and dome light circuit wire solder connections.
- The key is in the RUN position.
- The software cartridge is firmly seated in the RMST module.
- The RMST harness connections are firmly seated in the RMST module.

**NOTE:** If you require additional assistance: CALL 1-800-FORD KEY.

- Press and release the override button again. The horn will honk 5 times indicating the system has entered the second program bank.

- Press and release the brake pedal.

The horn will honk 1 time indicating the system has entered the option 1 of the second program bank.

**NOTICE:** When turning LED on or off using remote start fob button quickly press and immediately release the remote start button.

**Failure to quickly release the remote start fob button will result in system defaulting to the factory options.**

- The LED must be on for option 1. If the LED is illuminated no action is required. If the LED is not illuminated press the remote start fob button and verify the LED illuminates.

**GENERAL PROCEDURES (Continued)**

**NOTE:** If the remote start fob button is held for more than 3 seconds the system will chirp the horn 4 times, indicating the system has returned to factory default settings. If this occurs return to step 1 of the programming section and reprogram the remote start module.

**NOTE:** The remote start module is now programmed.

10. Remove the ignition key.

**Programming the SECURILOCK**

**NOTE:** Two PATS keys are required to program the SECURILOCK.

**NOTE: IMPORTANT:** Each of the following steps should be completed with no more than 5 seconds delay between steps.

11. Insert the first ignition key and turn to the run position.

Watch for the PATS light to turn off. Remove the first key.

---

12. Insert the second ignition key and turn to the run position.

Watch for the PATS light to turn off. Remove the second key.

13. Press the remote start button  twice within 3 seconds.

The PATS light should stay on for 3-5 seconds before turning off, which means that the SECURILOCK was successfully programmed.

**NOTE:** If the PATS light blinks rapidly, repeat steps 1-3 to retry programming the SECURILOCK.

**NOTE:** The engine will start if the Remote Start kit has been installed correctly, the brake is not depressed, and the hood and doors are closed.

## GENERAL PROCEDURES

### Functional Test - Bidirectional Remote Start

**NOTE:** If during any of the steps of the functional test, the remote start system or vehicle doesn't react or perform accordingly, please refer to the remote start troubleshooting guide.

**NOTE:** For remote start troubleshooting guide click [here](#).

1. Make sure all doors are closed but hood is open and windows are down (doors will be locking).
2. Press the Start button on the remote control key fob twice within 3 seconds - Horn should honk once indicating receipt of the start request.
3. The remote start systems should turn on the ignition, but then honk the horn twice and shut down indicating the hood is open.
4. Close the hood, and insert a key into the ignition switch.
5. Attempt to re-start the vehicle again using the key fob.
6. The remote start systems should turn on the ignition, but then honk the horn five times and shut down indicating a key is in the ignition switch.
7. Remove the key and open a door.
8. Attempt to re-start the vehicle again using the key fob.
9. The remote start systems should turn on the ignition, but then honk the horn three times and shut down indicating a door is open.
10. Close the door.
11. Attempt to re-start the vehicle again using the key fob.

12. Once the vehicle starts, verify that all heat and A/C functions operate normally and that the doors have locked.
13. On vehicles equipped with power window interrupt, Attempt to close windows to check power window interrupt function.
14. Once all systems have been checked, open the door\*, or press the brake pedal - the remote start systems should shut down.

**NOTE:** \*MyKey vehicle remote start systems will shut down upon vehicle entry. Please see vehicle owner's guide or remote start owner's manual for more information.

### Troubleshooting

15. **NOTE:** When attempting to remote start your vehicle, the system has several safety checks that it performs. If any of these inputs are present that should not be, the system will respond back to you with several horn "chirps" to help you identify which input is present. These "chirps" will occur after initiating a start sequence with the transmitter, the system will turn on the ignition, but then respond back with several horn "chirps" and abort the starting process.

**Example:** Depress the remote start fob button for 3 seconds and then release. The vehicle horn will "chirp" one time to indicate that RMST signal was received. If the vehicle doesn't start and the horn "chirps" 3 times, there is a fault - "Vehicle Door is Open"

CHIRPS	PROBLEM
1 Chirp	SECURILOCK not programmed correctly, or the SECURILOCK antenna ring is damaged.
2 Chirps	BRAKE is being pressed, or the HOOD is open.
3 Chirps	One of the vehicles DOORS are open.
4 Chirps	TACH not programmed.

'11 Focus

TYPE "A" CUSTOM WIRE HARNESS

RMST MODULE WIRE HARNESS

STEERING COLUMN HARNESS

	Color	Function
A-3	PINK	Ignition Input/Output
A-2	ORANGE	HVAC Output
A-13	VIOLET	Starter Output
B-8	BLACK/WHITE	Key-in-sense Input
A-4	RED	Battery

	Color	Function
A-21	BROWN/BLACK	Horn Relay Output
A-1	WHITE	Parking Light Output

DRIVER'S KICK PANEL HARNESS

	Color	Function
A-5	BLACK	Ground
A-24	BLUE	Door Lock Output
B-7	BROWN	Brake Input
A-20	GREEN/VIOLET	Door Ajar Switch Input

UNDER HOOD HARNESS

	Color	Function
A-19	GRAY	Hood Open Switch Input

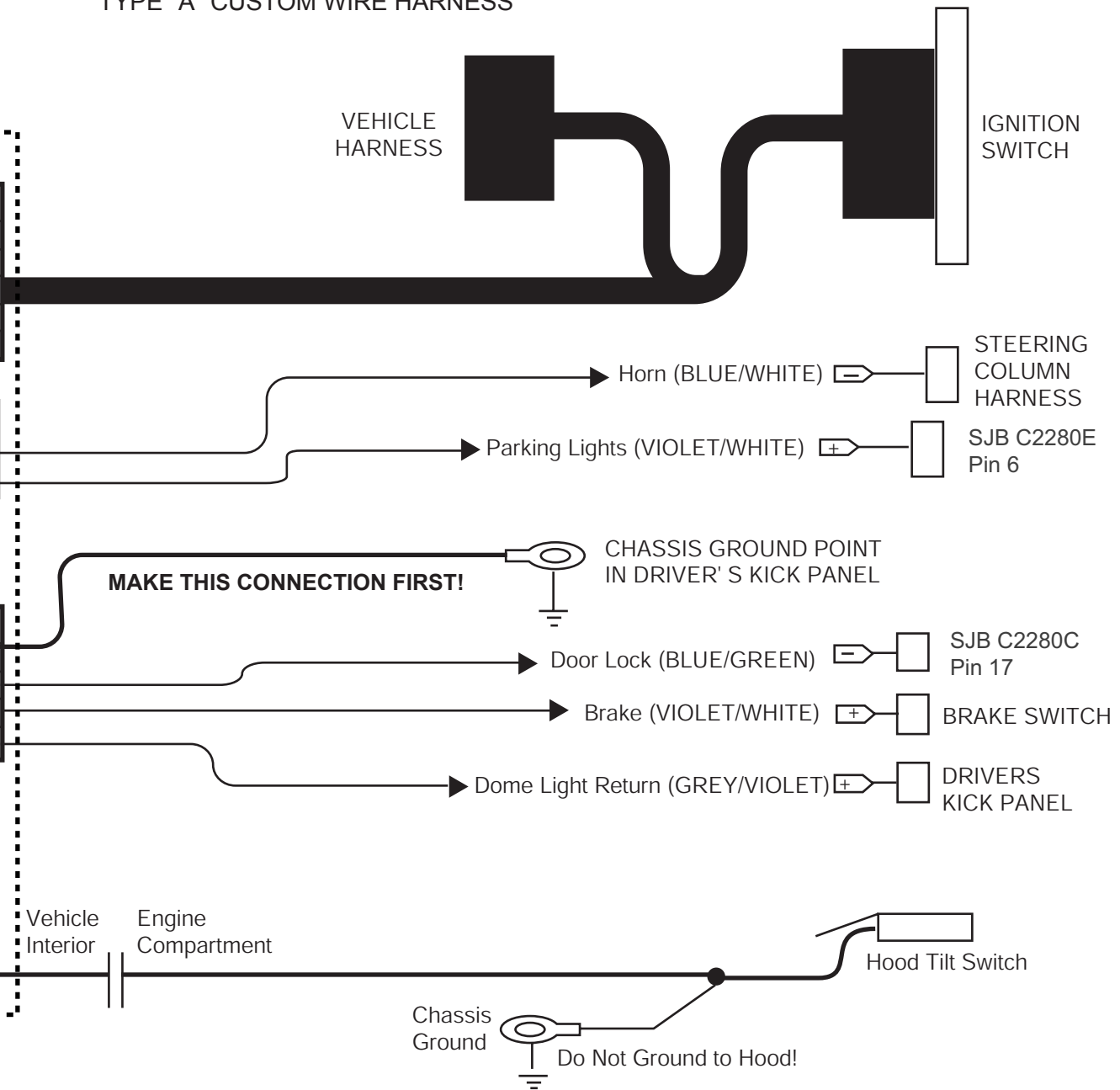

[Manual Table of Contents](#)

## REMOTE START SYSTEM INSTALLATION

### CONTENTS

#### [INSTALLATION](#)

[Remote Start](#)

#### [GENERAL PROCEDURES](#)

[Proper Splicing Techniques](#)

[Programming - Standard Remote Start](#)

[Functional Test - Standard Remote Start](#)

[Programming - Bidirectional Remote Start](#)

[Functional Test - Bidirectional Remote Start](#)

[Troubleshooting](#)

#### [WIRING DIAGRAMS](#)

[Vehicle Specific Wiring Diagrams](#)

**INSTALLATION**

**Remote Start**

**Remote Start System RMST Components**

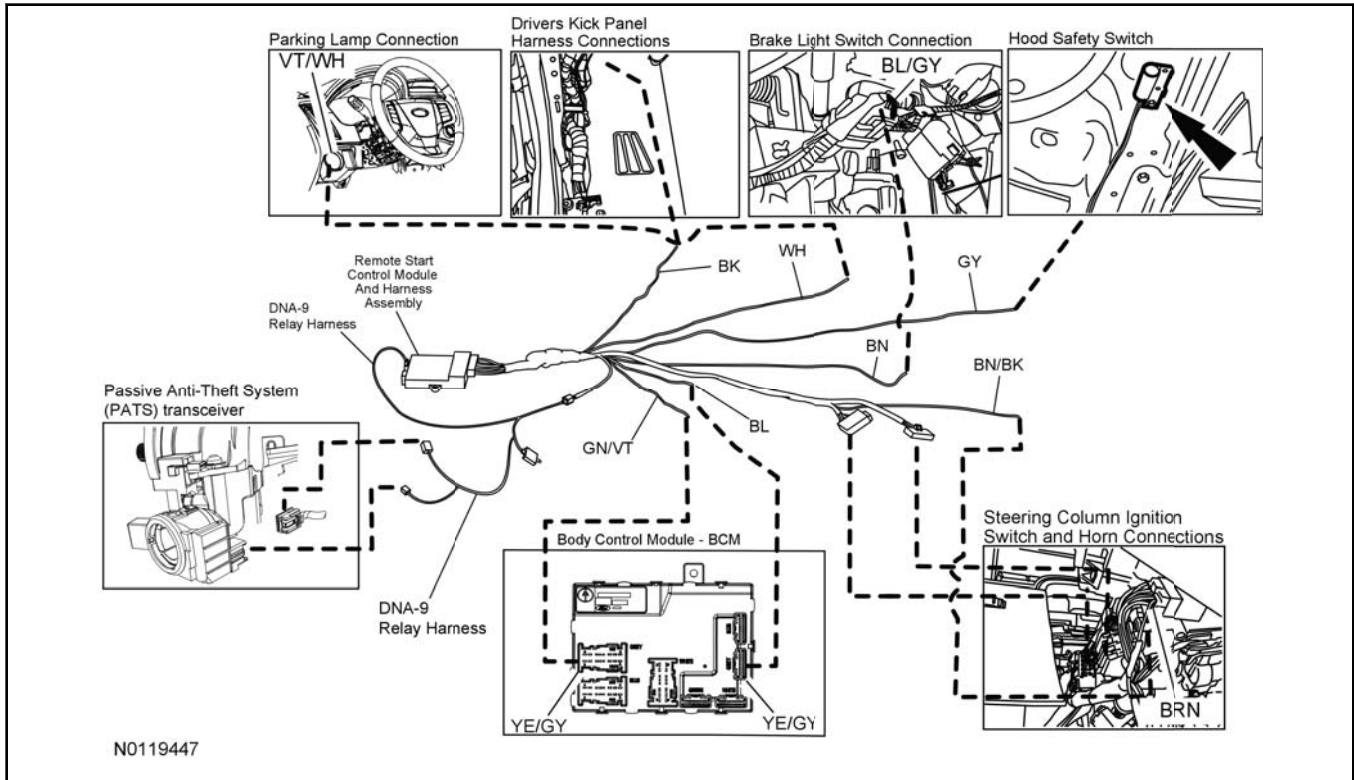

**Fiesta - Key Start**

**NOTICE:**

Remote start systems are only applicable to vehicles with automatic transmissions.

1. Verify correct kit number.

**Review Remote Start Installation Kit Contents**

**NOTE:**

Kits are vehicle specific and are not interchangeable.

2. Review the RMST kit contents.

**Remote Start System Standard Kit (RMST) Type - "A"**

QUANTITY	DESCRIPTION
1	TYPE - "A" MODULE ASSEMBLY
1	RMST SOFTWARE CARTRIDGE ASSEMBLY
2	1 BUTTON POWER CODE TRANSMITTER
1	TYPE - "A" CUSTOM WIRING HARNESS



**INSTALLATION (Continued)**

**Remote Start System Standard Kit (RMST) Type - "A"(Continued)**

1	ANTENNA
1	HOOD SAFETY SWITCH ASSEMBLY
1	INSTALLATION PARTS BAG
1	FUSE PARTS BAG
1	OPERATORS INSTRUCTIONS
1	UNDERHOOD WARNING LABEL
1	DNA-9 Module
1	DNA-9 Relay Harness

- Review the RMST bidirectional kit contents.

**Remote Start System Bidirectional Kit (RMST) Type - "A"**

QUANTITY	DESCRIPTION
1	TYPE - "A" MODULE ASSEMBLY
1	RMST SOFTWARE CARTRIDGE ASSEMBLY
1	2 BUTTON POWER CODE TRANSMITTER
1	TYPE - "A" CUSTOM WIRING HARNESS
1	ANTENNA
1	ANTENNA HARNESS
1	HOOD SAFETY SWITCH ASSEMBLY
1	INSTALLATION PARTS BAG
1	FUSE PARTS BAG
1	OPERATORS INSTRUCTIONS
1	UNDERHOOD WARNING LABEL
1	DNA-9 Module
1	DNA-9 Relay Harness

**Module Preparation**

- Place the supplied fuses into the power distribution block on the remote start control module.
  - Move the polarity jumpers to their proper locations on the control module, see illustration.

**INSTALLATION (Continued)**

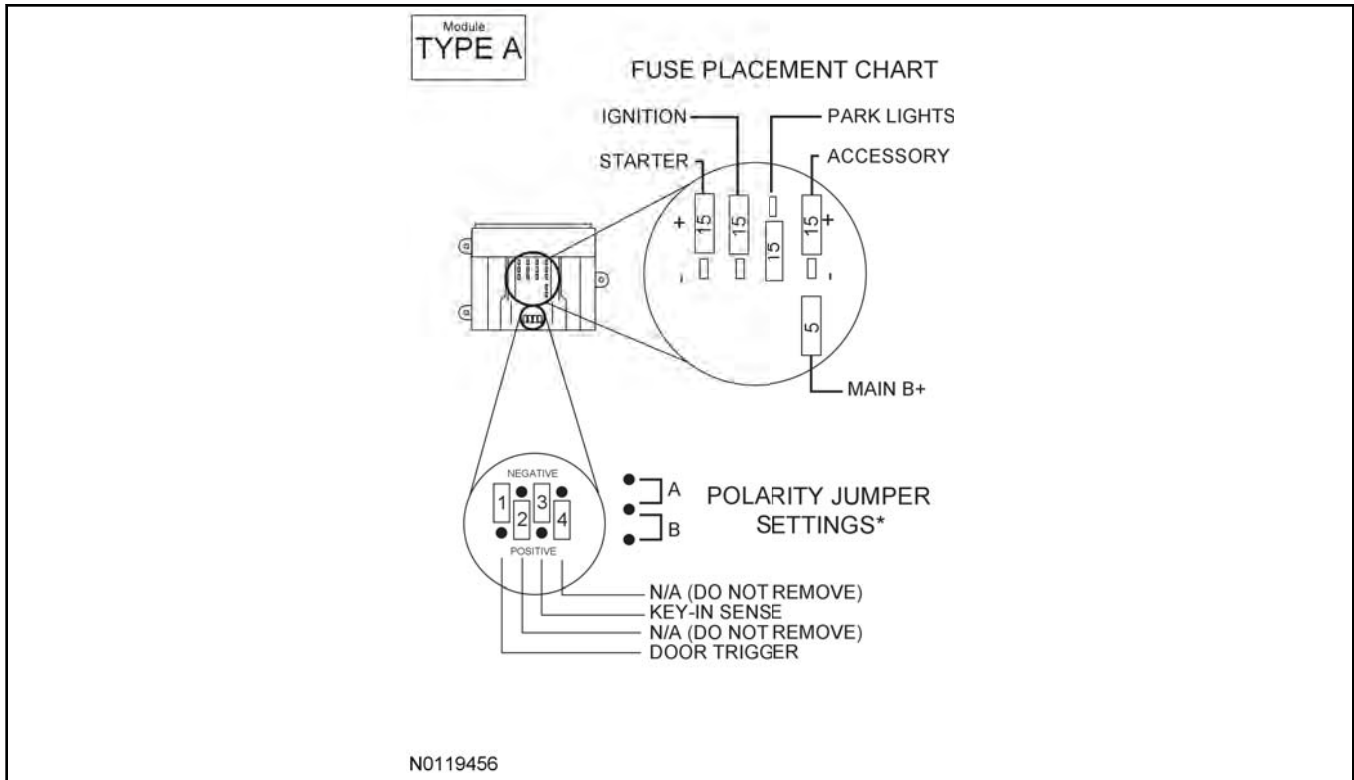

5. Place the software cartridge onto the RMST control module.

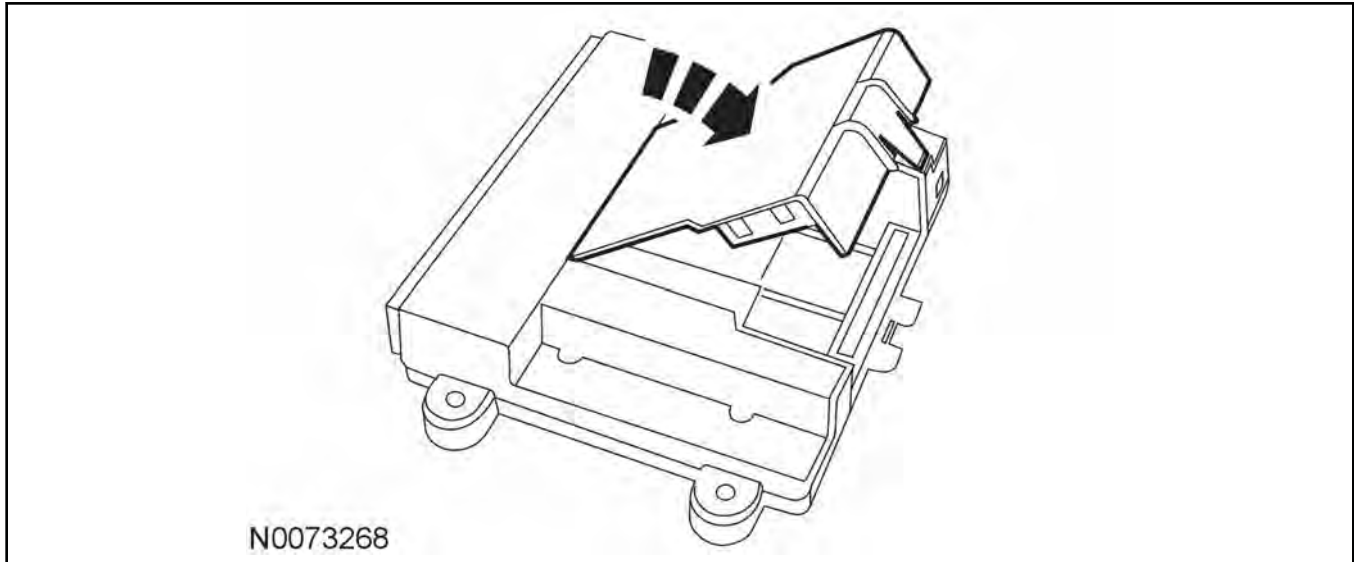

6. Plug the wiring harness(es) into the module.
- A - Harness: 24-way, used on all systems.
  - B - Harness: 10-way, used on all systems with RMST.

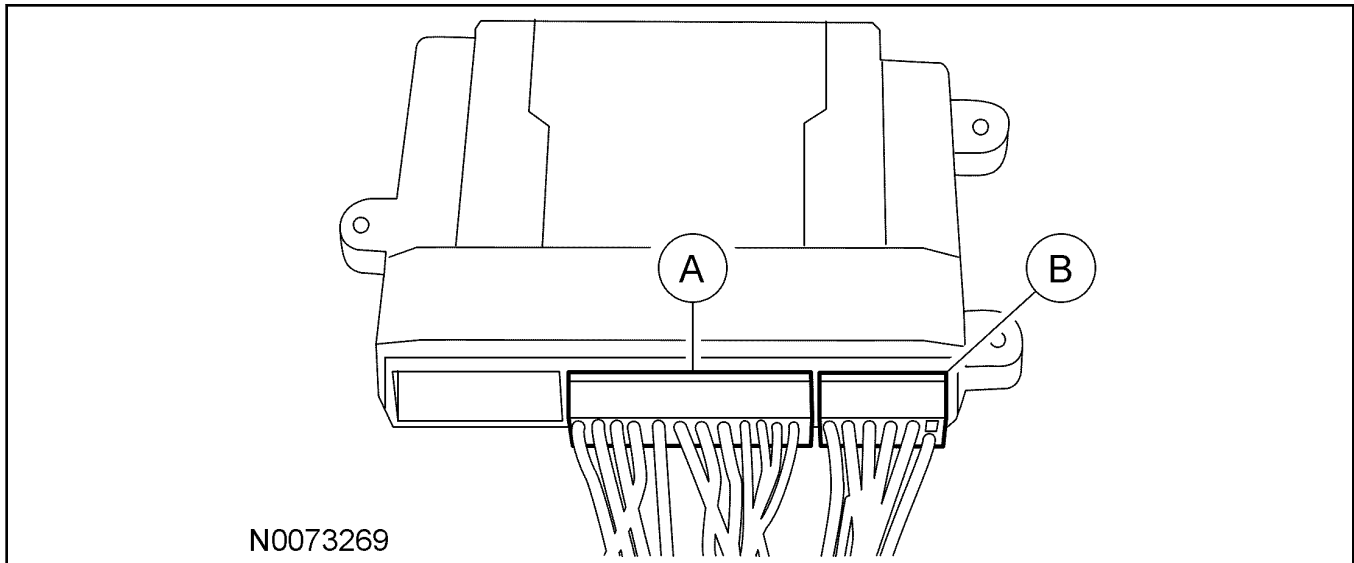
**INSTALLATION (Continued)****7. NOTE:**

Do not cut the override programming button off of the harness, it is used for all installations.

**NOTE:**

[For vehicle specific wiring diagram\(s\) click here.](#)

Referring to the vehicle specific wiring section for the system being installed, gather all individual wires that will be routed to the same areas of the vehicle into groups. Cover each wire group with electrical tape for approximately 18". Depending on the vehicle, there will be 2 to 5 different wire groups.

Trim the unused wires approximately 6 - 8" from the module.

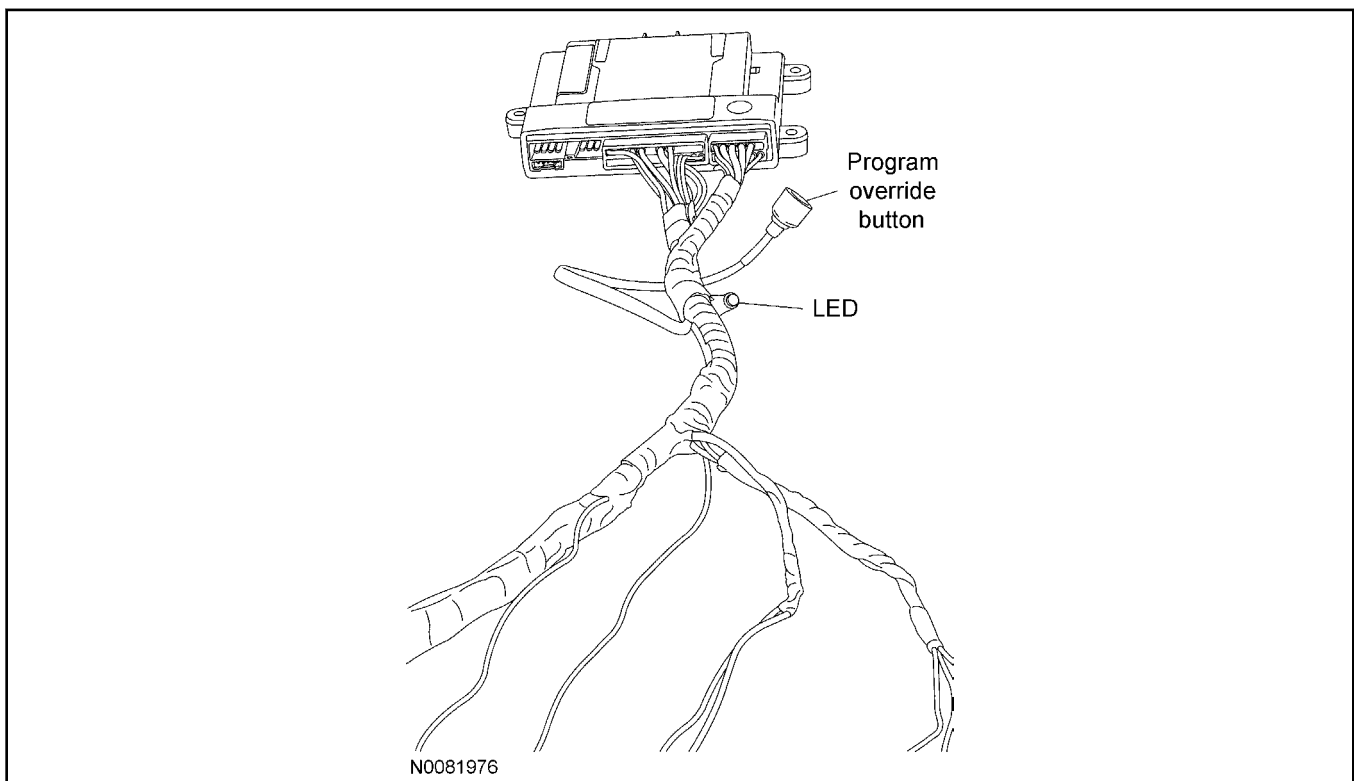

**INSTALLATION (Continued)**

8. Tape the harness sections together, making sure to cover all of the unused wires.

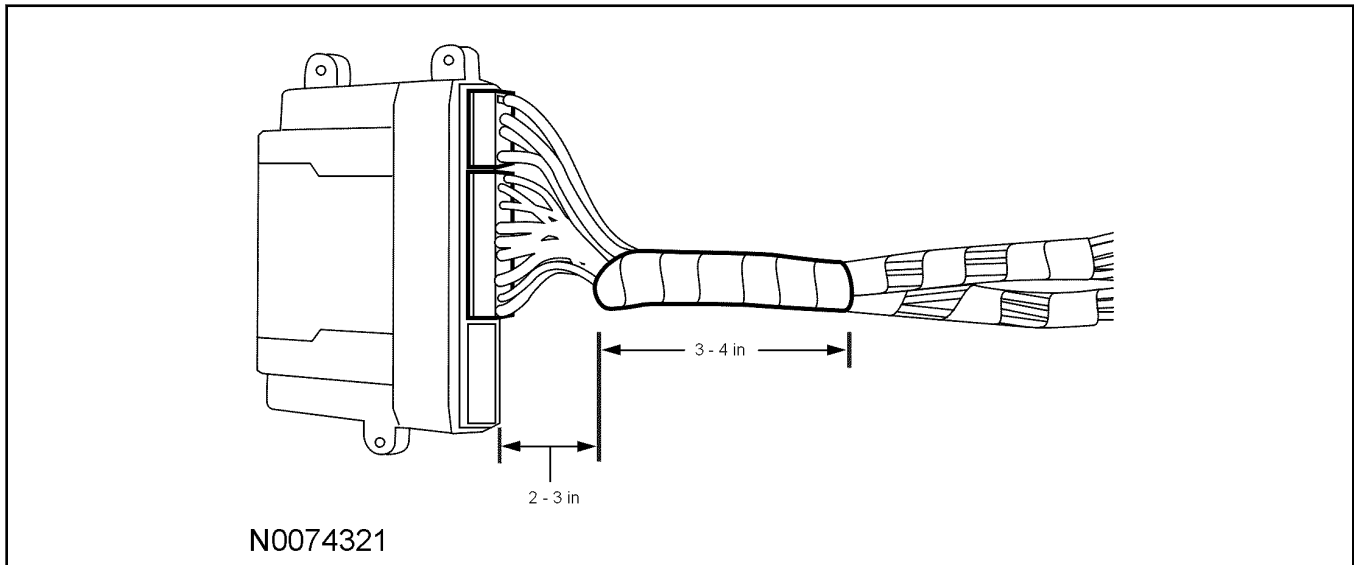
**Vehicle Preparation - All Vehicles**

9. Remove the retainers and the upper and lower steering column shrouds.
10. Open and remove the glove box.
11. Remove the RH lower Instrument panel insulator.

**Antenna Mounting****NOTE:**

For good range of operation, the antenna must be installed correctly.

**NOTE:**

Keep these points in mind when selecting a location and mounting the antenna.

- Do not mount the antenna behind or on any metal film or window tinting on the windshield.
- Do not mount the antenna so that one of the antenna elements touches or crosses any vehicle wiring and/or metal.
- On vehicles without metal film in the windshield around the rear view mirror, mount the antenna between the headliner and the rear view mirror.
- On vehicles equipped with an electronic mirror, or on vehicles with metal film around the rearview mirror, mount the antenna approximately 3 inches below the mirror attachment point to the windshield and/or mirror electronics.

12. Choose a suitable mounting location based on the guidelines above.

**INSTALLATION (Continued)****Install The Antenna**

13. Clean the mounting surface using an alcohol base solution and a clean cloth.

**14. NOTE:**

Do not touch the adhesive, reduced adhesion may result.

**NOTE:**

Make sure that the long wire on the antenna is pointing towards the top of the windshield since this wire will be routed along the headliner.

**NOTE:**

The wire will be attached to the control module later in this procedure.

Remove the protective backing from the adhesive on the antenna and firmly press the body of the antenna to the windshield.

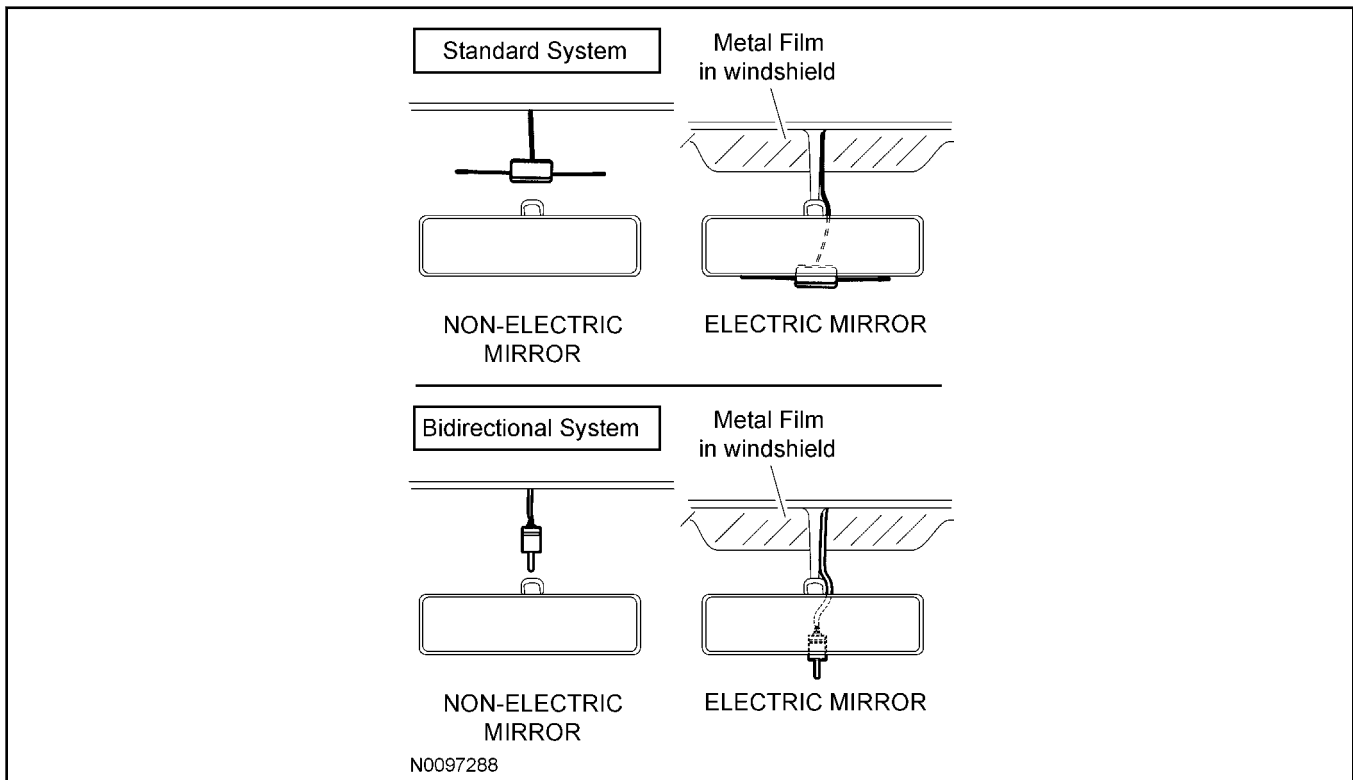

15. If necessary, position the A pillar trim slightly outward to provide access to route the antenna wire.

**NOTE:**

Do not route the antenna wire over the top of the air bag.

16. Route the antenna cable along the headliner and down the A pillar towards the floor.

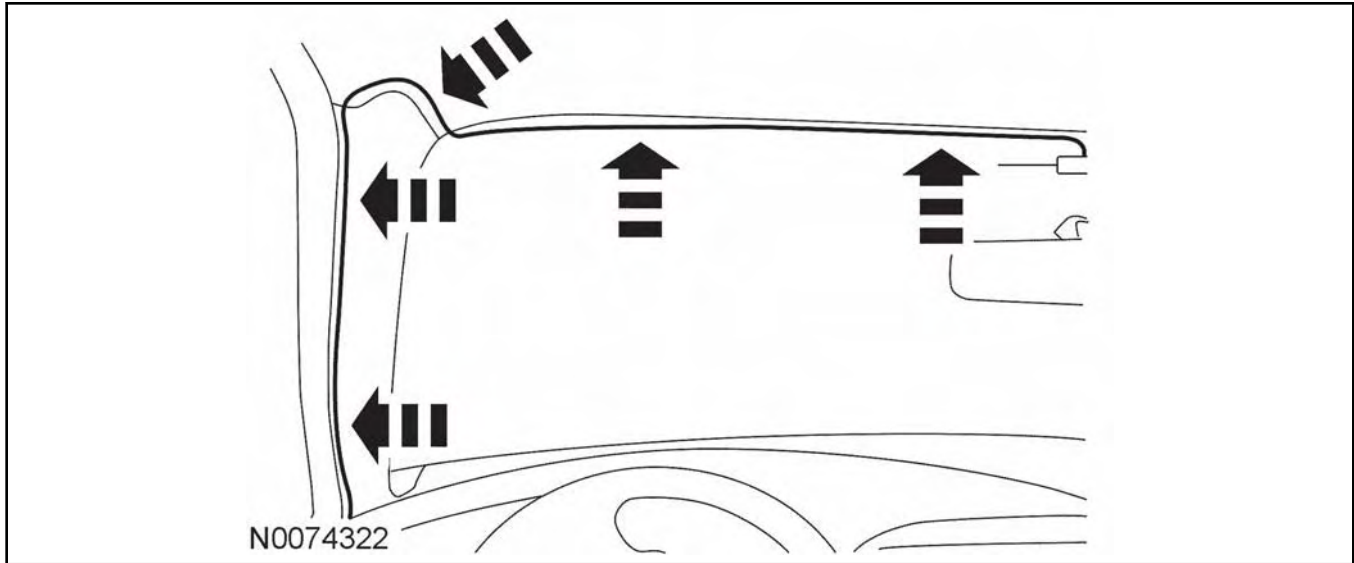
**INSTALLATION (Continued)**

17. Reposition the A pillar trim panel.

**Install the Remote Start Control Module and Harness Assembly**

18. Place the remote start module and harness assembly on the floor of the vehicle.

**Install the DNA-9 Relay Harness and Module**

19. Disconnect the Passive Anti-Theft System (PATS) transceiver electrical connector.
20. Connect the DNA-9 relay harness to the PATS transceiver electrical connector and to the vehicle harness.
21. Connect the DNA-9 relay harness to the remote start module.

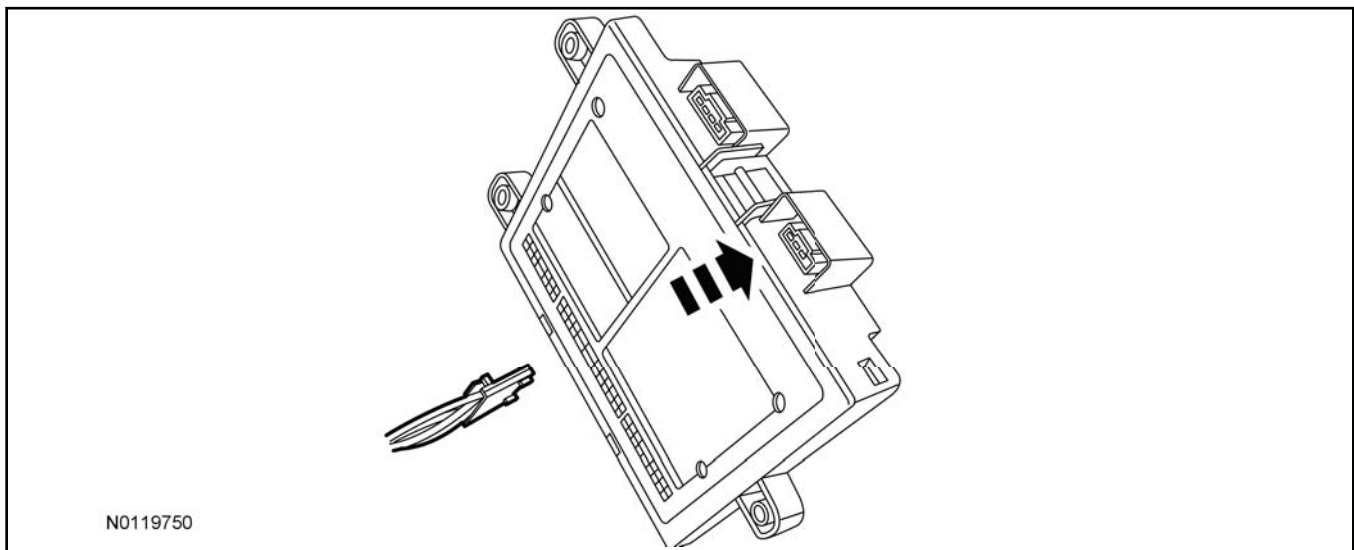

22. Connect the DNA-9 Module to the relay harness.
- Secure to the right of the steering column with tie-straps.

**INSTALLATION (Continued)**

23. Connect the DNA-9 relay harness to the 2-pin connector on the remote start module harness.

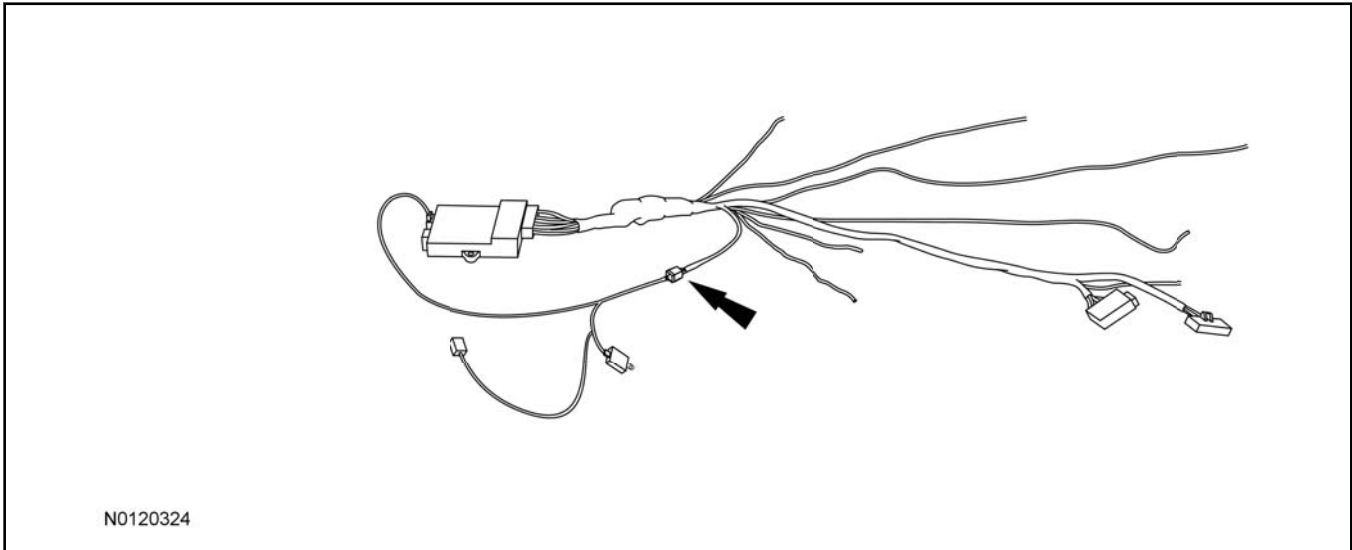
**Identify Circuit Wires For Connections****NOTE:**

For vehicle specific wiring diagram(s) [click here](#).

**NOTE:**

For proper wire splicing techniques [click here](#).

24. Connect the Black ground wire from the remote start module harness to the chassis ground point on the drivers side.

- Chassis ground points are located near the drivers side sill plate.

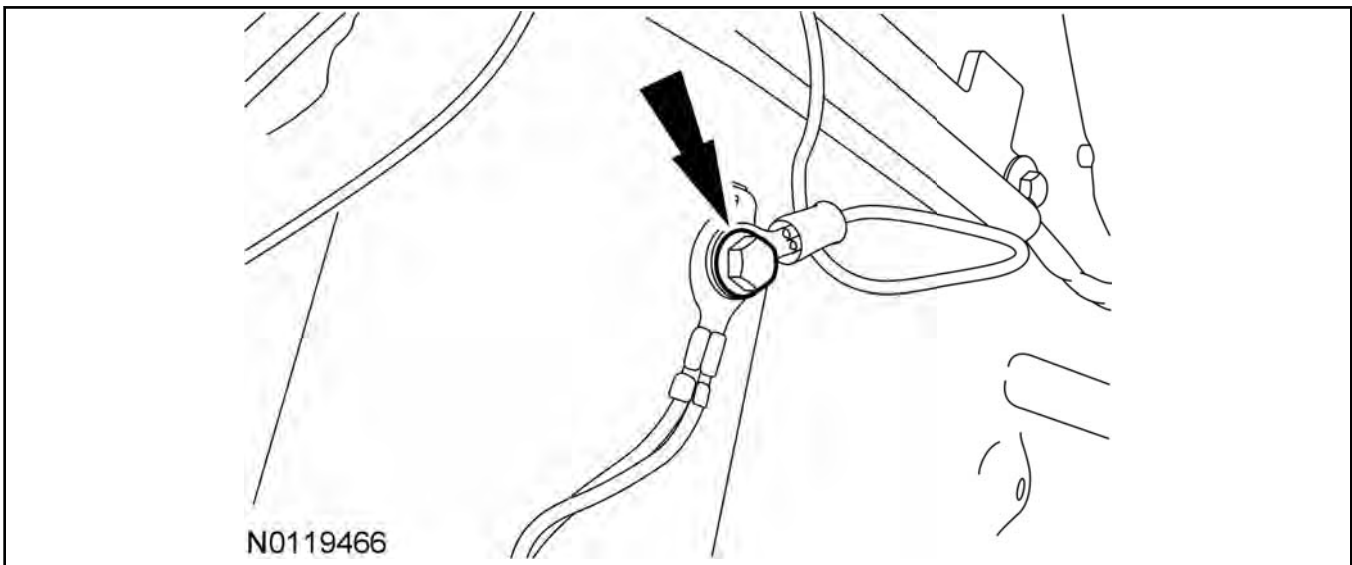

25. Disconnect the ignition switch electrical connector.

26. Connect the remote start harness hard shell connectors to the ignition switch and ignition switch connector.

**INSTALLATION (Continued)****27. NOTE:**

A DVOM connected to the correct wire will show 12V, then show 0V when the horn button is held. A logic probe will show power on the correct wire, then show ground when the horn button is held. Identify the Brown horn circuit wire in the steering column harness.

28. Connect the Brown/Black wire from the remote start module harness to the Brown horn circuit wire in the steering column harness.

**29. NOTE:**

This circuit should be tested with ignition OFF.

**NOTE:**

A DVOM connected to the correct wire will show open, then show 0V when the door lock switch is pressed.

A logic probe will show open on the correct wire, then show ground when the door lock switch is pressed.

Identify the Yellow/Gray power door lock circuit wire at the Body Control Module (BCM) connector C2280G pin 6.

30. Connect the Blue wire from the remote start module harness to the Yellow/Gray power door lock circuit wire at the Body Control Module (BCM) connector C2280G pin 6.

**31. NOTE:**

A DVOM connected to the correct wire will show 0V, then show 12V while depressing the brake pedal.

A logic probe will show ground on the correct wire, then show power while depressing the brake pedal.

Identify the Blue/Gray brake switch circuit wire at the brake switch.

32. Connect the Brown wire from the remote start module harness to the Blue/Gray brake switch circuit wire at the brake switch harness.

**33. NOTE:**

A DVOM connected to the correct wire will show 0V with the vehicle door(s) open and the dome light ON, then show 12V with the vehicle door(s) closed and the dome light OFF.

**NOTE:**

A logic probe connected to the correct wire will show power with the vehicle door(s) open and the dome light ON, then show ground with the vehicle door(s) closed and the dome light OFF.

**NOTE:**

Be sure that the dome light has timed out and is OFF before performing the door closed test. Be sure that the dome lamp is illuminated before performing the door open test.

Identify the Yellow/Gray dome light circuit wire at the Body Control Module (BCM) connector C2280C pin 5.

34. Connect the Green/Violet wire from the remote start module harness to the Yellow/Gray dome light circuit wire at the Body Control Module (BCM) connector C2280C pin 5.

**35. NOTE:**

A DVOM connected to the correct wire will show 0V with the head lamps switch in the OFF position, then show 12V with the head lamp switch in the parking lights ON position.



**INSTALLATION (Continued)****NOTE:**

A logic probe will show ground with the head lamp switch in the ON position and OPEN with the switch in the OFF position.

Identify the Yellow/Blue parking lights circuit wire at the headlamp switch.

36. Connect the White wire from the remote start module harness to the Violet/White parking lights circuit wire at the headlamp switch.

**Install The Hood Safety Switch****37. NOTE:**

Route the hood safety switch wire carefully avoiding any moving parts or components that can produce excessive heat.

**NOTE:**

Using a piece of convolute adds in the appearance of the installation.

**NOTE:**

The switch should be positioned about 30 degrees below parallel to the ground to accommodate for parking on inclines.

Failure to position the switch properly could result in one of the following:

- False alarm trips
- Non-Remote Start events
- Inadvertent shutdown during Remote Start

Locate an easy to access area to the left of the driver side hood hinge and install the hood safety switch using the supplied metal screws.

38. Apply rustproofing compound (PM-13-A) to the drilled hole and torque the screw to 1.00 Nm (10 lb-in).

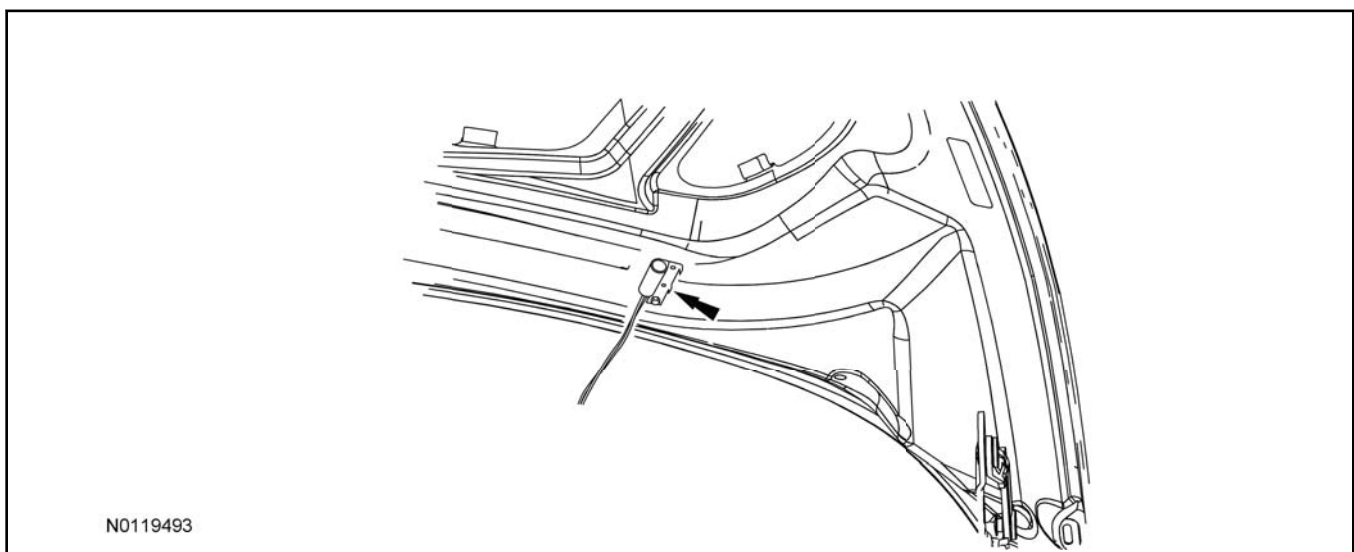

39. Connect hood switch ground wire to a suitable location on the bulkhead.

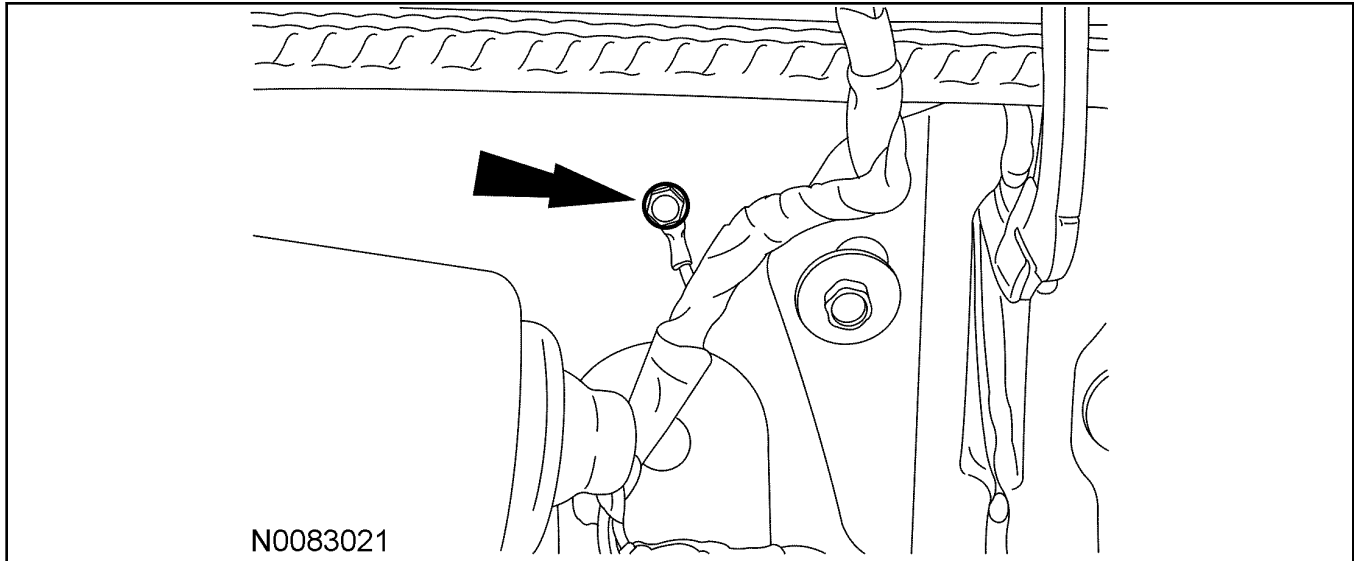
**INSTALLATION (Continued)****40. NOTE:**

Place the label on the radiator fan shroud or similar area.

Install the underhood warning label

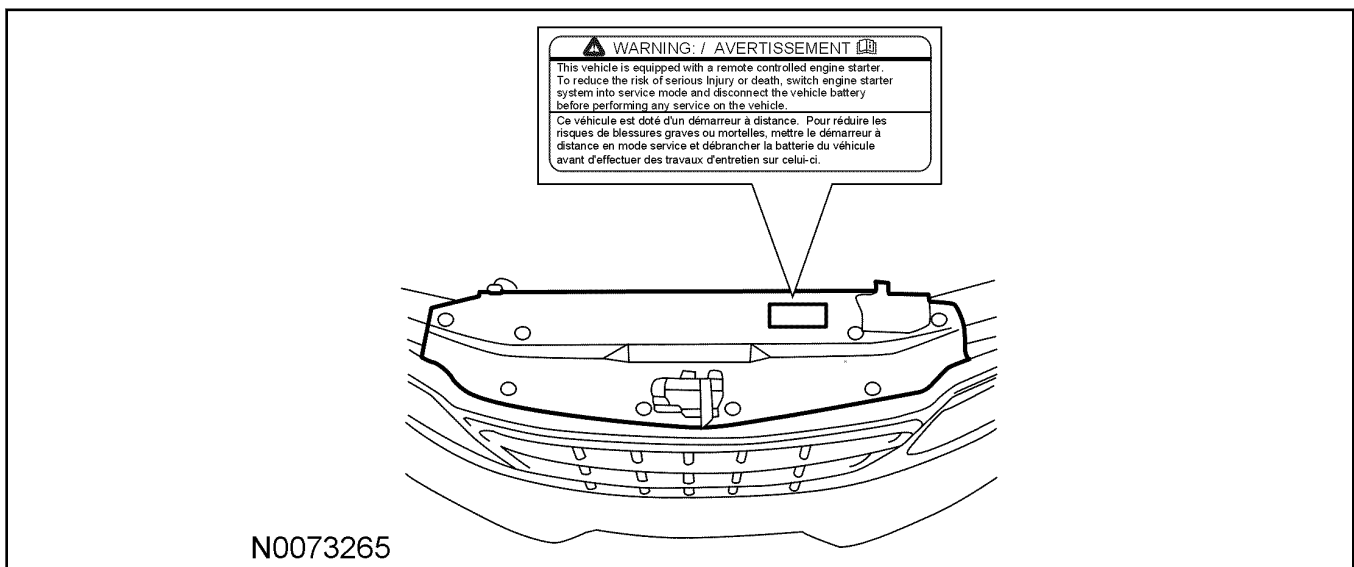

41. Route the Gray hood safety switch wire through the bulkhead into the engine compartment and attach to the hood safety switch.

42. Connect the antenna to the RMST control module.

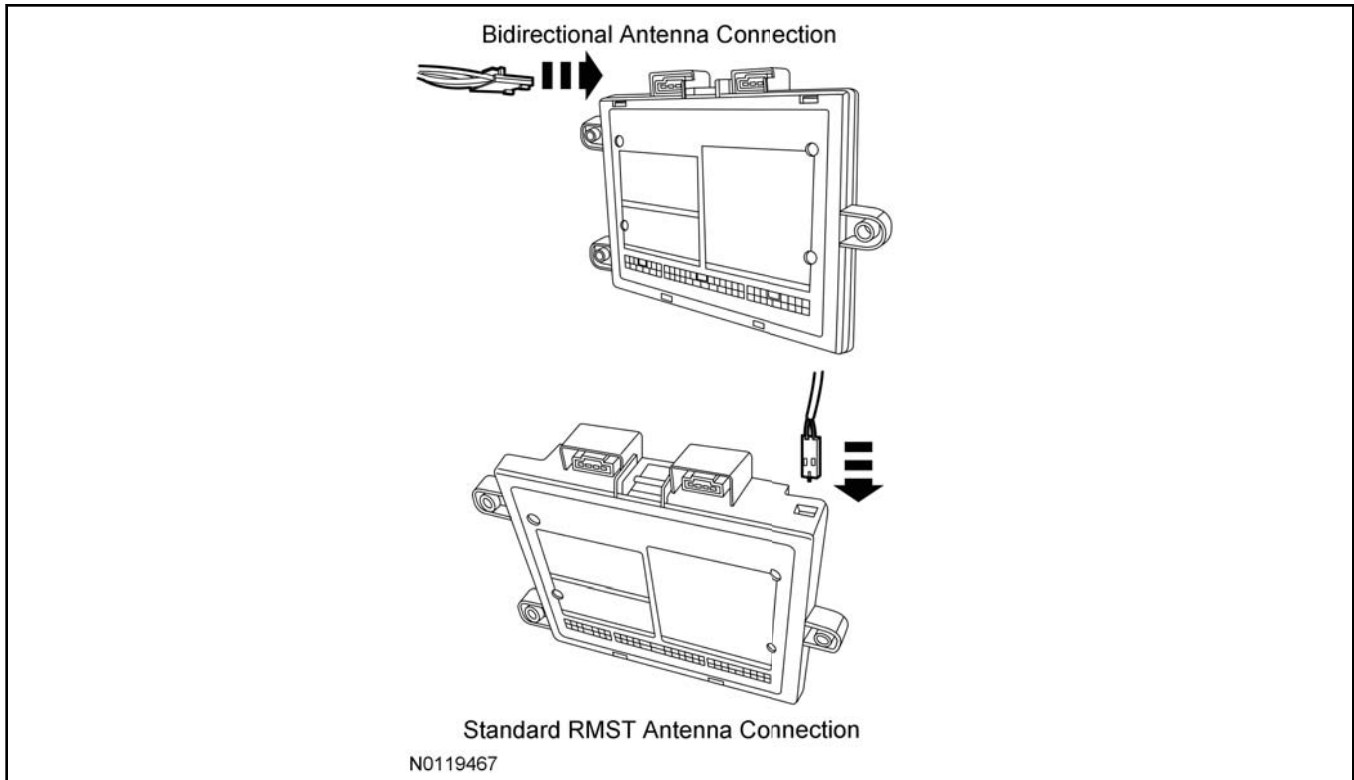
**INSTALLATION (Continued)****Program The RMST System**

43. Refer to the RMST programming section for this vehicle [click here](#).

**Secure RMST Harness and Control Module**

44. Use the supplied tie wraps to secure the RMST harness wires.

**45. NOTE:**

Do not mount the control module in the knee bolster area.  
Secure the control module at three points to the vehicle.

Use the supplied long tie wraps to mount the RMST control module to the underdash wiring harness, to the right of the steering column.

**All Vehicles**

46. Install the upper and lower steering column shrouds.  
Install the retainers.

47. Install the glove compartment.

48. Install the RH lower Instrument panel Insulator.

## GENERAL PROCEDURES

### Programming - Standard Remote Start

#### Programming the Module

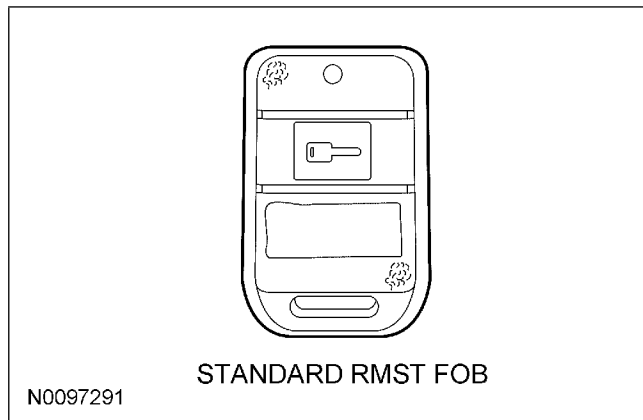

1. NOTE : If the remote start options (Key-in sense polarity, door ajar polarity, or tach mode) are not programmed correctly, vehicle will not remote start or operate properly.

NOTE : Make sure that the hood and doors are closed before proceeding .

NOTE : The LED on the remote start harness must be visible to complete module programming .

NOTE : The remote start override button must be accessible.

#### Programming Options: Entering Programming Mode

2. See chart below for programming information.

##### Program Bank 2 Chart (5 Honks)

BANK	OPTIONS	DESCR	LED
2	1	TACHLESS MODE	ON

3. Press and hold the brake pedal

4. Turn the ignition key to the RUN position.  
The dome light will turn off.

5. Press and hold the remote start system override button for at least 10 seconds

After 10 seconds the horn will honk 3 times, indicating the system is now in the learn mode

Release the brake pedal and the RMST override button

6. Press and release the over ride button. The horn will honk 4 times indicating the system has entered the first program bank

If not, please check the following:

- Brake pedal switch wire solder connection.
- Hood closed and Grey hood safety switch wire solder connection .
- All doors closed and dome light circuit wire solder connections .
- The key is in the RUN position.
- The software cartridge is firmly seated in the RMST module.
- The RMST harness connections are firmly seated in the RMST module.

NOTE : If you require additional assistance CALL 1-800-FORD KEY.

7. Press and release the over ride button again. The horn will honk 5 times indicating the system has entered the second program bank

8. Press and release the brake pedal  
The horn will honk 1 time indicating the system has entered the option 1 of the second program bank

NOTICE : When turning LED on or off using remote start fob button quickly press and immediately release the remote start button .

Failure to quickly release the remote start fob button will result in system defaulting to the factory options.

9. The LED must be on for option 1. If the LED is illuminated no action is required. If the LED is not illuminated press the remote start fob button and verify the LED illuminates.

## GENERAL PROCEDURES (Continued)

NOTE: If the remote start fob button is held for more than 3 seconds the system will chirp the horn 4 times, indicating the system has returned to factory default settings. If this occurs return to step 1 of the programming section and reprogram the remote start module.

NOTE: The remote start module is now programmed.

10. Remove the ignition key.

### Programming the DNA-9

NOTE: Two PATS keys are required to program the DNA-9.

NOTE: IMPORTANT: Each of the following steps should be completed with no more than 5 seconds delay between steps.

11. Insert the first ignition key and turn to the run position.

Watch for the PATS light to turn off. Remove the first key.

12. Insert the second ignition key and turn to the run position.

Watch for the PATS light to turn off. Remove the second key.

13. Press and hold the remote start button



for 3 seconds.  
The PATS light should stay on for 3-5 seconds before turning off, which means that the DNA-9 was successfully programmed.

NOTE: If the PATS light blinks rapidly, repeat steps 1-3 to retry programming the DNA-9.

NOTE: The engine will start if the Remote Start kit has been installed correctly, the brake is not depressed, and the hood and doors are closed.

## GENERAL PROCEDURES

### Functional Test - Standard Remote Start

NOTE: If during any of the steps of the functional test, the remote start system or vehicle doesn't react or perform accordingly, please refer to the remote start troubleshooting guide.

NOTE: [For remote start troubleshooting guide click here.](#)

1. Make sure all doors are closed but hood is open and windows are down (doors will be locking).
2. Press and hold the Start button on the remote control key fob for 2-3 seconds - Horn should honk once indicating receipt of the start request.
3. The remote start systems should turn on the ignition, but then honk the horn twice and shut down indicating the hood is open.
4. Close the hood, and insert a key into the ignition switch.
5. Attempt to re-start the vehicle again using the key fob.
6. The remote start systems should turn on the ignition, but then honk the horn five times and shut down indicating a key is in the ignition switch.
7. Remove the key and open a door.
8. Attempt to re-start the vehicle again using the key fob.
9. The remote start systems should turn on the ignition, but then honk the horn three times and shut down indicating a door is open.
10. Close the door.
11. Attempt to re-start the vehicle again using the key fob.

12. Once the vehicle starts, verify that all heat and A/C functions operate normally and that the doors have locked.
13. On vehicles equipped with power window interrupt, Attempt to close windows to check power window interrupt function.
14. Once all systems have been checked, open the door\*, or press the brake pedal - the remote start systems should shut down.

### Troubleshooting

15. NOTE: When attempting to remote start your vehicle, the system has several safety checks that it performs. If any of these inputs are present that should not be, the system will respond back to you with several horn "chirps" to help you identify which input is present. These "chirps" will occur after initiating a start sequence with the transmitter, the system will turn on the ignition, but then respond back with several horn "chirps" and abort the starting process.

Example: Depress the remote start fob button for 3 seconds and then release. The vehicle horn will "chirp" one time to indicate that RMST signal was received. If the vehicle doesn't start and the horn "chirps" 3 times, there is a fault - "Vehicle Door is Open"

CHIRPS	PROBLEM
1 Chirp	DNA-9 not programmed correctly, or the DNA-9 antenna ring is damaged.
2 Chirps	BRAKE is being pressed, or the HOOD is open.
3 Chirps	One of the vehicles DOORS are open.
4 Chirps	TACH not programmed.

**GENERAL PROCEDURES (Continued)**

CHIRPS	PROBLEM
5 Chirps	The KEY is in the ignition.
6 Chirps	The remote start system is in SERVICE/VALET mode

## GENERAL PROCEDURES

### Programming - Bidirectional Remote Start

#### Programming the Module

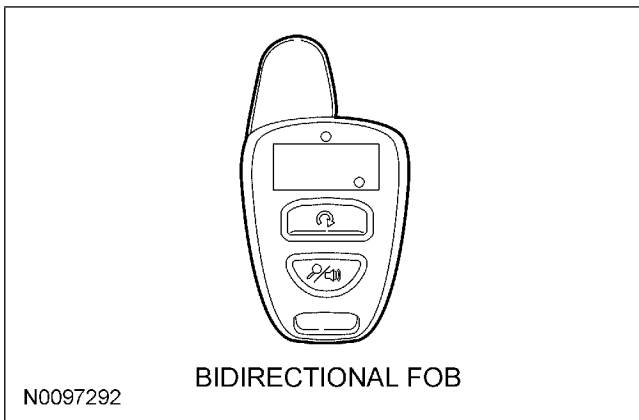

- NOTE : If the remote start options (Key-in sense polarity, door ajar polarity, or tach mode) are not programmed correctly, vehicle will not remote start or operate properly

NOTE : Make sure that the hood and doors are closed before proceeding.

NOTE : The LED on the remote start harness must be visible to complete module programming.

NOTE : The remote start override button must be accessible.

#### Programming Options: Entering Programming Mode

- See chart below for programming information.

#### Program Bank 2 Chart (5 Honks)

BANK	OPTIONS	DESCR	LED
2	1	TACHLESS MODE	ON

- Press and hold the brake pedal
- Turn the ignition key to the RUN position.  
The dome light will turn off.

- Press and hold the remote start system override button for at least 10 seconds

After 10 seconds the horn will honk 3 times, indicating the system is now in the learn mode

Release the brake pedal and the RMST override button

- Press and release the override button. The horn will honk 4 times indicating the system has entered the first program bank

If not, please check the following:

- Brake pedal switch wire solder connection.
- Hood closed and Grey hood safety switch wire solder connection.
- All doors closed and dome light circuit wire solder connections.
- The key is in the RUN position.
- The software cartridge is firmly seated in the RMST module.
- The RMST harness connections are firmly seated in the RMST module.

NOTE : If you require additional assistance CALL: 1-800-FORD KEY.

- Press and release the override button again. The horn will honk 5 times indicating the system has entered the second program bank.
- Press and release the brake pedal  
The horn will honk 1 time indicating the system has entered the option 1 of the second program bank.

NOTICE : When turning LED on or off using remote start fob button quickly press and immediately release the remote start button.

Failure to quickly release the remote start fob button will result in system defaulting to the factory options.

- The LED must be on for option 1. If the LED is illuminated no action is required. If the LED is not illuminated press the remote start fob button and verify the LED illuminates.



**GENERAL PROCEDURES (Continued)**

NOTE: If the remote start fob button is held for more than 3 seconds the system will chirp the horn 4 times, indicating the system has returned to factory default settings. If this occurs return to step 1 of the programming section and reprogram the remote start module.

NOTE: The remote start module is now programmed.

10. Remove the ignition key.

**Programming the DNA-9**

NOTE: Two PATS keys are required to program the DNA-9.

NOTE: IMPORTANT: Each of the following steps should be completed with no more than 5 seconds delay between steps.

11. Insert the first ignition key and turn to the run position.

Watch for the PATS light to turn off. Remove the first key.

12. Insert the second ignition key and turn to the run position.

Watch for the PATS light to turn off. Remove the second key.

13. Press the remote start button  twice within 3 seconds.

The PATS light should stay on for 3-5 seconds before turning off, which means that the DNA-9 was successfully programmed.

NOTE: If the PATS light blinks rapidly, repeat steps 1-3 to retry programming the DNA-9.

NOTE: The engine will start if the Remote Start kit has been installed correctly, the brake is not depressed, and the hood and doors are closed.

# GENERAL PROCEDURES

## Functional Test - Bidirectional Remote Start

NOTE: If during any of the steps of the functional test, the remote start system or vehicle doesn't react or perform accordingly, please refer to the remote start troubleshooting guide.

NOTE: [For remote start troubleshooting guide click here.](#)

1. Make sure all doors are closed but hood is open and windows are down (doors will be locking).
2. Press the Start button on the remote control key fob twice within 3 seconds - Horn should honk once indicating receipt of the start request.
3. The remote start systems should turn on the ignition, but then honk the horn twice and shut down indicating the hood is open.
4. Close the hood, and insert a key into the ignition switch.
5. Attempt to re-start the vehicle again using the key fob.
6. The remote start systems should turn on the ignition, but then honk the horn five times and shut down indicating a key is in the ignition switch.
7. Remove the key and open a door.
8. Attempt to re-start the vehicle again using the key fob.
9. The remote start systems should turn on the ignition, but then honk the horn three times and shut down indicating a door is open.
10. Close the door.
11. Attempt to re-start the vehicle again using the key fob.

12. Once the vehicle starts, verify that all heat and A/C functions operate normally and that the doors have locked.
13. On vehicles equipped with power window interrupt, Attempt to close windows to check power window interrupt function.
14. Once all systems have been checked, open the door\*, or press the brake pedal - the remote start systems should shut down.

## Troubleshooting

15. NOTE: When attempting to remote start your vehicle, the system has several safety checks that it performs. If any of these inputs are present that should not be, the system will respond back to you with several horn "chirps" to help you identify which input is present. These "chirps" will occur after initiating a start sequence with the transmitter, the system will turn on the ignition, but then respond back with several horn "chirps" and abort the starting process.

Example: Depress the remote start fob button for 3 seconds and then release. The vehicle horn will "chirp" one time to indicate that RMST signal was received. If the vehicle doesn't start and the horn "chirps" 3 times, there is a fault - "Vehicle Door is Open"

CHIRPS	PROBLEM
1 Chirp	DNA-9 not programmed correctly, or the DNA-9 antenna ring is damaged.
2 Chirps	BRAKE is being pressed, or the HOOD is open.
3 Chirps	One of the vehicles DOORS are open.
4 Chirps	TACH not programmed.

# '11 Fiesta - Key Start

## TYPE "A" CUSTOM WIRE HARNESS

### RMST MODULE WIRE HARNESS

#### STEERING COLUMN HARNESS

	Color	Function
A-3	PINK	Ignition Input/Output
A-2	ORANGE	HVAC Output
A-13	VIOLET	Starter Output
B-8	BLACK/WHITE	Key-in-sense Input
A-4	RED	Battery

	Color	Function
A-21	BROWN/BLACK	Horn Relay Output
A-1	WHITE	Parking Light Output

#### DRIVER'S KICK PANEL HARNESS

	Color	Function
A-5	BLACK	Ground
A-24	BLUE	Door Lock Output
B-7	BROWN	Brake Input
A-20	GREEN/VIOLET	Door Ajar Switch Input

#### UNDER HOOD HARNESS

	Color	Function
A-19	GRAY	Hood Open Switch Input

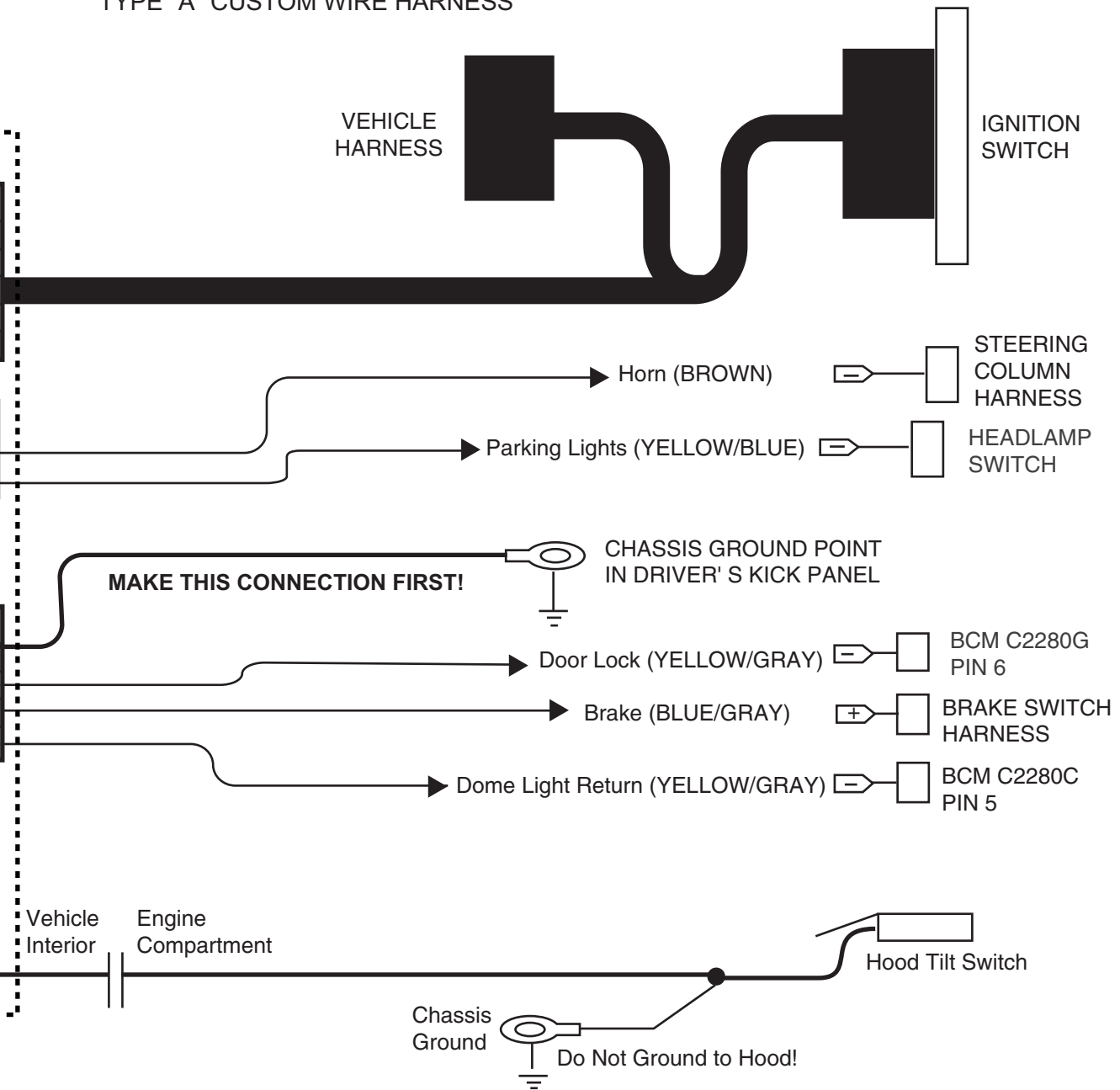

### Body Control Module (BCM)

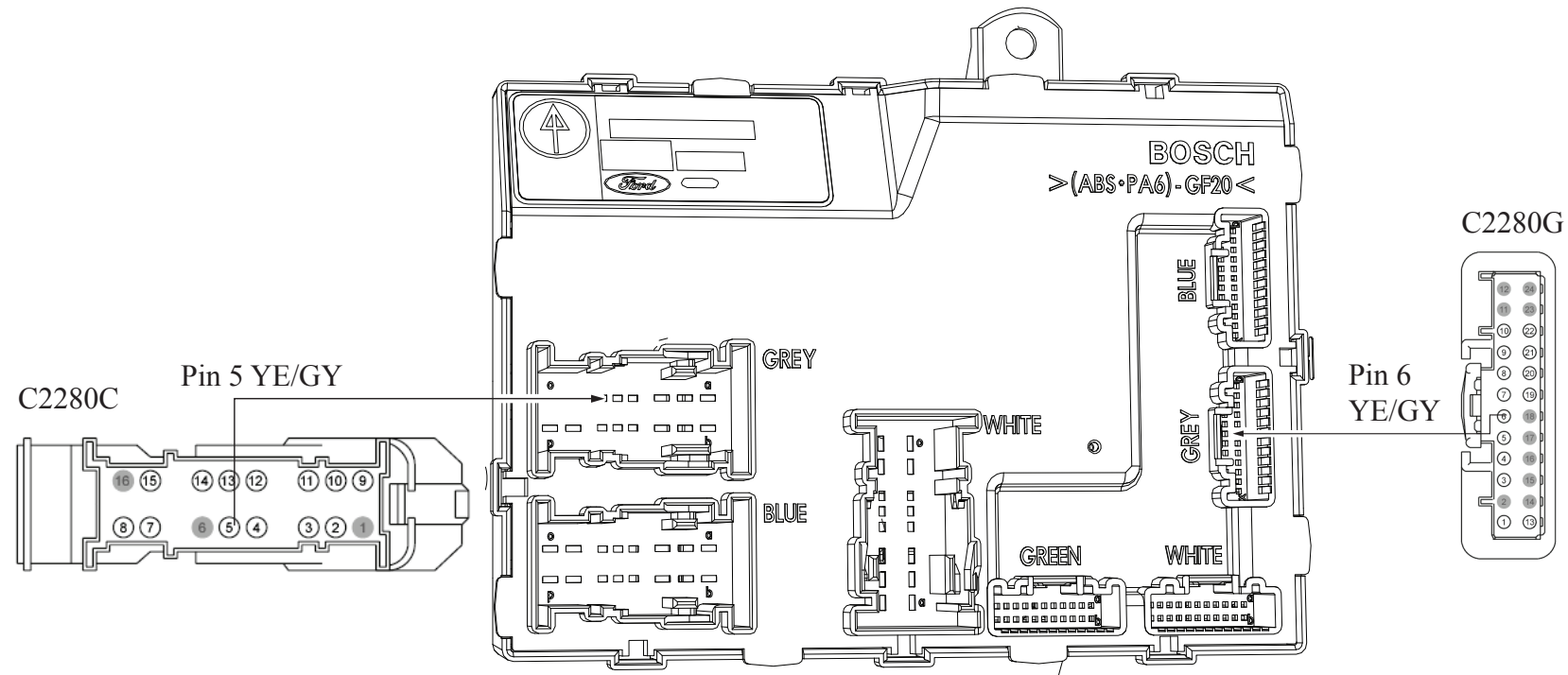

**Manual Table of Contents**

# REMOTE START SYSTEM INSTALLATION

## **CONTENTS**

### **INSTALLATION**

Remote Start

### **GENERAL PROCEDURES**

Proper Splicing Techniques

Programming - Standard Remote Start

Functional Test - Standard Remote Start

Programming - Bidirectional Remote Start

Functional Test - Bidirectional Remote Start

Troubleshooting

### **WIRING DIAGRAMS**

Vehicle Specific Wiring Diagrams

**INSTALLATION**

**Remote Start**

**Remote Start System (RMST) Components**

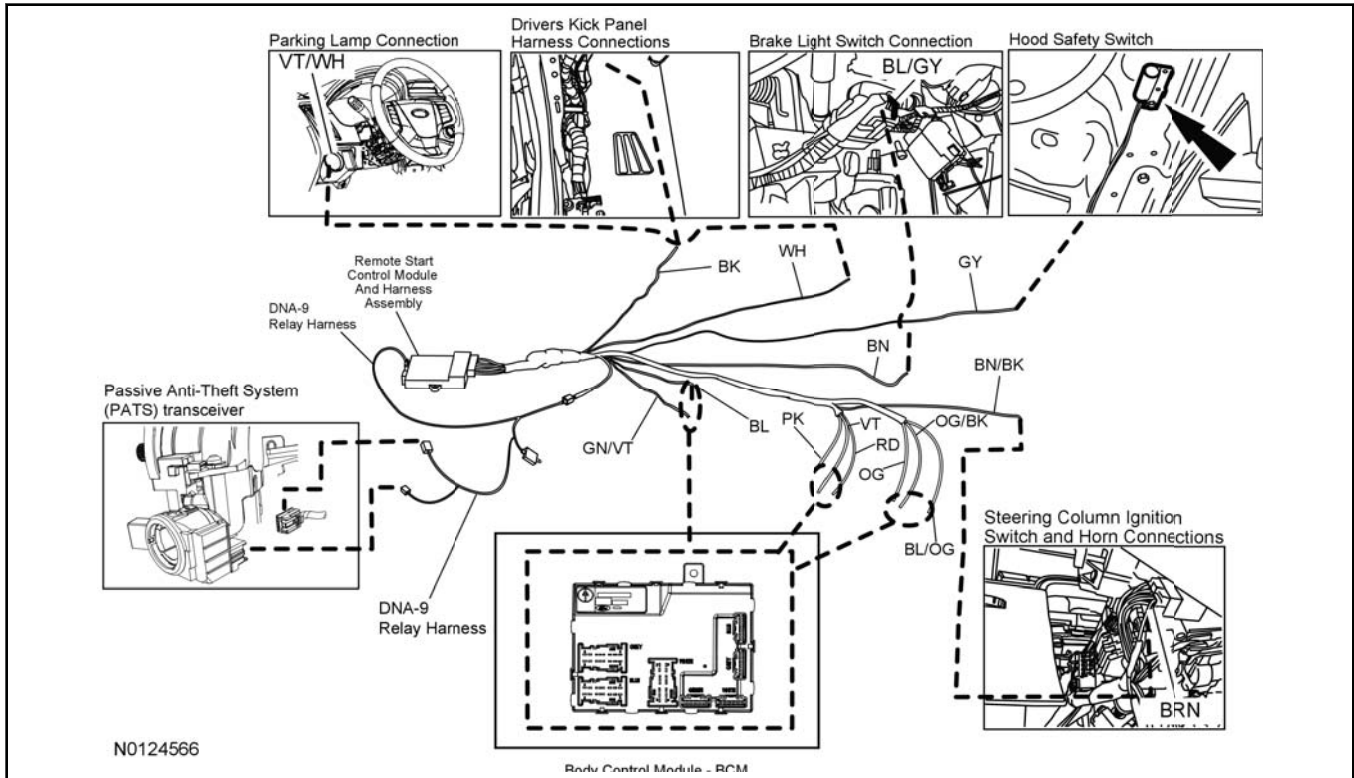

**Fiesta - Push Button Start**

**NOTICE:**

Remote start systems are only applicable to vehicles with automatic transmissions.

1. Verify correct kit number.

**Review Remote Start Installation Kit Contents**

**NOTE:**

Kits are vehicle specific and are not interchangeable.

2. Review the RMST kit contents.

**Remote Start System (RMST) Standard Kit Type - "A"**

QUANTITY	DESCRIPTION
1	TYPE - "A" MODULE ASSEMBLY
1	RMST SOFTWARE CARTRIDGE ASSEMBLY
2	1 BUTTON POWER CODE TRANSMITTER
1	TYPE - "A" CUSTOM WIRING HARNESS

**INSTALLATION (Continued)****Remote Start System (RMST) Standard Kit Type - "A"(Continued)**

1	ANTENNA
1	HOOD SAFETY SWITCH ASSEMBLY
1	INSTALLATION PARTS BAG
1	FUSE PARTS BAG
1	OPERATORS INSTRUCTIONS
1	UNDERHOOD WARNING LABEL
1	DNA-9 MODULE
1	DNA-9 RELAY HARNESS

3. Review the RMST bidirectional kit contents.

**Remote Start System (RMST) Bidirectional Kit Type - "A"**

<b>QUANTITY</b>	<b>DESCRIPTION</b>
1	TYPE - "A" MODULE ASSEMBLY
1	RMST SOFTWARE CARTRIDGE ASSEMBLY
1	2 BUTTON POWER CODE TRANSMITTER
1	TYPE - "A" CUSTOM WIRING HARNESS
1	ANTENNA
1	ANTENNA HARNESS
1	HOOD SAFETY SWITCH ASSEMBLY
1	INSTALLATION PARTS BAG
1	FUSE PARTS BAG
1	OPERATORS INSTRUCTIONS
1	UNDERHOOD WARNING LABEL
1	DNA-9 MODULE
1	DNA-9 RELAY HARNESS
1	REAR-VIEW MIRROR INFORMATION CARD

**Module Preparation**

4. Place the supplied fuses into the power distribution block on the remote start control module.
- Move the polarity jumpers to their proper locations on the control module. Refer to the following illustration.

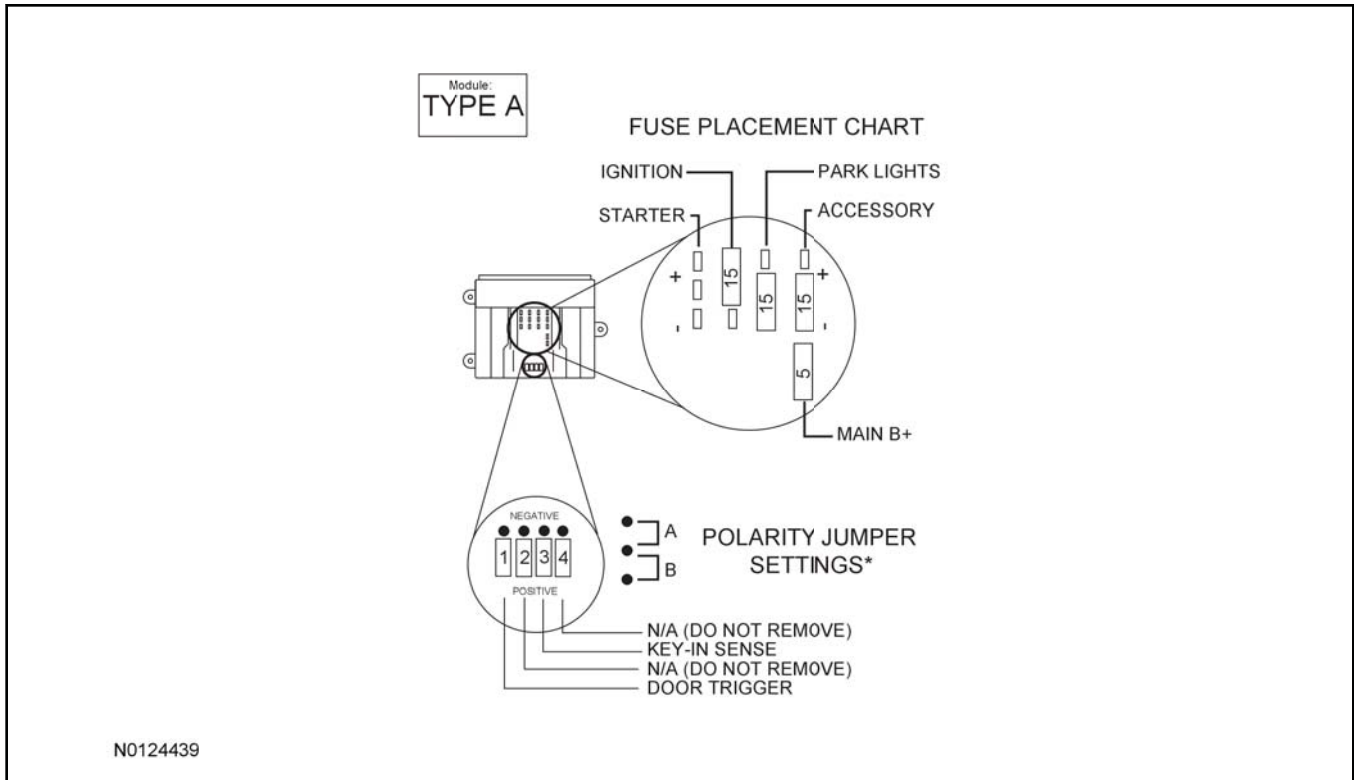

5. Place the software cartridge onto the RMST control module.

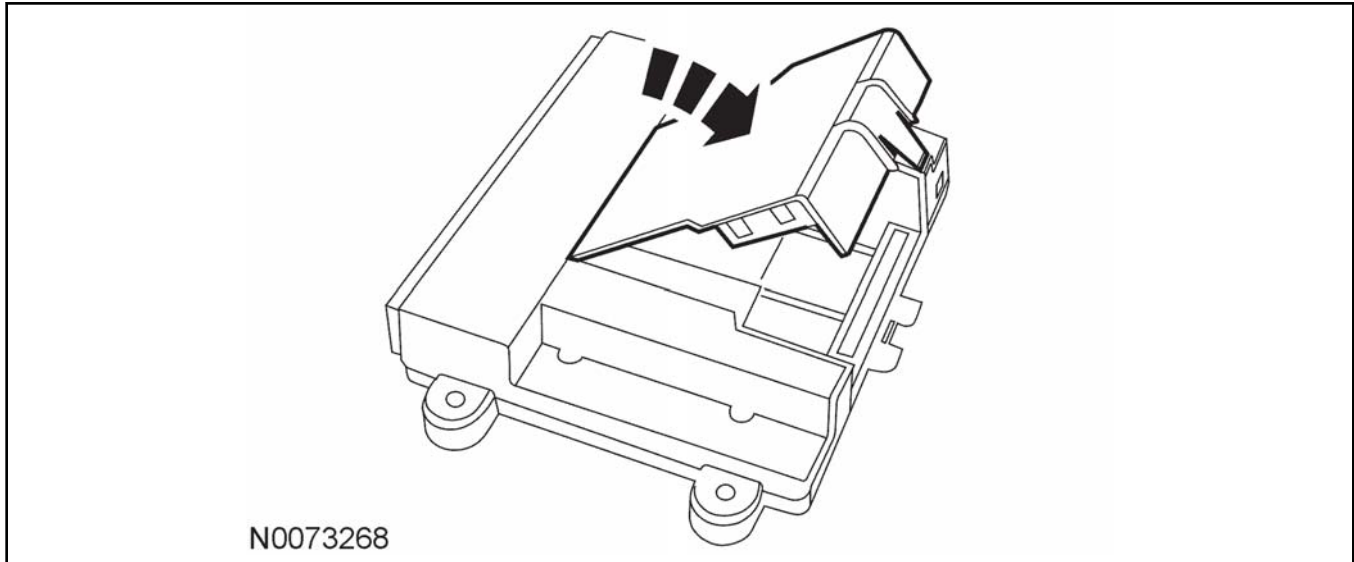

6. Plug the wiring harness(es) into the module.
- A - Harness: 24-way, used on all systems.
  - B - Harness: 10-way, used on all systems with RMST.
  - C - Harness: 16-way, used on all systems with RMST.



**INSTALLATION (Continued)**

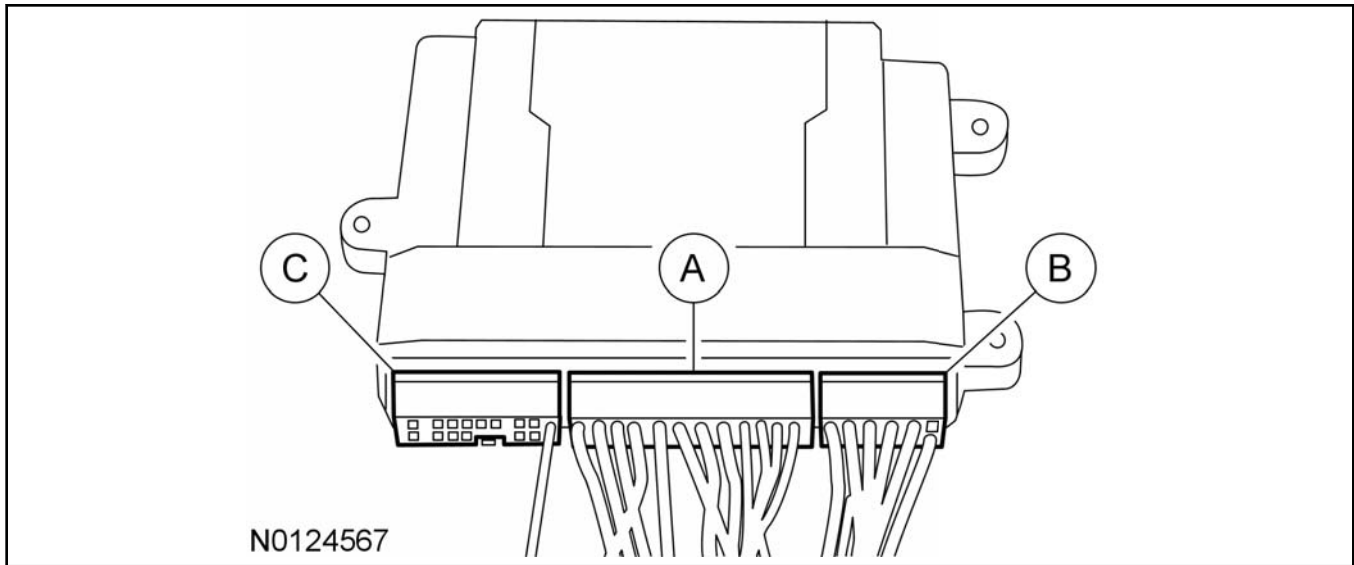

- 7. **NOTE:**  
Do not cut the override programming button from the harness, it is used for all installations.

**NOTE:**  
[For vehicle specific wiring diagram\(s\) click here.](#)

Referring to the vehicle specific wiring section for the system being installed, gather all individual wires that will be routed to the same areas of the vehicle into groups. Cover each wire group with electrical tape for approximately 18". Depending on the vehicle, there will be 2 to 5 different wire groups.

Trim the unused wires approximately 6 - 8" from the module.

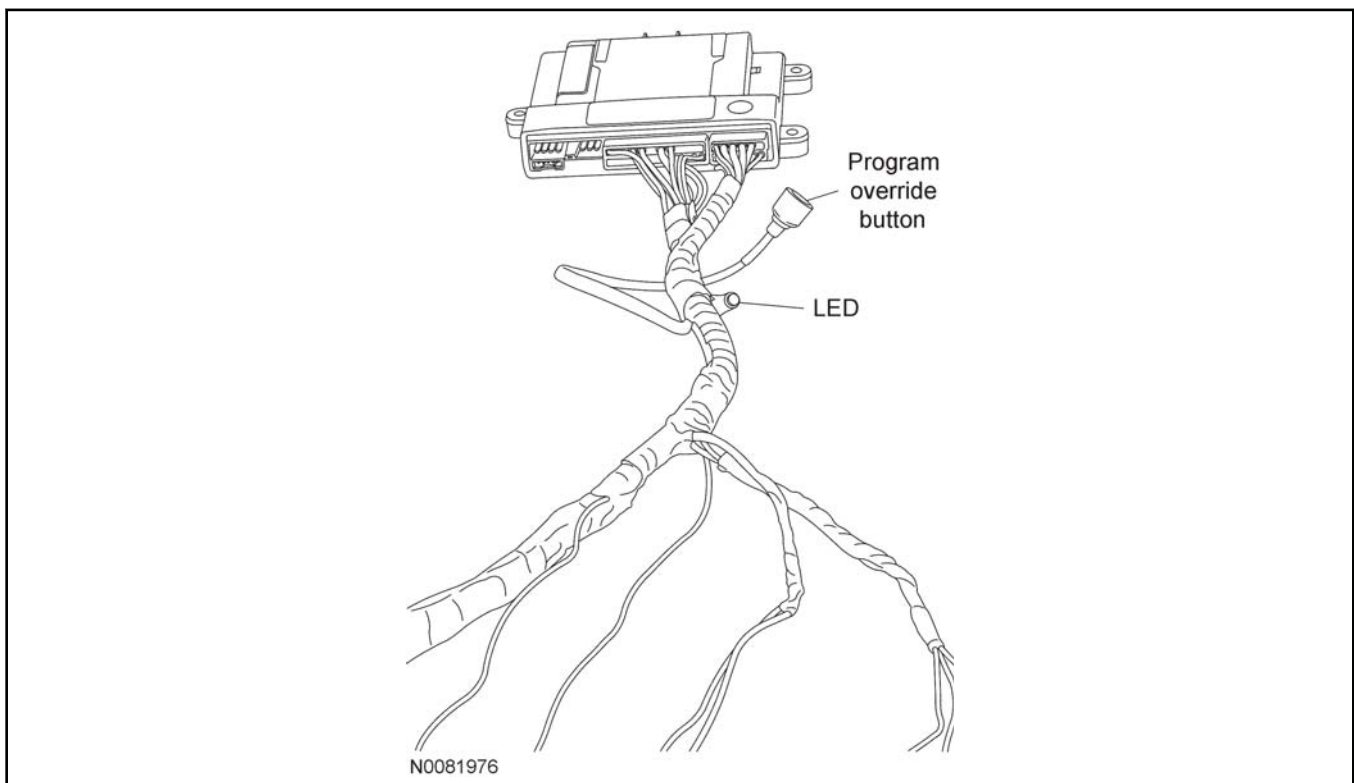

**INSTALLATION (Continued)**

8. Tape the harness sections together, making sure to cover all of the unused wires.

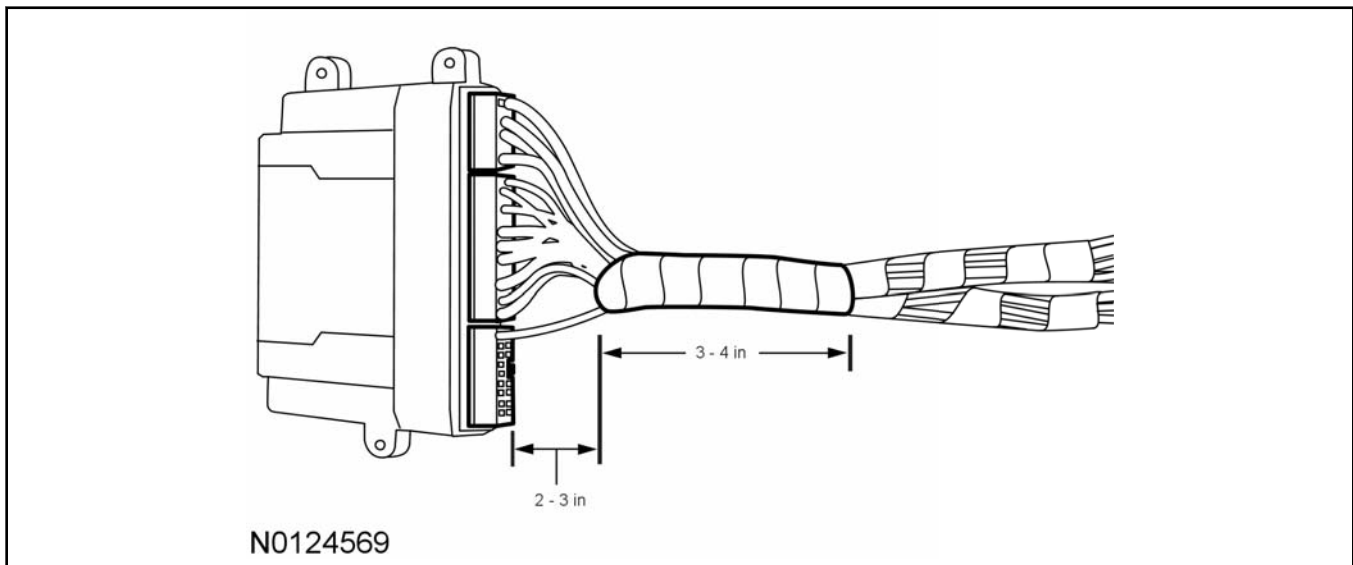
**Vehicle Preparation - All Vehicles**

9. Remove the retainers and the upper and lower steering column shrouds.
10. Open and remove the glove box.
11. Remove the RH lower instrument panel insulator.

**Antenna Mounting****NOTE:**

For good range of operation, the antenna must be installed correctly.

**NOTE:**

Keep these points in mind when selecting a location and mounting the antenna.

- Do not mount the antenna behind or on any metal film or window tinting on the windshield.
- Do not mount the antenna so that one of the antenna elements touches or crosses any vehicle wiring and/or metal.
- On vehicles without metal film in the windshield around the rear view mirror, mount the antenna between the headliner and the rear view mirror.
- On vehicles equipped with an electronic mirror, or on vehicles with metal film around the rearview mirror, mount the antenna approximately 3 inches below the mirror attachment point to the windshield and/or mirror electronics.

12. Choose a suitable mounting location based on the guidelines above.

**Install the Antenna**

13. Clean the mounting surface using an alcohol base solution and a clean cloth.

**INSTALLATION (Continued)****14. NOTE:**

Do not touch the adhesive, reduced adhesion may result.

**NOTE:**

Make sure that the long wire on the antenna is pointing towards the top of the windshield since this wire will be routed along the headliner.

**NOTE:**

The wire will be attached to the control module later in this procedure.

Remove the protective backing from the adhesive on the antenna and firmly press the body of the antenna to the windshield.

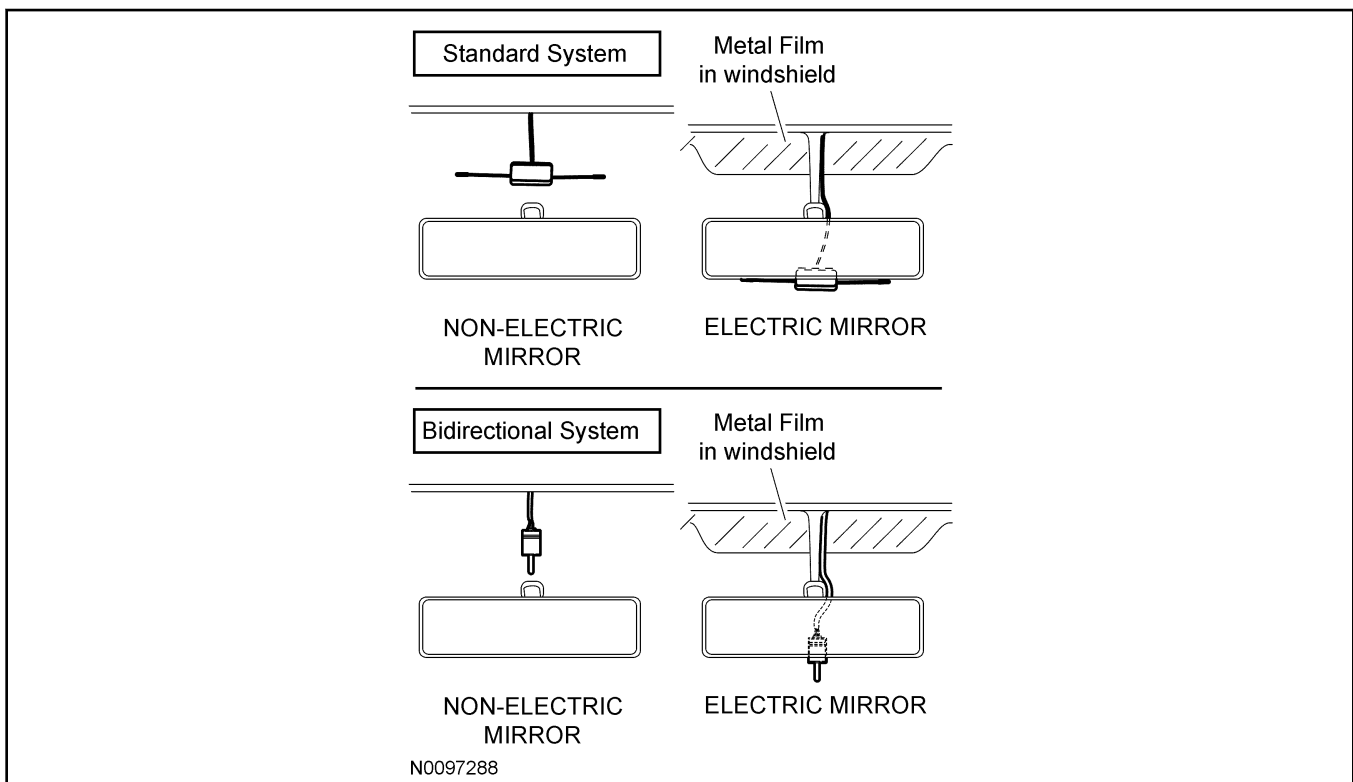

15. If necessary, position the A-pillar trim panel slightly outward to provide access to route the antenna wire.

**NOTE:**

Do not route the antenna wire over the top of the air bag.

16. Route the antenna cable along the headliner and down the A-pillar towards the floor.

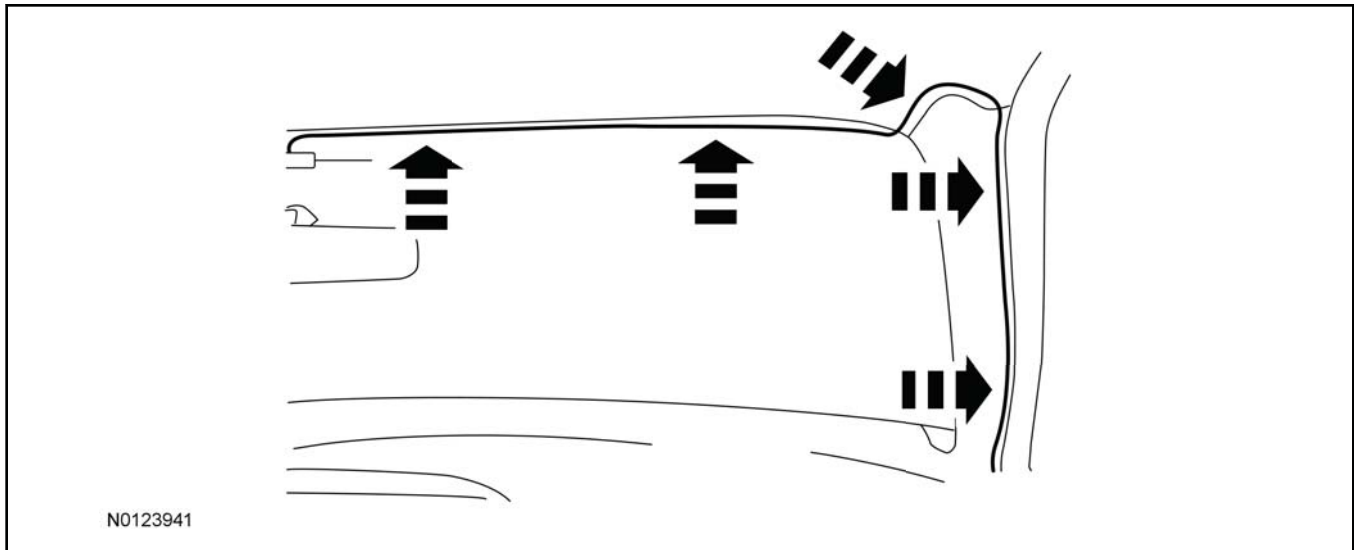
**INSTALLATION (Continued)**

17. Reposition the A-pillar trim panel.

**Install the Remote Start Control Module and Harness Assembly**

18. Place the remote start module and harness assembly on the passenger side floor.

**Install the DNA-9 Relay Harness and Module**

19. Disconnect the passive anti-theft system (PATS) transceiver electrical connector.

20. Connect the DNA-9 relay harness to the PATS transceiver electrical connector and to the vehicle harness.

21. Connect the DNA-9 relay harness to the remote start module.

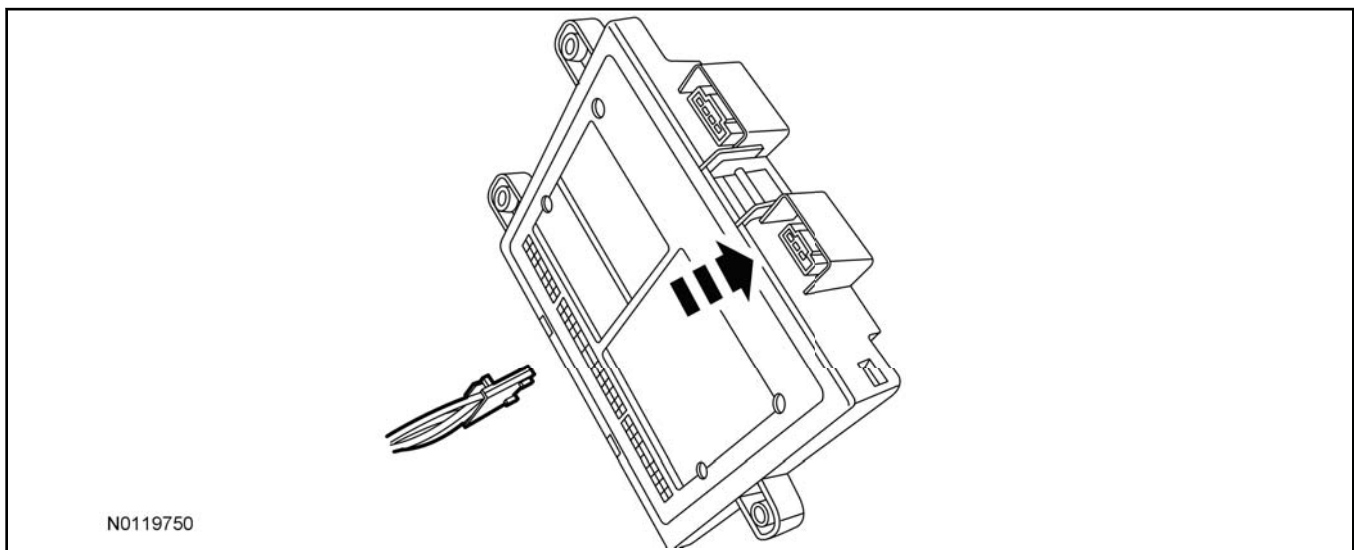

22. Connect the DNA-9 module to the relay harness.

- Secure to the right of the steering column with tie-straps.

23. Connect the DNA-9 relay harness to the 2-pin connector on the remote start module harness.

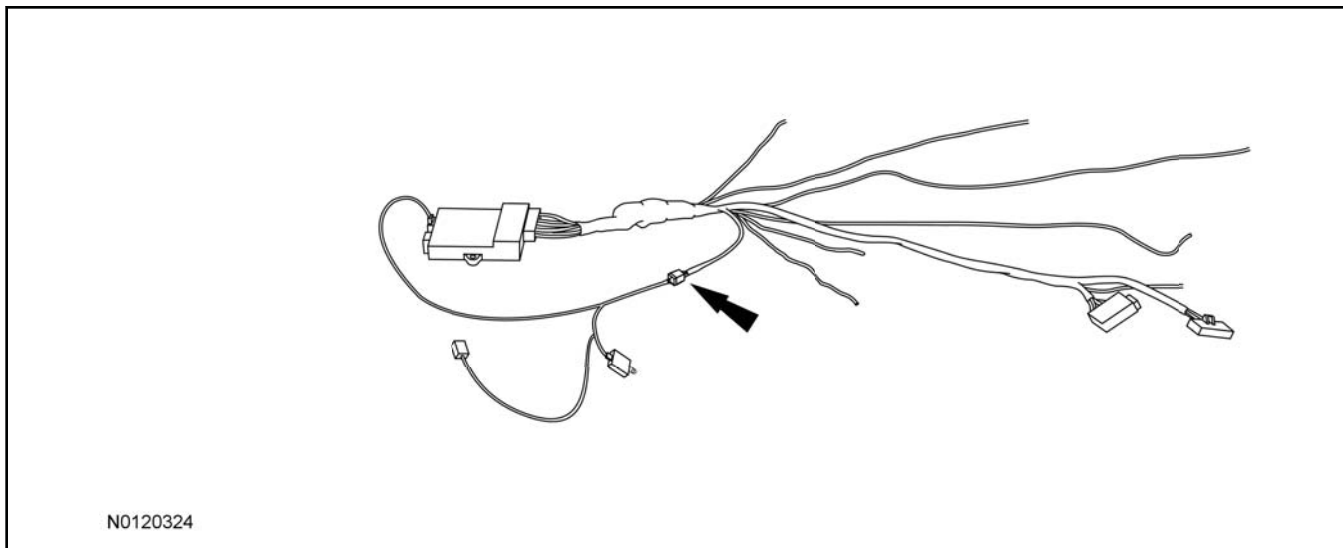
**INSTALLATION (Continued)****Identify Circuit Wires For Connections****NOTE:**

For vehicle specific wiring diagram(s) [click here](#).

**NOTE:**

For proper wire splicing techniques [click here](#).

24. Connect the Black ground wire from the remote start module harness to the chassis ground point on the passenger side.
- Chassis ground points are located near the passenger side sill plate.

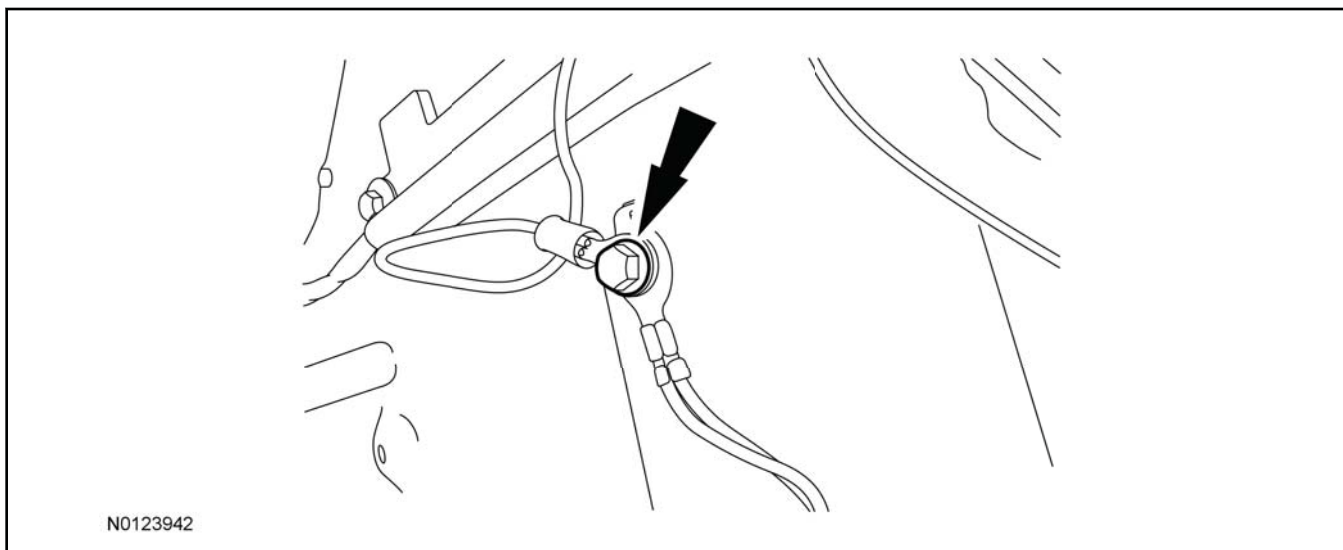
**25. NOTE:**

A DVOM connected to the correct wire will show 12V, then show 0V when the horn button is held. A logic probe will show power on the correct wire, then show ground when the horn button is held.

Identify the Brown horn circuit wire in the steering column harness.

**INSTALLATION (Continued)**

26. Connect the Brown/Black wire from the remote start module harness to the Brown horn circuit wire in the steering column harness.

27. **NOTE:**

This circuit should be tested with ignition OFF.

**NOTE:**

A DVOM connected to the correct wire will show open, then show 0V when the door lock switch is pressed.

A logic probe will show open on the correct wire, then show ground when the door lock switch is pressed.

Identify the Yellow/Gray power door lock circuit wire at the body control module (BCM) connector C2280G pin 6.

28. Connect the Blue wire from the remote start module harness to the Yellow/Gray power door lock circuit wire at the BCM connector C2280G pin 6.

29. **NOTE:**

A DVOM connected to the correct wire will show 0V, then show 12V while depressing the brake pedal.

A logic probe will show ground on the correct wire, then show power while depressing the brake pedal.

Identify the Blue/Gray brake switch circuit wire at the brake switch harness.

30. Connect the Brown wire from the remote start module harness to the Blue/Gray brake switch circuit wire at the brake switch harness.

31. **NOTE:**

A DVOM connected to the correct wire will show 0V with the vehicle door(s) open and the dome light ON, then show 12V with the vehicle door(s) closed and the dome light OFF.

**NOTE:**

A logic probe connected to the correct wire will show ground with the vehicle door(s) open and the dome light ON, then show power with the vehicle door(s) closed and the dome light OFF.

**NOTE:**

Be sure that the dome light has timed out and is OFF before performing the door closed test.

Be sure that the dome lamp is illuminated before performing the door open test.

Identify the Yellow/Gray dome light circuit wire at the BCM connector C2280C pin 5.

32. Connect the Green/Violet wire from the remote start module harness to the Yellow/Gray dome light circuit wire at the BCM connector C2280C pin 5.

33. **NOTE:**

A DVOM connected to the correct wire will show low power with the headlamp switch in the OFF position, then show 0V with the headlamp switch in the parking lights ON position.

**NOTE:**

A logic probe will show ground with the headlamp switch in the ON position and OPEN with the switch in the OFF position.

**INSTALLATION (Continued)**

Identify the Yellow/Blue parking lights circuit wire at the headlamp switch.

34. Connect the White wire from the remote start module harness to the Yellow/Blue parking lights circuit wire at the headlamp switch.

35. **NOTE:**

A DVOM connected to the correct wire will show 0V then show power with the brake pedal depressed.

**NOTE:**

A logic probe will show ground and then power with the brake pedal depressed.

Identify the Green/Blue brake pedal switch circuit wire at the brake pedal switch harness.

36. Connect the Dark Green wire from the remote start module harness to the Green/Blue brake pedal switch circuit wire at the brake pedal switch harness.

37. **NOTE:**

A DVOM connected to the correct wire will show near 0V then show 12V when the ignition switch is pressed.

**NOTE:**

A logic probe will show open/low power and then power when the ignition switch is pressed.

Identify the Gray/Brown ignition switch circuit wire at BCM connector C2280B Pin 12.

38. Connect the Pink wire from the remote start module harness to the Gray/Brown ignition switch circuit wire at BCM connector C2280B Pin 12.

39. **NOTE:**

A DVOM connected to the correct wire will show power then show 0V when the ignition switch is pressed.

**NOTE:**

A logic probe will show the wire rests at power and then ground when the ignition switch is pressed.

Identify the Yellow/Orange starter circuit wire at the passenger side kick panel connector C212 Pin 43.

40. Connect the Violet wire from the remote start module harness to the Yellow/Orange starter circuit wire at the passenger side kick panel connector C212 Pin 43.

41. **NOTE:**

A DVOM connected to the correct wire will show power, then show 0V when the door is unlocked. A logic probe will show power on the correct wire, then show ground when the door is unlocked.

Identify the Blue/Brown Unlock Sense circuit wire at BCM connector C2280G Pin 5.

42. Connect the Blue/Orange wire from the remote start module harness to the Blue/Brown Unlock Sense circuit wire at BCM connector C2280G Pin 5.

43. **NOTE:**

For vehicle specific wiring diagram(s) [click here](#).

**INSTALLATION (Continued)****NOTE:**

A DVOM connected to the correct wire will show 0V, then show power when the driver door is open.

A logic probe will show ground on the correct wire, then show power when the driver door is open.

Identify the Green/Violet door ajar circuit wire at BCM connector C2280G Pin 10.

44. Cut the Green/Violet door ajar circuit wire at BCM connector C2280G Pin 10.
45. Splice one of the following wires to each side of the previously cut Green/Violet door ajar circuit wire at BCM connector C2280G Pin 10.
  - Orange/Black wire from the Remote start module harness.
  - Orange wire from the Remote start module harness.

**Power Connection**46. **NOTE:**

A DVOM connected to the correct wire will show 12V with the ignition in the OFF position.

**NOTE:**

A logic probe will show power with the ignition in the OFF position.

Identify the red battery circuit wire at the BCM connector C2280A Pin 1.

47. Connect the Red wire from the remote start module harness to the Red battery circuit wire at the BCM connector C2280A Pin 1.

**Install the Hood Safety Switch**48. **NOTE:**

Route the hood safety switch wire carefully avoiding any moving parts or components that can produce excessive heat.

**NOTE:**

Using a piece of convolute adds in the appearance of the installation.

**NOTE:**

The switch should be positioned about 30 degrees below parallel to the ground to accommodate for parking on inclines.

Failure to position the switch properly could result in one of the following:

- False alarm trips
- Non-remote start events
- Inadvertent shutdown during remote start

Locate an easy to access area to the left of the driver side hood hinge and install the hood safety switch using the supplied metal screws.

49. Apply rustproofing compound (PM-13-A) to the drilled hole and torque the screw to 1.00 Nm (10 lb-in).



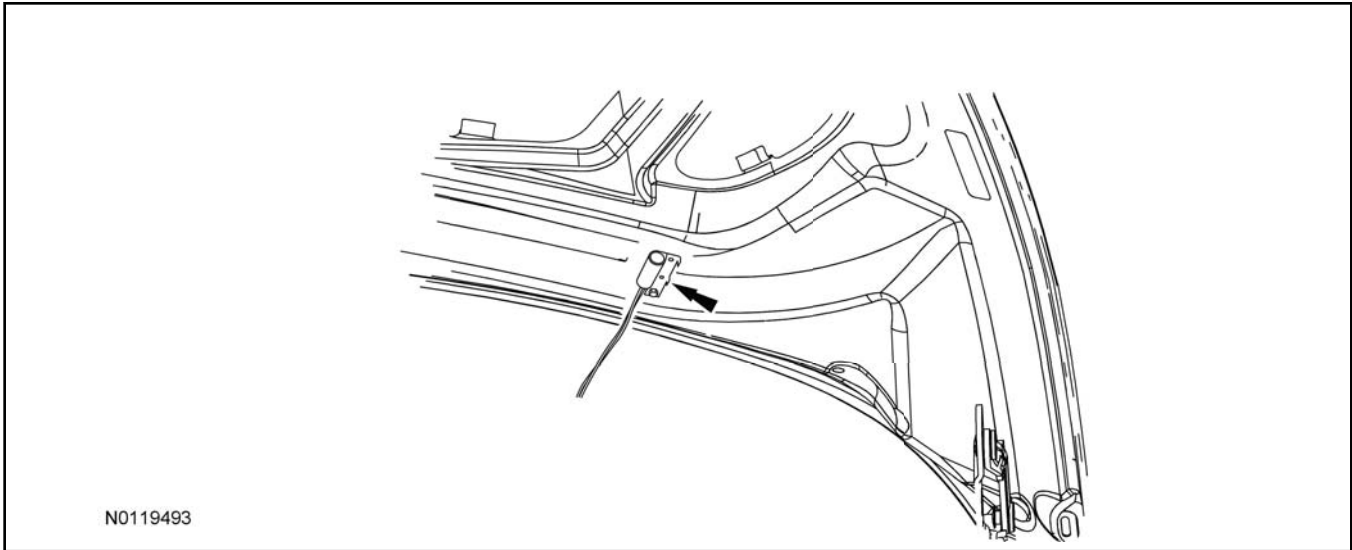

50. Connect the hood switch ground wire to a suitable location on the bulkhead.

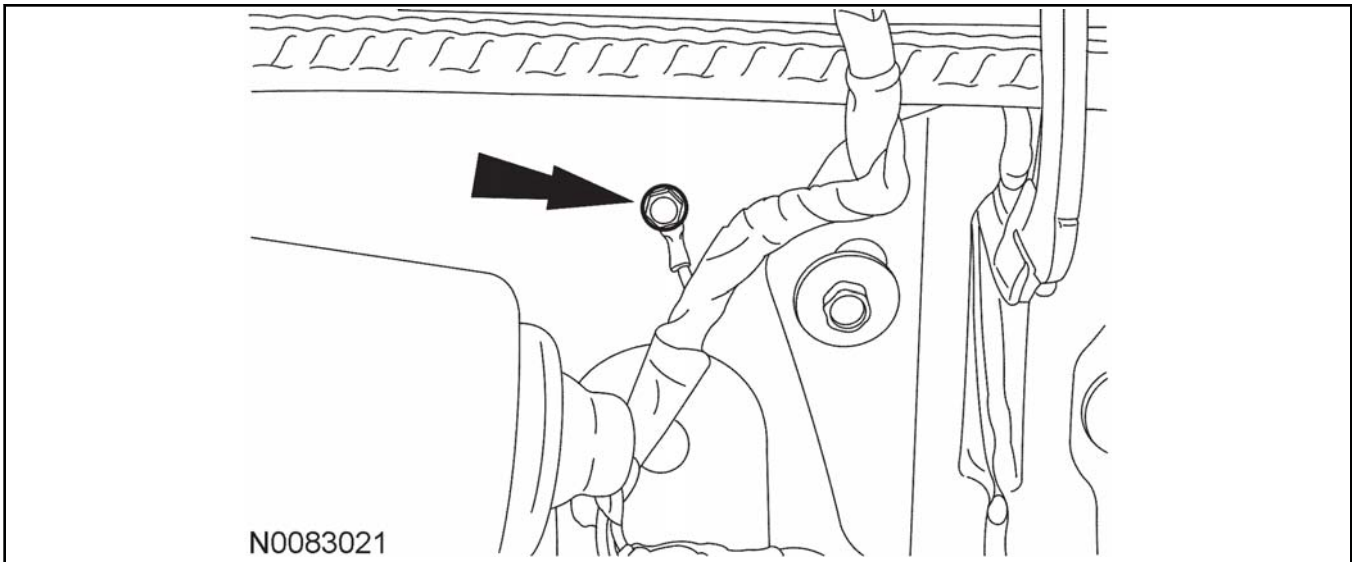

51. **NOTE:**  
Place the label on the radiator fan shroud or similar area.  
Install the underhood warning label.

**INSTALLATION (Continued)**

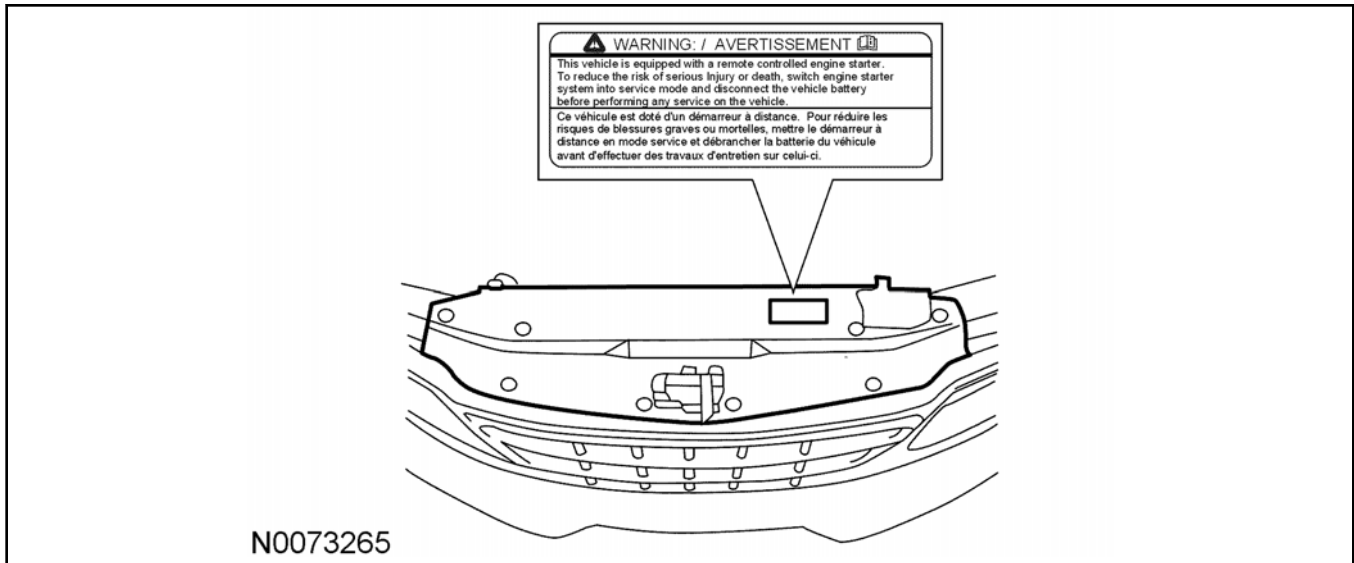

52. Route the Gray hood safety switch wire through the bulkhead into the engine compartment and attach to the hood safety switch.

53. Connect the antenna to the RMST control module.

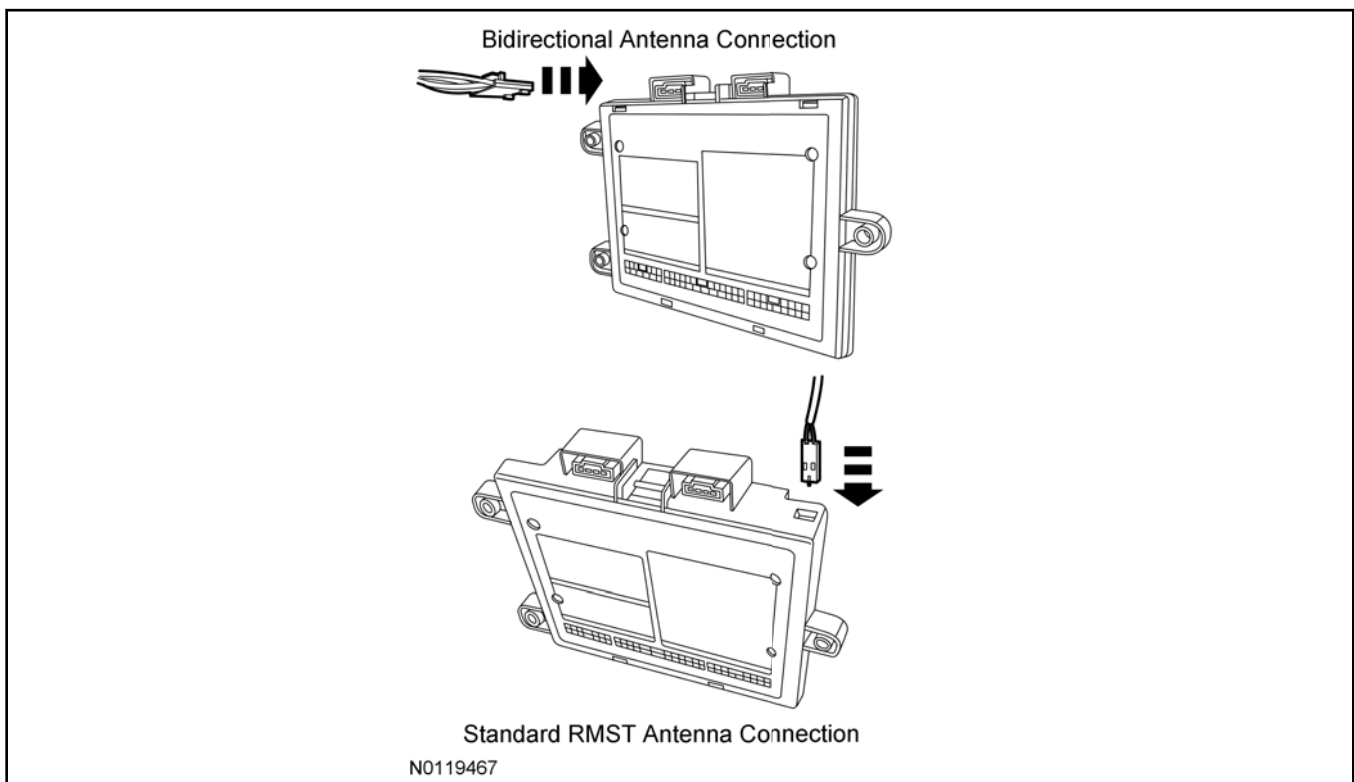

**Program the RMST System**

54. [For the RMST programming section for this vehicle click here.](#)

**Secure RMST Harness and Control Module**

55. Use the supplied tie-straps to secure the RMST harness wires.

**INSTALLATION (Continued)**

---

**56. NOTE:**

Do not mount the control module in the knee bolster area.  
Secure the control module at three points to the vehicle.

Use the supplied long tie-straps to mount the RMST control module to the underdash wiring harness, to the right of the steering column.

**All Vehicles**

- 57. Install the upper and lower steering column shrouds.  
Install the retainers.
- 58. Install the glove compartment.
- 59. Install the RH lower instrument panel insulator.

**NOTE:**

The following step is for bi-directional RMST kits only.

- 60. Hang the customer's rear view mirror information card on the rear view mirror.

; YbYfU`DfcWXi fYg

**Programming**

**Special Tool(s)**

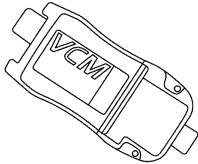
 <p>ST2834-A</p>	<p><i>Vehicle Communication Module (VCM) and Integrated Diagnostic System (IDS) software with appropriate hardware, or equivalent scan tool</i></p>
---	---

**Programming - Standard Remote Start**

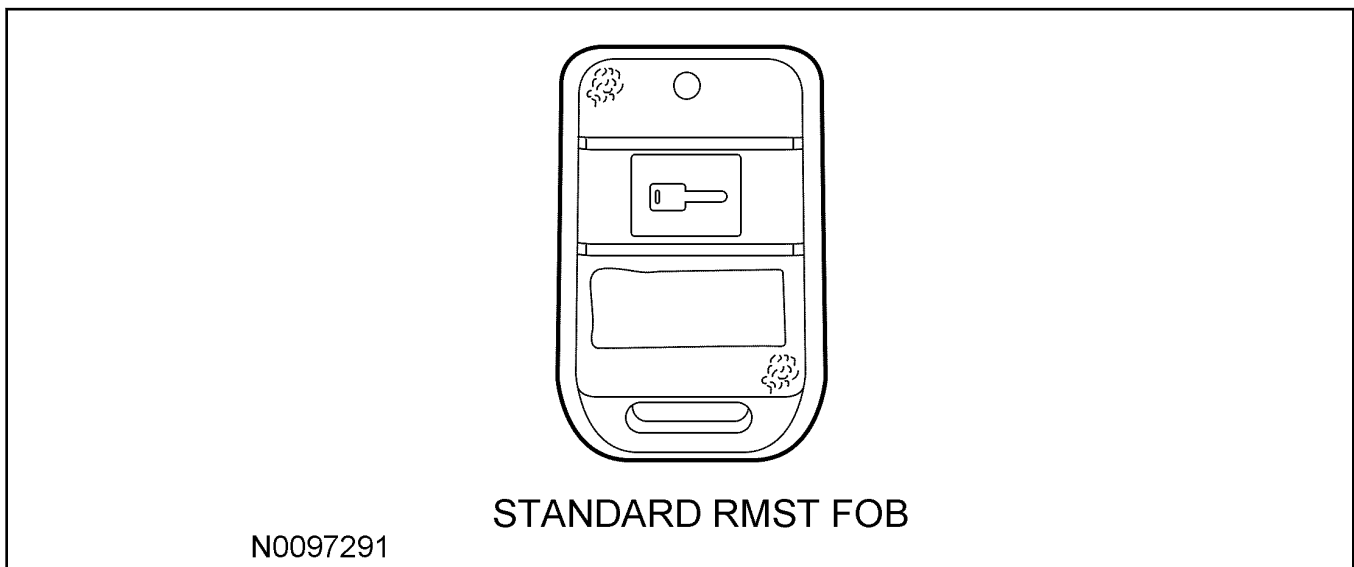

1. **NOTE:**  
If the remote start options (Key-in sense polarity, door ajar polarity, or tach mode) are not programmed correctly, vehicle will not remote start or operate properly.

**NOTE:**  
Make sure that the hood and doors are closed before proceeding.

**NOTE:**  
The LED on the remote start harness must be visible to complete module programming.

**NOTE:**  
The remote start override button must be accessible.

**Programming Options: Entering Programming Mode**

2. See chart below for programming information.

## ; YbYfU`DfcWXi fYg (Continued)

## Program Bank 2 Chart (5 Honks)

BANK	OPTIONS	DESCRIPTION	LED
2	1	TACHLESS MODE	ON

3. Press and hold the brake pedal.
4. Turn the ignition key to the RUN position.
  - The dome light will turn off.
5. Press and hold the remote start system override button for at least 10 seconds. After 10 seconds the horn will honk 3 times, indicating the system is now in the learn mode. Release the brake pedal and the RMST override button.
6. Press and release the override button. The horn will honk 4 times indicating the system has entered the first program bank. If not, please check the following:
  - Brake pedal switch wire solder connection.
  - Hood closed and Grey hood safety switch wire solder connection.
  - All doors closed and dome light circuit wire solder connections.
  - The key is in the RUN position.
  - The software cartridge is firmly seated in the RMST module.
  - The RMST harness connections are firmly seated in the RMST module.

**NOTE:**

If you require additional assistance: CALL 1-800-FORD KEY.

7. Press and release the override button again. The horn will honk 5 times indicating the system has entered the second program bank.
8. Press and release the brake pedal.
  - The horn will honk 1 time indicating the system has entered the option 1 of the second program bank.

**NOTICE:**

**When turning LED on or off using remote start fob button quickly press and immediately release the remote start button. Failure to quickly release the remote start fob button will result in system defaulting to the factory options.**

9. The LED must be on for option 1. If the LED is illuminated no action is required. If the LED is not illuminated press the remote start fob button and verify the LED illuminates.

**NOTE:**

If the remote start fob button is held for more than 3 seconds the system will chirp the horn 4 times, indicating the system has returned to factory default settings. If this occurs return to step 1 of the programming section and reprogram the remote start module.

**NOTE:**

The remote start module is now programmed.

; YbYfU`DfcWXi fYg'(Continued)

10. Remove the ignition key.

### Programming the DNA-9 Using Diagnostic Equipment

#### NOTE:

This procedure only programs the Passive Anti-Theft System (PATS) portion of the key into the Instrument Panel Cluster (IPC).

11. With an Intelligent Access key in the vehicle, turn the ignition on by pushing the Start button without depressing the brake.
12. From the scan tool, enter TOOLBOX. Select Body>Security>PATS Functions and follow the Integrated Diagnostic System (IDS) on-screen instructions to enter PATS security access.
13. Once security access is granted, prepare the remote start module for PATS programming. Press and hold the brake pedal.
14. Remove the Intelligent Access key from the vehicle and place on workbench 10 feet from the vehicle.
15. Press and hold the remote start system override button on the remote start harness for at least 10 seconds.
  - After 10 seconds the horn will honk 3 times, indicating the system is now in the learn mode.
  - Release the brake pedal and the remote start override button.
16. Press and release the override button 1 time. The horn should honk 4 times.
17. Quickly press and release the Remote Start button on the remote start key fob 1 time. Verify that the LED has turned on. This indicates that the remote start module is ready for programming to the vehicle PATS system.

#### NOTE:

You may need to perform the following step **TWICE** in order to successfully program the Remote Start system.

18. From the scan tool menu, select "Program additional transponder key". Follow the on screen prompts to program additional keys and to program the remote start system to the vehicle.
19. Disconnect the scan tool, and turn off the ignition when complete.

### Functional Test - Standard Remote Start

#### NOTE:

If during any of the steps of the functional test, the remote start system or vehicle doesn't react or perform accordingly, please refer to the remote start troubleshooting guide.

#### NOTE:

For remote start troubleshooting guide click [here](#).

20. Make sure all doors are closed but hood is open and windows are down (doors will be locking).
21. Press and hold the Start button on the remote control key fob for 2-3 seconds, the Horn should honk once indicating receipt of the start request.

## ; YbYfU`DfcWwXi fYg (Continued)

22. The remote start systems should turn on the ignition, but then honk the horn twice and shut down indicating the hood is open.
23. Attempt to re-start the vehicle again using the key fob.
24. Remove the key and open a door.
25. Attempt to re-start the vehicle again using the key fob.
26. The remote start systems should turn on the ignition, but then honk the horn three times and shutdown indicating a door is open.
27. Close the door.
28. Attempt to re-start the vehicle again using the key fob.
29. Once the vehicle starts, verify that all heat and A/C functions operate normally and that the doors have locked.
30. On vehicles equipped with power window interrupt, Attempt to close windows to check power window interrupt function.
31. Once all systems have been checked, open the door, or press the brake pedal. The remote start systems should shut down.
32. Restart the vehicle then unlock and open the door. The remote start systems should shut down.
33. Verify that the vehicle can be restarted with the Intelligent Access key, 3-5 seconds after engine shutdown.

**Troubleshooting**

34. **NOTE:**When attempting to remote start your vehicle, the system has several safety checks that it performs. If any of these inputs are present that should not be, the system will respond back to you with several horn "chirps" to help you identify which input is present. These "chirps" will occur after initiating a start sequence with the transmitter, the system will turn on the ignition, but then respond back with several horn "chirps" and abort the starting process.

**Example:** Depress the remote start fob button for 3 seconds and then release. The vehicle horn will "chirp" one time to indicate that RMST signal was received. If the vehicle doesn't start and the horn "chirps" 3 times, there is a fault - "Vehicle Door is Open"

CHIRPS	PROBLEM
1 Chirp	DNA-9 not programmed correctly, or the DNA-9 antenna ring is damaged.
2 Chirps	BRAKE is being pressed, or the HOOD is open.
3 Chirps	One of the vehicles DOORS are open.
4 Chirps	TACH not programmed.
5 Chirps	The KEY is in the ignition.
6 Chirps	The remote start system is in SERVICE/VALET mode.

; YbYfU`DfcWXi fYg (Continued)

**Programming Bi-directional Remote Start**

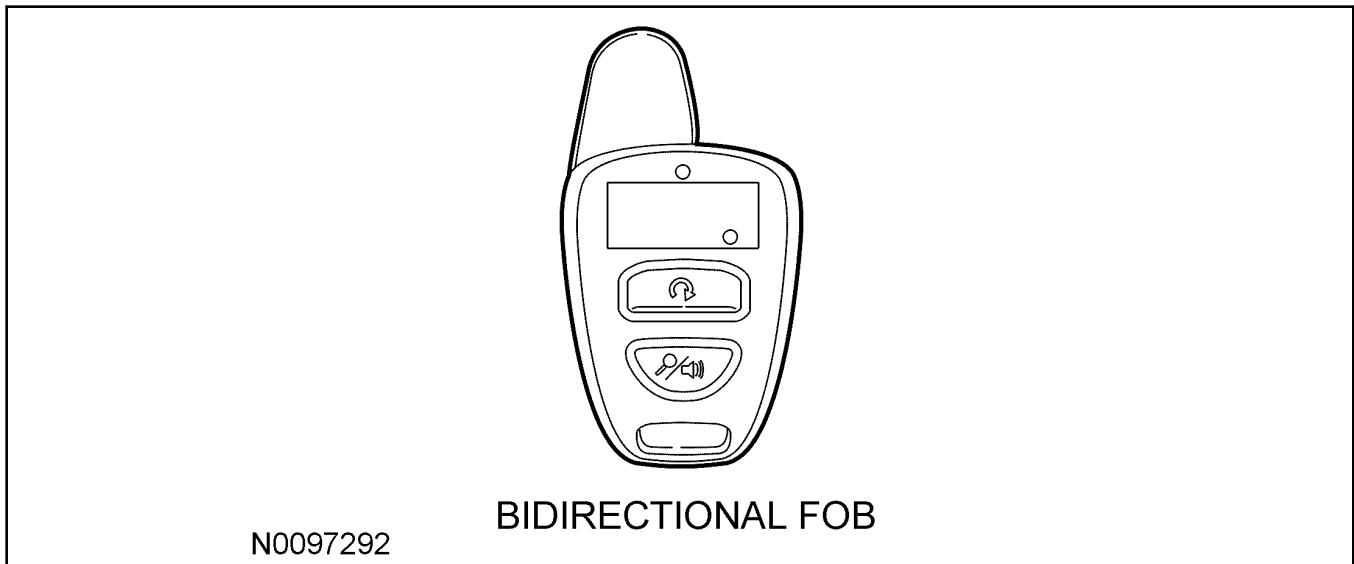

35. **NOTE:**  
If the remote start options (Key-in sense polarity, door ajar polarity, or tach mode) are not programmed correctly, vehicle will not remote start or operate properly.

**NOTE:**  
Make sure that the hood and doors are closed before proceeding.

**NOTE:**  
The LED on the remote start harness must be visible to complete module programming.

**NOTE:**  
The remote start override button must be accessible.

**Programming Options: Entering Programming Mode**

36. See chart below for programming information.

**Program Bank 2 Chart (5 Honks)**

BANK	OPTIONS	DESCRIPTION	LED
2	1	TACHLESS MODE	ON

- 37. Press and hold the brake pedal.
- 38. Turn the ignition key to the RUN position.
  - The dome light will turn off.
- 39. Press and hold the remote start system override button for at least 10 seconds. After 10 seconds the horn will honk 3 times, indicating the system is now in the learn mode. Release the brake pedal and the RMST override button.
- 40. Press and release the override button. The horn will honk 4 times indicating the system has entered the first program bank. If not, please check the following:
  - Brake pedal switch wire solder connection.



---

**; YbYfU`DfcWXi fYg (Continued)**

- Hood closed and Grey hood safety switch wire solder connection.
- All doors closed and dome light circuit wire solder connections.
- The key is in the RUN position.
- The software cartridge is firmly seated in the RMST module.
- The RMST harness connections are firmly seated in the RMST module.

**NOTE:**

If you require additional assistance: CALL 1-800-FORD KEY.

41. Press and release the override button again. The horn will honk 5 times indicating the system has entered the second program bank.
42. Press and release the brake pedal.
  - The horn will honk 1 time indicating the system has entered the option 1 of the second program bank.

**NOTICE:**

**When turning LED on or off using remote start fob button quickly press and immediately release the remote start button. Failure to quickly release the remote start fob button will result in system defaulting to the factory options.**

43. The LED must be on for option 1. If the LED is illuminated no action is required. If the LED is not illuminated press the remote start fob button and verify the LED illuminates.

**NOTE:**

If the remote start fob button is held for more than 3 seconds the system will chirp the horn 4 times, indicating the system has returned to factory default settings. If this occurs return to step 1 of the programming section and reprogram the remote start module.

**NOTE:**

The remote start module is now programmed.

44. Remove the ignition key.

**Programming the DNA-9 Using Diagnostic Equipment****NOTE:**

This procedure only programs the Passive Anti-Theft System (PATS) portion of the key into the Instrument Panel Cluster (IPC).

45. With an Intelligent Access key in the vehicle, turn the ignition on by pushing the Start button without depressing the brake.
46. From the scan tool, enter TOOLBOX. Select Body>Security>PATS Functions and follow the Integrated Diagnostic System (IDS) on-screen instructions to enter PATS security access.
47. Once security access is granted, prepare the remote start module for PATS programming. Press and hold the brake pedal.
48. Remove the Intelligent Access key from the vehicle and place on workbench 10 feet from the vehicle.

---

**; YbYfU`DfcWwXi fYg (Continued)**

49. Press and hold the remote start system override button on the remote start harness for at least 10 seconds.
  - After 10 seconds the horn will honk 3 times, indicating the system is now in the learn mode.
  - Release the brake pedal and the remote start override button.
50. Press and release the override button 1 time. The horn should honk 4 times.
51. Quickly press and release the Remote Start button on the remote start key fob 1 time. Verify that the LED has turned on. This indicates that the remote start module is ready for programming to the vehicle PATS system.

**NOTE:**

You may need to perform the following step **TWICE** in order to successfully program the Remote Start system.

52. From the scan tool menu, select "Program additional transponder key". Follow the on screen prompts to program additional keys and to program the remote start system to the vehicle.
53. Disconnect the scan tool, and turn off the ignition when complete.

**Functional Test - Bi-directional Remote Start****NOTE:**

If during any of the steps of the functional test, the remote start system or vehicle doesn't react or perform accordingly, please refer to the remote start troubleshooting guide.

**NOTE:**

For remote start troubleshooting guide [click here](#).

54. Make sure all doors are closed but hood is open and windows are down (doors will be locking).
55. Press and hold the Start button on the remote control key fob for 2-3 seconds, the Horn should honk once indicating receipt of the start request.
56. The remote start systems should turn on the ignition, but then honk the horn twice and shut down indicating the hood is open.
57. Attempt to re-start the vehicle again using the key fob.
58. Remove the key and open a door.
59. Attempt to re-start the vehicle again using the key fob.
60. The remote start systems should turn on the ignition, but then honk the horn three times and shutdown indicating a door is open.
61. Close the door.
62. Attempt to re-start the vehicle again using the key fob.
63. Once the vehicle starts, verify that all heat and A/C functions operate normally and that the doors have locked.
64. On vehicles equipped with power window interrupt, Attempt to close windows to check power window interrupt function.

## ; YbYfU`DfcWXi fYg (Continued)

65. Once all systems have been checked, open the door, or press the brake pedal. The remote start systems should shut down.
66. Restart the vehicle then unlock and open the door. The remote start systems should shut down.
67. Verify that the vehicle can be restarted with the Intelligent Access key, 3-5 seconds after engine shutdown.

**Troubleshooting**

68. **NOTE:** When attempting to remote start your vehicle, the system has several safety checks that it performs. If any of these inputs are present that should not be, the system will respond back to you with several horn "chirps" to help you identify which input is present. These "chirps" will occur after initiating a start sequence with the transmitter, the system will turn on the ignition, but then respond back with several horn "chirps" and abort the starting process.

**Example:** Depress the remote start fob button for 3 seconds and then release. The vehicle horn will "chirp" one time to indicate that RMST signal was received. If the vehicle doesn't start and the horn "chirps" 3 times, there is a fault - "Vehicle Door is Open".

CHIRPS	PROBLEM
1 Chirp	DNA-9 not programmed correctly, or the DNA-9 antenna ring is damaged.
2 Chirps	BRAKE is being pressed, or the HOOD is open.
3 Chirps	One of the vehicles DOORS are open.
4 Chirps	TACH not programmed.

# '11 Fiesta Push Button Start

## TYPE "A" CUSTOM WIRE HARNESS

### RMST MODULE WIRE HARNESS

	Color	Function
A-7	PINK	Ignition Input/Output
A-24	VIOLET	Starter Output
A-4	RED	Battery
A-13	ORANGE	Door Ajar Switch 1
C-9	ORANGE/BLACK	Door Ajar Switch 2
B-9	BLUE/ORANGE	Unlock Sense
A-20	GREEN/VIOLET	Door Ajar Switch Input

	Color	Function
A-21	BROWN/BLACK	Horn Relay Output
A-1	WHITE	Parking Light Output

### DRIVER'S KICK PANEL HARNESS

	Color	Function
A-5	BLACK	Ground
A-24	BLUE	Door Lock Output
B-7	BROWN	Brake Input
A-14	DARK GREEN	Cruise Control Deactivation Switch

### UNDER HOOD HARNESS

	Color	Function
A-19	GRAY	Hood Open Switch Input

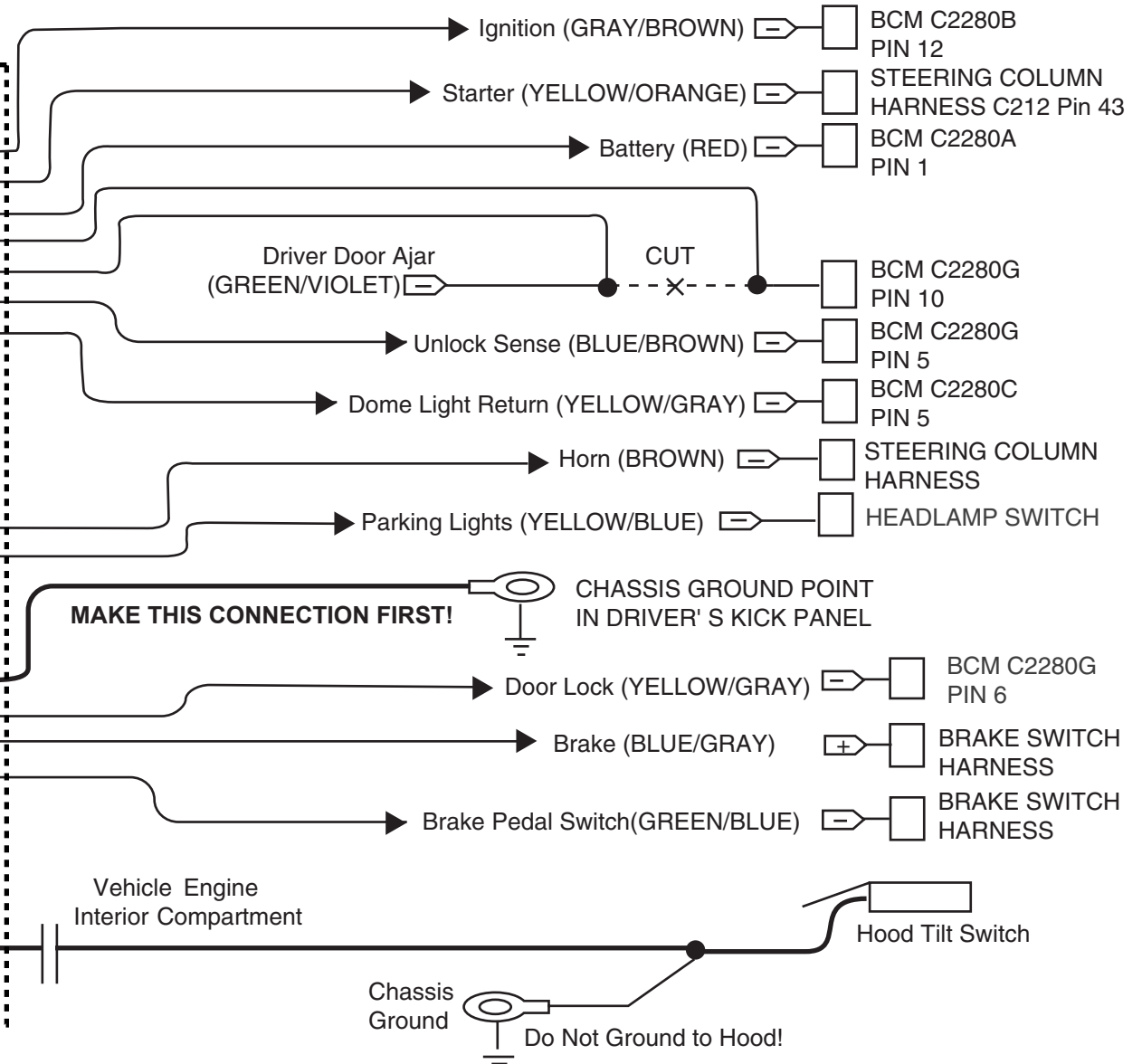

### Body Control Module (BCM)

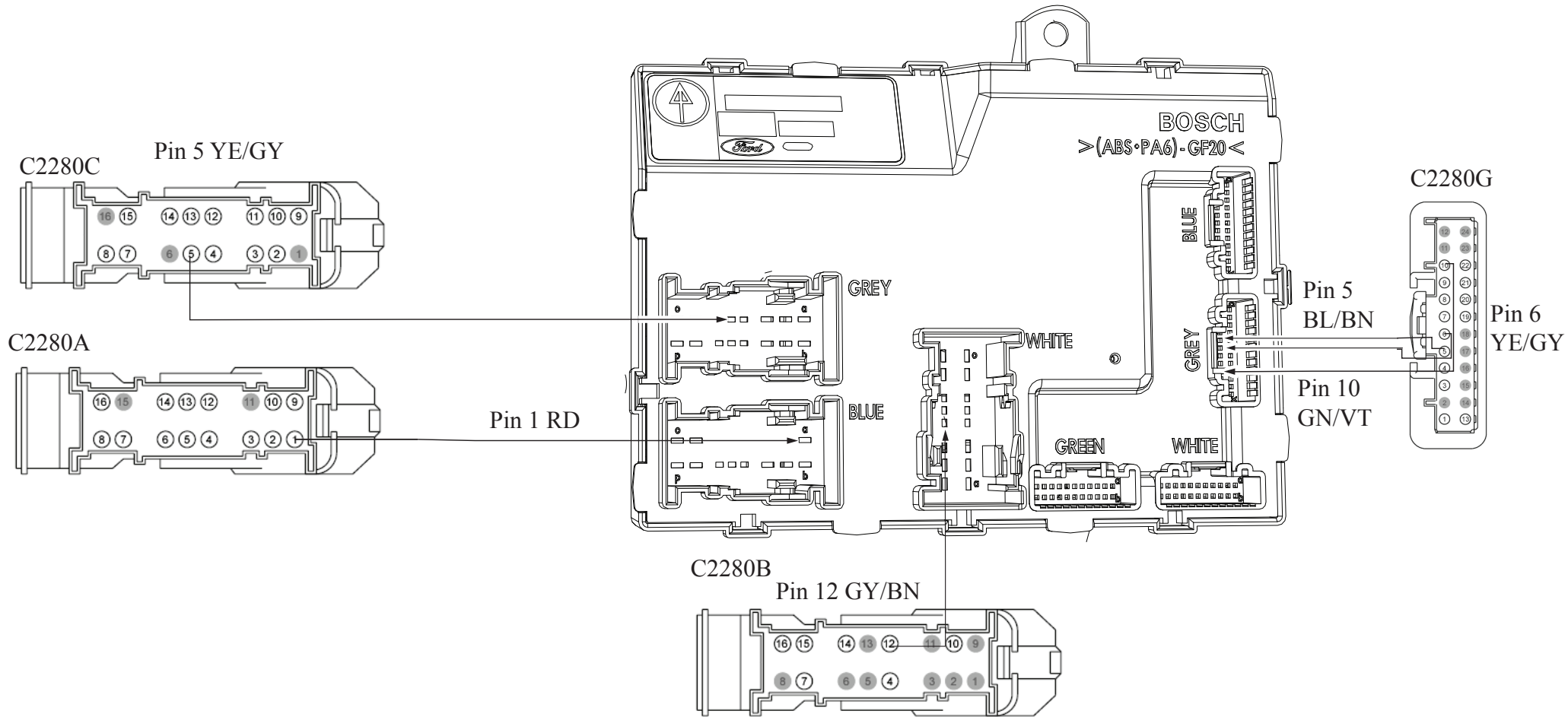

# REMOTE START SYSTEM INSTALLATION

## CONTENTS

### INSTALLATION

[Remote Start](#)

### GENERAL PROCEDURES

[Proper Splicing Techniques](#)

[Programming - Standard Remote Start](#)

[Functional Test - Standard Remote Start](#)

[Programming - Bidirectional Remote Start](#)

[Functional Test - Bidirectional Remote Start](#)

[Troubleshooting](#)

### WIRING DIAGRAMS

[Vehicle Specific Wiring Diagrams](#)

# INSTALLATION

## Remote Start

### Remote Start System RMST Components

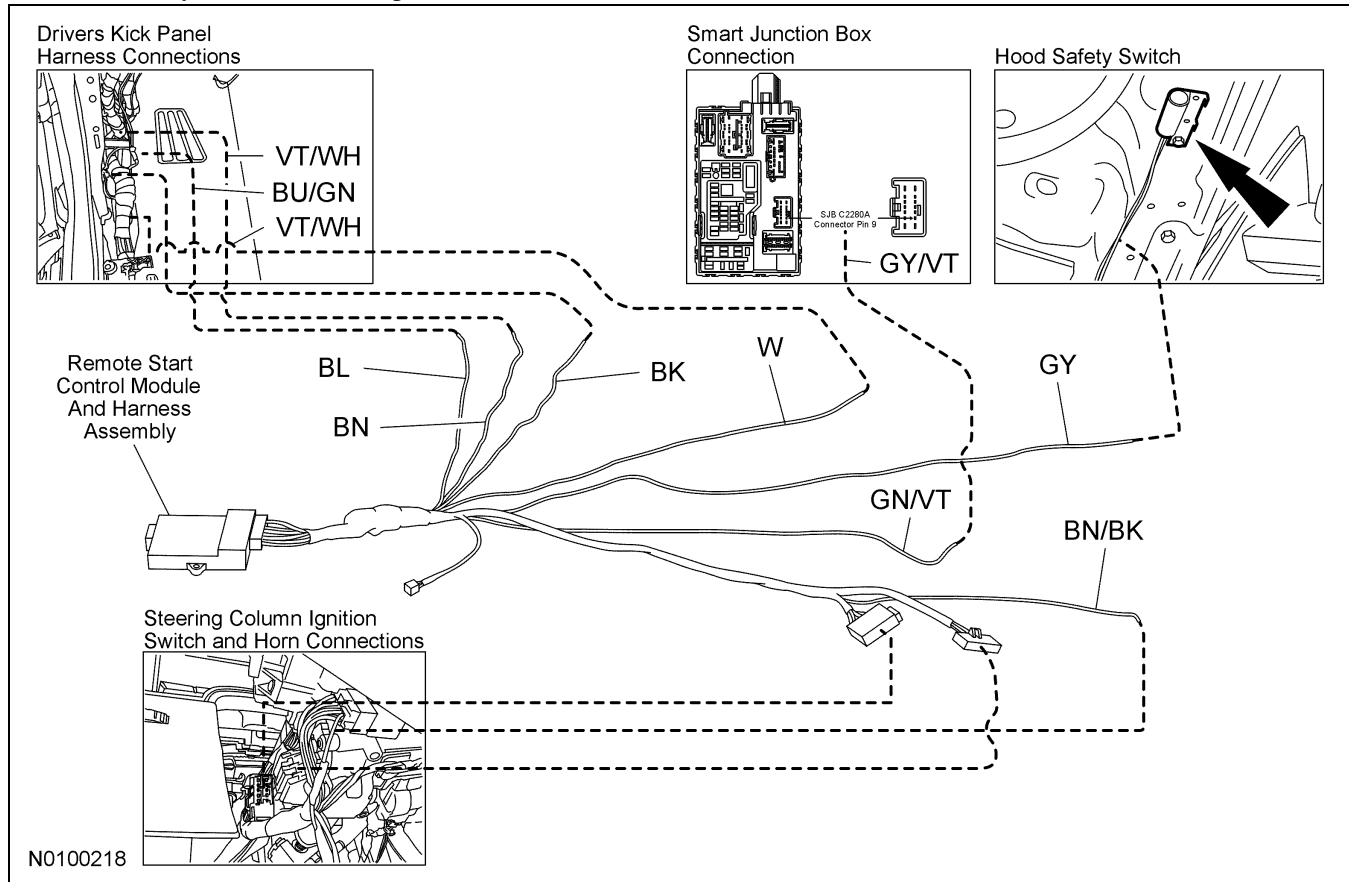

### Fusion/Milan/MKZ

**NOTICE:** Remote start systems are only applicable to vehicles with automatic transmissions.

**NOTE:** Both original keys are required for all remote start systems on vehicles equipped with SECURILOCK.

1. Verify correct kit number.

**INSTALLATION (Continued)**

**Review Remote Start Installation Kit Contents**

**NOTE:** Use kit number AL2Z-19G364-A (GFA) REMOTE START SYSTEM

AG1Z-19G364-A (GFA) BIDIRECTIONAL REMOTE START SYSTEM.

**NOTE:** Kits are vehicle specific and are not interchangeable.

2. Review the RMST kit contents.

**Remote Start System Standard Kit (RMST) Type - "A"**

QUANTITY	DESCRIPTION
1	TYPE - "A" MODULE ASSEMBLY
1	RMST SOFTWARE CARTRIDGE ASSEMBLY
2	1 BUTTON POWERCODE TRANSMITTER
1	TYPE - "A" CUSTOM WIRING HARNESS
1	ANTENNA
1	HOOD SAFETY SWITCH ASSEMBLY
1	INSTALLATION PARTS BAG
1	FUSE PARTS BAG
1	OPERATORS INSTRUCTIONS
1	UNDERHOOD WARNING LABEL
1	SECURILOCK INTERFACE KIT

3. Review the RMST bidirectional kit contents.

**Remote Start System Bidirectional Kit (RMST) Type - "A"**

QUANTITY	DESCRIPTION
1	TYPE - "A" MODULE ASSEMBLY
1	RMST SOFTWARE CARTRIDGE ASSEMBLY
1	2 BUTTON POWERCODE TRANSMITTER
1	TYPE - "A" CUSTOM WIRING HARNESS
1	ANTENNA
1	ANTENNA HARNESS
1	HOOD SAFETY SWITCH ASSEMBLY
1	INSTALLATION PARTS BAG
1	FUSE PARTS BAG
1	OPERATORS INSTRUCTIONS
1	UNDERHOOD WARNING LABEL
1	SECURILOCK INTERFACE KIT

**Module Preparation**

- Place the supplied fuses into the power distribution block on the remote start control module.
  - Move the polarity jumpers to their proper locations on the control module, see illustration.



INSTALLATION (Continued)

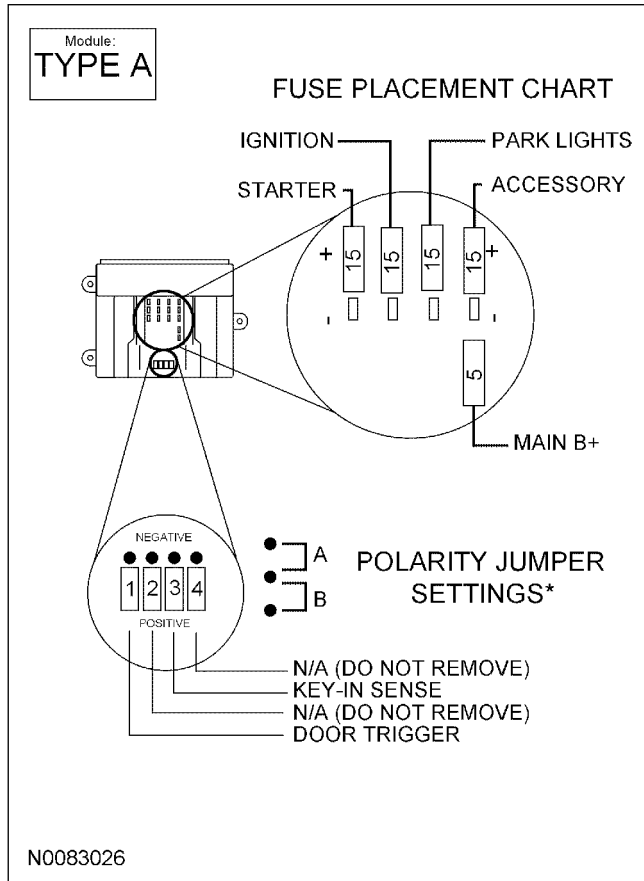

- Place the software cartridge onto the RMST control module.

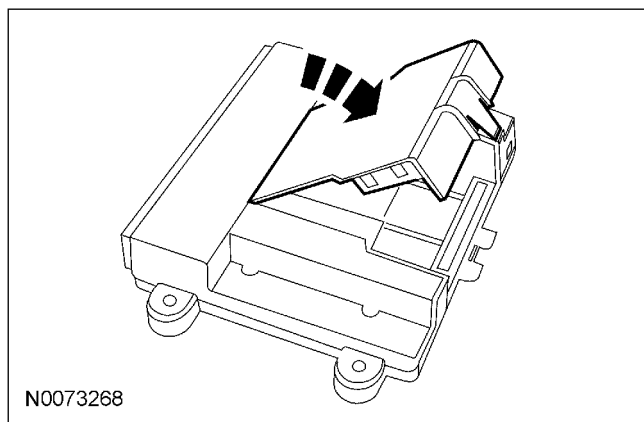

- Plug the wiring harness(es) into the module.
  - A - Harness: 24-way, used on all systems.
  - B - Harness: 10-way, used on all systems with RMST.

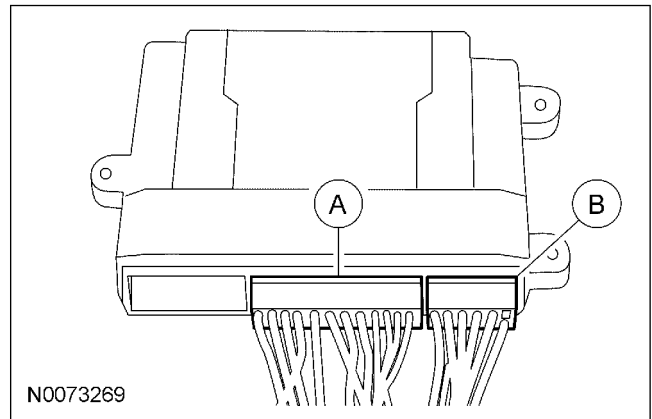

- NOTE:** Do not cut the override programming button off of the harness, it is used for all installations.

**NOTE:** For vehicle specific wiring diagram(s) [click here](#).

Referring to the vehicle specific wiring section for the system being installed, gather all individual wires that will be routed to the same areas of the vehicle into groups. Cover each wire group with electrical tape for approximately 18". Depending on the vehicle, there will be 2 to 5 different wire groups. Trim the unused wires approximately 6 - 8" from the module.

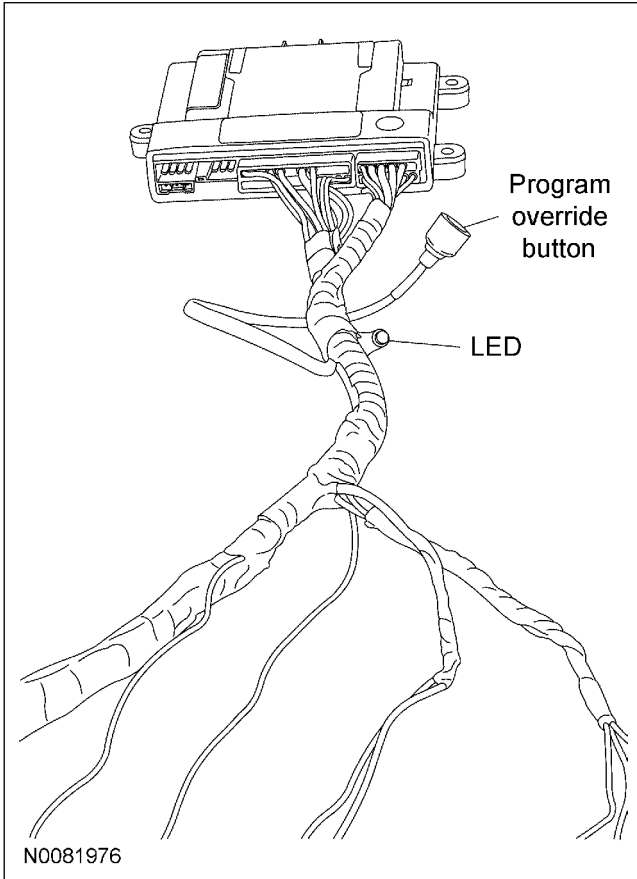
**INSTALLATION (Continued)**

8. Tape the harness sections together, making sure to cover all of the unused wires.

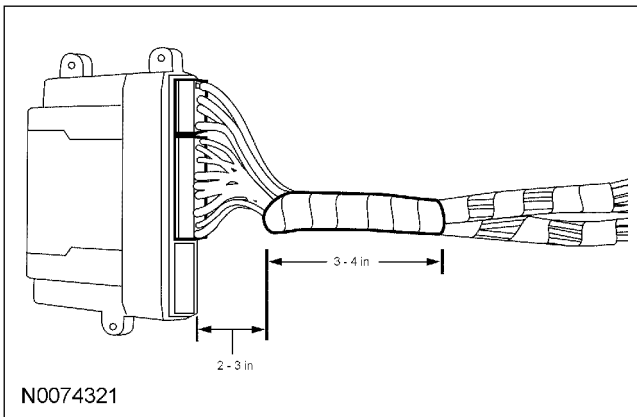
**Vehicle Preparation**

**NOTE:** The instrument panel steering column cover is held in place by tabs that clip to the instrument panel.

9. Remove the instrument panel steering column cover by pulling straight outward.

**NOTE:** Release the upper steering column shroud, by pressing inward on the sides of the shroud and lifting upwards.

10. Remove the upper steering column shroud.
11. Release the tilt lever, remove the 3 screws and then remove the lower steering column shroud.
12. Remove the left hand scuff plate and cowl trim panel.

**Antenna Mounting**

**NOTE:** For good range of operation, the antenna must be installed correctly.

**NOTE:** Keep these points in mind when selecting a location and mounting the antenna.

- Do not mount the antenna behind or on any metal film or window tinting on the windshield.
  - Do not mount the antenna so that one of the antenna elements touches or crosses any vehicle wiring and/or metal.
  - On vehicles without metal film in the windshield around the rear view mirror, mount the antenna between the headliner and the rear view mirror.
  - On vehicles equipped with an electronic mirror, or on vehicles with metal film around the rearview mirror, mount the antenna approximately 3 inches below the mirror attachment point to the windshield and/or mirror electronics.
13. Choose a suitable mounting location following the guidelines above.

**Install The Antenna**

14. Clean the mounting surface using an alcohol base solution and a clean cloth.

**INSTALLATION (Continued)**

15. **NOTE:** Do not touch the adhesive, reduced adhesion may result.

**NOTE:** Make sure that the long wire on the antenna is pointing towards the top of the windshield since this wire will be routed along the headliner.

**NOTE:** The wire will be attached to the control module later in this procedure.

Remove the protective backing from the adhesive on the antenna and firmly press the body of the antenna to the windshield.

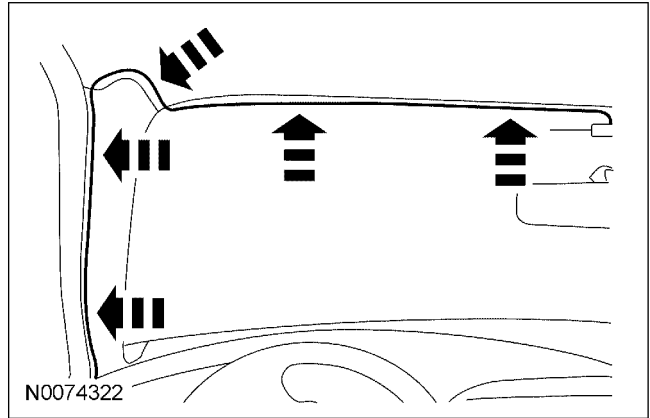

18. Reposition the A pillar trim panel.

**Install The Securilock Interface Kit**

19. Route the ring of the SECURILOCK interface antenna lead up along the steering column to the PATS transceiver location.

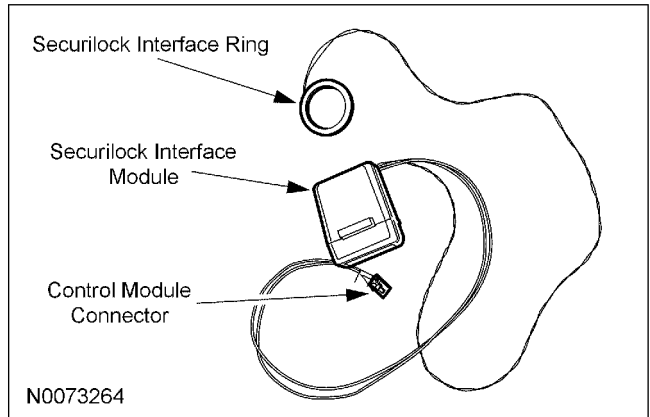
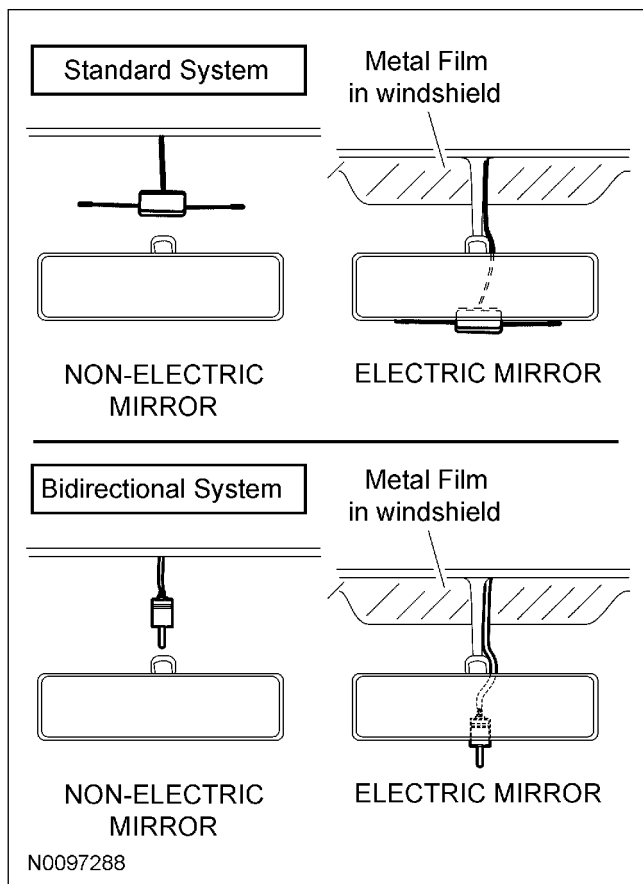

20. Following the directions on the supplied tube of adhesive primer, apply a thin coating around the transceiver antenna coil and allow to dry for approximately 5 minutes.

16. If necessary, position the A pillar trim slightly outward to provide access to route the antenna wire.

**NOTE:** Do not route the antenna wire over the top of the air bag.

17. Route the antenna cable along the headliner and down the A pillar towards the floor.

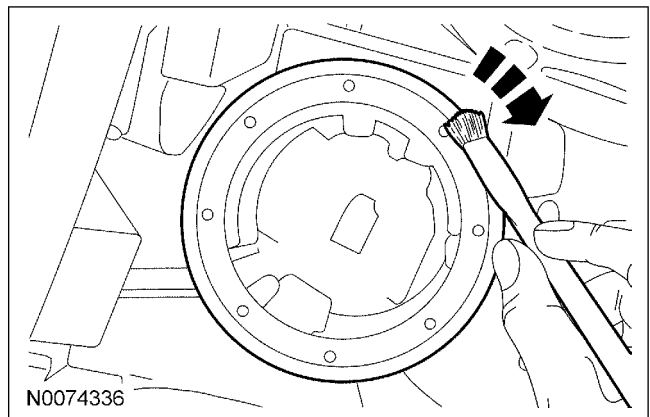

**INSTALLATION (Continued)**

21. **NOTICE:** Do not damage the transceiver ring during installation or while installing the steering column shroud.

A damaged transceiver ring will result in an inoperable remote start system.

Remove the protective backing from the SECURILOCK antenna ring. Place the SECURILOCK ring over the PATS transceiver and press firmly in place.

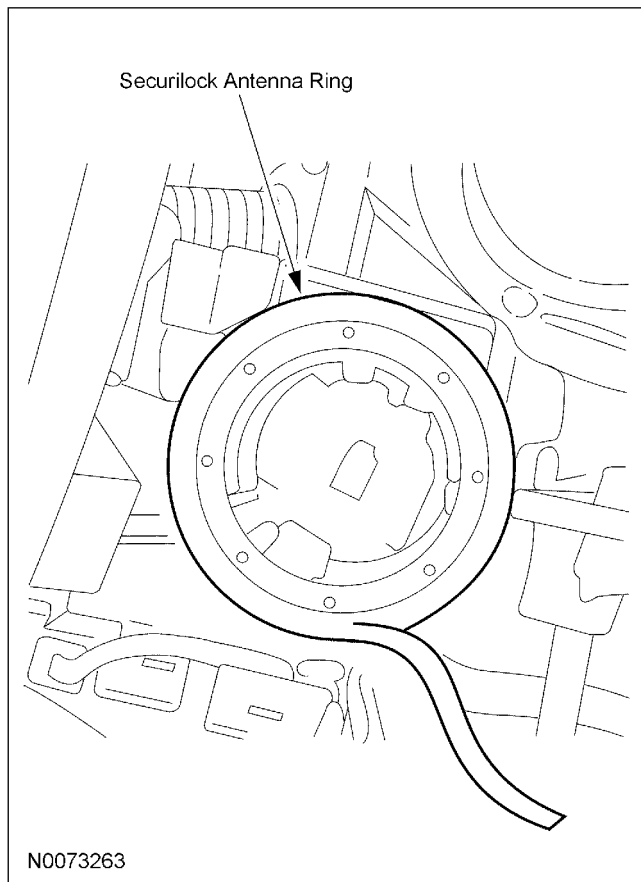
**Install The Securilock Interface Module**

22. **NOTE:** Do Not mount the SECURILOCK Interface Module to or within 3'' of a metal surface, including any underdash brackets, or in the knee bolster area.

Mount the SECURILOCK Interface Module to an underdash wiring harness using one of the supplied long tie wraps.

23. **NOTICE:** Do not attach the harness to the steering column.

Route the harness and connector to the module mounting location.

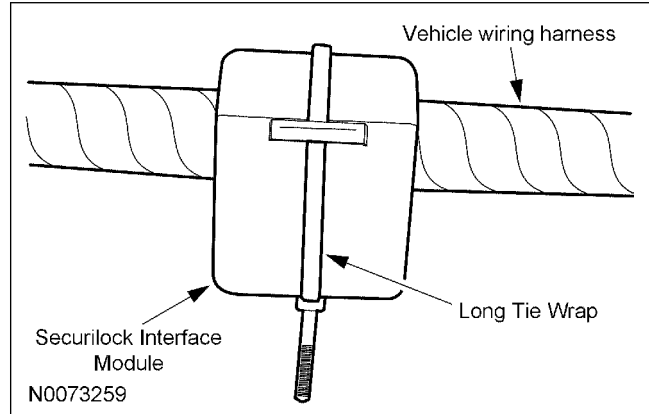
**Install the Remote Start Control Module and Harness Assembly**

24. Place the remote start module and harness assembly on the floor of the vehicle.

**Identify Circuit Wires For Connections**

**NOTE:** For vehicle specific wiring diagram(s) click [here](#).

**NOTE:** For proper wire splicing techniques click [here](#).

25. Connect the Black ground wire from the remote start module harness to the chassis ground point at the driver kick panel.

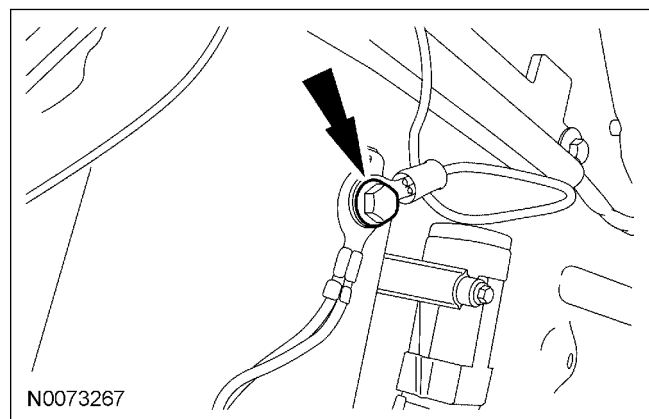

26. Disconnect the ignition switch electrical connector.
27. Connect the remote start harness hard shell connectors to the ignition switch and ignition switch connector.

**INSTALLATION (Continued)**

28. **NOTE:** A DVOM connected to the correct wire will show 12V, then show 0V when the horn button is held.
- A logic probe will show power on the correct wire, then show ground when the horn button is held.
- Identify the Blue/White horn circuit wire in the steering column harness.
29. Connect the Brown/Black wire from the remote start module harness to the Blue/White horn circuit wire in the steering column harness.
30. **NOTE:** Skip this step for MKZ.
- NOTE:** A DVOM connected to the correct wire will show 12V, then show 0V when the door lock switch is pressed.
- A logic probe will show power on the correct wire, then show ground when the door lock switch is pressed.
- Identify the Blue/Green power door lock circuit wire at the driver kick panel harness underneath bright green electrical tape.
31. **NOTE:** Skip this step for MKZ.
- Connect the Blue wire from the remote start module harness to the Blue/Green power door lock circuit at the driver kick panel harness underneath bright green electrical tape.
32. **NOTE:** A DVOM connected to the correct wire will show 0V, then show 12V while depressing the brake pedal.
- A logic probe will show ground on the correct wire, then show power while depressing the brake pedal.
- Identify the looped Violet/White brake switch circuit wire at the driver kick panel harness underneath bright green electrical tape.
33. Connect the Brown wire from the remote start module harness to the looped Violet/White brake switch circuit wire at the driver kick panel harness underneath bright green electrical tape.
34. **NOTE:** A DVOM connected to the correct wire will show 12V with the vehicle door(s) open and the dome light ON, then show 0V with the vehicle door(s) closed and the dome light OFF.
- NOTE:** A logic probe connected to the correct wire will show power with the vehicle door(s) open and the dome light ON, then show ground with the vehicle door(s) closed and the dome light OFF.
- NOTE:** Be sure that the dome light has timed out and is OFF before performing the door closed test.
- Be sure that the dome lamp is illuminated before performing the door open test.
- Identify the looped Gray/Violet dome light circuit wire at the Smart Junction Box (SJB) harness C2280A Pin 9.
35. Connect the Green/Violet wire from the remote start module harness to the looped Gray/Violet dome light circuit wire at the Smart Junction Box (SJB) harness C2280A Pin 9.
36. **NOTE:** Do NOT splice into any circuits leading to the back of the headlight switch. Doing so may lead to headlight switch failure.
- NOTE:** A DVOM connected to the correct wire will show 12V, when the headlight switch is ON, then show 0V when the headlight switch is OFF.
- NOTE:** A logic probe will show power on the correct wire when the headlight switch is ON, then show ground when the headlight switch is OFF.
- Identify the looped Violet/White parking light on circuit wire at the driver kick panel harness underneath bright green electrical tape.
37. Connect the White wire from the remote start module harness to the looped Violet/White parking light on circuit at the driver kick panel harness underneath bright green electrical tape.

**INSTALLATION (Continued)****Install The Hood Safety Switch**

38. **NOTE:** Route the hood safety switch wire carefully avoiding any moving parts or components that can produce excessive heat.

**NOTE:** Using a piece of convolute adds in the appearance of the installation.

**NOTE:** The switch should be positioned about 30 degrees below parallel to the ground to accommodate for parking on inclines.

Failure to position the switch properly could result in one of the following:

- False alarm trips
- Non-Remote Start events
- Inadvertent shutdown during Remote Start

Locate an easy to access area near the driver side hood hinge and install the hood safety switch using the supplied metal screws.

39. Apply rustproofing compound (PM-13-A) to the drilled hole and torque the screw to 1.00 Nm (10 lb-in).

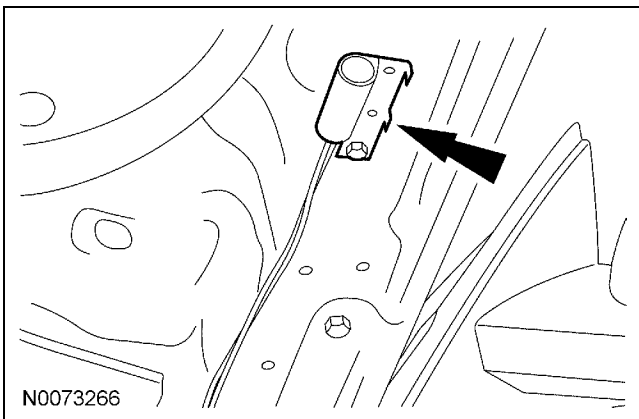

40. Connect hood switch ground wire to a suitable location on the bulkhead.

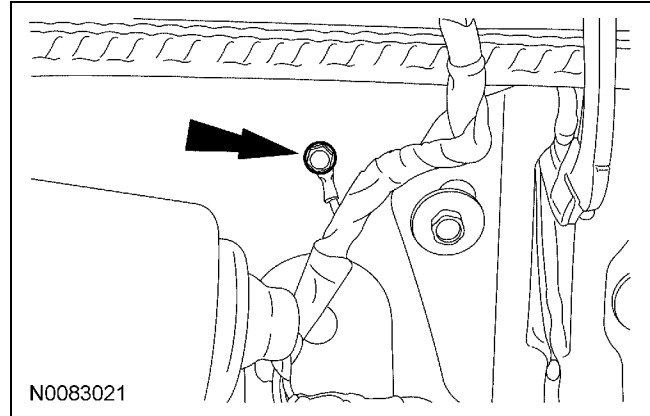

41. **NOTE:** Place the label on the radiator fan shroud or similar area.

Install the underhood warning label

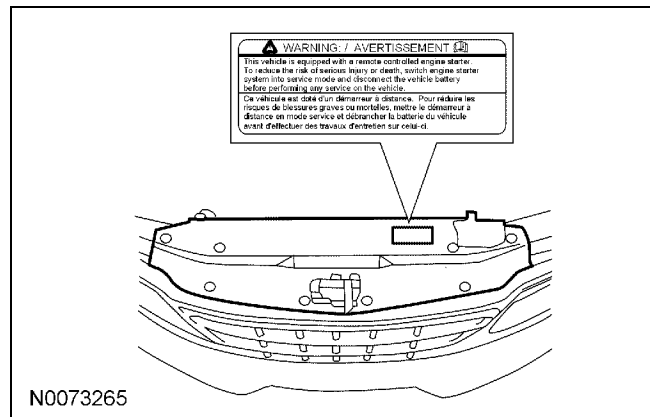

42. Route the Gray hood safety switch wire through the bulkhead into the engine compartment and attach to the hood safety switch.

43. Connect the antenna to the RMST control module.

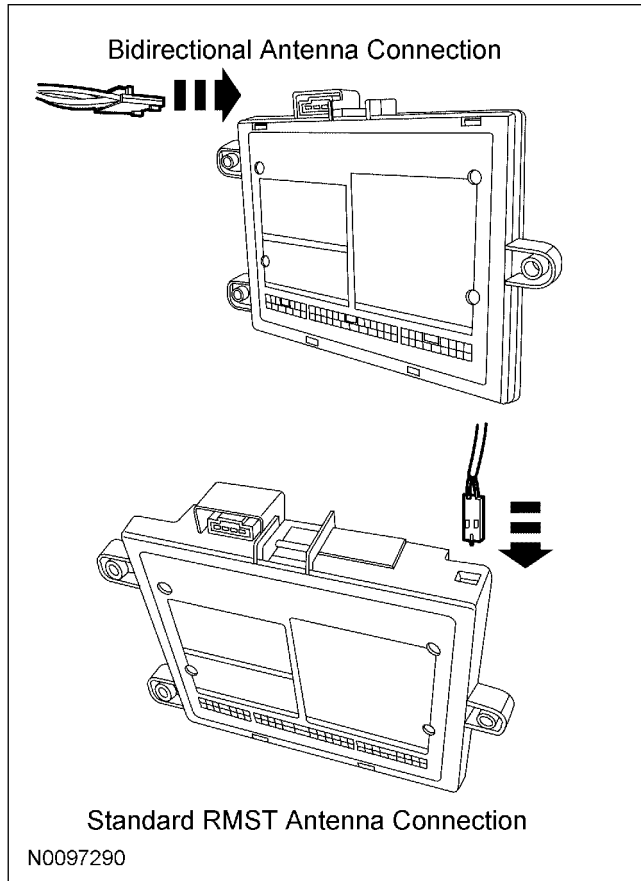
**INSTALLATION (Continued)**

44. Connect the SECURILOCK interface module to the RMST control module.

**Program The RMST System**

45. Refer to the RMST programming section for this vehicle [click here](#).

**Secure RMST Harness and Control Module**

46. Use the supplied tie wraps to secure the RMST harness wires.
47. **NOTE:** Do not mount the control module in the knee bolster area.
- Secure the control module at three points to the vehicle.
- Use the supplied long tie wraps to mount the RMST control module to the underdash wiring harness.

**Install Trim**

48. Install the left hand scuff plate and cowl trim panel.
49. Install the lower steering column shroud.  
Install the 3 screws.
50. Install the upper steering column shroud.
51. Install the instrument panel steering column cover by pushing straight inward.

## GENERAL PROCEDURES

### Programming - Standard Remote Start

#### Programming the Module

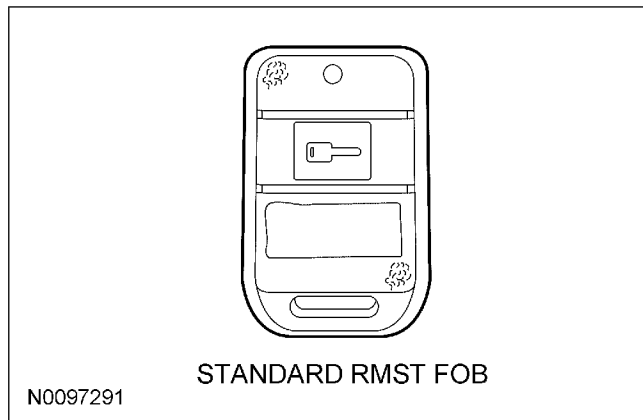

- NOTE:** If the remote start options (Key-in sense polarity, door ajar polarity, or tach mode) are not programmed correctly, vehicle will not remote start or operate properly.

**NOTE:** Make sure that the hood and doors are closed before proceeding.

**NOTE:** The LED on the remote start harness must be visible to complete module programming.

**NOTE:** The remote start override button must be accessible.

#### Programming Options: Entering Programming Mode

- See chart below for programming information.

#### Program Bank 2 Chart (5 Honks)

BANK	OPTIONS	DESCR	LED
2	1	TACHLESS MODE	ON

- Press and hold the brake pedal.
- Turn the ignition key to the RUN position.  
The dome light will turn off.

- Press and hold the remote start system override button for at least 10 seconds.

After 10 seconds the horn will honk 3 times, indicating the system is now in the learn mode.

Release the brake pedal and the RMST override button.

- Press and release the override button. The horn will honk 4 times indicating the system has entered the first program bank.

If not, please check the following:

- Brake pedal switch wire solder connection.
- Hood closed and Grey hood safety switch wire solder connection.
- All doors closed and dome light circuit wire solder connections.
- The key is in the RUN position.
- The software cartridge is firmly seated in the RMST module.
- The RMST harness connections are firmly seated in the RMST module.

**NOTE:** If you require additional assistance: CALL 1-800-FORD KEY.

- Press and release the override button again. The horn will honk 5 times indicating the system has entered the second program bank.
- Press and release the brake pedal.  
The horn will honk 1 time indicating the system has entered the option 1 of the second program bank.

**NOTICE:** When turning LED on or off using remote start fob button quickly press and immediately release the remote start button.

**Failure to quickly release the remote start fob button will result in system defaulting to the factory options.**

- The LED must be on for option 1. If the LED is illuminated no action is required. If the LED is not illuminated press the remote start fob button and verify the LED illuminates.



**GENERAL PROCEDURES (Continued)**

**NOTE:** If the remote start fob button is held for more than 3 seconds the system will chirp the horn 4 times, indicating the system has returned to factory default settings. If this occurs return to step 1 of the programming section and reprogram the remote start module.

**NOTE:** The remote start module is now programmed.

10. Remove the ignition key.

**Programming the SECURILOCK**

**NOTE:** Two PATS keys are required to program the SECURILOCK.

**NOTE: IMPORTANT:** Each of the following steps should be completed with no more than 5 seconds delay between steps.

11. Insert the first ignition key and turn to the run position.

Watch for the PATS light to turn off. Remove the first key.

12. Insert the second ignition key and turn to the run position.

Watch for the PATS light to turn off. Remove the second key.

13. Press and hold the remote start button



for 3 seconds.  
The PATS light should stay on for 3-5 seconds before turning off, which means that the SECURILOCK was successfully programmed.

**NOTE:** If the PATS light blinks rapidly, repeat steps 1-3 to retry programming the SECURILOCK.

**NOTE:** The engine will start if the Remote Start kit has been installed correctly, the brake is not depressed, and the hood and doors are closed.

## GENERAL PROCEDURES

### Functional Test - Standard Remote Start

**NOTE:** If during any of the steps of the functional test, the remote start system or vehicle doesn't react or perform accordingly, please refer to the remote start troubleshooting guide.

**NOTE:** For remote start troubleshooting guide click [here](#).

1. Make sure all doors are closed but hood is open and windows are down (doors will be locking).
2. Press and hold the Start button on the remote control key fob for 2-3 seconds - Horn should honk once indicating receipt of the start request.
3. The remote start systems should turn on the ignition, but then honk the horn twice and shut down indicating the hood is open.
4. Close the hood, and insert a key into the ignition switch.
5. Attempt to re-start the vehicle again using the key fob.
6. The remote start systems should turn on the ignition, but then honk the horn five times and shut down indicating a key is in the ignition switch.
7. Remove the key and open a door.
8. Attempt to re-start the vehicle again using the key fob.
9. The remote start systems should turn on the ignition, but then honk the horn three times and shut down indicating a door is open.
10. Close the door.
11. Attempt to re-start the vehicle again using the key fob.
12. Once the vehicle starts, verify that all radio, heat, and A/C functions operate normally and that the doors have locked.
13. On vehicles equipped with power window interrupt, Attempt to close windows to check power window interrupt function.
14. Once all systems have been checked, press the brake pedal - the remote start systems should shut down.

### Troubleshooting

15. **NOTE:** When attempting to remote start your vehicle, the system has several safety checks that it performs. If any of these inputs are present that should not be, the system will respond back to you with several horn "chirps" to help you identify which input is present. These "chirps" will occur after initiating a start sequence with the transmitter, the system will turn on the ignition, but then respond back with several horn "chirps" and abort the starting process.

**Example:** Depress the remote start fob button for 3 seconds and then release. The vehicle horn will "chirp" one time to indicate that RMST signal was received. If the vehicle doesn't start and the horn "chirps" 3 times, there is a fault - "Vehicle Door is Open"

CHIRPS	PROBLEM
1 Chirp	SECURILOCK not programmed correctly, or the SECURILOCK antenna ring is damaged.
2 Chirps	BRAKE is being pressed, or the HOOD is open.
3 Chirps	One of the vehicles DOORS are open.
4 Chirps	TACH not programmed.

**GENERAL PROCEDURES (Continued)**

---

<b>CHIRPS</b>	<b>PROBLEM</b>
5 Chirps	The KEY is in the ignition.
6 Chirps	The remote start system is in SERVICE/VALET mode.

---

## GENERAL PROCEDURES

### Programming - Bidirectional Remote Start

#### Programming the Module

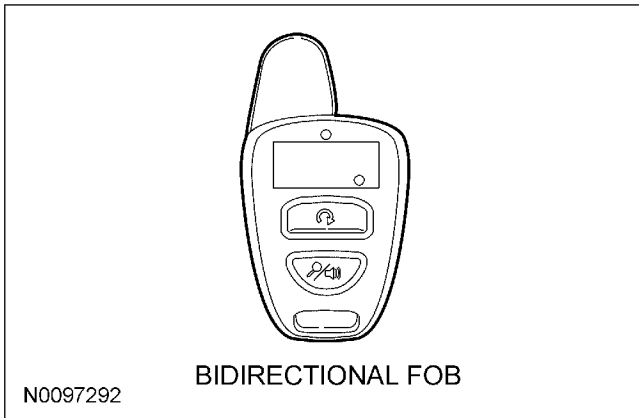

- NOTE:** If the remote start options (Key-in sense polarity, door ajar polarity, or tach mode) are not programmed correctly, vehicle will not remote start or operate properly.

**NOTE:** Make sure that the hood and doors are closed before proceeding.

**NOTE:** The LED on the remote start harness must be visible to complete module programming.

**NOTE:** The remote start override button must be accessible.

#### Programming Options: Entering Programming Mode

- See chart below for programming information.

#### Program Bank 2 Chart (5 Honks)

BANK	OPTIONS	DESCR	LED
2	1	TACHLESS MODE	ON

- Press and hold the brake pedal.
- Turn the ignition key to the RUN position.  
The dome light will turn off.

- Press and hold the remote start system override button for at least 10 seconds.

After 10 seconds the horn will honk 3 times, indicating the system is now in the learn mode.

Release the brake pedal and the RMST override button.

- Press and release the override button. The horn will honk 4 times indicating the system has entered the first program bank.

If not, please check the following:

- Brake pedal switch wire solder connection.
- Hood closed and Grey hood safety switch wire solder connection.
- All doors closed and dome light circuit wire solder connections.
- The key is in the RUN position.
- The software cartridge is firmly seated in the RMST module.
- The RMST harness connections are firmly seated in the RMST module.

**NOTE:** If you require additional assistance: CALL 1-800-FORD KEY.

- Press and release the override button again. The horn will honk 5 times indicating the system has entered the second program bank.
- Press and release the brake pedal.  
The horn will honk 1 time indicating the system has entered the option 1 of the second program bank.

**NOTICE:** When turning LED on or off using remote start fob button quickly press and immediately release the remote start button.

**Failure to quickly release the remote start fob button will result in system defaulting to the factory options.**

- The LED must be on for option 1. If the LED is illuminated no action is required. If the LED is not illuminated press the remote start fob button and verify the LED illuminates.

**GENERAL PROCEDURES (Continued)**

**NOTE:** If the remote start fob button is held for more than 3 seconds the system will chirp the horn 4 times, indicating the system has returned to factory default settings. If this occurs return to step 1 of the programming section and reprogram the remote start module.

**NOTE:** The remote start module is now programmed.

10. Remove the ignition key.

**Programming the SECURILOCK**

**NOTE:** Two PATS keys are required to program the SECURILOCK.

**NOTE: IMPORTANT:** Each of the following steps should be completed with no more than 5 seconds delay between steps.

11. Insert the first ignition key and turn to the run position.

Watch for the PATS light to turn off. Remove the first key.

---

12. Insert the second ignition key and turn to the run position.

Watch for the PATS light to turn off. Remove the second key.

13. Press the remote start button  twice within 3 seconds.

The PATS light should stay on for 3-5 seconds before turning off, which means that the SECURILOCK was successfully programmed.

**NOTE:** If the PATS light blinks rapidly, repeat steps 1-3 to retry programming the SECURILOCK.

**NOTE:** The engine will start if the Remote Start kit has been installed correctly, the brake is not depressed, and the hood and doors are closed.

## GENERAL PROCEDURES

### Functional Test - Bidirectional Remote Start

**NOTE:** If during any of the steps of the functional test, the remote start system or vehicle doesn't react or perform accordingly, please refer to the remote start troubleshooting guide.

**NOTE:** For remote start troubleshooting guide click [here](#).

1. Make sure all doors are closed but hood is open and windows are down (doors will be locking).
2. Press the Start button on the remote control key fob twice within 3 seconds - Horn should honk once indicating receipt of the start request.
3. The remote start systems should turn on the ignition, but then honk the horn twice and shut down indicating the hood is open.
4. Close the hood, and insert a key into the ignition switch.
5. Attempt to re-start the vehicle again using the key fob.
6. The remote start systems should turn on the ignition, but then honk the horn five times and shut down indicating a key is in the ignition switch.
7. Remove the key and open a door.
8. Attempt to re-start the vehicle again using the key fob.
9. The remote start systems should turn on the ignition, but then honk the horn three times and shut down indicating a door is open.
10. Close the door.
11. Attempt to re-start the vehicle again using the key fob.
12. Once the vehicle starts, verify that all radio, heat, and A/C functions operate normally and that the doors have locked.
13. On vehicles equipped with power window interrupt, Attempt to close windows to check power window interrupt function.
14. Once all systems have been checked, press the brake pedal - the remote start systems should shut down.

### Troubleshooting

15. **NOTE:** When attempting to remote start your vehicle, the system has several safety checks that it performs. If any of these inputs are present that should not be, the system will respond back to you with several horn "chirps" to help you identify which input is present. These "chirps" will occur after initiating a start sequence with the transmitter, the system will turn on the ignition, but then respond back with several horn "chirps" and abort the starting process.

**Example:** Depress the remote start fob button for 3 seconds and then release. The vehicle horn will "chirp" one time to indicate that RMST signal was received. If the vehicle doesn't start and the horn "chirps" 3 times, there is a fault - "Vehicle Door is Open"

CHIRPS	PROBLEM
1 Chirp	SECURILOCK not programmed correctly, or the SECURILOCK antenna ring is damaged.
2 Chirps	BRAKE is being pressed, or the HOOD is open.
3 Chirps	One of the vehicles DOORS are open.
4 Chirps	TACH not programmed.
5 Chirps	The KEY is in the ignition.
6 Chirps	The remote start system is in SERVICE/VALET mode.

# '11 Fusion/Milan/MKZ/Hybrid

## TYPE "A" CUSTOM WIRE HARNESS

### RMST MODULE WIRE HARNESS

#### STEERING COLUMN HARNESS

	Color	Function
A-3	PINK	Ignition Input/Output
A-2	ORANGE	HVAC Output
A-13	VIOLET	Starter Output
B-8	BLACK/WHITE	Key-in-sense Input
A-4	RED	Battery

	Color	Function
A-21	BROWN/BLACK	Horn Relay Output

#### DRIVER'S KICK PANEL HARNESS

	Color	Function
A-5	BLACK	Ground
A-24	BLUE	Door Lock Output
B-7	BROWN	Brake Input
A-1	WHITE	Parking Light Output
A-20	GREEN/VIOLET	Door Ajar Switch Input

#### UNDER HOOD HARNESS

	Color	Function
A-19	GRAY	Hood Open Switch Input

Vehicle Interior      Engine Compartment

VEHICLE HARNESS

IGNITION SWITCH

Horn (BLUE/WHITE)

STEERING COLUMN HARNESS

**MAKE THIS CONNECTION FIRST!**

CHASSIS GROUND POINT IN DRIVER SKICK PANEL

\*\* (Fusion/Milan only) Door Lock (BLUE/GREEN)

DRIVERS KICK PANEL

\*\* Brake (VIOLET/WHITE)

\*\* LOOPED CIRCUIT UNDER BRIGHT GREEN TAPE

\*\* Parking Lights On (VIOLET/WHITE)

SMART JUNCTION BOX (SJB) C2280A Pin 9

Dome Light (GRAY/VIOLET)

Hood Tilt Switch

Chassis Ground

Do Not Ground to Hood!

\*\* = All The Starred Items Should Be Grouped Together (Same Location).