

Real-Time Digital Simulator Enabled Hardware-in-the-Loop Electric Machine Drive Lab

Hossein G. Aghamolki and Zhixin Miao
Department of Electrical Engineering
University of South Florida, Tampa, FL 33620
Email: zmiao@usf.edu

Abstract—This paper presents real-time digital simulator enabled hardware-in-the-loop (HIL) electrical machine drive lab setup for educational purposes. The objective of this work is to create a platform for laboratory experiments to enhance drive control design and testing. In the proposed setup, an OPAL-RT real-time digital simulator (RT-LAB) is used to implement the desired control schemes for AC and DC electric machine drives. Control blocks are created in Matlab/Simulink while measurement signals from the motors are taken into Matlab/Simulink through RT-LAB I/O interface. RT-LAB software compiles the MATLAB code to C code and downloads it to OP-4500 OPAL-RT simulator through network connections. PWM signals are then generated by OP-4500 I/O board and sent to an power electronic board to drive a DC or AC machine.

I. INTRODUCTION

Development in new technologies and lower cost for new hardware and personal computers as well as a variety of software packages leads to changes in engineering laboratories. With these new development in hardware/software technologies, new techniques in data acquisition and communication, computer simulation, and hardware interfacing are introduced [1]. In this paper, we will describe the drive lab setup using real-time digital simulator.

Electric drive experiments in machine drive laboratory are designed to help students understand electric machine drive fundamentals. By applying different control algorithms for AC and DC machines drive through such experiments, students are given enough experience and knowledge they need to prepare them for real-world industrial jobs. Implementing different control algorithms in lab is not easy because of the high cost of machines and control devices. Computer simulation gives students knowledge and visual experience about modeling and operation aspects of electric drive, without being in contact with real electric drives. USF's power program has used computer simulation software PSCAD and Matlab/SimPowersystems extensively in teaching. For example, [2], [3] are two course projects developed in the Power Electronics class where PSCAD and Matlab/SimPowersystems are used for simulation of power electronic converters.

This paper documents the new HIL drive lab setup at USF. Development in hardware and software technology, specially in real-time simulation and HIL technology, makes it possible to develop new laboratory setup using real-time digital simulators and cheap power electronic boards in order to design and

implement different control algorithms for electric machine drives.

HIL is a technique for developing and testing of control systems for operation of complex machines and power grids. With HIL simulation, either the control systems or the physical part of a machine or power system can be replaced by real-time simulation. In another word, HIL is the simulation of either the controller or the plant [4]. Real-time simulation refers to computer simulation that can achieve the same speed as that of the physical system. For example, in real-world, voltage and current frequency is 60 Hz. OPAL-RT can run a simulation model and generate voltage and current signals of 60 Hz. With this capability, real-time digital simulators are employed to interface with hardware. Recently, real-time simulator enabled HIL test beds have been widely used to facilitate developing laboratory experiments. Real-time digital simulator (RTDS) and OPAL-RT devices are the most common digital real-time simulators used for research platforms and laboratory experiments. RTDS is used in [5] and [6] to implement and validate over-current, distance, and differential protection schemes.

OPAL-RT's real-time simulator is a high performance computer device which can simulate power systems in MATLAB/Simulink and send results to industrial displays and programmable logic controllers (PLC) via digital and analog I/O cards. Using MATLAB/Simulink as a computer language will allow users to quickly create real-time simulation. This type of simulation has also been adopted for power electronic related research at USF, e.g., [7]. Digital and analog I/O cards allow the device to send the physical signals to real hardware. The real device under test is connected to the simulator that runs the electric circuit using analog and digital I/O signals that transmit signals with low power level. This concept has been extended to power components that require high power flows between the real component and the simulated electric circuit running on the simulator [8].

In recent years, dSPACE is used to setup electrical machine drive tests. In [9], University of Minnesota came up with a new design for electric drive laboratory using dSPACE and a power electronic board. dSPACE controller board is designed to run and execute control algorithms, generate necessary PWM signal through its I/O ports, and send command signals to IGBT switches on the power electronic boards. The control block algorithms are coded by dSPACE software and the object

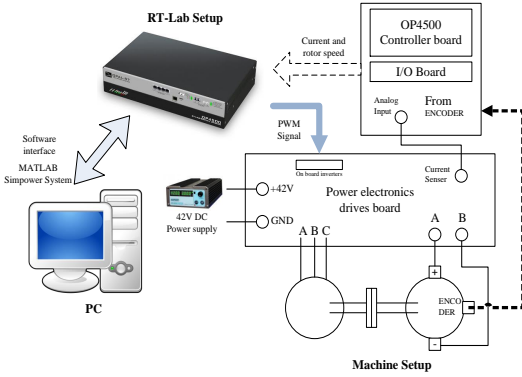

(a) HIL setup structure for machine drive experiments.

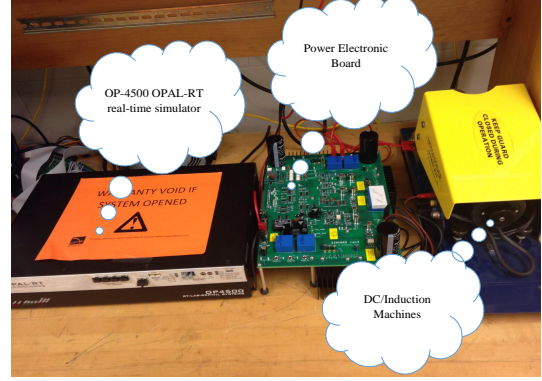

(b) HIL setup for machine drive experiments at USF.

Fig. 1: HIL setup structure for machine drive laboratory.

code is downloaded into the dSPACE board. [10] suggests several electrical machine drive laboratory experiments using such HIL setup. The same hardware setup is used in [11] to achieve a laboratory setup in order to teach induction motor drives.

This paper presents a real-time simulator enabled HIL setup for electric machine drive laboratory. In this setup, OPAL-RT real-time simulator is used to implement the desired control schemes for AC and DC electrical machine drives. Control blocks and measurement signals are created with MATLAB/Simulink. RT-LAB software compiles MATLAB code to C code and downloads it to OP-4500 OPAL-RT simulator through network connection. PWM signals are generated by OP-4500 I/O boards and then sent to power electronic boards to drive DC or AC machines. The experimental setup is modeled after the one proposed by the University of Minnesota [10]. However, the model is modified and the controllers are re-designed in order to be executed in the RT-LAB environment.

The paper is organized as follows: in section II, the proposed setup for machine drive laboratory is discussed. Then two examples: DC drive control and volt-hertz control of induction machine, are presented in section III and section IV respectively. Finally, section V presents conclusion.

II. HIL ELECTRICAL MACHINE DRIVE LABORATORY SETUP

Each machine drive HIL setup is built with one OPAL-RT real-time simulator, one PC equipped with RT-LAB and Matlab/Simulink software, one power electronics drive board and two electric motors. The host PC which works as a command station and acts as the interface between a user and an OPAL-RT simulator. The PC is equipped with RT-Lab software. RT-LAB is an industrial open and scalable real-time platform for engineers. RT-LAB calls MATLAB/Simulink to access dynamic systems built in MATLAB/Simulink. RT-LAB gives flexibility to be applied to the most complex simulation and control problem, whether it is for real-time HIL applications or for dramatically speeding up simulation

execution [8]. Using RT-LAB software on PC as a command station allows users to edit and modify models, to view model data, to execute the model, to convert the model into C code and compile the code, and load the code into the target simulator (or node).

Fig. 1 shows the structure of HIL setup for the machine laboratory. As shown in the Fig. 1b, OP-4500 OPAL-RT real-time simulator is used as a core of the HIL system. Currently, Machine Lab at University of South Florida is equipped with four OP-4500 OPAL-RT devices. Each OP-4500 device has two 4-core INTEL giga processors and is able to send and receive various digital and analog signals via KINTEX 7 XILINX FPGA I/O card. To generate controlled PWM voltage source, OP-4500 generates various digital control signals to dictate the magnitude and phase of the PWM voltage sources [8]. The generated signals are then sent to a power electronic board using DB-37 optical cables. This board has the capability to generate three independent PWM voltage sources from a constant DC voltage source. Hence, three machines can be controlled independently for independent control of variables at the same time. This board also provides the motor phase currents and dc-bus voltage to control the motor for a desired speed or torque.

All the models and control algorithms are simulated in MATLAB/Simulink. RT-LAB software will call the MATLAB/Simulink to execute the model and convert the separated models into C code for compilation as subsystem simulations on each target processor. The converted model will be downloaded to a specified target (OPAL-RT simulator) by RT-Lab software through the network connection using TCP protocol and defining the corresponding IP address of the target. Then the model will be executed on the target and output signals will be generated by digital and analog I/O cards. The HIL setup includes one power electronics board, one induction machine and one dc machine. For some experiments, an induction machine can be replaced by a permanent magnet synchronous machine (PMSM).

As shown in Fig. 4, OPAL-RT system requires two subsystems to execute any model. The main computational element which does not require any real-time change and the I/O board

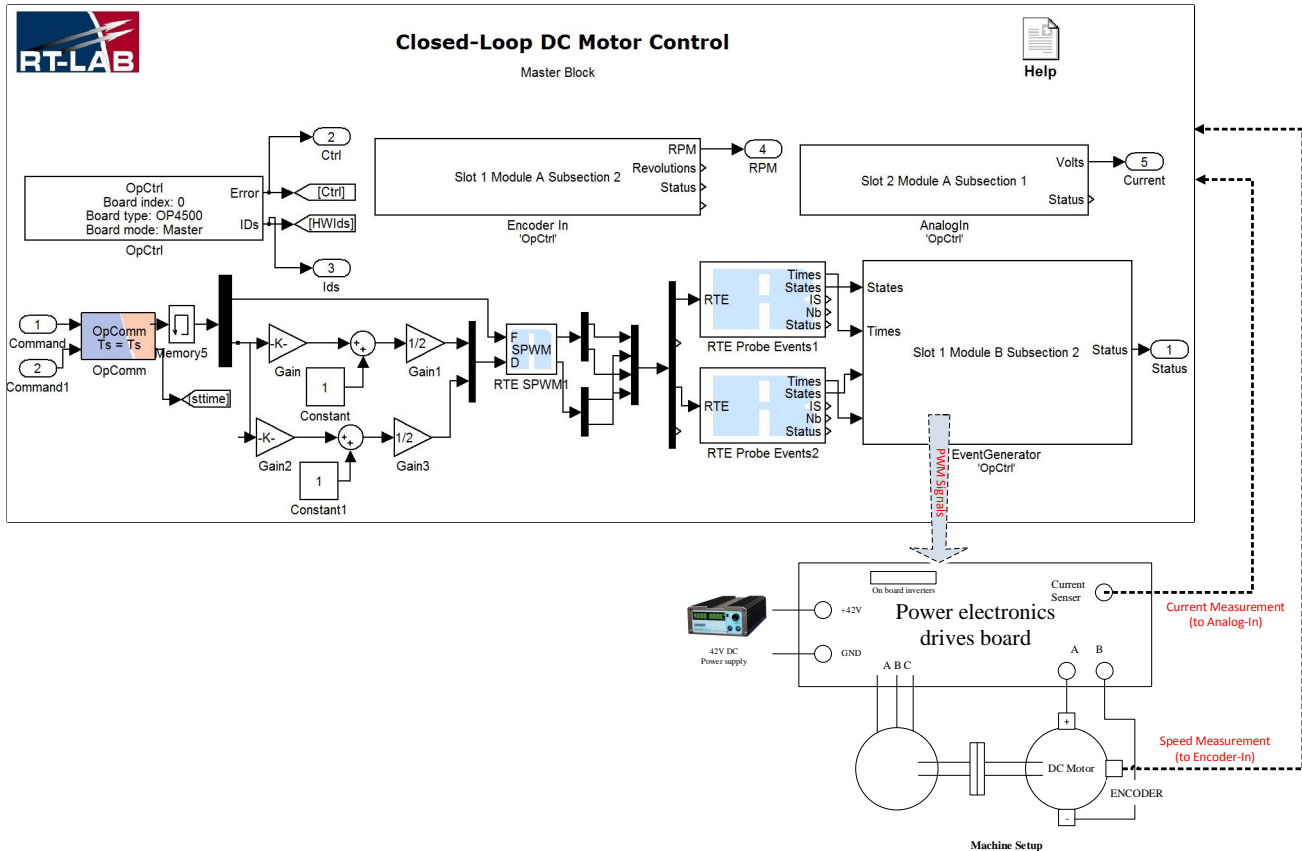

Fig. 2: Opal-RT master block model for closed-loop speed control of DC motor.

blocks are always kept in the master block, while operating command and variables, which have to be changed during real-time simulation are contained in the console subsystem. Furthermore, console subsystem contains the Simulink blocks related to displaying measurements and status data of the system.

A 42V DC power supply is connected to the power electronic board as the power source of the on board inverters. The rotors of the two motors are coupled, so they share the same rotor speed and the speed of the rotor is measured by a optic encoder. In order to implement closed-loop speed control, encoder measurement will be sent back to the Opal-RT simulator via digital input of the I/O board. Also, the phase current is measured by the on board current sensors and measured signal will be sent to the simulator via analog input port. Proposed setup for machine drive gives flexibility to design and implement many algorithms and experiments in the machine drive laboratory. However, since this paper is focused on the setup of the machine lab not its experiments, next sections describe only two examples of such experiments.

III. CLOSED-LOOP SPEED DC MOTOR DRIVE EXPERIMENT

The objective of this experiment is that student use their theoretical knowledge to implement closed-loop speed control on DC machine. Generally there are three most common

method for DC machine speed control, which are field current control for adjusting machine's flux, adjustment of the armature circuit's resistance and adjustment of the armature terminal voltage. In field current control method for motors with shunt field winding, field current can be changed by changing variable resistance in series with shunt field, while in separately excited motor, it can be changed by using power electronic switching. However, in this method, changing field current causes change in flux which directly changes the torque of DC machine. Therefore, torque has its highest value in maximum allowable field current which is occurs in low speed. So, this method is best suited to drives requiring torque at low speed. In armature resistance control method, speed reduction is obtained by adding external series resistance in the armature circuit. Since speed depends on the voltage drop on resistance, in this method, changing the load and hence the currents demand of the load causes significant change in speed. Therefore, a significant disadvantage of this method is the power loss in control system, specially when the speed greatly reduced. [12]

Based on above discussion, armature voltage control is used in USF machine laboratory for driving DC machine. Armature voltage control can be rapidly implemented by using power electronic boards and DC/DC converters. Changing armature voltage of a shunt motor causes direct change in speed voltage, since the voltage drop on armature resistance is relatively

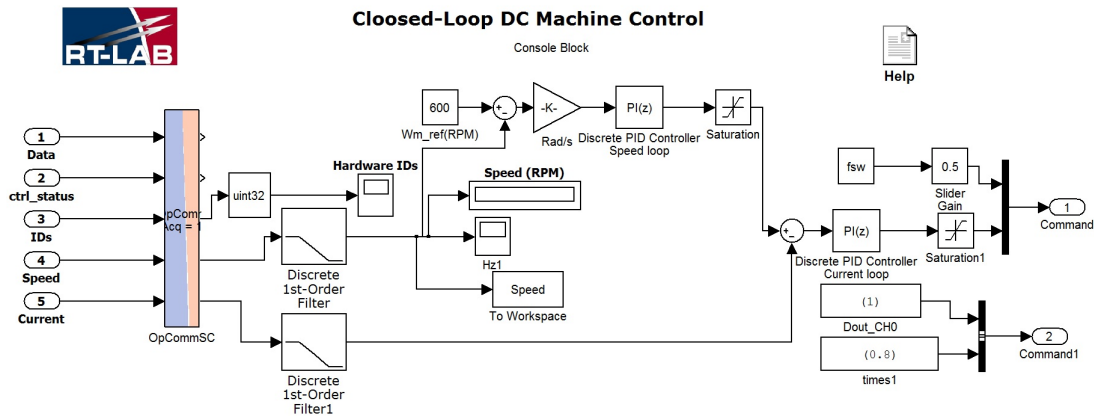

Fig. 3: Opal-RT console block model for closed-loop speed control of DC motor.

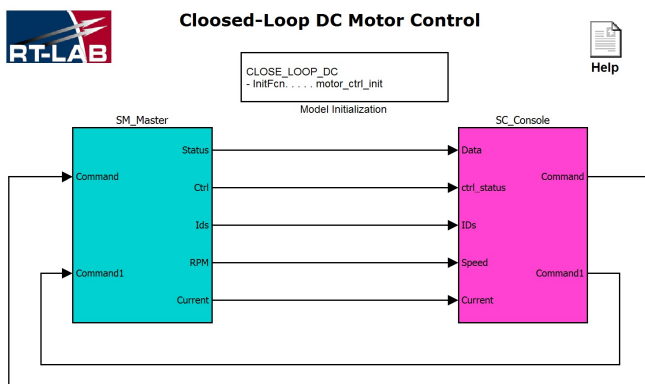

Fig. 4: Opal-RT model for closed-loop speed control of DC motor

small. Because of constant field current and hence constant flux, change in speed voltage will be accompanied by proportional change in speed of the motor. Therefore, by controlling the armature terminal voltage with power electronic boards, we can control the speed of DC machine. To implement desired voltage on the armature terminal of DC machine, H-bridge converter with four IGBTs are used.

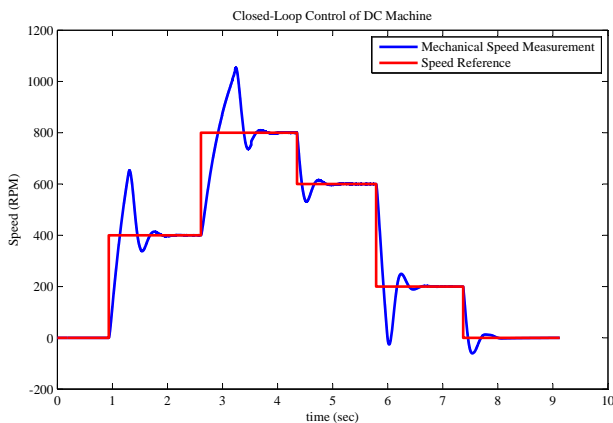

Fig. 5: Results for implementing closed-loop speed control on DC motor

Figures 2 and 3 show the Simulink model for closed-

loop speed control of DC Machine in RT-Lab. In Fig. 2, calculation the duty cycle of IGBTs are contained in master subsystem. Event-Generator blocks which generate PWM signals in digital out port, Encoder-In block which reads the speed measurement from encoder and Analog-In block which capture current measurement from power electronic board's current sensors are also contained in master subsystem. In proposed simulation model, the magnitude of the voltage came from speed control loop, together with desired switching frequency are sent to master. In RT-LAB, OpComm blocks are used to enable and save communication setup information. All inputs to top-level subsystems must first go through an OpComm block before they can be used [8]. Based on the voltage magnitude duty cycle for each switch are calculated in the model. Although In proposed model, Event generator block used to create PWM signals, it is possible to used PWM-Out block for creating the required signals too.

Fig. 3 shows the console subsystem blocks. DC machine control system is consist of two feedback loops. The inner loop related to the current feedback while the outer loop is speed feedback. In both loops, the reference value and measurement feedback value are compared and the error is compensated using two PI controller blocks. In order to protect machine from over currents, each loop output is limited by saturation blocks. The voltage magnitude calculated in speed control loop and desired switching frequency are sent to the master subsystem. Fig. 5 presents the proposed model results collected in real-time implementation of closed-loop control. As it is shown in the figure, five step change applied to the speed reference of control system. Speed response shows that PI controller design was able to track the reference speed within a reasonable response time and without any steady state error.

IV. INDUCTION MACHINE VOLT/HERTZ CONTROL

Open-loop Volt/Hertz control of induction machine is one of the several scalar speed control techniques. This method is the most popular speed control of IM with VSC converters. The easiest method For controlling the speed of IM is to change stator voltage's frequency. However, if we neglect stator resistance voltage drop, based on flux relation with

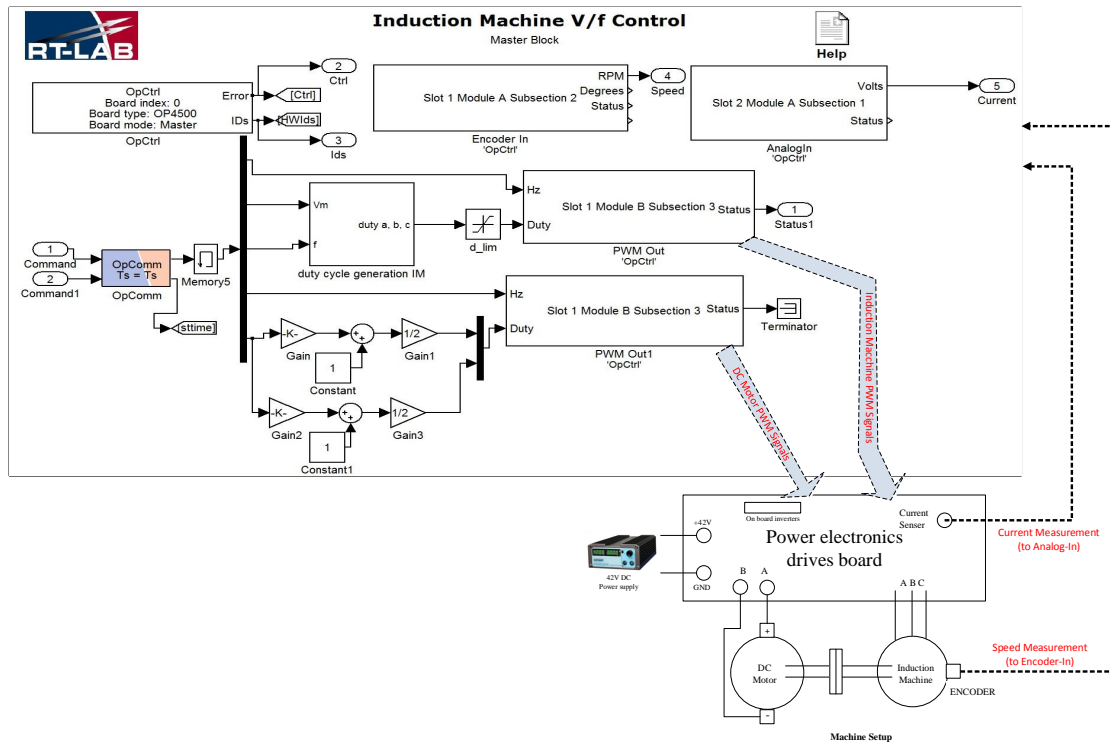

Fig. 6: Opal-RT Master block model for V-f control of induction machine

speed and voltage ($\lambda = \frac{V_s}{2\pi f_s}$), with changing frequency, flux magnitude will be change too. Indeed, if an attempt is made to reduce the frequency at the rated stator voltage, the flux will tend to saturate, causing excessive stator current and distortion of the flux waveforms [13]. Therefore, changing the frequency have to be accompanied with the change in stator voltage magnitude. In the other words, by keeping voltage-frequency ratio constant, the flux will be maintain on its rated value. Fig. 7 shows the torque-speed curves. It can be shown in this figure that in the region below the base frequency, the torque-speed curves are identical to each other and that the maximum torque is preserved regardless of the frequency [13].

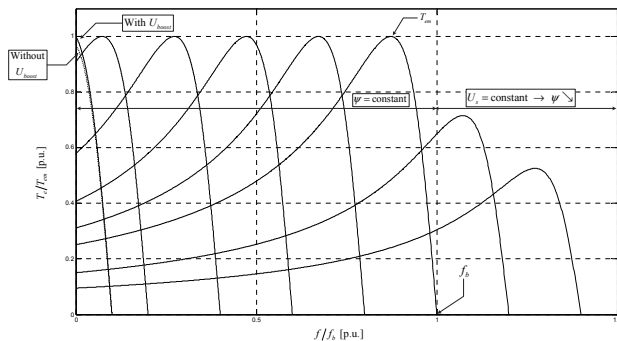

Fig. 7: Torque-speed curves at constant Volts/Hz region and in flux-weakening region [13].

Fig. 6 presents proposed model for master subsystem of RT-Lab. As it can be seen, frequency and magnitude of the stator's voltage is used as inputs for the duty cycle generation block. In this model, two different digital PWM-out ports are used

for generating PWM signals for IM and DC machine. Also, Encoder-In and Analog-In blocks are used to read the speed and current measurement respectively. In this experiment, students are asked to estimate number of poles of IM and to observe voltage-frequency relation of the machine.

Fig. 8 shows console subsystem of RT-LAB. By neglecting the slip, frequency can be assumed equal to speed. So the main variable of speed control technique is frequency. The second variable is stator voltage magnitude which is directly calculated from reference frequency. Since in this experiment, DC machine is used as mechanical load/primover, the control blocks for DC machine can be seen in console subsystem. The desire frequency and voltage of IM, together with desire switching frequency is sent to master subsystem.

Fig. 9 shows the stator voltage versus its frequency based on the results collected in real-time implementation of Volt-Hertz control on induction machine. If we neglect the nonlinearity caused by the measurement errors, the figure almost shows a linear relationship between stator voltage magnitude and its frequency.

V. CONCLUSION

In this paper, real-time HIL electrical machine drive laboratory setup was investigated. The objective of this work is to create a platform for laboratory experiments to enhance the power system testing and validation schemes as well as better understanding of machine drive systems. This is achieved by integrating different hardware devices and developing communication interface between those devices. HIL setup is build with One Opal-RT real-time simulator, one PC equipped with RT-LAB and Matlab/Simulink software, one

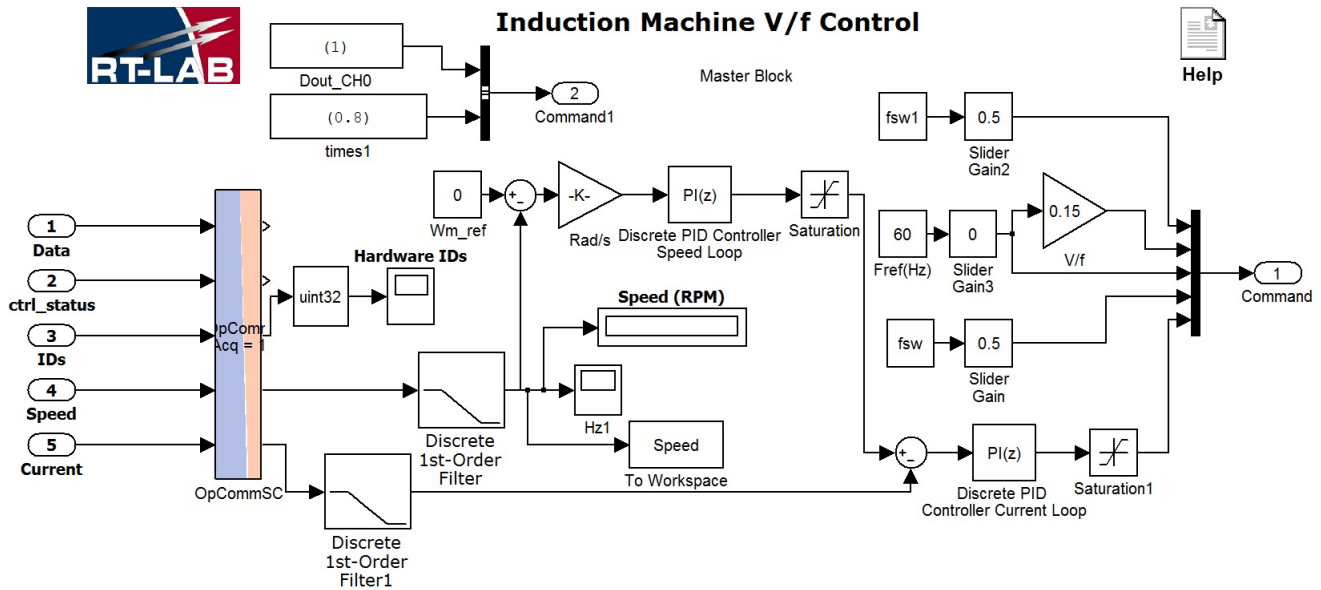

Fig. 8: Opal-RT console block model for V-f control of induction machine

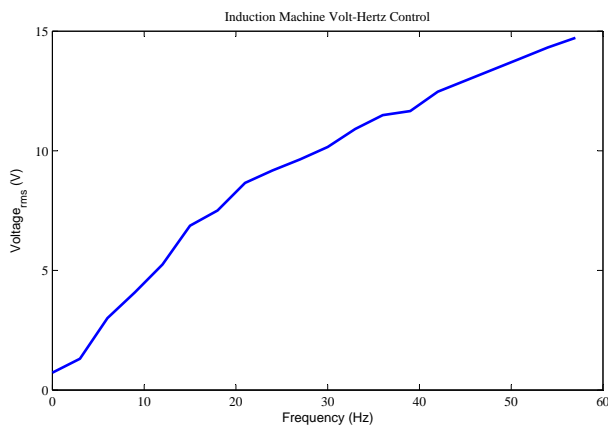

Fig. 9: Voltage-Frequency figure results collected in real-time V/f control implementation

power electronics drives board and two electric motors. In this setup, Opal-RT real-time simulator is used to implement the desired control scheme for AC and DC electrical machine drive. Control blocks and measurement signals are created with Matlab Simulink. RT-LAB software compiles Matlab simulation to C code and downloads it to OP-4500 Opal-RT simulator through network connection. Then, PWM signals are generated by OP-4500 I/O board and command signals are sent to power electronic board to drive DC or AC machine.

REFERENCES

- [1] L. D. Feisel and A. J. Rosa, "The role of the laboratory in undergraduate engineering education," *Journal of Engineering Education*, vol. 94, no. 1, pp. 121–130, 2005.
- [2] Y. Ma, L. Fan, and Z. Miao, "Realizing space vector modulation in matlab/simulink and pscad," in *North American Power Symposium (NAPS), 2013*. IEEE, 2013, pp. 1–6.
- [3] Y. Li, J. Khazaei, L. Fan, and Z. Miao, "Modeling of z-source converter for renewable energy integration," in *North American Power Symposium (NAPS), 2013*. IEEE, 2013, pp. 1–6.
- [4] P. Menghal and A. Laxmi, "Real time control of electrical machine drives: A review," in *Power, Control and Embedded Systems (ICPCES), 2010 International Conference on*, Nov 2010, pp. 1–6.
- [5] E. Schweitzer, D. Whitehead, A. Guzman, Y. Gong, M. Donolo, and R. Moxley, "Applied synchrophasor solutions and advanced possibilities," in *Transmission and Distribution Conference and Exposition, 2010 IEEE PES*, April 2010, pp. 1–8.
- [6] A. Saran, S. Palla, A. Srivastava, and N. Schulz, "Real time power system simulation using rtds and ni pxi," in *Power Symposium, 2008. NAPS '08. 40th North American*, Sept 2008, pp. 1–6.
- [7] J. Khazaei, Z. Miao, L. Piyasinghe, and L. Fan, "Real-time digital simulation-based modeling of a single-phase single-stage pv system," *Electric Power Systems Research*, vol. 123, pp. 85–91, 2015.
- [8] "Distributed real-time power system," in *Opal-RT manuals*, www.opal-rt.com, 2012.
- [9] R. Panaitescu, N. Mohan, W. Robbins, P. Jose, T. Begalke, C. Henze, T. Undeland, and E. Persson, "An instructional laboratory for the revival of electric machines and drives courses," in *Power Electronics Specialists Conference, 2002. pesc 02. 2002 IEEE 33rd Annual*, vol. 2, 2002, pp. 455–460 vol.2.
- [10] N. Mohan, "Dsp based electric drives laboratory user manual," in *Department of Electrical and Computer Engineering, University of Minnesota*, July 2007.
- [11] P. Ponce, M. Pacas, and A. Molina, "Real time systems for teaching induction motor drives," in *e-Learning in Industrial Electronics (ICELIE), 2012 6th IEEE International Conference on*. IEEE, 2012, pp. 65–73.
- [12] S. D. Umans, *Fitzgerald and Kingdley's Electric Machinery*. McGraw-hill New York, 2014, vol. 7.
- [13] B. K. Bose, *Power electronics and motor drives: advances and trends*. Academic press, 2010.