

# OPC DAY FINLAND 2017

11.10.2017 #OPCUA #OPCDAYFINLAND #AUTOMATION #OPCDAY

# Real world OPC-UA use cases

Héctor García

Channel Manager, Europe - Kepware

October 2017



FINNISH SOCIETY OF AUTOMATION  
SUOMEN AUTOMAATIOSEURA RY

## SPONSORS

**BECKHOFF**



NESTEJACOBS



# CONTENTS

- About Kepware
- KEPServerEX® - Universal Communications Platform
- Real world KEPServerEX® use cases
- Resources and Services

# About Kepware Technologies

# PROSPECTUS



Established in  
**1995**



Located in  
**Portland, Maine**



**20+ YEARS**  
of developing connectivity  
software for the **Industrial  
Automation** Industry

Extending PTC's reach  
in Manufacturing with  
**industrial connectivity  
solutions** for the IoT

## Strong History of Growth and Expansion

Industries  
Served



Manufacturing



Oil & Gas



Building Automation



Power



IT & Infrastructure

**NOVOTEK**

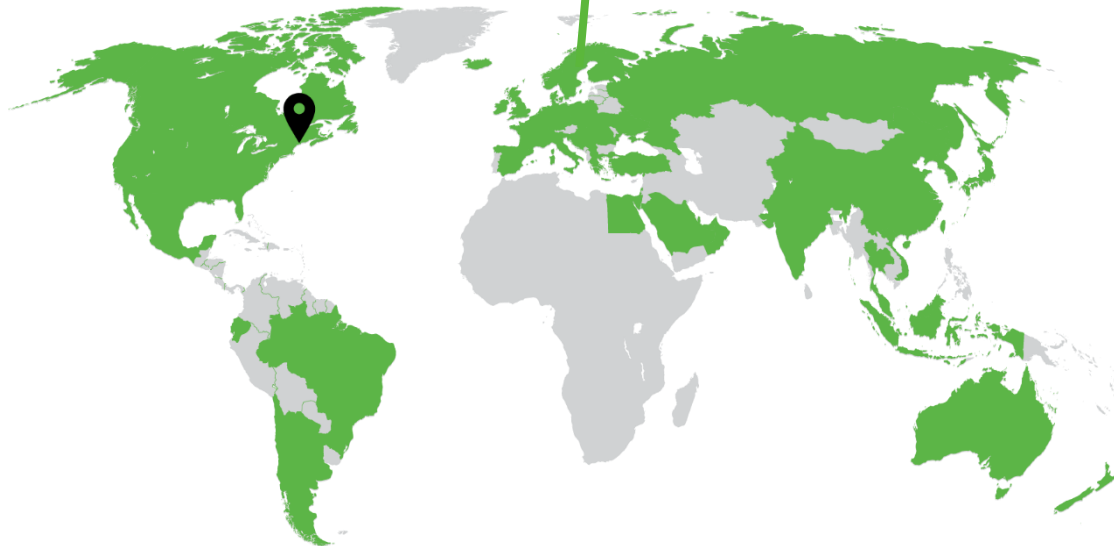

# KEPServerEX® Universal Communications Platform

# BUT MODERN COMMUNICATIONS ARE MORE DEMANDING

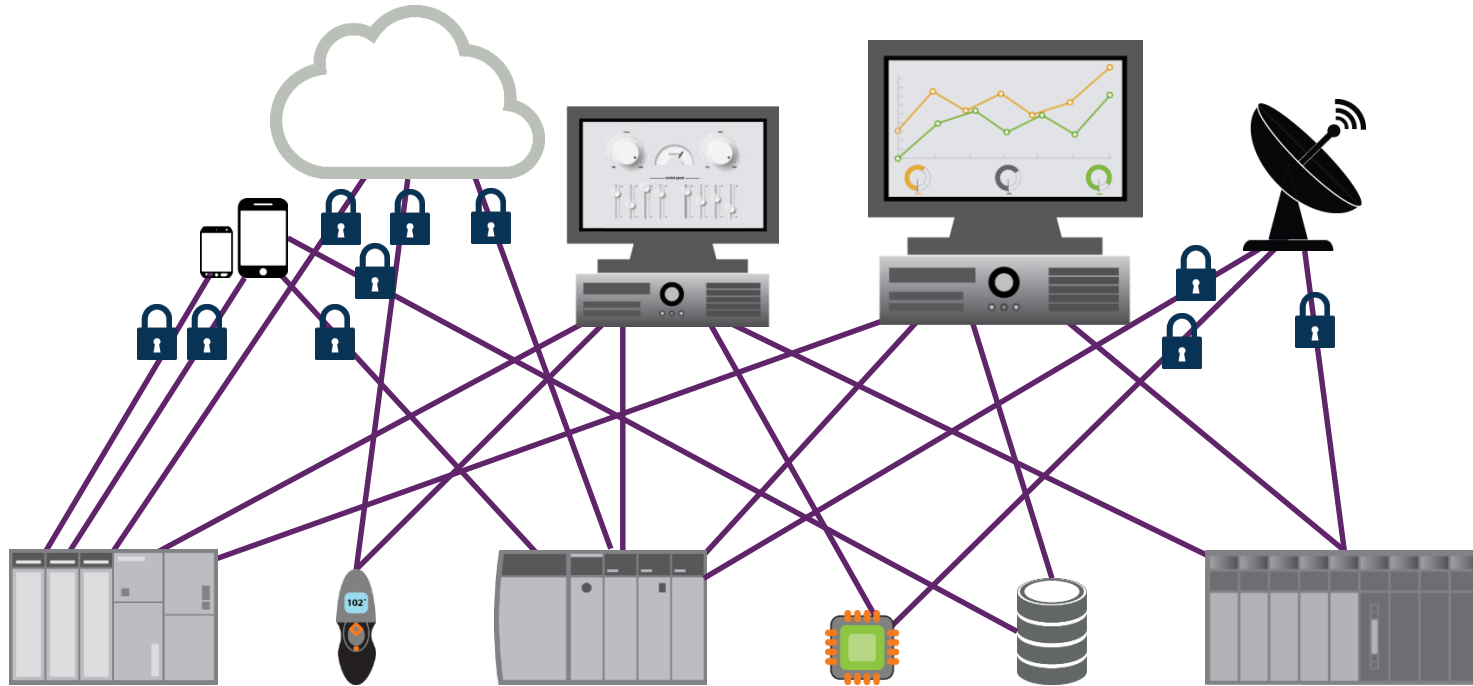

- **Global Connectivity** – across a shop-floor or across the world
- **Integration & interoperability** between production, non-production, business & IT systems
- **Data security** and integrity at every level
- **Real-time performance** & 24/7/365 **reliability**
- **Centralisation, simplification & standardisation** of industrial data solutions
- **Business continuity**, through Diagnostics, Redundancy & Recovery capabilities

## IS DESIGNED FOR THESE TYPES OF APPLICATIONS

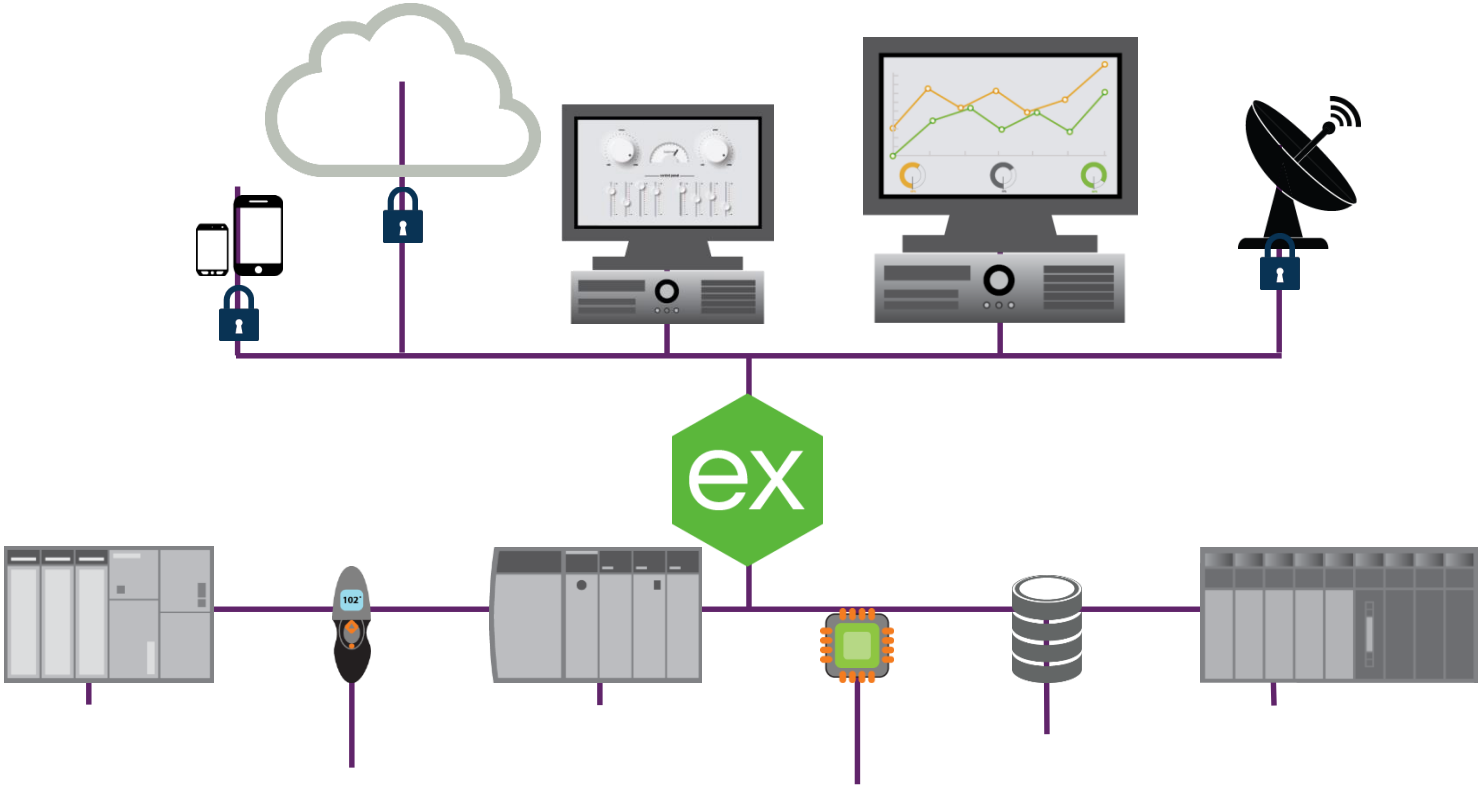

# A ENTERPRISE-WIDE CONNECTIVITY PLATFORM

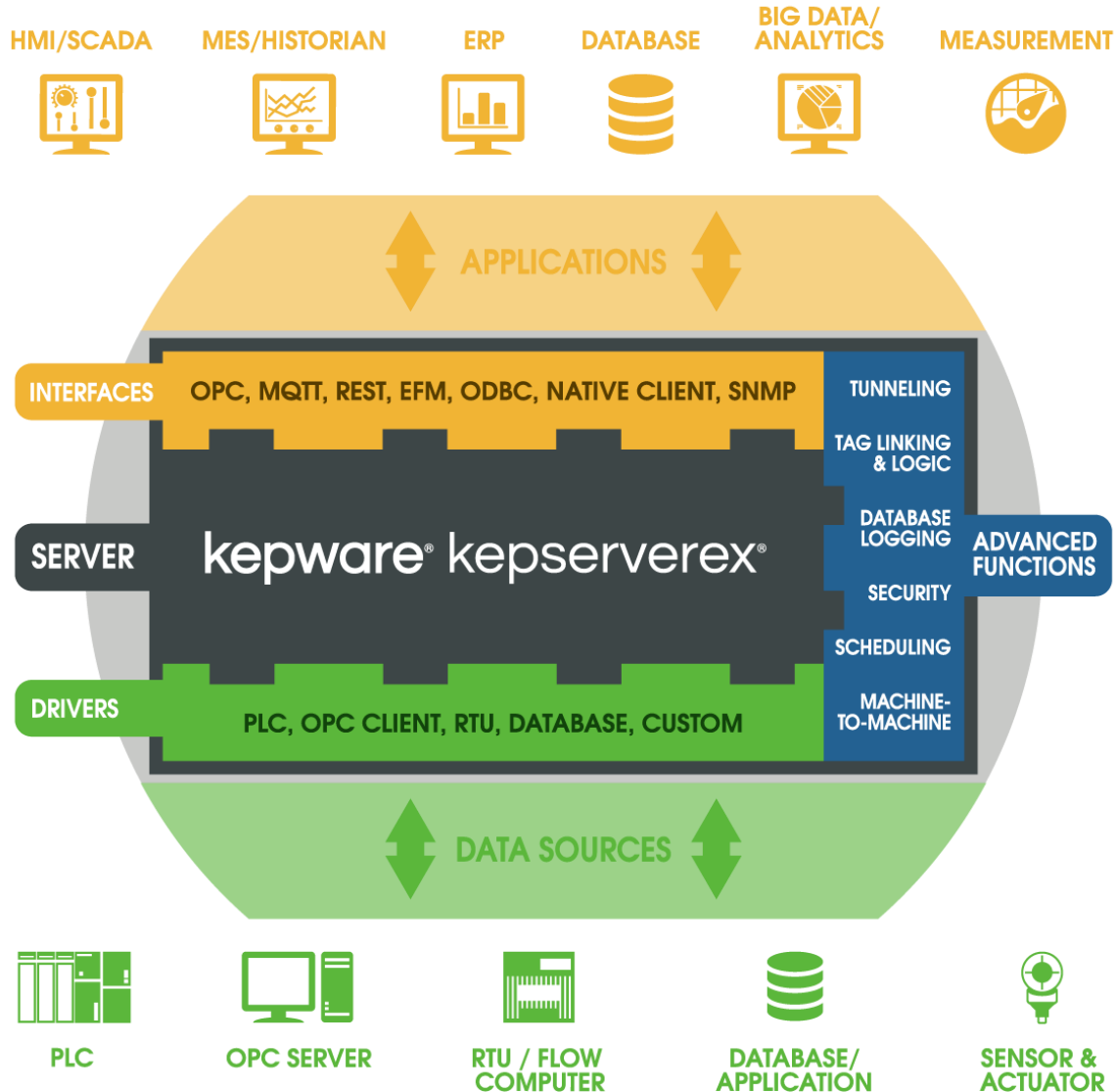

- **Multi-Language support**
  - English, German & Japanese
- **Multi-layer Interoperability**
  - Production layer connectivity
  - IT & business-system layer connectivity
  - IoT & Cloud connectivity
- **Deep diagnostics on all client-side interfaces**

- **Programmatic KEServerEX configuration from 3rd-party, custom applications**
- **Extended functionality through Plug-in options**

- **150+ Data Source Drivers**
- **High-performance server core**
- **Deep diagnostics on all source drivers**
- **Media level redundancy for critical data**



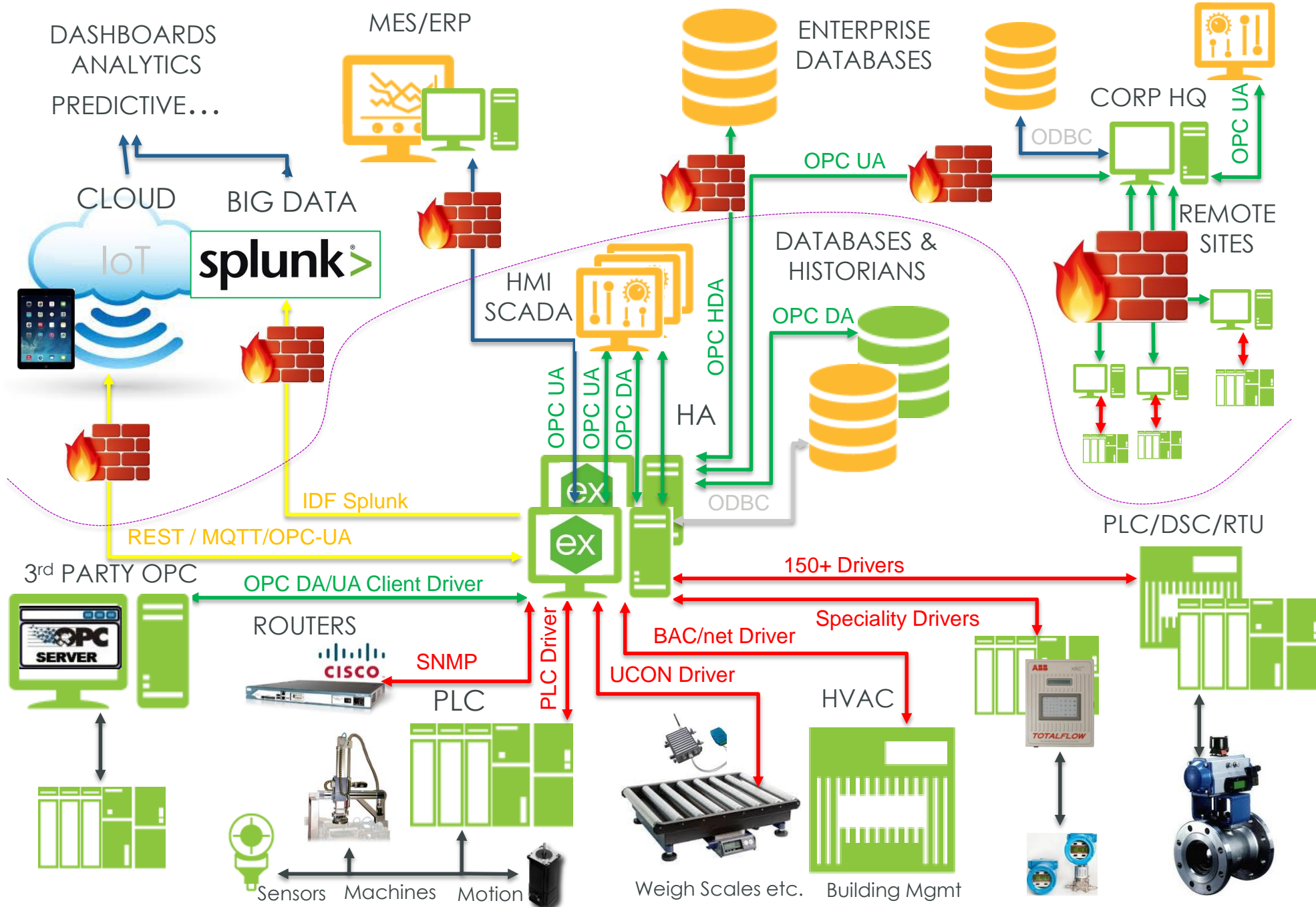

# SECURE DATA TUNNELING

## OPC UA Client Driver

- Utilises OPC UA, a non-proprietary, open-standard protocol
- Creates a secure, authenticated connection through firewalls and across networks, with any standard OPC-UA Server
- Can be added to legacy OPC-DA installations, to eliminate reliance on Microsoft COM and DCOM technology

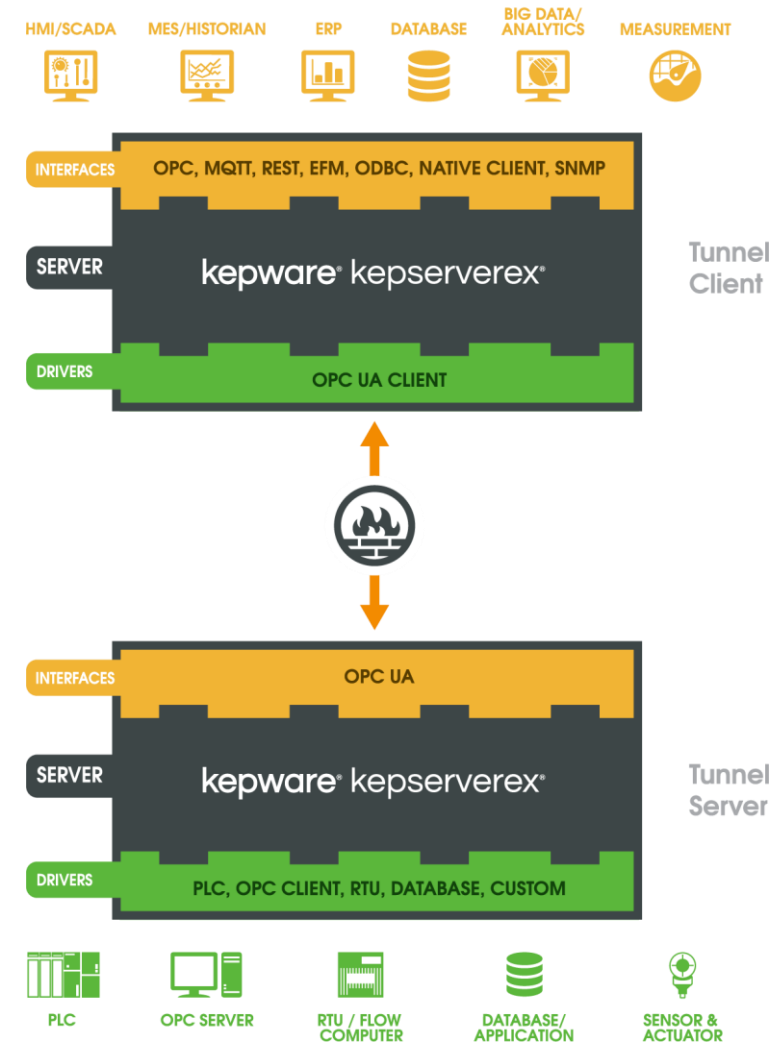
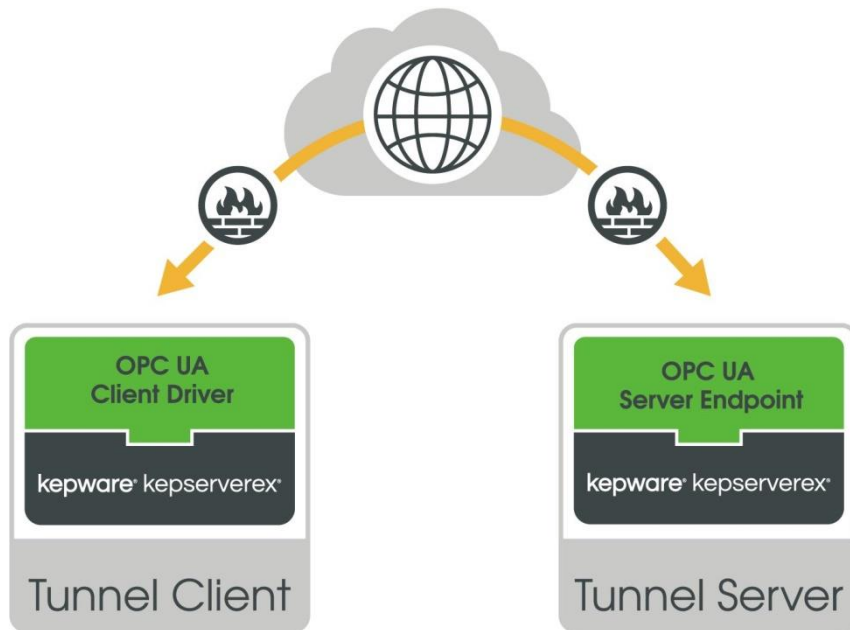

# Real world KEPServerEX® use cases

# REMOTE OPC-DA CONNECTION – OIL&GAS

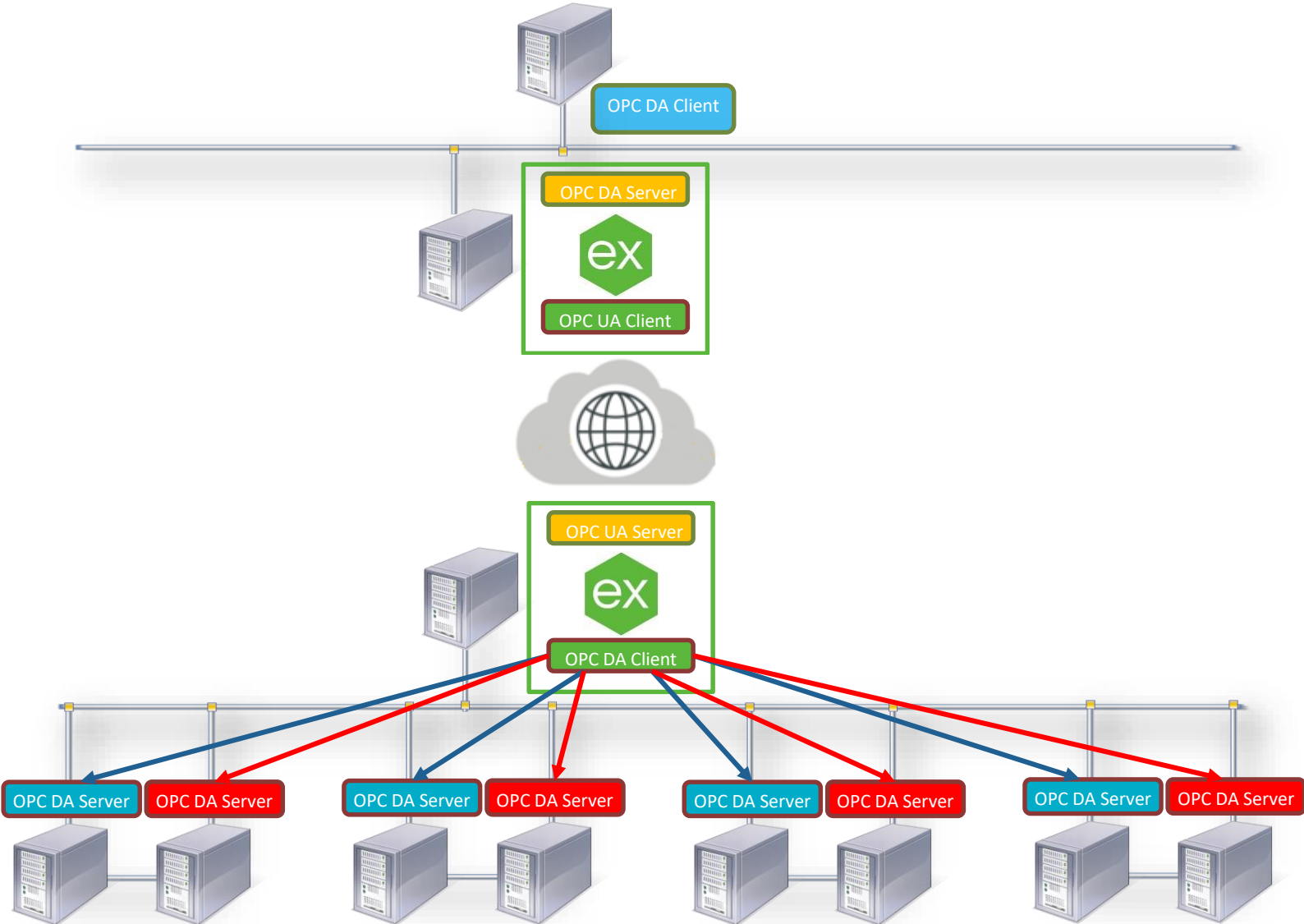

# REMOTE OPC-DA CONNECTION – OIL&GAS

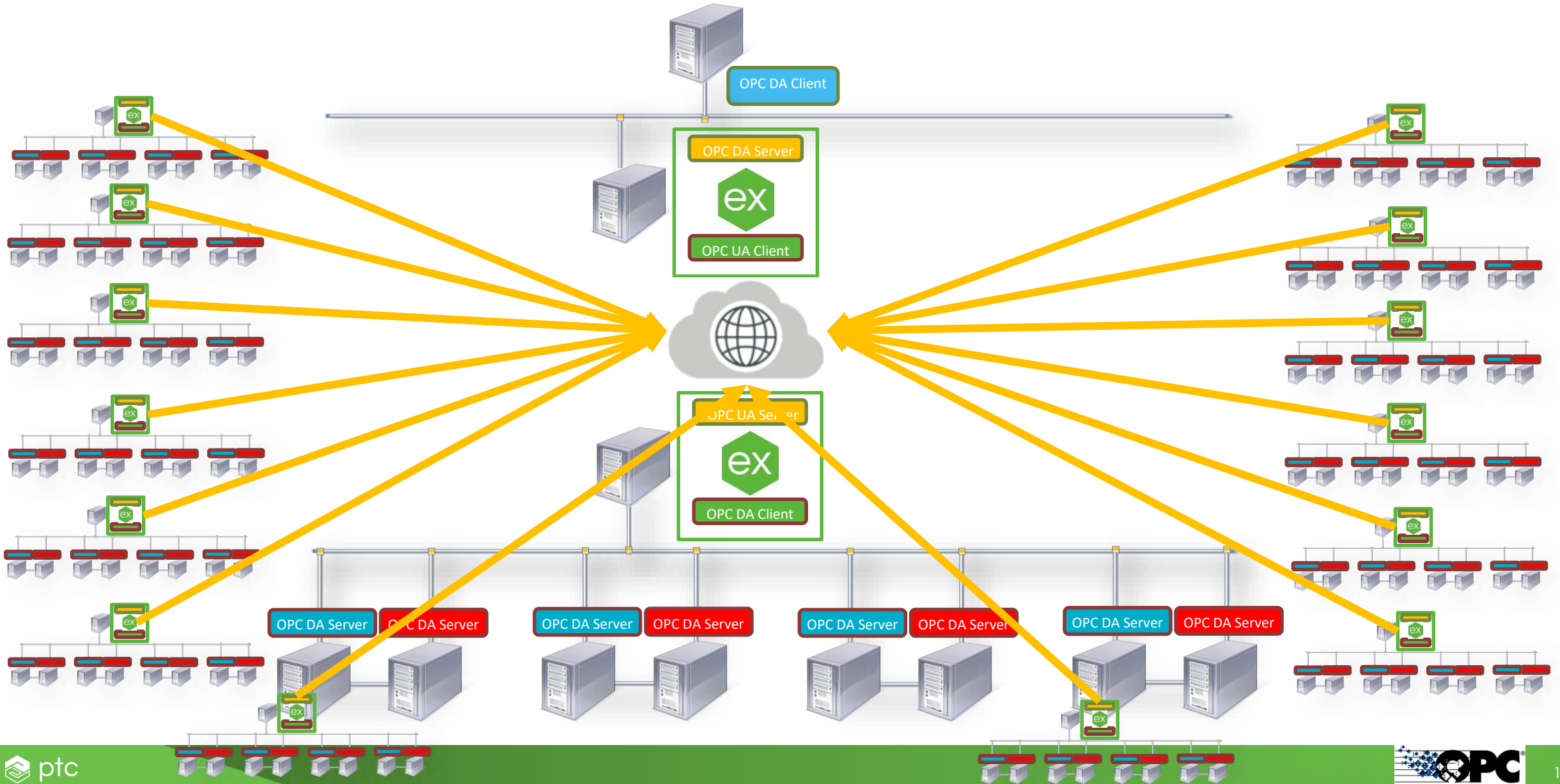

# CONNECT IT AND OT NETWORKS - PHARMA

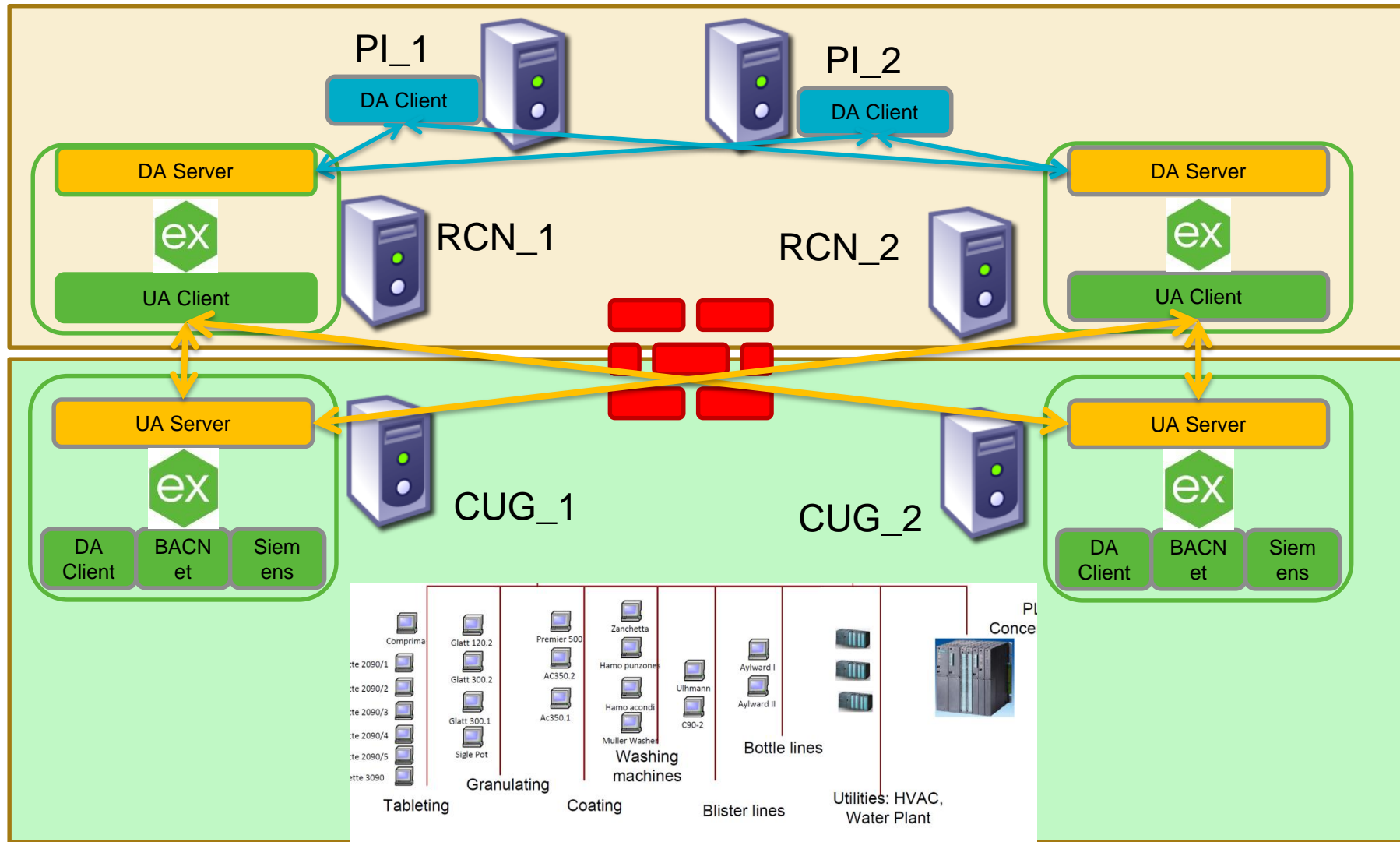

# INTERNET OF THINGS (THINGWORX PLATFORM)

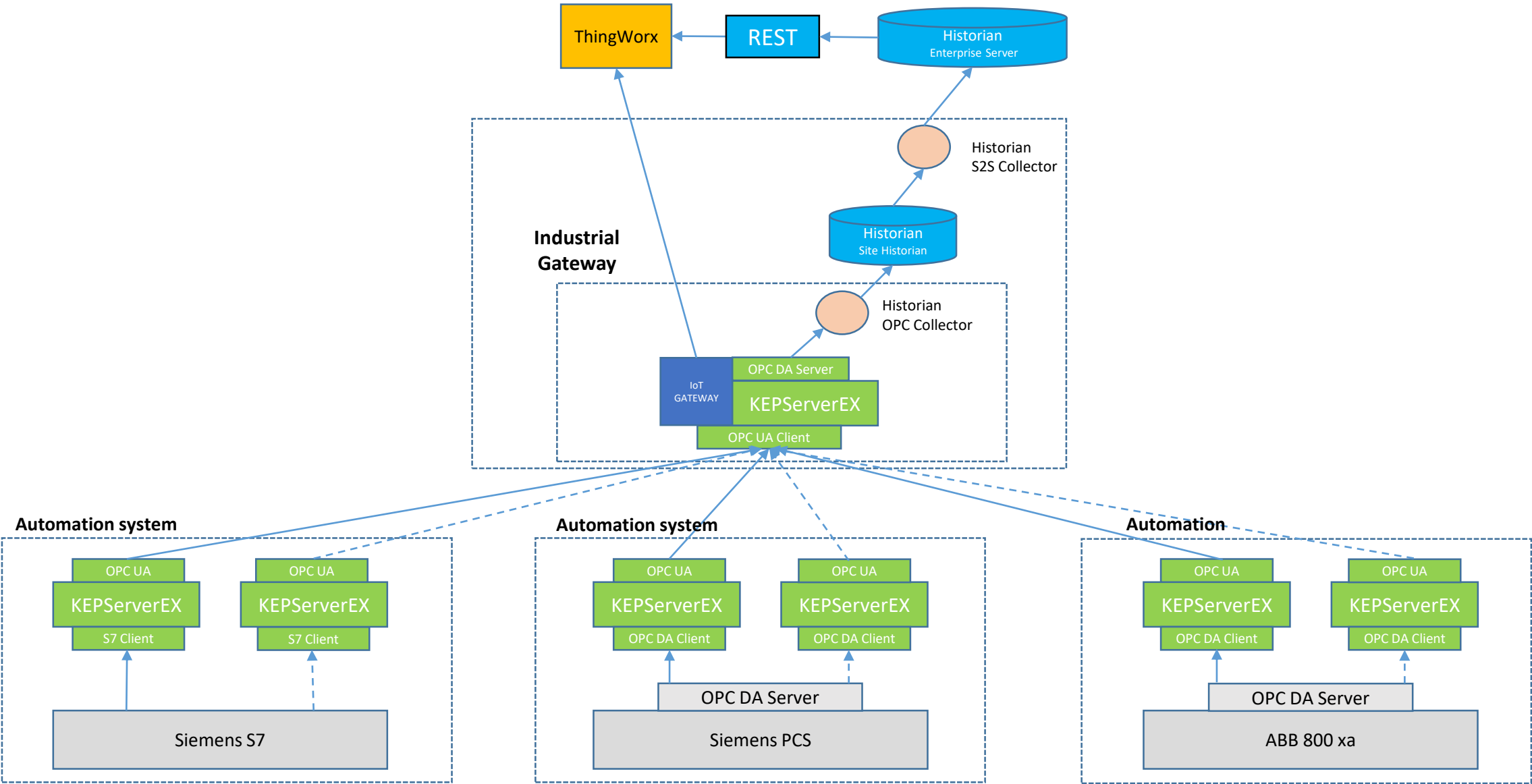

# Resources & Services



Product Training explores Kepware's solutions for Industrial Automation and the Internet of Things.

- Monthly training course in Portland, Maine
- On-site classes available upon request
- On-the-road training opportunities at special events

Topics include:

- Optimizing server communications
- Implementing diagnostic tools for troubleshooting and debugging
- Using leading technology like REST for web connectivity and OPC UA for tunneling secure data



# ONLINE RESOURCES

## Kepware.com

- Access fully-functioning demo downloads, in-depth product information, an extensive video collection, and case studies, whitepapers, and eBooks

## Social Media

- Stay up to date on product news, job opportunities, industry events, and photographs

## Blog

- Explore industry trends and technology, Kepware's culture and news, and tradeshow and event synopses

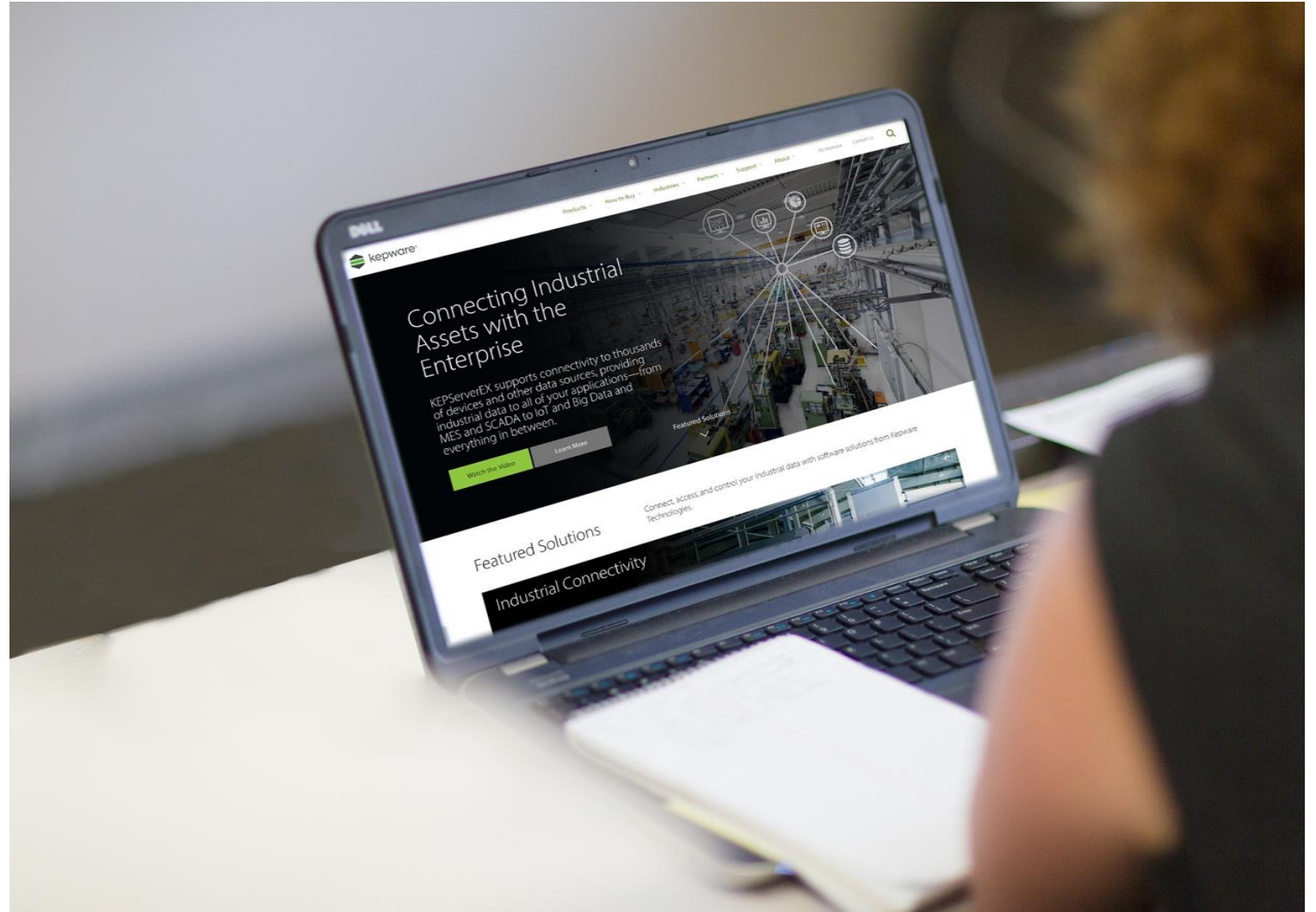

Kepware official Preferred Distributor  
in the Nordics and Benelux

# NOVOTEK

- [www.novotek.com](http://www.novotek.com)
- [info@novotek.fi](mailto:info@novotek.fi)

[www.kepware.com](http://www.kepware.com)



## Sales

Request a pre-sales consultation or pricing information

- x208
- [sales@kepware.com](mailto:sales@kepware.com)

## Training

Attend hands-on, customized training classes

- x155
- [training@kepware.com](mailto:training@kepware.com)

## Technical Support

Get assistance from experienced engineers

- x211
- [technical.support@kepware.com](mailto:technical.support@kepware.com)

## Blog

Stay up to date on the latest in automation and communications

- <https://info.kepware.com/blog/>

## Social Media

Find product news, industry updates, event coverage, and more

# OPC DAY FINLAND 2017

11.10.2017 #OPCUA #OPCDAYFINLAND #AUTOMATION #OPCDAY



## Thank you!

**BECKHOFF**

