

# REAR AXLE

## SECTION G

### CONTENTS

| Description ... ..                       | Page |
|--|------|
|  | 3    |
| <br><b>AXLE SHAFT</b>                    |      |
| —To remove ... ..                        | 4    |
| —To refit ... ..                         | 4    |
| —To remove and refit hub bearings ... .. | 5    |
| —Sludge guards (oil retainers) ... ..    | 3    |
| <br><b>BEVEL PINION</b>                  |      |
| —To dismantle ... ..                     | 6    |
| —To adjust ... ..                        | 7    |
| —Oil seal ... ..                         | 3    |
| <br><b>DIFFERENTIAL UNIT</b>             |      |
| —To remove and refit ... ..              | 6    |
| —To dismantle and reassemble ... ..      | 6    |
| —To adjust and refit ... ..              | 9    |
| —Measurements of bearings ... ..         | 12   |
| <br><b>REAR AXLE</b>                     |      |
| —To remove and refit ... ..              | 12   |
| —Breather ... ..                         | 12   |

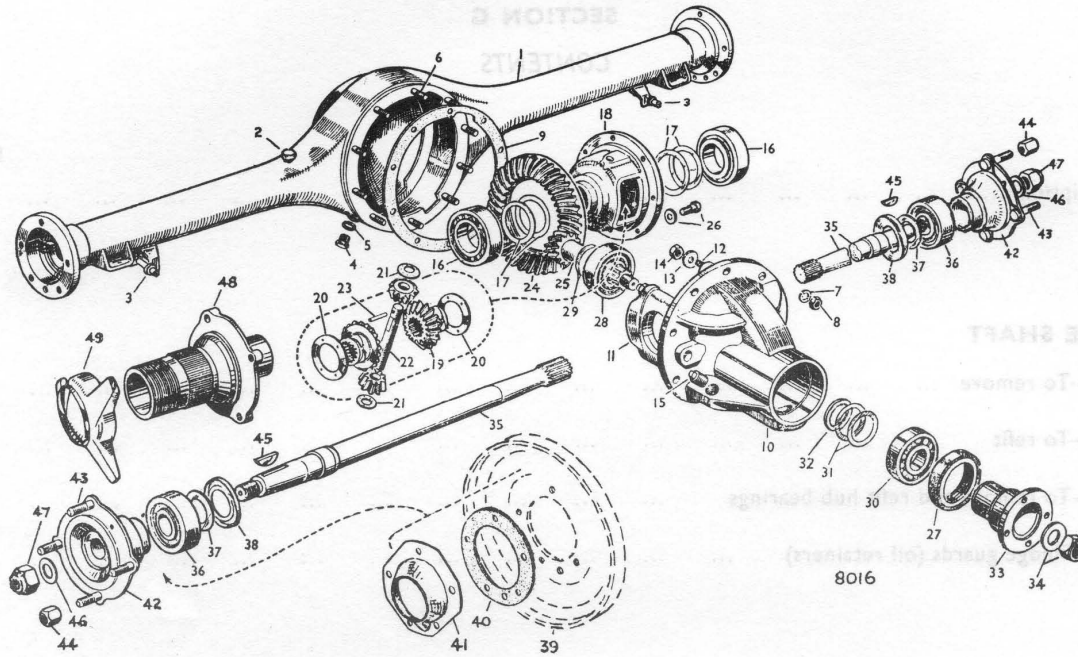

Fig. 1. Exploded view of rear axle

- |                            |                          |                           |
|----------------------------|--------------------------|---------------------------|
| 1. AXLE CASING             | 18. DIFFERENTIAL BOX     | 35. AXLE SHAFT            |
| 2. BREATHER                | 19. DIFFERENTIAL PINION  | 36. BEARING/OIL SEAL      |
| 3. SHOCK ABSORBER MOUNTING | 20. THRUST WASHER        | 37. SLUDGE GUARD INNER    |
| 4. DRAIN PLUG              | 21. THRUST WASHER        | 38. SLUDGE GUARD OUTER    |
| 5. WASHER                  | 22. CROSS PIN            | 39. BACKING PLATE         |
| 6. STUD                    | 23. LOCK PIN             | 40. GASKETS               |
| 7. SPRING WASHER           | 24. CROWN WHEEL          | 41. DUST COVER            |
| 8. NUT                     | 25. DRIVING PINION       | 42. HUB                   |
| 9. GASKET                  | 26. LOCK WASHER AND BOLT | 43. WHEEL STUD            |
| 10. DIFFERENTIAL HOUSING   | 27. OIL SEAL             | 44. WHEEL NUT             |
| 11. BEARING CAPS           | 28. INNER BEARING        | 45. KEY                   |
| 12. STUD                   | 29. SHIMS                | 46. WASHER                |
| 13. WASHER                 | 30. OUTER BEARING        | 47. HUB NUT               |
| 14. NUT                    | 31. SHIMS                | 48. HUB, WIRE WHEELS      |
| 15. LEVEL/FILLER PLUG      | 32. SHIM ABUTMENT WASHER | 49. QUICK RELEASE HUB NUT |
| 16. DIFFERENTIAL BEARING   | 33. DRIVER COUPLING      |                           |
| 17. SHIMS                  | 34. NUT AND WASHER       |                           |

## REAR AXLE

### DESCRIPTION

The rear axle is of the semi-floating type, with detachable taper and key fitting rear hubs, incorporating a hypoid bevel differential.

In design it is essentially straightforward, but as the position of the pinion relative to the crown wheel requires accurate adjustment, involving the use of special tools, it should remain undisturbed as far as possible.

Crown wheel and pinion adjustment is provided for by the positioning of shims adjacent to the bearings carrying the differential housing and the bevel pinion shaft, and described in detail in this Section. The complete differential assembly is detachable from the axle casing after removal of the axle shafts.

The axle shafts are fully machined and supported at the outer ends on sealed bearings, which also incorporate an oil seal.

### Bevel pinion oil seal

In the bevel pinion housing, an oil seal is provided just to the rear of the propeller shaft coupling.

When a replacement oil seal is fitted, the outside of the cage should be coated with jointing compound and the inner sealing face smeared with oil or grease.

These seals operate in one direction and must be fitted with the lip facing the differential assembly.

### Sludge guards (oil retainers)

A sludge guard, consisting of an outer ring fitted into a recess in the axle casing, is overlapped by an inner ring sandwiched between the bearing inner track and the abutment ring on the axle shaft.

The oil seal is an integral part of the sealed hub bearing and operates between the inner and outer tracks of the bearing.

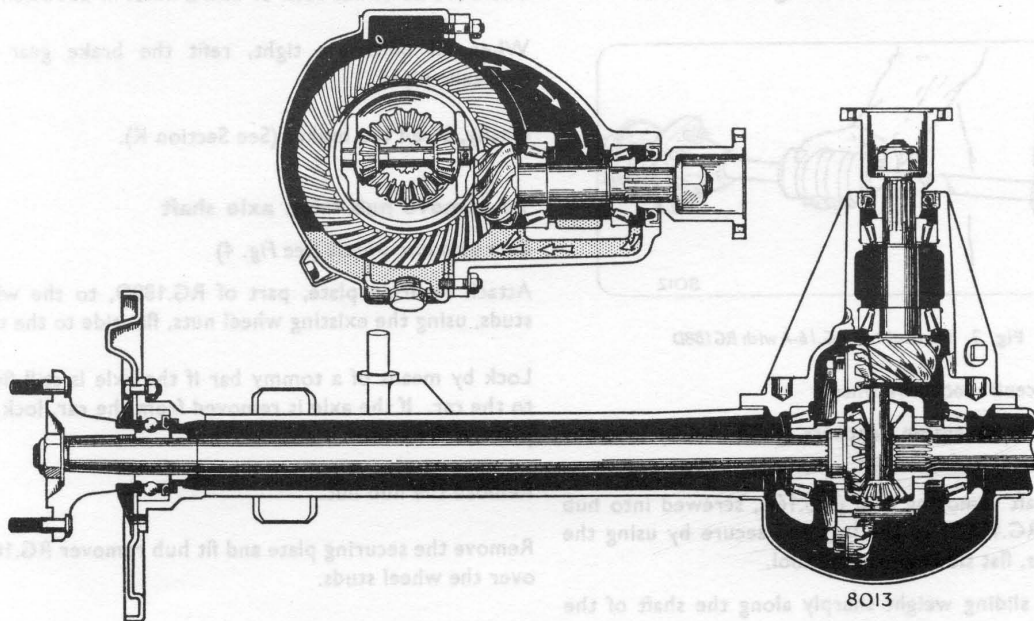

Fig. 2. Sectional view of rear axle

Two types of hub bearing may be fitted in production, one of which has an "O" ring in a groove round the outer periphery of the outer track. The two types of bearing with integral oil seal are interchangeable. *It must be noted that the axle shafts, hub assemblies and bearings for this axle are not interchangeable with the axles fitted to earlier models.*

**AXLE SHAFT**

**To remove**

Serious damage will result from any attempt to remove an axle shaft by any method other than the following:—

Remove road wheel.

Clean off all road dirt from the brake backing plate and axle flange.

Remove setscrew securing brake drum and remove drum.

Remove clevis pin from handbrake linkage and disconnect hydraulic line.

Protect the hydraulic connections from the ingress of foreign matter.

Remove nuts and bolts securing back plate to axle flange.

*Cars with disc wheels*

Fit the shaft removing tool (RG.16A screwed into hub remover RG.188D) over the four wheel studs and secure by using the wheel nuts, flat side against the tool.

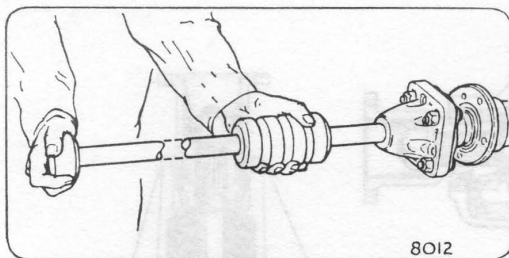

Fig. 3. Removal tool RG.16-A with RG188D

*Cars with centre-lock wire wheels*

Fit the four extension adaptors (RG.16A-5A) into the brake drum securing holes.

Fit the shaft removing tool (RG.16A, screwed into hub remover RG.188D) to the legs and secure by using the wheel nuts, flat side against the tool.

Move the sliding weight sharply along the shaft of the tool, against the outer abutment, to draw the shaft out of the casing.

Remove the shaft complete with the back plate, integral bearing/oil seal, inner sludge guard and hub.

Remove outer sludge guard from the recess in the axle casing.

**To refit**

Renew all joint washers. It is essential that the bearing, axle casing and brake back plate are clean during assembly.

Fit the outer member of the sludge guard into the bearing recess in the axle casing, open side outwards.

Pass the shaft into the casing and ease the splines into mesh with those in the differential side gears.

Pushing the shaft inwards, enter the bearing into the recess in the axle casing and carefully drive the assembly inwards until the bearing outer face is flush with the end of the casing.

Ensuring that all remaining parts are clean, fit the back plate and dust shield.

Fit the back plate bolts and nuts, tighten fully, but evenly and diagonally.

There are no dowel bolts or dowel holes in this assembly.

When all bolts are tight, refit the brake gear and hydraulic pipes.

Finally, bleed the brakes (See Section K).

**To remove hub from axle shaft**

*Cars with disc wheels (see Fig. 4)*

Attach securing plate, part of RG.188D, to the wheel studs, using the existing wheel nuts, flat side to the tool.

Lock by means of a tommy bar if the axle is still fitted to the car. If the axle is removed from the car, lock the plate in the vice.

Remove the hub nut.

Remove the securing plate and fit hub remover RG.188D over the wheel studs.

Fit the protector sleeve over the shaft thread and secure the tool with the wheel nuts.



*Cars with centre-lock wire wheels*

Attach the securing plate to the hub with the setscrews supplied.

Lock the plate with a tommy bar, if the axle is still fitted to the car.

If the axle is removed from the car, lock the plate in a vice.

Remove the hub nut.

Remove the securing plate and fit the four extension adaptors, RG.16A-5A, to the hub by screwing into the brake drum securing holes.

Place the long protector sleeve over shaft thread, fit the hub remover, RG.188D, to extension adaptors and secure with the wheel nuts.

Screw in the centre bolt of the tool until tight, then smartly tap the end of the hub remover bolt.

Remove hub and hub remover.

Remove dust shield and back plate, remove key from axle shaft.

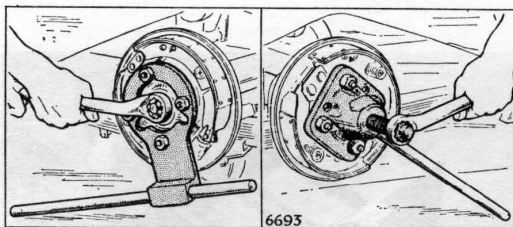

Fig. 4. Removing rear hub

**To remove rear hub bearings** (See Fig. 5)

Withdraw axle shaft and dismantle. (See "Axle shaft—To remove").

Slide the remover plate (Part of tool RG.188D-1A) over the splined end of the axle shaft, until the plate locates on the hub bearing inner race.

Screw in the four extension adaptors (RG.16A-5A) and fit the hub remover and short protector.

Rotate the centre bolt of the hub remover and draw the bearing off the axle shaft.

As the oil seal is integral with the bearing, the complete bearing must be changed should it become necessary to change the oil seal.

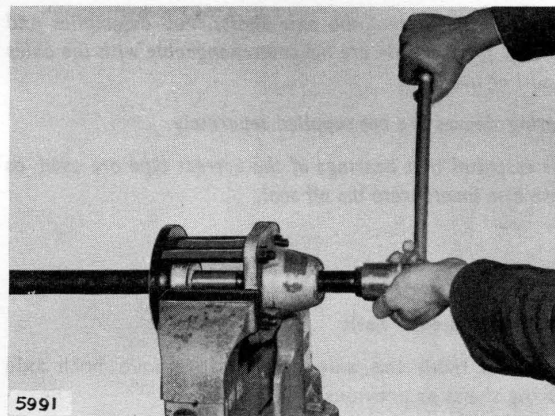

Fig. 5. Removing hub bearing

**To refit**

The lateral location of the hub bearing is controlled by a sleeve on the inner side of the bearing, against which the latter is located by the hub when fully positioned on the taper of the shaft.

It is essential that when new bearings are fitted, or old ones replaced, that the inner race should be compressed between the sleeve and the hub.

When fitting a bearing, therefore, the following procedure must be adopted:—

Slide the remover plate and hub remover assembly over the axle shaft from the tapered end.

Fit the split bush (Part of RG.188D-1A) to the remover plate, with the flanged side of the bush butting behind the sleeve.

Fit the short protector over the axle shaft threads.

Rotate the centre bolt of the hub remover until the sleeve has been pulled  $\frac{1}{8}$  in. (.8 mm.) towards the outer end of the axle shaft.

Remove the tool, fit the inner sludge guard and bearing/oil seal to the axle shaft.

Be sure to fit the bearing with the oil seal inwards.

Press the bearing on the shaft until the inner sludge guard is just nipped.

Fit the back plate and dust cover, fit the key and hub, then fit the securing plate over the wheel studs using the wheel nuts to secure the tool. Use the setscrews provided for wire wheel hubs.

Place the whole assembly in a vice, fit the nut and washer and torque to the figure given in General Data.

Check that compression of the bearing is obtained by attempting to rotate the inner sludge guard.

The assembly can now be fitted to the axle casing. (See "Axle shaft—To refit").

*It must be noted that the axle shafts, hub assemblies and bearings for this axle are not interchangeable with the axles on earlier models.*

*Bearing sleeves are not supplied separately.*

*It is essential that bearings of the correct type are used, as these also incorporate the oil seal.*

## DIFFERENTIAL UNIT

### To remove and refit

Drain oil from the axle case and remove both axle driving shafts as previously described.

Disconnect propeller shaft from rear axle coupling.

Remove the nuts and washers securing the differential housing to axle casing and lift out assembly.

When replacing the assembly, the operations are a reversal of the above.

All joint faces must be clean and free of burrs.

Use new joints and coat the mating faces with Hylomar jointing compound.

Bleed the brakes on completion of the axle assembly. (See Section K).

### To dismantle and reassemble

Remove assembly from axle casing as previously described.

Remove caps (11, Fig. 1) over differential bearings and ensure that they are not interchanged.

Lift off the differential assembly complete with crown wheel and bearings, taking care that the outer races of the bearings are not interchanged.

Remove the crown wheel by releasing the lockwashers and withdrawing the eight setscrews (26).

Knock out taper pin (23) securing cross-pin (22) in differential box.

Push out cross-pin, then the differential pinions complete with thrust washers (21) can be carried round and brought out through the opening in the differential box.

On no account should any attempt be made to remove the cross-pin (22) without first removing the crown wheel, as removal of the cross-pin is obstructed by the teeth of the crown wheel.

The differential wheels and thrust washers can now be taken out through the same openings.

Reverse the foregoing procedure for reassembly, with careful attention to the following points:—

1. The faces of both crown wheel and differential box should be thoroughly clean and free from burrs or bruises, otherwise there is every possibility of misalignment after assembly.
2. The lockwashers for the eight setscrews must be renewed and the setscrews tightened to the torque figure given in General Data.
3. The bearing cap nuts must be tightened to the torque figure given in General Data.
4. Mount a dial indicator on the casing with the stylus against the back face of the crown wheel. Check for run-out by rotating the crown wheel. This must not exceed .003 in. (.8 mm.).

If bearings on crown wheel and pinion are renewed, refer to the following paragraphs:—

If it is necessary to renew the differential bearings, the old inner races may be removed by using V.L.C. tool RG.4221B and adaptor RG.4221B-20. (See Fig. 6).

The inner and outer sections of these bearings must be renewed as a pair.

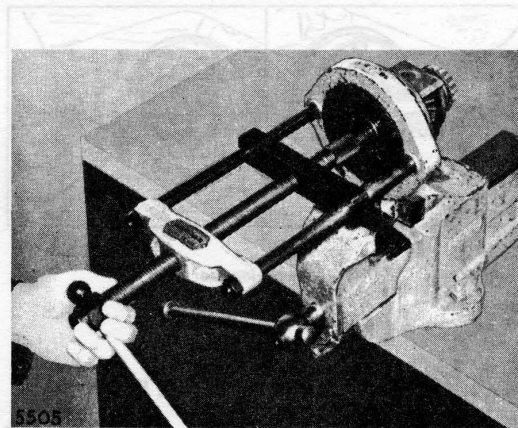

Fig. 6. Removing differential bearing

## BEVEL PINION

### To dismantle

Remove the differential unit from the axle complete with crown wheel and bearings as previously described.

Lock the propeller shaft coupling with V.L.C. tool RG.421. Remove the nut and washer and draw the coupling off the pinion shaft.

Tap the bevel pinion rearwards out of the housing, using a soft metal drift.

The inner bearing race and shims will be detached with the pinion.

To remove the inner bearing race from the pinion shaft, a hand press, RG.4221B, or a press and V.L.C. taper base 370, will be required. (See Fig. 7).

Support the inner race by means of the adaptor RG.4221B-21 and apply pressure to the threaded end of the shaft. Remove the shims but do not discard them.

Remove the oil seal and outer bearing race from the front of the housing.

If new bearings are required, the old bearing outer tracks may be removed and new tracks fitted, using V.L.C. tools RG.447 and RG.448.

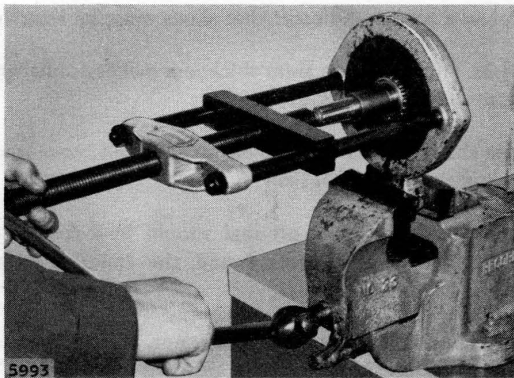

Fig. 7. Removing pinion inner bearing

**To adjust**

The bevel pinion must be correctly adjusted in two respects:—

1. Position of the pinion relative to the axis of the crown wheel.
2. Pre-load of the bearings.

To obtain the degree of accuracy necessary, V.L.C. kit RG.295B will be required.

To adjust position of pinion relative to the crown wheel axis (Figs. 10 and 12). Note in Fig. 8 the shim positions denoted A and B.

During assembly, a small number of each of the following shims will be required:—

|         |                    |              |
|---------|--------------------|--------------|
| 9071049 | .003 in. (.08 mm.) | } Shims<br>A |
| 9071050 | .005 in. (.13 mm.) |              |
| 9071051 | .010 in. (.25 mm.) |              |
| 9071132 | .020 in. (.50 mm.) |              |
| 9071147 | .003 in. (.08 mm.) | } Shims<br>B |
| 9071148 | .005 in. (.13 mm.) |              |
| 9071149 | .010 in. (.25 mm.) |              |
| 9071133 | .020 in. (.50 mm.) |              |

Take the dummy pinion shaft and place on it the inner pinion bearing.

**DO NOT FIT ANY SHIMS BETWEEN THE BEARING AND THE PINION HEAD.**

Insert the assembly into the casing and fit the outer bearing, coupling, washer and dummy nut.

Progressively tighten the dummy nut to absorb all end float, until a slight resistance to turning is felt.

Fit the dummy bearings into the differential housing and fit the mandrel through them.

Replace the two bearing caps and tighten the four securing nuts.

Using feeler gauges, measure the gap between the end of the dummy pinion shaft and the mandrel. (See Fig. 10).

Note any measurement engraved on the head of the actual pinion.

This figure shows, in thousandths of an inch, any variation in the position of the tooth form relative to the rear bearing shoulder, which has occurred during manufacture.

If no figure is marked, this indicates a zero reading requiring no correction to the calculation.

Any letters engraved on the head are for production purposes only and may be ignored.

If this figure is preceded by a negative sign —, ADD this amount to the gap measurement taken. If the figure has a positive sign +, SUBTRACT the amount from the gap measurement.

The resulting dimension would be the thickness of shims to be added to the actual pinion at point B (Fig. 12) to position the pinion relative to the crown wheel axis.

In practice, however, it is found that as the bearing is pressed on to the actual pinion, the bearing alters in length approximately .002 in. (.05 mm.). Therefore, .002 in. (.05 mm.) must be subtracted from the shim thickness required at point B.

Remove the dummy pinion from the casing.



Place the shims B on the actual pinion and press the inner bearing, lightly oiled, into place, using the hand press RG.4221B and adaptor RG.4221B-21, or a press and V.L.C. taper base 370.

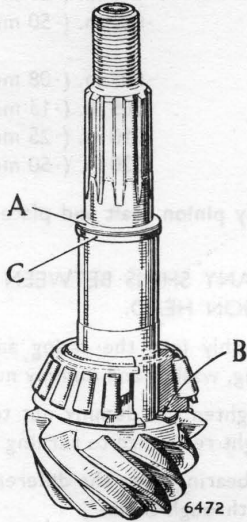

Fig. 8. Pinion shims and abutment washer

Fit the shim abutment washer, bevelled edge towards the shoulder (C, Fig. 8).

Place onto point A on the actual pinion, the same thickness of shims as at point B and ADD .018 in. (.46 mm.).

Insert the pinion into the casing and fit the outer bearing, lightly oiled.

DO NOT fit the oil seal at this stage.

Replace the coupling, nut and washer.

#### To obtain pre-load

Pre-load is obtained when a resistance is felt to turning, while rotating the coupling by hand with the nut tightened to the torque given in General Data.

Rotate the pinion and tighten the nut progressively.

**FAILURE TO ROTATE THE PINION MAY LEAD TO FALSE PRE-LOAD OR BEARING DAMAGE.**

If the pinion becomes excessively tight before the nut is tightened to the correct torque, additional shims are required at point A.

If the correct torque is reached and no resistance is felt on the coupling, shims must be removed from point A.

#### To test for correct pre-load

The pre-load is assessed by measuring the torque required to rotate the shaft.

The torque should be 6—12 lbs/in. (.07—0.14 kg/m.) for new bearings, or 4—8 lbs/in. (.05—0.09 kg/m.) for the original bearings.

The torque can be checked using a 3 ft. (1 metre) length of cord attached to a spring balance.

Take four or five turns of the cord round the coupling as shown in Fig. 9. Rotate the coupling by pulling on the spring balance.

Note the reading when the coupling is rotating, NOT as the coupling starts to rotate.

The reading on the scale should be 6—12 lbs. (2.7—5.4 kgs.) for new bearings, or 4—8 lbs. (1.8—3.6 kgs.) for the original bearings.

Too high a torque indicates that more shims must be added to point A.

Too low a torque indicates that shims must be removed.

.001 in. (.025 mm.) in shim thickness makes a difference of approximately 4 lbs. (1.8 kgs.).

When the torque is correct, remove the nut, washer and coupling and fit the oil seal.

The outer case of the oil seal should be coated with Hylomar jointing compound and the inner seal face smeared with oil or grease.

Fit the coupling, washer and a new nut.

Tighten the nut to the torque figure given in General Data.

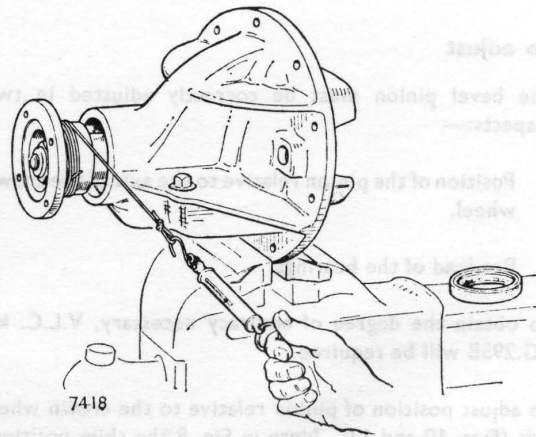

Fig. 9. Checking torque loading (pre-load) for pinion bearings



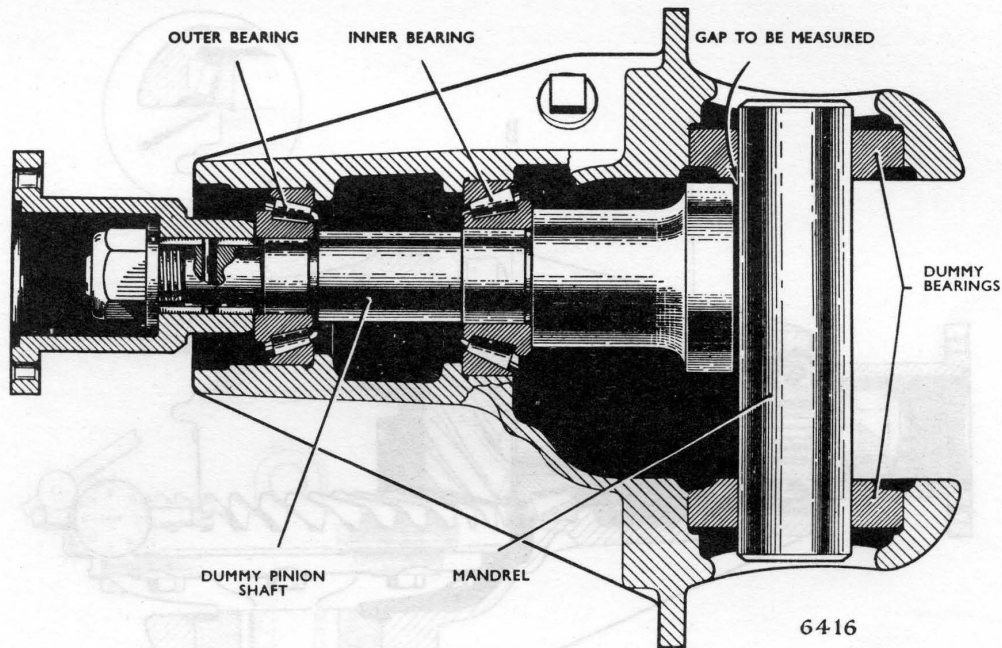

Fig. 10. Jigs used for adjusting bevel pinion pre-load, and pinion position relative to crown wheel axis. Note also shimming positions for pinion adjustment

## DIFFERENTIAL UNIT

### To adjust and refit

Having carried out the preceding operations, remove the differential box, bearings and shims as previously described.

In their place fit the dummy bearings, without any shims, their inner faces abutting the differential box.

The dummy bearings MUST be maintained in this position during subsequent operations.

Place the differential box assembly complete with dummy bearings into position in the housing. (See Fig. 12).

Replace the bearing caps and tighten the securing nuts until the dummy bearings are just gripped.

Mount a dial indicator on the differential housing, with the stylus against the heel of one of the crown wheel teeth, as nearly in line with the direction of tooth travel as possible.

Check the back-lash by moving the crown wheel but preventing the pinion from rotating, as shown in Fig. 11.

Adjust back-lash to between .005—.009 in. (.13—.23

mm.) by tapping the appropriate dummy bearing inwards, using V.L.C. tool RG.292, and main tool 550.

Check for back-lash in at least three positions on the crown wheel.

Paint the teeth of the crown wheel with a suitable marking and rotate to obtain an impression of the pinion tooth bearing.

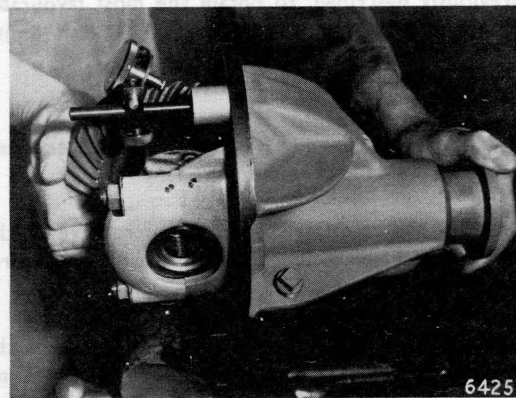

Fig. 11. Checking backlash

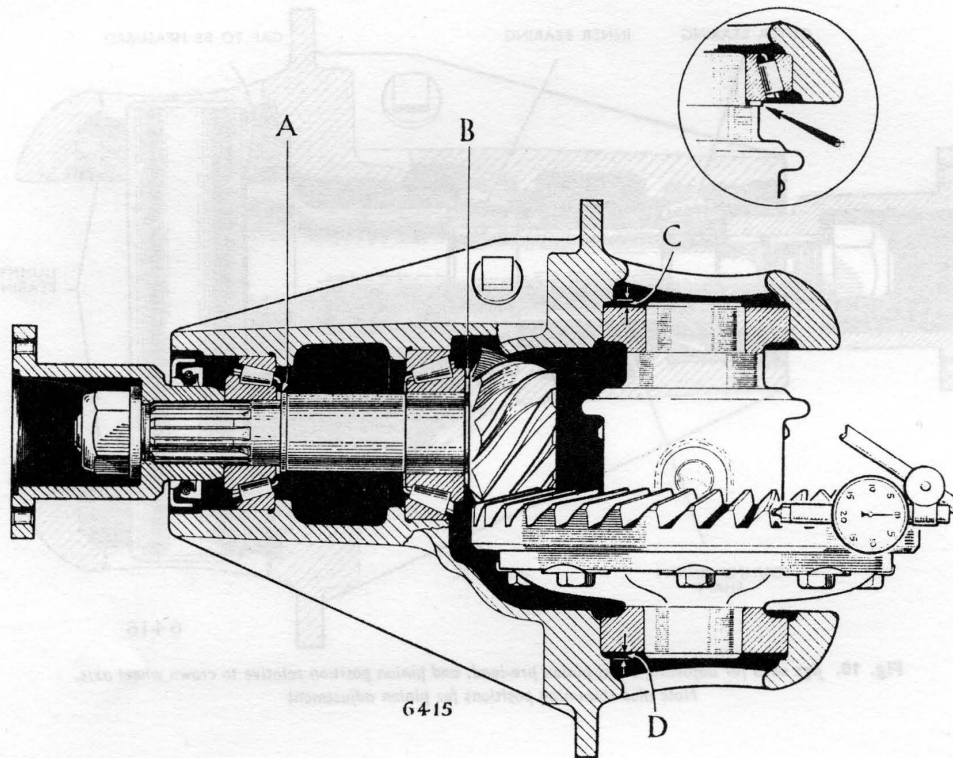

Fig. 12. Adjustment of crown wheel bearings

When correctly meshed, the marking so obtained should be as example A, Fig. 14, i.e. the area of contact is between the crown and base of the tooth and slightly nearer the toe (inner end) than the heel (outer end).

If necessary, adjust the crown wheel into or out of mesh, as previously described, to obtain the most favourable tooth marking, within the specified back-lash limits.

See D and E, Fig. 14.

If markings are as shown in B and C, Fig. 14, a re-adjustment of the pinion is necessary.

This entails the resetting of the pinion relative to the crown wheel, which includes the adjustment of the pre-load.

Having obtained the correct adjustment, measure the gaps between the outer faces of the dummy bearings and the casing (points C and D, Fig. 12), using feeler gauges as shown in Fig. 13.

Now measure the difference in thickness between the dummy bearing and the actual bearing for each side.

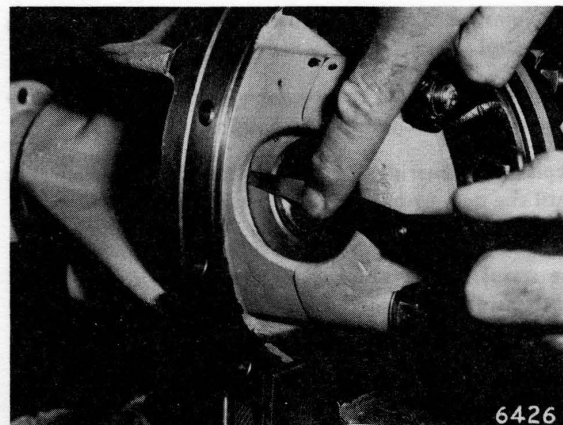
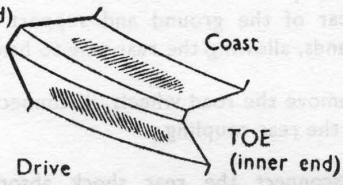
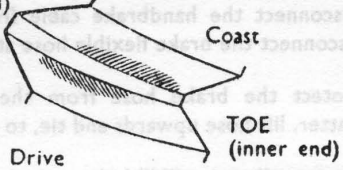
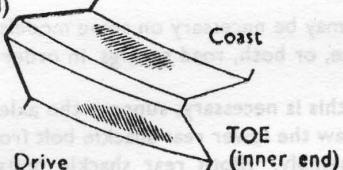
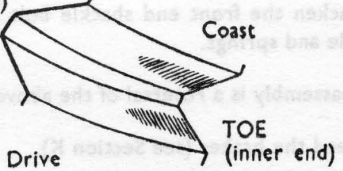
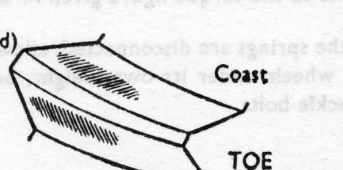

Fig. 13. Measuring gap between dummy bearing and casing

**TOOTH CONTACT CHART**

|          | Tooth Contact  | Condition   | Remedy  |
|----------|--|---|---|
| <b>A</b> | <p>HEEL (outer end)</p>  <p>Coast</p> <p>Drive</p> <p>TOE (inner end)</p>   | <p><b>IDEAL TOOTH CONTACT</b> evenly spread over profile, nearer toe than heel.</p> |   |
| <b>B</b> | <p>HEEL (outer end)</p>  <p>Coast</p> <p>Drive</p> <p>TOE (inner end)</p>   | <p><b>HIGH TOOTH CONTACT</b> heavy on the top of the drive gear tooth profile.</p>  | <p>Move the Drive PINION <b>DEEPER</b> into MESH, i.e. Reduce the pinion cone setting.</p>                |
| <b>C</b> | <p>HEEL (outer end)</p>  <p>Coast</p> <p>Drive</p> <p>TOE (inner end)</p> | <p><b>LOW TOOTH CONTACT</b> heavy in the root of the drive gear tooth profile.</p>  | <p>Move the Drive PINION <b>OUT</b> of MESH, i.e. Increase the pinion cone setting.</p>                   |
| <b>D</b> | <p>HEEL (outer end)</p>  <p>Coast</p> <p>Drive</p> <p>TOE (inner end)</p> | <p><b>TOE CONTACT</b> hard on the small end of the drive gear tooth.</p>            | <p>Move the Drive GEAR <b>OUT</b> of MESH, i.e. <b>INCREASE BACKLASH.</b></p>                             |
| <b>E</b> | <p>HEEL (outer end)</p>  <p>Coast</p> <p>Drive</p> <p>TOE (inner end)</p> | <p><b>HEEL CONTACT</b> hard on the large end of the drive gear tooth.</p>           | <p>Move the Drive GEAR <b>INTO</b> MESH, i.e. <b>DECREASE BACKLASH BUT MAINTAIN MINIMUM BACKLASH.</b></p> |

6102

Fig. 14. Specimen tooth markings on crown wheel



**Measurement of bearings**

This requires great accuracy and may present a little difficulty. Two methods may be used.

1. Mount a clock gauge on a surface plate and set to zero on the dummy bearing. A reading taken on the actual bearing gives the difference.
2. Alternatively, the difference may be found by the use of feeler gauges and a straight edge, if both are placed on a surface plate.

If the actual bearing is thicker than the dummy bearing, the amount must be *subtracted* from the measurement of the gap, but if the actual bearing is thinner, then the difference must be *added*.

The result gives the thickness of the shims required for each side, but .002 in. (.050 mm.) must be added to each side to provide the necessary pre-load for the bearings.

For example, side C, Fig. 12:—

|  |        |   |                    |
|--|--------|---|--------------------|
| Measurement of gap C   | ...    | + | .033 in. (.84 mm.) |
| Actual bearing .003 in. (.07 mm.) thicker than dummy bearing | ... .. | - | .003 in. (.07 mm.) |
| Pre-load   | ... .. | + | .002 in. (.05 mm.) |
| Shims required (side C)                                      | ...    | + | .032 in. (.82 mm.) |

Use the same method to find the shims for the other side (side D).

Remove differential box from casing and dismantle the dummy bearings.

Place the shims in position and fit the actual bearings, with the aid of tool RG.292 and main tool 550.

Replace the differential box in the housing and refit the caps.

Tighten the bearing cap nuts to the torque figure given in General Data.

**REAR AXLE**

**To remove and refit**

In the majority of cases, it will be quite unnecessary to remove the rear axle from the car, but should it become necessary to do so, the following procedure should be adopted:—

Jack up the rear of the car until the road wheels are clear of the ground and support the underframe on stands, allowing the rear axle to hang on the springs.

Remove the road wheels, disconnect the propeller shaft at the rear coupling.

Disconnect the rear shock absorbers at the lower mounting.

Disconnect the handbrake cable from the linkage and disconnect the brake flexible hose at the union coupling.

Protect the brake hose from the ingress of foreign matter, lift hose upwards and tie, to prevent loss of fluid.

Remove all spring "U" bolts and withdraw the axle from between the springs.

It may be necessary on some models to lower the end of one, or both, road springs, in order to remove the axle.

If this is necessary, support the axle on a jack and withdraw the lower rear shackle bolt from the spring hanger assembly. (Both rear shackle bolts where the hanger assembly has integral plates and pins).

Slacken the front end shackle bolt before lowering the axle and springs.

Reassembly is a reversal of the above operations.

Bleed the brakes (see Section K).

When refitting the axle to the springs, tighten the "U" bolts to the torque figure given in General Data.

If the springs are disconnected, allow the car to stand on its wheels under its own weight, before tightening the shackle bolts.

**Rear axle breather**

The breather is housed under a domed cap situated on top of the axle casing to the right of the differential housing. (See Fig. 1, item 2).