

# Valmet

## Technical Paper Series

## Rebuilding for Safety

### Executive Summary

Rebuilding a machine line strictly for safety reasons is not unheard of, however safety improvement is typically one of multiple reasons for investing in a rebuild. Responsible OEMs constantly look for ways to improve the design of their equipment that will increase safety by reducing operator involvement in the pulp, board, paper and tissue making process.

Similarly, OEMs bring this design expertise into the field by implementing the latest technology to improve operator safety with small to medium sized rebuilds. The same equipment that automates a machine, with proper interlocks, training, and choice of materials, will typically increase operator and equipment safety as part of the overall rebuild.

This paper briefly describes designing-in safety, from the point of view of a winder. Discussion then continues with several case studies of designed-in safety across varying grades and machine sections.

## Operator safety is the #1 design criterion

Efficiency, speed, reliability – all important factors in papermaking equipment design. But the most important design factor is operator safety. A responsible manufacturer always makes sure that predominating safety directives are carefully followed, or exceeded, when designing new equipment. Whether the governing body of law is USA Standards 29 CFR, PART 1910 (Occupational Safety and Health Standards) or EC Machinery Directives.

For example, the revised EC Machinery Directive 2006/42/EC compels manufacturers to further increase the safety level of machinery and equipment sold within the European Union. It clarifies the machinery manufacturer's responsibilities and procedures to guarantee the safety of machines. In addition to these new manufacturer obligations, the new directive also urges users to improve the safety of their existing machines. The same standards should be met regardless of delivery country, as many key European standards have become international ISO standards.

Safety by design encourages engineers to remove safety risks during machinery development. In some countries designers are legally bound to remove risks and not just improve quality and increase cost savings.

As equipment safety standards are updated and increased, machines no longer automatically fulfill all of the requirements of the latest directives. Instead, their safety must be reassessed. Valmet has taken into account the additional requirements of the latest standards, such as risk assessment, assembly of machines and instructions, and has applied them to its operations accordingly.



*Figure 1. Due to a high level of automation, the level of protection in Valmet's machines is high. Safety has been integrated into the machine controls and machine design.*

## Risk assessment is very important

Ensuring the safety of winders or other paper finishing machines is especially challenging. In spite of a high automation level, the operation always includes manual intervention into the machine, which can lead to hazardous situations. Risk assessment is needed to control these risks. It includes all phases of the machine's life cycle and all the tasks carried out manually. If the machine design is based on incomplete risk assessment, accidents cannot be prevented because of the remaining hidden risks.

A comprehensive risk assessment requires multiple skills: know-how of machine design and experience in using the machine. The new risk assessment standards ISO 14121-1 and -2 recommend that a group of experts should be set up for risk assessment. In addition to technicians, it should also include machine operators. Because of the global market, it is necessary today to obtain psychological and cultural knowledge of human behavior.

When it comes to the bottom line, the OEM is expected to design-in machine safety. First, all possible machine-related risks must be eliminated or minimized. Then all possible remaining risks are minimized

by safeguarding the operators from the equipment. After those two stages, it's up to the papermill management to make sure their employees are adequately trained to minimize any residual risks.

### **The same safety solutions – whether new or rebuilt equipment**

The safety of all machines, even the new ones, must be maintained and upgraded over the course of time. Technology is developing constantly, providing better possibilities to improve safety. Therefore, the safety characteristics of machines in use, not only the old machines but also new ones with the CE marking, must be assessed continuously and identified risks must be addressed.

In addition to continuous follow-up, it is necessary to regularly carry out more thorough safety reviews of the machines in use, which may even highlight the need to modify them. To help papermakers, Valmet provides extensive safety and risk analyses as well as safety audits for machines in use. Valmet uses the same state-of-the-art safety solutions when it rebuilds machines as it does when it builds new ones.

### **Safety is a team effort**

Operating modern, highly automated papermaking equipment requires much more technical knowledge than before and thus also more guidance in dealing with the safety of such complicated systems. An automatic machine carries out its programmed functions, and if the operator does not understand how the machine functions, it is very likely that he/she will sooner or later find himself/herself in a dangerous situation. Therefore, the automatic machines should be more protected than earlier. The first step is for OEMs to prevent these risks by updating the technical know-how of their designers. However, to further minimize risk, operators must be continuously trained – by mill safety management and, for example, via Valmet's training courses for operators.

According to Matti Sundquist, safety expert at Sundcon Oy, "Severe and lethal injuries caused by automated machines can be prevented through the skillful design and application of solutions presented in safety standards, with detailed knowledge of automated machine sequences and by following the instructions and using safe working methods."

The machine manufacturer, the mill (employer), and the operator each have their own responsibilities. The manufacturer is responsible for the manufacture of safe machinery, the mill is responsible for the reduction of residual risks, and the operator is responsible for his/her own safety when using the machine. No one is allowed to shirk his/her responsibilities. However, despite these separate responsibilities, safety is teamwork.

### **How does Valmet improve safety in a rebuild?**

There are many different methods of designing in safety into original equipment or as part of a rebuild. The most typical are: removing unsafe elements or movements, guarding unsafe areas, and removing the



*Figure 2. Safety experts Matti Sundquist and Reijo Laine perform a risk assessment as part of the winder design process.*

operator from unsafe areas. Typically, safety oriented rebuilds will address all three of these, with replaced equipment, additional equipment, automated functions and operator training.

For example, let's look at the slitter section of a winder as an 'unsafe area' in need of a rebuild. The most powerful way to improve slitter safety is - to NOT handle slitter blades. Now how can this be accomplished while still using very sharp and dangerous slitter blades for their needed purpose? (Much of the following information is covered in a more detailed fashion at the Slitter Management Program website.)

### Automate operators out of the machine area

One method of designing in safety as part of a slitter rebuild is to automate part or all of the slitter repositioning needed when changing from one set of roll widths to another. This can be accomplished with a combination of sensors, PLC and slitter equipment Valmet calls WindPosit. The slitter repositioning can be further combined with other set change automated functions, such as the measurement of core lengths, in order to keep winder operators out of the winder area entirely. It's even possible to automatically disengage certain slitters (when running several narrow rolls) for the last few wraps of the wound rolls. This helps keep narrow rolls together for further roll handling conveying and wrapping, avoiding unsafe roll movement further downstream. Thus the thoughtful application of available slitting automation tools and processes can improve safety in areas of your mill other than just the winder slitter section.

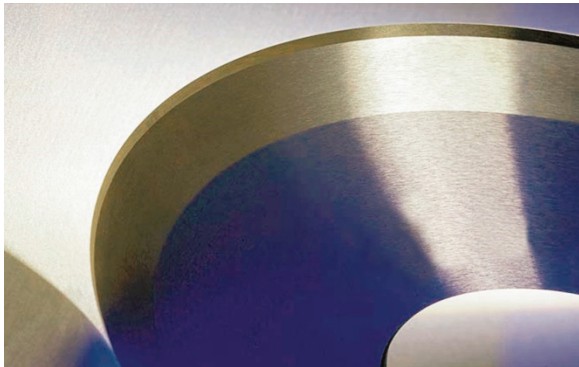

**Figure 3. Superfinished powdered metal blades and carbide bottom bands produce the cleanest, sharpest cutting edge possible.**

### Use newer materials and technology

Another slitter safety improvement method is to change the slitter blade material to long lasting powdered metal and using superfinishing for very sharp clean cutting edges. This, combined with the use of carbide bands, means your slitters will run much longer without needing to be changed out. Longer blade/band runtimes mean less frequent blade handling – a safer operation. (Similarly, on a papermachine the choice of roll cover, such as PressFox or VacuFox, will improve safety due to new adhesion technology that improves bonding and helps withstand aging effects of long-term use in wet and warm environments.)

### Add guards around dangerous areas

For consumables such as slitter blades, their guarding and safe transport are essential as parts of a safety upgrade. These are the easiest components of a rebuild to recognize as safety related as they are for a single purpose – improving operator safety. Other rebuild elements that improve safety may also improve runnability, efficiency, operating cost, etc – but personnel guards and accompanying safety interlocks have a sole purpose.

There are a multitude of safety guarding controls, ranging from fences and gates to light curtains and photocells. Tying these controls together to form interlocks that prevent machine movement when

operators are in an unsafe area is a key aspect of any PLC logic upgrade as part of a rebuild. The slitter section on a winder, for example, is just one 'safety zone,' representing an area that, depending on what the winder is doing at the time, is an unsafe area. Since there are multiple means of access to a given safety zone, there need to be multiple inputs into the PLC to interlock one or more of the area-specific machine movements.

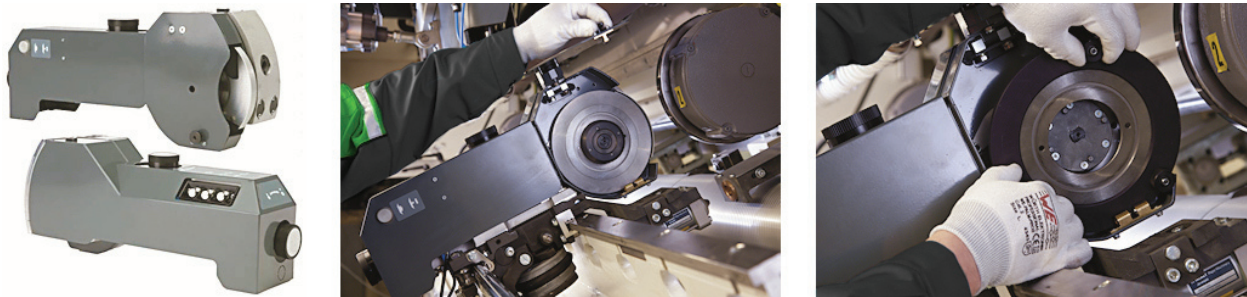

**Figure 4.** The new fully enclosed slitter holder(left) provides easy access to blades when needed (middle) and the latest QuickChange hub enables fast slitter changeouts safely using the slitter removal ring to protect operator fingers (right).

Valmet has recently developed a fully enclosed slitter holder. The casing helps guard against dangerous situations such as the top blade coming loose during operation. Encasing is done such that there is no need to open the cover during normal operation. The top blade is shielded to protect operators' fingers during web threading – the top slitter cutting edge is completely covered in its home position. Additionally, a mechanical brake stops the rotation of the top blade when the blade is not at its cutting position. (On a paper or board machine, adding nip guards is an example of protecting a dangerous area.)

### Transport and store dangerous materials in safe containers

Regarding transporting dangerous consumables, slitter blades can be stored in special containers (SlitterCarry) that can be rolled to the area where they will be used. Further, part of Valmet's BladePool service for providing a continuous supply of superfinished blades is new environmentally friendly packaging designed to protect operators' hands from sharp blade edges. The new corrugated packaging eliminates the need for petroleum based edge protection that would otherwise have to be cut off with a knife by the operators – with potential damage to the blade cutting surface, and a generally messy process. (A parallel on the papermachine would be a doctor blade local storage or un/reeling device such as BladeFeed and BladeCoiler, and a rolling blade storage unit such as BladeCarry.)



**Figure 5.** Storage and transportation methods such as SlitterCarry for slitter blades (left) and BladeStore and BladeCarry (middle) and BladeCoiler (right) for doctor blades improve the safety when operators handle and transport sharp consumables.

### Train your operators

Finally, the most important changeable factor in papermill safety is the knowledge and awareness of operators. Keeping machines and equipment in good shape is important but it's impossible to attain

highly efficient and safe production without competent and committed people. With training programs the skill level of your machine operators is maximized so that they are better able to manage your investment in the safest manner. For slitters, part of Valmet's Slitter Management Program is to provide complete slitting process training, both in the classroom and on-the-job. (See the SMP web site for more information about training availability and scope.) Training is also available for, and is generally a part of, all rebuilt sections of paper, board, tissue and pulp machines. This is especially important when the rebuild has changed the functionality of equipment with respect to what is expected of operators – frequently due to automated functions.

## Case studies of improving safety as part of a rebuild

The remainder of this paper will present several case studies on improving safety as part of a rebuild, covering multiple grades and machine sections. Though the equipment and application are different in each case, the methods and teamwork approach by mill and Valmet design personnel are similarly utilized.

In many cases, a safety rebuild was a result of an initial study of the process or machine section. For example, Valmet offers machine section process and condition tests, or safety audits such as a Yankee dryer safety inspection. Additionally, the air systems group from Valmet provides an environmental safety service to reduce dust and mist at your mill. Valmet has a comprehensive suite of analysis offerings to improve your operators' safety - whether it's a specific threading audit or a machine-wide safety audit.

### Pulp drying line automates threading system to improve safety

A pulp mill wished to improve safety and threading efficiency by automating their threading process. The mill would use two operators to thread from the pull stack to the cutter. One operator would lean over the pulper, rip the tail off the pull stack and run to the paper carrying roll. He would then reach over the carrying roll and hand the tail to a second operator who would throw the tail through a scanner and then into the nip of the cutter.

After looking at various options the mill chose to go with a multi-phase approach. The first installation phase added a FoilForce vacuum assisted belt threading unit after the carrying roll to eliminate the need for the second operator. This worked well by itself, making the process more forgiving for the single operator who was still required. In the second phase a TailShooter HW was installed between the pull stack and the carrying roll that automatically passed the tail through to the FoilForce unit. A drive was also added to the paper carrying roll to facilitate smooth transfer from the TailShooter to the subsequent FoilForce conveyor.

Another advantage of this configuration is that while threading with the TailShooterHW, the traversing system can be stopped at any point along the path to the tail thread lead roll, which

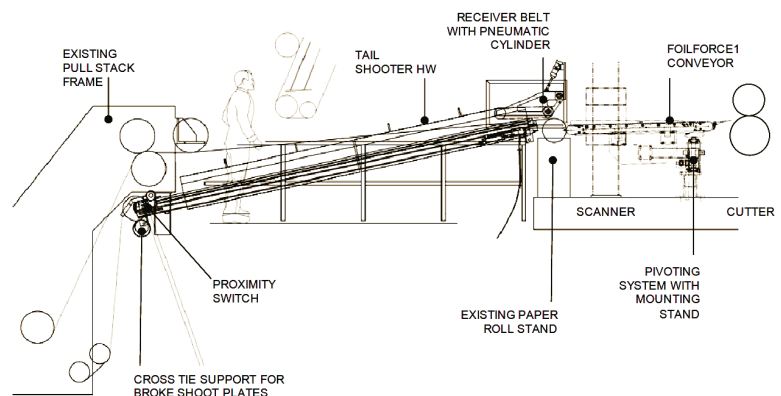
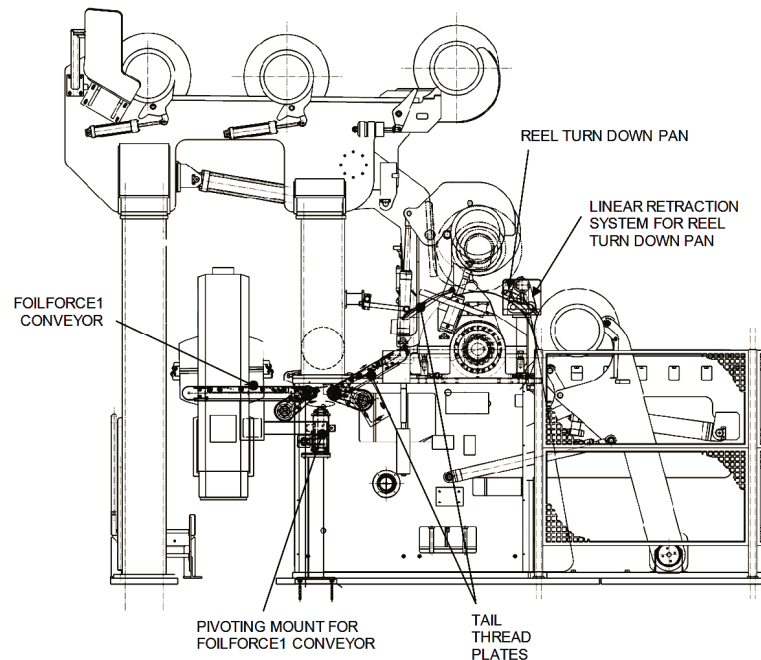

**Figure 6. Pull stack to cutter threading rebuild included TailShooter HW and FoilForce units, with a driven paper carrying roll.**

helps with threading of the tape by-pass system. After the tail is near the by-pass tape in-feed nip, the operator tears the tail and delivers the tail manually to the cutter by-pass rope in-feed nip.

The rebuild also included automation of part of the threading process from the calender to a reel spool resting on the rail. By adding two FoilForce units, a tail threading plate and a linear retracting reel turn down pan, the threading is much safer now, as well as being consistent from operator-to-operator and shift-to-shift. The operator only needs to sever the tail and place it onto the first FoilForce conveyor belt, after which the two conveyors and threading pans carry the tail to the nip created by the reel drum and spool on the rail. In all sections of the rebuild, the most cost efficient approach was used to improve safety by combining manual and automated functions.

In both threading areas, FoilForce units and other threading components will automatically move into and out of position where needed. This allows operators to access all necessary areas of the machine, and normal machine movements, such as scanner movement, to occur when not in a threading event.



**Figure 7.** Between the calender and reel spool there were two FoilForce conveyors and additional threading pans.

Other than fine tuning to handle varying moisture content and other grade specific variables, the system is working quite well and has provided the mill a much safer and more efficient working environment.

### Yankee head insulation improves safety and energy use at tissue mill

As a result of problems with fires caused by dust on the head of the yankee on their TM1, a tissue mill asked Valmet for help. The fires were difficult to handle due to the confined space, which made it even more of a major safety issue. The installation of a tailor made yankee head insulation covering from Valmet solved the problem and reduced their steam consumption significantly.

The main reason for the installation was to reduce problems with fires. According to mill management, "We had problems with potential of fires on the yankee shell caused by dust accumulation on the surface of the heads. Burning pieces of dust collection threatened to release during rotation of the yankee which could start fires close to the machine environment. We quenched the fires with hot water, but this placed dangerous stress on the yankee, which increased the danger to our employees. So, we had to prevent this issue."

Rising costs and saving energy are also big issues for the mill. The assistant mill manager said, "I suppose it's like that in every mill, so we found a 'two-in-one' solution. We decided to install yankee head insulation from Valmet." Valmet's installation of a compact metal insulating cover prevents steam from

leaking out as well as dust from coming in to the hot yankee head. The technique solves the energy problem and eliminates the risk of fires.

Valmet's yankee head insulation consists of insulated plates attached to the yankee head which can easily be removed for inspection and with one covered opening for easy access to the manhole cover. The material used is of high quality for maximum performance and minimum deterioration due to ageing and facilitates long-term use with minimum maintenance.

The installation was done during the annual shutdown. The work was performed by three people from Valmet and went on without any problems, thanks to good advanced communication and preparations before the installation.

Mill management reported that, "Two months after the installation of the the yankee head insulation we have not had any fire incident on yankee heads." And related to energy conservation, they reported, "If we compare steam consumption with the most similar condition on machine, before and after installation of the yankee head insulation; in our case the reduction in steam consumption exceeded 6% or 70 kWh/ton produced tissue paper".

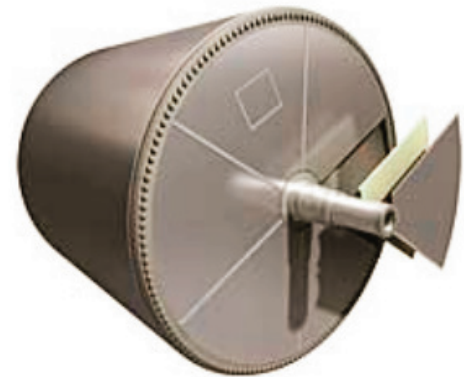

**Figure 8. Tissue machine (left) reduced fires after Valmet yankee (right) received the new head covering, thereby increasing safety while reducing energy costs.**

### **Valmet partners with board mill to improve product quality and operator safety**

At a US board mill, personnel were tired of changing blades frequently and still ending up with less than acceptable roll edge quality. Additionally, frequent blade handling meant more opportunities for accidents with sharp blade edges. After learning that Valmet's Slitter Management Program would address these and other issues, they decided to give SMP a try. Valmet was called in to help improve operator safety and the product quality delivered to their customers.

Before the Valmet slitting technician arrived, the mill had been changing out a set of blades each week and slitter bands every other week. It was very important to this mill to provide the highest quality to their customers, thus the frequent changeouts. The mill was also using an outside supplier for grinding, but the blades were not being superfinished. At that time, the blades were industry standard powdered metal blades with 10% vanadium, paired with carbide bottom bands.

Upon arrival, the Valmet SMP technician discussed which aspects of the Slitter Management Program would most help mill operations and personnel. For this particular mill, the greatest benefits would occur with a comprehensive review of blade and band material and usage, as well as operator procedural changes.



After reviewing the relative merits of different blade materials, the mill chose to upgrade to Valmet's newly developed material containing 15% vanadium. This combined extreme edge strength with an improved ability to polish the blade edge. In addition to improving the blade materials, Valmet SMP personnel provided on-site hands-on training in the optimal way to setup and operate blades and bands. Improving operational safety is an integral element of Slitter Management Program training.



**Figure 9. A combination of slitter handling training and new technology blade materials improved operator safety and increased efficiency at this board mill.**

The most obvious result is higher roll quality being shipped. And this quality is being sustained with blades that now operate for 8 weeks and bands that last 16 weeks. Additionally, operator safety and blade/band organization have also improved. There is measurably safer slitter handling taking place after SMP training. Winder equipment is also less likely to be damaged by poorly maintained and maladjusted slitters.

The absolute safest way to handle a slitter blade is to NOT handle a slitter blade. Since the new blade material and properly setup blades and bands combine to greatly extend slitter lifetime between grindings - there is much less frequent blade handling needed. Operator exposure to slitters has reduced considerably, thereby increasing safety.

Valmet SMP personnel now visit the mill monthly to exchange the dull slitter blades for sharp slitter blades. This further guarantees roll quality by making sure there is no need to run unnecessarily dull blades.

## Papermachine disturbances cause dangerous vibration at the winder

A paper mill had a very serious safety concern with a winder that would, with increasing frequency, vibrate so hard that it would throw a roll off the winder into the air. They needed to know what caused the winder to vibrate. So the mill contacted Valmet in Norcross, GA for assistance.

The mill sent an MD roll to be tested for periodic variation that might be the cause. Thickness differences in paper are often the cause of excessive vibration. The source of these differences could be due to weight differences or just thickness. Therefore, Valmet looked at basis weight and caliper to try to pinpoint a possible cause.

First, experts looked at the basis weight spectrum, but there were no significant peaks. However, when they looked at the caliper spectrum, they saw several serious peaks.

These disturbances happened after the web was formed, often from a press, dryer, or calender roll.



**Figure 10. Valmet used a Tapio Analyzer (profiling) combined with state-of-the-art testing and analysis equipment acquired from the Beloit Rockton R&D Center.**

The tallest peak is at 3.296 Hz, which at machine speed corresponds to a roll with 72" diameter. The dryer cans on this machine have 72" diameters. The peaks at 6.5 Hz, 9.9 Hz, 13.1 Hz, and 21.1 Hz are harmonics of the 3.296-Hz peak.

The second tallest peak, at 14.11 Hz is the double harmonic of 7.0 Hz. At machine speed, this corresponds to a roll with 34" diameter. The king calender roll on this machine has 34" diameter.

Another serious peak is at 17.09 Hz, which is the double harmonic of 8.5, matching a roll with 28" diameter. The other calender rolls on this machine have 28" diameters.

This left a lot of rolls to check for vibration, misalignment, out-of-roundness, bad bearings, etc. But, the safety issue of roll throwouts could be deadly and was worth the time to determine and fix the cause.

In this case study, using Valmet allowed the mill to expand the scope of their own mill testing and analysis without having to invest in advanced testing tools, thereby improving operator safety.

### Environmental dust problems solved at laminating paper mill

The base paper produced on PM1 at a laminating paper mill is porous because it is impregnated with resin used in laminate production. Before the installation of the new dust control systems there were problems with dust, particularly in winding. After winding, some of the dust remained between the paper sheets and some accumulated on the machine frame and fell onto the paper. During the subsequent impregnation process dust got mixed with resin and clogged the filters, impairing the impregnation properties of the resin. This led to extra costs due to management of waste resin.

In addition to quality reasons, occupational safety and health reasons also spoke for better dust control. The winder area used to be cleaned with pressurized air. Due to the cleaning method, clouds of fiber dust

rose in the air and employees needed respiratory masks in order to work in the area. The old winder had two built-in suction exhausts, but they were not sufficiently efficient.

"When making the investment decision, we found Valmet offered the most interesting

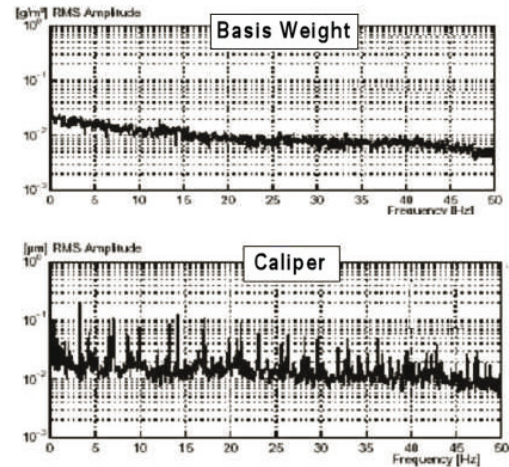

**Figure 11.** The mill's paper samples were processed by Valmet personnel, producing the frequency spectrum charts which they then analyzed further.

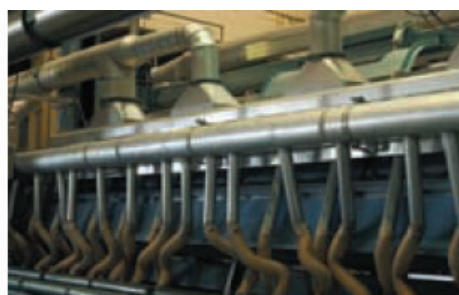

**Figure 12.** The new on- and off-sheet dust control systems on PM1 have worked to the satisfaction of both the mill operating personnel and the mill's customers.

options because of the great number of references and their in-depth knowledge of dust removal," explained the PM1 production manager. Also, Valmet's dust removal operating principle had already been tested and proven at other of his company's mills.

New winder area dust control systems were installed in a month's shutdown with a new winder installation. The equipment included two on-sheet dust removal boxes and two off-sheet dust removal boxes, a supply air unit, a dust separator, duct work and automation.

The on-sheet dust control system led to improved quality for further processing, better working environment due to improved air quality and a reduced need for cleaning and maintenance. The off-sheet dust control system, in turn, reduced the risk of fire or dust explosion.

According to the production engineer, the equipment has worked well: "The amount of dust on the floor is now low and no dust is accumulated on the winder beams. The winder area is still cleaned with pressurized air once a shift as before, but the amount of dust is now considerably lower." Satisfaction has also been shown by PM1's customers, who have not reported any dust-related problems after the installation.

### **Carton-board mill improves winder safety**

In order to improve safety at a carton-board mill, it was decided to rebuild the (non-Valmet) machine winder. The Valmet rebuild delivered an increase in safety and production capacity and a better winding process.

Mill management decided to rebuild the winder to eliminate manual set changes as part of a major project to improve safety. Switching to automatic set changes meant considerable modifications to the machine. "We chose to give the order to Valmet because our emphasis was on safety and they were able to guarantee a high safety level and a set change time of less than 84 seconds," said the mill's rebuild project manager.

The safety improvement work was divided into two steps. The first involved rebuilding the control system and modernizing the rider roll system. This was done at the same time preparations were made to install an automatic set change system. Stage two involved the roll pusher, web holder and web cutter with counter blade being replaced. New functions for core gluing and core feeding were installed, as was a new suspension device for end gluing. The set change operation was also changed from manual to fully automatic.

The result has significantly improved operator safety, as no manual handling is required during set changes. The rebuild also made it possible to eject smaller rolls than before, which has eliminated the need to splice an existing roll in the event of a sheet break. Once the final adjustments and optimization of all sequences had been completed, the rebuilt winder was ready to start up.



**Figure 13. The rebuild improved safety by increasing the level of automation, moving the operator out of the machine area as much as possible.**

"After a somewhat slow start with a few teething problems in the control system, the machine came right and has now been running very well. However, we did experience some issues after two weeks of production when changing from coated to uncoated grades," said the project manager. "Today, I can definitely say that all our expectations for the rebuild have been more than fulfilled. Winder safety has improved considerably, and we are extremely satisfied with the positive effects of our safety improvement project. Our production capacity has also increased because of the shorter set change time, and we achieved the guaranteed set change time quite easily. Today, set change takes just 80 seconds or so, whereas earlier it took approximately 150 seconds. In fact, the set changes are even quicker than for the much newer [winder], which was installed in 1996. Further improvement could also be seen once the new hydraulically-controlled rider roll and the new control system were installed – the winding process is now working better and more smoothly than before," reported the project manager.

## Summary

The tough market situation affecting the paper industry means much tighter investment budgets and fewer resources generally. So rebuilding a machine section can, in many cases, prove a more cost-effective option than investing in a brand new machine. Rebuilding bit-by-bit will eventually result in fully modernized and safer machinery and systems.

The foregoing case studies provide a few examples of different safety rebuilds that Valmet has provided for various mills. Whether your safety issue is large or small, a combination of training, new materials, new guarding/interlocks, additional automation and modernized equipment can and will improve your operator safety. Using the same techniques and design expertise, Valmet can work with mill management, maintenance personnel and operators to design-in the most effective safety improvements on any section of your machine line.

*This white paper combines technical information obtained from Valmet personnel and published Valmet articles and papers.*

*Valmet provides competitive technologies and services to the pulp, energy and paper industries. Valmet's pulp, paper and power professionals specialize in processes, machinery, equipment, services, paper machine clothing and filter fabrics. Our offering and experience cover the entire process life cycle including new production lines, rebuilds and services.*

*We are committed to moving our customers' performance forward.*