

# EEE3441 Electrical Machines

## Department of Electrical Engineering

### | Lecture |

# Introduction to Electrical Machines

## In this Lecture .....

Induction motors and synchronous machines are introduced

- Production of rotating magnetic field
- Three-phase Induction motors
  - Construction & operating principles
  - Slip
  - Characteristics & starting methods
- Three-phase synchronous machines
  - Construction & operating principles
  - Characteristics

## Production of Rotating Magnetic Field

- *Rotating Magnetic Field* is very important to the operation of electrical machines, especially for 3-phase induction motor, and it is produced by three-phase voltages
- Three phase voltages has a phase displacement of  $120^\circ$ , hence at any instant of time there is a different voltage values in the three phases
- The three phase voltage is sinusoidal in waveform
- Let us examine one complete cycle of a very low frequency three phase voltage (period  $T = 360$  seconds), at an interval of  $30^\circ$  electrical degrees, and we tabulate the three phase voltages in the following table:

# Instantaneous Values of 3- $\phi$ Voltages

Time	angle	<i>3 Phase Voltage (Volts)</i>		
		<i>Red Phase</i>	<i>Yellow phase</i>	<i>Blue Phase</i>
0	0	0	-86.6	86.6
1	30	50	-100	50
2	60	86.6	-86.6	0
3	90	100	-50	-50
4	120	86.6	0	-86.6
5	150	50	50	-100
6	180	0	86.6	-86.6
7	210	-50	100	-50
8	240	-86.6	86.6	0
9	270	-100	50	50
10	300	-86.6	0	86.6
11	330	-50	-50	100
12	360	0	-86.6	86.6

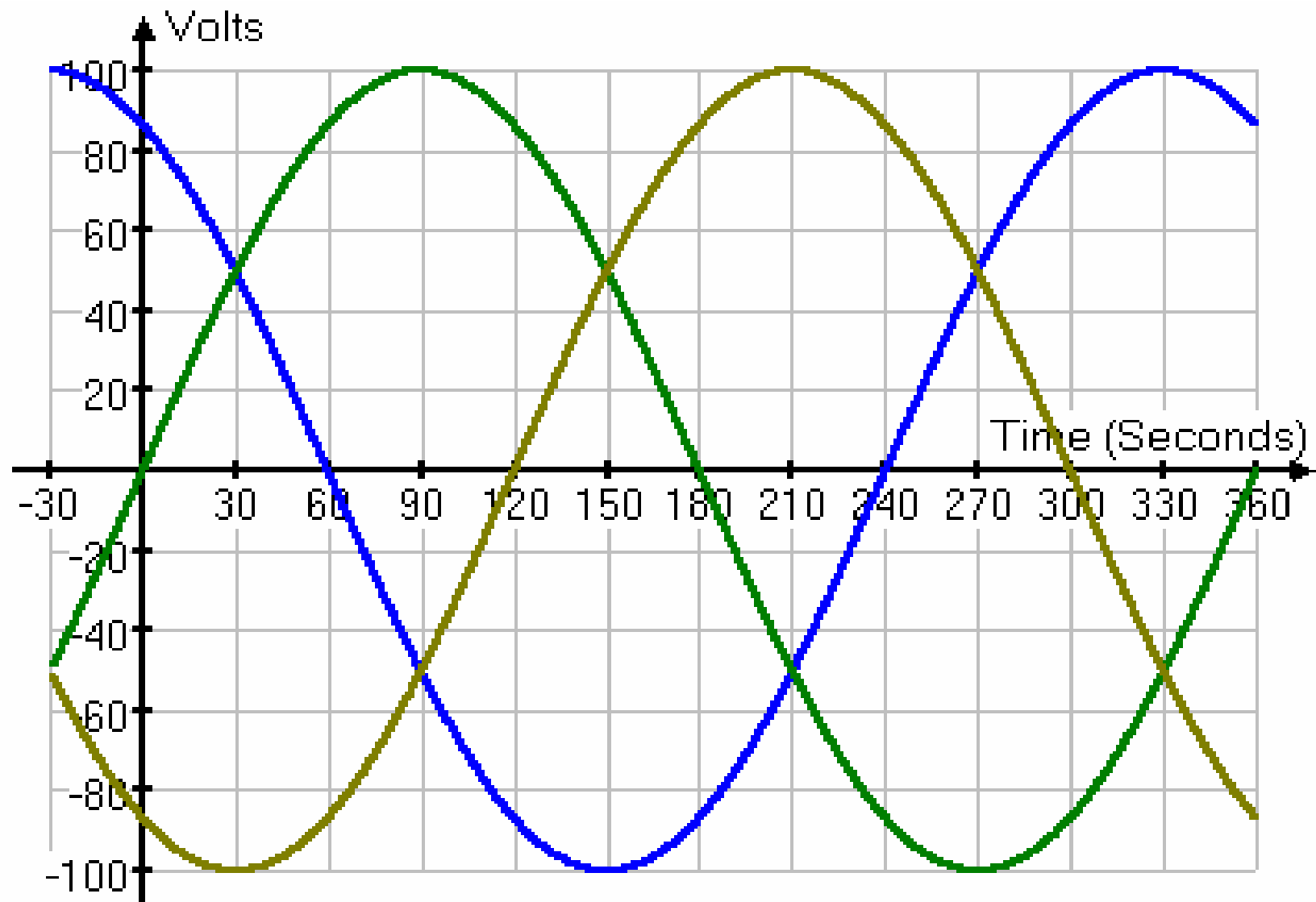

Magnetic Field produced by three phase currents when 3 phase voltage is applied to the stator of a 2-pole induction motor

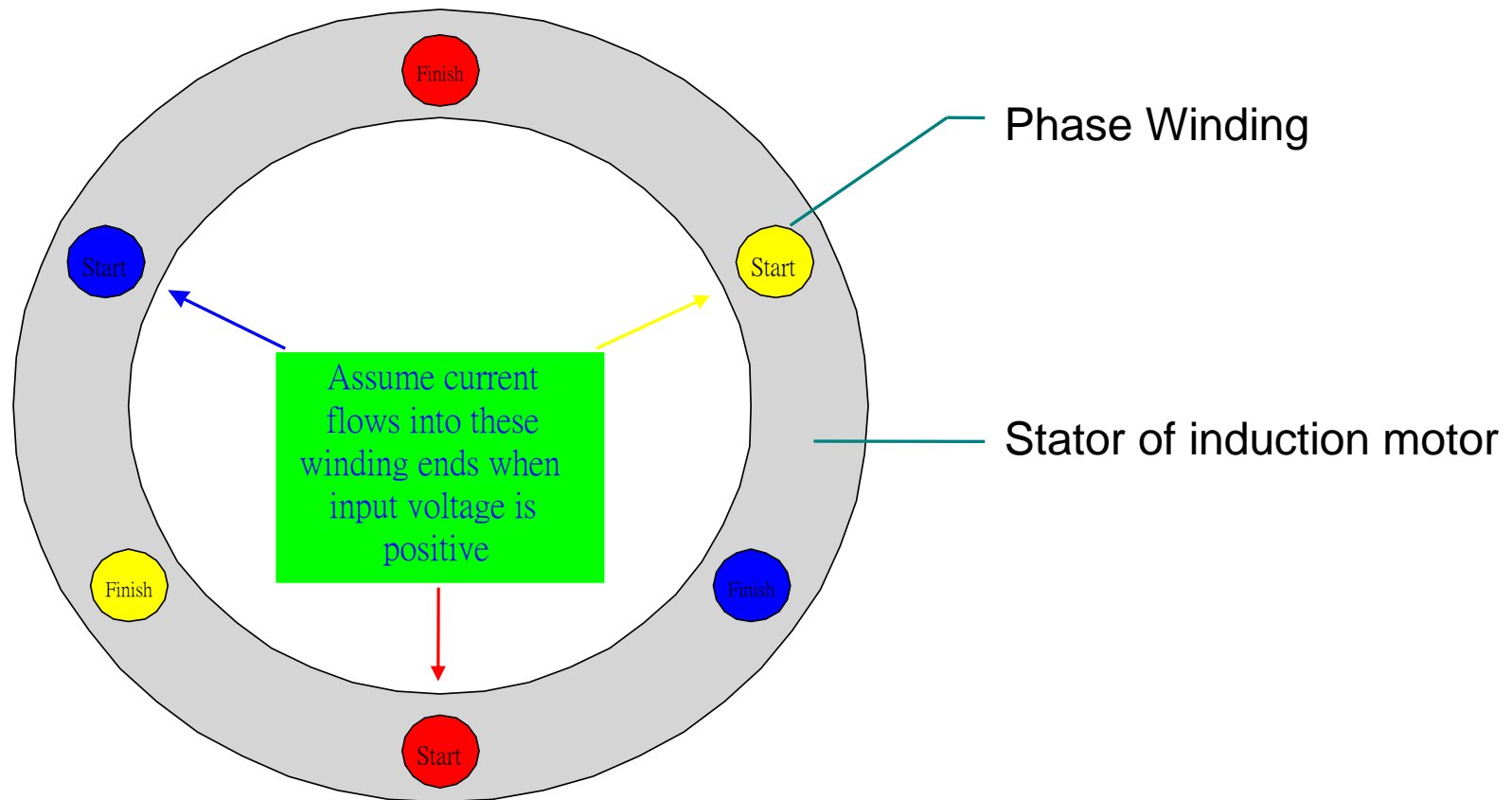

# Magnetic Field produced in a 2-pole induction motor (1/13)

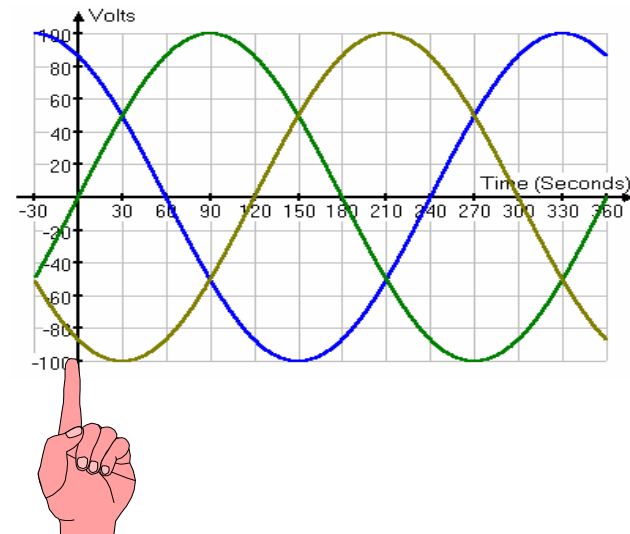
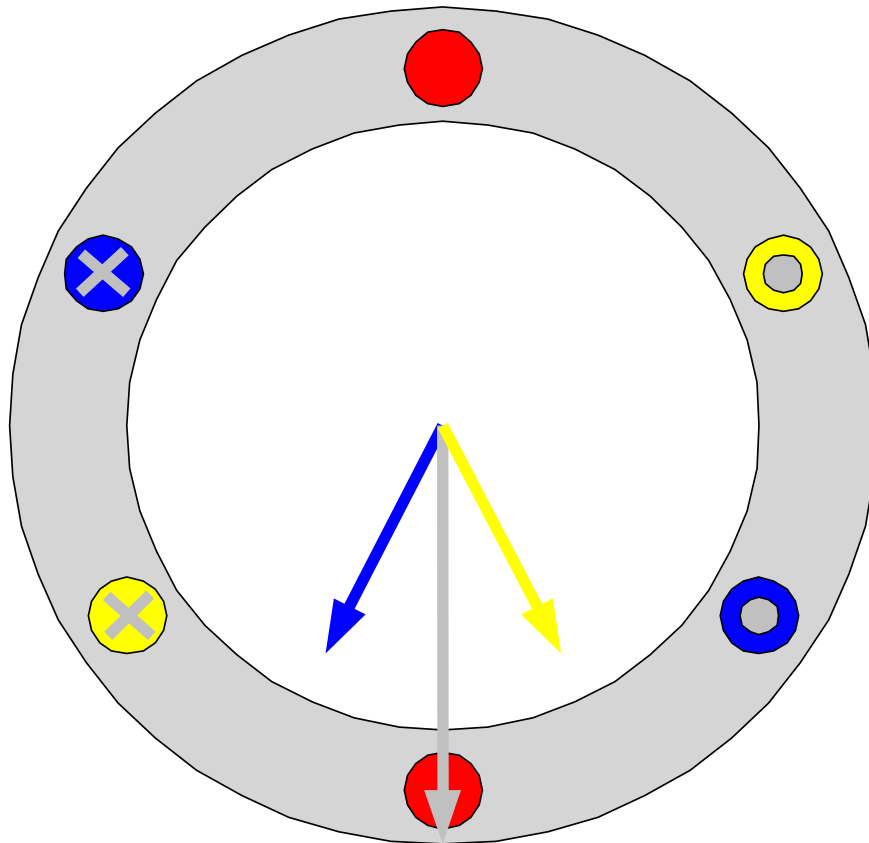

Time :  $t = 0$

Red phase = 0 V

Yellow Phase = -86.6 V

Blue Phase = +86.6 V

## Magnetic Field produced in a 2-pole induction motor (2/13)

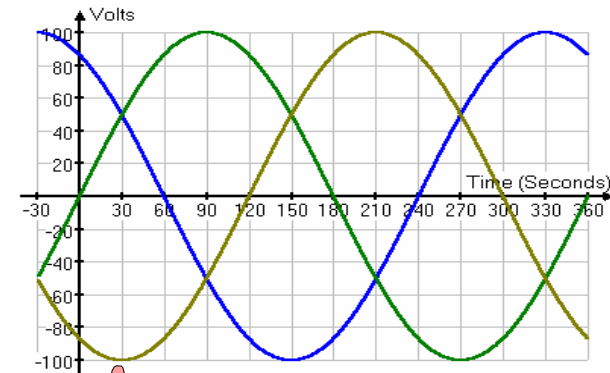
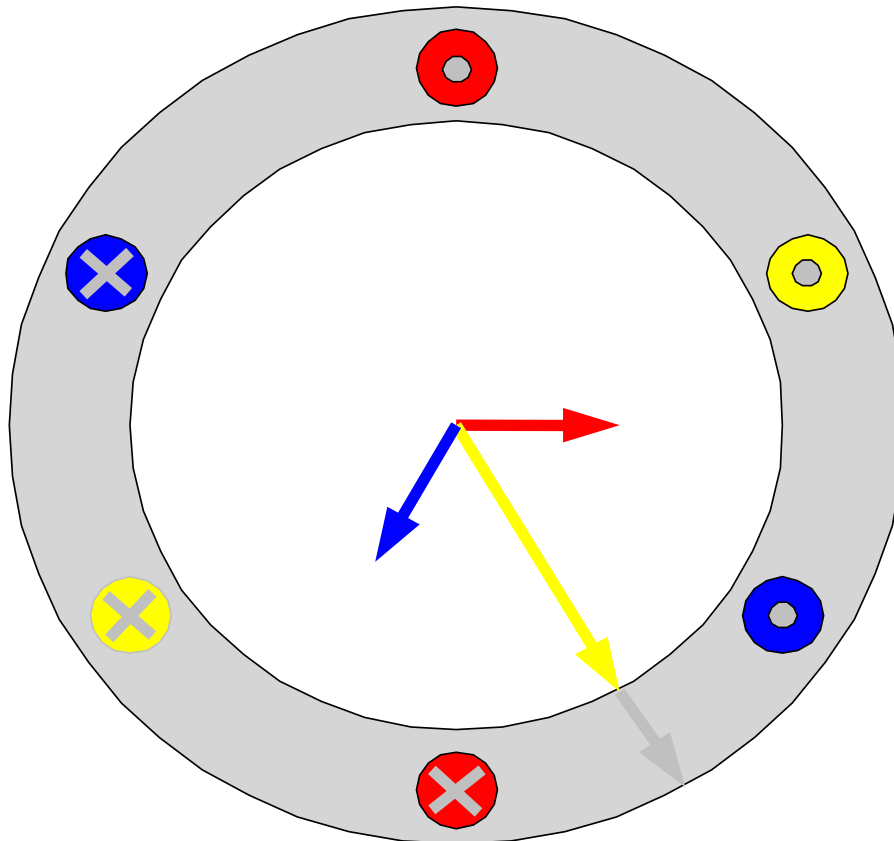

Time :  $t = 30 \text{ Sec}$

**Red phase** = 50 V

**Yellow Phase** = - 100 V

**Blue Phase** = + 50 V



# Magnetic Field produced in a 2-pole induction motor (3/13)

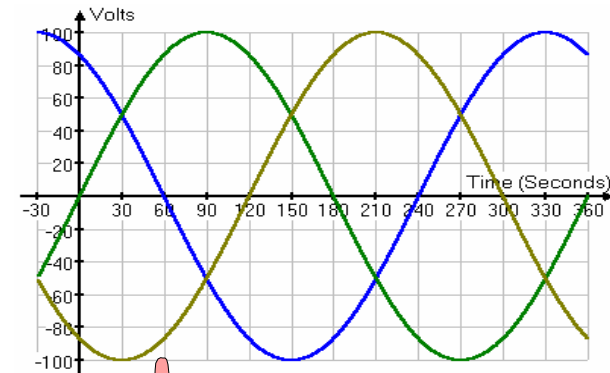
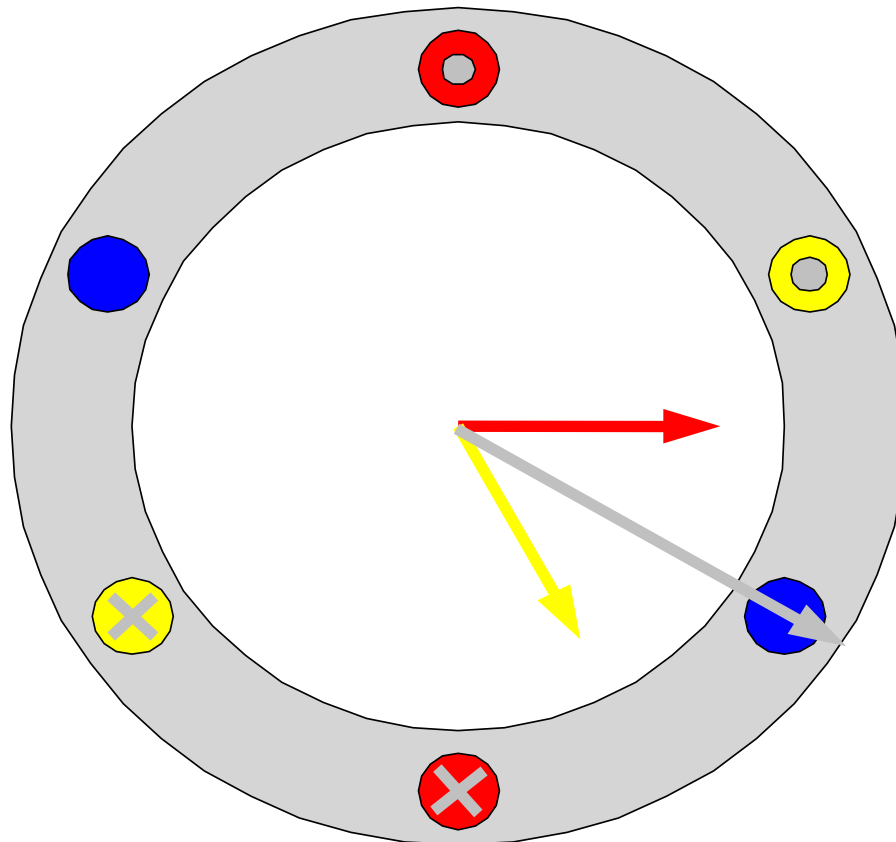

Time :  $t = 60 \text{ sec}$

Red phase = +86.6 V

Yellow Phase = -86.6 V

Blue Phase = 0 V

## Magnetic Field produced in a 2-pole induction motor (4/13)

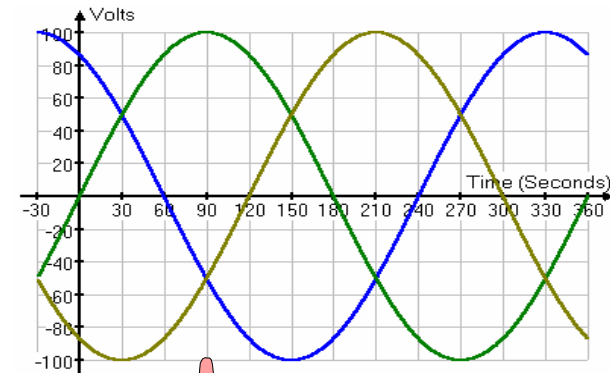
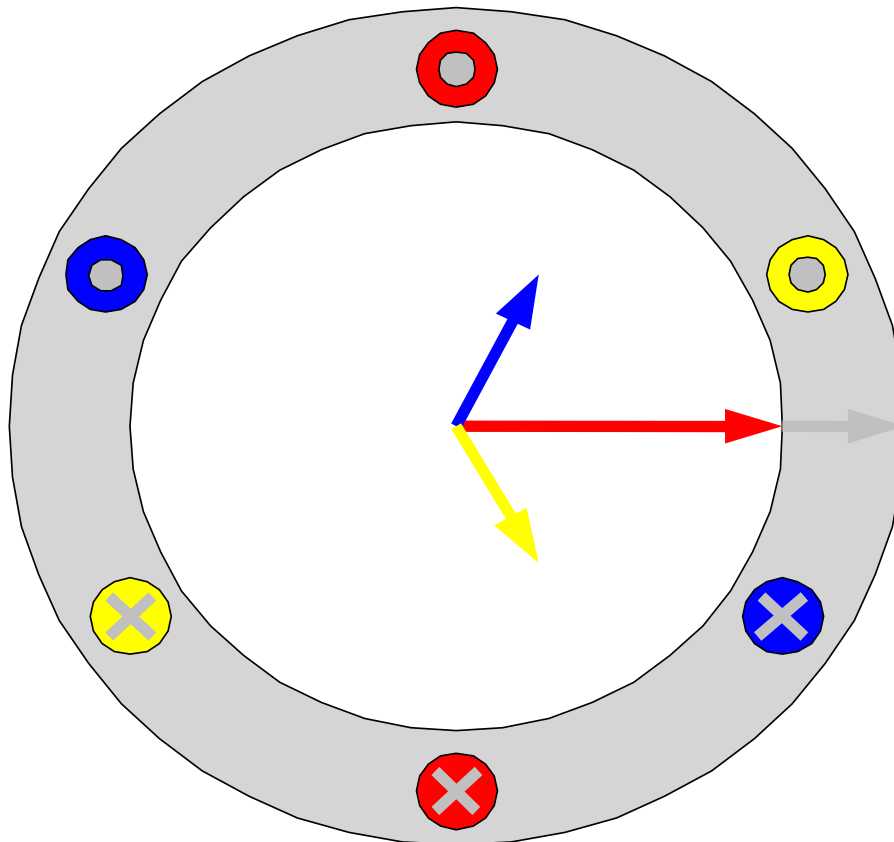

Time :  $t = 90 \text{ sec}$

**Red phase** = +100 V

**Yellow Phase** = - 50 V

**Blue Phase** = - 50 V

## Magnetic Field produced in a 2-pole induction motor (5/13)

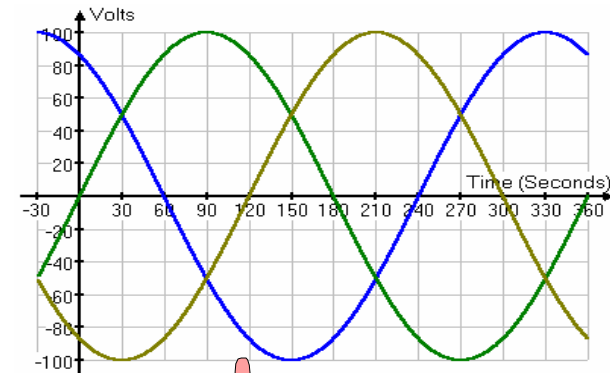
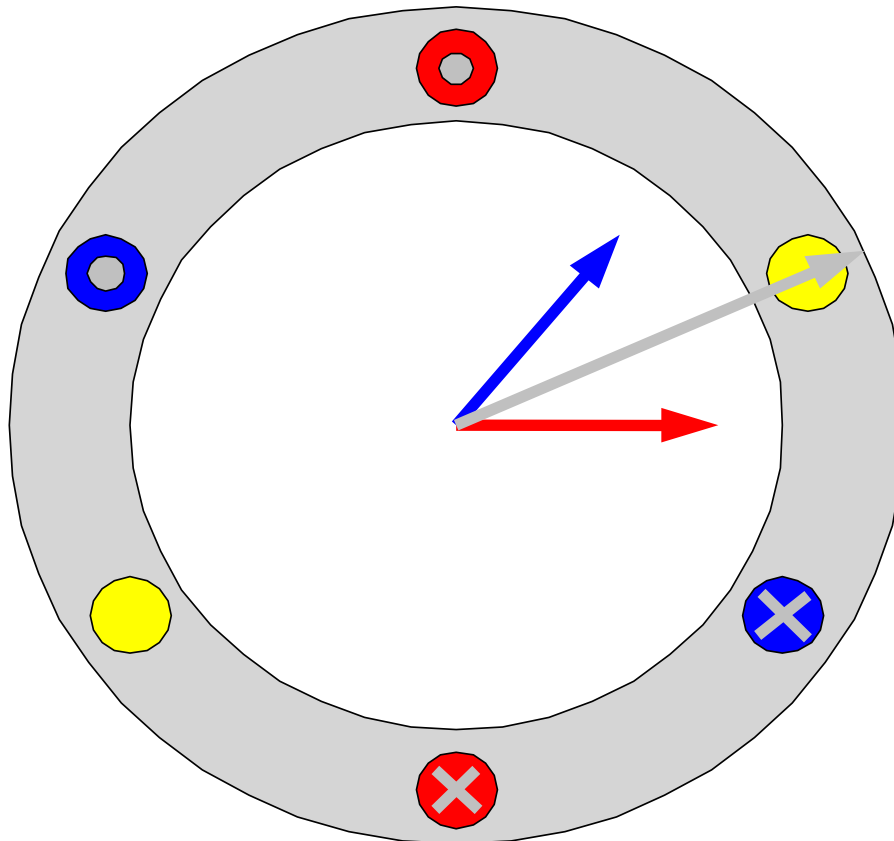

Time :  $t = 120 \text{ sec}$

Red phase = +86.6 V

Yellow Phase = 0 V

Blue Phase = -86.6 V

# Magnetic Field produced in a 2-pole induction motor (6/13)

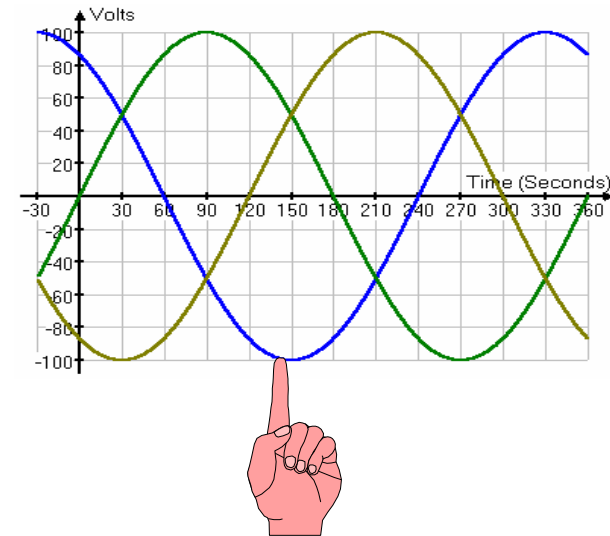
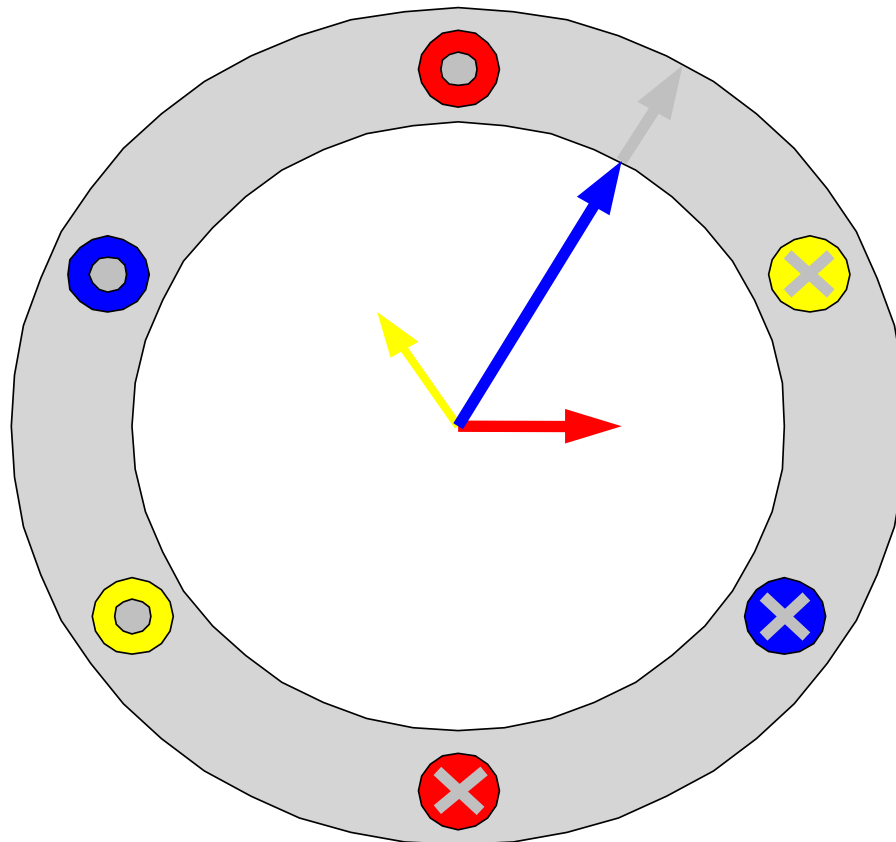

Time :  $t = 150 \text{ sec}$

Red phase = +50 V

Yellow Phase = +50 V

Blue Phase = -100 V

## Magnetic Field produced in a 2-pole induction motor (7/13)

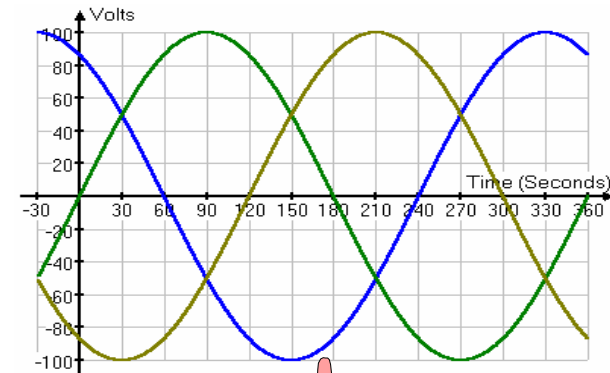
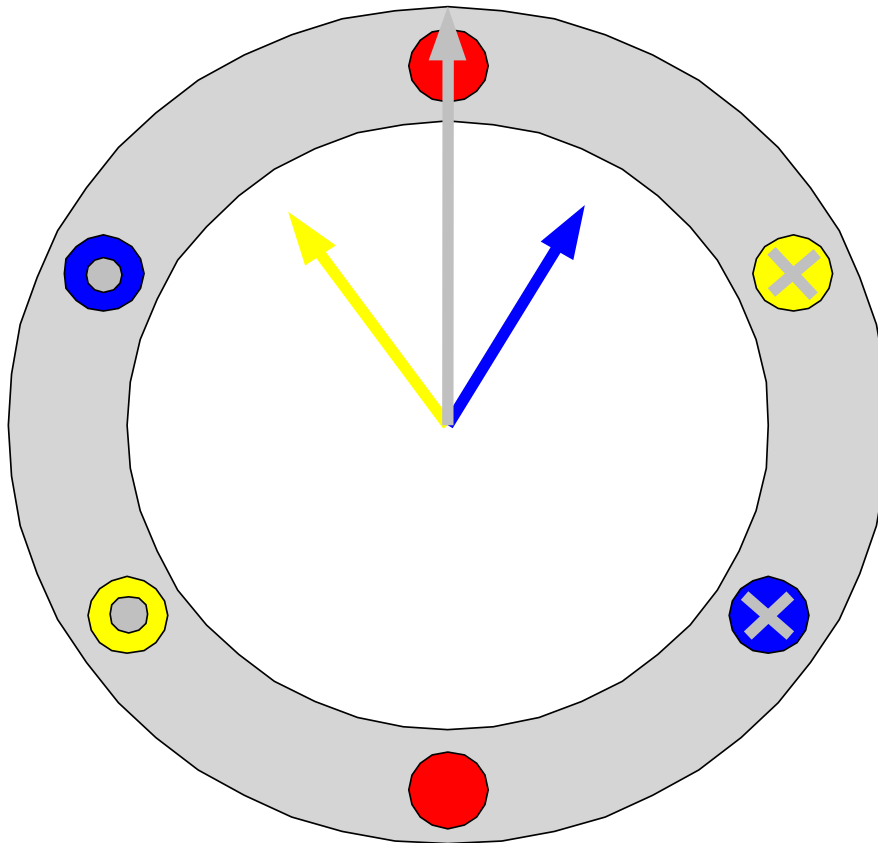

Time :  $t = 180 \text{ sec}$

Red phase = 0 V

Yellow Phase = +86.6 V

Blue Phase = -86.6 V

# Magnetic Field produced in a 2-pole induction motor (8/13)

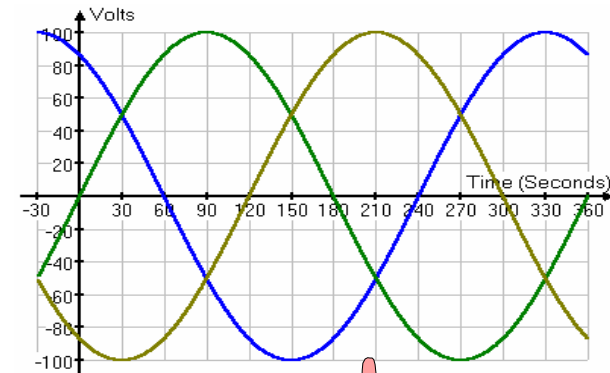
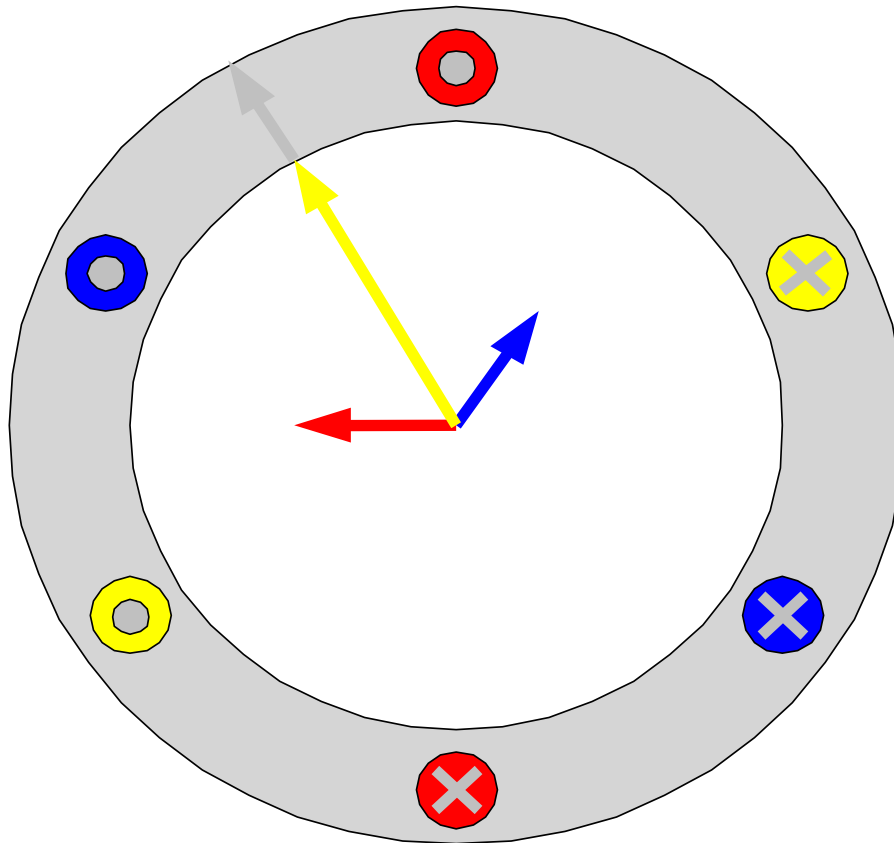

Time :  $t = 210 \text{ sec}$

Red phase = -50 V

Yellow Phase = +100 V

Blue Phase = -50 V

## Magnetic Field produced in a 2-pole induction motor (9/13)

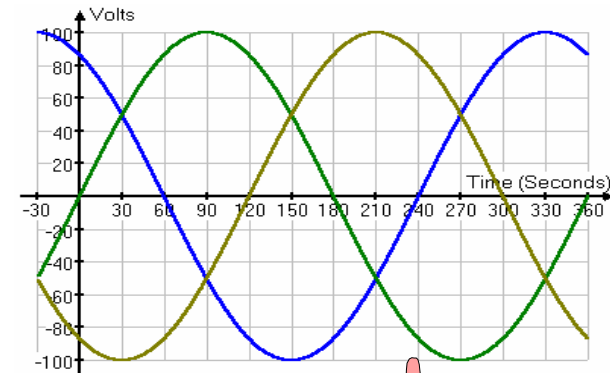
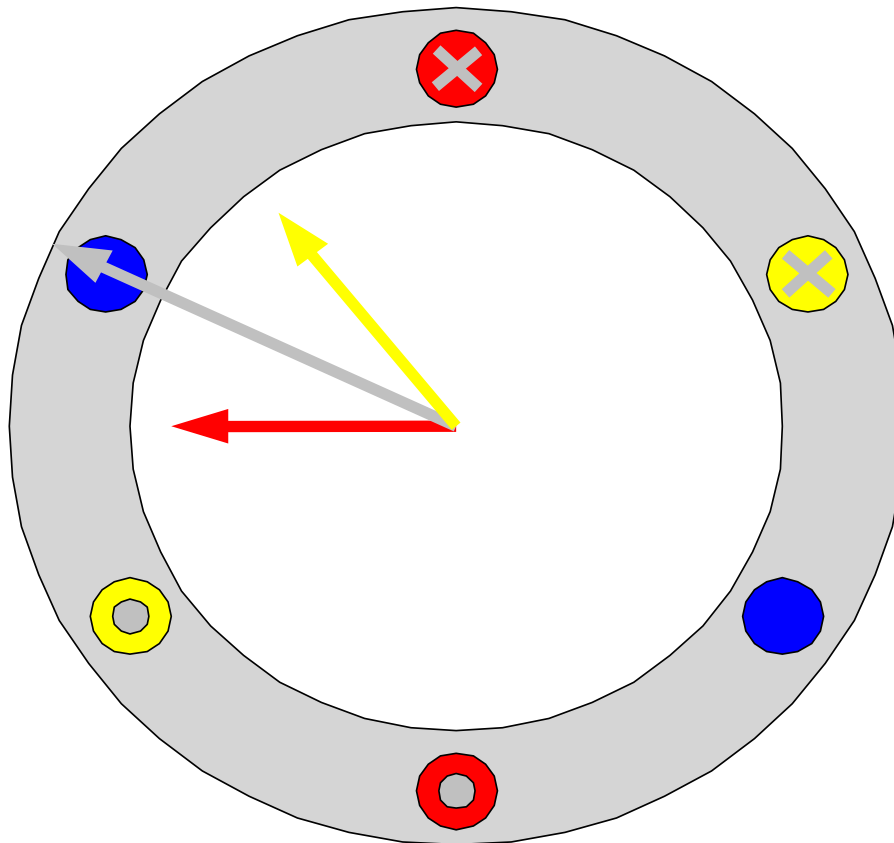

Time :  $t = 240 \text{ sec}$

**Red phase** = -86.6 V

**Yellow Phase** = +86.6 V

**Blue Phase** = 0 V

# Magnetic Field produced in a 2-pole induction motor (10/13)

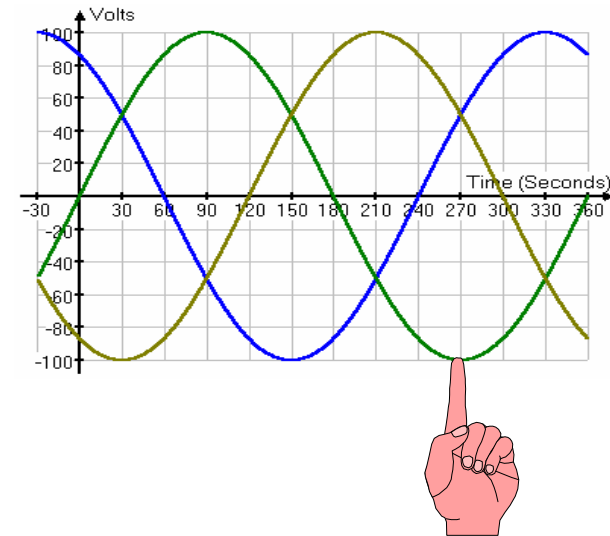
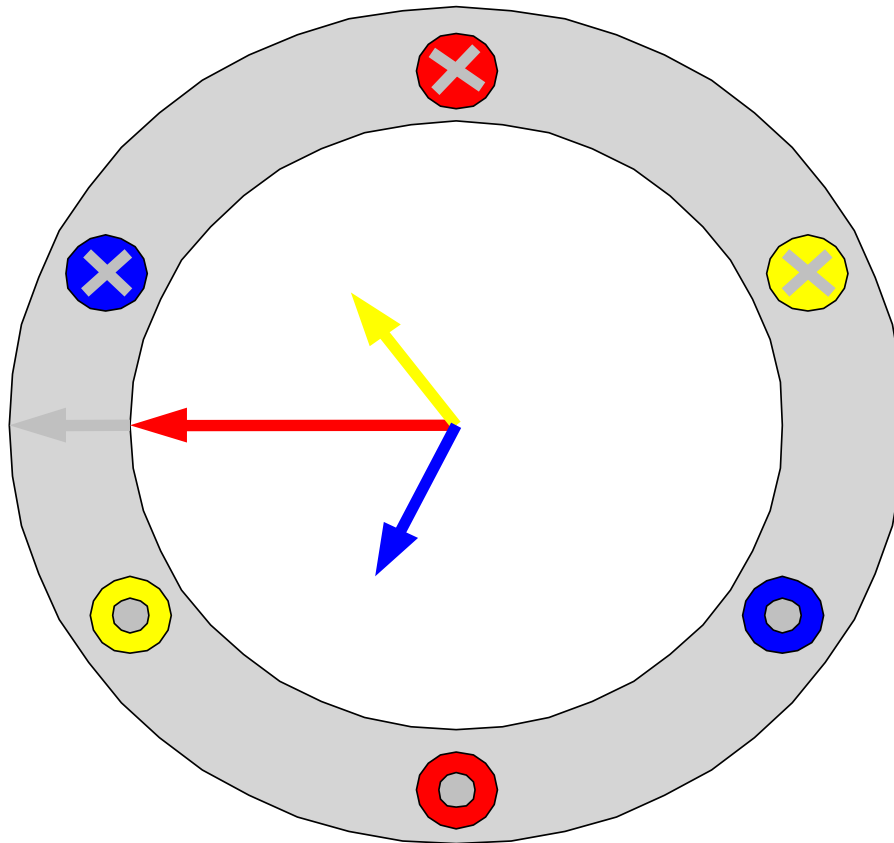

Time :  $t = 270 \text{ sec}$

Red phase = -100 V

Yellow Phase = +50 V

Blue Phase = +50 V



# Magnetic Field produced in a 2-pole induction motor (11/13)

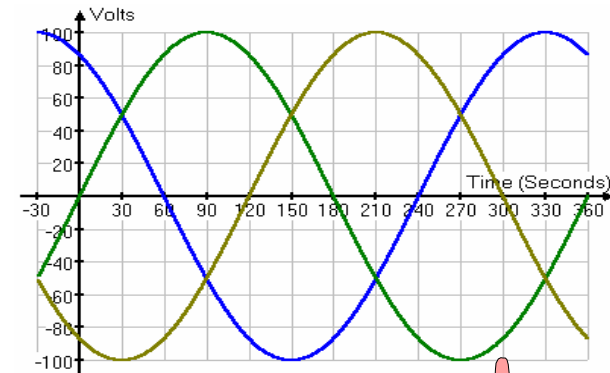
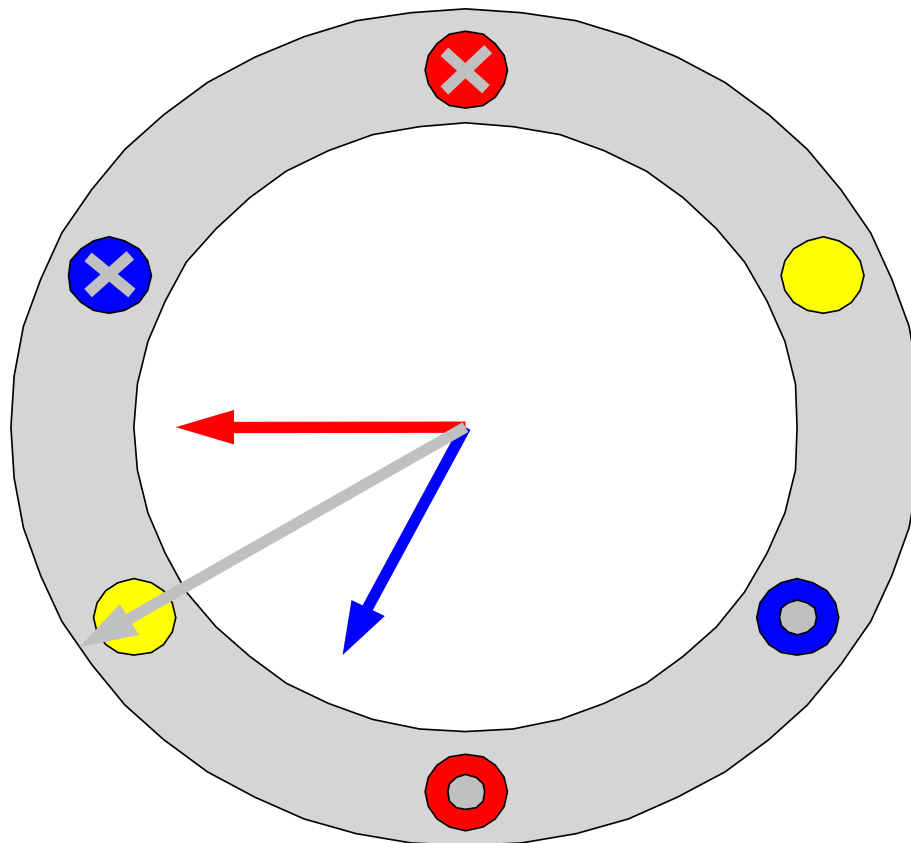

Time :  $t = 300 \text{ sec}$

Red phase = -86.6 V  
 Yellow Phase = 0 V  
 Blue Phase = +86.6 V

# Magnetic Field produced in a 2-pole induction motor (12/13)

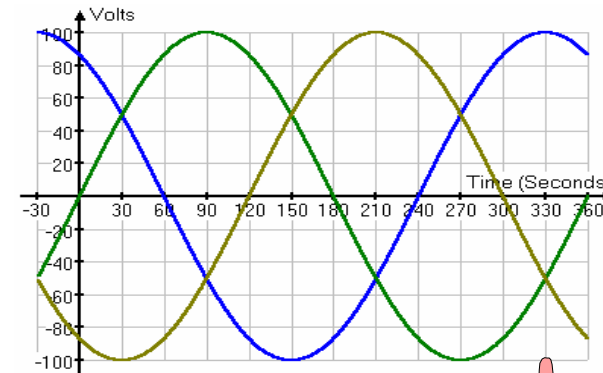
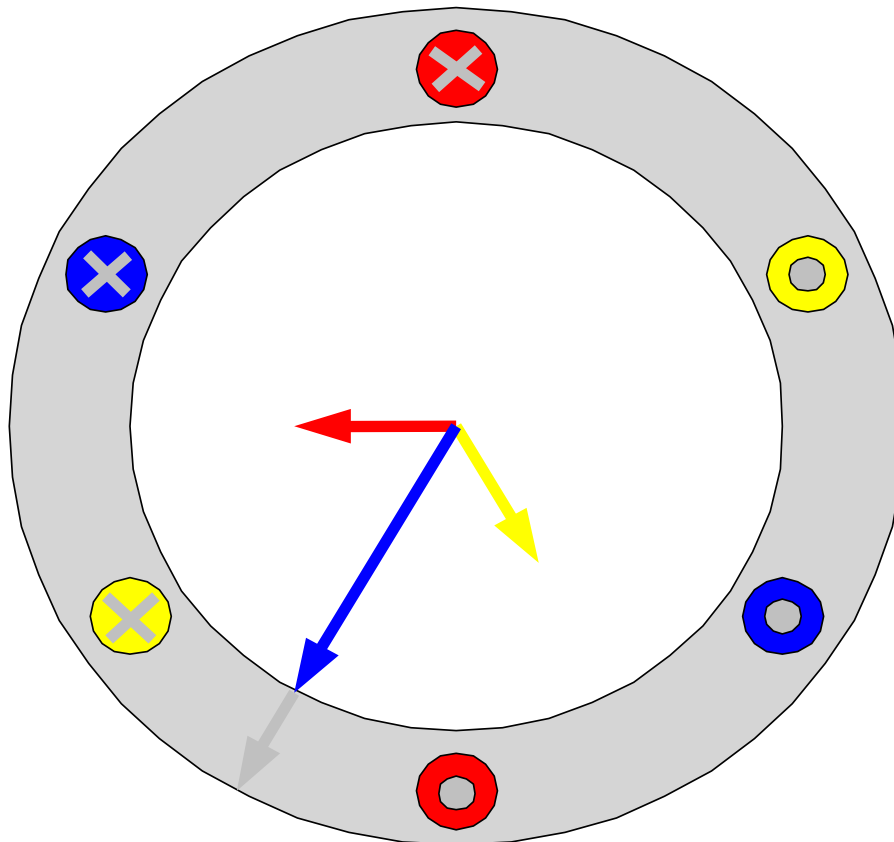

Time :  $t = 330 \text{ sec}$

Red phase = -50 V

Yellow Phase = -50 V

Blue Phase = +100 V

## Magnetic Field produced in a 2-pole induction motor (13/13)

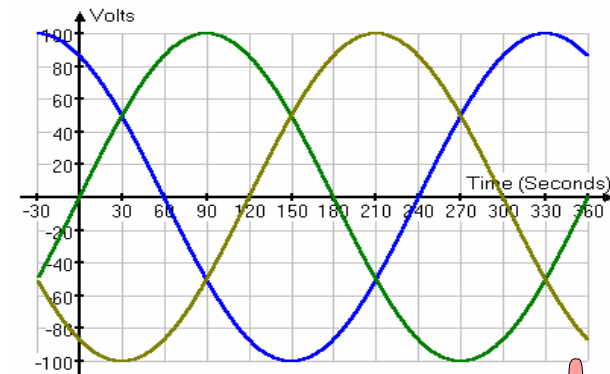
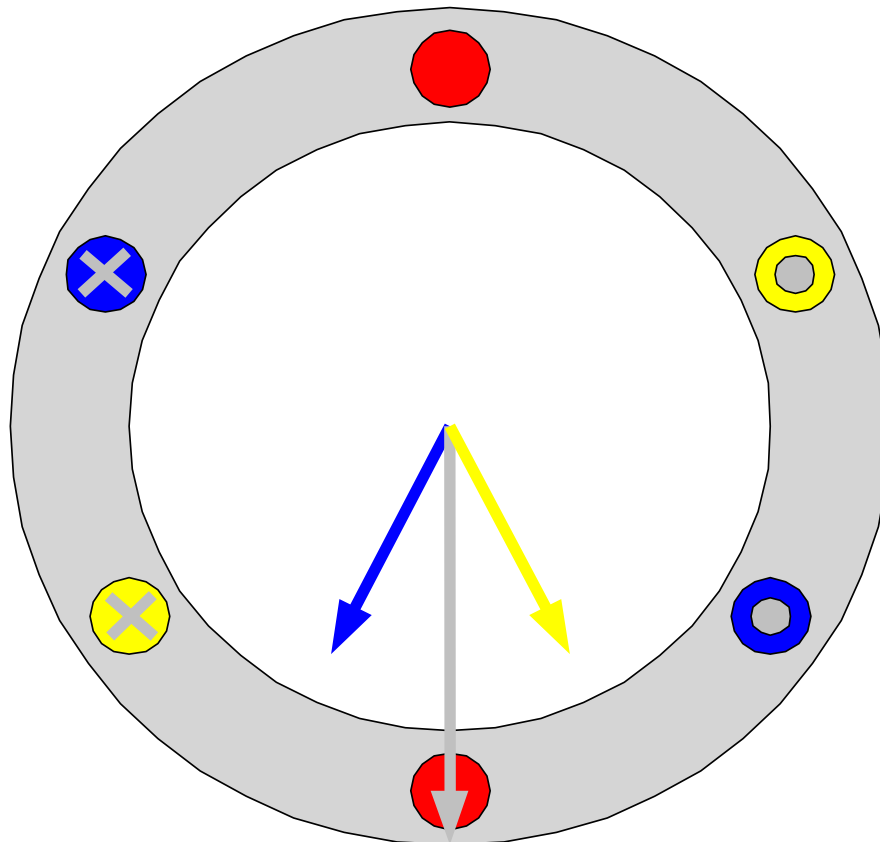

Time :  $t = 360 \text{ sec}$

Red phase = 0 V

Yellow Phase = -86.6 V

Blue Phase = +86.6 V

# 3-phase Induction Motor

## Constructions and Operating Principles

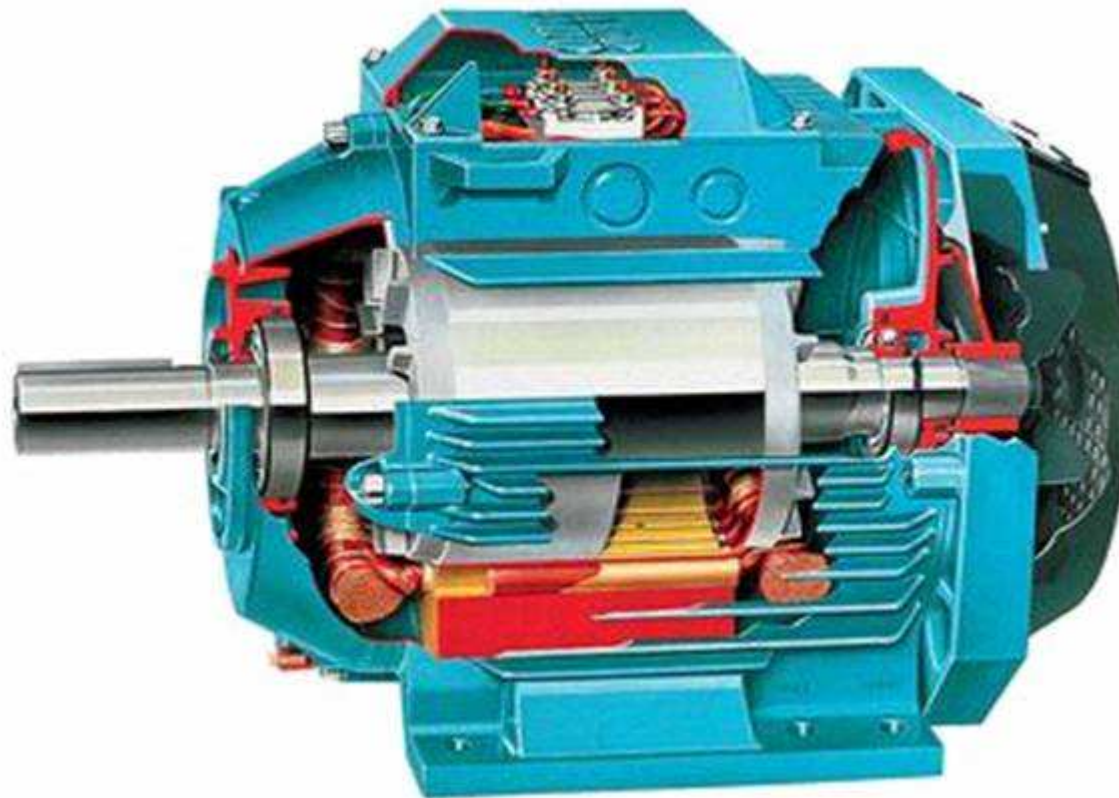

## Two types of 3- $\phi$ Induction Motor

1. Squirrel Cage Induction Motor
2. Slip-ring (wound) Rotor Induction Motor

### Stator Construction

Stator construction is the same for the two types of induction motors

Stator windings

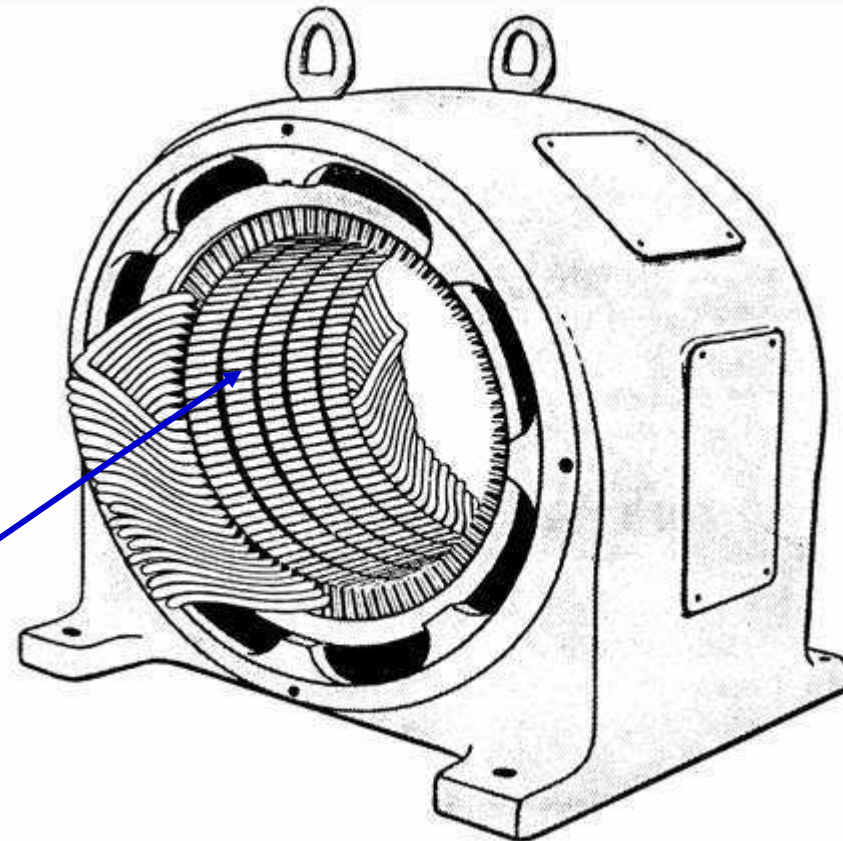

## Squirrel Cage Induction Motor (cross sectional view)

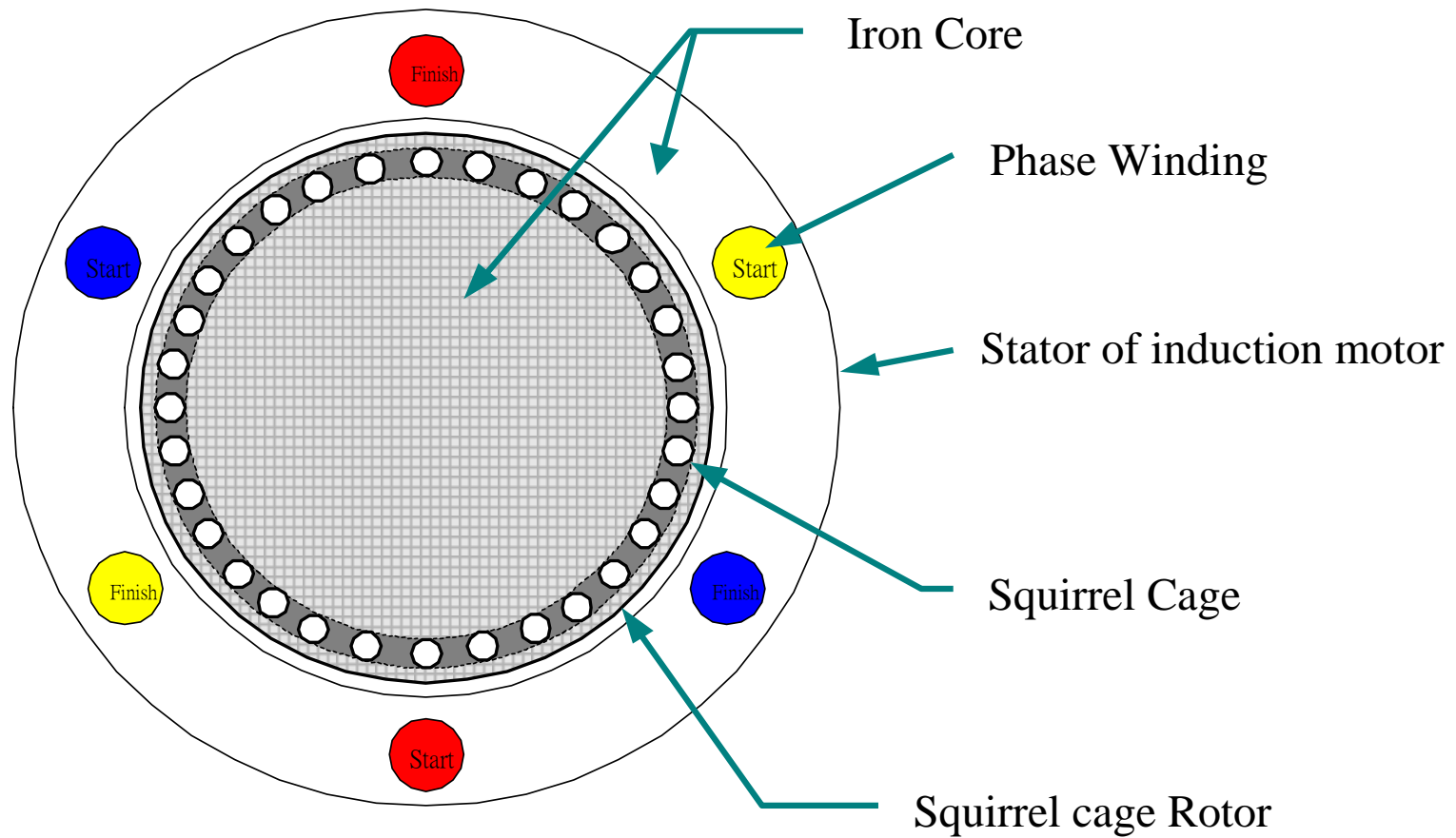

# Squirrel Cage Induction Motor

- its rotor is in form of Squirrel Cage

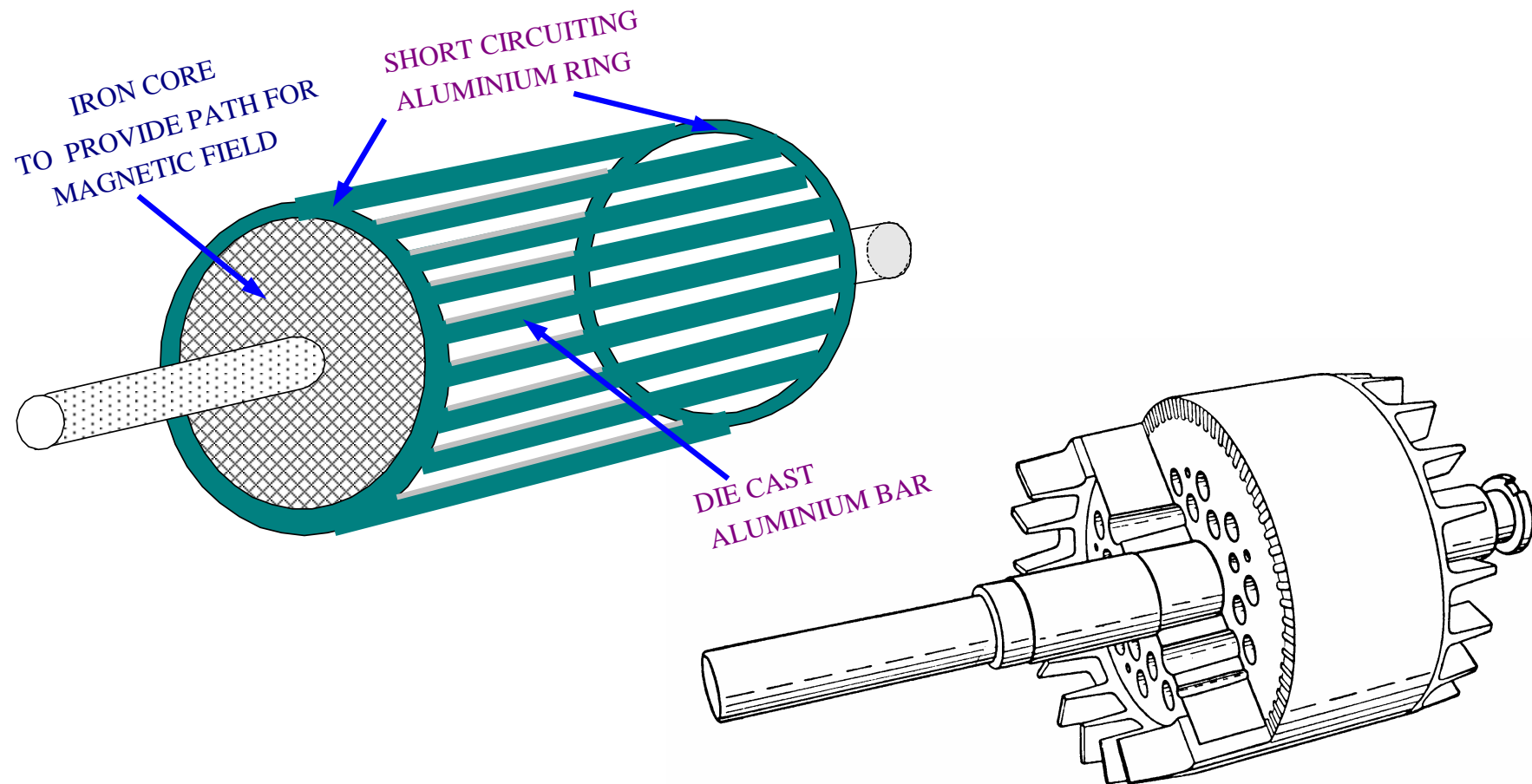

# Squirrel Cage Rotor

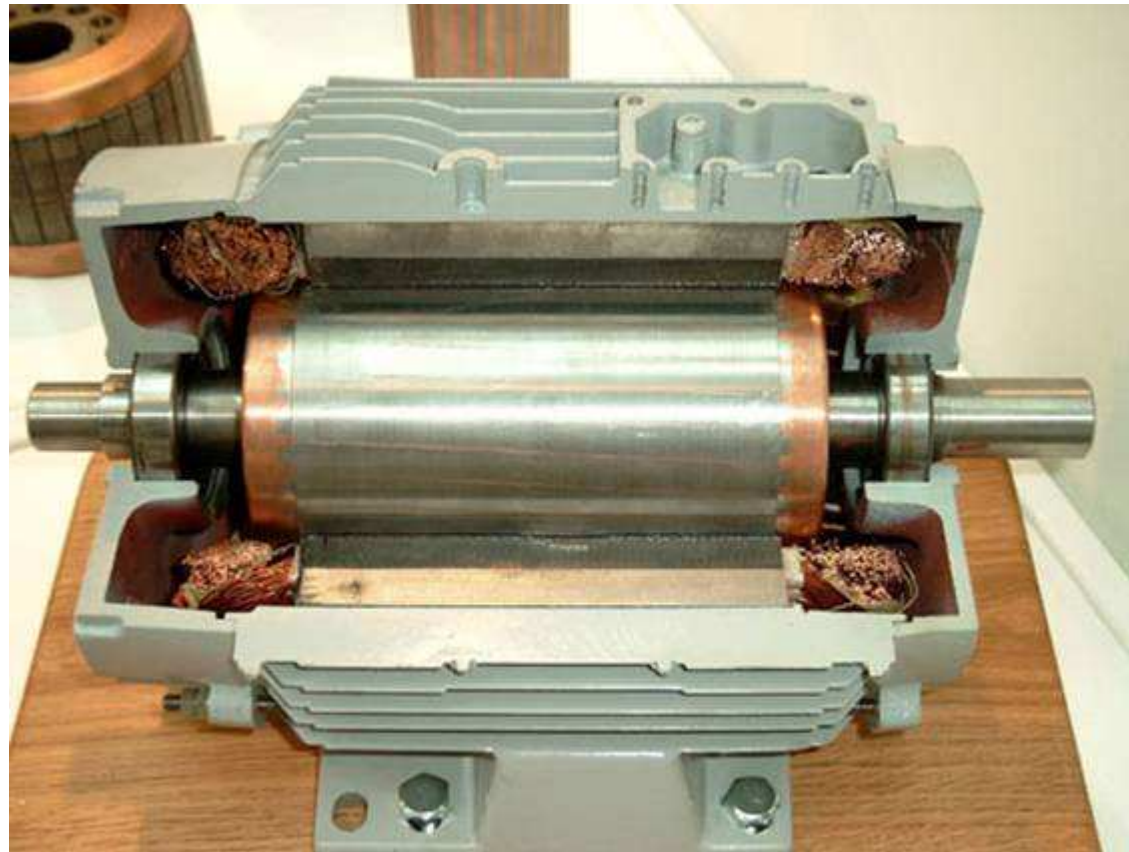

Die Cast Copper Rotor used in Energy-efficient Motors



## 3-phase Slip-ring (Wound rotor) Induction Motor

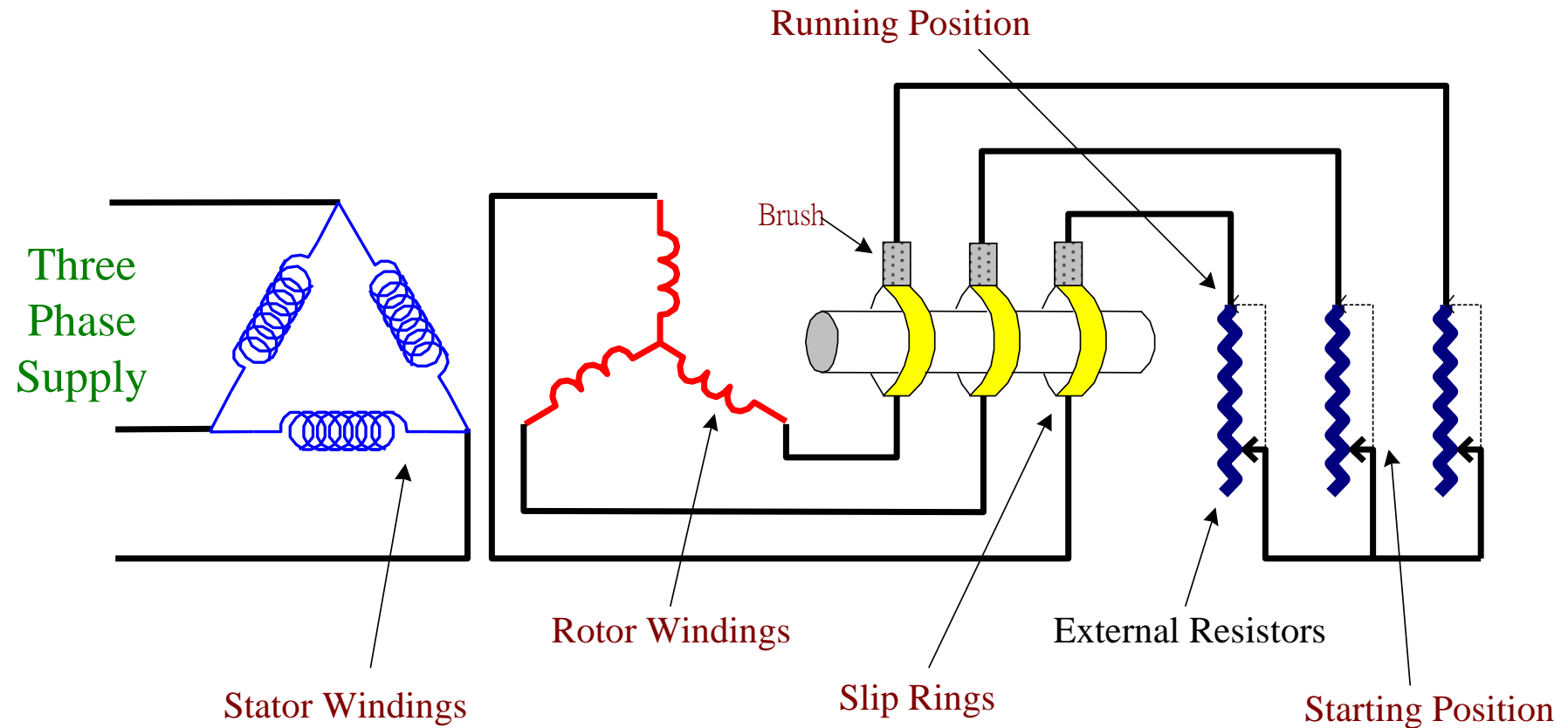

(Also called Wound Rotor Induction Motor)

## 3-phase Slip-ring (Wound rotor) Induction Motor

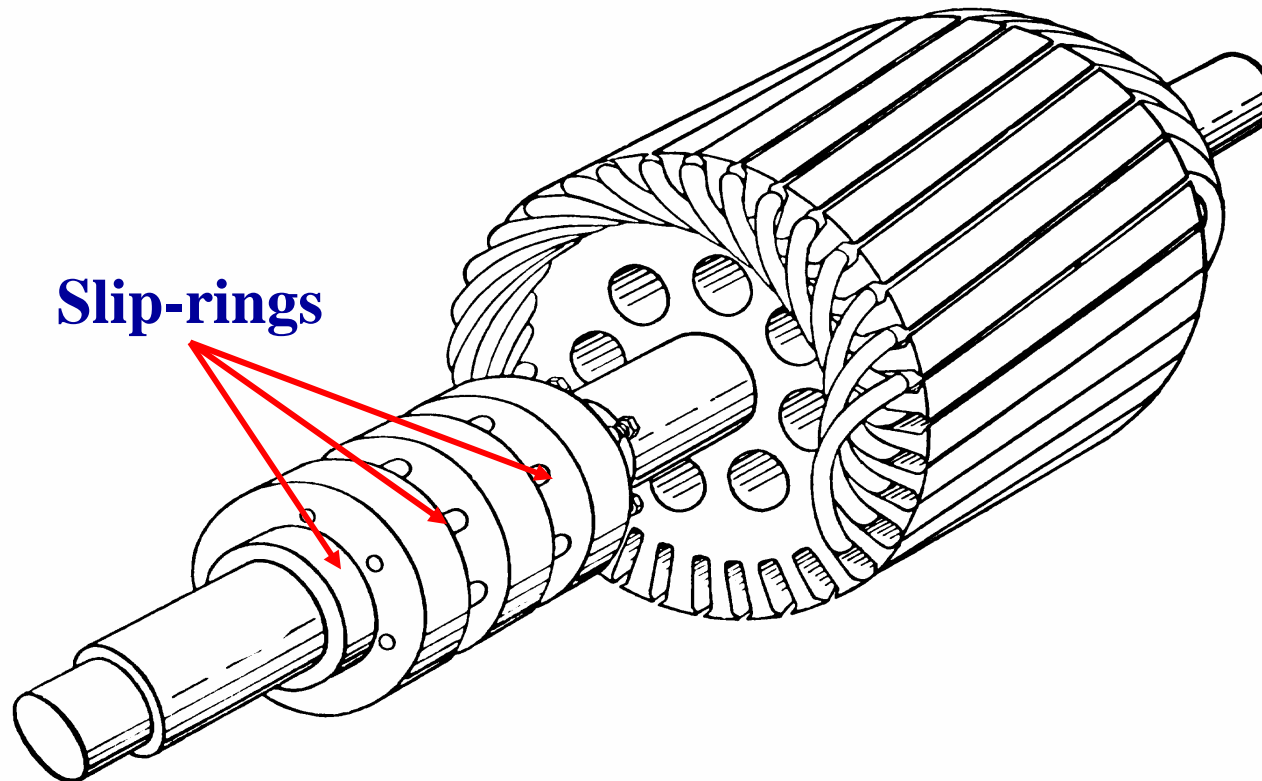

## 3-phase Slip-ring (Wound rotor) Induction Motor

- A slip ring rotor is wound with star connected three phase windings, the winding ends are brought out and connected to the exterior through ***three slip rings***.
- The cage rotor is easy to manufacture, hence it is cheap and robust. However, we cannot do anything with the rotor circuit, in other words we **cannot** control the speed or starting torque of a cage rotor.
- A slip ring rotor is expensive to manufacture and it is vulnerable to overheat, but we can ***connect suitable external resistance through the slip rings to the rotor circuit***. As a result, we **can** control the starting torque and running characteristic of the slip ring motor.

## Operating Principles of 3-phase induction motor

- A ***rotating magnetic field*** is produced when a three phase voltage is fed to the stator of a three phase induction motor
- This rotating field will traverse the aluminium conductors of the squirrel cage rotor
- According to ***Fleming's Right hand rule*** for generator, e.m.f. is induced in the aluminium bars of the squirrel cage
- According to ***Fleming's Left hand rule*** for motor, a torque is produced which will drive ***the rotor rotating in the same direction as the magnetic field***

- Rotor Conductor "cutting" by the Rotating Magnetic Field

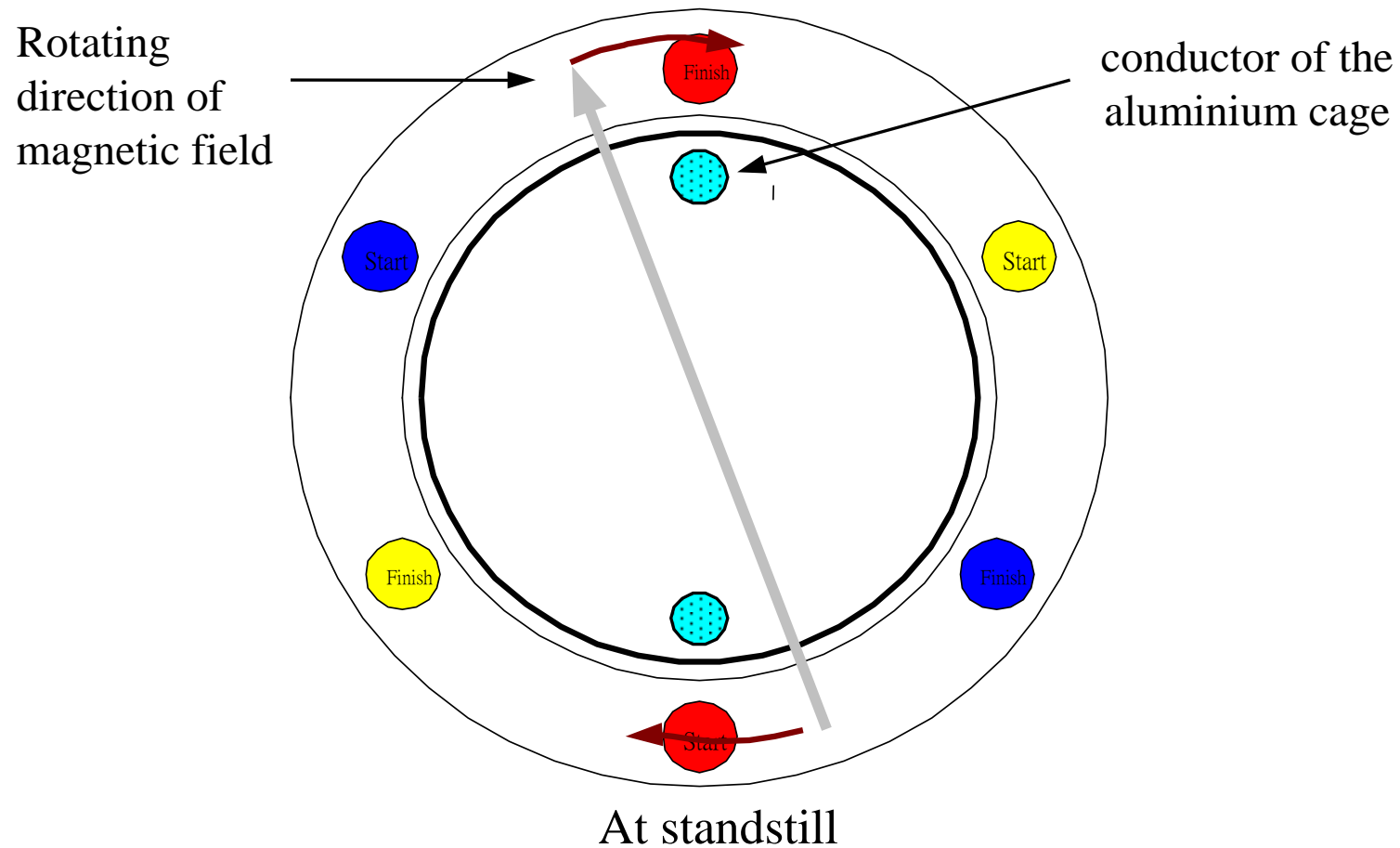

- Induced current is produced and flowing in the closed rotor conductor circuit
- The direction of the induced current is determined by Fleming Right Hand rule (Generation)

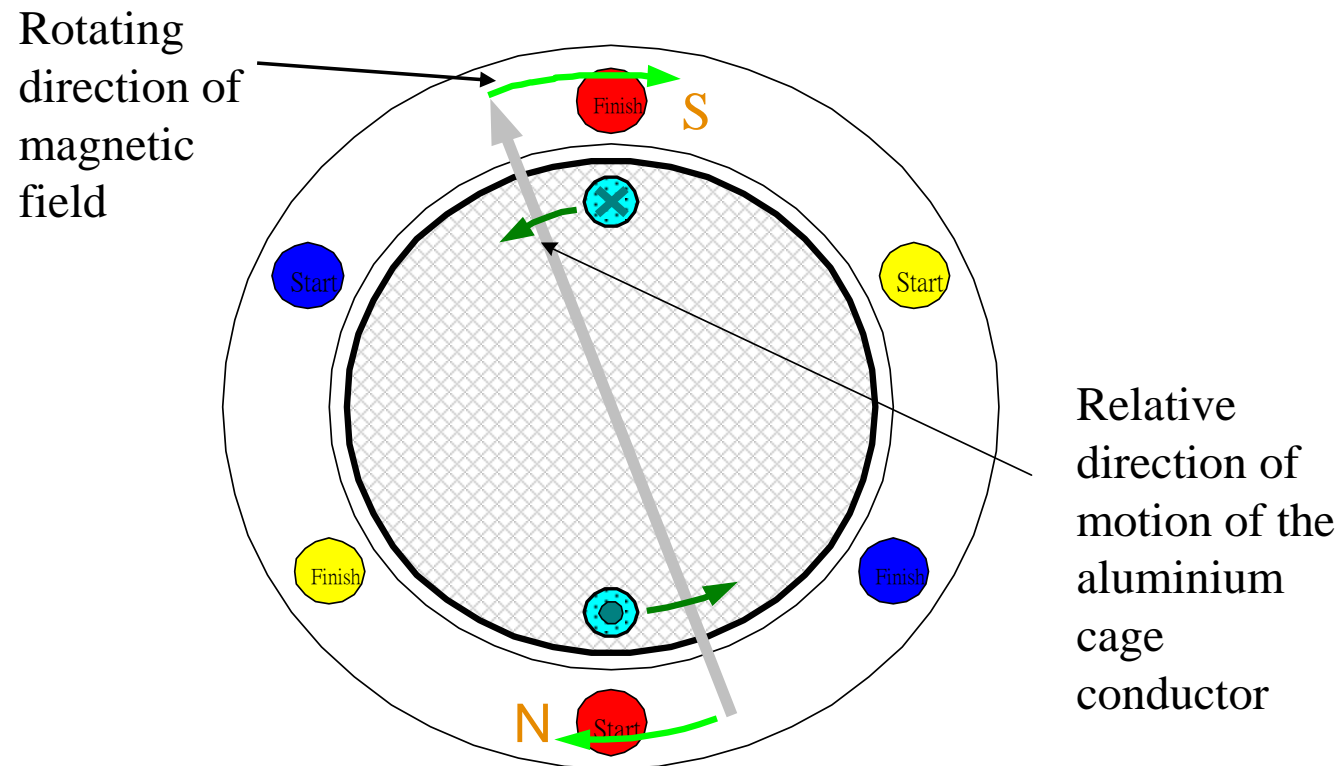

- An electromagnetic force is produced by the interaction between the induced current and the rotating magnetic field
- Thus an electromagnetic torque turns the rotor to rotate.
- The direction of the electromagnetic torque is determined by Fleming Left Hand rule (Motor)

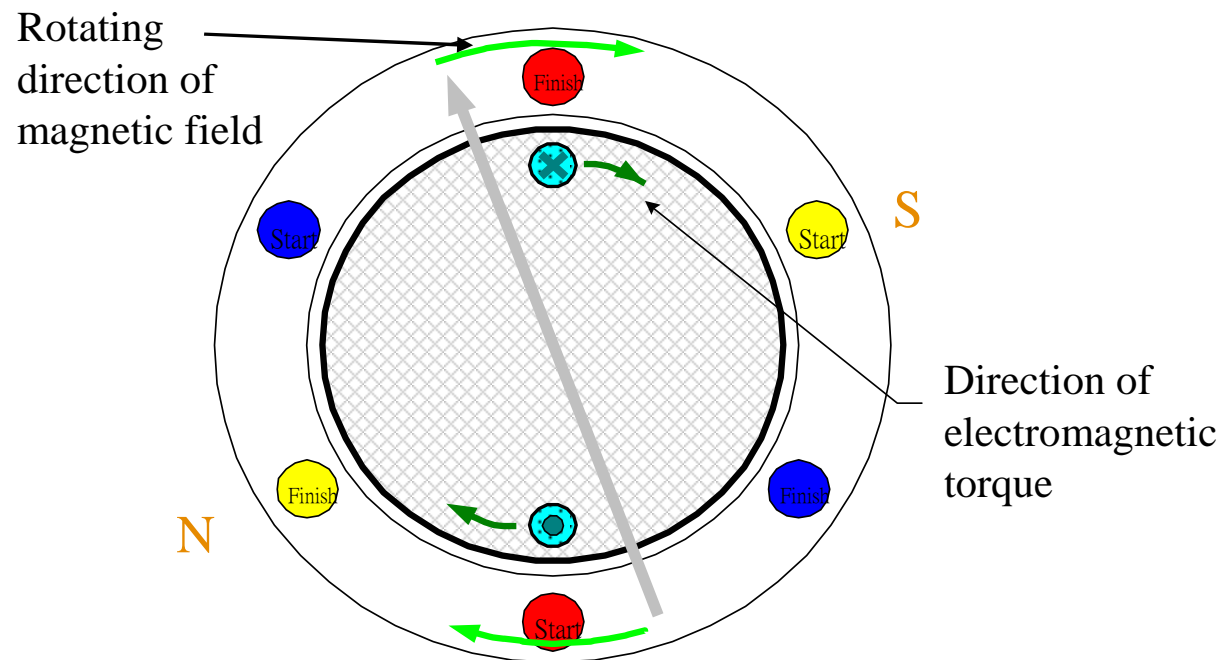

## Speed of Rotating Field

- ***Synchronous Speed*** [ $N_s$  (rpm) or  $n_s$  (rps)]
- We noticed that a complete sinusoidal cycle will cause the magnetic field produced to rotate a complete  $360^\circ$  in a two pole 3-phase induction motor.
- Since there are 60 seconds in one minute, the speed of the rotating field is equal to : *60 x frequency*
- A basic 2-pole induction motor has a set of three winding groups installed in the stator (**Red** start & finish, **Yellow** start & finish and **Blue** start & finish)



## Speed of Rotating Field

- For an induction motor with 4 poles, there are two sets of three winding groups installed in the stator, as a result, the magnetic field only rotates 180° for every complete cycle of the sinusoidal waveform. Therefore, for an induction motor with  $p$  pole-pairs, the speed of the rotating field is given by:

$$\frac{f}{p} \text{ (rps)} \quad OR \quad \frac{60f}{p} \text{ (rpm)}$$

$f$  = supply frequency and  $p$  = No. of pole-pairs

## Slip

- The magnetic field of an induction motor rotates at a **synchronous speed ( $N_s$ )** which is equal to  $\frac{60f}{p}$
- This magnetic field will induce current in the rotor circuit, causing the rotor to run in the same direction as the field
- However, the **speed of the rotor ( $N_r$ )** is always slower than the speed of the field. Since if the speed of the rotor is equal to that of the field there will be no induced e.m.f. and there will be no driving torque to keep the rotor running
- Slip ( $s$ ) is defined as  $\frac{N_s - N_r}{N_s}$

## Example of Slip Calculation

Calculate the slip of an 8-pole, 3-phase induction motor running at 846 rpm. The frequency of the three phase supply is 60 Hz.

$$\text{Synchronous speed } N_s = \frac{60 \times \text{frequency}}{\text{pole} - \text{pairs}} = \frac{60 \times 60}{4} = \mathbf{900 \text{ rpm}}$$

$$\text{Rotor speed } N_r = 846 \text{ rpm}$$

$$\begin{aligned} \text{Therefore Slip} &= \frac{N_s - N_r}{N_s} = \frac{900 - 846}{900} = \frac{54}{900} \\ &= \mathbf{0.06} \end{aligned}$$

## Slip Equation Revisit

$$s = \frac{N_s - N_r}{N_s}$$

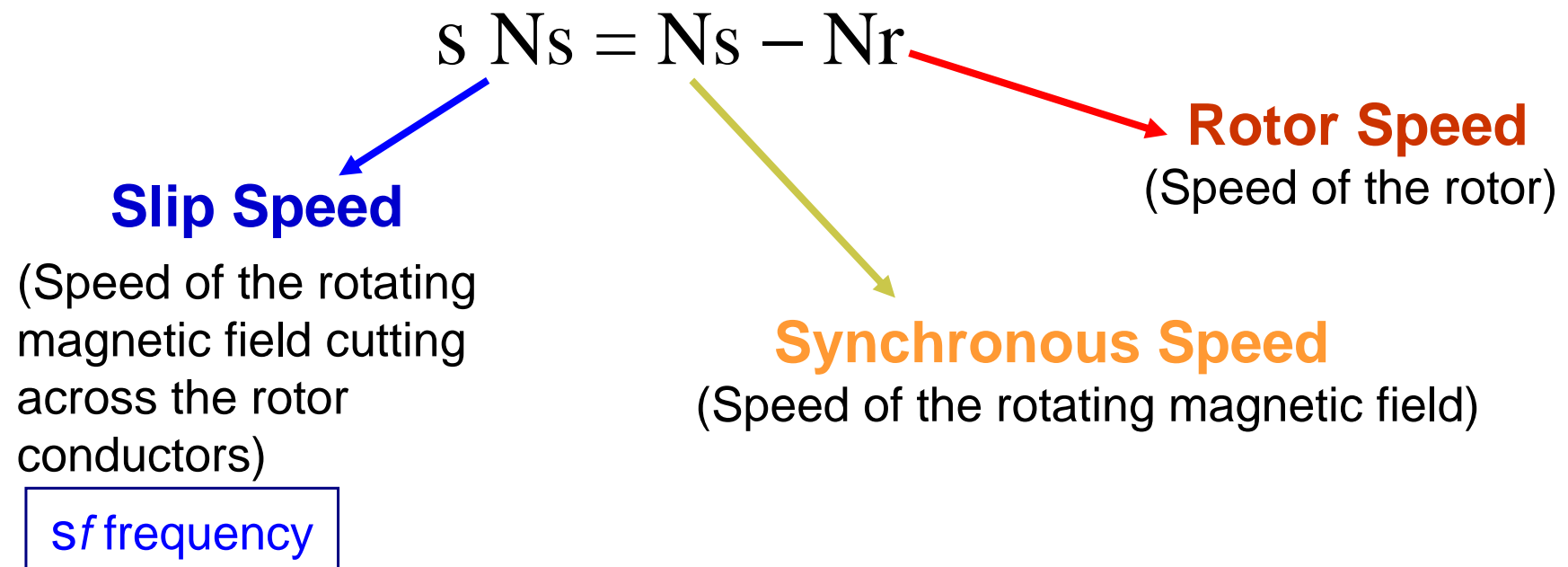

# Typical Torque / Slip Curve of Induction Motor

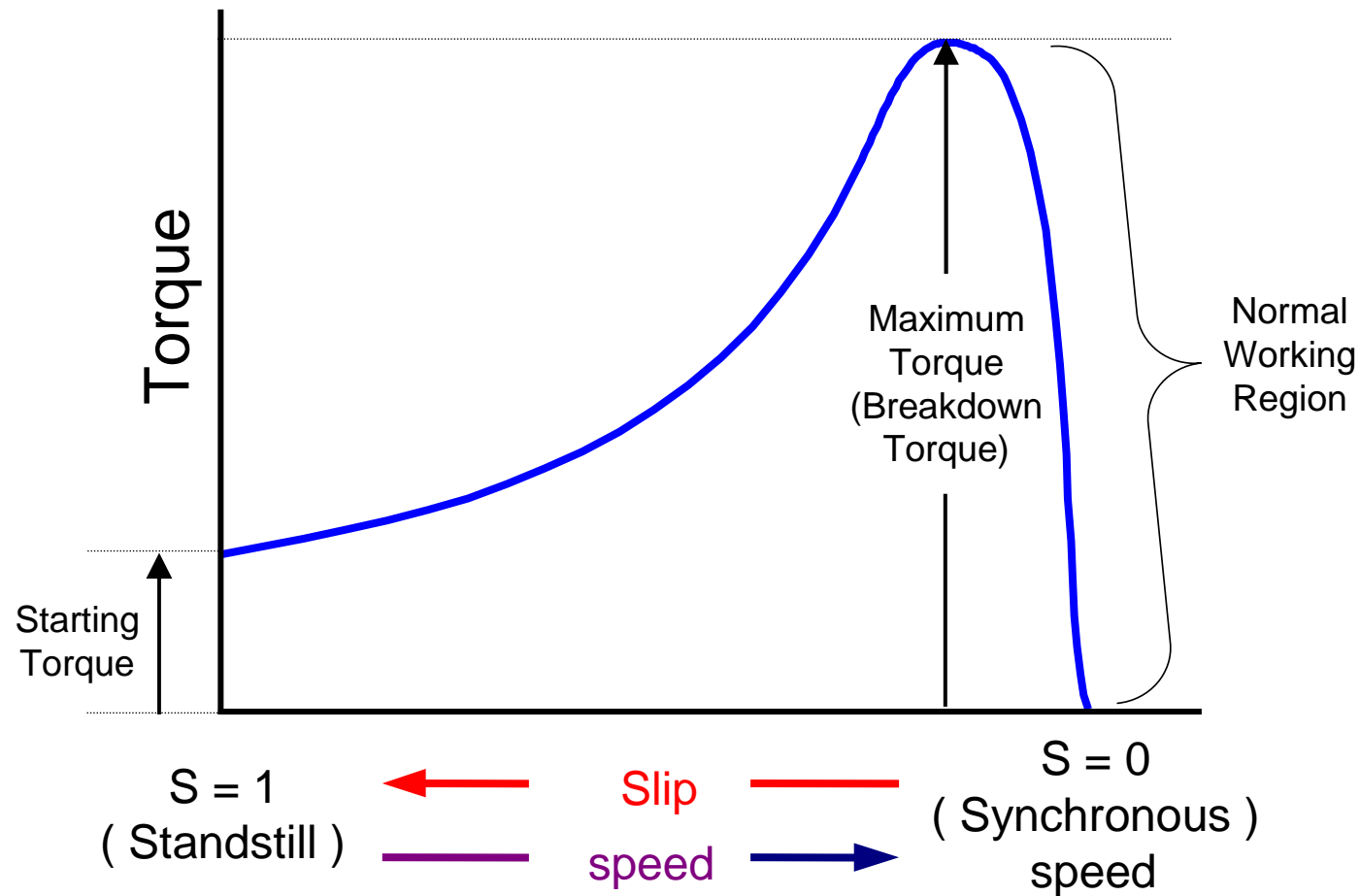

## Starting Method of Induction Motors

A squirrel cage motor is at stationary before it is started, there is no back e.m.f. to oppose the current. Therefore, if this motor is connected directly to the supply, will take an initial starting current which is about 5 to 6 times of the full load value.

Though this current decreases rapidly as the motor accelerates, it will cause harm to the motor and will affect the voltage regulation of the power supply

### 1. Direct on Line (DOL)

Small motors up to the size of 5 hp are allowed to be started with direct on line (DOL) starter

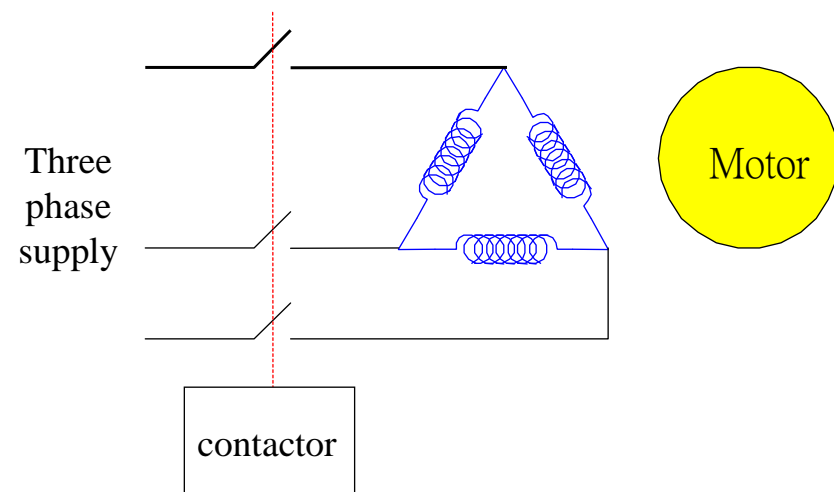

## 2. Star-Delta Starter

- When the rating of the motor exceed 5 hp Some starting means must be used to start the motor. A star/delta starter is normally used because it is the simplest and cheapest type of starter.
- During starting, the stator winding is temporarily connected in star, therefore only phase voltage is applied to the stator. The starting current is reduced to  $\frac{1}{3}$  of the Direct on line starting current. The starting torque, which is proportional to the starting current, reduces also to  $\frac{1}{3}$  of the value at direct on line starting.
- After a period of about 5 seconds, the motor have accelerated to nearly full load speed. The stator winding is now reconnected as delta, and full line voltage is applied each phase of the stator.

# Schematic Diagram of a Star-Delta Starter

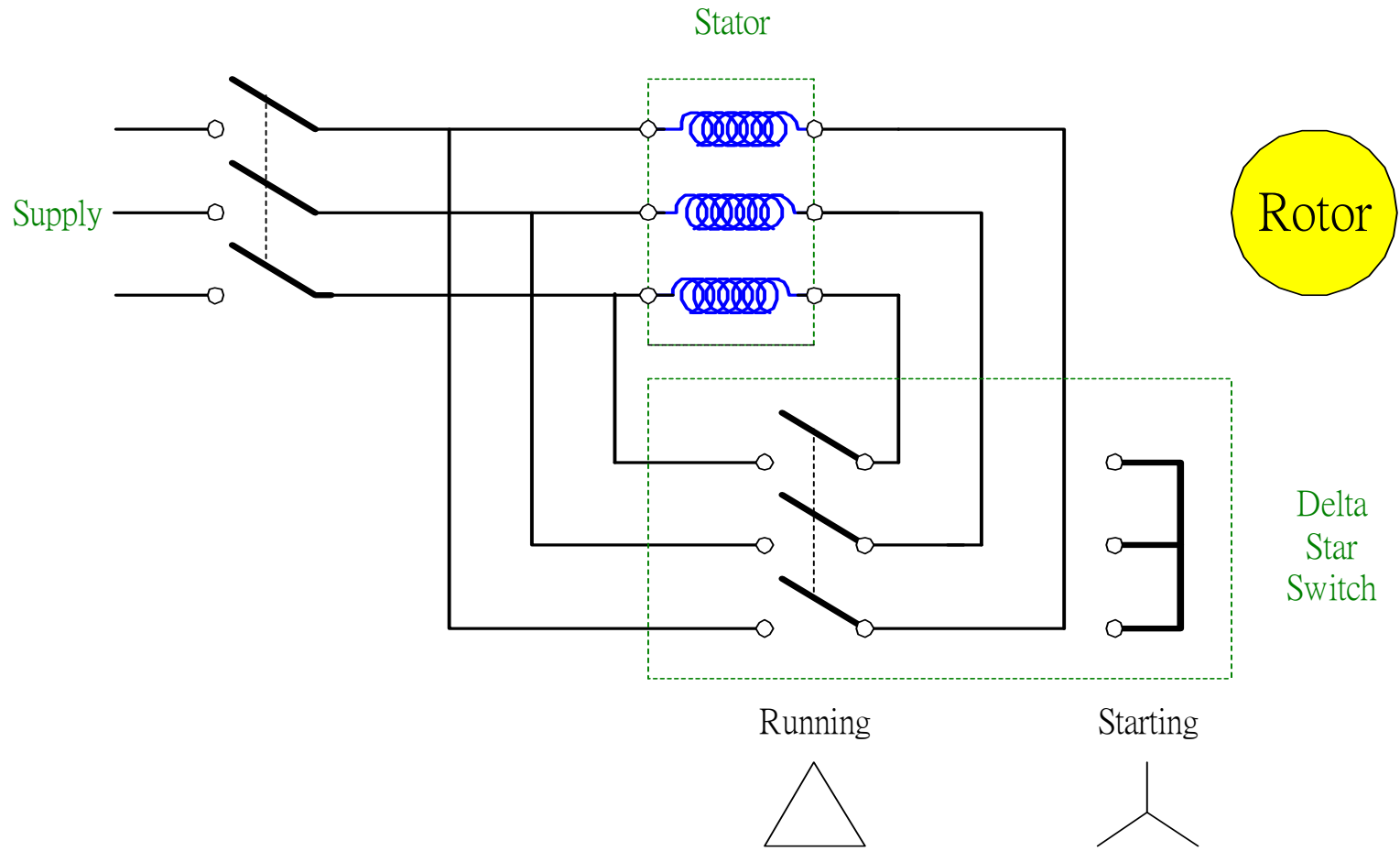



### 3. Auto-transformer Starter

- Some loads are very heavy and it will take a few minutes before it can run to full speed, these motors have to be started by means of transformer starter.
- The reduced voltage during starting is obtained from the different tapplings (40% , 60% , 75%) of an auto-transformer.
- In the running condition, full voltage is applied to the stator and the transformer is cut out of the circuit.

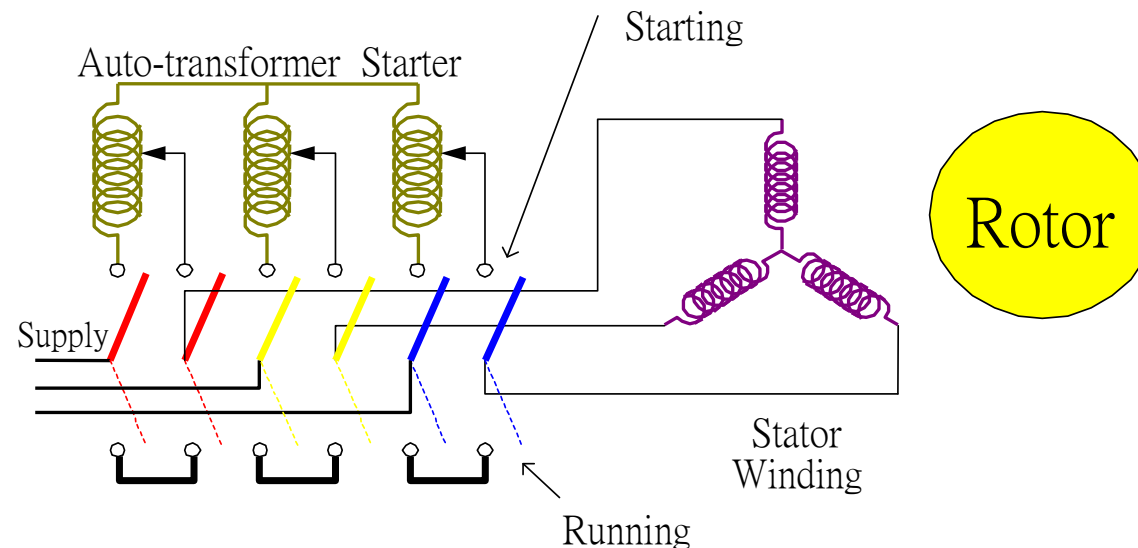

## 4. Starting of Wound Rotor Induction Motor

- The wound rotor (slip ring) induction motor can be started by inserting additional resistance in series with the rotor winding through the slip rings.
- In this way, maximum torque is obtained during starting. The additional resistance is cut off from the circuit as soon as the motor is started to avoid excessive power loss in the resistance.

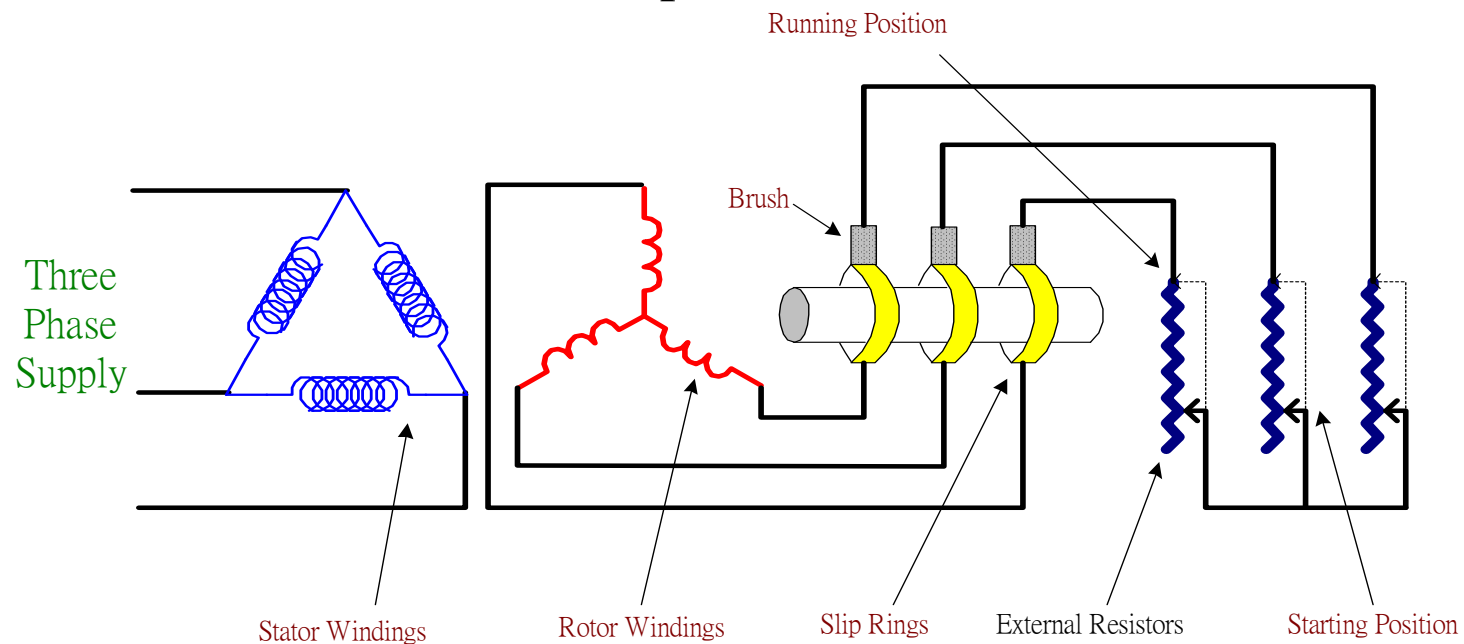

# Synchronous machines

## Basic construction

- A 3-phase synchronous machine is essentially composed of a stationary stator and a rotating rotor
- The stator is made of soft iron to provide the magnetic field a path with low permeability, the iron is laminated to reduce eddy current and hysteresis iron loss. The stator had a similar construction as that of a 3-phase induction motor. Three phase windings installed in the stator slots which are placed at 120 electrical degree apart
- The rotor is an electromagnet placed inside the stator, the rotor has the same number of poles as that of the stator. There are two types of rotor construction; the salient pole and the cylindrical rotor.

## Three phase synchronous generator

- The salient pole generator has a salient pole rotor structure, this machine is ideal for slow running power generation at 50 - 60 Hz. The salient pole is wound with D.C. winding and current is fed to the rotor via slip rings. The salient pole has a nearly sinusoidal air gap so that the machine will produce sinusoidal output.
- The cylindrical rotor generator has a cylindrical rotor, the rotor is wound with windings fed with D.C. currents. The number of windings in each slot is so selected that the magnetic flux is close to sinusoidal distribution. However, the output waveform is still polygonal in shape and there is a high harmonic contents in the generated voltage.

# Salient pole three phase synchronous generator

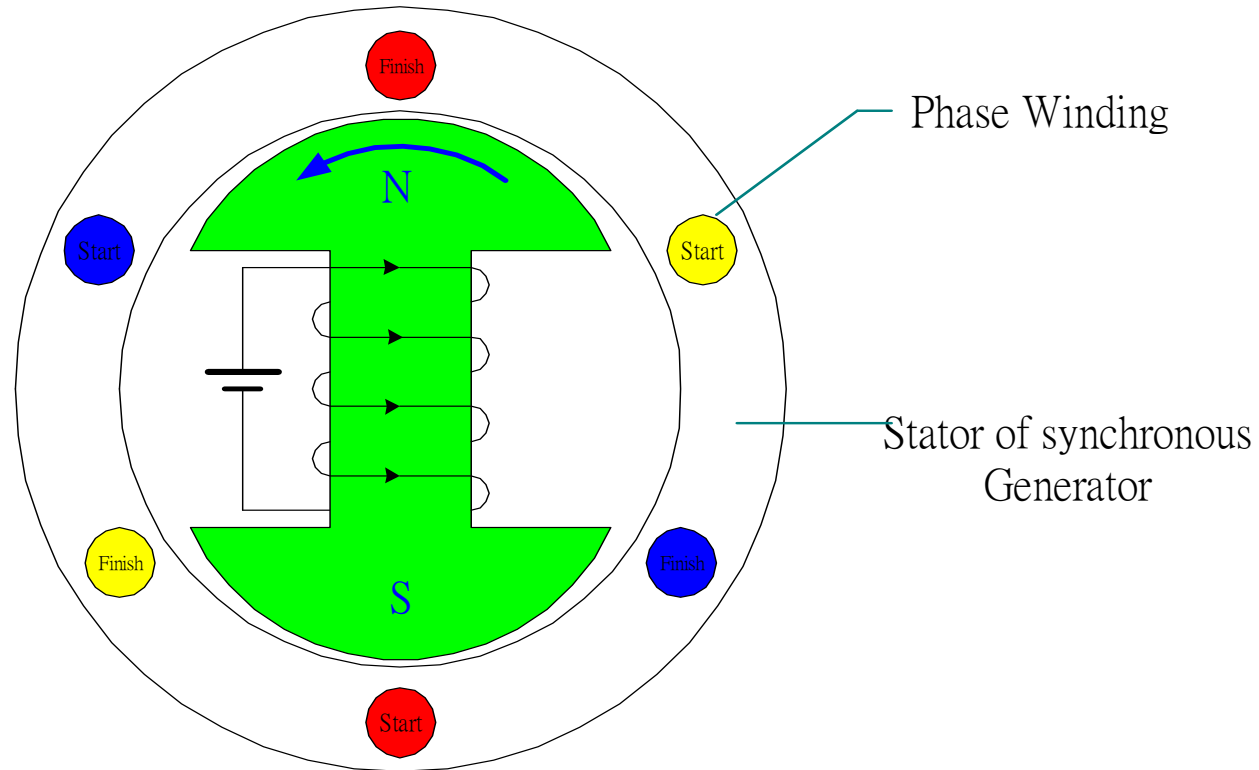

## Salient pole synchronous generator

- **Advantages:**

- The air gap between the stator and the rotor can be adjusted so that the magnetic flux is sinusoidal in distribution. As a result the output waveform will also be sinusoidal in nature

- **Disadvantages:**

- The salient pole has a weak structure so that this machine is not suitable for high speed application such as the turbo-generator on air-plane.
- The salient pole generator is expensive

## Cylindrical rotor synchronous generator

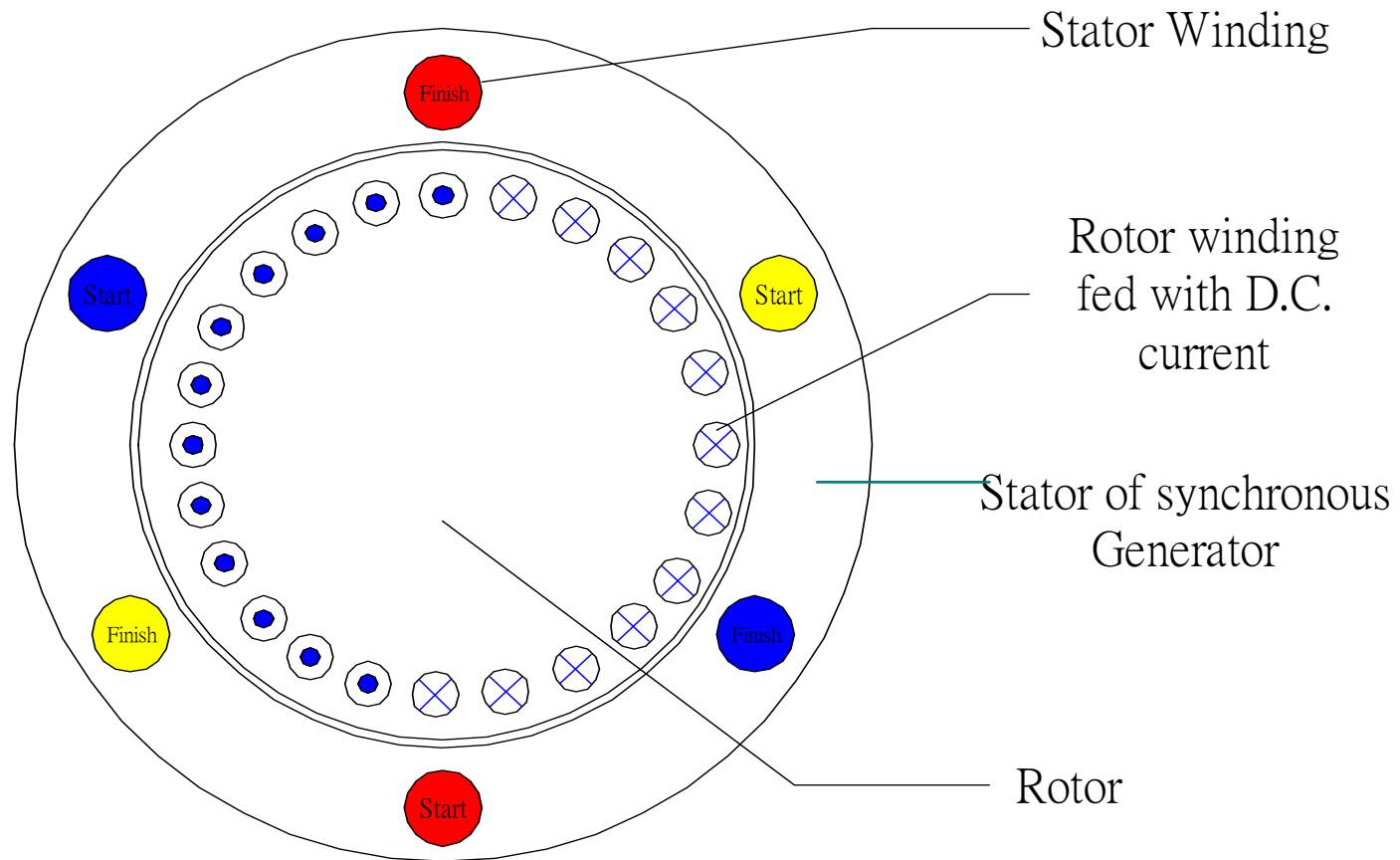

## Cylindrical rotor synchronous generator

- **Advantages:**

- The cylindrical rotor is cheaper than the salient pole rotor
- The cylindrical rotor is robotic in design, because it is symmetrical in shape, dynamically balance can be easily obtained. Hence it can be used for high speed application, say, coupled to turbo-engine such as the generator in an air-craft.

- **Disadvantages:**

- The air gap is uniform for the rotor, the generated voltage will have a polygonal waveform depending on the number of windings on each of the rotor slots. Though the shape of the polygon is adjusted to be nearly sinusoidal, the output waveform still defers from the sine wave and therefore the harmonic content of the cylindrical rotor generator is high compared with that of the salient pole design



## Reasons for need of synchronous generator

- Dual voltages can be obtained from three phase supply; for example, 380 V three phase line voltage for heavy power applications and 220 V single phase voltage for domestic and light current applications.
- It is more economic to use three phase power. Only three conductors are required to transmit three-phase currents for balanced three-phase load compared with six conductors for three single phase loads.
- A rotating magnetic field will be produced when three phase currents are fed to the stator of a 3-phase induction motor, thus providing cheap and convenient mechanical power for industry
- The synchronous generator can generate leading power factor kVA which can compensate the lagging power factor of the power transmission system

# Fleming's Right Hand Rule for generator

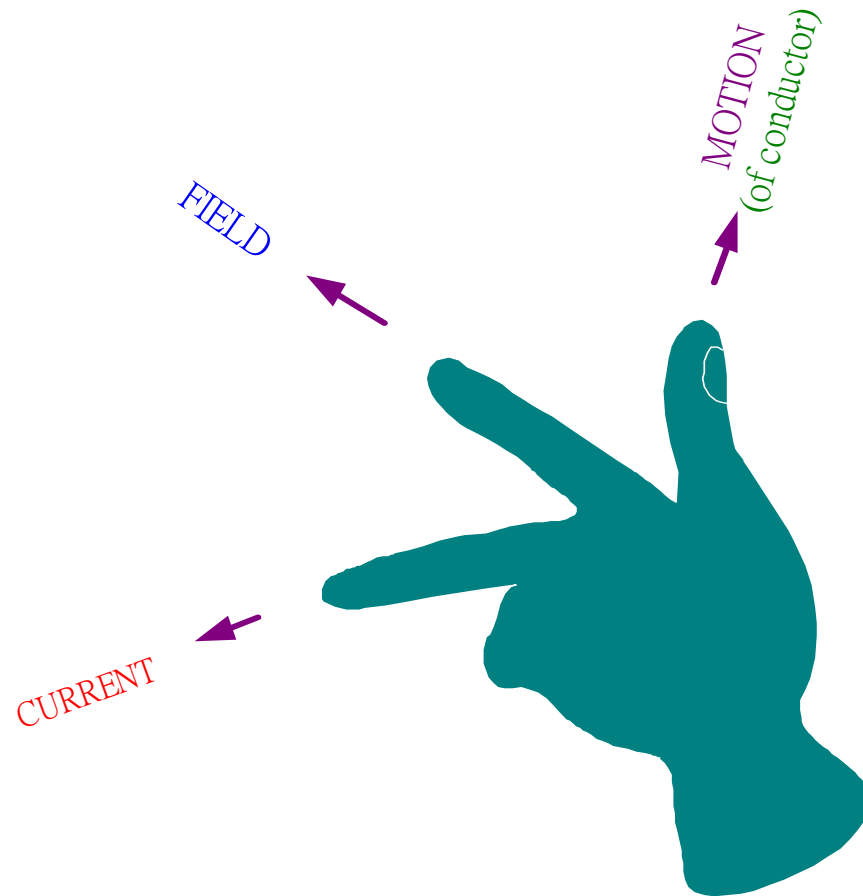

# Three phase voltages produced by the salient pole generator

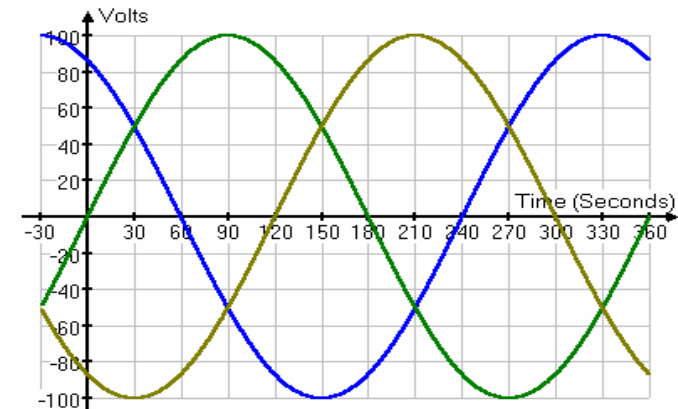
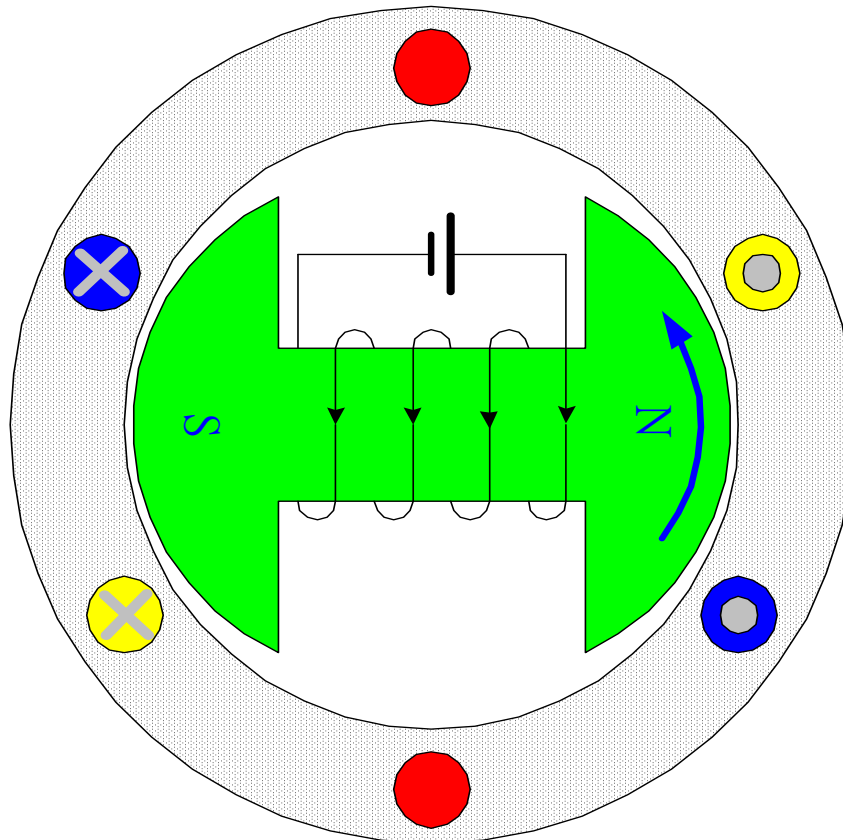

Time :  $t = 0$

- Red phase = 0 V
- Yellow Phase = -86.6 V
- Blue Phase = +86.6 V

# Three phase voltages produced by the salient pole generator

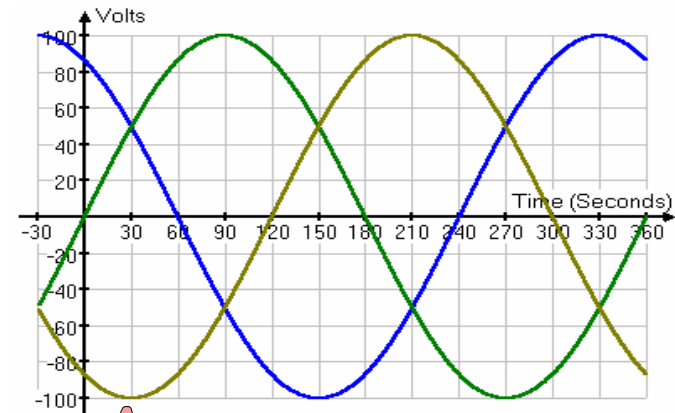
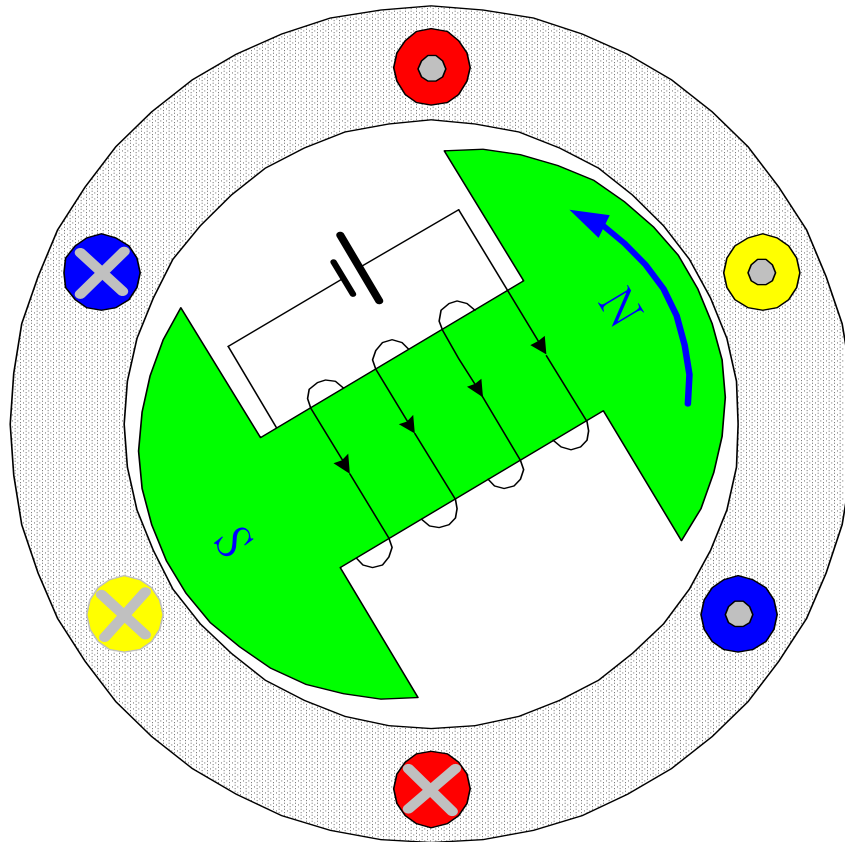

Time :  $t = 30 \text{ Sec}$

- Red phase = 50 V
- Yellow Phase = - 100 V
- Blue Phase = + 50 V

# Three phase voltages produced by the salient pole generator

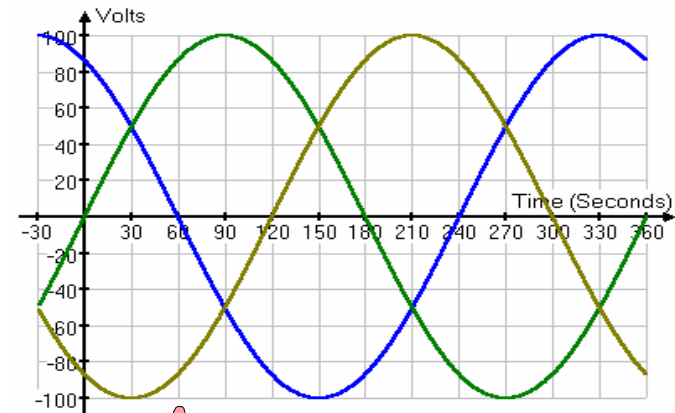
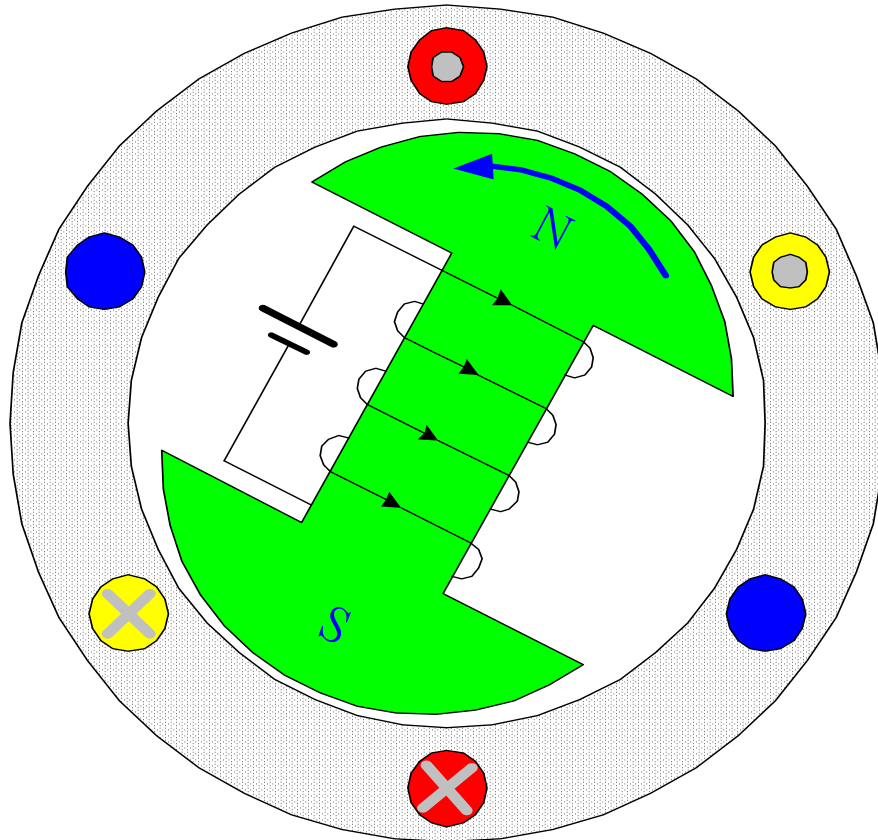

Time :  $t = 60 \text{ sec}$

- Red phase = +86.6 V
- Yellow Phase = -86.6 V
- Blue Phase = 0 V

# Three phase voltages produced by the salient pole generator

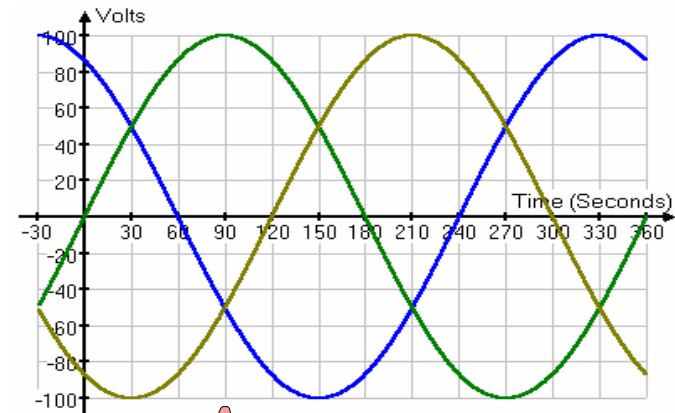
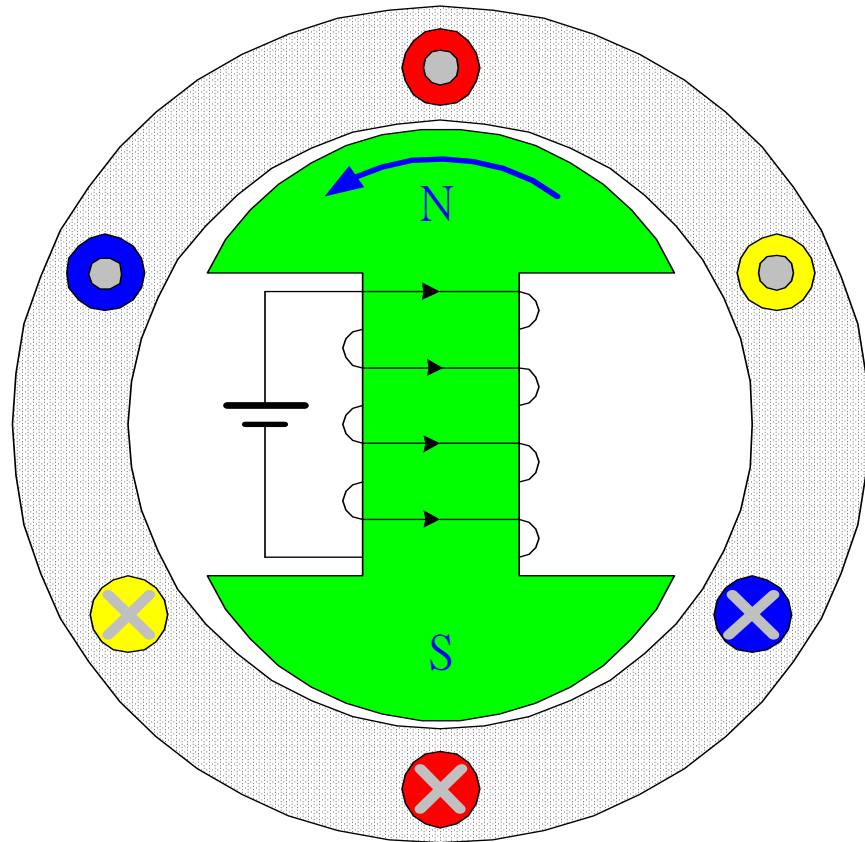

Time :  $t = 90 \text{ sec}$

- Red phase = +100 V
- Yellow Phase = - 50 V
- Blue Phase = - 50 V

# Three phase voltages produced by the salient pole generator

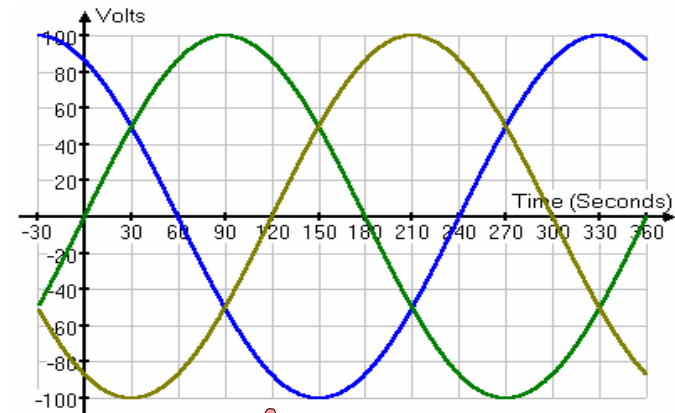
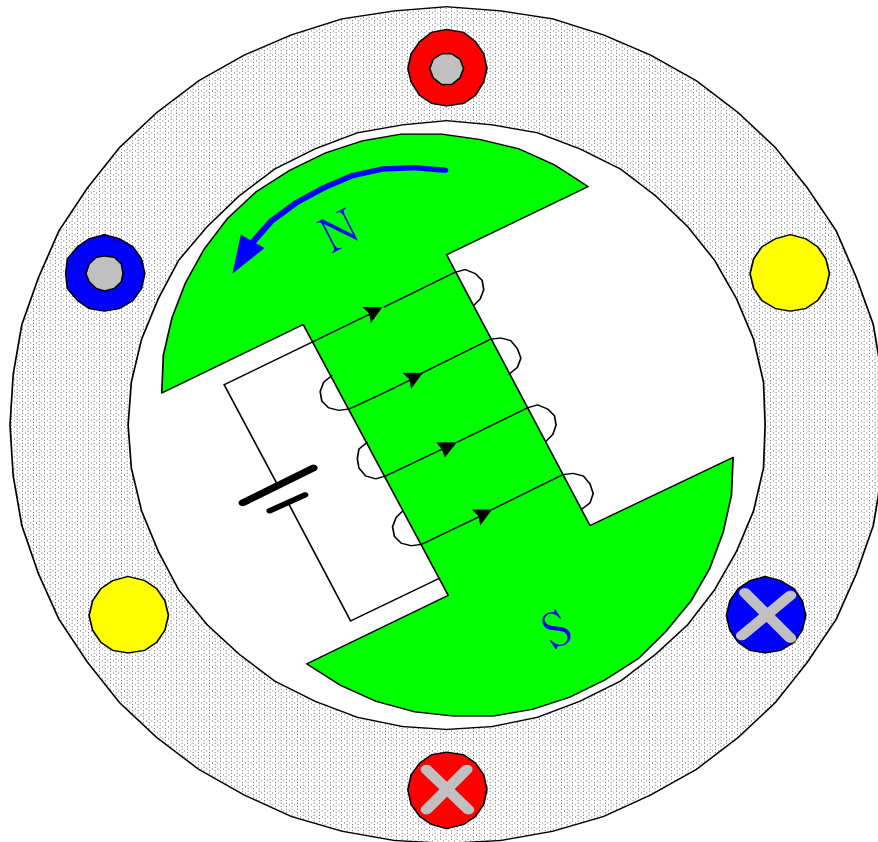

Time :  $t = 120 \text{ sec}$

- Red phase = +86.6 V
- Yellow Phase = 0 V
- Blue Phase = -86.6 V

# Three phase voltages produced by the salient pole generator

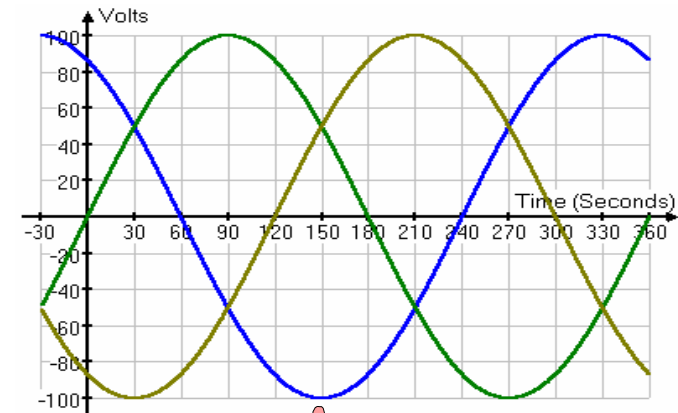
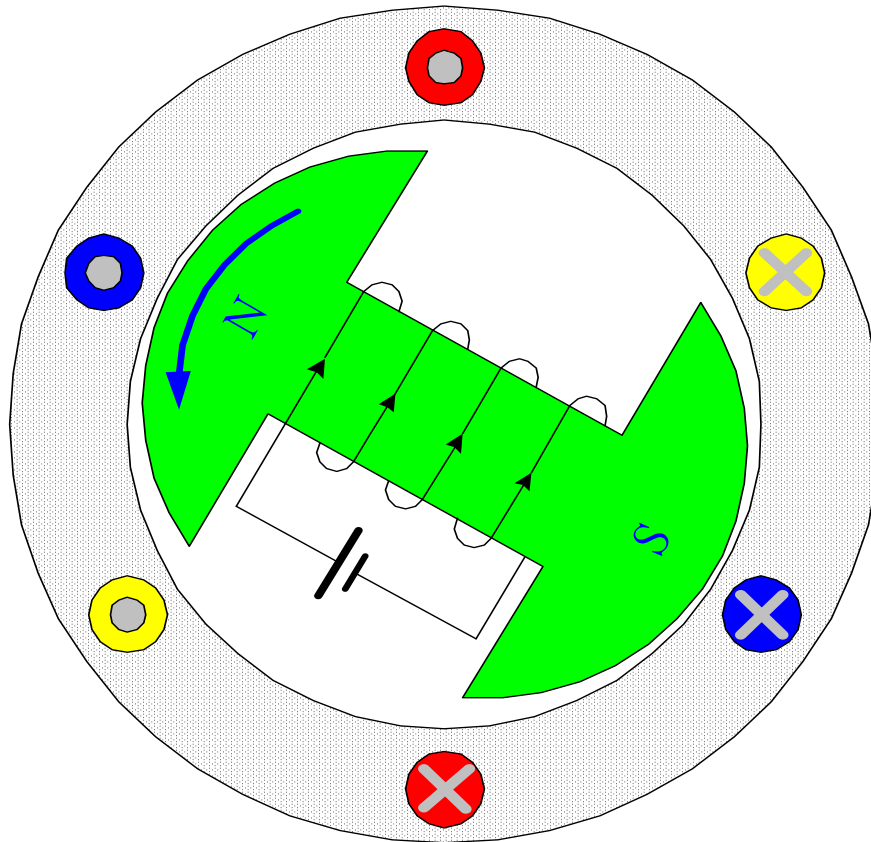

Time :  $t = 150 \text{ sec}$

- Red phase = +50 V
- Yellow Phase = +50 V
- Blue Phase = -100 V



# Three phase voltages produced by the salient pole generator

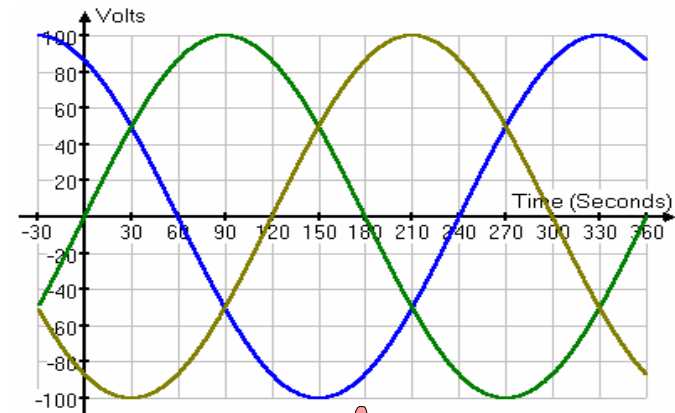
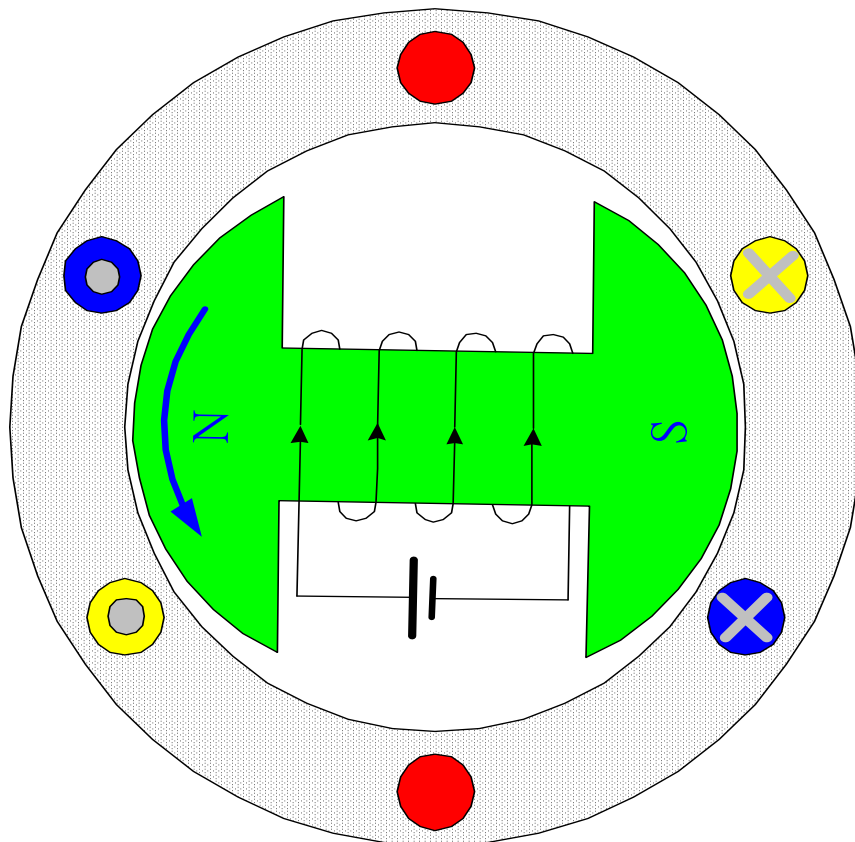

Time :  $t = 180 \text{ sec}$

- Red phase = 0 V
- Yellow Phase = +86.6 V
- Blue Phase = -86.6 V

# Three phase voltages produced by the salient pole generator

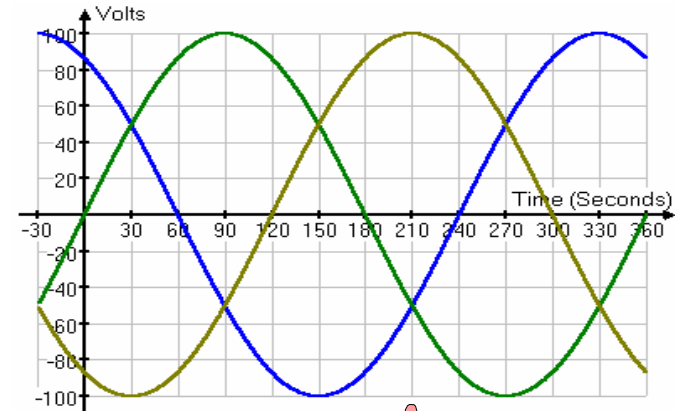
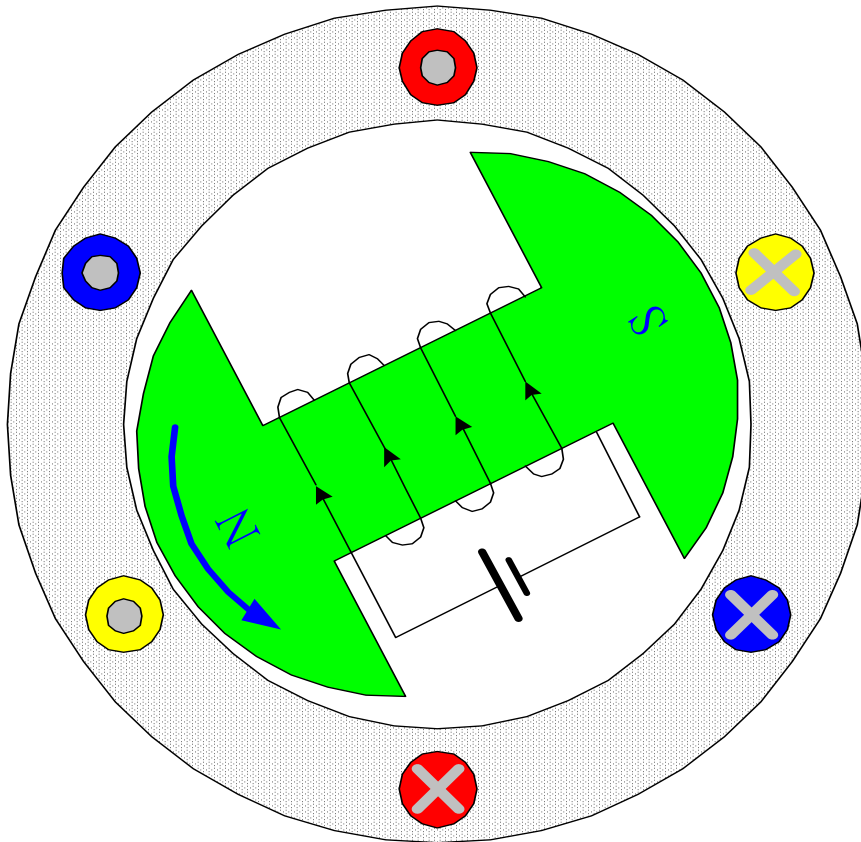

Time :  $t = 210 \text{ sec}$

- Red phase = -50 V
- Yellow Phase = +100 V
- Blue Phase = -50 V

# Three phase voltages produced by the salient pole generator

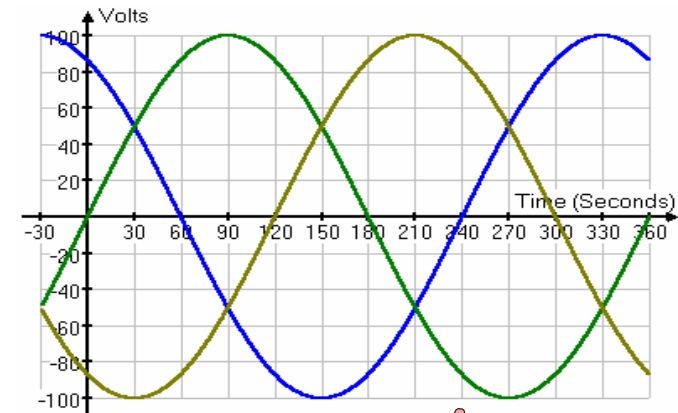
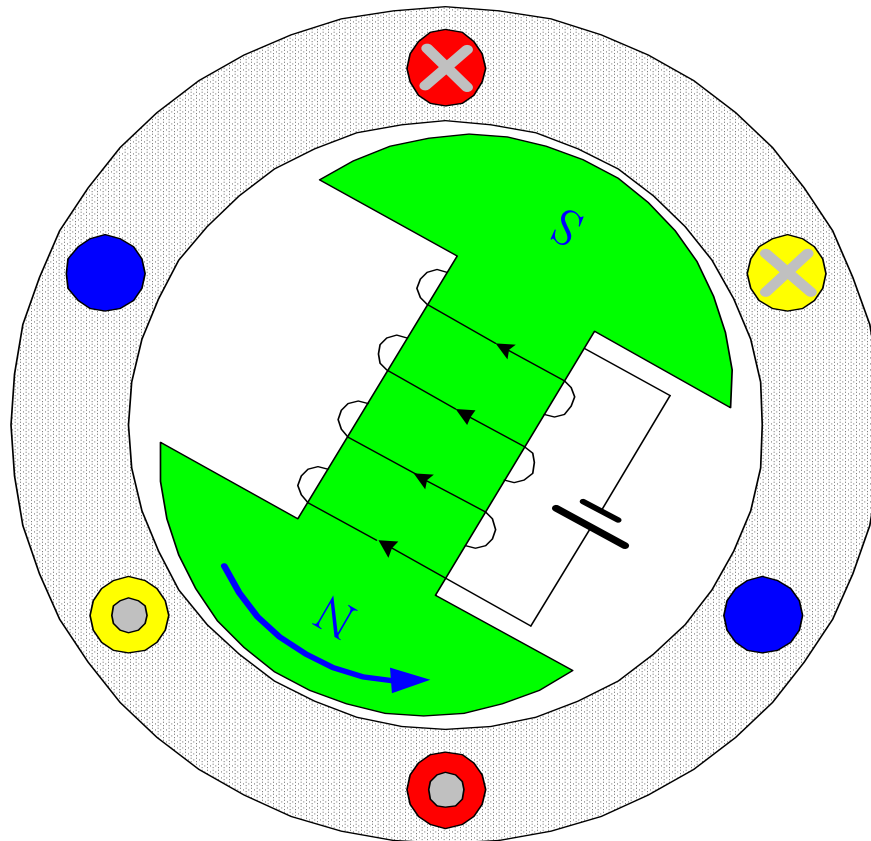

Time :  $t = 240 \text{ sec}$

- Red phase = -86.6 V
- Yellow Phase = +86.6 V
- Blue Phase = 0 V

# Three phase voltages produced by the salient pole generator

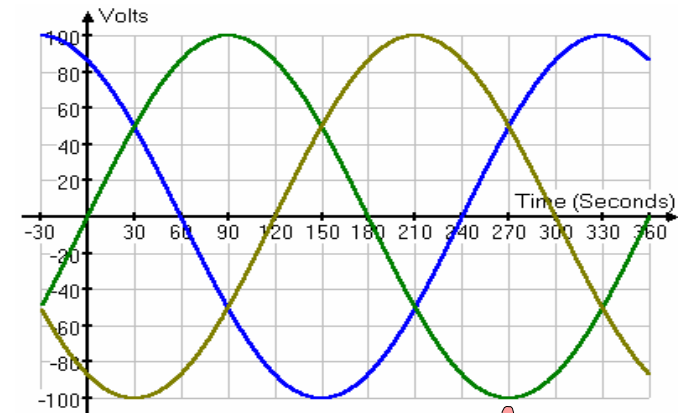
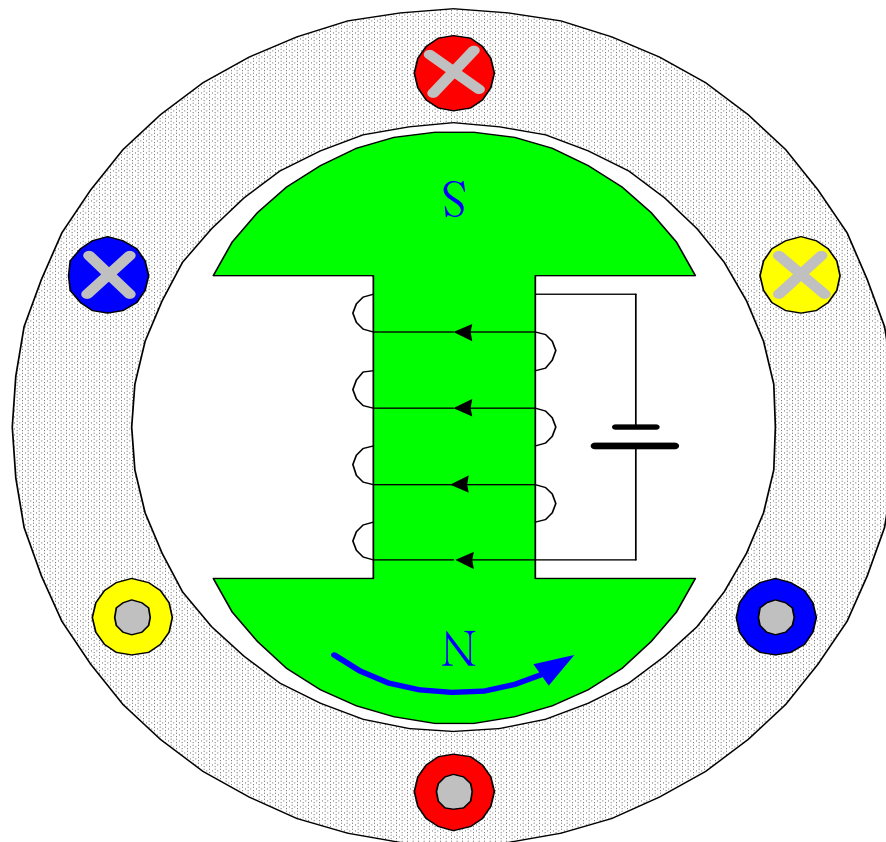

Time :  $t = 270 \text{ sec}$

- Red phase = -100 V
- Yellow Phase = +50 V
- Blue Phase = +50 V

# Three phase voltages produced by the salient pole generator

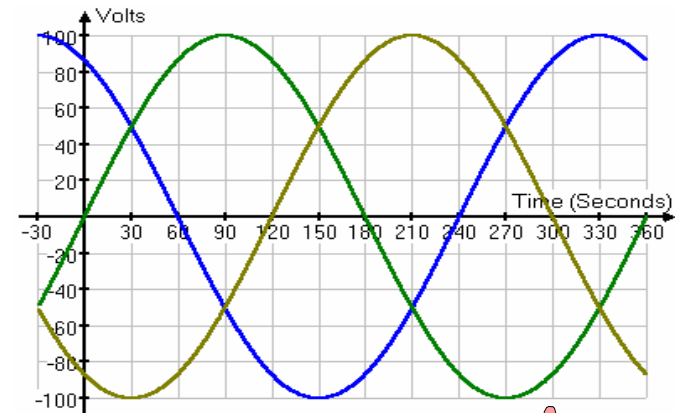
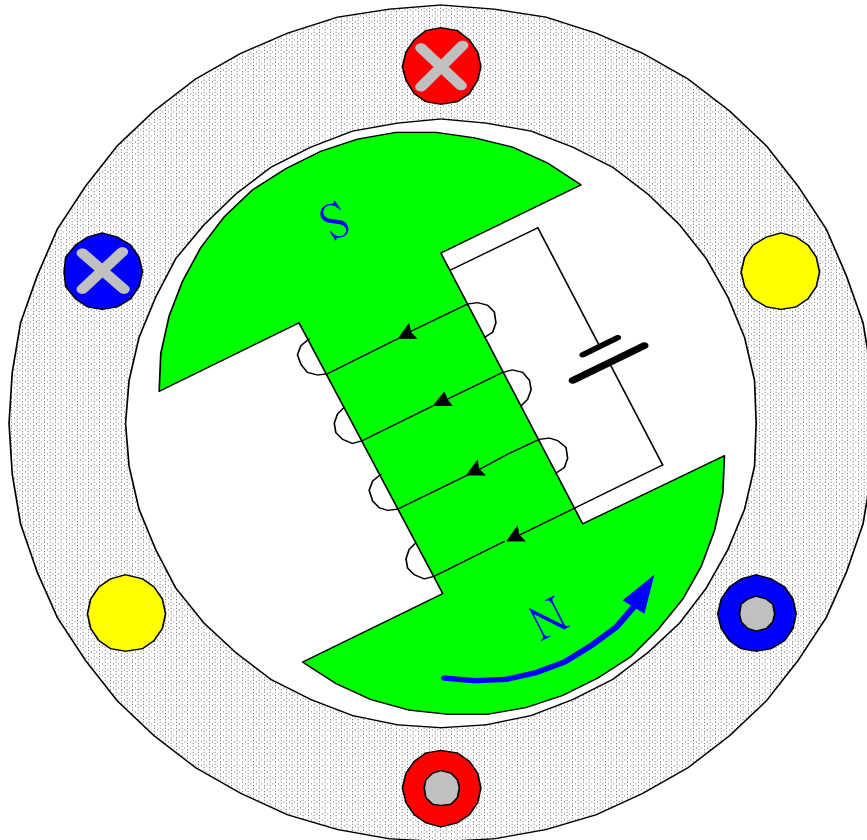

Time :  $t = 300 \text{ sec}$

- Red phase = -86.6 V
- Yellow Phase = 0 V
- Blue Phase = +86.6 V

# Three phase voltages produced by the salient pole generator

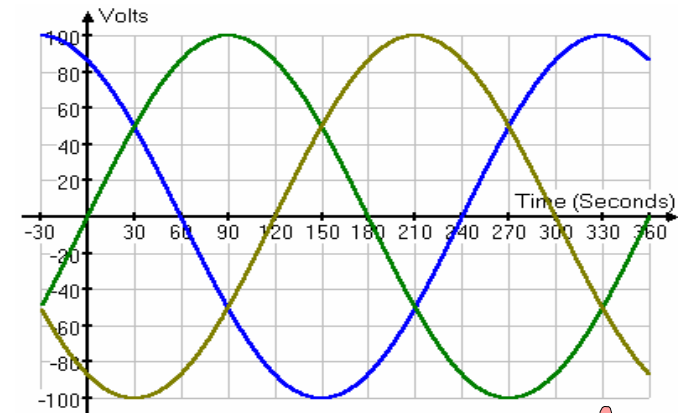
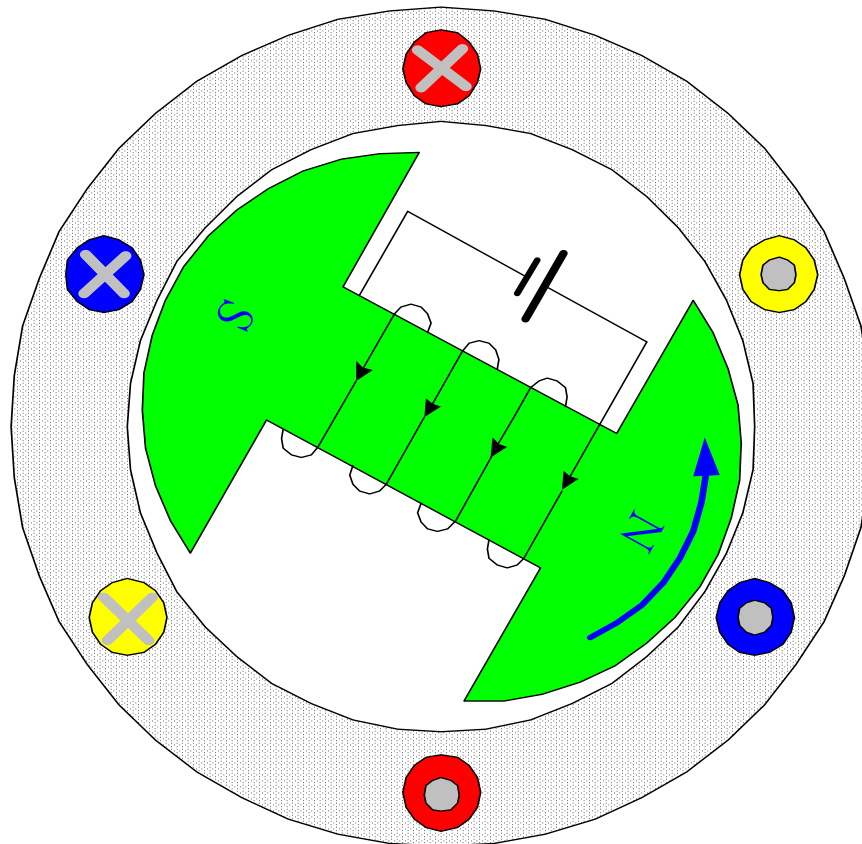

Time :  $t = 330 \text{ sec}$

- Red phase = -50 V
- Yellow Phase = -50 V
- Blue Phase = +100 V

# Three phase voltages produced by the salient pole generator

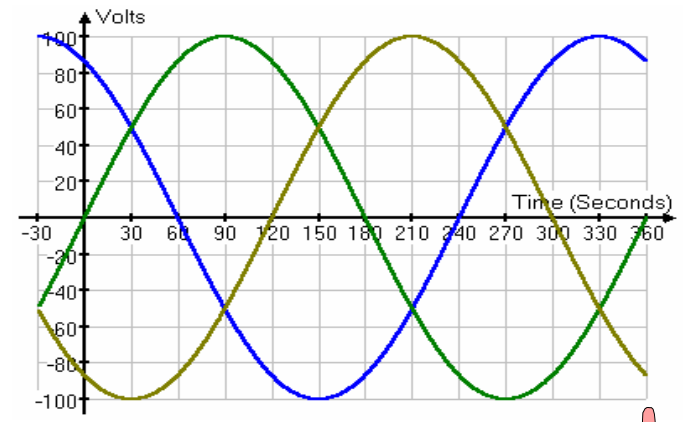
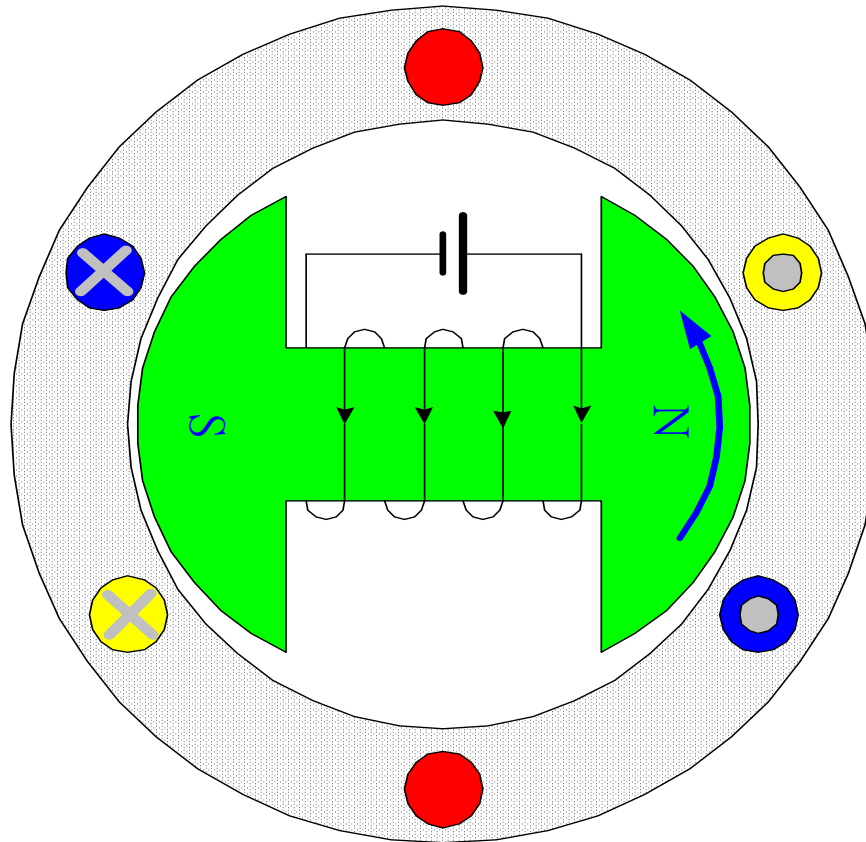

Time :  $t = 360 \text{ sec}$

- Red phase = 0 V
- Yellow Phase = -86.6 V
- Blue Phase = +86.6 V

## Voltage Regulation for a synchronous generator

- Voltage regulation for a synchronous generator is defined as the change in terminal voltage when full load in kVA at a given power factor is removed, the field excitation remains constant

- Per Cent Regulation 
$$= \frac{V_{NL} - V_{FL}}{V_{FL}} \times 100\%$$

- $V_{NL}$  is the no-load terminal voltage produced by rotor excitation

$V_{FL}$  is the rated full load terminal voltage, which is usually the voltage at the infinite busbar



## Variation of terminal voltage with load (synchronous generator)

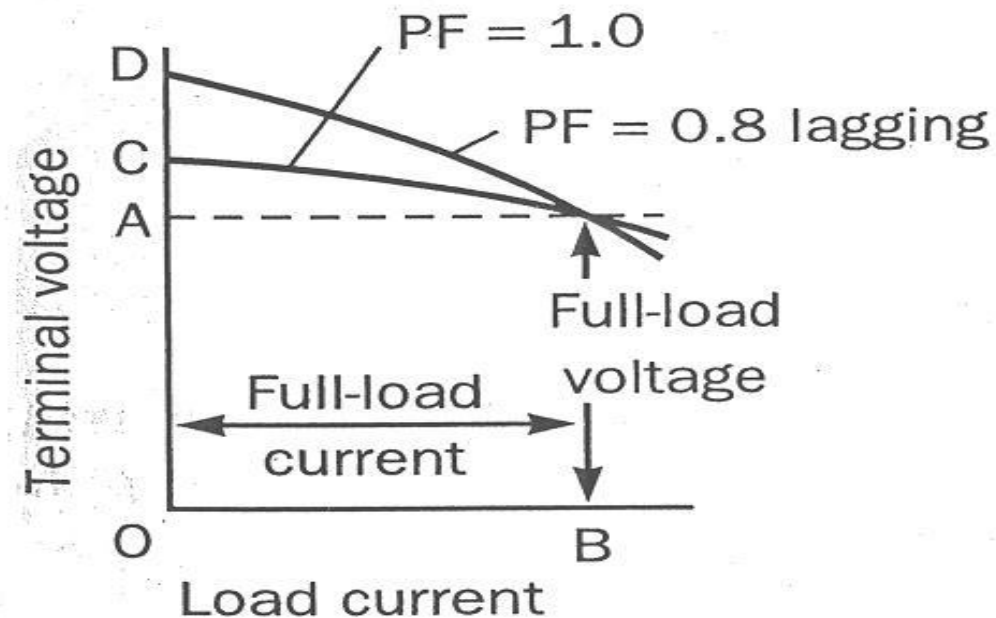

Variation of terminal  
voltage with load

## Advantages of the synchronous motor:

1. The ease of which the power factor can be controlled.
2. The speed is constant and independent of the load.

## Disadvantages of the synchronous motor:

1. The cost per kilowatt is generally higher than that of an induction motor.
2. A d.c. supply is necessary for the rotor excitation.
3. Some arrangements must be provided for starting and synchronizing the motor.

## Methods to start a Synchronous Motor

1. Use a variable - frequency supply or
2. Start the machine as an induction motor.

# EEE3441 Electrical Machines

## Department of Electrical Engineering

| **END of Lecture** |

# Introduction to Electrical Machines