



IDONiAL

TECHNOLOGY CENTRE



REFERENCE BLOCKS FOR NDT

Experts in manufacturing customised
blocks with induced flaws

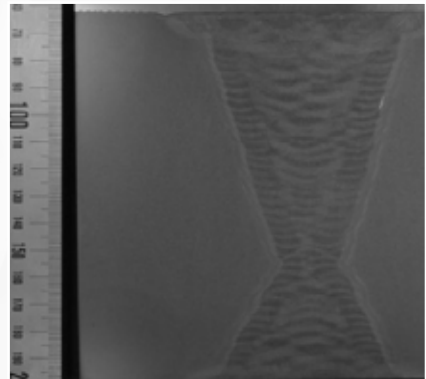
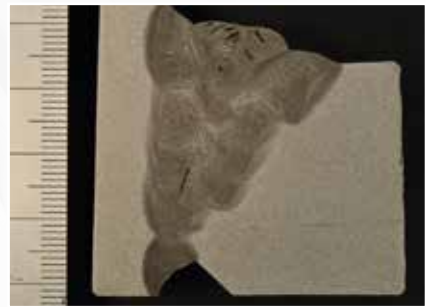









CONTENTS

INTRODUCTION	4
TRAINING KITS	5
FLAWED SPECIMEN TESTS	8
STANDARD FLAWED SPECIMENS	11
CUSTOM SPECIMENS AND MOCK UPS	21
ASME XI APPENDIX VII SET	24
ASME XI APPENDIX VIII SET	25
DISSIMILAR WELDS	26
BEND TEST	27
BOILER TUBES	28
CRACK SIZING BARS	29
CASTING AND FORGING FLAWS	30
STANDARD UT CALIBRATION BLOCKS	31
PDI REFERENCE BLOCKS	33
CUSTOM REFERENCE BLOCKS	34
CORROSION AND EROSION	35
NON-DESTRUCTIVE TEST ADDITIVE MANUFACTURING BLOCKS FOR APPLICATION OF RADIOGRAPHY AND ULTRASOUND TECHNIQUES	36

INTRODUCTION

IDONIAL was established in 2019 as a result of the merger of the ITMA and PRODINTEC centers with 28 and 14 years of experience respectively, which have opted to join efforts to address new challenges and provide our customers with tailor-made solutions related to the development of materials, advanced manufacturing and the digital industry through technological development and innovation.

For this purpose, the centre has a wide technological offer oriented to the needs of companies applicable to a wide range of industrial sectors and with an expert and multidisciplinary team with an interest in development and innovation.

 <p>Steel and metallic alloys</p>	 <p>Biofabrication</p>	 <p>Additive Manufacturing</p>
 <p>Digital Industry</p>	 <p>Smart products and active materials</p>	 <p>Refractories, ceramics and raw materials</p>
 <p>Numerical simulation</p>	 <p>Welding and joining technologies</p>	 <p>Surfaces and coatings</p>

IDONIAL's key lines of work

Our experience in research and development in the field of steel and metallic alloys together with welding and joining technologies makes IDONIAL a reference center in provides a service for manufacturing of reference blocks for Non Destructive Tests, with induced defects.

Flawed specimens are manufactured through a wide set of techniques available at IDONIAL workshop and labs, including micromachining, EDM or controlling welding parameters. Size and location of each flaw is made and then supplied with documentation with all details for customers.

TRAINING KITS

IDONIAL is providing a set of reference blocks with different weld flaws, for flaw detection, interpretation and sizing by NDT inspection agencies for training purposes.

RECOMMENDED FOR

- Introduction to weld flaws. Detection, interpretation and sizing.

KIT CONTENTS

- 10 miniature flawed specimens, each one with one flaw
- Flaw location details
- Testing and acceptance criteria
- Macro sections

RELEVANT FOR THE FOLLOWING NDT

- Ultrasonic, TOFD and Phased Array testing
- Magnetic particle testing
- Penetrant testing
- Visual testing
- Radiographic testing

MATERIALS

- Steels: Carbon, C-Mn Structural, High T-P, Cr-Mn, Cr-Mo-V, Corrosion and Wear resistant, Cryogenic Steels...
- Stainless Steel
- Castings
- Aluminium and light alloys

Kits are sent in a durable case to avoid failures during delivery.

KIT TYPES AND CONTENTS

DEMONSTRATION KIT (IT1319DK) - 13 KG

The 1 tee and 9 plate specimens are a variety of pieces carefully selected from each of the other kits in order to provide an overview of flaw types and their detection using various non-destructive testing techniques.

ULTRASONIC KIT (IT1219) - 12 KG

The 1 tee and 9 plate specimens contain a selection of commonly occurring surface-breaking and weld-body flaws.

MAGNETIC PARTICLE (IT1237M) & PENETRANT KIT (IT1237P) - 12 KG

The 3 tee and 7 plate specimens contain a selection of commonly occurring surface-breaking flaws.

VISUAL KIT (IT1237V) - 12 KG

The 3 tee and 7 plate specimens contain a selection of commonly occurring visual welding flaws and irregularities.

RADIOGRAPHIC KIT (IT1219V) - 12 KG

The 1 tee and 9 plate specimens contain a selection of commonly occurring surface-breaking and weld-body flaws.





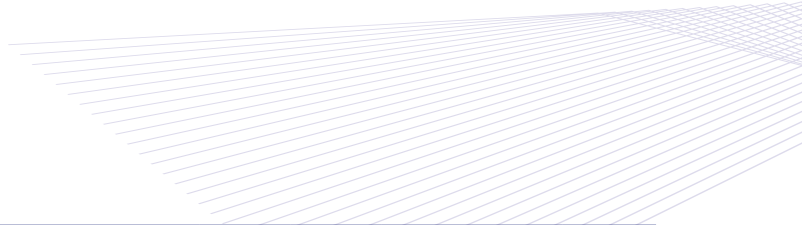



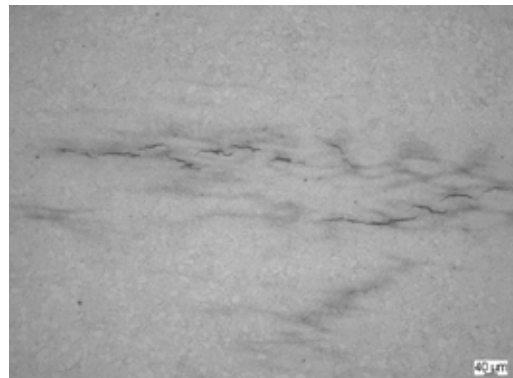



















WELD FLAW IDENTIFICATION KIT (IT730ID) - 7 KG

Contains 30 macro sections showing flaws in cross section.



FLAWS IN EACH KIT									
Acronym		Name	Piece	MT KIT	PT KIT	VT KIT	DEMO KIT	UT KIT	RT KIT
1		TOE CRACK		MT	PT		DM	UT	
1A		TOE CRACK		MT	PT				
1B		TOE CRACK		MT	PT				
1C		TOE CRACK (FULL PEN)						UT	
2		ROOT CRACK		MT	PT		DM	UT	RT
3		SIDE WALL CRACK							
4		CENTRE LINE CRACK SURFACE		MT	PT				
5		CENTRE LINE CRACK WELD BODY						UT	
6		POROSITY WELD BODY					DM	UT	RT
6A		POROSITY SURFACE BREAKING		MT	PT	VT			
7		SLAG					DM	UT	RT
8		LACK OF SIDE WALL FUSION					DM	UT	
9		LACK OF ROOT FUSION		MT	PT				



FLAWS IN EACH KIT									
Acronym		Name	Piece	MT KIT	PT KIT	VT KIT	DEMO KIT	UT KIT	RT KIT
10		ROOT CONCAVITY				VT	DM		RT
11		INCOMPLETE ROOT PENETRATION SV				VT		UT	RT
12		OVER PENETRATION				VT			RT
13		INCOMPLETE ROOT PENETRATION DV						UT	
14		LAMINATION		MT	PT				
14A		LAMINATION WELD PREPARATION		MT	PT				
14B		LAMINATION						UT	
15		IRREGULAR ROOT PENETRATION				VT	DM		RT
16		WELD SPATTER				VT			RT
17		UNDERCUT				VT			
18		EXCESS CAP				VT	DM		RT
21		CRACK SUBSURFACE WELD CAP REMOVED		MT	PT		DM		
22		CONCAVE CAP				VT			
23		UNEVEN LEG LENGTH				VT	DM		

FLAWED SPECIMEN TESTS

Manufacturing of a set of reference blocks for practical training using different NDT techniques is provided by IDONIAL. The aim is to facilitate practical training and improve skills on flaw detection, sizing and interpretation.

Sets are delivered with specimens including one or two flaws, the best approach to let operators acquire such desired skills using NDT.

RECOMMENDED FOR

- Introduction to basic flaw detection, sizing and interpretation
- Analysing weld geometries

SET CONTENTS

- 10 Small flawed specimens
- Each specimen containing 1 or 2 flaws
- Flaw location details
- Testing and acceptance criteria
- Certificate of conformance

RELEVANT FOR THE FOLLOWING NDT

- Ultrasonic, TOFD and Phased Array testing
- Magnetic particle testing
- Penetrant testing
- Visual testing
- Radiographic testing

UT/TOFD/Phase Array Set			
Description	Thickness	Width	Length
1 Plates	1	10	20
2 Plates	1	10	20
3 Plates	1	10	20
4 Plates	1,5	10	20

MT/PT & VT Set			
Description	Thickness	Width	Length
7 Plates	0,6	10	20
3 Plates	0,6	10	20

RT Set			
Description	Thickness	Width	Length
4 Plates	1	10	20
4 Plates	1,5	10	20
2 Plates	1	10	20

Dimensions above in cm.

Sets are sent in a durable case to avoid failures during delivery.

DIMENSIONS OF INDIVIDUAL SPECIMENS (centimeters)

Specimen	Thickness	Width	Diameter	Length	MT/PT & VT	RT & UT
Pipe	1	-	10	20	No	Yes
Pipe	1.8	-	15	20	No	Yes
Tee	0.6	10	-	20	Yes	No
Tee	1	10	-	20	No	Yes
Plate	0.6	10	-	20	Yes	No
Plate	1	10	-	20	No	Yes
Plate	1.5	10	-	20	No	Yes
Plate	2.5	15	-	25	No	Yes

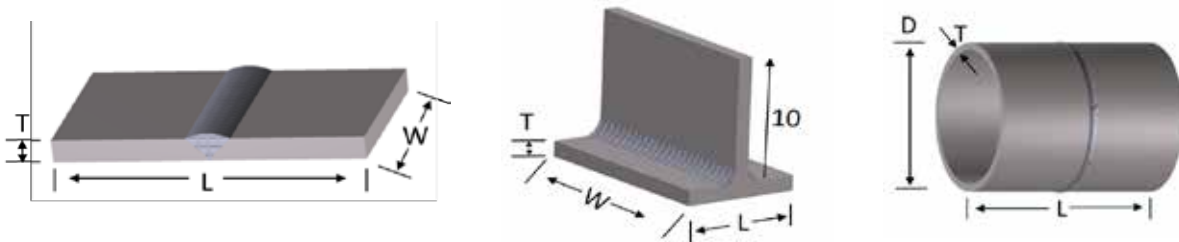

MATERIALS

	CARBON STEEL	STAINLESS STEEL	ALUMINIUM
ULTRASONIC	Yes	Yes	Yes
VISUAL	Yes	-	-
MAGNETIC	Yes	-	-
PENETRANT	Yes	Yes	Yes
RADIOGRAPHIC	Yes	Yes	Yes
SET TYPE			

SPECIMEN DETAILS

Description	Dimensions (in cms)
Flaw length range	0.3 to 6
Flaw height range	0.05 to 1.5
Flaw size tolerance	± 0.3
Specimen size tolerance	± 15%
Specimen thickness tolerance	± 10%
Specimen diameter tolerance	± 10%

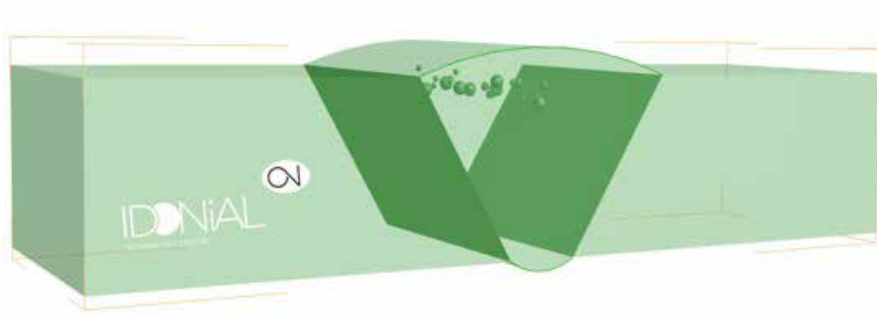

FLAW TYPES

- ✓ **Planar Flaws** (Toe Crack, Transverse Crack, Root Crack, Centre-line Crack, Side Wall Crack, Lack of side Wall fusion, lamination, crater crack).
- ✓ **Root Conditions** (Incomplete penetration, Irregular root penetration, root concavity, lack of root fusion, burn through, over penetration).
- ✓ **Volumetric Flaws** (Porosity, Surface porosity, Slag, Tungsten Inc).
- ✓ **Other Weld conditions** (Excess cap, Weld spatter, Mismatch, Cold lap, Concave cap, undercut, Incomplete Weld fill).

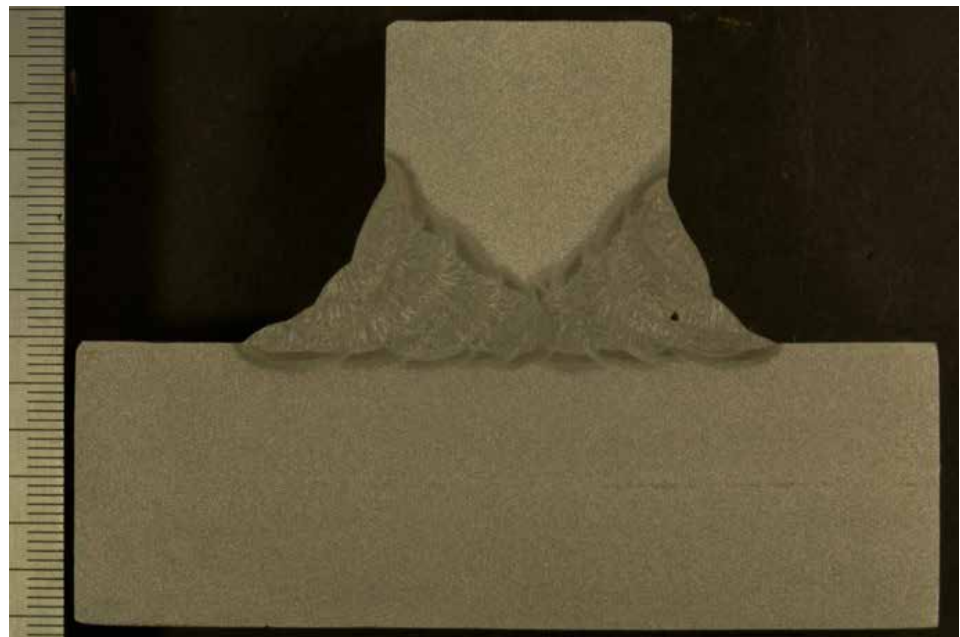

STANDARD FLAWED SPECIMENS

The design phase and all the manufacturing processes involved in the development of Standard Flawed Specimens are being done following the requirements of all known internationally recognised Qualification Programme. Thus, IDONIAL provides customers with reliable specimens for training and qualification on **weld flaw** detection, sizing and interpretation. Weld sizes and geometries are representing the most common settings.

IDONIAL provides either set of flawed specimens or individually.

INDIVIDUAL SPECIMENS

Contain three different flaw types. All of them are different in size, tags and are supported with NDT reports and acceptance/rejection criteria.

RECOMMENDED SETS

IDONIAL can arrange a selection of specimens representing the above mentioned settings, including all flaws, with 1-5 flaws per unit and with a total weld length of over 350 cm.

CUSTOM SETS

Customers can define the sets following the needs coming from recognised qualification schemes, such as API, ACCP, etc.

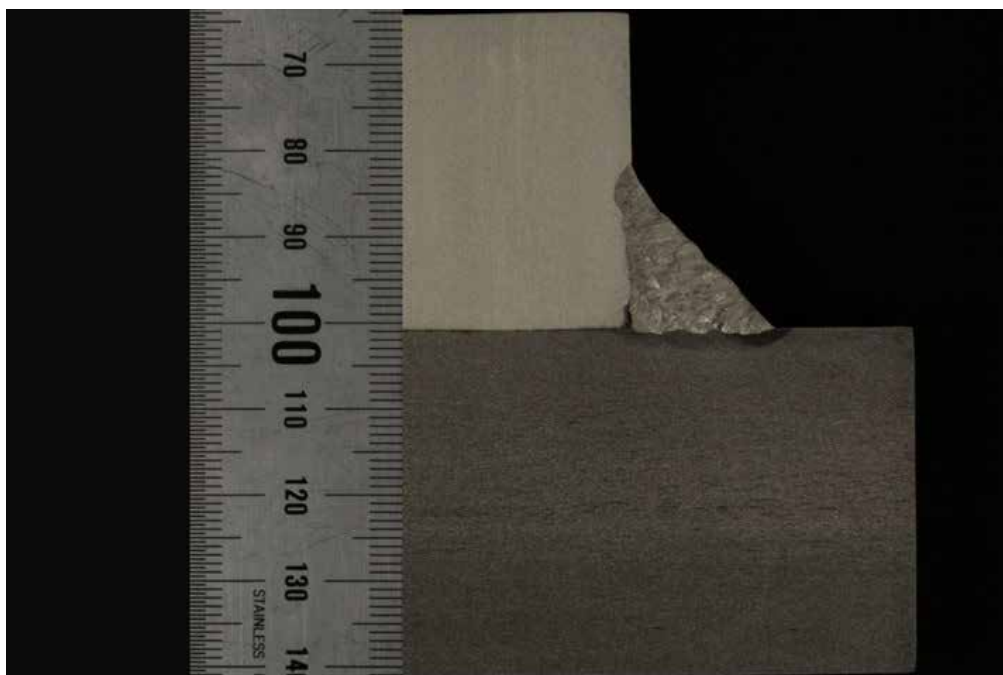

ULTRASONIC SPECIMENS

Part Number	Specimen type	Weld preparation type	INDIVIDUAL SPECIMENS			Approx weight (Kg)
			Approx dimensions (cms)			
			Diameter	Thickness	Size	
IT-UT-14			–	0.6	30x30	4
IT-UT-15			–	1.2	30x30	8
IT-UT-16			–	2.5	30x40	23
IT-UT-17			–	2	30x30	14
IT-UT-18			–	2.5	30x40	23
IT-UT-19			–	3	30x44	31
IT-UT-20			8	1.2	30 long	7
IT-UT-21			15	1.2	30 long	14
IT-UT-22			15	2.5	30 long	28
IT-UT-23			20	1.2	30 long	18
IT-UT-24			20	2.5	30 long	37
IT-UT-25			30	1.2	30 long	27
IT-UT-26			30	2.5	30 long	56
IT-UT-27					–	2
IT-UT-28	–	2.5			20x20x30	23
IT-UT-29	–	2.5			20x20x30	23
IT-UT-30	–	3			22x22x30	31
IT-UT-31			–	2.5	20x20x30	23
IT-UT-32			–	3	22x22x30	31
			Penetration (Diameter x Thickness)		Carrier plate (L x W x T)	
IT-UT-33			10x1.2		50x50x2.5	54
IT-UT-34			20x1.2		50x50x2.5	54
IT-UT-35			10x1.2		50x50x2.5	43
IT-UT-36		20x1.2		50x50x2.5	54	
			Stub (Diameter x Thickness)		Carrier plate (L x W x T)	
IT-UT-37			20x2		50x50x2.5	75
IT-UT-38			25x2		50x50x2.5	103

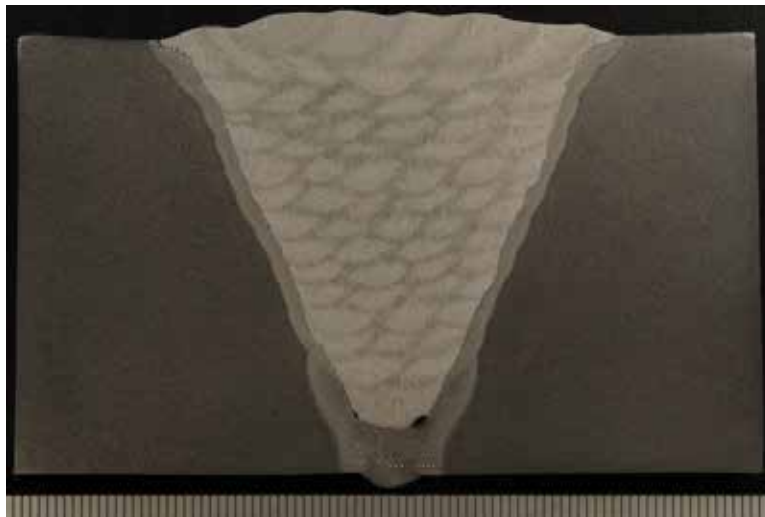

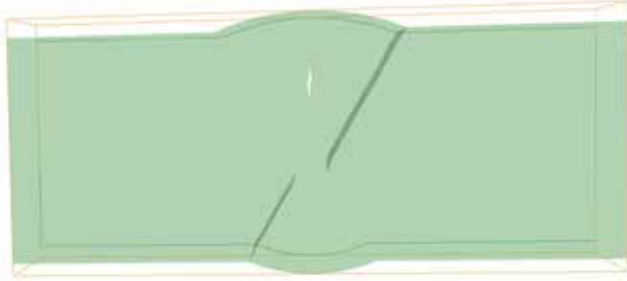

FLAW TYPES for UT Specimens

- ✓ **Planar Flaws:** Toe Crack, Transverse Crack, Root Crack, Centre-line Crack, Side Wall Crack, Lack of side Wall fusion, lamination.
- ✓ **Root Conditions:** Incomplete penetration (SV), incomplete penetration (DV), lack of root fusion.
- ✓ **Volumetric Flaws:** Slag.

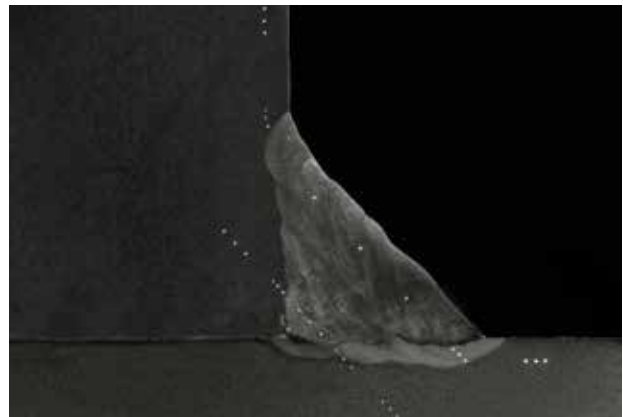

RECOMMENDED SETS

Specimen Types	Contents	Approx Weight (Kg)	Specimen Types	Contents	Approx Weight (Kg)
Set 2 IT-UT-39 	3 x UC-15	229	Set 5 IT-UT-42 	2 x UC-33	229
	1 x UC-16			2 x UC-34	
	3 x UC-17			2 x UC-35	
	2 x UC-18			2 x UC-36	
	3 x UC-19		Set 6 IT-UT-43 	"2 x UC-37	193
Set 3 IT-UT-40 	2 x UC-20	2 x UC-38			
Set 4 IT-UT-41 	1 x UC-21	193	Set 7 IT-UT-44 	1 x UC-16	211
	1 x UC-22			1 x UC-19	
	1 x UC-23			1 x UC-24	
	1 x UC-24			1 x UC-25	
	1 x UC-25			1 x UC-26	
	1 x UC-26			1 x UC-27	
Set 5 IT-UT-42 	4 x UC-27	211	Set 6 IT-UT-43 	1 x UC-30	211
	2 x UC-28			1 x UC-31	
	2 x UC-29				
	2 x UC-30				

MAGNETIC AND PENETRANT SPECIMENS

Part Number	INDIVIDUAL SPECIMENS					
	Specimen type	Weld preparation type	Approx dimensions (cms)			Approx weight (Kg)
			Diameter	Thickness	Size	
IT-MS-01	Plate 		–	1	30 x 20	5
IT-MS-02	Pipe 		8	1	20 Long	4
IT-MS-03			15	1	20 Long	8
IT-MS-04			20	1	20 Long	10
IT-MS-05			30	1	20 Long	22
IT-MS-06	Tee 		–	1	15 x 15 x 30	7
IT-MS-07	Y 		–	1	15 x 15 x 30	7
	Nozzle		Penetration (Diameter x Thickness)		Carrier plate (L x W x T)	
IT-MS-08			10 x 1		40 x 40 x 1.2	17
IT-MS-09			20 x 1		40 x 40 x 1.2	22
	Node		Stub (Diameter x Thickness)		Carrier plate (L x W x T)	
IT-MS-10			20 x 1		40 x 40 x 1.2	32
IT-MS-11			25 x 1		40 x 40 x 1.2	37
IT-PS-01	Plate 		–	1	30 x 20	5
IT-PS-02	Pipe 		8	1	20 Long	4
IT-PS-03			15	1	20 Long	8
IT-PS-04			20	1	20 Long	10
IT-PS-05			30	1	20 Long	22
IT-PS-06	Tee 		–	1	15 x 15 x 30	7
IT-PS-07	Y 		–	1	15 x 15 x 30	7
			Penetration (Diameter x Thickness)		Carrier plate (L x W x T)	
IT-PS-08			10 x 1		40 x 40 x 1.2	17
IT-PS-09			20 x 1		40 x 40 x 1.2	22
			Stub (Diameter x Thickness)		Carrier plate (L x W x T)	
IT-PS-10			20 x 1		40 x 40 x 1.2	32
IT-PS-11			25 x 1		40 x 40 x 1.2	37



FLAW TYPES for MT PT Specimens

- ✓ **Planar Flaws:** Toe Crack, Transverse Crack, Root Crack, Centre-line Crack surface, Side Wall Crack, Crater Crack.
- ✓ **Root Conditions:** Lack of root fusion. HAZ Crack.
- ✓ **Volumetric Flaws:** Surface Porosity.

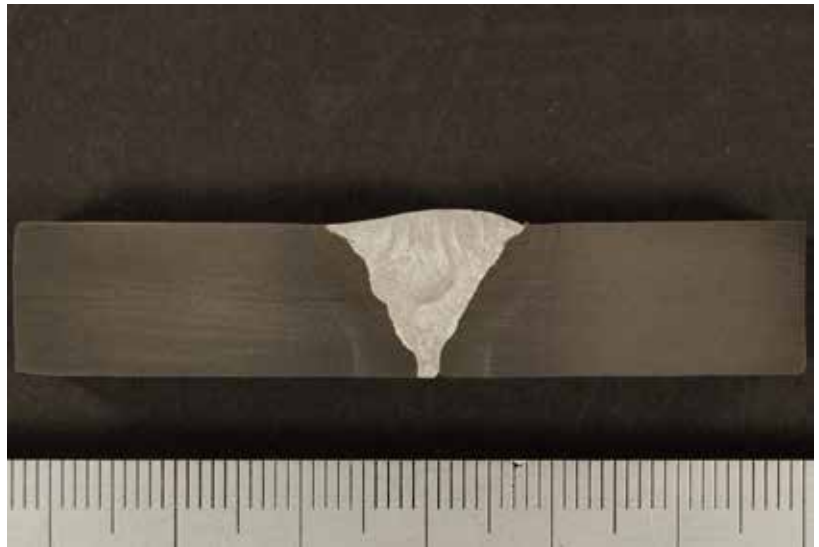

RECOMMENDED SETS

	IT-MS-12	IT-PS-12	Approx Weight (kgs) 70
	Magnetic	Penetrant	
	1 x IT-MS-01	1 x IT-PS-01	
	2 x IT-MS-03	2 x IT-PS-03	
	2 x IT-MS-05	2 x IT-PS-05	
	1 x IT-MS-06	1 x IT-PS-06	
1 x IT-MS-07	1 x IT-PS-07		

VISUAL SPECIMENS

INDIVIDUAL SPECIMENS						
Part Number	Specimen type	Weld preparation type	Approx dimensions (cms)			Approx weight (Kg)
			Diameter	Thickness	Size	
IT-VS-01	Plate 		-	1	30 X 20	5
IT-VS-02	Pipe 		8	1	20 Long	4
IT-VS-03			15	1	20 Long	8
IT-VS-04			20	1	20 Long	10
IT-VS-05			30	1	20 Long	22
IT-VS-06	Tee 		-	1	15 x 15 x 30	7
IT-VS-07	Y 		-	1	15 x 15 x 30	7
	Nozzle 		Penetration (Diameter x Thickness)		Carrier plate (L x W x T)	
IT-VS-08			10 x 1		40 x 40 x 1.2	17
IT-VS-09			20 x 1		40 x 40 x 1.2	22
	Node 		Stub (Diameter x Thickness)		Carrier plate (L x W x T)	
IT-VS-10			20 x 1		40 x 40 x 1.2	32
IT-VS-11			25 x 1		40 x 40 x 1.2	37

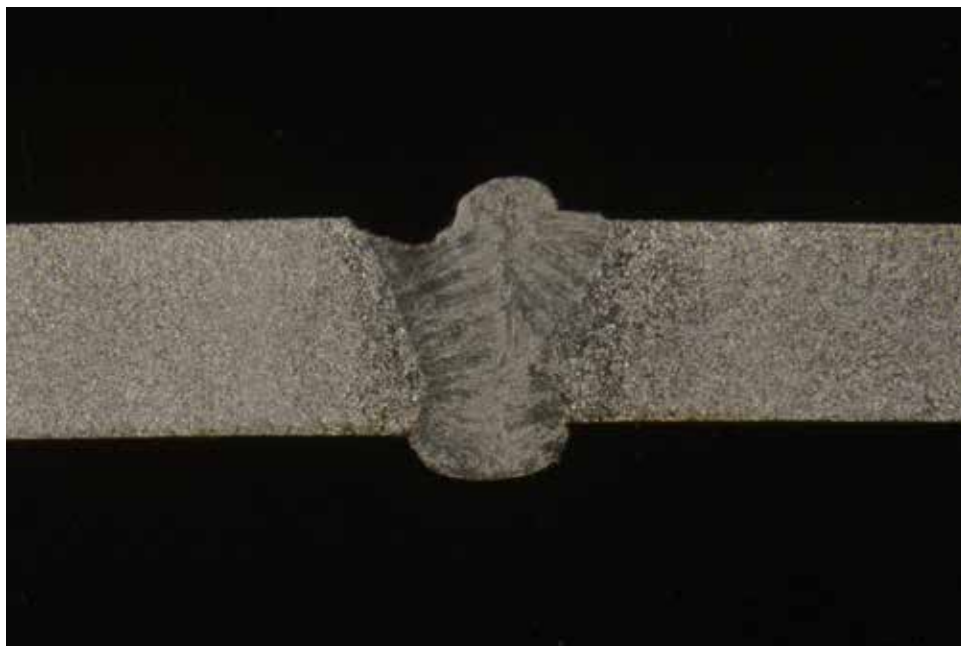



FLAW TYPES for VT Specimens

- ✓ **Planar Flaws:** Crater Crack.
- ✓ **Root Conditions:** Lack of Root fusion, Root concavity, Excess penetration, Incomplete penetration, Irregular penetration.
- ✓ **Volumetric Flaws:** Surface Porosity.
- ✓ **Other Weld conditions:** Undercut, Excessive Cap, Concave Cap, Weld Spatter.

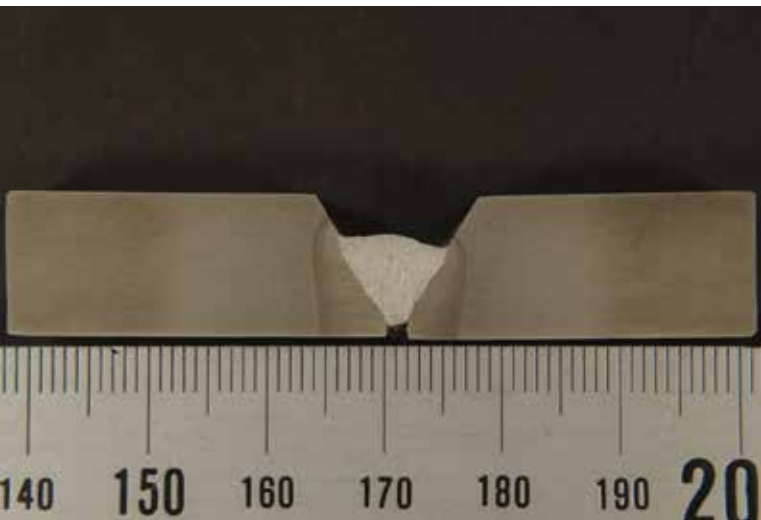







RECOMMENDED SETS

	IT-VS-12	Approx Weight (kgs) 45
	2 x IT-VS-01	
	2 x IT-VS-03	
	1 x IT-VS-05	
	1 x IT-VS-06	
	1 x IT-VS-07	

SECURE SPECIMENS

Specimens are similar to the ones shown in the individual section, by delivery is different, in order to separate samples from reports.

RADIOGRAPHIC SPECIMENS

Part Number	INDIVIDUAL SPECIMENS					
	Specimen type	Weld preparation type	Approx dimensions (cms)			Approx weigth (Kg)
			Diameter	Thickness	Size	
IT-RS-01			–	0.6	30 x 20	3
IT-RS-02			–	1	30 x 20	5
IT-RS-03			–	1.5	30 x 20	7
IT-RS-04			–	2	30 x 20	9
IT-RS-05			–	2.5	30 x 20	13
IT-RS-06			–	3	30 x 20	14
IT-RS-07			–	0.6	30 x 20	3
IT-RS-08			–	1	30 x 20	5
IT-RS-09			–	1.5	30 x 20	7
IT-RS-10			–	2	30 x 20	9
IT-RS-11			–	2.5	30 x 20	13
IT-RS-12			–	3	30 x 20	14
IT-RS-13			2.5	0.3	20 Long	0.3
IT-RS-14			5	0.5	20 Long	1
IT-RS-15			8	0.6	20 Long	2
IT-RS-16			15	0.6	20 Long	4
IT-RS-17			15	1.2	20 Long	8
IT-RS-18			20	1.2	20 Long	11
IT-RS-19			20	2	20 Long	18
IT-RS-20			30	1.2	20 Long	17
IT-RS-21			30	2.5	20 Long	33



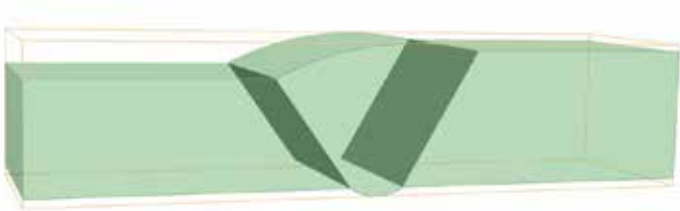

FLAW TYPES for RT Specimens

- ✓ **Planar Flaws:** Root Crack, Transverse Crack.
- ✓ **Root Conditions:** Lack of Root fusion, Incomplete penetration, Excess Penetration, Root Concavity.
- ✓ **Volumetric Flaws:** Porosity, Slag line, Tungsten Inc.
- ✓ **Other Weld conditions:** Undercut, Mismatch, Burn Through, Inclusions.

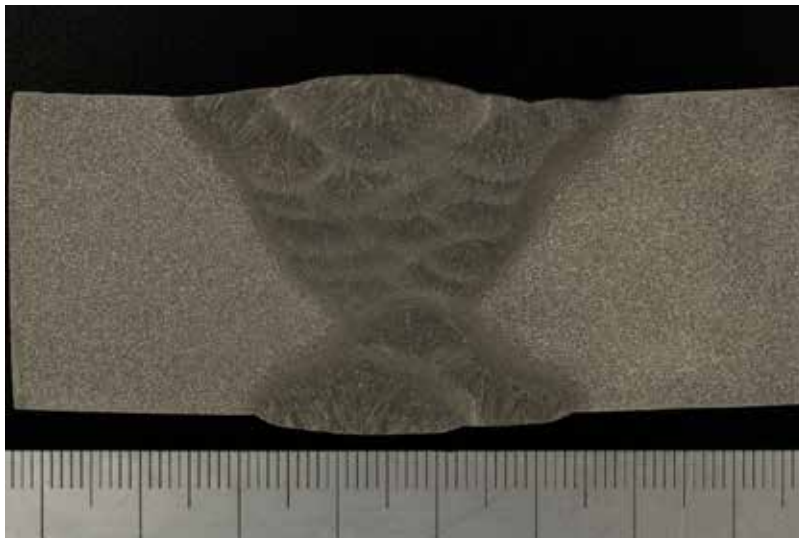

RECOMMENDED SETS

	IT-RS-22	Approx Weight (kgs) 78
	2 x IT-RS-01	
	1 x IT-RS-06	
	1 x IT-RS-07	
	1 x IT-RS-12	
	3 x IT-RS-13	
	2 X IT-RS-14	
	1 X IT-RS-15	
	1 X IT-RS-21	

STANDARD SPECIFICATIONS

IDONIAL RESERVES THE RIGHT TO ALTER SPECIFICATIONS SHOWN AT ANY TIME.

TYPES/RANGE

Flaws available depends on the type of testing being used. Check Flaw Table for details.

FLAW SIZE RANGE

Flaw length from 0,3 cm to 6 cm

Flaw through wall height 0,05 cm to 1,5 cm

FLAW TOLERANCES

Flaw length $\pm 0,3$ cm

Flaw height $\pm 0,2$ cm

Distance from datum $\pm 0,3$ cm

Depth from surface $\pm 0,2$ cm

MATERIAL TYPES

All standard-size specimens are manufactured from carbon steel, stainless steel and aluminium.

For plate, tee and Y specimens material conform to EN 10025.

Pipe specimens is to ASTM, ANSI, API or similar (Nozzles and nodes are a combination of both).

All pipe sizes are measured outside diameter.

INSPECTION

All materials are subject to 100% visual and Non-Destructive tests.

This examination process is performed for ensuring product performance.

MATERIAL TOLERANCES

Weld length for plates, tees and Ys, all 30 cm $\pm 5\%$.

Weld length for pipes, nozzles and nodes, all as per diameter.

Thickness $\pm 10\%$.

Diameters $\pm 10\%$.

SURFACE FINISH

Parent material adjacent to weld will be a suitable finish for testing the weld profile, either 'as-welded' or ground flush.

FINAL INSPECTION

All specimens are subject to accredited Visual and Non-Destructive Examination prior delivery by competent and experienced technicians.

CORROSION PROTECTION

All specimens are coated with a clear corrosion-resistant material before leaving IDONIAL.

PACKING

All export orders are suitably packed.

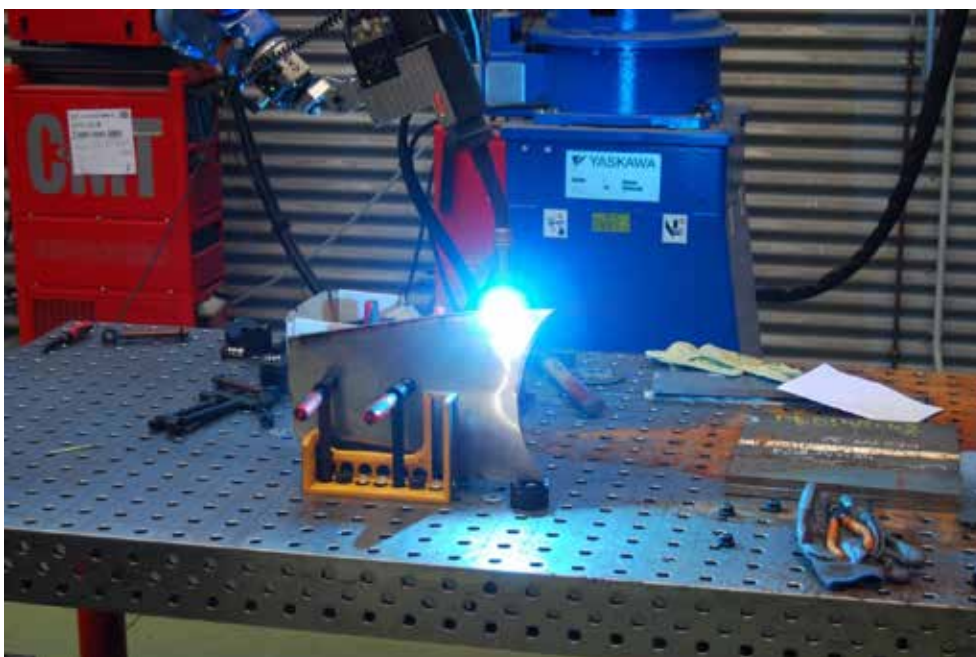

Work done for Talleres ZITRÓN S.A.

CUSTOM SPECIMENS AND MOCK UPS

IDONIAL offers full machining of products adapted to customer requirements. They can be used for specific NDT training, procedure development, staff training and qualification, specialists training and performance demonstration.

- Advanced training and qualifications
- Complex Weld geometries
- Exotic Materials
- Equipment, procedures and staff

We work with a large set of materials:

- C-Mn Structural Steels
- High T-P Steels: Cr-Mn, Cr-Mo-V
- Corrosion and Wear resistant steels
- Cryogenic Steels: Ni Base, 9% Ni
- Steels for Nuclear Industry
- Armour Steel Plate
- Alloys for Aeronautical use

All custom reference blocks are supplied with documentation which clearly identifies the flaw types, sizes and locations (flaw truth).

ALL SAMPLES ARE SUPPLIED WITH:

- As built CAD drawing
- Flaw size statement optional
- Flaw photographs
- Flaw tracings
- Inspection reports
- Material certificates
- Certificate of conformance

SPECIMEN TYPES



- Ferritic pipes
- Austenitic pipes
- Dissimilar weld metals
- Weld overlay specimens
- Reactor vessels & nozzles
- Pressuriser mock-ups
- Bolting & studs
- Erosion/Corrosion

Ideal for NDT Training and PDI Qualifications.

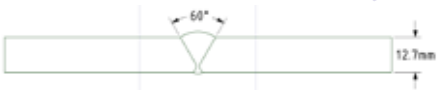
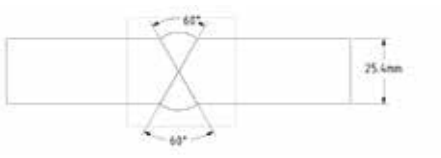
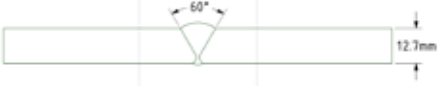

Work done for Duro Felguera
Calderería Pesada S.A.

API TRAINING & PRACTICE

UT SAMPLES	
1/2" Plate connection bevel profile (380mm weld length)	
1" Plate connection bevel profile (380mm weld length)	
8" NB x Sch. 80 (0,5" wall). Pipe connection bevel profile	
12" NB Sch. 80 (0,688" wall) Half pipe connection bevel profile	

IDONIAL can manufacture all the qualification specimens for API examinations, these specimens are ideal for training and pre-qualification practice.

Our sets are available as either training/practice sets or examination sets. In both cases the specimens are manufactured to API requirements.

Training/practice sets: Are supplied with "limited" documentation to show the flaw details.

Examination sets are exactly supplied as API for any of the qualification samples.

THE SET INCLUDES THESE FOUR SPECIMENS

(AS RECOMMENDED BY API):





- 1 0.5" Thick plate weld with single vee weld (0.5" x 9.0" x 15.0" weld length)
- 1 1" Thick plate weld with double vee weld (1.0" x 12.0" x 15.0" weld length)
- 1 8" Diameter Sch. 80 (0.5" wall) x 12" long pipe weld (360°)
- 1 12" Diameter Sch. 80 (0.688" wall) x 14" long pipe weld (180°)

Flaw size tolerance $\pm 0.080"$.

The specimens will contain these type of flaws (as recommended by API).

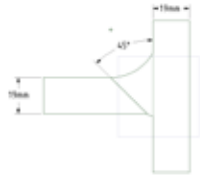
FLAWS		
Porosity	Lack of penetration	Slag inclusions
Root & Toe Cracks	Lack of fusion	Centreline Cracks
PRODUCTS		REFERENCE
Training set		API-IT-1
Examination set (secure)		API-IT-2
Optional 10% ID & OD notches		API-IT-3
Optional radiographs (full set)		API-IT-4

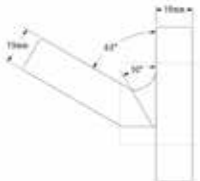
API RP 2X

UT SAMPLES	
T connection bevel profile 	Diagonal connection bevel profile 
Diagonal connection bevel profile 	Simulated pipe splice bevel profile 
16" O.D. pipe longitudinal weld bevel profile 	

IDONIAL produces a recommended practice set typical of those required in API RP 2X for advanced UT training and examination of technician in defect detection, sizing and characterisation for the offshore industry.

This set contains 3 welding set-up configurations of your choice.

Each sample contains 2-4 defects.

TYPICAL DEFECTS:

- Slag inclusion
- Lack of fusion
- Lack of penetration
- Cracks
- Pores

DOCUMENT PACKAGE INCLUDES:

- CAD as built drawing
- Manual UT and PT/MT report
- Material Certs
- Weld log and consumable Certs
- QA release note

ASME XI APPENDIX VII SET

Samples designed for specialist training and performance demonstration. Advanced training and qualification in defect detection, defect sizing, complex weld geometries, and exotic materials. Also for training technician on equipment and procedures.

This set consist of 8 samples containing a minimum of 20 defects.

- 1. 2 plates, 1 Carbon steel weld. 1 stainless steel weld. Size 12.5 mm WT x 250 mm wide x 300 mm weld length.
- 2. 2 plates, 1 Carbon steel weld. 1 stainless steel weld. Size 25 mm WT x 300 mm wide x 300 weld length.
- 3. 1 pipe weld stainless steel. Size 2" sch160 300 mm long
- 4. 1 pipe weld carbon steel. Size 4" sch160 300 mm long
- 5. 1 pipe weld stainless steel. Size 6" sch160 300 mm long
- 6. 1 pipe weld carbon steel. Size 10" sch160 300 mm long (180 degree segment)

These custom specimens are supplied with documentation which clearly identifies the flaw types sizes and locations (Flaw truth).



FLAW TYPES for ASME XI Appendix VII Set

- ✓ **Planar Flaws:** Root Crack, Centre-line Crack Surface.
- ✓ **Root Conditions:** Lack of Root fusion, Incomplete penetration (SV).
- ✓ **Volumetric Flaws:** Slag.
- ✓ **Other Weld conditions:** Misalignment, Offset Caps.

DOCUMENT PACKAGE INCLUDES

- CAD as built drawing
- Flaw size statement
- Flaw photograph and tracing
- Manual UT and PT report
- Material Certs
- Weld log and consumable Certs
- QA release note

Optional:

- Radiographs
- 10% calibration notches (POA)
- Relevant Calibration block
- Lockable storage container

ASME XI APPENDIX VIII SET

A set of samples designed for Specialist training for ASME boiler & pressure vessel code, section XI, appendix VIII.

Advanced training and qualification in crack detection, crack sizing in complex weld geometries and alternative material. Also for training technician on equipment and procedures.

IDONIAL produces 3 different material sets. In carbon steel, austenitic or dissimilar weld metal joints.

Each set contains 5 pipe samples and 10 ID breaking cracks per set (except for the dissimilar metal welds set contains 15 cracks).

- 1. 1 pipe weld. Size 2" sch80 600mm long (not included in the dissimilar set)
- 2. 1 pipe weld. Size 4" sch80 600mm long
- 3. 1 pipe weld. Size 6" sch160 600mm long
- 4. 1 pipe weld. Size 8" sch80s 600mm long (only included in the dissimilar set)
- 5. 1 pipe weld. Size 12" sch80s 600mm long
- 6. 1 pipe weld. Size 24" sch80s 600mm long (120 degree segment)

These custom specimens are supplied with documentation which clearly identifies the crack sizes and locations. (Flaw truth).

DOCUMENT PACKAGE INCLUDES

- CAD as built drawing
- Flaw size statement
- Flaw photograph and tracing
- Manual UT and PT report
- Material certs
- Weld log and consumable certs
- QA release note

Optional:

- Radiographs
- 10% calibration notches (POA)
- Relevant Calibration block
- Lockable storage container

DISSIMILAR WELDS

IDONIAL have developed procedures to overcome the challenges coming from these welded specimens, and produce high quality specimens with accurate flaws.

We have both the experience and capability and manufacture either individual or a set of specimens, which are customised following your specific requirements.

RECOMMENDED FOR

- Advanced training and qualification
- Performance Demonstration
- Flaw detection and sizing
- Complex weld geometries
- Alternative materials
- Equipment, procedures and personnel

ALL SPECIMENS ARE SUPPLIED WITH

- As built CAD drawing
- Flaw size statement
- Certificate of conformance
- A unique number
- Inspection reports
- Material certificates

Optional:

- Flaw photographs
- Flaw tracings

BEND TEST

IDONIAL has produced a range of bend test samples that can show a student or technician the impact welded defects can have on the structural integrity of a welded joint. We supply them in batches of 5 bars (12 mm × 10 mm × 200 mm long).

Each bar has 1 defect in it.

Bar 1 LoSWF

Bar 2 Slag

Bar 3 Clear

Bar 4 LoRF

Bar 5 Toe Crack

Each bar is bend until the weld starts to fail and the defect is exposed.

LACK OF FUSION FLAWS		CRACKS	
Item	Thickness	Item	Thickness
IT BT Plate 1	12 mm	IT BT Plate 4	12 mm
IT BT Plate 2	15 mm	IT BT Plate 5	15 mm
IT BT Plate 3	20 mm	IT BT Plate 6	20 mm



BOILER TUBES

IDONIAL has designed a range of boiler tube sample to help in the training and examination of technician and equipment.

IDONIAL standard boiler tube pack contains 10 Carbon steel pipes, 50 mm OD diameter x 5mm WT with range of defects listed in the BS code for boiler tube inspection. Defects include Toe crack, Root crack, HAZ crack, Centre line crack, incomplete penetration, lack of root fusion, lack of side wall fusion, lack of inter run, tungsten insert, porosity, gas pores, inclusions, wormhole, undercut, excessive penetration and misalignment.

These packs can also be customised, to smaller or larger packs of boiler tubes. Materials can be low alloy or high alloy. IDONIAL adapts the product to customer requirements regarding material size, tube diameter and wall thickness or the type of defects.

THE STANDARD PACKAGE INCLUDES:

- CAD as built drawing
- Manual UT and PT report
- Material Certs
- Weld log and consumable Certs.
- QA release note

Optional:

- PA report
- Radiography

CRACK SIZING BARS

IDONIAL produces a range of sizing bars they are a useful tool for crack sizing and characterisation.

Standard sizes are weld length 30 mm × width 300 mm in a range of wall thicknesses, 12 mm, 20 mm, 25 mm and 30 mm.

They can be made in a wide set of materials, including carbon steel or stainless steel.

The mechanically induced cracks run the full 30 mm weld length, are mechanical induced cracks and come in percentage through wall height. The recommended set would contain 4 blocks.

See table:

REFERENCE	WALL THICKNESS	THROUGH WALL HEIGHT			
IT-CSB-1	12 mm	10%	25%	50%	75%
IT-CSB-2	20 mm	10%	25%	50%	75%
IT-CSB-3	25 mm	10%	25%	50%	75%
IT-CSB-4	30 mm	10%	25%	50%	75%

IDONIAL can customise these block to customer request.

CASTING AND FORGING FLAWS

IDONIAL has developed a series of small and lightweight specimens which contain typical flaws found in cast and forged components.

The specimens are designed for practical training to provide experience in flaw detection, sizing and interpretation. Customised specimens are available on request.

THE SPECIMENS PROVIDE

- Basic flaw detection and sizing
- Representative geometries

SPECIMENS TO CHOOSE FROM

- Flange Blank, Ingot & Ingot Blank
- Stud
- Wasted Bolt
- Tee Blank
- 4 Spigot Blanks
- Recessed Flange
- Tapered Ingot Blank

RECOMMENDED SET CONTAINS

- 12 individual specimens
- An average of 20 flaws
- Total weight of 59 kg

METHODS







- Ultrasonic testing
- Magnetic particle testing
- Penetrant testing

IDONIAL casting and forgings are available either individually or in sets.

INDIVIDUAL SPECIMENS

- Contain up to 3 flaws
- Are unique – no two specimens are the same
- Are individually numbered and supplied with:
 - Drawing/NDT report
 - Testing and acceptance criteria
 - Certificate of conformance









STANDARD UT CALIBRATION BLOCKS



CALIBRATION BLOCKS					
Reference	Shape	Type	Description	Related Standard	Size
IT-CB-01		No. 1 EU Standard	No.1 Calibration Standard. Calibration of shear and compression wave probes. Checking beam angles, emergent point and resolution. Calibration of time base and gain settings. 3mm target holes	EN ISO 2400 2012 Tolerance ± 0.1 mm	25mm x 100mm x 300mm Weight 5.2Kg (Optional up to 10.4Kg with 50mm thickness)
IT-CB-02		V1 - A2	V1 Calibration Standard. Calibration of shear and compression wave probes. Checking beam angle, emergent point and resolution. Calibration of time base and gain settings. 1.5 target hole.	EN 12223 2000 BS 2704 Tolerance ± 0.1 mm	25mm x 100mm x 300mm Weight 5.6Kg (Optional up to 10.8Kg with 50mm thickness)
IT-CB-03		No.2 ISO & EU Standard	No.2 Calibration Standard. Small calibration block for site checking of shear wave probes, time bases and gain settings. 5mm target hole.	EN ISO 7963 2010 Tolerance ± 0.1 mm	12.5mm x 43mm x 75mm Weight 0.22Kg (Optional up to 0.35Kg with 20mm thickness)
IT-CB-04		V2 - A4	V2 Calibration Standard. Small calibration block for site checking of shear wave probes, time bases and gain settings. 1.5mm target holes	BS 2704 Tolerance ± 0.1 mm	12.5mm x 43mm x 75mm Weight 0.22Kg (Optional up to 0.35Kg with 20mm thickness)
IT-CB-05		BCB/BCB-N-A5	Beam calibration Block. Beam profile and resolution checks for shear wave probes. Sensitivity checks for shear and compression probes. 9 off 1.5mm diameter holes. BCB-N contains four additional 1.5mm diameter holes	BS 2704 Tolerance ± 0.1 mm	50mm x 75mm x 305mm Weight 9Kg
IT-CB-06		A6	Evaluating dominant frequency, pulse length, dead zone and resolution power for shear and compression probes	BS 2704 Tolerance ± 0.1 mm	25mm x 50mm x 150mm Weight 1.5Kg

SPECIAL CALIBRATION BLOCKS



Full machining of blocks adapted to customer requirements. Up to 45 Kg
Material is UT tested before use
Samples are heat treated and checked for acoustic characteristics
Price defined once applied

CALIBRATION BLOCKS					
Reference	Shape	Type	Description	Related Standard	Size
IT-CB-07		RTB A7	Checking shear wave probe resolution, Steps 1, 2, 3, 4 and 5 mm	BS 2704 Tolerance ± 0.1 mm	74 mm radius 74 mm thick 4 kg
IT-CB-08		MU - SPECIAL	Metric Universal Block For general purpose checking as No.1 block	Tolerance ± 0.1 mm	20 mm x 50 mm x 155 mm 1.5 kg
IT-CB-09		TBR 2 125 SPECIAL	Radiused Test Block For calibration of boiler probes Available with 3 or 5 x 1.5 mm diameter holes	Tolerance ± 0.1 mm	25 mm x 20 mm x 165 mm 0.6 kg
IT-CB-10		LSW SPECIAL	Ladder Step Wedge For time based calibration with thickness measuring compression probes. 8 steps from 1 mm to 8 mm. Plus thickness step of 15 mm and notch at 20 mm depth	Tolerance ± 0.1 mm	8 mm x 15 mm x 120 mm 0.07 kg
IT-CB-11		LSW/M SPECIAL	Generally as LSW with 25 mm diameter steel inserts mounted in plastic. 8 steps from 1 to 8mm. Also available in other step sizes	Tolerance ± 0.1 mm	10 mm x 20 mm x 140 mm 0.27 kg
IT-CB-12		CSW SPECIAL	Curved Step Wedge. For time based calibration of thickness measuring probes. 5 steps - 2, 4, 6, 8 and 10mm	Tolerance ± 0.1 mm	100 mm Long x 300 I.D Quadrant 0.14 Kg
IT-CB-13		ASME (Specify Thickness)	Setting sensitivity levels for weld testing. Sizes and locations of flaws are dependent on weld thickness. Metric or Imperial	ASME Section V Tolerance ± 0.1 mm	Size dependent on weld thickness
IT-CB-14		DAC (Specify Thickness) SPECIAL	Setting DC characteristics for shear wave and compression wave probes. Flaws typically 3mm diameter holes at 20%, 40%, 60% and 80% of thickness	(BS3923 1986) Tolerance ± 0.1 mm	Size dependent on weld thickness

EDDY CURRENT CALIBRATION BLOCKS		
		
Standard Test Block (0.2, 0.5, 1mm deep)	Profiled notches in curved samples	Notches in Tubes and Bars Longitudinal and transverse
Precision EDM and machining of notches and holes		
All blocks are supplied with fully traceable certification and optional cases		
Most standard blocks are ex stock		
Quality assurance		
Quotes during application		

PDI REFERENCE BLOCKS

IDONIAL's in-depth knowledge of Non-Destructive Testing and Performance Demonstration provides a unique insight into the requirements of these specialty reference blocks for advanced calibration of inspection equipment prior to PDI of pipe welds in the energy industry.

IDONIAL OFFERS A RANGE OF BLOCKS INCLUDING

- 2" Circumferential
- 2" Contour
- 4" Circumferential
- 4" Contour
- 6" Axial
- 6" Contour
- 8" Axial
- 8" Circumferential
- 12" Pipe segment
- 12" - 24" Contour
- 24" Pipe segment

THE BLOCKS ARE

- Machined to exacting standards
- Supplied with a CAD drawing
- Custom made to your exact requirements
- Uniquely numbered

Customised blocks are available on request.

IDONIAL also offer PDI Alternative ASME calibration blocks.

CUSTOM REFERENCE BLOCKS

IDONIAL has extensive experience in manufacturing custom blocks to meet your exact requirements.

Our capabilities include NDE, Mechanical Inspection, CAD, Specialist Welding, Cladding Overlay, Machining, etc.

WE MANUFACTURE THE FOLLOWING REFLECTOR TYPES

- Slots
- Notches
- Side Drilled Holes
- Flat Bottom Holes

For a quotation please supply specification, detailed drawings, code requirements and material type/grade.



Work done for Duro Felguera Calderería Pesada S.A.

CORROSION AND EROSION

The inspection and management of corrosion and erosion is one of the major lasting issues facing pre and in-service inspection.

New testing methods such as Corrosion Under Insulation (CUI) and UT Corrosion.

IDONIAL is taking advantage of its wide knowledge in the matter, where the Surface Integrity and Corrosion unit has been working for more than 20 years, and we are able to support the development of expertise in corrosion and erosion with real flaws in the following specifications in pipe and plate specimens:

- Erosion
- Corrosion
- Pitting



NON-DESTRUCTIVE TEST ADDITIVE MANUFACTURING BLOCKS FOR APPLICATION OF RADIOGRAPHY AND ULTRASOUND TECHNIQUES:

One recent challenge for the Additive Manufacturing processes is the development of new Non Destructive Test (NDT) procedures for inspection and materials characterization for these new manufacturing techniques. IDONIAL can produce proper AM pieces with controlled induced defects like pores or lack of fusion inside the AM parts so NDT devices could be calibrated properly and according to most strict requirements.

- Wire arc additive manufacturing (WAAM): Ti6Al4V, aerospace aluminum alloys, Nickel base material, austenitic stainless steel, Carbon steels.
- Laser powder bed fusion (L-PBF): Ti6Al4V, AISi10Mg, Nickel base (Inconel 718/625), precipitation-hardening stainless steel (15-5PH, 17-4PH), Austenitic Stainless Steel (316L), CobaltChromium alloys, low carbon steel (maraging steel).



Ti6Al4V-WAAM-parts developed at Idonial workshop

CONTACT:

Strategy & Business Development Unit

Email: info@idonial.com

www.idonial.com

HEADQUARTERS

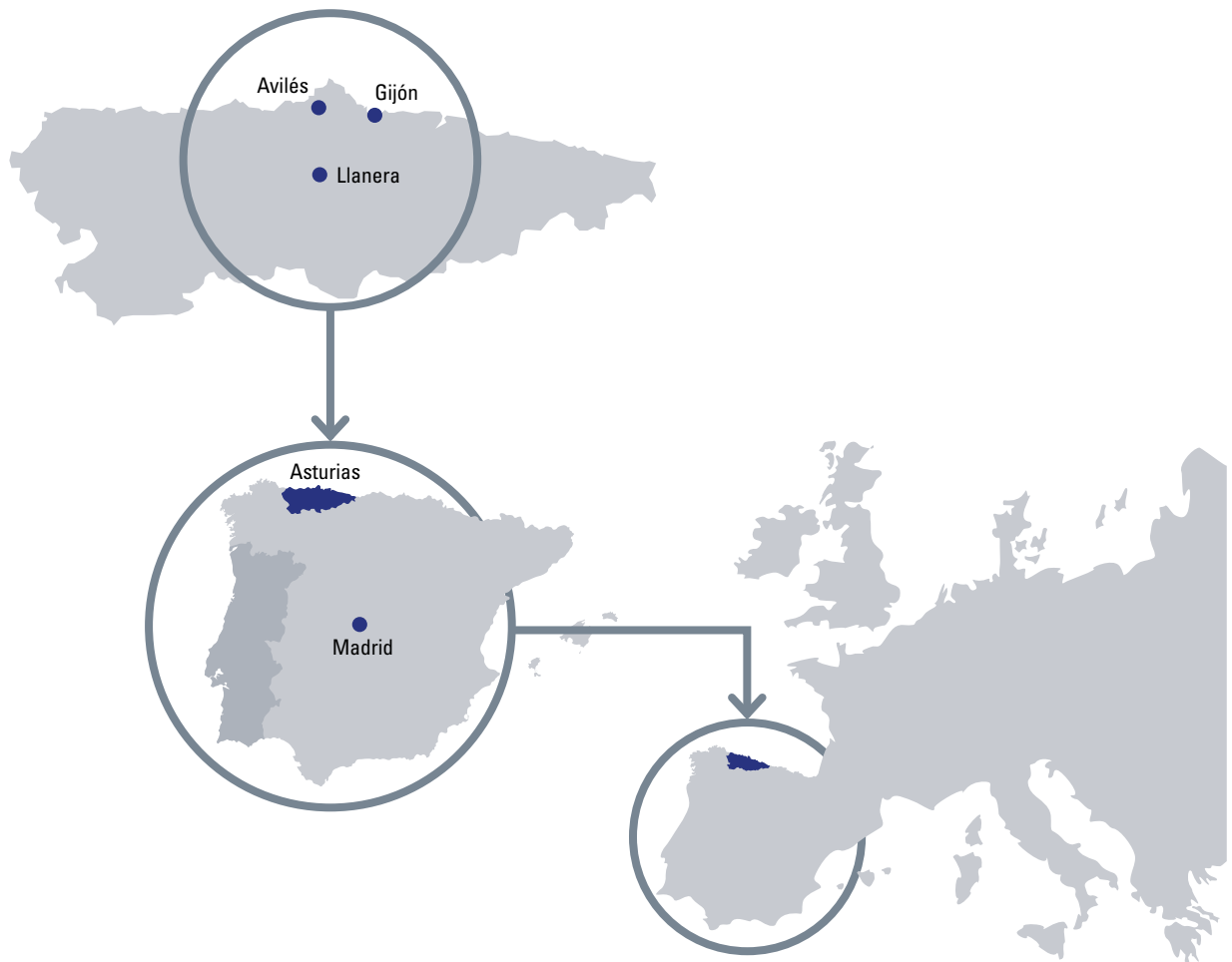

LOCATION

IDONIAL's counts with the following locations around Spain:

GIJÓN HEADQUARTERS

Parque Científico Tecnológico de Gijón,
zona INTRA
Avda. Jardín Botánico, 1345
33203 Gijón.
Asturias. España
T. +34 984 390 060

AVILÉS

Parque Empresarial Principado de Asturias
C/ Calafates 11, Parcela L-3.4
33490 Avilés.
Asturias. España
T. +34 985 129 120

LLANERA

Parque Tecnológico de Asturias
33428 Llanera.
Asturias. España
T. +34 985 980 058

MADRID

Parque Tecnológico de Leganés
Avda. Gregorio Peces-Barba, 1
Departamento 11B07
28919 Madrid. España
T. +34 911 260 504