

REFERENCED SPECIFICATIONS, CODES AND STANDARDS

The following documents are referenced in the Open Web Steel Joists, K-Series, Longspan and Deep Longspan Steel Joists, LH-and DLH-Series and Joist Girder Specifications:

American Institute of Steel Construction, Inc. (AISC) (2005), *Specification for Structural Steel Buildings*, Chicago, IL.

American Iron and Steel Institute (AISI) (2001), *North American Specification for Design of Cold-Formed Steel Structural Members*, Washington, D.C.

American Society of Civil Engineers (ASCE) (2002), *Minimum Design Loads for Buildings and Other Structures*, ASCE 7-02, Reston, VA.

American Society of Testing and Materials (2004), ASTM A6/A6M-04b, Standard Specification for General Requirements for Rolled Structural Steel Bars, Plates, Shapes, and Sheet Piling, West Conshohocken, PA.

American Society of Testing and Materials (2004), ASTM A36/A36M-04, Standard Specification for Carbon Structural Steel, West Conshohocken, PA.

American Society of Testing and Materials (2004), ASTM A242/242M-04, Standard Specification for High-Strength Low-Alloy Structural Steel, West Conshohocken, PA.

American Society of Testing and Materials (2004), A307-04, Standard Specification for Carbon Steel Bolts and Studs, 60 000 PSI Tensile Strength, West Conshohocken, PA.

American Society of Testing and Materials (2003), ASTM A370-03a, Standard Test Methods and Definitions for Mechanical Testing of Steel Products, West Conshohocken, PA.

American Society of Testing and Materials (2004), ASTM A529/A529M-04, Standard Specification for High-Strength Carbon-Manganese Steel of Structural Quality, West Conshohocken, PA.

American Society of Testing and Materials (2004), ASTM A572/A572M-04, Standard Specification for High-Strength Low-Alloy Columbium-Vanadium Structural Steel, West Conshohocken, PA.

American Society of Testing and Materials (2004), ASTM A588/A588M-04, Standard Specification for High-Strength Low-Alloy Structural Steel with 50 ksi [345 MPa] Minimum Yield Point to 4-in. [100-mm] Thick, West Conshohocken, PA.

American Society of Testing and Materials (2004), ASTM A606-04, Standard Specification for Steel, Sheet and Strip, High-Strength, Low-Alloy, Hot-Rolled and Cold-Rolled, with Improved Atmospheric Corrosion Resistance, West Conshohocken, PA.

American Society of Testing and Materials (2004), ASTM A1008/A1008M-04b, Standard Specification for Steel, Sheet, Cold-Rolled, Carbon, Structural, High-Strength Low-Alloy and High-Strength Low-Alloy with Improved Formability, West Conshohocken, PA.

American Society of Testing and Materials (2004), ASTM A1011/A1011M-04a, Standard Specification for Steel, Sheet and Strip, Hot-Rolled, Carbon, Structural, High-Strength Low-Alloy and High-Strength Low-Alloy with Improved Formability, West Conshohocken, PA.

American Welding Society, AWS A5.1-2004, Specification for Carbon Steel Electrodes for Shielded Metal Arc Welding, Miami, FL.

American Welding Society, AWS A5.5-96, Specification for Low Alloy Steel Electrodes for Shielded Metal Arc Welding, Miami, FL.

American Welding Society, AWS A5.17-97, Specification for Carbon Steel Electrodes and Fluxes for Submerged Arc Welding, Miami, FL.

American Welding Society, AWS A5.18-2001, Specification for Carbon Steel Electrodes and Rods for Gas Shielded Arc Welding, Miami, FL.

American Welding Society, AWS A5.20-95, Specification for Carbon Steel Electrodes for Flux Cored Arc Welding, Miami, FL.



REFERENCED SPECIFICATIONS, CODES AND STANDARDS

American Welding Society, AWS A5.23-97, Specification for Low Alloy Steel Electrodes and Fluxes for Submerged Arc Welding, Miami, FL.

American Welding Society, AWS A5.28-96, Specification for Low Alloy Steel Filler Metals for Gas Shielded Arc Welding, Miami, FL.

American Welding Society, AWS A5.29-98, Specification for Low Alloy Steel Electrodes for Flux Cored Arc Welding, Miami, FL.

Federal Register, Department of Labor, Occupational Safety and Health Administration (2001), 29 CFR Part 1926 Safety Standards for Steel Erection; Final Rule, §1926.757 Open Web Steel Joists - January 18, 2001, Washington, D.C.

Fire Resistance Directory – Volume 1 (2004), Underwriters Laboratories Inc., Chicago, IL.

Steel Joist Institute (SJI) (2006), Technical Digest #3, *Structural Design of Steel Joist Roofs to Resist Ponding Loads*, Myrtle Beach, SC.

Steel Joist Institute (SJI) (1988), Technical Digest #5, *Vibration of Steel Joist-Concrete Slab Floors*, Myrtle Beach, SC.

Steel Joist Institute (SJI) (2006), Technical Digest #6, *Structural Design of Steel Joist Roofs to Resist Uplift Loads*, Myrtle Beach, SC.

Steel Joist Institute (SJI) (1983), Technical Digest #8, *Welding of Open Web Steel Joists*, Myrtle Beach, SC.

Steel Joist Institute (SJI) (2006), Technical Digest #9, *Handling and Erection of Steel Joists and Joist Girders*, Myrtle Beach, SC.

Steel Joist Institute (SJI) (2003), Technical Digest #10, *Design of Fire Resistive Assemblies with Steel Joists*, Myrtle Beach, SC.

Steel Joist Institute (SJI) (1999), Technical Digest #11, *Design of Joist-Girder Frames*, Myrtle Beach, SC.

Steel Structures Painting Council (SSPC) (2000), *Steel Structures Painting Manual, Volume 2, Systems and Specifications*, Paint Specification No. 15, Steel Joist Shop Primer, May 1, 1999, Pittsburgh, PA.



CODE OF STANDARD PRACTICE FOR STEEL JOISTS AND JOIST GIRDERS

Adopted by the Steel Joist Institute April 7, 1931
Revised to May 1, 2000 - Effective May 03, 2005

SECTION 1. GENERAL

1.1 SCOPE

The practices and customs set forth herein are in accordance with good engineering practice, tend to ensure safety in steel joist and Joist Girder construction, and are standard within the industry. There shall be no conflict between this code and any legal building regulation. This code shall only supplement and amplify such laws. Unless specific provisions to the contrary are made in a contract for the purchase of steel joists or Joist Girders, this code is understood to govern the interpretation of such a contract.

1.2 APPLICATION

This Code of Standard Practice is to govern as a standard unless otherwise covered in the architects' and engineers' plans and specifications.

1.3 DEFINITIONS

Material. Steel joists, Joist Girders, and accessories as provided by the seller.

Seller. A company certified by the Steel Joist Institute engaged in the manufacture and distribution of steel joists, Joist Girders, and accessories.

Buyer. The entity that has agreed to purchase Material from the manufacturer and has also agreed to the terms of sale.

Owner. The entity that is identified as such in the Contract Documents.

Erector. The entity that is responsible for the safe and proper erection of the Materials in accordance with all applicable codes and regulations.

Specifying Professional. The licensed professional who is responsible for sealing the building Contract Documents, which indicates that he or she has performed or supervised the analysis, design and document preparation for the structure and has knowledge of the load-carrying structural system.

Structural Drawings. The graphic or pictorial portions of the Contract Documents showing the design, location and dimensions of the work. These documents generally include plans, elevations, sections, details, connections, all loads, schedules, diagrams and notes.

Placement Plans. Drawings that are prepared depicting the interpretation of the Contract Documents requirements for the Material to be supplied by the Seller. These floor and/or roof plans are approved by the **Specifying Professional**, Buyer or owner for conformance with the design requirements. The Seller uses the information contained on these drawings for final Material design. A unique

piece mark number is typically shown for the individual placement of the steel joists, Joist Girders and accessories along with sections that describe the end bearing conditions and minimum attachment required so that material is placed in the proper location in the field.

1.4 DESIGN

In the absence of ordinances or specifications to the contrary, all designs prepared by the **specifying professional** shall be in accordance with the Steel Joist Institute Standard Specifications Load Tables & Weight Tables of latest adoption.

1.5 RESPONSIBILITY FOR DESIGN AND ERECTION

When Material requirements are specified, the Seller shall assume no responsibility other than to furnish the items listed in Section 5.2 (a). When Material requirements are not specified, the Seller shall furnish the items listed in Section 5.2 (a) in accordance with Steel Joist Institute Standard Specifications Load Tables & Weight Tables of latest adoption, and this code. Pertinent design information shall be provided to the Seller as stipulated in Section 6.1. The Seller shall identify material by showing size and type. In no case shall the Seller assume any responsibility for the erection of the item furnished.

1.6 PERFORMANCE TEST FOR K-SERIES STEEL JOIST CONSTRUCTION

When performance tests on a structure are required, joists in the test panel shall have bridging and top deck applied as used. In addition to the full dead load, the test panel shall sustain for one hour a test load of 1.65 times the nominal live load. After this test load has been removed for a minimum of 30 minutes, the remaining deflection shall not exceed 20% of the deflection caused by the test load. The weight of the test panel itself shall constitute the dead load of the construction and shall include the weight of the joists, bridging, top deck, slab, ceiling materials, etc. The nominal live load shall be the live load specified and in no case shall it be more than the published joist capacity less the dead load. The cost of such tests shall be borne by the purchaser.

SECTION 2. JOISTS AND ACCESSORIES

2.1 STEEL JOISTS AND JOIST GIRDERS

Steel joists and Joist Girders shall carry the designations and meet the requirements of the Steel Joist Institute Standard Specifications Load Tables & Weight Tables of latest adoption.

K-Series joists are furnished with parallel chords only, and with minimum standard end bearing depth of 2 1/2 inches (64 mm).

LH- and **DLH-**Series joists are furnished either underslung or square ended, with top chords either parallel, pitched one way or pitched two ways. Underslung types are furnished with standard end bearing depth of 5 inches (127 mm) for



LH-Series. **DLH-Series** are furnished with standard end bearing depths of 5 inches (127 mm) for section numbers thru 17 and 7 1/2 inches (191 mm) for section numbers 18 and 19. The standard pitch is 1/8 inch in 12 inches (1:96). The nominal depth of a pitched Longspan Joist is taken at the center of the span.

Joist Girders are furnished either underslung or square ended with top chords either parallel, pitched one way or pitched two ways. Underslung types are furnished with a standard end bearing depth of 7 1/2 inches (191 mm). The standard pitch is 1/8 inch in 12 inches (1:96). The nominal depth of a pitched Joist Girder is taken at the center of the span.

Because **LH-** and **DLH-Series** joists may have exceptionally high end reactions, it is recommended that the supporting structure be designed to provide a nominal minimum unit bearing pressure of 750 pounds per square inch (5171 kilo Pascal).

2.2 JOIST LOCATION AND SPACING

The maximum joist spacing shall be in accordance with the requirements of the Steel Joist Institute Standard Specifications Load Tables & Weight Tables of latest adoption.

Where sidewalls, wall beams or tie beams are capable of supporting the floor slab or roof deck, the first adjacent joists may be placed one full space from these members. Joists are provided with camber and may have a significant difference in elevation with respect to the adjacent structure because of this camber. This difference in elevation should be given consideration when locating the first joist adjacent to a side wall, wall beam or tie beam.

Open Web Steel Joists, **K-Series**, should be placed no closer than 6 inches (152 mm) to supporting walls or members.

Where partitions occur parallel to joists, there shall be at least one joist provided under each such partition, and more than one such joist shall be provided if necessary to safely support the weight of such partition and the adjacent floor, less the live load, on a strip of floor one foot (305 mm) in width. When partitions occur perpendicular to the joists, they shall be treated as concentrated loads, and joists shall be investigated as indicated in Section 6.1.

2.3 SLOPED END BEARINGS

Where steel joists or Joist Girders are sloped, beveled ends or sloped end bearings may be provided where the slope exceeds 1/4 inch in 12 inches (1:48). When sloped end bearings are required, the seat depths shall be adjusted to maintain the standard height at the shallow end of the sloped bearing. For Open Web Steel Joists, **K-Series**, bearing ends will not be beveled for slopes of 1/4 inch or less in 12 inches (1:48).

2.4 EXTENDED ENDS

Steel joist extended ends shall be in accordance with Manufacturer's Standard and shall meet the requirements of — Appendix B.

2.5 CEILING EXTENSIONS

Ceiling extensions shall be furnished to support ceilings which are to be attached to the bottom of the joists. They are not furnished for the support of suspended ceilings. The ceiling extension shall be either an extended bottom chord element or a loose unit, whichever is standard with the manufacturer, and shall be of sufficient strength to properly support the ceiling.

TABLE 2.6-1a
K-SERIES JOISTS
MAXIMUM JOIST SPACING FOR HORIZONTAL BRIDGING

SECTION NUMBER*	**BRIDGING MATERIAL SIZE						
	Round Rod		Equal Leg Angles				
	1/2" round (13 mm) r = 0.13" (3.30 mm)	1 x 7/64 (25 mm x 3 mm) r = 0.20" (5.08 mm)	1-1/4 x 7/64 (32 mm x 3 mm) r = 0.25" (6.35 mm)	1-1/2 x 7/64 (38 mm x 3 mm) r = 0.30" (7.62 mm)	1-3/4 x 7/64 (45 mm x 3 mm) r = 0.35" (8.89 mm)	2 x 1/8 (52 mm x 3 mm) r = 0.40" (10.16 mm)	2-1/2 x 5/32 (64 mm x 4 mm) r = 0.50" (12.70 mm)
1 – 9	3'- 3" (991 mm)	5'- 0" (1524 mm)	6'- 3" (1905 mm)	7'- 6" (2286 mm)	8'- 7" (2616 mm)	10'- 0" (3048 mm)	12'- 6" (3810 mm)
10	3'- 0" (914 mm)	4'- 8" (1422 mm)	6'- 3" (1905 mm)	7'- 6" (2286 mm)	8'- 7" (2616 mm)	10'- 0" (3048 mm)	12'- 6" (3810 mm)
11–12	2'- 7" (787 mm)	4'- 0" (1219 mm)	5'- 8" (1727 mm)	7'- 6" (2286 mm)	8'- 7" (2616 mm)	10'- 0" (3048 mm)	12'- 6" (3810 mm)

* Refer to last digit(s) of Joist Designation

** Connection to Joist must resist a nominal unfactored 700 pound force (3114 N)



TABLE 2.6-1b
LH-SERIES JOISTS
MAXIMUM JOIST SPACING FOR HORIZONTAL BRIDGING
SPANS OVER 60 ft. (18.3 m) REQUIRE BOLTED DIAGONAL BRIDGING

SECTION NUMBER*	**BRIDGING ANGLE SIZE – (EQUAL LEG ANGLE)					
	1 x 7/64 (25 mm x 3 mm) r = 0.20" (5.08 mm)	1-1/4 x 7/64 (32 mm x 3 mm) r = 0.25" (6.35 mm)	1-1/2 x 7/64 (38 mm x 3 mm) r = 0.30" (7.62 mm)	1-3/4 x 7/64 (45 mm x 3 mm) r = 0.35" (8.89 mm)	2 x 1/8 (52 mm x 3 mm) r = 0.40" (10.16 mm)	2-1/2 x 5/32 (64 mm x 4 mm) r = 0.50" (12.70 mm)
02, 03, 04	4' – 7" (1397 mm)	6' – 3" (1905 mm)	7' – 6" (2286 mm)	8' – 9" (2667 mm)	10' – 0" (3048 mm)	12' – 4" (3759 mm)
05 – 06	4' – 1" (1245 mm)	5' – 9" (1753 mm)	7' – 6" (2286 mm)	8' – 9" (2667 mm)	10' – 0" (3048 mm)	12' – 4" (3759 mm)
07 – 08	3' – 9" (1143 mm)	5' – 1" (1549 mm)	6' – 8" (2032 mm)	8' – 6" (2590 mm)	10' – 0" (3048 mm)	12' – 4" (3759 mm)
09 – 10		4' – 6" (1372 mm)	6' – 0" (1829 mm)	7' – 8" (2337 mm)	10' – 0" (3048 mm)	12' – 4" (3759 mm)
11 – 12		4' – 1" (1245 mm)	5' – 5" (1651 mm)	6' – 10" (2083 mm)	8' – 11" (2718 mm)	12' – 4" (3759 mm)
13 – 14		3' – 9" (1143 mm)	4' – 11" (1499 mm)	6' – 3" (1905 mm)	8' – 2" (2489 mm)	12' – 4" (3759 mm)
15 – 16			4' – 3" (1295 mm)	5' – 5" (1651 mm)	7' – 1" (2159 mm)	11' – 0" (3353 mm)
17			4' – 0" (1219 mm)	5' – 1" (1549 mm)	6' – 8" (2032 mm)	10' – 5" (3175 mm)

* Refer to last two digits of Joist Designation

** Connection to Joist must resist force listed in Table 104.5-1

2.6 BRIDGING AND BRIDGING ANCHORS

- (a) Bridging standard with the manufacturer and complying with the Steel Joist Institute Standard Specifications Load Tables & Weight Tables of latest adoption shall be used for bridging all joists furnished by the manufacturer. Positive anchorage shall be provided at the ends of each bridging row at both top and bottom chords.
- (b) For **K-** and **LH-Series** Joists horizontal bridging is recommended for spans up to and including 60 feet (18.3 m) except where the Steel Joist Institute Standard Specifications Load Tables & Weight Tables require bolted diagonal bridging for erection stability.

LH- and **DLH-Series** Joists exceeding 60 feet (18.3 m) in length shall have bolted diagonal bridging for all rows.

Refer to Section 6 in the **K-Series** Specifications and Section 105 in the **LH-** and **DLH-Series** Specifications for erection stability requirements.

Refer to Appendix E for OSHA steel joist erection stability requirements.

Horizontal bridging shall consist of continuous horizontal steel members. The l/r ratio for horizontal bridging shall not exceed 300. The material sizes shown in Tables 2.6-1a and 2.6-1b meet the criteria.

- (c) Diagonal cross bridging consisting of angles or other shapes connected to the top and bottom chords, of **K-**, **LH-** and **DLH-Series** Joists shall be used when required by the applicable Steel Joist Institute Standard Specifications Load Tables & Weight Tables of latest adoption.

Diagonal bridging, when used, shall have an l/r ratio not exceeding 200.

When the bridging members are connected at their point of intersection, the material sizes listed in Table 2.6-2 will meet the above specification.



CODE OF STANDARD PRACTICE FOR STEEL JOISTS AND JOIST GIRDERS

- (d) When bolted diagonal erection bridging is required, the following shall apply:
1. The bridging shall be indicated on the joist placement plan.
 2. The joist placement plan shall be the exclusive indicator for the proper placement of this bridging.
 3. Shop installed bridging clips, or functional equivalents, shall be provided where the bridging bolts to the steel joist.

4. When two pieces of bridging are attached to the steel joist by a common bolt, the nut that secures the first piece of bridging shall not be removed from the bolt for the attachment of the second piece.
5. Bridging attachments shall not protrude above the top chord of the steel joists.

TABLE 2.6-2
K, LH AND DLH SERIES JOISTS
MAXIMUM JOIST SPACING FOR DIAGONAL BRIDGING

JOIST DEPTH	**BRIDGING ANGLE SIZE – (EQUAL LEG ANGLE)				
	1 x 7/64 (25 mm x 3 mm) r = 0.20" (5.08 mm)	1-1/4 x 7/64 (32 mm x 3 mm) r = 0.25" (6.35 mm)	1-1/2 x 7/64 (38 mm x 3 mm) r = 0.30" (7.62 mm)	1-3/4 x 7/64 (45 mm x 3 mm) r = 0.35" (8.89 mm)	2 x 1/8 (50 mm x 3 mm) r = 0.40" (10.16 mm)
12" (305 mm)	6' – 6" (1981 mm)	8' – 3" (2514 mm)	9' – 11" (3022 mm)	11' – 7" (3530 mm)	
14" (356 mm)	6' – 6" (1981 mm)	8' – 3" (2514 mm)	9' – 11" (3022 mm)	11' – 7" (3530 mm)	
16" (406 mm)	6' – 6" (1981 mm)	8' – 2" (2489 mm)	9' – 10" (2997 mm)	11' – 6" (3505 mm)	
18" (457 mm)	6' – 6" (1981 mm)	8' – 2" (2489 mm)	9' – 10" (2997 mm)	11' – 6" (3505 mm)	
20" (508 mm)	6' – 5" (1955 mm)	8' – 2" (2489 mm)	9' – 10" (2997 mm)	11' – 6" (3505 mm)	
22" (559 mm)	6' – 4" (1930 mm)	8' – 1" (2463 mm)	9' – 10" (2997 mm)	11' – 6" (3505 mm)	
24" (610 mm)	6' – 4" (1930 mm)	8' – 1" (2463 mm)	9' – 9" (2971 mm)	11' – 5" (3479 mm)	
26" (660 mm)	6' – 3" (1905 mm)	8' – 0" (2438 mm)	9' – 9" (2971 mm)	11' – 5" (3479 mm)	
28" (711 mm)	6' – 2" (1879 mm)	8' – 0" (2438 mm)	9' – 8" (2946 mm)	11' – 5" (3479 mm)	
30" (762 mm)	6' – 2" (1879 mm)	7' – 11" (2413 mm)	9' – 8" (2946 mm)	11' – 4" (3454 mm)	
32" (813 mm)	6' – 1" (1854 mm)	7' – 10" (2387 mm)	9' – 7" (2921 mm)	11' – 4" (3454 mm)	13' – 0" (3962 mm)
36" (914 mm)		7' – 9" (2362 mm)	9' – 6" (2895 mm)	11' – 3" (3429 mm)	12' – 11" (3973 mm)
40" (1016 mm)		7' – 7" (2311 mm)	9' – 5" (2870 mm)	11' – 2" (3403 mm)	12' – 10" (3911 mm)
44" (1118 mm)		7' – 5" (2260 mm)	9' – 3" (2819 mm)	11' – 0" (3352 mm)	12' – 9" (3886 mm)
48" (1219 mm)		7' – 3" (2209 mm)	9' – 2" (2794 mm)	10' – 11" (3327 mm)	12' – 8" (3860 mm)
52" (1321 mm)			9' – 0" (2743 mm)	10' – 9" (3276 mm)	12' – 7" (3835 mm)
56" (1422 mm)			8' – 10" (2692 mm)	10' – 8" (3251 mm)	12' – 5" (3784 mm)
60" (1524 mm)			8' – 7" (2616 mm)	10' – 6" (3200 mm)	12' – 4" (3759 mm)
64" (1626 mm)			8' – 5" (2565 mm)	10' – 4" (3149 mm)	12' – 2" (3708 mm)
68" (1727 mm)			8' – 2" (2489 mm)	10' – 2" (3098 mm)	12' – 0" (3657 mm)
72" (1829 mm)			8' – 0" (2438 mm)	10' – 0" (3048 mm)	11' – 10" (3606 mm)

MINIMUM A307 BOLT REQUIRED FOR CONNECTION		
SERIES	*SECTION NUMBER	BOLT DIAMETER
K	ALL	3/8" (10 mm)
LH, DLH	2 - 12	3/8" (10 mm)
LH, DLH	13 - 17	1/2" (13 mm)
DLH	18 and 19	5/8" (16 mm)

*Refer to last digit(s) of Joist Designation



2.7 HEADERS

Headers for Open Web Steel Joists, **K-Series** as outlined and defined in Section 5.2 (a) shall be furnished by the Seller. Such headers shall be any type standard with the manufacturer. Conditions involving headers shall be investigated and, if necessary, provisions made to provide a safe condition. Headers are not provided for Longspan Steel Joists, **LH-Series**, and Deep Longspan Steel Joists, **DLH-Series**.

2.8 BOTTOM CHORD LATERAL BRACING FOR JOIST GIRDERS

Bottom chord lateral bracing may be furnished to prevent lateral movement of the bottom chord of the Joist Girder and to prevent the ratio of chord length to chord radius of gyration from exceeding that specified in the Steel Joist Institute Standard Specifications Load Tables & Weight Tables of latest adoption. The lateral bracing shall be that which is standard with the manufacturer, and shall be sufficient to properly brace the bottom chord of the Joist Girder.

SECTION 3. MATERIALS

3.1 STEEL

The steel used in the manufacture of joists and Joist Girders shall comply with the Steel Joist Institute Standard Specifications Load Tables & Weight Tables of latest adoption.

3.2 PAINT

- (a) Standard Shop Paint - The shop coat of paint, when specified, shall comply with the Steel Joist Institute Standard Specifications Load Tables & Weight Tables of latest adoption.
- (b) Disclaimer - The typical shop applied paint that is used to coat steel joists and Joist Girders is a dip applied, air dried paint. The paint is intended to be an impermanent and provisional coating which will protect the steel for only a short period of exposure in ordinary atmospheric conditions.

Since most steel joists and Joist Girders are painted using a standard dip coating, the coating may not be uniform and may include drips, runs, and sags. Compatibility of any coating including fire protective coatings applied over a standard shop paint shall be the responsibility of the specifier and/or painting contractor.

The shop applied paint may require field touch-up/repair as a result of, but not limited to, the following:

1. Abrasions from: Bundling, banding, loading and unloading, chains, dunnage during shipping, cables and chains during erection, bridging, installation, and other handling at the jobsite.

NOTE: Rusting should be expected at any abrasion.

2. Dirt.
3. Diesel smoke.
4. Road salt.
5. Weather conditions during storage.

The joist manufacturer shall not be responsible for the condition of the paint if it is not properly protected after delivery.

SECTION 4. INSPECTION

Inspections shall be made in accordance with the Steel Joist Institute Standard Specifications Load Tables & Weight Tables Section 5.12 for **K-Series**, Section 104.13 for **LH-** and **DLH-Series**, and Section 1004.10 for Joist Girders.

SECTION 5. ESTIMATING

5.1 PLANS FOR BIDDING

Plans to serve as the basis for bids shall show the character of the work with sufficient clarity to permit making an accurate estimate and shall show the following:

- Designation and location of Materials (See Section 5.2 [a]), including any special design or configuration requirements.

- Locations and elevations of all steel and concrete supporting members and bearing walls.

- Location and length of joist extended ends.

- Location and size of all openings in floors and roofs.

- Location of all partitions.

- Loads and their locations as defined in Section 6.1.

- Construction and thickness of floor slabs, roof deck, ceilings and partitions.

- Joists or Joist Girders requiring extended bottom chords.

- Paint, if other than manufacturer's standard.

5.2 SCOPE OF ESTIMATE

- (a) Unless otherwise specified, the following items shall be included in the estimate, and requirements shall be determined as outlined in Section 6.1.

- Steel Joists.

- Joist Girders.

- Joist Substitutes.

- Joist Extended Ends.

- Ceiling Extensions.

- Extended bottom chord used as strut.

- Bridging and bridging anchors.

- Joist Girder bottom chord bracing.

- Headers which are defined as members supported by and carrying Open Web Steel Joists, **K-Series**.

- One shop coat of paint, when specified, shall be in accordance with Section 3.2.

- (b) The following items shall not be included in the estimate but may be quoted and identified by the joist manufacturer as separate items:

- Headers for Longspan Steel Joists, **LH-Series**.



Headers for Deep Longspan Steel Joists, **DLH-Series**.
 Reinforcement in slabs over joists.
 Centering material, decking, and attachments.
 Miscellaneous framing between joists for openings at ducts, dumbwaiters, ventilators, skylights, etc.
 Loose individual or continuous bearing plates and bolts or anchors for such plates.
 Erection bolts for joist and Joist Girder end anchorage.
 Horizontal bracing in the plane of the top and bottom chords from joist to joist or joist to structural framing and walls.
 Wood nailers.
 Moment plates.
 Special joist configuration or bridging layouts for ductwork or sprinkler systems.
 Shear Studs.

SECTION 6.
PLANS AND SPECIFICATIONS

6.1 PLANS FURNISHED BY BUYER

The Buyer shall furnish the Seller plans and specifications as prepared by the **specifying professional** showing all Material requirements and steel joist and/or steel Joist Girder designations, the layout of walls, columns, beams, girders and other supports, as well as floor and roof openings and partitions correctly dimensioned. The live loads to be used, the wind uplift if any, the weights of partitions and the location and amount of any special loads, such as mono-rails, fans, blowers, tanks, etc., shall be indicated. The elevation of finished floors, roofs, and bearings shall be shown with due consideration taken for the effects of dead load deflections.

(a) Loads -

The Steel Joist Institute does not presume to establish the loading requirements for which structures are designed.

The Steel Joist Institute Load Tables are based on uniform loading conditions and are valid for use in selecting joist sizes for gravity loads that can be expressed in terms of "pounds per linear foot" (kiloNewtons per Meter) of joist. The Steel Joist Institute Joist Girder Weight Tables are based on uniformly spaced panel point loading conditions and are valid for use in selecting Joist Girder sizes for gravity conditions that can be expressed in kips (kiloNewtons) per panel point on the Joist Girder.

The **specifying professional** shall provide the nominal loads and load combinations as stipulated by the applicable code under which the structure is designed and shall provide the design basis (ASD or LRFD).

The **specifying professional** shall calculate and provide the magnitude and location of ALL JOIST and

JOIST GIRDER LOADS. This includes all special loads (drift loads, mechanical units, net uplift, axial loads, moments, structural bracing loads, or other applied loads) which are to be incorporated into the joist or Joist Girder design. For Joist Girders, reactions from supported members shall be clearly denoted as point loads on the Joist Girder. When necessary to clearly convey the information, a Load Diagram or Load Schedule shall be provided.

The **specifying professional** shall give due consideration to the following loads and load effects:

1. Ponded rain water.
2. Accumulation of snow in the vicinity of obstructions such as penthouses, signs, parapets, adjacent buildings, etc.
3. Wind.
4. Type and magnitude of end moments and/or axial forces at the joist and Joist Girder end supports shall be shown on the structural drawings. For moment resisting joists or Joist Girders framing near the end of a column, due consideration shall be given to extend the column length to allow a plate type connection between the top of the joist or Joist Girder top chord and the column.

Avoid resolving joist or Joist Girder end moments and axial forces through the bearing seat connection.

A note shall be provided on the structural drawings stating that all moment resisting joists shall have all dead loads applied to the joist before the bottom chord struts are welded to the supporting connection whenever the moments provided do not include dead load.

The top and bottom chord moment connection details shall be designed by the **specifying professional**. The joist designer shall furnish the **specifying professional** with the joist detail information if requested.

The nominal loads, as determined by the **specifying professional**, shall not be less than that specified in the applicable building codes.

Where concentrated loads occur, the magnitude and location of these concentrated loads shall be shown on the **structural drawings** when, in the opinion of the **specifying professional**, they may require consideration by the joist manufacturer.

The **specifying professional** shall use one of the following options that allows the:

- Estimator to price the joists.
- Joist manufacturer to design the joists properly.
- Owner to obtain the most economical joists.

Option 1: Select a Standard Steel Joist Institute joist for the uniform design loading and provide the load and location of any additional loads on the structural plan with a note "Joist manufacturer shall design joists for additional loads as shown". This option works well for a few added loads per joist with known locations.



Option 2: Select a KCS joist using moment and end reaction. This option works well for concentrated loads for which exact locations are not known or for multiple loading. See examples and limitations on the pages accompanying the KCS Joist Load Tables.

- Determine the maximum moment
- Determine the maximum end reaction (shear)
- Select the required KCS joist that provides the required moment and end reaction (shear).

Option 3: Specify a SPECIAL joist with load diagrams. This option is preferred when the joist includes loading that cannot clearly be denoted on the structural drawings.

- Provide a load diagram to clearly define ALL loads
- Place the designation (i.e. 18K SP or 18LH SP) under the load diagram with the following note: "Joist manufacturer to design joist to support loads as shown above".

CAUTION: The **specifying professional** shall compare the equivalent uniform loads derived from the maximum moment and shear to the uniform loads tabulated in the **K-Series** Load Table. An equivalent unfactored uniform load in excess of 550 plf (8020 N/m) or a maximum unfactored end reaction exceeding 9200 lbs (40.9 kN) indicates that the **specifying professional** shall consider using additional joists to reduce the loading or use an **LH-Series** Joist and make provisions for 5 inch (127 mm) deep bearing seats.

SPECIAL LOADING : Please note the load combinations shown are for referenced examples only and it is not to be presumed that the joist designer is responsible for the applicable building code load combinations. If the loading criteria are too complex to adequately communicate in a simple load diagram, then the **specifying professional** shall provide a load schedule showing the specified design loads, load categories, and required load combinations with applicable load factors.

ASD EXAMPLE:

U.S. CUSTOMARY UNITS AND (METRIC UNITS)

Load diagram per ASCE 7 2.4.1(3) **D + S**

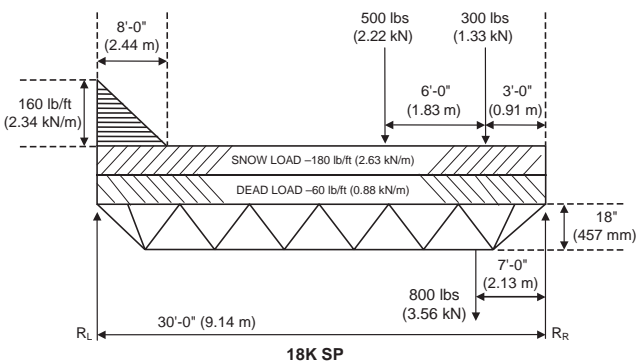

Joist manufacturer to design joist to support loads as shown above.

LRFD EXAMPLE:

U.S. CUSTOMARY UNITS AND (METRIC UNITS)

Factored Load diagram per ASCE 7 2.3.2(3) **1.2D + 1.6S**

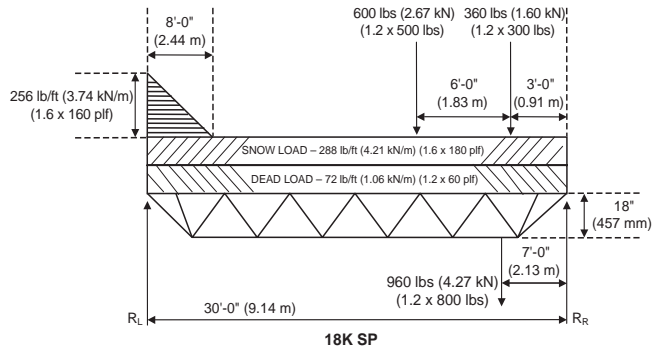

Joist manufacturer to design joist to support factored loads as shown.

(b) Connections -

Minimum End Anchorage for simple span gravity loading shall be in accordance with Steel Joist Institute Standard Specifications Load Tables & Weight Tables Section 5.6 for **K-Series**, Section 104.4 for **LH-** and **DLH-Series**, and Section 1004.6 for Joist Girders. The **specifying professional** is responsible for the design of the joist and Joist Girder connection when it is subject to any loads other than simple span gravity loading including uplift and lateral loads. The **specifying professional** is also responsible for bridging termination connections. The contract documents must clearly illustrate these connections.

(c) Special Considerations

The **specifying professional** shall indicate on the construction documents special considerations including:

- Profiles for non-standard joist and Joist Girder configurations (Standard joist and Joist Girder configurations are as indicated in the Steel Joist Institute Standard Specifications Load Tables & Weight Tables of latest adoption).
- Oversized or other non-standard web openings
- Extended ends
- Deflection criteria for live and total loads for non-SJI standard joists
- Non-SJI standard bridging

6.2 PLANS FURNISHED BY SELLER

The Seller shall furnish the Buyer with steel joist placement plans to show the Material as specified on the construction documents and are to be utilized for field installation in accordance with specific project requirements as stated in Section 6.1. Steel placement plans shall include, at a minimum, the following:

- Listing of all applicable loads as stated in Section 6.1 and used in the design of the steel joists and Joist Girders as specified in the construction documents.



2. Profiles for non-standard joist and Joist Girder configurations (Standard joist and Joist Girder configurations are as indicated in the Steel Joist Institute Standard Specifications Load Tables & Weight Tables of latest adoption).
3. Connection requirements for:
 - a) Joists supports
 - b) Joist Girder supports
 - c) Field splices
 - d) Bridging attachments
4. Deflection criteria for live load and total loads for non-SJI standard joists.
5. Size, location, and connections for all bridging
6. Joists headers

All Material shall be identified with its mark which also appears on the bill of material. The shop paint shall be as noted on the joist placement plans. **Steel joist placement plans do not require the seal and signature of the joist manufacturer's registered design professional.**

6.3 DISCREPANCIES

The specifying professional's bid plans and specifications will be assumed to be correct in the absence of written notice from the Buyer to the contrary. When plans are furnished by the Buyer which do not agree with the Architect's bid plans, such detailed plans shall be considered as a written notice of change of plans. However, it shall be the Buyer's responsibility to advise the Seller of those changes which affect the joists or Joist Girders.

6.4 APPROVAL

When joist placement plans are furnished by the Seller, prints thereof are submitted to the Buyer and owner for examination and approval. The Seller allows a maximum of fourteen (14) calendar days in their schedule for the return of placement plans noted with the owner's and customer's approval, or approval subject to corrections as noted. The Seller makes the corrections, furnishes corrected prints for field use to the owner/customer and is released by the owner/customer to start joist manufacture.

Approval by the owner/customer of the placement plans, sections, notes and joist schedule prepared by the Seller indicates that the Seller has correctly interpreted the contract requirements, and is released by the owner/customer to start joist manufacture. This approval constitutes the owner's/customer's acceptance of all responsibility for the design adequacy of any detail configuration of joist support conditions shown by the Seller as part of the preparation of these placement plans.

Approval does not relieve the Seller of the responsibility for accuracy of detail dimensions on the plans, nor the general fit-up of joists to be placed in the field.

6.5 CHANGES

When any changes in plans are made by the buyer (or the buyers representative) either prior to or after approval of detailed plans, or when any Material is required and was not

shown on the plans used as the basis of the bid, the cost of such changes and/or extra Material shall be paid by the Buyer at a price to be agreed upon between Buyer and Seller.

6.6 CALCULATIONS

The seller shall design the steel joists and/or steel Joist Girders in accordance with the current Steel Joist Institute Standard Specifications Load Tables & Weight Tables to support the load requirements of Section 6.1. The **specifying professional** may require submission of the steel joist and Joist Girder calculations as prepared by a registered design professional responsible for the product design. If requested by the **specifying professional**, the steel joist manufacturer shall submit design calculations with a cover letter bearing the seal and signature of the joist manufacturer's registered design professional. In addition to standard calculations under this seal and signature, submittal of the following shall be included:

1. Non-SJI standard bridging details (e.g. for cantilevered conditions, net uplift, etc.)
2. Connection details for:
 - a) Non-SJI standard connections (e.g. flush framed or framed connections)
 - b) Field splices
 - c) Joist headers

SECTION 7.*

HANDLING AND ERECTION

The current OSHA SAFETY STANDARDS FOR STEEL ERECTION, 29 CFR PART 1926, SUBPART R- STEEL ERECTION, refers to certain joists at or near columns to be designed with sufficient strength to allow one employee to release the hoisting cable without the need for erection bridging. **This STANDARD shall not be interpreted that any joist at or near a column line is safe to support an employee without bridging installed.** Many limitations exist that prevent these joists from being designed to safely allow an employee on an un-bridged joist. Because of these limitations these joists must be erected by incorporating erection methods ensuring joist stability and either:

- 1) Installing bridging or otherwise stabilizing the joist prior to releasing the hoisting cable, or
- 2) Releasing the hoisting cable without having a worker on the joist.

A steel joist or Joist Girder shall not be placed on any support structure unless such structure is stabilized. When steel joists or Joist Girders are landed on a structure, they shall be secured to prevent unintentional displacement prior to installation.

A bridging terminus point shall be established before joist bridging is installed.

Steel joist and Joist Girders shall not be used as anchorage points for a fall arrest system unless written directions to do so is obtained from a "qualified person"⁽¹⁾.



No modification that affects the strength of a steel joist or Joist Girder shall be made without the written approval of the project engineer of record.

The Buyer and/or Erector shall check all materials on arrival at job site and promptly report to Seller any discrepancies and/or damages. The Buyer and/or Erector shall comply with the requirements of the Steel Joist Institute Standard Specifications Load Tables & Weight Tables of latest adoption in the handling and erection of Material.

The Seller shall not be responsible for the condition of paint finish on Material if it is not properly protected after delivery.

The Seller shall not be responsible for improper fit of Material due to inaccurate construction work.

* For thorough coverage of this topic, refer to SJI Technical Digest #9, "Handling and Erection of Steel Joists and Joist Girders".

(1) See Appendix E for OSHA definition of a qualified person.

SECTION 8. **BUSINESS RELATIONS**

8.1 PRESENTATION OF PROPOSALS

All proposals for furnishing Material shall be made on a Sales Contract Form. After acceptance by the Buyer, these proposals must be approved or executed by a qualified official of the Seller. Upon such approval the proposal becomes a contract.

8.2 ACCEPTANCE OF PROPOSALS

All proposals are intended for prompt acceptance and are subject to change without notice.

8.3 BILLING

Contracts on a lump sum basis are to be billed proportionately as shipments are made.

8.4 PAYMENT

Payments shall be made in full on each invoice without retention.

8.5 ARBITRATION

All business controversies which cannot be settled by direct negotiations between Buyer and Seller shall be submitted to arbitration. Both parties shall sign a submission to arbitration and if possible agree upon an arbitrator. If they are unable to agree, each shall appoint an arbitrator and these two shall appoint a third arbitrator. The expenses of the arbitration shall be divided equally between the parties, unless otherwise provided for in the agreements to submit to arbitration. The arbitrators shall pass final judgment upon all questions, both of law and fact, and their findings shall be conclusive.

